

**Parametric modelling method based on Knowledge Based Engineering:  
The LNG bunkering vessel case**

Charisi, N.D.; Hopman, J.J.; Kana, A.A.; Papapanagiotou, Nikos; Muller , Thijs

**Publication date**

2020

**Document Version**

Final published version

**Published in**

Proceedings of the 12th Symposium on High-Performance Marine Vehicles, HIPER '20

**Citation (APA)**

Charisi, N. D., Hopman, J. J., Kana, A. A., Papapanagiotou, N., & Muller , T. (2020). Parametric modelling method based on Knowledge Based Engineering: The LNG bunkering vessel case. In V. Bertram (Ed.), *Proceedings of the 12th Symposium on High-Performance Marine Vehicles, HIPER '20* (pp. 102-117). Technische Universität Hamburg-Harburg.

**Important note**

To cite this publication, please use the final published version (if applicable).  
Please check the document version above.

**Copyright**

Other than for strictly personal use, it is not permitted to download, forward or distribute the text or part of it, without the consent of the author(s) and/or copyright holder(s), unless the work is under an open content license such as Creative Commons.

**Takedown policy**

Please contact us and provide details if you believe this document breaches copyrights.  
We will remove access to the work immediately and investigate your claim.

**12<sup>th</sup> Symposium on  
High-Performance Marine Vehicles**

# **HIPER'20**

**Cortona, 12-14 October 2020**

Edited by Volker Bertram

# Parametric Modelling Method based on Knowledge Based Engineering: The LNG Bunkering Vessel Case

**Nikoleta Dimitra Charisi**, TU Delft, Delft/ Netherlands, [N.D.Charisi@tudelft.nl](mailto:N.D.Charisi@tudelft.nl)

**Hans Hopman**, TU Delft, Delft/Netherlands, [J.J.Hopman@tudelft.nl](mailto:J.J.Hopman@tudelft.nl)

**Austin Kana**, TU Delft, Delft/Netherlands, [A.A.Kana@tudelft.nl](mailto:A.A.Kana@tudelft.nl)

**Nikos Papapanagiotou**, C-Job Naval Architects, Hoofddorp/Netherlands, [n.papapanagiotou@c-job.com](mailto:n.papapanagiotou@c-job.com)

**Thijs Muller**, C-Job Naval Architects, Hoofddorp/Netherlands, [t.muller@c-job.com](mailto:t.muller@c-job.com)

## Abstract

*This paper proposes a parametric modelling method based on Knowledge Based Engineering (KBE) for an LNG bunkering vessel (LNGBV). Parametric models aim to define the geometry and main systems configuration of the vessel starting from the principle that the vessel should be able to perform its mission successfully. The adoption of KBE in combination with parametric modelling is expected to improve the current practice by automating the generation of the parametric models based on the design requirements. The results showed that different design alternatives can be rapidly generated which in turn gives the possibility to the designer to perform a wide exploration of the preliminary design space.*

## 1. Introduction

Nowadays, advanced design solutions need to be developed with ever shorter lead-times due to the enhanced competitiveness of the shipping industry resulting from digitalization, <https://www.shipfinance.dk/media/1817/shipping-market-review-may-2018.pdf>, and the stringent regulatory framework (Global Sulphur Cap 2020, IMO's strategy for reducing greenhouse gas emissions). To support this, the designer must perform a broad exploration of the preliminary design space to develop improved design solutions. Parametric models form a core element of the preliminary design process designed to facilitate this exploration. Specifically, parametric models are connected with design optimization routines and analysis performed by dedicated software tools. By developing different configurations associated with a design problem and predicting their performance, the designer is able to make efficient trade-offs, *Duchateau (2016)*. Parametric models provide a visualization of the designed vessel, which helps the designer understand the design problem, create relevant design solutions, and evaluate potential solutions that have been developed, *Dahl et al. (2001)*.

The European ship design industry puts effort into developing large and expansive knowledge-bases to support design, engineering and manufacturing, *Bruinessen et al. (2013)*. The stored knowledge regarding preliminary ship design contains previous design cases and existing vessel data, generalised design cases, templates, syntactic knowledge, rules and facts, and problem solving methods, strategy and tactics, *Erikstad (2007)*. The common practice for parametric modelling is that parametric models are developed via the combination of different geometric primitives (points, lines, surfaces, etc). This practice requires a lot of manual effort and repetitive non-creative engineering work. However, the efficient exploitation of design knowledge gives the potential to automate parametric modelling. Consecutively, the developed parametric models can be used as an input to the most suitable software packages, including CAD packages and analysis tools.

Knowledge Based Engineering (KBE) is a method used to identify, record, and re-use relevant engineering knowledge in product design, *van Tooren et al. (2003)*. The improvement resulting from its adoption is that the proposed parametric modelling method is based on the development of knowledge building blocks, called High Level Primitives (HLPs), rather than geometric primitives. The HLPs are instantiated according to the design requirements and decisions and combined to form a design solution. In order to form another design solution, the HLPs can be re-instantiated according to the designer's decisions.

As a case study, the proposed parametric modelling method is applied to the preliminary design of an LNG bunkering vessel (LNGBV). From a design point of view, the LNGBV design case is interesting due to the fact that there are only a few LNGBVs built at the moment and as a consequence, the design can not be reliably based on reference data.

## 2. Parametric Modelling in early design stages

Parametric models have been widely researched and applied in many different fields of product design such as aerospace, *Wei (2016)*, automotive, *Wan et al. (2005)*, and architecture, *Hernandez (2006)*. By employing the parametric design procedure, the design and optimization of a mechanical engineering system can be automated by the elaboration of sets of design parameters defined by the designer or an optimisation algorithm, *Papanikolaou (2019)*. Regarding early-stage ship design, naval architects use parametric modelling to establish a consistent parametric description of the vessel in terms of its dimensions and other descriptive parameters, *Parsons (2004)*. The parametric models must be flexible and generic to apply to many design alternatives, *Kanellopoulou et al. (2019)*. Regarding the design of large integrated systems such as a ship, the development of parametric models is a complicated task in order to ensure their integrity, accuracy, robustness and functionality, *Papanikolaou (2019)*.

There are a few commercially available software tools exploiting the capabilities of parametric modelling. The different approaches vary from commercially available ship parametric modelling tools such as FRIENDSHIP-Modeler via integration of parametric capabilities to a well-established ship design system such as NAPA to more restricted methods like the parametric definition of shape deformation functions (GMS/Facet), *Maisonneuve et al. (2003)*. Regarding the case study presented in this paper, NAPA software will be used for the development of the parametric models.

Several studies are dedicated to the parameterization of the hull. The generation of the parametric model of the hull is used for hydrodynamic optimization. *Biliotti et al. (2011)* developed a framework for the automatic optimization of the fore hull forms of a fast frigate. *Brizzolara et al. (2015)* researched global hull optimization by using CFD. *Timur (2015)* developed a parametric modelling tool in Java programming for rapid hull geometry generation. *Sanchez (2016)* presented a method for parameterization regarding different merchant vessel types by using FRIENDSHIP framework.

Several studies are examining parametric modelling from the holistic design approach perspective. The holistic design approach is explained in *Papanikolaou (2014)*. Parametric models for different vessel types are created in the studies *Papanikolaou (2010)*, *Papandreou and Papanikolaou (2015)*, *Priftis et al. (2016)*, *Marzi et al. (2018)*, *Kanellopoulou (2019)*. The developed models were further optimized by optimization algorithms. The software used for the parameterization is either NAPA or CAESSES. In the context of SHOPERA project *Kanellopoulou (2019)*, a series of parametric models have been generated for various types and sizes of ships, such as RoPax ships, cruise ships, tankers, bulk carriers, container ships and general cargo carriers using Computer-Aided Ship Design (CASD) software tools. Furthermore, the H2020 European Research project – HOLISHIP – Holistic Optimisation of Ship Design and Operation for Life Cycle (2016-2020), *Papanikolaou et al. (2020)*, aims to achieve improved vessel concepts for the 21<sup>st</sup> century.

Parametric models have also been developed based on the Design Building Block (DBB) approach. More specifically, in the context of Low Carbon Shipping and Shipping in Changing Climates, the Whole Ship Model (WSM) was developed. The model combines a parametric model with the operational profile and a range of performance-enhancing or emissions-reducing technologies, *Calleya et al. (2016)*.

Therefore, engineers are effectively using parametric modelling in a wide variety of applications in the ship design field. Depending on the way of setting up the parametric models, they can reflect different design methodologies and adapt to various design problems. The present paper examines the application of a parametric modelling method based on KBE for preliminary ship design. The

proposed approach differentiates itself from the traditionally established method based on CAD. The difference between KBE and CAD is highlighted in *La Rocca (2012)*.

### 3. Knowledge Based Engineering (KBE)

KBE is defined as a technology that allows capturing product and process multidisciplinary knowledge employing integrated software applications that can automate the repetitive design activities, and as a result, reduce engineering time and cost, *La Rocca and van Tooren (2010)*. The core of KBE is the identification, record, and re-use of engineering knowledge by combining Artificial Intelligence (AI) techniques, IT tools and Object-Oriented methodologies, *van Tooren et al. (2003)*.

KBE which was developed as part of Knowledge Based Systems (KBSs) in the field of Artificial Intelligence (AI), dates back to 1970s, *Sobieski et al. (2015)*. Regarding engineering applications, KBSs faced two major limitations, namely the inability for geometry manipulation and data processing, *La Rocca (2012)*. The technological advancements in the field of CAD and CAE systems addressed these limitations, and the concept of KBE began to be widely applied in product design, *La Rocca (2012)*. Nowadays, KBE tools are being used by many companies operating in the automotive and aerospace sector. In the aerospace industry, Airbus, *Cooper et al. (2001)*, Fokker Elmo, *van den Berg (2013)*, are some examples, to mention but a few.

The KBE product model represents the core of every KBE application, and it consists of a structured and dynamic network of classes where both product and process knowledge, both geometry-related and non-geometry related are modelled using a broad typology of rules *La Rocca (2012)*. The KBE product model consists of High Level Primitives (HLPs), which are objects containing product and engineering knowledge that can be used and re-used in different configurations *La Rocca and van Tooren (2006)*. The HLPs can be seen as functional blocks that allow the designer to define a product as a result of a structured set of HLPs. These functional blocks are a set of rules using parameters to initiate objects that represent the product under consideration or to apply an engineering process to the initiated object *Schut and van Tooren (2007)*. A clear example of different aircraft configurations resulted from the combination of the re-instantiation of the same five HLPs is shown in Fig.1.

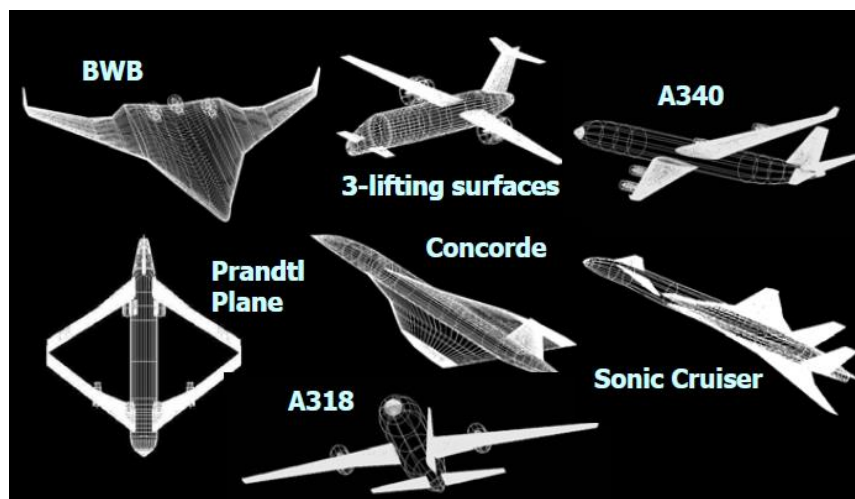

Fig.1: Design variations for the aircraft's preliminary design *van Tooren et. al (2003)*

Knowledge is the core element of every KBE model. Knowledge can be defined as relations between facts and becomes central when it comes to reasoning processes *Rehn (2018)*. Design supporting knowledge includes the methods and data (presented in forms of handbooks), software for recording analysis (CAD and CFD software) and humans experts *van Tooren et al. (2003)*. The challenges of the method can be identified in the identification of the knowledge in an organization, its capture, and formalization in reusable rules and the way of embedding them in the KBE system.

KBE has been extensively researched and applied in preliminary aircraft design. More specifically, the Design Engineering Engine (DEE), which is an integrated design support tool, was developed for the aircraft's conceptual design at TU Delft *van Tooren et al. (2003)*. The DEE consists of an initiator, an optimization algorithm, and the relevant analysis tools connected with aerodynamics, structures, and manufacturing. Further information can be found in *Schut and van Tooren (2008)*.

Ship design is a suitable field for the application of KBE due to its associated complexity. However, the applications of KBE in the maritime field are limited due to the high level of customization. The study of *Wu and Shaw (2011)* suggested a basic (preliminary) ship design knowledge-model for information storage and retrieval using KBE and developed a semantic inquiry function that allows users to use the retrieved information immediately. The acquired knowledge was collected from experienced engineers or information from journals and theses. In addition, KBE methodology has been also used for ship hull structural member design *Yang et al. (2012)*. The concept of exploiting gained knowledge in ship design forms a part of current scientific research. The data-driven design developed by *Gaspar (2018)*, make use of data regarding both the product (ship) and the process (design) to extract information and knowledge. Also, *Arendt and van Uden (2011)* developed a decision-making module for enhancing automation in ship design. The selected method for the creation of the database was the Analytic Hierarchy Process (AHP), which was applied in the selection of the temperature sensors in a fuel transport system.

Following the KBE principles applied in aircraft's preliminary design, the proposed parametric modelling method was developed. It is expected that the method will improve parametric modelling by the automation of the models' generation.

#### **4. Proposed Method**

The method consists of eight steps, and its flowchart is depicted in Fig.2. The method consists of the following steps:

1. Identification of the design requirements  
The first step of the research procedure is to determine the design requirements. These are dependent on the vessel type, its associated functions, and the specific design problem. In general, for commercial vessels, the design requirements focus on deadweight, speed, and building cost of the vessel. The design requirements correspond to the input variables, which lead to the tuning of the parametric model.
2. Main drivers analysis  
The main drivers analysis is conducted to identify the way that the vessel should be parameterized. The main drivers analysis mainly depends on the vessel type and its associated functions. In this step, the vessel's functions are mapped to the required systems.
3. Determine the HLPs  
The third step consists of the determination of the HLPs (the 'building blocks') of the examined vessel. The principles of KBE will be used for the definition and modelling of the HLPs. The HLPs form the toolkit from which different parts can be combined to form the different vessel's alternatives.
4. Qualitative description of the HLPs  
The fourth step is associated with the way that the HLPs are parameterized. The qualitative description will be the guideline for the mathematical representation.
5. Mathematical representation of the HLPs  
The mathematical description of the HLPs is derived from their qualitative description. Here their interrelations are defined, and from this, the vessel's architecture can be created.

6. Define the HLPs for each “total ship” architecture  
The selected HLPs from the vessel's toolkit are combined to form the “total ship” architecture according to the design decisions of the Naval Architect. The different design decision combinations lead to different solutions in the design space.
7. Tune the HLPs to fit the design problem  
The selected HLPs are then tuned to fit the specific design problem. The design requirements are used as guidelines to form feasible and suitable design solutions for the design problem.
8. Extract and evaluate the geometric model  
The output of the framework is the geometric model of the vessel for the Naval Architect to visualize their ideas and use the model as an input for analysis. The case study presented here uses NAPA software for this visualization; however, this step can be performed by other software packages as well according to design needs and preferences. Besides, a first weight and stability analysis based on semi-empirical methods should also be included in this step to give an idea about the feasibility of the design solution.

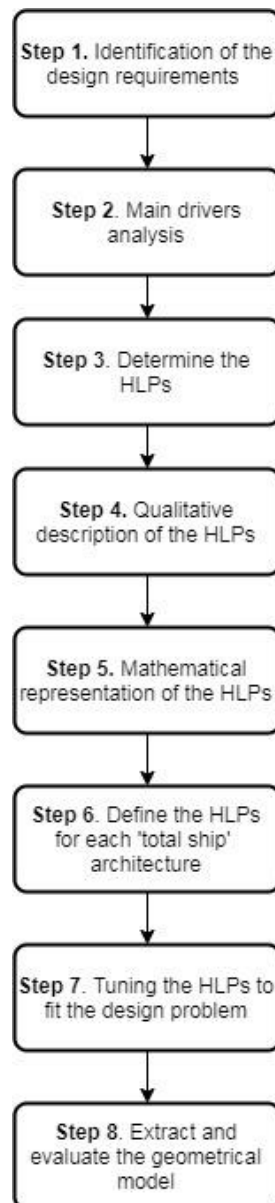

Fig.2: Flowchart of the proposed method

The proposed method was developed generically to apply to different vessel types and to fulfil different design problems. However, to bound the research work, a proof of concept was built based on the parametric modelling of an LNGBV. In addition, the case study was tailor-made for C-Job Naval Architects. In the context of C-Job design tools, all the relevant knowledge was gathered to be used for the building of the HLPs and the tailoring of the case study according to the company's design process. Further information can be found in *Charisi (2019)*.

The sources of the company's intellectual capital, which were used, included:

- Interviews from Naval Architects to understand the company's design process and design way of thinking.
- Datasets of machinery components from manufacturers.
- RefWeb tool (in-house developed data visualization tool for design intelligence and big data analysis).
- Naval architectural empirical design rules.
- Classification rules and regulations.

## **5. Case study: Preliminary design of the LNGBV**

The preliminary design of the LNGBV is examined as a case study. The LNGBV was selected to be examined because there are just a few vessels built and as a consequence, its design can not be reliably based on design trends of reference vessels. In addition, the demand for building LNGBVs is expected to increase due to the wider adoption of LNG as a marine fuel; the use of LNG lowers the polluting emissions, and thus, the compliance with the stringent IMO's regulatory framework can be achieved, *Kim et al. (2019)*. The LNG bunkering infrastructure forms a key point on the establishment of LNG as a marine fuel, *Jingjing et al. (2015)*. However, the ship-to-ship (S-T-S) bunkering around the world brings new opportunities as unlike a fixed LNG terminal, it is not dependent on location. At the moment, several LNG bunkering vessels are operating worldwide, which are either custom-built, small LNG carriers converted to bunkering vessels, or bunker barges (pushed or self-propelled), *Charisi (2019)*.

From a design point of view, the LNGBV has similarities with the LNG carrier. However, there are also significant differences, such as their operational profile. The LNG carrier is an ocean-going vessel transporting cargo worldwide, while the LNGBV aims to bunker other vessels. Thus, the LNGBV has less capacity and sails for short distances. According to naval architects at C-Job, the significant components of both of these vessels are the following: the LNG cargo containment system, the propulsion system, the boil-off gas (BOG) handling system, the inert gas system, the bunkering equipment, the S-T-S equipment, and the superstructure. A unique characteristic of the propulsion unit of the LNG carriers is that the BOG from the cargo can be used in different ways. The most common way is that the BOG is being used as a fuel source for propulsion. The LNGBV differentiates itself from the LNG carrier in its high manoeuvrability capabilities connected with safety during port operation and S-T-S bunkering process.

### **5.1 Application of the proposed method to the design of the LNGBV**

The proposed method is applied step-by-step to the design of an LNGBV. A detailed description of the steps is given.

#### **5.1.1 Identification of the design requirements**

In order to define the design requirements, a real design problem of C-Job was considered. A detailed description contains proprietary details. Thus, the detailed client's requirements were simplified to approach a more generic form of the problem. Design requirements were set related to the following:



1. The LNG cargo capacity and the LNG cargo handling system layout.
2. The required service speed and propulsion layout
3. Manoeuvrability characteristics.
4. Compliance with the applicable regulations, codes and standards related to the preliminary design stage.
5. The technical systems for the BOG treatment and the inert gas system.
6. The crew accommodation.
7. Ballast water storage.

### 5.1.2 Main drivers analysis

The main drivers analysis aims to identify the vessel's parts, which will be parameterized. The starting point is the identification of the vessel's required functions resulting from the design requirements. Regarding the LNGBV, the required functions of the vessel are to float, move, manoeuvre, navigate, transport LNG cargo, bunker other vessels, accommodate crew, and ensure safe operation. Thus, these functions were mapped to the required vessel's systems, Table I.

Table I. Mapping LNGBV functions to LNGBV systems

	Float	Move	Manoeuvre	Navigate	Transportation of LNG cargo	Bunkering operations	Accommodate crew	Ensure safety
Hull	✓							
Propulsion system		✓	✓					
Cargo handling system					✓			
Bunkering equipment						✓		
BOG handling system								✓
Inert gas system								✓
Ballast water system						✓		
Thrusters		✓	✓					
Rudder			✓					
Superstructure							✓	
Bridge				✓				

Specifically, the hull of the vessel ensures that the vessel is floatable. The propulsion system and the thrusters (if azimuth thrusters are selected) are responsible for the sailing of the vessel. The main systems influencing the vessel's manoeuvrability are the selected propulsion system, the thrusters (azimuth and bow), and the rudder. The LNG cargo handling system should also be included in order to ensure the transportation of the LNG cargo. The bunkering equipment and the ballast water system ensure bunkering operations. Safety is a significant aspect to be taken into account for the design of this vessel's type; therefore, BOG handling system and inert gas system are also included. Finally, the superstructure and the bridge are included in the design to accommodate the crew and to enable navigation.

### 5.1.3 Determine the HLPs

Following the main drivers analysis, the HLPs are defined. The HLPs can be seen as the building blocks, which can be combined to form the LNGBV. The HLPs can be re-shaped following different design decisions to form another design solution. The required systems resulted from the main drivers analysis are the hull, the propulsion system, the cargo handling system, the bunkering equipment, the

BOG handling system, the inert gas system, the ballast water system, the thrusters, the rudder, the superstructure, and the bridge. For this specific case study, these systems were filtered and translated into HLPs by taking into account the properties of the expected outcome, the NAPA geometric model. The hull was translated into three different HLPs, namely the aft hull, mid hull, and fore hull. This decision was made to enhance the flexibility of generating different hull shapes. The HLP Engine Room corresponds to the propulsion system of the vessel. Similarly, the HLP Cargo Space is equivalent to the cargo handling system. The inert gas system and the BOG handling system are combined to form the HLP of the Technical Space. The ballast water system results from the vessel's design. Thus, it is not an influential design entity that should be taken into account. The HLP Superstructure contains the superstructure and the bridge. The bunkering equipment, the stern thrusters, and the rudder are not taken into account since these entities do not add information to the geometric model at this design stage. The HLP Bow Thruster Room was developed to accommodate the bow thruster system. Finally, the HLPs Aftpeak and Forepeak were defined for geometrical purposes.

To summarize, the HLPs which will be used for the synthesis of the LNGBV are the following:

1. Engine room
2. Cargo space
3. Superstructure
4. Technical space
5. Bow thruster space
6. Aftpeak space
7. Forepeak space
8. Aft hull part
9. Mid hull part
10. Fore hull part

#### 5.1.4 Qualitative description of the HLPs

The qualitative description of the HLPs forms the basis for their mathematical representation. In order to proceed with the qualitative description of the HLPs, the sub-parts of the HLPs which should be taken into account should be defined.

An example is given for the engine room. A detailed description of this step can be found in *Charisi (2019)*. According to Wärttilä Encyclopedia of Marine Technology, the engine room is defined as the compartment onboard a ship that includes the main propulsion machinery as well as the control room, the auxiliary machinery, and other equipment. The engine room layout, design, and arrangement are governed by SOLAS- International Convention for the Safety of Life at Sea Ch.II-1 Part C, and IGF code.

According to *Klein Woud and Stapersma (2002)*, the following spaces will form the typical layout of the engine room of a small cargo vessel:

- a main machinery space including the propulsion engine, gearbox transmission, diesel generators and auxiliaries
- a steering gear room, which is located above the rudder
- a workshop, in which maintenance is carried out
- a control and/or main switchboard room

Regarding the required level of detail for the preliminary design phase, the following aspects are considered to be the design drivers for the engine room layout:

- type of propulsion
- selected machinery components
- type of propulsor(s)

- required propulsive power
- required electrical power
- requirements for manoeuvrability

An example layout for the direct mechanical drive engine room for the LNGBV is shown in Fig.3.

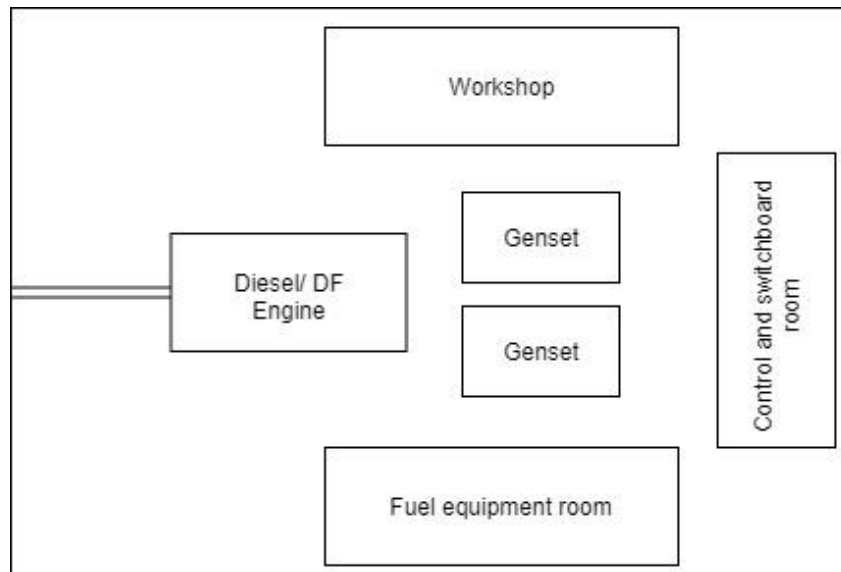

Fig.3: Direct mechanical drive engine room layout

### 5.1.5 Mathematical representation of the HLPs

Each HLP forms a class containing the relevant attributes and methods which are required to create the design solution. Regarding the case study, the expected outcome is the NAPA parametric model of the vessel and an estimation to ensure initial stability and buoyancy. Therefore, four different methods were developed for each HLP associated with their definition, tuning, geometrical representation, and weight estimation.

In general, for each HLP the following equations apply:

$$\begin{aligned}
 Length_i &= f1_i(IndependentVariables_i) \\
 Width_i &= f2_i(IndependentVariables_i) \\
 Height_i &= f3_i(IndependentVariables_i) \\
 Weight_i &= f4_i(IndependentVariables_i) \\
 GeometricModel_i &= f5_i(IndependentVariables_i)
 \end{aligned}$$

Therefore, the main dimensions of the vessel are defined as follows:

$$\begin{aligned}
 Lpp &= \sum Length\ Inner\ Blocks \\
 Beam &= \max(Width\ Inner\ Blocks) \\
 Height &= \max(Height\ Inner\ Blocks) \\
 Depth &= Draft + Min\ Required\ Freeboard
 \end{aligned}$$

The HLPs are modelled based on Object Oriented Programming (OOP) principles. Python was chosen for the development of the HLPs. The reasoning is that Python is a user-friendly coding language, which is open-source and is supported by an active and growing community of users.

### 5.1.6 Define the HLPs for each “total ship” architecture

Metaphorically, step 6 can be visualized as picking the appropriate “lego bricks” from the vessel's

“tool kit”. To do this, there are three sub-processes. Firstly, the design requirements and the naval architect’s decisions are defined. Then, the relevant knowledge is retrieved from the company’s databases. Finally, the required HLPs are defined.

### **5.1.7 Tune the HLPs to fit the design problem**

It should be noted that up to this step, all the dimensions of the HLPs are set to zero. Step 7 is associated with the method of tuning the HLPs to form a solution suitable for the specific design problem. The process consists of two sub-processes, namely the tuning of the parameters of each HLP, and the balancing of the parameters of the individual HLPs to create a feasible design solution.

The sub-process of tuning the parameters for the individual HLPs starts with the load balance analysis for the LNGBV. The primary electric consumers for this vessel are the inert gas system, nitrogen generation system, the bunkering systems, the voyage fuel supply system, the bow thruster and the general ship systems (deck equipment, engine room equipment, ventilation, heating, workshop, domestic facilities, cargo room equipment). A first prediction of the required propulsion power is taken from the reference vessel’s data stored in the RefWeb. In turn, the individual HLPs are tuned and as a result, the design solution is developed. By taking this design solution as a starting point, the HLPs are re-tuned in order to form a balanced design solution.

### **5.1.8 Extract and evaluate the geometrical model**

The subprocesses of the final step can be divided into the development of the parametric model and its assessment. For the development of the parametric model, the geometric model of the HLPs is created in NAPA. For the assessment of the design solution, the regulation regarding the minimum freeboard area, the initial stability, the manoeuvrability requirement, the ballast capacity are checked.

## **5.2 Results**

The design of an LNGBV of 7,500 m<sup>3</sup> capacity with a service speed of 12 kn, high manoeuvrability, and accommodation for 14 crew members is examined. Different design options were developed by adopting different options for the LNG cargo handling system layout, the propulsion layout, the positioning of the technical spaces and the superstructure. Indicatively, the parametric models for 4 different designs are shown in Figs.4-7. Their characteristics are presented in Table II. It should be noted that each design is developed within five to ten minutes.

For the first design solution, the propulsion system consists of a hybrid drive (two dual-fuel (DF) engines, two electric motors, and four generator sets). For the storage of the cargo, two bilobe tanks were considered. The superstructure was positioned fore to improve visibility. The technical space, which includes the inert gas system and the GCU, is positioned on the forepart of the vessel. There is also the option to include a reliquefaction plant placed on the deck.

Regarding the second design solution, the use of a membrane tank for the cargo handling system was examined. Direct mechanical drive consisting of two DF engines and two fixed pitch propellers (FPP) was selected. Two generator sets provided the required power for electric consumers. The superstructure is positioned on the aft part of the ship. A bow thruster was included to enhance manoeuvrability and compensate for the limited manoeuvrability of the mechanical drive propulsion system. The technical space was placed on the deck.

For the third design solution, it was decided to examine the use of cylindrical tanks for the LNG storage. For the propulsion layout, it was selected to use a mechanical drive consisting of two diesel engines driving two FPP. A bow thruster is also included and the superstructure was placed in the aft since more deck space was available at the aft. For the fourth design option, the use of four cylindrical tanks was examined. Diesel-electric propulsion was selected (the generator sets were positioned on the engine room on the forepart), and the technical spaces were placed on the aft (inert

gas system and GCU). The superstructure was placed in the fore to enhance visibility. The developed NAPA models are functional and can be used for further stability and strength calculations within NAPA.

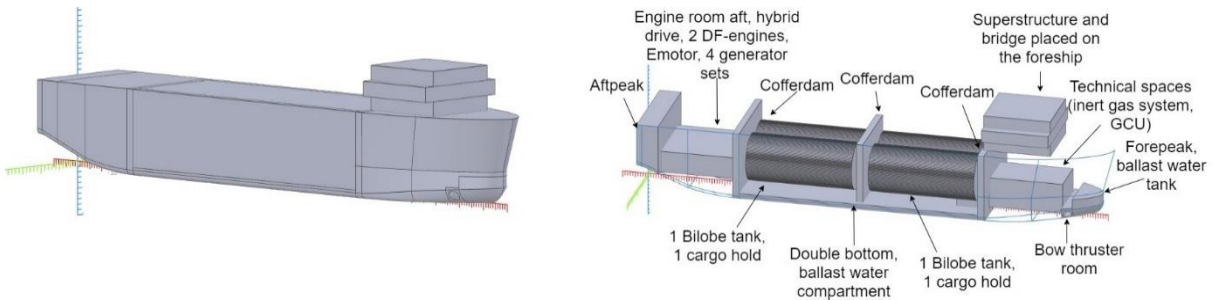

Fig.4: Design solution I (bilobe tanks, hybrid propulsion system)

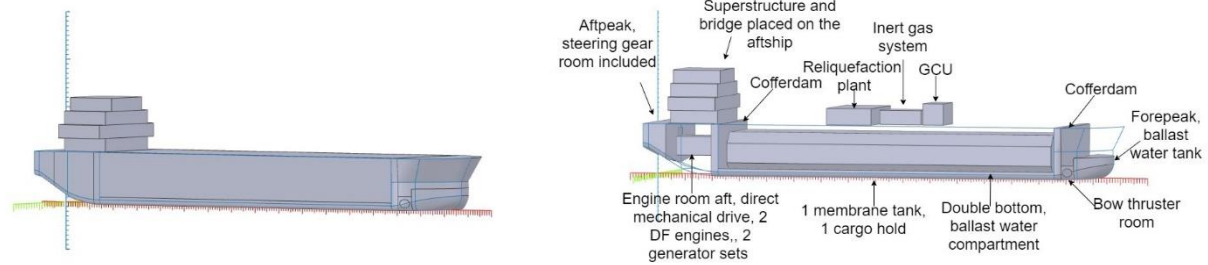

Fig.5: Design solution II (membrane tank, mechanical propulsion system)

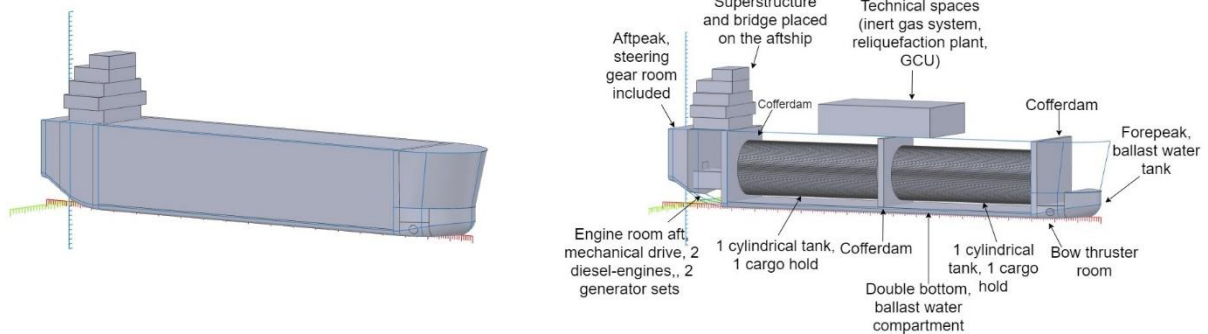

Fig.6: Design Solution III (cylindrical tanks, mechanical propulsion system)

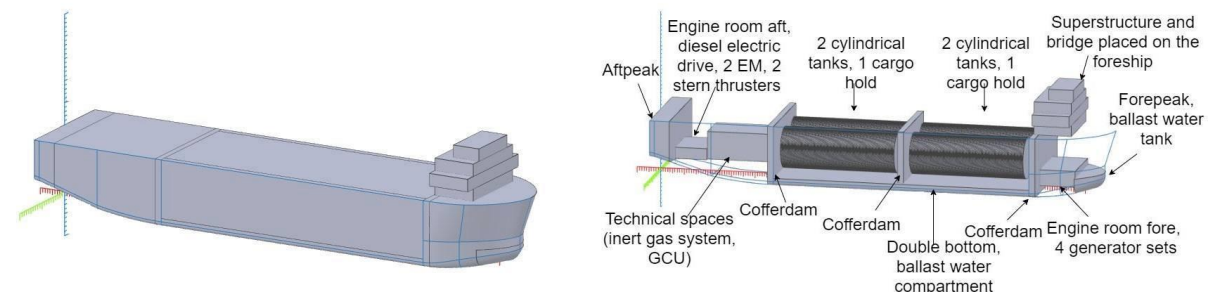

Fig.7: Design Solution IV (cylindrical tanks, diesel-electric propulsion system)

By taking into account the design cases, it can be seen that the leading factor for determining the length and the beam of the vessel is the cargo room layout. Other influential parameters were the selection of the propulsion layout and the positioning of the technical spaces on the forehull, aft hull, or on the deck. Therefore, by developing different variations of the HLPs and using them to create different design solutions the naval architect can visualize and understand the impact of the major design decisions to the vessel, the LNGBV in this case.

Table II. Characteristics of the design solutions

<b>LNGBV 7500 LNG</b>				
	<i>Design Solution I (bilobe tanks, hybrid propulsion system)</i>	<i>Design Solution II (membrane tank, mechanical propulsion system)</i>	<i>Design Solution III (cylindrical tanks, mechanical propulsion system)</i>	<i>Design Solution IV (cylindrical tanks, diesel-electric propulsion system)</i>
<b>GENERAL</b>				
Length overall	109.54m	102.87m	110.40m	115.82m
Length b.p.p	106.86m	100.36m	107.71m	113.00m
Beam moulded	22.00m	24.00m	19.00m	27.00m
Height	16.00m	11.00m	18.00m	15.00m
Depth(min)	6.5m	5.8m	7.5m	5.50m
Draft	5.13m	4.6m	6.07m	4.10m
Lightshipweight	6350t	4740t	6680t	6680t
Block Coefficient	0.80	0.73	0.80	0.81
Deadweight	3750t	3750t	3750t	3750t
Total installed power	3300kW	2700kW	3570kW	3600kW
Inert gas system	YES	YES	YES	YES
GCU	YES	YES	YES	YES
Reliquefaction plant	OPTION	YES	YES	OPTION
<b>TANK CAPACITIES</b>				
Ballast water	3900 m <sup>3</sup>	4480m <sup>3</sup>	5300m <sup>3</sup>	5330m <sup>3</sup>
<b>PERFORMANCE</b>				
Speed (at the design draft and 100% MCR)	12 knots	12 knots	12 knots	12 knots
<b>PROPULSION SYSTEM</b>				
	Hybrid drive, 4 diesel generator sets, 2 electric motors driving the 2 azimuth thrusters	Mechanical drive, 2 diesel generator sets, 2 DF engines, 2 FPP	Mechanical drive, 2 diesel generator sets, 2 DF engines, 2 FPP	Diesel electric drive, 4 diesel generator sets, 2 electric motors, 2 azimuth thrusters
<b>ACCOMMODATION</b>				
Crew (Single Cabins)	14 people	14 people	14 people	14 people

## 6. Discussion and Conclusions

The present research work proposes a parametric modelling method based on the principles of KBE. The case study focused on the preliminary design of the LNGBV. The main idea of the technique was the development of the parametric models based on the combination of the different building blocks, the HLPs. The HLPs can be seen as lego bricks, which can change shape, size, and re-order according to the design case and the Naval Architect's decisions.

The significant benefit of the proposed method is that each parametric model is automatically developed within a few minutes. In turn, the generated solutions can be further evaluated with analysis tools. As a result, the Naval Architect is able to perform a broader exploration of the design space and thus, come up with improved designs developed in shorter lead times. In contrast to repetitive engineering work for developing the parametric models, the Naval Architect is committed to creative tasks such as figuring out which design decisions should be examined for each design problem, which is their impact to the final design, which different design variations should be further

examined and optimized.

## 7. Recommendations for future research

The results of the application of the proposed method to the LNGBV are promising. The presented case study is a self-contained proof of concept, which shows potential in the automation of parametric modelling by using the KBE methodology. However, further research is suggested to harness its full potential.

From a design perspective, it is worthwhile to develop an HLP toolkit to address the design of different ship types. As a first step, the proposed parametric modelling method should be validated for the design of different vessel types with geometrical similarities. As a next step, it is suggested to develop a parametric modelling method to address the design of vessels with radically different geometrical features. This improvement will lead to the exploration of more innovative design concepts.

In order to compare the different solutions, their performance should be assessed. Therefore, research and integration of performance functions into the proposed framework will enable the assessment of the developed design variations. The interface of the proposed framework with the suitable state-of-the-art analysis tools will enable the calculation of each design's performance. Finally, an optimization loop can be also implemented to generate optimized designs according to the design problem. In the context of C-Job Naval Architects, it is suggested to develop the connection with the Accelerated Concept Design (ACD), which is the in-house developed optimization tool based on a surrogate assisted optimization algorithm, the Constrained Efficient Global Optimization (CEGO) algorithm, *de Winter et al. (2019a,b)*.

## Acknowledgements

The present paper is part of the research carried out in the context of the first author's Master thesis, which was conducted in TU Delft in cooperation with C-Job Naval Architects.

## References

- ARENDRT, R.; VAN UDEN, E. (2011), *A decision-making module for aiding ship system automation design: A knowledge-based approach*. *Expert Systems with Applications*, 38(1), pp.410-416
- BILIOTTI, I.; BRIZZOLARA, S.; VIVIANI, M.; VERNENGO, G.; RUSCELLI, D.; GALLIUSI, M.; MANFREDINI, A. (2011), *Automatic Parametric Hull Form Optimization of Fast Naval Vessels*, 11<sup>th</sup> Int. Conf. Fast Sea Transportation (FAST 2011)
- BRIZZOLARA, S.; VERNENGO, G.; PASQUINUCCI, C.; HARRIES, S. (2015), *Significance of parametric hull form definition on hydrodynamic performance optimization*, MARINE 2015 - Computational Methods in Marine Engineering VI, pp. 254-265
- BRUINESSEN, T.; HOPMAN, H.; SMULDERS, F. (2013), *Towards a Different View on Ship Design: The Development of Ships Observed Through a Social-Technological Perspective*, Int. Conf. Offshore Mechanics and Arctic Engineering - OMAE. 1, 10.1115/OMAE2013-11585
- CALLEYA, J.; PAWLING, R.; RYAN, C.; GASPAR, H. (2016), *Using Data-Driven Documents (D3) to explore a Whole Ship Model*, 11<sup>th</sup> System of Systems Engineering Conf. (SoSE), 10.1109/SYSOSE.2016.7542947
- CHARISI, N.D. (2019), *Parametric Modelling Method based on Knowledge Based Engineering: The LNG Bunkering Vessel Case*, MSc thesis, TU Delft, <http://resolver.tudelft.nl/uuid:5321df04-39e6-4128-9eec-c3adcac8a68a>

- COOPER, S.; FAN, I.; LI, G. (2001), *Achieving competitive advantage through knowledge based engineering – a best practice guide*, Department of Trade and Industry
- DAHL, D.; CHATTOPADHYAY, A.; GORN, G. (2001), *The importance of visualisation in concept design*, Design Studies 22/1, pp.5-26
- DE WINTER, R.; VAN STEIN, B.; DIJKMAN, M.; BÄCK, T. (2019a), *Designing ships using constrained multi-objective efficient global optimization*, Machine Learning, Optimization, and Data Science, Springer, pp.191–203
- DE WINTER, R.; FURUSTAM, J.; BÄCK, T.; MULLER, T. (2019b), *Optimizing Ships Using the Holistic Accelerated Concept Design Methodology*, 14<sup>th</sup> Int. Symp. Practical Design of Ships and Other Floating Structures (PRADS 2019), Yokohama
- DUCHATEAU, E.A.E. (2016), *Interactive evolutionary concept exploration in preliminary ship design*, PhD, TU Delft, <https://doi.org/10.4233/uuid:27ff1635-2626-4958-bcdb-8aee282865c8>
- ERIKSTAD, S.O. (2007), *Efficient Exploitation of Existing Corporate Knowledge in Conceptual Ship Design*, Ship Technology Research 54/4, pp.184-193
- GASPAR, H.M. (2018), *Data-Driven Ship Design*, COMPIT Conf., Pavone
- JINGJING X.; DAVID T.; PROSHANTO K. M. (2015), *The Use of LNG as a Marine Fuel: The International Regulatory Framework*, Ocean Development & International Law 46/3, pp.225-240
- HERNANDEZ, C. (2006), *Thinking parametric design: Introducing parametric Gaudi*, Design Studies 27, pp.309-324
- KANELLOPOULOU, A.; KYTARIOLOU, A.; PAPANIKOLAOU, A.; SHIGUNOV, V.; ZARAPHONITIS, G. (2019), *Parametric ship design and optimisation of cargo vessels for efficiency and safe operation in adverse weather conditions*, J. Marine Science and Technology 24/4, pp.1223-1240
- KIM, K.; PARK, K.; ROH, G.; CHUN, K. (2019), *Case Study on Boil-Off Gas (BOG) Minimization for LNG Bunkering Vessel Using Energy Storage System (ESS)*, J. Marine Science and Eng. 7/5, 130
- KLEIN WOOD, H.; STAPERSMA, D. (2002), *Design of Propulsion and Electric Power Generation Systems*, IMarEST publications, IMarEST
- LA ROCCA, G.; VAN TOOREN, M. (2010), *Knowledge-based engineering to support aircraft multidisciplinary design and optimization*, J. Aerospace Eng. 224/9, pp.1041-1055
- LA ROCCA, G. (2012), *Knowledge based engineering: Between AI and CAD. Review of a language based technology to support engineering design*, Advanced Engineering Informatics 26, pp.159-179
- LA ROCCA, G.; VAN TOOREN, M.J.L. (2006), *A Modular Reconfigurable Software Modelling Tool to Support Distributed Multidisciplinary Design and Optimisation of Complex Products*, 16<sup>th</sup> CIRP Int. Design Seminar, Kananaskis
- MAISONNEUVE, J.J.; HARRIES, S.; MARZI, J.; RAVEN, H.C; VIVIANI, U.; PIIPPO, H. (2003), *Towards optimal design of ship hull shapes*, IMDC Conf., pp.31-42
- MARZI, J.; PAPANIKOLAOU, A.; CORRIGNAN, P.; ZARAPHONITIS, G.; HARRIES, S. (2018), *HOLISTIC Ship Design for Future Waterborne Transport*, 10.5281/zenodo.1436316.



NOWACKI, H. (2010), *Five decades of Computer-Aided Ship Design*, Computer-Aided Design 42, pp.956-969

PAPANDREOU, C.; PAPANIKOLAOU, A. (2015), *Parametric Design and Multi-objective Optimization of SWATH*, 5<sup>th</sup> Int. Symp. on Ship Operations, Management and Economics, Athens

PAPANIKOLAOU, A.; ZARAPHONITIS, G.; BOULOUGOURIS, E.; LANGBECKER, U.; MATHO, S.; SAMES, P. (2010), *Multi-objective optimization of oil tanker design*, J. Marine Science and Technology 15, pp.359-373

PAPANIKOLAOU, A. (2014), *Ship Design - Methodologies of Preliminary Design*, Springer

PAPANIKOLAOU, A. (2019), *A Holistic Approach to Ship Design Volume 1: Optimisation of Ship Design and Operation for Life Cycle*, Springer

PAPANIKOLAOU, A.; FLIKKEMA, M.; HARRIES, S.; MARZI, J.; NENA, R.; TORBEN, S.; YR-JANAINE, A. (2020), *Tools and Applications for the Holistic Ship Design*, Transport Research Arena TRA2020 - Rethinking Transport, Helsinki

PARSONS, M.G. (2004), *Parametric Design*, Ship Design and Construction, SNAME

REHN, C.F. (2018), *Ship design under uncertainty*, PhD, NTNU, Trondheim

PRIFTIS, A.; PAPANIKOLAOU, A.; PLESSAS, T. (2016), *Parametric Design and Multiobjective Optimization of Containerships*, J. Ship Production and Design 32, pp.1-14

SANCHES, F.M. (2016), *Parametric modelling of hull form for ship optimization*, MSc thesis, TU Lisbon, Lisbon

SCHUT, E.J.; VAN TOOREN, M.J.L (2007), *A Knowledge Based Engineering approach to automation of conceptual design option selection*, 10.2514/6.2007-968.

SCHUT, E.J.; VAN TOOREN, M.J.L. (2008), *Engineering Primitives to Reuse Design Process Knowledge*, 4<sup>th</sup> AIAA Multidisciplinary Design Optimization Specialist Conf., Schaumburg

SOBIESKI, J.; MORRIS, A.; VAN TOOREN, M.J.L. (2015) *Multidisciplinary Design Optimization Supported by Knowledge Based Engineering*, J. Wiley & Sons

TIMUR, M. (2015), *A parametric modelling tool for high speed displacement monohulls*, MSc thesis, <https://dspace.mit.edu/handle/1721.1/100091>

VAN DEN BERG, T. (2013), *Harnessing the potential of Knowledge Based Engineering in manufacturing design*, MSc thesis, TU Delft, <https://repository.tudelft.nl/islandora/object/uuid%3Ad44876fe-45dd-44ae-8947-622613eb963c>

VAN TOOREN, M.J.L; LA ROCCA, G.; KRAKERS, L.; BEUKERS, A. (2003), *Design and technology in aerospace. Parametric modelling of complex structure systems including active components*, 13<sup>th</sup> Int. Conf. Composite Materials, San Diego

WAN, J.; WANG, N.; GOMEZ-LEVI, G. (2005), *Parametric modeling method for conceptual vehicle design*, 25<sup>th</sup> Computers and Information in Eng. Conf., Long Beach, Vol.3, pp.403-410

WEI, J.H. (2016), *Parametric modelling for determining aircraft stability & control derivatives*, MSc thesis, TU Delft, <https://repository.tudelft.nl/islandora/object/uuid:cd095318-3272-400a-822d->

[e7990480a904?collection=education](http://resolver.tudelft.nl/uuid:cd095318-3272-400a-822d-e7990480a904) <http://resolver.tudelft.nl/uuid:cd095318-3272-400a-822d-e7990480a904>

WU, Y.H.; SHAW, H.J. (2011), *Document Based Knowledge Base Engineering Method for Ship Basic Design*, Ocean Engineering 38/13, pp.1508-1521

YANG, H.Z.; CHEN, J.F.; MA, N.; WANG, D.Y. (2012), *Implementation of knowledge-based engineering methodology in ship structural design*, Computer-Aided Design 44, pp.196-202