

Details booklet

CONE & DESERT

PIRAMID

Index of details
CONE & DESERT

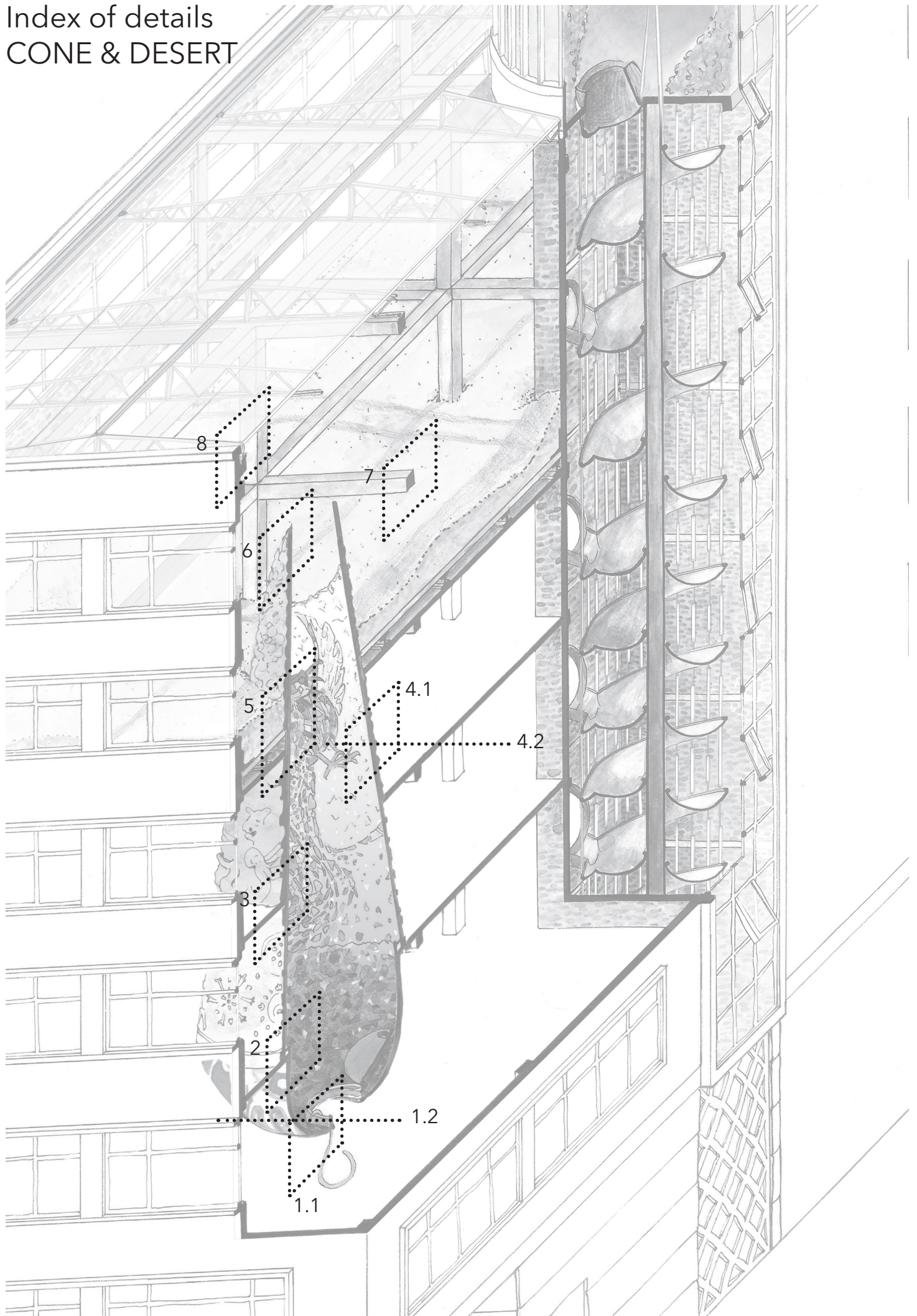

Entrance cone/audio opening and cone floor

longitudinal

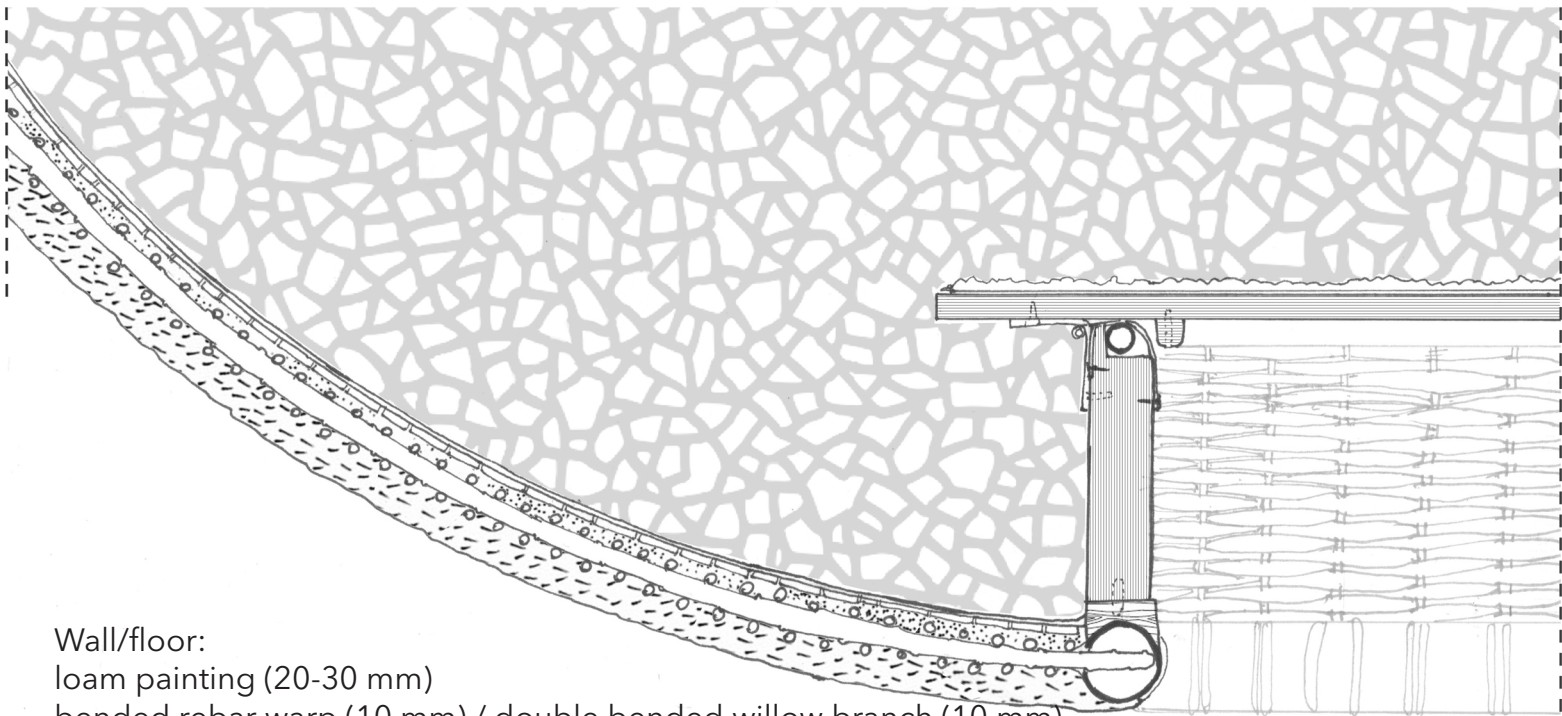

Wall/floor:

loam painting (20-30 mm)
bended rebar warp (10 mm) / double bended willow branch (10 mm)
willow twig weft (5 mm)
loam cement (15 mm)
recycled broken tiles (4 mm)
epoxy coating

One piece opening frame:

Bended stainless steel tube profile (circumfr. 50 mm)
welded solid circular connecting bar warp (curc. 5 mm) / double bended willow branch (5 mm)
willow twig weft (5 mm)
Bended stainless steel tube profile (circumfr. 20 mm)

Door:

Laminated wood plate (40 mm)
on solid wood transfer blocks
- is clamped between one piece frame -
- holds - stainless steel hinge
- and- the plywood door/lid (20 mm)
- covered with - carpet

Entrance and floor cone

horizontal

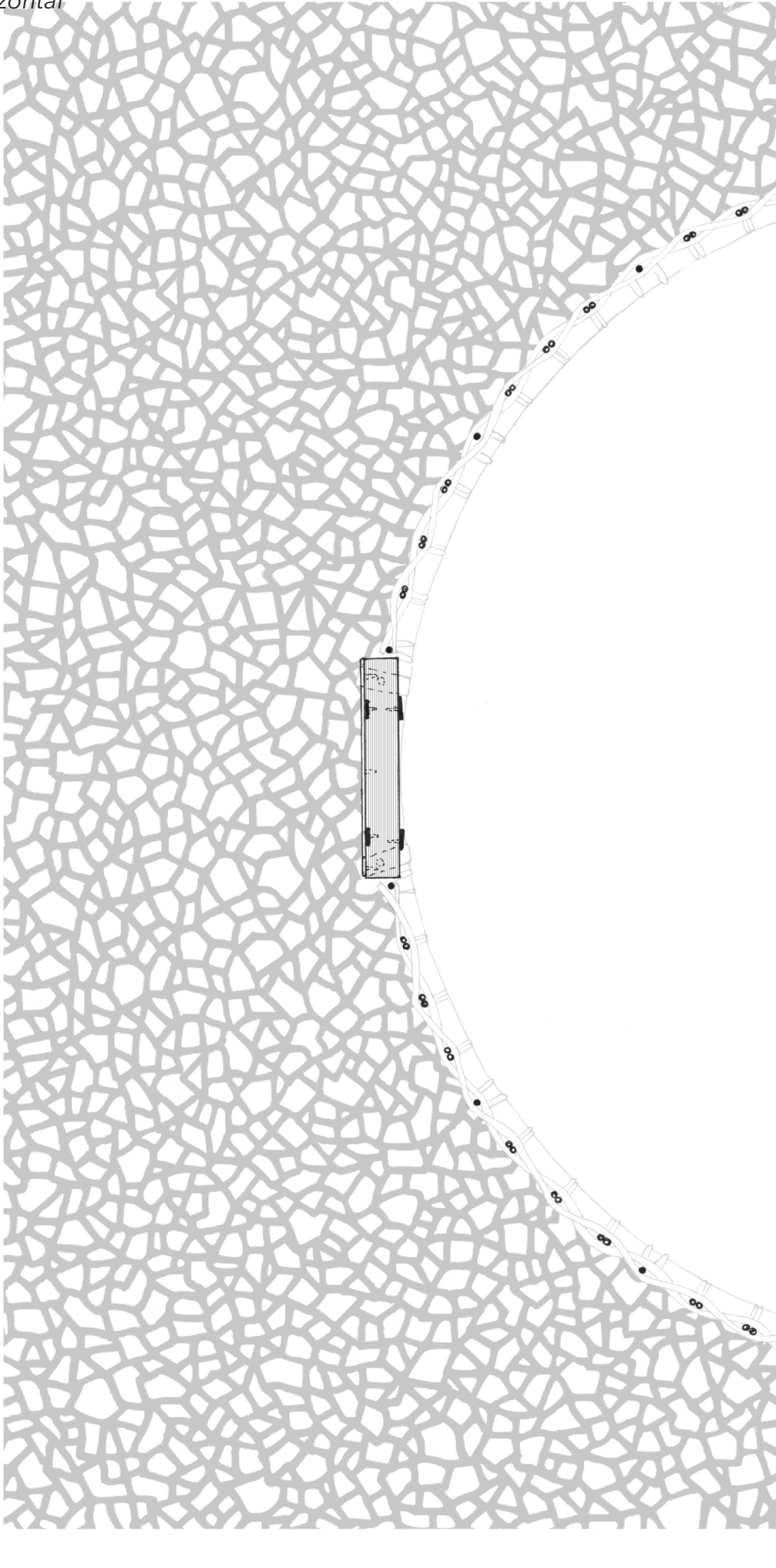

Connection cone base and old floor

longitudinal

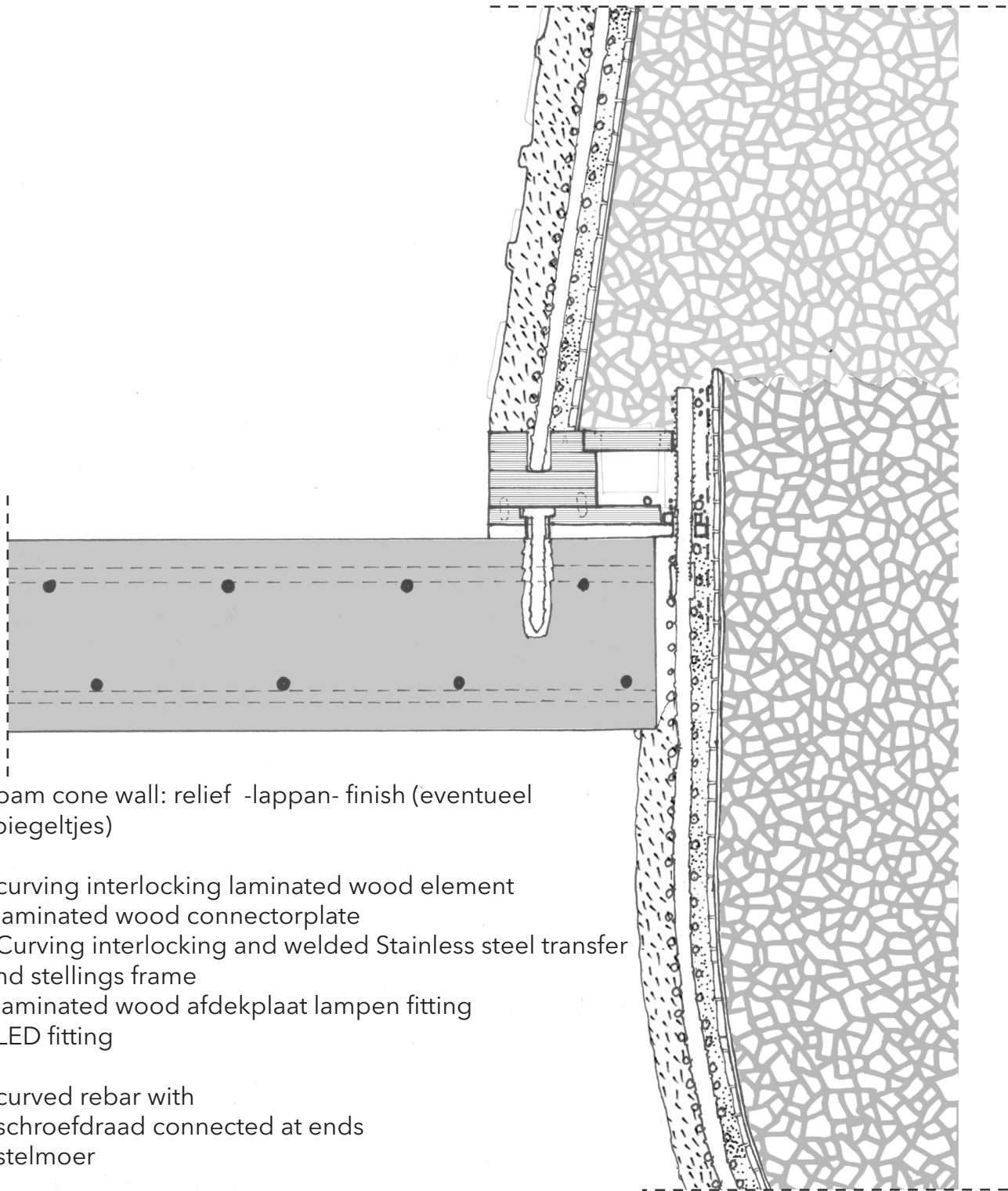

-loam cone wall: relief -lappan- finish (eventueel spiegeltjes)

- curving interlocking laminated wood element
- laminated wood connectorplate
- Curving interlocking and welded Stainless steel transfer and stellings frame
- laminated wood afdekplaat lampen fitting
- LED fitting

- curved rebar with
- schroefdraad connected at ends
- stelmoer

- rieten net geknoopt aan
- wilgen/rebars warp

- rest van vloer/wand : loam painting finish
- siliconen scheuronderbreking

Connection cone middle and old floor

longitudinal

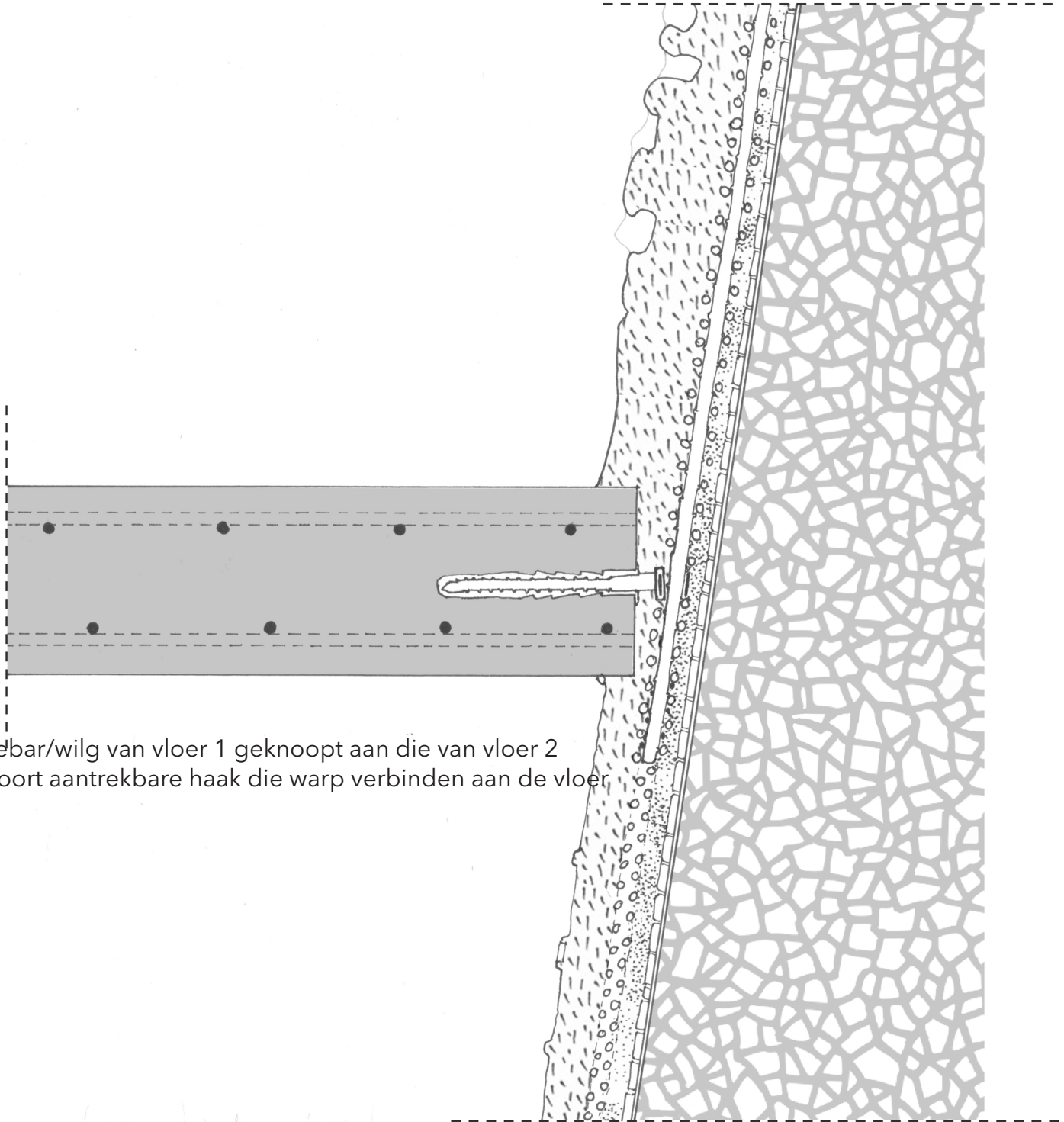

- rebar/wilg van vloer 1 geknoopt aan die van vloer 2
- soort aantrekbaar haak die warp verbinden aan de vloer

ussen over verbinding kegel

Audio openings in cone

longitudinal and horizontal

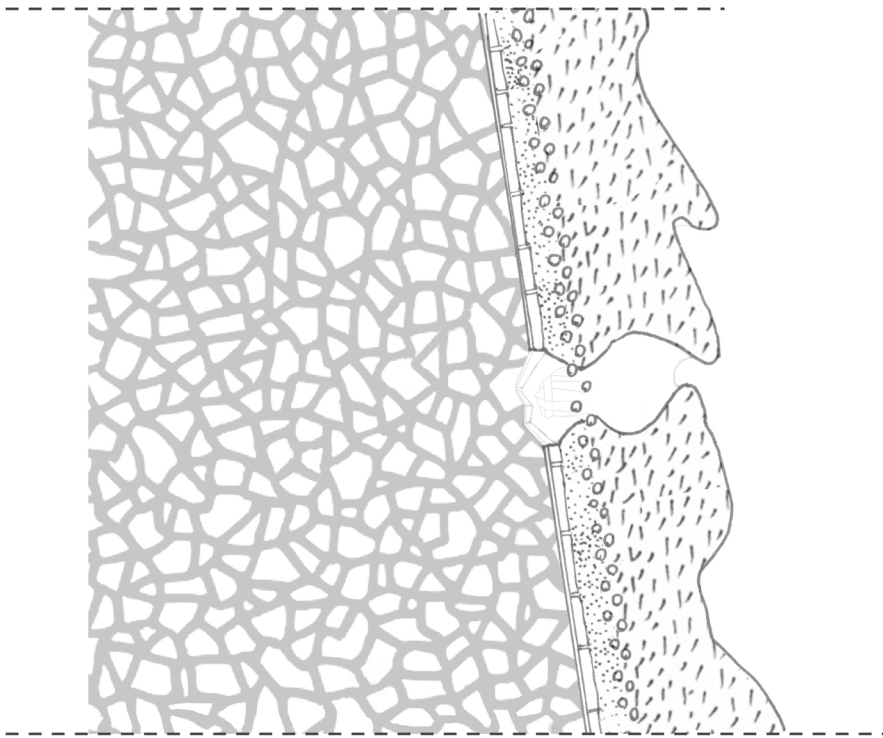

4.1

sparing in keramik tegeling en consequent
buitenleemafwerking: geluidopening

om en om rebar en willow warps



4.2

Connection cone to old floor and new desert floor

longitudinal

Staalplaatbetonvloer

I balk

prefab hole end frame with welded warp connection hooks

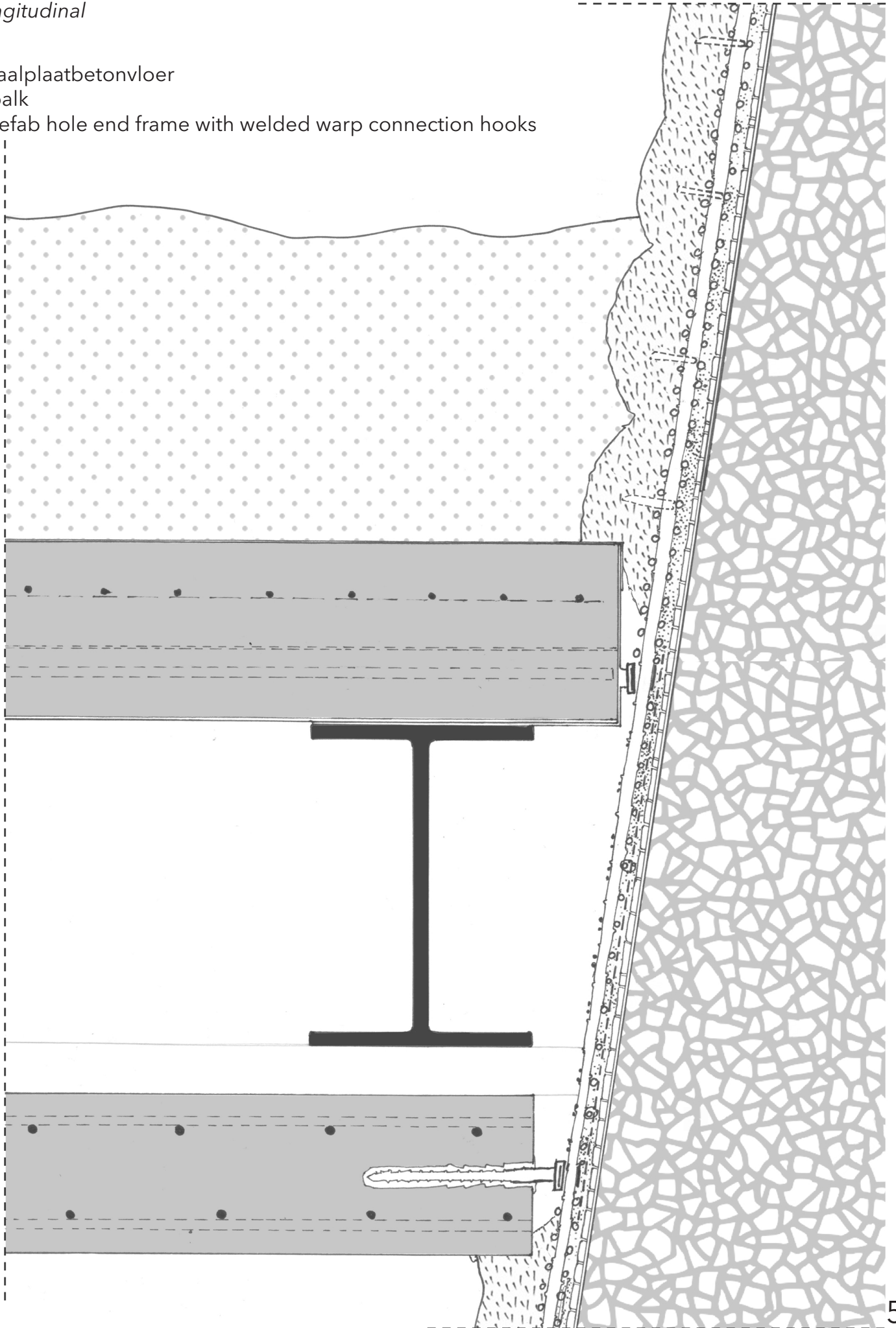

Top edge cone - audio opening

longitudinal

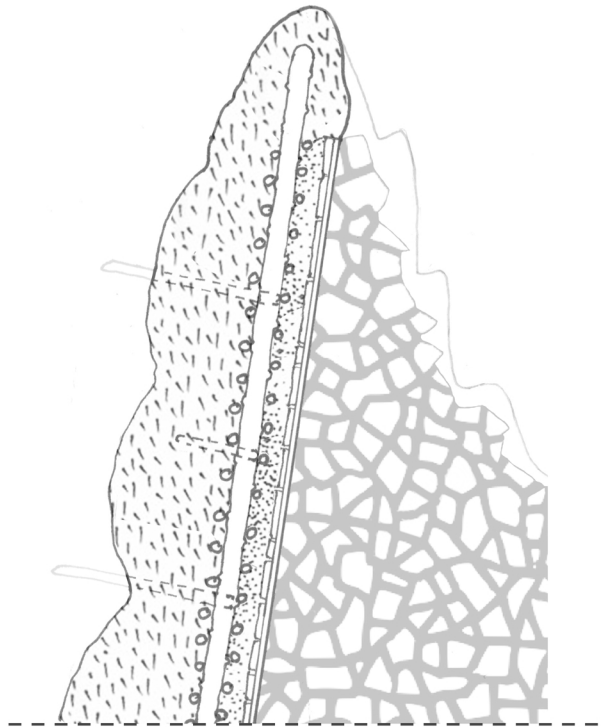

loam wall finish mud trowing event

willow pins between the weaves to grab better the loam + creates breakpatterns

Willow pins with sharp cut ends towards top: protection against climbing

Rebar and willow warps on top stick out and are covered by loam - (visual) protection against climbing

Beam, floor cuts and functional additions top level *longitudinal*

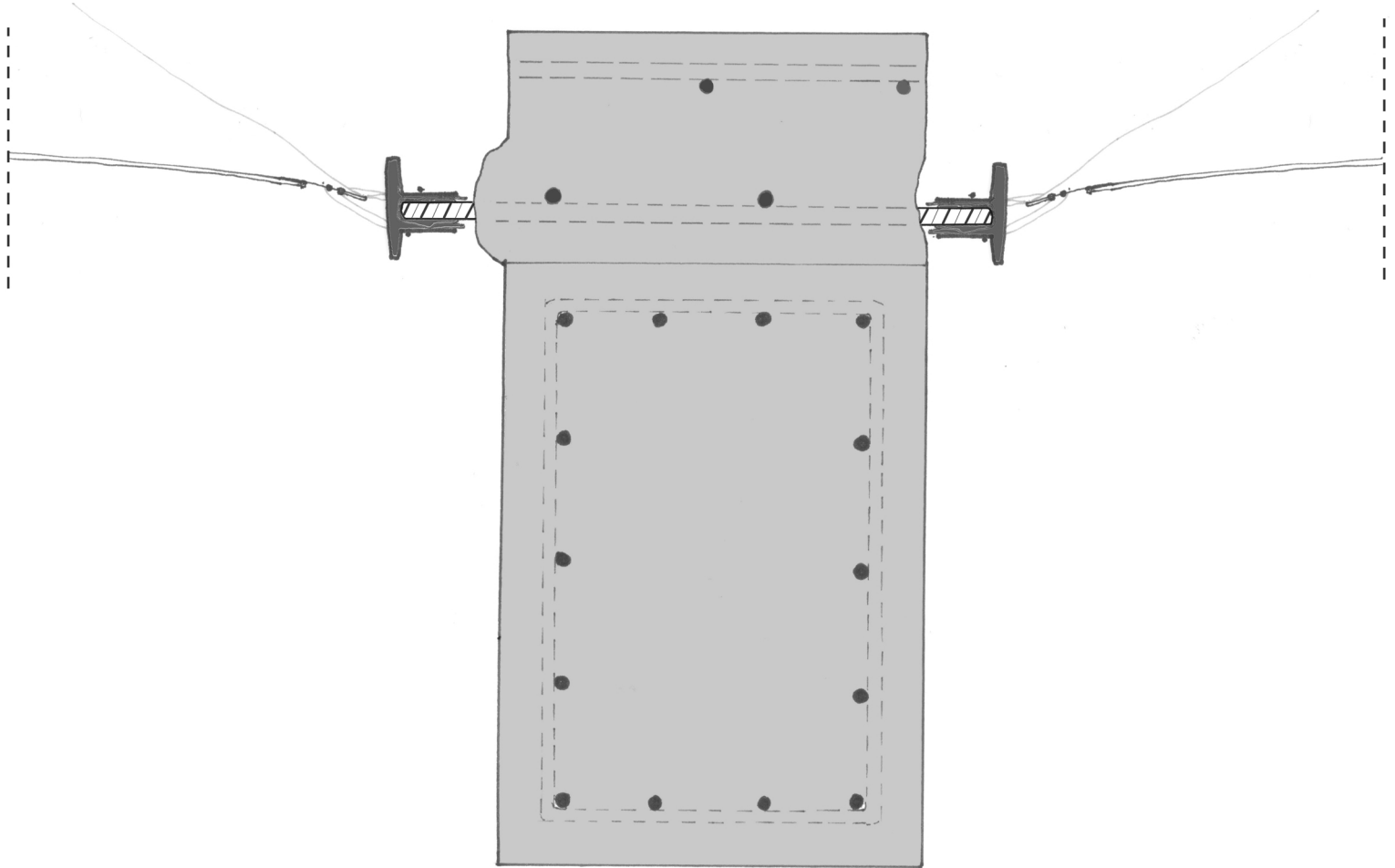

Half ingezaagde vloer
afgebroken onderkant vloer
rebar doppen monumenten
eventueel: gespannen schaduwgevend doek

Index of details
PIRAMID

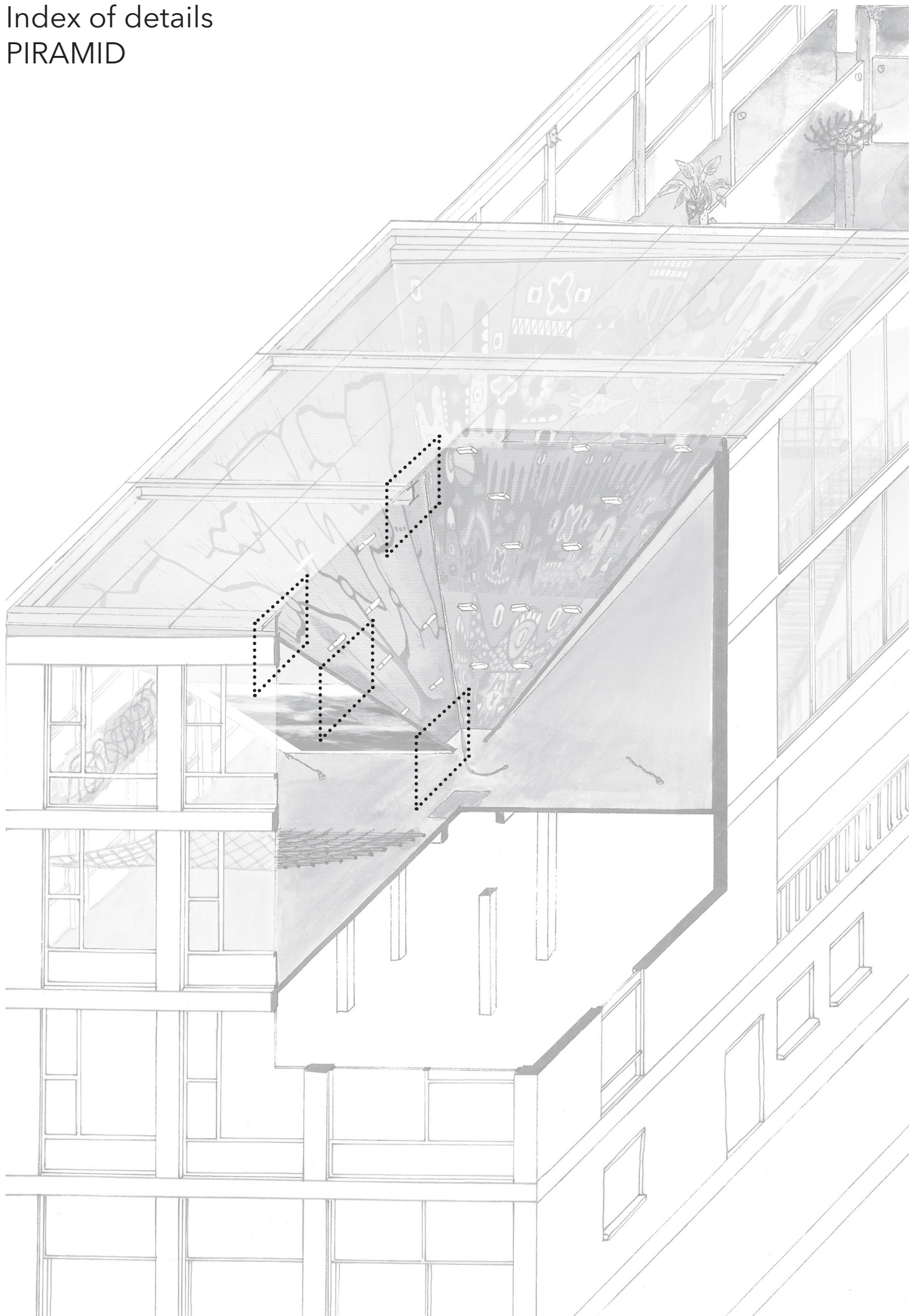

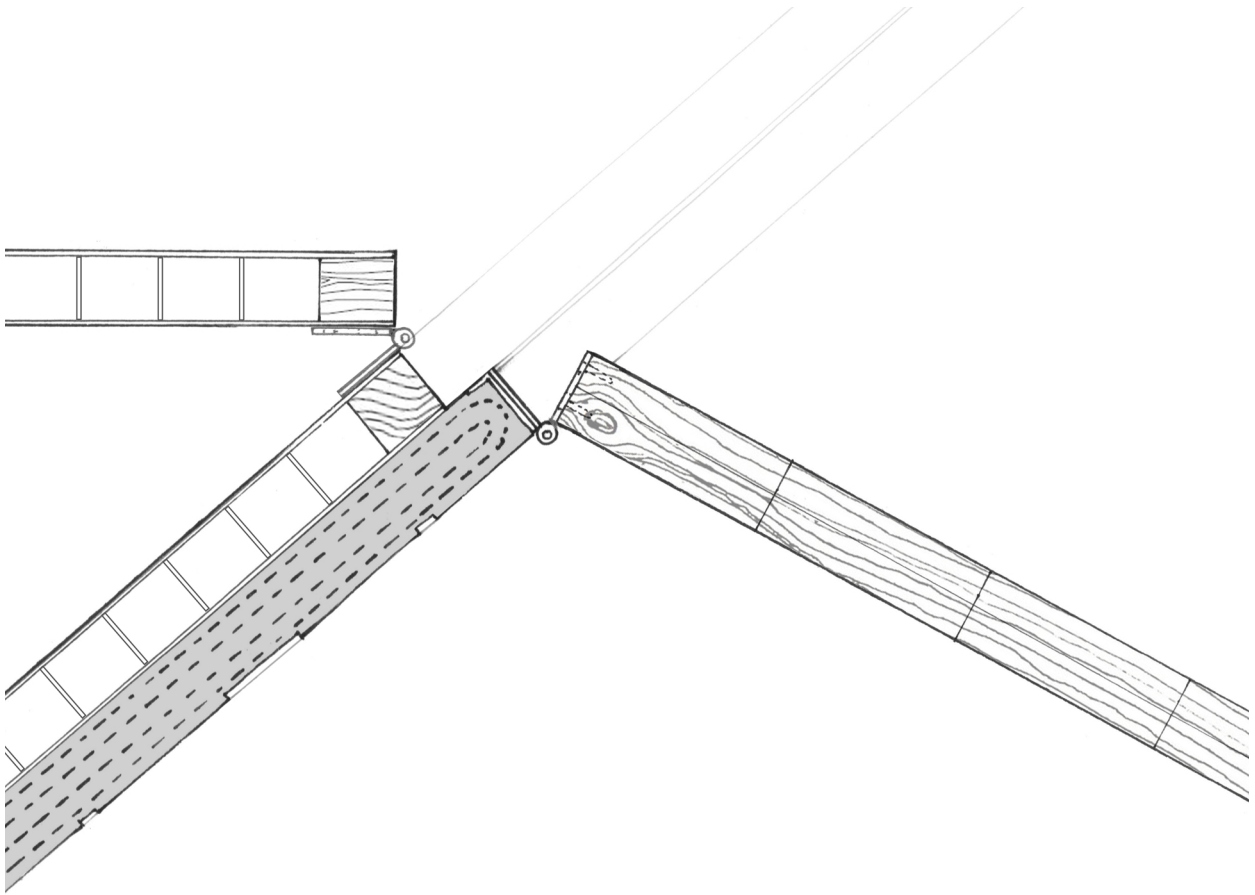

Door hinge connection
longitudinal

Wall-wall hook
longitudinal and frontview

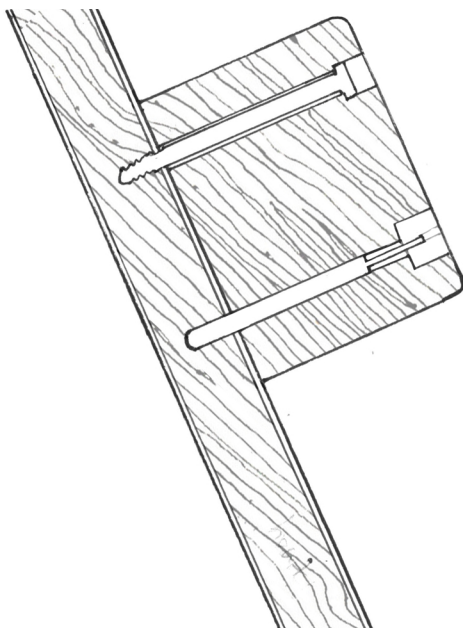

Wall hinge and corner
reinforcement
horizontal

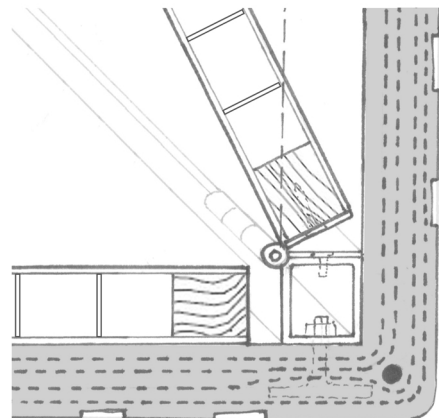

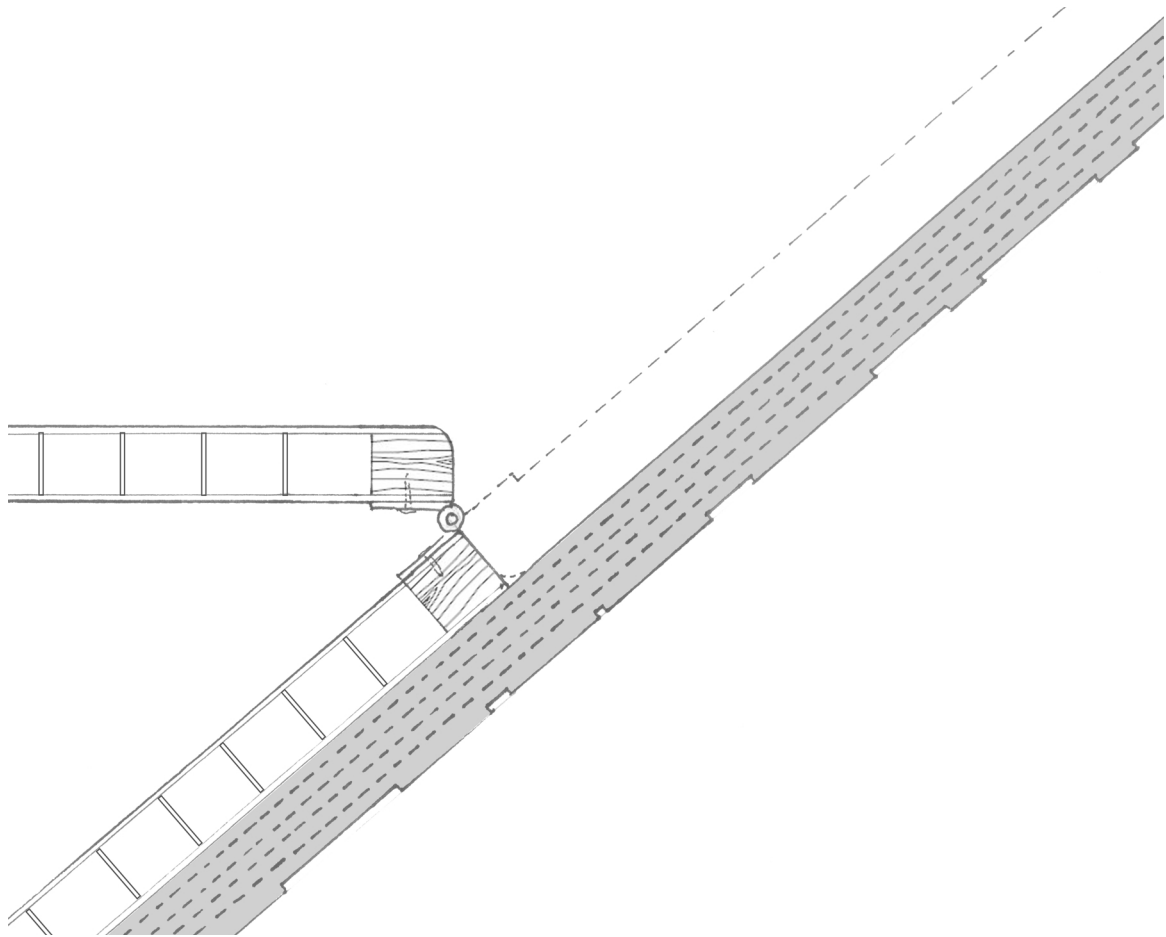

Floor hinge connection
longitudinal

Floor to wall connection
longitudinal

