

## **Under-Frequency Load Shedding in Mongolia Simulation Assessment Considering Inertia Scenarios**

Adiyabazar, Choidorj ; Acosta, Martha N.; Gonzalez-Longatt, F.; Rueda , J.L.; Palensky, P.

**DOI**

[10.1109/ISIE45063.2020.9152584](https://doi.org/10.1109/ISIE45063.2020.9152584)

**Publication date**

2020

**Document Version**

Final published version

**Published in**

2020 IEEE 29th International Symposium on Industrial Electronics, ISIE 2020 - Proceedings

**Citation (APA)**

Adiyabazar, C., Acosta, M. N., Gonzalez-Longatt, F., Rueda , J. L., & Palensky, P. (2020). Under-Frequency Load Shedding in Mongolia: Simulation Assessment Considering Inertia Scenarios. In *2020 IEEE 29th International Symposium on Industrial Electronics, ISIE 2020 - Proceedings: Proceedings* (pp. 1256-1261). Article 9152584 (IEEE International Symposium on Industrial Electronics; Vol. 2020-June). IEEE.  
<https://doi.org/10.1109/ISIE45063.2020.9152584>

**Important note**

To cite this publication, please use the final published version (if applicable).  
Please check the document version above.

**Copyright**

Other than for strictly personal use, it is not permitted to download, forward or distribute the text or part of it, without the consent of the author(s) and/or copyright holder(s), unless the work is under an open content license such as Creative Commons.

**Takedown policy**

Please contact us and provide details if you believe this document breaches copyrights.  
We will remove access to the work immediately and investigate your claim.

***Green Open Access added to TU Delft Institutional Repository***

***'You share, we take care!' - Taverne project***

**<https://www.openaccess.nl/en/you-share-we-take-care>**

Otherwise as indicated in the copyright section: the publisher is the copyright holder of this work and the author uses the Dutch legislation to make this work public.

# Under-Frequency Load Shedding in Mongolia: Simulation Assessment Considering Inertia Scenarios

Choidorj Adiyabazar  
Power System Analysis and  
Research Department  
National Dispatching Center  
Co.,Ltd  
Ulaanbaatar, Mongolia  
[choidorj.a@ndc.energy.mn](mailto:choidorj.a@ndc.energy.mn)

Martha N. Acosta  
School of Mechanical and  
Electrical Engineering  
Universidad Autónoma de Nuevo  
León  
Nuevo León, México  
[martha.acostamnt@uanl.edu.mx](mailto:martha.acostamnt@uanl.edu.mx)

F. Gonzalez-Longatt  
Institutt for elektro, IT og  
kybernetikk  
Universitetet I Sørøst-  
Norge  
Porsgrunn, Norway  
[fplongatt@fplongatt.org](mailto:flongatt@fplongatt.org)

J.L. Rueda and P. Palensky  
Department of Electrical  
Sustainable Energy  
Delft University of Technology  
(TU Delft)  
Delft, Netherlands  
[J.L.RuedaTorres@tudelft.nl](mailto:J.L.RuedaTorres@tudelft.nl)

**Abstract**—Mongolia power system (MPS) is evolving quite fast, and the integration of renewable resources (mainly wind power and solar photovoltaic) reached 20% by 2019. The MPS is interconnected to Russia in order to cover local energy deficits, especially during freezing winters. However, the interconnection to Russia is a sensible element of the MPS, especially from the frequency control and stability point of view. This situation was evident during the sudden disconnection of the two interconnecting lines that provoked the major event of 29<sup>th</sup> June 2018, disconnecting 112 MW by the action of the Under-Frequency Load Shedding (UFLS) and making more than 1.5 million without electricity that day. This paper is dedicated to using numerical time-domain simulations to assess the existing UFLS schemes installed in the MPS. As the MPS is especially sensitive to disconnection from the Russian grid, this event is used to assess the suitability of the UFLS considering two scenarios: Summer and Winter. Results of this research paper have demonstrated that the actual UFLS scheme is not enough to avoid frequency collapse in real-life conditions during the Summer low-demand and low inertia scenario.

**Keywords**—Frequency control, frequency stability, Mongolian power system, under frequency load shedding.

## I. INTRODUCTION

Mongolia is a country located in East Asia, and it has borders with Russia to the north and China to the south (see Fig. 1). Mongolia is the 18th-largest and the most sparsely populated sovereign state in the world, with a population of around three million people. Ulaanbaatar is the capital city of Mongolia, formerly anglicised as Ulan Bator, and it has a population (2014) over 1.3 million, almost half of the country's population.

The electricity sector in Mongolia ranges from generation, transmission, distribution and sales of electricity. The Mongolian government is very interested in the energy sectors as a consequence it published State Policy on Energy document in 2015, it set out plans to medium- and long-term goals of electricity energy development [1]. Renewable generation capacity will account for 20% and 30% of installed generating capacity by 2020 and 2030, respectively. Also, the Mongolian government has ambitious energy policy to address the power shortage issues [1]. However, the Mongolian Power System

(MPS) is usually loaded near to its steady-state stability limit. Thus it is more sensitive to system disturbance due to continuously rising power demand, without highspeed regulation, large power plants, and renewable energy sources generate approximately 20 per cent of total electricity generated in MPS. The operation at points near to the steady-state stability limit is a massive risk to power system stability, such that in the event of a disturbance, the possibility of cascading events, which led to total system collapse, in 2012, 2015 and 2018.



Fig. 1. Geographical location of Mongolia in East Asia, indicating borders.

One example of this stressed operation and the susceptibility of under-frequency events is the major event on 29<sup>th</sup> June 2018. During a typical summer day (load ~ 535 MW) at 23:02:58:90, the main interconnection between the Russian and Mongolian systems were disconnected due to strong wind, it caused a single phase to ground fault on lines 257 and 258. After separation from the Russian grid, a power deficit in the isolated MPS made the frequency drop quickly. Then, the emergency under-frequency measurements acted, the under-frequency load shedding was activated, and a minimum frequency of 48.47 Hz was reached, after several minutes the frequency was recovered to 49.77 Hz (see Fig. 2).

The major event of 29<sup>th</sup> June 2018 caused the disconnection of a total load of 112MW from the MPS. This disconnection affected an estimated 1.5 million people. Although the electric service was recovered in a very short time, this major event indicated the need to assess the actual Under-Frequency Load Shedding (UFLS) scheme installed in the MPS.

This research paper aims to assess the existing UFLS scheme used in the MPS. As the experience demonstrated in the event of 29<sup>th</sup> June 2018, the sudden disconnection of the 220 kV interconnecting transmission lines between Russia and Mongolia produces the largest loss infeed, as a consequence, this major event is used as system frequency disturbance to assess the UFLS used in the MPS. The impact of that major event in the system frequency response of the MPS is evaluated by using time-domain simulations on the whole real power system model simulated using DlgSILENT® PowerFactory™. This paper considers two main scenarios: (i) Winter High and (ii) Summer Low. Winter scenario is characterised by the classical winter peak in the demand of the MPS, and Summer Low has a very low power demand, but this scenario is of the particular interest in this paper because the total system inertia is reduced due to many power stations that are not disconnected from the MPS.

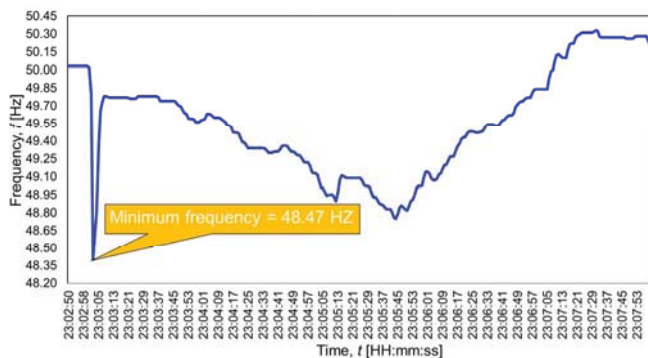

Fig. 2. Frequency plot of the major event of 29<sup>th</sup> June 2018.

The main contribution of this paper is to provide the Transmission System Operator (TSO) of the MPS an assessment of the actual UFLS scheme by using simulations considering the major loss infeed coming from Russia. Simulation results in the summer low inertia scenario indicate the UFLS action may lead to frequency instability in the case of a major event of the Russia-Mongolia interconnection at 250 MW power transfer.

## II. MONGOLIAN POWER SYSTEM

### A. Description of the Mongolian power system

The Mongolia electricity sector is an unbundled system divided into generation, distribution, transmission and dispatching companies. Coal-fired power plants (CFPP) generate approximately 85 per cent of total electricity in the MPS. On the other hand, Renewable Energy Sources (RES) including hydro, wind and solar sources are generated 20 per cent of total electricity. In recent years, many projects to construct renewable energy power plants have been advanced. However, progress has generally been slower than expected [1].

Electricity is supplied through five regional energy system which are Central Energy System (CES), Western Energy System (WES), Altai Uliastai Energy System (AUES), Eastern Energy System (EES) and Southern Energy System (SES). In the whole power system, there are nine thermal power plants, three wind power plants, five solar power plants and three hydropower plants. The power generated by all generation sources is transmitted through 220 and 110 kV overhead

transmission lines [1].

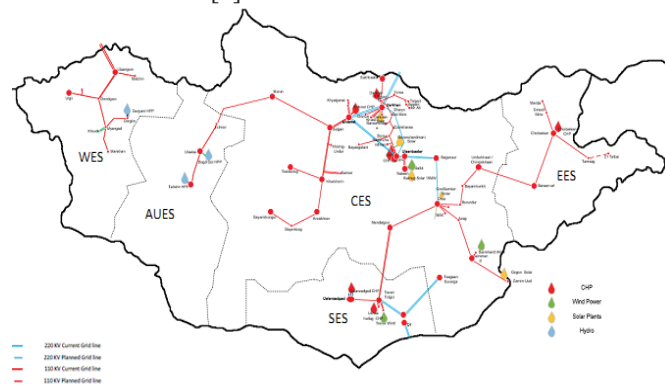

Fig. 3. The illustrative geographical location of main electricity infrastructure and the energy systems in Mongolia.

The CES is the largest energy system in Mongolia with a total installed capacity of 1,281 MW. Combined heat and power plants represent the 63.5 per cent, and RES plants are 16.5 per cent of the total installed capacity. The difference with the peak demand is covered by electricity imported from Russian (about 20 per cent). The CES has some developments on the mining business, Tavan tolgoi coal mine and Oyu tolgoi copper mine in the south Gobi region lead to a larger increase in the demand for electricity [1]. Oyu tolgoi is one of the most significant developments in copper and gold mining, and it is presently supplied by IMPC 220 kV AC from China (max load 300 MW) [1]. In 2019, Oyu tolgoi's peak power demand was estimated at just under 200 MW, and the average load is 149 MW [1]. CES has been connected with the energy storage system (ESS), Altai-Uliastai Energy system and Russian electricity network. Transmission line between EES and Altai-Uliastai energy system is a capacity of 110 kV. WES covers three provinces in the western part of Mongolia with a total demand of 20 MW. EES covers two provinces in the eastern part of Mongolia with a total demand of 36 MW. Double circuit transmission lines between CES and Russian is of 220 kV and also the WES is connected Russian electricity network.

### B. Description of UFLS in Mongolia

The MPS has a classical UFLS scheme, and it is based on an automatic conventional static UFLS, where the under-frequency relay (81) has a set of pre-defined settings [2], [3]. The UFLS scheme is designed to compensate for any power imbalance in the MPS; it is a decentralised scheme that has nine stages based on local measurement at each local placement.

The purpose of the load shedding plan is to arrest the frequency before it reaches 47.0 Hz value, to avoid the intervention of the minimum frequency protection of the generators that intervene at 46.0 Hz. The load shedding plan in the MPS is designed for a maximum shed of about 45-55% of the national grid demand. The UFLS in the MPS works in a range from 48.8 Hz up to 47.2 Hz. There are typically about nine steps (the interval and the number of the steps could vary from one area to another depending on the typical shape of the load, and the network characteristics, discussion of those details are beyond the scope of this paper, see Table I for details). The first stage needs to shed a relatively 8 per cent of loads in order to reduce significantly the rate at which the frequency drops. Once

the rate at which the frequency drops is slowed, then it is allowed to trip 5 per cent of load, this setting also helps to prevent a large over-shoot during the frequency recovery period. 85% of total load installed in the MPS has frequency relays; they are equipped with modern microprocessor-based relays: ABB®, SEL® and Siemens. However, it must be noticed that not all the loads are not equipped with a rate of change of frequency (*ROCOF*) relays (81R) in the existing power system.

TABLE I  
SETTINGS OF THE EXISTING UFLS IN MPS

Stage	Frequency setpoint [Hz]	Time Delay [s]	Load Shedding [%]
1	48.8	0.3	8.0
2	48.6	0.3	5.0
3	48.4	0.3	5.0
4	48.2	0.3	8.0
5	48.0	0.3	8.0
6	47.8	0.3	5.0
7	47.6	0.3	5.0
8	47.4	0.3	5.0
9	47.2	0.3	5.0

### III. METHODOLOGY

This paper is dedicated to assessing the existing UFLS schemes installed in the MPS. The system frequency response of the MPS is analysed using time-domain plots of the system frequency when the major event is applied to the MPS. As the MPS is especially sensitive to disconnection from the Russian grid, this event is used to assess the suitability of the UFLS.

The assessment of the system frequency analysed is used as the main indicator for the evaluation of the UFLS [4]. As the MPS is not equipped with automatic generation controller (AGC), the system frequency is analysed in its more pure and classical primary response (see Fig. 4).

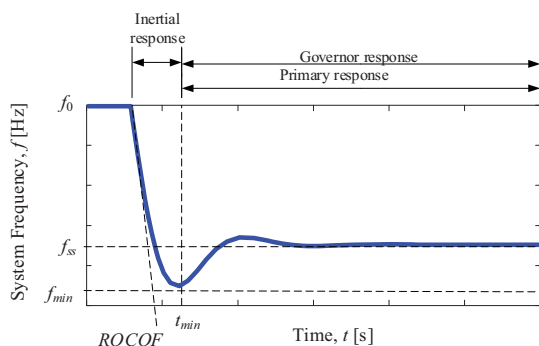

Fig. 4. Classical system frequency response showing the main indicators used in this paper.

The indicators used in the system frequency response are [5], [6], [7], [8]:

- Minimum frequency ( $f_{min}$ ). It refers to the minimum value of the frequency during the transient. It is measured in Hz.
- Minimum time ( $t_{min}$ ). It represents the time required to reach the minimum frequency ( $f_{min}$ ) from the moment where the disturbance is inserted in the power system ( $t = 0$ ). It is measured in seconds.

- Maximum Rate of Change of Frequency (*ROCOF*). The *ROCOF* is calculated as the rate of change of the frequency measured by the frequency relays, and the unit used is Hz/sec.
- Steady-state frequency ( $f_{ss}$ ). The capacity of the power system of recovering from the event is measured by the steady-state frequency; it represents the final value of the frequency when *ROCOF* is zero.

As established during the analysis of the major event on 29<sup>th</sup> June 2018, the MPS is especially vulnerable to disconnection from the Russian power system, as a consequence, this event is considered the most critical infeed load and it is used to test the suitability of the UFLS.

#### A. Scenarios definition

The system frequency response is sensible to two main parameters: (i) the total system inertia ( $H_{sys}$ ) and (ii) total power imbalance ( $\Delta P$ ). The latter one depends on many factors, however, the case of the MPS the important factors are mainly two: the power transfer imported from the Russian power system ( $P_{tie}$ ) the load demand ( $P_{load}$ ) in the MPS. Regarding the power demand, the total peak demand in the MPS has increased in recent time (see Table II), and the maximum power transfer (import/export) from the Russian power system has slightly increased reaching the maximum capacity of 250 MW in 2019.

TABLE II  
PEAK DEMAND GROWTH IN THE LAST FIVE YEARS, CES

Year	2015	2016	2017	2018	2019
Peak load, $P_L$ [MW]	965	975	1,016	1,115	1,153
Max. import power from Russian, $P_{tie}$ [MW]	230	245	245	245	250
Peak growth [%]	0.4%	1.0%	4.2%	9.9%	5.5%

The power demand of the MPS is very dependant of the time of the day, but also season has a massive impact on electricity consumption. Fig 5 shows the 24-hour load profile of the CES during a winter high load period.

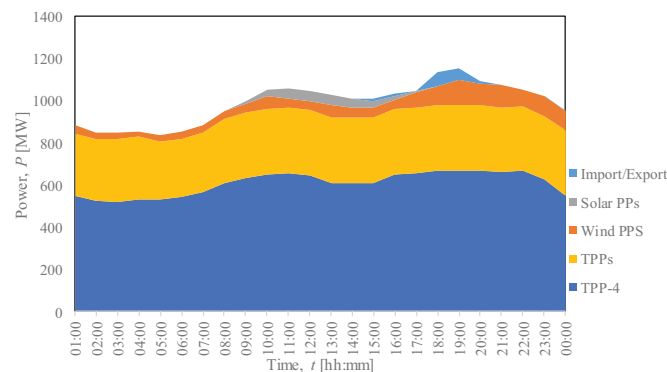

Fig. 5. Daily load profile of the CES during a winter high load period.

The difference between peak load (in the evening) and low night-time load (offload hours) directly depends on the type of consumers and their consumption patterns. During a winter season-high load period, daily electricity demand is about 18.0-23.0 million kWh, and the daily difference between peak and low load is reaching 280-400 MW.

In this research paper, two main scenarios are considered:

*Scenario I:* Winter Peak, High demand, High inertia. The winter season is freezing in Mongolia, reaching temperatures below -35°C, so the peak demand is maximum at that time of the year. This scenario considers the maximum demand ~1,235 MW @ 19:00 hours, as a consequence, the generation at the MPS is at its maximum capacity ~985 MW and the remaining demand is coming from the Russian power system, ~250 MW. In this paper, three cases are considered based on medium and load demand that causes different power flow in the intertie. As the winter peak demand stresses the generation power plants at the MPS and requires a large number of generation unit on service, the total inertia is maximum  $H_{sys} = 5.93$  sec @ peak demand, or total kinetic inertia of  $KE_{sys} = 7319.80$  MW·sec. Peak load forecast of the CES is made based on the load growth of recent years and information of new major end-users to get connected to the grid. CES demand growth in the last five years is shown in Table II. In this paper, peak load is considered 1234.8 MW in MPS.

*Scenario II:* Summer Low, low demand, low inertia. Summer season is quite at the major cities in Mongolia, Mongolian people used to explore the countryside of the country and central heating system is stopped during the summer, as a consequence, the power demand reach is minimum ~ 556 MW @ 03:00 hours, as a consequence, the generation is minimum and the power imported from Russian power system is minimum at 50 MW. As the demand is reduced and also many big power plants are out the service because scheduled maintenance, the total inertia reaches its minimum  $H_{sys} = 3.66$  sec @ summer peak demand, or total kinetic inertia of  $KE_{sys} = 2402.4$  MW·sec.

There is a clear difference between those scenarios, the inertia is reduced in a significant amount, from the KE is easy to see there is a reduction of 67.1794%. Therefore, it is clear that Scenario II is more challenging in terms of frequency control as the minimum inertia produces faster and deeper changes in the system frequency. Finally, the ULFS is assessed in the aforementioned two scenarios based on power demand/importation and system inertia.

#### B. Cases Definition

The system frequency response is influenced by the size of the power imbalance, as demonstrated during the major event of 29<sup>th</sup> June 2018. The sudden disconnection of the 220 kV interconnectors to the Russian system creates the most significant infeed loss; as a consequence, this paper uses this event as system frequency disturbance to assess the ULFS. The size of the power imbalance depends on the power flow transferred by the interconnection from Russia to Mongolia, in this paper three cases are considered: *Case 1:* Low importation,  $P_{tie} = 50$  MW, *Case 2:* Average importation,  $P_{tie} = 150$  MW and *Case 3:* Maximum importation,  $P_{tie} = 250$  MW.

TABLE III  
SCENARIO I: WINTER PEAK OPERATION SCENARIO, HIGH INERTIA

Case	Operation time of day	Total demand $P_L$ [MW]	Generation $P_{gen}$ [MW]	Import power from the Russian $P_{tie}$ [MW]
1	03:00	838.0	788.5	50.00
2	12:00	1094.8	944.8	150.0
3	19:00	1234.8	984.8	250.0

A summary of the main indicators of the Scenarios and Cases are shown in Table III and IV. Due to daily demand difference between peak and low demand is reaching 30-40%, six different loading conditions are considered based on the combination of Scenarios and Cases: (I.3) Winter peak, (I.2) winter medium, (I.1) winter low, (II.3) summer peak, (II.2) summer medium and (II.1) summer low.

TABLE IV  
SCENARIO II: SUMMER LOW OPERATION SCENARIO, LOW INERTIA

Case	Operation time of day	Total demand $P_L$ [MW]	Generation $P_{gen}$ [MW]	Import power from the Russian $P_{tie}$ [MW]
1	03:00	556.0	506.0	50.00
2	12:00	656.0	506.0	150.0
3	19:00	585.0	335.0	250.0

#### IV. SIMULATION AND RESULTS

The full dynamic model of MPS has been implemented in DigSILENT® PowerFactory™ to investigate the performance of the existing UFLS scheme in the MPS. The MPS models implemented in PowerFactory™ consists of 61 synchronous generators, three wind power plants, five PV power plants, 7685 terminals, 236 lines, 260 loads distributed in the power system (see Fig 6).

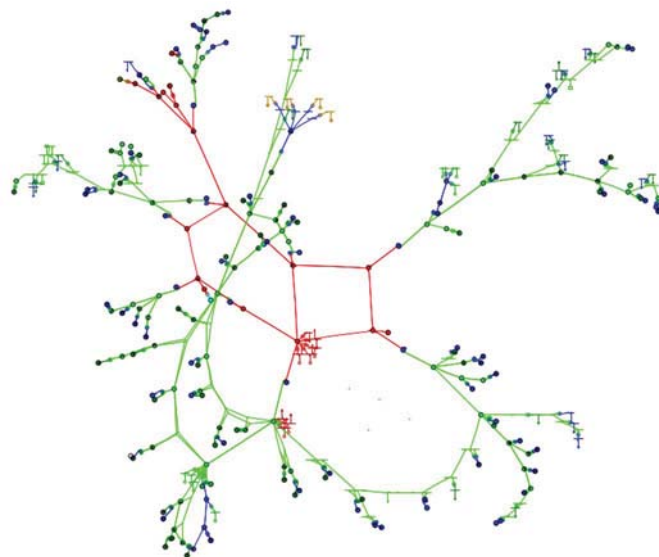

Fig. 6. Graph representing the MPS, specifically to the CES. More details are not included because of confidentiality reasons.

The MPS model included all models required to perform dynamic analysis of electromechanical transients such as governors and automatic voltage regulators (AVR). Moreover, the protection schemes of the MPS consist of 85 UFLS relays, each relay has nine stages, and the settings have been defined based in the MPS specification. Settings of the UFLS has been verified with the specialised personnel at the field. The model of UFLS is represented as their block diagram, as shown in Fig. 7.

The sudden disconnection of the 220 kV interconnectors to the Russian system creates the most significant infeed loss; as a consequence, this paper uses this event as system frequency

disturbance to assess the UFLS. Therefore, the disturbance is simulated by the sudden disconnection of the main interconnection 257 and 258 lines at  $t = 0$  sec; it is done by tripping by main protection. Fig. 8 present a simplified single-line diagram of the MPS, specifically the CES where the interconnectors are highlighted.

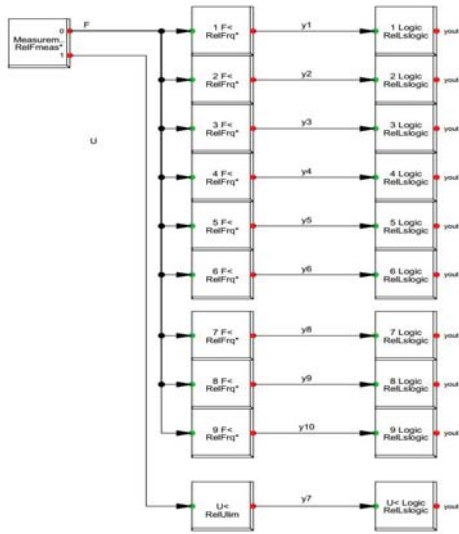

Fig. 7. Under-frequency load shedding relay used in the MPS model. The under-voltage sub-relay is not active in any simulation case in this paper.

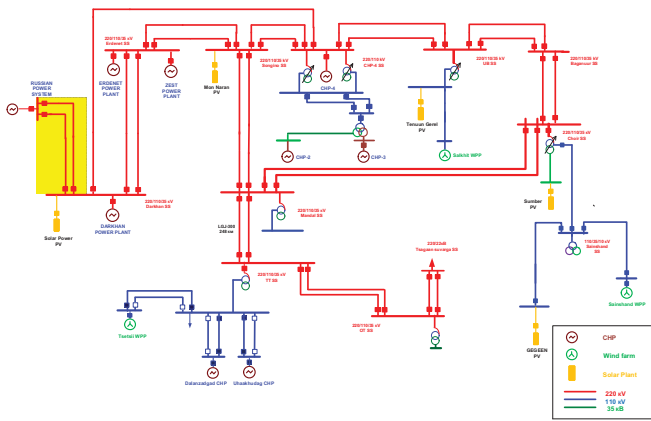

Fig. 8. Simplified single-line diagram of the MPS presenting major components and the interconnector to the Russian power system.

The basis for the existing settings is that the power system should be able to continue operation following a total loss of power up to  $P_{tie} = 250$  MW. This represents the simultaneous tripping of the main interconnection 257 and 258 lines between the Russian and MPS were disconnected. DIGSILENT® PowerFactory™ is used to simulate the MPS on the considered scenarios and cases. For each simulation, synchronous machines minimum ( $f_{min}$ ) and steady-state frequency ( $f_{ss}$ ),  $ROCOF$  and bus frequencies of loads (Measurement *RelFmeans* in the PowerFactory™ model of UFLS) were measured over the simulated duration of 100 seconds. It is essential to mention that the main power plants governor droop settings were tuned by a test of results on the real system.

### A. Results and Discussions

The response to the loss of 50,150 and 250 MW was simulated to assess the existing UFLS scheme for the six previously defined loading conditions. The power system peak demand is 1234.8 MW in January, and the maximum import power is 250 MW in the winter peak operation scenario that is the worst case in a real system for frequency stability. The event is applied the main interconnection 257 and 258 lines tripped by primary protection. In this case, the 257 and 258 lines were disconnected after a delay of around 3.15 seconds the system frequency is dropped to minimum value 48.25 Hz and maximum  $ROCOF$  is  $-0.97$  Hz/s. The UFLS 1<sup>st</sup> stage is started 48.8 Hz, shedding 90.2 MW, 2<sup>nd</sup> stage is started 48.6 Hz, shedding 43.7 MW and 3<sup>rd</sup> stage is started 48.4 Hz, shedding 40.3 MW then the frequency is reached to 48.83 Hz. However, that value is insufficiently recovered for acceptable value as well as, in the Mongolian grid code is required the normal operating range is  $50 \pm 0.1$  Hz, the frequency deviations of  $\pm 0.2$  Hz are allowed for 10 minutes [9]. The minimum frequency is not reached to 4<sup>th</sup> stage set due to the frequency is recovered from 48.25 Hz. (see Fig. 9 and 10, Table V).

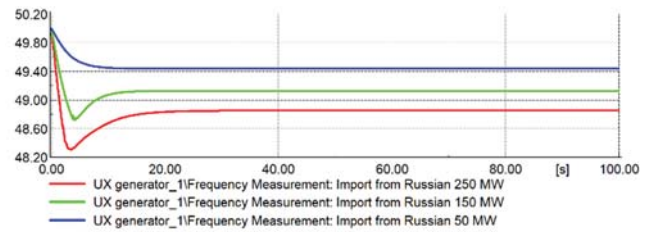

Fig. 9. Frequency response for winter peak operation scenario. Scenario I, Case 3.

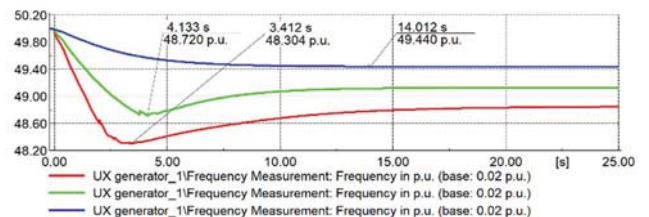

Fig. 10. Frequency response for winter peak operation scenario: Scenario I, Case 1.

TABLE V  
SCENARIO I: UFLS MAIN INDICATOR ASSESSED

Case	Max. $ROCOF$ [Hz/s]	Min. frequency $f_{min}$ [Hz]	Min. time $t_{min}$ [s]	Actions stages	Total shed load $P_{shed}$ [MW]	Steady-state frequency $f_{ss}$ [Hz]
1	-0.20	49.44	14.0	-	0.0	49.44
2	-0.59	48.72	4.13	1	90.2	49.14
3	-0.97	48.30	3.41	1, 2, 3	174.2	48.83

In the summer low operation scenario, the total demand is reached to approximately 550-650 MW. At this time, it should be done maintenance in the big thermal power plants due to facilities ageing. Therefore, system inertia is significantly reduced, and the maximum  $ROCOF$  is  $-1.33$  Hz/s that is a large number in the summer low scenario. These maximum  $ROCOF$

values are represented that MPS has low inertia, especially in the summer low operation scenario.

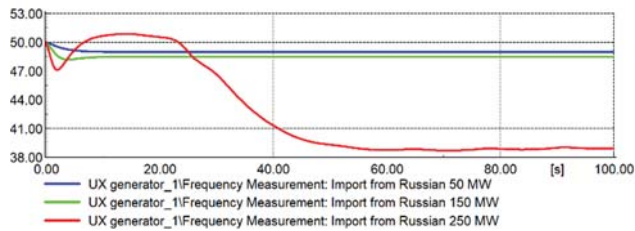

Fig. 11. Frequency response for summer low operation scenario. *Scenario II, Case 3.*

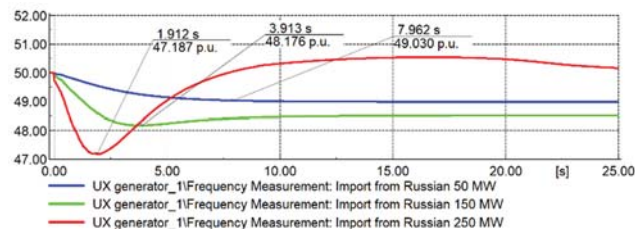

Fig. 12. Minimum frequency response for summer low operation scenario. *Scenario II, Case 1.*

TABLE VI  
SCENARIO II: UFLS MAIN INDICATOR ASSESSED

Case	Max. ROCOF [Hz/s]	Min. frequency $f_{min}$ [Hz]	Min. time $t_{min}$ [s]	Actions stages	Total shed load $P_{shed}^{[MW]}$	Steady-state frequency $f_{ss}$ [Hz]
1	-0.42	48.99	12.41	-	0	48.99
2	-1.33	48.19	3.66	1,2,3	114.7	48.51
3	-3.48	47.09	1.90	All stage	315.9	Unstable

The existing UFLS scheme should be designed and tested again under all worst cases. It is noted that the tripping of load leads to a reduction in both the active and reactive power demand. Consequently, the voltages tend to rise as a consequence of UFLS. In summer low and summer medium operation scenario cases the voltages increase to unacceptable levels. It is recommended that more equipment be switched on SVC and shunt reactor based on bus voltage during the summer scenario.

## V. CONCLUSION

This paper has assessed a review of the existing UFLS schemes for isolated MPS where is particularly sensitive to power imbalances and UFLS schemes are vital to prevent frequency collapse. The existing UFLS scheme could be shed lack power in winter peak and low summer case because UFLS schemes have been on the designed approaches, conventional schemes principally decentralised schemes, based on local measurement and decisions. Another key factor, RES has an

impact on the inertia of the system, which in trend impacts the capability of ROCOF and UFLS to power system outage loss of interconnection lines. The Mongolian grid has already met 20% of the power of RES by 2020 will have a significant impact on the ROCOF and operation of UFLS. Therefore, UFLS scheme has to repeat designed WAMS-based accuracy real data. Because 29 PMU are already installed at crucial points in Mongolian grid on January in 2020. As a result, the frequency behaviour can be measured more accurately in each important bus as well as, the dynamic model of DIgSILENT® PowerFactory™ can be improved by based on full real data. Finally, an optimal UFLS study can be carried out to propose a new effective setting for the existing UFLS scheme and overcome the worst scenario (low inertia and maximum power transfer from Russian grid) if a disconnection from the Russian network occurs.

## ACKNOWLEDGEMENT

Ms Martha N. Acosta wants to acknowledge the financial support given by CONACYT (México) and the support of Universidad Autónoma de Nuevo León. Mr Choidorj Adiyabazar, wants to acknowledge the financial support given by National Dispatching Center of Mongolia Co., Ltd. Ms Martha N. Acosta and Choidorj Adiyabazar would like to recognise the support of the University of South-Eastern Norway. Prof F. Gonzalez-Longatt would like to express his gratitude to DIgSILENT GmbH for supporting his research.

## REFERENCES

- [1] S. Profileprojections, C. Generation, R. Energy, and C. Expansion, "Strategy for NAPS Technical Assistance for Mongolia - RENEWABLE ENERGY CAPACITY EXPANSION PLAN," no. MARCH, 2018.
- [2] H. Bevrani, *Robust Power System Frequency Control*, Second Edi. Cham: Springer International Publishing, 2014.
- [3] F. Gonzalez-Longatt, "Impact of synthetic inertia from wind power on the protection/control schemes of future power systems: Simulation study," in *IET Conference Publications*, 2012, vol. 2012, no. 593 CP.
- [4] F. Sanchez, J. Cayenne, F. Gonzalez-Longatt, and J. L. Rueda, "Controller to enable the enhanced frequency response services from a multi-electrical energy storage system," *IET Gener. Transm. Distrib.*, vol. 13, no. 2, pp. 258–265, Jan. 2019.
- [5] H. R. Chamorro, A. C. Sanchez, A. Pantoja, I. Zelinka, F. Gonzalez-Longatt, and V. K. Sood, "A network control system for hydro plants to counteract the non-synchronous generation integration," *Int. J. Electr. Power Energy Syst.*, vol. 105, pp. 404–419, Feb. 2019.
- [6] F. Gonzalez-Longatt, F. Sanchez, and Rujiroj Leelaruij, "Unveiling the Character of the Frequency in Power Systems," in *IEEE-PES GTD Grand International Conference & Exposition Asia 2019 (IEEE-PES GTD Asia 2019)*, 2019.
- [7] F. Gonzalez-Longatt, J. L. Rueda, and D. Bogdanov, "Assessment of the critical clearing time in low rotational inertia power systems," in *2018 20th International Symposium on Electrical Apparatus and Technologies, SIELA 2018 - Proceedings*, 2018, no. 1, pp. 1–4.
- [8] F. Gonzalez-Longatt, "Effects of Fast Acting Power Controller of BESS in the System Frequency Response of a Multi-Machine System: Probabilistic Approach," in *IEEE ISGT Asia 2018*, 2018.
- [9] National Dispatching Center on Mongolia, "Grid Code," pp. 1–349, 2019.