



Phone House

KJE



TE HUUR
HULSHOF
MAKELAARS
070-381.71.81
WWW.HULSHOF.NL

SPACE FOR LEISURE

experiencing Dutch inner city shopping areas



FASCINATION





FASCINATION



FASCINATION



EXPERIENCE



PROBLEM



PROBLEM



PROBLEM



PROBLEM



PROBLEM



PROBLEM





RESEARCH

RESEARCH QUESTION

**WHICH SPATIAL ASPECTS OF DUTCH INNER CITY SHOPPING AREAS
INFLUENCE THE SHOPPING/LEISURE EXPERIENCE?**

EXPERIENCE & BEHAVIOR

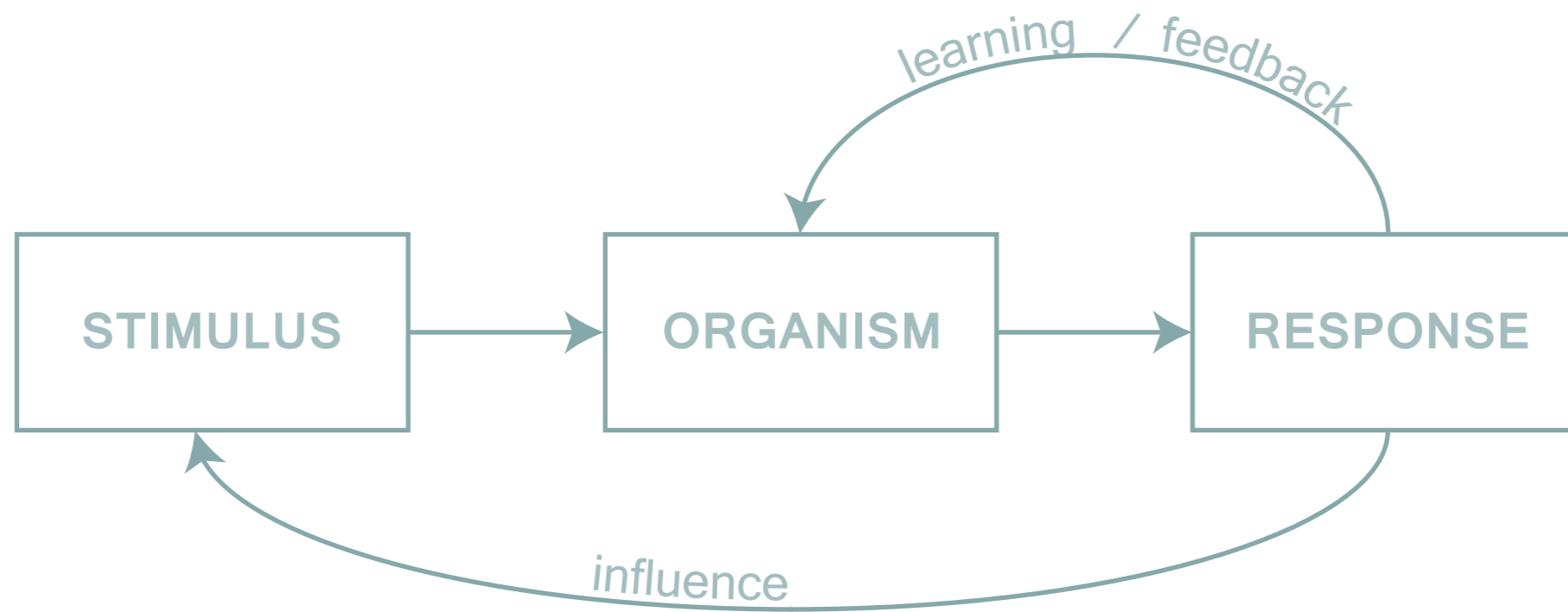

EXPERIENCE & BEHAVIOR

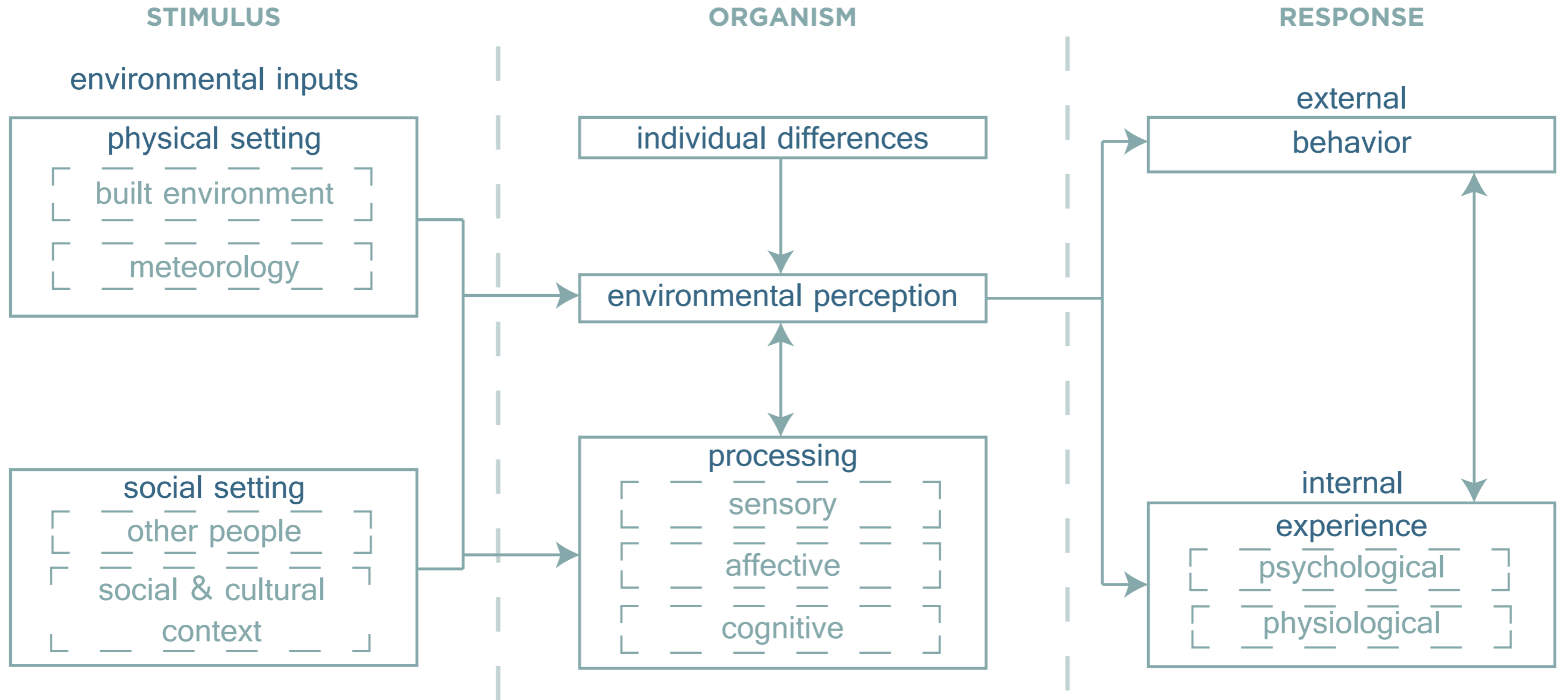

SPACE & BEHAVIOR

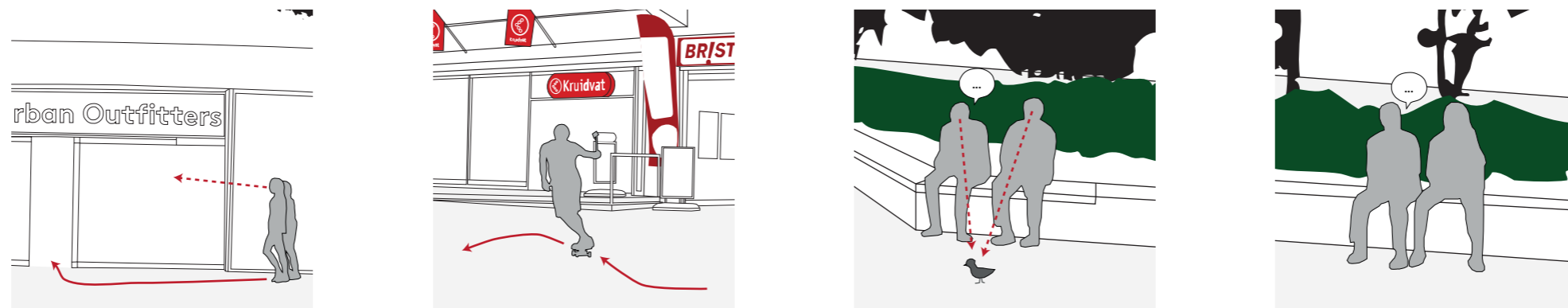
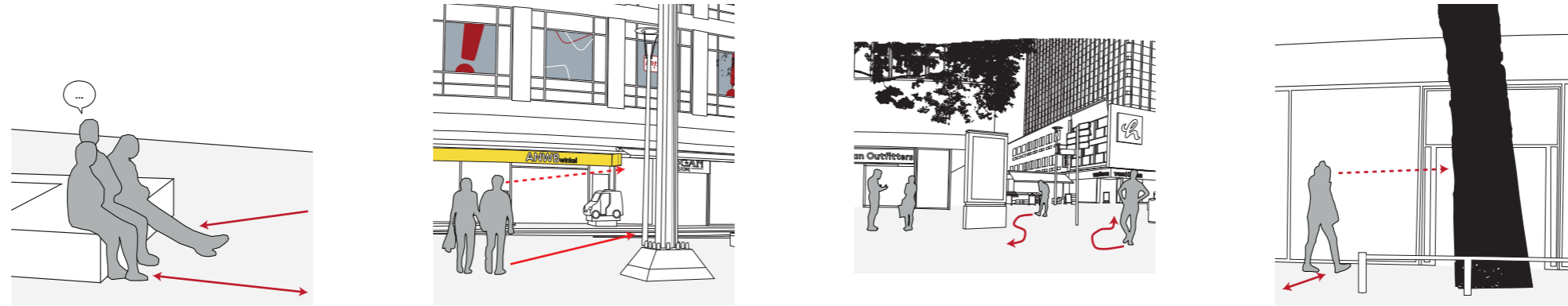

INTRODUCTION

RESEARCH

DESIGN

SPACE & EXPERIENCE

FACADE

openness

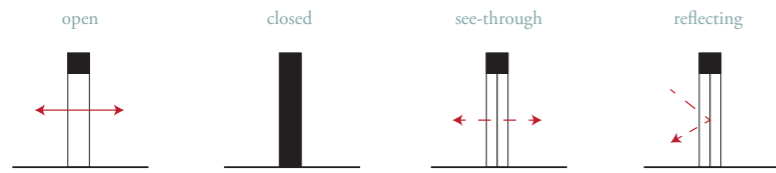

behind facade



signage

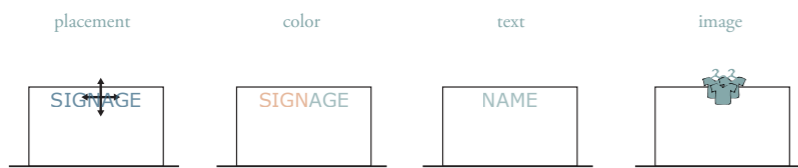

form

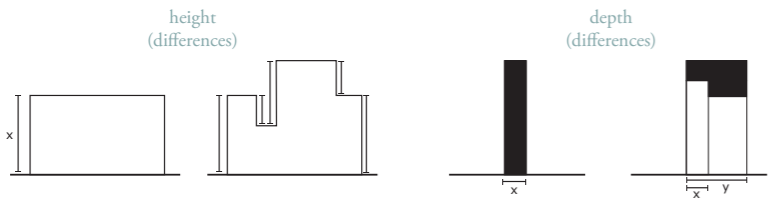

materialization & color



INTRODUCTION

SPACE

spatiality

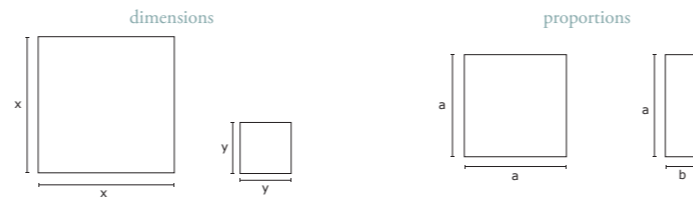

materialization & color

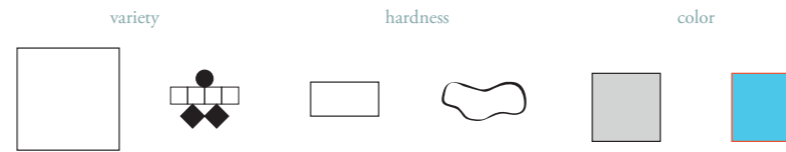

boundaries

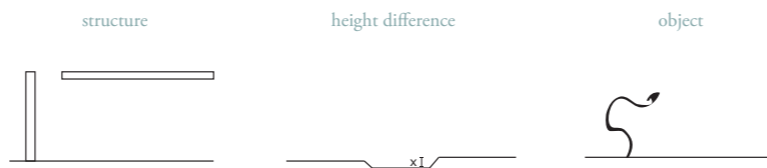

function



RESEARCH

OBJECTS

spatiality

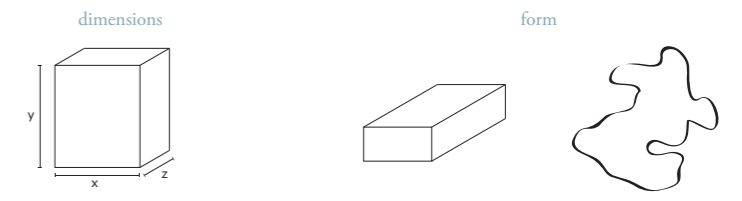

materialization & color

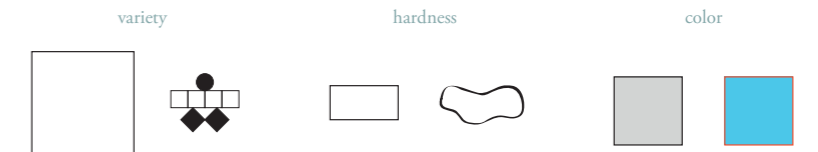

function



placement

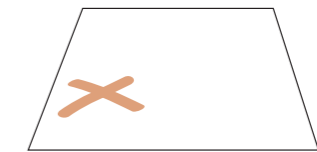

adaptability



DESIGN



mEET

Delft



4,54%



4,54%
102.260



A vibrant street scene in a Dutch town square. On the left, a tall, ornate Gothic church with a prominent spire and a clock face. The square is paved and filled with people, many of whom are riding bicycles. In the background, there are traditional Dutch buildings with red-tiled roofs and gabled facades. The sky is bright blue with scattered white clouds. The text '4,54%' is at the top, '102.260' is below it, and 'locals', 'students', and 'tourists' are stacked vertically in the center-right.

4,54%
102.260
locals
students
tourists

DELFT



DELFT CITY CENTER



DELFT CITY CENTER



DIFFERENT CHARACTERS

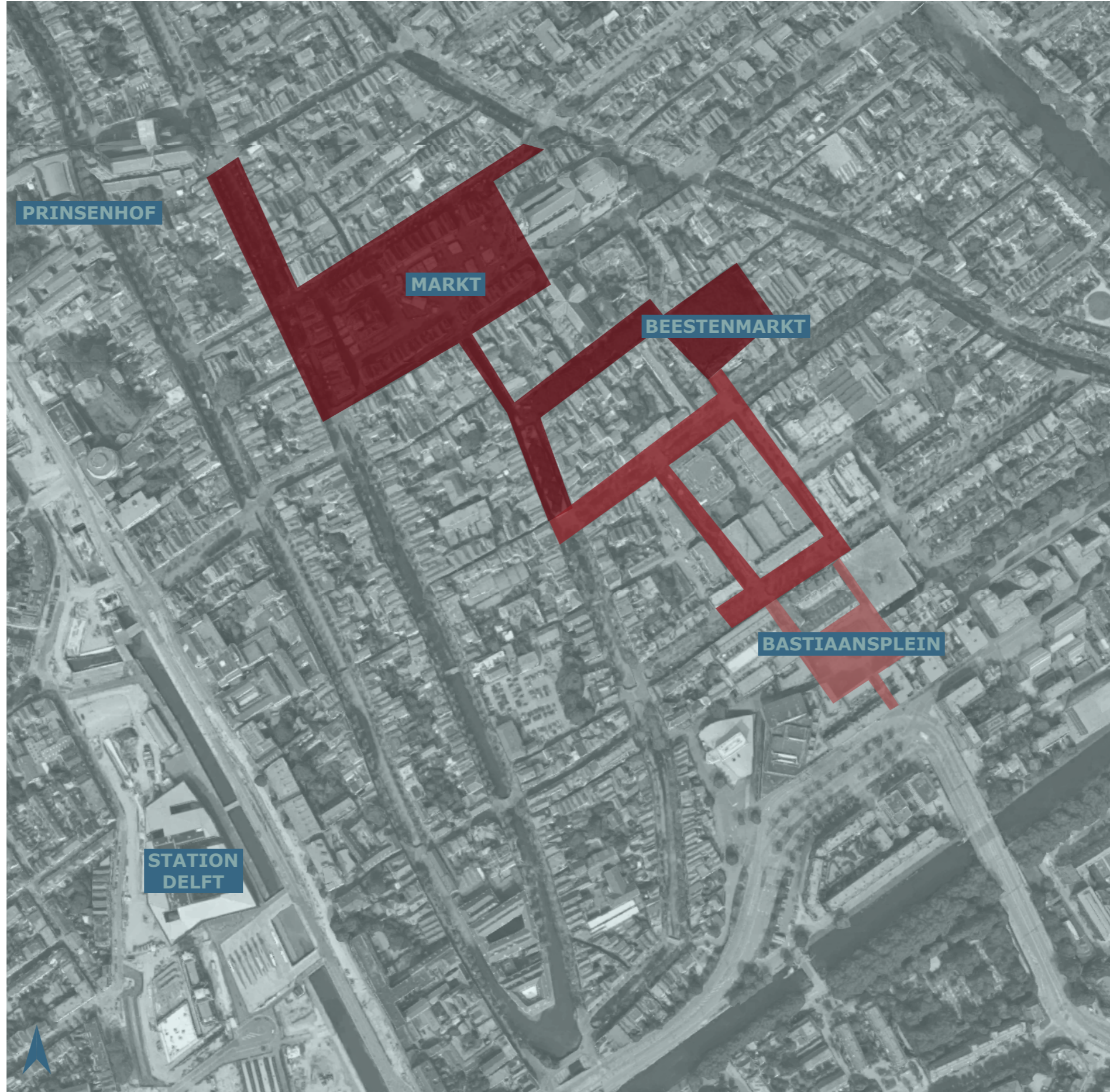

MARKT

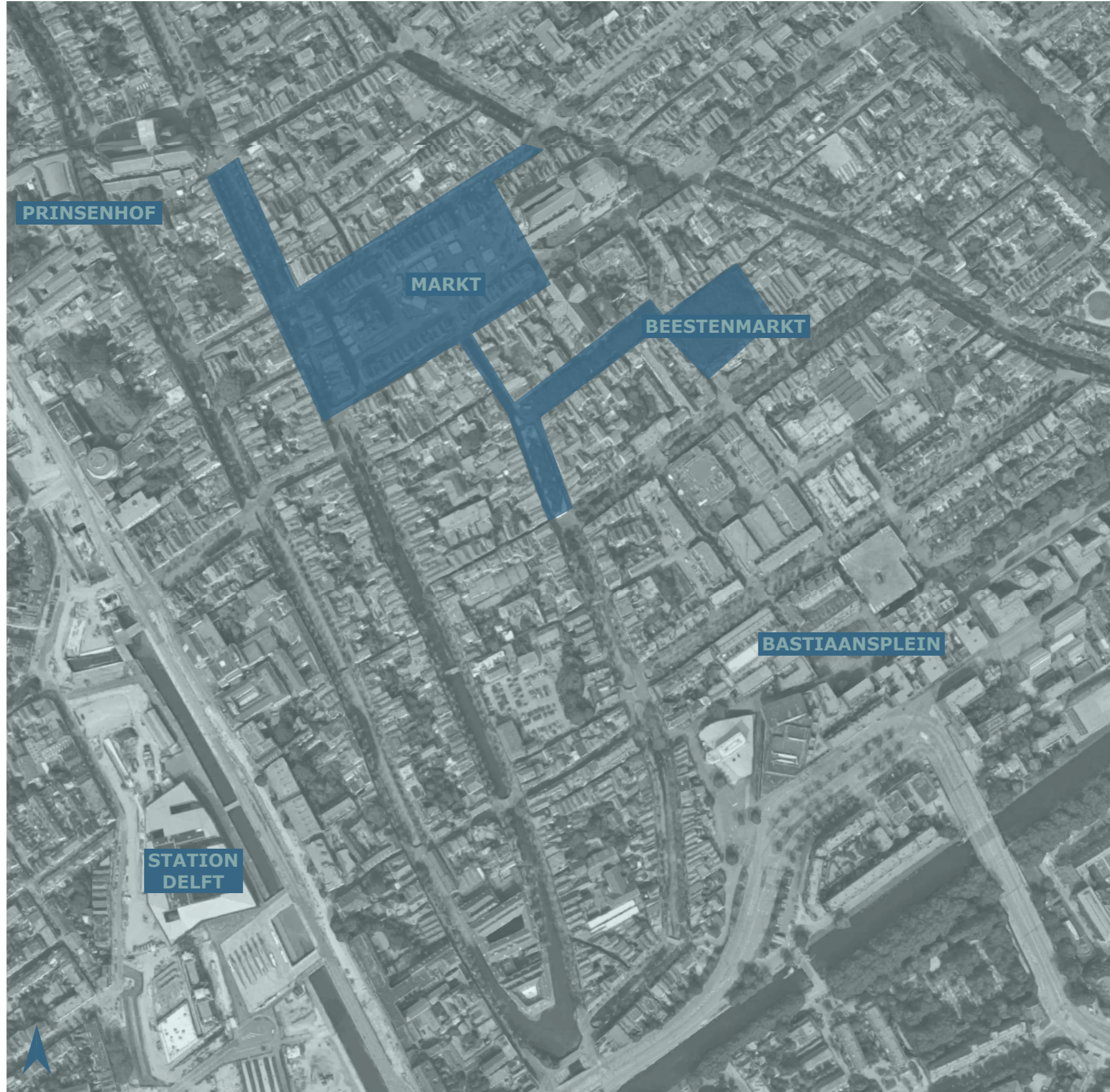

MARKT



BASTIAANSPLEIN



BASTIAANSPLEIN



BETWEEN AREA

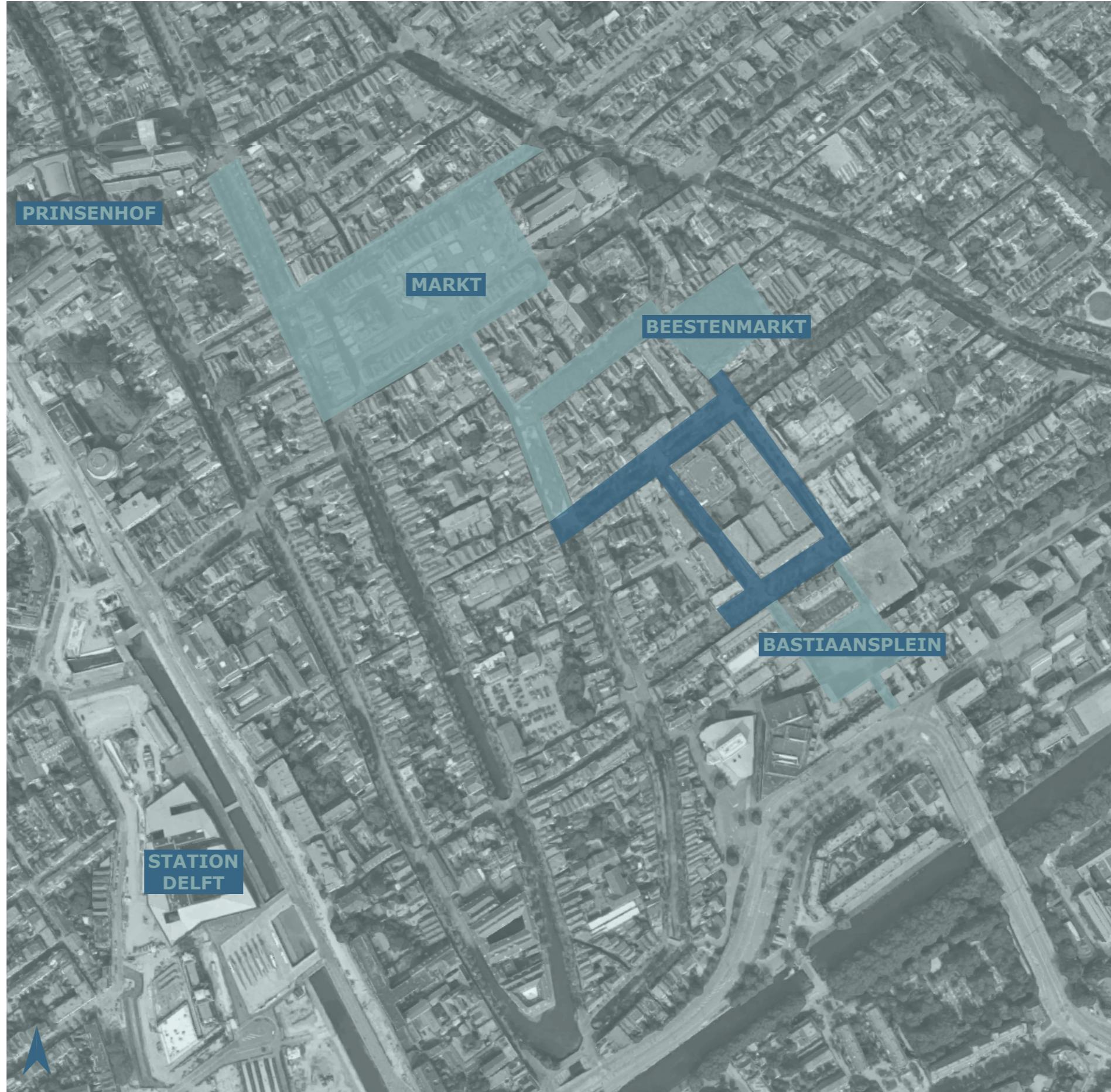

BETWEEN AREA



SITE



SITE



SITE: KRUISSTRAAT 71



CONTEXT



HISTORY

DOK LIBRARY - DEMOLISHED IN 2010



BEWEEGTUIN - DEMOLISHED IN 2013



FUTURE?

LIDL

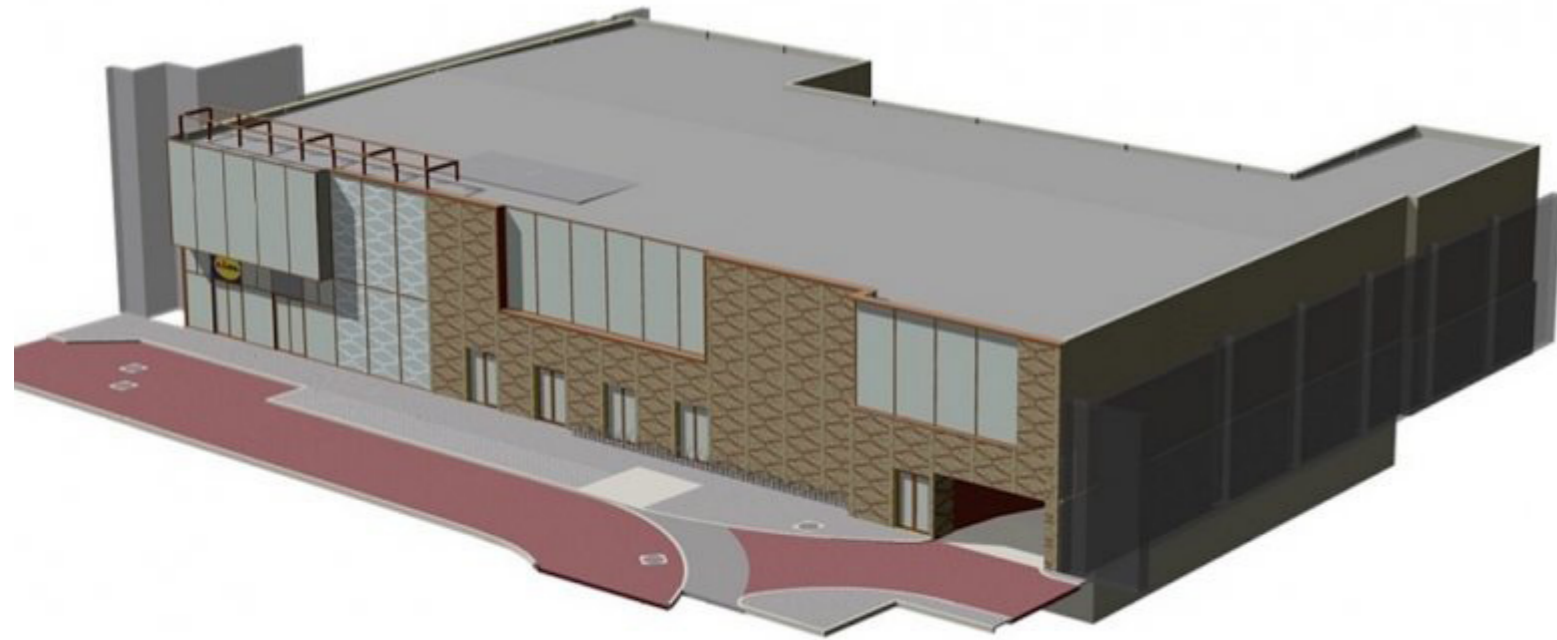

RETAIL & DWELLINGS

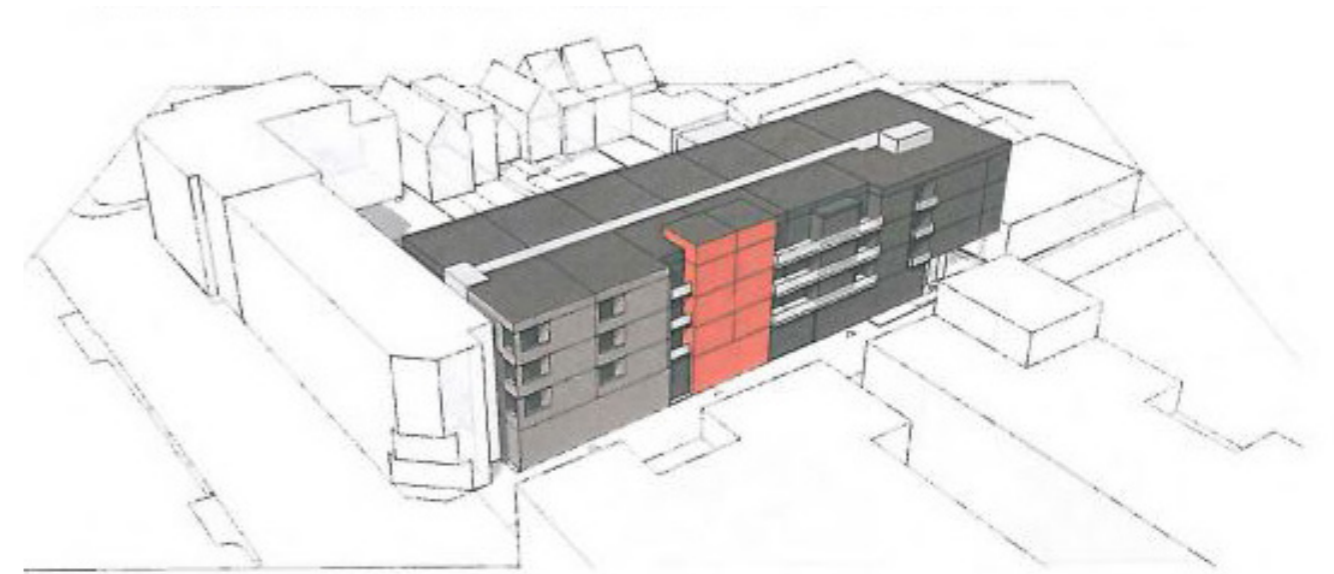

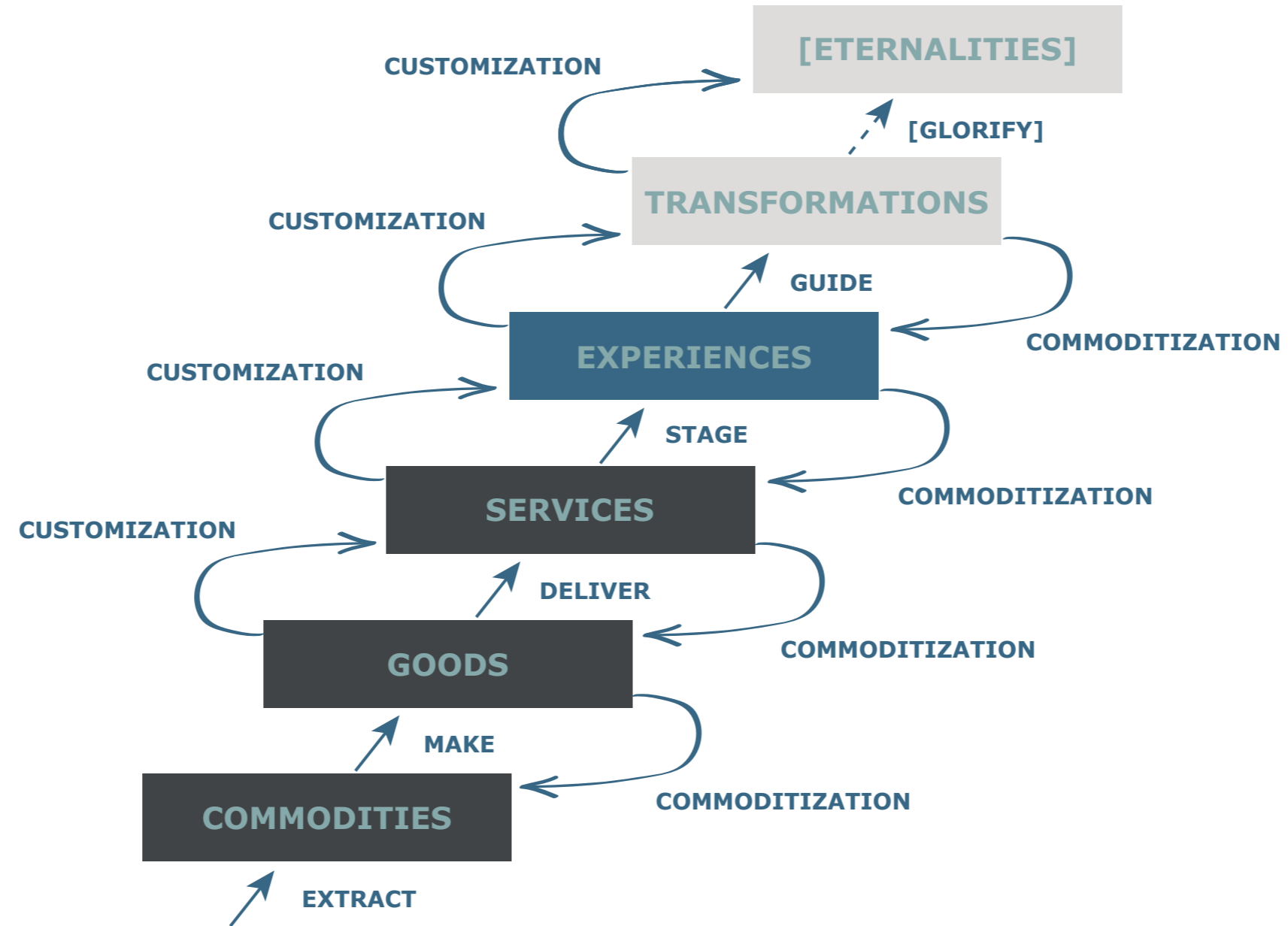



Let's

mEET



DESIGN BRIEF



FOODHALL?

EXPERIENCE

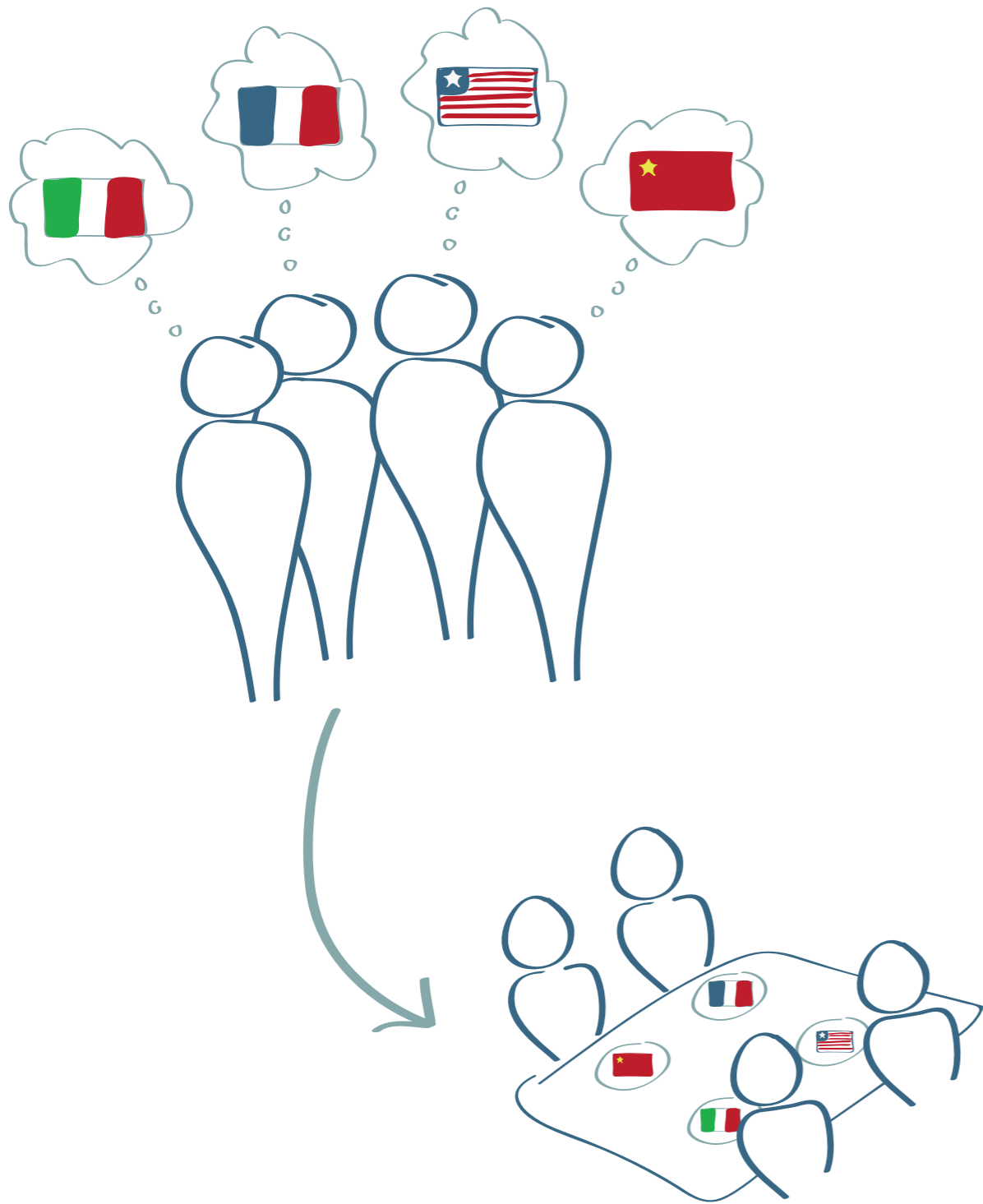

INTRODUCTION

RESEARCH

DESIGN

FOODHALL?

EXPERIENCE

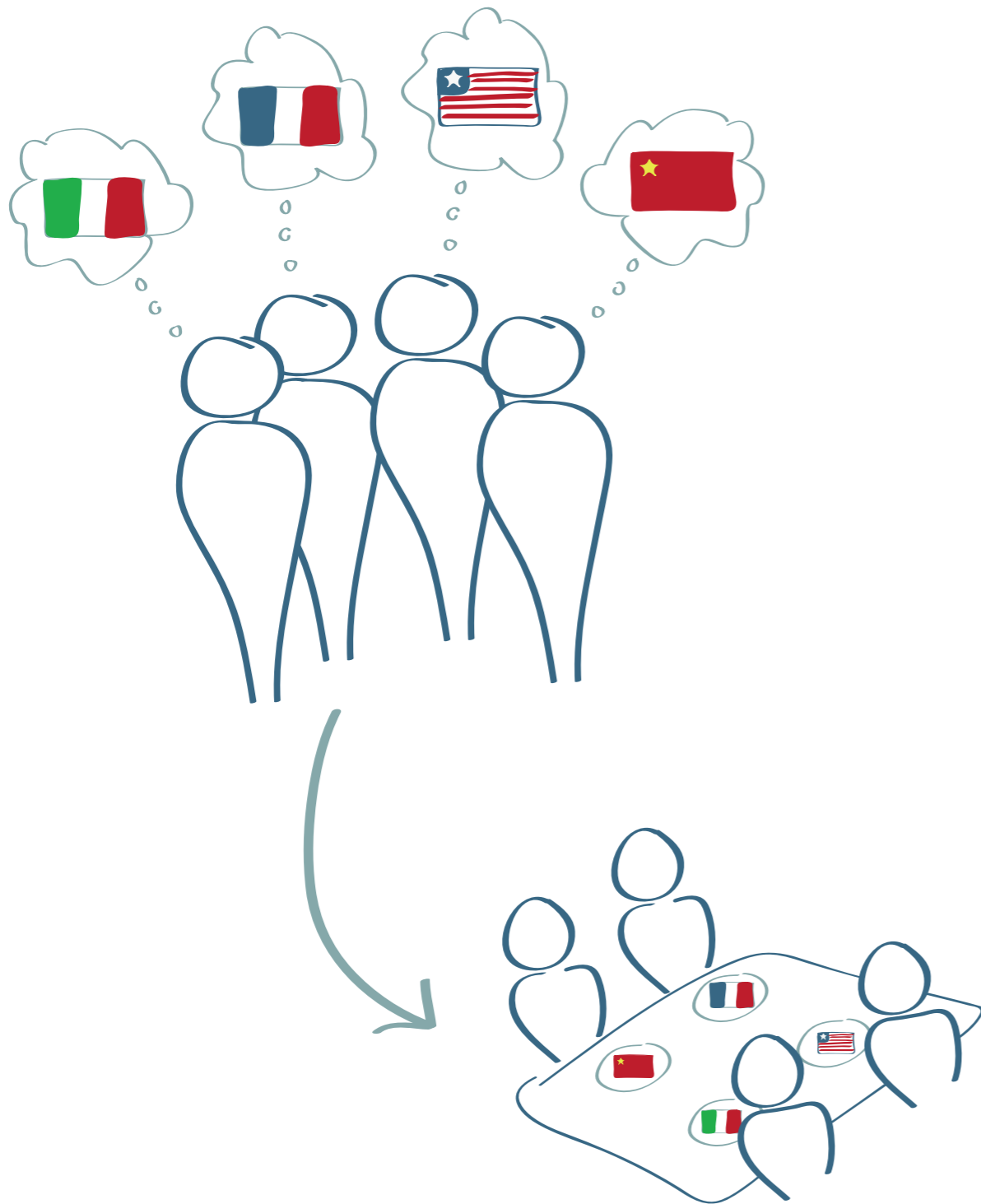

INTRODUCTION

BUSINESS

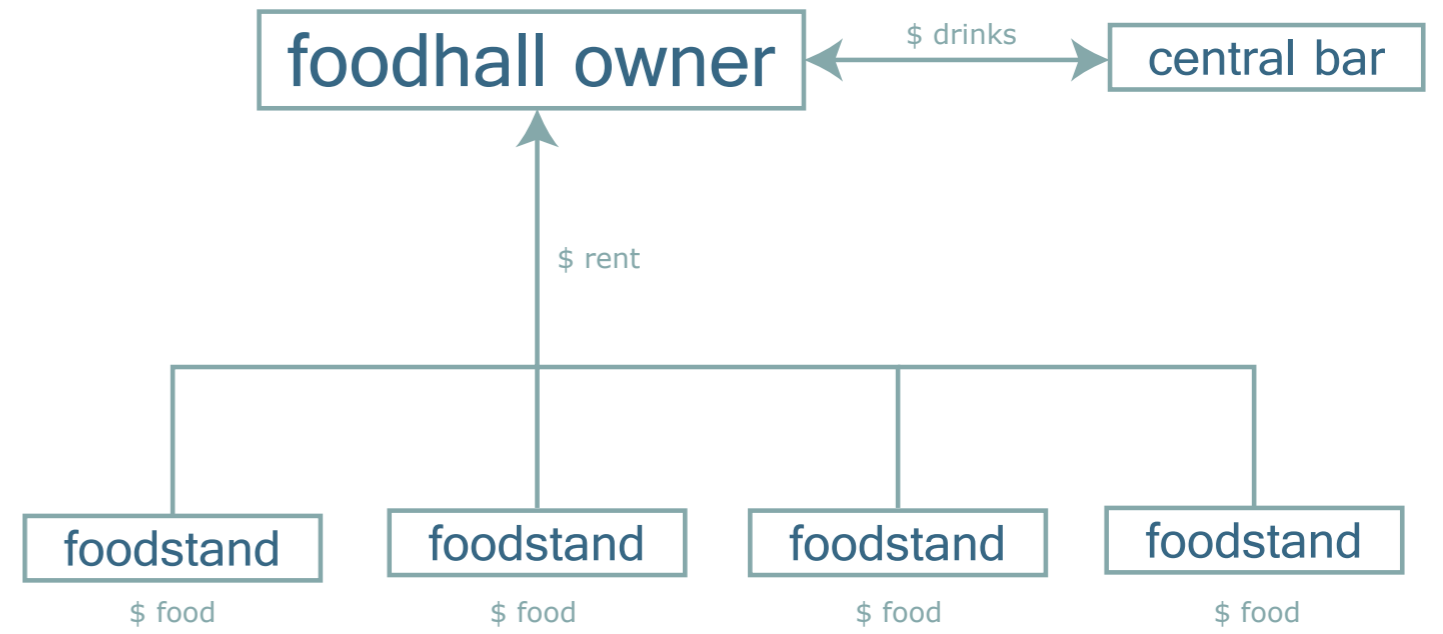

RESEARCH

DESIGN

ADDITIONAL PROGRAM

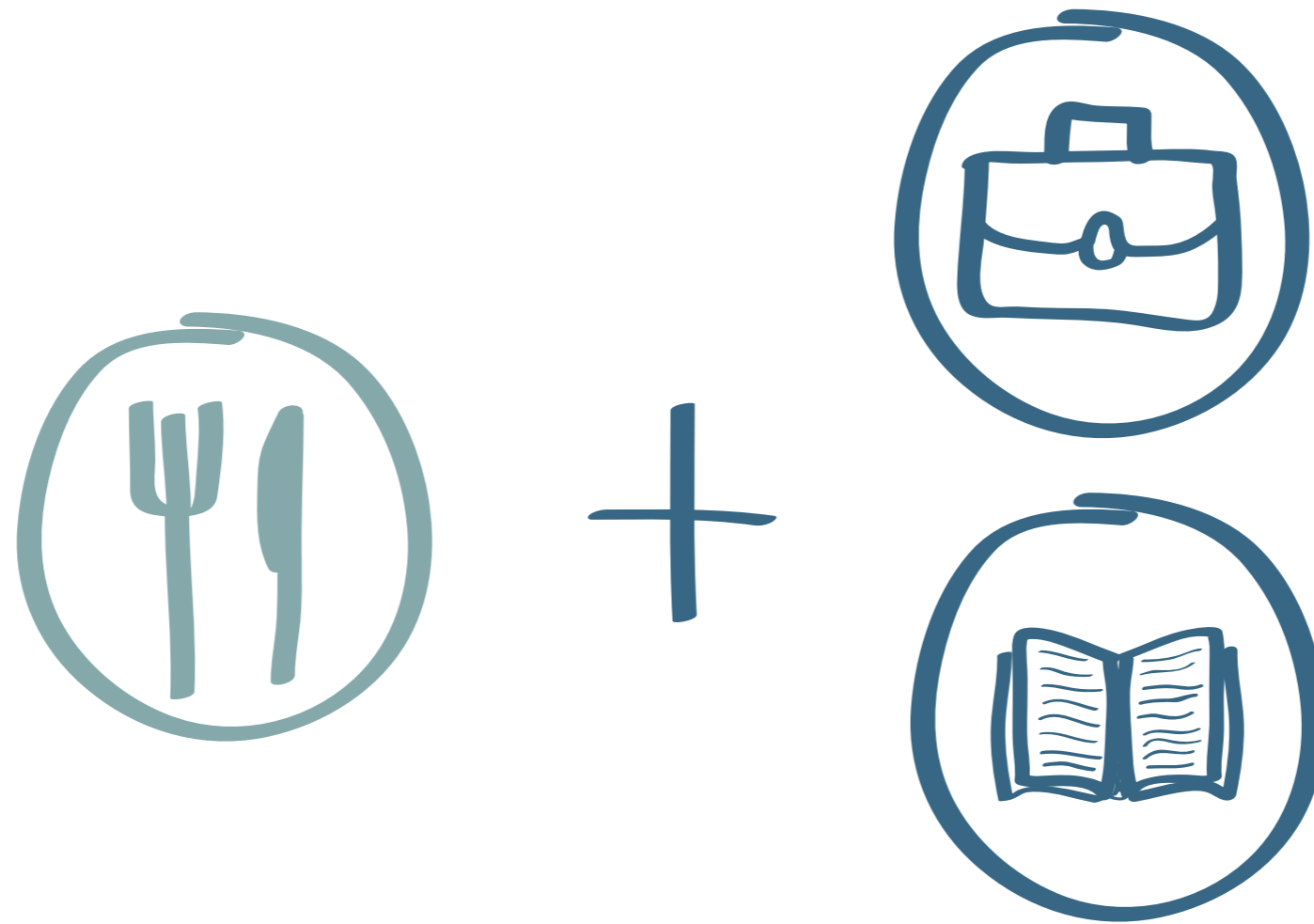

CONCEPT

CONSCIOUS CONSUMPTION

CONCEPT



CONSCIOUS CONSUMPTION

CONCEPT



CONSCIOUS CONSUMPTION

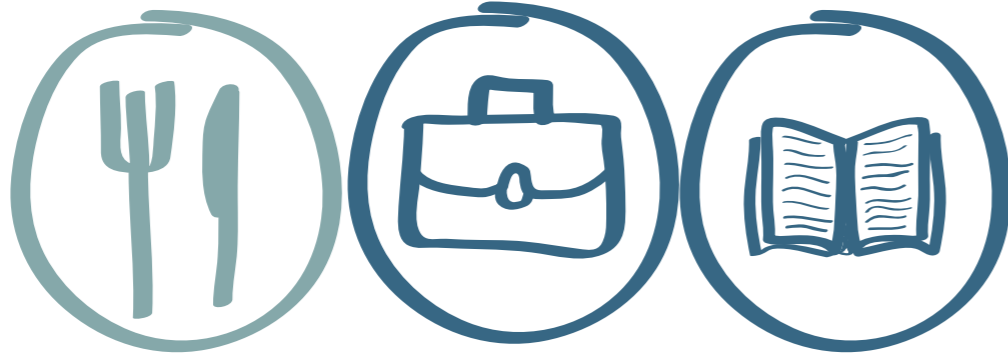

CONSCIOUS CONSUMPTION: USE

CURRENT USE



FOODSTANDS

SEATING

RINSING KITCHEN



INDIVIDUAL AND
COLLABORATIVE
WORKSPACES

MEETING ROOMS

CONSCIOUS CONSUMPTION: USE

CURRENT USE

FUTURE USE

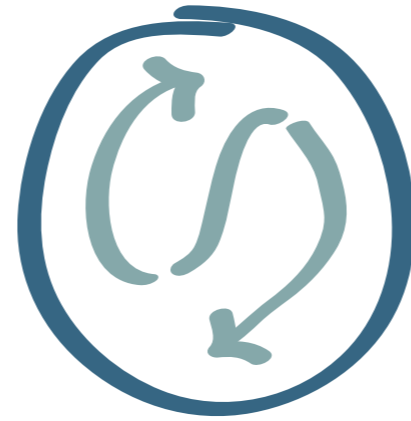

FOODSTANDS

SEATING

RINSING KITCHEN

INDIVIDUAL AND
COLLABORATIVE
WORKSPACES

MEETING ROOMS

FLEXIBILITY

CONSCIOUS CONSUMPTION: USE

CURRENT USE



FOODSTANDS

SEATING

RINSING KITCHEN



INDIVIDUAL AND
COLLABORATIVE
WORKSPACES

MEETING ROOMS

FUTURE USE

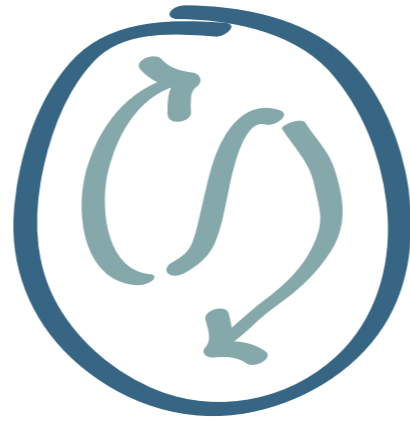

FLEXIBILITY

AFTER USE



DEMOUNTABILITY

INTRODUCTION

RESEARCH

DESIGN

CONSCIOUS CONSUMPTION IN ARCHITECTURE

MATERIAL CHOICE



WAY OF BUILDING

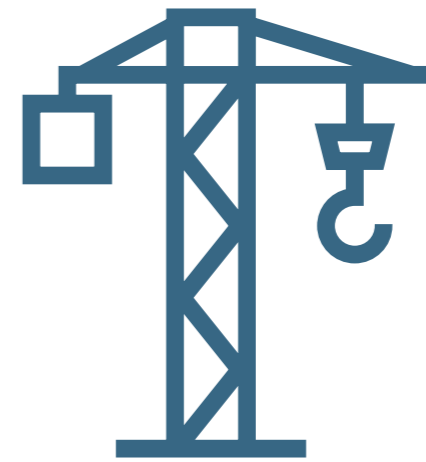

CURRENT USE

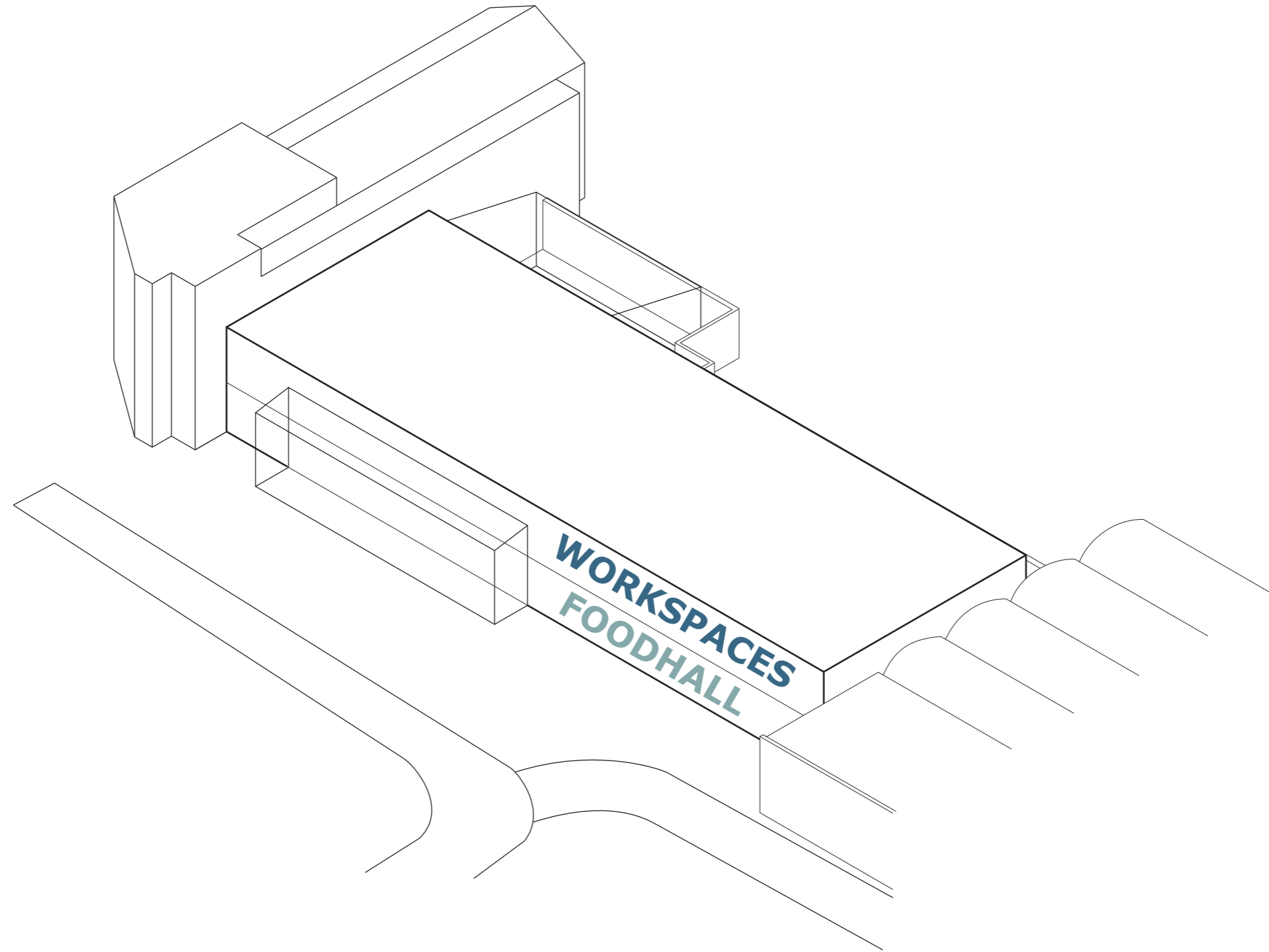

SPATIAL ELEMENTS & EXPERIENCE

FACADE

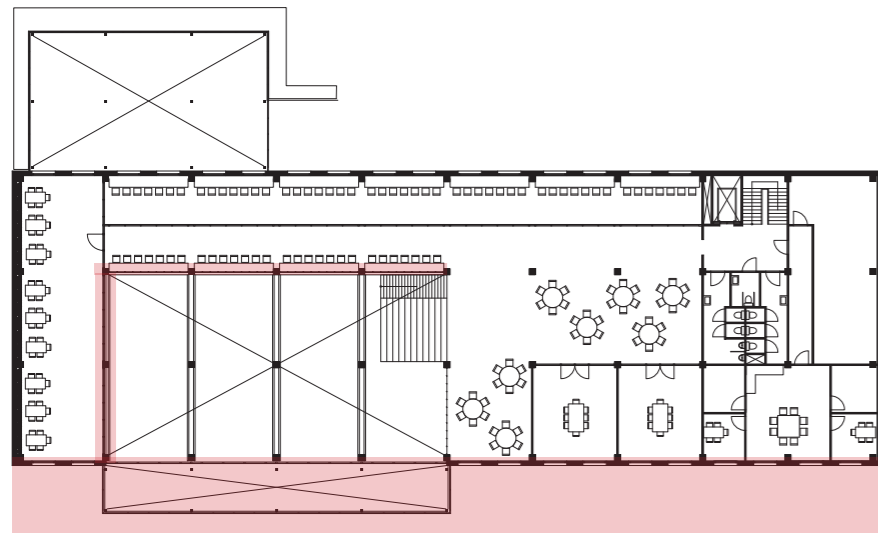
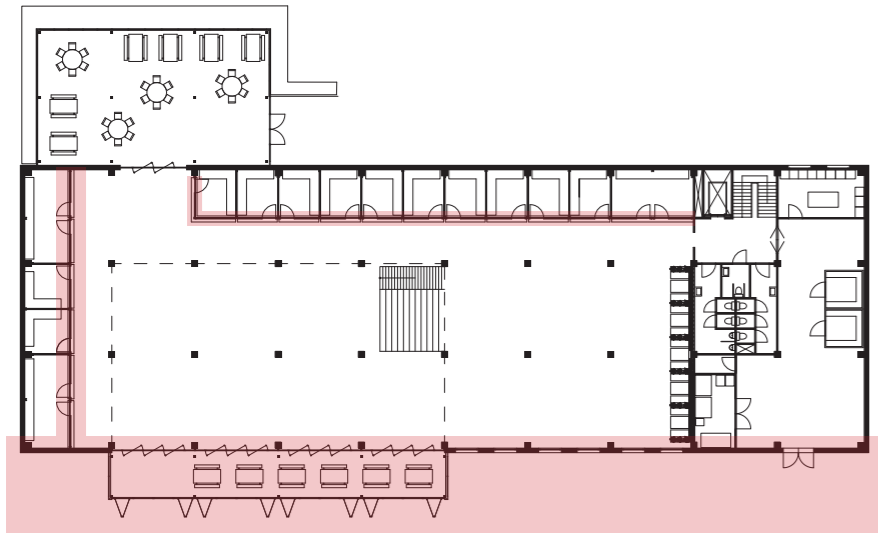

SPATIAL ELEMENTS & EXPERIENCE

FACADE

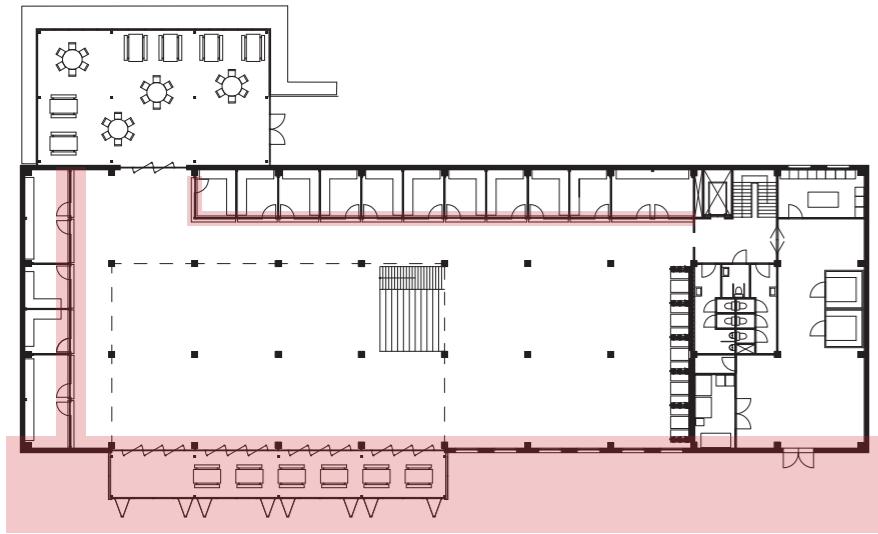

SPACE

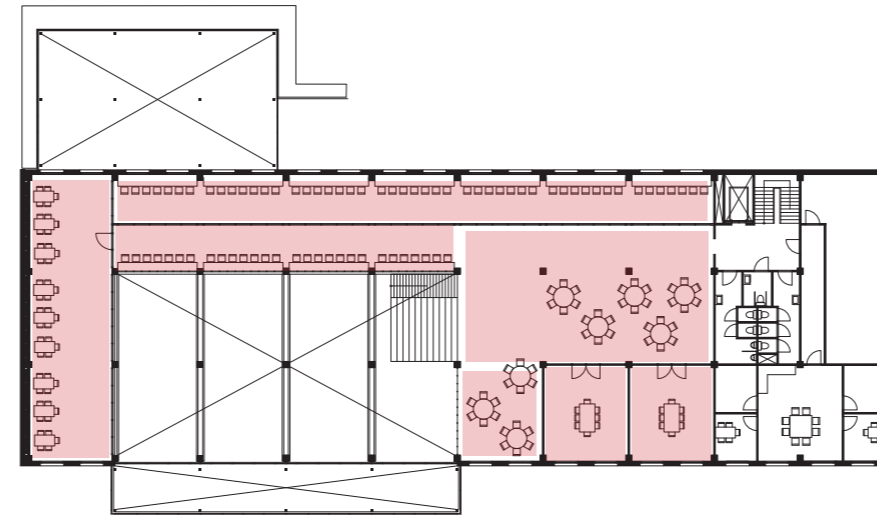
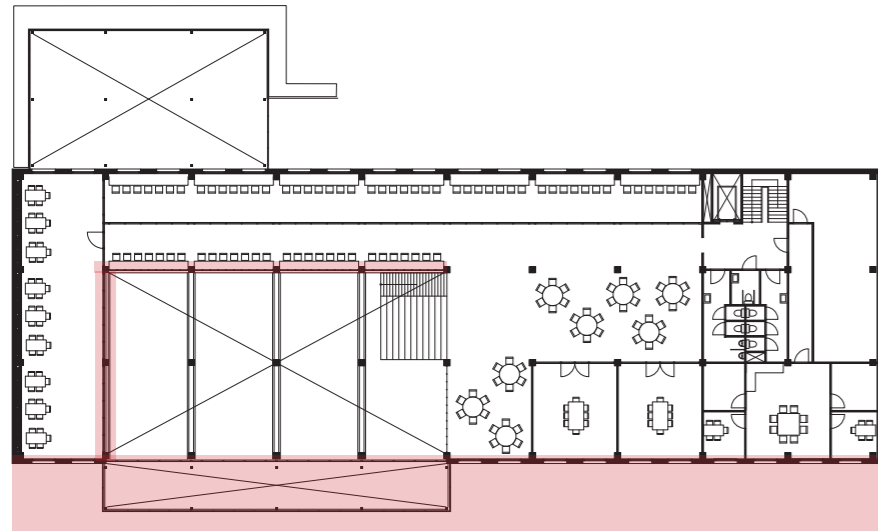
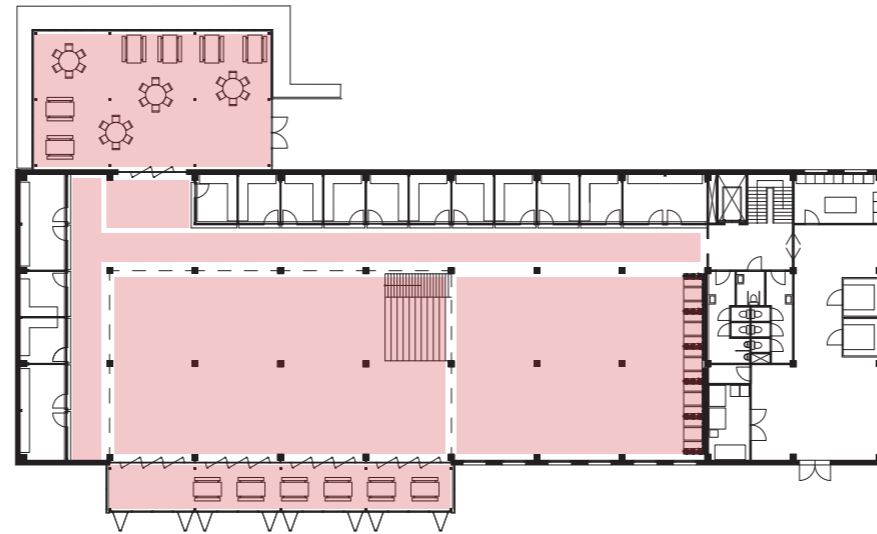

INTRODUCTION

RESEARCH

DESIGN

SPATIAL ELEMENTS & EXPERIENCE

FACADE

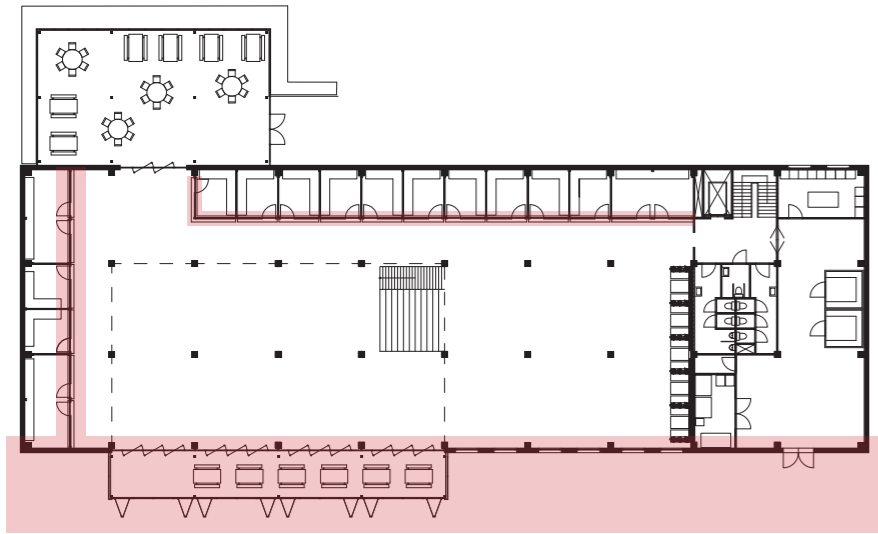

SPACE

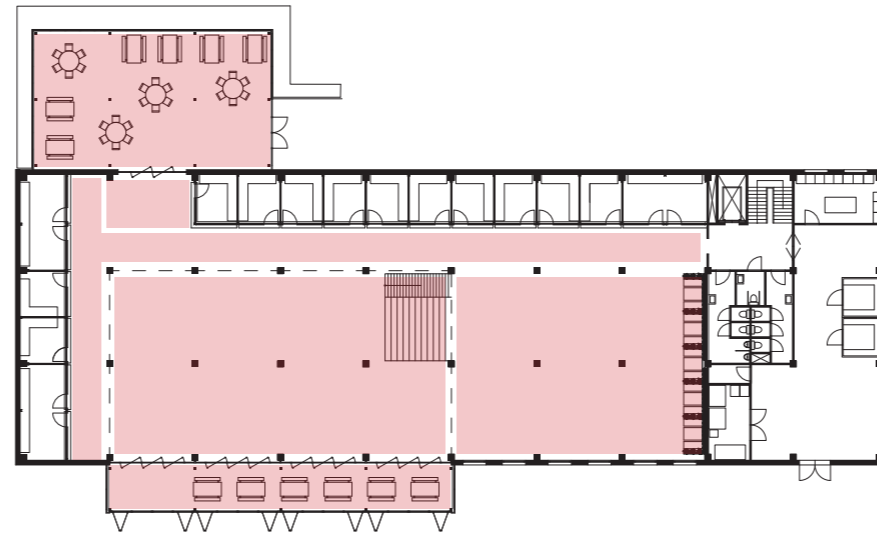

OBJECTS

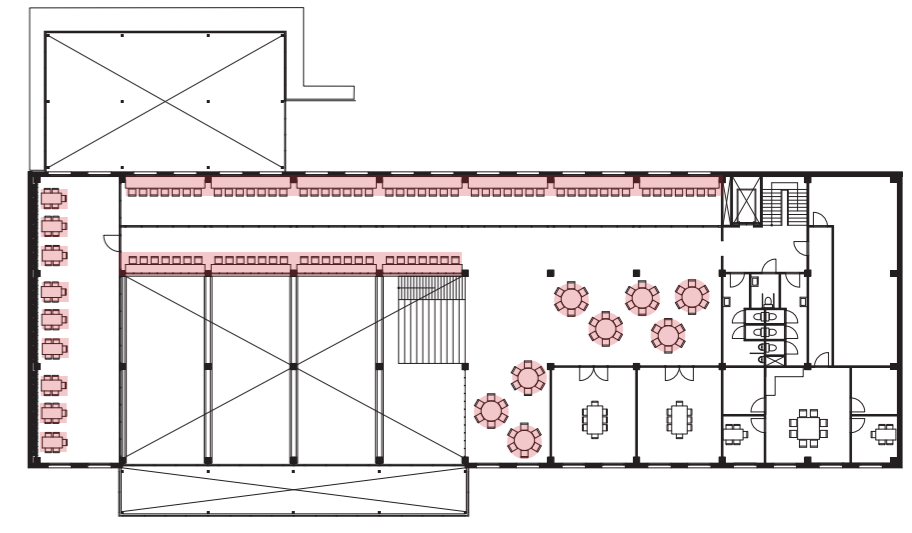
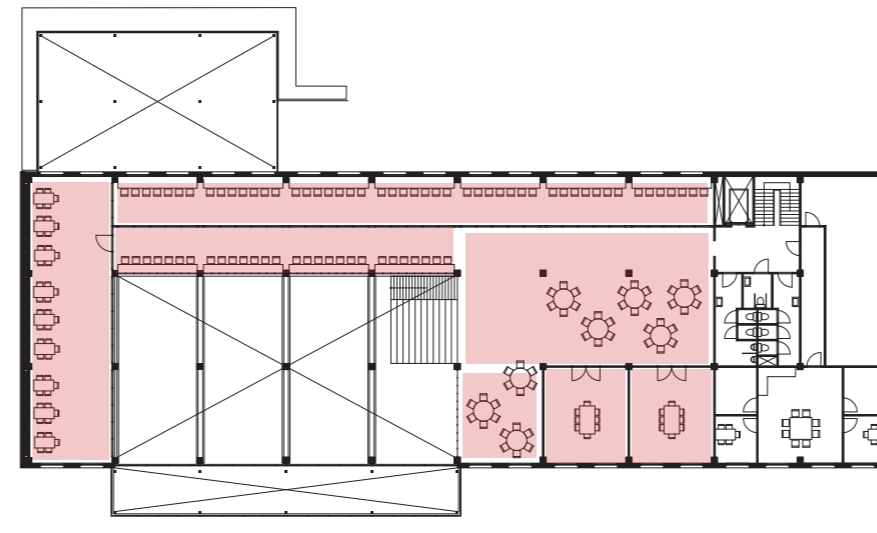
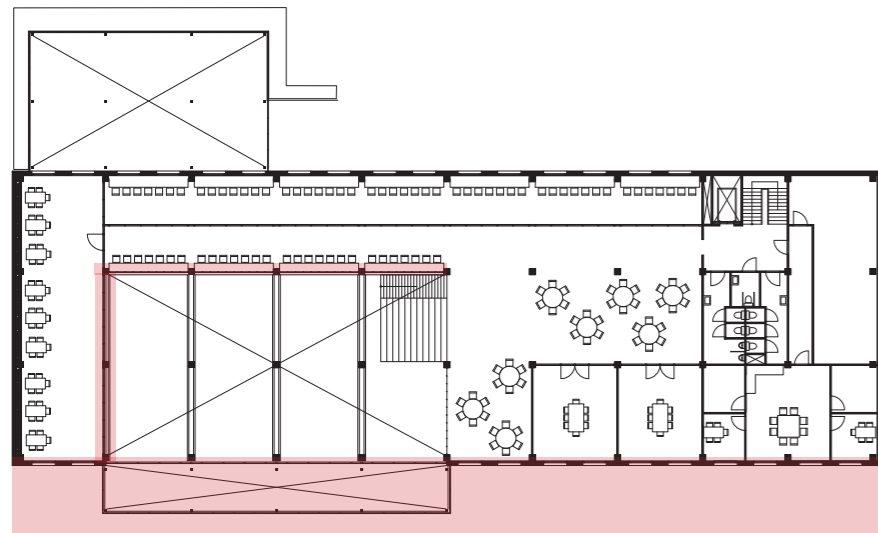
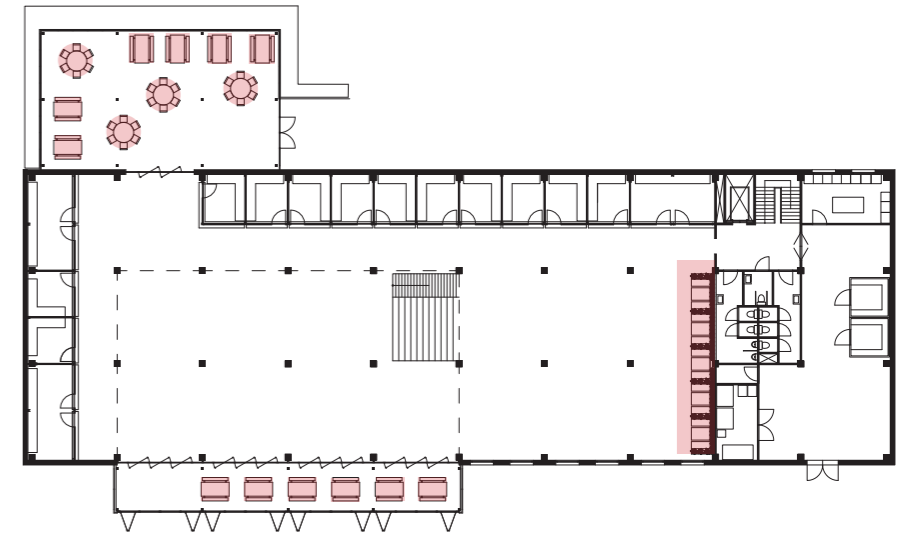

INTRODUCTION

RESEARCH

DESIGN

FUTURE USE/AFTER USE: SHEARING LAYERS

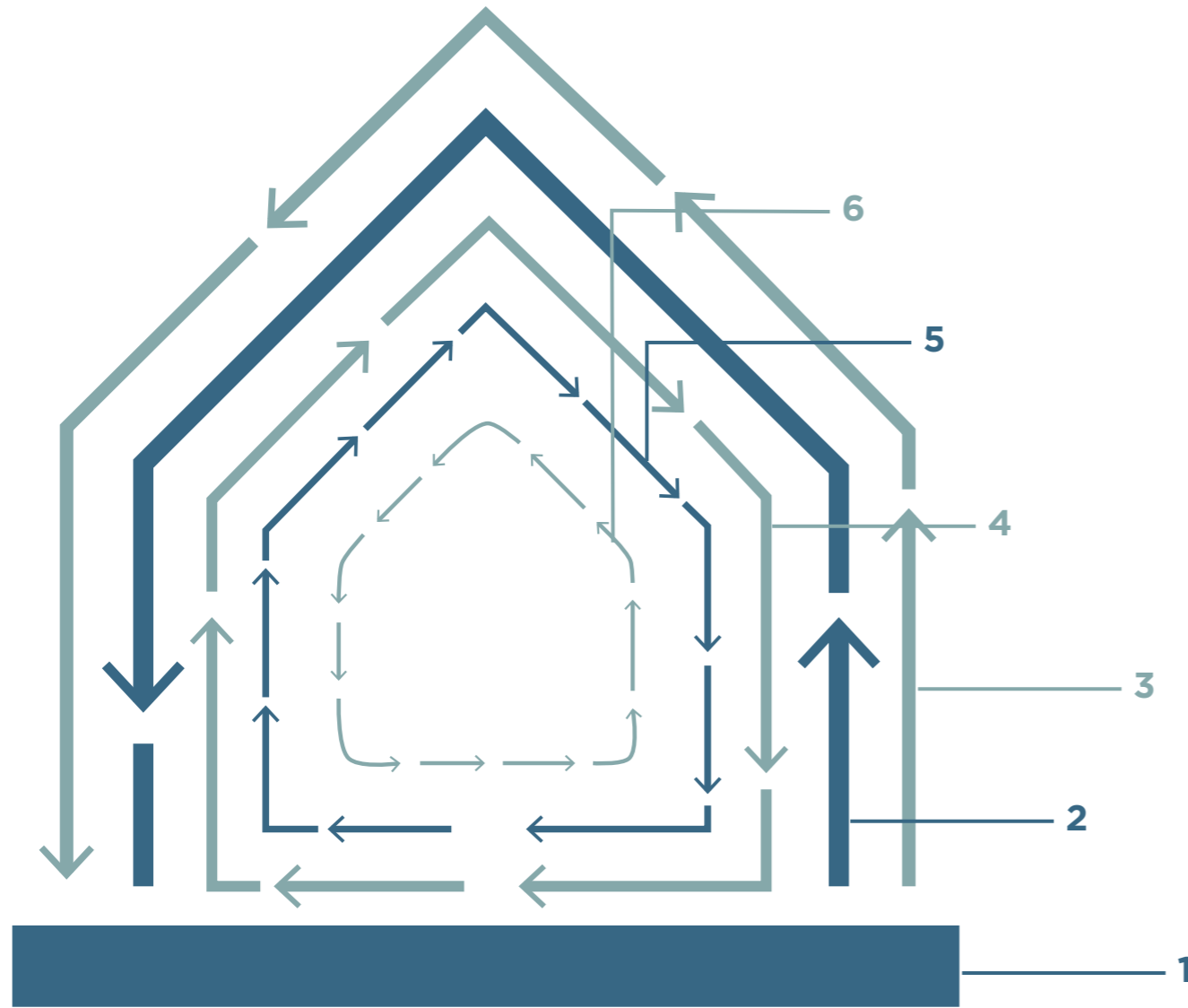

- 1. SITE
- 2. STRUCTURE
- 3. SKIN
- 4. SERVICES
- 5. SPACE PLAN
- 6. STUFF

- 'ETERNAL'
- 60-200 YRS
- 30-60 YRS
- 5-30 YRS
- 5-20 YRS
- 5-15 YRS

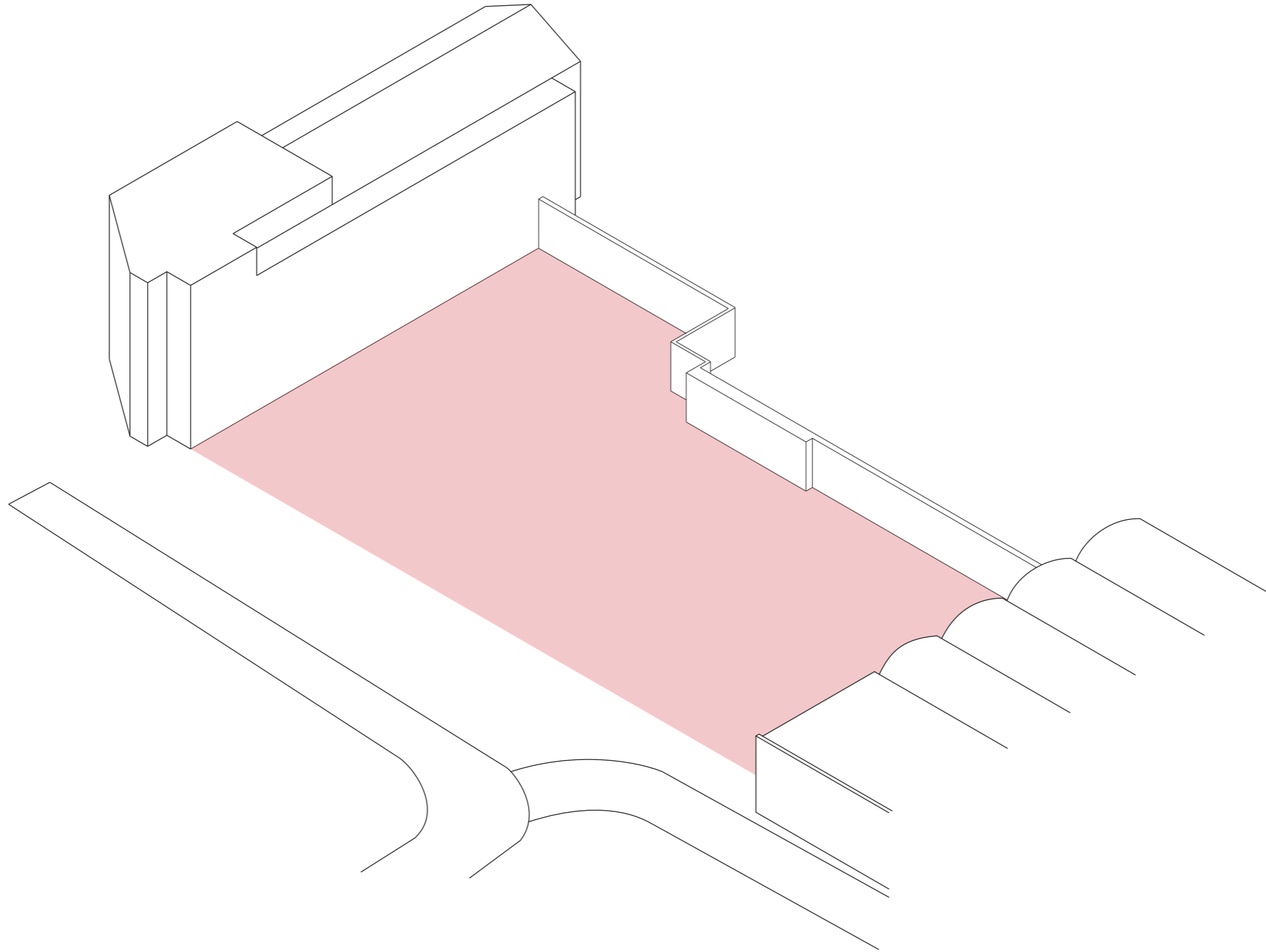
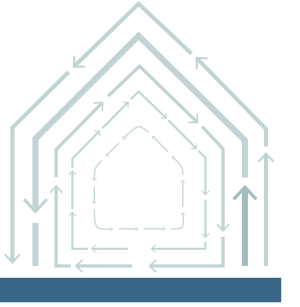

SITE: DELFT CITY CENTER SHOPPING AREA



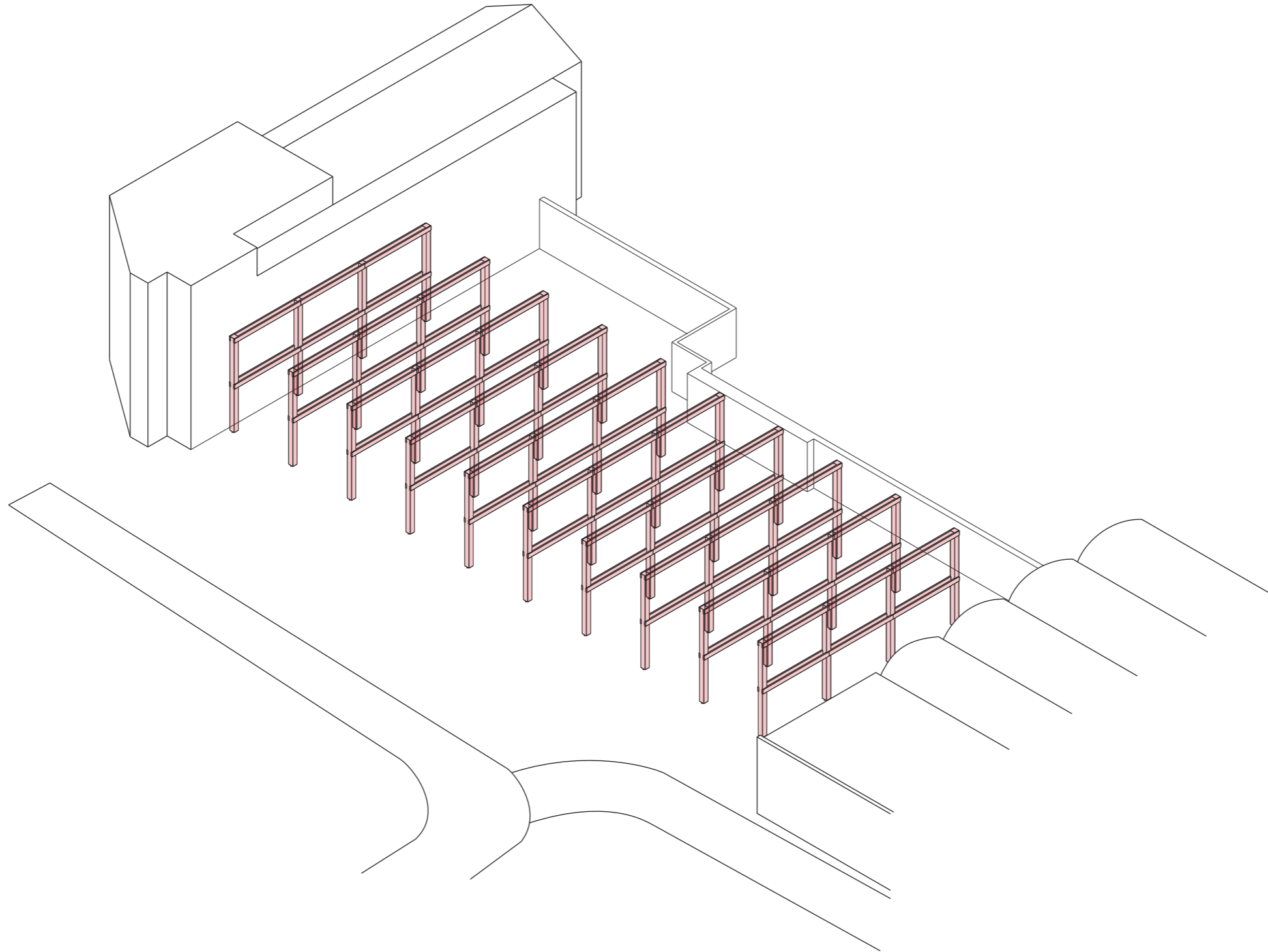
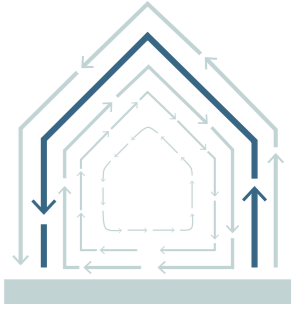

STRUCTURE: PROPERTIES

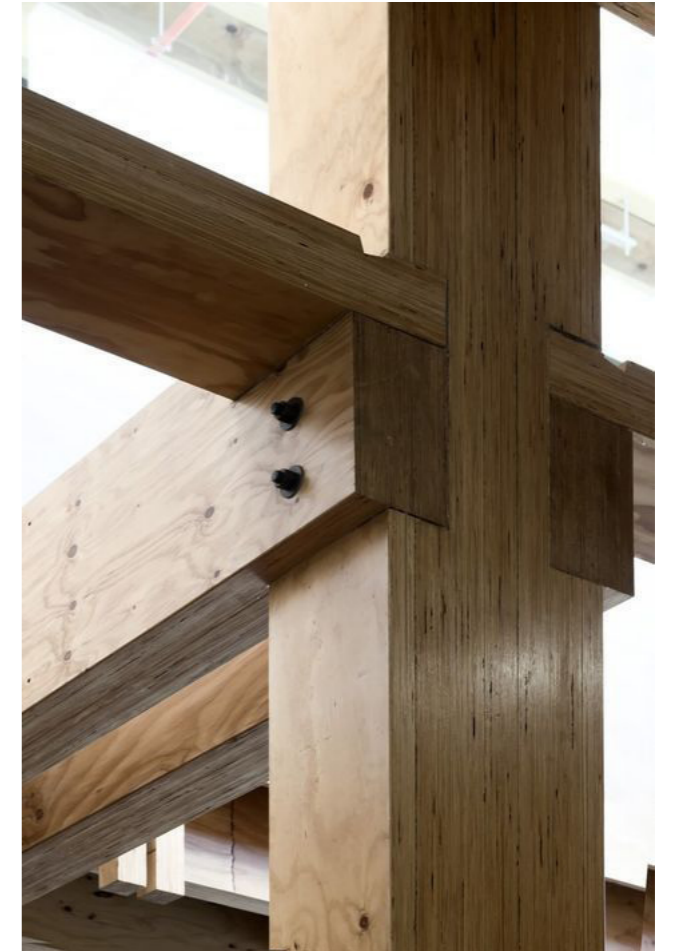
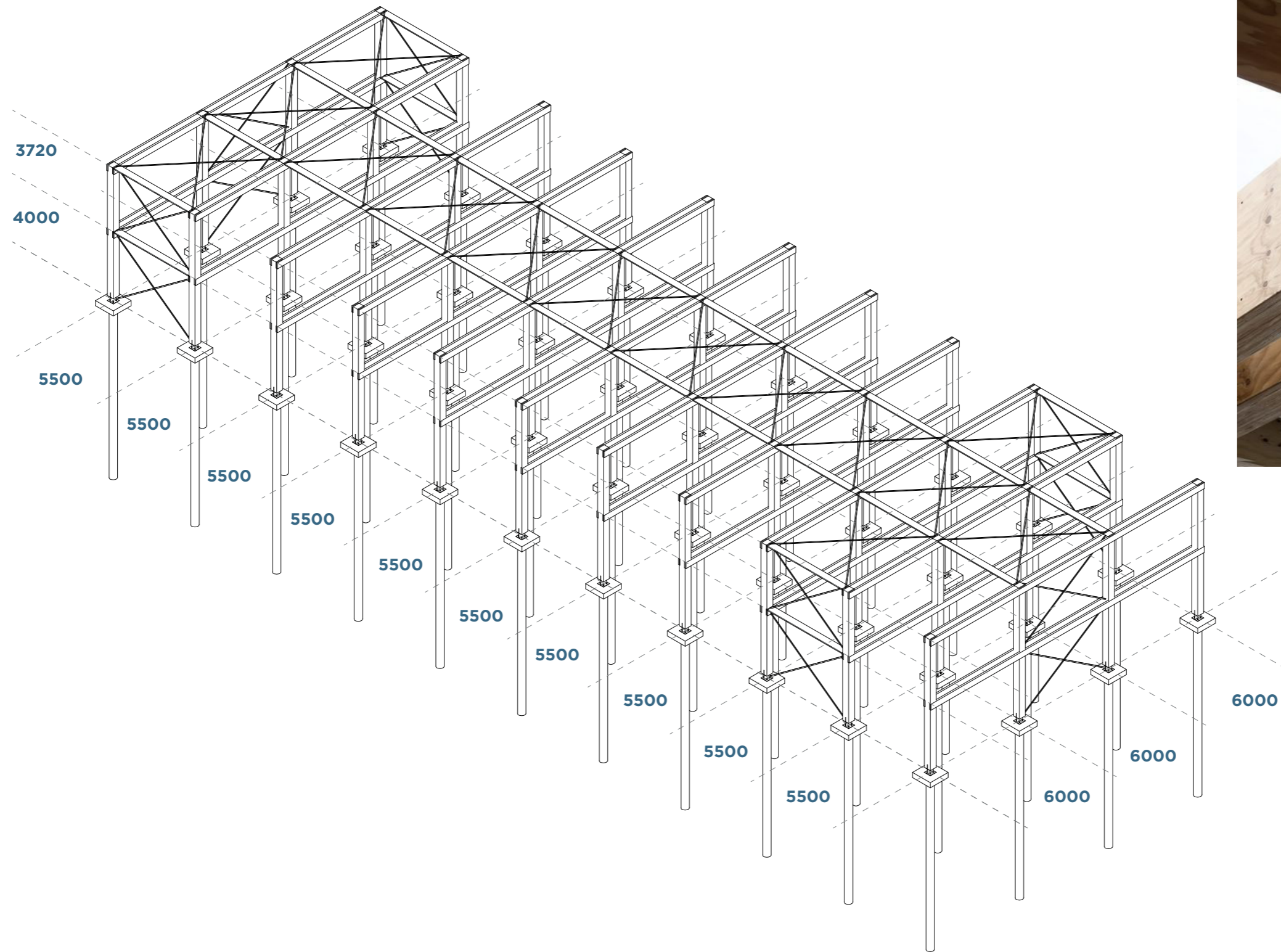

STRUCTURE: DETAILS

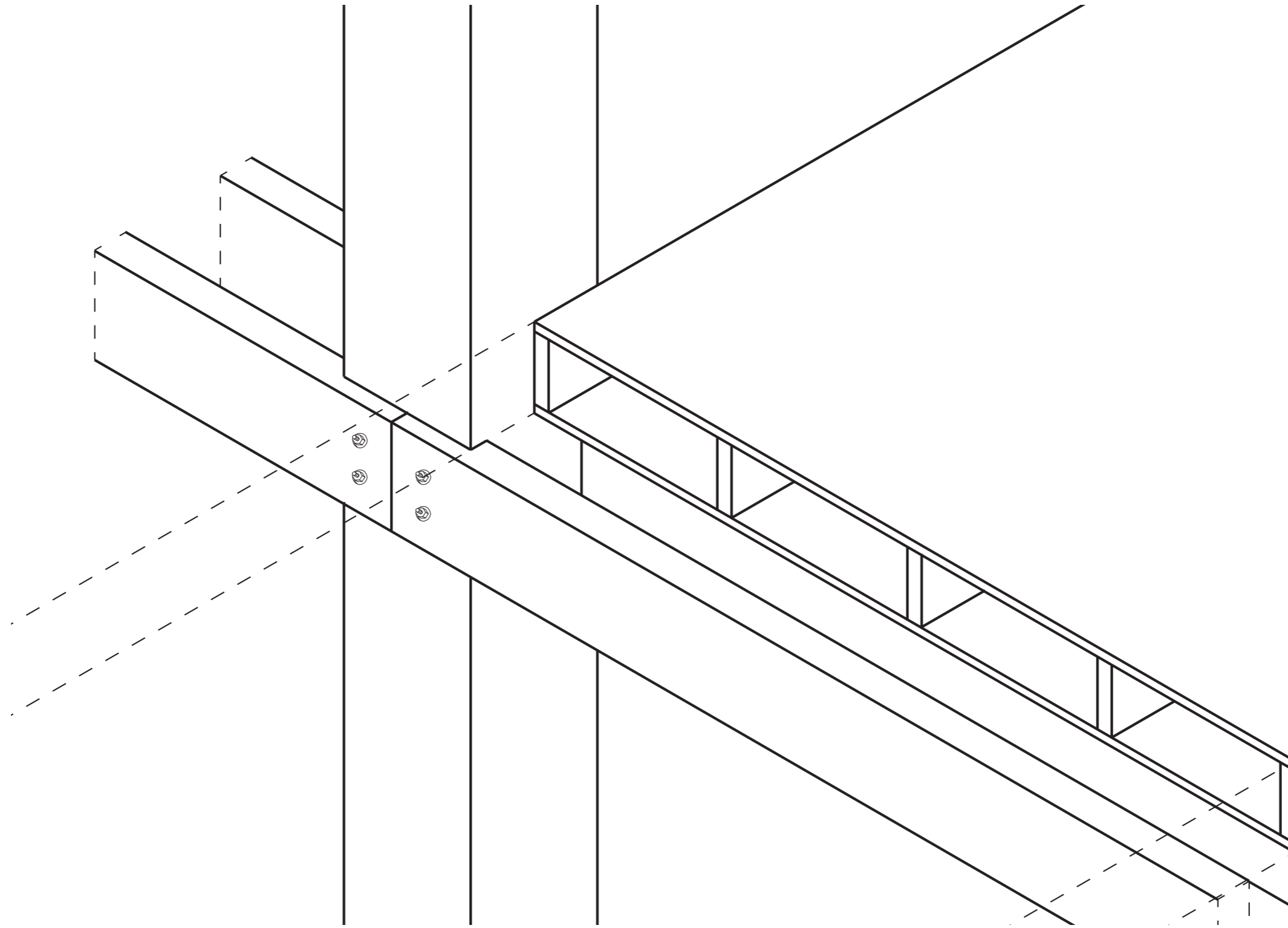

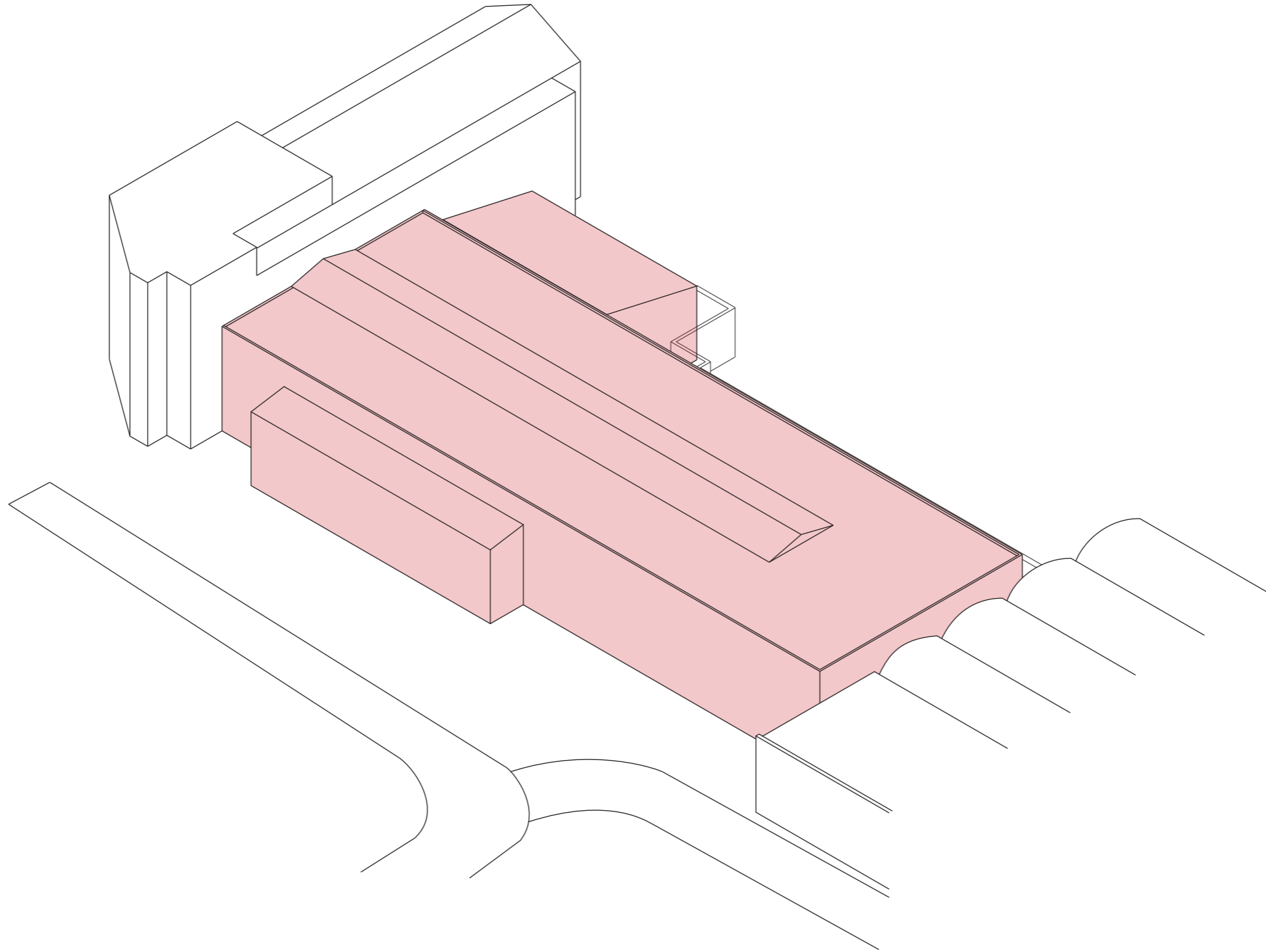
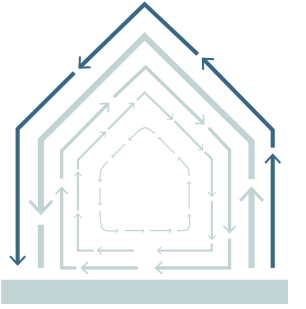

SKIN: GREEN ROOF

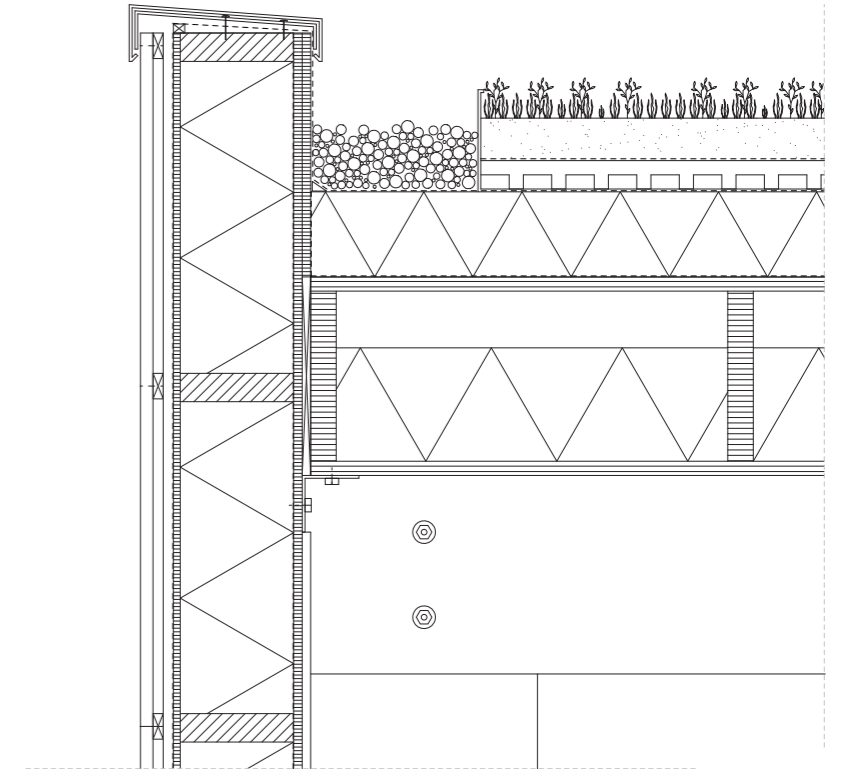
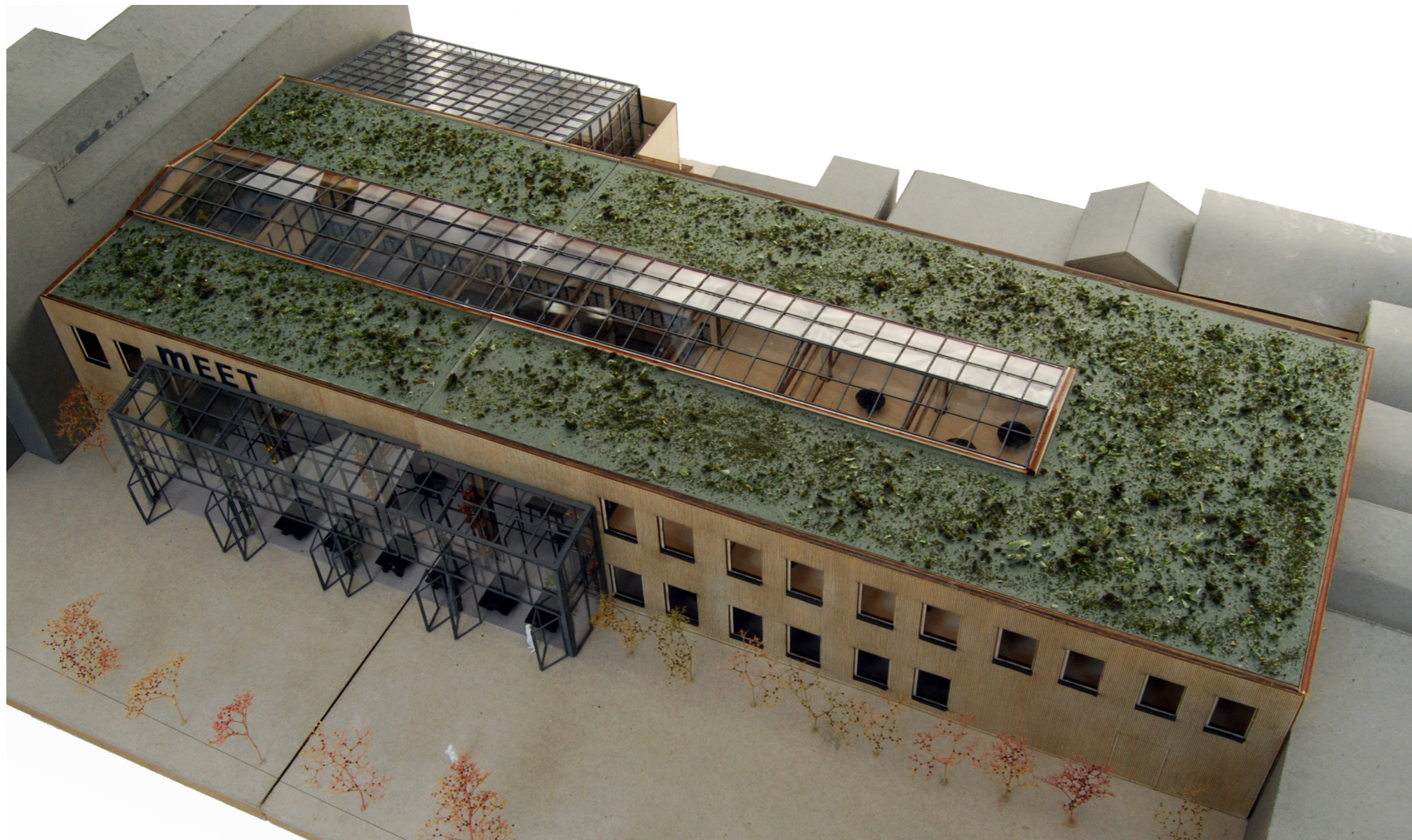

SKIN: MATERIALIZATION

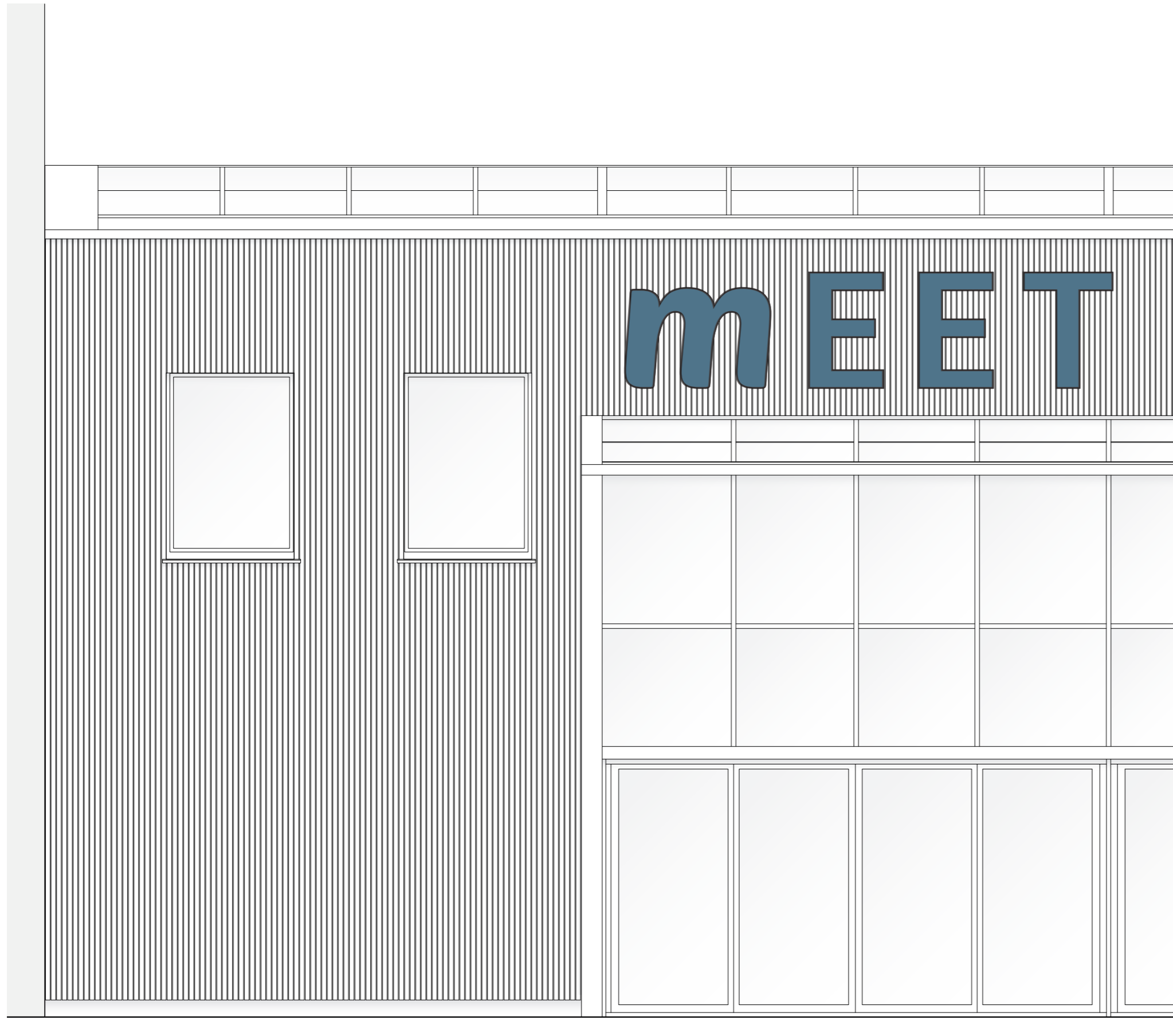

SKIN: EXPERIENCE FACADE



SKIN: EXPERIENCE FACADE

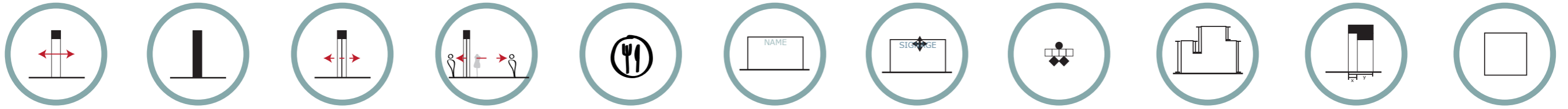

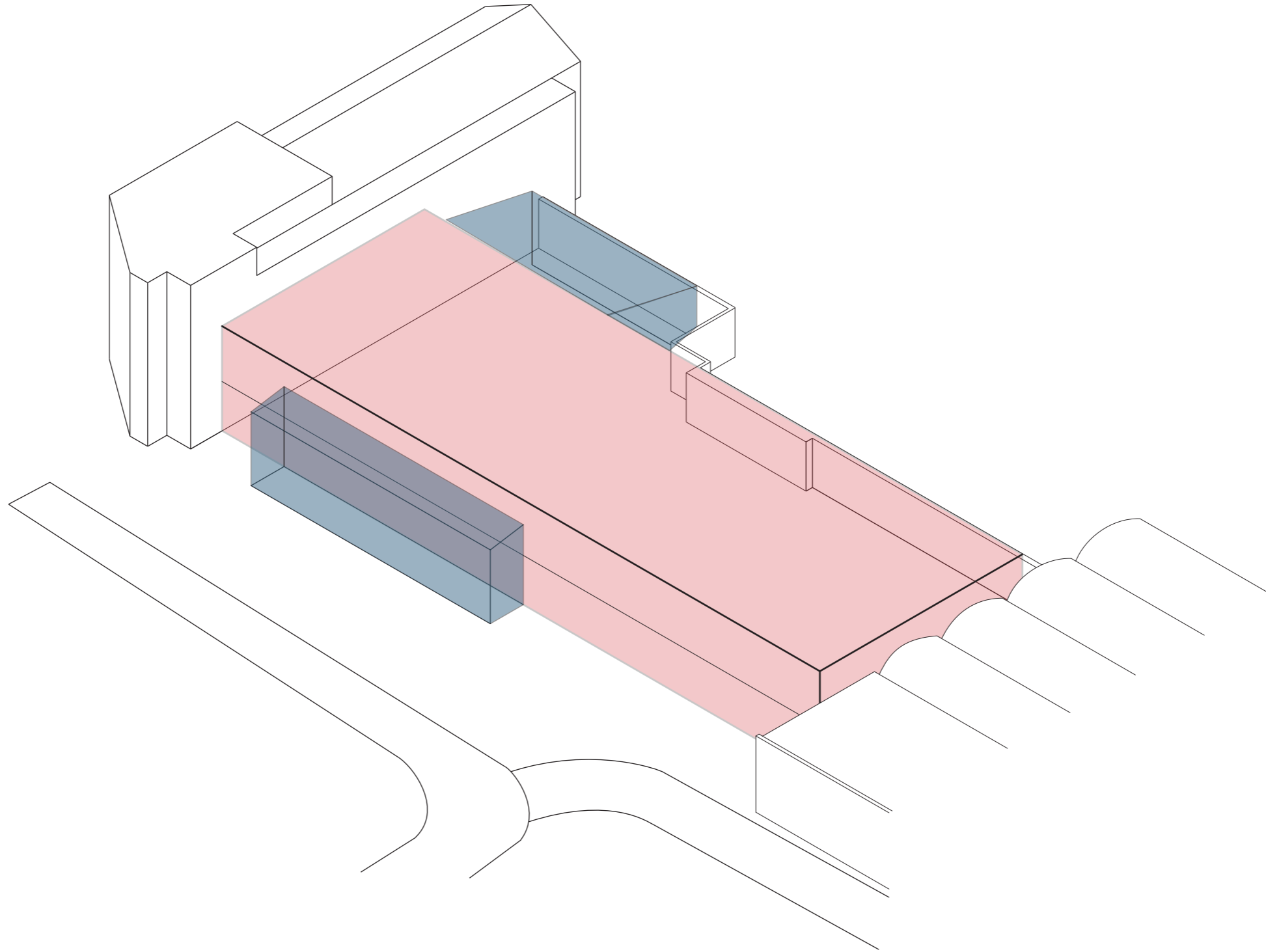

SKIN: 1:20 SECTION

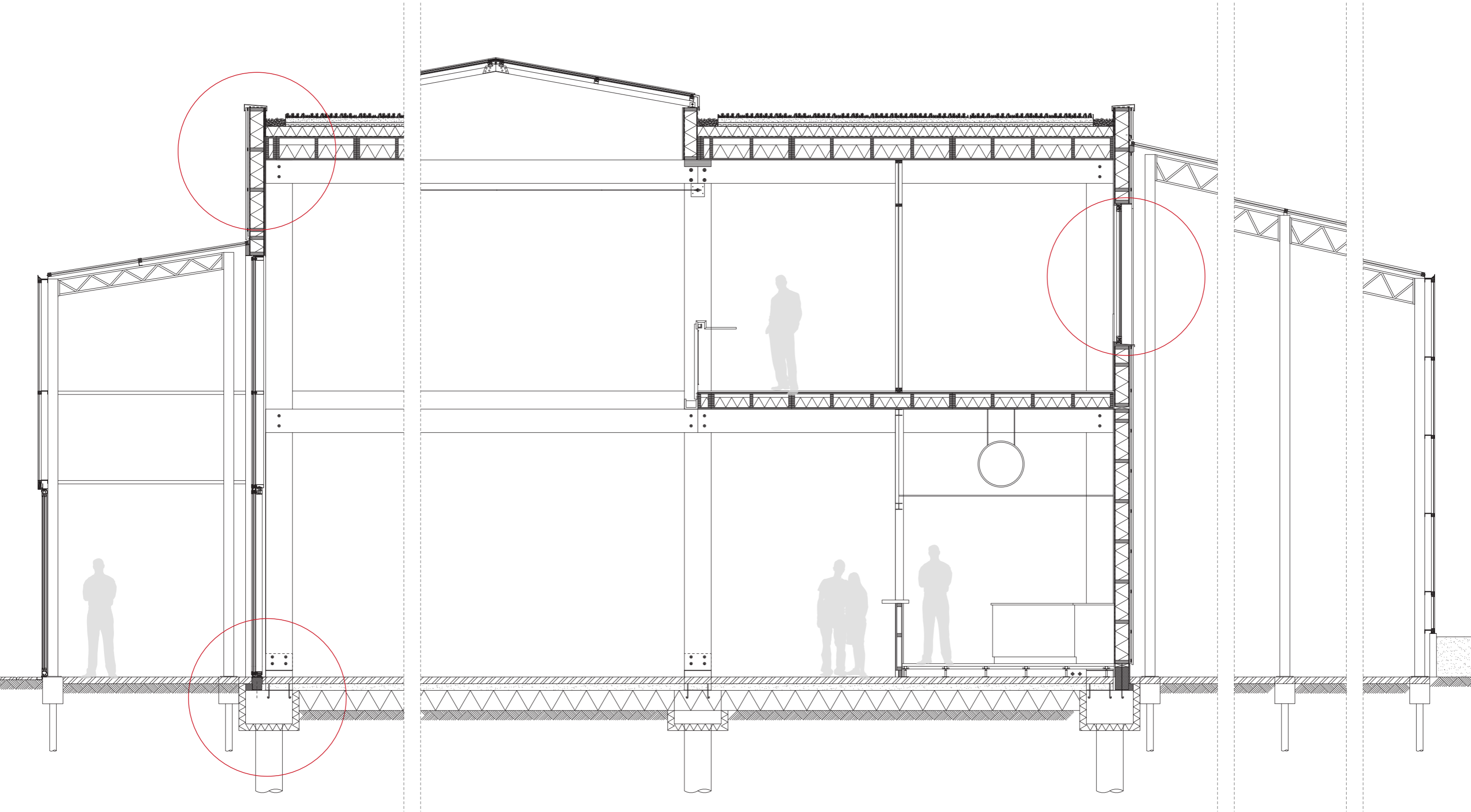

INTRODUCTION

RESEARCH

DESIGN

SKIN: INSULATION

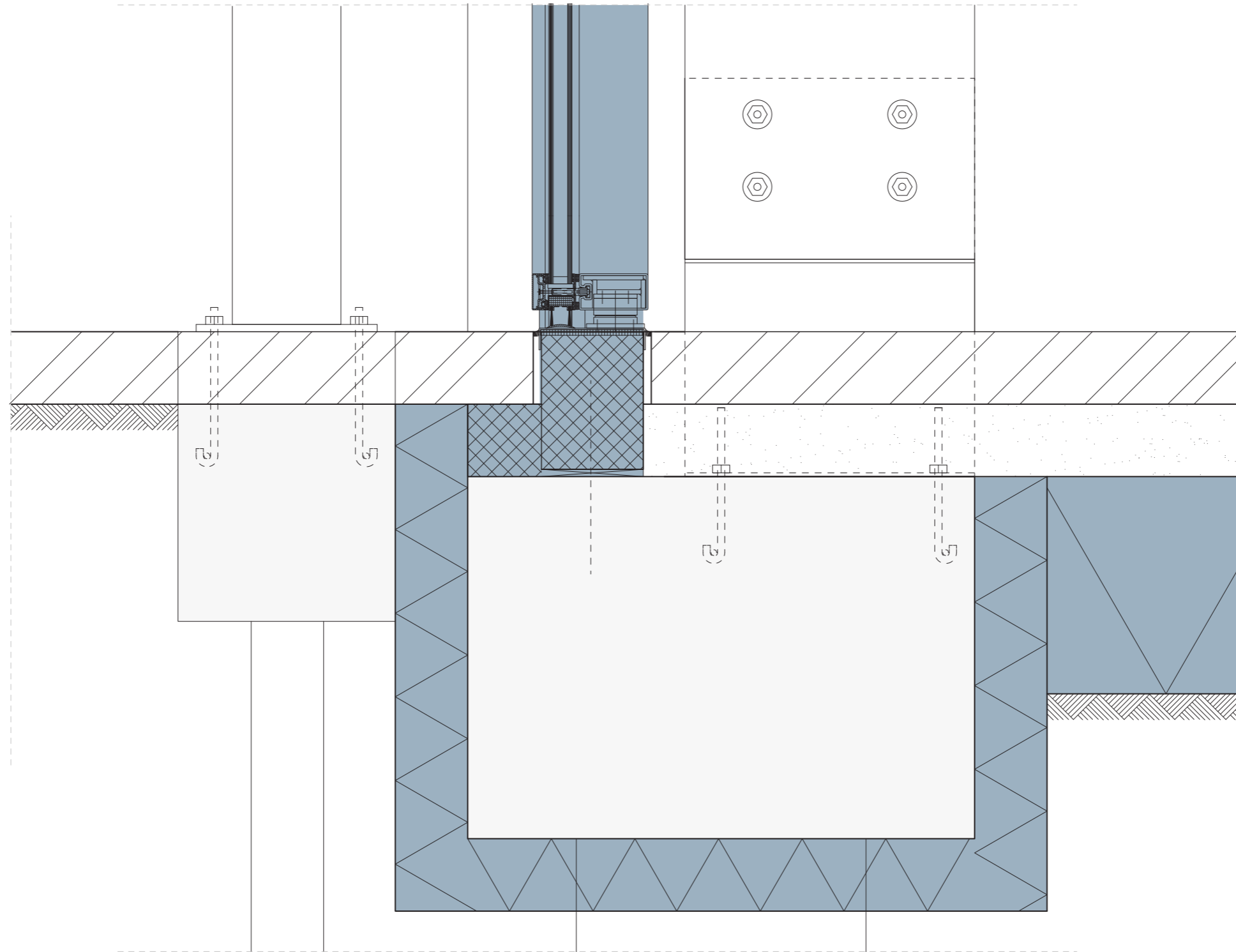

SKIN: CLIMATE

SUMMER

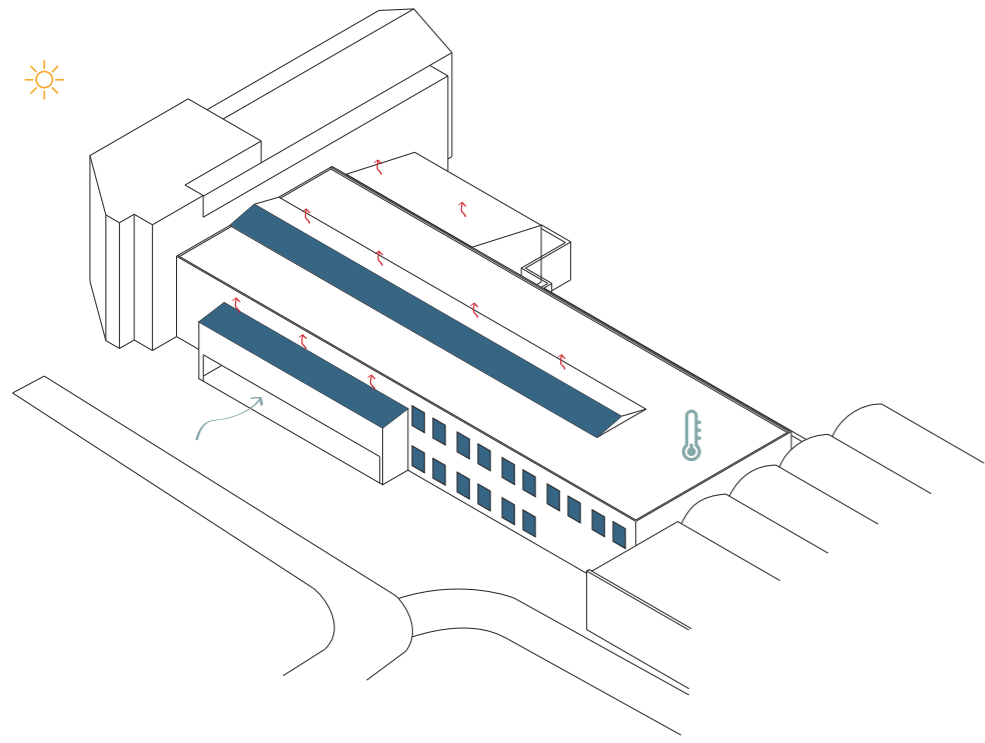

INTRODUCTION

RESEARCH

DESIGN

SKIN: CLIMATE

SUMMER

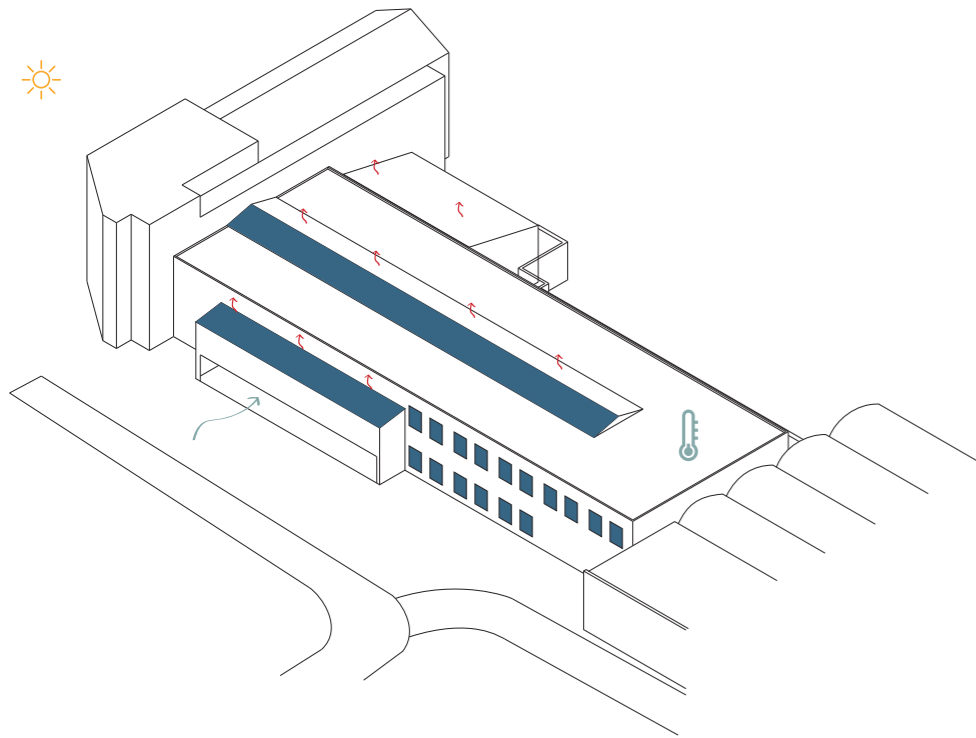

WINTER

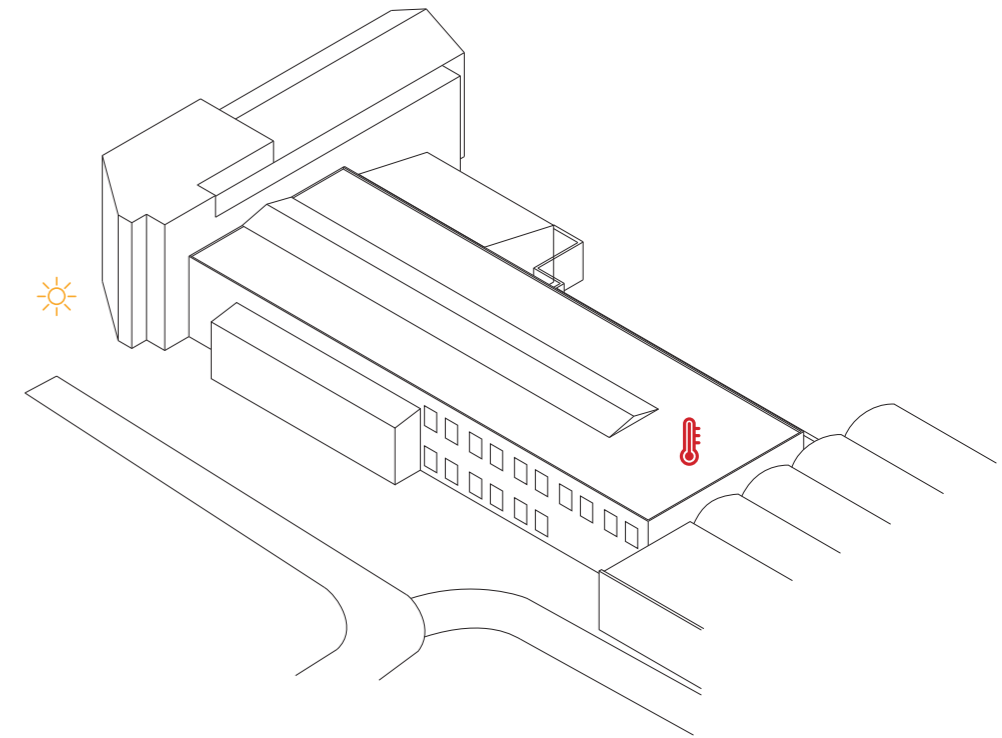

INTRODUCTION

RESEARCH



DESIGN

SKIN: CLIMATE

SUMMER

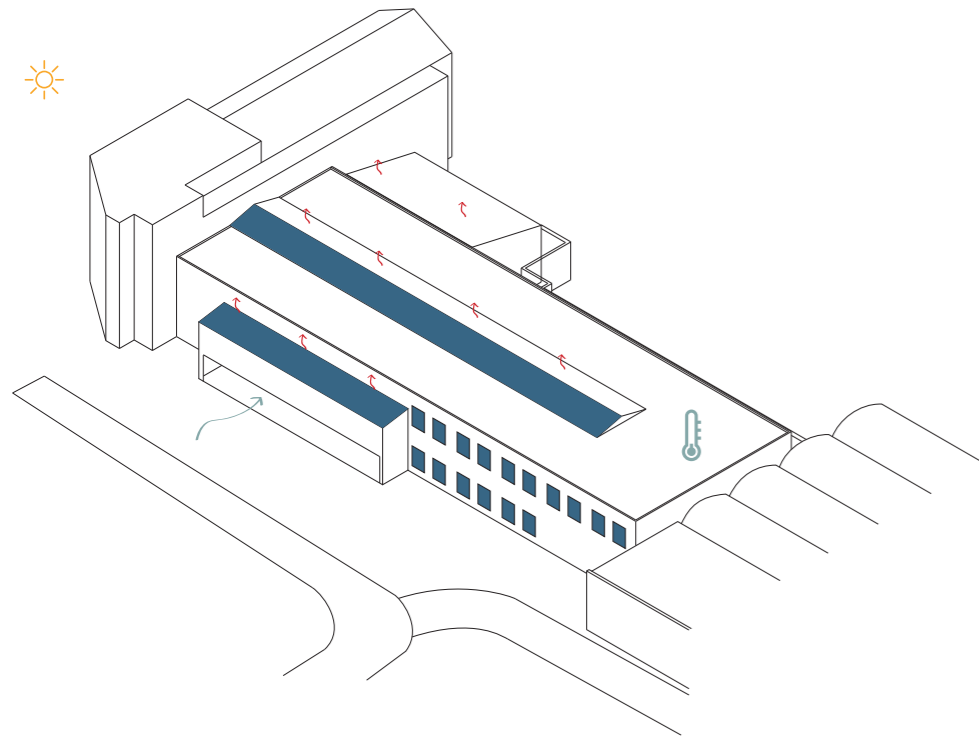

SPRING/FALL

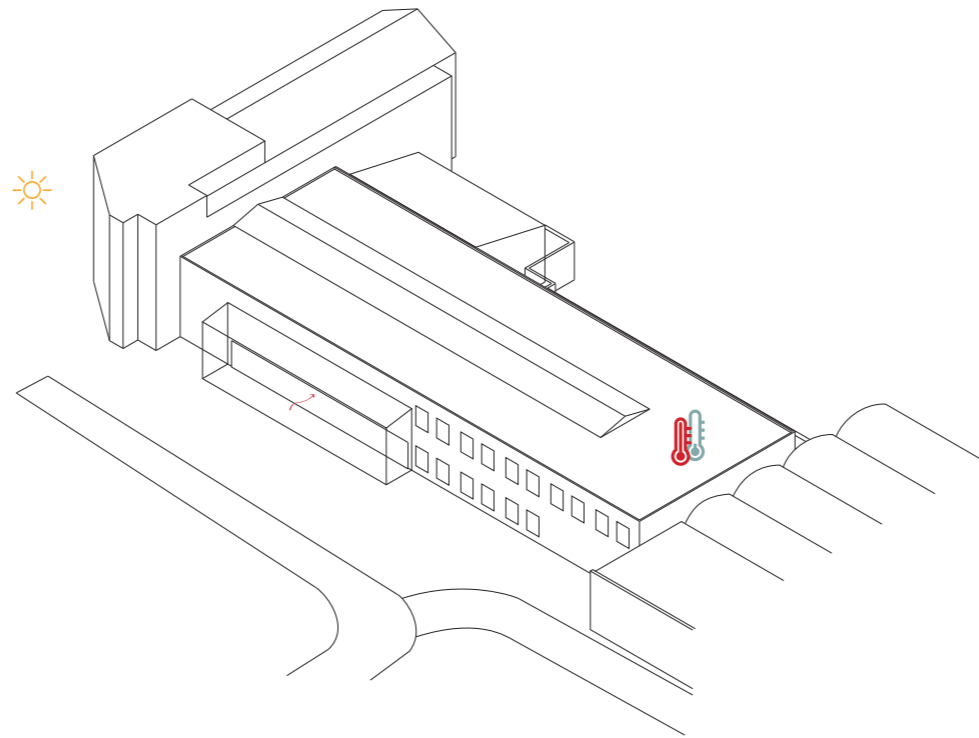

WINTER

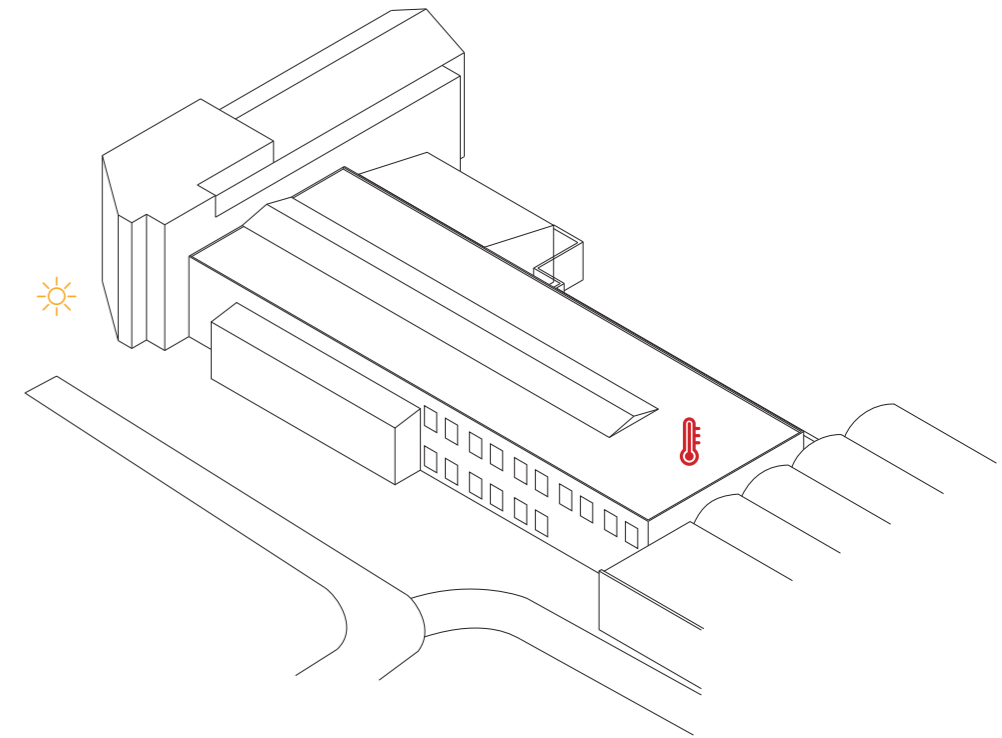

INTRODUCTION



RESEARCH



DESIGN

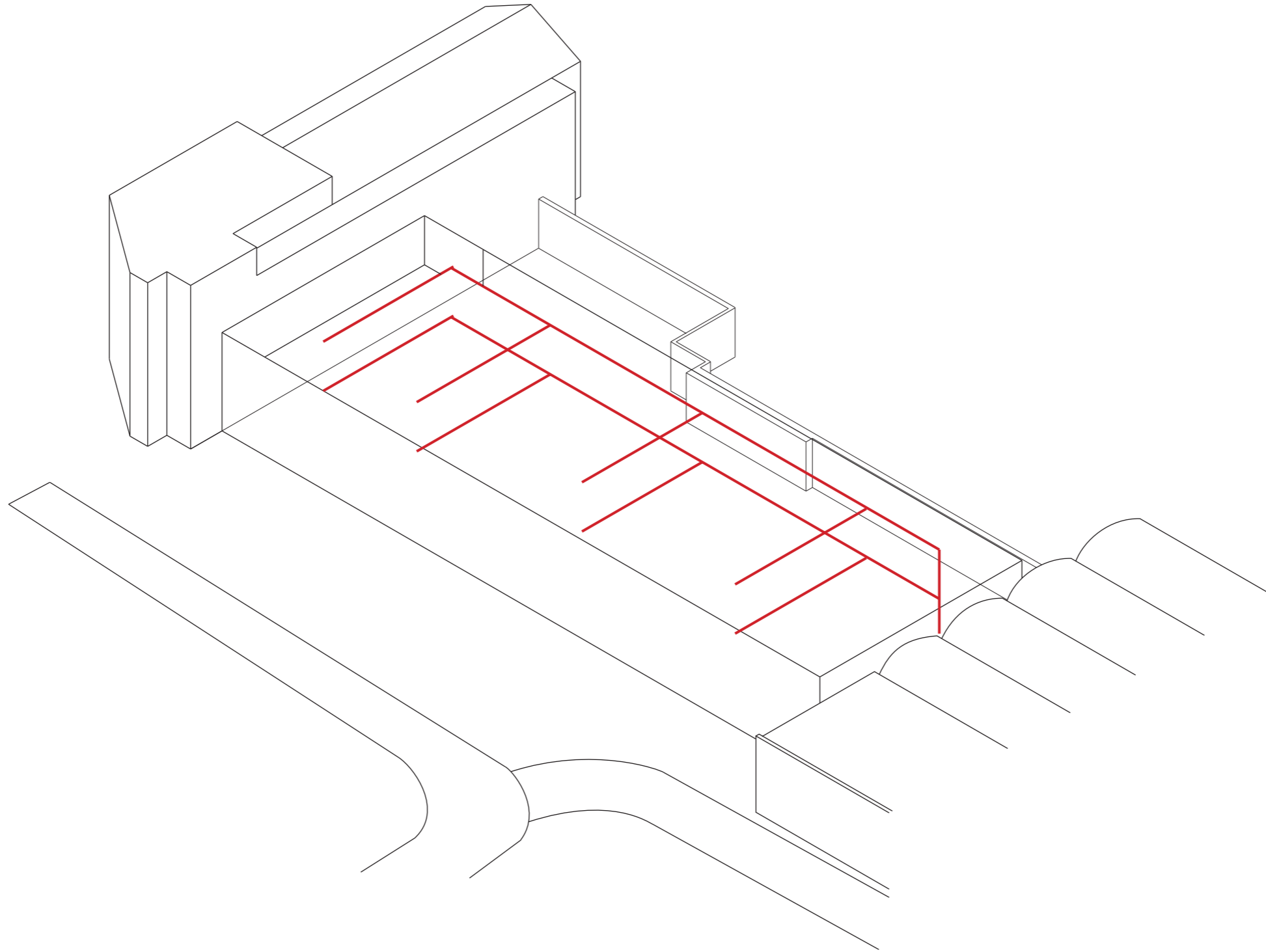
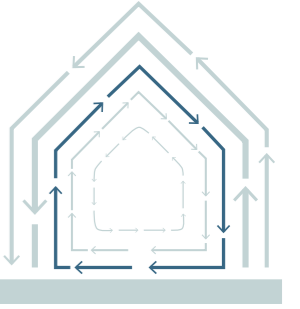

SERVICES: VENTILATION

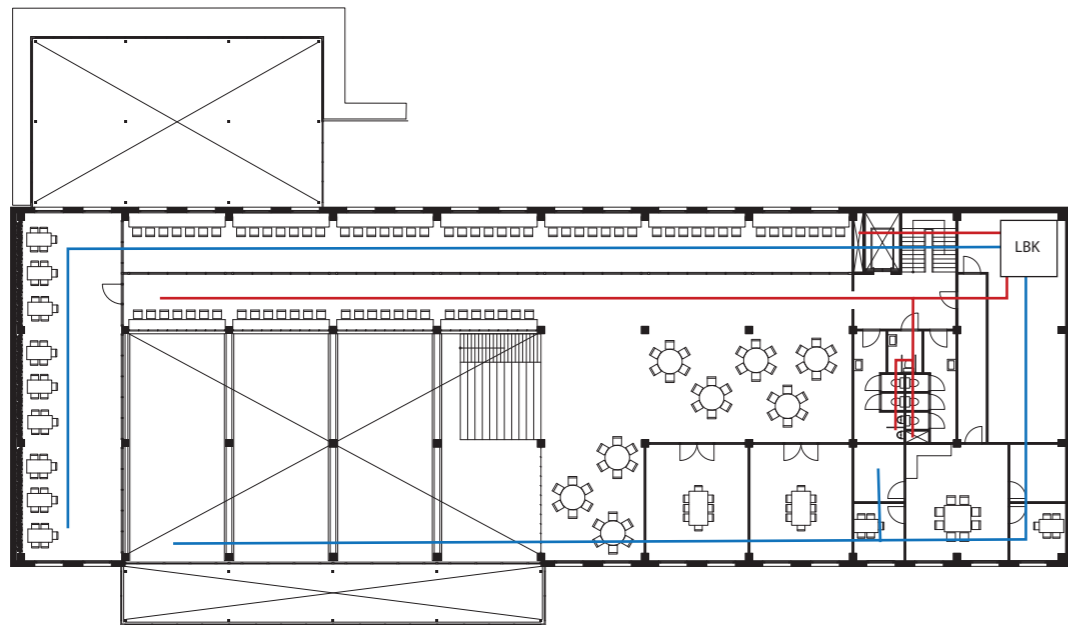
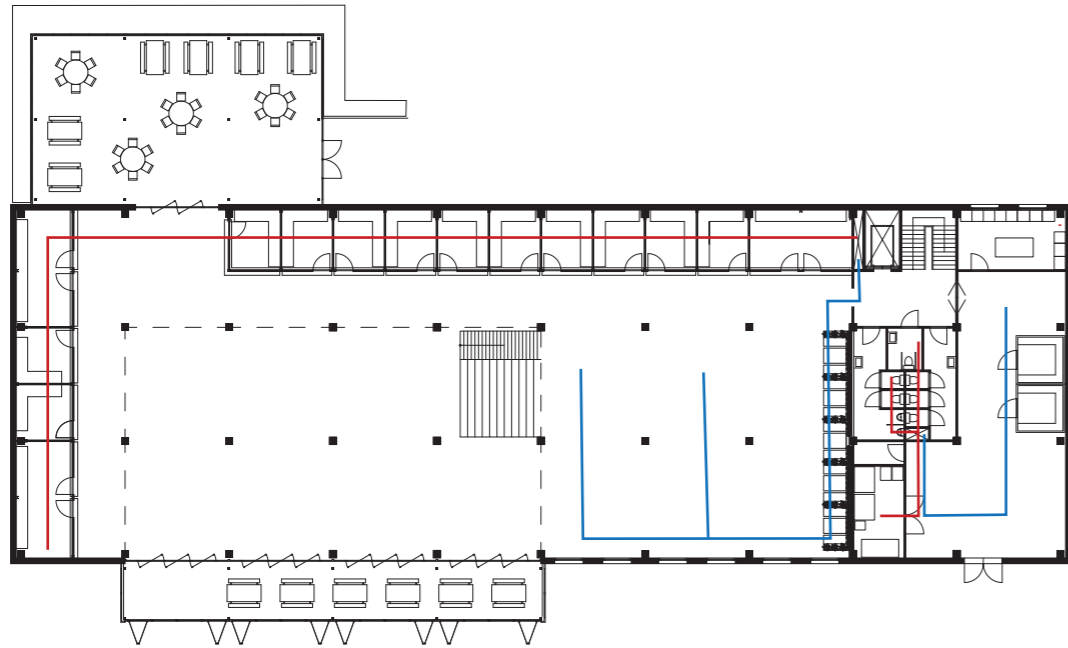

INTRODUCTION

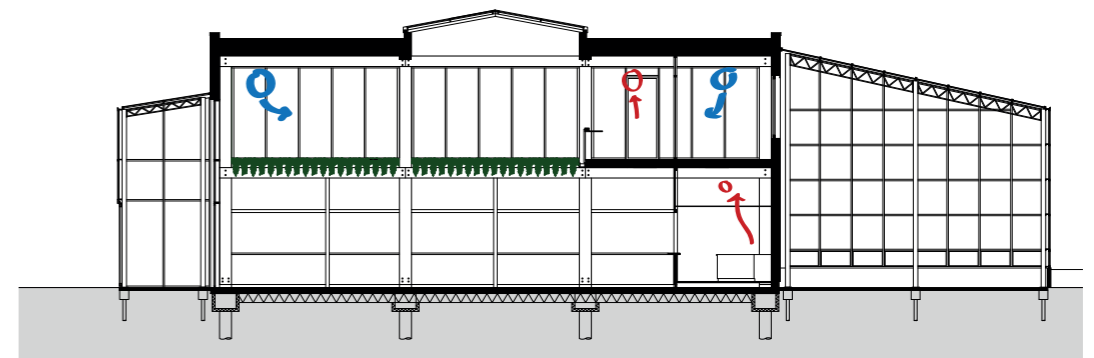

RESEARCH

DESIGN

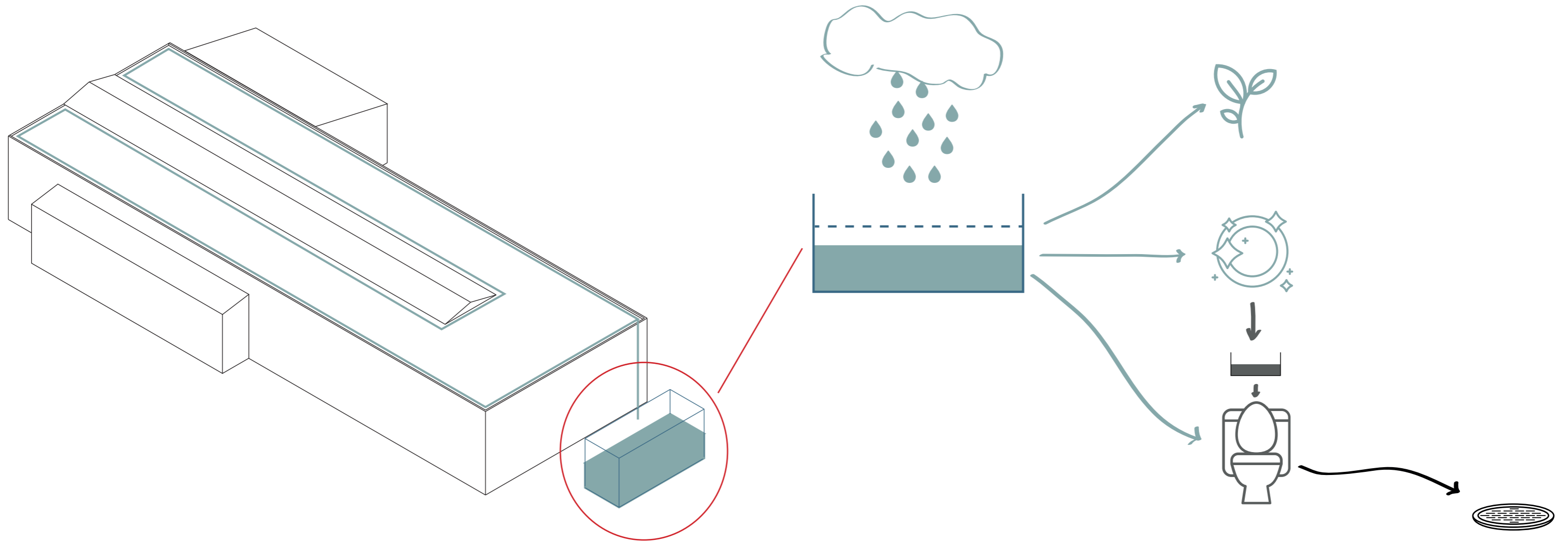

SERVICES: ENERGY

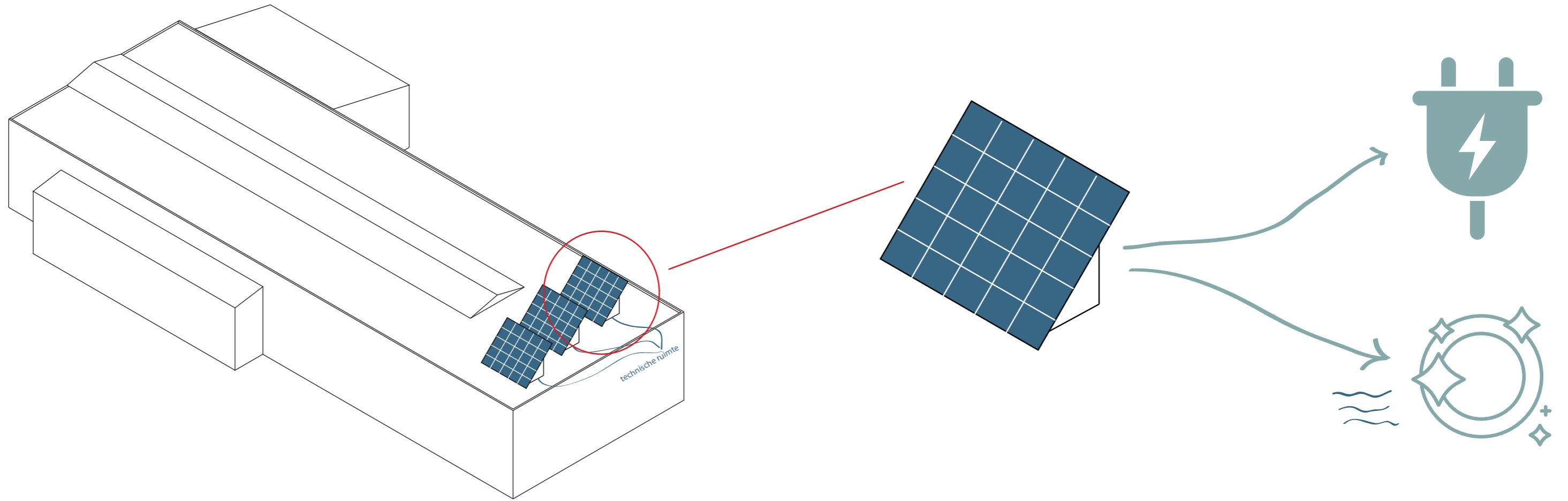

INTRODUCTION

RESEARCH

DESIGN

SERVICES: INTEGRATION

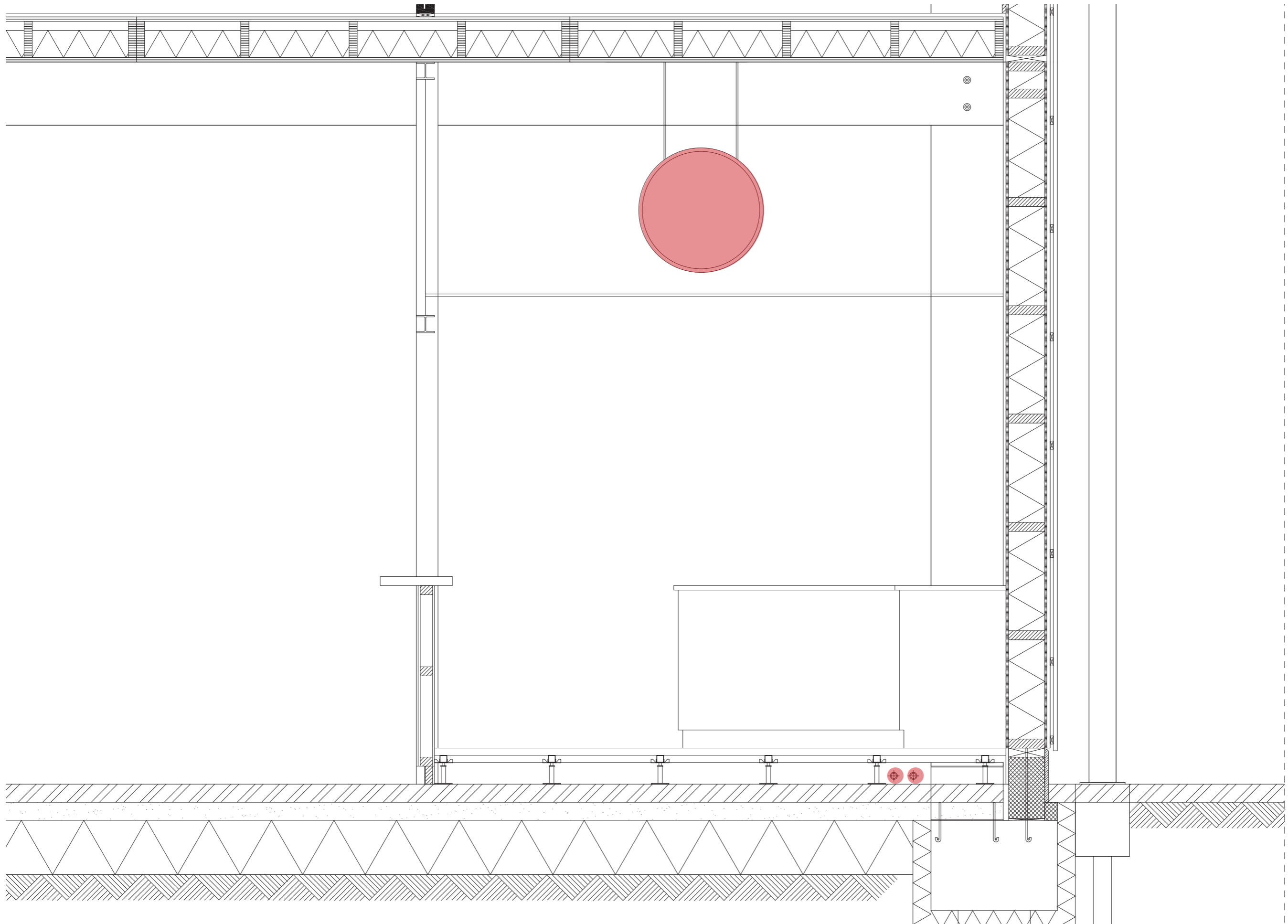

INTRODUCTION

RESEARCH

DESIGN

SPACE PLAN

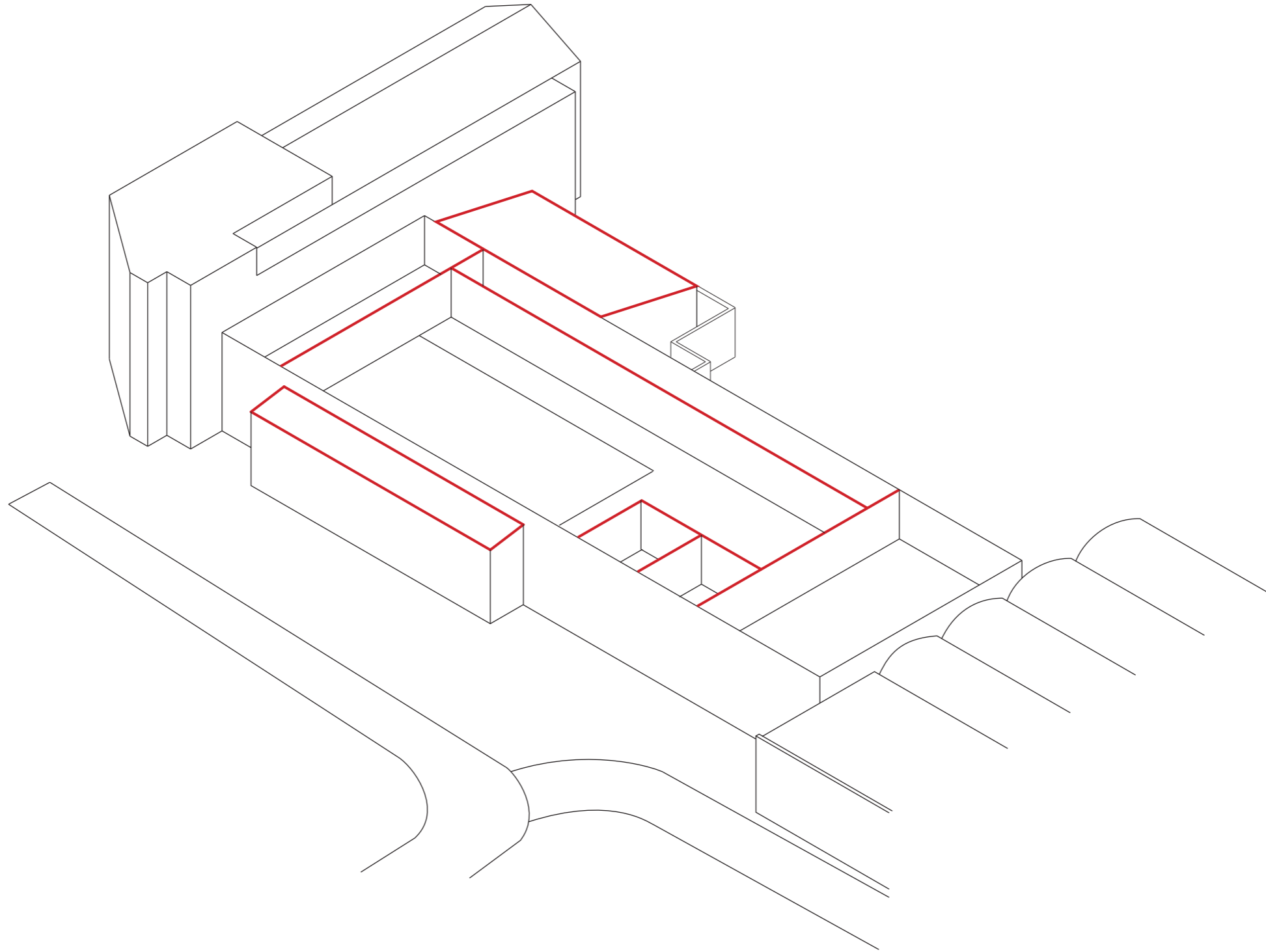

SPACE PLAN: FUNCTIONAL

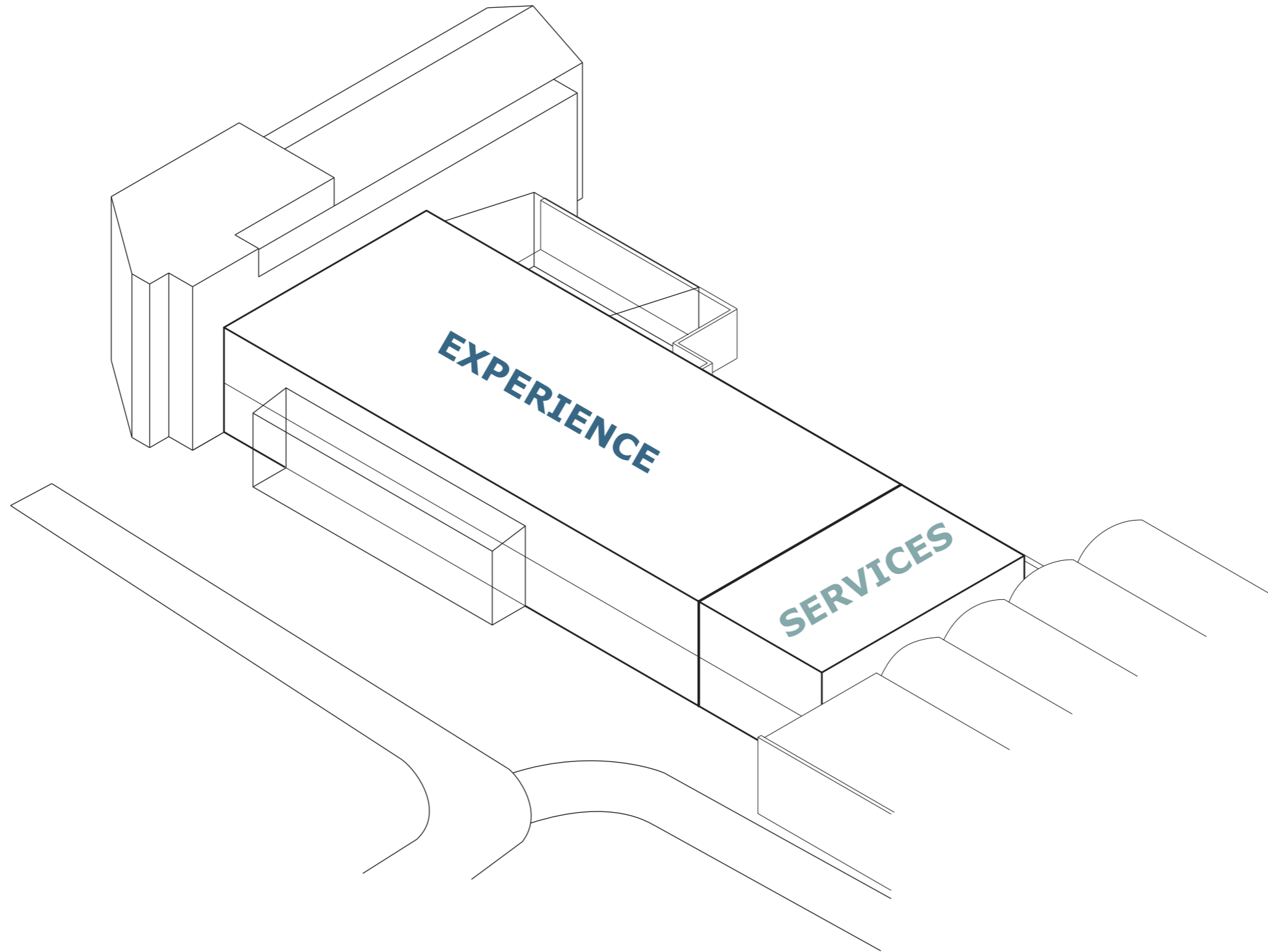

SPACE PLAN: EXPERIENCE SPACE



SPACE PLAN: EXPERIENCE SPACE

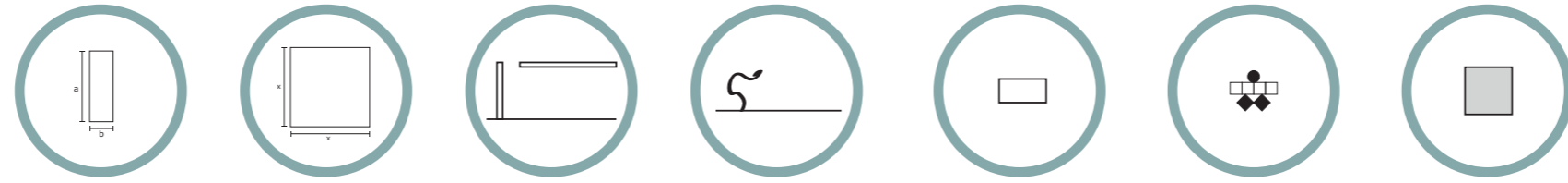

SPACE PLAN: MATERIALIZATION FLOORS

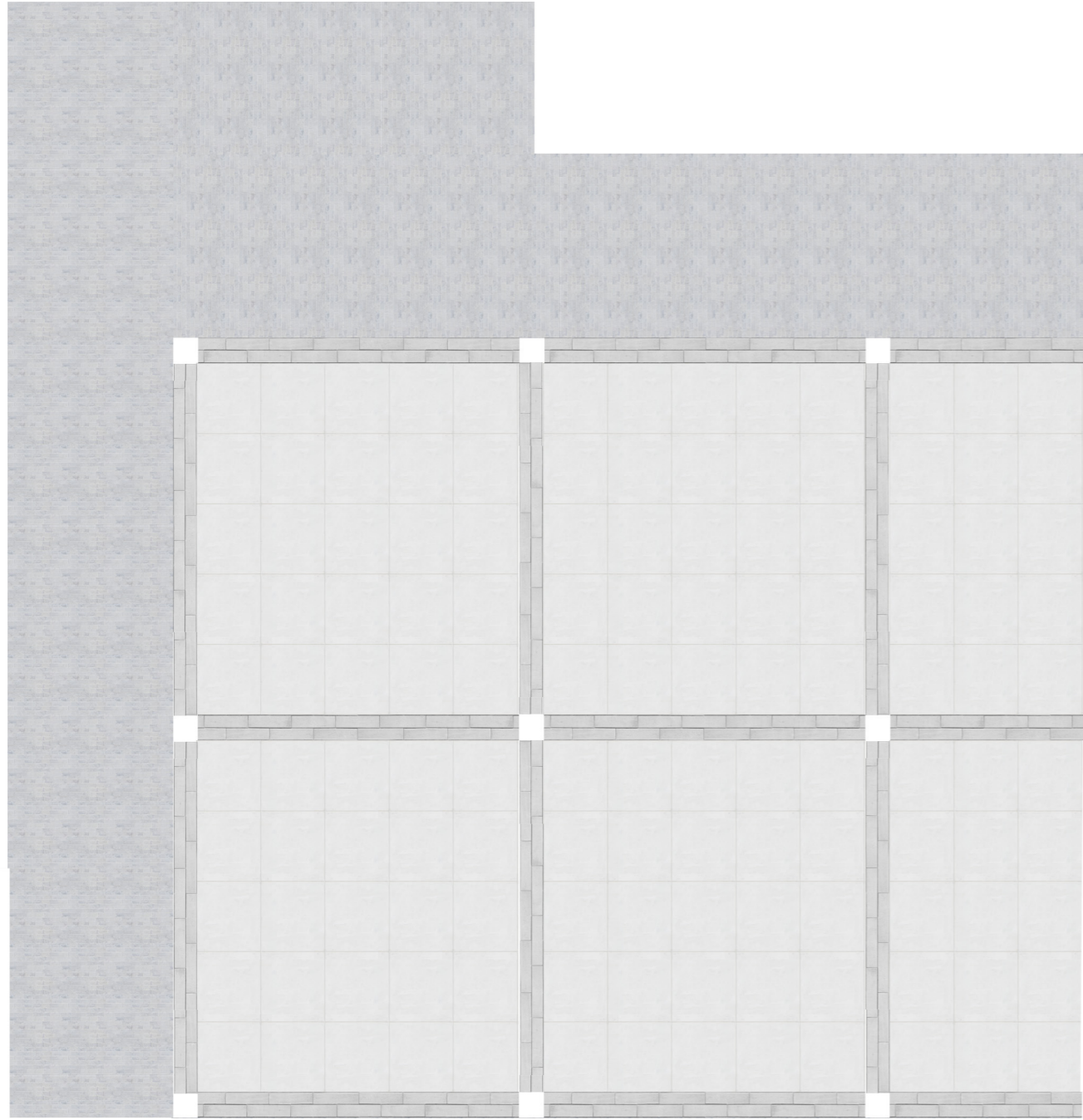

SPACE PLAN: EXPERIENCE FACADE



SPACE PLAN: EXPERIENCE FACADE

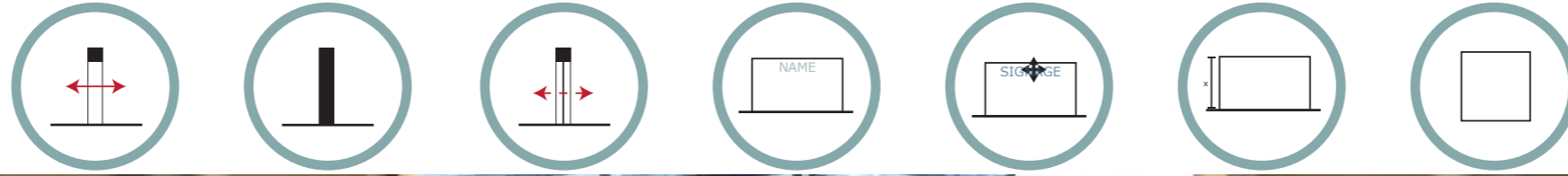

SPACE PLAN: MATERIALIZATION WALLS

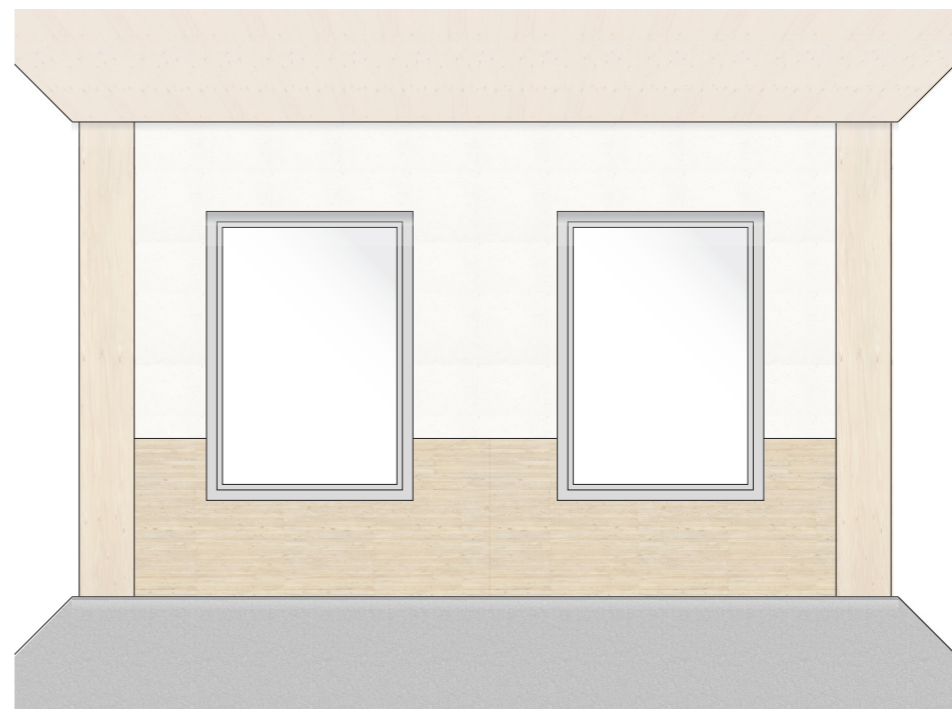

SPACE PLAN: FLEXIBILITY

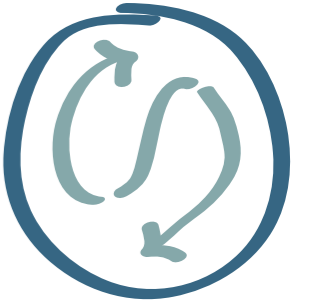

CURRENT GROUND FLOOR

CURRENT FIRST FLOOR

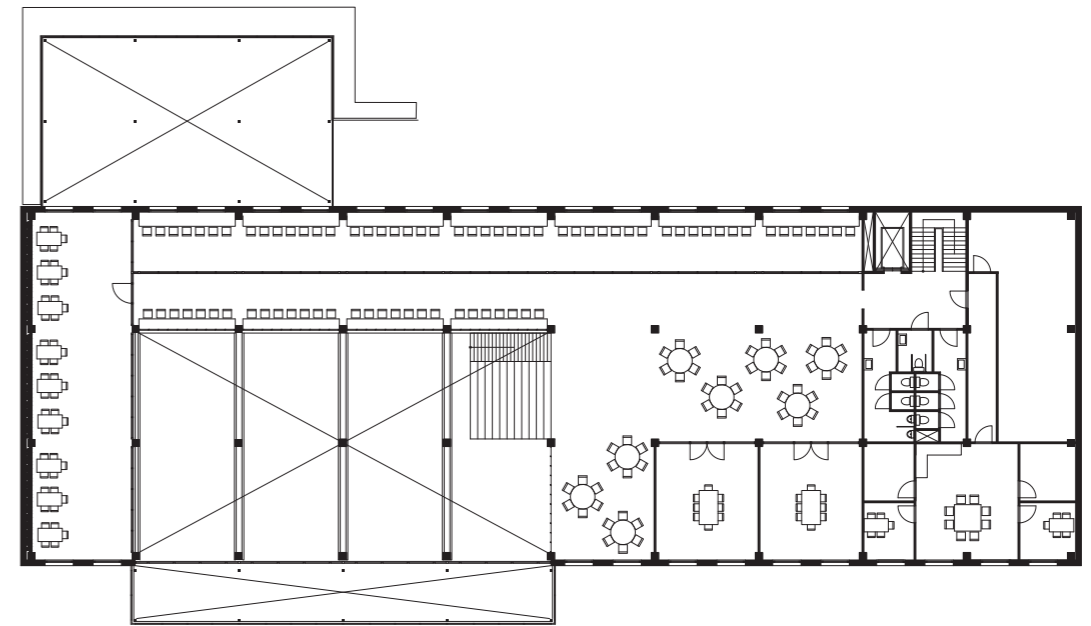
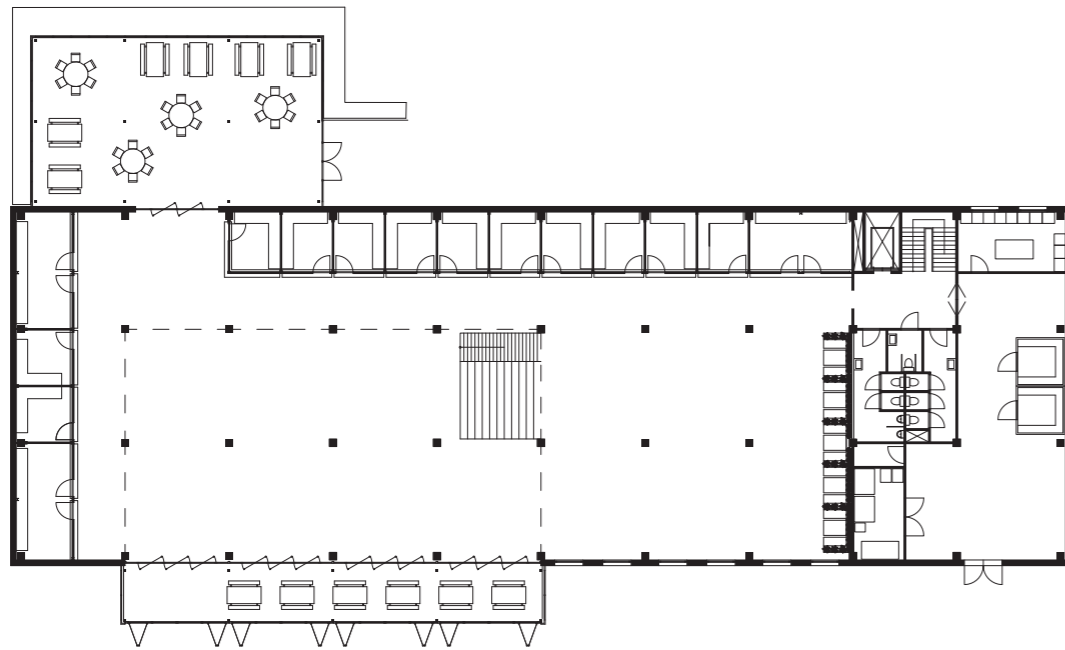

SPACE PLAN: FLEXIBILITY

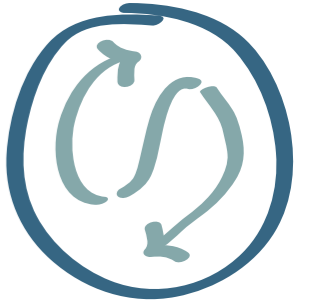

FUTURE GROUND FLOOR

FUTURE FIRST FLOOR

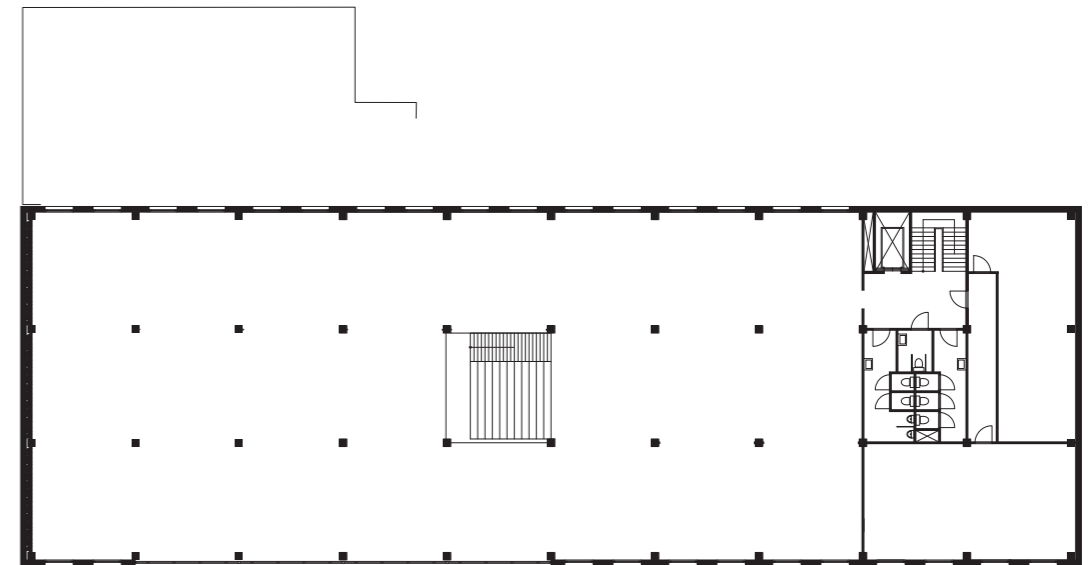
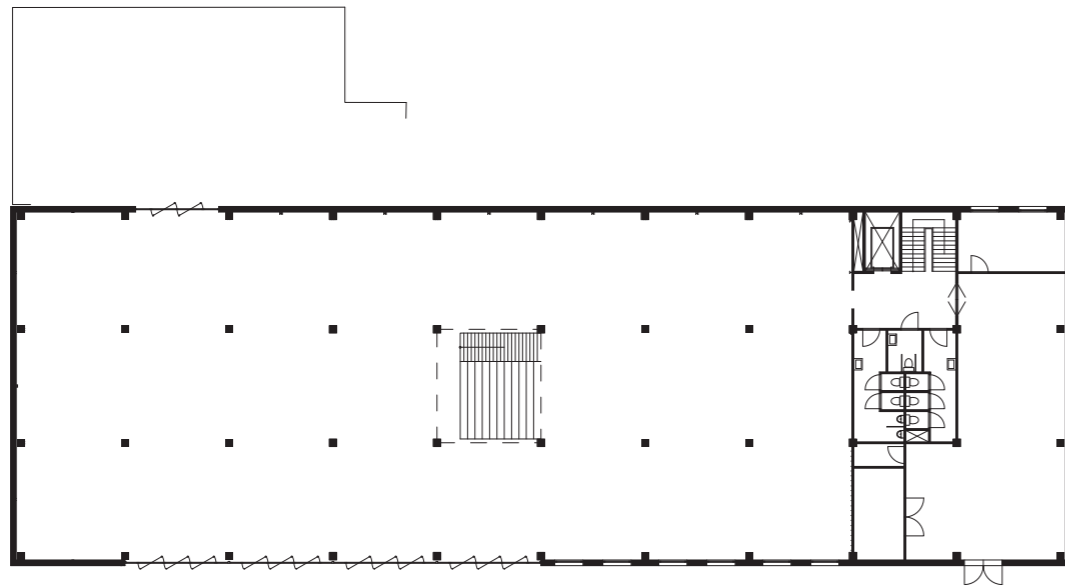

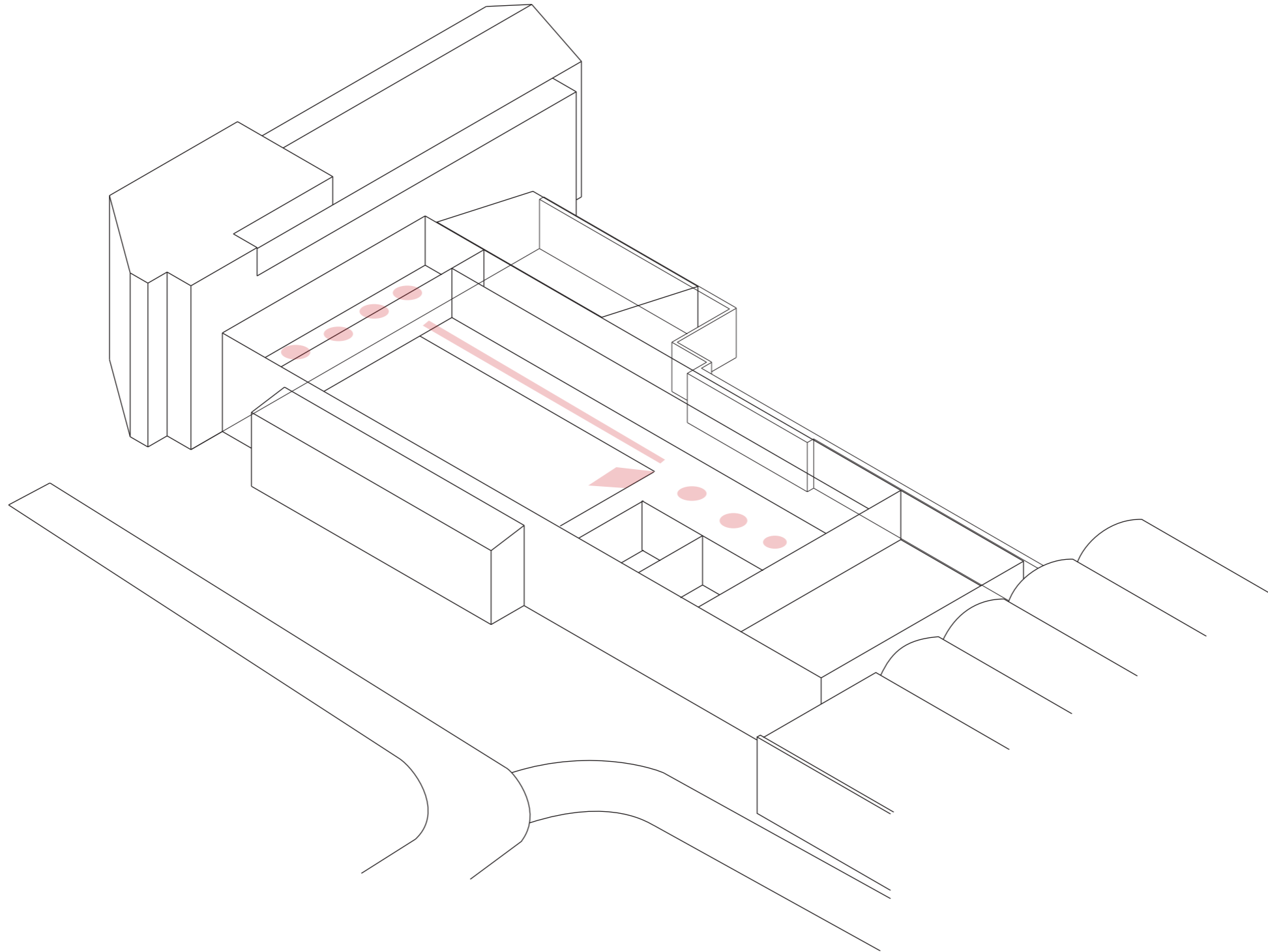

STUFF: SEATING FOODHALL



STUFF: EXPERIENCE OBJECTS

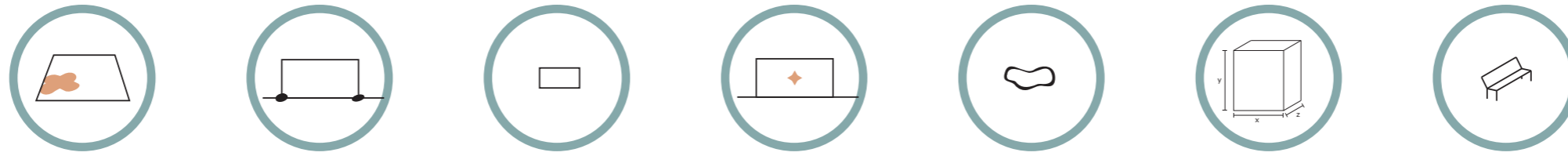

INTRODUCTION

RESEARCH

DESIGN

STUFF: SEATING WORKSPACES



STUFF: EXPERIENCE OBJECTS

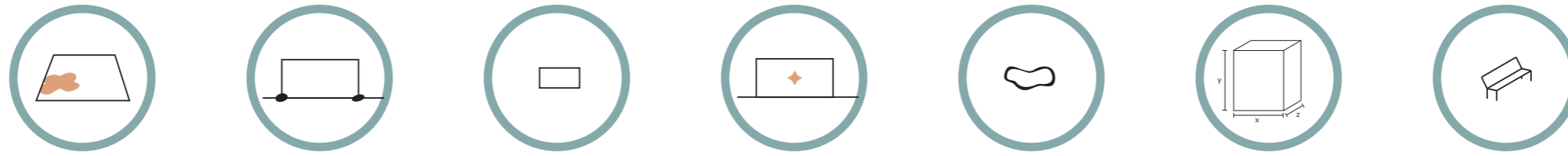

INTRODUCTION

RESEARCH

DESIGN

STUFF: GREENERY



STUFF: EXPERIENCE OBJECTS

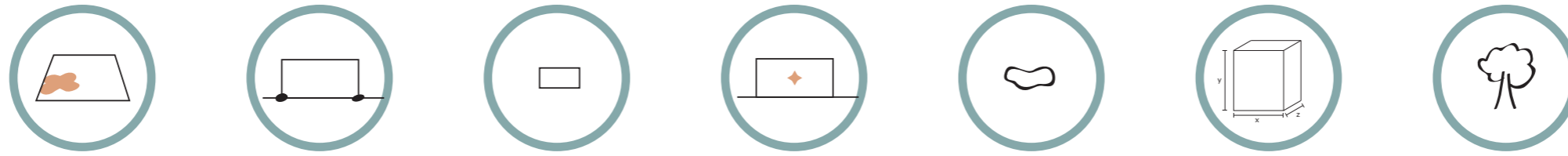

INTRODUCTION

RESEARCH

DESIGN

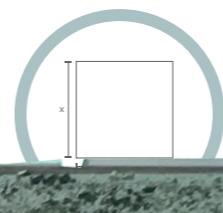
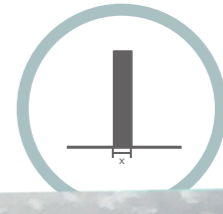
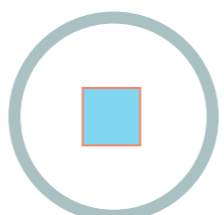
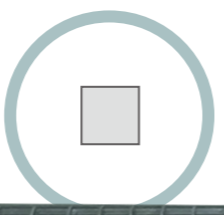
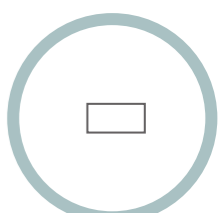
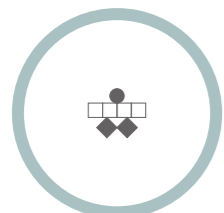
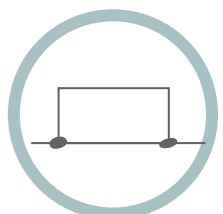
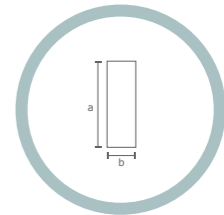
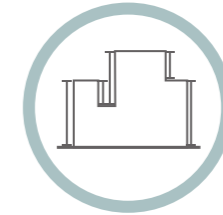
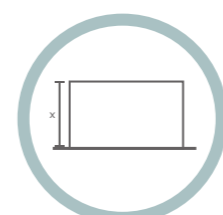
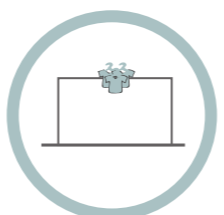
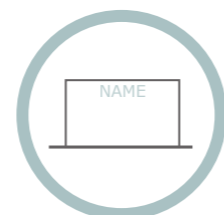
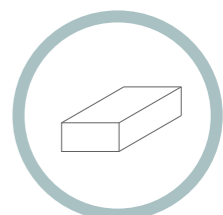
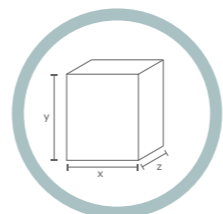
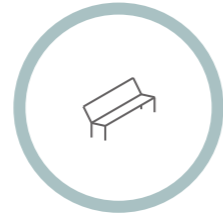
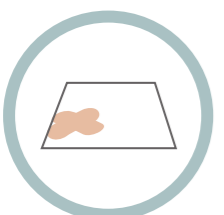
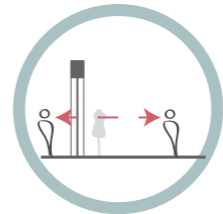
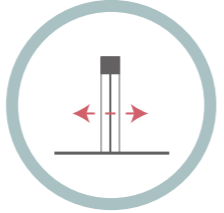
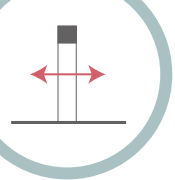



Let's
mEET



Let's
mEET

THANK YOU!