

A Military Satellite Terminal for S&F

B.J.J. Stijnen

To design and test a nationally owned satellite terminal to perform S&F operations

A Military Satellite Terminal for S&F

by

B.J.J. Stijnen

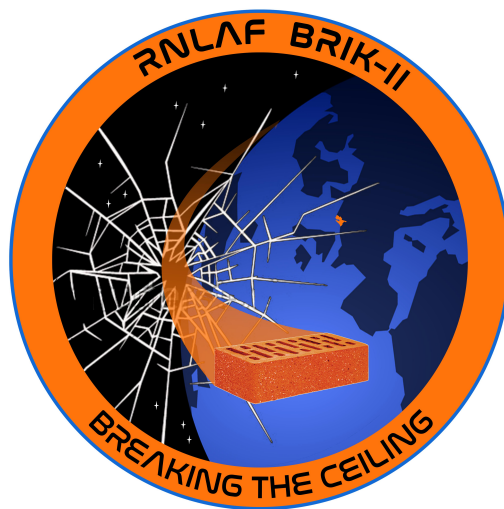

to obtain the degree of Master of Science
at the Delft University of Technology,
to be defended publicly on the 18th of June, 2018 at 9:00 AM.

Project duration: August 14, 2017 – June 18, 2018
Thesis committee: Dr. ir. E.J.O. Schrama, TU Delft, supervisor
Dr. ir. C.J.M. Verhoeven, TU Delft, supervisor
Maj. ir. J.B. Buijs, RNLAF, supervisor
Dr. S. Speretta, TU Delft
Dr. ir. B.C. Root, TU Delft

This thesis is confidential and cannot be made public. It is not allowed to copy or use information presented in this work. A non-confidential version will be made public in the repository from the first of October 2023.

An electronic, non-confidential version of this thesis is available at <http://repository.tudelft.nl/>.

Preface

The military use of space brings interesting challenges for both technology and operational aspects. The Netherlands armed forces are a small player within the military world. However, in 2013 the beginning of a space program was started by the Royal Netherlands Air Force (RNLAf). One of the key mission statements stated: "show the military relevance of Nano Satellites". A feasibility study was conducted and the realisation of the first satellite, the BRIK-II, was started. One of the payloads of this satellite is a store and forward system. In this thesis work a systems engineering approach towards, requirements definition, design, verification and testing is provided.

Special thanks goes to Ernst Schrama, Chris Verhoeven and Bernard Buijs, my supervisors from TU Delft and the RNLAf respectively. Especially I would like to thank Bernard for his confidences in my capabilities and for kick-starting my carrier. Furthermore I would like to thank Stefano Sperreta and Bart Root for taking the time to guide me during my thesis. Also thanks goes to all the members of the 982SQN and especially Jan Kooijman, who was very willing to share knowledge and experience. My friends Jochem and Rob for proof reading my thesis. For moral support I would like to thank my girlfriend Eveline de Jong and the rest of my family.

*B.J.J. Stijnen
Delft, May 2018*

Abstract

A Military Satellite Terminal for S&F

Author: Bas Stijnen

Student Number: 4191242

Email: B.J.J.Stijnen@student.TUdelft.nl

Satellite communication has been an important part of military operations for a long period of time. The Dutch MoD always used commercial assets or assets owned by partners to fulfill their communication needs. With the initiation of the BRIK-II project a small part of the MoD's communication need is going to be performed by a nationally owned space platform. In order to perform satellite communication in both urban and remote areas all over the world a portable, well functioning and easy to use ground segment needs to be designed. To get a better understanding of all the potential problems and challenges facing the design of such a terminal, a systems engineering approach is taken. The terminal is designed as one would design a spacecraft system: using requirements, a risk register, N2 chart, budgets and validation procedures.

Making use of commercially available components and open source simulation tools to design and test at subsystem level provides insight in expected performance. Furthermore it allows for prototyping software and visualising aspects like amplitude variation in Phase Shift Keying, selecting a power amplifier, and latency tests to determine a total data volume. The communications protocol that is envisioned from the start, is a simple automated repeat request scheme. This has a number of advantages; the sender will always be able to see if the message is delivered and the accommodation of multiple terminals is easier. A disadvantage is the maximal 2.87 Mbyte of data that can be transferred in a fixed time interval.

It is concluded that the design will fulfill most but not all requirements, the requirement on the data volume will not be complied with. The communication protocol that is chosen together with the limitations of some components make the transfer of 5Mbyte impossible. It is therefore recommended that further research to possible communication protocols is conducted. By making use of equipment that is already in the inventory of the SOF teams a light weight and low volume design could be realised. The terminal shall need further development and above all a satellite to communicate with, which will be launched in 2019.

Contents

1	Introduction	1
2	Mission Overview and Requirements Discovery	3
2.1	Functional Flow Diagram Nominal Operations	5
2.2	Functional Flow Diagram FF Mode	6
2.3	General Requirements	6
2.4	Environmental project tailoring process	8
2.4.1	Storage Phase	8
2.4.2	Transport Phase	8
2.4.3	Deployment Phase	9
2.4.4	Requirements specification	9
2.5	Technical Risk analysis	9
2.6	Space Weather	11
3	Design	13
3.1	Baseline Link Budget	14
3.2	Communications Protocol	18
3.3	Hardware Design	20
3.3.1	Antenna	21
3.3.2	Radio	22
3.3.3	CPU	24
3.3.4	Amplifier Design	25
3.3.5	Additional Components	26
3.4	Hardware Component Interaction	28
3.4.1	N2 Chart	28
3.4.2	Budgets	28
3.5	Software Design	30
3.5.1	Channel Synchronisation	31
3.5.2	GNU Radio Design	31
3.5.3	SGP4 Model	33
4	Requirements Verification	35
4.1	Multiple terminals in one footprint	35
4.2	Data rate	36
4.2.1	Modulation scheme	36
4.2.2	Spectral Efficiency	37
4.2.3	Time loss due to message handling	39
4.2.4	Link budget and Variable data rate	42
4.2.5	Actual data volume in one pass	45
4.3	Design verification and requirements check list	46
5	Test Setup and Results	49
5.1	Performance USRP Ettus Mini-i B505	49
5.2	Antenna Characteristics	52
5.2.1	Antenna Model	54
5.3	Receiver path test	57
5.3.1	Signal Recovery	57
5.3.2	Information decoding	61
6	Conclusion and Recommendations	63
6.1	Conclusion	63

6.2 Recommendations	65
A Appendix - I	67
B Appendix - II	69
C Appendix - III	71
D Appendix - IV	75
Bibliography	81

Abbreviations

982SQN	982 Squadron
ACK	Acknowledgement
ADC	Analogue Digital Conversion
AHP	Analytic Hierarchy Process
ARQ	Automated Repeat reQuest
AWGN	Additive White Gaussian Noise
BER	Bit Error Rate
BPSK	Binary Phase Shift Keying
C-LSK	Commandant Lucht Strijd Krachten
C2	Command and control
CW	Carrier Wave
DAC	Digital Analogue Conversion
dBic	gain in dB with respect to circular isotropic
DOT	Design Option Three
ESA	European Space Agency
ESM	Electronic Surveillance Measures
FF	Fire and Forget
FSK	Frequency Shift Keying
GEO	Geo stationary Orbit
GMSK	Gaussian Minimum Shift Keying
GRC	GNU Radio Companion
GUI	Graphical User Interface
HMI	Human Machine Interface
ITU	International Telecommunications Union
LEO	Low Earth Orbit
LSB	Least Significant Bit
MIMO	Multiple Input Multiple Output
MoD	Ministry of Defence
NATO	North Atlantic Treaty Organisation
OBC	OnBoard Computer
OOT	Out Of Tree
PSK	Phase Shift Keying
QPSK	Quadrature Phase Shift Keying
RNLAF	Royal Netherlands Air Force
RRS	Remote Radio Station
Rx	Receive path

S&F Store and Forward

SC Spacecraft

ScinMon Scintillation Monitor

SDR Software Defined Radio

SGP4 Simplified General Perturbation Satellite Orbit Model 4

SINAD It is the ratio of Signal+Noise+Distortion divided by Noise+Distortion

SitRep Situation Report

SOF Special Operations Force

TDP Thermal Design Power

TLE Two Line Element

Tx Transmit path

UHD USRP Hardware Driver

USRP® Universal Software Radio Peripheral



Introduction

With rapidly changing mission profiles, today's military users require ultra-portable, simple-to-use, highly reliable communication systems. In the past years the Netherlands Ministry of Defence (MoD) relied on the satellite communication services of NATO partners and of commercial services. Recently the 'Commandant der Lucht Strijdkrachten' (C-LSK) ordered to explore the use of nano-satellites for military purposes, as a direct result a feasibility study was conducted by the RNLAf in cooperation with the Delft University of Technology. This study forms the base of the RNLAf's own nano-Satellite (the Brik-II) which shall be launched by the beginning of 2019. Amongst several payloads it is equipped with a store and forward (S&F) subsystem which will function as a nationally owned mailbox. The goal of this mission is to explore the relevance of a nationally owned space based communication system within a relatively small budget. This thesis contains the preparatory work towards the design and construction of a small portable ground segment. This segment will enable special forces to transfer classified information via the S&F payload. In order to prove the relevance of this system a certain data volume will need to be transferred.

The BRIK-II mission is a 6 unit Cubesat [12] (6 times 10cm cubes) which will host several payloads. The multi-payload configuration is chosen to mitigate the risk of one payload failing. This mission will set the cornerstone for the future RNLAf space operations. The mission objective is to demonstrate the military relevance of small satellites. This mission is also initiated to gain knowledge and experience in satellite design and operations.

The RNLAf satellite mission BRIK-II is intended as a demonstration of this communication concept. It is not yet known to which extent the system will be used in real operations. Furthermore, not all end users have been identified. In addition to the RNLAf, users in the army, navy and military intelligence service could be granted access. These users will have their own requirements and preferred ground segment equipment. A certain degree of flexibility with regard to waveform, communication protocols and output power is thus desired on the part of the satellite hardware. For this reason a software controlled radio architecture is envisioned on the satellite. This will also allow for experience gained in the initial phase of the mission leading to expanded capabilities in a later phase through in flight upgrades to the On Board Computer (OBC). As a direct result of this flexibility the terminal will also have a SDR based architecture.

The concept of S&F dates back to 1957 and was first proposed by Brandon [4]. It was first flown on the Courier satellite in 1960 using on board tape recorders. S&F is a simple concept that could be compared to sending an email, only instead of using the internet to carry the message a satellite is used. A message is uploaded to the satellite via a terminal (somewhere on the planet) and is downloaded above the ground station (in the Netherlands). A single satellite in a low earth polar orbit can provide near global coverage on a daily basis. Compared to GEO stationary orbits where there is continuous coverage over a part of the planet. A Low Earth Orbit (LEO) is located between 300 and 2000 km altitude, where the received signal power is good enough for small terminals and the signal delay is less compared to GEO satellites. A disadvantage of this type of orbit is

the limited contact time and the relative speed between the terminal and satellite.

In order to narrow the scope of this project the focus will be towards a portable system for special forces on foot. During a reconnaissance mission a squad of marines can only carry lightweight equipment, the location and date of their mission is mostly classified and they should be able to rapidly deploy a ground station. From these operational needs, technical requirements can be derived. The system shall be light weight and fits easily in a backpack. The station should be robust and have a minimum impact on 'the mission'. In this portable antenna systems there are a number of design challenges:

- Stand alone operations
- Antenna size [6]
- Up- and down-link link-budget
- Operating in a military environment

From the 'S&F use case' presented in chapter two the following objective is derived:

To design a portable, low cost and easy to use terminal, able to perform up-downlink of a 5Mbyte file to a LEO orbiting satellite

A typical SOF team consists of several specialists among which a communication specialist. The communication specialists is trained to operate different communications systems and perform small reparations if necessary. The specialists is experienced in these kind of operations and is able to understand concepts like signal attenuation and link budget. This terminal should be an addition to his or hers arsenal of high-tech communication devices.

A systems engineering approach towards designing is used in this report. In chapter two a mission overview and requirements discovery will be discussed. This will set the scene for the design which is presented in chapter three. Chapter four will test this design against the requirements and will furthermore contain a thorough investigation on the data volume. In Chapter five the conducted antenna tests and software tests will be discussed, this chapter will also contain a discussion on the durability limit of TLE information with respect to the specific envisioned satellite orbit and antenna used. A conclusion and corresponding recommendations will be presented in chapter 6.

2

Mission Overview and Requirements Discovery

This thesis report covers part of one of three payloads of the BRIK-II mission. The BRIK-II carries three payloads; a multi-needle-Langmuir probe (ScinMon), an Elint sensor (ESM) and a Store and Forward (S&F). There are three payloads to mitigate the risk of mission failure due to a failing function. This satellite should set the corner stone for the space endeavours of the RNLAf. The journey towards experience and knowledge about satellite design and operations resulted in the following mission objective of the BRIK-II.

BRIK-II mission statement:

To show the military relevance of Nano Satellites.

The S&F payload has its own mission objective, partly because it is a separate satellite function and partly because it is developed by the 982SQN in Dongen. The RNLAf does not only want to demonstrate military relevance. A secondary objective is to learn and gain experience in satellite development and operations. To gain experience means to participate and therefore the 982SQN will develop its own payload, having the RNLAf as its main stakeholder. This has led to the following objective.

S&F system objective:

The S&F payload shall be able to relay a file containing text, imagery or other between terminal and ground station.

In short the S&F mission is to pick up or deliver a message from somewhere in the world, originating from or to be delivered to the ground station in the Netherlands. The location of the terminal is not known to the satellite. It should be possible to accommodate multiple terminals in the same satellite footprint. This leads to several types of applications, from terminals on embassies, inside submarine buoys, reconnaissance missions behind enemy lines, on board ships, on a main or forward operating base, asset management and many more. In order to reduce the complexity of the design a use case is defined. In this report a design is made for special forces travelling on foot, performing a reconnaissance mission behind enemy lines. Special forces normally travelling on foot in teams of 4 to 6 or alone. Sometimes operating in remote locations sometimes in densely populated areas resulting in the following mission objective.

Terminal objective:

To design a portable, low cost and easy to use terminal, able to perform up-downlink of a 5Mbyte file to a LEO orbiting satellite

The use case as written by the kap. M. Noppen of Bureau Space CLSK.

Scenario Baseline

SOF operate in an isolated C2 environment not accessible to other departments of the Ministry of Defence, this includes the office controlling and commanding the satellite payload. This affects how the payload needs to function since information on the location and time of a SOF operation will be unknown. SOF are trained to be able to operate in an arbitrary environment at any place in the world, the payload should support this.

Considering this, the following paragraphs describe how the SOF unit is envisioned to use the payload in their environment.

Sending a data package to the satellite

The SOF are on a mission in Afghanistan (or any other location) to collect intelligence. The mission is planned to take 5 days when all goes well. One part of the mission planning is that the unit will give a situation report (SitRep) at most every 24hrs on the status of the mission (text) and if available send (parts of the) acquired intelligence (e.g. photos) to the Homebase. After being in the field for almost a day it is time to send a first SitRep to the Homebase. The operator takes out the terminal and checks on the display when the next few passes of the satellite will be (latest TLE was loaded at the compound) and how long these will be. The terminal calculates the maximum file size with margin (taking his direct geographic environment in account) that could be sent for each of the coming satellite passes. The operator can then tailor his data package to the maximum size of the coming pass or decide to wait for a better pass if he wants to send a bigger file. This is for the operator to decide on. If the file size is bigger than what is possible for even the best passes then the operator needs to split his file, since the satellite will not merge data files over multiple passes. After this the operator aims the antenna of the terminal in the correct direction and waits for the satellite to come over the horizon. Shortly before the satellites arrival is expected the terminal starts transmitting to let the satellite know it wants to send a file. The moment the satellite picks up the terminal signal it confirms that it is ready to receive or that the terminal has to wait because there might be more terminals in the direct environment. Also it might be that the S&F wants to send a file to the terminal first, before receiving a file back. This information is built in to the confirmation that the satellite sends to the terminal. Prioritising/access management is done by the payload (onboard the satellite). In this case the SOF team operates the only terminal in the environment so the satellite confirms that the terminal may start sending. The terminal starts sending its file and after a predefined time the transmission is completed and the satellite confirms to the terminal that the file has been received in good order. The operator of the terminal packs the antenna and continues his mission. The file sent to the S&F holds meta data on to whom to downlink the message. Also the satellite can send information to a terminal that a previously uplinked message by that terminal has been delivered in good order. Obviously the terminal needs to be deployed for that case.

SOF receiving a data package from the satellite

The SOF situation is as described above only now the homebase has uplinked a file to the S&F addressed to the SOF team in the field. The message contains information with renewed positions of adversaries.

12 hours after the last time the SOF team transmitted their SitRep the operator sets up the antenna of the terminal because he saw on the terminal that a satellite pass will occur in the next 10 minutes. The operator has no knowledge of whether there is message in the mailbox for him but can decide to check on this (the same as walking to your regular mailbox). After setting up the terminal it starts signalling shortly before the satellite comes over the horizon to let the satellite know it is there. The satellite confirms that it is receiving the terminal and lets it know that it will downlink a message. Next the terminal switches to receiving and the satellite starts transmitting the file, after which the terminal confirms it has received the file in good order. There is no file to uplink so the operator packs the terminal and continues his mission.

Fire and forget The position of the SOF team is vulnerable and intelligence tells that adversaries have measures to locate transmitters in the direct environment. Because of this the C2 department on the compound decides that it will send a fire and forget (FF) message to the SOF team. Via the terminal on the compound a file is uplinked to the satellite together with information on where and how long the file has to be downlinked. When the satellite is in the area of interest it sends out the message for as long as it is in reach of this area (also depending on other activities in this area).

The operator of the SOF team can decide to set up the terminal without the knowledge of whether there is a message waiting (just checking the mailbox) and sets the terminal to listen mode so that it only listens for the satellite, nothing is transmitted by the terminal (no channel synchronisation). The terminal notices the fire and forget message and starts receiving it without sending (intermediate) confirmations or requests back up to the satellite. After receiving the file the operator packs the terminal and continues his mission.

the message can be sent in one of the coming passes taking in to account the time of passage and battery level. Before the satellite is in view the user is notified to deploy the antenna system. Once the satellite is in view the terminal will listen if there is any activity on the satellite (it could be dealing with another terminal/ground station). The satellite will be able to manage several terminals but only one at a time. In case there is activity the terminal shall notify the user (3). If the terminal knows the satellite is in view and there is no activity observed, it will start initiating a link. After carrier synchronisation, information on the 'to be sent' file or 'to be received' file will be exchanged. Furthermore, the satellite will give an updated version of its TLE. The terminal is normally ready for operations, if something went wrong during the initial information exchange it will notify the user (4). The satellite will inform the terminal if it can send a file or if it should stand by to receive a message. From here the communication protocol starts, in diagram 2.1 an Automated Repeat reQuest (ARQ) is envisioned. In ARQ the message is divided in data blocks, each block is sent and answered this way. Blocks containing an error can be repeated on request. This is a form of error control used in wired and wireless communication systems [15].

2.2. Functional Flow Diagram FF Mode

In this section a functional flow of the terminal with respect to the Fire and Forget (FF) mode is described. When in FF the terminal only listens to the satellite, there is no backwards communication. When using Fire and Forget no error correction through ARQ is possible.

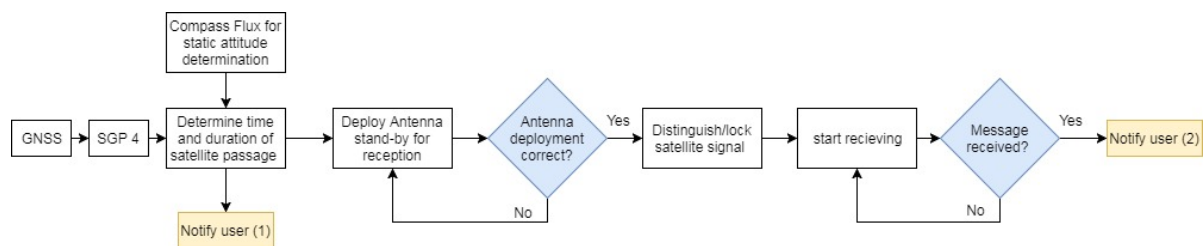

Figure 2.2: Terminal Functional Flow Diagram fire and forget

In fig: 2.2 the FF is a simple listening mode. The terminal knows when the satellite will pass, the user puts the terminal in (FF) mode and point towards the satellite. After the message is received the user is notified (2) and the terminal can be packed. The Terminal knows if the end of message command is received. Since the FF mode only allows space to ground communication a different error control technique will be used. Forward Error Correction (FEC) could provide a possible solution.

2.3. General Requirements

In this section a review of the requirements will be presented, the operational requirements as given by the RNLAf are presented. Requirement number is part of the overall BRIK-II system requirements tree. Only the top level operational requirements concerning the mobile ground station are presented here.

Table 2.1: Terminal Requirements (1)

Req number	Requirement description
BRK-SYS-RRS-011	The terminal shall have a mass no more than 10Kg
	In order to make the system portable an upper boundary on the systems mass of 10 kg is given. This includes all required equipment for the system to be operational.
BRK-SYS-RRS-012	The terminal shall fit within a volume of 20 L
	In order to make the system portable a maximum volume of 20L is given. This includes all required equipment for the system to be operational.
BRK-SYS-RRS-021	The terminal shall be able to establish a robust up and downlink
	A robust up and downlink means that in case of a disconnection the system will be able to carry out the file transfer regardless. If there is not sufficient time left to do this the system will inform the user.
BRK-SYS-RRS-022	The terminal shall accommodate operation by a novice user
	The system shall have a simple HMI, the user should be able to operate the system without having knowledge of orbital mechanics, waveforms, antenna types etc. Furthermore no hand calculations should be performed on the file size vs contact time. This should all be calculated by the terminal.
BRK-SYS-RRS-023	The terminal shall be able to operate on battery power for at least 100 min
	The terminal should be able to operate in the field without access to the power grid. In the ConOps document it stated that during a five day mission daily contact should be established via the SF system. This would result in a 100min of battery power at least.
BRK-SYS-RRS-024	The terminal shall be flexible with respect to waveform and transmit power
	The terminal shall be able to change the waveform, in order to improve the system while operational. Since this will be a demonstrator and thus some development will be needed. Same holds for the transmit power, more data throughput will result in more transmit power. However the user will be pleased with as less power transmitted as possible for various reasons.
BRK-SYS-RRS-025	The terminal shall have a small radiation footprint
	One of the requirements coming from a potential user. Obviously because of the possibility to be located or to be eavesdropped.
BRK-SYS-RRS-026	The terminal shall facilitate the writing of an intel report/provide an interface to uplink an externally written report
	In order to provide the terminal with the message content. This can either be a small laptop like device or a usb like port.
BRK-SF-SYS-001	The SF system shall be able to relay (receive and store, or retrieve and send) an intel report of at least 5.0 MegaByte [TBC] of data during a single pass
	It should be possible to send or receive a data-package of at least 5.0 MegaBytes. During the design phase a study will be conducted towards the achievable data volume.
BRK-SYS-RRS-033	The terminal shall accommodate a message storage of at least 128Mbyte(TBC)
	The terminal should be able to store messages received from the satellite on its internal memory. It should also be able to accommodate message backup storage. It is foreseen that 128 Mbyte will suffice.
BRK-SYS-RRS-034	The terminal shall be able to provide information to the user on possible message transfer windows.
	The operator should be capable of planning his mission ahead. The terminal will inform the user on the time of contact, duration and possible file size that can be transmitted in this window. This allows the operator to adjust his or her file size, if needed.
BRK-SYS-RRS-035	The terminal shall work at a minimum elevation angle of 10 degrees
	This implies that an RRS should be able to contact the SF payload if the satellite is at a minimum elevation of 10 degrees. This value originates from a preliminary satellite antenna pattern
BRK-SF-SYS-014	The SF system shall distinguish between desired and undesired messages/signals
	Imagine this as a 'man in the middle', someone is recording the message being sent and repeatedly sends it to the satellite. This causes the satellite to be filled with 'undesired' messages. That way this message is an undesired message but a desired signal. That is why the SF payload should detect and ignore these messages.

Table 2.2: Terminal Requirements(2)

BRK-SYS-RRS-042	The SF system shall accommodate the ability to communicate with multiple RRSs/GS located in the same footprint
	The situation that more RRS are deployed in the same footprint of the satellites antenna is likely to happen since this footprint is relatively large. Therefore the RRS and satellite should be able to deal with this situation.
BRK-CON-007	The SF system shall comply to the ITU regulations and relevant recommendations
	The ITU imposes constrains on all radiative elements in order to prevent undesired interference.
BRK-SF-SYS-061	The SF system shall work in allocated frequencies for uplink 312MHz-322MHz
	Available uplink frequency range for NATO UHF users. Within this frequency range a channel will be allocated for this project
BRK-SF-SYS-062	The SF system shall work in allocated frequencies for downlink 267MHz-273MHz
	Available downlink frequency range for NATO UHF users. Within this frequency range a channel will be allocated for this project
BRK-SF-SYS-063	The SF system up- and downlink shall have a bandwidth of 25kHz
	This is the maximum channel bandwidth of a NATO UHF channel.

In table 2.1 and 2.2 the general requirements are presented and assigned a requirement number. Each number contains information of the requirements origin and level, they all start with BRK indicating the name of the overall project (BRIK-II). All requirements containing RRS are terminal specific requirements. Requirements containing SF-SYS are S&F system requirements. Numbers containing CON originate from the general BRIK-II communications requirements.

2.4. Environmental project tailoring process

Military equipment needs to comply with strict standards and must undergo a series of predefined tests. These requirements and test are documented in MIL-STD-810-F, which comprises out of a number of 'sub' documents. These sub-documents are written in a general way, so the applicable sections need to be distilled. In order to do so, three life phases and corresponding requirements are identified. The three phases are storage, transport and operational.

2.4.1. Storage Phase

Storage will take place in a climate controlled depot. Since there are no restrictions on temperature, pressure, humidity etc. The only event that need to be accounted for are:

- Shock due to handling

2.4.2. Transport Phase

Transport will take place over land using wheeled vehicles and man packed. As well as through air using fixed wing and rotary aircraft. During transport the system will be stored in a protective cover. Therefore solar radiation, vehicle vibration, snow, hail, dust and immersion will not be taken into account during transport. The events that are of interest during the requirements discovery are:

- Hi/low temperatures
- Dry/humid
- Shock due to road surface and handling
- EM radiation
- Electrostatic discharge
- Reduced pressure
- Rapid pressure change
- Rapid temperature change
- High temperature in glassed enclosures.

2.4.3. Deployment Phase

During deployment the system will be outside the protective cover for a limited time per day, extra events from which requirements are derived on top of the requirements during transport phase are listed below.

- Mud

Planning is required when using this device, it is meant to transfer strategical information rather than tactical (time sensitive information). Therefore shock due to weapons fire is not taken into account.

2.4.4. Requirements specification

In table 2.3 an overview of the requirement specification can be seen.

Table 2.3: Environmental tailoring requirements

Condition	Requirement	Comment
Hi/low temperatures Basic hot A1 +44°C Basic cold C1 -33°C	AECTP 300 [17]	Method 301 procedure II, III
Dry/Humid Basic hot A1 +44°C Basic cold C1 -33°C	AECTP 300 [17]	Method 301 procedure II, III
Rain, hail, etc.	IP65	
Shock/vibration man mounted	AECTP-400 [18], Method 414	RRS likely to be in protective cover.
Shock due to road surface and handling	Drop test /loose cargo AECTP 400[18] (Edition 3) ANNEX A 406	Drop test without protective cover Loose cargo: RRS likely to be in protective cover.
EM radiation	NCE03 NCS04 NRE02 NRS03 NRS04 [19]	Conducted Emission due antenna terminal Antenna port, rejection of undesired signals Radiated emission, electric field Radiated Susceptibility, Transient electromagnetic field Radiated Susceptibility, Magnetic field susceptibility
Electrostatic discharge	NCS12-2 [19]	Category 501
Reduced pressure	Leaflet 236/237/1 [16]	Method 312
Rapid pressure change	Leaflet 236/237/1 [16]	Pressure change during free fall
Rapid temperature change	Leaflet 236/237/1 [16]	Temperature change during free fall Temperature change conditioned area -ambient temperature
High temperature in glassed enclosures.	Temp.above 85°C. LEAFLET 234/1 2.1 .d	In this case the terminal is not operational; no internal heat is generated. System likely to be in protective cover.
Mud	IP65	

2.5. Technical Risk analysis

To identify possible challenges or problems a risk register is constructed which is presented in this section. The risk register will only contain the technical risks. In the technical risk assessment no programmatic risks

are included. These programmatic risks are identified but will not be published and are for internal use only. In table 2.5 a register of all the identified risks is listed including the strategy to cope with the risk. These risks are plotted in a risk map, table 2.4, this gives the relation between the Likelihood of occurrence versus the consequence of the risk. Four different strategies to cope with a risk are listed below:

- Mitigation - A risk is mitigated by applying methods to eliminate or reduce its likelihood or consequences
- Acceptation - The project manager accepts the risk and documents the rationale
- Research - This alternative includes collecting additional information and doing analyses to refine likelihood and consequences estimates, and sometimes, to reduce the uncertainty surrounding these estimates.
- Watch - Decision to not take immediate action but to track monitor and document the changes over time.

In a risk map the green areas indicate the low risk low consequence risks, ideally all risks should be mitigated to the green area. Orange indicates the medium risk, consequence area. The area in red represents the unacceptable region.

Table 2.4: Risk Map

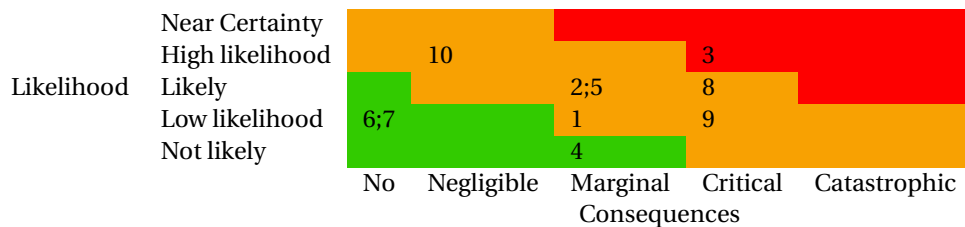

In table 2.5 a register of the identified risks is listed. The first column refers to the number of the risk in the risk map (table 2.4). in the second column the risk project number is displayed, the third column holds the mitigation strategy. The last column contains a short risk description. [13]

Table 2.5: Risk register

Rank and tread	Approach	Risk Title	
1	BRK-R-RRS-001	M	Subsystem (component) failure
2	BRK-R-RRS-002	R,M	Connection (interface) failure
3	BRK-R-RRS-003	R	Message transfer failure
4	BRK-R-RRS-004	A,R	Communication window definition failure
5	BRK-R-RRS-005	W,R	Structural failure due to operational environment
6	BRK-R-RRS-006	W,R	structural failure due to manufacturing defects
7	BRK-R-RRS-007	W,R	Structural failure due to environmental effects
8	BRK-R-RRS-008	R,W	Software failure
9	BRK-R-RRS-009	M	Loss of system by dividing in multiple parts
10	BRK-R-RRS-010	A, M,W	Loss of power/connector

Per risk a small description on the mitigation will be given below, this description will furthermore contain an explanation on its position in the risk map.

BRK-R-RRS-001

This risk is mitigated by using qualified components, based on experience of the 982SQN and manufacturer specifications. Since COTS components are used the risk on component failure is low

BRK-R-RRS-002

The interface risk is also mitigated by using qualified cables, connectors, enclosures and adhesive methods. For some interfaces research is required, again experience of the 982SQN has contributed to risk mitigation.

BRK-R-RRS-003

A message transfer failure will be researched and analysed, because there is hardly any experience at 982 SQN with respect to communications with LEO satellites. Therefore, this is the highest risk, no message transfer means mission failure. In order to minimise this risk within the project extensive testing will be done.

BRK-R-RRS-004

Communication window definition is done by using the SGP4 orbital prediction model, qualified software is used to implement in the design. There is only a small risk that this is wrongly interpreted by the control software or the user. Furthermore, extensive testing can be done at low cost.

BRK-R-RRS-005

Structural failure due to the operational environment is mitigated due to the strict requirements posed by the MIL-STD specifications. There is also experience within the 982SQN to design and test equipment that comply with these standards.

BRK-R-RRS-006

Structural failure due to manufacturing defects; the system will be composed of COTS components which will have operational heritage. Therefore, this risk can be mitigated. If there are any components that will be tailor made for this system extensive testing, on the specific part will be done.

BRK-R-RRS-007

Same reasoning as for BRK-R-RRS-005, both the storage environment and transport environment are described in the requirements.

BRK-R-RRS-008

Software failure, this contains terminal control software, HMI software and radio/functional software. Extensive testing is required in order to reduce the risk on the developed software. There is limited experience within in 982SQN in this field.

BRK-R-RRS-009

This risk is only relevant if the system is designed such, that parts are divided. It is foreseen that the terminal will be modular with respect to the antenna used, power source used and different ways to enter you message. Due to the modularity several components can be replaced.

BRK-R-RRS-010

A loss of power during operation results in immediate failure, this is mitigated by having a battery and a separate power connector. A contingency battery is not foreseen in the design.

2.6. Space Weather

During the feasibility phase of the BRIK-II project, a proposal was made. It concerned a setup for the measurement of scintillation effects on UHF satellite communication in the NATO band. What makes this setup so special is that the satellite has a multi-needle-langmuire-probe instrument for measuring electron density in the ionosphere. This could be correlated with the disturbance measured in this specific communication channel to expand the knowledge of signal scintillation effects. A portable terminal would be a quick and easy way of conducting measurements in equatorial and polar regions. This is an interesting research project but outside the scope of this thesis.

3

Design

In this chapter the design will be summarised. First a baseline link budget and message handling concept will be presented, which provides a good starting point in addition to the system requirements. The second section deals with the actual message handling and provides a preliminary estimation of the data throughput. In section three the main system components are identified and discussed, an extra sub section is added to deal with remaining support hardware. The fourth section deals with the software design. Two terminal concepts are presented in figure 3.1 and 3.2 . These concepts are drafts and represent a starting point of the design as which to iterate from. These images do not represent the final product.

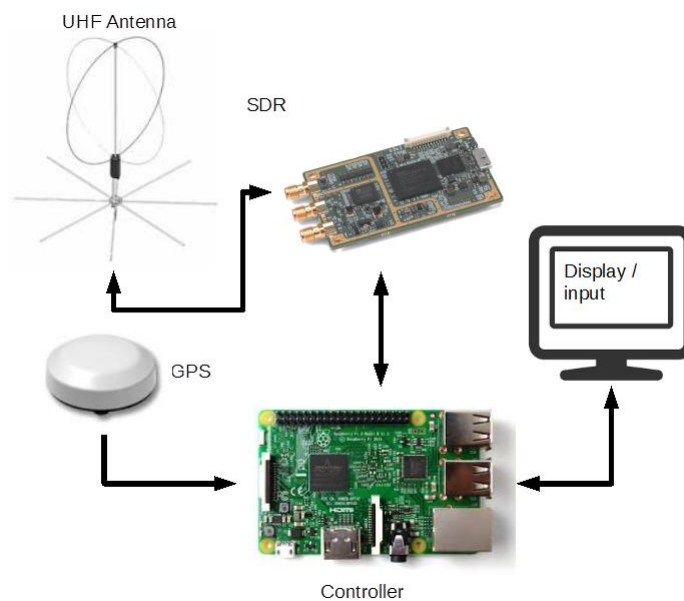

Figure 3.1: Initial draft design concept

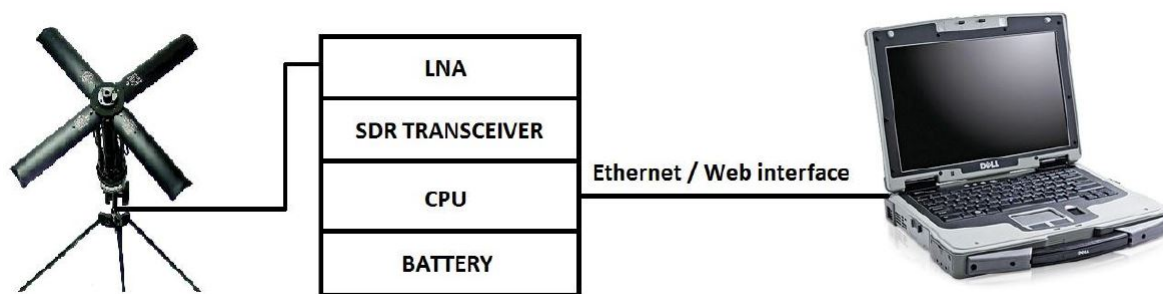

Figure 3.2: Iteration on initial draft design concept

Concept one shows a simple layout using COTS components, an omni-directional antenna, an SDR, a credit card sized computer and a display. In order to determine its location it uses a GPS sensor. Concept two is slightly different, here the terminal consists of a block containing a CPU, SDR and an amplifier. This concept uses the antenna and laptop of a different application.

A similarity in both concepts is the use of the antenna for both Rx and Tx, furthermore they both use a SDR and have a CPU (or internal computer). These components shall play a central roll in the design and component selection. The difference between these concepts is the use of a directional antenna versus a omni-directional antenna, a link budget investigation will determine if the zero dB antenna can be used. The concepts form the starting point of the design.

3.1. Baseline Link Budget

Before the design breakdown and component selection is done, it is important to investigate the frequency channel, bandwidth and the to-be-sent data volume. A starting point in this investigation is the Shannon–Hartley theorem presented in equation 3.1 [8] gives the theoretical channel capacity as function of the signal to noise ratio (S/N) and the channel Bandwidth.

$$C = B \cdot \text{Log}_2 \left(1 + \frac{S}{N} \right) \quad (3.1)$$

In this equation C is the channel capacity in Bits/s, B is the bandwidth and S/N is the signal to noise ratio of the channel.

- The Bandwidth limits how fast information can be sent.
- The S/N limits how much information can be squeezed in each transmitted symbol.

The Bandwidth is determined by the available channels within the NATO frequency policy and set by BRK-SF-SYS-007 at 25kHz. This means that changes in the data rate should be achieved by increasing the S/N since the bandwidth is fixed. In table 3.1 an indication of the theoretically achievable data rate is given, according to equation 3.1.

Table 3.1: Theoretical Channel Capacity for 25kHz Bandwidth

S/N [dB]	6	9	12
C [Bits/s]	$7 \cdot 10^4$	$8.3 \cdot 10^4$	$9.3 \cdot 10^4$
η [Bits/Hz/s]	2.8	3.3	3.7

In order to comply with requirement BRK-SF-SYS-004 a bit rate of at least $6.7 \cdot 10^4$ bits/s should be achieved, assuming a pass of 10 min and assuming the entire bandwidth can be used to write data on. From the channel capacity C the theoretical spectral efficiency (η) can be calculated in Bits/Hz/s using equation 3.2 and is displayed in the bottom row of table 3.1. Several modulation techniques can be used to achieve these kinds

of efficiency's. However the S/N ratio will have the most significant impact and is the only parameter that can be tweaked, by calculating a preliminary link budget a baseline will be established. Due to the nature of satellite orbits the S/N is not a fixed value, it will vary per pass and during a pass, in order to make a prediction the SGP4 [23] model will be used.

$$\eta = \frac{C}{B} \tag{3.2}$$

A link budget is always calculated using two ends of a communication system and everything in between. Since the space craft and the terminal still have to be designed this preliminary calculation is based on the assumptions listed below:

- SC uses a 0 dB antenna
- Polarisation loss is estimated to be 3dB (but can range form 0 to 20)
- Circuit induced noise is 0.9 dB
- Multi-path propagation loss is 2 dB
- System noise (kTB) is -156.8dB
- Transmit power of the satellite is 1 W
- Transmit power on the terminal side is 5 W

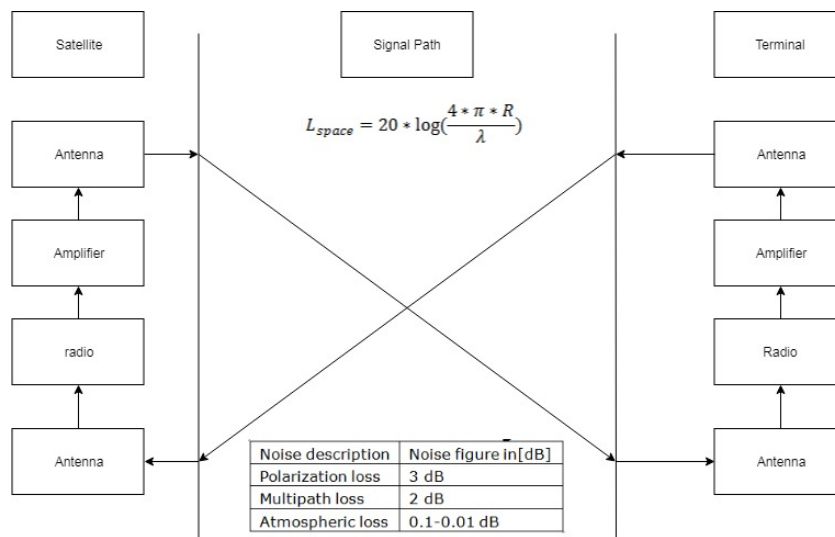

Figure 3.3: Graphical representation of the link budget

In figure 3.3 a graphical representation of the principle of a link budget is shown. for example starting at the Tx radio going to Rx radio . The arrow can be followed, in the amplifier and antenna gain will be added to the signal. During the transfer, path loss will be subtracted together with all other losses. The complete link budget is given in equation 3.3 .

$$\frac{E_b}{N_0} = P_{EIRP_{dBm}} - L_{FS_{dB}} + G_{AR_{dB}} - L_{P_{dB}} - L_{m_{dB}} - L_A - (kTB)_{dB} \tag{3.3}$$

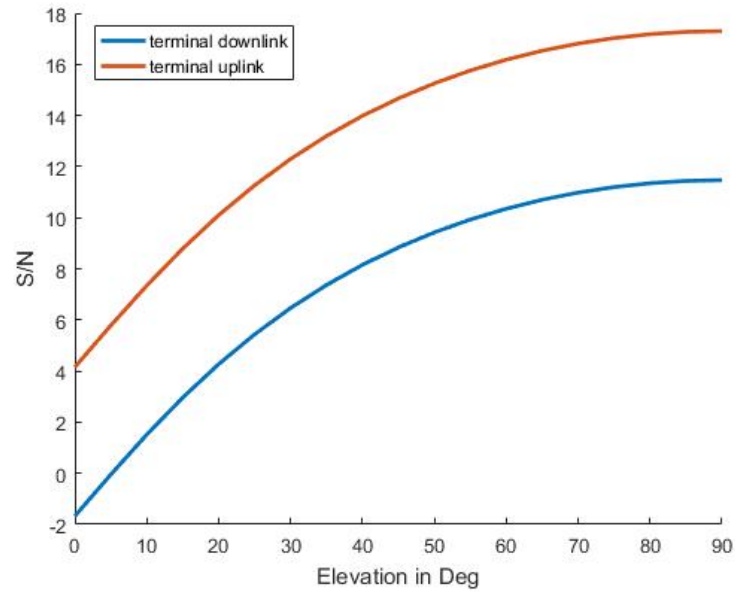

Figure 3.4: Link budget ideal pass

In figure 3.4 the S/N is plotted versus the elevation angle, using the assumptions listed above and using a 0dB terminal antenna. The range to the satellite is calculated using equation 3.4, where R_{sat} is the range between the terminal and the satellite in km, E is the elevation in degrees and h_{sat} is the altitude of the satellite. The difference between the up-link and the down-link originates from the difference in transmit power.

$$R_{sat} = R_{Earth} \cdot \sin(E) + \sqrt{(R_{Earth} \cdot \sin(E))^2 + h_{sat}^2 + 2 \cdot R_{Earth} \cdot h_{sat}} \quad (3.4)$$

In figure 3.4 only the elevation is a variable, there is no variation in the Azimuth, when dealing with real satellite pass this is seldom the case.

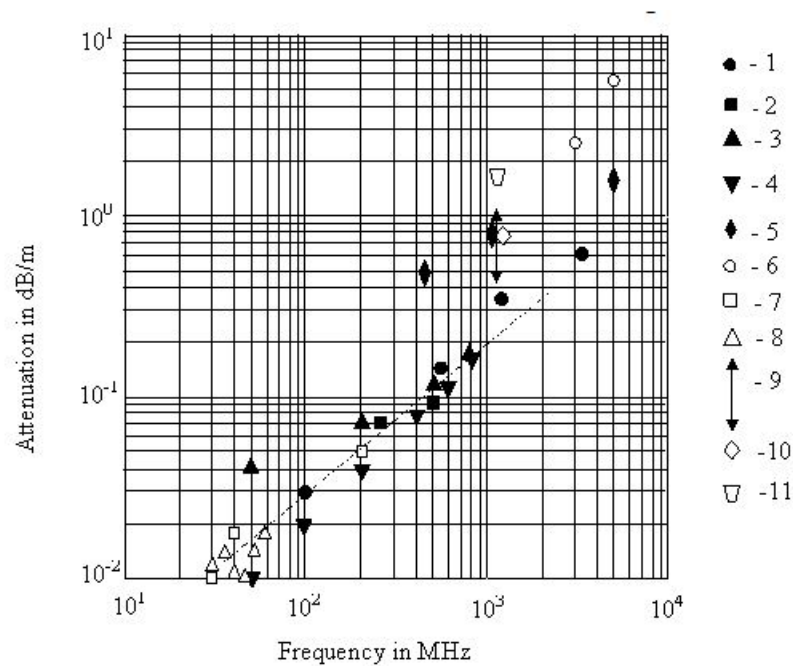

Figure 3.5: Experimental data on attenuation by different canopies [7]

Concerning the remote operation of this ground station, it will be deployed in deserts, plains and forests. The first two will not cause any problem, but transmitting through leaves and branches will need some additional research. In figure 3.5 results of an experiment conducted by [7] are presented, eleven different data sets are used, modelling several tree types. According to [7] the data available is very limited but there is a formula proposed providing a relation between the frequency and the attenuation per meter vegetation ($\alpha = c \cdot f^\beta$). Where f is the frequency, in MHz c is $8e-4$ 1/m and β equals 0.8 . For the up- and downlink frequency in this project it results in an attenuation per meter ranging between 0.07dB/m to 0.08dB/m. Since this is very small it will not be considered in the link budget calculation.

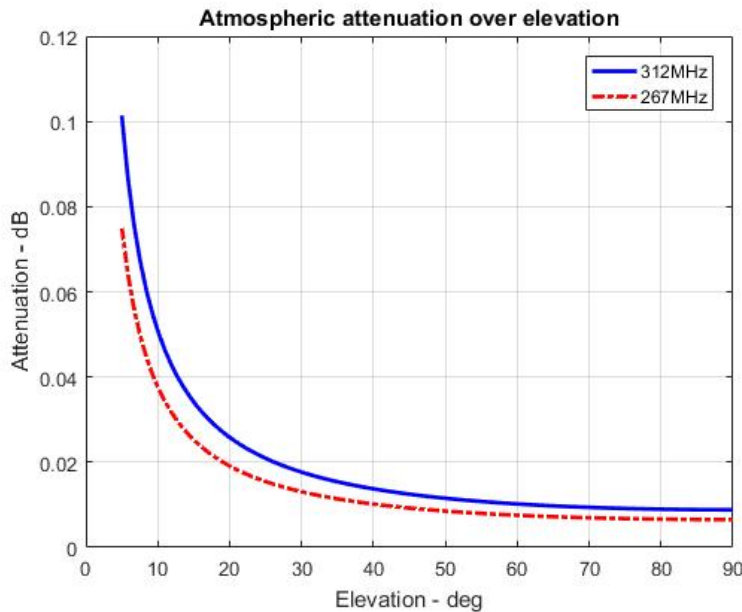
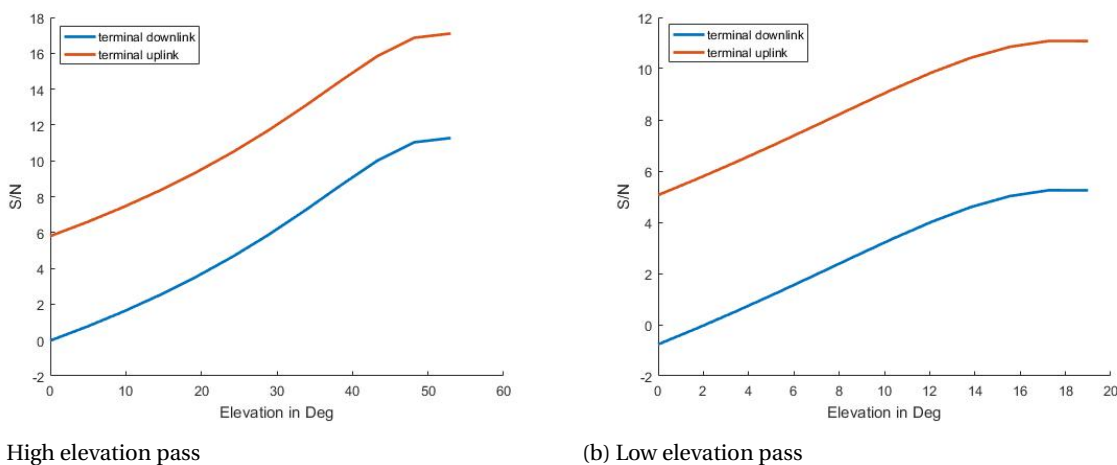

Figure 3.6: Attenuation due to a wet atmosphere (rain)

In figure 3.6 the relation between the attenuation due to atmospheric effects in wet conditions and the elevation angle is presented. This attenuation is related to the elevation angle via the path length. The relation between the path length and the elevation is given by equation 3.4. It can be seen that in wet conditions the attenuation on the up- and downlink frequency is small (0.05dB to 0.04dB at 10 degrees elevation). Therefore, it will not be considered in the link budget calculation.



(a) High elevation pass

(b) Low elevation pass

Figure 3.7: Link budget based on the range of XW-2C for location 52° Long, 4° Lat

To improve the ability to judge the link budget, a calculation was made where the range was not calculated using one simple trigonometric formula but by using the SGP4 model [23]. All other parameters were kept the same. Using the XW-2C satellite which is located in approximately the same orbit as envisioned for the BRIK-II mission. this is a 600km altitude dusk dawn orbit. For passes 3.7a and 3.7b a location in the Netherlands was selected and both have a duration of 11.5 min and 10.5 min respectively. However pass 3.7a has a higher maximum elevation compared to 3.7b. Which makes 3.7a a pass which achieves higher S/N ratio's therefore the channel capacity is much higher.

From these calculations it can be concluded that, the Link budget will not be closed. The overall S/N ratio is too low, especially while downloading from the satellite to the terminal. The S/N could be increased by using a directional antenna, an amplifier and low noise components. Thus ensuring that the design will still comply with requirements BRK-SF-SYS-004 and BRK-SF-SYS-007, but also with BRK-SYS-RRS-001 and BRK-SYS-RRS-002.

3.2. Communications Protocol

One of the most challenging requirement is requirement BRK-SYS-RRS-014 stating that the satellite should be able to accommodate several terminals in the same antenna footprint. There is also a requirement on the satellite payload which says that the terminals should be served without prior knowledge of there whereabouts. The satellite is unable to accommodate two terminals at the same time. This requires a protocol to make a decision on which terminal to facilitate, a baseline is established at a first come first serve protocol. However, this doesn't solve the problem of two terminals contacting the satellite at the same time or successively. In order to solve this problem a terminal starts by listening for a fixed amount of time plus a random amount of time. It is listening for communication between a satellite and an other terminal, this communication is performed using Automated Repeat reQuest (ARQ). ARQ is used for error mitigation but in this design it serves a second purpose, as described above. The random amount of time needs to be added in order to avoid that there are two terminals contacting the satellite at exactly the same time.

The ARQ is based on splitting a message in packages. These packages are sent to the receiver in a certain order. Each package has a check sum, which is a count of bits in a transmission block that is included with the package header or trail in order for the receiver to check whether the same number of bits has arrived. Whenever the check sum is correct the package is answered with an ACK, if the check sum is incorrect the package is answered with a NACK and will be repeated by the sender. The size of the optimal data package is linked to the Bit Error Rate (BER) of the channel and given in equation 3.5 [15]. Where K is the number of bits in a package, p is the BER and h is the number of overhead bits in a package.

$$K_{opt} = \frac{-h \cdot \ln(1-p) - \sqrt{-4 \cdot h \cdot \ln(1-p) + h^2 \ln(1-p)^2}}{2 \cdot \ln(1-p)} \quad (3.5)$$

In figure 3.8 several options for the overhead sizes are given as function of the BER and the package size. On the vertical axis the package size is given in Bit and the horizontal axis presents the Bit Error Rate. As can be seen in the figure for an overhead size of 1500 bits the optimal package size in a 10^{-6} channel BER is 40000 bits.

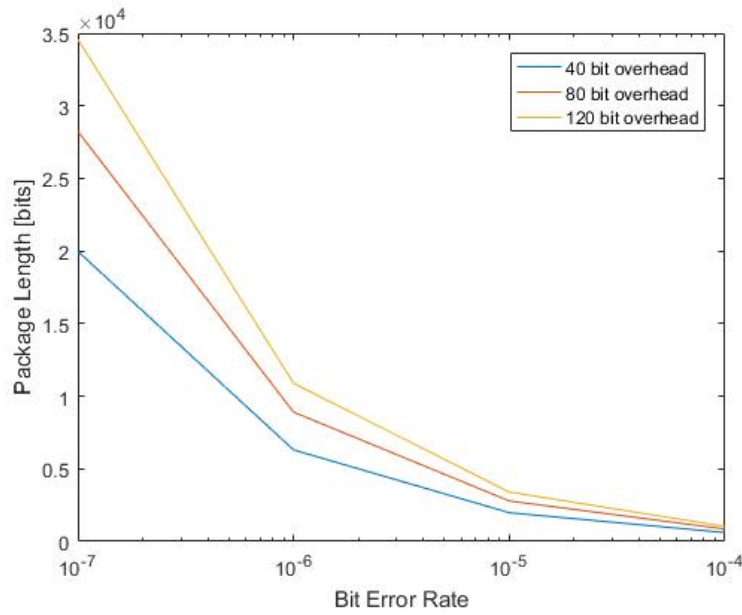

Figure 3.8: BER vs package length in bits for several overhead sizes

In its simplest form the interaction between sender and receiver is visualised in figure 3.9. This interaction is called Stop and wait ARQ. The sender starts sending a package where t_d is the travel time of the signal and t_p the time it takes to send the package. After the package is sent it takes t_d to arrive at the receiver. The receiver checks the package and sends an ACK. It takes the ACK $t_a + t_d$ to reach the transmitter. The cycle can be repeated for the next package if an ACK is received and for the same package if a NACK is received.

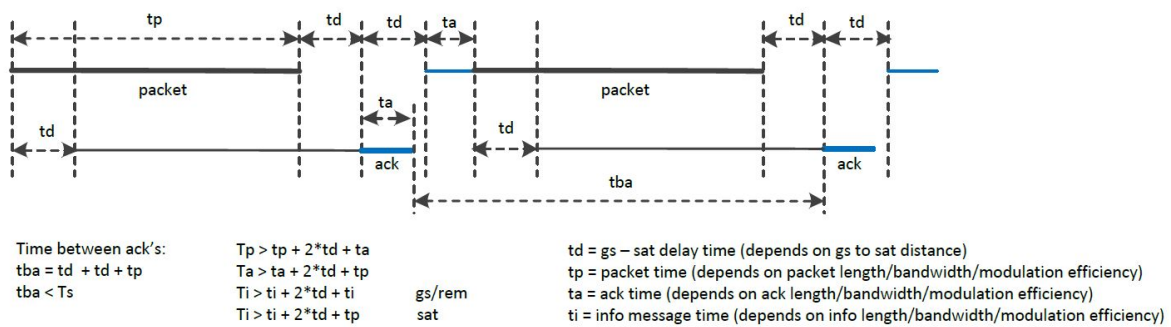
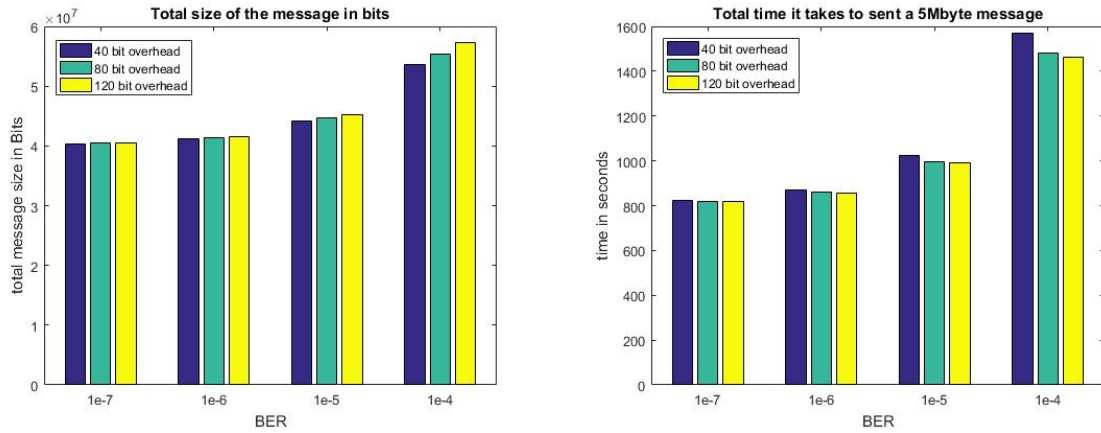

Figure 3.9: Time schedule simple ARQ



(a) Total message size

(b) Total time

Figure 3.10: Left the total volume of a 5Mbyte message including overhead and transmissions, right the total time it takes to transfer this message

In figure 3.10 two bar diagrams are shown in 3.10a the total volume of a 5Mbyte message is displayed for different BER and overhead sizes. This figure also includes the re-transmissions and all the acknowledgements send. In sub-figure 3.10b the time it takes to sent the message size as presented in 3.10a is displayed. These times only take into account the signal travel time (process time is neglected). The assumptions on which graphs 3.10 are based are listed below:

- Bit rate is calculated using QPSK modulation ideal implementation at 2 bit/Hz/s and a bandwidth of 25kHz (Theoretical bandwidth usage)
- No process time was accounted
- The probability of an error occurring is $Err = 1 - (1 - p)^{k+h}$
- The ACK size is fixed to 80 bits
- Signal travel time is calculated using equation 3.4 and the speed of light

It can be seen that using this protocol based on scheme 3.9 a message of 5Mbyte will only fit if the signal to noise ratio is high. When down-linking from the satellite this could be a problem considering low power available and a 0dB antenna. Note that the throughput is connected to the BER but there is a theoretical minimum amount of overhead bits and delay time. This shows that although ARQ is very robust (in terms of error control), it is not ideal for achieving desirable data rates in these sorts of applications.

3.3. Hardware Design

In this section the most important components of the terminal will be addressed. First these components are introduced by means of a Design Option Tree (DOT) as shown in figure 3.11. For each component several requirements and design options will be presented.

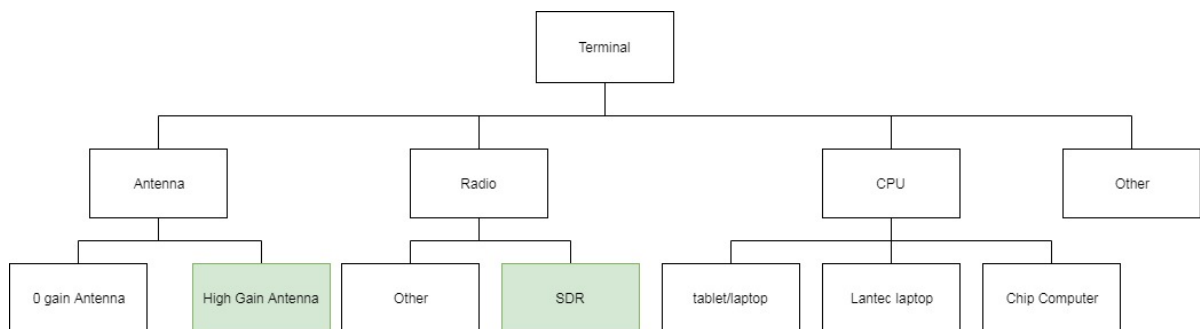

Figure 3.11: Terminal Design Option Three

In figure 3.11 the hardware design is divided in four parts the Antenna, the radio, the CPU and other. Dividing the terminal in several subsystems makes it easier to make choices in the design process. In the DOT some obvious choices are already made by either the general requirements presented in table 2.1 or the knowledge gained earlier in this chapter. A high gain antenna is chosen (or directional antenna) in order to close the link budget but also, to some extent, reduce the the chance of being detected. Concerning the radio an SDR is chosen. Since some work was already done on SDR's and they offer flexibility and are light weight. Concerning the CPU, the choice is made to select a 'credit card' computer, where using the SOF's laptop seems to be the obvious choice, because its part of the standard inventory. In terms of a modular design and flexibility it is more convenient to take an extra 0.2 - 0.5 kg. Everything the SOF teams take with them serves a purpose, it is convenient to use equipment they carry but it should not jeopardise the success of there mission. The hardware components will be discussed in more detail in the following sections.

3.3.1. Antenna

In this subsection an elaboration on the antenna choice is presented. First a selection of specific antenna requirements are derived in table 3.2. These requirements are the starting point for selecting a directional antenna. In order to close the link budget presented later in chapter four the terminal requires an antenna gain of at least 8dBic. Furthermore the antenna needs to be pointed by hand and in order to reduce weight it needs to be as light as possible.

Table 3.2: Antenna Specific requirements

Identifier	ID	Sub System requirement
Antenna Requirements		
BRK-RRS-SUB-ANT	0001	The Antenna shall have a gain of at least 8 dBic
BRK-RRS-SUB-ANT	0002	The half power beam-width of the antenna shall be lower than 30 degrees
BRK-RRS-SUB-ANT	0003	The antenna shall have a mass of no more than 1.5 kg
BRK-RRS-SUB-ANT	0004	The antenna shall have a volume of no more than 2 l
BRK-RRS-SUB-ANT	0005	The antenna shall have a coaxial connector interface
BRK-RRS-SUB-ANT	0006	The antenna shall be able to operate within a temperature range of -32/44 degrees
BRK-RRS-SUB-ANT	0007	The antenna shall withstand a minimum pressure of 56.8 kPa
BRK-RRS-SUB-ANT	0008	The antenna shall comply with test CE106 of MILSTD-461F
BRK-RRS-SUB-ANT	0009	The antenna shall be able to withstand submersion of at least 1 meter
BRK-RRS-SUB-ANT	0010	The antenna shall have a front-to-back ratio no less than 13 dB

Four antenna systems in consideration for this design. The options have all been designed for military use and comply with the MILSTD 810F and MILSTD 461F. As can be observed in table 3.3 there are two antenna's that do not comply with BRK-RRS-SUB-ANT-0001 because their gain is too low. Which leaves the Syntonics antenna and the Harris AT001, where the first is much lighter and smaller than the second. However, the Harris AT001 antenna is already being used by the Dutch SOF teams, although for GEO sat-com. Since this antenna works in the same frequency band it is very well suited for this application. This means that the antenna will not be included in the terminals mass and volume budget, because this antenna is already in the SOF's teams inventory.

Table 3.3: Antenna options

	band(Mhz)	Gain(dBic)	Temp(degree)	VSWR	weight(kg)	volume(l)
Syntonics	243-318	5-8	-31/60	1.5:1	0.49	4.7
TS214	240-318	5	-31/60	1.5:1	0.388	-
Harris SE78	244-318	5	-31/71	1.5:1	0.45	0.365
Harris AT001	240-318	11	-30/70	1.5:1	2.9	10.6

The Harris AT001 comes with a tri-pod which is not immediately relevant to this project, but could be used as a basis for guiding the user to point the antenna. A manually operated gimbal or a mechanical gimbal could be attached between the tri-pod and the antenna. This option will not be discussed further. The front-to-back ratio is not presented in the data sheet. The front-to-back ratio and the half power beam width will be further discussed in chapter 5.

3.3.2. Radio

In this subsection the SDR radio will be selected. In table 3.4 the derived requirements for the radio are shown. Note that although a half duplex system is designed, choosing a full duplex radio (BRK-RRS-SUB-RAD-0006) from this stage in the design process will provide more potential for future usage. For example if a second mission is proposed where the satellite has full duplex capabilities. An other reason is the investigation to see if the radio in the BRIK-II can be transformed to a full duplex radio.

Table 3.4: Radio specific requirements

Identifier	ID	Sub System requirement
Radio Requirements		
BRK-RRS-SUB-RAD	0001	The radio shall have a mass of no more than 0.3 kg
BRK-RRS-SUB-RAD	0002	The radio shall have a volume of no more than 0.2 l
BRK-RRS-SUB-RAD	0003	The radio shall be able to operate between 312MHz-322MHz in transmit mode
BRK-RRS-SUB-RAD	0004	The radio shall be able to operate between 267MHz-273MHz in reception mode
BRK-RRS-SUB-RAD	0005	The radio shall have a minimum RF bandwidth of 25kHz
BRK-RRS-SUB-RAD	0006	The radio shall be a full duplex radio
BRK-RRS-SUB-RAD	0007	The radio shall be able to operate within a temperature range of -32/44 degrees
BRK-RRS-SUB-RAD	0008	The radio shall withstand a minimum pressure of 56.8 kPa
BRK-RRS-SUB-RAD	0009	The radio shall be flexible with respect to the waveform
BRK-RRS-SUB-RAD	0010	The radio shall have a sample rate of at least 75 kbits/s

Table 3.5: SDR solutions

	Sample rate	RF Bandwidth	Tuning range	Power	Volume	temp
Hack RF one	20 MSPS	20 MHz	1 MHz - 6 GHz	-10 dBm	0.09 l	TBC
USRP Ettus B205mini-i	61.44 MSPS	61.44 MHz	70 MHz - 6GHz	10 dBm	0.042 l	-40/75 C
LimeSDR-mini	30.72 MSPS	30.72 MHz	10 MHz - 3.5 GHz	10 dBm	0.021666 l	-40/85 C
Airspy R2	20 MSPS	10 MHz	24 MHz-1.8GHz	- dBm	0.042 l	-10/40 C
BladeRF x115	40 MSPS	10 MHz	300MHz-3.8GHz	6 dBm	0.1107 l	-40/85 C

In table 3.5 a selection of SDR's that are on the market can be found. The selection was based on SDRs that are full duplex and have a sufficient sample Depth and bandwidth. Since there is no immediate best solution in this list as was the case with the antenna choice a more sophisticated trade-off method is used. The analytic hierarchy process (AHP). Note that the mass of the radios was not taken into account as a trade criteria because the masses were very close and not all alternatives had a mass listed in their data description.

This method relies on pairwise comparison of evaluation criteria and alternative options. In this case the trade criteria and the radios listed in table 3.5. The AHP generates a weight for each trade criterion according to this comparison, the higher the weight the more important the corresponding criterion. The next step is to assign a score to each design option according to the pairwise comparisons of the options based on a single criterion. Finally the AHP combines the criteria, weights and option scores resulting in a global score for each option.

The global scores are shown in table 3.6. This shows that the Ettus SDR and the LimeSDR are really close but twice as high compared to the rest. Because the 982SQN has experience with the Ettus board the choice was made to go with the Ettus B205 mini-i including enclosure.

Table 3.6: Score matrix

Product	Score
Hack RF	0.145983
Ettus	0.2977276
LimeSDR	0.2917302
Airspy R2	0.159302
BladeRF	0.1052571

The performance of the trade-off can be measured by its consistency index which was determined to be 0.08. An AHP is deemed consistent if this ratio is below 0.1. In appendix A the full trade-off tables weights and criteria are presented.

$$\frac{Ci}{Ri} = 0.08$$

About USRP a SDR family that hosts the Ettus B200 mini:

- Connected by USB 2.0/3.0
- External frequency reference possible
- External PPS timing reference possible

Using matlab Simulink [14] or GNU radio companion [20], GRC offers flexible integration via the UHD USRP® block, Matlab uses the same kind of interface but the UHD can only host two types of ettus boards namely the USRP2 and the USRP N@x0. Since the B205 mini was chosen the radio software will be developed in GNU radio.

The Ettus B205-mini-i has a protective cover which should be included because it operates as a heat sink, it is not meant as protection against the elements. The SDR's mass is determined using a simple kitchen scale which resulted in a total mass (incl. cover) of 108g.

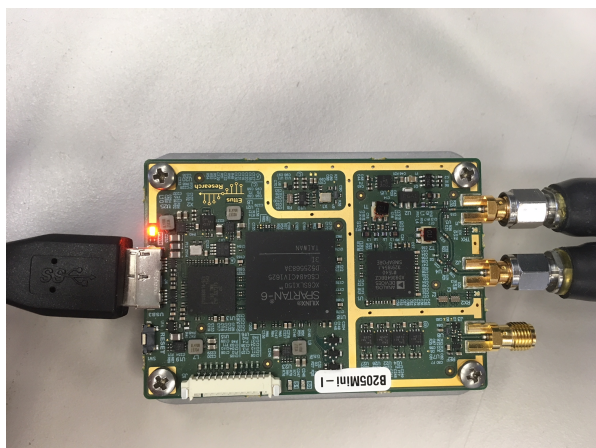

Figure 3.12: Picture of the Ettus B205 mini-i without enclosure

3.3.3. CPU

In this section the nerve centre or CPU of the terminal shall be chosen. First a set of specific requirements will be presented, thereafter a selection on CPU's available on the market. In contrast to the selection of the radio, no AHP process will be used when choosing a CPU. Using AHP is time consuming and for this particular subsystem it is expected that there are a large number of options that will comply with the requirements.

In table 3.7 the specific CPU subsystem requirements are stated. These are derived from the terminal requirements. The mass and volume will be discussed in section 3.4.2. The number of connectors is based on the foreseen interfaces, for instance the Ettus B205 uses standard USB-3 but other devices could be using SPI, UART or something equivalent. The requirements concerning operational temperature and pressure are derived from table 2.3.

Table 3.7: CPU Specific Requirements

Identifier	ID	Sub System requirement
CPU Requirements		
BRK-RRS-SUB-CU	0001	The control unit shall have a mass of no more than 0.5 kg
BRK-RRS-SUB-CU	0002	The control unit shall have a volume of no more than 0.2 l
BRK-RRS-SUB-CU	0003	The control unit shall consume no more than 80W
BRK-RRS-SUB-CU	0004	The control unit shall have at least 2 USB (or equivalent) interface connectors
BRK-RRS-SUB-CU	0005	The control unit shall have at least 1 power interface connector
BRK-RRS-SUB-CU	0006	The control unit shall have at least 1 display interface connector
BRK-RRS-SUB-CU	0007	The control unit shall be able to operate within a temperature range of -32/44 degrees
BRK-RRS-SUB-CU	0008	The control unit shall withstand a minimum pressure of 56.8 kPa

In table 3.8 three CPU options are listed. These options have been selected because they have similar process power and can host a Linux operation system. Each device can be purchased in different configurations but for comparison proposes the power, volume, temperature, interfaces and CPU TDP are listed. These features are similar for each configuration. Non of the options comply to the operating temperature requirement. Therefore, temperature control should be included.

Table 3.8: Design options CPU

Device	CPU	Power	Volume [cmxcmxcm]	Operational temperature [°C]	Interfaces	TDP [W]
NUC 7i7 DN	intel i7 8650U	65W @ 19V	11.5x11.1x3.5	0 / +40	GbE, SATA3, 2x HDMI and 4x USB3	15
STK2mv64CC	Intel Core m5-6Y57	15-20W @ 5V	11.4x3.8x1.2	0 / +35	HDMI 1.4b 1x USB3 + 2 hub	-
Adlink com express type 6	Intel i7-6820EQ	ATX 12V	12.5x9.5x3.5	0 / +60	GbE, 4x SATA, 4x USB 3.0, 4x USB 2.0 2x UART and 8x GPIO	45

Based on the information provided in table 3.8, the STK2 lacks sufficient interface options. This keeps the choice between the NUC and the Adlink, in the data sheet the Adlink has an option which will expand its operating power to -40/+85 C°. However, this is a build on option which is only applicable for a specific core system. Furthermore the Adlink should be seen as a development board, which offers flexibility and therefore also a higher work load. Since there should be some thermal control design, the TDP should be taken into account as a number to compare. The TDP indicates the power dissipated through heat by the main processor chip. Since the NUC out performs the Adlink by a factor three in this field the NUC is chosen to be the

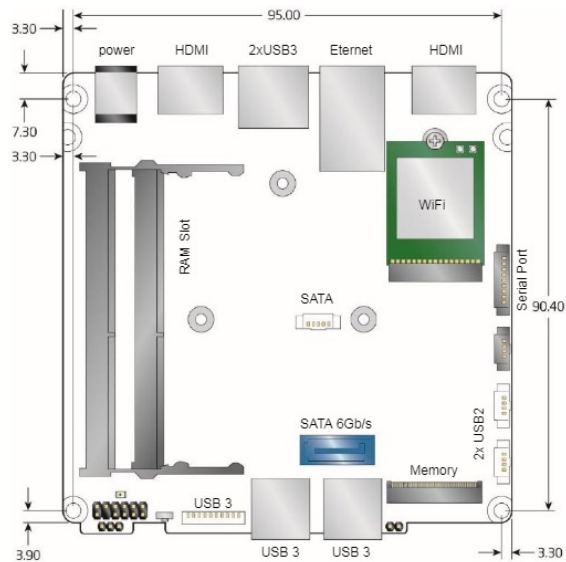

Figure 3.13: Layout of the CPU board (NUC 7i7 DN)

desired design option. Note: this board comes without storage and RAM. A detailed layout of the board can be observed in figure 3.13 where all relevant ports and slots are indicated. The NUC including memory and ram was put on a kitchen scale and the mass was determined to be 520 gr.

3.3.4. Amplifier Design

Power amplifiers are used to increase the gain of a signal just before it is radiated by the antenna. To design a power amplifier the frequency, output power and modulation need to be. The output RF power is estimated to be 5 Watt, frequencies are known and the modulation family is set to be PSK modulation (BPSK, QPSK and 8-PSK). Due to the oscillation of the base-band signal when changing symbols the amplifier could saturate. The amplitude variations are large for transitions passing through zero. A base-band QPSK signal is presented in figure 3.14a. This is the actual I and Q signal as produced by GNU radio PSK modulation block. The signal oscillation can clearly be observed in both signals, the amplitude is given by equation 3.6.

$$V_{amp} = \sqrt{I^2 + Q^2} \quad (3.6)$$

It can be observed that negative and positive peaks in respectively I and Q result in an even larger (positive) peak. Where I represents the in-phase signal and Q the quadrature-phase signal. Because of these high peaks, this wave form will have a high peak-to-average power ratio. A power amplifier is set to raise the average power of a signal. So these peaks can run into the saturation limit of the PA. This causes inter modulation distortion which generates spectral regrowth. 8-PSK was chosen to estimate the amplifiers head room, because the peak to average power oscillation is larger with respect to BPSK and QPSK.

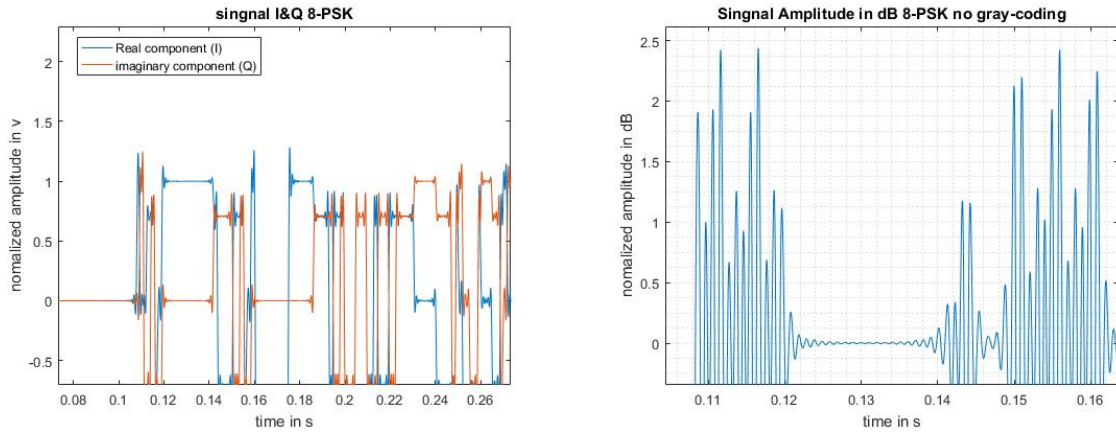

(a) Signal Amplitude in Volt (normalised to 1)

(b) Same signal amplitude in dB

Figure 3.14: Left the signal amplitude after 8psk modulation in volt, right the same signal amplitude in dB

In figure 3.14b the amplitude of the base-band signal of figure 3.14a is presented and converted to dB. It can be observed that the highest peak to average power recorded is 2.4 dB. A head room of 3dB will be accounted for while sizing the PA. Furthermore the conversion of electric power to RF power needs to be taken into account, set at 40%. A rough power budget is presented in table 3.9. The required RF power would be 5W accounting a 3dB headroom to prevent saturation or a factor 2 results in 10 watt with a conversion efficiency of 0.4 gives the 25W of total input power.

Table 3.9: Estimated DC power required to generate 5W RF signal

PA sizing	Value
RF Power	5W
Head room	3dB
conversion eff	0.4
total power	25W

This would give an indication on which suitable candidates can be used for the design. A selection of possible candidates are listed in table 3.10. It can be observed that although the NuPower has an operating range between 225-2400 MHz its efficiency is high (at the specific frequency required). Note only the uplink frequency (312-322MHz) is considered since this subsystem only operates in the Tx path. Due to the small form factor and low required input power the NuPower NW-PA-11C01A will be base-lined for this design. The efficiency of the other two options were not listed in the data sheet.

Table 3.10: Design options Amplifier

Amplifier	Frequency [MHz]	RF Power [Watt CW]	Efficiency	Req. input power [dBm]	Temp [C°]	Mass [g]	Volume [cmxcmxcm]
Exodus Advanced com. AMP3014	290 - 320	30	-	8	-20 / +75	400	14x8x2.4
Yonlit PWR-GNR-180	280 - 330	25	-	3-8	-20 / +60	<2000	21x11x2.5
NuPower NW-PA-11C01A	225-2400	15	42 % @ 310 MHz	0	-40 / +60	85	7.6x5x 1.6

3.3.5. Additional Components

Apart from the three main components, the terminal needs to have a power source, a human machine interface, a automated position acquisition and direction sensor. Furthermore it should be portable and resistant

to various environments. All additional components are listed in 3.11

Table 3.11: Auxiliary components

component	power	interface	volume [cmxcmxcm]	ops temp [°C]	weight [g]
Neo Blox M8n	23mA@ 3V	Spi, UART, I2C	3x3x1	-40 / 85	9
display ardafruit 5" 800x480	250mA or 500mA @ 5V or 3 V	HDMI, USB	12x7.5x1	-20 / 70	106

Apart from the components listed in table 3.11 a power distribution board needs to be added. Because the amplifier will need a certain power line which is probably different from the power needed by the CPU. All the other devices are powered via the CPU either through USB, UART or HDMI connections.

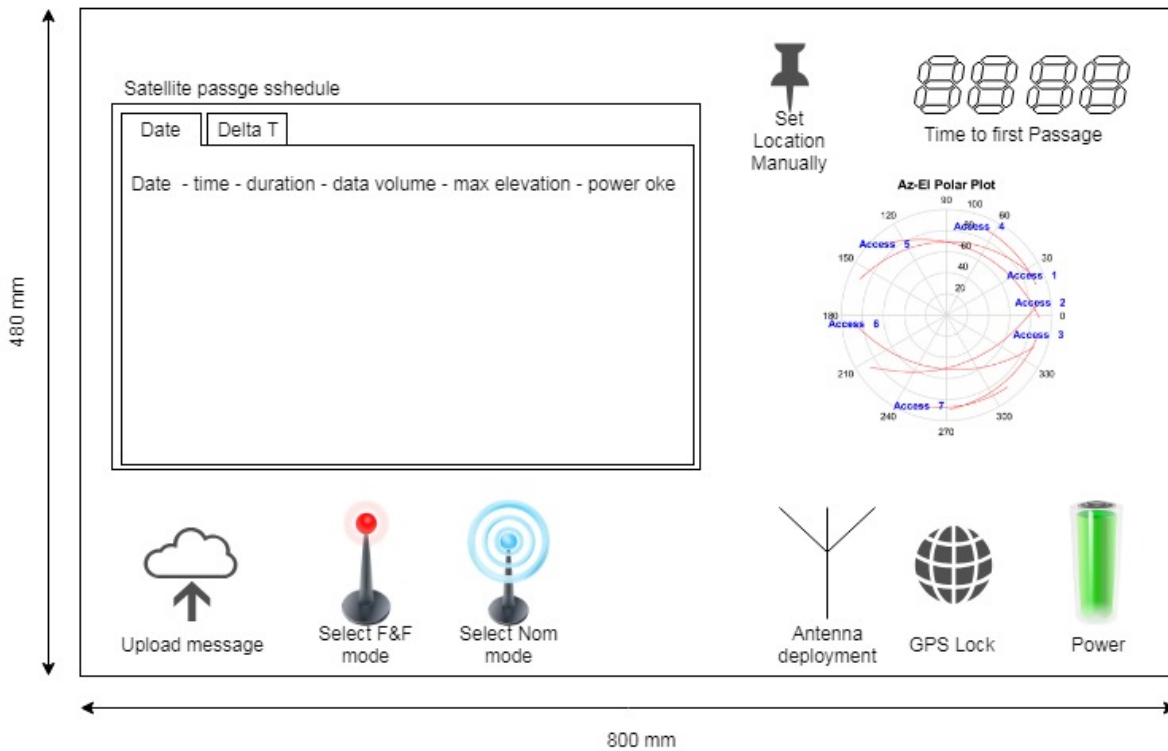

Figure 3.15: HMI Dashboard impression

A possible dashboard layout can be observed in figure 3.15, where a couple of important features are displayed. At the right the user will be able to select a satellite passage. Either by selecting from the date tab, choosing a passage by date and time or via the delta T tab choosing a passage within a certain amount of hours minutes. The digital clock at the top left will, after choosing a particular passage, display the time until the satellite appears at the horizon in hours and minutes. If the passage occurs within the hour it will switch from minutes to seconds. At the bottom of the display an number of information icons/buttons can be found, from left to right, a button to upload a message, two selection buttons for F&F or nominal mode. Furthermore the antenna deployment/attachment, GPS lock and battery level is indicated. An optional polar plot of the passages is displayed in the mid left. Using the thumbtack icon the user can manually overwrite his location, which is convenient when using the terminal, for mission planning or when there is no lock on the commercial GNSS sensor. Note the Satellite will communicate to the terminal what the required operation will be,

either there is a message in the satellite that is supposed to be delivered to the terminal, or the terminal is allowed to upload a message. This will be communicated to the user via a pop-up screen.

3.4. Hardware Component Interaction

3.4.1. N2 Chart

In order to give an overview of the interfaces between the components an N2 chart is constructed. The chart can be found in table 3.12. In an N2 chart all system components are on the main diagonal, the row and column of a specific cell on the main diagonal describe the interface. The chart should be read clockwise.

Table 3.12: System N2 Chart describing the interfaces

Antenna					Incoming signal (analog) via COAX 50 ohm
	Human machine interface	Information to be sent via USB			
	information to display, via USB (max 500mA @5V)	Control unit			Information packages, and power via USB (max 500mA @ 5V)
		Power: 45W @ 12V	EPS	Power: 32V @ 2.4A	
Amplified signal COAX 50 ohm				Amplifier	
		Digital demodulated signal		Analog signal for transmission COAX 50 ohm	Radio

3.4.2. Budgets

The power budget helps sizing an EPS which shall have impact on the volume and mass budget, therefore the power budget is determined first. In the data sheet of the NUC7i7¹ page 61 a breakdown can be found on the estimated power consumption per adaptor. All relevant components are summarised in table 3.13. Note that the HMI and the radio along with other external components (like gps sensor) are powered through the NUC7i7 via USB. Five USB3 ports are taken into account, four required to deliver 2.5 watts and one (for the SDR) required to deliver 5 watts. The DDR4 SODIMM is the RAM adaptor and M.2 Module is the system memory adaptor. An extra 10 percent margin is taken into account for unforeseen items.

Table 3.13: Power Budget

Subsystem		Power [W]
NUC 7i7 ¹		
	CPU KLB-U	15
	Chipset	2.38
	DDR4 SODIMM	4
	M.2 module	3.03
	5xUSB3	15
	HDMI 2.0	0.06
Amplifier		76.8
margin (10%)		11.6
Total:		127.81

¹https://www.mouser.jp/datasheet/2/612/NUC7i7DN_TechProdSpec-1316759.pdf

There are batteries that have a MIL-STD qualification, these batteries are already used by the SOF teams and have an internal power management system. Qualified for military operations and functional in the right temperature ranges. the key parameters are listed in table 3.14. As can be observed the capacity is sufficient to comply with requirement BRK-SYS-RRS-023. This requirement states: operations for 100 minutes should be possible ($127.81W \cdot 1.66h = 213Wh$) . Concerning the voltage required by several subsystems some power regulation device will be needed including some DC-to-DC converters.

Table 3.14: Battery specifications

Product	Capacity [Wh]	Discharge [A]	Nominal voltage [V]	ops Temp [C°]	Weight [kg]	Volume [cmxcmxcm]
BT-70791CG	237.6	10	28.8 (2x14.4)	-20 / +60	1.4	11.2x6.1x12.7

Secondly the volume budget will be calculated, not accounting for the antenna since this subsystem is already part of the standard equipment carried by SOF teams. After the volume is determined an initial housing format can be chosen in order to calculate the mass budget.

Table 3.15: Volume Budget

Subsystem	volume [l]
Radio	0.042
CPU	0.463
Amplifier	0.231
HMI	0.090
GNSS receiver	0.009
Battery	0.868
margin (40%)	0.681
Total:	2.384

Table 3.15 lists the volumes of all relevant subsystems, note that there is a margin of 40% to account room for cabling, special connectors, room for cooling and unforeseen additional components. This results in a total volume of 2.384 l. Excluding a protective casing which will be necessary to comply to all the environment requirements. In figure 3.16 a plot is presented which gives the relation between mass and internal volume of protective covers [22] that comply to the MIL-STD requirements presented in table 2.3. As indicated by the cursor the size of the cover needed for this design will have a presumable mass of 0.8 kg. Due to these factors the external volume will end up in the range between 12 l to 16 l.

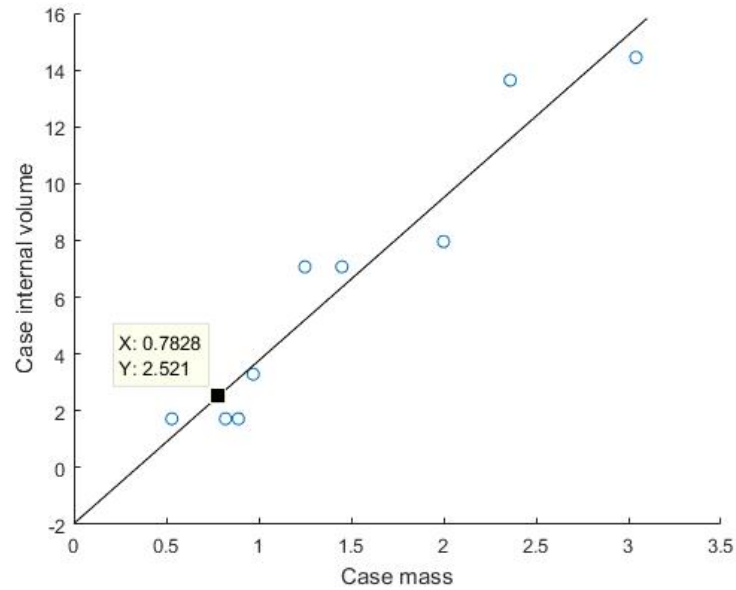

Figure 3.16: Market survey of internal case Volume vs Mass [22]

Thirdly the Mass budget is determined, it is presented in table 3.16. A margin of 20% is allocated for cabling, extra connectors, and unforeseen components.

Table 3.16: Mass Budget

Subsystem	mass [kg]
Radio	0.108
CPU	0.520
Amplifier	0.085
HMI	0.106
GNSS receiver	0.009
Battery	1.400
Protective cover	0.783
margin (20%)	0.602
Total:	3.613

3.5. Software Design

In this section the GRC flow graph will be discussed and its integration with the service software. In the section hereafter a small discussion on the SGP4 model will be presented.

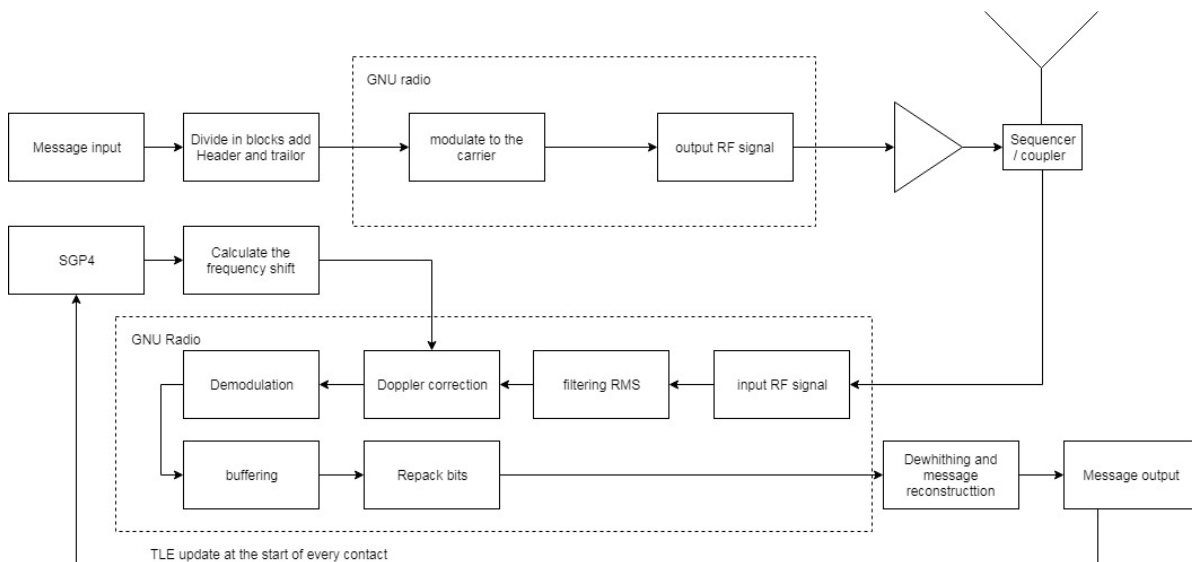

Figure 3.17: Overview of the Software

As indicated in figure 3.17 a large part of the actual signal processing will be done in GNU Radio, this will be supported by C++ code which will handle most of the message handling, making message blocks, adding headers and footers and do the error control. The display software, and at some point rotor control or guiding software will not be discussed.

3.5.1. Channel Synchronisation

When transmitting a signal it is in general modified by the channel before reception, due to additive noise, frequency offset, time delay, phase offsets, multi-path propagation and other distortions. Channel synchronisation can be performed in two ways: feed forward (or open loop) or feedback (closed loop). [8]

Feed forward:

- Block oriented
- Operate on samples for a number of symbols at a time
- Non-tracking, but can be computationally complex
- Burst mode communications, or initial acquisition of synchronisation

Feedback:

- Stream oriented
- Operate on immediate incoming sample or symbol
- Tracking, and not computationally complex for any one input
- Continues stream of symbols, tracking after initial acquisition

GNU radio offers several implementations of channel synchronisation, although it is originally designed as a stream oriented programming tool, there are options where the user can work with blocks. In chapter 5 an investigation on the possibility to do this using GNU radio will be discussed. In the next section an initial software design is presented.

3.5.2. GNU Radio Design

Using a SDR techniques requires software development, the software will do the heavy lifting therefore a preliminary software design will be presented in this section. In chapter five the design will be put to the test using a channel model. GRC is able to interface with the radio board, providing a simulation environment which is close to reality.

While performing the actual signal processing there are two paths to consider: the transmitting path 3.18, and the receiving path 3.19.

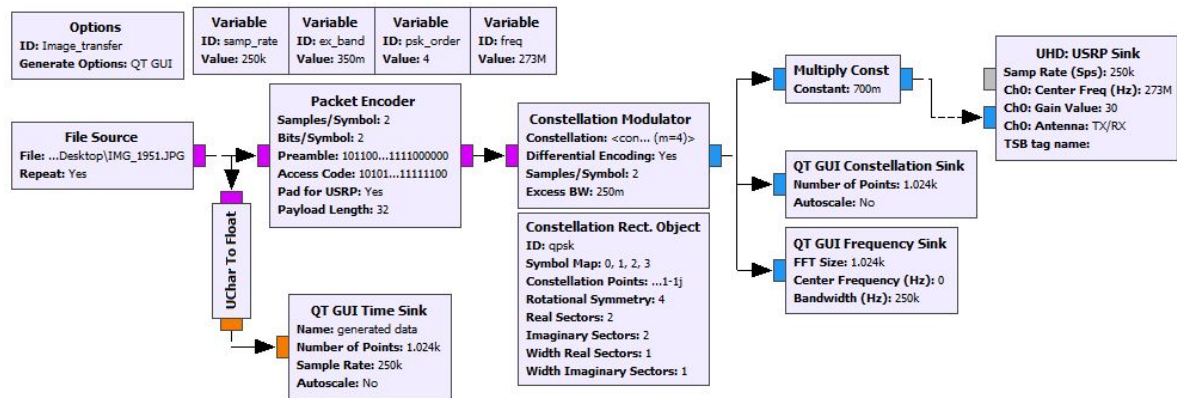

Figure 3.18: The Tx flow-graph

The transmit (Tx) path is the simplest of the two, starting at the left a file is loaded as a byte stream, this byte stream is passed to a Packet encoder block. This block takes a fixed number of symbols and adds a preamble, header and a so called packet length number. It takes as an input unsigned char inputs (0 to 255 8 bit integers). These things will make it is easier to recover the data on the receiving side. This block then passes the stream on to a modulation block which converts the bit stream to complex numbers (basically I and Q). The stream now consists of alternately real and imaginary numbers. The data stream is passed to the UHD block which is the interface to the Ettus board.

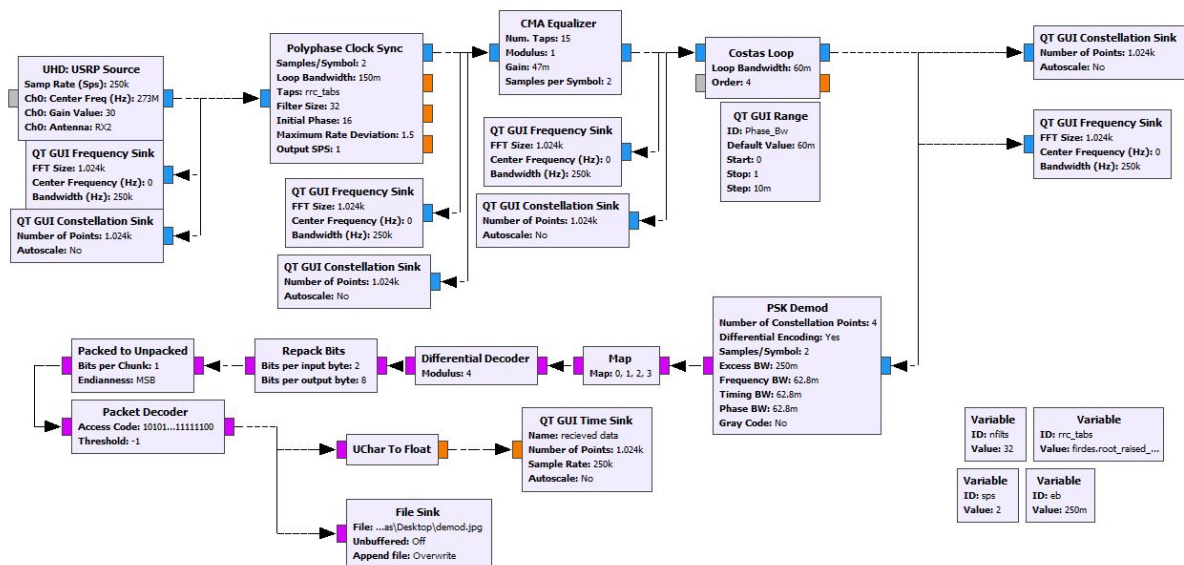

Figure 3.19: The Rx flow-graph

The receive (Rx) path is much more complicated, because the incoming signal is subjected to all sorts of distortion, and these need to be compensated. Like the transmission path an UHD block is incorporated, getting the signal from the Ettus board. This signal is first put through a Polyphase clock synchronise. This block includes two filters where the first filter is a pulse shaping matched filter (like a root raised cosine) and

the second filter is the first filter's derivative. When considered in the time domain, the first filter has a sinc shape. The signal needs to be aligned to the peak of this sinc. The derivative of the sinc shape is zero at the sinc maximum, this is used to determine the error [21] or time offset. Once the signal has passed this block it continues as a complex stream to the CMA equaliser. This block minimises the mean square error without using a training period as conventional equalisers do. The details can be found in [9]. Now the signal is almost ready to be demodulated, only a frequency and phase rectification needs to be performed. This is done by the Costas loop, which works equivalently to a second order Phase lock loop. Now the signal can be demodulated. This is done by a demodulation block, which takes a complex input stream and outputs data as 1 bit per byte LSB.

3.5.3. SGP4 Model

The Simplified perturbations model is used to calculate the orbital state vectors of satellites and space debris relative to the Earth Centred inertial coordinates. The model accounts for the following perturbations:

- Shape of the Earth (oblateness)
- Drag (due to the Earth's atmosphere)
- Radiation (Earth Albedo and sun radiation)
- Third body effects (sun and moon gravitation)

This model is generally used for near earth objects with an orbital period less than 225min. The exact code used in this project can be found in [24]. The error growth over time is one of the main issues. The Terminal needs to operate remotely, so it will depend on TLE information of several days old to determine the satellites location. In order to obtain insight in the error propagation in time a test was conducted.

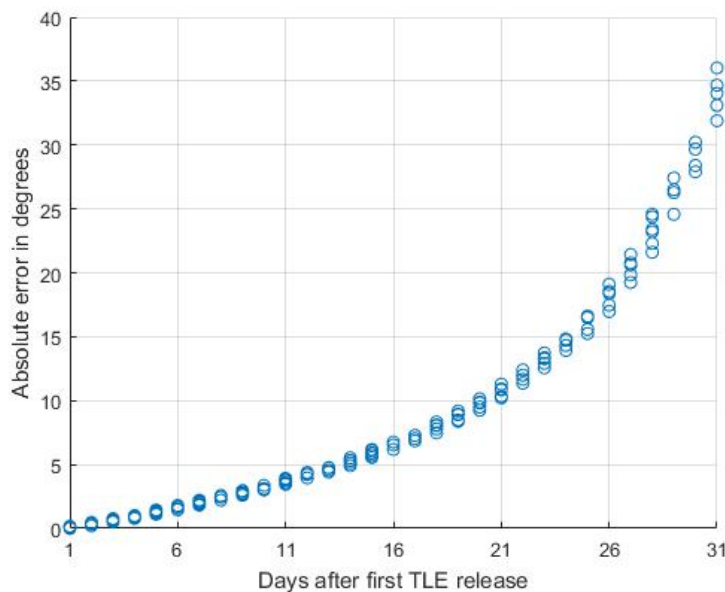

Figure 3.20: Accuracy of the SGP4 model using TLE information of the XW-2C satellite

Figure 3.20 is generated using the SGP4 model as proposed in [24]. In order to check the error growth in time a set of 145 TLE's is downloaded from: www.space-track.org. The satellites location is computed using the latest released TLE, this is treated as the reference point (error =0 and time = 0). All the other TLE's are used to compute at the same time the satellites position. The positions are translated to an elevation and azimuth of an observer on the surface of the Earth. In plot 3.20 the error is the square sum of the elevation and azimuth. On the X-axis the days from the latest released TLE are provided. Note, this plot is generated during a Solar minimum, during a solar maximum it is expected that the miss-alignment error will grow faster in time.

Investigating the SGP4 model is important in order to guarantee remote operations of the terminal. Once the SOF team is deployed they most likely don't have access to internet, therefore they need to rely on old TLE information. After a certain amount of time the TLE will be too old and the user will not be able to contact the satellite. This challenge can be circumvented by occasional contact with the satellite, which carries a GNSS sensor and thus can generate its own TLE. The User should be informed about this and the terminal should be able to indicate if making contact is still possible.

4

Requirements Verification

In the previous chapter the hardware design of the terminal was done. In this chapter the mission requirements verification will be done. There are a number of issues addressed in the previous chapter that were not solved by any hardware implementation; for example requirements BRK-SYS-RRS-014 and BRK-SF-SYS-001. There are however some challenging contradictory parameters that need to be covered. First it will be explained how multiple ground stations will be accommodated. Second the data rate will be calculated, starting with a trade-off in modulation technique and filter roll-off. It will be concluded with a more refined total data volume in comparison to the previous chapter. This chapter will be concluded with a requirements checklist.

4.1. Multiple terminals in one footprint

In this section requirement BRK-SYS-RRS-042 will be elaborated on. This requirement originates from the assumption that the satellite has a large footprint. Since most conflicts now a days take place around the Middle East it is evident that multiple terminals could operate close to one another. The terminals are unable to communicate to each other without the satellite. This is a challenge that is solved following a number of steps, and can be best explained using two different scenarios in the first scenario there is only one terminal:

1. Terminal listens for a random amount of time
2. Terminal initiates contact
3. Satellite communicates if terminal is allowed to send or receive
4. Message transfer takes place
5. Both satellite and terminal disable link

In scenario two there is a second terminal in the satellites footprint wishing to make contact. Now the satellite will handle both at a first- come-first-serve basis. Discrepancies between the terminals is indicated by terminal 1 and terminal 2.

1. Terminal 1 listens for a random amount of time
2. Terminal 1 initiates contact
3. Satellite communicates if terminal 1 is allowed to send or receive
4. Terminal 2 listens for a random amount of time
5. Terminal 2 detects message/ACK traffic and remains silent
6. Terminal 1 concludes message transfer and disables link
7. Terminal 2 detects no traffic and initiates contact
8. Satellite communicates if terminal 2 is allowed to send or receive
9. Terminal 2 concludes message transfer and disables link

In scenario 2 it is assumed that there is enough time to accommodate both terminals, in reality an assessment should be made by terminal 2 concerning the possibility to transfer within the time window of the satellite pass. One of the solutions would be to add information to the ACK or header knowledge about the total message size (in the transfer between satellite and terminal 1). This information can be received and interpreted by terminal 2 and makes the assessment of a possible message transfer in this particular pass easier.

4.2. Data rate

As has been stated in 2.2 the data needs to fit in a 25kHz band. Furthermore the assumption that the satellite uses a zero dB antenna, results in the achievable link budget to be limited. Therefore the most effective way of writing the data in the frequency band should be used. This is the modulation scheme. In the first subsection this modulation scheme will be chosen, next the implementation will be explained. As can be seen in figure 3.4 the SNR changes significantly during one pass. This means that at higher elevations a higher data rate could be achieved. This will be further investigated in the last subsection of the data rate section.

4.2.1. Modulation scheme

In order to code information in a radio wave modulation is used. There are three main types of modulation, namely frequency, phase and amplitude modulation. In this section a trade-off will be presented to investigate which type of modulation will be used.

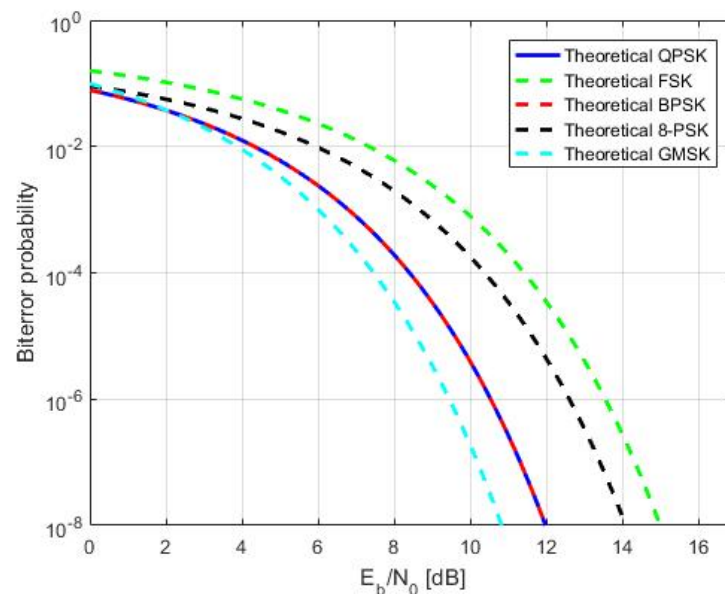

Figure 4.1: Different Modulation techniques

In figure 4.1 a quantitative comparison between FSK and PSK modulation is presented. This figure is produced using the formulas in table 4.1. Where GMSK is a different form of continuous phase FSK [8]. It can be seen that traditional FSK requires a much higher SNR at the same channel quality (BER) compared to BPSK or QPSK. QPSK and BPSK have similar BER curves, this is because QPSK can be regarded as a pair of orthogonal BPSK signals, the real component is one BPSK system and the imaginary component is the other.

BPSK	$P_b = \frac{1}{2} \operatorname{erfc} \left(\sqrt{\frac{E_b}{N_0}} \right)$
QPSK	$P_b = \frac{1}{2} \operatorname{erfc} \left(\sqrt{\frac{E_b}{N_0}} \right) - \frac{1}{4} \operatorname{erfc} \left(\sqrt{2 \frac{E_b}{N_0}} \right)^2$
8-PSK	$P_b = \frac{1}{3} \operatorname{erfc} \left(\frac{E_b}{N_0} 3 \right) \cdot \sin \left(\frac{\pi}{8} \right)$
FSK	$P_b = \frac{1}{2} \operatorname{erfc} \left(\sqrt{\frac{E_b}{N_0} \frac{1}{2}} \right)$
16-PSK	$P_b = \frac{1}{4} \cdot \operatorname{erfc} \sqrt{4 \cdot \frac{E_b}{N_0}} \sin \left(\frac{\pi}{16} \right)$

Table 4.1: Bit noise per modulation scheme

In table 4.2 the advantages and disadvantages of ASK, FSK and PSK are listed. As can be observed, the ASK is susceptible to noise and FSK is not efficient with respect to spectrum usage. This leaves PSK as the most suitable option. In the next subsection an investigation towards the spectral efficiency of PSK will be conducted.

Table 4.2: Coarse trade-off between ASK, PSK and FSK

Advantages	Disadvantages
Amplitude modulation	
Simplicity	ASK is very susceptible to noise interference
Frequency shift keying	
FSK is less susceptible to errors in comparison to ASK, voltage(noise) spikes can be ignored	FSK spectrum is 2X ASK spectrum not so efficient
Phase shift keying	
Can transmit the same amount of information with half the bandwidth (BFSK vs BPSK)	Power in FSK is better than compared to PSK

4.2.2. Spectral Efficiency

The roll-off factor determines how 'strong' the PSK modulation is imposed on the frequency band. It determines the spectral efficiency of a modulation technique. The roll-off normally takes a value between 0 and 1, the closer the number is to 0 the closer the efficiency is to its ideal value. Sometimes the roll-off factor is referred to as alpha, or occupied bandwidth of a root raised cosine filter. [8]

$$r = \frac{f_{\Delta}}{f_0} \quad (4.1)$$

Equation 4.1 represents a more mathematical expression for the roll-off. The definition of f_{Δ} and f_0 can be seen in figure 4.2, note B is half the bandwidth and f_1 is half the occupied bandwidth.



Figure 4.2: Schematic band-pass signal of a root raised cosine filter [8]

Figure 4.3 shows the amplitude response of different values of the occupied bandwidth for the root raised cosine filter incorporated in the PSK modulation block.

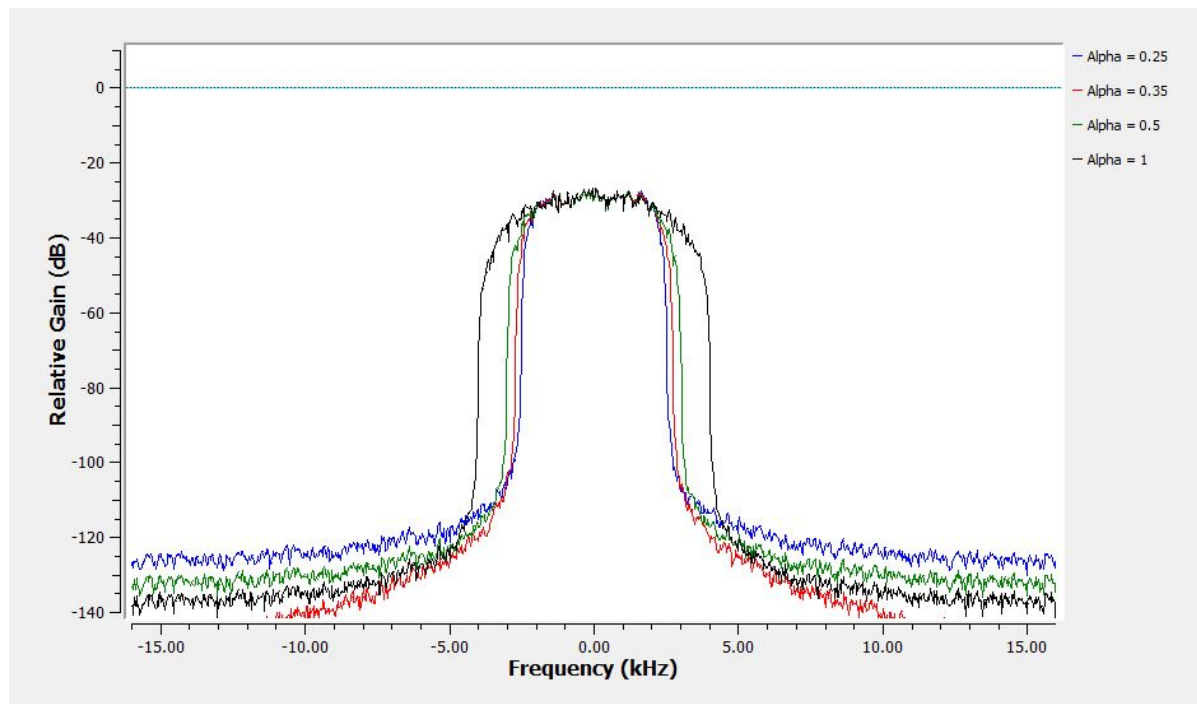

Figure 4.3: Roll-off effect simulated in GNU Radio

Figure 4.3 is generated when running the GRC flow-graph as presented in B figure B.2. This relatively simple simulations help determining the real spectral efficiency of the modulations in scope of this project for different roll-off factors. Using formula 4.2 the sample rate (SR) times the bits per sample (BPS) give us the bit rate. This should then be divided by the samples per symbol modulated in the spectrum times the actual used bandwidth (OBW). The actual bandwidth used by the modulation block can be measured from the frequency plot, the samples per symbol is an input value.

$$Spec_{eff} = \frac{SR \cdot BPS}{SPS \cdot OBW} \quad (4.2)$$

The spectral efficiency's of BPSK, QPSK and 8-PSK are presented in table 4.3, for roll-off factors of 0.5 and 0.25. From these values it seems that the smaller the roll-off the more information can be packed in the signal. This is true, however it comes at a price. The smaller the roll-off, the higher the implementation loss or BER sensitivity. This can be observed by the higher noise level for lower roll-off factors in figure 4.3.

Table 4.3: Different Roll-Off factors for BPSK, QPSK and 8PSK

Modulation	Spectral efficiency (bit/Hz/s)	Spectral efficiency roll-off 0.5 (bit/Hz/s)	Spectral efficiency roll-off 0.25 (bit/Hz/s)
BPSK	1	0.69	0.82
QPSK	2	1.42	1.64
8PSK	3	1.88	2.27

4.2.3. Time loss due to message handling

As stated before the choice for ARQ is very convenient in terms of robustness and in accommodating multiple terminals. But a significant disadvantage is timing, as can be seen in figure 3.9. The waiting time can be broken down in several components, however only the two most significant will be discussed. Namely the signal travel time and the time it takes the radio to perform the ADC and DAC. The first can be determined as follows: the signal travels at light speed and the distance can be computed as function of the elevation using equation 3.4. The result is summarised in table 4.4.

Table 4.4: Signal travel time as function of the Elevation

Elevation[degree]	10	20	30	40	50	60	70	80	90
Time [ms]	6.818	4.964	3.855	3.174	2.742	2.464	2.292	2.197	2.167

To determine the time the Ettus B205 needs to perform the ADC and the DAC processing is more complex. Using the classical GNU Radio blocks this proved to be unsuccessful, therefore two OOT modules were produced. The complete flow graph can be seen in 4.4 where the 'Meas time source' and 'Meas time sink' are the OOT modules.

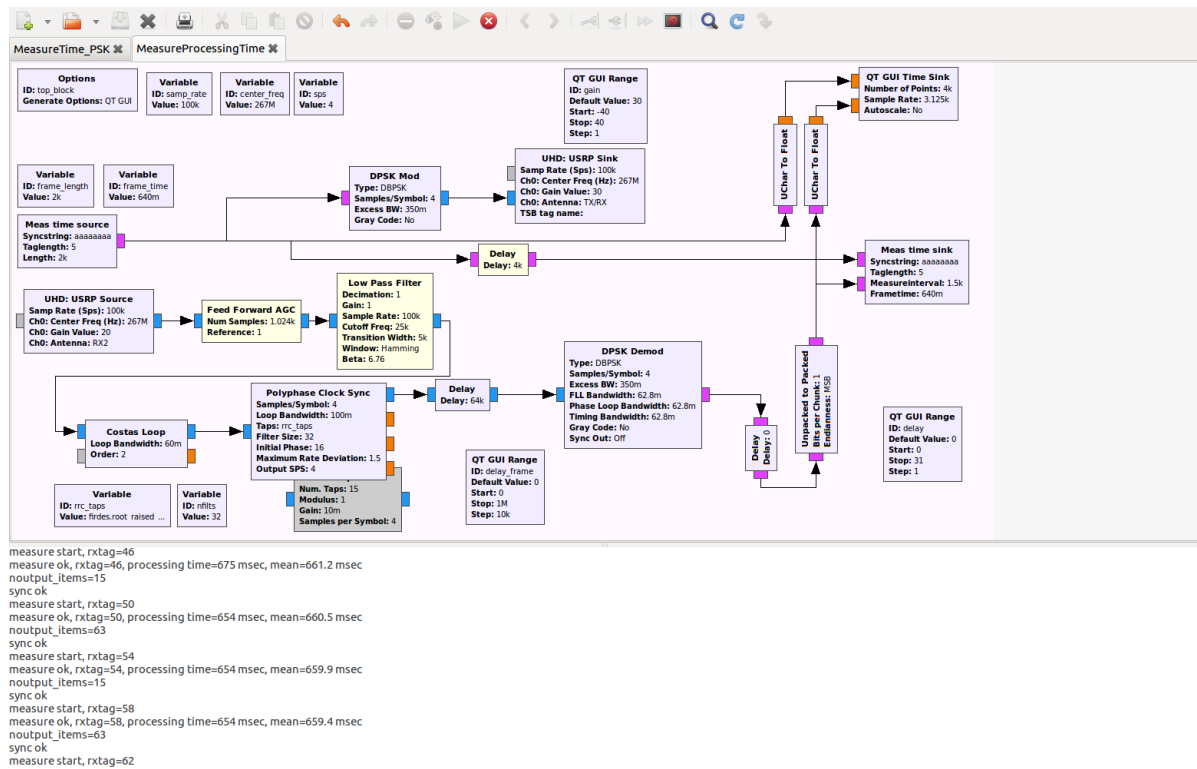

Figure 4.4: GNU flow graph used for measuring timing

The time source block creates content (in this case all 'a') and after a certain interval it will enter a unique tag number. This signal is directly fed into the meas time sink block and it is also modulated and sent via an UHD USRP Sink to the Ettus board. On the radio board the Rx ports is connected to the Tx port, and the signal is fed into the same flow graph. The Ettus is connected to the computer by USB 3. Once the signal re-enters the flow graph it travels through that in the Rx path there is a delay block after the DPSK demod block. This is because there is no bit synchronisation in this flow graph. This is done manually. The OOT module Meas time sink measures the time between the tags once the bits are synchronised. In the terminal space it returns the tag numbers of the transmitted block, the received block and the process time. It is shown in figure 4.4 (in the terminal space) that the process time varies.



Figure 4.5: Ettus loop back schematic

The variation in the measured time delay is a problem. This can be solved using an average measurement. Two extra delay blocks are introduced to the flow graph, one in the TX path and one in the RX path. These blocks delay a certain amount of samples. The delayed samples will translate in a time delay, if these measurements are fitted to a trend line a zero sample delay will correspond to the average time delay introduced by the GNU radio, the Computer, and the USB connection.

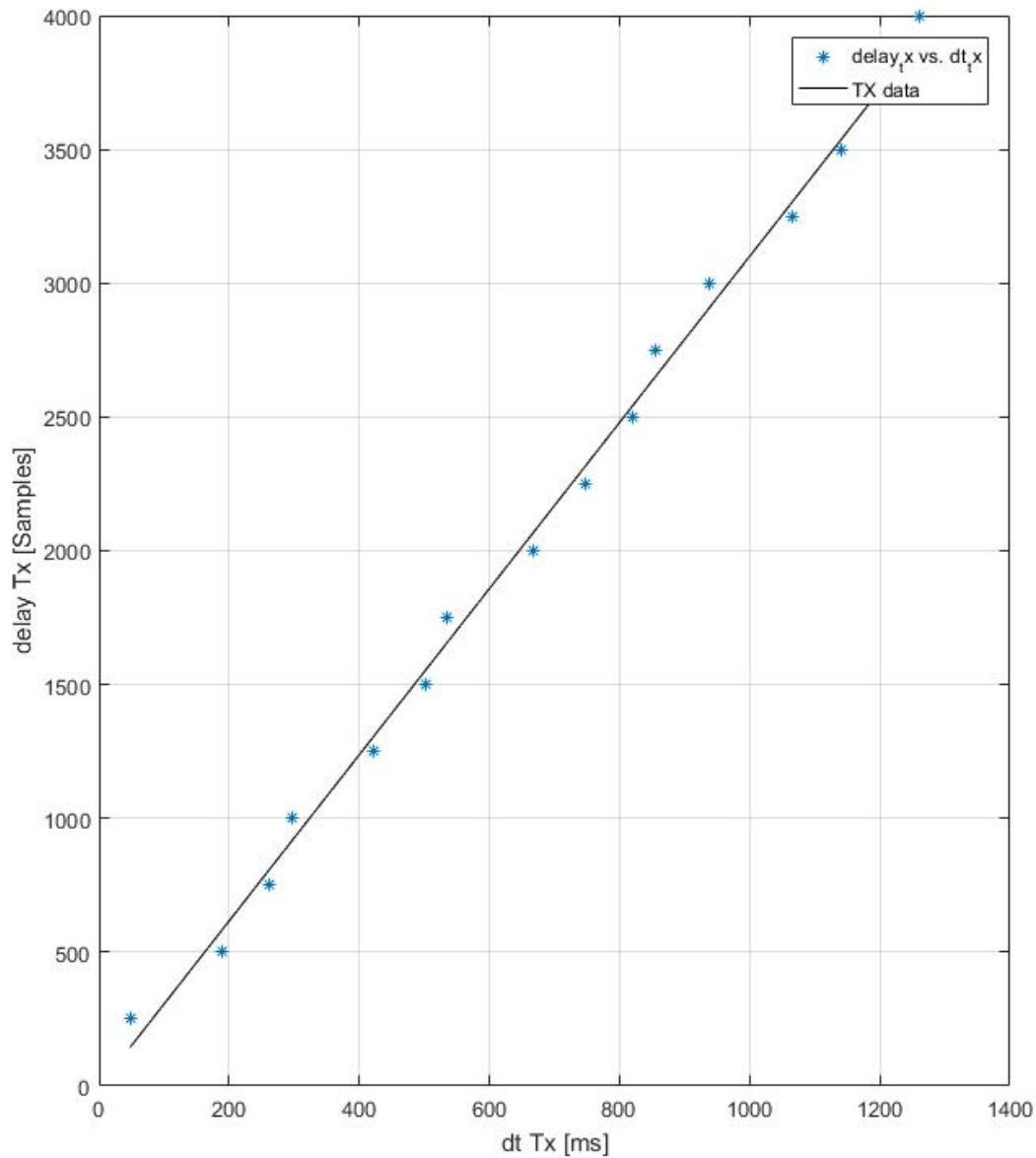

Figure 4.6: Delay in Tx path

$$Tx_{delay} = 3.1048 \cdot dt - 4.4875 \quad (4.3)$$

In the Tx path a delay of 1 second in time occurs at a sample delay of 3125 samples as can be seen in figure 4.6. This is because the time measurement sink compares bits and not samples, each sample after modulation contains four symbols and each symbol contains eight bits. The actual delay of 3125 samples results in a delay of 100kbits. After sixteen measurements a poly-fit curve was fitted to the data in MATLAB resulting in equation 4.3. The goal is to determine the latency on the outgoing signal from the PC through the UHD interface via USB to the Ettus board. This delay can be computed by setting Tx_{delay} equal to zero, resulting in a delay of 1.45 ms.

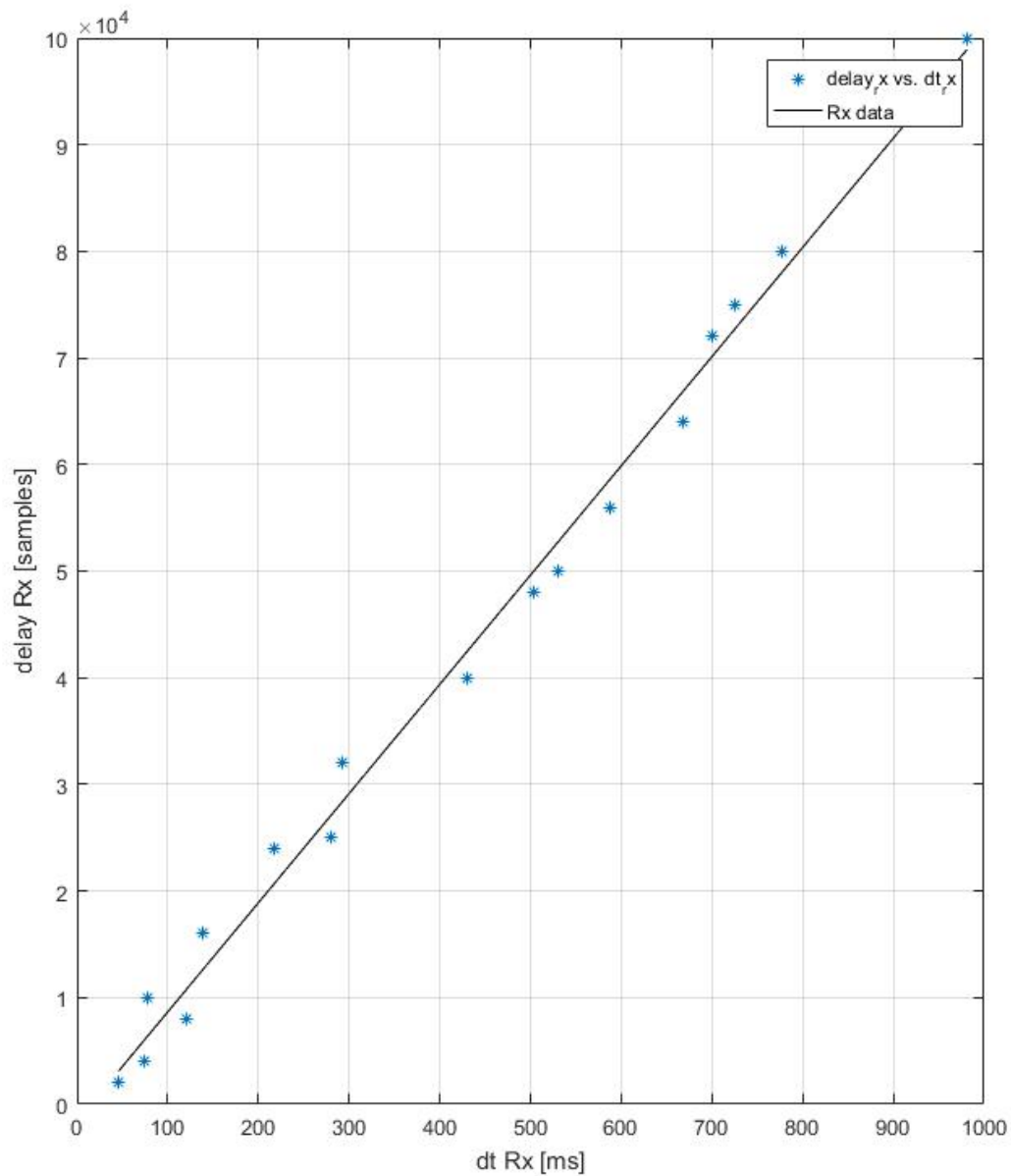

Figure 4.7: Delay in Rx path

In figure 4.7 the same technique is applied. Note that the stream where the delay is placed now contains one bit per sample instead of 32 bits per sample. As is clear from the plot a delay of 100k samples results in a time delay of one second. A trend line is fitted to the data and by setting the Rx delay in equation 4.4 to zero, the actual latency can be computed and is found to be 14.72 ms.

$$Rx_{delay} = 102.31 \cdot dt - 1506.3 \quad (4.4)$$

4.2.4. Link budget and Variable data rate

In this subsection the link-budgets will be presented and a variable bit rate strategy will be proposed. Hereafter a final data throughput will be determined in order to investigate if requirement BRK-SF-SYS-001 can

be complied with.

In table 4.9 the link budget for different bit rates is presented, the colour indicates if this link budget is sufficient to accommodate the corresponding modulation. The bandwidth is constant, only by choosing a denser modulation the bit rate is increased. In equation 4.5 the link budget equation can be found from [8]. $P_{EIRP} = G_{at} * P_{Tx}$, L_{FS} is the free space loss, G_{AR} is the receiving antenna gain, T_{sys} is the temperature of the receiving system. L_P , L_m and L_A are respectively the polarisation loss, multi-path loss and atmospheric attenuation. Furthermore the Boltzmann constant is represented by k ($1.38 \cdot 10^{-23} J/K$). The data rate is also of influence on the signal to noise ratio, and is represented by R . Note that all inputs should be in dB, when using this form of the link equation.

$$\frac{E_b}{N_0} = P_{EIRP_{dBm}} - L_{FS_{dB}} + G_{AR_{dB}} - L_{P_{dB}} - L_{m_{dB}} - L_A - (kTB)_{dB} \quad (4.5)$$

In table 4.5 the satellite payload parameters are listed. Where the power amplifier and circuit loss are values whom are based on experience from previous missions, the system temperature is given by the satellite bus provider.

Table 4.5: Satellite S&F system parameters

Parameter description	[-]
System temp	749.8 K
Antenna gain	0 dB
Power amp	2.5 W
LNA	-
Circuit loss	1 dB

In table 4.6 the system parameters of the terminal are presented. The antenna gain was measured and will be presented in chapter 5, concerning the power, the design value is used. The circuit loss is based on experience from previously designed systems by the 982SQN.

Table 4.6: Terminal system parameters

Parameter Description	[-]
system noise	-156.16 dB
Antenna gain	8 dB
Power amp	5 W
LNA	-
Circuit loss	1 dB

Concerning the free space loss, these values are presented in table 4.7. The numbers are generated using equation 3.4 to express the elevation as a function of the range (from observer to satellite). The range functions as input to equation 4.6. Note that the free space loss is dependent on the frequency through λ . Therefore the loss is slightly different for uplink (312MHz) and downlink (273MHz).

$$L_{FS} = 20 \cdot \log \left(\frac{4 \cdot \pi \cdot R}{\lambda} \right) \quad (4.6)$$

Table 4.7: Free Space loss as function of elevation

Elevation[degree]:	10	20	30	40	50	60	70	80	90
Ls down[dB]: @ 273MHz	147.39	144.63	142.43	140.75	139.47	138.55	137.92	137.54	137.43
Ls up[dB]: @312MHz	148.55	145.79	143.59	141.91	140.63	139.71	139.08	138.71	138.59

The remaining loss factors are listed in table 4.8, the Polarisation loss (linear to circular). A multi-path loss is accounted for and estimated at 2 dB. The atmospheric loss is small but can grow significantly when atmospheric scintillation occurs; as explained in chapter two operations will be suspended during scintillation events. However, Scintillation is closely related to the atmospheric behaviour, the attenuation computed here is based on the terrestrial weather.

Table 4.8: External losses

Noise description	Noise figure in[dB]
Polarisation loss	3 dB
Multipath loss	2 dB
Atmospheric loss	0.1-0.01 dB

All parameters are characterised and the link-budget can be calculated for up and down-link. Four different data rates are used to result in the values in tables 4.9 and 4.10. The data rates are based on the usage of BPSK, QPSK 8-PSK and 16-PSK in a 25KHz bandwidth at ideal spectral efficiency. The specific S/N requirement per modulation scheme can be found in table 4.12 and is calculated using the equations listed in table 4.1. The colour represents the feasibility of the combination of bit rate and elevation. Green represents possible and red impossible thresholds can be found in table 4.11. While constructing these link budgets a margin of 3dB is taken into account to deal with unforeseen losses.

Table 4.9: Link budget as function of data rate and elevation angle for satellite to ground communication

Elevation[degree]:	10	20	30	40	50	60	70	80	90
Eb/N0 @ 25 kBit/s[dB]	11.7	14.4	16.6	18.3	19.6	20.1	21.5	21.5	21.6
Eb/N0 @ 50 kBit/s[dB]	8.65	11.4	13.6	15.3	16.6	17.5	18.1	18.5	18.6
Eb/N0 @ 75 kBit/s[dB]	6.9	9.6	11.8	13.5	14.8	15.7	16.4	16.7	16.8
Eb/N0 @ 100 kBit/s[dB]	5.6	8.4	10.6	12.3	13.6	14.5	15.1	15.5	15.6

Table 4.10: Link budget as function of data rate and elevation angle for ground to satellite communication

Elevation[degree]:	10	20	30	40	50	60	70	80	90
Eb/N0 @ 25 kBit/s [dB]	13.2	16	18.2	19.9	21.1	22.1	22.7	23	23.2
Eb/N0 @ 50 kBit/s [dB]	10.2	13	15.2	16.9	18.1	19	19.7	20	20.2
Eb/N0 @ 75 kBit/s [dB]	8.4	11.2	13.4	15.1	16.4	17.3	17.9	18.3	18.4
Eb/N0 @ 100 kBit/s [dB]	7.2	10	12.1	13.8	15.1	16	16.7	17	17.2

Table 4.11: Colour scheme used in tables 4.9 and 4.10

25 kBit/s	50 kbit/s	75 kbit/s	100 kbit/s
<10.5	<10.5	<13.9	<18.5
>10.6	>10.6	>14	>18.6

Table 4.12: Link Budget required by modulation

Modulation	Spectral efficiency [Bit/s/Hz]	Bit rate [kbps] (@ B = 25KHz)	E_b/N_0 [dB]
BPSK	1	25	10.5
QPSK	2	50	10.5
8PSK	3	75	13.9
16PSK	4	100	18.5

From tables 4.9 and 4.10 it can be observed that operating in one single bit rate is either a waste of sufficient link quality or a waste of time. Therefore a variable bit rate is proposed which switches from BPSK to QPSK to 8-PSK and back if required. This is illustrated in figures 4.8. In these figures the spectral efficiencies of BPSK, QPSK and 8-PSK are taken into account, using a roll-off factor of 0.25.

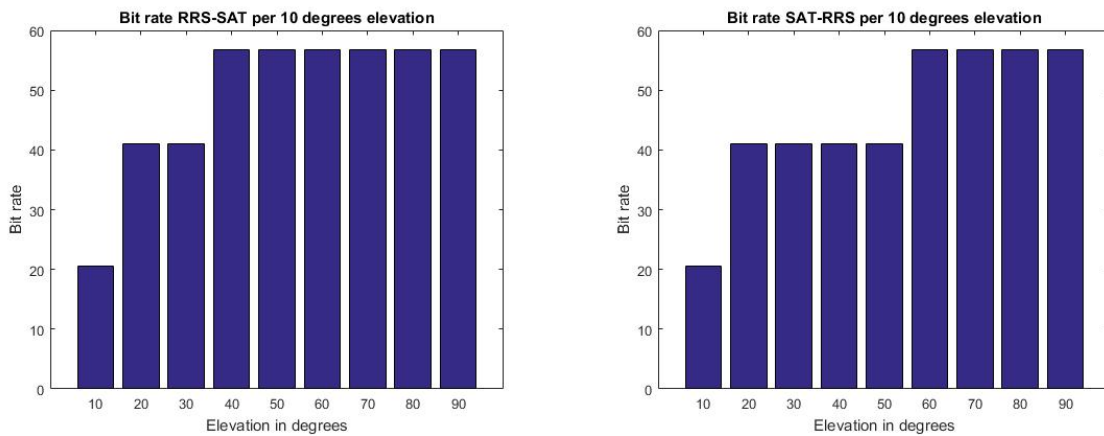

(a) Variable data rate uplink (ground to satellite) for half a pass (b) variable data rate downlink (satellite ground) for half a pass

Figure 4.8: Variable data rate proposal for both up and downlink

4.2.5. Actual data volume in one pass

The Link-budget, spectral efficiency and time delay are determined such that the total data volume in a 10 min pass can be calculated. Using a variable data rate a simple simulation is built, dividing the satellite pass in 17 sections, each section representing an elevation increase of 10 degrees. In a 10 min pass each section takes 35s. The simulation runs a loop counting packages and the time as presented in figure 3.9. Once the time reaches 35 seconds the next loop is commenced. Each loop represents a path delay as presented in table 4.4 and a certain bit rate as is presented in figures 4.8.

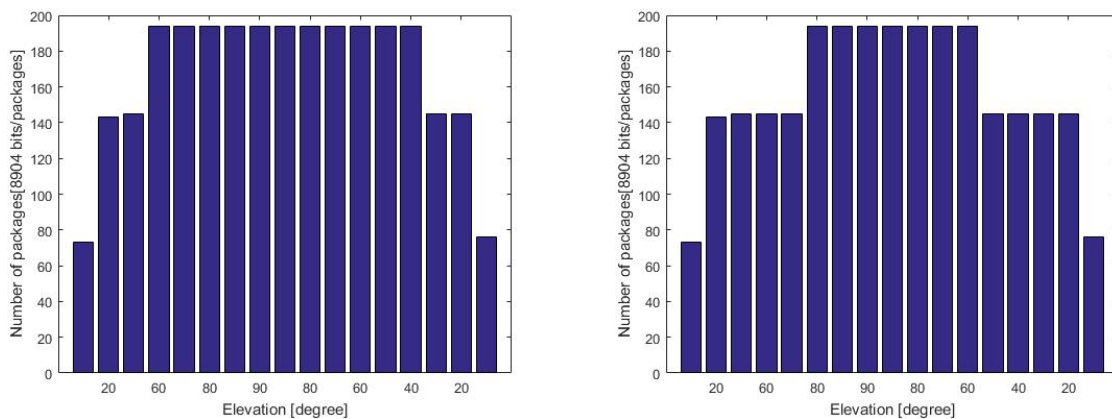

(a) Total amount of packages that can be sent per elevation angle uplink (b) Total amount of packages that can be sent per elevation angle downlink

Figure 4.9: Package count for up and downlink per elevation angle

Based on a number of assumptions which are listed below;

- Ideal package length is constant (8904 bits) 3.5
- BER is constant (10^{-6})
- Process time in the satellite and terminal are equal
- Acknowledgement size is constant at 80 bit
- Roll-off is 0.25
- Ideal satellite passage is used 0-90 degrees elevation

The total data volume can be observed in table 4.13. It is shown that the data volume is not the required 5Mbyte as stated in requirement BRK-SF-SYS-001. Evaluating the assumptions, the equal process time in terminal and satellite is the only assumption which has a large impact on the simulation outcome. Due to the lack of proper resources the timing experiment explained in section 4.2.3 could not be performed on the actual satellite hardware. By running the exact same test on a raspberry pi (simulating the space crafts S&F CPU) it is observed to be 18 times slower. However there is no further investigation on where the delay takes place, the actual number crushing in the PI or the USB2 connection. Furthermore the radio architecture on the satellite side is different to the SDR layout. Therefore assuming that the satellite is 18 times slower the respective data volumes result in 2.52Mbyte (sat-ter) and 1.44 Mbyte (ter-sat).

Table 4.13: Total data volume at channel at BER 10^{-6}

Operation	Total number of packages	number of re-transmissions	Number of use full packages	Total data volume
terminal - satellite	2630	47	2583	2.87 Mbyte
satellite-terminal	2462	44	2418	2.69 Mbyte

4.3. Design verification and requirements check list

In this section a short description will be provided per requirement explaining the manner in which it is incorporated in the design. This section will be concluded with a checklist 4.14.

- *BRK-SYS-RRS-011*
The mass budget as presented in table 3.16 indicates that it is well within the 10kg limit stated in this requirement.
- *BRK-SYS-RRS-012*
The volume budget as presented in section 3.4.2 states that the volume will most likely be somewhere between 12 to 16l, well within the limites stated in this requirement.
- *BRK-SYS-RRS-021* A link margin of 3dB is accounted for in the link budget, this will cope with unforeseen disturbances, furthermore the ARQ error control will indicate lost packages in case of a link interruption. It will log automatically all missing or never arrived packages.
- *BRK-SYS-RRS-022*
A preliminary HMI dashboard layout is presented in section 3.3.5 making use of a touchscreen. Which will displaying relevant information to the user.
- *BRK-SYS-RRS-023*
The power budget as presented in 3.4.2 is calculated to comply with this requirement. Sizing the battery to last at least 100 min operational time.
- *BRK-SYS-RRS-024*
Choosing an SDR platform gives us a wide range in available wave-forms. Furthermore the Ettus board UHD interface provides variable gain settings. The power amplifier should be able to accommodate frequency and phase modulation which will also not be used because of constrains on the satellite side.
- *BRK-SYS-RRS-025*
The antenna measurements including the HPBW angle are presented in chapter five. The magnitude

of the HPBW Angle of the antenna depends use of a reflector and the number of directors.

- *BRK-SYS-RRS-026*
The terminal contains a USB interface to cover this requirement.
- *BRK-SF-SYS-001*
A single pass message transfer, investigated earlier in this chapter is not the required 5 Mbyte. This requirement stated a TBC and as presented in this chapter the achievable data rate is just over half the value the requirement demands, this should be either be re-designed or be discussed with the stakeholder.
- *BRK-SYS-RRS-033*
The NUC has an option to include an SD card of any size.
- *BRK-SYS-RRS-034*
This can be seen in the preliminary HMI dashboard design presented in figure 3.15.
- *BRK-SYS-RRS-035*
The link-budget is calculated between 10 and 170 degrees elevation. This requirement originates from the assumed satellite antenna pattern. This value has had no update therefore this requirement is interpreted as a constraint.
- *BRK-SF-SYS-014*
The actual message packages layout (header, preamble etc.), could help determining if it is indeed a genuine S&F message. Other than the package encoder and package decoder block in Gnu radio there are no design choices made in this respect.
- *BRK-SYS-RRS-042*
Using multiple terminals in the same footprint is possible (see section 4.1), however due to the limited capability of the satellite and the ITU restrictions no techniques such as MIMO are possible.
- *BRK-CON-007*
See Frequency support-ability form in appendix D The allocated channel is described by requirements BRK-SYS-RRS- 061, 062 and 063. The form in appendix D covers this requirement but will require a more detailed description of the system.
- *BRK-SF-SYS-061*
See Frequency support-ability form in appendix D
- *BRK-SF-SYS-062*
See Frequency support-ability form in appendix D
- *BRK-SF-SYS-063*
See Frequency support-ability form in appendix D

In table 4.14 the requirements checklist is presented. As can be observed not all requirements have a checkmark. Some requirements need further investigation, others need a compromise between design and stakeholder. The driving BRK-SF-SYS-001 is one of the requirements that probably needs either a redesign of the message handling protocol or a lower required data volume.

Table 4.14: Requirements check list

Req number	Short description	✓
BRK-SYS-RRS-011	Mass Req.	✓
BRK-SYS-RRS-012	Volume Req.	✓
BRK-SYS-RRS-021	Robust link	✓
BRK-SYS-RRS-022	Easy operations	✓
BRK-SYS-RRS-023	Battery life	✓
BRK-SYS-RRS-024	Flexible waveform	✓
BRK-SYS-RRS-025	Small antenna Footprint	✓
BRK-SYS-RRS-026	Interface req.	✓
BRK-SF-SYS-001	5 MByte req.	
BRK-SYS-RRS-033	Data memory	✓
BRK-SYS-RRS-034	Transfer window	✓
BRK-SYS-RRS-035	Min elevation	✓
BRK-SF-SYS-014	Desired/undesired messages	✓
BRK-SYS-RRS-042	Multiple terminals	✓
BRK-CON-007	ITU regulations	✓
BRK-SF-SYS-061	Up-link freq. req.	✓
BRK-SF-SYS-062	Down-link freq. req.	✓
BRK-SF-SYS-063	Bandwidth req.	✓

5

Test Setup and Results

The previous chapter was inconclusive on the data rate achievable, mainly because it is near impossible to calculate the lead time in the signal processing. Therefore a test is conducted and the results are presented in this chapter. First some performance tests on the Ettus B205 mini were done. Thereafter the stop and wait ARQ protocol is explained and put to the test. Using the hardware and a satellite link emulator the data throughput can be determined. This chapter will be concluded by testing a Doppler correction method (both on Tx and Rx) using GNU radio and the SGP4 model output.

5.1. Performance USRP Ettus Mini-i B505

The UHD: USRP® source/sink is the interface block used by GNU Radio to communicate with a USRP® designed by Ettus research. This hardware drive has a number of settings which should be investigated. There are some settings that only apply to larger Ettus Boards, like time source and clock source. The more interesting settings for this project are in the RF tab shown in figure 5.1. The centre frequency is equal to the carrier, the gain value in the source block is a LNA gain, and the antenna specifies the RF connection. There are three RF connections on the B205 mini as can be observed in 3.12, one Rx port one Rx/Tx port and a reference port.

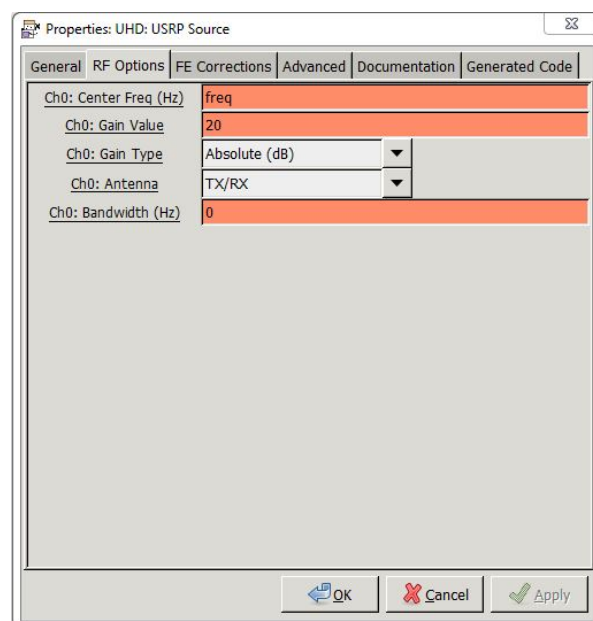

Figure 5.1: RF tab of the UHD interface

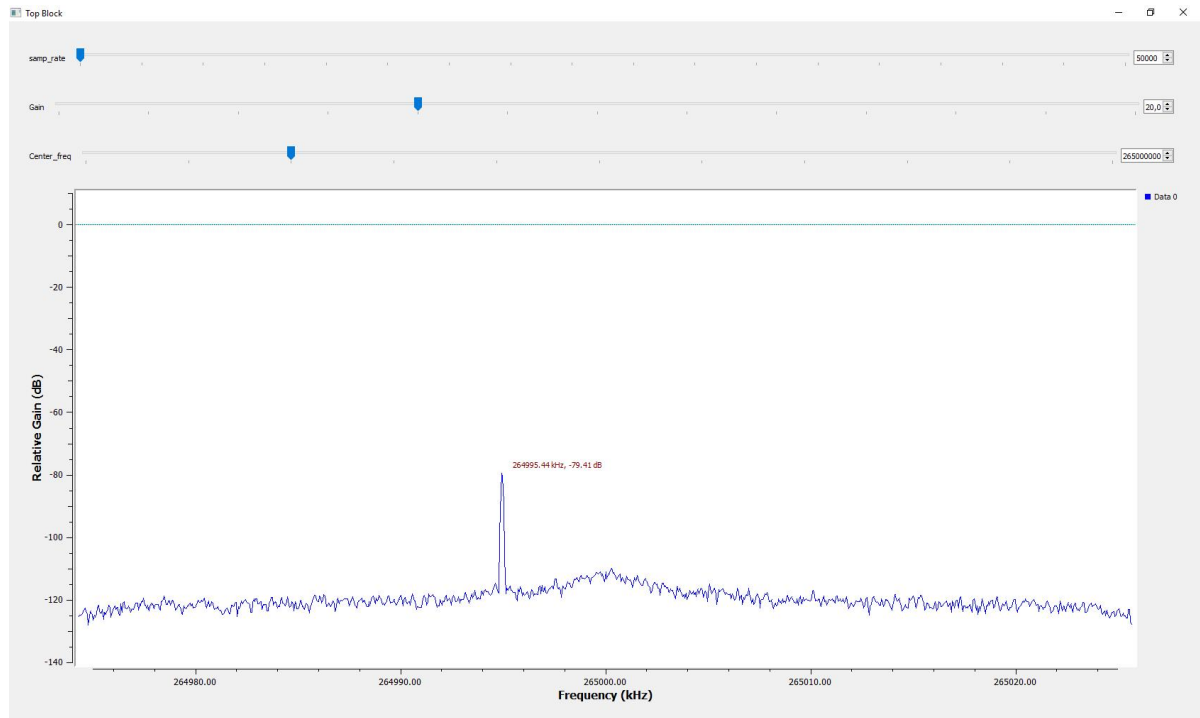

Figure 5.2: GUI showing the frequency plot of the measurement

In order to get an understanding on the gain level that should be entered in the receiving path a measurement was conducted. The GRC flow-graph contains the UHD source, a frequency sink and variable sliders controlling the centre frequency, gain and sample rate. An image of the GUI can be seen in figure 5.2. The signal is generated using an Agilent E4438C rated to generate carrier signals between 250 kHz and 2GHz. While the carrier and the input power were considered constant the gain is varied between 0 and 60 using intermediate steps of 5 dB. With medium averaging in the frequency plot engaged, the noise floor can be measured from the plot. The last column gives the signal to noise ratio, which is not simply the difference between the signal power and the noise power. GNU Radio distributes the power over the number of bins shown in the plot (in this case 1024). Noise is spread over 1023 bins while the signal is pressed into one bin (Blackman-Harris window). Using this information the S/N ratio is determined and presented in the last column of table 5.1.

Table 5.1: Received signal strength Ettus B205 mini

Gain setting [dB]	Signal power [dBm]	Signal Freq[kHz]	Measured signal strength [dB]	Noise floor [dB]	S/N [dB]
0	-80	264990	-98.25	-122.7	-5.65
5	-80	264990	-94.84	-120.4	-4.54
10	-80	264990	-89.43	-119.34	-0.19
15	-80	264990	-84.18	-118.45	4.17
20	-80	264990	-79.41	-118.67	9.16
25	-80	264990	-74.42	-116.36	11.84
30	-80	264990	-68.97	-115.72	16.65
35	-80	264990	-62.62	-119.12	26.40
40	-80	264990	-58.53	-117.31	28.68
45	-80	264990	-53.31	-114.83	31.42
50	-80	264990	-48.55	-108.91	30.26
55	-80	264990	-44.46	-108	33.44
60	-80	264990	-39.7	-103.24	33.44

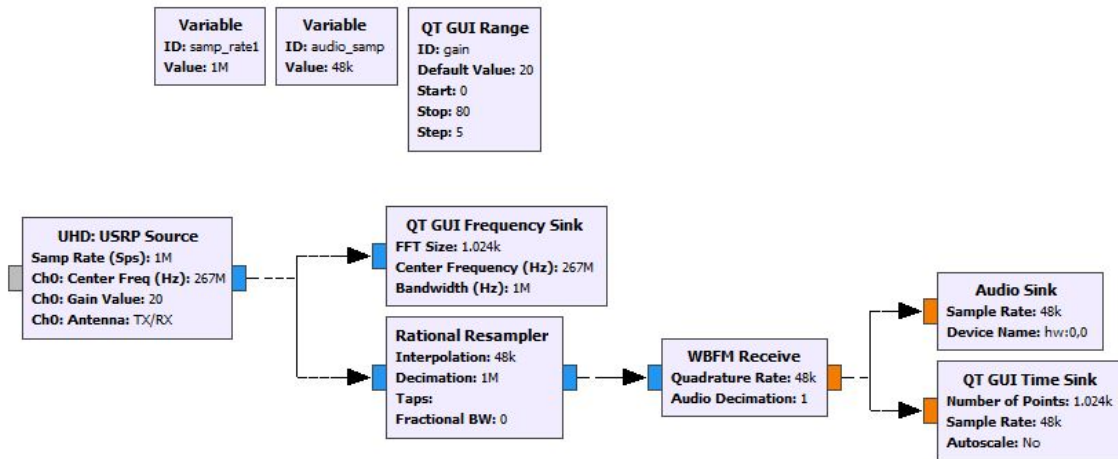

Figure 5.3: SINAD measurement flow graph

A SINAD ($\text{Signal} + \text{noise} + \text{distortion} / \text{noise} + \text{distortion}$) measurement is performed to investigate the receiver performance on FM modulated signals. FM was chosen because this modulation is supported by the Agilent E4438C signal generator, and the HP 89038 Audio Analyser. The test setup is shown in appendix C figure C.1 a Schematic representation can be seen in figure 5.4. The GNU radio flow graph is presented in figure 5.3, The carrier frequency is set to 267MHz and is first sampled at 1 MSPs, this is re-sampled to match the frequency of the audio output. Via the audio output of the computer the signal is presented to the HP audio analyser. The volume is set to it's maximum value as is the gain in the UHD interface. While performing the measurements the following steps are taken.

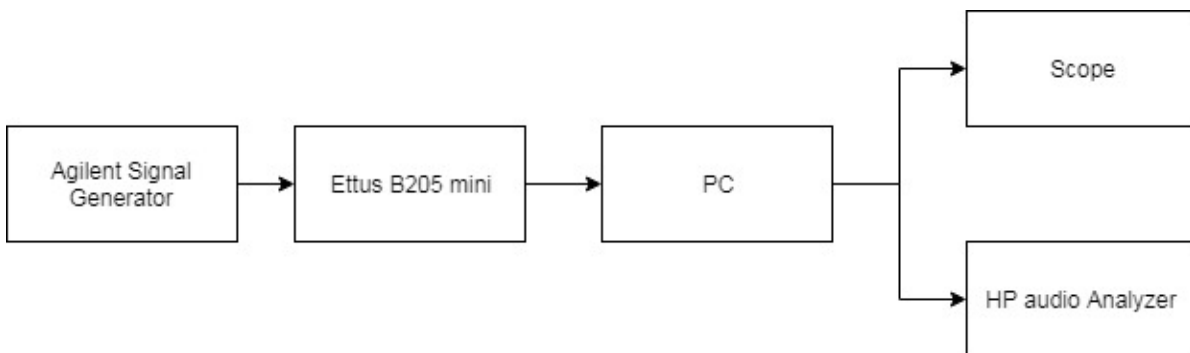

Figure 5.4: Schematic representation of the SINAD measurement setup

1. Set the volume and gain to maximum (UHD gain 75dB).
2. Set the signal generator to modulate a tone (1kHz) in FM.
3. Run the flow graph
4. Throttle down the signal on the signal generator until the audio analyser indicates a SINAD of 12dB [11]

Table 5.2: SINAD measurement result

Gain UHD [dB]	Sample Rate [MHz]	SINAD [dB]	Input power [dBm]
75	1	12	-115.45

In table 5.2 the result of the SINAD measurement can be observed. To achieve a value of 12dB the input power

must be at least -115.45 dBm. This should be interpreted as follows: " if the radio receives a signal of -115.45 dBm it will still be able to demodulate its content".

5.2. Antenna Characteristics

As described in chapter 3 the antenna used in this design is the Harris AT001, which has a crossed Yagi design in four configurations, as presented in table 5.3. It is important to know the size of the Half Power Beam Width (HPBW) angles to account for misalignment problems. Furthermore it is important to link this information to the validity of the TLE information. It is also important to validate the realised gain will be determined.

1	Only radiated elements
2	Radiated elements and reflector elements
3	Radiated elements, reflector elements and 3 directors
4	radiated elements, reflector elements and 6 directors

Table 5.3: Antenna configurations

The antenna is characterised twofold with a simulation in 4nec2 using the moment method [5] and with a measurement in a rectangular anechoic chamber (EMI). These simulations and tests will be performed at two frequencies, 270 Mhz (around the downlink frequency) and 310 Mhz (around the uplink frequency). The test setup can be seen in figure C.2 in appendix C and in figure 5.5, on the foreground the antenna in configuration 3. At the background before the table the radiated reference element can be seen. This is a dipole which is linearly polarised, the measured antenna (Harris AT001) is circularly polarised. The distance between the antenna and the reference element is 3.5m, this distance was not changed between the two measurements.

Table 5.4: Test results 310Mhz

	Test Frequency 310MHz		
mono-pole:	-57dBm		
configuration	gain 0deg [dBm]	left -3dBm [°]	right -3dBm [°]
1	-60		
2	-53.6	30	35
3	-51	24	26
4	-49.9	19	24

In table 5.4 the uncorrected test results for the 310 MHz measurement are presented. From column two it is clear that transitioning from configuration 1 to configuration 2 results in the largest increase in gain.

Table 5.5: Test results 270Mhz

	Test frequency 270MHz		
mono-pole:	-50dBm		
configuration	gain 0deg [dBm]	left -3dBm [°]	right -3dBm [°]
1	-53		
2	-47.6	24	20
3	-46.6	23	22
4	-45.6	22	21

In table 5.5 the uncorrected test results for 270 MHz measurement are presented.

Realised gain calculations can be performed in two ways either with the two or three antenna method. The problem is that the actual gain of the radiating antenna is not a known value. To determine the gain of the radiator the two antenna method is used. Based on the assumption that the both transmitting and receiving antenna have the same gain ($G_{0t} = G_{0r}$) [3]. This technique makes use of the Friis transmission formula 5.1. Other assumptions include that only two antennas are used and they are of the same polarisation. Once the Gain of the transmitting antenna is determined the realised gain of the Harris AT0001 can be calculated. The setup can be seen in figure C.3 in appendix C. From this picture it is clear that the radiating antenna (dipole) and the receiving antenna (mono-pole with a ground plane) are not the same. Although according to the theory [3] they should both have a gain around 0dB and are both linearly polarised.

$$\frac{P_r}{P_t} = \left(\frac{\lambda}{4\pi R} \right)^2 \cdot G_{0t} \cdot G_{0r} \cdot |\hat{\rho}_t \cdot \hat{\rho}_a|^2 \quad (5.1)$$

Which can be rewritten in decibel form to ($|\hat{\rho}_t \cdot \hat{\rho}_a|^2 = 1$ because it is assumed that the antenna's are polarisation-matched) :

$$G_{0t} + G_{0r} = 20 \cdot \log_{10} \left(\frac{4\pi R}{\lambda} \right) + 10 \cdot \log_{10} \left(\frac{P_r}{P_t} \right) \quad (5.2)$$

The measurement was conducted at 310MHz and 270MHz, all the input values can be seen in the list below:

- G_{0t} = gain of the transmitting antenna (dB)
- G_{0r} = gain of the receiving antenna (dB)
- P_r = received power [-57 dBm, -50dBm]
- P_t = transmit power [-20 dBm]
- R = antenna separation(3.4m)
- λ = operating wavelength (0.967m and 1.111m)

The equation can be slightly rewritten considering the assumptions and the power is given in dBm instead of Watt:

$$G_{0t} = G_{0r} = \frac{1}{2} \left(20 \cdot \log_{10} \left(\frac{4\pi R}{\lambda} \right) + P_r - P_t \right)$$

The gain of the transmitter used in this experiment was determined to be -2.05 dB at 310 MHz and 0.85 dB at 270 MHz which is expected to be roughly the right proportion because the dipole was tailored to 270 MHz. As the transmitting element gain is determined the measurement results can be corrected, using the link budget equation 5.3. Note that an extra loss is added, this is due to the connection on the AT001 which was worn out, and estimated on an additional -1dB of attenuation furthermore there is a difference in polarisation between the dipole and the cross yagi of -3dB, which is also accounted for in the L_{add} parameter.

$$G_{0r} = 20 \cdot \log_{10} \left(\frac{4\pi R}{\lambda} \right) - G_{0t} + P_r - P_t - L_{add} \quad (5.3)$$

The realised gain of the Harris AT001 is presented in table 5.6. Note the maximum gain in configuration 4 is not 11 dB as stated in the brochure, this is because it is given as dBic or as measured from an isotropic antenna which in reality does not exist. An extra correction factor of 2.15 dB should be accounted for when measuring with respect to an isotropic antenna. When added to the gain listed in table 5.6 the antenna matches the number given in table 3.3, which originates from the brochure [2].

Table 5.6: Realised gain and corrected HPBW angle of the Harris AT001 antenna

Antenna Configuration	Realised gain [dB] @ 310 Mhz	Realised gain [dB] @ 270 MHz	HPBW angle [°] @ 310 MHz	HPBW angle [°] @ 270 MHz
1	-1.05	1.85	-	-
2	5.35	7.25	78	54
3	7.95	8.25	60	56
4	9.05	9.25	53	53

In the data sheet [2] it is stated that the antenna has a HPBW angle of 60 degrees in configuration 4. The manufacture states that this is the HPBW angle using two sets of directors. In table 5.6 the corrected HPBW angles are presented. These angles are corrected due to the use of a different pivoting point. In figure 5.5 it can be observed that the pivoting point around which the antenna was rotated is not at the same position as the feeding elements (bold line). When performing Antenna measurements at close range this should be accounted for.

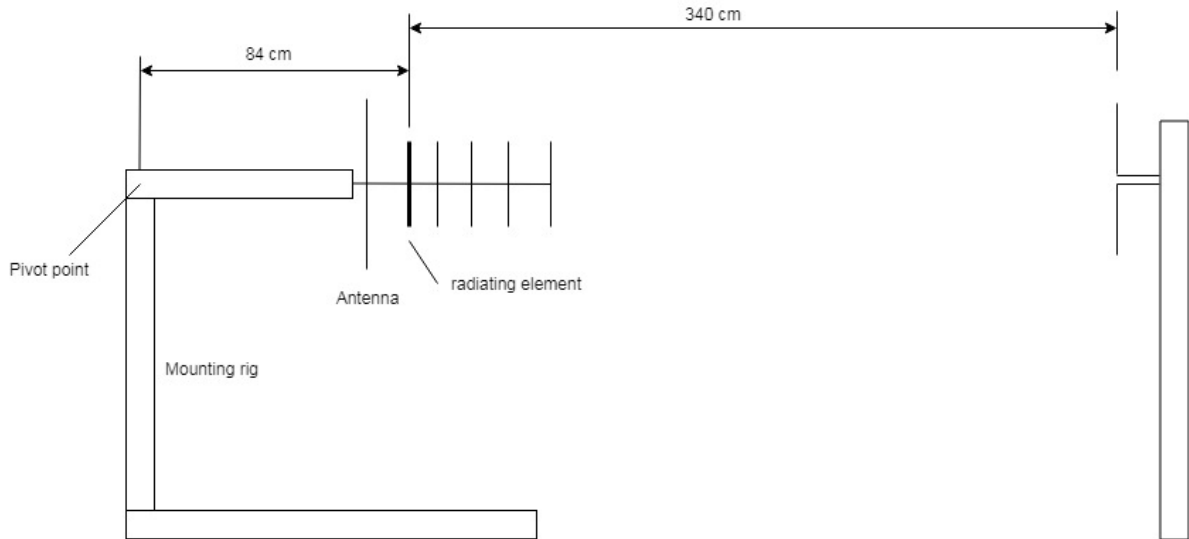

Figure 5.5: Schematic of the antenna measurement (not to scale)

the correction can be calculated using basic trigonometry, a simplified drawing can be seen in figure 5.6. The HPBW angle given in the specifications [2] is measured from the radiating element. A correction can be calculated, assuming an isosceles triangle, the angles alpha can be seen in table 5.6 last two columns.

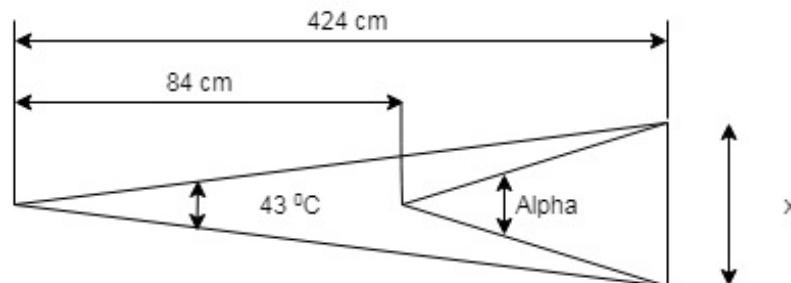

Figure 5.6: Simplified angle correction for offset in rotation (pivot) point

5.2.1. Antenna Model

4NEC2 uses the integral method of moments [3] to calculate the radiation pattern of any antenna shape [10]. The simulation tool offers several ways to enter an antenna shape, either by drawing or line coding. The program can calculate near and far field patterns, perform frequency sweeps and can optimise the design if the correct parameters are set. 4NEC2 also has a built in verification tool, this tool checks for segmentation errors and performs a geometry check.

In 4NEC2 there are two rules concerning segments. The first rule is that the segment should have a length of approximately $\lambda/20$, the second states that the segment length should be at least four times the wire thickness. If this is not the case 4NEC2 will automatically indicate to run a segment check. If one wants to

calculate the radiation pattern a voltage source should be added, these always go in the centre of a segment never at the end. Furthermore the voltage source is ideal and its amplitude makes no difference for the antenna gain or radiation pattern.

As can be observed in table 5.6 only configuration 3 and 4 achieve a gain of 8dB therefore these two configurations were modelled in 4NEC2. The antenna layout of each configuration can be observed in figure 5.7

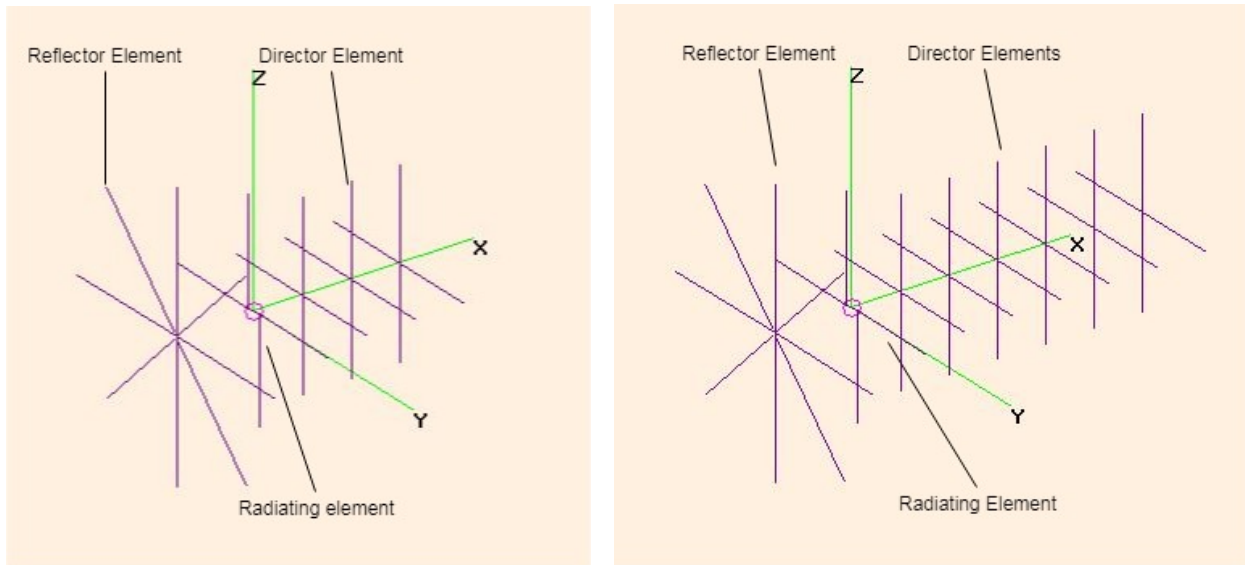

(a) Antenna model configuration 2

(b) Antenna model configuration 4

Figure 5.7: Antenna configuration modelled in 4NEC2

The resulting gain patterns are presented in figure 5.8 and 5.9. The green lines indicate the simulated HPBW angles the magenta coloured line indicates the angle measured in the anti clock wise direction (to the left).

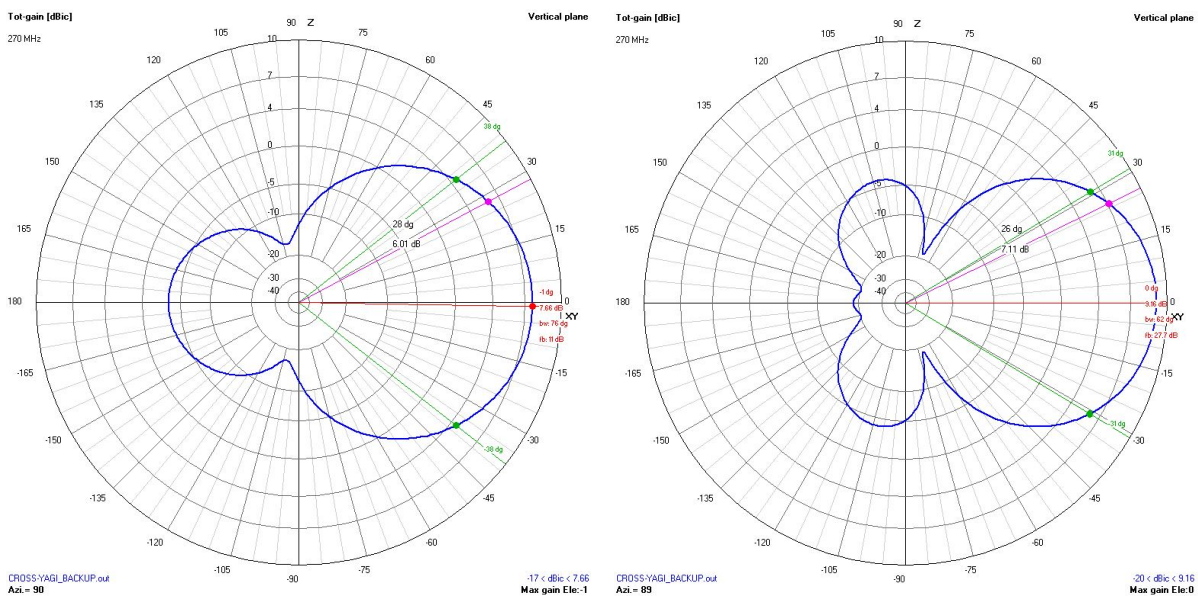

(a) Antenna Pattern configuration 3 @ 270 MHz

(b) Antenna Pattern configuration 4 @ 270 MHz

Figure 5.8: Antenna Pattern modelled at 270 Mhz

In figure 5.8a the antenna in configuration 3 is modelled at 270 Mhz. As can be observed there is a 10 degree discrepancy between the simulated value and the measured value. The gain of 7.66 dB at zero degrees is close to the measured 8.25 dB. In figure 5.8b the antenna in configuration 4 is modelled at the same frequency. The discrepancy between the measured value and the simulated value is only 4 degrees and the gains at zero degree are only 0.9 dB separated between measured and simulated values. The model represents the test results closer when more elements are added.

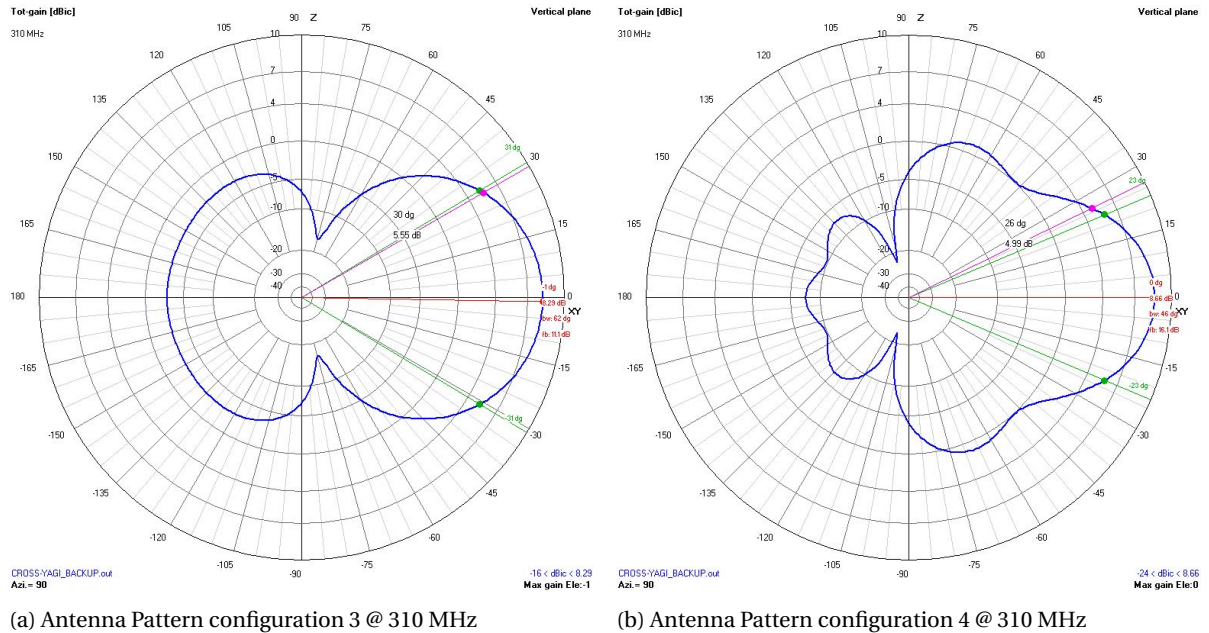

Figure 5.9: Antenna Pattern modelled at 310 MHz

In figure 5.9a the antenna is modelled in configuration 3 at 310 MHz, the discrepancy between the measured gain and the simulated maximum gain is only 0.34 dB where the HPBW angle difference is 3 degrees. Concerning the antenna model in configuration 4 at 310 MHz the difference in gain is 0.39dB, which is very small, and the discrepancy in HPBW angle is 1 degree. The theory seems to represent the test results closer in this frequency range as compared to the 270MHz measurements.

This pattern is represented as a two dimensional plot where in reality it is three dimensional. These plots are all at 0 degrees elevation. The simulated three dimensional pattern of the antenna in configuration 4 at 310MHz can be observed in 5.10 During the measurement the antenna was supported on a stiff structure, however the horizontal alignment between the radiating dipole and the AT001 antenna was not measured. Furthermore the antenna itself is not very stiff, due to its light weight structure. As can be observed in appendix C, figure C.2 the antenna in configuration 3 is already susceptible to deflection, in configuration 4 the deflection is even larger. This results in measurement errors and could explain the difference between the measured values and the simulated values. In figure 5.10 it can be seen that the angle is measured from the source (in the centre of the radiating element, magenta circle). During the measurement the pivoting point, around which the antenna was rotated, lays behind the reflecting element. This is most probably the largest contribution to the error.

CROSS-YAGI_BACKUP.out

Tot-gain

310 MHz

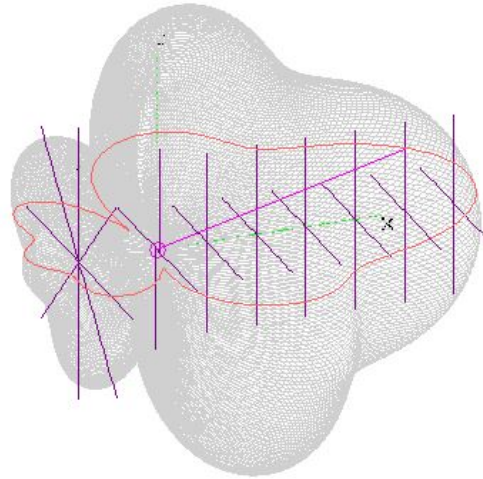

Elev. : 24

Axis : 0.5 mtr

Azi. : 201

Figure 5.10: 3D representation of the antenna pattern configuration 4 at 310MHz

According to figure 3.20 the satellites position deviates 20 degrees from its actual position, 26 days after the last time a TLE was uploaded. Note this plot is generated during a solar minimum, during a solar maximum this deviation could be reached in less time. This means after 26 days the user loses 3 dB signal when pointing at the precise location of the simulated position of the satellite. Timing issues could cause more severe problems, the user could miss the satellite completely.

5.3. Receiver path test

In this section the receiver path will be broken down in two parts, the signal recovery and the actual information decoding. Both a signal and the channel will be simulated, since the satellite is not yet in orbit.

5.3.1. Signal Recovery

During a transmission several types of distortions are added to the signal carrying the message. In order to properly extract the information from this signal these distortions need to be filtered out of the signal. GNU Radio offers a number of channel models, these models can be used to simulate the distortion in the communication channel.

First a simple channel model is used in order to check how the RX design as presented in figure 3.19 will react to various distortions. The channel model block in 5.11 can add AWGN, timing offset and frequency distortion to the signal. The AWGN is entered as a voltage, this corresponds to a standard deviation of the noise. The frequency offset is a fraction of the flow graph sample rate. Thus 0.10 is a tenth sample rate offset in

frequency. Epsilon can be set to a time offset between samples to emulate the different rates between sample clock offsets. The taps can be used to simulate multi-path loss and the seed field indicates the random number generator input for the noise source.

The flowgraph is build from left to right (figure 5.11), starting with a random source generating unsigned char characters (0 to 255) representing 8 bits. This is modulated by a constellation modulator which provides flexibility in terms of the modulation used (in this test QPSK). The modulated complex stream is then multiplied with a carrier frequency which is normally done by the UHD interface. The signal is passed through the channel model. In order to change the distortions while the simulation is running sliders are added, which control the timing off-set, frequency off-set, and the AWGN. The stream is passed through a throttle which limits the CPU use, which is normally limited by the UHD (or any hardware interface). The following three blocks represent the RX path signal recovery chain.

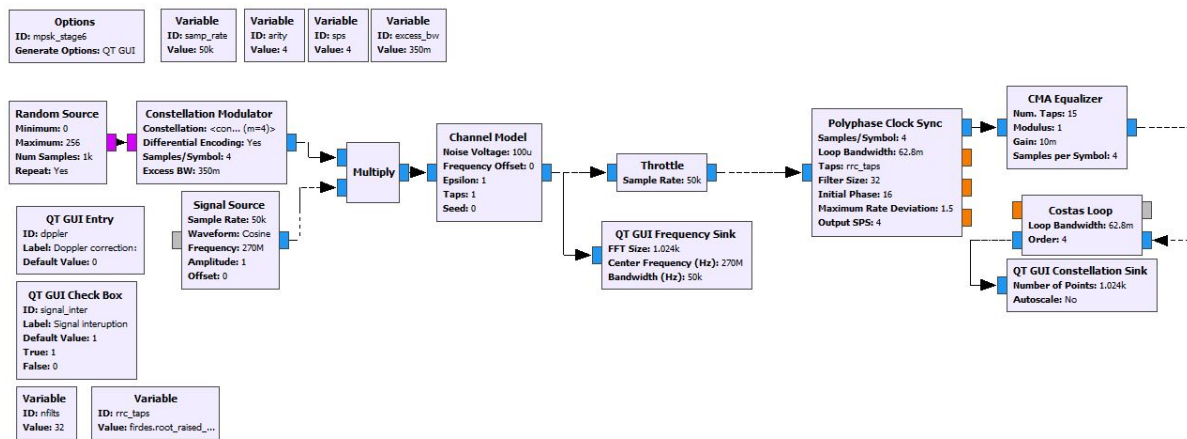

Figure 5.11: Simple channel model

First the noise should be set correct. The worst possible SNR in which the terminal should operate is 11.7 dB as determined in chapter 4. The frequency plot in the bottom of figure 5.12 can be used to set the desired signal to noise. Note that GNU radio plots the energy per bin. In this particular experiment the frequency plot contains 1000 bins (which corresponds to the number of points in the plot). The signal is plotted over 200 bins and the noise over 800 bins. If the conversion is applied a SNR of 11.7 is reached with a noise level of -47.7dB and a signal level at -30dB. This corresponds to a standard deviation in the noise of 0.34. Furthermore note that in the frequency plot medium averaging is applied for display purposes.

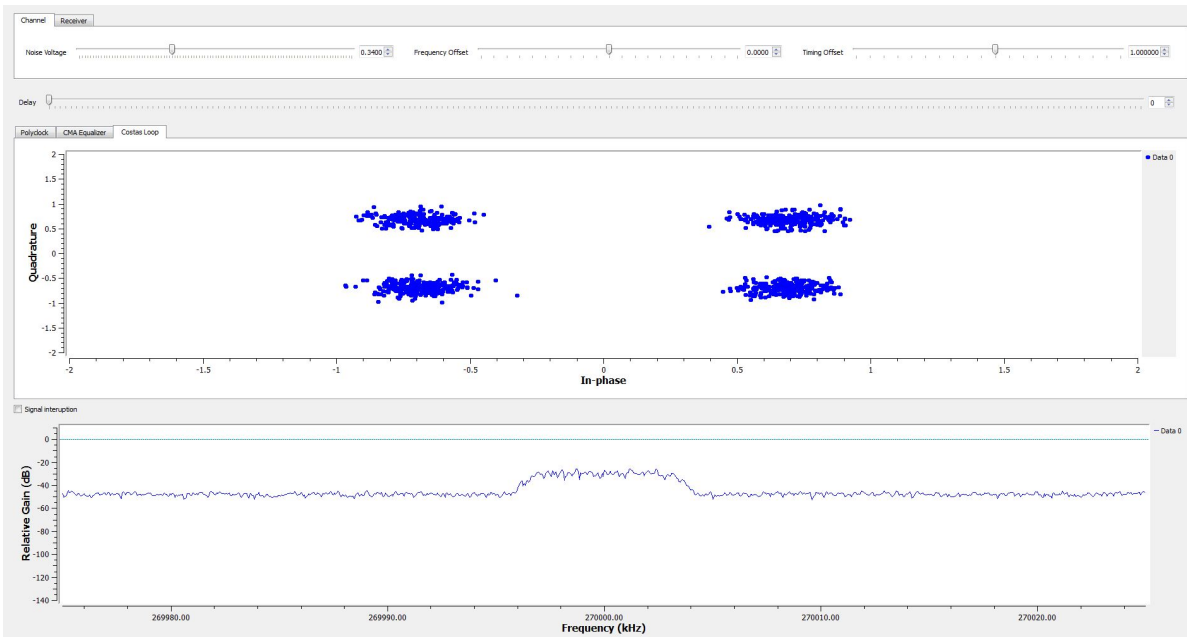

Figure 5.12: Experiment only AWGN

The Noise level for the worst possible SNR is determined, as can be observed in figure 5.12 the constellation points are still clearly separated, due to the signal recovery blocks. The next step is to introduce a frequency off-set. This slider moves by 0.02 times the sample rate which in this flow graph is set 50kHz, resulting in the convenient shift of 1 kHz per slider tick. Using a combination of added noise and a frequency shift of 2 kHz it is observed in figure 5.13 the signal is no longer distinguishable, and the frequency is shifted 2 kHz to the right. The same is observed if the slider is put to -0.04 corresponding to a shift of -2kHz.

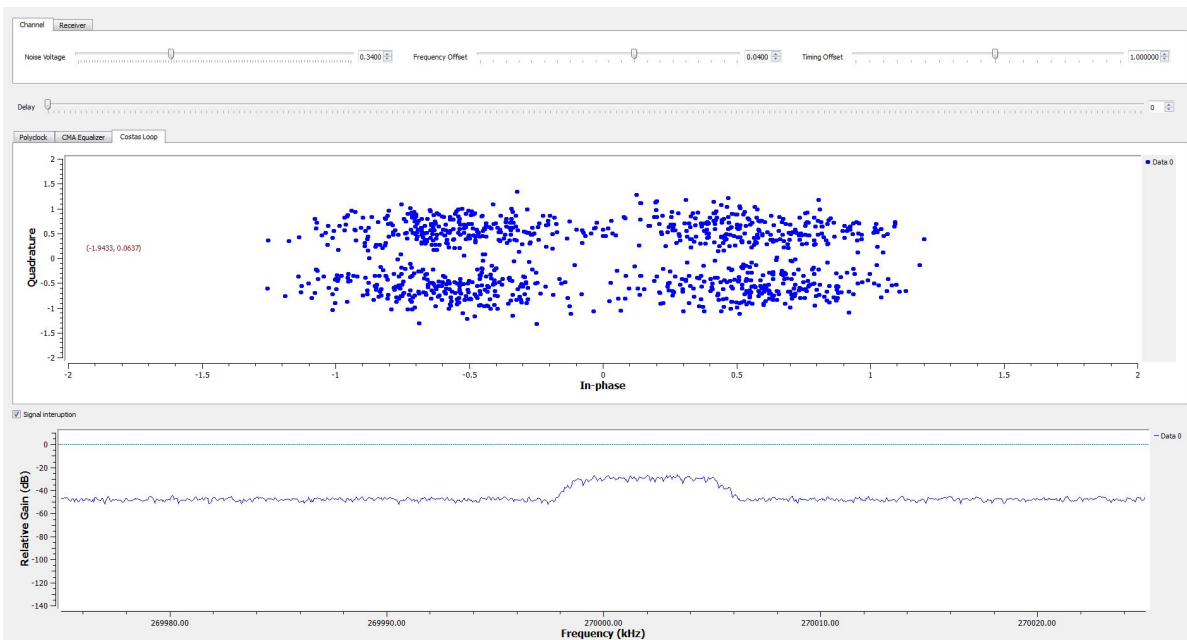
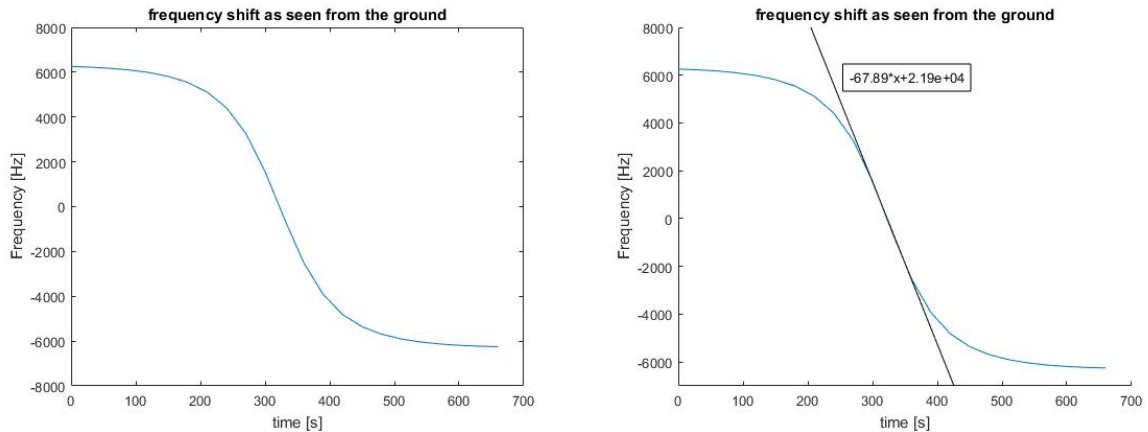

Figure 5.13: experiment AWGN and Frequency off-set

The Doppler shift causes a problem for the costas loop since it is larger than +/- 2 kHz. The expected Doppler shift can be calculated using the equations presented in [1]. In figure 5.14a the Doppler shift of a real passage

of the XW-2C satellite is presented. The slant range is calculated using the SGP4 model, the carrier frequency (f_0) is 270 MHz. The maximum frequency change occurs at the lower elevation either early or late in the satellite pass. Furthermore it can be observed that in the middle of the pass the curve is very steep. Since the Costas loop is not able to compensate for this effect a Doppler correction needs to be applied. This can be done by multiplying our signal with a wave which has a mirror frequency with respect to the shift. If the shift is 7kHz the signal is multiplied by a wave with a frequency of -7kHz. The only goal is to stay within the +/-1kHz correction limits of the Costas loop.



(a) Doppler shift calculated using TLE data of the XW-2C satellite (b) Approximation of the update rate on the Doppler correction

Figure 5.14: Doppler shift and correction rate.

In figure 5.14b a trend line is added to the Doppler shift plot, the reason this line is plotted is to calculate the update rate of the Doppler correction. As shown in figure 5.14b the trendline follows the steepest part of the curve and the polynomial formula is equal to $f(t) = -67.89 \cdot t + 2.19e + 04$. From this formula the update rate is determined to be 15 seconds. Unfortunately it is inconvenient to calculate the value using GNU radio, however, a test can be conducted to see if this frequency shifting actually works.

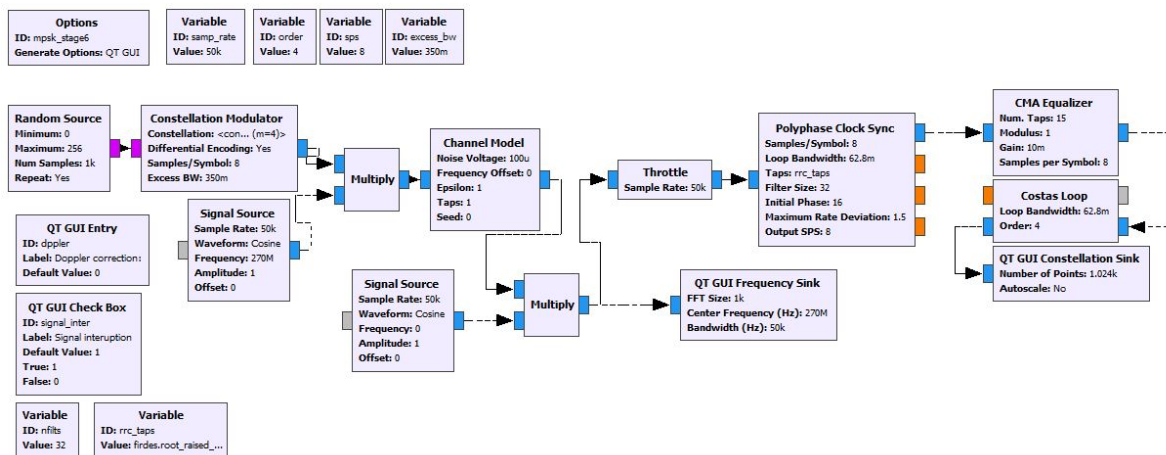

Figure 5.15: Channel model with Doppler correction

As can be observed in Figure 5.15 a signal source was added to the flow graph and multiplied with the signal just after the channel model. The frequency can be set manually using a GUI entry. The result can be observed in figure 5.16. Although the frequency offset is 0.06 (or 3 kHz) with a Doppler correction of -1kHz

the constellation plot shows four distinguishable points as one would expect for QPSK. Note for this test the Doppler correction was set manually, this can be automated with an external script and using the XMLRPC client block to feed values at a regular interval (15s) to the flowgraph. GNU radio will perform the interpolation and provide every sample with the needed frequency correction. During the Doppler correction experiment AWGN was added to the signal, however the time offset was kept zero.

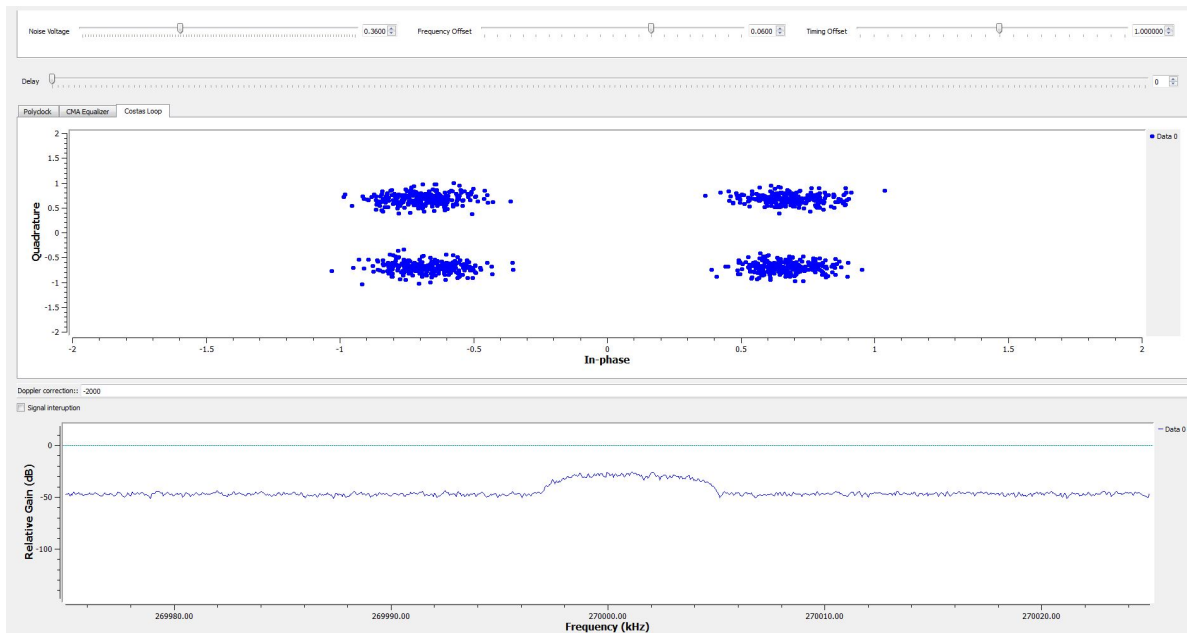

Figure 5.16: Frequency correction with Costas loop and manual Doppler correction

5.3.2. Information decoding

The easiest way to check if you can encode and decode blocks of data is by using the packet encoder and packet decoder block in GNU radio. The flow-graph that is used for this test can be seen in 5.17 from left to right, first a file is loaded figure 5.18 (a), this file is then chopped in packages of 200 bytes, a header (2x the length), preamble and an access code is added in order to recognise the start and length of a block. The longer the packages the longer the preamble and access code. In this test the preamble was set to the default value of the GNU radio block. The access code contains a random sequence of 1's and zero's, this sequence is repeated at the packet decoder. The bits per symbol in the packet encoder determine the modulation scheme (there is no modulation/transition to I&Q in this flow graph). As can be seen the data is reconstructed in figure 5.18 (b). The Packet Decoder expects a continuous stream of bits. Therefore the packed to unpacked block is used right after the packet encoder. The number of bits per chunk is set to 1 indicating it outputs one bit at a time. The differential encoder and decoder are placed to prove that differential encoding on bit level can be performed.

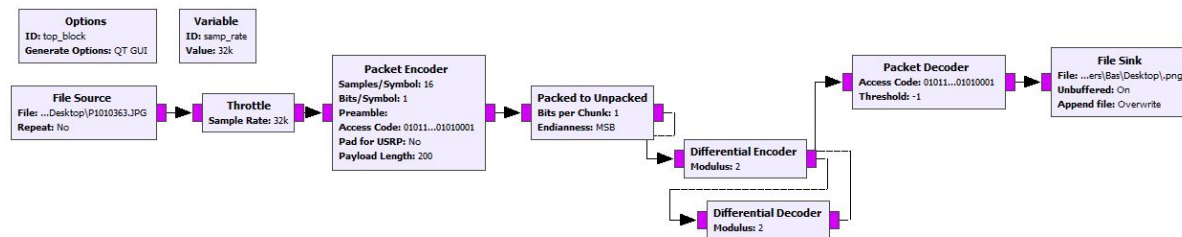

Figure 5.17: Packet encoder, decoder test



Figure 5.18: Left the data sent and right the data received (half way)

Depending on the modulation required the packet encoder needs to set at a certain Bit/symbol, the list can be found in table 5.7. Note that the packet encoder/decoder only work for GMSK, DPSK, QAM modulations. Therefore it is assumed that this particular block will not be used in the final design, but it provides a good reference on package handling with GNU Radio.

Table 5.7: Bit/symbol settings packet encoder

Modulation	Bits/Symbol
dBPSK	1
dQPSK	2
d8-PSK	3

For the Packet decoder block to work properly the bit stream needs to be a continues bit stream. However when using these blocks with actual hardware it proved very unreliable, Therefore it was decided to move the actual data reconstruction outside GNU radio. The actual implementation is still to be determined.

6

Conclusion and Recommendations

6.1. Conclusion

Derived from a usecase the following mission statement was compiled:

To design a portable, low cost and easy to use terminal, able to perform up-downlink of a 5 Mbyte file to a LEO orbiting satellite

The usecase and mission statement lead to system requirements, which formed the baseline of the design. The design was divided in two main parts the hardware design and the software design. By using volume, mass and power budgets the designs physical parameters where monitored and controlled. The interfaces where mapped in an N2 chart, resulting in a design that checks all but one requirement.

The hardware design consists of an Ettus b205 mini SDR, a NUC 7i7 processor board and a power amplifier. The terminal is complemented by a Harris AT001 antenna which is not part of the terminal but is part of the SOF's standard inventory. Furthermore additional parts where added like a GNSS sensor and a touchscreen. The system has a total mass of 3.6 kg and a volume of 2.38l. The EPS will guarantee at least 100 min Tx and Rx operations. By incorporating margins in the power, mass, volume and link budget a realistic preliminary design is made.

The software design would enable the user to work autonomously for 26 days due to the growing error in the orbit propagation model. After this time the terminal is unable to locate and contact the satellite. It allows easy operations by means of a touchscreen interface. The software design should also include the actual radio software, extensive tests where conducted and the results shown presented in this work. Furthermore a clear definition on the Doppler shift is presented and a proposed solution introduced.

In the mission statement it is mentioned that a total message size of 5 Mbyte should be transferred. After simulation and testing it can be concluded that the actual data transmission depends on the satellite architecture and could vary between the 2.87 Mbyte and 1.44 Mbyte. Applying for more bandwidth could solve this issue, but due to the limited availability of bandwidth in the frequency spectrum this request is unlikely to be honoured. A more feasible solution would be to investigate in alternative communication protocols, like go-back N ARQ or selective repeat ARQ.

Conducting tests and performing simulations it can be concluded that it is possible to design and manufacture a military terminal for store and forward using a CubeSat. However transferring 5Mbyte in a 25 KHz band in 10 minutes is, according to the results presented in this thesis, under the current assumptions not possible. Note some assumptions should be reconsidered in a later stage in the BRIK-II project, when there is a clear detailed payload design. The actual data volume can only be determined once the BRIK-II is commissioned

and in orbit.

In conclusion: this project helped in realising the next step for the RNLAf's nationally owned Store and Forward system. It provides a good baseline design and a general direction in which to look for software solutions regarding problems like the Doppler frequency shift. Furthermore it gives insight in the expected capabilities of the S&F within the mission constraints. Although there is still work to be done, a good foundation is provided in this thesis.

6.2. Recommendations

In this section a number of recommendations are presented, both on the design strategy and towards future terminal development. Until the satellite is in orbit a lot of details can be further investigated. Especially towards the software design, a lot of time and effort is required.

Although described in the S&F usecase the Fire and Forget mode has been discussed in this work. In future developments this mode should be exploited. Questions like how to do error control and how to make initial contact should be answered.

It is assumed the terminal shall use the same antenna for up- and downlink although no research was conducted towards the coupling between the Rx and Tx channels. This can add significant latency time when using the ARQ error control, therefore lowering the total data volume. A notch or band-stop filter could offer a possible solution, this should be further investigated.

In order to relax the power peaks originating from the amplitude behaviour of QPSK and 8-PSK, an additional investigation could be performed towards OQPSK or $\pi/4$ -PSK. A good overview is presented by ESA in the CCSDS recommendation for 'bandwidth efficient modulation'.

There are coding techniques which lower the BER requirement like Turbo-coding and Trellis-coding. When such coding is applied modulation techniques can be used at lower SNR. This means that using the same hardware a more complex modulation technique could be used. However there are also downsides to using these kind of techniques which will have impact on the data volume.

Other practical experiments should be conducted like temporarily loss of signal and disruption due to obstacles in the operating terrain. Whenever the signal is interrupted will the terminal be able to reestablish contact and still be able to transfer the entire message. Small non conclusive testing has been done but this should be further investigated.

Detecting and predicting the satellite pass, duration and first position on the horizon is done by the SPG4 model. It should be further investigated how this model performs during a Solar active period. There is also a timing problem which should be researched, this problem occurs when initial contact needs to be made, on an old TLE based satellite location. The user could be too late or too early and miss the satellite completely.

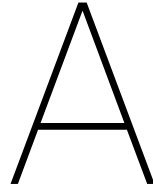

Appendix - I

This appendix contains the weight tables used in the radio trade off.

Table A.1: Trade criteria and importance

A	B	more important	intensity
channel	power	A	5
channel	temp	A	9
channel	sample	A	3
channel	volume	A	9
power	temp	A	5
power	sample	B	3
power	volume	A	5
temp	sample	B	7
temp	volume	A	3
sample	volume	A	7

In table A.1 five criteria can be seen the channel or tuning frequency, the output power the operating temperature, the maximum sample rate and the radio volume. Each criteria is compared to one another and a score is assigned to the importance.

Table A.2: Weight matrix

	Channel	Power	Temp	Sample	volume
channel	1	5	9	3	9
Power	0.2	1	5	0.333333	5
temp	0.111111	0.2	1	0.142857	3
sample	0.333333	3	7	1	7
volume	0.111111	0.2	0.333333	0.142857	1

In table A.2 the criteria of table A.1 are presented in a matrix. This matrix can later be used to calculate the results.

Table A.3: Tuning frequency score per option

Channel					
option	1	2	3	4	5
1	1.00	1.00	1.00	1.00	5.00
2	1.00	1.00	1.00	1.00	5.00
3	1.00	1.00	1.00	1.00	5.00
4	1.00	1.00	1.00	1.00	5.00
5	0.20	0.20	0.20	0.20	1.00

Table A.4: Output Power score per option

Power					
option	1	2	3	4	5
1	1.00	0.14	0.14	0.33	0.20
2	7.00	1.00	1.00	7.00	3.00
3	7.00	1.00	1.00	3.00	5.00
4	3.00	0.14	0.33	1.00	0.50
5	5.00	0.33	0.20	2.00	1.00

Table A.5: Operating temperature score per option

Temperature					
option	1	2	3	4	5
1	1.00	0.14	0.11	0.20	0.11
2	7.00	1.00	0.33	5.00	0.33
3	9.00	3.00	1.00	7.00	1.00
4	5.00	0.20	0.14	1.00	0.14
5	9.00	3.00	1.00	7.00	1.00

Table A.6: Sample rate score per option

Sample					
option	1	2	3	4	5
1	1.00	0.20	0.20	1.00	0.33
2	5.00	1.00	2.00	5.00	3.00
3	5.00	0.50	1.00	5.00	3.00
4	1.00	0.20	0.20	1.00	0.33
5	3.00	0.33	0.33	3.00	1.00

Table A.7: Occupied volume per option

Volume					
option	1	2	3	4	5
1	1.00	0.20	0.14	0.20	3.00
2	5.00	1.00	0.20	1.00	7.00
3	7.00	5.00	1.00	5.00	9.00
4	5.00	1.00	0.20	1.00	7.00
5	0.33	0.14	0.11	0.14	1.00

B

Appendix - II

In this appendix GRC flow-graphs are presented that were used to visualise the effect of different roll off factors, implementation loss and inter symbol interference.

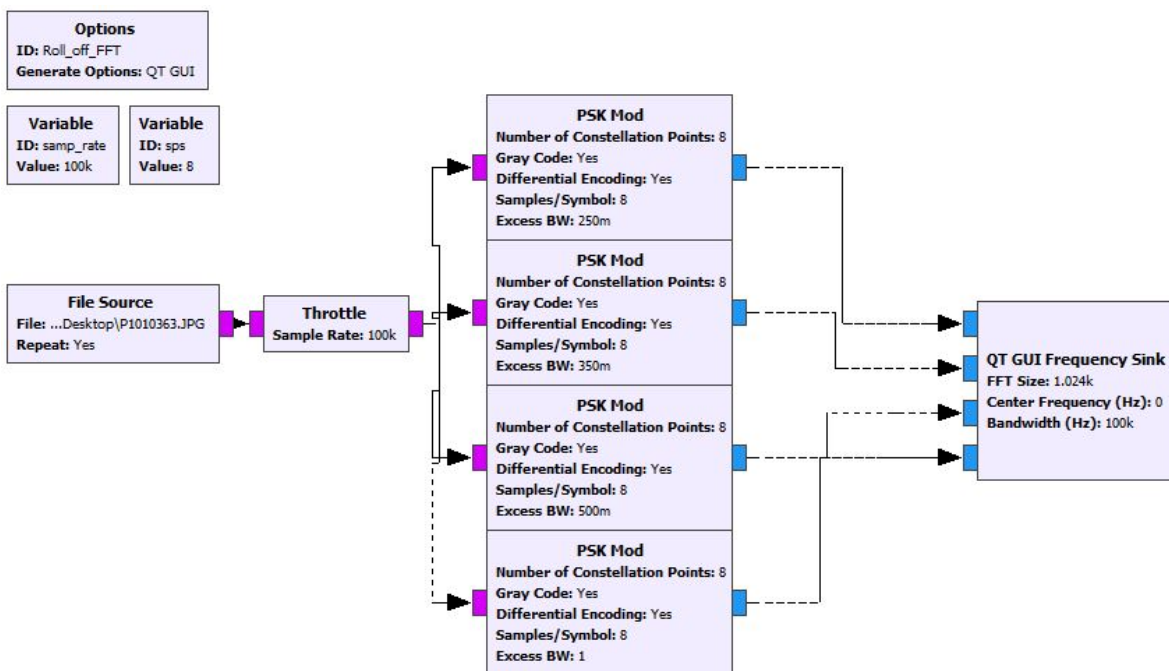

Figure B.1: GRC flowgraph Roll off simulation frequency domain

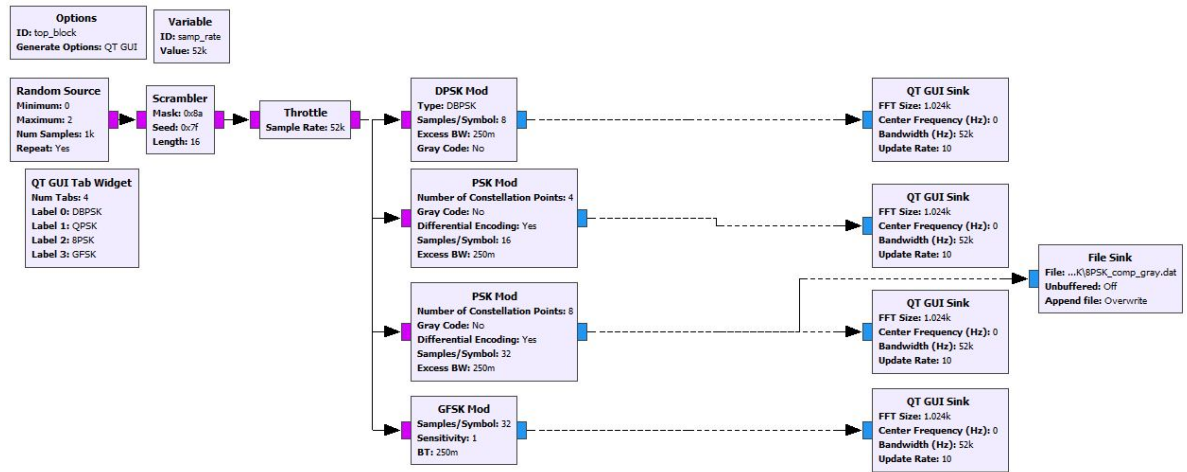

Figure B.2: GRC flowgraph Roll off simulation time domain

C

Appendix - III

This appendix contains photos of the measurement setup of both the Radio tests and the antenna measurements in the anechoic chamber.

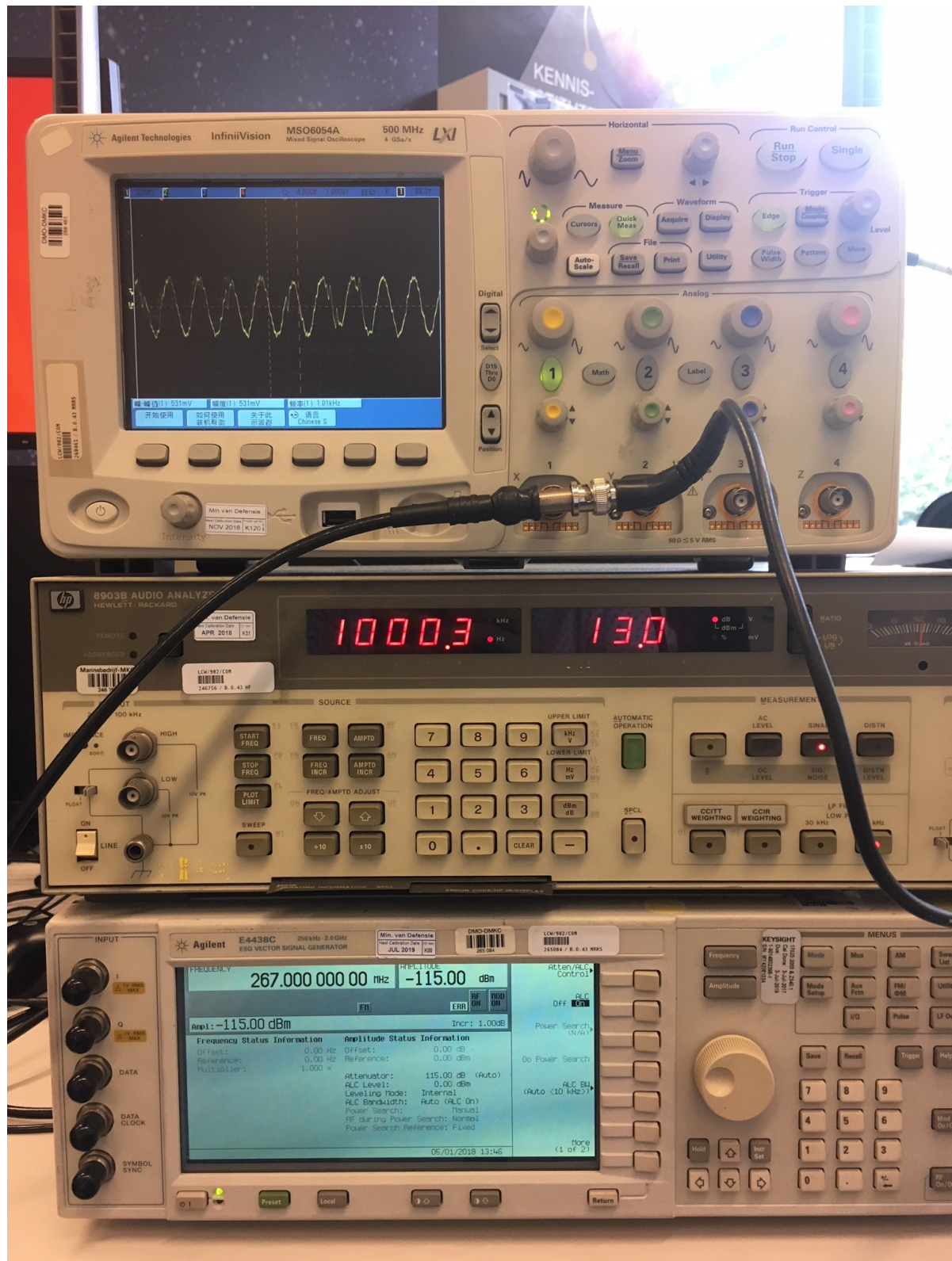

Figure C.1: Measurement setup for characterising the Ettus B205-mini



Figure C.2: Measurement Setup in configuration 3 (reflector and one set of directors)



Figure C.3: Monopole measurement to determine the gain of the radiator

D

Appendix - IV

This appendix contains the frequency supportability forms, which will be filled to the ITU.

**ANNEX A TO CHAPTER ERROR! REFERENCE SOURCE NOT
FOUND.:
FREQUENCY SUPPORTABILITY FORMS**

The NATO FMSC forms for FS request is provided on following pages as FS Forms 1, S Forms 2, FS Forms 3 and FS Forms 4 including instructions. The forms comprise entries which are intended to cater for a wide variety of stations. Additionally, national forms may be required by a number of host nations.

Those personnel indicated under paragraph **Error! Reference source not found.**, in close co-operation with the originator, are obliged to fill in these forms appropriately in order to provide as much information as required by any frequency authority allowing thorough assessments of the impact to the host nation and, finally, comprehensive handling of complicated requests.

NOTE: Up through the end of 2003 the only FS request format to be used is the forms reproduced at annex A to this chapter. These forms are reproduced from the DD Form 1494. Beginning in 2004 and when all Nations are capable of exchanging data in SMADEF (which is planned for implementation in ARCADE and a number of National tools), SMADEF will become the sole format for FS request and comments.

SMADEF will allow automatic recording of all FS requests and answers in the MRFL central database, which will be distributed to the Nations and Commands together with the assignment and allotment data. In the interim period, both formats will be accepted.

This annex will be removed from this document at the end of the interim period.

**TRANSMITTER EQUIPMENT CHARACTERISTICS
CARACTERISTIQUES DU MATERIEL EMETTEUR**

PAGE

1. Nameplate, Manufacturer's Model No. - Désignation, modèle du fabricant: Remote Ground Station Transceiver For UHF/S&F Uplink	2. Manufacturer's Name - Nom du fabricant: 9825QN
3. Transmitter Installation - Installation des émetteurs: Remote Ground station antenna carried by ground forces	4. Transmitter Type - Type d'émetteur: SDR
5. Tuning Range - Gamme d'accord: Uplink 312-322MHz	6. Method of Tuning - Méthode d'accord:
7. RF Channeling Capability - Répartition de voies RF:	8. Emission Designator(s) - Identificateur(s) d'émission:
9. Frequency Tolerance - Tolérance de fréquence:	
10. Filter employed - Filtre utilisé: Yes - Oui <input type="checkbox"/> No - Non <input type="checkbox"/>	12. Emission Bandwidth - Largeur de bande de l'émission: Calculated <input type="checkbox"/> Measured <input type="checkbox"/> Largueur de bande de l'émission: Calculée <input type="checkbox"/> Mesurée <input type="checkbox"/>
11. Spread Spectrum - Spectre étalé: Yes - Oui <input type="checkbox"/> No - Non <input type="checkbox"/>	(a) 3 dB (b) 20dB (c) 40dB (d) 60dB (e) OCCBW Larg. de bande occupée
13. Maximum Bit Rate - Taux bitaire maximal: 20500 bit/s BPSK, 41000 QPSK, 56750 bit/s 8-PSK	15. Maximum modulation frequency - Fréquence de modulation et de codage:
14. Modulation Technique and Coding - Techniques de modulation et de codage: BPSK, QPSK, 8-PSK. (AES256)	17. Deviation Ratio - Rapport de déviation:
16. Description - Présentation: Yes - Oui <input type="checkbox"/> No - Non <input type="checkbox"/>	19. Power - Puissance: (a) Mean - Moyenne _____ (b) PEP - En crête _____
18. Pulse Characteristics - Caractéristiques de l'émission: (a) Rate - Fréq. de répétition _____ (b) Width - Durée _____ (c) Rise Time - Temps de montée _____ (d) Fall Time - Temps de descente _____ (e) Comp Ratio - Rapport de comp. _____ Larg. de bande occupée	20. Output Device - Dispositif de sortie:
21. Harmonic Level - Niveau des harmoniques: (a) 2nd - 2e _____ (b) 3rd - 3e _____ (c) Other - Autres _____	22. Spurious Level - Niveau des parasites non désirés:
24. Remarks - Remarques: The remote radio station will be deployed all over the world. Since it is capable of predicting a satellite pass it will only operate in short time windows, these windows are approximately 10 min per operation and 2 or 3 operations per week whenever deployed.	

CLASSIFICATION Unclassified

**TRANSMITTER EQUIPMENT CHARACTERISTICS
CARACTERISTIQUES DU MATERIEL EMETTEUR**

PAGE

1. Nameplate, Manufacturer's Model No. - Désignation, modèle, modèle du fabricant: <i>Remote Ground Station Transceiver For UHF S&F Downlink</i>	2. Manufacturer's Name - Nom du fabricant: 982SQN
3. Transmitter Installation - Installation de l'émission: <i>Remote Ground station antenna carried by ground forces</i>	4. Transmitter Type - Type d'émission: SDR
5. Tuning Range - Gamme de accord: <i>Downlink 267-273MHz</i>	6. Method of Tuning - Méthode d'accord
7. RF Channeling Capability - Répartition de voies RF:	8. Emission Designator(s) - Identificateur(s) d'émission:
9. Frequency Tolerance - Tolérance de fréquence:	12. Emission Bandwidth - Largeur de bande de l'émission: Calculated <input type="checkbox"/> Measured <input type="checkbox"/> Calculée <input type="checkbox"/> Mesurée <input type="checkbox"/>
10. Filter employed - Filtre utilisé: Yes - Oui <input type="checkbox"/> No - Non <input type="checkbox"/>	(a) -3 dB
11. Spread Spectrum - Spectre étalé: Yes - Oui <input type="checkbox"/> No - Non <input checked="" type="checkbox"/>	(b) -20 dB
13. Maximum Bit Rate - Débit binaire maximal: 20500 bit/s BPSK, 41000 QPSK, 56750 bit/s 8-PSK	(c) -40 dB
14. Modulation Technique and Coding - Technique de modulation et de codage: BPSK, QPSK, 8-PSK. (AES256)	(d) -60 dB
16. Pre-emphasis - Préaccentuation: Yes - Oui <input type="checkbox"/> No - Non <input checked="" type="checkbox"/>	(e) OCEBW Largeur de bande occupée
18. Pulse Characteristics - Caractéristiques de l'émission:	15. Maximum modulation frequency - Fréquence de modulation et de codage:
(a) Rise - Temps de montée _____ (b) Width - Durée _____ (c) Rise Time - Temps de montée _____ (d) Fall Time - Temps de descente _____ (e) Comp Ratio - Rapport de comp. _____ Largeur de bande occupée	17. Deviation Ratio - Rapport de déviation: 19. Power - Puissance: (a) Mean - Moyenne _____ (b) PEP - En crête _____
21. Harmonic Level - Niveau des harmoniques:	20. Output Device - Dispositif de sortie:
(a) 2nd - 2e _____ (b) 3rd - 3e _____ (c) Other - Autre _____	22. Spurious Level - Niveau des parasites non essentiels:
24. Remarks - Remarques: The remote radio station will be deployed all over the world. Since it is capable of predicting a satellite pass it will only operate in short time windows, these windows are approximately 10 min per operation and 2 or 3 operations per week whenever deployed.	
CLASSIFICATION Unclassified	

CLASSIFICATION

ANTENNA EQUIPMENT CHARACTERISTICS
CARACTERISTIQUES DU MATERIEL D'ANTENNE

PAGE

1. Transmitting <i>Émission</i>		<input type="checkbox"/>	Receiving <i>Réception</i>		<input checked="" type="checkbox"/>	Transmitting and Receiving <i>Émission et Réception</i>		<input type="checkbox"/>	
2. Manufacturer's Model No. - <i>Désignation du modèle du fabricant</i> Harris RF-3080-A1001			3. Manufacturer's Name - <i>Nom du fabricant</i> Harris						
4. Frequency Range - <i>Gamme de fréquences</i> 240 - 318 MHz			5. Type Crossed yagi						
6. Polarization - <i>Polarisation</i> Circular (RHCP)			7. Scan Characteristics - <i>Caractéristiques de balayage</i> Antenna on EL/AZ pedestal						
8. Gain			(a) Type <i>feed/pilot</i> (b) Vertical Scan <i>Balayage vertical</i> (1) Max Elev <i>Amplitude max</i> 90 degrees (2) Min Elev <i>Amplitude min</i> 10 degrees (3) Scan Rate <i>Vitesse de balayage</i>						
(a) Main Beam <i>Faisceau principal</i> 9 dB (b) 1st Major Side Lobe <i>1er lobé latéral important</i> -3dB			(c) Horizontal Scan <i>Balayage horizontal</i> (1) Sector Sweep <i>Secteur balayé</i> 0 - 360 degrees (2) Scan Rate <i>Vitesse de balayage</i> (d) Sector Blanking <i>Egagement de secteur</i>					Yes <input type="checkbox"/> No <input type="checkbox"/> Oui Non	
9. Beamwidth - <i>Largeur d'ouverture</i>									
(a) Horizontal (b) Vertical									
21. Remarks - <i>Remarques</i> This antenna is used by special teams to monitor areas all over the world. The antenna will be pointed to the satellite by hand, or by a real-time system depending on the mission. The same antenna will be used for up and downlink.									

Bibliography

- [1] I. Ali, N. Al-Dhahir, and J. E. Hershey. Doppler characterization for leo satellites. *IEEE Transactions on Communications*, 46(3):309–313, Mar 1998. ISSN 0090-6778. doi: 10.1109/26.662636.
- [2] Harris assured communications. Specifications for the rf-3080-at001. https://www.harris.com/sites/default/files/rf-3080-at001_web_tcm26-9090.pdf. accessed on 05/04/2018.
- [3] Constantine A. Balanis. *Antenna Theory*, volume 4th Revised edition. John Wiley and Sons Inc, 2016. ISBN 9781118642061.
- [4] William T. Brandon. A data courier satellite system cconcept. *International Journal of satellite commnications*, 12:569–578, 1994.
- [5] G. J. Burke and A. J. Poggio. Nec-2 manual, part iii: User’s guide. <http://www.nec2.org/other/nec2prt3.pdf>. accessed on 12-09-2017.
- [6] L. J. Chu. Physical limitations of omni-directional antennas. *Journal of Applied Physics*, 19(12):1163–1175, 1948. doi: 10.1063/1.1715038. URL <http://dx.doi.org/10.1063/1.1715038>.
- [7] Alexander A Chukhlantsev, Anatolij M Shutko, and Sergei P Golovachev. Attenuation of electromagnetic waves by vegetation canopies in the 100-10000 mhz frequency band. *Journal of Radio Electronics*, 2, 2003.
- [8] Leon W Couch. *Digital and analogue communication systems*. Pearson Education Limited, international edition edition, 2013.
- [9] D. Godard. Self-recovering equalization and carrier tracking in two-dimensional data communication systems. *IEEE Transactions on Communications*, 28(11):1867–1875, Nov 1980. ISSN 0090-6778. doi: 10.1109/TCOM.1980.1094608.
- [10] Roger F Harrington. *Field Computation by Moment Methods*. Wiley-IEEE Press, 1993. ISBN 0780310144.
- [11] L. T. Jones. When 12-db sinad is not 12-db sinad [land mobile fm receivers]. In *6th IEEE Conference Record., Instrumentation and Measurement Technology Conference*, pages 505–507, Apr 1989. doi: 10.1109/IMTC.1989.36911.
- [12] Wenschel Lan, Jonathan Brown, Armen Toorian, Roland Coelbo, Lori Brooks, Jordi Puig-Suari, and Robert Twiggs. Cubesat development in education and into industry. In *Space 2006*, page 7296. 2006.
- [13] W. Larson, D. Kirkpatrick, J. Sellers, L. Thomas, and D. Verma. *LSC CPS1 () : LSC CPS1 (USAF) Applied Systems Engineering - Space*. McGraw-Hill Education, 2009. ISBN 9780073408866.
- [14] Mathworks. Signal processing toolbox. <https://nl.mathworks.com/products/signal.html>, 2017. accessed on 05-04-2017.
- [15] Eytan Modiano. An adaptive algorithm for optimizing the packet size used in wireless arq protocols. *Wireless Networks*, 5(4):279–286, Jul 1999. ISSN 1572-8196. doi: 10.1023/A:1019111430288. URL <https://doi.org/10.1023/A:1019111430288>.
- [16] NATO NSA. Climate conditions aectp 230, . 2006.
- [17] NATO NSA. Climatic environmental test aectp 300, . 2006.
- [18] NATO NSA. Mechanocal environmental test aectp 400, . 2006.
- [19] NATO NSA. Electrical electromagnetic environmental conditions aectp 500, . 2006.

-
- [20] GNU Radio. Gnu radio. <http://gnuradio.org/>, 2017. accessed on 05-04-2017.
- [21] GNU Radio. Gnu radio. https://gnuradio.org/doc/doxygen/classgr_1_1digital_1_1pfb__clock__sync__ccf.html#details, 2018. accessed on 01-03-2018.
- [22] SKB Cases UK. Waterproof cases. <http://www.skbcases.co.uk/mil-std-waterproof.html>. accessed on 04-12-2017.
- [23] David Vallado and Paul Crawford. Sgp4 orbit determination. In *AIAA/AAS Astrodynamics Specialist Conference and Exhibit*, page 6770, 2008.
- [24] David A Vallado, Paul Crawford, Richard Hujsak, and TS Kelso. Revisiting spacetrack report# 3. *AIAA*, 6753:2006, 2006.