

The Universal Fixator

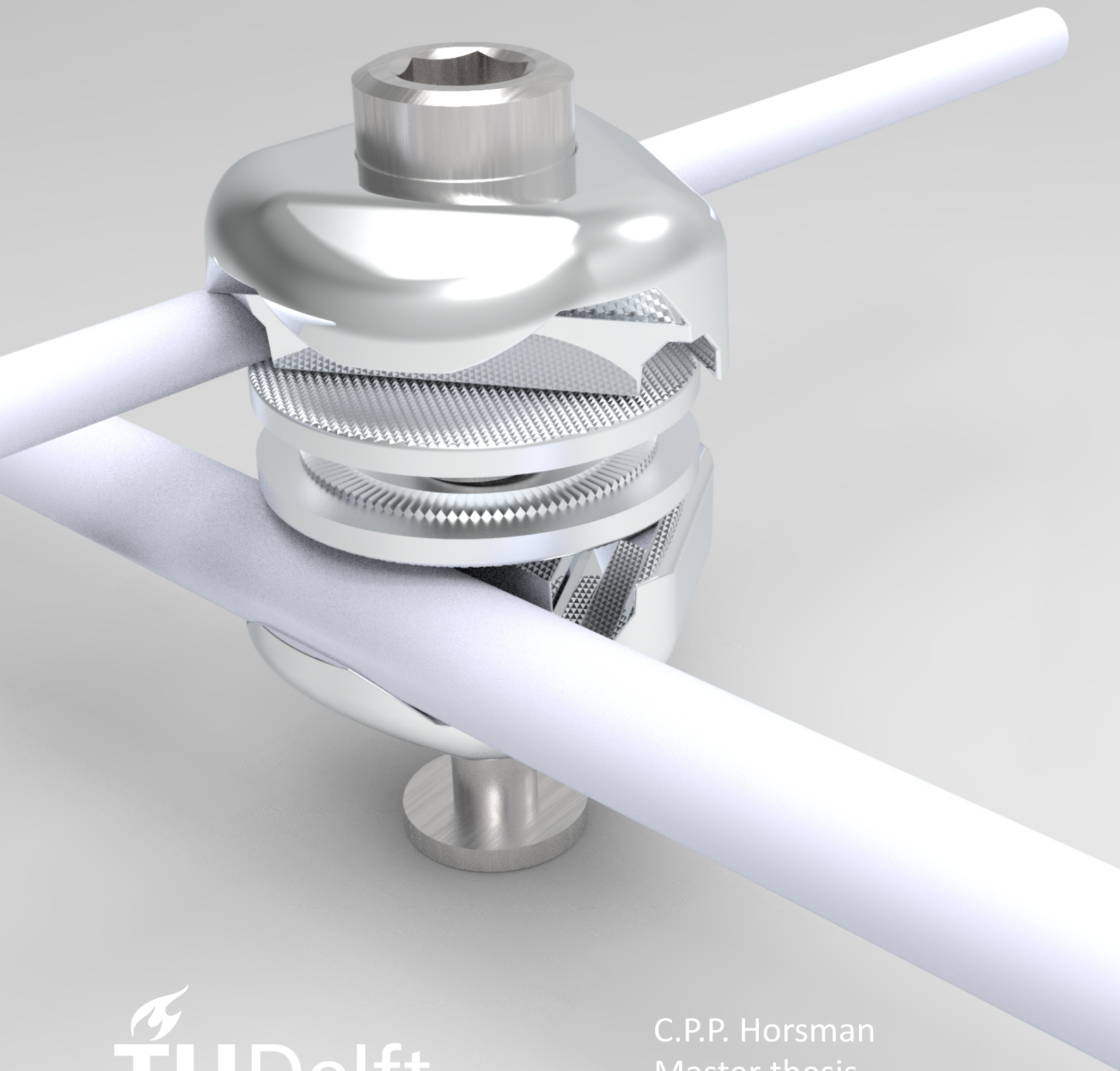

The development of a universal fixator for application in low-and middle income countries

In partial fulfilment of the requirements for the degree

Master of Science

Biomedical Engineering

to be defended publicly on Tuesday December 18, 2020 at 11:00 AM.

Student number: 4952804
Project duration: February 1, 2020 – December 18, 2020
Thesis committee: Prof. Dr. Ir. J. Dankelman, TU Delft, supervisor
Dr. Ir. T. Horeman, TU Delft
Dr. Ir. N. Tumer, TU Delft
P. Bongers, AUMC/GSA

This thesis is confidential and cannot be made public until December 18, 2022.

An electronic version of this thesis is available at
<http://repository.tudelft.nl/>.



Abstract

In the worlds poorest regions there exists an urgent need for surgical care. Open fractures, one of the Bellwether procedures, are treated in only 42% of the health facilities in low- and middle income countries. Worldwide, external fixation is one of the most important treatment methods for open fractures, providing immobilization to the fracture while retaining soft tissue integrity. In LMICs however, is the treatment of open fractures with an external fixator not self-evident. Due to a lack of equipment and incomplete donations, a clear need is indicated for application of a standardized low-cost external fixator system for LMICs.

The goal of this thesis is to develop a universal fixator clamp for application in low - and middle income countries, providing fixation to both lower- as upper extremity open fractures. In collaboration with Global Surgery Amsterdam and the Amsterdam University Medical Centre, the design of a predecessor external fixator clamp is improved. The design of this clamp consists of three slots: 4mm, 5mm, and 8mm. As a consequence, this reduces the number of components needed to perform external fixation. Included factors in this iterative design process are the identification of needs, serving as input for the prototype development of the universal clamp. Based on the defined needs the product requirements are defined, giving prioritization to cost-effectiveness. These requirements served as input for the next phase of the design process. The conceptualization of the refined universal clamp is guided by three subproblems: stability enhancement, weight reduction, and increasing functionality. A material analysis demonstrates aluminium 6061 is the most suitable for this application. Next, the theoretical mechanical behavior of the developed clamp concept is analyzed using two use cases. The final clamp concept is manufactured and compared in six mechanical tests with a state-of-the-art external fixator clamp, the Hoffmann 3, to evaluate the performance. Slippage and rotational tests are performed at three different tightening torques for all three diameters.

The universal clamp performs significantly less on all six mechanical tests and as a consequence provides less stability to open fractures in comparison with the Hoffmann 3 clamp. Therefore, further development of the universal fixator is necessary to be successfully adopted as a Lifebox-idea to improve open and neglected fracture treatment in LMICs.

Preface

Injuries are a leading cause of mortality and disability and are considered as a global public health problem. To improve the quality of surgery and anaesthesia services in low- and middle income countries (LMICs), the Lancet commission on Global Surgery was launched. They recommended six key metrics to improve national surgical plans towards 2030. One of these key metrics is access to a facility where the three Bellwether procedures are provided. Open fractures, one of the Bellwether procedures, are treated in only 42% of the cases in LMICs. The incidence of open fractures is predicted to increase in the future, as a result of growing mobility and urbanisation. Finding a cost-effective treatment for open fractures would therefore be a huge breakthrough in improving the quality of life in LMICs.

External fixation is a promising technique to treat severe open fractures in LMICs, because it provides early stabilization while retaining soft tissue integrity. This thesis describes the project that was conducted with the aim of developing an external fixator to be implemented in every hospital in LMICs. With the goal to perform the necessary interventions, with the minimally needed components, and materials that can also be developed in own countries. This study assesses the needs regarding external fixation treatment expressed by surgeons in LMICs, and translates these requirements into an external fixator prototype clamp intended for application LMICs.

This study was performed in collaboration with Global Surgery Amsterdam, the Amsterdam University Medical Centre (drs. M. Botman, P. Bongers), and the Technical University Delft (prof. dr. J. Dankelman). I would like to thank all these collaborators without whom this thesis would not have been possible.

Especially, I would like to thank prof. dr. J. Dankelman for being my excellent mentor who always took time out of her very busy schedule to guide and discuss obstacles with me. Her knowledge and experience in medical device development fed my interests and motivated me to strive for the best possible outcome. Also, I want to praise dr. T. Horeman for his relevant discussions and engineering recommendations regarding the clamp concept development.

I would like to thank drs. M. Botman for being my excellent mentor in the hospital throughout the thesis project. His enthusiasm and personal goal to improve surgery in low-resource settings truly fuelled my drive to achieve the best results possible. Connecting me to medical experts contributed immensely to the development of the prototype. In addition, I would like to thank P. Bongers for his daily guidance and critical view on the product development.

Also, I want to thank Global Surgery Amsterdam for their inspiring story and goal to provide universal access to safe and affordable surgical care. Hopefully, with the development of this universal clamp prototype I can make a small contribution to this motivating goal of this foundation.

Last but not least I would like to thank my family and friends, especially my dad, for their support and interest in my research and providing me with useful contacts in the medical world.

I hope that you enjoy reading this thesis as much as I enjoyed working on it.

Christiaan Horsman
Delft, December 7, 2020

Contents

Glossary	ix
List of Figures	xi
1 Introduction	1
1.1 Background	1
1.2 Objectives.	2
2 Background	3
2.1 Classification of open fractures	3
2.2 Open fracture treatment with an external fixator	4
2.3 Operation procedure	5
2.4 Complications.	6
2.5 Weightbearing	7
3 Method	9
3.1 Project planning	10
3.2 Literature study & patent research.	10
3.3 Identification of needs in LMICs	10
3.4 Product requirements	10
3.5 Conceptualization	11
3.6 Material analysis	11
3.7 Theoretical analysis	11
3.8 Final clamp design	11
3.9 Prototype manufacturing	11
3.10 Mechanical testing	12
4 Identification of needs in LMICs	13
4.1 Lifebox case	13
4.2 Collaboration with TU Delft and GSA	14
4.3 Evaluation of requirements.	16
5 Product requirements	17
5.1 General specifications	17
5.2 Design specifications.	18
6 Conceptualization	19
6.1 Stability enhancement	19
6.2 Introduction of spring compartment	20
6.3 Weight reduction	22
6.4 Increasing functionality.	22
6.5 Final clamp concept	24
7 Material Analysis	27
8 Theoretical Analysis	33
8.1 Finite Element Analysis	33
8.1.1 The interaction between screw and upper component	33
8.1.2 The effect of tibial weightbearing on the clamp concept	35
8.2 Bolt analysis	38

9 Final Clamp Design	41
10 Prototype manufacturing	43
10.1 Manufacturing methods	43
10.1.1 3D printing	43
10.1.2 CNC machining	45
10.2 Manufacturing of the prototype	46
11 Mechanical Testing	49
12 Discussion	59
12.1 Limitations	61
12.2 Recommendations for further development	61
13 Conclusion	63
Appendices	65
A Manual external fixation procedure	67
B Harris profile three-way-clamp	73
C Requirements weighing of the three-way-clamp	75
D Patent search fix ex systems	77
E Harris profile patent research	83
F Technical drawings	85
G Thread engagement calculation	89
H Matlab script slippage analysis	91
I Technical drawing testing fixture	95
Bibliography	97

Glossary

Additive manufacturing	The construction of a three-dimensional object from a CAD model or a digital 3D model.
Anaesthesia	Anesthesia or anaesthesia is a state of controlled, temporary loss of sensation or awareness that is induced for medical purposes.
Anteroposterior	Relating to or towards both front and back.
Biocompatibility	The capability of coexistence with living tissues or organisms without causing harm.
Callus	A new growth of osseous matter at the ends of a fractured bone.
Comminution	A fracture in which the bone is splintered or crushed into numerous pieces.
Contusion	An injury, as from a blow with a blunt instrument, in which the subsurface tissue is injured but the skin is not broken; bruise.
Distal	Situated away from the point of origin or attachment, as of a limb or bone.
Extracutaneous	Outside of the skin or cutis.
Fluoroscopy	The use or examination with an instrument used for observing the internal structure of an opaque object by means of X-rays.
Free flap procedure	A procedure in which tissue and its blood supply (artery and vein) are surgically removed from one part of the body and transferred to another area of the body for the purpose of reconstruction.
Iterative	The repetition of a process in order to generate an outcome.
Joint cavity	The unfilled articular space enclosed by the synovial membrane and articular cartilages.
Linear actuator	An actuator that creates motion in a straight line.
Malunion	Incomplete union or union in a faulty position after a fracture or wound.
Mortality	The state or condition of being subject to death.
Necrosis	Death of a circumscribed portion of animal or plant tissue.
Non-union	Permanent failure of healing following a broken bone unless intervention (such as surgery) is performed.
Obstetrics	The field of study concentrated on pregnancy, childbirth and the postpartum period.

Osteogenesis	Development and formation of bone.
Osteomyelitis	An infectious usually painful inflammatory disease of bone often of bacterial origin that may result in the death of bone tissue.
Periosteal stripping	The primary surgical technique for angular limb deformities of the lower radius and tibia.
Plastic deformation	A permanent deformation or change in shape of a solid body without fracture under the action of a sustained force.
Proximal	Situated nearer to the centre of the body or the point of attachment.
Septic arthritis	The invasion of a joint by an infectious agent resulting in joint inflammation.
Sterilization	The process of making something free from bacteria or other living microorganisms.
Trocar	A sharp-pointed surgical instrument fitted with a cannula and used especially to insert the cannula into a body cavity as a drainage outlet.
Weightbearing	The amount of weight a patient puts on an injured body part.

Acronyms

ASTM	American Society for Testing and Materials
AIDS	Acquired Immunodeficiency Syndrome
AUMC	Amsterdam University Medical Centre
BW	Body weight
CAD	Computer-aided design
CNC	Computer-numerical-control
EF	External fixator
FDA	Food and Drug Administration
FEA	Finite Element Method
GSA	Global Surgery Amsterdam
GRF	Ground reaction force
HIC	High- income country
HIV	Human immunodeficiency virus
ISO	International Standards Organization
LDMD	Laser direct metal deposition
LMIC	Low- and middle income country
OR	Operating room
PREN	pitting corrosion equivalent number
Psi	Pounds per square inch
SEBM	Selective electron beam melting
SLM	Selective laser melting
TU	Technical university
YM	Young's modulus

List of Figures

1.1	Different parts of different fixator systems used as a treatment method for an open fracture in LMICs.	2
1.2	Treatment of an open fracture in LMIC performed with 'not for patient use' components.	2
2.1	Gustilo and Anderson classification of open fractures [39]	3
2.2	Gustilo Grade III-C open fracture of the humerus. A) Clinical image of the humerus fracture. B) Early and initial management of the humerus fracture by temporary external fixation [38].	4
2.3	Placement of the pins of the external fixator in the proximal- and distal bone fragments.	5
2.4	Predrilling of both bone cortices when using self-tapping pins, with optional trocar support.	5
2.5	Indication of the penetration limit of the distal bone cortex.	5
2.6	Assembly of the external fixator frame by connecting the pins with clamps to the connecting bars.	6
2.7	Reduction of the fracture after connection of the two partial frames.	6
3.1	Flowchart describing the design process of the thesis project started in February 2020.	9
4.1	Pulse oximeter developed by Lifebox to enhance the safety of anaesthesia in LMICs	13
4.2	Depth utility prototype developed for LMICs, attached to fixator pin	15
4.3	Minimal box solution for the treatment of open fractures in LMICs	15
4.4	The three-way clamp prototype, the developed product in a first collaboration between the TU Delft and GSA.	15
6.1	First clamp concept; a) Isometric view, b) Top view, c) Bottom view	19
6.2	Second clamp concept; a) Isometric view, b) Top view, c) Bottom view	20
6.3	Third clamp concept; a) Isometric view, b) Top view, c) Bottom view	21
6.4	Fourth clamp concept; a) Isometric view, b) Top view, c) Bottom view	22
6.5	Fifth clamp concept, helical compression spring option; a) Isometric view, b) Top view, c) Bottom view	23
6.6	Sixth clamp concept, disc spring option; a) Isometric view, b) Top view, c) Bottom view	23
6.7	Final clamp concept; a) Isometric view, b) Top view, c) Bottom view	24
6.8	Final clamp concept in sterilization position, isometric view	25
7.1	Young's Modulus (10^6 psi) vs. Price (USD/lb) of the included materials ($n = 906$) in the EduPack analysis. Grey materials are excluded from the analysis as a result of the set limitations.	28
7.2	Young's Modulus (10^6 psi) vs. Price (USD/lb) of the included materials ($n = 17$) in the EduPack analysis. Grey materials are excluded from the analysis as a result of the set limitations.	28
7.3	Young's Modulus (10^6 psi) vs. Price (USD/lb) of the included materials ($n = 41$) in the EduPack analysis. Grey materials are excluded from the analysis as a result of the set limitations.	29
7.4	Young's Modulus (10^6 psi) vs. Density (lb/in^3) of the included materials ($n = 17$) in the EduPack analysis. Grey materials are excluded from the analysis as a result of the set limitations.	30
7.5	Young's Modulus (10^6 psi) divided by Density (lb/in^3) vs. Price (USD/lb) of the included materials ($n = 17$) in the EduPack analysis.	31

8.1	Top view of the simulated clamp concept. Overview of the fixtures and loads on the included components.	34
8.2	Bottom view of the simulated clamp concept. Overview of the fixtures and loads on the included components.	34
8.3	Overview of the displacement (mm) in the clamp as a result of the applied force on the simulated clamp concept. Top view.	35
8.4	Overview of the displacement (mm) in the clamp as a result of the applied force on the simulated clamp concept. Bottom view.	35
8.5	Overview of the Von Mises (N/m^2) in the clamp as a result of the applied force on the simulated clamp concept. Top view.	35
8.6	Overview of the Von Mises (N/m^2) in the clamp as a result of the applied force on the simulated clamp concept. Bottom view.	35
8.7	Top view of the fixtures and loads applied on the components of the simulated clamp concept during weightbearing.	36
8.8	Bottom view of the fixtures and loads applied on the components of the simulated clamp concept during weightbearing.	36
8.9	Overview of the displacement (mm) as a result of weightbearing on the simulated clamp concept. Top view.	37
8.10	Overview of the displacement (mm) as a result of weightbearing on the simulated clamp concept. Bottom view.	37
8.11	Overview of the Von Mises (N/m^2) as a result of weightbearing on the simulated clamp concept. Top view.	37
8.12	Overview of the Von Mises (N/m^2) as a result of weightbearing on the simulated clamp concept. Bottom view.	37
8.13	Overview of the displacement(mm) as a result of weightbearing on the simulated clamp concept. Focused on the area of maximum induced displacement at the upper component of the universal clamp concept.	38
8.14	Overview of the Von Mises (N/m^2) as a result of weightbearing on the simulated clamp concept. Focused on the area of maximum induced stress at the upper component of the universal clamp concept.	38
9.1	Rendering of the final external fixator clamp concept.	41
10.1	Schematic diagram of components involved in selective laser melting (SLM) process[35].	44
10.2	Schematic diagram of components involved in laser direct metal deposition (LDMD) process[72].	44
10.3	Schematic diagram of components involved in selective electron beam melting (SEBM) process[61].	45
10.4	Schematic drawing of CNC machine, describing the axis of the CNC spindle to perform a cut or other function [67].	46
10.5	The CNC turning lathe (Japan Fanuc) used by <i>Tosony B.V.</i> for manufacturing of the four external fixator clamp prototypes.	47
10.6	The five-axis CNC milling machine (Japan Fanuc) used by <i>Tosony B.V.</i> to manufacture four of the external fixator clamp prototypes.	47
10.7	On the left, the universal clamp prototype. On the right a tibial open fracture model treated with a hybrid external fixation, consisting of three universal clamps and three Hoffmann 3 clamps.	47

Introduction

1.1. Background

In the world poorest regions there exists an urgent need for surgical care. Without this care, easily treated illnesses become diseases with high mortality rates and extensive complications. Worldwide, two to five billion people have poor access to essential medical care [68]. For 28 – 32% of the global burden of disease, surgical care is needed [66]. According to the WHO, 5.8 million people die from injuries each year. This accounts for 10% of mortalities in the world, 32% more than the number of fatalities as a result of HIV/AIDS, malaria, and tuberculosis combined [76]. The incidence of injuries is a growing problem, given the fact that the three main causes of injuries, road traffic accidents, suicide, and homicide, are all predicted to rise in rank compared to other causes of death. This places these three leading causes of death globally from injuries among the top 20 leading causes of death in the world by 2030 [55]. With increasing industrialisation and urbanisation, injuries as a result of car accidents will constitute an increasing proportion of the global burden of disease, and consequently raises the need for trauma and emergency surgical services [54].

In low- and middle income countries (LMICs), nine out of ten people have no access to basic surgical care [42]. LMICs are countries with a global national income (GNI) per capita between \$1,036 and \$4,045, as defined by the World Bank [7]. Therefore, in 2014 the Lancet commission on Global Surgery was launched, with the primary goal to assess the crucial challenges and key opportunities in the development and delivery of quality surgical and anaesthesia services in LMICs. Six key metrics were recommended by the commission to improve national surgical plans and scale-up toward 2030. The measurement of access to surgery, timeliness, safety, and affordability could be performed with these metrics [74]. One of these key metrics is access to a facility where the three Bellwether procedures are provided: laparotomy, caesarean delivery, and treatment of open fractures. These procedures require the skills that span general and orthopaedic surgery, obstetrics, and anaesthesia [56]. Providing these Bellwether procedures should be an important goal of all primary care hospitals, as systematically facilitating these procedures suggests that functional surgical systems with a versatile service delivery are obtained.

Open fracture treatments, one of these Bellwether procedures, are commonly presented in the hospital and can be caused by a simple fall or a serious accident. The presence of an open fracture can lead to increased morbidity, as a result of a damaged protective skin and therefore the risk of infection is high [17]. Consequently, timely and correct treatment of patients suffering an open fracture is of utmost importance in order to achieve the best possible outcome. However, in first-level hospitals in LMICs only 42% of all open fractures are treated, which is supported by findings in country-specific studies [49].

The goals of treating open fractures are the prevention of infection, to provide the optimal conditions for bone healing, and the recovery of function [17]. Worldwide, one of the most important treatment methods for open fractures is external fixation. For severe open fractures early stabilization is required, which can be accomplished easily by external fixation. This treatment method provides immobilization

of the fracture while retaining soft tissue integrity. External fixation can be used as a provisional or definitive treatment method for open fractures, with the primary goals to maintain length, alignment, and rotation of the open fracture [33].

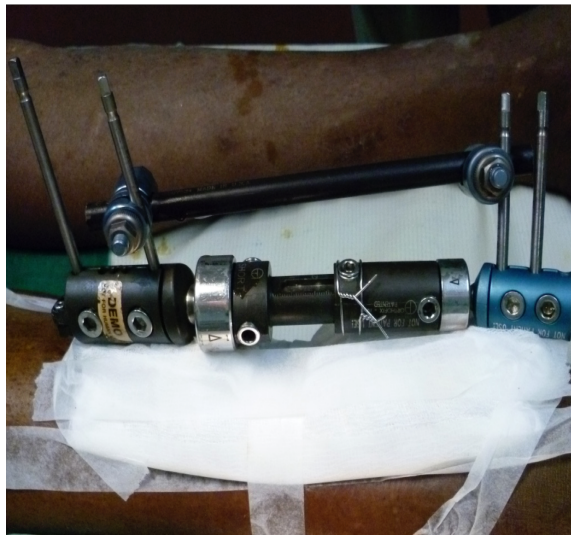

Figure 1.1: Different parts of different fixator systems used as a treatment method for an open fracture in LMICs.



Figure 1.2: Treatment of an open fracture in LMIC performed with 'not for patient use' components.

In LMICs is the treatment of open fractures with an external fixator not self-evident. Sometimes current external fixators used in LMICs are composed of different components of different external fixators, as shown in figure 1.1. In some cases, the components of the external fixators are manufactured for no patient use, displayed in figure 1.2. These systems might be exaggerated situations, but indicate the clear need for application of a standardized low-cost external fixator system for LMICs.

To date external fixator systems are often advanced systems, with a high functionality and versatility of open fractures to be treated. In LMICs, given the limited financial-, material-, and human resources, there is a great need to use cheap materials and simple technology to develop an external fixator [69][16]. Therefore, the goal of this master project is to develop a low-cost external fixator, a so-called 'Lifebox idea', to treat open fractures. To design an external fixator to be implemented in every hospital in LMICs to perform the necessary interventions, with the minimally needed components, and materials that can also be developed in own countries.

1.2. Objectives

The aim of this master thesis is to develop and improve the clamp design of the external fixator for application in LMICs. This thesis work includes the following:

- Identifying the needs in LMICs and requirements for the external fixator clamp.
- Providing solutions based on the design requirements, without risking the functionality of the working principle the technology is based on.
- Evaluation of the clamp design using FEA and mechanical analysis.
- Presenting an overall design solution for the medical device by means of 3D renderings and a prototype.

2

Background

2.1. Classification of open fractures

To provide the required treatment for patients suffering open fractures, the type of open fracture presented should be classified. The Gustillo classification, shown in figure 2.1, is generally accepted as the primary classification system for open fractures [39]. In this classification system three type of fractures are distinguished, divided based on the energy the injury [32]. Grade I, aligned on the left side of figure 2.1, are simple fractures with a disruptive skin, with limited contamination and good soft tissue coverage. In general as a result of a moderate trauma, Grade II injuries are characterized by a more complex fracture pattern, with more soft tissue contusion. High-energy trauma accidents are the causation of Grade III injuries. These type of fractures are characterized by comminution and contamination of the fracture, usually supplemented by extensive soft tissue injury associated with periosteal stripping. Within this Grade III classification, sub-classifications are used to distinguish between the likelihood of infection and complexity of the open fracture. The sub-classification III-A is given when the fracture can be adequately covered and has no vascular injury. Sub-classification III-B embodies the open fracture when it cannot be covered by a soft tissue envelope. In these type of open fractures a rotational or free flap procedure is implemented to achieve coverage of the fracture. When facing a vascular injury in the open fracture requiring operational repairing, the fracture is characterized as Grade III-C. This classification has a prognostic connotation, indicating the increase in chance of infection and complication when moving up in Grade [70]. Furthermore, the widespread implementation and adoption of this classification provides clinical usefulness and guides therapy when an open fracture is presented.

	I	II	III-A	III-B	III-C
Energy of mechanism	Low	Moderate	High	High	High
Wound size	<1 cm	>1 cm	Usually >10 cm	Usually >10 cm	Usually >10 cm
Soft tissue injury	Low	Moderate	Extensive	Extensive	Extensive
Contamination	NO	Low	Severe	Variable	Variable
Conminution/ Fracture pattern	No/ Simple	Some/ Simple	Severe/ Complex	Severe/ Complex	Severe/ Complex
Soft tissue coverage	Yes	Yes	Yes	No, requires reconstructive procedure	Variable
Vacular injury injury	No	No	No	No	Yes, require reparation

Figure 2.1: Gustillo and Anderson classification of open fractures [39]

2.2. Open fracture treatment with an external fixator

In the management of skeletal injuries, the treating physician must consider the challenges in achieving adequate stabilization and the complications associated with insufficient mechanical stability. Opting for external fixation for the stabilization of high-energy open fractures, i.e. Gustilo Grade III, provides a quick fixation technique without great complexity [11]. External fixators do not require subspecialists, fluoroscopy or special materials, and have an extensive applicability. In figure 2.2, the clinical picture of a Gustilo open III-C fracture of the humerus is presented, identified by a lack of soft tissue coverage and vascular injury. External fixation used as a temporary fixation method facilitates, in this clinical situation, the vascular reconstruction and protects the repair of the open fracture.

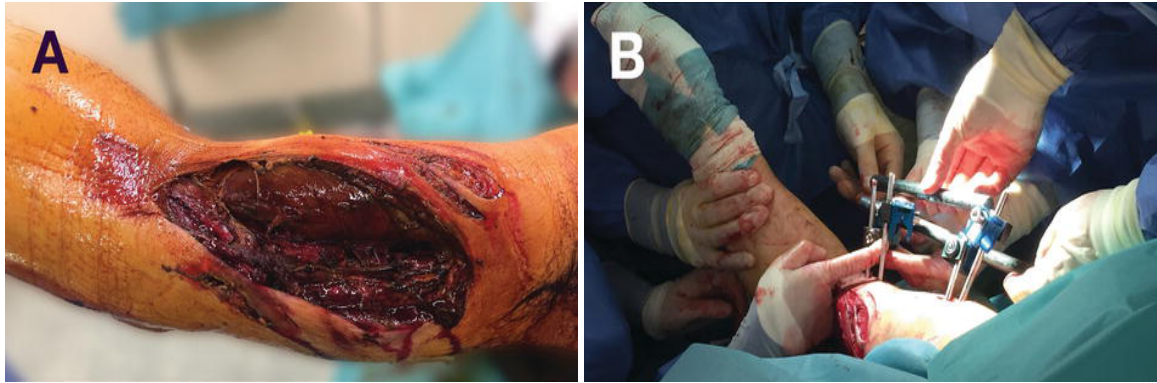

Figure 2.2: Gustilo Grade III-C open fracture of the humerus. A) Clinical image of the humerus fracture. B) Early and initial management of the humerus fracture by temporary external fixation [38].

External fixation can also serve as a definitive fracture treatment method for lower- and upper extremity injuries [8][15]. Open long bone fractures can be treated with an external fixator to provide stability, align the fracture, and protect neurovascular structures. Furthermore, it maintains the limb length and reduces the risk of infection when used as a definitive treatment method [27]. Tibial open fractures are the most common type of open long bone fractures due to its location and characteristics, with an annual incidence of 3.4 per 100.000 [20]. In these type of fractures, alignment of the fracture in a stable environment is required using the most simple and safe approach in order to optimize the wound healing process. Therefore, the application of an external fixator can be useful for wound management, facilitating debridement or other safe wound coverage while providing stability to the open fracture.

2.3. Operation procedure

External fixation is a minimally invasive procedure, requiring general anesthesia, with the primary goal to maintain length, alignment, and rotation of the fracture. This is accomplished by externally immobilizing and fixating the fracture of the patient, in order to allow effective bone healing. It can be installed for provisional or definitive fixation procedures [51].

The technique of external fixation can be applied to stabilize different bones but the technique for application is equivalent for all regions. A full manual can be found in Appendix A. In the first step, *pin placement*, the anatomy of the region of penetration is determined. Two pins in each of the proximal and distal fragments are inserted in the so-called safe zones, one at a distance of 1.5 - 2.0 cm with respect to the fracture site and the other further away, as shown in figure 2.3. Therefore, the risk of penetrating vulnerable neurovascular structures is determined by the anatomy of each individual region. In order to facilitate optimal and safe pin placement, the anatomy of the region must be determined. X-ray offers the opportunity to facilitate this process. In addition, joint cavities should be avoided when placing the pins, as this increases the risk of septic arthritis [21]. The next step includes *incising the skin* over the pin insertion sites. Due to the reduction of the fraction, movement of the pin in relation to the skin might occur. Therefore, extension of the incision to release tension in the skin can be performed, or anticipation by the treating physician prior to the placement of the pins to adjust the skin incision. Alertness is required that skin and muscle are not covered on the pin, as this may lead to inflammation and pin infections [82].

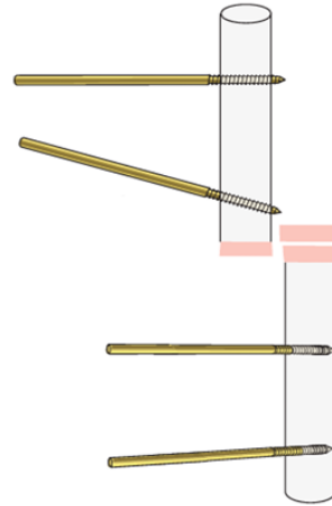

Figure 2.3: Placement of the pins of the external fixator in the proximal- and distal bone fragments.

Next, the treating physician can opt for self-drilling pins or self-tapping pins. *Predrilling* is required when opting for self-tapping pins, demonstrated in figure 2.4. Predrilling of both cortices of the bone prior to the insertion of the pins is essential, and can be supported by a trocar to prevent damage to soft tissues and ensure correct positioning. Cooling is a requirement in this process to prevent heat formation inducing bone necrosis. On the other hand, self-drilling pins can be preferred by the physician to prevent secondary bone damage due to thermal injury. Predrilling is not required in this case. The next step is *pin insertion*, inserting the pin in both cortical bones without surpassing the distal cortex. To ensure the pin grips and penetrates both cortices, x-ray in two planes is recommended. The second cortex should not be protruded too far since this would endanger soft tissues, as illustrated in figure 2.5. Self-drilling pins penetrate the first cortex using a power tool and reach the far cortex, after which they are manually turned into the second cortex to anchor the pin. Self-tapping pins are inserted by hand in the predrilled holes.

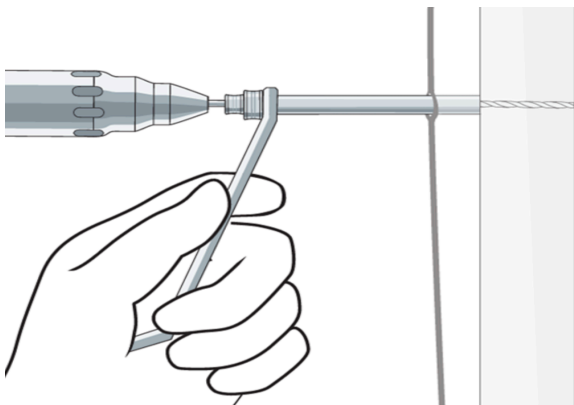

Figure 2.4: Predrilling of both bone cortices when using self-tapping pins, with optional trocar support.

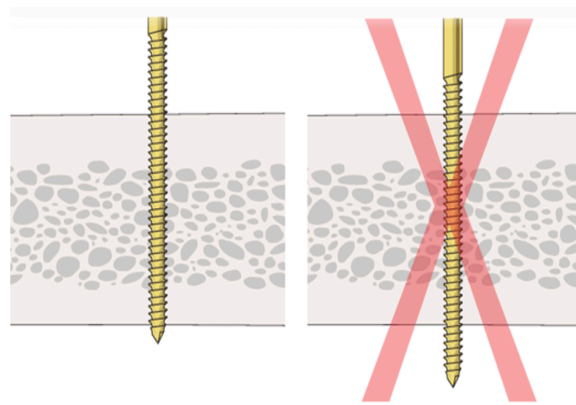

Figure 2.5: Indication of the penetration limit of the distal bone cortex.

The next phase of the external fixator treatment is the *frame construction*. The two pins of each bone fragment are connected, as displayed in figure 2.6, to a connecting bar using the universal clamp. To enhance the stability of the frame, the distance from the connecting bar to the bone should be minimized [29]. Enough room between the connecting bar and the skin should be available to prevent applying pressure on the skin due to limb swelling and allow cleaning of the limb. The two partial frames are connected using a connecting bar and two universal clamps. The snap-in technology of the universal clamp allows a provisional fixation of clamp during the assembly of the system, enabling the surgeon to set up the desired construction. Definitive fixation can be achieved by tightening the clamp using the universal t-wrench attached in the fixation set. A pitfall in the assembly of the external fixator is conflicting of the connecting bars. Interference of the connecting bars might occur as a result of fraction reduction, and should be taken into consideration. *Reduction and fixation* is the next phase, where the partial frames are used as handles and manually reduce the fracture length, rotation and axis, shown in figure 2.7. Using x-ray imaging verifies correct alignment in the anteroposterior and lateral view of the fracture, before the clamps are fully tightened [25]. The stability can be enhanced by attaching additional connecting bars to the the partial frames of the external fixation.

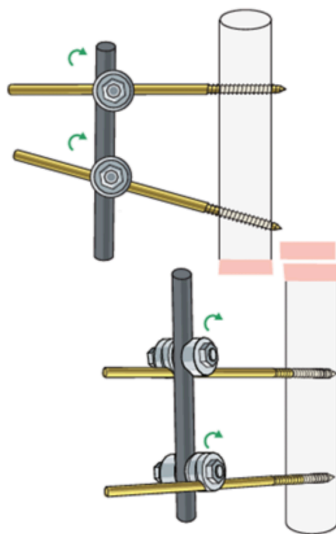

Figure 2.6: Assembly of the external fixator frame by connecting the pins with clamps to the connecting bars.

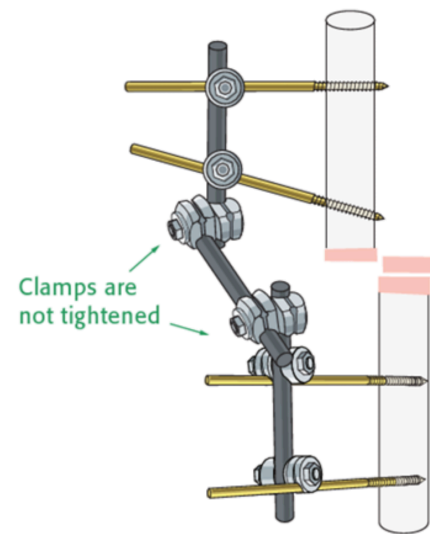

Figure 2.7: Reduction of the fracture after connection of the two partial frames.

2.4. Complications

Many risks are associated with the use of external fixation devices, caused by the external fixator itself or the initial injury that is treated with the device. In general, the complication rate increases with the Gustilo classification of the open fracture [46]. Grade III open fractures, enabling external fixation treatment, have high complication rates. Post-operative complications of Grade III open fractures associated with external fixation treatment include pin-tract infections, non-union, malunion, or delayed union, hardware failure and osteomyelitis [70][9].

Pin-tract infections are the most common type of complications associated with external fixation [13]. An untreated inflammation and subsequent infection at the metal-skin interface, will lead to mechanical pin loosening and ultimately cause instability of the external fixation construction. A proper pin insertion technique could contribute to minimize pin-track contamination of the fracture site. Placing fixator pins away from the injury zone in the subcutaneous bone borders, using sharp drill bits to prevent thermal necrosis, and use adequate skin incision, are considered as important factors minimizing the risk of infection [50]. Also, an unstable construction of the external fixator can result in a higher likelihood to develop a pin site infection. Severe pin-tract infections could compromise the treatment goals and increase the patient morbidity [40]. These include pin loosening, osteomyelitis, joint- or fracture contamination, and increasing pain for the patient.

Commonly reported complications in fracture treatment with external fixators are nonunion and malunion [29]. In a malunion, the bone heals but not in the right position. Nonunion is characterized as incorrect healing of the open fracture, and is a known harmful complication of fracture healing. Excessive interfragmentary movement caused by poor stability of the external fixator can result in deficient callus formation, ultimately leading to nonunion of the fracture [41]. Also, nonunion of the bone fragments leading to prolonging of the healing period may be caused by excessive interfragmentary movements during weightbearing exercises of the patient.

2.5. Weightbearing

Post-operative aftercare of patients with surgically treated open fractures is essential. Many patients are weightbearing with an external fixator as is tolerated by the treating physician [37]. Careful consideration is advisable, as too early post-operative weightbearing may cause nonunion or malunion.

It is important to avoid fracture displacement during the rehabilitation period after the treatment of an open fracture with an external fixator. When a stable frame construction is provided for the patient, weightbearing and functional activity can be encouraged to the patient. During weightbearing axial loading is applied on the fracture site, nonunion, or osteotomy that stimulates osteogenesis [29]. In order to determine the possible amount of weightbearing, the surgeon has to evaluate the stability of the bone fragments, and the rigidity and design of the external fixator. Then the amount of weightbearing can be determined in form of partial weightbearing or full weightbearing. When the condition of the fracture does not allow axial loading, non-weightbearing is prescribed.

The loading and unloading of the limb during the post-operation period, improves the healing process of the fracture. This dynamic process activates the interface between the external fixator, resulting in compressive loading in the axial direction and micromovements at the fracture site [47]. As stated by Wolff in the late 1800s, bone adapts to dynamic loads as opposed to static loads, implying the key role of weightbearing during the healing process [24]. Wolff's law was further enriched with the term dynamization, which is the controlled destabilization of the external fixator to allow the bone to share the axial load. This promotes the callus formation during the bone healing process of the fracture. As the healing of the fracture progresses, the bone bears greater load and less stability is required of the external fixator. This ability to modulate the healing environment during treatment is one of the big advantages of using external fixation for the treatment of open fractures.

Important factors contributing to the optimal healing conditions for the bone are frame stability and bone contact. Poor stability of the external fixator has an adverse effect on the bone healing process. The external fixator serves as a mechanical bridge and is responsible for the load transfer through the fractured bone. Insufficient strength of the external fixator may cause excessive interfragmentary movements during weightbearing, prolonging the healing period and leading to delayed union or non-union of the open fracture [45]. In addition, contact between the fragments is required to allow ambulation and optimize the healing conditions. Exerting weightbearing on a stable frame with a lack of bone contact will result in stress-shielding of the bone. Hence, the full axial load is transferred through the pins and external construction, leading to an increased relative motion at the skin interface. These movements often cause pin loosening and infection [29]. Furthermore, this lack of bone contact between the fragments disallows compressive loading and micromovements at the fracture site, adversely affecting the healing process of the open fracture.

3

Method

The structure of the development process applied in this master degree project is based on the generic product development process as described by Ulrich and Eppinger [73]. Adjustments were made to the generic development process and were complemented with specific methods related to user-centered design were needed.

The development process

Since the project is based on a functional prototype which is still under development, it has throughout the process been of great importance to take opinions of clinical experts in careful consideration and adapt the process accordingly. The approach of development was iterative and can be characterized by learning along the way. Clinical and functional insights have been transformed into conceptual solutions which were evaluated and modified throughout the process in continuous consultation with the clinical- and engineering team. The structure of the development process of the prototype is presented in figure 3.1.

The concepts were evaluated based on the functional requirements and further developed to solve each of the sub problems. In the next phase of the development process, a material analysis was performed to determine the most applicable material for this application. Then the mechanical behavior of the clamp was assessed based on situations to which the clamp is exposed. The final design of the concept clamp was manufactured and mechanically tested to analyze the performance of the prototype. In the final step of the development, the overall design was evaluated and improvements were considered.

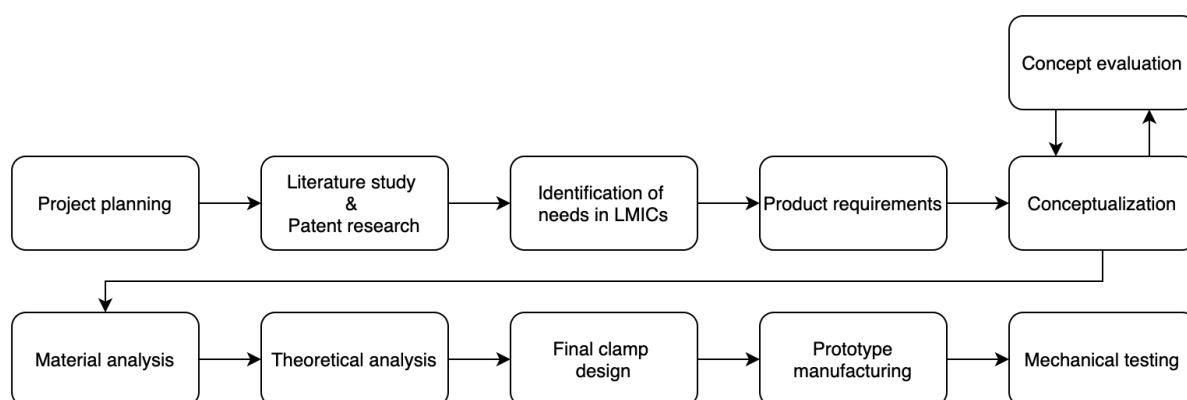

Figure 3.1: Flowchart describing the design process of the thesis project started in February 2020.

3.1. Project planning

In 2019, a collaboration was set up between Global Surgery Amsterdam (GSA), the Amsterdam University Medical Center (AUMC), Foundation MEDIC and the TU Delft with the goal to develop an external fixator for LMICs. The final prototype resulting from this project, formed the starting point of this thesis. The planning of the thesis project was discussed with the clinical and technical supervisors. A literature study of three months was followed by a research study with a duration of six months. The details of this nine month project were specified in consultation with the supervisors of the TU Delft and the AUMC. Together with the clinicians of the AUMC the developed prototype clamp was evaluated and potential improvements in the design were identified. The conclusion of this evaluation formed the foundation for this thesis.

3.2. Literature study & patent research

An initial literature study was conducted to gain insights in the external fixation method as a treatment for open fractures. This was supplemented with a patent search, to map the state of the art around external fixator systems and assess their application in low-resource settings. The most important discoveries from this literature study and patent research are covered in chapter 1.

After gaining understanding of the currently available external fixator systems, the first step of the development process was identification of the customer needs followed by specific requirements for the product.

3.3. Identification of needs in LMICs

The needs can be distinguished between functional and non-functional requirements. In order to gain insight in both types of requirements, four sources were used as input for this thesis:

- Design requirements based on a literature review and patent research.
- A conducted survey on practical experience with open fracture treatment among surgeons in LMICs.
- Predecessor three-way-clamp prototype to assess the viability of the design.
- Workshops with medical doctors to capture their hands-on experience with open fracture treatment in LMICs.

A performed literature study and patent research provided guidelines and best practices on the subject of safety, functionality, stability, cost-effectiveness, and weight.

Prior to this thesis, a survey was conducted among 21 surgeons working in LMIC hospitals to gain insight in the treatment of open fractures. The outcomes of this survey served as input to draft the functional requirements.

One of the outcomes of the survey was the manufacturing of a prototype. The design of this prototype served as a precursor for this thesis.

Numerous requirement gathering sessions were conducted with more than ten clinical physicians from GSA and the AUMC, involved in the development of sustainable solutions in global surgery. Their hands-on experience was captured and included in this thesis.

Finally, based on the inputs prioritization of the requirements was done. These prioritized requirements were used as evaluation throughout the development cycle.

3.4. Product requirements

Based on the defined needs from the previous step the product requirements were defined. These requirements served as input for the prototype development.

3.5. Conceptualization

The concept generation phase was started by comparing the MEDIC foundation clamp with the Hoffmann 3 clamp. During this brainstorm sessions, the importance of individual components were discussed and improvements of the design were considered. Using SolidWorks 2019, concepts were generated based on the list of requirements that was set up. Throughout this process the concept designs were discussed and evaluated with the engineering team and the clinical team. Adjustments were implemented and features were enhanced by challenging the product requirements.

3.6. Material analysis

The use of materials influences several of the product requirements, such as the cost-effectiveness, functionality, stability, and weight. Analyzing the best practices led to a focus group of three materials to be considered. Subsequently, a material analysis was performed using CES EduPack 2019, based on the following criteria:

- Price
- Stiffness
- Density
- Available medical grade

This analysis reduced the number of suitable materials from 906 to 17. Considering the manufacturability and costs, this number was further reduced to the final material choice.

3.7. Theoretical analysis

To evaluate the theoretical mechanical behavior of the developed concept in chapter 6, two analysis were performed:

- A finite element analysis (FEA) was performed in SolidWorks 2019.
- A clamp bolt analysis to determine the required threading in the lower component.

SolidWorks 2019 was used to perform a FEA of the conceptual clamp. The chosen material properties from the previous step were assigned to the clamp concept, and was subjected to two specific test cases to validate the behavior for two chosen use cases:

1. Interaction between the screw and upper component as a result of definite fixation.
2. The effect of tibial weightbearing on the clamp concept.

The required thickness of the lower component to provide sufficient stability and safety was determined using calculation method.

3.8. Final clamp design

The final clamp design was acquired by bringing together the outcomes of previous steps and was presented in a 3D rendering.

3.9. Prototype manufacturing

Two manufacturing techniques were considered for the fabrication of the prototype: 3D printing and computer-numerical-control (CNC) machining. These techniques allowed manufacturing of the concept design out of the chosen material. These were chosen as a result of discussions with experts of the department of materials and engineering as well as external experts from the manufacturing industry. The requirements for the selection of the suitable production method were production time, feasibility, and costs.

Based on this assessment it was concluded that CNC machining was the most viable option for manufacturing. A manufacturer was selected, that mastered this technique.

3.10. Mechanical testing

To analyze the performance of the prototype and assess the stability it provides, the clamp was subjected to a set of two mechanical test cases. The prototype clamp was mechanically compared with a Hoffmann 3 clamp, a recognized external fixator in modern hospitals. Testing of the clamps was based on six parameters of movement controlled by the external fixator clamp.

4

Identification of needs in LMICs

In February 2019 a collaboration started between Global Surgery Amsterdam (GSA), AUMC, and the TU Delft to develop a so-called 'Lifebox-idea' to treat open fractures. The aim of this collaboration was to design an external fixator to be implemented in every hospital in LMICs to perform the necessary interventions, with the minimally needed components, and materials that can also be developed in own countries. The product needs, form the guideline throughout the conceptualization process. Evaluation of the concepts was performed in an iterative approach with surgeons and engineers, guided by these functional requirements.

4.1. Lifebox case

The mission statement of this project was initiated by the so-called Lifebox case, tackling unsafe surgery in LMICs. In 1999, hospital errors reportedly killed 100,000 people a year in the US, and surgery in LMICs was estimated to be up to a thousand times more dangerous. A lack of appropriate equipment and training meant that millions of life-saving operations were actually causing harm. Anaesthetists observed that patients in LMICs died on the operating table, slipping into cardiac arrest due to an undiagnosed lack of oxygen. In 2004, Lifebox conducted a trial in multiple countries to test the feasibility of global pulse oximetry, which is a monitor that clips onto the finger and sounds an alarm at the slightest change in patient's oxygen level, shown in figure 4.1. They indicated that despite poor distribution networks, inappropriate machines, lack of training and education, pulse oximetry had the potential to be successfully adopted in LMICs. With features applicable for low-resource settings; low maintenance in an environment with limited biomedical engineering, robust enough to withstand falls, and available at marginal costs. Supplemented with protocols and education materials, over 13,000 pulse oximeters to over 100 countries were distributed, improving the safety of anaesthesia in LMICs [44].



Figure 4.1: Pulse oximeter developed by Lifebox to enhance the safety of anaesthesia in LMICs

4.2. Collaboration with TU Delft and GSA

This Lifebox initiative raised the question if something similar could be developed for the treatment of open fractures. Two researchers, Maurits Vriesendorp and myself, both master students Biomedical Engineering at the TU Delft were supervised by Drs. Matthijs Botman of the AUMC. In the first analysis step of this collaboration, the current solutions for external fixation had to be evaluated and compared. Therefore, an industrial advanced system, the Hoffmann 3, was compared with the external fixator developed by foundation MEDIC. The Hoffmann 3 was the latest type in the series of the external fixators developed by *Stryker Corporation*. The modular model developed by Foundation MEDIC was used because this is a non-commercial foundation, focused on providing medical goods and services to people in need in economically underdeveloped countries. They collect and repair medical equipment and goods, and make equipment available for developing countries on an on request basis at marginal costs.

The two external fixators were compared based on a Harris profile, shown in Appendix B, filled in by two researchers and the supervisor of the research. Weighing properties were given to the functional requirements, based on importance expressed in literature. These can be found in Appendix C. However, the experience of surgeons in LMICs was not taken into account in this analysis. Therefore, considering the importance of the experience of surgeons in LMICs regarding the use of external fixators, a questionnaire was set up. A total of 21 surgeons with specialisms varying from orthopaedic/tropical/trauma surgeons to technical designers, filled in the questionnaire. They were asked about their experience with the use of the external fixator, the problems that they encounter during the treatment of open fractures, the available resources, and how to improve open fracture treatment in LMICs. The results of this questionnaire and the set up Harris profile provided insights in the use of external fixators in LMICs and how they could be improved.

One of the current problems, indicated by 40% of the questionnaire respondents was that multiple parts of different external fixators were used. Therefore, the need to implement a standardized set of appropriate external fixation technology was evident. To provide the whole solution for external fixation in one box, a so-called 'Lifebox solution', included with clear manuals for treatment, and improved design solutions for the external fixator are of utmost importance. The cost-target was set at a maximum of 500,- for the universal box. Derived from this initiative, the goal of this project was to develop a low-cost solution with respect to open fractures.

In consultation with Drs. Botman, and the results from the questionnaire and the Harris profile, it was decided to tackle three problems:

- A three-way clamp which can be used as bar-bar as well as pin-bar fixation.
- A depth utility that can be used when a pin is drilled into the bone.
- A minimal box, including the necessities to solve most of the open fracture cases presented to the surgeon.

For every problem a list of requirements was set up, shown in table 4.1.

Table 4.1: List of requirements for the three identified problems identified to improve open fracture treatment.

Req. ID	Three-way clamp	Depth utility	Minimal box
Req. 1	Three slots (4, 5, and 8mm)	Easy fixation	Good overview of materials
Req. 2	Easy to sterilize	Not easy to get lost	Sterile take out mesh
Req. 3	Generic, easy to manufacture	Not interfering with drilling	Room for all essentials
Req. 4	No small parts which can get easily lost		Clear manual provided for usage
Req. 5	Low-cost		
Req. 6	Withstand exerted forces (1 - 1.5 times body weight)		

For each problem a prototype was designed and manufactured. For the depth utility a rubber ring was made which could be fixated around the drill bit, shown in figure 4.2. The height of the depth utility would be the same thickness as the cortex of the cortical bone. This would provide the treating surgeon with information how far the pin had to be inserted into the bone. This solution provided both simplicity and easy fixation. After consultation with expert surgeons, in both high-income countries (HICs) and LMICs, the minimal amount of components was determined for the treatment of open fractures in LMICs. This minimal box set, presented in figure 4.3, consisted of: 8 clamps, 2 connecting bars, 4 pins of 4mm, 4 pins of 5mm, 2 pin bars, 20 depth meters, a battery charger and a drill. The developed prototype of the three-way clamp is shown in figure 4.4. This prototype of the three-way clamp was small in size (30mm diameter), provided easy sterilization because of the uncomplicated disassembly, and could be easily manufactured with a radius mill.



Figure 4.2: Depth utility prototype developed for LMICs, attached to fixator pin



Figure 4.3: Minimal box solution for the treatment of open fractures in LMICs

Although the prototype in this stage showed promising results in terms of usability, the durability and strength of the prototypes were not analyzed. Therefore, this prototype could serve as a starting point of the development of a low-cost external fixator clamp, but could be significantly improved. The development of the three-way clamp was considered to be the area with the highest potential of improvement of the external fixator for application in LMICs. The depth utility and minimal box were clearly fundamental when adopting an external fixator in LMICs, but were not taken into account in this thesis.



Figure 4.4: The three-way clamp prototype, the developed product in a first collaboration between the TU Delft and GSA.

4.3. Evaluation of requirements

This section describes how the requirements drawn up earlier were evaluated and prioritized in further development of the clamp design.

The harris profile, the three-way-clamp, and the questionnaire served as input for this evaluation. In addition, the patent research, performed prior to this thesis, was taken into account in the prioritization of the requirements. In this patent research 12 state of the art external fixator systems were compared and their applicability was assessed in LMICs. An overview of the external fixator systems is provided in Appendix D and the resulting harris profile is shown in Appendix E. Next, prioritization of the requirements was done based on these inputs and in consultation with the clinical supervisors. These prioritized requirements were used as evaluation throughout the development cycle.

The costs was considered as most important factor after evaluation of the requirements. Therefore, minimizing the costs was the primary goal of the development process, including the constraints that it must meet the functionality, safety, stability, and minimal weight.

5

Product requirements

The three-way clamp prototype is designed based on the needs expressed by surgeons in LMICs, supplemented by suggestions from surgeons from HICs. These design considerations are enriched with the findings from the literature study and patent research, performed prior to this thesis project. The product specifications are divided into technical specifications and design specifications.

5.1. General specifications

Throughout the design and development process of the clamp, functional and physical factors need to be considered. The technical specifications serve as a guideline during the design process, developed over time and are sometimes subject to change as new insights are gained.

When deciding on treatment in LMICs cost is one of the most important factors [57]. To ensure adoption of the new clamp type in low-resource settings, minimizing the cost has to be strongly considered. Patients in LMICs are extremely poor and have to bear the cost of their treatment. Therefore, the effect on the costs should be weighed heavily when implementing design changes. Also, the ease of manufacturing should not be limited by the complex design specifications of the clamp. Difficult feature details could lead to higher manufacturing costs, causing the production techniques to be accounted for.

The most important factor of the external fixator is to provide stability to the bone. Therefore, the clamp should withstand the stresses that it is exposed to during the healing process of the patient. External fixators are applied quickly in emergency situations to provide stability and alignment to the open fracture presented. Therefore, a strong connection between the pins inserted into the bone and the connecting bars should be assured.

To treat open fractures of the upper- and lower extremity, the functionality of the clamp has to be taken into careful consideration. From the patent research twelve different external fixator systems are noted, and the functionality of the clamp types are examined. The main functions are to form the connection between the pin and the connecting bar and to ensure secure fixation. Furthermore, contemporary clamp designs allow versatility of constructs, and are easy to use.

In medical device development safety is paramount. It is important to assure the medical device meets its intended use and can not cascade severe harm to its user and the patient. Both for the treating physician during the operation, as for the patient after the placement of the external fixator, the clamps should not cause injuries or other adverse effects.

Another important character is the low weight of the external fixator. Minimizing the weight of the external fixator enhances the comfort of the patient, and provides improved conditions for bone healing. Tomanec *et al.* states that saving weight of approximately 30% in comparison with a steel construction, results in a 10% reduction of the heart rate and thus oxygen consumption for the patient. Also, the

walking speed of patients increases [71].

5.2. Design specifications

The design specifications given for the project are in line with the first generated prototype. Further development of the clamp should enhance the functionality of the clamp. A requirement of the clamp is its universality, allowing both pin-bar as bar-bar fixation using one clamp type. For this reason, it is chosen to opt for two pin slots and one connecting bar slot. Tibial or femur fractures are treated with 5- or 6mm pins, as it is advisable to keep the pin size within a third of the bone diameter [31]. However, forearm fractures are treated with 2.5 – 4 mm threaded pins [26]. To comply with these differences in functionality a universal clamp design is chosen, comprised of three slots of 4mm, 5mm and 8mm respectively. The diameter of the slots for the pins are assigned to be 4mm and 5mm, enabling fixation of both upper as lower extremity fractures. The connecting bar slot has a diameter of 8mm, providing stable extracutaneous spanning of the pins.

In order to meet the requirement to perform universal fixation, the design of the prototype should enable the fixation of two components. Both pin and connecting bar fixation should be provided with each individual component, and this must be possible separately from each other.

In hospitals in LMICs there often are logistic problems and lack of adequate maintenance, according to the tropical doctors associated with GSA. A common problem is the loss of equipment, as a result of lack of logistics and lack of available equipment. Therefore, it is important to develop a recognizable Lifebox set for the treatment of open fractures. Furthermore, the components of the clamp should be kept together when the clamps are not in use, as this would reduce the risk of losing components.

As a result of the discussions with the clinicians, the ease of use of the clamp can be increased by implementation of a spring system. This snap-in technology would enhance the ease of use and promotes quick fixation of the external fixator during the operation. As seen in several external fixator systems analyzed in the patent search, this spring technology provides provisional tightening of the clamp during the assembly of the external fixator. While the clamps are provisionally tightened, the treating physician is able to manipulate the components to obtain the desired construction. When the desired external fixation has been constructed, definite fixation can be achieved by fully tightening of the clamps.

Since the development of the prototype is intended for application in LMICs, the simplicity of the components must be taken into account. The manufacturing of components in LMICs is facilitated by making use of general components and tools to construct the external fixator. Also, replacement and repair of components is simplified in low-resource settings when using general components and equipment. Therefore, the ease of manufacturing must be kept in mind, using simple components which can be made of materials suitable for application in LMICs.

Conceptualization

The concept generation of the prototype is divided into different parts solving specific sub problems. Throughout the design process, the development of the prototype is guided by the set up general- and design requirements. At first, the functionality of the latest prototype developed is evaluated. The clamp of the external fixator should provide optimal stability while taking into account the costs, weight, and functionality. To guide the development of the prototype during the conceptualization, the following three subproblems are defined:

1. Enhance the stability provided to the bone
2. Limit the weight of the overall clamp design
3. Increase the functionality of the universal clamp

6.1. Stability enhancement

The three-way clamp prototype consists of an upper- and lower component containing three sloths with diameters determined in advance and held together by a M8 screw. In between these components a disk is located to facilitate the clamping of two components. Accordingly, both pin-bar as bar-bar fixation can be carried out with one type of clamp.

The disk in between the two components is a smooth disk, with a thickness of $2mm$ and a diameter of $30mm$. In order to enhance the stability of the pins and connecting bars when they are secured with the clamp, sloths are implemented in the disk. The design of the clamp is shown in figure 6.1, displayed in isometric-, top- and bottom view, respectively.

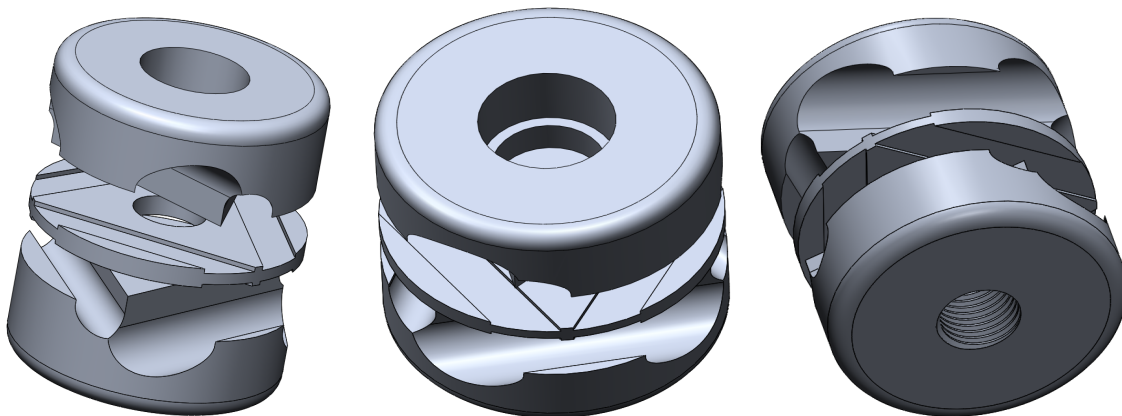

Figure 6.1: First clamp concept; a) Isometric view, b) Top view, c) Bottom view

In order to improve the distribution of the forces on the clamp, the sharp edges of the upper- and lower component are rounded of. The wear resistance of the prototype increases, as the distribution of the forces on the clamp is improved.

The disk in this first concept has sloths with a thickness of 0.5mm and a width that corresponds with the diameter of the sloths of the upper component. As a consequence is the movement in the lateral direction restricted, enhancing the stability of the pins fixated in the clamp concept. The friction disk in this stage has several drawbacks. First, it is limited with respect to orientation, as it is required to be aligned with both components in order to fit the connecting bar and pin. Generally, the pins are placed perpendicular to the connecting bar, and this is contrary to the dimensions of the disk.

Therefore, consideration is given to the possibility to provide enhanced stabilization regardless of the orientation of the disk. This leads to the introduction of the friction disk incorporated in the second clamp concept, shown in figure 6.2. This friction pattern on the disk increases the local pressure, which increases friction between the pin or connecting bar and the clamp component. The friction edges are separated 0.5mm with respect to each other in the x- and y-direction and have a height of 0.25mm . This friction pattern enhances the resistance of the pin in the clamp against torsional and axial forces.

Another modification compared to the previous concept are the angular cut-outs in the clamp instead of the round compartments. This three-point fixation ensures that the local pressure increases, which increases friction between the pin or connecting bar and the component of the clamp.

Furthermore, the adjustment was implemented to round of the edges of the prototype clamp. In practice, no corner is an angle where two surfaces exactly connect with each other, but there is often a transition. Implementing such a transition can be functional and aesthetic. On a functional level, applying such a transition generally enhances the strength of the product, because forces do not concentrate on one place and can thus be better transferred through the material. Furthermore, the radii of the clamp components are rounded of with a radius of $0,2\text{mm}$, because especially inner radii of parts are more likely to crack without rounding.

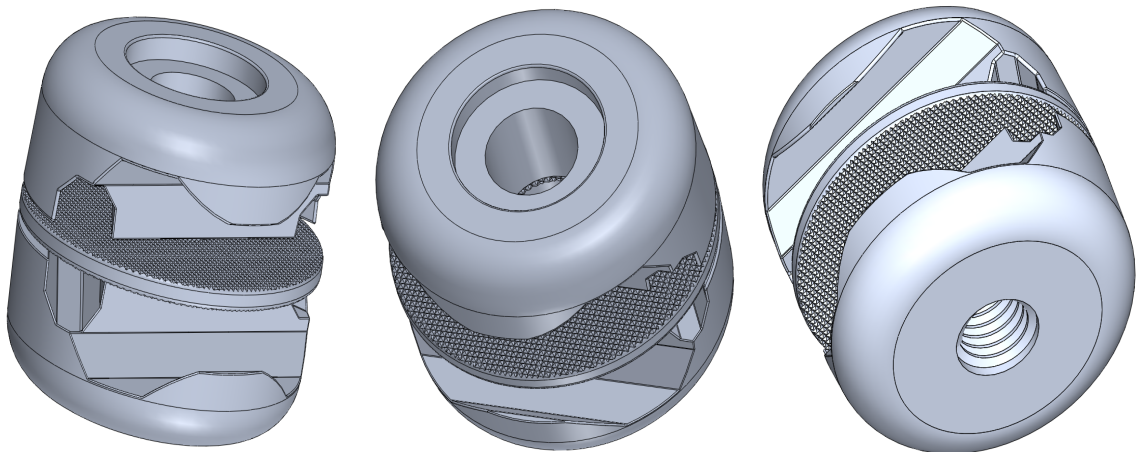

Figure 6.2: Second clamp concept; a) Isometric view, b) Top view, c) Bottom view

6.2. Introduction of spring compartment

Both from the patent research, as noted by the involved physicians, is the implementation of a snap-in system essential to optimize the ease of use. The performed patent search demonstrates that advanced external fixation clamps possess a spring system, which facilitates the provisional assembly of the external fixation construction. To incorporate such a system in the prototype, the different components of the clamp prototype are examined and possibilities are considered in a brainstorm session. During the first brainstorm session a few conclusions can be made. For example, it is determined that

the spring system should provide the suspension effect in both the upper component as in the lower component. In addition, the suspension travel should be high enough to function as a snap-in mechanism, but cannot interfere with the definite fixation of the clamp.

In the next concept of the prototype clamp, the first spring system is integrated in the clamp design. This prototype is shown in figure 6.3. In the upper component of the clamp a spring compartment is implemented with a diameter of 9.5mm and a height of 7.5mm . In the lower component a spring compartment is added with equal dimensions. The connector of the clamp assembly is an M8 screw, equal to the connector of the previous concepts. A bolt at the end of the screw would allow the fastening of the components of the clamp. The upper component of the clamp concept contains three different diameters to tolerate positioning of the M8 screw and spring component. The first diameter is 14mm and has a height of 3.3mm and serves connection between the head of the screw and the upper clamp component. The spring is fitted into the spring compartment with a diameter of 9.5mm and a height of 7.5mm . The function of the last diameter, 8mm , is to fit the component tightly around the M8 screw. In addition, the spring could exert pressure on the plane created by the difference between the radii.

The lower component of the prototype contains a spring compartment with a diameter of 9.5mm and a height of 7.5mm . A second spring is incorporated in this design to ensure a snap-in system in both the upper component as lower component. The radius of the second compartment is 6.7mm and is M8 threaded.

Evaluation of the two-spring system of the third clamp concept results in two conclusions. Firstly, the spring compartment interferes with the threaded compartment. The implementation of a spring between the threaded section and the end nut of the screw, results in contradictory functions. The spring mechanism ensures partial loosening of the lower component with respect to the end nut, in contrast to the threaded section which functioned as a fastener of the component. Secondly, the amount of threads in the lower component would limit the fastening capacity of the clamp. In order to achieve secure fixation in a single treatment with an external fixator clamp sufficient threading should be provided. In addition, the amount of threading should allow multiple fixations using the clamp, preventing fatigue of the threaded section of the clamp. In the current concept the amount of threading is 4.5mm , which is considered very limited. In order to improve the tightening capacity of the clamp to avoid thread failure would occur, this is reconsidered in further development of the clamp concept. Additional analysis of the required threading of the component is assessed in chapter 8.

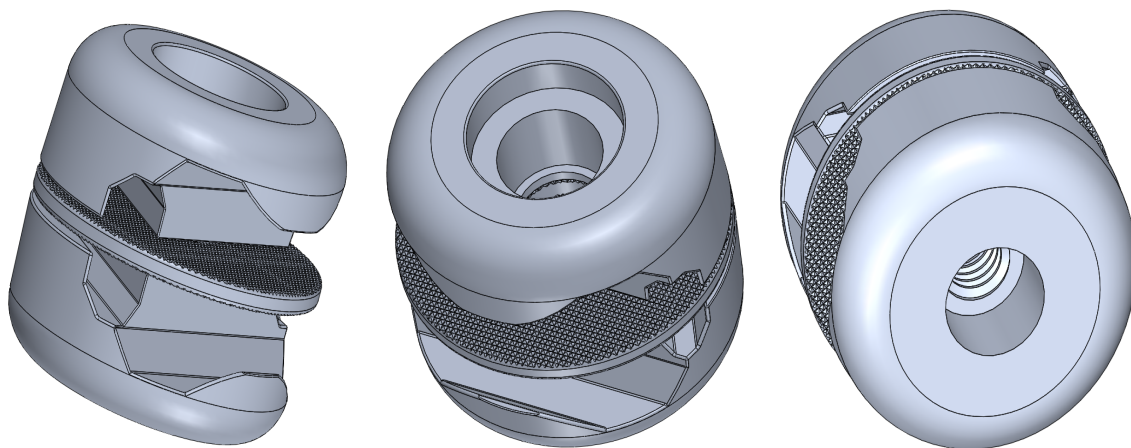

Figure 6.3: Third clamp concept; a) Isometric view, b) Top view, c) Bottom view

6.3. Weight reduction

A critical factor in the development of an external fixator system is to limit the overall weight. Different approaches can be considered to minimize the weight of the clamp. The use of materials can be altered in order to optimize the total weight of the clamp. Another option is to adjust the design of the clamp in order to reduce the weight. In this stage of the design process, the used material is AISI 316 Annealed Stainless Steel. Further judgement on use of materials is described in chapter 7. The weight of the third clamp concept was 86.614g and acts as a benchmark to optimize weight reduction.

The clamp concept is evaluated and it is considered which components could be modified in order to achieve the most weight reduction. It is taken into consideration that the alterations in the design may influence the ease of manufacturing and increase the costs. The effect of weight reduction on the costs and ease of manufacturing is noted in this stage, and is evaluated at a later stage of the development process.

The round edges of the upper and lower component are considered to affect the weight of the clamp, while not contributing to the stability the clamp provides on the pin or connecting bar. Therefore, the round edges superior to the pin- and connecting bar compartments are cut off at an angle of 45°. A fillet with a radius of 4.5mm is applied to round the external face of the connecting bar compartment. A radius of 4.0mm is applied for the pin compartments. These adjustments in the upper- and lower component of the clamp results in the fourth concept, shown in figure 6.4.

The changes in clamp design to reduce the weight results in a weight reduction of 10.039g, which brings the total weight of the clamp to 76.575g. Assuming the use of six clamps in the assembly of a standard unilateral fixator, this brings the total weight reduction 60.234g. Besides the positive effect on the weight of the clamp, it favors the aesthetics of the clamp design.

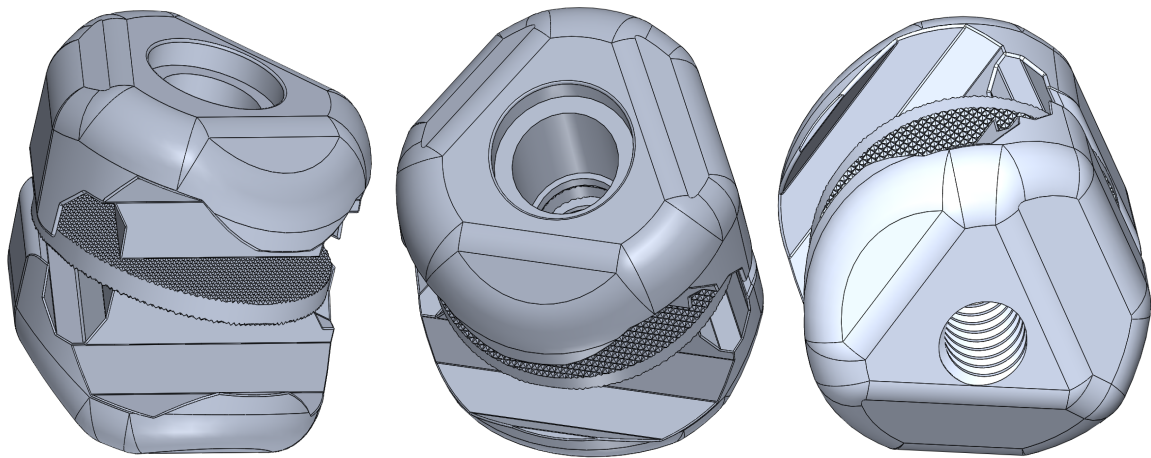

Figure 6.4: Fourth clamp concept; a) Isometric view, b) Top view, c) Bottom view

6.4. Increasing functionality

The functionality is an important aspect in order to be successfully adopted as an external fixator clamp. This relates to the ease of use and stability it provides in the external fixator assembly. One of the conclusions from the patent research is that a snap-in system would improve the ease of assembly during the operation. In section 6.2 a first concept is introduced for the implementation, which is further discussed in this section. Because of the several limitations of this concept, other locations are considered for the snap-in technology. One option is to place the spring system in the upper compartment, comparable to the design of the fourth clamp displayed in figure 6.4. The drawback of this design is the

limited spring effect in the lower component of the clamp design. When the clamp is not fully tightened and a connecting bar or pin is clamped in the upper compartment, the spring effect of the lower compartment is limited. To increase the spring effect of the clamp, the distribution of the spring force has to be evenly shared over both components. In addition, this suspension system must also be able to distinguish between the components in order to create the spring effect in both the upper- as lower component.

With these considerations and requirements in mind, the fifth clamp concept is developed. The friction disk underwent a major change in this phase. Instead of one friction disk, it is split into two separate identical components. Because of this design adjustment a spring compartment could be established inside the two friction disks. Two different clamp designs are considered using different diameters for the spring compartment. The compartment in the first clamp design, shown in figure 6.5, has a diameter of 12mm and allows the placement of a helical compression spring. The combined height of the friction disk compartment is 17mm , allowing the placement of small helical compression spring. This type of spring is the most common spring type of the category in which the force increases when the axial length decreases.

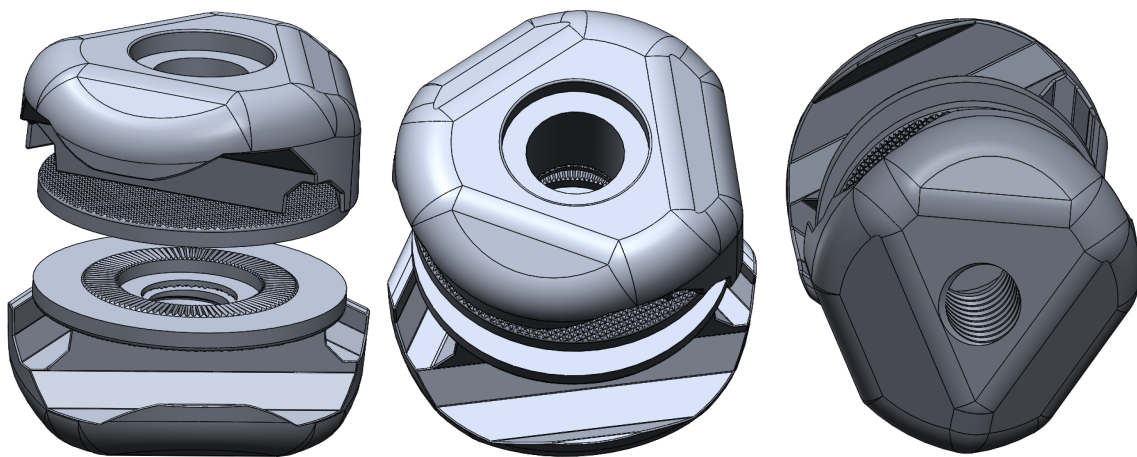

Figure 6.5: Fifth clamp concept, helical compression spring option; a) Isometric view, b) Top view, c) Bottom view

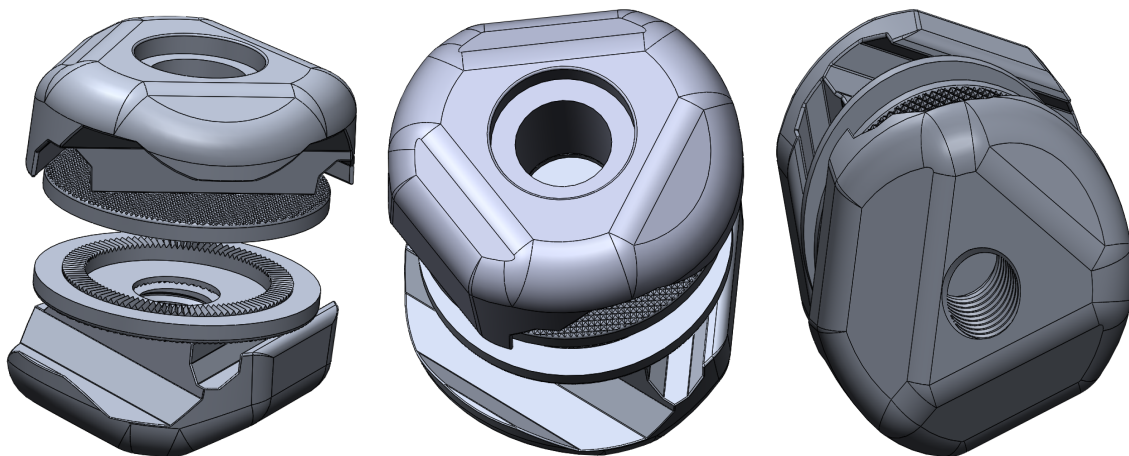

Figure 6.6: Sixth clamp concept, disc spring option; a) Isometric view, b) Top view, c) Bottom view

The other concept, shown in figure 6.6, contains a 17mm diameter compartment. In this chamber of the friction disk, disc springs can be installed. Disc springs, also called Belleville springs, have a

holed cone shape which is axially symmetric. When axially loaded, the cone angle is reduced of the disc spring. When forces are high and deflections relatively small, disc springs are often a better alternative compared to helical compression springs. In addition, limited radial space also speaks in favor of disc springs [43]. Disc springs can be used as a single disc, but also allow stacking in series or parallel. Assembling disc springs in series increases the deflection, opposed to the increased force when parallel stacked. A combination of parallel and series stacking is also a possibility. In addition, the cone and the thickness of the disc spring affects the amount of force it generates. When the disc spring is in flattened condition, the reduced cone angle moves the bearing point towards the centre. This results in the stiffening of the disc spring.

The design of the friction disk of the two concepts, shown in figure 6.5 and 6.6, differ with respect to the inner diameter of the spring compartment. The other components of the friction disk are equal. The friction plane, clamping the connecting bar or pin to the upper and lower component, is identical in both concepts. Moreover, a serrated ring with a height of 0.5mm prevents rotation between both friction disk components.

6.5. Final clamp concept

The conceptualization of the external fixator clamp, is performed guided by the specifications drawn up in advance. The three subproblems are approached during this iterative process. Design considerations are discussed with engineers from the TU Delft, and the clinical applicability is examined with surgeons from the AUMC.

The sixth clamp concept, whereby the disc spring is included in the prototype, is considered as most promising for application in LMICs because of their high loads in a relative small amount of deflection. Therefore, evaluation of this prototype is performed and additions leading to design improvements are considered. As indicated in section 4.2, leads the use of multiple parts of different external fixators to problems in LMICs. In order to prevent the loss of components of the prototype a M8 screw is adjusted, shown in figure 6.7. A total of 14mm of a 55mm M8 screw is rounded of to a diameter of 5.5mm and an end cap is soldered on the end of the screw component. This prevents components to detach from the clamp and keep the clamp system together, which reduces the risk of losing components in chaotic situations.

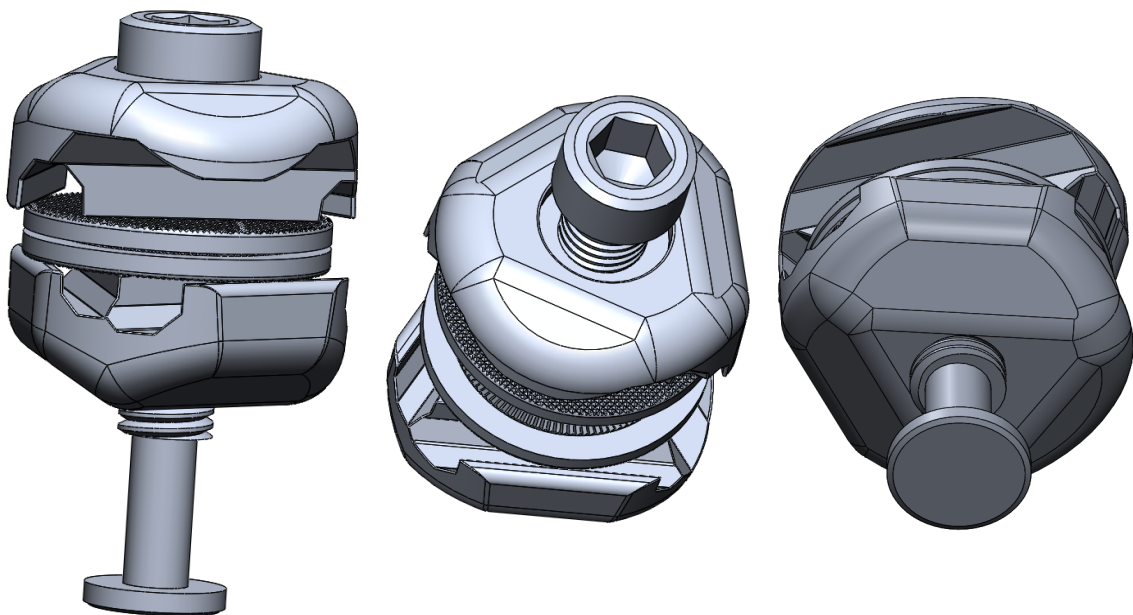

Figure 6.7: Final clamp concept; a) Isometric view, b) Top view, c) Bottom view

In addition, the screw in this clamp concept facilitates the sterilization of the clamp after use on the patient. The lower component of the clamp can be unscrewed and thereby falls into a compartment. The outer radius of the screw is smaller in comparison with the inner radius of the clamp component, which simplifies sterilization. This so-called sterilization position of the clamp, shown in figure 6.8, facilitates the sterilization of the disk springs in between the two friction disks. Also, the sterilization prospects of the inner compartment of the lower component are enhanced. In LMICs often autoclaves are used to effectively and cost-effective sterilize medical equipment. This method requires high temperatures and steam to kill microorganisms to protect patients from infections and minimize risk to staff. In order to optimize quality control and minimize infection risk, the ease of sterilization is considered a crucial factor to receive clearance from the Food and Drug Administration (FDA) [36]. In order to roll out the concept clamp into an actual product and becoming FDA approved, this ease of sterilization contributes to receiving clearance from the FDA.

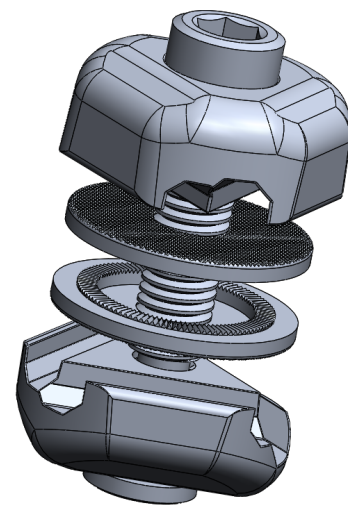

Figure 6.8: Final clamp concept in sterilization position, isometric view

The developed concept incorporates the requirements determined in advance of the conceptualization process. In comparison with the three-way-clamp prototype the stability is enhanced by introduction of the friction disk and the angular cut-outs. Modification of the upper- and lower component of the clamp results in an overall weight reduction of $10.039g$ per clamp. The introduction of a spring compartment in the clamp promotes the ease of use and enhances the functionality of the clamp design. In order to further evaluate the performance of the clamp design, it is necessary to choose the optimal use of materials for this application. Subsequently, based on the determined choice of materials the performance of the final design of the prototype can be evaluated.

7

Material Analysis

Metals are essential for orthopaedic implants, bone fixators, artificial joints and external fixators since they substitute for the functions of hard tissues in orthopaedics [34]. The clamp is one component in the assembly of the external fixator system, which contributes to providing stability to the open fracture of the patient. In order to analyze the prototype for this application, the choice is made to standardize the other components i.e. connecting bars and pins, to reduce the measurement errors and understand the performance of the clamp. Hence, the connecting bars and pins are made out of stainless steel 316L.

For the use of materials suitable for this application, the mechanical properties are considered based on their importance expressed in literature. The following list of requirements is set up: low-cost, tolerable young's modulus (YM), minimal weight, corrosion resistant, ease of manufacturing. As previously mentioned, costs is one of the most important factors when deciding on treatment in LMICs. In order to provide sufficient stability to the open fracture, a tolerable YM is required. Excessive stiffness negatively affects bone healing, but insufficient stiffness leads to disproportionate interfragmentary movements [64][65]. A critical aspect in the treatment of open fractures is the limited weight of the external fixator system [63]. Therefore, a minimal density is desired for the external fixator clamp. Moisture, body fluids, and cleaning reagents may lead to significant corrosion in external fixator components [12]. External fixator failure or impairment of healing can be the consequence of corrosion of fixator components. Opting for corrosion resistant materials, consequently improves the applicability in LMICs. Lastly, the working principle of the prototype in this stage of development has to be proved. To reduce the manufacturing costs, workable materials are preferred to reduce production time and the number of required manufacturing proceedings.

In addition, the patent search performed prior to this research project is used as an indication for the material usage regarding external fixator clamps. In this patent search 12 different external fixator systems are analyzed and their applicability in LMICs is assessed. The results show that three materials are used to manufacture the clamps of an external fixator: titanium, stainless steel, and aluminium. Taking the use of these materials into account, further evaluation of materials is considered.

Using CES EduPack 2019, materials are selected based on their mechanical properties and medical applicability. For the selection of data, *MaterialUniverse: All materials* is used from the *Level 3 Bioengineering* database. The next step in the material selection process is selecting the desired maximal or minimal properties. The price is set at a maximum of 2 USD/lb. Regarding the density, a maximum of 30 lb/in³ is used. This search conducts a total of 906 materials, shown in figure 7.1. In order to check how much the output value changes as a result of a change of the input value, a sensitivity analysis is performed. The robustness of this outcome is determined using a sensitivity of 25%. For the input value *price*, this results in a total of 858 and 1017 materials and for the *density* in a total of 906 and 906, respectively. When the materials meet the search criteria, they are displayed with a colour, depending on their alloy type. A grey colour is presented when the material did not meet the criteria.

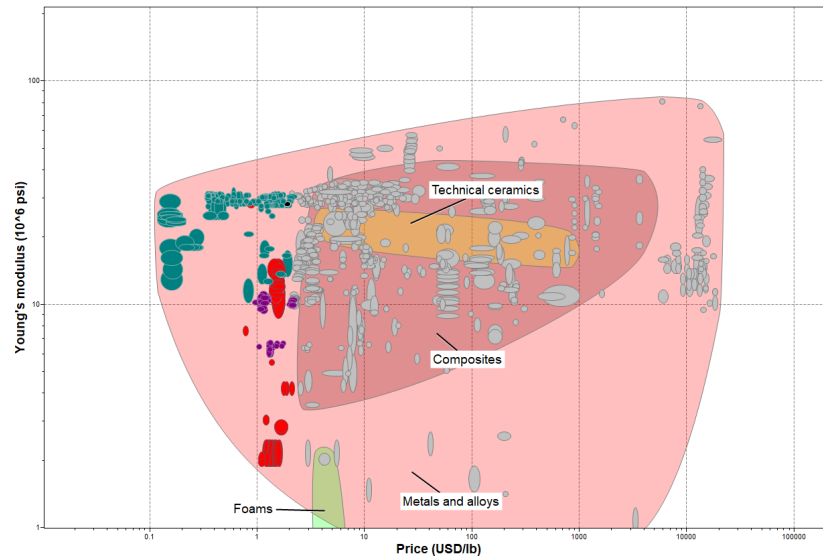

Figure 7.1: Young's Modulus (10^6 psi) vs. Price (USD/lb) of the included materials ($n = 906$) in the EduPack analysis. Grey materials are excluded from the analysis as a result of the set limitations.

Furthermore, commercially available medical grades within this material specification must be available. The material is defined as a medical grade if there is a specific ASTM or ISO medical standard for the material, there is evidence for the use of this material in FDA approved medical devices, or the material has passed tests relating to biocompatibility for medical applications [23].

Also, the materials must be suitable for healthcare applications and specifically for bone fixation and repair. Therefore, the materials have to comply with this specification in the EduPack analysis. This search results in a total of 17 out of 1863 materials. A sensitivity analysis is performed to check the robustness of these outcomes. A sensitivity of 25% is used for the input values price and density. This results in a total of 12 and 17, and 17 and 17 materials, respectively. In figure 7.2, the YM (10^6 psi) of the materials, meeting the requirements of the search, is compared with the price (USD/lb). The aluminium alloys have a range of pricing between $1.01 - 1.17 \text{ USD}/\text{lb}$ with a YM ranging between $9.66 - 10.4 * 10^6 \text{ psi}$. The stainless steel alloys range in price between $0.98 - 2.01 \text{ USD}/\text{lb}$ with a YM varying between $27.8 - 29.7 * 10^6 \text{ psi}$.

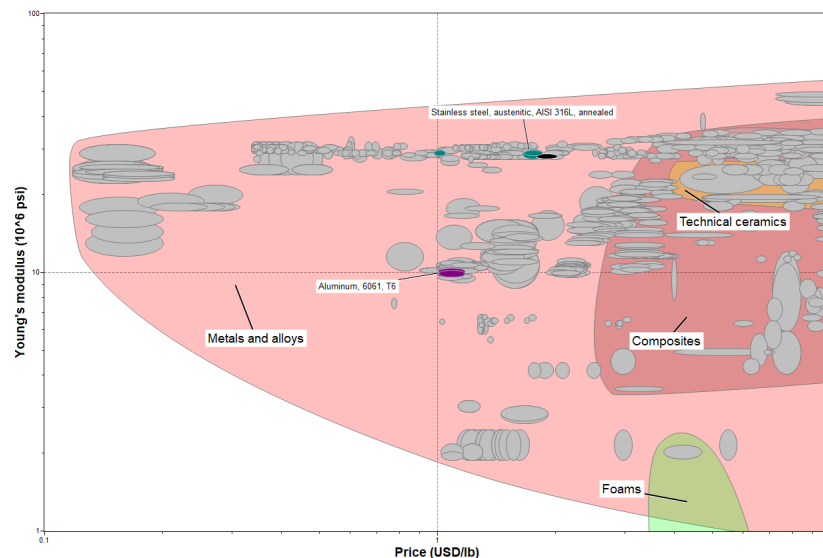

Figure 7.2: Young's Modulus (10^6 psi) vs. Price (USD/lb) of the included materials ($n = 17$) in the EduPack analysis. Grey materials are excluded from the analysis as a result of the set limitations.

Different 6061 aluminium alloys are represented in the results. The general characteristics of this aluminium alloy are the relative high strength, good workability, and high corrosion resistance [6]. Besides this, aluminium 6061 is widely available and used in a wide variety of industries, including aerospace, transportation and medical [18].

Furthermore, the results present different types of austenitic stainless steel. These iron based alloys range from the general purpose 316L which contains a low carbon content, to nitrogen strengthened types of austenitic stainless steel such as BioDur 108 and ASTM F1586 [48].

The material not mentioned above, but widely used in the manufacturing of EF clamps, is titanium. The properties of this metal do not comply with the requirements of the design goal, specifically the need to use low-cost materials. Adjusting the limit for price from 2 to 10 results in a total of 41 materials, including various titanium alloys. Figure 7.3 shows that the price of titanium alloys ranges from 5.81 – 10.8 *USD/lb*, thriving up the manufacturing costs of the external fixator clamp. Additionally, the YM of the titanium alloys range between 4.06 – 17.4 * 10⁶ *psi*, providing more stiffness to the clamp. This is endorsed by Zhao *et al.*, who claims that this composite material provides good stiffness properties for a unilateral fixator [81].

Furthermore, titanium shows high corrosion resistance and a YM about half that of stainless steel which makes it suitable for applications such as bone fixations [34]. These titanium alloys are shown on the right side of figure 7.3, indicating a higher price compared to the aluminium and stainless steel alloys. Therefore, titanium is excluded to act as a material for developing a low-cost external fixator clamp.

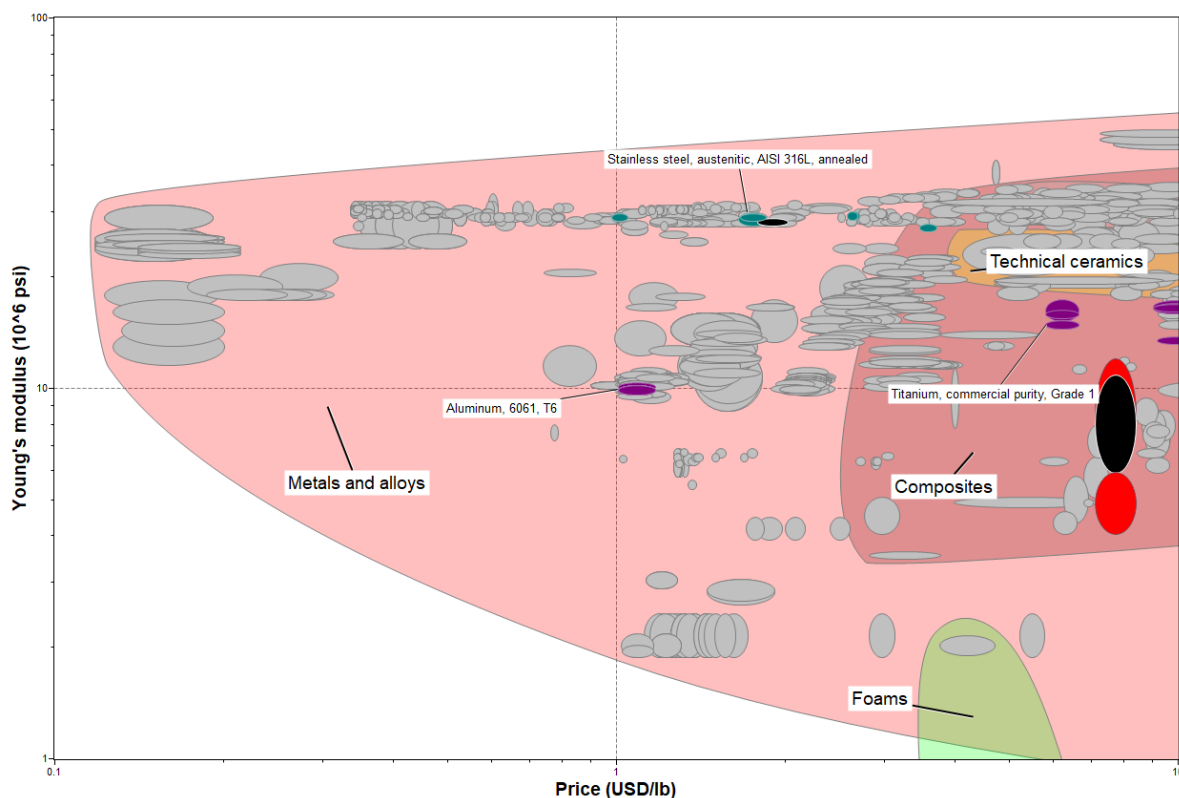

Figure 7.3: Young's Modulus (10⁶ *psi*) vs. Price (*USD/lb*) of the included materials ($n = 41$) in the EduPack analysis. Grey materials are excluded from the analysis as a result of the set limitations.

In figure 7.4, the density and YM of the remaining 17 metals is shown. The density of the remaining aluminium alloys is 0.0973 – 0.0987 *lb/in³* compared to 0.273 – 0.292 *lb/in³* of the stainless steel alloys.

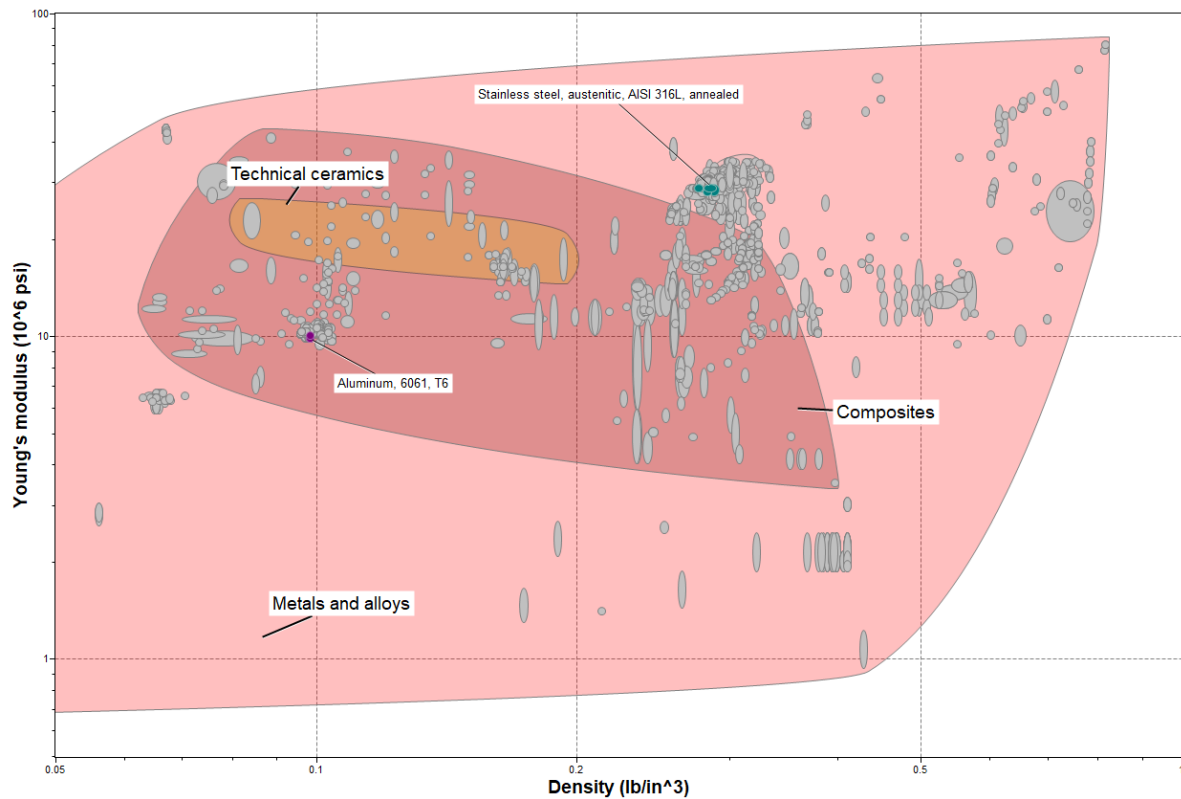

Figure 7.4: Young's Modulus (10^6 psi) vs. Density (lb/in^3) of the included materials ($n = 17$) in the EduPack analysis. Grey materials are excluded from the analysis as a result of the set limitations.

In the design process a trade-off has to be made between the stiffness provided by the clamp, an increase of weight, and the related costs. To substantiate this design choice, figure 7.5 provides an insight in the involved material properties. In this figure the YM divided by the density is displayed on the y-axis, and the price is presented on the x-axis. This figure implicates that the strength-to-weight ratio of the aluminium alloys is comparable with that of the stainless steel alloys. In terms of the price, do the aluminium alloys perform substantially better compared to the stainless steel alloys. Considering the substantially lower density supplemented with the lower cost per pound, generate apparently attractive properties for this application. On the other hand this is at the expense of the YM of the material. Less stiffness is provided to the clamp when opting for aluminium alloys.

To determine the most favorable material for the manufacturing of the clamp for LMICs, other relevant properties should be considered. One of them is the corrosion resistance, defined as the degree to which a metal can withstand damage as a result of oxidation or other chemical reactions [79]. Different types of corrosion might occur in metals, such as pitting corrosion, stress corrosion cracking, and intergranular corrosion. For stainless steel alloys, pitting corrosion is measured by the Pitting Resistance Equivalent Number (PREN). This is an estimation based on the alloy's chemical composition, which correlates good with the critical pitting temperature [3]. The stainless steel grade 316L, represented in the results of the material analysis, has a PREN of 22.6 – 27.9 and falls in the medium category. Furthermore, stainless steel 316L is slightly susceptible to stress corrosion cracking. In the results of the material analysis the 6000 series of aluminium is presented, especially aluminium 6061. This aluminium grade is an alloy comprised of magnesium (1.0%) and silicon (0.6%), which make it highly resistant to corrosion, stress and cracking [62].

In this phase of the research, to develop a prototype that is a step towards an external fixator clamp for LMICs, the manufacturability is of great influence. Therefore, the ease of production has to be taken into consideration given that the working principle must be demonstrated. The properties of aluminium 6061 features good formability, weldability, and machinability. This has a positive effect on production

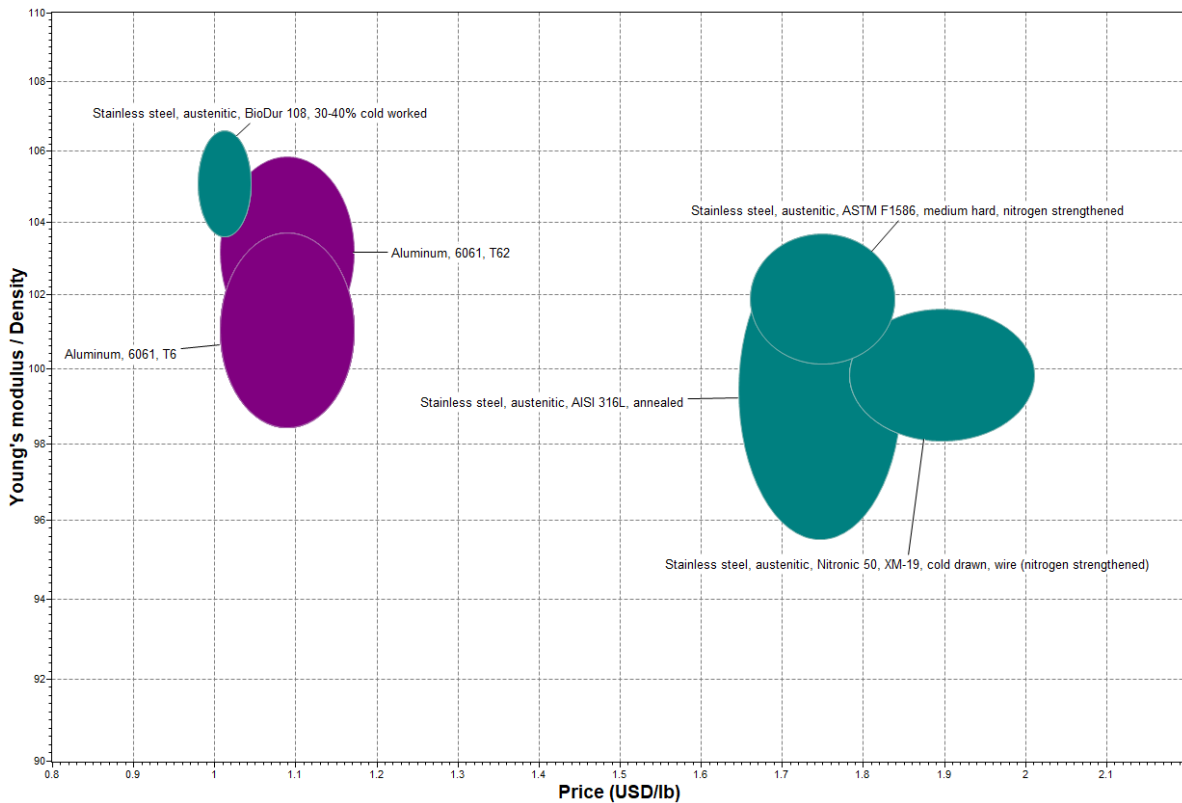
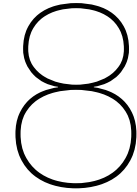

Figure 7.5: Young's Modulus (10^6 psi) divided by Density (lb/in^3) vs. Price (USD/lb) of the included materials ($n = 17$) in the EduPack analysis.

time, production costs, and ease of manufacturing. Stainless steel is considered as a more difficult material to machine in comparison with aluminium, because of the higher ultimate tensile strength and higher melting point.

Another type of stainless steel shown in figure 7.5 is Biodur 108. This alloy type uses manganese and nitrogen instead of nickel, and is developed as a result of concerns regarding adverse patient responses to nickel [60]. It is considered as one of the highest-strength tooling alloys on the market and is totally non-magnetic. This has a negative impact on the manufacturability of the prototype.

For these reasons, at this stage of the research it is decided to use aluminium 6061 for the fabrication of the external fixator clamp prototype. Working on the development of a prototype, the costs play a decisive role and are considered as the most important factor at this stage. It possesses a high strength-to-weight ratio, is sufficiently available in LMICs, and enjoys high manufacturability easing the development of the prototype. It is expected that aluminium 6061 provides sufficient strength for this application. However, if the results of the mechanical analysis differ significantly, in the next phase of development the choice of materials should be reconsidered and can be opted for a material with a higher strength. In further research, the consequences of repeated loading of the clamp prototype should be studied and based on this, a well-considered choice should be made for the use of materials.



Theoretical Analysis

8.1. Finite Element Analysis

The main function of the external fixator is to provide stability to the open fracture in order to optimize the healing process of the patient. Stabilization is provided to the open fracture by the placement of pins in the proximal and distal fragments. The clamps used to connect these pins to the external fixator system experience forces and moments in response to the fixation of the components and exerted forces by the patient. To understand the load transfer process in the concept clamp a Finite Element Analysis (FEA) is performed. Chao *et al.* states that the finite element method can be used to calculate frame rigidities for uniplanar fixation systems [14]. Therefore, to evaluate the mechanical behavior of the clamp concept, two FEAs are performed using SolidWorks 2019. The components are selected from the developed concepts and assembled in a simulation study.

In order to validate the performance of the universal clamp concept, it is subjected to two use cases. The first use case analyzes the forces the clamp experiences during definite fixation of a 8mm connecting bar, required to perform a stable external fixation. In the second use case, the effect of weightbearing on the universal clamp concept is simulated. The objective is to examine the distribution of the forces in the external fixator assembly, and thereafter inspect the effect on the individual universal clamp concept.

8.1.1. The interaction between screw and upper component

In the first FEA, the definitive fixation of a 8mm connecting bar in the clamp was examined. In this simulation the upper component of the clamp is compressed by the head of the M8 screw, resulting in the clamping of the connecting bar between the upper component and the friction disk.

In the pre-processing phase of the FEA, a 3D model of a simplified clamp is represented. The clamp consists of multiple components including two friction disks, an upper component, a lower component, and a M8 screw. In this simulation only half of the clamp is modeled i.e. the upper component and one friction disk. This geometry allows to study the effect of clamping the 8mm connecting bar between the upper component and friction disk.

The materials used in this simulation are the selected materials from the material analysis in section 7. Aluminium 6061 is assigned to the upper component and friction disk. Stainless steel AISI 316 is selected for the connecting bar.

In the next step the contact sets are assigned, describing the interactions between the solid components. The first contact set is between the connecting bar and the four planes of the 8mm diameter part of the upper component. The second contact set is between the connecting bar and the friction disk. The third contact set is between the plane of the upper component and the friction disk, to prevent penetration between these components.

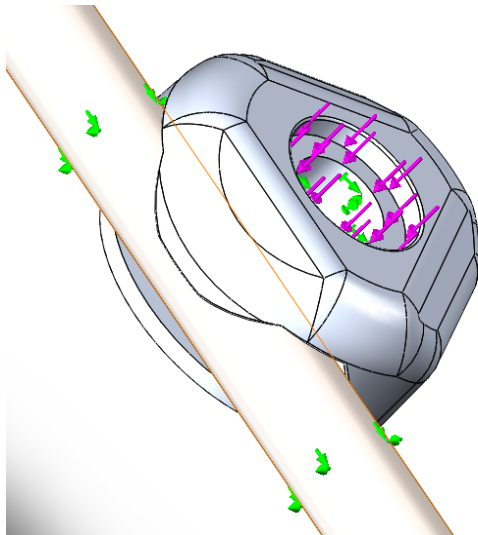

Figure 8.1: Top view of the simulated clamp concept. Overview of the fixtures and loads on the included components.

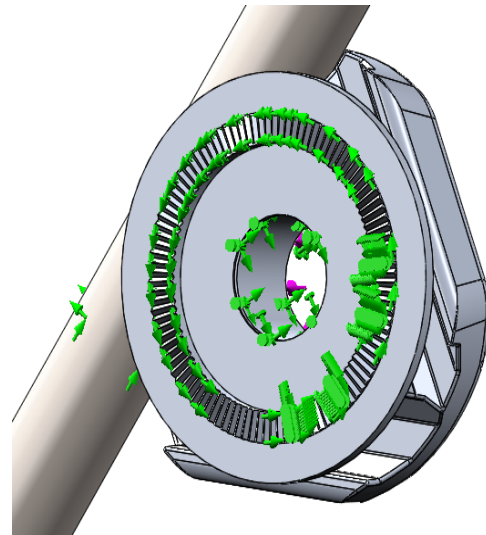

Figure 8.2: Bottom view of the simulated clamp concept. Overview of the fixtures and loads on the included components.

Thereafter, the fixtures and loads of the simulation are determined. Figure 8.1 shows the top view of the components. The bottom view of the components is displayed in figure 8.2. In order to restrict rotational movement, the cylindrical planes of the upper component and friction disk are fixated. Also, the upper component and friction disk are allowed to move in the y-direction. Movement on the x-axis and z-axis is restricted by adding fixtures on the components. Fixtures on the connecting bar and upper component of the clamp prevent movement during the simulation in the x-direction and z-direction. Movement in the y-direction is allowed for these components. A quarter of the friction disk is fully fixated, assuming that this component interacts with the other friction disk when assembled. In order to describe a worst-case scenario, it is decided not to fix half, but a quarter of the friction disk. A loading of 5000N is applied where the screw connects with the upper clamp. The clamp will not be subjected to these improbable conditions, but it allows to examine both the performance of the material and the vulnerable regions of the clamp. In this simulation a curvature-based mesh is used with a maximum element size of 4.13mm and a minimum element size of 0.83mm . The minimal number of elements in a circle is 8, and the element size growth ratio is 1.6.

The results of this simulation are shown in figure 8.3, 8.4, 8.5 and 8.6. Figure 8.3 and 8.4 show the displacement results expressed in mm. As a result of the exerted load, the maximum displacement is $2.524e - 03\text{mm}$ and is located on the connecting surface of the upper clamp with the screw. Figure 8.5 and 8.6 show the stress that results from the applied loads. The biggest magnitude of the stress value is $1.525e8\text{ N/m}^2$ which is located at the inner edge of the screw compartment.

In this SolidWorks model, the friction disk is simplified using a smooth surface instead of the friction structure. This is deliberately done to ensure that the contact sets are distributed proportionally. This is the first assumption that is made and is considered valid because of the equal thickness of the friction disk in the clamp and the simulation model. Also, half of the clamp is simulated in this simplified analysis. It is expected that this has minimal effect on the outcomes, as the two friction disks are fixated relative to each other. This results in restricted rotation and limited axial movement.

In this study, the results are presented of the effect of definitive fixation on the clamp concept. The results show that the largest stress is experienced during the definitive fixation of the 8mm connecting bar at the inner circular contact edge between the screw and the upper component. Additionally, the impact on the edge of the friction disk should be taken into account. With a relative high displacement of $1.893e - 03\text{mm}$, it can be considered as a vulnerable structure of the clamp concept. Definitive fixation generates significant stress in the upper component of the clamp, but the results are promising with respect to material consideration and clamp design. The chosen material, aluminium 6061, shows

promising performance results. Additional mechanical testing of the clamp should be considered to support these findings.

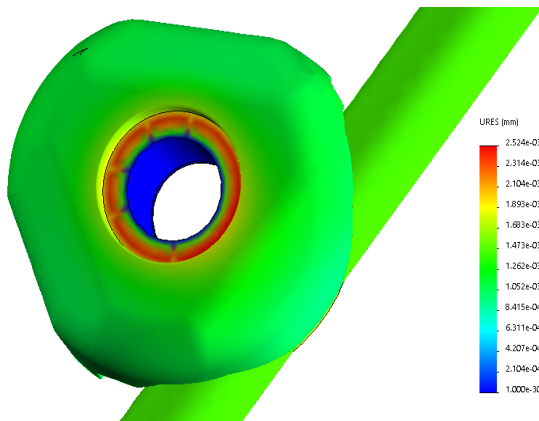

Figure 8.3: Overview of the displacement (mm) in the clamp as a result of the applied force on the simulated clamp concept. Top view.

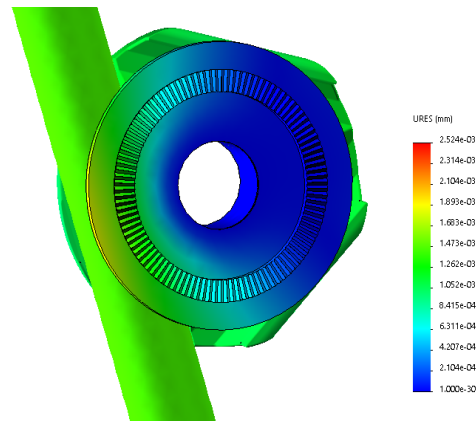

Figure 8.4: Overview of the displacement (mm) in the clamp as a result of the applied force on the simulated clamp concept. Bottom view.

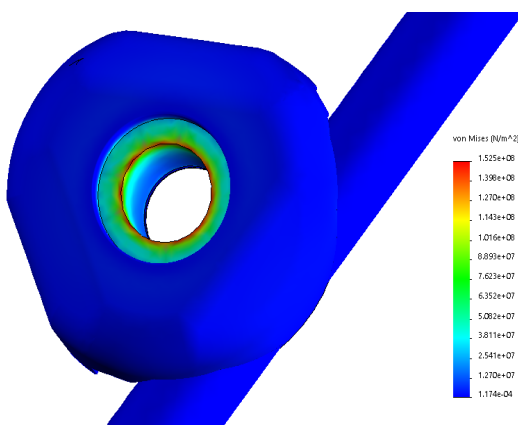

Figure 8.5: Overview of the Von Mises (N/m^2) in the clamp as a result of the applied force on the simulated clamp concept. Top view.

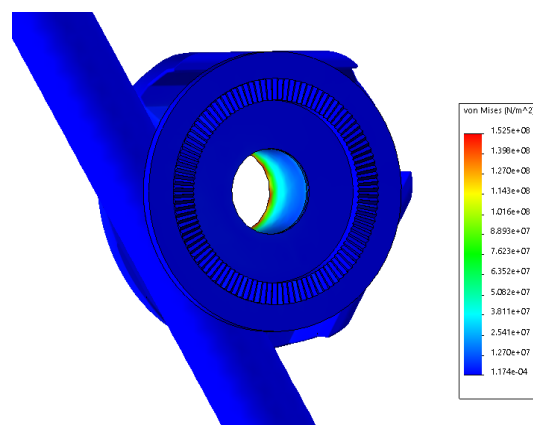

Figure 8.6: Overview of the Von Mises (N/m^2) in the clamp as a result of the applied force on the simulated clamp concept. Bottom view.

8.1.2. The effect of tibial weightbearing on the clamp concept

During post-operative treatment periods, many patients are weightbearing with an external fixator as tolerated by the treating physician [37]. Weightbearing results in compressive loading in the axial direction and micro-movements at the fracture site, which have a beneficial effect on bone healing [47]. Poor stability of the external fixator may cause excessive interfragmentary movements during weightbearing, leading to a prolonged healing period and lead to delayed union or nonunion of the bone fragments [45].

Acting as a mechanical bridge, the external fixator is responsible for the load transfer through the fractured bone. Failure properties in relation to weightbearing should be accounted for when developing an external fixator. Therefore, the effect of weightbearing on the clamp concept of the external fixator clamp is investigated.

A simplified 3D model of the clamp is used in the pre-processing phase of the FEA to simulate the pin-clamp interaction. In this model the effect of weightbearing during gait on the tibial bone is simulated. The simulation is based on a male patient, suffering from a tibial open fracture, 45 years old,

weighing $100kg$, and having a length of $185cm$. The effects of normal gait, as prescribed by the treating physician, on the clamp is evaluated.

In most conditions, the guideline to treat lower limb open fractures of adults is by opting for $5mm$ pins [28]. Therefore, the geometry of the analysis consists of a $5mm$ pin gripped by the upper component and one friction disk. The clamp is horizontal aligned with respect to the tibial bone. The distance between the clamp component and the tip of the $5mm$ pin has to be minimized, in order to enhance frame stability [29]. In previous research, Zhao *et al.* studied the load transfer process between an external fixator and a bone model, implementing a clamp bone distance of $45mm$ [80]. Therefore, the distance between the upper clamp component and the tip of the $5mm$ pin is set at $45mm$. The materials used are the selected materials from the material analysis in section 7. The upper component and friction disk are manufactured from aluminium 6061-T6, the $5mm$ pin from stainless steel AISI 316.

The contact sets are assigned in the next step. The interactions between these solid components consists of the pin interaction with the four planes of the $5mm$ diameter part of the upper component. Also, the pin forms a contact set with the friction disk. In this simulation the $5mm$ pin is divided into two parts, in order to apply the forces at the desired location. Therefore, a self-contact interaction is applied between the two parts of the pin.

In the next step, the fixtures and loads are assigned. In figure 8.7, the top view of the boundary conditions are shown. Figure 8.8 displays the bottom view of the assigned conditions. The rotational movement of the upper component and the friction plate is restricted by assigning fixation in the cylindrical planes. Furthermore, movement in the x-axis and z-axis is restricted by adding fixtures on the cylindrical planes of the aforementioned components. The flipside of the upper component, with respect to the area that clamps the $5mm$ pin, is fully fixated in all directions. Also, half of the friction disk is fully constrained in all directions. These fixed geometries, simulate the interaction with the screw component and the second friction plate, respectively. The $5mm$ pin was fixated in the x-axis and z-axis.

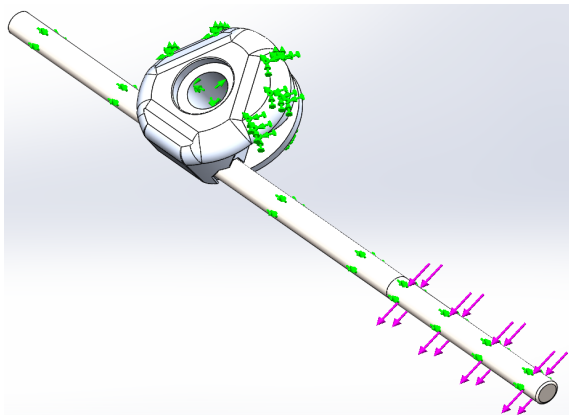

Figure 8.7: Top view of the fixtures and loads applied on the components of the simulated clamp concept during weight-bearing.

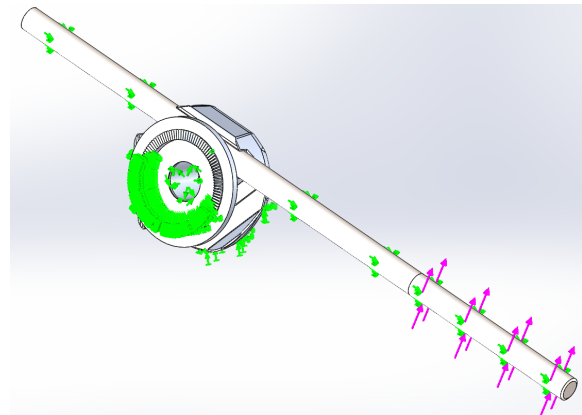

Figure 8.8: Bottom view of the fixtures and loads applied on the components of the simulated clamp concept during weight-bearing.

In this analysis it is assumed that the patient suffers a complete lesion, where the weightbearing is completely transferred to the external fixator and part of the weightbearing is not absorbed by the bone itself. A load is applied on the area of the pin that was implanted in the tibial bone fragment. Wehner *et al.* state that muscle contractions combined with the ground reaction force (GRF) lead to a high internal force in the axial direction of the tibial bone part during gait with a maximum of 4.7 times body weight (BW) [75]. Therefore, a load of $4609N$ is applied in this model, simulating the force expressed on the tibial bone during normal gait of this patient. This axial loading is applied on the y-axis, as shown in figure 8.7 and 8.8. A curvature-based mesh is used with a maximum element size of $3.92mm$ and a minimum element size of $0.78mm$. The minimal number of elements in a circle is 8, and the element

size growth ratio is 1.6.

In figure 8.9, 8.10, 8.11 and 8.12, the results of the tibial weightbearing simulation on the clamp are shown. The displacement results, expressed in mm, are shown in figure 8.9 and 8.10. The maximum displacement is $3.112e - 01mm$ and is located on the tip of the 5mm pin. In figure 8.11 and 8.12 the resultant stress of the applied load is shown. The maximum stress value is $7.872e8 N/m^2$ and is located at the inner diagonal contact set between the upper component and the 5mm pin.

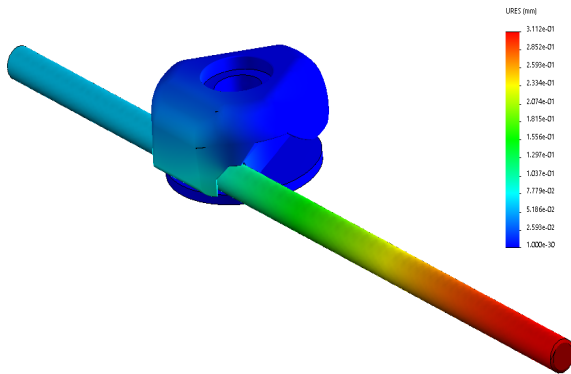

Figure 8.9: Overview of the displacement (mm) as a result of weightbearing on the simulated clamp concept. Top view.

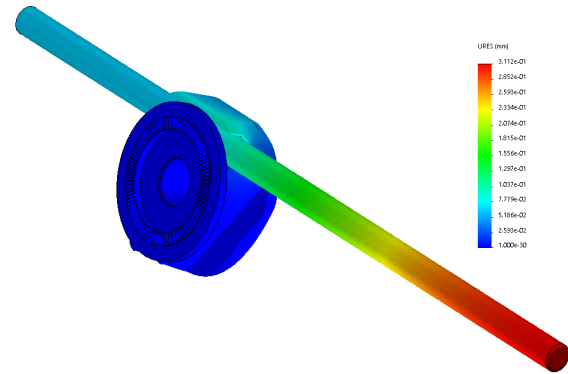

Figure 8.10: Overview of the displacement (mm) as a result of weightbearing on the simulated clamp concept. Bottom view.

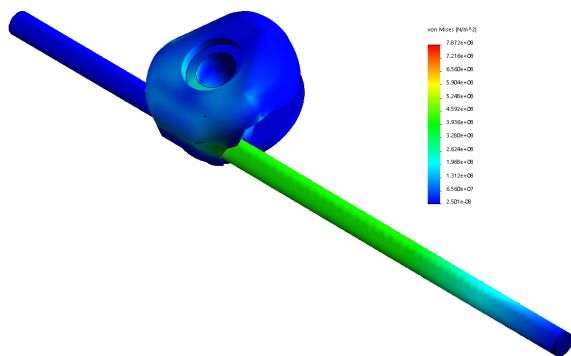

Figure 8.11: Overview of the Von Mises (N/m^2) as a result of weightbearing on the simulated clamp concept. Top view.

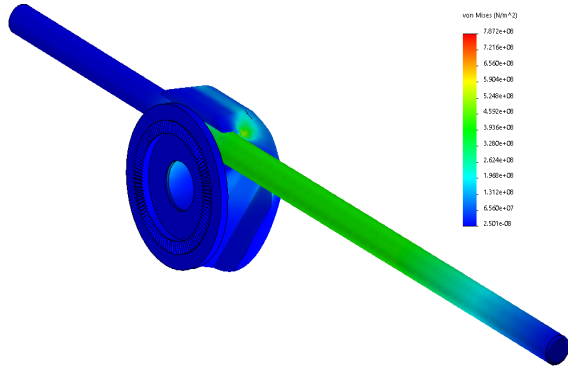

Figure 8.12: Overview of the Von Mises (N/m^2) as a result of weightbearing on the simulated clamp concept. Bottom view.

Because the effect of weightbearing on the upper clamp component wants to be examined, focused is on this component in figure 8.13 and 8.14. The exerted stress as a consequence of weightbearing results in the displacement and stress as indicated in these figures. The maximum displacement is $9.483e - 02mm$ and is located at the tip of the 5mm-housing. Regarding the maximum stress value, this is found at the inner edge of the 5mm-housing of the upper clamp component. The maximum Von Mises stress has a value of $7.936e8 N/m^2$.

This SolidWorks model describes the effect of tibial weightbearing in the axial direction on the clamp concept. These results are obtained using a simplified model of the clamp. In this simplified model the friction disk is simulated with a smooth surface instead of the friction structure. In order to distribute the contact sets proportionally, this is done purposely. The second assumption in this model is the amount of force simulated during weightbearing of the patient. In this study it is assumed that the full tibial weightbearing load is distributed over one pin. This is in contradiction with the actual load distribution in the external fixator, as four pins are placed in the tibial bone and endure this total load. Therefore, excessive results are obtained in this study due to this assumption. On the other hand, the aim of the FEA is to visualize the effect of weightbearing on the clamp and understand its mechanical behavior.

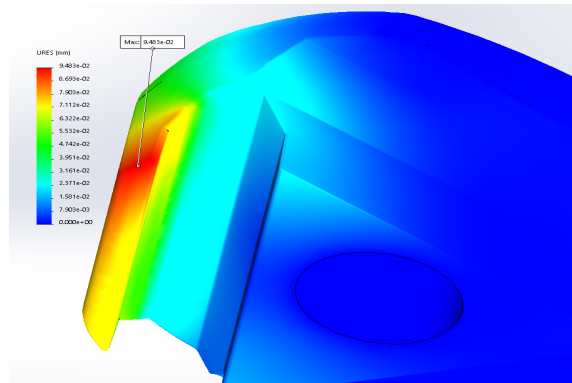

Figure 8.13: Overview of the displacement(mm) as a result of weightbearing on the simulated clamp concept. Focused on the area of maximum induced displacement at the upper component of the universal clamp concept.

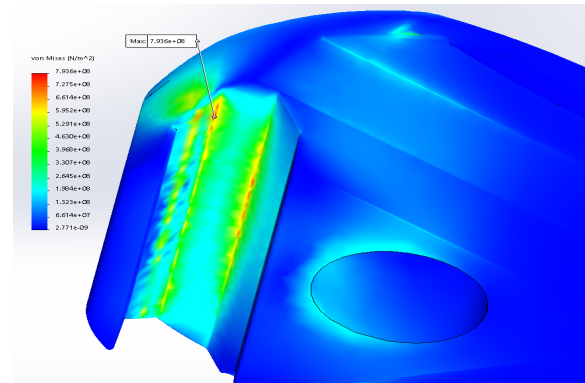

Figure 8.14: Overview of the Von Mises (N/m^2) as a result of weightbearing on the simulated clamp concept. Focused on the area of maximum induced stress at the upper component of the universal clamp concept.

The results of the analysis present the vulnerable structures of the clamp during weightbearing. The largest deformation is $3.112e - 01mm$ and is located at the pin area of the applied force. The applied force generate significant stress in the upper component of the clamp, but do not lead to concerns. This simulation suggests that the use of materials and clamp design function desirably for this application. Further examination in the form of mechanical testing should be performed in order to support these findings.

8.2. Bolt analysis

The conceptualization process results in a concept design of the prototype external fixator clamp, which meets the requirements and desires for application in LMICs. The most suitable material for this application is selected based on their mechanical properties and the design requirements of the prototype. The performed FEA demonstrates that the design of the clamp in combination with the used material would withstand the forces that it experiences in the interaction with the screw and during weightbearing. Although it is suggested, based on the calculations, that the prototype clamp in this stage of the design process is ready to be manufactured, a final characteristic must be considered. The amount of threading in the lower component of the clamp, determines the amount of force that can be applied on the screw before the clamp component or the screw fails. Therefore, sufficient threading should be implemented in the lower clamp component to withstand the experienced forces on the one hand, while considering the effect on the total size of the clamp on the other hand. When this aspect is considered, the final dimensions of the clamp prototype will be determined.

For the evaluation of the required threads in the compartment the minimum thread engagement is determined. Failure of the screw of the clamp is preferred over the threaded strips. Therefore, it is required that the shear area of the threaded screw is over two times the tensile area. The minimal thread engagement of the screw can be calculated with the following equation:

$$Le = \frac{2 * At}{0.5\pi(D - 0.64952 * p)} \quad (8.1)$$

A M8 bolt has the following properties; a tensile stress area (At) of $36.61mm^2$, a pitch (p) of $1.25mm$, and a major diameter (D) of $8mm$. The calculated minimal thread engagement is $6.4848mm$. Because there is difference in material between the clamp component and the screw, a thread engagement ratio has to be implemented. Using equation 8.2 the ratio can be calculated:

$$J = \frac{\text{Tensile strength of external thread material (screw)}}{\text{Tensile strength of internal thread material (hole)}} \quad (8.2)$$

The tensile strength for a M8 Grade 8.8 steel screw is $800MPa$ [58]. The determined tensile strength for

aluminium 6061 is 310MPa [5]. The calculated value for J is 2.5806. With the thread engagement ratio and the minimal thread engagement value, the adjusted minimal thread engagement can be computed using the following formula:

$$Le_{adj} = Le * J \quad (8.3)$$

The calculated value for Le_{adj} , using equation 8.2, is 16.7349mm . This value represent what the required thread length should be in order to avoid plastic deformation and failure of the screw. However, the torque required to fasten the bolt to the clamp is 7.5 N-m according to previous research [30]. With this indication the desired bolt tension can be determined with the following equation:

$$F = \frac{T}{c * D} \quad (8.4)$$

In this equation c is the coefficient of friction constant, which is equal to 0.61 in static condition. The nominal bolt diameter, 8mm , is defined by D. The torque required is specified with T and has in this function a value of 7.5 N-m . The axial bolt clamp force (F) calculated with equation 8.2 is 1536.8N .

The maximum torque for a M8 8.8 grade bolt is equal to 25.28 N-m [53]. When this value is put into equation 8.2, this results in a total maximum axial bolt clamp force (F) of 5180.3N . The ratio between the maximum axial bolt clamp force and the 7.5 N-m axial force is equal to 3.37. This implicates that the force that has to be endured by the threaded lower compartment of the clamp as a result of fastening of the screw is significantly lower. The required thread engagement length of the lower component is expected to be less than the previously calculated 16.7349mm . In the design of the prototype clamp is chosen for a threaded length of 12mm , to minimize the size of the clamp and the associated weight, and in accordance with the rule of thumb to apply a thread length of 1 – 1.5 times the diameter of the screw [22].

In conclusion, the used thread engagement length of the lower component of the clamp concept is expected to be sufficient for this application.

9

Final Clamp Design

By implementing the thickness into the design of the clamp prototype, the final design is obtained. This developed clamp concept is designed based on the preset requirements for application in LMICs, and throughout the iterative design process these are taken into account.

In comparison with the three-way-clamp the final concept is improved in terms of stability enhancement, weight limitation, and an increase in functionality. A rendering is shown of the final clamp concept in figure 9.1.

This universal clamp is able to provide both pin-bar as bar-bar fixation by the implementation of the three different diameters in both fastening components, and therefore reduces the number of required components to treat open fractures. The friction disks increases the friction between the clamp and the pin or connecting bar, and a snap-in system is provided in between the two friction disks. The material selected for this application is aluminium 6061. The material usage in combination with the practiced design alterations brings the total weight of the clamp on $46g$, including the screw and end nut component.

As a result of the screw component is the total length of the clamp $55mm$. By rounding of the lower $14mm$ of the screw, sterilization of the clamp is enhanced as this becomes a compartment for the lower clamp component.

To examine the performance of the final clamp design, the next step in the thesis process is to consider different manufacturing methods. Subsequently, manufacturing companies affiliated with the desired demand are looked for and the fabrication process is set in motion. When the final prototype is designed its mechanical performance can be analyzed in a comparison with an accepted external fixator clamp in modern hospitals.

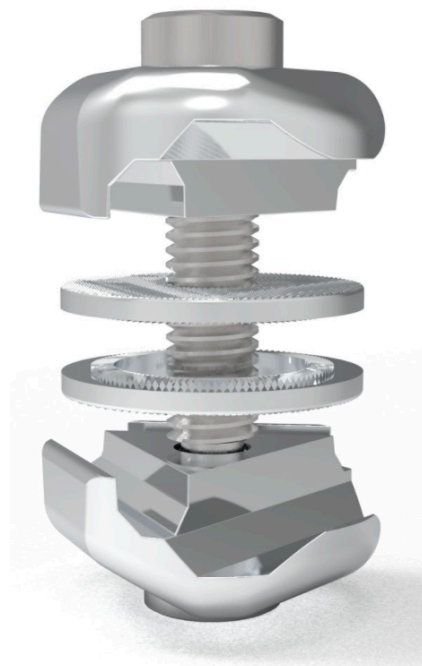

Figure 9.1: Rendering of the final external fixator clamp concept.

10

Prototype manufacturing

10.1. Manufacturing methods

In order to evaluate the final clamp design, the next phase in the development process is to examine the manufacturing techniques. This is performed based on the characteristics of the final design and the derived use of materials from the material analysis. In addition, the goal of the project is evidently taken into account in choosing a production method. To develop an external fixator clamp for application in LMICs requires to limit the costs of the manufacturing process, as this is a crucial factor for the external fixator set to be successfully adopted in LMICs. Furthermore, limited financial support is available for this graduation project, which therefore relates with the design goal to develop a low-cost external fixator for LMICs.

Another factor that is taken into account in choosing a production method is the production time of the clamp. Since fabrication is an element of this research, the associated importance has to be taken into account. The scope of the project is to demonstrate a proof of concept by manufacturing the clamp design, within the time frame of the graduation project. Therefore, it is required that the production time is in proportion with the overall project time.

In consultation with experts from the biomaterials and tissue engineering department, and biomechanical engineering department of the TU Delft different manufacturing methods are evaluated and considered. These can be divided into two categories: 3D printing and CNC machining.

10.1.1. 3D printing

In a wide range of healthcare settings, including orthopaedic surgery, metal 3D printing is used more and more. 3D printing is based on the model of additive manufacturing, in which layer by layer of raw material is added to the object in a predetermined manner. The main direct applications of this technology are to personalize treatment and preoperative planning, customize surgical tools and equipment, and the fabrication of tissue engineering scaffolds [19][2][77]. In the development of external fixators, this manufacturing technique is also practiced [59]. In this research however, the external fixator frame is made of photosensitive resin and manufactured by 3D printing technology.

In case of metal 3D printing for biomedical applications, a broad variety of techniques can be selected. Commonly used 3D printing techniques for almost all metal alloys are selective laser melting (SLM), laser direct metal deposition (LDMD), and selective electron beam melting (SEBM).

The SLM process, shown in figure 10.1, uses high-energy fiber lasers to fuse metal powder together. A reservoir below or aside the powder bed provides new metal supply after each fabrication layer. New layers of metal powder are spread over the previous layer by a roller or a blade, and a more evenly distribution of the powder is often encouraged by vibration. An inert gas is required in this 3D printing technique to prevent the metal from reacting with other gases at high temperatures. SLM is considered

as a fast technique, but is characterized by a poor energy efficiency of 10% to 20% resulting in high energy costs [52].

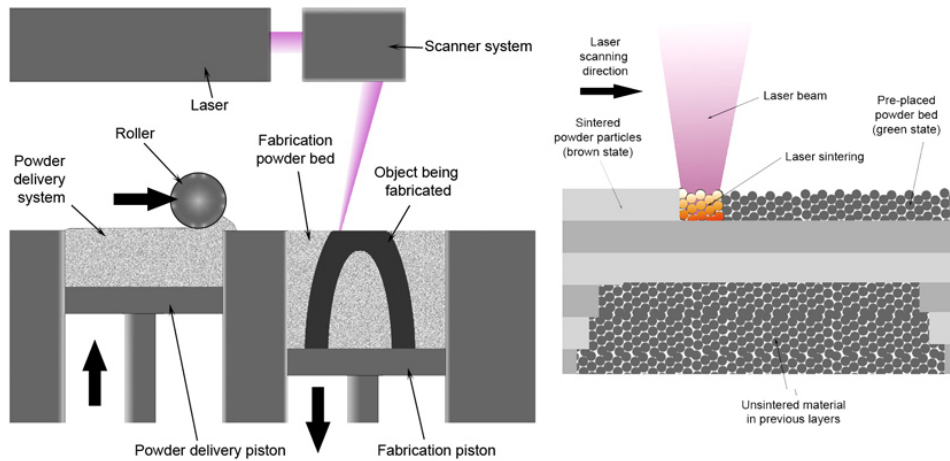

Figure 10.1: Schematic diagram of components involved in selective laser melting (SLM) process[35].

The process of LDMD, shown in figure 10.2, is based on the principle to combine a centralized laser beam with a nozzle that aggregates powder on its working plane. This metal powder is guided by a carrier gas and is released on a workpiece. The laser beam solidifies the powder which is delivered through a nozzle, creating a melting pool at that position. The benefits of applying this 3D printing technique is its ability to create large volume parts and combine different kind of metals in its nozzle to produce specific metal alloys.

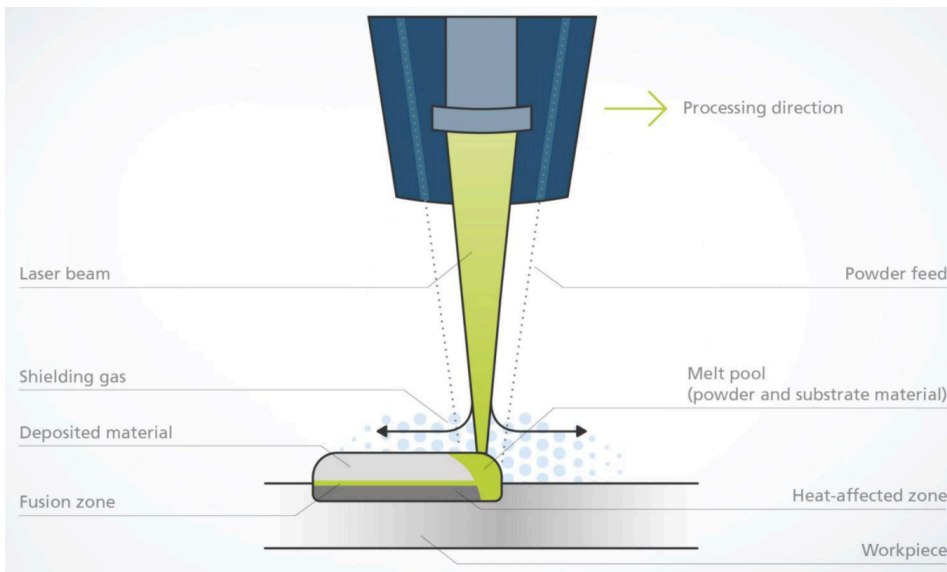

Figure 10.2: Schematic diagram of components involved in laser direct metal deposition (LDMD) process[72].

In figure 10.3, a schematic drawing is presented of the SEBM process. This rapid manufacturing technique uses high-energy electrons moving at high speeds to accurately melt metal powder. This method allows to additive manufacture metallic components with a complex shape. The first step in this process is the spread of metallic powder on the build table. Then the electron beam selectively melts layer-by-layer according to the 3D CAD model put into the computer. This procedure takes place in a vacuum chamber until the part is completed. The excessive powder is removed in the post-processing phase of manufacturing to obtain the desired 3D metal part.

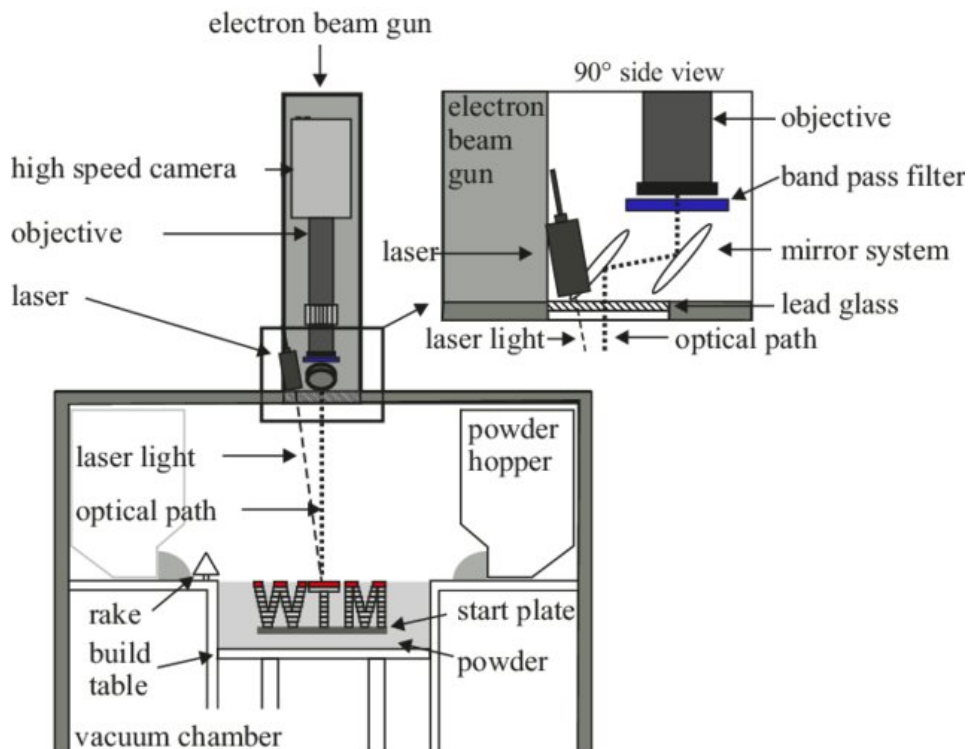

Figure 10.3: Schematic diagram of components involved in selective electron beam melting (SEBM) process[61].

However, 3D printing processes involving melting are impossible to use for 6061 aluminium alloy. Because of the large temperature gap between the solidus and liquids, this leads to cracking of the object when manufactured. Therefore, the aluminium alloys that allow 3D printing techniques where melting is involved always have compositions close to the eutectic composition, for example AlSi10Mg.

Nonetheless, alternative 3D printing techniques are available that allow printing at room temperature or a moderately elevated temperature. In this case, a mixture of aluminium powder with another material, such as a thermoplastic, is used in the form of a wire, filaments or granules. After the 3D printing process, it is required to remove the plastic during post processing of the object. In order to achieve a density close to the theoretical density of aluminium 6061 alloy, debinding and sintering is required. Finally, the T6 heat treatment will be performed and has to be evaluated if the mechanical properties correspond with those specified of aluminium 6061 alloy.

10.1.2. CNC machining

One of the most popular manufacturing processes for aluminium alloys is computer-numerical-control machining, in short CNC machining. In this manufacturing process pre-programmed computer software commands the movement of factory tools and machinery. Complex machinery can be instructed to perform three-dimensional cutting tasks in a single set of commands. Instead of manual control, where live operators are required to invoke and control editing tool commands via levers, buttons and wheels, the CNC process runs through programmed software. The language behind CNC machining is referred

to as G-code, a numerical control software program to control a machine. For instance, the speed, feed rate and coordination can be assigned, which makes it consistent to program and flexible to develop different parts.

G-code is a straightforward, logical way to control a CNC machine. In the code a "G" is followed by a number, which changes the geometry of the machine [67]. The code "G00" stands for rapid movement, and "G01" is a command that represents linear feed move. "G02" produces a clockwise and "G03" a counterclockwise movement. This code is followed by a geometric location, where coordinates on the x- and y-axis transfer the movement of the CNC machine, as shown in figure 10.4. For example, the code "G00G58X-80.Y20." can be broken down in different parts. The first part "G00" stands for rapid move. "G58" indicates the work coordinates, a translation in geometry with respect to the work offset. The next part of code specifies this changing geometry, with "X-80" indicating a displacement of -80mm on the x-axis and "Y20" a translation of 20mm on the y-axis.

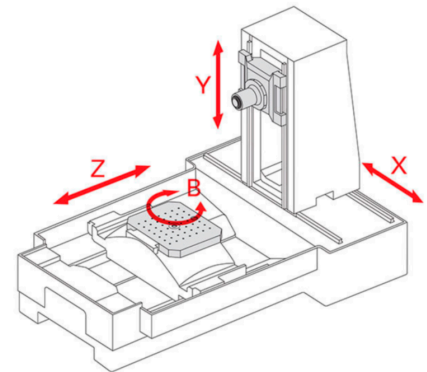

Figure 10.4: Schematic drawing of CNC machine, describing the axis of the CNC spindle to perform a cut or other function [67].

CNC machining is very applicable for aluminium alloys, as it is a strong material and possesses an oxidized layer which makes it resistant to corrosion from the elements. In addition, aluminium offers good machinability because of the easy removal of material. Therefore, aluminium is easy to shape and can be cut with high accuracy. The machining of aluminium is more than three times faster in comparison with iron or steel, which shortens the manufacturing time and results in lower production costs [1]. Another consequence of the good machinability of aluminium is that lower tolerances can be met, leading to higher accuracy and repeatability. This is a result of less deformation of the object taking place when the cutting tool of the CNC machine penetrates the aluminium.

10.2. Manufacturing of the prototype

After evaluation of the different manufacturing processes, in consultation with the different experts of the TU Delft, available companies are looked at that master one of these techniques. Eventually, it is decided to opt for a company that is able to CNC machine the final design of the clamp prototype. Various companies in The Netherlands and abroad are approached by mail and telephone. Using existing contacts within the TU Delft and after hearing positive experiences about the company, it is ultimately chosen to work together with *Tosony B.V.*, which is based in Hong Kong. The clamp design can be produced and delivered to The Netherlands on the short term, despite the developments surrounding the COVID-19 pandemic, at relatively low costs.

In accordance with the necessary equipment for mechanical analysis, a total of four clamps are produced, manufactured from aluminium 6061. In an agreement with both parties, it is decided that *Tosony B.V.* manufactures four clamps, consisting of four upper components, four lower components, and eight friction disks. These components are delivered to The Netherlands within 18-20 workdays, and the rest of the components required for the assembly of the clamp are arranged by the researcher.

When the order request is received by the company, the production process could be set in motion. Firstly, the CAD models and associated technical drawings are transferred to *Tosony B.V.*, to facilitate the drawing process of the local engineers. The technical drawings of the clamp prototype are provided in Appendix F. The manufacturing company uses CNC machining techniques to produce the clamps. Based on the provided technical drawings the engineers of *Tosony B.V.* write a G-code to control the CNC machine tools to produce the parts. For this process they use a CNC turning lathe and a five-axis CNC milling machine, shown in figure 10.5 and 10.6. A tolerance of 0.1mm is used by the manufacturers. After the clamps come off the working bench of the CNC machine, they are post-processed and finalized to then be shipped to The Netherlands. Within 20 working days, the four clamps arrive at their destination so they can be collected and observed by the researcher.



Figure 10.5: The CNC turning lathe (Japan Fanuc) used by *Tosony B.V.* for manufacturing of the four external fixator clamp prototypes.



Figure 10.6: The five-axis CNC milling machine (Japan Fanuc) used by *Tosony B.V.* to manufacture four of the external fixator clamp prototypes.

The components are supplemented with hexagon socket head cap M8 screws of 50mm and stainless steel disc springs with an outer diameter of 16mm. The final prototype clamp is shown in figure 10.7. The appearance and characteristics of the prototype met the expectations of the researcher, but the performance of the clamp was questioned. Therefore, in the next phase of the research the clamp was mechanically compared with a recognized external fixator clamp, the Hoffmann 3 clamp developed by *Stryker Corp.* The Hoffmann system is an accepted external fixation system in modern hospitals, and demonstrates high performance and ease of use. In figure 10.7, a tibial open fracture model is treated with a hybrid unilateral external fixation system, assembled from three prototype clamps and three Hoffmann 3 clamps.



Figure 10.7: On the left, the universal clamp prototype. On the right a tibial open fracture model treated with a hybrid external fixation, consisting of three universal clamps and three Hoffmann 3 clamps.

1 1

Mechanical Testing

In order to examine the performance of the manufactured universal clamp prototype, it is mechanically compared in the next phase of the project. To test the stability the clamp provides, it is subjected to two mechanical tests: rotational- and slippage testing. These test are performed with 4mm-, and 5mm fixator pins, and 8mm-connecting bars. It is compared with the Hoffmann 3, a state-of-the-art clamp which is currently adopted in modern hospitals.

In the first step of the mechanical analysis, a fixture is manufactured providing fixation to both type of clamps for all tests. It is manufactured from aluminium 7071 and CNC produced at the TU Delft. The fixture is shown in figure Appendix I. To determine the dimensions of the fixture, SolidWorks 2019 is used to place the universal clamp in the fixture and adjust the width, length and thickness. A hole is centered in the design of the fixture, after which the upright structures are then applied, based on the dimensions of the fixator pins and connecting bars fixed by the universal clamp.

Initially it is determined to subject the clamp to three different tests. However, due to a lack of appropriate equipment to perform the clamp-axis-pivot test, two tests are performed during this mechanical analysis. First, the rotational tests are performed for both clamp types by the researcher. Thereafter, the slippage tests are performed. Due to the COVID-19 pandemic, it is not possible to follow the training courses to control the linear actuator, so the tests have to be performed by experienced TU Delft Staff. In the presence of the researcher, Ing. M.A. Leeftang controls the linear actuator to execute the slippage tests.

Subsequently, an article is written about the study. This article, presented on the next page, contains the methods used to perform the mechanical tests and shows the outcomes that follow from this study.

Technical University of Delft (TU Delft)
doi: 10.1017/pas.2020.xxx.

Mechanical evaluation of an external fixator clamp prototype applicable for low-resource settings

Horsman, C.P.P.¹

¹ Master Biomedical Engineering, Technical University Delft

Abstract

Background: The treatment of open fractures in low-and middle income countries (LMICs) has been indicated as an important Bellwether procedure. A low-cost external fixator prototype clamp was developed, meeting the requirements of LMICs, and compared with an advanced Hoffmann 3 clamp.

Methods: Two types of external fixator clamps, the universal clamp and the Hoffmann 3 clamp, were compared with respect to six mechanical parameters. Rotational and slippage testing of the two types of clamps was performed using a specially designed fixture to mechanically test four clamps of each type at a clamp-bolt tightening torque of 4.4 N-m, 6.1 N-m, and 7.8 N-m. The slippage and rotation capacity of 4mm- and 5mm fixator pins and 8mm connecting bars was tested. A two-way repeated-measures ANOVA was used for the statistical analysis, adopting a p-value of 0.05.

Results: In all universal- and Hoffmann 4 clamps axial- and rotational slippage was observed for all parameters. The Hoffmann 3 clamps withstood significantly higher forces in comparison with the universal clamp for all conditions. Plastic deformation was observed at all friction disks of the universal clamp, in contrast to the Hoffmann 3 clamp where this was not identified.

Conclusion: Overall, the design of the universal clamp is promising as a prototype for application in LMICs. However, considering the plastic deformation observed and significant less performance in comparison with the Hoffmann 3 clamp, material usage and design alterations have to be considered to improve the mechanical performance of the clamp.

Clinical Relevance: The development of the universal fixator will improve open and neglected fracture treatment in LMICs, a growing global problem and consequently raises the need for trauma and emergency services. Providing stability to the open fracture is related to the resistance of motion within the clamp. Understanding this mechanical behavior of the clamp is essential to ensure rigid fixation in open fracture treatment.

Keywords: External fixator clamp – Mechanical analysis – LMICs – Open fracture treatment

INTRODUCTION

There exists an urgent need for surgical care in the world's poorest regions. With the absence of this care, easily treatable illnesses become diseases with high fatality rates and extensive complications. In total, 2 to 5 billion people have poor access to essential medical care (10). In low-income and middle-income countries (LMICs) nine out of ten people have no access to basic surgical care (7). With over a third of the world's population, only 6% of the total 313 million procedures worldwide occur in the poorest countries (8).

One of the key metrics indicated by the Lancet commission is access to a facility where the three Bellwether procedures are provided: laparotomy, caesarean delivery and treatment of open fractures. These procedures require skills that span general

and orthopedic surgery, obstetrics, and anaesthesia (9). All primary care hospitals should aim to provide these Bellwether procedures, because systematically facilitating these procedures suggests functional surgical systems with a versatile service delivery. One of these Bellwether procedures, open fracture treatments, are commonly presented in the hospital and can be caused by a simple fall or a serious accident. Correct and timely treatment of patients is important to reduce the infection risk and decrease morbidity rates (2). However, in first-level hospitals in LMICs only 40% of all open fractures are treated, which is supported by findings in country-specific studies (8).

The use of external fixation, one of the methods to treat open fractures, is a popular method to treat open fractures. To date different external fixator systems

are available on the market, varying in number of components, material usage, and costs. Limited research has been conducted on the development of an external fixator meeting the requirements of LMICs.

In this research a low-cost external fixator prototype clamp applicable for LMICs, the universal clamp, was mechanically compared with a Hoffmann 3 clamp. The universal clamp allows fixation of two pin diameters, 4mm and 5mm, and one connecting bar of 8mm. The Hoffmann 3 clamp was recognized as an advanced external fixator clamp and has been adopted in many hospitals. The two types of external fixator clamps were compared with respect to six different parameters of movement controlled by a fixator clamp.

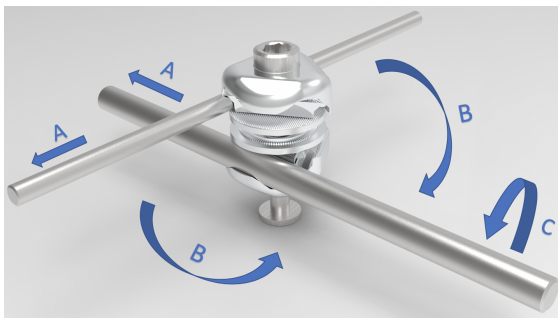

Figure 1. The different parameters controlled by an external fixator clamp. A) Fixator-pin and connecting-bar slippage. B) Clamp-axis-pivot. C) Fixator-pin and connecting-bar rotation.

Six different parameters should be considered when comparing the two types of external fixator clamps. These parameters, shown in figure 1, are the following: fixator-pin slippage along the axis of the pin; connecting-bar slippage along the axis of the bar; fixator-pin rotation; connecting-bar rotation; clamp-axis-pivot in the clockwise and counterclockwise direction. These parameters described the movement controlled by an external fixator clamp (6).

The behavior of the two type of clamps with respect to four of the parameters is assessed in this study. Slippage tests were performed for 4mm- and 5mm fixator pins and 8mm connecting bars (A). In addition, rotation was examined of 4mm- and 5mm fixator pins and 8mm connecting bars (B). Clamp-axis-pivot testing was excluded from this analysis, due to a lack of appropriate equipment.

MATERIALS & METHODS

Two types of external fixator clamps were studied: the universal clamp (Technical University Delft, Delft, The Netherlands), and the Hoffmann 3 clamp (type:4992-1-020, Stryker Corp.), shown in figure 2. Four clamps

of each type were weighed using a scale (Kern; FKB 30K1A). The average weight of each clamp was recorded.

This study uses four clamps of each type to investi-

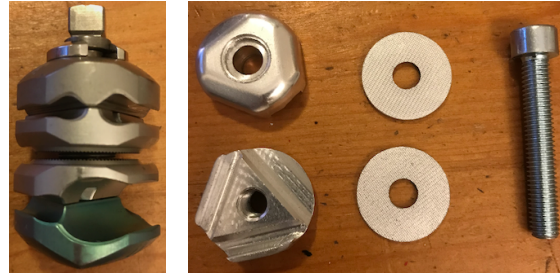

Figure 2. The two external fixator clamp types used in this study. Left, the Hoffmann 3 clamp. Right, the components of the universal clamp.

gate the mechanical force required to initiate movement at the fixator-pin-clamp and connecting-bar-clamp connection. In order to isolate the interface of interest, a specified fixture and method was designed. The manufactured fixture, shown in figure 3, was made out of Al7071-T6 and characterized by dimensions to fixate both clamp types.

The applied testing forces on the clamp were subjected directly on the components involved, instead of through a second component. In case of involvement of second components, it was attempted to reduce the influence by limiting the distance between the clamp and the point of applied force. In these conditions, clamp failure is

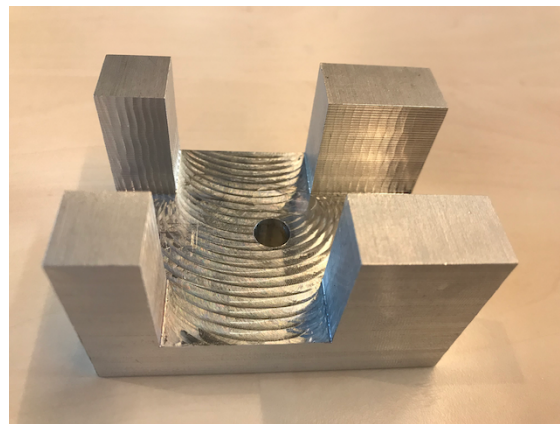

Figure 3. The fixture used for the mechanical tests of the Hoffman 3 clamps and universal clamps, manufactured from Al7071.

more likely to occur than fixator-pin or connecting-bar bending. These testing circumstances are in accordance with the technique described in ASTM F1747-96, Standard Test Method for External Fixator Joints, American Society for Testing and Materials (ASTM) (F1747-96).

The Hoffmann 3 clamp and the universal clamp dif-

ferred in fixator-pin and connecting-bar sizes. The universal clamp (Technical University Delft) allowed 4- and 5-mm fixator pin and 8mm connecting bar fixation; the Hoffmann 3 clamp (Stryker Corp.) used 4-, 5- and 6-mm fixator pin and 5-, 8-, and 11-mm connecting bar fixation (1). The overlapping diameters for fixator-pin fixation and connecting-bar fixation, 4- and 5mm and 8mm respectively, were used in this study. Fixator pins and connecting bars had a length of 150mm and were attached 90° relative to each other as shown in figure 4. The clamps were subjected to six mechanical tests, at three tightening torques. After each test, the clamps were disassembled and washed in an ultrasonic bath with detergent solution to remove oil and dirt residue from the metal components. In order to minimize variation due to contaminants, the clamps, fixator pins, and connecting bars were handled with powder-free latex gloves. A total of eight clamps, four of each clamp type, were tested at three tightening torques for each of the six parameters. Therefore, a total of 144 tests were conducted. The torques were roughly determined by the maximum torque five surgeons at Tufts University School of Veterinary Medicine could generate with a screwdriver type wrench (4.4 N-m) and an open-end wrench with a 100-mm handle (7.8 N-m). A torque halfway between these values was also evaluated.

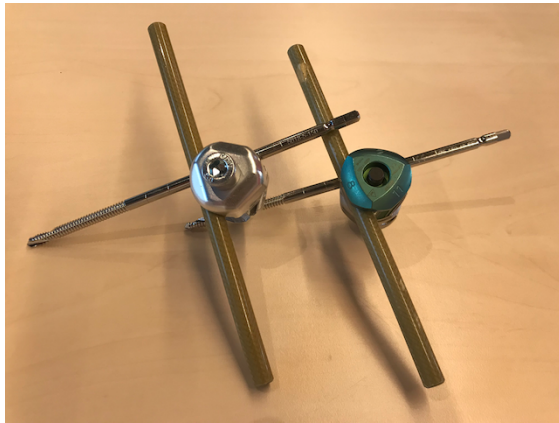

Figure 4. The two external fixator clamp types assembled with fixator pins and connecting bars in the cross-configurations used for mechanical testing.

Testing procedures

Fixator-pin and connecting-bar rotation

First, each clamp was subjected to the fixator-pin rotation test. To test fixator-pin rotation, the connecting bar was fixated on the fixture, holding the connecting bar stationary and aligned. The input element, the fixator pin, was grabbed by a drill chuck at 1cm from the clamp as shown in figure 5. A torsional force was applied about

the axis of the fixator pin using two adjustable torque screwdrivers. The first had a range from 0,3 – 1,2N (Wera; model 7440 ESD), the second diverged from 1 – 10N (AOK; model TSW10N). The torque wrench allowed manually installing the amount of force that had to be exerted, and had a clockwise accuracy of $\pm 6\%$. Torque was applied until rotation was observed. The highest torque value was reported.



Figure 5. Hoffmann 3 clamp fixed in the test setup for fixator-pin and connecting-bar rotation.

The clamp was assembled with a 4mm fixator pin and connecting bar, and tightened at 4.4 N-m, tested, then tightened to 6.1 N-m, tested without any other changes, and finally tested at a torque of 7.8 N-m. In between the rotational tests, the testing conditions were tried to be kept constant in order to optimize the results. The components of the clamp were loosened, and the test was repeated for the 5mm fixator pin in combination with the connecting bar. Connecting bar rotation was tested by fixation of the 5mm fixator pin and applying torsion on the 8mm connecting bar. After the execution of the same testing sequence, the clamp components were disassembled and inspected for plastic deformation.

The first four of each clamp type were tested bottom-up, starting from 4.4 N-m and ending with 7.8 N-m. The testing sequence for the other four clamps was top-down, starting with 7.8 N-m and descending to 4.4 N-m.

Fixator-pin and connecting-bar slippage

Subsequently, fixator-pin slippage was examined for each clamp. The testing fixture was manufactured to allow for stable seating of the clamp. The cross-component and the clamp were supported by the fixture, while the axis of the fixator pin or connecting bar was equally aligned with the axis of the input load. This minimizes the error from elastic deformation, when analyzing the slippage point of the fixator pin or the connecting bar. The testing figure was mounted onto the testing frame, shown in figure 6.

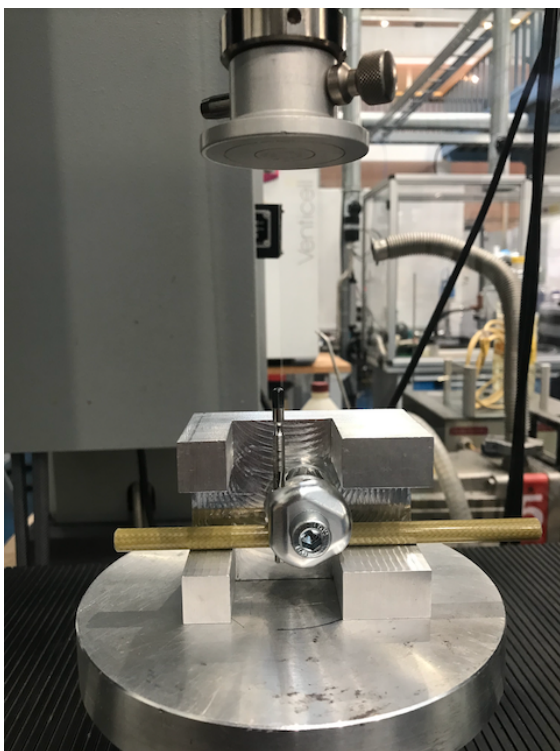

Figure 6. Universal clamp fixed in the test setup for fixator-pin and connecting-bar slippage.

The fixator-pin slippage test consisted of applying a load on the 4-mm or 5-mm fixator pin, while the clamp was fixated on the fixture. The fixator pin slippage was measured, by applying axial load on the end of the pin. The test setup was stabilized with a preload of 15N and the force to slip the pin was recorded over a 2-mm distance at 0.1mm/s using a linear actuator (Lloyd Instruments; LR5K). The slippage point was determined by analysis of the load-time data. Connecting bar slippage was tested, by applying axial load on the connecting bar at similar conditions to fixator pin testing.

First the 4mm fixator pin was tested, while the connecting bar anchored the clamp, followed by the 5mm fix-

ator pin. Thereafter, connecting-bar slippage was tested, using an equal setup by fixating the 5mm pin and applying load to the connecting bar. The test was carried out at 4.4 N-m, 6.1 N-m, and 7.8 N-m, respectively. The testing order for the first four of every clamp type was bottom up, starting from 4.4 N-m and ending with 7.8 N-m. A top-down testing sequence was applied for the other four components, starting with 7.8 N-m and descending to 4.4 N-m.

Statistical Analysis

A two-way repeated-measures ANOVA was used for the statistical analysis. The data was logarithmic transformed before the analysis in order to decrease the heterogeneity of the variances. The Bonferroni adjusted pairwise multiple comparison method was used to determine the statistical significance of the bolt torque and diameter between the Hoffmann 3 clamp and the universal clamp. A significant difference was conducted of $P < 0.05$.

RESULTS

For all performed tests is the average force and standard deviation summarized in table 1, and visualized in figure 7. The average maximal torque is reported for fixator-pin and connecting-bar rotation. For fixator-pin and connecting-bar slippage and, the average maximal force is reported.

Fixator-pin and connecting-bar rotation

The Hoffmann 3 clamp provided significantly greater resistances to 4mm, 5mm fixator-pin rotation and 8mm connecting-bar rotation in comparison with the universal fixator at all three tightening torques. The repeated measures ANOVA showed that the mean torque differed significantly between the two groups, $F(1,6) = 68.985$, $p < 0.05$, $\eta^2 = .920$. There was a statistically significant effect of diameter on rotational force, $F(2,12) = 83.211$, $p < 0.05$, $\eta^2 = .933$. Also, a significant effect of bolt torque was found, $F(2,12) = 140.225$, $p < 0.05$, $\eta^2 = .959$.

Fixator-pin and connecting-bar slippage

The Hoffmann 3 clamp withstood significantly greater force before slipping occurred at all tested parameters in comparison with the universal clamp. The repeated measures ANOVA showed that the mean load differed significantly between the two clamp types, $F(1,6) = 105.357$, $p < 0.05$, $\eta^2 = .946$. A statistically significant effect of diameter was found on slippage force, $F(2,12) = 92.033$, $p < 0.05$, $\eta^2 = 0.939$. With respect to the bolt torque, no statistical effect was found, $F(2,12) = 2.737$, $p > 0.05$, $\eta^2 = .313$.

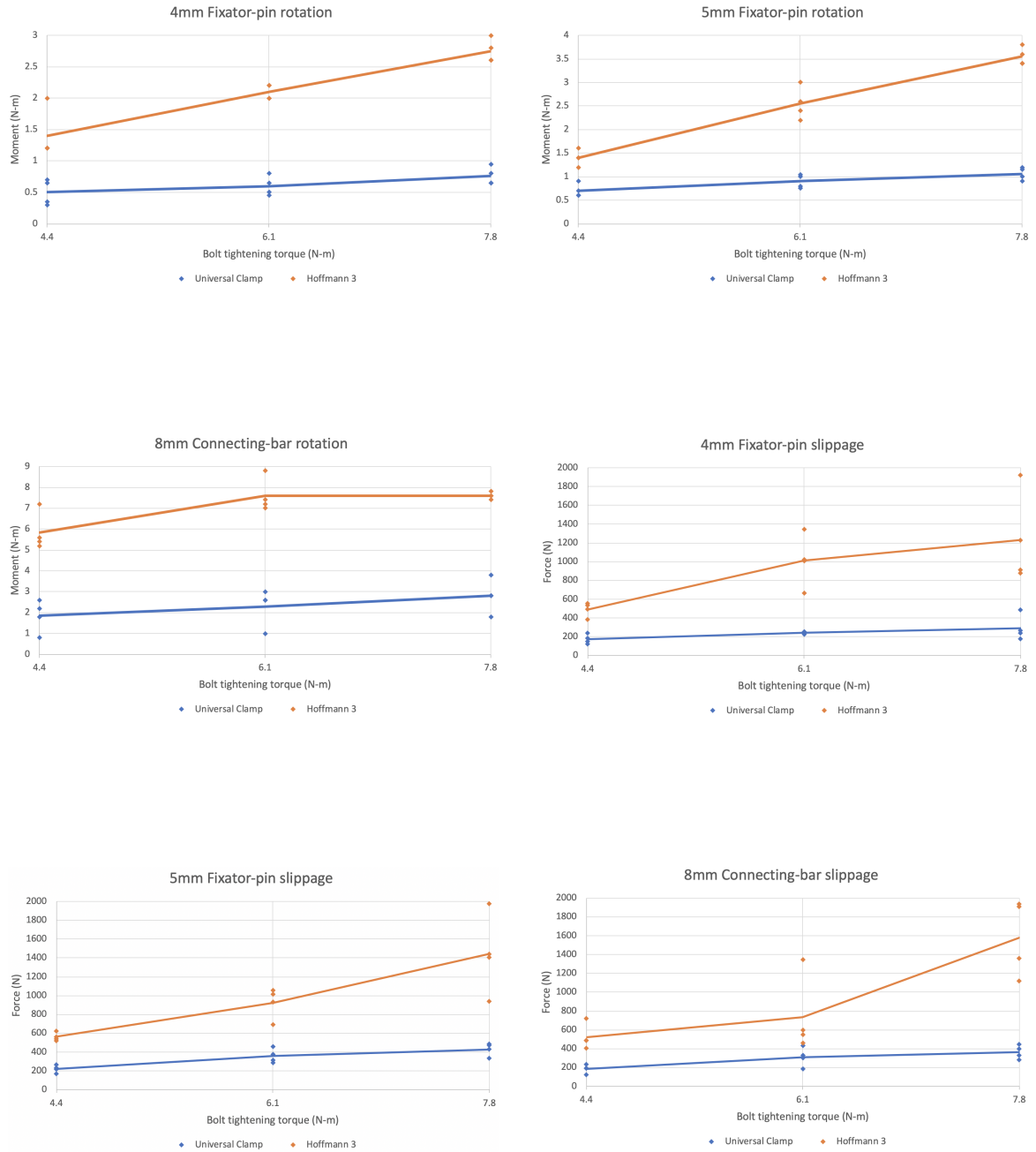

Figure 7. Average force and standard deviation for rotational and slippage tests of the three different diameters. Blue line indicating the mean results of the universal clamp. Orange line representing the mean results for the Hoffmann 3 clamp. Individual measurements are represented with coloured points.

Table 1 The average and standard deviation for the performed fixator-pin rotation (FPR), connecting-bar rotation (CBR), fixator-pin slippage (FPS), and connecting-bar slippage (CBS) tests.

Clamp type	Bolt torque (N-m)	4mm FPR (N-m)	5mm FPR (N-m)	8mm CBR (N-m)	4mm FPS (N)	5mm FPS (N)	8mm CBS (N)
Universal clamp	4.4	0.50 ± 0.20	0.70 ± 0.14	1.85 ± 0.77	174.05 ± 49.46	222.20 ± 41.48	182.48 ± 44.19
	6.2	0.60 ± 0.16	0.90 ± 0.15	2.30 ± 0.89	245.20 ± 11.51	357.53 ± 75.57	308.53 ± 100.04
	7.8	0.76 ± 0.14	1.06 ± 0.14	2.80 ± 0.82	292.90 ± 133.87	431.00 ± 68.14	360.63 ± 74.70
Hoffmann 3	4.4	1.40 ± 0.40	1.40 ± 0.16	5.85 ± 0.91	493.65 ± 75.86	561.75 ± 43.36	523.98 ± 136.56
	6.2	2.10 ± 0.12	2.55 ± 0.34	7.60 ± 0.82	1010.13 ± 276.72	924.13 ± 161.11	735.78 ± 408.54
	7.8	2.75 ± 0.19	3.55 ± 0.19	7.60 ± 0.16	1235.03 ± 484.11	1440.88 ± 425.88	1576.13 ± 404.09

DISCUSSION

In this study the mechanical behavior of the universal prototype clamp was assessed with respect to two mechanical parameters in a comparison with an advanced external fixator clamp. In order to ensure adoption of the universal clamp prototype, performance evaluation is crucial. The Hoffmann 3 external fixator set is successfully implemented in clinical settings, and is therefore considered as relevant target measurement. The results of the mechanical analysis show that the universal clamp provides significant less stability in comparison with the Hoffmann 3 clamp.

External fixator systems have been the subject of numerous evaluation studies, however limited research has been conducted on mechanical testing of external fixator clamps. Gilley *et al.* have studied the mechanical properties of three external fixator clamps with respect to six parameters. They state that the slippage and rotational tests should be performed as these reflect part of the forces the clamp is exposed to when implanted in the patient (6).

In comparison with the Hoffmann 3 clamp, provides the universal clamp significant less resistance to rotational forces. The first two rotational tests of the universal clamp were performed using carbon fiber connecting bars. However, due to observed plastic deformation at the tip of the connecting bar, these were replaced by stainless steel connecting bars. In order to obtain clean results, the first two tests were repeated for the universal clamp. As a consequence, the first two universal clamps were subjected to three more rotational tests in comparison with the other clamps. It is expected that this does not affect the outcomes of this study.

The results show that the universal clamp provides significantly less resistance to slippage. Little plastic deformation was observed at the lower component and upper component, but a significant amount at the two friction disks located in between these components. In figure 8 a comparison is presented of the friction disk prior to and after slippage testing. The friction pattern of the disk was flattened after performing the slippage tests and resulted in a smooth surface of the friction disks. As a consequence, less friction resistance was exerted throughout the sequence of testing. To improve the reliability and validity of the testing results and

correct for potential measurement bias, the sequence of testing differed for two clamps of each type. In all universal clamps, plastic deformation was observed after execution of the slippage tests. However, no plastic deformation was detected in the Hoffmann 3 clamps. Throughout the testing sequence, this likely benefited the capacity of the Hoffmann 3 clamp to withstand the slippage forces.

An important factor that has to be taken into account is the material usage with respect to the universal clamp. To ease manufacturability and decrease costs, Al6061 was selected to manufacture the universal clamp. The smaller tensile stiffness of this aluminium alloy in comparison with the titanium Hoffmann 3 clamp, results in an adverse effect with respect to the friction provided. In further research should the use of materials be reconsidered to improve the stiffness of the universal clamp. While considering the fundamental goal of the universal clamp to provide a low-cost treatment for open fractures, sufficient stability should be provided to the bone fragments.

**Figure 8.** Plastic deformation of one of the friction disks of the universal clamp. Left: prior to testing, right: after testing.

The external fixator clamp controls several movement parameters, shown in figure 1. In addition to the performed mechanical tests, clamp-axis-pivot testing is recommended in future research. This mechanical test is defined as rotation of the fixator-pin or connecting-bar about the axis of the clamp bolt (6). Due to a lack of appropriate equipment, this test was disregarded in this setting. However, observing the plastic deformation in the universal clamp as a result of slippage testing, suggests comparable effects in clamp-axis-pivot testing. The

knurled components of the friction disks that interlock upon assembly, imply to be critical features during these tests in clockwise and counter clockwise direction. Especially for the Hoffmann 3 clamp, as the secured fixator pin or connecting bar is shape fitted. Similar results to the study of Gilley *et al.* is expected, as the open face was plastic deformed at the fixator-pin housing due to the interlocking effect of the knurled surfaces of the clamp (6).

When an external fixator is subjected to axial loading, unilateral external frames demonstrate cantilever bending with asymmetric loading at the fracture site (4). Axial loading at the fracture site results in a cantilever bending moment at the pins, subjecting the clamps of the external fixator to clamp-axis-pivot movement. When plastic deformation is observed during clamp-axis-pivot testing that leads to destroying the clamp, the threshold should be evaluated. The amount of force the clamp is subjected to during testing, must be put in perspective with the forces to be resisted when implanted in the patient.

The Hoffmann 3 clamp showed significant higher slippage force in comparison with the universal clamp. However, the development of force building of the clamp types differed in various test cases. Figure 9 displays the typical trend of the load-time data of both types of external fixator clamps during slippage testing. The deformation pattern shown in figure 9a can be characterized as a typical trend. Force is built up by the applied slippage force to a critical point, that the axial force exerted is higher in comparison with the generated friction by the universal clamp. This critical point is observed at $t = 4.7s$. The axial load decreases and reaches a plateau phase, where the friction component is in equilibrium with the axial force.

The load data of the Hoffmann 3 clamp shows different trend. In figure 9b, the critical point can be observed at $t = 17.2s$. The force shows a linear upward trend after the point of slippage. For a possible explanation, the design of the Hoffmann clamp should be considered. A spring mechanism is incorporated in the design, easing the assembly during the operation. This so-called snap-fit system exerts force when the housing components of the fixator pin or connecting bar move relative to each other. This spring mechanism also explains the fluctuating movements of the upward line.

Another remarkable observation was the range of outcomes in the slippage tests of the Hoffmann 3. The results varied considerably between the clamps, implying a difference in performance level. This was not observed in the slippage outcomes of the universal clamp. Wear of the used Hoffmann 3 clamps was expected to contribute to this observation. This is in accordance with the research of Gilley *et al.*, stating that repeated use of external fixator clamps degrades the mechanical performance (5). The universal clamps were manufactured

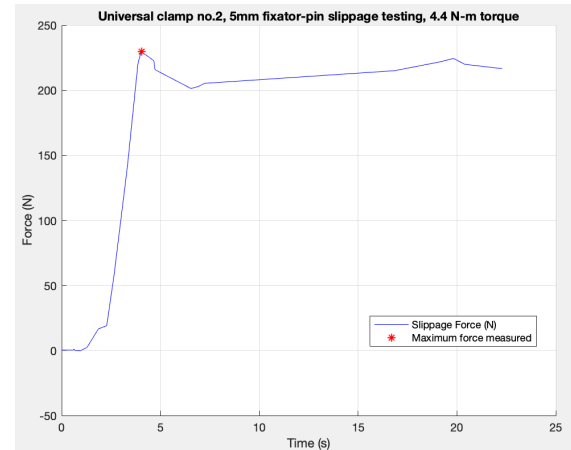

(a)

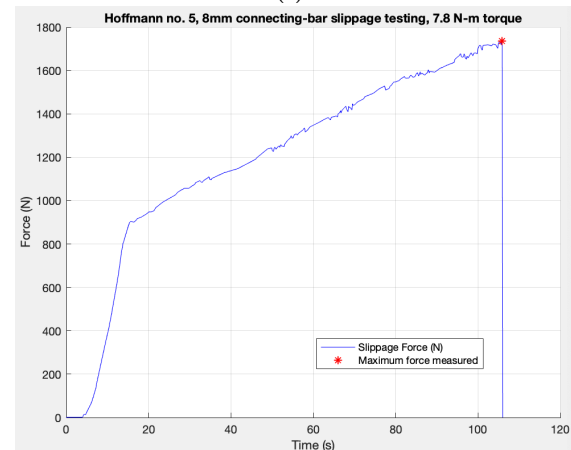

(b)

Figure 9. Load-time curve of slippage testing, typical measurement trend seen in: a) Universal clamp b) Hoffmann 3 clamp. Red star indicates the maximum load observed.

for the purpose of this mechanical analysis and were not previously subjected to fixation forces.

Another factor contributing to this effect could be the wear observed in the fixture. As a result of iterative measurement of both clamp types, wear was observed in the central hole of the fixture. Due to the geometry of the universal clamp, less impact was expected. In future research is advised to form fit the fixture to both clamp types or replace the fixture after a number of iterations.

With a small sample size interactions between the two types are difficult to examine. Increasing the number of iterations or the number of clamps is advised in order to validate the outcomes. However, a significant high effect size was found in both variables diameter and bolt torque. Therefore, this interaction effect is expected when the number of clamps is increased.

In conclusion, the universal clamp provides less stability to open fractures in comparison with the Hoffmann 3 clamp. In order to enhance the performance of the universal clamp to be successfully adopted in LMICs, further development of the design should be considered. Evaluation of the mechanical properties of external fixator clamps is essential to ensure stability is provided to the open fracture. The performed slippage and rotation tests are useful in the assessment of the mechanical behavior of the clamps. In addition, clamp-axis-pivot testing is advised to complement all movement parameters controlled by the external fixator clamp.

ACKNOWLEDGEMENTS

The author thanks the Amsterdam University Medical Centre for contributing the materials used in this investigation, and Ing. M.A. Leeftang, TU Delft, for assistance with performing the mechanical slippage tests.

REFERENCES

- [1] Cardozo, R. T., Silva, L. G., Bragante, L. A., and Rocha, M. A. (2013). Treatment of fractures of the tibial diaphysis using external fixator compared with locked intramedullary nails. *Revista Brasileira de Ortopedia (English Edition)*, 48(2):137–144.
- [2] Cross III, W. W. and Swiontkowski, M. F. (2008). Treatment principles in the management of open fractures. *Indian journal of orthopaedics*, 42(4):377.
- [F1747-96] F1747-96, A. Test method for external fixator joints (withdrawn 2000). ASTM International, West Conshohocken, PA,.
- [4] Fragomen, A. T. and Rozbruch, S. R. (2007). The mechanics of external fixation. *HSS Journal*, 3(1):13–29.
- [5] Gilley, R. S., Beason, D. P., Snyder, D. M., Boston, R. C., Radin, A., Kapatkin, A. S., Smith, G. K., and Soslowsky, L. J. (2009). External fixator clamp reuse degrades clamp mechanical performance. *Veterinary Surgery*, 38(4):530–536.
- [6] Gilley, R. S., Bourgeault, C. A., Wallace, L. J., and Bechtold, J. E. (2001). A comparative mechanical study of 3 external fixator clamps. *Veterinary Surgery*, 30(4):341–350.
- [7] Latifi, R. (2019). *The Modern Hospital: Patients Centered, Disease Based, Research Oriented, Technology Driven*. Springer.
- [8] Meara, J. G., Leather, A. J., Hagander, L., Alkire, B. C., Alonso, N., Ameh, E. A., Bickler, S. W., Con-
te, L., Dare, A. J., Davies, J., et al. (2015). Global surgery 2030: evidence and solutions for achieving health, welfare, and economic development. *The Lancet*, 386(9993):569–624.
- [9] O'Neill, K. M., Greenberg, S. L., Cherian, M., Gillies, R. D., Daniels, K. M., Roy, N., Raykar, N. P., Riesel, J. N., Spiegel, D., Watters, D. A., et al. (2016). Bellwether procedures for monitoring and planning essential surgical care in low-and middle-income countries: caesarean delivery, laparotomy, and treatment of open fractures. *World journal of surgery*, 40(11):2611–2619.
- [10] Spiegel, D., Nduaguba, A., Cherian, M., Monono, M., and Kelley, E. (2015). Deficiencies in the availability of essential musculoskeletal surgical services at 883 health facilities in 24 low-and lower-middle-income countries. *World Journal of Surgery*, 39(6):1421–1432.

12

Discussion

The aim of this thesis was to develop a low-cost external fixator for application in LMICs. The universal fixator combines different clamp configurations, reducing the number of components needed to provide open fracture treatment. In comparison with its predecessor it is reduced in weight, has been improved in functionality, and provides more stability. There are points of improvement to be noted to improve the performance and make it comparable with existing state-of-the-art external fixator clamps, but serves as a promising prototype to be eventually adopted in the Lifebox set for open fracture treatment.

This thesis identifies the specific clinical needs of the product, that are translated into functional and non-functional requirements. Based on these needs the product requirements were defined, serving as input for the prototype development of the universal clamp.

Building on the knowledge gathered from the input sources, focused is on providing solutions for development of the clamp design. The importance of individual components was discussed and improvements in the clamp design were considered in an iterative design process with the engineering team and the clinical team. The conceptualization of the prototype was guided by specifying three subproblems: stability enhancement, weight reduction, and increasing functionality. Without compromising the functionality of the technology the fixation technique is based on, modules were redesigned, introduced, or supplemented. A material analysis, followed by an evaluation of the theoretical mechanical behavior of the developed clamp concept, contributed to the development of the final design of the universal clamp. In order to examine its performance, the final design was manufactured and mechanically tested.

The most important factor throughout the design process of the universal clamp was to minimize the costs. To ensure adoption of the developed open fracture treatment in LMICs, cost-effectiveness of the clamp served priority, taking into account the constraints that it provided stability, functionality, safety, and minimal weight. These factors will be evaluated in the next paragraphs.

Costs

In circumstances where medical technology is unaffordable or unavailable, innovations in medical device development flourish [16]. In order to satisfy the demand of providing medical care to a large number of people with limited resources, uncomplicated and cost-effective treatment should be developed for the specific target group. Awareness is growing that simplicity in developing medical devices is also beneficial for HICs. If the performance and clinical outcome of a simple system is equivalent to a complex system, the financial benefit is highly relevant. In addition, if a simple system is easier to use and less susceptible to failure because of the robust design, this is a clear advantage.

The universal clamp was designed with the goal to reduce manufacturing costs and meet the target of staying below €500,-. Indicated by the manufacturer of the prototype, are the costs of producing one clamp €24,77 when purchasing 500 pieces. The minimal box, containing the minimal amount of

components to treat open fractures in LMICs, consists of eight clamps. This brings the total amount on €198,16 for the necessary clamp components. In comparison with the Hoffmann 3 clamp developed by *Stryker Corp.* is the price for one pin-bar clamp €340,00, shown in Appendix D. Therefore, the prototype meets the cost specification of the product requirements.

Stability

To examine the stability the universal clamp provides, it was subjected to two mechanical tests. The performance of the universal clamp in a comparison with the Hoffmann 3 clamp proved to be significantly lower on both the slippage tests as the rotational test. Therefore, the universal clamp provided inadequate resistance to axial force as both rotational force. To improve the fastening grip of the universal clamp on the fixator pin or connecting bar, the primary adjustment that has to be considered is the use of materials. Plastic deformation of the friction disk was observed, as a result of the choice for aluminium 6061 as manufacturing material. In order to improve the gripping force, materials with a higher YM could be opted for such as stainless steel or titanium to provide more stiffness to the universal clamp. Recommended is to opt for titanium, as this provides more stiffness to the clamp marginally at the expense of the weight of the clamp. Widely used in medical devices, its high-performance and low density are attractive in the development of external fixation systems.

Interpretation of the outcomes of the mechanical tests and translating these results into the forces experienced in the patient when the external fixator is installed must be considered. Currently, no specific guidelines regarding mechanical performance are available for external fixator clamps. When studying the mechanical behavior and performance of the unilateral clamp in a comparison with an advanced clamp, it raises the question to what extent the universal clamp must comply with this advanced type. Future research should be conducted to map these experienced clamp forces of equivalent external fixator systems, to provide performance guidelines in the development of external fixator clamps. Using these guidelines it can be determined whether the universal clamp provides sufficient stability to be adopted as open fracture treatment in LMICs.

Functionality

The functionality of the universal clamp was improved by introducing the spring system in the clamp design. During the operation, this supplemented feature facilitates the assembly of the external fixator with the consequence to enhance the ease of use. Two types of disc springs were purchased differing in thickness and disc height. With a corresponding outer diameter of 15.88mm and inner diameter of 8.05mm , both types fitted in the spring compartment. In this trial-and-error process, the first disc spring had a thickness of 0.56mm and a disc height of 1.07mm , the second disc spring a thickness of 0.81mm and a disc height of 1.22mm . However, regardless of the stacking configuration of disc springs no desired spring effect was obtained. Considering the height of the spring compartment in the friction disk, limited amount of disc springs can be fitted in the compartment. Enlarging the thickness of the friction disk would benefit the snap-in technology of the universal clamp. Also, it would provide more stiffness and therefore improve the fastening capacity of the overall clamp system. With this increased thickness of the friction disk, the optimal configuration of disc springs could be searched for.

The first mechanical test performed examined the resistance to rotational forces of both clamp types. Carbon fiber connecting bars were used for the connecting-bar rotation tests. As a result of tight clamping of the connecting bar to secure the rotational testing mechanism, plastic deformation was observed at the tip of the connecting bar. In addition, rotation of the connecting bar between the clamp component and the friction disk induced plastic deformation of the carbon fiber connecting bar. Therefore, after two performed rotational tests, the carbon fiber connecting bars were replaced with stainless steel connecting bars. This outcome questions the functionality of the friction disk. The design of the friction disk must not cause damage to the other associated components, which would be exacerbated when opting for harder materials. Reconsideration of the friction disk in the design of the universal clamp is therefore recommended in further research. No significant plastic deformation was observed in the upper- and lower component, indicating that the critical force concentration was located at the friction

disk. The outcomes of the mechanical tests do not give cause to question the design of the upper and lower clamp components.

Safety

The introduction of the 55mm screw with rounded top and soldered end cap reduced the risk of losing components. In addition, sterilization has been simplified by the introduction of this adjusted screw, which ensures that safety during treatment was promoted. As most hospitals have autoclaves available in LMICs, safety of the universal fixator is enhanced by improving sterilization [78].

Another factor, contributing to the safety of the universal clamp, is the thread engagement length. In the current clamp design a length of 12mm was actualized. The maximum torsional load applied on the screw was 7.8 N-m and provided the greatest resistance in all mechanical tests. No slippage of the screw was inspected inside the clamp at this torque, suggesting that the used thread engagement length in the clamp was sufficient. However, taking into account that reuse of clamps degrades mechanical performance, it should be considered to adjust this 12mm to 16mm. Safety is of utmost importance in the development of medical devices, and clamp failure must unquestionably be avoided [4].

Weight

The total weight of the universal clamp was reduced in comparison with the three-way-clamp by implementation of the design improvements. The total weight of the universal clamp was 46g, which is significantly lower in comparison with the Hoffmann 3 clamp weighing 87g. In accordance with previous studies, low weight of the external fixator system is important in the optimization of the healing process and to improve the wearing comfort of the patient [71][10]. This would result, according to the study of Tomanec *et al.*, in a reduction of the heart rate and thus oxygen consumption of the patient.

12.1. Limitations

Some limitations should be noted throughout the design process and the mechanical evaluation of the universal clamp. Firstly, working with engineering specialists who are focused on one specialism can result in bias, especially during the conceptualization of the universal clamp. Therefore, close collaboration with the clinical team was essential to successfully adopt the prototype in the clinical setting. Secondly, limited financial resources were available for the project. This affected the selection of the material to manufacture the clamp prototype. Also, it influenced the number of clamp prototypes to be produced for the mechanical tests. Thirdly, the student version of SolidWorks 2019 was accessible, limiting the researcher in the FEA of the clamp concept. As a result of this approach, contact surfaces were not feasible and contact sets had to be applied. Fourthly, the use of materials was based on the materials available in the CES EduPack 2019 database. Fifthly, limited research has been conducted on mechanical testing of external fixator clamps. Therefore, the research of Gilley *et al.* served as a guideline for the mechanical evaluation of the clamp prototype [30]. Sixthly, limited testing equipment was available to perform all three mechanical tests. Therefore, four out of six parameters were tested that are controlled by the external fixator clamp [30]. Consequently, these limitations might be reflected in the results of this study.

12.2. Recommendations for further development

To further develop the prototype of the universal fixator, it is suggested to reconsider the implementation of the friction disk. Implementing a form-fit component could benefit the functionality and improve the performance. In addition, it is recommended to implement a snap-in system in this component to enhance the ease of use for the treating physician.

The use of materials was not suitable for this application. Therefore, opting for a stronger material

such as titanium or stainless steel, should be considered to enhance the performance of the universal clamp during mechanical testing. Although this would adversely affect the costs of manufacturing, it is expected to improve the performance of the clamp.

In order to evaluate the mechanical performance, it is recommended to perform all three mechanical tests explained in section 11. This includes the clamp-axis-pivot testing, which was not performed in this project. This testing method seems viable to evaluate the mechanical behavior of an external fixator clamp. Suggested is to formulate worldwide standards and guidelines for the evaluation of external fixator clamps, to guarantee stabilization is provided by external fixator clamps.

In addition, repeated cycles testing and sterilizability testing is advised to examine the effect of reuse on mechanical performance of the universal clamp. Also, to improve the safety of treatment it is recommended to analyze the ease of sterilization.

After the proof of concept of the refined universal clamp is established, larger quantities have to be produced for clinical implication studies to determine whether the clamp can be successfully adopted in clinical settings in LMICs.

To minimize manufacturing costs, a production plan needs to be prepared. In the next steps it should be considered to have components locally produced or opt for one manufacturer.

In collaboration with GSA, clear training modules should be developed and local partnerships have to be established to ensure the adoption of a complete Lifebox set of the universal fixator to treat open fractures in LMICs.

13

Conclusion

In order to implement the universal fixator as a Lifebox-idea to treat open fractures in LMICs, the development of the universal clamp prototype is a first step in its realization. With the primary focus on cost-limitation during this iterative design process of the universal clamp, decisions were taken to benefit this requirement. Although the prototype design is promising, the performance is lacking in this phase. To improve this, concessions may need to be made on the cost of production. Implementing design alterations and reconsideration of the use of materials will benefit the performance of the universal clamp. The researcher is convinced that these adjustments will lead to a more promising universal clamp to be successfully implemented in LMICs. This universal clamp will be the fundamental component of the Lifebox set to provide widespread access to safe and affordable open fracture treatment.

Appendices

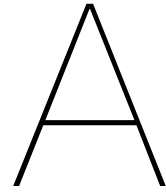

Manual external fixation procedure

Principles

Modular external fixator

The modular external fixator is designed for the treatment of the most common open fractures like tibia and fibula fractures. It has also the possibility to be used with smaller pins for the upper extremity. It is rapidly applied even in settings where an intraoperative x-ray is not available.

The frame of a modular external fixator consists of two partial frames, one on each main fracture fragment. Each partial frame starts with two pins (a) in a bone fragment, connected with a clamp (b) to a pinbar (c). The two frames are joined with a bar-to-bar construction/connecting bar (d).

This allows manipulation and reduction of the fracture after pin placement and guarantees sufficient stiffness of the frame. It also allows pins to be inserted through safe zones, avoiding traumatized soft tissues.

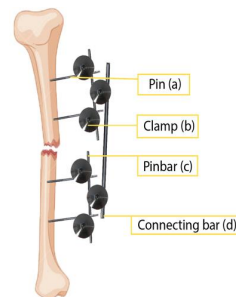

Optimal frame construction

For the construction of the frame consider the following points:

- Pins are placed near the fracture site, but not too close and avoiding traumatized soft-tissue (A).
- Pins are placed widely separated in each main fracture fragment (B).
- pinbars are connected to the pins with clamps (C).
- The clamps are fully tightened so that each main fragment has its own partial frame.
- The two partial frames are interconnected using a connecting bar.
- At this point good reduction of the fracture should be obtained
- The clamps are first provisionally tightened with the hand and then fully tightened using a hex wrench.

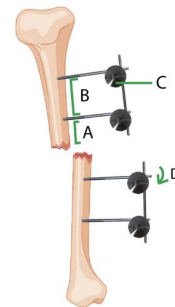

The stiffness of the frame may be increased by the following options:

- Positioning the pinbar closer to the bone
- Adding a second connecting bar (neutralization bar) (e) between the partial frames
- More pins in each segment

Equipment needed

For the construction of the frame the following components are needed (shown for the large external fixator):

1. Connection Bar (8 mm)
2. Pin (4x) (4 mm)
3. Pin (4x) (5 mm)
4. Pinbar (2x) (8 mm)
5. Depth measurer (Rubber)
6. Universal clamps (6x) (Stainless Steel, self-holding)
7. Battery charger
8. Drill



Pin Insertion

Pin placement

Two pins should be inserted in each of the proximal and distal fragments in the safe zones, place the closest pin ideally not closer than two fingers away from the fracture.

The risk of tendon penetration or injuries to nerves, vessels, and muscles is determined by the anatomy of each region. Pins should not enter a joint cavity. This is described below.

When possible the use of the image intensifier is recommended to facilitate optimal and safe pin placement.

In temporary external fixation, the pins should be placed at positions not interfering with planned later definitive fixation later.

Safe Zones of the Tibia for pin insertion

Proximal part of the proximal tibia

The peroneal nerve runs posteriorly at the level of the fibular head and curves anteriorly as it goes caudal.

Transfixation

The medial and the lateral zones at the level of and ventral to the fibular head are the only safe zones for tibial transfixation.

Unilateral fixation

The anterior zone on both sides of the patellar ligament is safe for unilateral fixation.

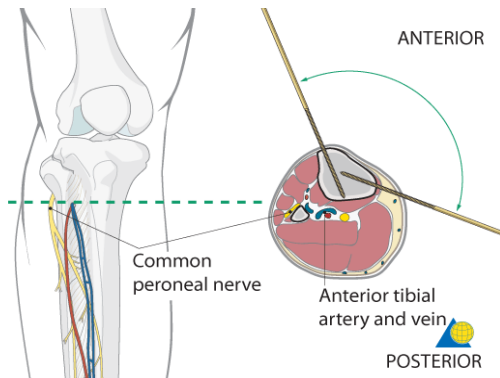
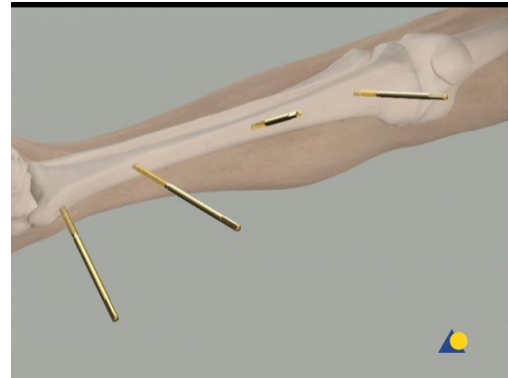

Proximal third – distal of the tibial tuberosity

Distal to the tibial tuberosity only unilateral external fixation is safe.

It is best to insert the pins where soft-tissue coverage is minimal as the risk of pin track infection is lowest.

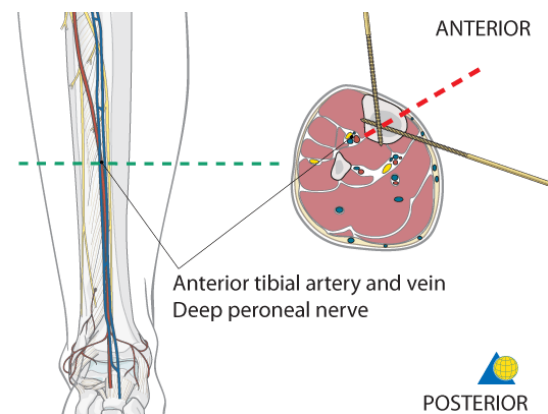

Middle zone of tibia

The neurovascular bundle with the anterior tibial artery and vein together with the deep peroneal nerve are running close to the posterolateral border of the tibia. They are at risk if the pin is inserted in the way indicated by the red dotted line.

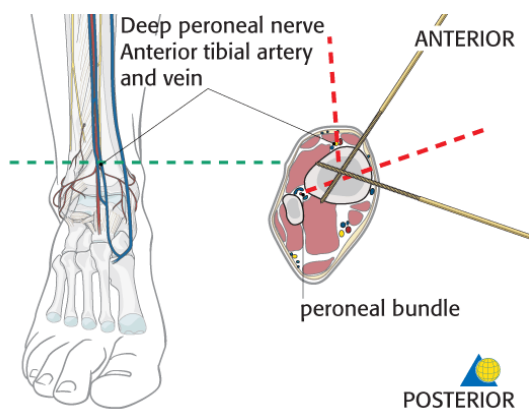

Distal zone of the tibia

When inserting pins in the distal zone take into account the position of the anterior tibial artery and vein. Percutaneous insertion of pins in this area is dangerous. A minimal incision will allow preparation and safe insertion.

The peroneal bundle is located very close to the posterolateral border of the tibia and therefore at risk if pins are inserted in this direction. Pins at this level should be inserted as shown in the illustration from anteromedial to posterolateral. A second pin can be inserted from medial to anterolateral, ventral to the fibula.

Skin Incision

The position of each skin incision is determined by the pin position. As the fracture is reduced, the pin may move in relation to the skin, and the incision may then need to be extended in order to release any tension in the skin. If possible, this may be anticipated and the initial skin incision may be adjusted accordingly.

Predrilling

It is essential to predrill both cortices prior to the insertion of threaded pins.

Place a drill sleeve with trocar through the prepared soft-tissue channel to prevent damage to soft tissues, and confirm correct positioning. The use of an image intensifier may be beneficial to determine correct pin trajectories.

Drilling through cortical bone should be performed under cooling to prevent heat formation followed by bone necrosis.

Pin insertion (Conventional threaded pins)

Insert conventional pins by hand using the corresponding drill sleeve.

By using the depth meter it is possible to see on the drillbit how far the pin should go in the bone. The depth meter is placed on the drillbit when it is through the second cortex. This should be done on right above the skin. After this, the drillbit is removed and placed next to the pin. The depthmeter will clearly indicate how far the pin has to go into the bone.

Ensure that both cortices are engaged; feeling the pin thread itself into the opposite cortex confirms correct insertion depth.

After the insertion of all pins, image intensification control in two planes is recommended. Conventional threaded pins should be bicortical so that the thread of the pin is fully threaded in the predrilled hole of the far cortex. The pins must not protrude too far since they would endanger the soft tissues.

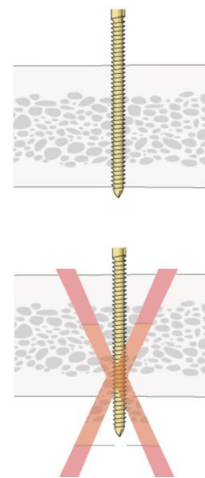

Frame Construction

Frame assembly

Connect the two pins of each main fragment to a bar using clamps.

The bar should lie close to the bone and the skin, but not so close as to risk pressure on the skin if the limb subsequently swells. There should be enough room between the bar and skin to allow cleaning.

Fully tighten the clamps to complete the two partial frames.

Connect the two partial frames with a bar using clamps applied loosely enough to allow reduction of the fracture.



Pitfall: Conflicting bars

The ends of the two bars should not be placed too close to each other as this could interfere with reduction.

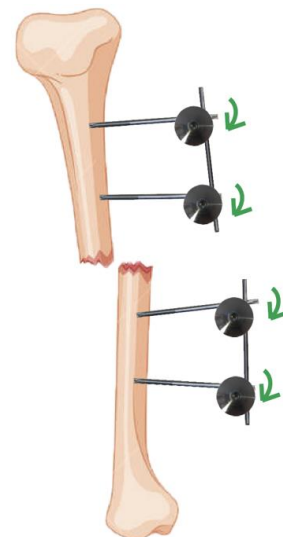

Reduction and Fixation

Alignment of the fracture

Using the partial frames as handles, manually reduce the fracture in length, rotation and axis. Check the provisional reduction in AP and lateral image intensifier views.

Note: As a planned temporary external fixator may turn out to be the definitive fixation, the fracture should always be brought out to length and reduced as accurately as is practical.

Fixation

When satisfactory reduction has been obtained, tighten the bar-to-bar clamps to finalize the frame construction. Reconfirm reduction using image intensification.

If additional stability is needed to secure the reduction, attach an additional bar (neutralization bar) to the two partial frames. This may be attached at each end to either a bar or a pin.

Periarticular injuries

When the fracture lies close to a joint it may be more practical to stabilize small periarticular fragments with a joint-spanning frame.

On principle this should be converted later to a form of fixation which allows the joint to move as soon as is practical, otherwise there is a risk of long-term stiffness.

Inspection and treatment of skin incisions

After the operation, stab incisions should be left open and treated locally with antiseptic dressings. Closing stab incisions prevents wound drainage, which increases the risk of pin tract infection.

If there is tension on one side, the incision should be extended. If significant extension is required so that the total incision is unnecessarily long the redundant portion of the incision may be closed.

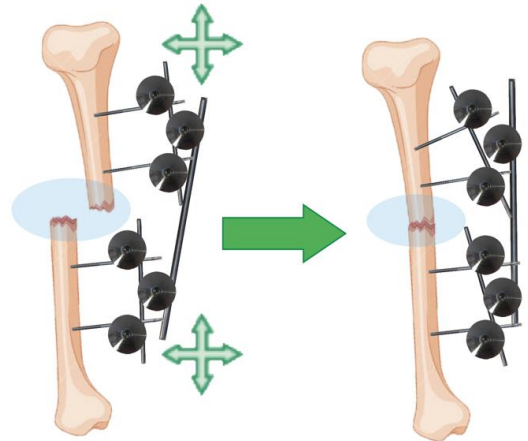

Subsequent Management after External Fixation as temporary fixation

If external fixation was used because the patient was not fit to undergo definitive internal fixation, once the general condition has improved, definitive fixation may then be considered.

Soft tissue healed

If the soft-tissue injuries have healed satisfactorily within 2 weeks without pin tract infection, the external fixation can safely be removed and replaced by internal fixation or a plaster of Paris if the pin sites are clean.

Soft-tissue problems persist

Soft-tissue problems persist

If there is pin tract infection, changing to a definitive internal fixation could lead to infection.

If the soft-tissue problems persist and/or the external fixator has been left on for 2 weeks or longer, or there are pin-tract infections the following steps should be taken:

- Remove the external fixator.
- Debride the pin sites in the operating theater, using curettage and irrigation, taking specimens for microbiological study.
- Temporarily stabilize in a splint or cast or place a new external fixator at new pin sites.
- Let the pin tracts heal.
- Put a new external fixation or proceed with internal fixation, covering with antibiotics, as necessary, and as determined by any positive microbiological cultures.

Pitfall: Intramedullary infection

If there is a pin-track infection, using an intramedullary nail (especially with reaming technique) could lead to intramedullary infection.

In this case plate osteosynthesis or continuing with a new external fixation with new pins at new positions may be preferable.

External Fixation as Definite Fixation

Indications

In the event that soft-tissue healing is not satisfactory after 4-6 weeks, and there is no pin-track infection, the external fixator can be left on until the fracture has healed.

In non-compliant patients the external fixator is often indicated as first and final treatment.

In children, fracture healing is often complete in 6-8 weeks. If external fixation is initially chosen, it should remain until fracture healing.

Adjusting the fixator

If a temporary fixator was initially applied rapidly when the patient was severely injured, once a decision has been made to continue external fixation as definitive treatment, it may be necessary to adjust the fixator to obtain more secure fixation. If necessary a new construct may be better able to maintain satisfactory reduction until the fracture has healed.

Optimal stiffness

A small amount of movement between the fracture fragments will stimulate callus formation. In highly fragmented fractures, movement is spread over the entire fracture area, but in simple, two-part fractures all movement occurs at only one fracture site.

Inadequate stability will delay fracture healing. However, beware of too much stiffness or rigidity, as this may also delay healing, especially in open fractures.

Pitfall: Pin loosening or pin-track infection

In case of pin loosening or pin-track infection, the following steps need to be taken:

- Remove all involved pins and place new pins in a healthy location.
- Debride the pin sites in the operating theater, using curettage and irrigation.
- Take specimens for a microbiological study to guide appropriate antibiotic treatment complementing the surgical debridement.

B

Harris profile three-way-clamp

	Hofman				Medic			
Bars	-2	-1	1	2	-2	-1	1	2
Cost								
Sterilization								
Stiffness								
Weight (8x300mm)								
X-ray compatibility								

	Hofman				Medic			
Clamps	-2	-1	1	2	-2	-1	1	2
Costs								
Stiffness								
# of Grooves								
Size								
Weight								
Component dependency ¹								
Disassembly								
Sterilization								
# of parts								
Spring mechanism								
Tightning mechanism								

¹ In case of emergency, how easy it is to replace a crucial component of the set

Drill	Hofman				Medic			
	-2	-1	1	2	-2	-1	1	2
Costs								
Automated included								
Hand Drill included								<input type="checkbox"/>
Sterilization								
Drill components								
Power supply								

Set	Hoffmann				Medic			
	-2	-1	1	2	-2	-1	1	2
Identification of parts								
Assembling during operation								
Clear instruction manual								
Complexity of instruction manual								
Number of parts								

Requirements weighing of the three-way-clamp

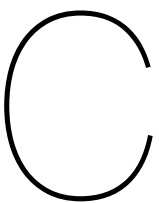

Clamps	Weighting Bars	Weighting Drill	Weighting Set	Weighting
Costs	3 Cost	3 Costs	3 Identification of parts	2
Stiffness	2 Sterilization	2 Automated included	1 Assembling during operation	1
# of Grooves	2 Stiffness	2 Hand Drill included	1 Clear instruction manual	2
Size	1 Weight	1 Sterilization	1 Complexity of instruction manual	2
Weight	1 X-ray compatibility	0,5 Drill components	1 Number of parts	1
Component dependency	2	Power supply	1	
Disassembly	1			
Sterilization	2			
# of parts	1			
Spring mechanism	1			
Tightening mechanism	1			

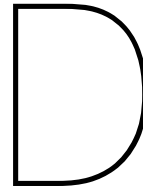

Patent search fix ex systems

System	Quantity	Specification	Material	Price (\$)
DePuy Large External Fixator	136	A broad variety of components, made out of titanium or stainless steel, connected to carbon fiber or SS bars.	Carbon fiber, SS, titanium	-
Globus Medical Arbor	76	A universal clamp made out of titanium, cobalt chromium or SS connects the carbonfiber bars to the pins. Also can be made use of a multiple-pin clamp.	Carbon fiber, cobalt chromium, SS, titanium alloy	-
Hoffmann 3 Stryker	130	A broad variation of clamps, pins and bars to fixate a broad range of fractures.	Aluminium, austenitic steel, carbon fiber, HA coated pins, vectran coated bars, titanium, SS	24532,00
Kyocera T710	-	The T710 External Fixator System consists of SS or titanium clamps, carbon fiber rods, and SS or titanium pins that provide the surgeon a broad range of frame construct options for stabilizing or immobilizing fractures.	Carbon fiber, SS, titanium	-
Linear model Rijcken	15	A multi-pin clamp connects the pins to the bar. Bars can be connected with the bar-bar clamps to establish a unilateral fixation. All SS, drill is optional	SS	285,27
MJ Surgical	17	A variety of stainless steel clamps are used to assemble the construction. This set contains 8 pins, 6 clamps, 3 bars. More clamp options are available.	SS	55,39
Modular model MEDIC Set	20	A bilateral fixation can be obtained by making use of this system, containing only SS materials. Pin-bar clamps and bar-bar clamps are used.	SS	382,90
OIC	-	A aluminium and titanium containing universal clamp or multiple pin clamp can be used. Carbon fiber bars connected by the clamps fixate the SS pins	Aluminium, carbon fiber, SS, titanium	-
Pro motion - Orthofix	19	Titanium clamps are connected to aluminium or carbon fiber bars. Pins can be delivered in SS or titanium. A sterile kit is delivered.	Aluminium, carbon fiber, SS, titanium	4241,46
Samay Surgical	17	Stainless steel set, consisting of 8 screws, 3 connecting bars, and 6 clamps	SS	79,00
Zimmer Fastframe	10	A single-use EF consisting of the following components that are manipulated by the end user: clamps, telescoping rods, and half-pin bone screws.	-	-
Zimmer Xtrafix	10	Aluminium clamps are used to connect the SS half pins to carbon fiber or glass fiber bars. Also can be made use of a multiple-pin clamp made out of aluminium.	Aluminium, carbon fiber, glass fiber, SS	-

[MJ Surgical](#)

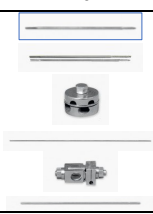
System	Part	Quantity	Specification	Material	Unit Price		Cumulative		Image
					min USD	max USD	min USD	max USD	
	Bone screw	4	Schanz Screw (pre-drill)	SS	0,45	0,8	1,8	3,2	
		4	Schanz Screw (self-tap)	SS	1,82	2,05	7,28	8,2	
	Universal clamp	4	Asculap clamp	SS	6,36	6,36	25,44	25,44	
	Steel rod	2	Connecting bar 4mm		0,8	1,02	1,6	2,04	
	Universal clamp	2	Adjustable clamp	SS	3,64	6,82	7,28	13,64	
	Steel rod	1	Tube 11mm		2,05	2,87	2,05	2,87	
MJ Surgical		17	A variety of stainless steel clamps are used to assemble the construction. This set contains 8 pins, 6 clamps, 3 bars. More clamp options are available.	SS			45,45	55,39	

[Samay Surgical](#)

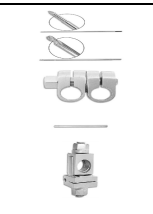
System	Part	Quantity	Specification	Material	Unit Price		Cumulative		Image
					min USD	max USD	min USD	max USD	
	Bone screw	4	Schanz Screw (pre-drill)	SS	2	2,5	8	10	
		4	Schanz Screw (self-tap)	SS	4	5	16	20	
	Rod-rod	4	Rod-rod clamp	SS	3	4	12	16	
	Steel rod	2	Connecting rod	SS	0,8	1	1,6	2	
	Universal clamp	2	Single adjustable Clamp	SS	5,5	13	11	26	
	Steel rod	1		SS	2	5	2	5	
Samay Surgical		17	Stainless steel set, consisting of 8 screws, 3 connecting bars, and 6 clamps	SS			50,60	79,00	

[Zimmer Xtrafix](#)

System	Part	Quantity	Specification	Material	Unit Price		Cumulative		Image
					min USD	max USD	min USD	max USD	
	Pin-bar clamp		6-, or 11mm pin-bar clamp	Aluminium			0	0	
	Multi-pin clamp	4	45mm, 1-bar multi-pin clamp	Aluminium			0	0	
	Half pins	4	Self-tapping pin, Step up feature allows pins in each system to be used with all the clamps in their respective systems	SS			0	0	
	Connecting bar	2	Free with clamp	Glass fiber, carbon fiber			0	0	
Zimmer Xtrafix		10	Aluminium clamps are used to connect the SS half pins to carbon fiber or glass fiber bars. Also can be made use of a multiple-pin clamp made out of aluminium.	Aluminium, carbon fiber, glass fiber, SS			0	0	

[Zimmer Fastframe](#)

System	Part	Quantity	Specification	Material	Unit Price		Cumulative		Image
					min USD	max USD	min USD	max USD	
	Fast frame	1	A single-use EF consisting of the following components that are manipulated by the end user: clamps, telescoping rods, and half-pin bone screws.				0	0	
	Bone screw	4	5x200x65mm threaded pins				0	0	
	T-handle	1	T-handle driver				0	0	
	Sleeve assembly	2	Tissue sleeve assembly				0	0	
	Lockout tab	2	Lockout tab				0	0	
Zimmer Fastframe		10	A single-use EF consisting of the following components that are manipulated by the end user: clamps, telescoping rods, and half-pin bone screws.				0	0	





[Globus Medical Arbor](#)

System	Part	Quantity	Specification	Material	Unit Price		Cumulative		Image
					min USD	max USD	min USD	max USD	
1173,0001	Universal clamp	16	Bar-to-bar, bar-to-pin, one clamp for all 3-6mm pins	Titanium alloy, cobalt chromium, SS			0	0	
X173.2200	Bone screw	36	Self-drilling, blunt tip schanz pin, transfix, including depth indicator	Cobalt chrome, titanium or SS			0	0	
1173,0006	Multi-pin clamp	4	Multi pin clamp allowing fixation of multiple pins at 90 degree	Titanium alloy, cobalt chromium, SS			0	0	
5173,1111	Connecting bar	12	11mm, 100-650mm length	Carbon fiber			0	0	
1173,003	Post	8	30° clamp post				0	0	
6173,2006	Drill guide handle	3	Drill guide handle, 6 holes				0	0	
6173,5065	Drill guide	9	Drill guide, 5x65mm, 5x115mm, 6x115mm				0	0	
6173,5075	Trocar		Trocar, 5x65mm, 5x115mm, 6x115mm				0	0	
6173,1503	Drill bit		3-6mm drill bits				0	0	
6173,9000	T-handle		T-handle 3 Jaw Chuck				0	0	
6173,0111	Multi-Tool						0	0	
630,4070	Silicone Ratcheting Handle		Silicone Ratcheting Handle				0	0	
6173,0112	Wrench		Combination and ratcheting wrench				0	0	
6173,9111	Snap Distractor		Snap Distractor, left-right				0	0	





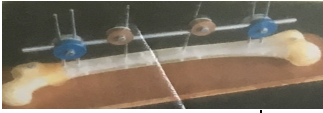

					0	0	
Globus Medical Arbor	76	A universal clamp made out of titanium, cobalt chromium or SS connects the carbonfiber bars to the pins. Also can be made use of a multiple-pin clamp.	Carbon fiber, cobalt chromium, SS, titanium alloy		0	0	

Stichting MEDIC



Linear model Rijcken



























System	Part	Quantity	Specification	Material	Unit Price		Cumulative		Image
					min USD	max USD	min USD	max USD	
	Bar-bar clamp	2	Bar-to-bar clamp	SS	13,5	13,5	27	27	
	Multi pin clamp	2	Multiple pins connected to connecting bar	SS	13,5	13,5	27	27	
	Bone screw	6	4-, 5mm	SS	15,36	20,44	92,16	122,64	
	Connecting bar	2	8mm, 40cm	SS	4	4	8	8	
	Drill	1	Battery drill, POWX0042LI		85	85	85	85	
	Drill mold	1	Drill mold		7	7	7	7	
	Ring spanner	1	Ring spanner		8,63	8,63	8,63	8,63	
							0	0	
Linear model Rijcken		15	A multi-pin clamp connects the pins to the bar. Bars can be connected with the bar-bar clamps to establish a unilateral fixation. All SS, drill is optional	SS			254,79	285,27	

Modular model MEDIC Set







System	Part	Quantity	Specification	Material	Unit Price		Cumulative		Image
					min USD	max USD	min USD	max USD	
	Universal clamp	6	pin-to-bar clamp	SS	13,5	13,5	81	81	
	Multi pin clamp	2	Multiple pins connected to connecting bar	SS	13,5	13,5	27	27	
	Bone screw	0	4mm	SS	15,36	15,36	0	0	
	Bone screw	6	5mm	SS	20,44	20,44	122,64	122,64	
	Connecting bar	2	8mm, 40cm	SS	4	4	8	8	
	Drill	2	8mm, 20cm	SS	17,5	17,5	35	35	
	Drill	1	Battery drill		85	85	85	85	
	Other parts	1	ring spanner, drill mold		24,26	24,26	24,26	24,26	
							0	0	
Modular model MEDIC set		20	A bilateral fixation can be obtained by making use of this system, containing only SS materials. Pin-bar clamps and bar-bar clamps are used.	SS			382,90	382,90	

[Hoffmann 3 Stryker](#)

System	Part	Quantity	Specification	Material	Unit Price		Cumulative		Image
					min USD	max USD	min USD	max USD	
49222020	Pin clamp	8	4-, 5-, 6mm pin clamp	Aluminium, austenitic steel and titanium	350	0	2800	0	
49222240	Pin clamp	2	30° 2 post pin clamp, 4-, 5-, 6mm	Aluminium, austenitic steel and titanium	460	0	920	0	
49222320	Pin clamp	2	Straight 1 post pin clamp, 4-, 5-, 6mm	Aluminium, austenitic steel and titanium	405	0	810	0	
49222120	Post	4	Straight post, 11mm		55	0	220	0	
49222140	Post	8	30° post, 11mm		55	0	440	0	
49222160	Post	2	90° post, 11mm		55	0	110	0	
50570300	Drill brace	1	Drill brace assembly apex		743	0	743	0	
50570310	Handle drill brace	1	Handle drill brace apex		103	0	103	0	
50305250	Bone screw	4	Steinmase 4-, 5mm		50	0	200	0	
50852045	Bone drill	1	High performance bone drill, 4.5 x 200 mm		79	0	79	0	
50852040	Bone drill	1	High performance bone drill, 4.0 x 200mm		79	0	79	0	
50852032	Bone drill	1	High performance bone drill, 3.2 x 200mm		71	0	71	0	
50185200	Bone screw	8	5mm, 200 x 50mm	SS, titanium, HA coating (optional)	38	0	304	0	
50186180	Bone screw	8	5mm, 180 x 50mm	SS, titanium, HA coating (optional)	38	0	304	0	
50185150	Bone screw	8	5mm, 150 x 40mm	SS, titanium, HA coating (optional)	37	0	296	0	
50233120	Bone screw	8	4mm, 120 x 30mm	SS, titanium, HA coating (optional)	33	0	264	0	
50574100	Predrilling assembly	2	4mm predrilling assembly		177	0	354	0	
50575100	Predrilling assembly	2	5mm predrilling assembly		177	0	354	0	

50576100	Predrilling assembly	2	6mm predrilling assembly		177	0	354	0	
50571004	Quick release chuck	1	Quick release chuck apex for 4mm pins		264	0	264	0	
50571005	Quick release chuck	1	Quick release chuck apex for 5mm pins		264	0	264	0	
50571110	Handle	1	Handle for guide block apex		362	0	362	0	
50271050	End caps	1	Disposable end caps apex 5mm		10	0	10	0	
50571115	Guideblock predrilling assembly	1	Guideblock predrilling assembly apex		291	0	291	0	
49212080	Pelvic clamp	2	Pelvic clamp 4-6mm	Aluminium, austenitic steel and titanium	321	0	642	0	
49212060	Pin clamp	2	10 hole pin clamp 4-6mm	Aluminium, austenitic steel and titanium	560	0	1120	0	
49221010	Clamp rod-rod	12	Rod-rod clamp, 5, 8, 11mm	Aluminium, austenitic steel and titanium	340	0	4080	0	
49221020	Clamp pin-rod	6	Pin-rod clamp, 4,5, 6mm/ 5, 8, 11mm	Aluminium, austenitic steel and titanium	340	0	2040	0	
49221030	Clamp pin-rod	2	Inverted pin-rod clamp, 4, 5, 6mm/ 5, 8, 11mm	Aluminium, austenitic steel and titanium	340	0	680	0	
49209020	Removable thumbwheel	2	Removable thumbwheel 7, 5mm		47	0	94	0	
49209030	T-wrench	1	T-wrench/ pin driver 7, 5mm		356	0	356	0	
49209036	Wrench	1	Wrench		268	0	268	0	
49228150	Connection bar	2	11x150mm connection bar	Carbon fiber (optional: Vectran coated), SS, Aluminium	125	0	250	0	
49228200	Connection bar	2	11x200mm connection bar	Carbon fiber (optional: Vectran coated), SS, Aluminium	140	0	280	0	
49228250	Connection bar	2	11x250mm connection bar	Carbon fiber (optional: Vectran coated), SS, Aluminium	155	0	310	0	
49228300	Connection bar	4	11x300mm connection bar	Carbon fiber (optional: Vectran coated), SS, Aluminium	170	0	680	0	
49228350	Connection bar	2	11x 350mm connection bar	Carbon fiber (optional: Vectran coated), SS, Aluminium	185	0	370	0	
49228400	Connection bar	2	11x400mm connection bar	Carbon fiber (optional: Vectran coated), SS, Aluminium	200	0	400	0	
49228450	Connection bar	2	11x450mm connection bar	Carbon fiber (optional: Vectran coated), SS, Aluminium	215	0	430	0	
50288450	Connection bar	2	8x450mm connection bar	Carbon fiber (optional: Vectran coated), SS, Aluminium	185	0	370	0	
49210000	Dynamisation tube	1	20mm dynamisation tube		1032	0	1032	0	
49210015	Compression tube	1	Compression/distraction tube 20mm		476	0	476	0	
4922-1-025	Delta coupling	1	Delta Coupling, Pin-to-Rod, multiplanar, Ø5/8/11mm Rods and Ø4/5/6mm Apex Pins						
4922-1-015	Delta coupling	1	Delta Coupling, Rod-to-Rod, multiplanar, Ø5/8/11mm Rods and Ø5mm Apex Pins						
49211100	Clamp tube-rod	2	Clamp tube-rod 20mm/8mm		329	0	658	0	

Stryker - Hoffmann 3 130 A broad variation of clamps, pins and bars to fixate a broad range of fractures. Aluminium, austenitic steel, carbon fiber, HA coated pins, vectran coated bars, titanium, SS 24532,00

System	Part	Quantity	Specification	Material	Unit Price		Cumulative		Image
					min USD	max USD	min USD	max USD	
	Universal clamp		Both bar-bar as pin-bar fixation	Aluminium, titanium			0	0	
	Multiple pin clamp		5-hole/8-hole multi-pin clamp option with straight and bent posts	Aluminium, titanium			0	0	
	Pin		5mm self-taping half pins, blunt-tipped half pins or transfixing pins (4-5mm)	SS			0	0	
	Connecting bar		11mm connecting bars made of carbon fiber. Available in different lengths (150-600mm)	Carbon fiber			0	0	
	Posts		Straight or 30° angle post	Aluminium			0	0	
	Drill		3.2x165mm/4x200mm drill				0	0	

OIC 0 A aluminium and titanium containing universal clamp or multiple pin clamp can be used. Carbon fiber bars connected by the clamps fixate the SS pins Aluminium, carbon fiber, SS, titanium 0 0

Kyocera T710 External Fixator System

System	Part	Quantity	Specification	Material	Unit Price		Cumulative		Image
					min USD	max USD	min USD	max USD	
	Pin-bar clamp		Pin-bar fixation clamp	316 SS, titanium			0	0	
	Multiple pin clamp		5-hole multi-pin clamp	316 SS, titanium			0	0	
	Bar-bar clamp		Bar-bar fixation clamp	316 SS, titanium			0	0	
	Connecting bar			Carbon fiber			0	0	
	Pins		Trochar or self-drilling tip. Multiple diameter and length options.	316LVM SS, titanium			0	0	

The T710 External Fixator System consists of SS or titanium clamps, carbon fiber rods, and SS or titanium pins that provide the surgeon a broad range of frame construct options for stabilizing or immobilizing fractures.

Kyocera
T710

0

Carbon fiber, SS, titanium

0 0

DePuy Large External Fixator

System	Part	Quantity	Specification	Material	Unit Price		Cumulative		Image
					min USD	max USD	min USD	max USD	
390,008	Pin-bar clamp	8	Pin-bar clamp	Titanium			0	0	
390,005	Combination clamp	12	Combination clamp	Titanium			0	0	
390,002	Multi-pin clamp	6	4 or 6 position clamp	Titanium			0	0	
390,007	Rod-rod clamp	2	Rod-rod clamp	Titanium			0	0	
390,003	Rod Attachment	6	Rod Attachment for large Multi Pin Clamp	Titanium			0	0	
494,782-788	Schanz screws	18	Self-drill, 5-6mm, 100-250mm length	SS, titanium			0	0	
494,520-570	Schanz screws	18	Self-tapping, 5-6mm, 100-190mm length	SS, titanium			0	0	
393,101	Adapter	1	Adapter for SELDRILL Schanz Screw 4.0 mm				0	0	
393,103	Adapter	1	Adapter for SELDRILL Schanz Screw 5.0 mm				0	0	
393,104	Adapter	1	Adapter for SELDRILL Schanz Screw 6.0 mm				0	0	
393,400	Protective Cap	10	Protective Cap for Schanz Screws and Steinmann Pins 4.0 mm				0	0	
393,420	Protective Cap	10	Protective Cap for Schanz Screws and Steinmann Pins 5.0 mm				0	0	
321,160	Wrench	1	Combination wrench 11mm				0	0	
321,158	Wrench	1	Combination wrench 8mm				0	0	
392,963	Drill guide	1	Drill guide handle, 6 positions				0	0	
395,911	Handle	1	Handle for drill sleeve				0	0	
392,951	Drill sleeve	11	Short drill sleeve (4-6mm) short and long				0	0	
394,800-870	Connecting bar	28		Carbon fiber, SS			0	0	

DePuy Large
External
Fixator

136

A broad variety of components, made out of titanium or stainless steel, connected to carbon fiber or SS bars.

Carbon fiber, SS, titanium

0 0

Pro-motion - Orthofix

System	Part	Quantity	Specification	Material	Unit Price		Cumulative		Image
					min USD	max USD	min USD	max USD	
93010	Large Clamp	6	Galaxy large clamp	Titanium	341,38		2048,28	0	
932150	2x Galaxy Rod D12mm L150mm	2	Galaxy rod 12mm, 150mm	Aluminium, carbon fiber	292,92		585,84		
932300	1x Galaxy Rod D12mm L300mm	1	Galaxy rod 12mm, 300mm	Aluminium, carbon fiber	292,92		292,92		
911550	2xCaliber Bone Screw 150 x 50 Unster	2	Caliber bone screw 150x50	SS, titanium	100,27		200,54		
912650	2xCaliber Bone Screw 260 x 50 Unster	2	Caliber bone screw 260x50	SS, titanium	100,27		200,54		
11.137	1xScrew Guide 80mm	1	Screw guide 80mm		152,44		152,44		
11.138	1xDrill Guide 6 x 4.8mm	1	Drill guide 6x4.8mm		145,59		145,59		
11.00101	1xDrill Bit 4.8x180mm	1	Drill bit 4.8x180mm		85,16		85,16		
11.00201	Drill Bit 4.8 x 240mm (alternative for 11.00101)	1	Drill bit 4.8x240mm		85,16		85,16	0	
91150	1xUniv.T-wrench+Xcal.screwconnector	1	Universal T-wrench + Xcal.screwconnector		164,81		164,81	0	
91120	Hand drill (optional)	1	Hand drill		280,18		280,18	0	
	Multi-pin clamp						0	0	
							0	0	

Pro motion -
Orthofix

19

Titanium clamps are connected to aluminium or carbon fiber bars. Pins can be delivered in SS or titanium. A sterile kit is delivered.

Aluminium, carbon fiber,
SS, titanium

4241,46 0

Harris profile patent research

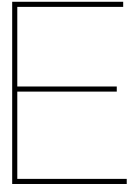



	Outcome					Functional Requirements																
	Application in DMCS					Cost	Ease of use		Versatility of constructs		Number of components		X-ray compatibility		Material selection		Sterilization					
	-2	-1	1	2		-2	-1	1	2	-2	-1	1	2	-2	-1	1	2	-2	-1	1	2	
External fixator systems																						
Modular model MEDIC Set																						
Unear model Rijkken																						
MyoSure																						
Stryker Surgical																						
Zimmer Fastframe																						
OIC																						
Pro motion - Orthofix																						
Kyocera T710																						
Globus Medical Arbor																						
DePuy Large External Fixator																						
Hoffmann 3 Stryker																						
Zimmer Xtrafix																						

Technical drawings

 TU Delft Delft University of Technology		name Clamp prototype, upper component		 material author Christiaan Horsman, 4952804		 units mm		scale 1:1		quantity 4		date 11/5/2020		remark Tolerance of: 1mm	
				6081-T6 (SS)		mass 12.28 gr		group TU Delft		format A4		drawing no. 1			

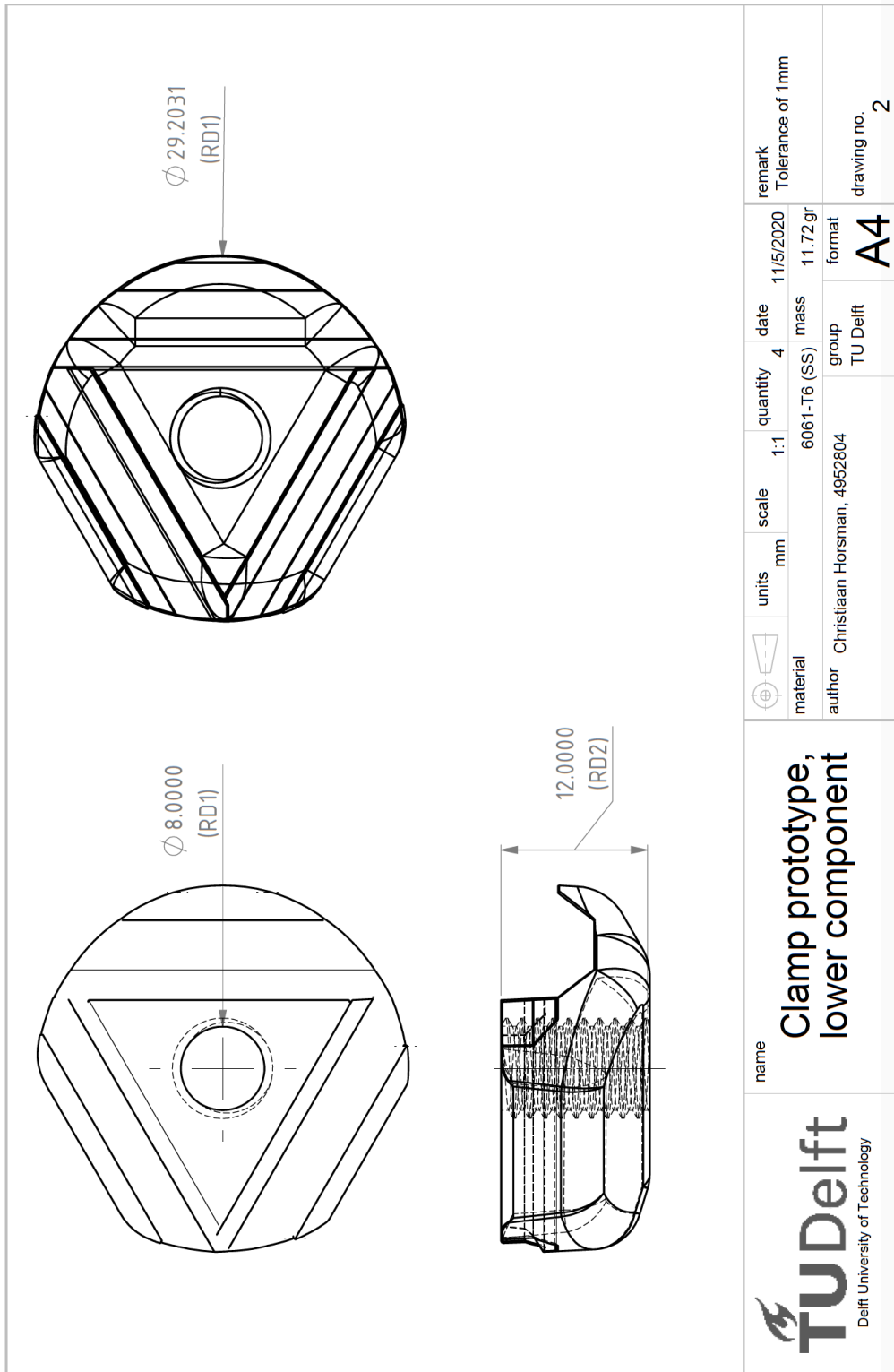
F



 material author Christiaan Horsman, 4952804	units	mm	scale	1:1	quantity	4	date	11/5/2020	remark	Tolerance of 1mm
	6061-T6 (SS)	mass	11.72gr	group	TU Delft	format	A4	drawing no.	2	

name
**Clamp prototype,
 lower component**



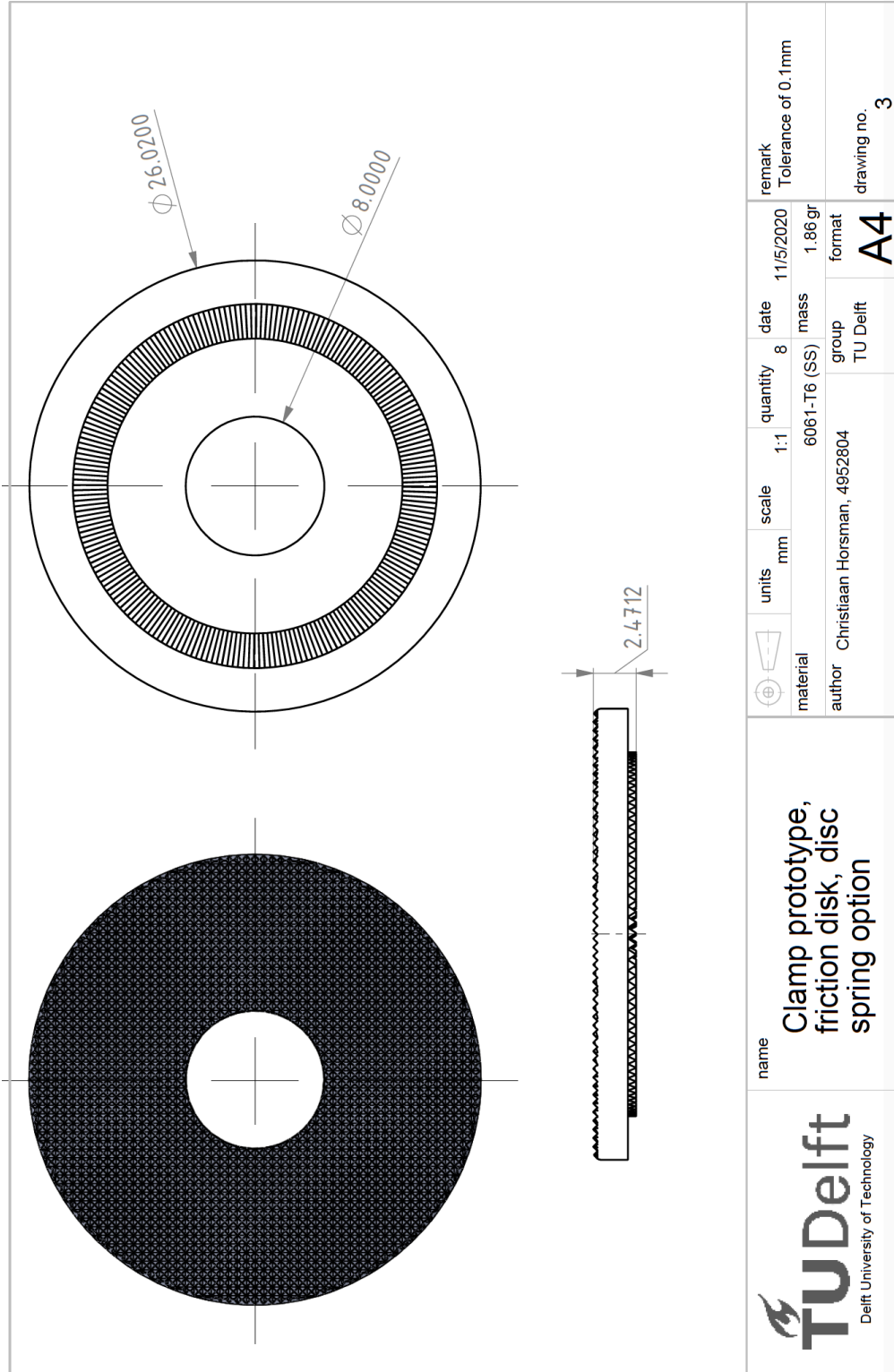

	units	mm	scale	1:1	quantity	8	date	11/5/2020	remark	Tolerance of 0.1mm	
	material	author	6061-T6 (SS)	Christiaan Horsman, 4952804	group	TU Delft	mass	1.86 gr	format	A4	
name Clamp prototype, friction disk, disc spring option										drawing no.	3





Thread engagement calculation

```
1 %% Thread calculation
2 % Christiaan Horsman, Biomedical Engineering
3 % 26/07/2020
4
5 %% Descriptives
6 At = 36.61;           % Tensile stress area
7 D = 8;               % Major diameter of fastener (screw)
8 p = 1/(1/1.25);     % 1/Number of threads per mm (mm)
9 Ts = 800;           % tensile strength of external thread material (screw
10 )
11 Th = 310;           % tensile strenght of internal thread material (hole)
12 %% Formula
13 Le = (2*At)/(0.5*pi*(D-(0.64952*p))) % Minimum thread engagement length
14 J = Ts/Th           % Thread engagement ratio
15 Le_adj = J*Le      % Adjusted thread engagement
16 length
```

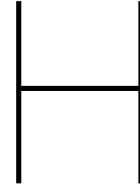
Matlab script slippage analysis

```
1 %% Mechanical testing Analysis: Prototype vs. Hoffmann 2
2 % Christiaan Horsman
3 % 28/10/2020
4
5 %% Script renewal
6 clear;
7 close all;
8 clc;
9
10 %% Data generation
11 str = 'cd~\Mechanical Analysis\Data\Horsman'; % Assign data string
12 folder_name = uigetdir(str); % folder_name
13 files = dir(fullfile(folder_name, '*.txt')); % Get files
14 curr_folder = pwd;
15 cd(folder_name);
16
17 for i = 1:length(files) % Import data files
18     [fid(i),msg] = importdata(files(i).name);
19 end
20 cd(curr_folder)
21
22 %% Calculation
23 % Calculation for maximum and minimum values
24 for i = 1:length(fid)
25     Max_N(i,1) = max(fid(i).data(:,2)); % Maximum load (N)
26     Min_N(i,1) = min(fid(i).data(:,2)); % Minimum load (N)
27     Mean_N(i,1) = mean(fid(i).data(:,2)); % Mean load(N)
28 end
29
30 % Calculation for indices of max and min values
31 Cell = zeros(length(fid),2); % Create zeros matrix
32 for i = 1:length(fid)
33     a = fid(i).data(:,1) ; % Time (ms)
34     a(:,2) = fid(i).data(:, 2) ; % Load (N)
35     [index, b]= find(a == max(a(:,2)) ) ; % Index determination
36     Cell(i,:) = a(index(1),:); % Create array with
37 end
38
39 %% Compute largest r in data
```



```
95 T.isdir = []; % Remove isdir column
96 T.datenum = []; % Remove datenum column
97 T.MaxLoad = Cell(:,2); % Add maximal load column
98 T.Time = Cell(:,1); % Add time column
99 T % Display table
100
101
102 %% Plot individual figure
103
104 for i=1:length(fid)
105     figure
106     Time = fid(i).data(:,1); % Assign time (ms)
107     FileName = files(i).name; % Assign filename to title
108     hold on
109     y = plot(Time, fid(i).data(:,2), 'b'); % Measured load
110     z = plot(Cell(i,1), Cell(i,2), 'r*'); % Maximum load
111     title(FileName) % Create title
112     ylabel('Force (N)') % Label y-axis
113     xlabel('Time (s)') % Label x-axis
114
115 end
```

Technical drawing testing fixture

 TU Delft Delft University of Technology		name Frame rvs clamp <small>H:\MY Documents\SolidWorks 2019\ISW Files\Thorlabs\</small>		 material author <<names & student numbers>>		 units mm		scale 1:1 Material <not specified>		quantity <<cnt>>		date 2-11-2020		remark <<remarks>>	
		mass 184.65 gr		group <<group>>		format A4						drawing no. <<drawing no.>>			

Bibliography

- [1] 3ERP. Aluminum cnc machine: Benefits and possible alternatives. <https://www.3erp.com/blog/aluminum-cnc-machine/>. (Accessed on 11/03/2020).
- [2] Anna Aimar, Augusto Palermo, and Bernardo Innocenti. The role of 3d printing in medical applications: a state of the art. *Journal of healthcare engineering*, 2019, 2019.
- [3] Unified Alloys. What is a pitting resistance equivalent number (pren)? <https://www.unifiedalloys.com/blog/pitting-resistance-pren/>. (Accessed on 09/30/2020).
- [4] Saleh S Altayyar. The essential principles of safety and effectiveness for medical devices and the role of standards. *Medical Devices (Auckland, NZ)*, 13:49, 2020.
- [5] ASM. Material data sheet. <http://asm.matweb.com/search/SpecificMaterial.asp?bassnum=MA6061T6>, . (Accessed on 10/28/2020).
- [6] ASM. Material data sheet. <http://asm.matweb.com/search/SpecificMaterial.asp?bassnum=MA6061T6>, . (Accessed on 11/02/2020).
- [7] The World Bank. Gni per capita, atlas method (current us\$) | data. <https://data.worldbank.org/indicator/NY.GNP.PCAP.CD>. (Accessed on 10/20/2020).
- [8] Michail Beltsios, Olga Savvidou, John Kovanis, Panagiotis Alexandropoulos, and Panagiotis Papegelopoulos. External fixation as a primary and definitive treatment for tibial diaphyseal fractures. *Strategies in trauma and limb reconstruction*, 4(2):81–87, 2009.
- [9] Christopher Bibbo and Jon Brueggeman. Prevention and management of complications arising from external fixation pin sites. *The Journal of foot and ankle surgery*, 49(1):87–92, 2010.
- [10] PTPW Burgers, MPJM Van Riel, LMM Vogels, Ronald Stam, Peter Patka, and EMM Van Lieshout. Rigidity of unilateral external fixators—a biomechanical study. *Injury*, 42(12):1449–1454, 2011.
- [11] Rodrigo Tavares Cardozo, Luís Gustavo Silva, Leandro Augusto Bragante, and Murilo Antônio Rocha. Treatment of fractures of the tibial diaphysis using external fixator compared with locked intramedullary nails. *Revista Brasileira de Ortopedia (English Edition)*, 48(2):137–144, 2013.
- [12] Jacob L Cartner, Warren O Haggard, Joo L Ong, and Joel D Bumgardner. Stress corrosion cracking of an aluminum alloy used in external fixation devices. *Journal of Biomedical Materials Research Part B: Applied Biomaterials: An Official Journal of The Society for Biomaterials, The Japanese Society for Biomaterials, and The Australian Society for Biomaterials and the Korean Society for Biomaterials*, 86(2):430–437, 2008.
- [13] Dimitri Ceroni, Catherine Grumetz, Odile Desvachez, Sophie Pusateri, Pierre Dunand, and Eleftheria Samara. From prevention of pin-tract infection to treatment of osteomyelitis during paediatric external fixation. *Journal of children's orthopaedics*, 10(6):605–612, 2016.
- [14] EY Chao, RA Kasman, and KN An. Rigidity and stress analyses of external fracture fixation devices—a theoretical approach. *Journal of Biomechanics*, 15(12):971–983, 1982.
- [15] Giovan Giuseppe Costa, Domenico Costantino Aloj, Simone Cerbasi, Maria Rizzo, Alessandro Massè, Raffaele Pascarella, and Massimo Mariconda. External fixation as a definitive treatment for humeral shaft fractures: radiographic and functional results with analysis of outcome predictors. *Journal of orthopaedic trauma*, 33(7):354–360, 2019.
- [16] Michael Cotton, Jaymie Ang Henry, and Lauren Hasek. Value innovation: an important aspect of global surgical care. *Globalization and health*, 10(1):1–5, 2014.

- [17] William W Cross III and Marc F Swiontkowski. Treatment principles in the management of open fractures. *Indian journal of orthopaedics*, 42(4):377, 2008.
- [18] Today's Medical Developments. Aluminum alloy ideal for a variety of applications. <https://www.todaysmedicaldevelopments.com/article/morris-technologies-alloy-6061-040912/>. (Accessed on 11/02/2020).
- [19] Matthew Dipaola. *3D printing in orthopaedic surgery*. Elsevier Health Sciences, 2018.
- [20] Abdel Rahim Elniel and Peter V Giannoudis. Open fractures of the lower extremity: Current management and clinical outcomes. *EFORT open reviews*, 3(5):316–325, 2018.
- [21] Carlos A Encinas-Ullán, José M Martínez-Diez, and E Carlos Rodríguez-Merchán. The use of external fixation in the emergency department: applications, common errors, complications and their treatment. *EFORT Open Reviews*, 5(4):204–214, 2020.
- [22] Field Fastener. Rules of thumb for thread engagement. <https://fieldfastener.com/2018/03/13/rules-of-thumb-for-thread-engagement/>. (Accessed on 11/06/2020).
- [23] FDA. Metals used in medical devices. <https://www.fda.gov/medical-devices/products-and-medical-procedures/metals-used-medical-devices>. (Accessed on 11/02/2020).
- [24] Nando Ferreira, Yashwant Singh Tanwar, Marilize Burger, et al. The effect of fixation dynamization on fracture healing: A systematic review. *Journal of Limb Lengthening & Reconstruction*, 6(1):7, 2020.
- [25] AO Foundation. Basic technique: Modular external fixation. <https://surgeryreference.aofoundation.org/orthopedic-trauma/adult-trauma/tibial-shaft/basic-technique/basic-technique-modular-external-fixation?searchurl=%2fSearchResults>, . (Accessed on 09/25/2020).
- [26] AO Foundation. External fixation for 22u-d/5 - ulna, complete oblique or spiral. <https://surgeryreference.aofoundation.org/orthopedic-trauma/pediatric-trauma/forearm-shaft/22u-d-5/external-fixation#principles-of-modular-external-fixation>, . (Accessed on 10/14/2020).
- [27] AO Foundation. Management of limb injuries, during disasters and conflicts. https://www.aofoundation.org/-/media/project/aocmf/aof/documents/icrc/a_field_guide_low_res.pdf, . (Accessed on 10/22/2020).
- [28] AO Foundation. Open fractures. https://www.aofoundation.org/-/media/project/aocmf/aof/documents/icrc/content-by-chapter/a-field-guide_chapter-08.pdf, . (Accessed on 10/05/2020).
- [29] Austin T Fragomen and S Robert Rozbruch. The mechanics of external fixation. *HSS Journal*, 3(1):13–29, 2007.
- [30] Robert S Gilley, Craig A Bourgeault, Larry J Wallace, and Joan E Bechtold. A comparative mechanical study of 3 external fixator clamps. *Veterinary Surgery*, 30(4):341–350, 2001.
- [31] N Giotakis and B Narayan. Stability with unilateral external fixation in the tibia. *Strategies in trauma and limb reconstruction*, 2(1):13, 2007.
- [32] Ramon B Gustilo and John T Anderson. Jsbs classics. prevention of infection in the treatment of one thousand and twenty-five open fractures of long bones. retrospective and prospective analyses. *The Journal of bone and joint surgery. American volume*, 84(4):682, 2002.
- [33] Andrew Hadeed, Ryan L Wertz, and Matthew Varacallo. External fixation principles and overview. In *StatPearls [Internet]*. StatPearls Publishing, 2019.
- [34] Takao Hanawa. Research and development of metals for medical devices based on clinical needs. *Science and technology of advanced materials*, 13(6):064102, 2012.

- [35] 3D Printing Industry. A high speed metal 3d printing technique from the university of sheffield. <https://3dprintingindustry.com/news/high-speed-metal-3d-printing-technique-university-sheffield-109513/>. (Accessed on 11/03/2020).
- [36] Health Information. How to sterilize medical equipment. <https://www.quickmedical.com/blog/post/how-to-sterilize-medical-equipment>. (Accessed on 11/02/2020).
- [37] Paley Orthopedic & Spine Institute. External fixator management. <https://paleyinstitute.org/patient-resources/patient-care-guides/external-fixator-management/#:~:text=Many%20patients%20are%20weight%2Dbearing,of%20the%20PAs%20after%20surgery>. (Accessed on 10/05/2020).
- [38] IntechOpen. Management of open fracture. <https://www.intechopen.com/books/trauma-surgery/management-of-open-fracture>. (Accessed on 10/22/2020).
- [39] Alberto Jorge-Mora, Samer Amhaz-Escanlar, Iván Couto González, Cristina López-Del Teso, Rodolfo Gómez, Teresa Jorge-Mora, José Ramón Caeiro-Rey, and Jesús Pino-Mínguez. Management of open fracture. *Trauma Surgery*, page 23, 2018.
- [40] Nikolas H Kazmers, Austin T Fragomen, and S Robert Rozbruch. Prevention of pin site infection in external fixation: a review of the literature. *Strategies in Trauma and Limb Reconstruction*, 11(2):75–85, 2016.
- [41] Kouamé Jean-Eric Kouassi, Olivier Cartiaux, Loic Fonkoué, Christine Detrembleur, and Olivier Cornu. Biomechanical study of a low-cost external fixator for diaphyseal fractures of long bones. *Journal of Orthopaedic Surgery and Research*, 15(1):1–8, 2020.
- [42] Rifat Latifi. *The Modern Hospital: Patients Centered, Disease Based, Research Oriented, Technology Driven*. Springer, 2019.
- [43] Lesjöfors. Technical information about springs. <https://www.lesjoforsab.com/technology/springs/>. (Accessed on 10/29/2020).
- [44] Lifebox. History of lifebox. <https://www.lifebox.org/history-of-lifebox-2/>. (Accessed on 10/26/2020).
- [45] Wei Liu, Lihui Yang, Xiaochuan Kong, Likun An, Gang Hong, Zicheng Guo, and Lei Zang. Stiffness of the locking compression plate as an external fixator for treating distal tibial fractures: a biomechanics study. *BMC musculoskeletal disorders*, 18(1):26, 2017.
- [46] JYC Lua, VH Tan, H Sivasubramanian, and EBK Kwek. Complications of open tibial fracture management: risk factors and treatment. *Malaysian Orthopaedic Journal*, 11(1):18, 2017.
- [47] E Lucarelli, M Fini, A Beccheroni, G Giavaresi, C Di Bella, NN Aldini, G Guzzardella, L Martini, A Cenacchi, N Di Maggio, et al. *Clin orthop relat res*. 2005.
- [48] Matmatch. Difference between aisi 316, 316l and 316ln stainless steel. <https://matmatch.com/learn/material/difference-between-aisi-316-316l-316ln-stainless-steel>. (Accessed on 09/29/2020).
- [49] John G Meara, Andrew JM Leather, Lars Hagander, Blake C Alkire, Nivaldo Alonso, Emmanuel A Ameh, Stephen W Bickler, Lesong Conteh, Anna J Dare, Justine Davies, et al. Global surgery 2030: evidence and solutions for achieving health, welfare, and economic development. *The Lancet*, 386(9993):569–624, 2015.
- [50] Jagdeep Nanchahal. *Standards for the management of open fractures of the lower limb*. Royal Society of Medicine Press Limited, 2009.
- [51] NCBI. External fixation principles and overview. <https://www.ncbi.nlm.nih.gov/books/NBK547694/>. (Accessed on 09/24/2020).

- [52] J Ni, H Ling, S Zhang, Z Wang, Z Peng, C Benyshek, R Zan, AK Miri, Z Li, X Zhang, et al. Three-dimensional printing of metals for biomedical applications. *Materials Today Bio*, 3:100024, 2019.
- [53] Norbar. Torque tension calculator. <https://www.norbar.in/Home/Torque-Tension-Calculator>. (Accessed on 11/06/2020).
- [54] Rele Ologunde, Mahiben Maruthappu, Kumaran Shanmugarajah, and Joseph Shalhoub. Surgical care in low and middle-income countries: burden and barriers. *International Journal of Surgery*, 12(8):858–863, 2014.
- [55] World Health Organization et al. Injuries and violence: the facts 2014. 2014.
- [56] Kathleen M O'Neill, Sarah LM Greenberg, Meena Cherian, Rowan D Gillies, Kimberly M Daniels, Nobhojit Roy, Nakul P Raykar, Johanna N Riesel, David Spiegel, David A Watters, et al. Bellwether procedures for monitoring and planning essential surgical care in low-and middle-income countries: caesarean delivery, laparotomy, and treatment of open fractures. *World journal of surgery*, 40(11):2611–2619, 2016.
- [57] Nihar R Padhi and Poonam Padhi. Use of external fixators for open tibial injuries in the rural third world: Panacea of the poor? *Injury*, 38(2):150–159, 2007.
- [58] ProLech. M8 inbusbout. <https://www.prolech.nl/webshop/ijzerwaren/bevestiging/inbusbouten/detail/2317/m8-inbusbout---8-x-50mm.html>. (Accessed on 10/28/2020).
- [59] Feng Qiao, Dichen Li, Zhongmin Jin, Yongchang Gao, Tao Zhou, Jinlong He, and Li Cheng. Application of 3d printed customized external fixator in fracture reduction. *Injury*, 46(6):1150–1155, 2015.
- [60] Buddy D Ratner, Allan S Hoffman, Frederick J Schoen, and Jack E Lemons. *Biomaterials science: an introduction to materials in medicine*. Elsevier, 2004.
- [61] Daniel Riedlbauer, Thorsten Scharowsky, Robert F Singer, Paul Steinmann, Carolin Körner, and Julia Mergheim. Macroscopic simulation and experimental measurement of melt pool characteristics in selective electron beam melting of ti-6al-4v. *The International Journal of Advanced Manufacturing Technology*, 88(5-8):1309–1317, 2017.
- [62] Ryerson. When and why to use aluminum 6061. <https://www.ryerson.com/resource/the-gauge/grade-anatomy-aluminum-6061>. (Accessed on 09/30/2020).
- [63] RM Sellei, P Kobbe, T Dienstknecht, P Lichte, R Pfeifer, M Behrens, S Brianza, and H-C Pape. Biomechanical properties of different external fixator frame configurations. *European Journal of Trauma and Emergency Surgery*, 41(3):313–318, 2015.
- [64] Mohammad Kamran Shahid and SA Malik. Review of the biomechanical role of a unilateral external fixator in the fracture repair process. *EC Orthop*, 3:3, 2016.
- [65] Di Shi, Kaiyuan Liu, Haomeng Zhang, Xinli Wang, Guochen Li, and Lianhe Zheng. Investigating the biomechanical function of the plate-type external fixator in the treatment of tibial fractures: a biomechanical study. *BMC Musculoskeletal Disorders*, 21(1):1–9, 2020.
- [66] Mark G Shrimme, Stephen W Bickler, Blake C Alkire, and Charlie Mock. Global burden of surgical disease: an estimation from the provider perspective. *The Lancet Global Health*, 3:S8–S9, 2015.
- [67] SMC. G-code and m-code: What do they mean in cnc machining? <https://www.steckermachine.com/blog/g-code-m-code#:~:text=Simply%20put%2C%20G%2Dcode%20is,a%20command%20for%20rapid%20movement>. (Accessed on 11/03/2020).
- [68] DA Spiegel, A Nduaguba, MN Cherian, M Monono, and ET Kelley. Deficiencies in the availability of essential musculoskeletal surgical services at 883 health facilities in 24 low-and lower-middle-income countries. *World journal of surgery*, 39(6):1421–1432, 2015.

- [69] David A Spiegel, Richard A Gosselin, R Richard Coughlin, Manjul Joshipura, Bruce D Browner, and John P Dormans. The burden of musculoskeletal injury in low and middle-income countries: challenges and opportunities. *JBJS*, 90(4):915–923, 2008.
- [70] Rachel V Thakore, Elvis L Francois, SK Nwosu, B Attum, PS Whiting, MA Siuta, MA Benvenuti, AK Smith, MS Shen, I Mousavi, et al. The gustilo–anderson classification system as predictor of nonunion and infection in open tibia fractures. *European Journal of Trauma and Emergency Surgery*, 43(5):651–656, 2017.
- [71] Filip Tomanec, Soňa Rusnáková, and Milan Žaludek. Optimization of the material of external fixator with fem simulation. In *Materials Science Forum*, volume 919, pages 275–281. Trans Tech Publ, 2018.
- [72] TRUMPF. Laser metal deposition (lmd). https://www.trumpf.com/en_SG/solutions/applications/additive-manufacturing/laser-metal-deposition-lmd/. (Accessed on 11/03/2020).
- [73] Karl T Ulrich. *Product design and development*. Tata McGraw-Hill Education, 2003.
- [74] David A Watters, Glenn D Guest, Viliami Tangi, Mark G Shrimel, and John G Meara. Global surgery system strengthening: it is all about the right metrics. *Anesthesia & Analgesia*, 126(4):1329–1339, 2018.
- [75] Tim Wehner, Lutz Claes, and Ulrich Simon. Internal loads in the human tibia during gait. *Clinical Biomechanics*, 24(3):299–302, 2009.
- [76] WHO. Injuries and violence - the facts. https://www.who.int/violence_injury_prevention/key_facts/VIP_key_facts.pdf. (Accessed on 10/20/2020).
- [77] Tak Man Wong, Jimmy Jin, Tak Wing Lau, Christian Fang, Chun Hoi Yan, Kelvin Yeung, Michael To, and Frankie Leung. The use of three-dimensional printing technology in orthopaedic surgery: a review. *Journal of Orthopaedic Surgery*, 25(1):2309499016684077, 2017.
- [78] Sven Young. Orthopaedic trauma surgery in low-income countries: follow-up, infections and hiv. *Acta Orthopaedica*, 85(sup356):1–35, 2014.
- [79] Yourdictionary. Corrosion resistance dictionary definition. <https://www.yourdictionary.com/corrosion-resistance#:~:text=The%20definition%20of%20corrosion%20resistance,thus%20able%20to%20withstand%20damage>. (Accessed on 09/30/2020).
- [80] Xia Zhao, Jianfeng Li, Ying Chen, Chunjing Tao, and Run Ji. Investigation of load transfer process between external fixator and bone model by experimental and finite element methods. *Journal of applied biomaterials & functional materials*, 17(1):2280800019826512, 2019.
- [81] Xia Zhao, Qufei Shi, Jingjing Li, and Jianfeng Li. Stiffness of a new unilateral external fixator—a biomechanical study. *Vibroengineering PROCEDIA*, 30:103–108, 2020.
- [82] Bruce H Ziran, Wade R Smith, Jeff O Anglen, and Paul Tornetta III. External fixation: how to make it work. *JBJS*, 89(7):1620–1632, 2007.