

## Review on Power Quality Issues in EV Charging

Qin, Z.; Wang, L.; Bauer, P.

**DOI**

[10.1109/PEMC51159.2022.9962952](https://doi.org/10.1109/PEMC51159.2022.9962952)

**Publication date**

2022

**Document Version**

Final published version

**Published in**

2022 IEEE 20th International Power Electronics and Motion Control Conference (PEMC)

**Citation (APA)**

Qin, Z., Wang, L., & Bauer, P. (2022). Review on Power Quality Issues in EV Charging. In *2022 IEEE 20th International Power Electronics and Motion Control Conference (PEMC)* (pp. 360-366). IEEE.  
<https://doi.org/10.1109/PEMC51159.2022.9962952>

**Important note**

To cite this publication, please use the final published version (if applicable).  
Please check the document version above.

**Copyright**

Other than for strictly personal use, it is not permitted to download, forward or distribute the text or part of it, without the consent of the author(s) and/or copyright holder(s), unless the work is under an open content license such as Creative Commons.

**Takedown policy**

Please contact us and provide details if you believe this document breaches copyrights.  
We will remove access to the work immediately and investigate your claim.

***Green Open Access added to TU Delft Institutional Repository***

***'You share, we take care!' - Taverne project***

**<https://www.openaccess.nl/en/you-share-we-take-care>**

Otherwise as indicated in the copyright section: the publisher is the copyright holder of this work and the author uses the Dutch legislation to make this work public.

# INVITED PAPER

## Review on Power Quality Issues in EV Charging

Zian Qin, Senior Member, IEEE, Lu Wang, Student Member, IEEE, Pavol Bauer, Senior Member, IEEE

**Abstract**— Electric vehicles (EVs) are playing a crucial role in achieving the carbon neutral goal. To make the charging experience comparable with the refueling of the gasoline cars, more and more chargers are installed and connected to the grid. Meanwhile, the charging power is going up. As a result, more and more power quality issues associated with EV charging events have already been reported. In this paper, the power quality issues that are relevant to EV charging, including flicker, harmonics, and supraharmonics, are summarized. Their generation mechanisms, harm to the grid, and the promising mitigation measures are discussed. Case studies are also done to mimic the power quality issues in EV charging, and verify the analysis.

**Keywords**—EV chargers, power quality, flicker, harmonics

### I. INTRODUCTION

The electrical mobility is essential in the energy transition. As the number of EVs on the road is increasing dramatically, immense EV chargers are being installed and connected to the grid. How to generate adequate electric power to fulfil the charging demand is one challenge; How to ensure a clean utility grid voltage with a huge amount of chargers starting up and shutting down all the time is another [1] [2] [3].

In fact, the PQ standards dedicated to the EV charging do not exist yet. As a compromise, the IEEE PQ standards and IEC 61000 series, are often referred to [1]. Nonetheless, a few power quality (PQ) issues associated with the EV chargers nearby, in terms of flicker, harmonics, supraharmonics, etc., have already been reported [4] [5] [6] [7]. The impact of EV charging on flicker has been investigated in [4], and it was found that the flicker issues are more prone to happen when the charging power per slot is going high. In [5], a group of EV chargers were tested and the results showed that almost all of them have considerable harmonics and supraharmonics emission. Moreover, it also showed that the emission level is related to the charging load. Supraharmonics are in a frequency range (2 kHz ~ 150 Hz) which was not problematic in the past, therefore no standards regarding supraharmonics exist yet [6]. However, as more and more power electronics are being integrated into the utility grid, supraharmonics are

This work has received funding from the Electronic Components and Systems for European Leadership Joint Undertaking under grant agreement No 876868. This Joint Undertaking receives support from the European Union's Horizon 2020 research and innovation programme and Germany, Slovakia, Netherlands, Spain, Italy.

becoming considerable and creating issues, e.g. the mal-operation of residual current devices (RCD) [8].

It is clear that the above mentioned power quality issues are induced by the interaction between EV chargers and the electric grid. However, in the analysis carried out in the literature, the chargers are often treated as a black box, and the dynamics of the chargers are usually not adequately modelled. To be more specific, regarding the flicker in EV charging, beside the charging power, the impact of the ramping up time of the charging, the short circuit ratio of the grid connection, and the X/R ratio of the grid impedance have been rarely discussed. Regarding the supraharmonics, as they are at kHz, it is straight forward to put the modulation of the power module in EV charger on doubt. However, the study on supraharmonics in the literature is often based measurements without analyzing the correlation between the supraharmonics and the modulation strategies.

The harmonics analysis is relatively more developed, partially because it is also requested in other power electronics dominated systems, e.g. wind farms, solar farms, microgrids, etc. Impedance-based approaches have become a norm in harmonic analysis of grid tied power electronics including EV chargers [9] [10] [11] [12] [13] [14]. Impedance-based stability criteria for grid tied power converters was proposed a decade ago [9], since then impedance-based approaches have gained a lot of attention. Grid imbalance has been taken into account in [10]. The impact of the active power filter was discussed in [12][13]. Input impedance modelling of EV chargers has been carried out in literature [15] [16]. Since the input impedance of EV chargers is also significantly affected by control parameters, it can be properly shaped for harmonics mitigation as well as stability enhancement [17]. Besides, the input impedance of EV chargers is also affected by the charging load, so an real-time charging navigation of EVs also has the potential for power quality issue mitigation [18] [19]. For long-term power quality evaluation, time variant impedance modelling was implemented in [14].

In this paper, the power quality issues in EV charging are thoroughly reviewed. More importantly, the modelling and analysis of different power quality issues are clearly discussed. Eventually, case studies are carried out to

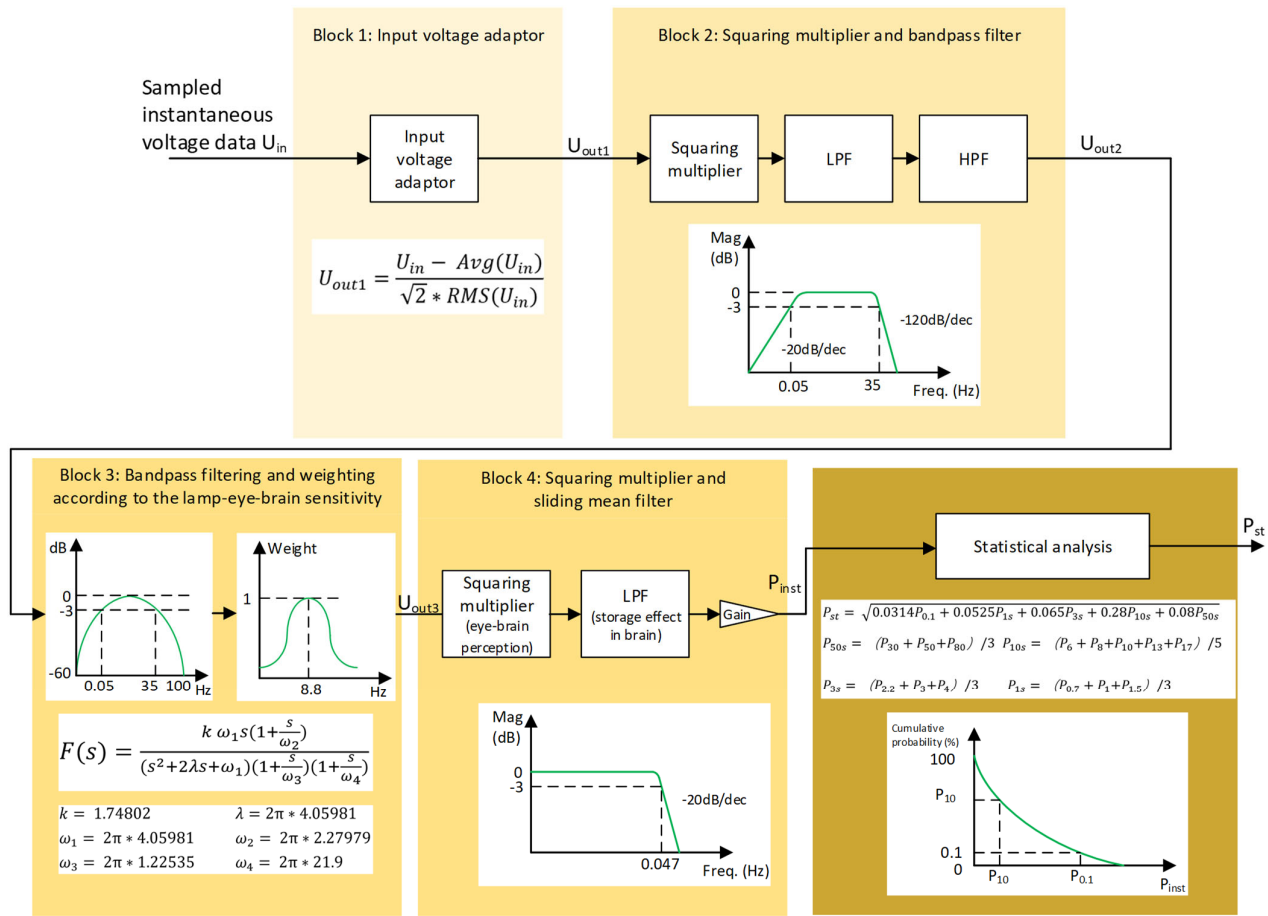

Fig. 1 The calculation procedure of flicker according to IEC 61000-4-15.

elaborate and verify the analysis. The rest of the paper is organized as following, Section II talks about flickers, Section III discusses about harmonics and interharmonics, Section IV analyzes supraharmonics, finally the paper is concluded in Section V.

## II. FLICKERS

The flicker in EV charging station can be analyzed by using the circuit model shown in Fig. 2. As seen, the charger is modelled as a time variant power load  $p_c(t)$ , while its dynamic caused by the filter and control loops are ignored.  $Z_g$  represents the grid impedance.  $v_g(t)$  depicts the grid voltage. The flicker issue is essentially the fluctuation of  $v_{pcc}(t)$ , caused by the charging load. When the fluctuation is beyond a certain limit, the lights that are connected to the same PCC will have a visible blink. Actually, in IEC 61000-4-15, flicker is not defined as a simple comparison between the voltage profile and a threshold. It is instead a summation of the probability of voltage fluctuations at different levels. As seen in Fig. 1, the impact of voltage profile on the flicker is quite nonlinear. Nonetheless, some regularity can be found, which will be elaborated as follows.

Fig. 2 shows that the voltage profile at PCC  $v_{pcc}(t)$  is co-affected by both the charging power profile  $P_c(t)$  and the grid

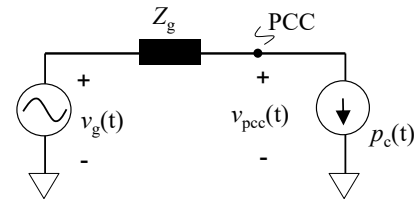

Fig. 2. A typical circuit model for flicker analysis.

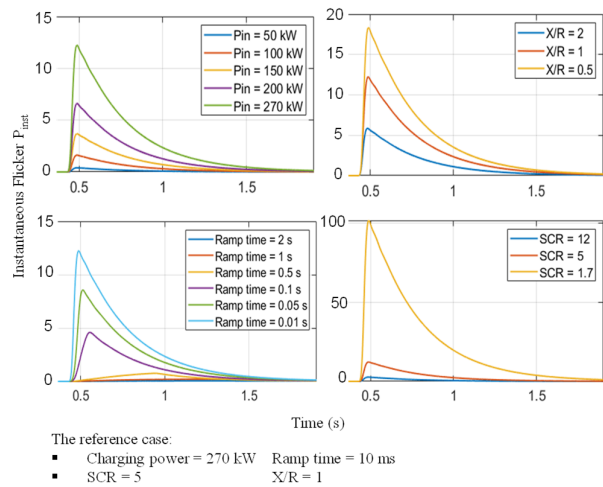

Fig. 3. The impact of influential factors on flicker.

impedance  $Z_g$ . The charging profile can deviate from one manufacture to another, as well as between different charging modes. However, the only influential part is the ramping up of the charging profile and its frequency. How the charging power will drop afterwards with how many steps does not matter. On the grid side, the short circuit ratios instead of the absolute grid impedance will influence the flicker. Moreover, the X/R ratio (the ratio between the reactance and resistance) of the grid impedance can also considerably affect the flicker.

Table I. Specifications of the grid connection.

Cable				
Model	Length	R	C	L
VG-YMvKrvas Dca 8,7/15 kV 172601	10 km	8 ohm	1.7 uF	4.09 mH
Transformer		Grid impedance at PCC		
Power rating	Short circuit impedance	Short circuit ratio	X/R ratio	
3.0 MVA	6%	3.82	0.4	

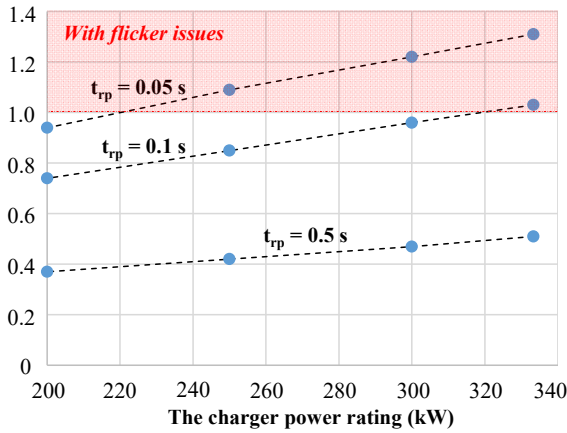

Fig. 4. Flicker  $P_{st}$  vs the power rating of the charger.

Fig. 3 shows all the impactful factors on instantaneous flicker ( $P_{inst}$ ), which is an intermediate parameter in the calculation of flicker, as depicted in Fig. 1. In general, the  $P_{inst}$  is higher when charging power is higher or the ramping up time is shorter. The  $P_{inst}$  is also affected by the grid impedance, and it increases as the grid is getting weaker or more resistive. Nonetheless, Fig. 3 does not give an intuitive insight into whether a series of charging events will end up with flicker or not. Therefore, a case study is done as follows. A 3.0 MVA fast charging station is taken as an example, which has a 10 kV medium voltage grid connection via a 10kV/400V transformer. To make it real, it is assumed that the charging station is aside a high way, and is connected to the feeder located 10 km away. More details of the grid connection are listed in Table I.

A 10 minutes simulation is carried out, where the power rating per charger is changed from 200 kW to 330 kW, and the ramping up time  $t_{rp}$  is changed from 0.05 s to 0.5 s. For simplification, it is assumed a charger is only started once in

10 minutes, and all the chargers in the 3.0 MVA station are started in the 10 minutes to mimic the worst condition. For instance, if the charger is rated at 300 kW, there will be 10 chargers in total. So every minute, a charger will be started. The results are shown in Fig. 4. As seen, when the ramping up time is 0.05 s, 250 kW per charging can already lead to flicker issues ( $P_{st} > 1$ ). However, when the ramping up time increases to 0.5 s, even 330 kW per charging will have flicker issues free. It should also be noted that if two charging events happen simultaneously, it will be more prone to have flicker issues. Considering the short ramping up time, this can rarely happen, but still there is a chance, for instance if the chargers are hacked and controlled by hackers.

### III. HARMONICS/INTERHARMONICS

In the grid code, harmonics are the positive integer multiple of fundamental frequency components in currents and voltages below 2 kHz. Those noises in the same frequency range, but have a non-integer multiple of the fundamental frequency, are named interharmonics. However, in this paper, it will be seen that the analysis of harmonics and interharmonics at PCC will follow the same approach.

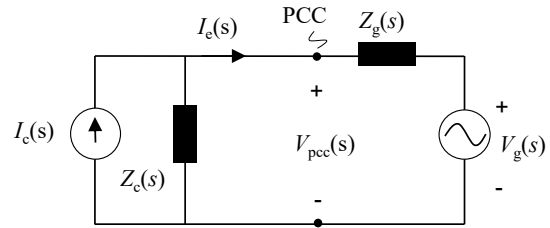

Fig. 5 An impedance-based model for harmonic analysis

To analyze the harmonic current emission at the PCC, the impedance-based approach is often used, as shown in Fig. 5. The grid is represented by the grid impedance  $Z_g$  at the PCC and the grid voltage background noise  $V_g$ , and the charger is modelled as a harmonic current source  $I_c$  and the input impedance  $Z_c$ . The model looks similar to the circuit model for flicker analysis. In fact, they are quite different. For harmonic analysis, the two impedances  $Z_g$  and  $Z_c$  should be accurate even at kHz. However, for flicker analysis, the grid impedance  $Z_g$  only needs to be accurate at the fundamental frequency, and the charger impedance is even neglected.

In case the charger has a modular design, the impedance of power modules can be easily aggregated to the impedance of the charger by neglecting the length and impedance of the short cable connecting the power modules. A similar procedure can also be followed for the aggregation from the impedance of a single charger to the impedance of the whole charging station.

On top of the impedance model, the harmonic current emission at the PCC can be calculated, as below,

$$I_e(s) = \frac{Z_c(s)}{Z_c(s) + Z_g(s)} I_{c,t}(s) - \frac{1}{Z_{c,t}(s) + Z_g(s)} V_g(s) \quad (1)$$

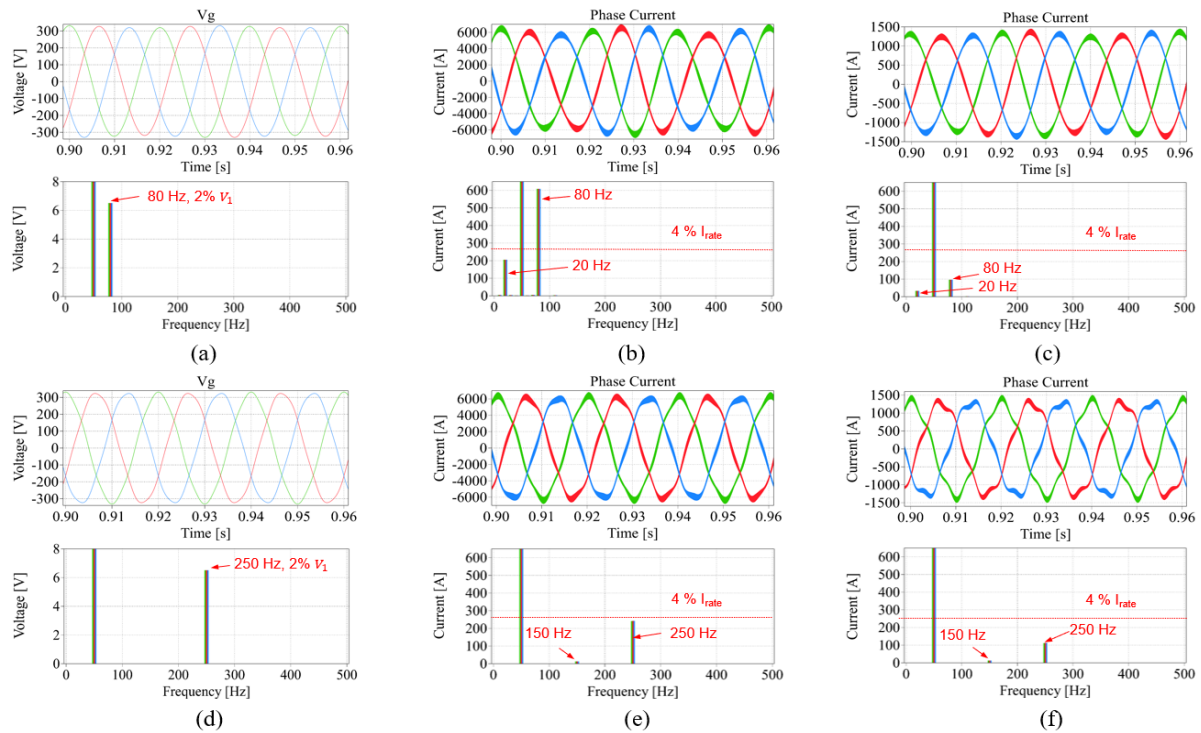

Fig. 6. Harmonic current emission in time and frequency domain of the fast-charging station in four scenarios. (a) and (d) show the grid voltages with a 2% interharmonics at 80-Hz and harmonics at 250-Hz, respectively. (b) and (e) show the currents at the PCC when ten chargers operate at the rated power with the grid voltages shown in (a) and (d), respectively. (c) and (f) shows the currents at the PCC when two chargers operate at the rated power with the grid voltages shown in (a) and (d), respectively.

where  $Z_{c,t}(s)$  is the impedance of the fast-charging station, and  $I_{c,t}(s)$  is the summation of the harmonic current generated by all chargers. As seen, the harmonic current emission at PCC is not simply a summation of the harmonic current emission of all the chargers in operation, but jointly affected by the harmonic current emission of each charger, the grid background harmonic voltage, and the impedance network as an amplification factor of the two emission sources. The two emission sources  $I_{c,t}(s)$  and  $V_g(s)$  usually fulfil the grid compliance. It is actually the impedance network and its amplification effect that make the harmonics at the PCC more complicated. The impedance based model is also valid in the analysis of interharmonics.

A case study is carried out for elaboration, where each 300-kW charger consists of ten 30 kW power modules. The design parameters of the active front end of the 30 kW power module are listed in Table II, and the grid condition is the same as depicted in Table I. Simulations are carried out in four scenarios, as elaborated in Fig. 6. As seen in Fig. 6 (b) and (e), even though the voltage noises are the same in terms of amplitude, the current emission at the PCC in Fig. 6 (b) is much higher. This can be explained by means of the impedance models. As seen in Fig. 7 (a),  $|Z_g + Z_{c,t}|$  has a much lower value at 80 Hz than 250 Hz. Thus, according to (1), the current emission at PCC will be larger when the grid voltage noise is at 80 Hz than 250 Hz. In Fig. 6 (c) and (f), the number of chargers in operation is changed from ten to two. Thereby the impedance of the charging station is also changed. This

Table II. Specifications of the active front end (AFE) of the 30-kW power module enclosed in the 300-kW EV charger

Symbols	Description	Value
$V_{dc}$	AFE output DC voltage	700 V
$E_g$	Grid phase voltage	230 Vrms
$f_1$	Grid frequency	50 Hz
$f_{sw}$	Switching frequency of AFE	40 kHz
$C_{out}$	Output capacitance of AFE	3 mF
$L$	Inductance of AFE power filter	250 $\mu$ H
$K_{ppll}$	Proportional gain of the PLL regulator	0.58
$K_{ipll}$	Integral gain of the PLL regulator	109.23
$K_{pi}$	Proportional gain of the current regulator	0.8
$K_{ii}$	Integral gain of the current regulator	100.53
$K_{pu}$	Proportional gain of the voltage regulator	0.5
$K_{iu}$	Integral gain of the voltage regulator	20

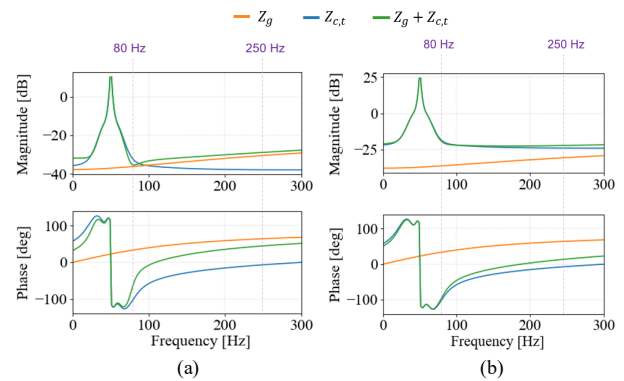

Fig. 7 Impedance of the grid (orange), fast charging station (blue), and network (green) when (a) 10 chargers operate at the rated power, and (b) 2 chargers operate at the rated power whereas the rest are disconnected from the grid.

TABLE III. HARMONIC CURRENT LIMITS IN IEEE-519 [1].

$I_{SC}/I_L$	Maximum harmonic distortion of the individual harmonic order in percent of $I_L$					
	$3 \leq h < 11$	$11 \leq h < 17$	$17 \leq h < 23$	$23 \leq h < 35$	$35 \leq h < 50$	TDD
$< 20$	4.0	2.0	1.5	0.6	0.3	5.0
$20 < 50$	7.0	3.5	2.5	1.0	0.5	8.0
$50 < 100$	10.0	4.5	4.0	1.5	0.7	12.0
$100 < 1000$	12.0	5.5	5.0	2.0	1.0	15.0
$> 1000$	15.0	7.0	6.0	2.5	1.4	20.0

Note:

- Limits for even harmonics are 25% of the odd harmonic limits
- DC offset in current is not allowed
- $I_L$ : maximum demand load current
- $I_{SC}$ : maximum short circuit current at PCC

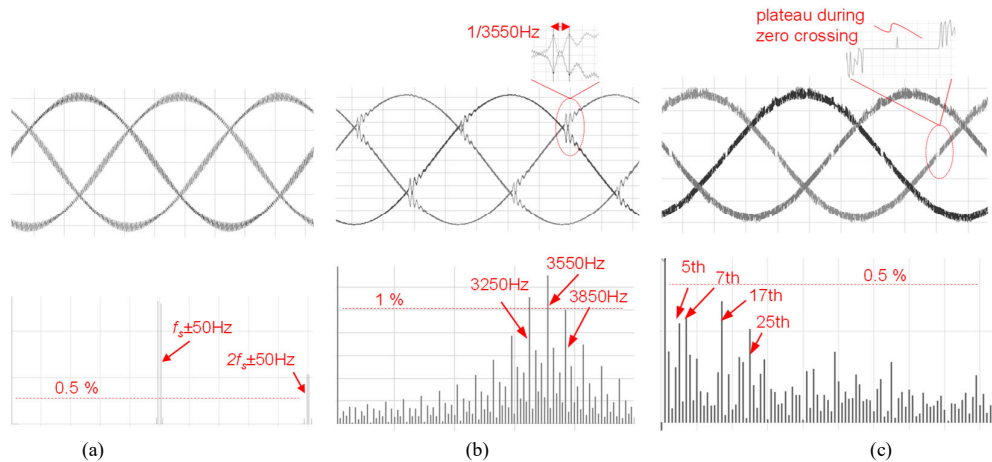

Fig. 9 The grid currents and their spectrums of (a) two level active rectifier (b) Swiss rectifier (c) Vienna rectifier

leads to a similar value of  $|Z_g + Z_{c,t}|$  at 80 Hz and 250 Hz. As a result, the current emissions at 80 Hz and 250 Hz induced by the voltage noise do not show a big difference in amplitude.

#### IV. SUPRA-HARMONICS

Supraharmonics are beyond 2 kHz, which therefore cannot propagate as far as low frequency harmonics in power lines. The grid network still provides a chance that several supraharmonics can make a superposition but can hardly be amplified, which despite can easily be the case in low frequency harmonics. Thus, the focus of supraharmonics is not the impedance modelling of the network, but rather the generation of them. The supraharmonics can clearly be generated by an action of a breaker or switching of a cable. Nonetheless, the continuous supraharmonics that become emerging topics and gained a lot of attention in recent years are from grid-tied power electronics, e.g. an EV charger.

One may wonder how come the chargers passed the grid compliance test, can still create supraharmonics when they are installed in the field. It is mainly because supraharmonics are in a frequency range, which rarely had problem in the past and thereby has been overlooked by the grid code, as shown in Table III, where the indication of the limits is only given up to 2.5 kHz. Supraharmonics have been reported in literature, mostly based on black box measurements of EV chargers, which does not give clear insight on how the charger design will influence the supraharmonics.

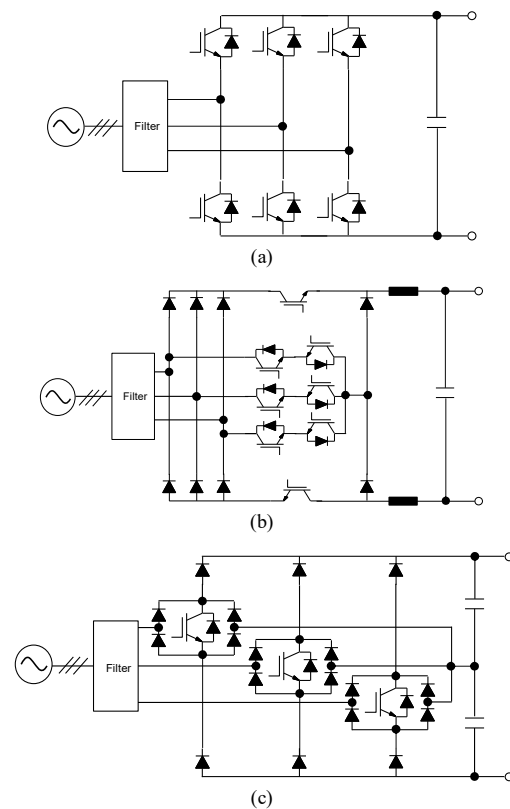

Fig.8 Typical topologies for medium and high power EV chargers. (a) two level active rectifier (b) Swiss rectifier (c) Vienna rectifier



Table IV. SUMMARY OF THE POWER QUALITY ISSUES ASSOCIATED WITH EV CHARGING.

	<b>Flicker</b>	<b>Harmonics/interharmonics</b>	<b>Supraharmonics</b>
<b>Frequency range</b>	Not defined, < 35 Hz [21] [22]	< 2 kHz	2 kHz~ 150 kHz
<b>Harm to grids</b>	flicker in Neighbour's lighting	<ul style="list-style-type: none"> <li>▪ power loss in cables and transformers</li> <li>▪ maloperation of current protection devices</li> <li>▪ induces voltage distortion of the grid</li> </ul>	<ul style="list-style-type: none"> <li>▪ maloperation of residual current detection (RCD) devices</li> </ul>
<b>Source of the noise</b>	<ul style="list-style-type: none"> <li>▪ starting of EV charging,</li> <li>▪ frequency beat between two chargers [21]</li> </ul>	<ul style="list-style-type: none"> <li>▪ under damped resonance in the grid-charger network</li> </ul>	<ul style="list-style-type: none"> <li>▪ modulation of EV chargers</li> <li>▪ commutation of switches in EV chargers</li> </ul>
<b>Mitigation measures regarding EV charging design</b>	<ul style="list-style-type: none"> <li>▪ limit the charging power ramping rate</li> <li>▪ avoid close switching frequencies between two neighbour chargers</li> </ul>	<ul style="list-style-type: none"> <li>▪ check the impedance matching between the chargers and grid, avoid underdamp resonance by tuning control loops</li> <li>▪ regulate the charging power properly to shape the charger's impedance</li> </ul>	<ul style="list-style-type: none"> <li>▪ grid code is missing.</li> <li>▪ variable switching frequency</li> <li>▪ sinusoidal carrier wave</li> </ul>

Several typical topologies for medium and high power EV chargers are therefore taken for investigation, as shown in Fig. 8. The Vienna rectifier is widely used because of its low cost and three voltage level feature. However, as a diode rectifier, it has current distortions during zero crossing, leading to low frequency harmonics in the grid currents, as shown in Fig. 9(c).

The Swiss rectifier has the similar feature as the Vienna rectifier, such as low cost and three voltage levels [20]. However, the commutation between the bidirectional switches creates high frequency ringing in the grid currents. According to the spectrum in Fig. 9 (b), the current ringing contains harmonics around 3550 Hz (71st), with an amplitude larger than 1% of the fundamental current. The two level active rectifier although is relatively more expensive, has the features like the reactive power controllability, bidirectional power flow capability, free of low frequency harmonics, etc. As seen in Fig. 9 (a), it can create switching frequency harmonics with considerable magnitude. Of course, the switching frequency harmonics in general exist in any topologies with a fixed switching frequency. It is negligible in the grid currents of the Vienna rectifier in Fig. 9 (c) because a hysteresis current control is used, which makes the switching frequency variable in a fundamental cycle, and thereby the switching frequency noises are distributed and become invisible in the spectrum.

It should be noted that, all the above EV chargers fulfil the TDD < 5%. Even though, as elaborated above, they may have considerable harmonics at switching frequency if a fixed switching frequency modulation is used, or at another medium frequency, e.g. the Swiss rectifier.

## V. CONCLUSIONS

Although EV chargers are power electronics based devices, they have unique features compared with other power electronics based equipment, like PV, wind turbines, etc. EV chargers are pulse load and usually connect in distribution

grids (more resistive). Thus, they are more prone to create flickers during starting up. The flicker can become worse due to the faster ramping up of the charging power, the higher charger power, the more often charging events, the weaker grid, and the more resistive grid. The mitigation measures from the charger design point of view include limiting the ramping rate of the charging power, the frequency of charging and especially the simultaneous starting up of several chargers.

Supraharmonics can also be generated by EV charging. Actually it can be created by all kinds of grid-tied power electronic converters. But it has been overlooked in the past and only gets considerable attention in recent years, because the supraharmonics induce disoperation of the RCD in distribution grids. Supraharmonics are high frequency harmonics, which are created by the modulation and switch commutation in the power electronics converters. As their frequency is high, the grid is mainly a damper to them. So the concern in mitigation measures is not the impedance match between the chargers and grid, but the attenuation of them in the charger, for instance by using variable switching frequency modulation, avoiding hard commutation, etc.

Harmonics and interharmonics can also be induced by EV charging. In principle, harmonics emission generated by the chargers should fulfil the grid code. However, due to the mismatch between the impedances of the chargers and grid, the harmonic currents from the charger and the background harmonic voltage from the grid can be amplified at PCC and break the grid compliance. Impedance modelling of the charger and grid are needed to analyze this phenomenon. Regarding the mitigation measures, a promising approach is to regulate the charging power to shape the charger's impedance, and match with the grid impedance properly. Table IV is a high level summary of the above elaboration.



## REFERENCES

- [1] L. Wang, Z. Qin, T. Slangen, P. Bauer, and T. van Wijk, "Grid Impact of Electric Vehicle Fast Charging Stations: Trends, Standards, Issues and Mitigation Measures - An Overview," *IEEE Open Journal of Power Electronics*, vol. 2, pp. 56–74, 2021.
- [2] C. H. Dharmakeerthi, N. Mithulananthan, and T. K. Saha, "Impact of electric vehicle fast charging on power system voltage stability," *International Journal of Electrical Power & Energy Systems*, vol. 57, pp. 241–249, 2014.
- [3] T. Thiringer and S. Haghbin, "Power quality issues of a battery fast charging station for a fully-electric public transport system in gothenburg city," *Batteries*, vol. 1, no. 1, pp. 22–33, 2015.
- [4] S. M. Alshareef and W. G. Morsi, "Impact of fast charging stations on the voltage flicker in the electric power distribution systems," in 2017 IEEE Electrical Power and Energy Conference (EPEC), 2017, pp. 1–6.
- [5] T. Slangen, T. van Wijk, V. Cuk, S. Cobben, "The Harmonic and Supraharmonic Emission of Battery Electric Vehicles in The Netherlands," 3rd International Conference on Smart Energy Systems and Technologies (SEST), 2020
- [6] S. K. Rönnerberg, M. H. J. Bollen, H. Amaris, et al., "On waveform distortion in the frequency range of 2 kHz–150 kHz—Review and research challenges," *Electric Power Systems Research*, vol 150, pp. 1–10, 2017.
- [7] T. Slangen, T. van Wijk, V. Cuk, S. Cobben, "The Propagation and Interaction of Supraharmonics from Electric Vehicle Chargers in a Low-Voltage Grid", *Energies*, 13, 2865, 2020.
- [8] Y. Xiang, V. Cuk, and J. F. G. Cobben, 'Impact of residual harmonic current on operation of residual current devices', in 2011 10th International Conference on Environment and Electrical Engineering, Rome, Italy, May 2011, pp. 1–4, doi: 10.1109/EEEIC.2011.
- [9] J. Sun, "Impedance-Based Stability Criterion for Grid-Connected Inverters," *IEEE Transactions on Power Electronics*, vol. 26, no. 11, pp. 3075–3078, Nov. 2011.
- [10] L. Beloqui Larumbe, Z. Qin, L. Wang and P. Bauer, "Impedance Modelling for Three-Phase Inverters with Double Synchronous Reference Frame Current Controller in the Presence of Imbalance," *IEEE Trans Power Electronics*, vol. 37, no. 2, 1461-1475, 2022.
- [11] D Vrec, L Beloqui Larumbe, Z Qin, P Bauer, BC Ummels, "Impact of WTG converter impedance model on harmonic amplification factor of the Dutch 110 kV transmission network using a 383 MW wind farm case study", *Cigre 2020 E-session*, 2020.
- [12] J Lei, Z Qin, W Li, P Bauer, X He, "Stability Region Exploring of Shunt Active Power Filters Based on Output Admittance Modeling," *IEEE TRANSACTIONS ON INDUSTRIAL ELECTRONICS*, vol. 68, no. 12, 11696-11706, 2021.
- [13] J. Lei, Z. Qin, W. Li, P. Bauer, and X. He, "Modelling of output admittance coupling between shunt active power filters and non-linear loads," in 2019 4th IEEE Workshop on the Electronic Grid (eGRID), 2019, pp. 1–5.
- [14] L Wang, Z Qin, LB Larumbe, P Bauer, "Python supervised co-simulation for a day-long harmonic evaluation of EV charging," *Chinese Journal of Electrical Engineering*, vol. 7, no. 4, 15-24, 2021.
- [15] B. Wen, D. Boroyevich, R. Burgos, P. Mattavelli, and Z. Shen, "Analysis of d-q small-signal impedance of grid-tied inverters," *IEEE Transactions on Power Electronics*, vol. 31, no. 1, pp. 675–687, 2016.
- [16] L Wang, Z Qin, LB Larumbe, P Bauer, "Multi-timescale Modeling of Fast Charging Stations for Power Quality Analysis," in 23rd European Conference on Power Electronics and Applications (EPE), pp. 1-9, 2021.
- [17] D. Yang, X. Ruan, and H. Wu, "Impedance shaping of the gridconnected inverter with lcl filter to improve its adaptability to the weak grid condition," *IEEE Transactions on Power Electronics*, vol. 29, no. 11, pp. 5795–5805, 2014.
- [18] J. Tan and L. Wang, "Real-time charging navigation of electric vehicles to fast charging stations: A hierarchical game approach," *IEEE Transactions on Smart Grid*, vol. 8, no. 2, pp. 846–856, 2017.
- [19] T. Zhao, Y. Li, X. Pan, P. Wang, and J. Zhang, "Real-time optimal energy and reserve management of electric vehicle fast charging station: Hierarchical game approach," *IEEE Transactions on Smart Grid*, vol. 9, no. 5, pp. 5357–5370, 2018.
- [20] T. B. Soeiro, T. Friedli and J. W. Kolar, "Swiss rectifier — A novel three-phase buck-type PFC topology for Electric Vehicle battery charging," 2012 Twenty-Seventh Annual IEEE Applied Power Electronics Conference and Exposition (APEC), 2012, pp. 2617-2624.
- [21] T. Keppler, N. R. Watson, J. Arrillaga and Shiun Chen, "Theoretical Assessment of Light Flicker Caused by Sub- and Interharmonic Frequencies," *IEEE Trans. on Power Delivery*, vol. 18, no. 1, pp. 329-333, Jan. 2003.
- [22] H. de Lange, "Research into the dynamic nature of the human fovea - > cortex systems with intermittent and modulated light. I. Attenuation characteristics with white and colored light," *J. Opt. Soc. Amer.*, vol. 48, no. 11, pp. 777-784, Nov. 1958.