

I A m H O M E

"Transforming an existing house
into a smart house
to provide for the well-being of its residents."

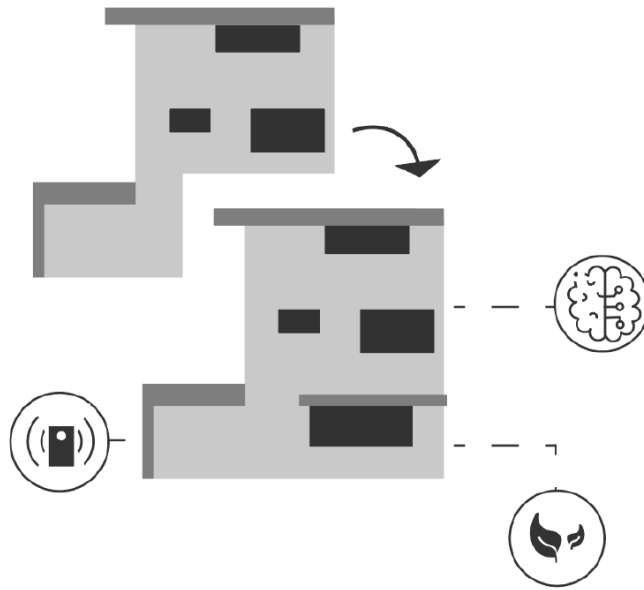

Master thesis report – Building Technology
Faculty of Architecture and the Built Environment

Delft University of Technology

Faculty of Architecture and the Built Environment
MSc Architecture, Urbanism and Building Sciences
Master Track Building Technology

Author

Name: Lena Balakina
Student number: 4592980

Graduation Committee

First mentor: Serdar Asut
Second mentor: Seyran Khademi
External Delegate: Dennis Pohl



ABSTRACT

This thesis investigates the transition of traditional houses into Smart Homes, emphasizing the improvement of residents' well-being, particularly for those aged 50 to 60. It is set against the rapid growth of Smart Home Devices enabled by the Internet of Things, facilitating easy control and monitoring of home features. There has been a significant increase in the market, with global shipments of such devices rising by 12% in 2021, reflecting a trend towards more connected and automated homes.

Smart Homes are becoming increasingly popular with people spending more time at home and the rise in digitalization. These homes represent technology and address the needs of an aging population, energy efficiency, and personal well-being enhancement. Yet, this shift to digital comes with challenges, including reliance on the internet and potential cybersecurity risks. The dissertation critically reviews these issues and looks at possibilities applied in the Built Environment.

Approaching the integration of Artificial Intelligence in the Built Environment, the study delves into the evolution from Smart Homes to Intelligent Homes. In this transition, AI plays a crucial role in creating environments that are adaptive and capable of making predictions. This shift towards more advanced technology raises important issues regarding privacy, ethical implications, and finding the right balance between convenience and security.

The research is driven by a detailed problem statement emphasizing the urgent need for innovative housing solutions in light of an aging society and healthcare system pressures. The case study developed in this thesis is in the Netherlands, where projections suggest that by 2035, over 24% of the population will be 65 and above. The study aims to transform an existing house into a Smart Home, focusing on improving indoor climate and resident well-being. Recognizing the subjective nature of health and well-being, it notes that the advantages of a Smart Home can differ among individuals. The study is significant for its potential contribution to the development of assistive technologies and services, ultimately seeking to improve life quality and support aging in place for future generations. With a combination of interdisciplinary fields such as Architecture and the Built Environment, design, and Artificial Intelligence, this thesis explored the possibilities for the future by taking a computational approach, including focusing on the indoor environment, comfort, and other things related to the technical aspect of the building.

Keywords: Smart Home, Intelligent Home, Adaptive façade, Kinetic façade, Kinetic shading system, Smart Home Devices, Intelligent Home Devices, Computational modeling, Python programming, Artificial Intelligence, Indoor Environment Quality, Indoor comfort

ACKNOWLEDGMENT

I sincerely thank my mentor, Serdar Asut, from the Building Technology department, for his support and valuable guidance throughout my research journey. His expertise in computational design has been crucial in navigating the complexities of this field, and I am immensely grateful for his patience and dedication.

I would also like to sincerely thank Seyran Khademi from the architecture department. Her insights into artificial intelligence and its applications in the built environment have opened my eyes to new possibilities and have significantly enriched my work.

Their collaborative efforts allowed me to bridge the gap between computational design and artificial intelligence, exploring innovative avenues in the built environment. I am thankful for the unique learning experience this has provided and the knowledge I have gained under their mentorship.

Additionally, I am grateful to my peers and colleagues for their support and encouragement in creating a stimulating and inspiring research environment.

Lastly, I thank my family, whose love and belief in me have been my constant source of strength and motivation.

ABBREVIATIONS

AI:	Artificial Intelligence
AIoT:	Artificial Intelligence and Internet of Things
BIM:	Building Information Model
HVAC:	Heating, Ventilation, and Air Conditioning
IAQ:	Indoor Air Quality
IEQ:	Indoor Environmental Quality
IHD:	Intelligent Home Device
IHDs:	Intelligent Home Devices
IoT:	Internet of Things
SDs:	Smart Devices
SH:	Smart Home
SHs:	Smart Homes
SHD:	Smart Home Device
SHDs:	Smart Home Devices
SHS:	Smart Home System
SHSs:	Smart Home Systems
SHT:	Smart Home Technology
SHTs:	Smart Home Technologies

CONTENT

I INTRODUCTION	10
1.1 Background	11
1.1.1 Upcoming Smart Homes	11
1.1.2 Modern life and digitalization	11
1.1.3 Critisizm of smart homes	12
1.1.4 Predictions for the future: from smart to intelligence	12
1.2 Problem Statement	13
1.3 Research Questions	14
1.4 Objectives and Limitations	15
1.4.1 Objectives	15
1.4.2 Limitations	15
1.5 Scope and Relevance	16
1.5.1 Scope	16
1.5.2 Relevance	16
1.6 Approach and Methodology	17
1.6.1 Approach	17
1.6.2 Methodology	17
1.7 Data collection and tools	18
1.7.1 Data collection	18
1.7.2 Tools	18
II LITERATURE REVIEW	20
2.1 Introduction to the State of the art	21
2.1.1 Digitalization, Internet of Things, and Smart Homes	21
2.1.2 Upcoming Smart Homes Devices	22
2.1.3 Difference between Smart and Intelligent	22
2.1.4 The need for Smart Homes in the future	24
2.1.5 Architectural and Engineering Inputs for a Smart Home within Smart Cities	25
2.2 Smart Homes, well-being, and indoor comfort	25
2.2.1 Well-being, Health, and Indoor Comfort	25
2.2.2 Different Perspectives on Artificial intelligence, Smart Homes, and well-being	27
2.2.3 Smart Home Devices and Indoor Comfort	29
2.3 Smart and Intelligent Building Components	30
2.3.1 Smart and Intelligent Façades	30
2.4 Smart Home Transformations	33

2.4.1 Smart home transformation	33
2.4.2 Smart Home Modification Process	35
2.4.3 Transforming smart homes into private diagnostic spaces	37
2.5 Privacy and Security Concerns	41
2.5.1 Challenges and issues of Implementing Smart Home Safety and Security System	41
2.5.2 Monitoring Security System	41
2.5.3 Privacy and security concerns	42
2.6 Market Analysis.....	44
2.6.1 Smart Homes Reference Projects	44
2.6.2 Classification of smart home technology	46
2.6.3 Smart Home devices on the market.....	47
2.6.4 Literature on smart home devices on the market	49
2.6.5 An Insight into the Smart Home Devices Market: <i>Interview with Signify</i>	55
2.7 Simulation tools	56
2.7.1 Smart Homes simulation tools.....	56
2.7.2 Smart Home Devices and Open API's	57
2.7.3 Smart Homes Raspberry Pi Home Automation System	57
2.7.4 Evaluation of Environmental Conditions Simulations	59
2.8 Conclusion.....	60
III CASE STUDY	62
3.1 Case study.....	63
3.1.1 Introduction and Design approach.....	63
3.1.2 Case Study Description.....	64
3.1.2 House and Climate Analysis.....	72
3.1.3 Design transformation based on analysis.....	84
3.1.3 Transformation shown in the layout	92
3.1.4 AI system integration to the Smart Home System.....	104
3.1.5 Climate Analysis After Transformation.....	107
3.2.1 Integration of the AI-Driven Control Systems in Real-life and Simulated Building Environments.....	110
3.2.2 From Design to Reality: Simulating Smart Home Systems with Home Assistant and YAML Coding	111
3.2.3 Prototype of the kinetic façade system	112
3.3 Conclusion.....	118

IV DISCUSSION, CONCLUSION AND REFLECTION	121
4.1 Discussion	122
4.2 Conclusion	123
4.3 Reflection	128
V REFERENCES	130
Bibliography:.....	131
VI APPENDICES	137
Appendix A: An Insight into the Smart Home Device Market: Interview with Signify.....	138
Appendix B: Climate Analyses	140
Appendix B: Honeybee Energy, cooling and heating load and Radiance analyses	144
Appendix D: Façade experiments kinetic shading system	146
Appendix E: Home Assistant Coding Operating System Smart Home Design	148
Appendix F: Prototype	166
Appendix G: Prototype Raspberry Pi code – Experiment 1	169
Appendix H: Prototype Raspberry Pi code – Experiment 2	172

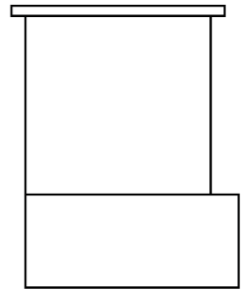

I INTRODUCTION

1.1 Background

1.1.1 Upcoming Smart Homes

Smart houses enable homeowners to control and monitor various aspects of their homes, such as lighting, climate, entertainment systems, alarm systems, and other applications. These devices are connected to the Internet of Things (IoT) to facilitate communication and functionality (Hayes, 2022). The IoT is a network of interconnected devices that communicate and share data, it is crucial for a Smart Home (SH) as it enables seamless control and monitoring of various household elements, fostering automation and responsiveness.

According to International Data Corporation (IDC), the market for Smart Home Devices (SHDs) has grown 12% worldwide in 2021 compared to 2020, with more than 895 million devices shipped (Needham, 2022). Smart Homes (SHs) are expected to surpass four hundred million by 2024. (Statista, n.d.) According to the Dutch Central Bureau of Statistics (CBS), more than eight out of 10 Dutch citizens aged 12 years or older have one or more smart devices or systems connected to the internet in their homes (CBS, 2022).

With such a significant rise in adoption, Smart Home Technology (SHT) is becoming integral to modern living. These devices offer homeowners control and the ability to gather data and insights on their living habits, enabling more personalized and efficient home management. As technology advances, a broader range of devices and applications are entering the market, including smart refrigerators that assist in managing groceries and advanced security systems offering real-time alerts and surveillance. SHT is reshaping the Built Environment, influencing residential design, construction, and operation. Architects and builders are embedding these technologies into homes, prioritizing connectivity and automation to create spaces that are intelligent, responsive, energy-efficient, and sustainable. This shift marks a significant transformation in home design, improving living standards and contributing to sustainable design.

1.1.2 Modern life and digitalization

Reasons why SHs are starting to be more popular these days, are because of the increment of the time that is spent at home, more people are more likely to upgrade their existing home, people are looking for ways to curb their energy usage, and seniors need their homes to do more for them (Hawkins, 2023). Many diseases for these seniors result from bad nutrition, lack of physical activity, anxiety, and depression. The category of people between 50 and 60 years in the Netherlands has an increase in diseases compared to other age groups (CBS, 2023). The quality and suitability of housing can affect the well-being of these people. If housing conditions are not conducive to a healthy lifestyle, it may contribute to both physical and mental health issues. Modern life has become rushed, and there is little time left for personal care, for example, the lack of sleep because of the endless possibilities of the internet, the blue light emitted on the screens, and the daily stress (Roeters, 2018). As the demand for personalized solutions to mitigate the effects of modern life grows, the integration of Smart Home Technologies (SHTs) emerges as a promising avenue, offering

automated features that can enhance sleep quality, reduce screen-related stress, and optimize daily routines. As modern life becomes increasingly digitalized, the adoption of SHT aligns seamlessly with our everyday routines and interactions. Digitalization has simplified our lives and work, making it easier to include smart devices in our homes. This thesis will explore the relationship between modern lifestyles, digitalization, and SHs, aiming to understand how these interconnected elements can enhance the well-being and convenience of residents.

1.1.3 Criticism of Smart Homes

Nevertheless, SHDs are upcoming; criticisms include high costs, dependence on the internet, and professionals. Another critical point is the threats from a cyber security perspective (Vrooman, 2017). The increase in connectivity within homes also presents potential challenges, particularly in terms of cybersecurity and data privacy. As more personal information is collected and shared between devices, ensuring the security of these networks is essential. Manufacturers, policymakers, and users alike need to be proactive in addressing these concerns to ensure that the SH ecosystem remains secure and trustworthy.

Furthermore, the integration of SHT is also highlighting issues of accessibility and digital literacy. With a significant portion of the population adopting these technologies, it is crucial that efforts are made to ensure that all individuals, regardless of their technical proficiency, can access and benefit from SHDs. This includes providing education and resources to help users understand and navigate these technologies effectively, promoting a more inclusive digital environment.

This thesis investigates the pros and cons of SHs, serving as a foundation before delving into the transformation of a house into a SH. By conducting a hypothetical transformation for a hypothetical resident in the case study, the intention is to gain insights into areas of potential improvement within these SH settings. Eventually, a step-by-step approach will be created to transform our current houses into smart houses to provide for the well-being of its resident. This can be done by creating a healthy indoor climate and, therefore promoting aging in place.

1.1.4 Predictions for the future: from smart to intelligence

The concept of SHs has been around since the 1960s when hobbyists were building "wired homes." The official term SHs was used in 1984 by the American Association of House Builders. Interactive technologies that were used in these houses were what made these homes called SHs (Harper, 2003). Even though SHs are a relatively new concept, the trajectory is shifting toward more intelligent homes with the rapid advancement of Artificial Intelligence (AI).

Over the years, the concept of SHs has evolved from basic remote control of home appliances to the creation of self-thinking homes capable of making autonomous decisions based on occupant guidelines. The integration of AI has been a game-changer in this field, bringing with it the ability to perform complex tasks such as reasoning, learning, and predicting user behavior. These capabilities are vital for creating intelligent environments that enhance convenience and energy efficiency and adapt and learn over time (Reaz, 2013).

Today's SHs focus on automation and remote control, striving to create sophisticated ecosystems that learn from user behavior, adapt to their preferences, and even predict their needs. Machine learning, data analytics, and predictive models are at the forefront of this transformation, enabling personalized living experiences like never before. However, ethical and privacy concerns have surfaced as these technologies become more embedded in our homes. Analyzing personal data within our living spaces necessitates carefully balancing convenience, personalization, and privacy protection.

Looking ahead, the trajectory of SHs is set toward creating even more intelligent and responsive living spaces. The future promises homes that anticipate our needs, respond to our moods and assist us in unexpected ways. This evolution from smart to intelligent homes marks a revolution in our interaction with our living spaces, by integrating technology into our daily lives and creating a new era of home living.

1.2 Problem Statement

The population is aging, and there needs to be more attention and resources in health care. The estimation for the Netherlands is that in 2035, over 24 percent of the population will be 65 years and older; currently, this is 20 percent (CBS, 2022). The life expectancy increased; the average age of death in the Netherlands was 71,4 years in 1950 and 81,4 years in 2021 (CBS, n.d.). With the aging population, the demand for nursing homes increases.

Elderly people have to take care of themselves increasingly, and waiting lists for nursing homes are growing daily (NOS, 2022). Older adults are increasingly likely to live alone or as part of a single-person household, which affects the demand for housing and healthcare services. There is a need for more flexible and adaptable housing options that can meet the changing needs of older adults, such as homes that can be modified for accessibility (Van der Staak et al., 2020).

Solutions in the Built Environment are needed to adapt to the future society and make aging in place more accessible and comfortable. SHTs and assistive devices can play a crucial role in making homes safer and more comfortable for older adults. Integrating these technologies can help monitor health, ensure security, and assist in daily activities. Addressing the challenges posed by the aging population in the Netherlands requires a multi-dimensional approach that encompasses health, housing, and technology.

1.3 Research Questions

Main question: “How can a house be transformed into a smart house to improve the well-being of its residents using smart devices and the help of artificial intelligence?”

To get the answer to this question, the following sub-questions need to be answered:

Sub Question 1: What is the state of the art regarding smart house devices and artificial intelligence used in the Built Environment?

Sub Question 2: How can a smart house change the spatial relationship and function in a house?

Sub Question 3: How can these smart and intelligent devices be implemented in the transformation of a smart house, and how will the architectural qualities of the house change?

Sub Question 4: What are the steps to transform our current houses into smart houses?

The background questions during this research are:

Background Question 1: What are the differences between smart and intelligent devices, and what are the expectations for the future?

Background Question 2: How does the surrounding of a house influence the transforming the house into a smart house?

Background Question 3: How does safety play a role in a smart house system?

Background Question 4: What are the options for using artificial intelligence regarding a smart house for the well-being of a resident?

Background Question 5: What benefits does a smart house system provide for the well-being of its resident?

Background Question 6: How can a grasshopper simulation help with the testing process in scenarios that are impossible to test in real life?

1.4 Objectives and Limitations

1.4.1 Objectives

Main Objective: Transform an existing house into a smart house to provide for the well-being of its resident.

Other objectives that will be achieved in this process are the following:

Sub Objective 1: Investigate the market and the state of the art of smart house devices, creating a list of the smart devices on the market and identifying the scale of how smart the devices are.

Sub Objective 2: Doing a simulation for this case study to measure the outcomes of the hypothetical transformation.

Sub Objective 3: Proposing a guideline to transform an existing house into a smart house.

1.4.2 Limitations

Health is a broad term and can be interpreted differently; since health varies per person, the outcomes for providing well-being are different for every individual case. Therefore, the study recognizes that the health benefits of a smart house would vary per person. The case study will be conducted objectively, focusing on the Building Technology component to relate it to the MSc Building Technology. The focus is placed on enhancing the indoor climate, which is a critical factor in the overall health and comfort of residents. Improving the indoor climate can vary per person due to individual differences in temperature preference, sensitivity to air quality, lighting needs, and personal comfort with the space around them. What feels comfortable for one person might not be the same for another, making personalization important in smart house settings.

Another limitation of this study is its dependence on simulations carried out using Ladybug Tools. Although these tools are advanced and commonly employed in Building Technology, they are inherently restricted by their preset configurations and algorithms. These simulations aim to model and predict outcomes based on various parameters, but they cannot encompass the full complexity of actual environments. Therefore, the simulated results provided in this research should be considered as estimates. The real-life performance of smart houses may deviate due to unpredictable factors that can affect the outcomes, for example differences in occupancy schedules in real life compared to pre-set occupancy schedules. Simulating the outcomes of a hypothetical transformation might not fully capture the complexities and nuances of real-world implementation, potentially affecting the reliability of the study's conclusions.

The discussion focuses on the reliability of simulation results without real-world validation. Ladybug tools' programs for residential settings are standardized but only capture some of the nuances of real life. Using these simulations as a preliminary tool for transformations is

beneficial to predict outcomes and evaluate changes in indoor comfort. For complete accuracy, real-life scenarios, which always vary, need validation. Installing devices in a house to track residential behavior and environmental conditions provides more accurate data regarding the house's usage.

Another crucial factor to consider is the swift evolution of the SH and AI fields and the changing residential needs. Recommendations and guidelines based on the current state of the market may become outdated quickly as new technologies emerge, potentially affecting the long-term relevance of the study's findings. The approach to transforming an existing house differs significantly from designing a smart home from scratch. When designing from the ground up, it is possible to tailor the home to specific user requirements, making the design more user-centric. This implies that the transformation applied in this case study may vary for another user under different circumstances in the future.

1.5 Scope and Relevance

1.5.1 Scope

The scope of this thesis is to explore and propose solutions for transforming an existing house into a smart house to improve the well-being of its residents, mainly focusing on individuals between 50 and 60 years old. By exploring solutions for this age group the thesis addresses the challenges of shortages in healthcare resources, an aging population, and the growing need for adaptable housing options. By integrating SH solutions and looking at smart devices and AI technologies, this research seeks to understand how the Built Environment can enhance the quality of life for this demographic.

1.5.2 Relevance

The relevance of this research is centered around improving the quality of life for individuals by introducing inventive approaches in the Built Environment and transforming the houses of ages between 50 and 60 years old to make them ready for the elderly stages. With the rise in the need for in-home care and the expansion of the elderly population, the importance of adaptable housing become crucial for ensuring comfort, accessibility, and good quality of life for the resident. This research aims to contribute to developing assistive technologies and services that support aging in place and enhance the future of society's well-being.

This research is highly relevant due to the widespread use of SHs and the digitization of our lives. It's especially applicable in the Netherlands, where many people are already familiar with using smart devices at home. The findings of this study will have implications not just in the Netherlands but around the world, considering the common issue of an aging population. The goal of this research is to turn homes into active supporters of health and well-being through smart technology. It aims to create homes that are more than just buildings, but intelligent spaces that know and respond to the needs of those living in them, helping residents to live independently and comfortably for longer.

1.6 Approach and Methodology

1.6.1 Approach

This research aims to tackle the challenges facing the Built Environment sector, the shortage of healthcare facilities, the aging population, and the inability of elderly individuals to care for themselves. The main objective is to find practical solutions by exploring the process of transforming existing houses into SHs that promote the well-being of residents. The study aims to deepen the understanding of this topic and explore the possibilities of technology integration in the Built Environment, precisely the adaptability of smart technology and AI possibilities in SHs. To accomplish this goal, a literature review and a case study will be conducted, with the primary research questions addressed in the case study.

1.6.2 Methodology

This thesis is divided into two main sections: the literature review, which delves into market analysis, and the case study. The literature review will explore the current state of SHDs and AI used in the Built Environment, focusing on the distinction between smart and intelligent devices, the safety of Smart Home Systems (SHSs), and the potential for AI to enhance the well-being of residents. In addition, the relationship between health and the indoor environment will be examined. The market analysis investigates various devices available in the market, reviews the literature about these devices, examines a Smart Home Device (SHD) company's perspective on AI, explores different simulation tools for house transformation, and underscores the significance of this process.

The case study will be centered around a 60-year-old citizen living in the suburbs in a semi-detached house with a history of health issues. Through a simulated transformation of his home into a smart house, this study will explore how smart and intelligent devices can be implemented to improve the resident's well-being using AI. Data on healthcare in the Netherlands will back up the defined parameters of the citizen's needs and will be used to set up guidelines for transforming houses into smart, safe house systems that promote well-being.

The case study will be conducted on three scales: the context of the surroundings, the analysis of the house, and data collection. The housing analysis will look into the spatial relationships of the rooms, the construction and detailing, and the indoor environment. The context of the surrounding scale will consider the house's location and its effect on the indoor environment. Finally, the data collection will look into the different datasets required to transform the house into a smart house. A climate analysis will be conducted using the Ladybug tools within the Grasshopper program to assess the environmental conditions of the house. This analysis will help evaluate the current conditions of the house and determine if any modifications are necessary to improve the indoor climate. The final step of the study will include creating a design, including façade drawings, floor planning, 3D modeling, and computational design, to demonstrate how a house can be transformed into a smart house that promotes the well-being of its residents using smart devices and AI.

After the transformation, a script is provided for integrating the Smart Home System (SHS) into real-life applications. This script is written in YAML code and implemented using Home Assistant. Concluding the case study, a prototype of a kinetic shading system is presented, created using a Raspberry Pi system and Python coding. The study showcases the effects of a smart shading system responsive to sunlight through graphs, leading to a drawn conclusion from this exploration.

1.7 Data collection and tools

1.7.1 Data collection

In this research, data collection is a critical component. This research uses a mixed-method analysis, using qualitative and quantitative data. The primary emphasis is on gathering quantitative data by measuring various parameters associated with the indoor environment, such as thermal comfort, and evaluating the current state of the house before and after the transformation. Additionally, quantitative data is acquired for the prototype, capturing its temperature and illuminance information.

A qualitative approach will also be employed where an interview with a SHDs company gains insights into the SHDs market and the understanding of AI used in these devices. The case study contains qualitative data using the residential hypothetical needs as a guiding tool for transforming the house into a smart home.

1.7.2 Tools

Ladybug Tools will be used for environmental analysis, which includes a set of simulation tools for assessing various aspects of building performance. Butterfly will assist in analyzing wind and internal airflow, while Honeybee will evaluate the building's heating, cooling, and lighting needs. These tools will guide the design choices for home transformation and indoor climate optimization. Honeybee uses Radiance to perform daylight simulations and integrates with OpenStudio and EnergyPlus to create energy models, providing an in-depth assessment of the building's energy use and load calculations, which is essential for a thorough environmental analysis.

The research will also look into Home Assistant, an open-source home automation platform, to understand how custom scripts and codes are developed for SHSs. The code will be written in YAML. This examination will help create a SH design tailored to the resident's individual needs, aiming to improve their well-being through enhanced living conditions. A Raspberry Pi will be used to prototype SH integrations, particularly for the shading system. This hardware will be the foundation for testing and implementing SH functions. Python will be the tool for writing the code to bring the smart shading system to life, allowing for automated adjustments based on environmental conditions and user preferences. These tools are crucial to the research, providing the means to transform homes into SHs that promote the well-being and comfort of those living in them.



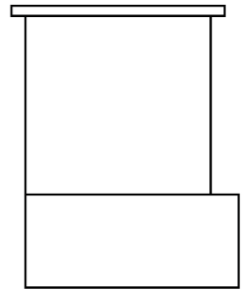

II LITERATURE REVIEW

2.1 Introduction to the State of the art

2.1.1 Digitalization, Internet of Things, and Smart Homes

Digitalization and the IoT have revolutionized home automation, leading to the development of SHs that are interconnected and intelligent. SH services have transitioned from basic automation to remote monitoring and control and now to context-aware intelligence. This evolution started with the rise of broadband internet, expanded with the widespread use of smartphones and apps, and has advanced to incorporate IoT and AI technologies (H. Yang et al., 2018). The idea of intelligent buildings took shape in 1980. During that era, these intelligent buildings primarily consisted of automation rather than truly intelligent systems (Kaboli & Shirowzhan, 2021). However, as computer technology progressed in the 2000s, remote monitoring and control became achievable through the Internet. Technology plays a pivotal role in our daily lives in our evolving world driven by digitalization. Figure 1 displays how building management has changed over the years. 1950 is the year that Building Control included air systems, automation, and fire alarms in buildings. By 1990, it had progressed to Building Automation with the addition of multifunctional systems. During the 2000s, these systems upgraded to enable computer compatibility, known as Building Performance. In 2010, the development of smart buildings consisted of a combination of modern IT technology for improving management and integration. The expectation for the future is the upcoming intelligent building, where the smart buildings have AI functions.

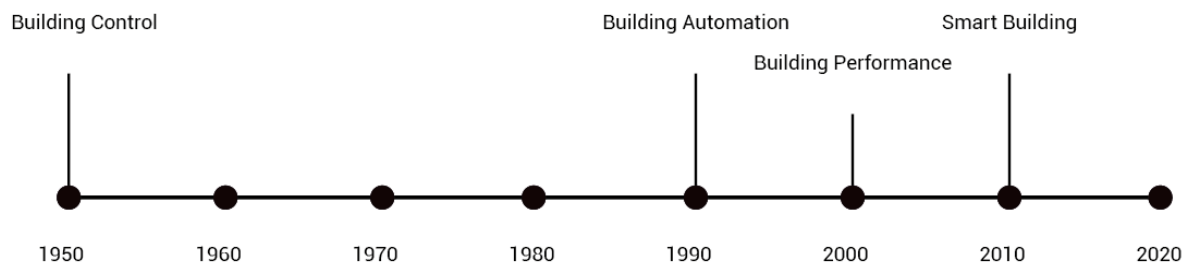

Figure 1: The evolution of smart buildings (Kaboli & Shirowzhan, 2021), created by author.

Nowadays, the most straightforward way to describe the concept of a SH, in general, is a home equipped with smart devices. The IoT is significant in smart house devices. It allows data to be created, transmitted, stored, and analyzed daily. Vrooman (2017) explains that SHs are combined IoT systems installed in a home environment. A system of interconnected computing devices connected to the Internet can send and receive substantial amounts of data without human interaction. This makes it possible to optimize the use of the house in a way that fits the residents needs. Arora & Pant (2019) explain that IoT is not about sensors and actuators but about two machines communicating with each other without human interference. Therefore, the IoT can generate valuable data on its own.

One of the aspects that relate to the SH industry is automation. Automation is achievable through monitoring energy consumption and managing the environment within buildings. Gunge and Yalagi (2016) explain that automation is an application of IoT technologies. They compiled an overview that compares different automation systems, communication interfaces, controllers, user interfaces, applications, and benefits. The benefits they mentioned are the effective management of semi-structured and unstructured data and the reduced computational burden of smart devices.

Structured data is highly organized and easy to search, like information in a spreadsheet with clear rows and columns. Unstructured data, like emails or social media posts, is messy and irregular, making it harder to organize and analyze. Efficient handling of structured and unstructured data is crucial in smart buildings, as it enables better control and optimization of building functions. By effectively managing both data types, smart buildings can use the information to automate and improve various building functions, enhancing overall efficiency and adaptability, which leads to more responsible and adaptive living spaces.

2.1.2 Upcoming Smart Homes Devices

The relationship between SHs and SHDs is foundational and integrative. SHs are living spaces with the infrastructure necessary to support SHDs, including houses, apartments, and offices. They provide the physical and network infrastructure that allows these devices to operate seamlessly and interactively within the environment. SHDs on the other hand, are the elements that bring intelligence to the SH ecosystem. They consist of various devices, such as smart thermostats, lighting systems, security cameras, voice assistants, and more, that can be controlled remotely and can often learn from user behavior to automate processes for efficiency and convenience.

SHT integrations offer multiple benefits, such as energy management, control of the domestic environment, and improved security. The advantages are in terms of cost, control, and convenience. However, multiple benefits have been addressed, such as saving energy, time, and money, improving security, enhancing leisure, and providing care and security, Wilson et al. (2017) address this and explain that the amount of energy SHTs consume after adaptation still needs to be determined.

While SHDs have many benefits, users consider certain critical points before using them. For example, in the Netherlands, nearly 75% of Dutch people over 12 used smart devices in 2020. 77% of those who do not have SHDs do not need them, 29% find them too expensive, and 25% have privacy or safety concerns (CBS, 2022). Over the last decades, the use of smart devices has increased. Many studies are done on SH; with the increase of the SHDs on the market, studies evaluated SHDs through research, but there is still much information out on the internet that needs a clear explanation of how smart these SHDs are for the users.

2.1.3 Difference between Smart and Intelligent

Understanding the distinction between "smart" and "intelligent" is crucial as it shapes user expectations and the development of technology that aligns with human needs. Clarifying this difference can also guide the design of user-friendly systems capable of making complex decisions without overstepping users' comfort levels regarding autonomy and control. The term "smart" generally implies intelligence akin to AI but varies in interpretation across different fields (H. Yang et al., 2018). There is a debate on how smart systems should substitute human decision-making, with many people hesitating to delegate control to machines fully. SH service adoption research has expanded from focusing on specific groups like the elderly or disabled to a broader user base. Factors like compatibility, safety, enjoyment, and cost influence the adoption of SHT.

Smart environments intuitively fulfill user expectations and create seamless, user-friendly interactions with technology. They prioritize user comfort and efficiency, often surprising users by how well they anticipate needs and preferences. Intelligent environments, on the other hand, are rooted in AI, focusing on problem-solving using formal logic and heuristics. They aim for satisfactory rather than optimal solutions, efficiently use resources, and can explain their actions so users can understand (Herczeg, 2010).

Having some measures for both definitions is beneficial to define the difference between intelligent and smart devices. In the article "What is a Smart Building?" Buckman et al. (2014) discussed the differences between Smart and Intelligent Buildings. According to the authors, smart buildings combine intelligence and building elements with a focus on adaptability, while intelligent buildings focus on reactive intelligence that utilizes information data. The distinction made by the authors indicates that intelligent buildings incorporate a more advanced level of AI than smart buildings.

According to Herczeg (2010), smart systems operate on defined rules that structure their code, whereas intelligent systems understand and interpret the meaning of data. Smart technology offers straightforward, intuitive interactions, while intelligent systems assist in problem-solving and decision-making. These differences are particularly relevant in AI, where intelligent systems mimic human problem-solving using methods representing knowledge and drawing conclusions. They apply formal logic and probability theory, considering rational methods and social and cultural contexts.

Intelligent systems proactively learn from users' behavior patterns, preferences, and decision-making processes, enabling intuitive user interactions. These systems are adept at grasping human context and intent, enabling users to use them effectively without requiring an understanding of how they operate. Through continuous learning from user interactions, these systems become more adept at providing personalized experiences (R. Yang & Newman, 2013).

Smart = adaptable (defined rules)

Intelligent = reactive (understanding and interpretation of data)

Intelligence can vary across different levels, and varying degrees of intelligence can define the ability to react as a cognitive mind. Some intelligent entities perform tasks, and some interact with their environment using AI. AI falls into four categories based on its virtual or physical presence and embodiment, ranging from robots to digital images. Chi et al. (2020) explain this and give the various levels of intelligence and devices them into four categories:

1. Mechanical Intelligence
2. Analytical Intelligence
3. Intuitive Intelligence
4. Empathetic Intelligence

Mechanical Intelligence refers to the use of robotics and automation in various applications. Analytical Intelligence involves using AI to analyze data, provide information, and answer inquiries. Intuitive Intelligence refers to AI applications that utilize intuitive capabilities such as room control through smartphones, making recommendations, etc. The last one is Empathetic Intelligence, which includes AI applications focusing on detecting and responding to human emotions.

This research will delve into SHDs by analyzing the levels of intelligence utilized in them. It will explore selected examples of SHDs that incorporate AI. It is important to note that intelligence in smart devices is a rapidly evolving field with ongoing research and development. As AI technology evolves and new applications emerge, developers are likely to create more straightforward methods for assessing the intelligence of smart devices. Chi et al. (2020) suggest further research to deepen the understanding of how AI affects diverse social groups and how users perceive AI technology. Considering this, a focus can be placed on the age group of 50-60 years in the Netherlands for this thesis to understand the possible different outcomes for the needs of this group in an SH.

2.1.4 The need for Smart Homes in the future

Integrating technology into homes transforms living spaces and addresses various health and societal challenges. This transformation is especially crucial given global demographic trends. Life expectancy has risen globally due to medical advances, better hygiene, and improved nutrition and education. However, this has led to a growing aging population and an increase in chronic diseases. With healthcare costs rising, there is a need for affordable healthcare solutions, especially for the elderly and those with disabilities. SHs equipped with sensors and remote health monitoring technologies offer a cost-effective way to provide continuous care and maintain independence for these populations, allowing for efficient tracking of health conditions and environmental factors from a distance (Majumder et al., 2017). In this scenario, smart homes enhance the living conditions for the elderly and people with disabilities, addressing the demand for cost-effective healthcare alternatives.

With the increasing population of adults over 65, addressing the critical aspects of using SHs is crucial. The challenges faced in an aging society include higher healthcare demands, the necessity for accessible home care, efficiency and quality within limited resources, and difficulties recruiting staff for home healthcare services (D'Ulizia et al., 2010). In the Netherlands, the age group between 50 and 60 has witnessed an increase in diseases compared to other age groups (CBS, 2023). Considering they will soon transition into the elderly stage (65+), focusing on this age group is crucial to ensure a healthy life and improve their quality of life. Introducing them to technology well in advance can be beneficial. Given this perspective, examining the SH market's technology use and relationship with the user's well-being becomes crucial. By making indoor places more comfortable and safer, aging in place will become more accessible for the aging society and the fragile groups with past health issues. SHs can significantly use technology and create an indoor environment that enhances users' well-being. According to Bugeja & Jacobsson (2023), the need for SHs in the future is primarily focused improving the quality of life through increased autonomy, personalization, connectedness, and sustainability. SHs are expected to manage daily tasks autonomously, offer personalized living experiences, maintain extensive connectivity with other devices and services, and promote sustainable living using renewable energy sources and efficient waste management. This evolution of SHs aims to improve comfort, security, and energy efficiency, which are central to smart living.

2.1.5 Architectural and Engineering Inputs for a Smart Home within Smart Cities

By 2050, the global population is projected to reach nearly 10 billion, with 70% residing in urban areas, which will demand a massive expansion of urban infrastructure. Smart Cities with high-tech connectivity are expected to become the norm, yet finding affordable and dignified housing that utilizes this connectivity will be challenging. Present construction methods are outdated, and there is an urgent need to embrace new prefabrication and digital fabrication techniques for building with precision comparable to medical devices. These advancements can support Population Health strategies, tackling rising healthcare costs, an aging demographic, urbanization, and a shortage of affordable housing. A concerted effort from professionals across various disciplines is essential to reinvent urban living and develop housing models that elevate the quality of life for all (Colstra, 2018).

According to Ghosh (2018) emphasizes the integral role of SHs in achieving the vision of smart cities. Such cities integrate advanced technologies, including information and communication technology (ICT) and the IoT, to enhance the quality of urban living. These innovations, from efficient energy systems to automated transport, address today's urban challenges and promote resource efficiency. From both architectural and engineering viewpoints, some considerations for SHs linked with smart cities encompass rainwater harvesting, solar panel integration, heat load evaluations with proper ventilation, and the establishment of Green Zones.

In this context, SHs are essential, and their design must be aligned with the broader smart city framework. Engineers are central to this effort, especially in shaping new and redeveloped urban spaces. Their expertise can lead to cost-effective solutions. Advanced tools, like Building Information Modeling (BIM) in Computer-Aided, support this process, enabling rapid and efficient assessments of building designs for sustainability and adaptability to future needs.

2.2 Smart Homes, well-being, and indoor comfort

2.2.1 Well-being, Health, and Indoor Comfort

Looking into the definition of 'well-being' gives an understanding of the relationship between well-being and health. Ross et al. (2020) explain the concept of well-being with a work frame of five different domains:

1. Good health and optimum nutrition
2. Connectedness, positive values, and contribution to society
3. Safety and supportive environment
4. Learning, competence, education skills, and employability
5. Agency and resilience

SHs can potentially encompass various domains, but this research primarily revolves around comprehending the concept of "health." Various researchers have conducted studies to

explore the relationship between health and the Built Environment. During this research, articles on the understanding of well-being have come across. In contrast, Dusseldorp et al. (2007) explain the standards for assessing the Indoor Environment Qualities (IEQ) in dwellings in the Netherlands. The National Institute for Public Health and the Environment document (Dutch: Rijksinstituut voor Volksgezondheid en Milieu or simply RIVM) factors that affect the indoor environment are the heating and ventilation system, which relates to the HVAC (Heating, Ventilation, and Air Conditioning) systems in buildings. The relationship of ventilation is measured by the Indoor Air Quality (IAQ), which is essential for human health. According to Pillie (2019), people spend approximately 90% of their time inside. This research relates the IAQ within and around buildings to the health and comfort of the residents and mentions that controlling indoor pollutants can reduce indoor health concerns. (EPA, 2022). One of the options to do this is by supporting natural ventilation.

Fortunately, with the help of advanced technologies, many SHDs that can be utilized to monitor environmental conditions are now available. Improving indoor climate and creating a healthier living environment can have significant impacts. Ventilation is one of the options to adjust IAQ because indoor pollutants are minimized in this way. Yang et al. (2021) explain that the indoor environmental quality of a residential home is a crucial issue that primarily depends on IAQ and thermal comfort. The combination of both will be considered in the case study during the hypothetical transformation of the house.

Indoor comfort is essential for a healthy house, related to the HVAC system and SHDs that will enhance the indoor climate and increase residents' well-being. Another point related to SHs is the safety and supportive environment; automotive and reactive SHDs could create this. This is not the scope of this research, but it is important to mention that this will play a significant role in a SH. In further chapters, the SHDs related to indoor climate and safety are evaluated to see what the market is offering for SHs.

Well-being ↔ Health ↔ Indoor Comfort

In the Netherlands, there are standards for assessing the IEQ in dwellings. Dusseldorp et al. (2007) listed this standard in The National Institute for Public Health and the Environment document (Dutch: Rijksinstituut voor Volksgezondheid en Milieu or simply RIVM); the factors that affect the indoor environment are:

- The age of the building, construction methods, and building materials used.
- The location of the dwelling, including groundwater levels and insolation.
- The heating and ventilation systems, including using flueless water heaters.
- Resident behavior includes smoking, keeping pets, and ventilation practices.
- External sources of pollution, such as traffic, aviation, industry, and soil contamination.
- Building finishes and consumer products used inside the dwelling.
- Natural substances found indoors.
- Maintenance and upkeep of the dwelling, including cleaning and repair practices.

Decisions made during a design process could significantly impact human health and the surrounding environment of the building. Designing the places correctly, where there is an improvement within the indoor environment, can reduce adverse effects caused by mental or physical diseases and motivate the residents to behave more positively, according to Mohtashami et al. (2016).

Heinzerling et al. (2013) explained that the buildings' IEQ performance affects the residents' health, productivity, and well-being. The IEQ of a building is defined through assessment class conditions, with the following conditions described in Table 1.

Assessment class	Indoor Air Quality	Lighting	Thermal Comfort
Healthy	CO < 8 ppm CO ₂ < 550 ppm	lx > 110	18.5 ≤ Air Temp. ≤ 24.5 °C 43 ≤ Relative Humidity ≤ 47% Airspeed < 0.45 m/s
Uncertain	CO < 10 ppm 550 ≤ CO ₂ ≤ 650 ppm	90 ≤ lx ≤ 110	17.5 ≤ Air Temp. ≤ 18.5 °C 37 ≤ Relative Humidity ≤ 43% 67 ≤ Relative Humidity ≤ 73% 0.45 ≤ Airspeed ≤ 0.55 m/s
Non-Healthy	CO > 10 ppm CO ₂ > 650 ppm	lx < 90	Air Temp. < 17.5 °C Air Temp. > 25.5 °C Relative Humidity < 37% Relative Humidity > 73% Airspeed > 0.55 m/s

Table 1: Summary of assessment class conditions for IEQ models adapted from Heinzerling et al. (2013)

Another important aspect of health within a house is lighting. Osibona et al. (2021) mentioned that natural light positively impacts health. Nevertheless, while it is advantageous for health to promote access to natural daylight, it is essential to ensure that this does not cause an unwanted rise in the building's temperature (Sam Kubba, 2010). Improving the quality of light in an indoor environment can improve energy efficiency by minimizing lighting, heating, and cooling loads, reducing the buildings' electricity consumption.

Another factor that influences indoor comfort is the urban heat island effect. Krüger (2015) explains that buildings can be affected by thermal comfort, ventilation patterns, and possible air quality. The study concludes that while UHI effects might be beneficial in winter, reducing indoor thermal discomfort due to cold, the same effect would increase heat stress in summer. There is a need for climate-responsive solutions to mitigate the adverse impact of urban heat effect and improve outdoor thermal comfort. Razzaghmanesh et al. (2016) have written about how green roofs can potentially mitigate urban heat effects, with variations observed based on the type of green roof and the materials used. Green roofs can contribute to sustainable urban development and address environmental challenges affecting indoor comfort.

2.2.2 Different Perspectives on Artificial Intelligence, Smart Homes, and Well-being

Several studies have been done on AI and SHs. For example, Sepasgozar et al. (2020) demonstrate the effectiveness of deep learning algorithms in detecting fraudulent mobile app behavior. Mobile apps' increasing prevalence and potential risks to users emphasize the importance of employing effective methods, such as deep learning algorithms, to detect fraudulent behavior and developing a deep learning-based framework that accurately analyzes mobile app behavior and detects suspicious behavior in mobile apps that deviates from normal behavior patterns. The deep learning-based framework developed by the authors can detect such anomalies and classify them as potential fraudulent behavior. The findings offer insights for mobile app security researchers, developers, and users concerned about device safety. Their study suggests that future studies can focus on alternative features or techniques to represent mobile app behavior, develop more efficient deep learning models, and reveal the potential of deep learning algorithms in enhancing mobile app security.

Another example of studies that have been done is the article where Rego et al. (2022) discuss developing an intelligent system for managing SH services to enhance users' quality of life. The system utilizes deep learning classification algorithms and reinforcement learning techniques to predict and prioritize services, enabling it to provide high-quality service with minimal user intervention. It also introduces the SH concept, which uses the IoT to enable users to access new services and automate home tasks. The intelligent system is designed to improve the quality of experience of SH services, focusing on multimedia services and minimizing user interruptions. The paper's authors designed the system's data preprocessing process, the classification algorithms, and the reinforcement learning system that enhanced its performance.

These two examples are practical because they give an understanding of the concept of AI and how it is used in SH fields. Research discusses deep learning and reinforcement learning methods and their applications in SHs. It also covers research on the well-being of SHs, and AI, especially for the elderly, which refers to people above 65 years. No specific research was found for the group category of 50-60 years other than the definition of health and which aspects this group might need to enhance their quality of life.

AI and healthcare are two fields that have witnessed extensive research. Qian et al. (2021) highlight the potential of AIoT, a combination of AI and IoT, to assist the elderly through various applications like health monitoring systems, fall detection mechanisms, SHTs, and remote care services. These innovations can enhance seniors' ability to live independently, minimize accidents and health issues, and improve healthcare provision. Assisted living and healthcare monitoring are crucial as more elderly individuals live alone than with caregivers. Assisted living focuses on analyzing the elderly' daily activities and providing proactive support, while health monitoring involves tracking health status and forecasting future health conditions. However, implementing these technologies in elderly care presents several challenges, including privacy concerns, compatibility issues, and user acceptance. The authors suggest that future research should address these challenges and develop more efficient and effective assisted living and IoT solutions for older adults.

The conclusion of this chapter highlights the abundance of studies conducted on AI in the contexts of smart houses and well-being separately. However, the combination of these elements—AI, smart houses, and well-being—has not been extensively explored. This intersection becomes a heavily researched field only when the indoor environment (indoor comfort) is considered.

2.2.3 Smart Home Devices and Indoor Comfort

SHs, as described by Vazquez & Kastner (2012), use advanced systems to enhance indoor comfort and energy efficiency. These systems, which adapt to individual habits and preferences, manage IAQ and thermal conditions. Their application utilizes occupancy, temperature, and humidity habit profiles to optimize IAQ and thermal comfort. Its operation varies with the home's occupancy status: In unoccupied homes, it actively controls shading devices, windows, and dampers to balance conditions and improve IAQ, aiming to maximize comfort and minimize energy use. In occupied homes, instead of direct control, it offers user advice to promote natural comfort efficiently. This approach integrates into broader SHSs, providing a holistic solution that anticipates needs and adjusts to personal comfort preferences.

Smart house design typically focuses on energy efficiency and convenience, with little attention paid to the occupants' health status. Chen et al. (2017) present a machine learning-based approach to improve building energy efficiency. The authors propose a method to predict energy consumption based on weather conditions and occupancy patterns. The system was tested in a university building, demonstrating high accuracy in predicting energy consumption and the potential for enhancing energy efficiency. The authors suggest extending this approach to other buildings and domains, such as SHs or industrial facilities. Additionally, the article proposes a mapping control strategy for HVAC systems in buildings that uses machine learning algorithms and building automation systems. The strategy optimizes energy consumption by mapping control strategies for each piece of equipment, adapting to changing weather conditions and occupancy patterns. The study found that the mapping control strategy, combined with machine learning algorithms, effectively optimized energy consumption and reduced operating costs in the university building. The study highlights the potential of using mapping control strategies for equipment combined with machine learning algorithms to improve building energy efficiency and the users' quality of life.

Until now, the research that is out there on well-being, AI, and SHs is based on the study of well-being, where lots of research is done on AI and well-being for especially elderly people, and on health and indoor environments, where HVAC systems are mentioned and how SHs can contribute to the health of the individual by enhancing the indoor environment and bettering the indoor comfort. The Market Review focuses on different AI used in SHs.

2.3 Smart and Intelligent Building Components

2.3.1 Smart and Intelligent Façades

According to Kraus & Drass (2020), the Building Information Modeling (BIM) approach regarding the life cycle of a building solves the digitization problem. It allows AI algorithms to be applied in different ways. A computable structural model is needed to apply AI for multi-criteria optimization and control. Such digital twin models contain an accurate 3D model that contains all features and functions of the physical system, including materials, sensor technology and dynamic of real structure. Figure 2 illustrates how health monitoring maintenance systems and intelligent façade systems can be integrated within a single façade project. It applies AI algorithms to ensure structures meet design standards and uses sensors to monitor building health, predicting maintenance needs. The system also learns user preferences to adjust the building environment for comfort. This approach aims to create smart, adaptive buildings that maintain themselves and cater to occupant comfort efficiently.

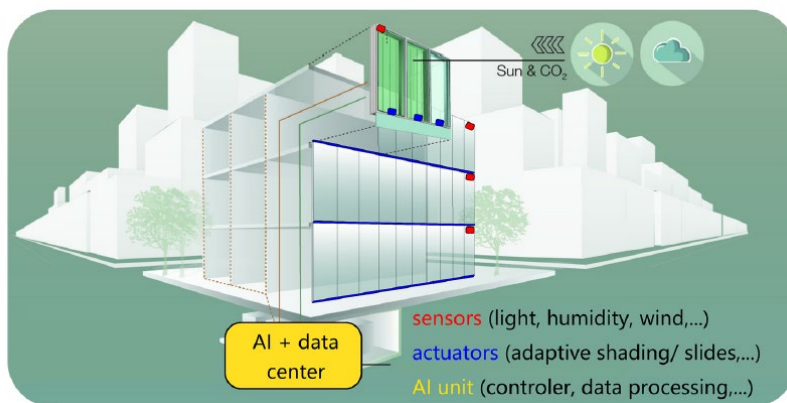

Figure 2: Schematic overview of an intelligent façade with health monitoring capabilities (Kraus & Drass, 2020)

The study indicates that although the principles of how external factors like light and heat impact user comfort are understood, these concepts have not yet been fully integrated or considered in current SHSs. While mechanical engineering has advanced in connecting devices (like the IoT), it has not effectively integrated civil engineering insights about human-building interactions. An AI that considers building physics can evaluate user data and adaptively learn a resident's preferences, offering a more evolved and personalized version of a "Smart Home" – an "Intelligent Home."

Smart façades are essential in modern architecture, acting as the building's interface and managing energy efficiency. They control energy flow, light, and heat while ensuring visibility and insulation from noise and weather. With the rise of technology, façades have evolved to meet functional and aesthetic needs, utilizing smart materials to optimize energy use, enhance durability, and enable the construction of lightweight yet resilient structures. According to Mofteq et al. (2018), there are three different smart façades: double skin façade, interactive façade, and kinetic façade. Double skin façades combine energy efficiency with an outer layer for insulation and an air cavity for thermal regulation. Interactive façades respond to stimuli with light displays or physical changes, while kinetic façades adjust to the environment to optimize energy and costs, enhancing the building's functionality and design.

According to Abbas (2023), smart façades are categorized into two types: those that adapt for energy conservation and those that generate energy. Interactive kinetic and smart glazed façades fall under the energy conservation category of adaptive façades. On the other hand, PV façades and small wind turbines are examples of energy-generating façades. While smart façades provide significant advantages like energy savings and better indoor comfort, smart façades also pose challenges in terms of complexity and cost. They require careful design and maintenance, considering climate and user needs. Despite these challenges, their potential for sustainability and efficiency makes them an increasingly popular choice in modern building design.

Kinetic façades are dynamic building exteriors that can change appearance or function in response to weather, user interaction, or energy efficiency goals. They add movement and adaptability to architectural design, creating visually engaging and responsive structures. These adaptive façades can improve the visual and thermal comfort of the building. However, these façades are usually not defined as smart façades, but as responsive and adaptable, they would fit into smart houses from an architectural and building technology perspective. Smart façades represent advanced building exteriors that integrate diverse technologies to enhance energy efficiency, adapt to environmental factors, and improve comfort for occupants. Within this category, kinetic façades stand out by altering their form or looking to meet changing conditions or requirements, employing dynamic movement and flexibility as key elements of their intelligent architecture.

In architectural design and building technology, two significant challenges that require attention are the comfort of occupants and energy consumption. Occupant comfort encompasses aspects such as thermal comfort and visual comfort, these are considered to be the two passive design parameters. (Figure 3) In a study by Hosseini et al. (2019), the authors elaborate on how kinetic façade concepts effectively address design issues and respond to varying occupant comfort requirements, thus making a valuable contribution to passive design strategies. This way, the occupant comfort is optimized using daylight control with a façade as the interface between the inside and outside environment as a proactive regulatory element against different climate conditions.

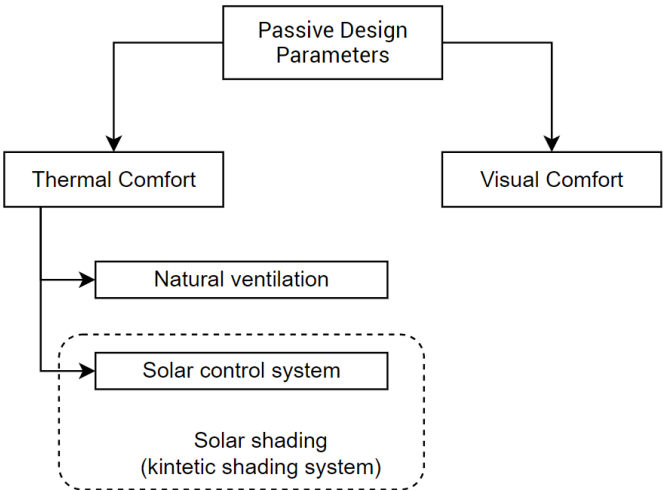

Figure 3: Passive design strategies for occupants' comfort and energy consumption adapted from Hosseini et al. (2019), made by author.

Kinetic façades can control the entry of natural light into a building, optimizing daylighting. This reduces the need for artificial lighting during the day, which aligns with passive design principles aimed at reducing energy consumption. By adjusting to external conditions, kinetic façades can help maintain thermal comfort inside the building. For example, they can block direct sunlight to prevent overheating or open to allow warm sunlight during the winter, thus reducing the need for heating or cooling systems. One of the building elements frequently used in creating kinetic façades is exterior movable shading devices. When controlled strategically, these devices are integrated into buildings and regulate the entry of solar radiation through the building's façade. As a result, they can have a notable influence on the building's energy consumption, particularly affecting the demand for heating, cooling, and lighting (Lee et al., 2016). While kinetic façades are typically active systems because they involve moving parts, they can be considered a part of passive design strategies. Passive design strategies take advantage of natural energy sources and environmental conditions to maintain a comfortable temperature range in the building. Kinetic façades (and kinetic shading systems) can be integrated into passive design principles to enhance energy efficiency, occupant comfort, and building sustainability. Well-designed kinetic façades and passive strategies can make buildings more responsive and eco-friendly.

2.4 Smart Home Transformations

2.4.1 Smart home transformation

The interaction between the resident and a SH affects the resident's well-being, the building performance of the house, and the environment. The technology embedded in a SH aims to enhance human use, comfort, and recreation, ensuring that the resident's needs are at the forefront of the design process. The transformation of an existing house to a smart house can be seen as a human-centered design process as it revolves around tailoring design principles to meet the specific needs of the residents.

Agee et al. (2021) highlight the significant impact of human-building interactions on well-being, building performance, and the environment, noting that people spend most of their time indoors. Despite this, current policies prioritize environmental and social sustainability over individual well-being, comfort, and satisfaction. The authors suggest that while the goal of creating high-performance housing aligns with these policies, it also introduces new challenges that require a human-centered approach.

The iterative design approach represents the ongoing process of design activities that include understanding user needs, creating design solutions, prototyping, testing, and refining the design based on feedback and user interaction. This process is repeated multiple times, allowing for continuous improvements and adjustments to meet better the physical, physiological, and psychological needs of the occupants. The iterative process is essential for integrating human factors into smart housing design, ensuring that the buildings are technologically advanced, user-friendly, comfortable, and conducive to the well-being of the occupants. Figure 4 emphasizes the ongoing evaluation and adaptation to align the design with human needs effectively.

The human-centered design is for the resident's physical, physiological, and psychological needs in a SH. Agee et al. (2021) combined data collection with human-centered methods, resulting in a human-centered approach to smart housing. The research unfolded in three methodological phases:

1. Energy analysis: Understanding the energy consumption patterns and identifying opportunities for efficiency.
2. Behavioral analysis: Examining the residents' interactions with the SHT and daily routines.
3. Persona development: Creating data-driven personas to encapsulate the diverse needs and preferences of different user groups, focusing on distinguishing between seniors and non-seniors.

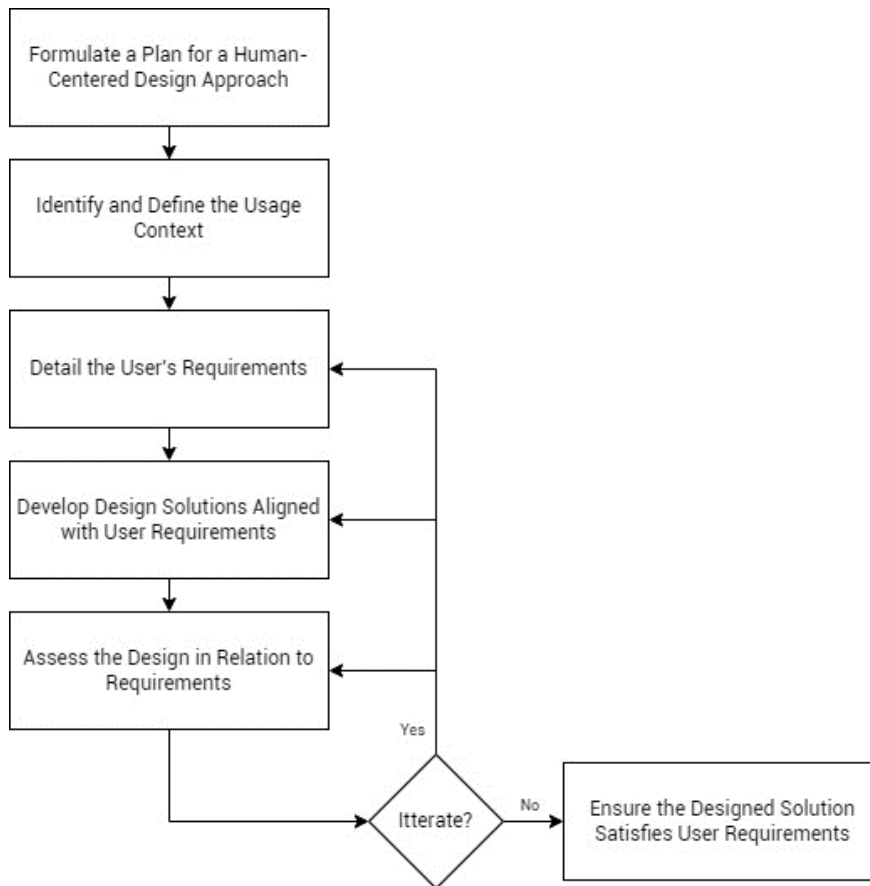

Figure 4: Iterative design approach adapted Agee et al. (2021) modified by author.

According to (Norman, 2013), the human-centered design process is crucial to ensuring that the final design aligns seamlessly with the needs and capabilities of the end-users. A well-executed design necessitates a deep understanding of the roles humans and machines play within the SH ecosystem. Agee et al. (2021) emphasize that as buildings become smarter, the architecture, engineering, and construction industry must adapt and adopt an iterative, human-centered approach. This approach is vital for maximizing human well-being and the operational performance of smart buildings, ensuring that the technology serves the residents and enhances their quality of life.

Kim et al. (2020) created a framework addressing three critical aspects of SHs: space, technology, and users. This framework focuses on the multimodal interactions between users and SHs. The purpose of this framework was to help designers, architects, engineers, and researchers explore and develop SHs in a more expanded and integrated perspective. The adapted version of the framework is, shown in Figure 5, illustrates the SH as a composite of space, technology, and users, all of which engage with an interactive environment. This environment is continuously connected and responsive, supported by intelligent computing and architectural design.

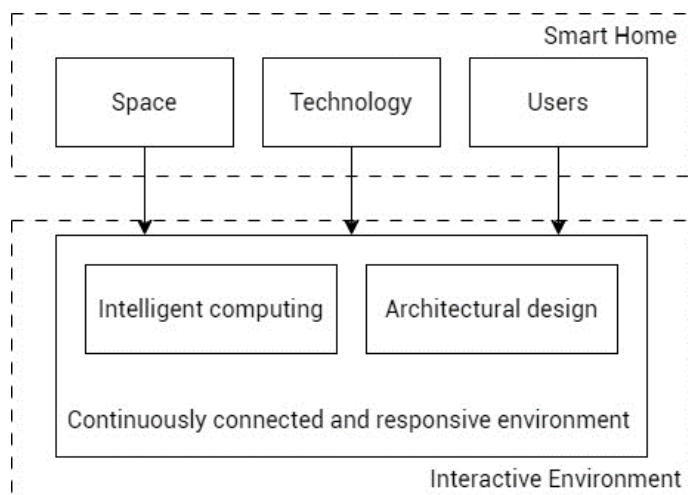

Figure 5: Relationship Smart Home and Interactive Environment adapted from Kim et al. (2020), modified by author.

Instead of solely focusing on technical aspects, this framework highlights the interconnected relationships between SHs and their users, emphasizing the multifaceted interactions that blend space and technology. The "space" aspect emphasizes user experience, while "technology" looks at how users perceive and accept innovations. The goal is to merge intelligent computing and architectural design, resulting in continuously connected, responsive environments that offer essential residential services tailored to inhabitants.

Transforming traditional homes into smart living spaces is a crucial change toward a more integrated and responsive way of living. This change is about creating a harmonious relationship between the residents and their living environments beyond adding new technologies. The process is deeply rooted in a design philosophy that puts humans at the center, ensuring that every new technology fits well with the resident's physical, psychological, and physiological needs. Through a comprehensive approach that includes looking at how energy is used, understanding the behavior of the residents, and helping them develop personally, SHs evolve to become extensions of the inhabitants' lifestyles and preferences. The innovative framework highlights the complex relationship between space, technology, and the people living in the home. This approach helps integrate smart technology and architectural design, creating living spaces that are always connected and adaptable and providing essential services for the people living there.

2.4.2 Smart Home Modification Process

Ma et al. (2022) discuss innovative technologies for SHs supporting independent living for older adults. They highlight the importance of user-centered design approaches in selecting and deploying supportive technologies within homes. While universal design is crucial for eliminating environmental and technical barriers in SH environments, it may not fully address individuals' diverse needs and housing variations. To help older people live comfortably and independently in their homes, there is a need for flexible living spaces and personalized changes that meet their unique needs and optimize the effectiveness of smart technology. The review concludes by emphasizing the need for further interdisciplinary research and real-life project verification to improve the approaches to designing and renovating SHs. Figure 6

shows the modification process, which is divided into four phases. The first phase is home assessment, which involves evaluating the current state of the home to determine what changes are necessary to make the building more suitable for the resident. The second phase is the technology selection, based on this assessment, appropriate technologies are chosen to be integrated into the home to address the identified needs. The third phase is the design strategy, a plan will be created for implementing the selected technologies will be implemented within the home environment. The last phase is the user evaluation, after modifications are made, the user evaluate the changes to ensure they meet their needs and preferences.

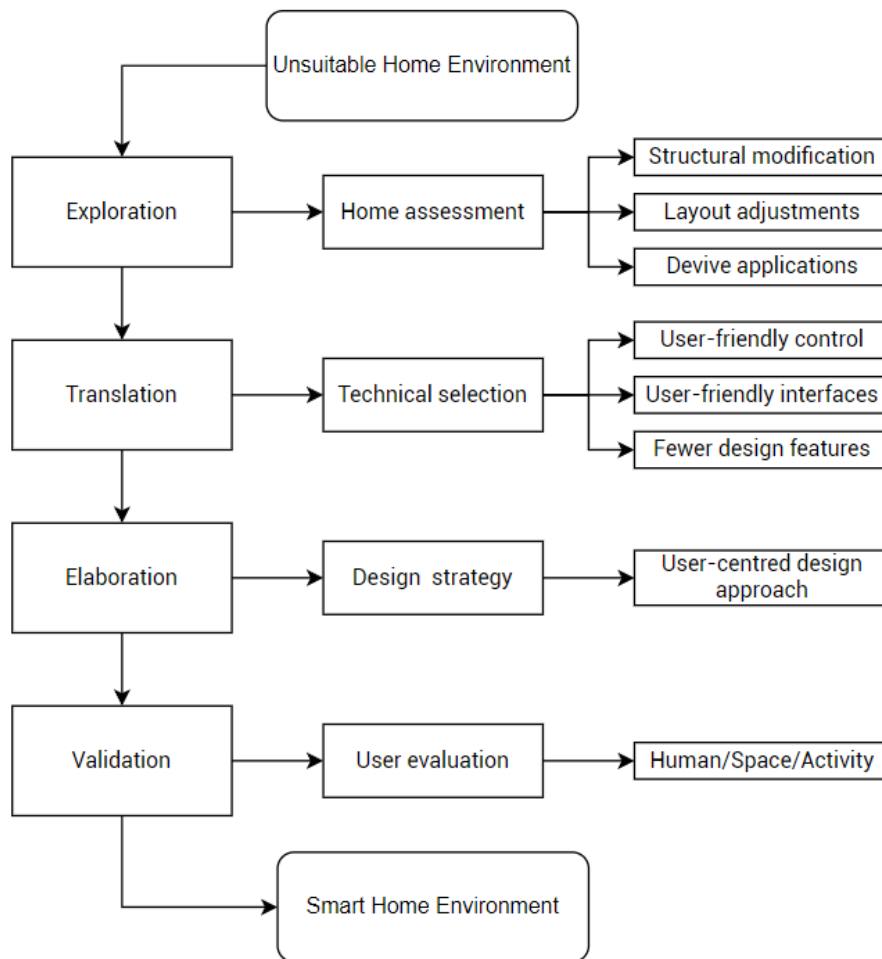

Figure 6: Smart home modification process adapted from Ma et al. (2022), modified by author.

SH modifications aim to support aging in place by incorporating new technologies into the home environment, making it smarter and more responsive to the needs of the elderly. The need for these modifications usually arises when older individuals find their current homes inadequate for their needs. The process encompasses four main phases: Home assessment, technology selection, design strategy, and user evaluation. This approach aligns with frameworks suggested by earlier studies, emphasizing understanding user needs, identifying necessary technologies, developing design concepts, testing in real-world settings, and finalizing solutions. Participatory design methods are a key feature of these processes. Since aging is a continuous process, homes may need multiple modifications. It is essential to adopt a holistic view to understand the potential benefits and challenges of integrating smart technologies for aging-in-place solutions.

Their research highlighted that studies on aging in place and SHs typically lean towards medical or computer science, emphasize wearable technologies, and employ medical research methods that may not fully capture the unique needs and experiences of the elderly or vulnerable groups. These methods often need more designs, processes, guidelines, or strategies tailored explicitly for these populations. Understanding these shortcomings can lead to more tailored and effective SH designs for the elderly, better guidelines and strategies for implementation, enhanced care and quality of life for aging populations, and a more interdisciplinary approach that bridges the gap between medical science, computer science, and user needs.

In summary, the transition to SHs tailored for older adults requires a user-centric design approach, ensuring technology integration aligns with their unique needs for independent living. The process involves thorough home assessment, careful technology selection, and strategic design, with continuous user evaluation to adapt to changing needs over time. While this integration presents challenges, including the need for interdisciplinary research and real-world testing, it offers a potential of creating adaptable, supportive living environments that enhance the quality of life and independence of aging populations.

2.4.3 Transforming Smart Homes into private diagnostic spaces

Monitoring residential health is a valuable part of a SH, especially for people with past health issues who need to track their well-being. Deserno (2020) mentioned transforming private environments such as SHs into diagnostic spaces by the following steps:

1. Use of existing sensors
2. Integrating additional sensors for vital sign monitoring
3. Transforming data storage into warehouses
4. Adding semantic interoperability and analytics
5. Opening communication channels

Firstly, existing sensors within SHs, including those for security and temperature control, can be adapted to gather health-related data. Secondly, integrating specialized sensors dedicated to monitoring vital signs, such as heart rate monitors, blood pressure sensors, or wearable health technology, can expand the scope of health data collection within the SHs. Ensuring the secure and efficient management of this data is another critical aspect. Transforming data storage into well-organized warehouses capable of effectively safeguarding health-related information is essential. Furthermore, improving meaningful data exchange and adding analytics tools enables SHs to understand and handle health data effectively, offering essential insights and possibly identifying health issues. Creating efficient communication channels in the SH ecosystem is crucial. It allows for the smooth transfer of health data to healthcare providers or family members when needed, aiding in prompt interventions and support for the well-being of residents. By methodically applying these approaches, SHs can become intelligent, health-aware settings, ultimately improving their occupants' quality of life and healthcare.

The vital signs monitored are the following:

- **Body Temperature:** A camera combined with machine learning algorithms can monitor body temperature. The camera can capture thermal images of the body, and machine learning algorithms can analyze these images to determine the body's temperature. This approach is non-invasive and can provide continuous temperature monitoring.
- **Heart Rate:** Various sensing devices can monitor heart rate. Accelerometers can measure physical movements associated with the heartbeat. Electrocardiography (ECG) or continuous ECG (cECG) sensors can directly record the heart's electrical activity graph (PPG). Sensors can optically detect changes in blood volume in the microvascular tissue to infer heart rate.
- **Respiratory Rate:** Accelerometers can monitor respiratory rate by detecting chest movements or abdominal contractions during breathing. ECG sensors can also help determine respiratory rate by analyzing the heart's electrical activity and breathing patterns. Additionally, cameras can track chest or abdominal movements, providing another non-invasive approach.
- **Blood Pressure:** Monitoring blood pressure typically requires a cuff-based approach. However, cameras combined with machine learning can indirectly estimate blood pressure by analyzing facial or ocular blood flow changes, although this method is still evolving.
- **Oxygen Saturation:** Often measured using a PPG sensor on the fingertip or earlobe, can determine the blood oxygen percentage. Cameras can also capture subtle color changes in the skin to estimate oxygen saturation non-invasively.
- **End-Tidal CO₂:** Monitoring end-tidal CO₂ levels can be done using cameras and machine learning. Cameras can capture images or videos of the face or respiratory movements, and machine learning algorithms can analyze these visual cues to estimate end-tidal CO₂ levels, which reflect carbon dioxide levels in exhaled breath.

SHs, with sensing devices and machine learning, offer continuous health monitoring. Wearable technologies provide real-time data, while bus-based systems ensure seamless operation. A symbiotic relationship between the resident and the house promotes well-being and independence, particularly for the elderly. These combinations of sensing devices and technologies offer non-invasive and often continuous methods for monitoring vital signs, making them valuable tools for healthcare and wellness applications. Machine learning enhances the accuracy and reliability of these measurements by processing the data obtained from the sensors.

The relationship between the house and the resident in monitoring residential health is symbiotic and mutually beneficial. The house is a platform for integrating various technologies and devices to enhance its occupants' well-being and health. This integration involves repurposing existing sensors and incorporating specialized sensors for monitoring vital signs, transforming data storage, enhancing interoperability, and establishing communication channels. The house, equipped with sensors for security, temperature control, and lighting sensors, uses these technologies to gather health-related data. It becomes an active monitor by continuously collecting information vital for assessing their well-being.

On the other hand, the resident is also an active participant in this relationship. They contribute by wearing or using health monitoring devices such as PPG sensors for heart rate monitoring and ECG sensors for recording electrical signals related to heart conditions. These wearable technologies enable the house to collect real-time health data, providing insights into the resident's physiological state. The result is a holistic approach to health monitoring within the home environment. The house becomes an intelligent, health-conscious space that leverages technology to promote the well-being of its residents. This synergy between technology and the resident is particularly valuable for individuals with past health issues or the elderly, as it facilitates aging in place by offering continuous health monitoring and support. Thus, the house and the resident form a partnership where technology enhances the individual's quality of life, health, and safety, fostering a sense of security and independence within the comfort of one's home.

By creating a bus-based system (Figure 7) for SHs, a communication network mirrors the system bus in a computer. This network links hardware components such as the CPU (central processing unit), memory, and peripheral devices. Transferring data and instructions among these components is crucial, enabling collaborative task execution and program operation. The bus-based system is integral to the SH's functionality, ensuring that all devices—from sensors to assistive technologies—are synchronized and operate cohesively to accommodate the needs of the elderly, thereby enhancing their ability to age comfortably and safely.

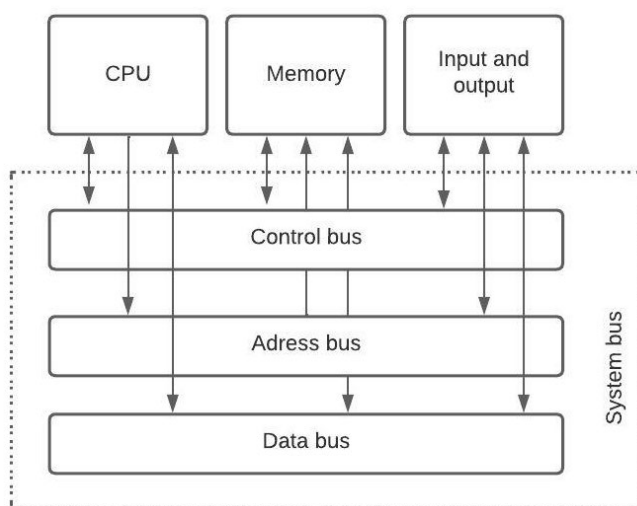

Figure 7: System bus explained, made by author.

SHs represent the peak of home automation technology, offering a fully automated experience by monitoring and adjusting environmental factors like temperature and security. A central unit processes real-time data from sensors to improve comfort, efficiency, and safety. The Building Automation by a Scalable Intelligent System (BASIS) system, highlighted by Deserno (2020), is a crucial advancement, organizing these sensors and devices via a network for efficient communication. In the BASIS framework, as shown in Figure 8, devices are grouped and controlled by segment controllers, which a central building manager then coordinates. This manager ensures all systems, including lighting and HVAC, work together smoothly based on algorithms and user settings and can be controlled remotely, allowing for updates and troubleshooting. SHs, through this complex network of technology managed by a central system, adapt to user needs, ensuring a living space that's comfortable, secure, energy-efficient, and responsive to changing lifestyles.

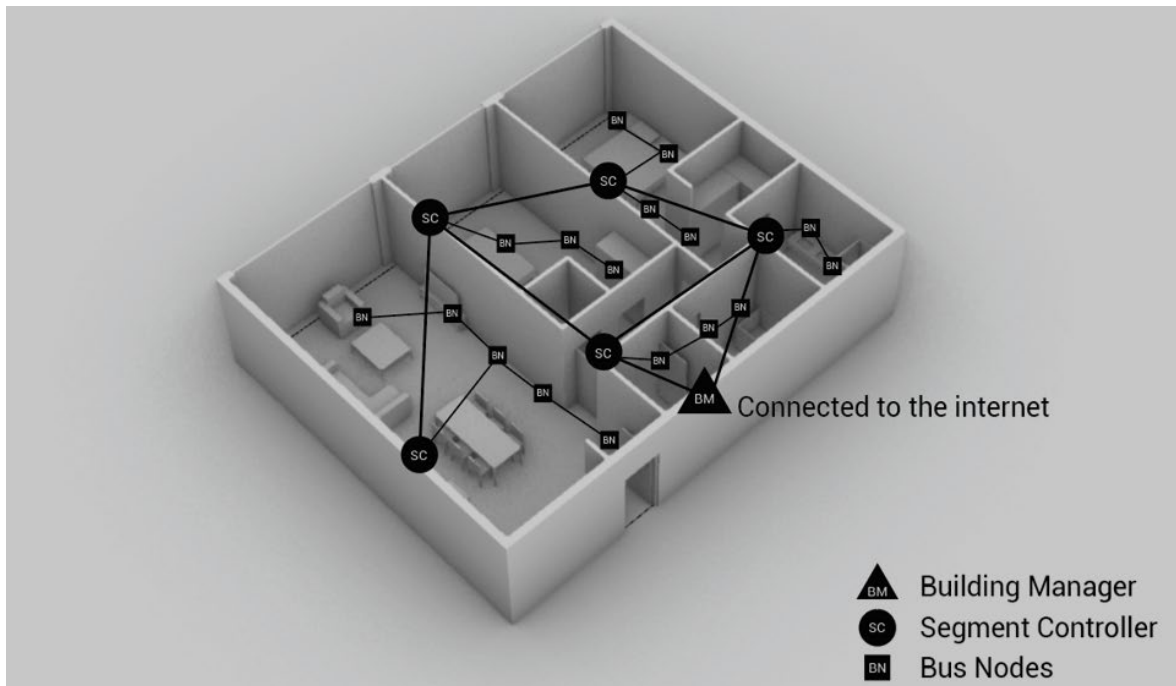

Figure 8: Building Automation by a Scalable Intelligent System (BASIS) for home automation Deserno (2020), modified by author.

In conclusion, transforming SHs into private diagnostic spaces significantly enriches the Built Environment, creating a living space that actively contributes to the health and well-being of its residents. By utilizing a combination of existing and additional sensors, these homes facilitate continuous health monitoring, which is especially crucial for those with previous health issues or the elderly. Integrating data warehouses and analytics transforms this data into actionable insights, enabling informed healthcare decisions and timely interventions. This proactive approach to health management within the home not only enhances the quality of care but also fosters independence and provides a secure, supportive living environment. This innovation signifies a transformative shift towards more responsive, health-centric living spaces for the broader Built Environment. It sets a new standard for residential design, encouraging the integration of health-monitoring technologies in homes and potentially influencing urban planning and community health initiatives. Ultimately, this innovation represents a crucial step towards a future where our living spaces play a central role in maintaining and improving our health, contributing to healthier and more sustainable communities.

Integrating health-monitoring technologies into SHs may necessitate structural changes to accommodate these new systems. Walls and other building elements must be retrofitted or designed with built-in channels for wiring and connectivity, ensuring that sensors and devices are seamlessly integrated and have the necessary power and data connections. This could lead to thicker walls or specialized panels that house the technology, potentially altering the home's interior and exterior aesthetics. Selecting materials that ensure robust wireless connectivity and prevent signal obstruction is essential in construction. Overall, the home's design plays a crucial role in health monitoring by enhancing the performance of the diagnostic tools installed throughout the house. The modifications to the home's structure are usually minimal. Still, to incorporate these technologies effectively, planning carefully and paying attention to detail is essential, ensuring the home remains visually appealing and functions correctly.

2.5 Privacy and Security

2.5.1 Challenges and Issues of Implementing Smart Home Safety and Security System

Safety and security systems are crucial for monitoring indoor environments, issuing alerts, and taking appropriate actions against potential risks. Alarm systems, gas leakage detection systems, and security systems to ensure the safety and security of residents are crucial in a SHS. The work of these systems involves monitoring the environment using sensors and reacting to unexpected incidents by sending alert notifications and taking appropriate actions. According to (Nicklas et al. (2016), a more detailed consideration of the security aspects of a SHS is crucial, especially concerning users and experts.

Sarhan (2020) explained the challenges and issues of implementing SH safety and security systems. These challenges include vulnerability to physical attacks, potential device failures that could impact the entire system, the risk of power outages disrupting services, dependence on the Internet for notifications, and concerns about software compatibility.

Additionally, issues arise from using non-original devices, lack of standardized software compatibility, and security threats associated with IoT components. Overcoming these challenges requires strategic measures such as secure device installations, continuous device status monitoring, alternative power sources like solar panels with rechargeable batteries to power the system, periodic checks for Internet connectivity, and implementing advanced security measures.

2.5.2 Monitoring Security System

Suzuki et al. (2018) wrote about SH solutions for elderly family members living alone. They designed an IoT watch-over system device with motion and temperature-humidity combined sensors. Due to privacy concerns, the systems did not use cameras or microphones. These sensors were put in all the house rooms and were designed to stop monitoring the elderly resident whenever other family members arrived home.

The alerts were set on specific room use conditions, which must differ for everyone. Figure 9 shows how these requirements can be put into a graph to understand the different functions of each sensor in the rooms.

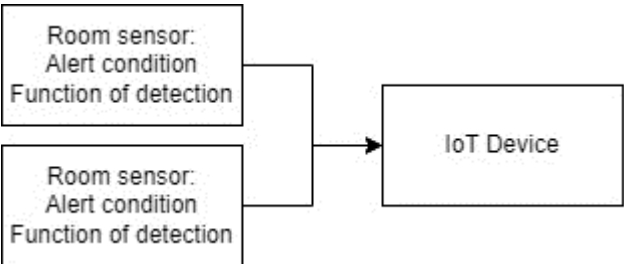

Figure 9: Sensor devices communication with IoT devices, created by author.

For example, the temperature and humidity conditions within a room will be communicated with the IoT device for modification when they are under the norm of a healthy environment, as shown in Figure 10. In cases involving the elderly, a motion sensor can observe the occupant's regular patterns and activity within the house. Suppose it detects prolonged inactivity in a specific area or unexpected movements. In that case, it can activate an alert system, prompting a family member or neighbor to check on the individual via their IoT device.

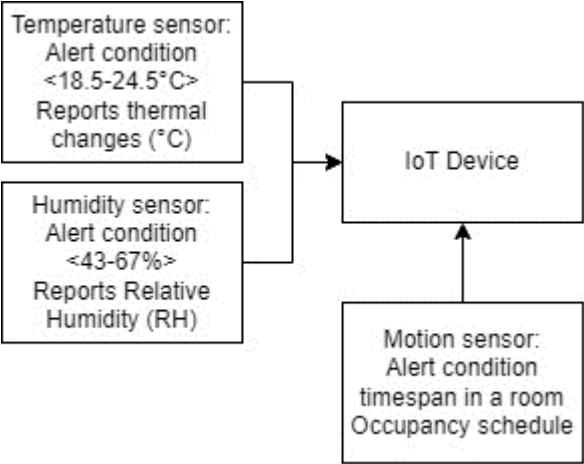

Figure 10: Sensor devices and conditions set to communication with IoT devices, created by author.

2.5.3 Privacy and Security Concerns

Lin & Bergmann (2016) highlighted the growing interest in SHTs. Interconnected devices and applications aim to make homes more efficient, convenient, and connected. The authors explored the different technologies and devices crucial in SH networks. SHs often involve many devices with resource and energy limitations. Ensuring the security of these devices can be challenging. Therefore, implementing robust security algorithms in SH networks is essential. Another critical security concern is end-to-end security in heterogeneous and unreliable wireless networks. SHs typically rely on wireless communication; securing data transmission and communication between devices is vital. Beyond digital security, the authors also address the issue of physical security in SHs. This includes safeguarding the SH ecosystem from unauthorized access to devices and ensuring the physical security of smart devices, vital in preventing physical intrusions. Figure 11 displays the security solutions for IoT devices in SHs.

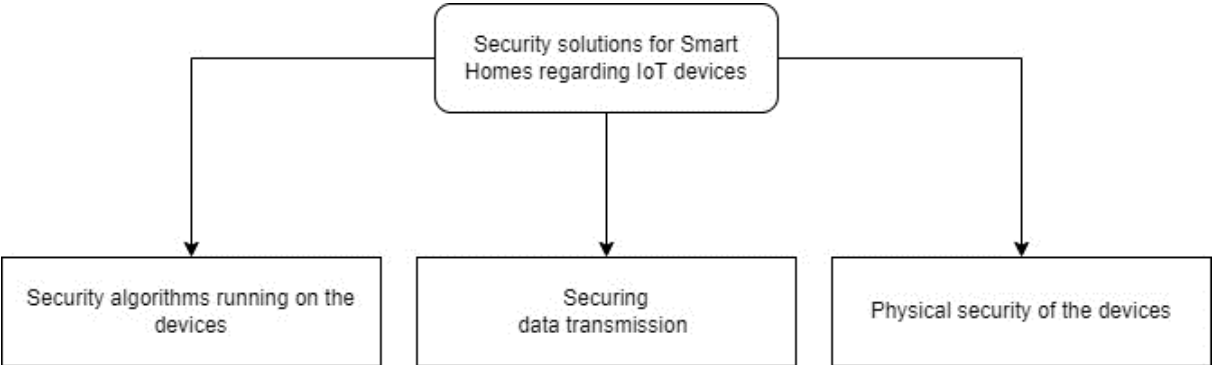

Figure 11: Security solutions Smart Homes for IoT devices, created by author.

Regarding privacy threats, Zainuddin et al. (2021) explained these include data leakage, eavesdropping, and impersonation. SHDs include hardware like sensors, actuators, gateways, and smart objects, and they allow users to remotely control various home functionalities, such as lighting, air conditioning, and appliances, via different platforms like PCs and smartphones. These devices have the potential to hold sensitive data, including personal photos, videos, and records, and some can be remotely activated and accessed. However, these devices bring along privacy concerns. Research has pointed out that residents are exposed to privacy risks as their data can be accessed remotely in novel ways. Even with data protection, an observer can infer important information by observing the network activity of SHDs. Additionally, attackers can utilize wireless techniques to access unsecured data from these devices.

V. Z. Lin & Parkin (2020) surveyed 97 smart assistant owners, most shared their devices and relied on social trust over formal privacy controls. Many needed to be made aware of or rarely used specific privacy features. The study found a limited transfer of privacy habits from other devices to smart assistants, suggesting that predicting such behaviors is challenging. Future research will focus on understanding the transferability of privacy practices across devices. Integrating safety and security measures in SHDs requires a comprehensive approach considering technological challenges and privacy implications for users. Balancing security with privacy-conscious design and user awareness is crucial for successfully implementing SH solutions.

2.6 Market Analysis

2.6.1 Smart Homes Reference Projects

Phong House is an example of a house renovated into a SH that improves the quality of life. (Figure 12) Technologies are applied to control lighting, climate, entertainment systems, and appliances. (Smart Homes That Use Demotics' To Improve Quality of Life | ArchDaily, n.d.) The house is located in Hòa Xuân, Vietnam. Completed in 2018, the house was refurbished by the architects Vo Huu Linh, Vo Huu Hieu, Nguyen Tran Hong Hen, Nguyen Anh Tuan, VHL. Architecture Co. Ltd. Figure 1 shows the house before and after the transformation (Phong House/ VHL.Architecture | ArchDaily, n.d.).

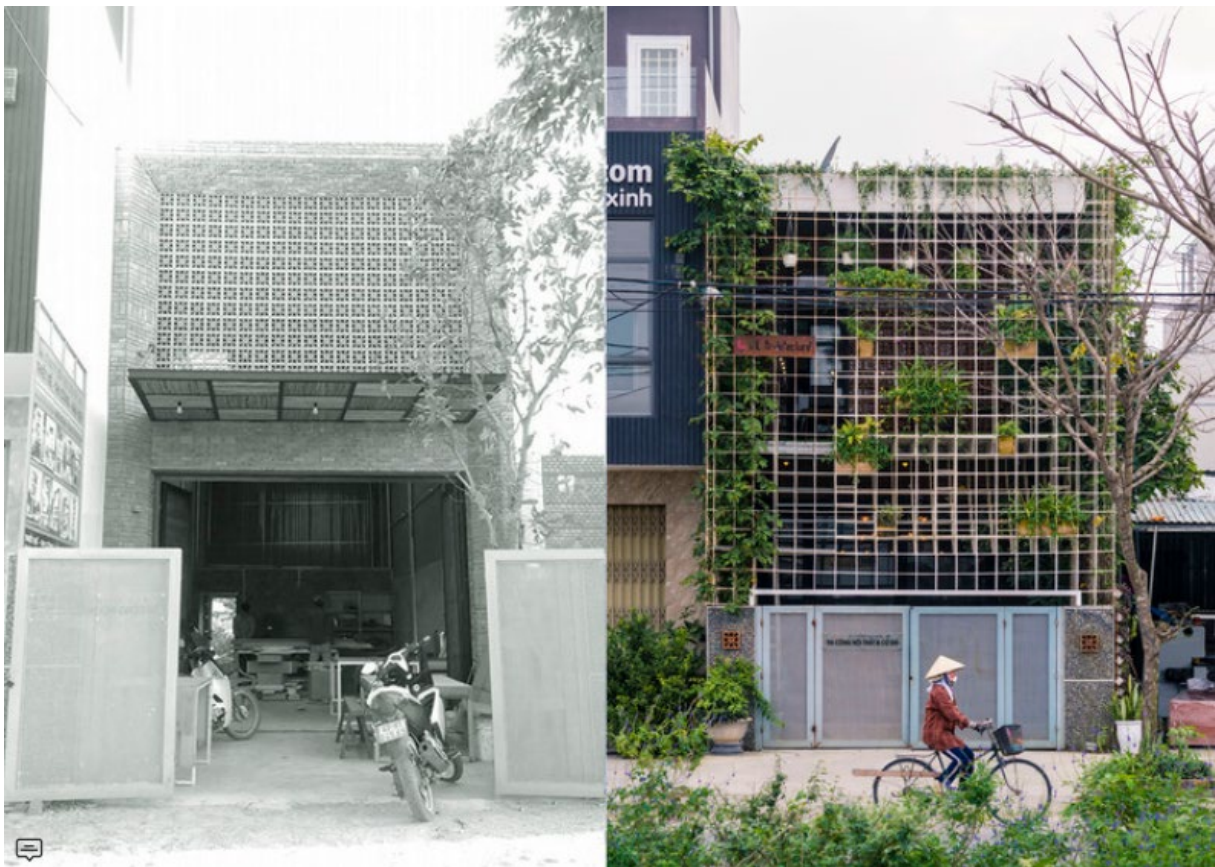

Figure 12: Phong House, photograph by Kingkien (ArchDaily, n.d.)

This reference project is a good fit for this thesis because it focuses on the resident's quality of life, meaning the standard of health, comfort, and happiness experienced by an individual. By analyzing the house, the conclusion is that the transformation emphasized open spaces and incorporated greenery. This implementation is made in the spatial relationship of the house and the façade; these implementations made it possible to create a better comfort of the house. This project is based on the working class, looks at the relationship between health and residency, and is a smart house.

The house was a factory in the past that was transformed into a house, and the targeted group is young couples. It is based on the principles of working from home, which, after COVID-19, has become very popular in the Netherlands and which principles can be used for transformation. The factory is renovated into masonry, using prefabricated construction elements for low costs. According to ArchDaily (n.d.), the house's philosophy is the value of local spaces. The principle of this transformation is the focus on residents and nature; by applying a double façade, more outdoor spaces, and greenery, the indoor climate is optimized within the building. This helps minimize the use of HVAC system equipment because if the design supports natural ventilation and protection from the sun, this reduces energy costs, and natural heat, ventilation, and air systems are preferable overusing the equipment.

Another example of a smart house is the 'Slimste huis van Nederland' in Eindhoven, designed in 2016 for elderly people. (Figure 13) This house is designed in three stages:

Stage 1: Infrastructure

Stage 2: Applications and devices

Stage 3: Control panels



Figure 13: Slimste woning van Nederland (Slimste Woning van Nederland, n.d.)

Automated lights, videophone front door, control panels, robot recognizing the mood of the resident, a wristwatch with sound alarm when the resident falls, digital coach giving health advice, urination route for the night with warning signals when the resident is not returning, a security system that is checking if the resident is home, cameras with speaking and listening functions and a doorbell with lights that can be turned off are all the things that this SH contains (*"Welkom in de Slimste Woning van Nederland,"* n.d.). "Het slimste huis van Nederland" is a SH design tailored for older adults, while the Phong House is designed for the working class. Both of these designs emphasize smart features inside the home. On the exterior, there is no indication that these are technologically advanced homes. When researching or referencing projects related to SHs, it appears that the presence and integration of smart devices inside the house primarily define what is considered a "Smart Home." Another observation was that many SHs featured open spaces within their design. One potential reason could be to reduce the number of SHDs needed. Incorporating more open spaces into SH designs can bring various benefits and implications, providing aesthetic and well-being advantages and posing considerations for integrating smart technologies. Open spaces in the context of SHs typically influence living spaces' architectural, functional, and experiential aspects.

2.6.2 Classification of Smart Home Technology

Liao et al. (2023) analyzed 1034 papers on SHs for the elderly. They mentioned the need for SHs because of the aging society every country will face. The combination of the subject areas of computer science, engineering, and telecommunications was used for their research. They wrote a SHT classification using the different scenarios made for the seniors. The SHTs were classified into four categories: the daily living environment and quality of life, energy management and sustainability, healthcare, and life security, and social and entertainment. This classification of the SHTs is shown in Table 2.





Smart Home Technology Classification			
Daily Living Environment and Quality of Life	Residential Security	Activity Monitoring (CCTV)	
		Threat and Intrusion Monitoring	Door Window
		Carbon Monoxide Alarm (co)	
		Water Flooding Alarms	
		Intelligent Electronic Door Lock	
	Environmental Renovation	GPS	
		Smart Workspace Renovation	
		Smart Bedroom	
		Kitchen	
		Restroom	
Energy Management, Sustainability and Indoor Comfort	Environment Detection (automation)	Indoor Air Quality	
		Light Control	
		Temperature Control	
		Humidity Control	
		Ventilation Control	
	Energy-saving control system	Electrical Control -on/off	
Healthcare and Life Security	Energy Monitoring	Visualization	
		Fall Detection	
	Wearable Devices	Abnormal Behavior Detection	
		Gait Analysis	
		Emotion Recognition	
		Behavior Change Detection	Sleep
			Eating
			Medicine
			Blood Sugar
	Heart Rate Temperature		
Non-wearable Devices	Fall Detection		
Telemedicine			
Social Contact and Entertainment	Integrating Face Recognition		
	Speech Control System		
	Gesture Control System		
	Socially Assistive Robot		
	Virtual Reality (VR) and Augmented Reality (AR) Device		

Table 2: Classification of Smart Home Technologies, made by Liao et al. (2023), modified by author.

The Built Environment links to energy management, sustainability, and indoor comfort. SHTs aim to address indoor conditions and monitor environmental factors influencing the indoor climate. The next step involves assessing the existing market for SHDs dedicated to environmental detection to gain insight into the data these devices can gather and the sensors they utilize for data collection. The analysis of SHTs is crucial as it provides a structured overview of how such technologies can enhance the lives of the elderly. By classifying these technologies like daily living support, energy management, healthcare, and social engagement, it becomes easier to identify and develop specific solutions to aid seniors in maintaining independence and improving their quality of life. This classification also underscores the need for an interdisciplinary approach to advancing these technologies, integrating insights from computer science, engineering, and telecommunications to serve the aging population better.

2.6.3 Smart Home devices on the market

Previous chapters have explained the definition of SHs and their relationship between SHDs. This chapter investigates the SHDs on the market and tries to understand what is out there, how smart these devices are, and what is missing. Different SHDs are on the market for the indoor comfort of the house. During the research, searching for various SHDs did not provide the desired clarity regarding these devices available in the market, as envisioned when starting this research. To broaden the perspective and obtain data on devices apt for indoor settings, GPT-3.5 receives questions about various SHDs relevant to indoor environments. This process involves categorizing these devices under ventilation, lighting, noise control, thermal comfort, and humidity, specific to indoor settings. However, the provided data could have been more reliable. There were several inaccuracies, especially when inquiring about devices equipped with AI. For example, when probing about SHDs that employed computer vision and camera technology, GPT-3.5 mistakenly listed SHDs that lacked cameras under the humidity device category. In cases of detected discrepancies, further queries to GPT-3.5, such as "Is that so?" or "Does this device have a camera in it?" usually led the model to recognize its errors and provided a corrected answer. Table 3 showcases examples of environmental detection devices used in SHs. This table is based on the categorization of the classification of SHT by Liao et al. (2023) for the category of environmental detection.

Environment Detection (automation)	Indoor Air Quality	Awair's Glow C air quality monitor ¹	Humidity temperature sensor	Controls humidity levels and avoids the risk of mold build-up	 (Awair Glow, n.d.)
	Indoor Air Quality	Netatmo Smart Indoor Air Quality Monitor ²	Temperature, humidity, noise levels	A smart home device that monitors air quality, temperature, and humidity.	 (NETATMO, n.d.)
	Indoor Air Quality	Airthings Wave Plus ³	Temperature, Humidity, and Air Pressure	Adjust ventilation and air purification settings based on the number of people present.	 (Wave Plus, n.d.)
	Indoor Air Quality Temperature control Humidity control	Eve Room ⁴	Air quality, Temperature, Humidity sensor	A smart home device that monitors temperature, humidity, and air quality sends alerts when environmental factors fall outside of a set range.	 (Eve Room, n.d.)
	Indoor Air Quality Humidity Control Temperature Control Light control	Velux Active with Netatmo ⁵	Temperature, humidity, and CO2 sensor	Smart sensors monitor the air quality levels in the house and open/close skylights and blinds to create a healthier indoor climate.	 (Netatmo, n.d.)

¹ Introducing awair glow c. (n.d.). <https://www.getawair.com/blog/introducing-awair-glow-c>

² NETATMO. (n.d.). Smart Indoor Air Quality Monitor | NetaTMO. Netatmo. <https://www.netatmo.com/en-eu/smart-indoor-air-quality-monitor>

³ Wave Plus. (n.d.). <https://www.airthings.com/en/>. <https://www.airthings.com/en/wave-plus>

⁴ Eve Room | evehome.com. (n.d.). evehome.com. <https://www.evehome.com/en/eve-room>

⁵ VELUX ACTIVE with NETATMO - Indoor climate control starter pack. (n.d.). Shop Netatmo. <https://shop.netatmo.com/nl-nl/aircare/velux-active/indoor-climate-control-starter-pack>







	Light Control	Philips Hue Motion Sensor ⁶	Daylight sensor	Detects the amount of natural light in a room and adjusts the brightness and color temperature.	 (Hue Hue motion, n.d.)
		Lutron Serena Smart Shades ⁷	Daylight sensor	Detects the amount of natural light in a room and adjusts the position of the blinds automatically for natural light optimization.	 (McBride, n.d.)
	Temperature control	Nest Learning Thermostat ⁸	Temperature sensor	Tracks temperature in different rooms at certain times of the day. Adjust the house's temperature based on the occupancy schedules.	 (Google Nest Thermostat, n.d.)
		Honeywell Lyric T6 Pro Wi-Fi Thermostat ⁹	Temperature sensor	Adjust the home's temperature to maintain a comfortable level.	 (Honeywell, n.d.)
	Temperature control Indoor Air Quality	Ecobee Smart Thermostat ¹⁰	Temperature sensor	Smart thermostat adjusts indoor temperature for indoor comfort and supports the HVAC system of the building. Works with IoT voice assistants.	 (Ecobee Smart, n.d.)
	Humidity control	Xiaomi Smartmi Air Humidifier ¹¹	Water level sensor	Prevents the room from having dry air and controls the humidity levels in the room for indoor comfort.	 (Xiaomi Smartmi, n.d.)
	Humidity control	Honeywell Home Dehumidifier ¹²	Humidity sensor	A smart dehumidifier that can monitor and control the humidity levels in your home, controllable through a smartphone app or voice commands.	 (Honeywell Home, n.d.)

Table 3: Classification of Smart Home Technologies with Smart Home Devices , made by author.

There are three SH ecosystems on the market: Alexa, Google Home, and Apple Home; these ecosystems group all technology devices under one umbrella. In terms of functionality, they are all similar. The criticism is that their systems need to talk together better when fitting under one umbrella. The automation of these devices is simple; for example, turning them on at a specific time is possible, but they need help to make complex automation.

⁶ Hue Hue Motion sensor | Philips Hue NL. (n.d.). Philips Hue NL. <https://www.philips-hue.com/nl-nl/p/hue-hue-motion-sensor/8719514342125>

⁷ McBride, L. (2023, September 11). Lutron's Serena Smart Shades - Lauren McBride. Lauren McBride. <https://laurenmcbrideblog.com/2021/06/lutron-serena-smart-shades/>

⁸ Nest Learning Thermostat. (n.d.). https://store.google.com/be/product/nest_learning_thermostat_3rd_gen?hl=nl

⁹ T6 Pro Smart Thermostat Multi-Stage 3 Heat/2 Cool | Honeywell Home. (n.d.). Honeywell Home. <https://www.honeywellhome.com/us/en/products/air/thermostats/wifi-thermostats/t6-pro-smart-thermostat-multi-stage-3-heat-2-cool-th6320wf2003-u/>

¹⁰ Smart Thermostats & Smart Home Devices | ecobee. (n.d.). <https://www.ecobee.com/en-us/>

¹¹ Xiaomi SmartMi Pure Evaporative Air Humidifier 2 - TechPunt. (n.d.). TechPunt. <https://www.techpunt.nl/nl/xiaomi-smartmi-pure-evaporative-air-humidifier-2.html>

¹² Dehumidifiers | Honeywell Home. (n.d.). Honeywell Home. <https://www.honeywellhome.com/us/en/products/air/dehumidifiers/>

This search for SHDs for indoor climate gave an idea of the SHDs on the market, but how smart these devices are needs to be clarified. Some of these devices predict the occupancy schedules for their uses based on the gathered data throughout the use of the device. However, this artificial application in the SHDs differs from the desired intelligence outcome expected for these devices. In conclusion, finding SHDs within a specific category can be difficult. Websites still need to provide knowledge about these devices that are easy to comprehend. This experiment on finding SHDs based on their function has been time-consuming and led to minimal outcomes. It could be valuable to have a website in the future with a chatbot where users can prompt their needs for specific SHDs and their technical specifics and levels or possible AI used within these devices. For example, this is valuable for engineers evaluating indoor comfort and aiming to optimize it within a building.

2.6.4 Literature on Smart Home Devices on the market

Guo et al. (2019) explained six different categorizations of AI within devices. (Figure 14)

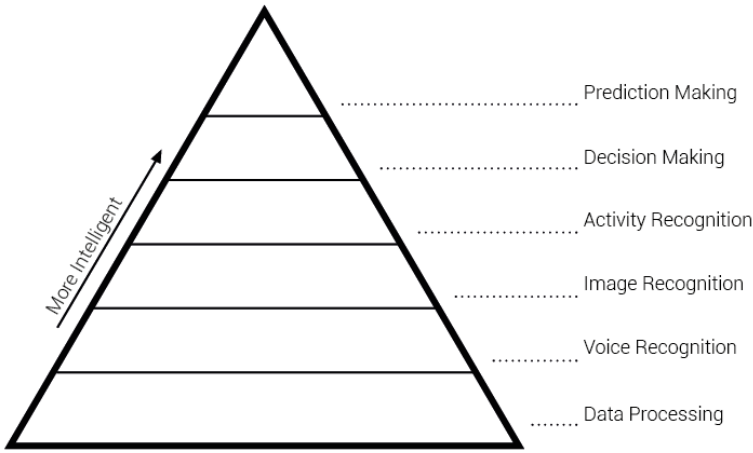

Figure 14: Artificial Intelligence within Smart Devices, made by author.

AI encompasses a range of functions that empower devices with specialized capabilities. Activity recognition enables devices to detect and understand human actions, such as walking or opening a door, often using sensors or cameras. Data processing involves sorting, analyzing, and interpreting vast amounts of information efficiently to extract meaningful insights. Voice recognition focuses on distinguishing and comprehending spoken words, enabling interactions like voice commands. Image recognition allows devices to identify and classify visual data, such as faces or objects in pictures. Decision-making allows AI to make choices based on analyzed data, optimizing outcomes. Lastly, prediction-making involves forecasting future events or trends based on existing patterns. Combined, these functions showcase AI's adaptability in understanding, analyzing, and responding to diverse inputs. Guo et al. (2019) explained AI applied in the following devices shown in Table 4.

Essence Care@Home ¹³	Social Alarm for seniors to live independently at home. Detects fires and leaks allows seniors to call for help anywhere in their homes.	Activity recognition	 (Essence SmartCare, 2023)
August smart lock + Connect ¹⁴	Automatically lock and unlock system. Connected with phone. Generate guest keys for shared access, code entry with smart keypad.	Data processing	 (August Home, 2020)
Nest Protect ¹⁵	A fire alarm detector connected to a mobile device gives alerts	Data processing	 (Nest Protect, n.d.)
Josh Micro ¹⁶	Voice control, for commands as turning lights on, sensors enabling more smart automation.	Voice recognition	 (Josh Micro, n.d.)
Amazon Alexa ¹⁷	Smart speaker with a clock can be used as an alarm clock for conversations and listening to music.	Voice recognition	 (Amazon Alexa, n.d.)
Athom Homey ¹⁸	Enables controlling devices from the phone, tablet, or desktop. Gives notification from motion sensors or information smart devices installed in the house.	Voice recognition	 (Homey, n.d.)
Jibo ¹⁹	A personal robot designed as a companion and helper to the resident.	Voice recognition	 (Jibo, n.d.)
Ivee Sleek ²⁰	Wi-Fi Voice-activated assistant for the smart home. Answers questions, obey commands, and controls other internet-connected devices.	Voice recognition	 (PCMag, 2014)
Google Home ²¹	Home pod assistant activates music radio and can activate other smart home devices like lightning.	Voice recognition	 (Google Hme, n.d.)

¹³ Essence SmartCare. (2023, June 20). Technology Enabled Care Advanced Emergency Response for seniors. <https://www.essencesmartcare.com/products/carehome-pers/>

¹⁴ August Smart Lock + Connect | Products | August Home. (2020, June 10). <https://august.com/products/august-smart-lock-connect>

¹⁵ Nest Protect smoke and CO alarm. (n.d.). https://store.google.com/nl/product/nest_protect_2nd_gen?hl=nl

¹⁶ Josh.Ai. (n.d.). Josh.ai | Josh micro. <https://www.josh.ai/micro/>









¹⁷ Amazon.nl: Amazon Echo: Amazon-apparaten & accessoires. (n.d.). <https://www.amazon.nl/Echo-slimme-luidsprekers-schermens/b?ie=UTF8&node=16497140031>

¹⁸ Homey - A Better Smart Home. (n.d.). <https://homey.app/en-us/>

¹⁹ Team, R. (2023). Jibo. ROBOTS: Your Guide to the World of Robotics. <https://robotsguide.com/robots/jibo>

²⁰ PCMag. (2014, August 28). Ivee Sleek Review. PCMAG. <https://www.pcmag.com/reviews/ivee-sleek>

²¹ A home that knows how to help. (n.d.). <https://home.google.com/welcome/>

Apple Homepod ²²	Enables personal requests for the use, controls the home TV, checks the temperature and humidity of the room, alerts for smoke and carbon monoxide, can be used for phone calls and as an intercom, and is connected to smart home devices.	Voice recognition	 (Apple, n.d.)
Netatmo Welcome Indoor Security Camera ²³	Secures the home security camera alerts the resident when an intruder enters the home.	Image recognition	 (Netatmo, n.d.)
Tend Secure Lynx Indoor Camera ²⁴	Recognizes familiar faces within a smart home and uses facial recognition and motion detection. Connected with the smartphone.	Image recognition	 (Amazon, n.d.)
Lighthouse ²⁵	Interactive Assistant understands your home. It can recognize people and pets and notify when specific people come and go.	Image recognition	 (Gebhart, 2018)
Canary All-in-One ²⁶	Enables real-time stream of your home, automatic night vision, and built-in speakers and microphone.	Image recognition	 (Amazon, n.d.)
Honeywell Smart Home Security system ²⁷	Connects smart home devices, uses voice control, and senses motion.	Image recognition	 (Amazon, n.d.)
Nest Cam ²⁸	Recognizes differences between humans, animals, and vehicles. Gives notifications when something unusual is happening. www	Image recognition	 (Google Store, n.d.)
Ecobee4 ²⁹	Smart thermostat adjusts indoor temperature for indoor comfort and supports the HVAC system of the building. Works with IoT voice assistants.	Decision-making	 (Ecobee, n.d.)
Arlo Ultra ³⁰	Security camera can zoom in on faces with no distortion. It is wireless and weatherproof.	Decision-making	 (Arlo, n.d.)

²² Apple. (n.d.). HomePod. <https://www.apple.com/homepod/>

²³ Slimme Binnencamera. (n.d.). Shop Netatmo. <https://shop.netatmo.com/nl-nl/security/cameras/camera-indoor>

²⁴ Amazon.com: Tend Insights Lynx Indoor 1080p HD Security Camera - Home Surveillance Monitor w/Facial Recognition, WiFi, Night Vision : Electronics. (n.d.). <https://www.amazon.com/Insights-Indoor-Security-Camera-Recognition/dp/B06XYGSD1M>

²⁵ Gebhart, A. (2018, February 22). Lighthouse cam lets you search video clips for almost anything. CNET.

<https://www.cnet.com/reviews/lighthouse-interactive-assistant-preview/>

²⁶ Amazon.com : Canary All-in-One Home Security Device - Black : Electronics. (n.d.). <https://www.amazon.com/Canary-All-One-Security-Device/dp/B014KWCCQI>

²⁷ Honeywell Home Smart Home Security Starter Kit. (n.d.). <https://www.amazon.com/Honeywell-RCHS5230WF-Smart-Security-Starter/dp/B07GR541KN>

²⁸ Google Store. (n.d.). Nest Cam (indoor, netvoeding). https://store.google.com/nl/product/nest_cam_indoor?hl=nl

²⁹ Smart Thermostats & Smart Home Devices | ecobee. (n.d.). <https://www.ecobee.com/en-us/>

³⁰ Arlo Ultra 2 Spotlight our most Precise Security Camera | Arlo UK. (n.d.). ARLO. https://www.arlo.com/en_gb/cameras/arlo-ultra-2





VELUX roof/windows blinds ³¹	Smart roller blinds can be controlled remotely.	Decision-making	 (VELUX, n.d.)
Viaroom Home ³²	Switch lights on and off, set the heating, start the washing machine, close the garage door, open and close shades and blinds, and lock the front door.	Prediction-making	 (Viaroom, n.d.)
Nest Thermostat ³³	Tracks temperature in different rooms at certain times of the day. Adjust the house's temperature based on the occupancy schedules.	Prediction-making	 (Google Nest Thermostat, n.d.)
Olly ³⁴	Home Robot with personality reads your facial expression and voice to come up with appropriate responses.	Prediction-making	 (Liu, 2017)

Table 4: Smart home devices with AI, made by author.

The array of SHDs reflects a significant shift toward enhanced autonomy, security, and user engagement within living spaces. Activity recognition functions support independent living for seniors, while data processing technologies provide secure and customizable access control. Voice and image recognition capabilities allow for more intuitive interaction with the home environment and bolster security through advanced monitoring. Decision-making features in smart thermostats and cameras improve comfort and safety by autonomously adjusting settings. Additionally, predictive technologies in various home devices proactively manage daily tasks and environmental conditions, leading to a more responsive and personalized home experience. These innovations illustrate the growing integration of AI in creating adaptive and supportive living spaces.

While the current market labels a wide range of products as 'Smart Home Devices', this classification can be misleading as it lumps together AI-enabled devices with those that lack such capabilities. To clarify this confusion, it is proposed that devices with AI functionalities be specifically referred to as 'Intelligent Home Devices' (IHDs). Adopting the IHD would facilitate clearer differentiation in the marketplace, allowing consumers and researchers to quickly identify which devices possess advanced AI capabilities. This distinction reflects the devices' ability to learn, adapt, and autonomously make decisions, which are hallmarks of intelligence, instead of devices that automate tasks based on pre-set conditions. As mentioned in Chapter 2 regarding the distinction between smart and intelligent, intelligent home devices include an understanding of the data, making them more responsive rather than following predefined rules. Therefore, for the sake of precision and to aid in developing and adopting truly intelligent systems, the term IHD should be considered and utilized in future discourse.

³¹ VELUX gordijnen 🛒 Koop ze hier met GRATIS thuis bezorging. (n.d.). Velux a/S. https://www.veluxshop.nl/?gclid=CjwKCAjwgZCoBhBnEiwAz35Rwg2aE_v4mJLNgJMZcktlhNtJ22vqazMBIqBnDEadFKLDWTFXTHVDiBoC6iQQAvD_BwE&gclidsrc=aw.ds

³² VIAROOM - Smart Home gateway with AI Viaroom Home. (n.d.). SMARTHOME EUROPE. <https://shop.smarthome-europe.com/en/box-domotique/4051-viaroom-smart-home-gateway-with-ai-viaroom-home-3770010792017.html>

³³ Nest Learning Thermostat. (n.d.). https://store.google.com/be/product/nest_learning_thermostat_3rd_gen?hl=nl

³⁴ Liu, A. (2017, October 3). Olly Smart robot AI that learns your moods - legit gifts. Legit Gifts. <https://legitgifts.com/olly-smart-robot-ai-learns-moods/>

These core clusters of IHDs are used in SH according to Guo et al. (2019):

1. Device management
2. Energy management
3. Healthcare
4. Intelligent interaction
5. Security

The "core clusters of AI functions in SH" represent the primary areas where AI is applied to enhance SH capabilities. AI manages and optimizes devices, ensuring things like lights or thermostats operate seamlessly. It also plays a role in energy management, analyzing usage patterns to save power. In healthcare, AI monitors residents' health and provides alerts or recommendations. Intelligent interaction refers to AI's ability to communicate with users, like voice assistants understanding and responding to commands. Lastly, AI can detect anomalies or unauthorized access for security, ensuring the home's safety. These core clusters highlight AI's multifaceted role in making SHs more efficient, interactive, and secure.

According to their findings, data processing emerges as the predominant AI function, while decision-making ranks as the least prevalent. This phenomenon might be attributed to ethical concerns regarding machines making decisions within SHs. Additionally, their research highlights healthcare as the sector with the most diverse AI applications, with security as the least prominent. The study emphasizes the need to discuss SHs from the perspective of architecture and human concerns. Using Google Trends to show the rapid growth of the AI industry and suggest combining it with SHT to create innovative tools. The research aims to identify the trends in SHT and products and their relationship to literature, considering the architectural context and human needs.

What stood out was Chi et al. (2020) and Guo et al. (2019) described the exact structure of AI levels. However, the difference was that Guo et al. (2019) added some fields of understanding to this structure and described the application for what it was used in customer service in the hospitality industry. The important conclusion for this thesis is the level of AI that can be applied to the levels of AI used in SHDs. These levels are visualized in Table 5. The classification describes AI in four distinct categories, each with increasing complexity: Automation employs mechanical intelligence for rule-based, routine tasks. Weak AI utilizes analytical intelligence for problem-solving and answering questions through algorithmic methods. Strong AI, or intuitive intelligence, is capable of creative thinking, adapting to new situations, and learning from past errors. Affective AI, the domain of empathetic intelligence, has the ability to recognize, understand, and influence human emotions, essentially mirroring emotional experiences similar to humans.

Different types of AI	
Automation (mechanical intelligence)	Weak AI (analytical intelligence)
<ul style="list-style-type: none"> - Rule-base - Performing routine - Performing a specific task 	<ul style="list-style-type: none"> - Solving problems - Answering questions - Using algorithms
Strong AI (intuitive intelligence)	Affective AI (empathetic intelligence)
<ul style="list-style-type: none"> - Thinking creatively - Able to adjust - Learn from mistakes 	<ul style="list-style-type: none"> - Able to recognize, understand, influence - Experiences things - Emotional intelligence

Table 5: Different types of AI, inspired by Guo et al. (2019), made by author.

The additional information related to customer services, drawing inspiration from that list Table 6 showcases an overview of different types of AI based on the smart house with a focus on health. The table outlines a classification of AI into four types by their capabilities and intended uses: Automation involves mechanical intelligence for routine tasks like housekeeping and check-ins. Weak AI, or analytical intelligence, is designed for specific tasks such as security and management, utilizing data analysis within a limited scope. Strong AI encompasses intuitive intelligence with the potential to understand and learn any cognitive task, like health monitoring and comfort control in homes. Lastly, Affective AI, or empathetic intelligence, aims to recognize and respond to human emotions, assisting in personal areas such as diet, exercise, and stress management.

Different types of AI	
Automation (mechanical intelligence)	Weak AI (analytical intelligence)
<ul style="list-style-type: none"> - Housekeeping - Check-ins 	<ul style="list-style-type: none"> - Security - Management
Strong AI (intuitive intelligence)	Affective AI (empathetic intelligence)
<ul style="list-style-type: none"> - Health monitoring - Comfort control 	<ul style="list-style-type: none"> - Diet and exercise management - Stress management

Table 6: Different types of AI with examples, inspired by Guo et al. (2019), ade by author.

Various smart house devices, such as robotic vacuum cleaners and smart house lighting systems, are available in the market, typically requiring monitoring. Security devices can be categorized as weak AI based on their specific functionality. On the other hand, strong AI encompasses comfort control, while affective AI focuses on stress and exercise management. While many smart house devices utilize weak AI, further research is needed for devices incorporating effective AI. Nevertheless, it is important to recognize that the research literature has advanced beyond the practical implementation stage. This highlights the significance of further research to ensure that these technologies are user-friendly, affordable, and practical.

2.6.5 An Insight into the Smart Home Devices Market: *Interview with Signify*

To get insight into the SHD market, an interview has been conducted with a SHD company, Signify. Signify is a global lighting company that offers various products and services for the SH market, focusing on providing innovative lighting solutions. Their offerings include smart bulbs, fixtures, accessories, sensors, and switches that can be controlled via a smartphone app or voice assistant to automate lighting and other SHDs. Signify uses AI extensively in developing its services, including its Interact IoT lighting system, research and development efforts, and supply chain management. According to its website, Signify considers AI a crucial element of its strategy to deliver innovative and sustainable lighting solutions to its customers. To gain insights into the company's approach to SH solutions, a phone interview was conducted with two channel-marketers representatives who answered eight questions related to the company's products, services, technology challenges, privacy and security concerns, AI utilization, future products and features, collaboration with architects and engineers, and contribution to the global development of SHT, with a focus on the Netherlands market. This interview is shown in Appendix A.

To summarize the interview, it was found that the current market for SHDs is primarily comprised of monitoring devices with limited knowledge and implementation of AI. One reason for this could be the novelty of the technology and the need for more familiarity among consumers. Additionally, privacy concerns surrounding smart devices, particularly those with built-in speakers, may hinder their adoption compared to devices tracking other household patterns, such as lighting. This contributes to the background question, "How does safety play a role in smart house systems?". In this interview, the valuable insight was that looking at the gathered data from a device determines its safety aspects. In this case, safety played a role in data storage. In terms of safety, smart house devices can be devised in different ways. They gather data, camera images, voice recognition, and other sensor data detection. Using light sensor data and not applying camera and voice data can make a device safer because personal information is not gathered to the extent of footage and recordings. This could be one of the reasons why the SHD market is waiting to release new SHDs with more advanced AI applications applied to them. This is outside of the scope of Building Technology as a study to focus on the philosophical and cognitive reasons for this. However, the conclusion can be made that based on the HVAC system, this is the most privacy-secure way to detect information through data other than camera vision and voice recognition.

2.7 Simulation tools

2.7.1 Smart Homes simulation tools

SH simulation tools are crucial as they offer a way to visualize and test various SH configurations without implementing them physically. By providing a virtual environment, these tools enable designers, developers, and homeowners to experiment with different setups, ensuring optimal configurations. Before deploying SHTs, these simulations can serve as a proof of concept, allowing stakeholders to understand potential outcomes and benefits.

Alshammari et al. (2017) explained that there are two main approaches for SH simulations: model-based and interactive. A Model-Based approach uses pre-defined models and activities to generate synthetic data. The interactive approach captures more interactions and fine details. Figure 15 shows that the difference between a real SH design and a simulated one is that the simulated SH can be modified after the evaluation process. However, a real SH already has an existing dataset that comes from the design and only the model creation can be modified after evaluation. The simulations help identify gaps or issues in the proposed SHs ensuring that these systems function efficiently and effectively when implemented. Given the complexity of SHTs and the integration of various devices, having a tool that can mimic real-world scenarios is invaluable. It aids in reducing costs, as errors can be detected and rectified in the simulation phase rather than after installation.

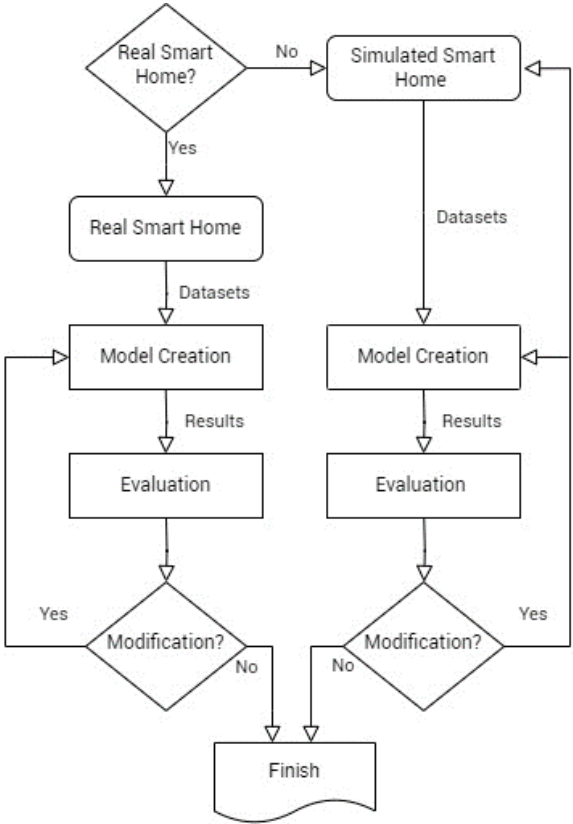

Figure 15: The workflow of real and simulated Smart Homes adapted from Alshammari et al (2017), modified by author.

2.7.2 Smart Home Devices and Open APIs

Understanding SHDs and their intelligence levels is relevant to this research. During the exploring phase of looking for options to simulate these devices in a computer before using them in real life, no websites or programs have been available to do this. One of the websites that stood out for more information about SHs and APIs was Home Assistant. Home Assistant provides open APIs (Application Program Interfaces) to interact with SHDs. Home Assistant is known for its extensive support for various smart devices and services, and it offers APIs to allow developers and users to integrate and control these devices in custom ways. Using these APIs, you can build custom application scripts or interfaces to control and monitor SHDs through Home Assistant.

An API is a set of rules and protocols that allows different software applications to communicate and interact with each other. It defines the methods and data formats applications can use to request and exchange information. In the context of SHs and IoT, APIs enable communication and control between various devices and services within a SH ecosystem (Kum et al., 2016).

Home Assistant is an open-source software for home automation designed to be a central control system for SHDs with a focus on local control and privacy (*Home Assistant*, n.d.). While its website provides valuable information about various SHDs, including configuration variables, it's important to note that Home Assistant primarily functions as a home automation platform rather than a dedicated SH simulation tool. While it can simulate specific scenarios and test automation, it does not fully replicate a SH environment without actual devices.

2.7.3 Smart Homes Raspberry Pi Home Automation System

Arora & Pant (2019) created a working Home Automation System where the AI is the system's brain and monitors the system, collects the data, and analyzes the data to make changes in the system according to the users' preferences. (Figure 16) The SH has various sensors and devices that automate tasks and enhance security, such as detecting movement, light sensors, and air quality changes. Central to this system is a controller like the Raspberry Pi, which coordinates these devices to perform actions like activating ventilation in response to bad air quality. The software aspect of the system takes over to handle the data collected by these devices. An AI plays a key role by analyzing this information to understand the user's patterns and preferences. The AI then adjusts the home's environment accordingly, such as setting the temperature for comfort or managing lighting for energy efficiency. The system is also proactive in safety, with health-monitoring devices ready to respond to medical emergencies. The entire setup allows for remote control and monitoring, allowing the user to manage their home environment from any location. It's designed to learn and adapt over time, ensuring that the home environment evolves with the user's changing needs while maintaining robust security to protect the user's data.

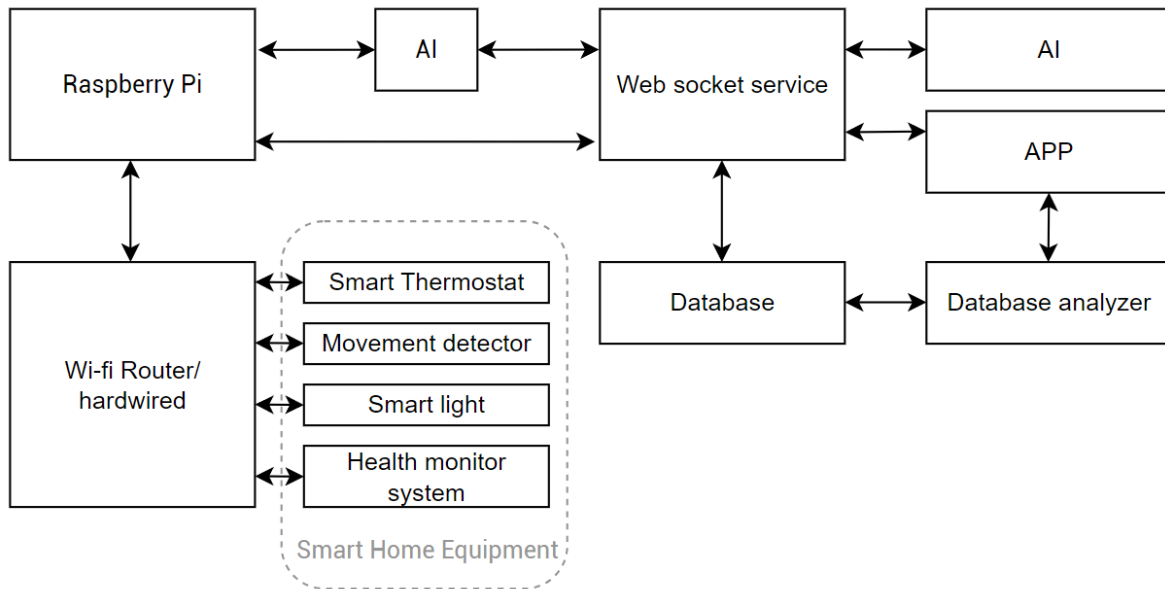

Figure 16: Home Automation System adapted from Arora & Pant (2019), modified by author.

In SH automation, the Raspberry Pi acts as the central hub, capable of creating an IoT prototype by controlling an array of sensors. With home automation platforms like Home Assistant, it becomes a powerful smart hub, enabling communication and coordination across a network of smart devices. The use of open-source code from Home Assistant and GitHub further allows for the development and simulation of diverse SH scenarios. The detailed exploration of this setup will be presented in an upcoming case study.

2.7.4 Evaluation of Environmental Conditions Simulations

The early chapters delved into the relationship between well-being and health, focusing on the assessment of various indoor climate conditions. The objective was to develop a 3D visual simulation transforming the house into a SH. Fortunately, the research benefitted from computational programming tools that enabled the simulation of the indoor climate within and surrounding the house. Ladybug Tools is a collection of free computer applications that support environmental design and education. It connects 3D Computer-Aided Design (CAD) interfaces to validated simulation engines (*Ladybug Tools | Home Page*, n.d.). In the case study, these computational tools will be explored and used for design decisions for transforming a house into a smart house. This means that through indoor climate assessment, a Grasshopper simulation can help with testing in scenarios that are impossible to test in real life, like the effect of the transformation within a house that still needs to be realized. Figure 17 displays the workflow of this climate assessment utilizing Ladybug tools. The 3D model of the house can be constructed in Rhino and linked with Grasshopper. Utilizing the capabilities of Ladybug Tools, climate visualizations and sunlight analysis can be performed, with an EPW weather file as input. Ladybug Tools enable energy simulations using Honeybee, EnergyPlus, and OpenStudio, providing insights into building energy, comfort modeling, radiance, and daylight. Additionally, the Butterfly tool can simulate airflow within and around the building using OpenFOAM.

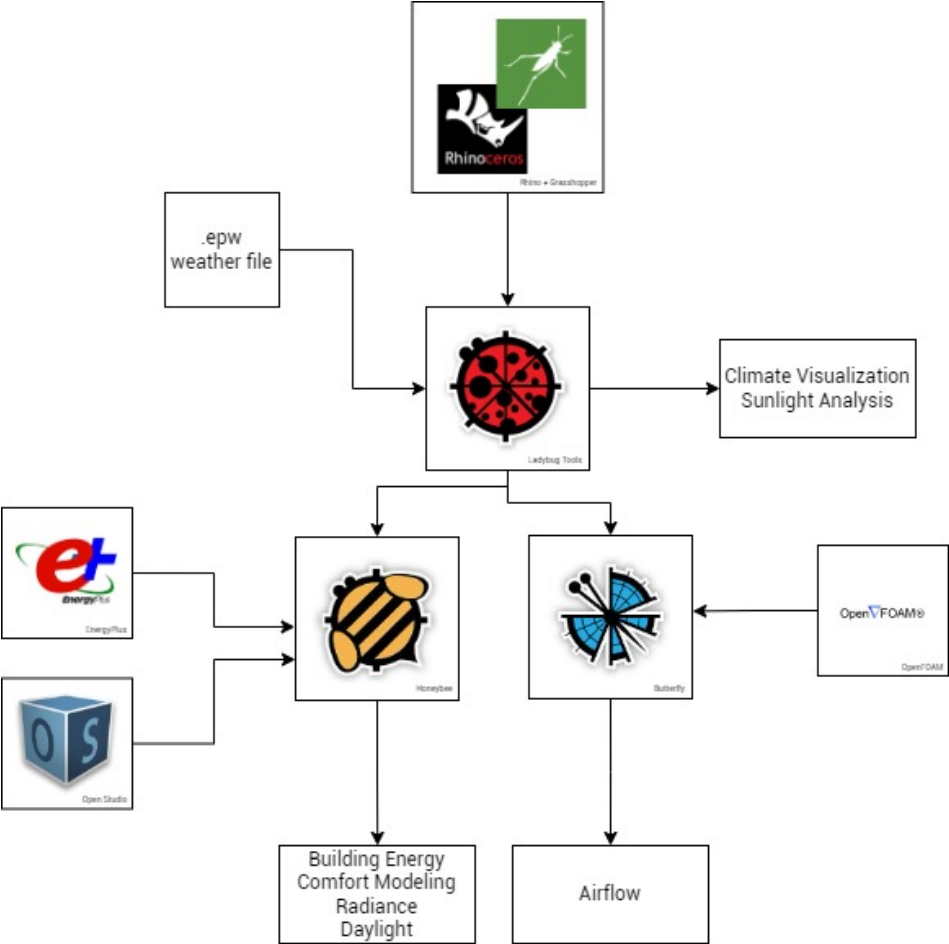

Figure 17: Ladybug tools workflow for climate assessments and simulations, made by author.

2.8 Conclusion

The evolution of SHs, marked by the integration of digitalization and the IoT, has transformed the concept of home automation into intelligent, context-aware environments. This technological shift began with the arrival of broadband internet and grew faster when smartphones became common and IoT and AI came along. This has led to homes that can automate processes, learn from user behavior, and optimize living conditions autonomously. Today's SHs stand out for their flexibility ('smartness') and capacity to respond ('intelligence') by analyzing data, ranging in complexity from basic mechanical responses to advanced empathetic understanding. Even though SHs are becoming more common, issues like expense, privacy, and safety remain. However, the ability of SHs to offer ongoing support to the elderly, helping them stay independent and healthy, is essential given the increasing healthcare costs. The role of SHs is further amplified in the vision of smart cities, where they contribute to interconnected, efficient urban living. Architectural and engineering considerations, such as sustainability features and the use of Building Information Modeling (BIM), are essential for creating intelligent and sustainable homes that can adapt to the needs of an urbanizing population.

The concept of well-being in SHs involves health, connection, and security, significantly enhancing health by boosting indoor comfort. SHDs play a crucial role in tracking and strengthening elements such as air quality, lighting, and thermal comfort that are essential for the health of residents. In places like the Netherlands, the criteria for evaluating IEQ highlight the need to counteract issues like building age, construction techniques, and outside pollution, which SHDs can tackle by fine-tuning heating, ventilation, and air conditioning systems and managing indoor comfort. The relationship between AI and SHs is evident in the effectiveness of deep learning and reinforcement learning in enhancing device functionality and security. However, there needs to be more research concerning the well-being of the 50-60 age group about SHs and AI, particularly considering the indoor environment. While machine learning approaches to predict energy consumption and optimize HVAC systems show promise, the full potential for SHs to improve indoor comfort and health is yet to be fully explored.

Integrating BIM and AI in the life cycle of buildings, including developing digital twin models and intelligent façade systems, represents a significant advancement in smart and intelligent building components. These models enable multi-criteria optimization and control, with smart façades managing energy efficiency, light, heat, visibility, and insulation. Kinetic façades, in particular, add adaptability and responsiveness to environmental changes, optimizing daylight control and contributing to thermal comfort.

SH transformations are becoming increasingly human-centered, focusing on enhancing residents' well-being, comfort, and recreation. This human-centered approach involves understanding user needs, prototyping, testing, and refining, ensuring that homes are technologically advanced, comfortable, and conducive to well-being. Integrating health-monitoring technologies turns homes into proactive spaces that contribute to the health and safety of the occupants.

However, the benefits of SHTs for efficiency, convenience, and monitoring come with privacy and security concerns. Designing systems that respect privacy, implementing robust security measures, and educating users on privacy controls are essential for creating safe and trusted

SH environments. SHTs are evolving to improve the quality of life, focusing on comfort, health, and energy efficiency. The distinction between basic automation and advanced AI integration is clear, and the industry faces challenges related to AI adoption, privacy, and safety. Future developments should address these challenges, ensuring that SHTs prioritize user privacy and security while providing convenience and efficiency.

Investigating simulation tools in creating SHs highlights their essential part in designing and improving SHs. These tools provide a virtual platform for stakeholders to visualize, test, and optimize configurations without physical implementation. The model-based and interactive approaches to simulation allow for post-evaluation modifications, offering flexibility not available in real-world setups. Platforms like Home Assistant, though not simulation tools per se, enable control and integration of smart devices through open APIs, allowing for the simulation of specific SH scenarios without actual devices. The use of Raspberry Pi for home automation exemplifies the practical application of simulations, managing a network of sensors and devices, and adapting to user preferences. Evaluating environmental conditions through simulations using tools like Ladybug Tools is crucial for assessing the indoor climate and making informed decisions when transforming a house into a SH. The knowledge gained from simulation tools sketches an evolving scene in the development of SHs, providing a preview into the future of home automation where flexibility and a focus on the user's needs are essential.

Building on these insights and informed by literature reviews and market studies, there are two primary strategies for transforming a house into a SH: the traditional and optimized approaches. (Figure 18) The conventional method involves an initial transformation of the house, followed by integrating smart devices, resulting in a standard SH. In contrast, the optimized approach prioritizes the early integration of smart devices. Valuable insights are derived by monitoring and analyzing device usage patterns, guiding the subsequent transformation of the house. This strategy ensures the home is tailored to the resident's needs, optimizing space and energy use. The benefits of this approach are:

- A personalized living experience.
- Efficient space utilization.
- Reduced energy consumption.
- Savings costs.

This approach reduces the carbon footprint and elevates the living experience, ensuring maximum comfort and convenience for the resident.

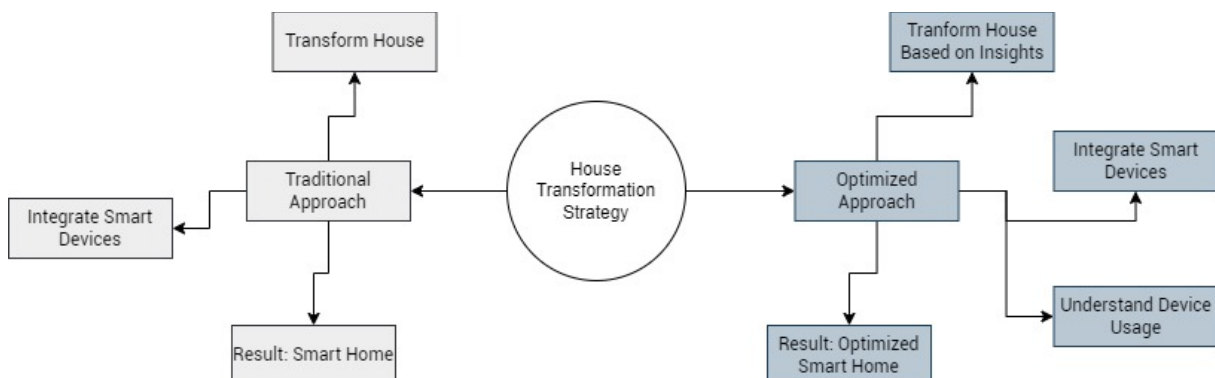
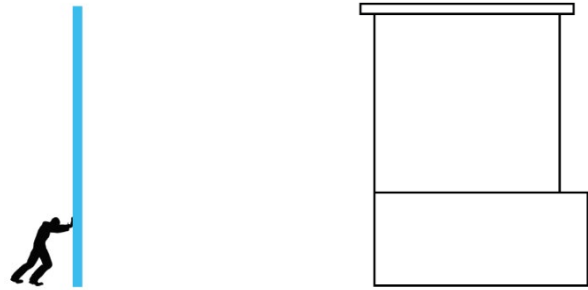

Figure 18: House transformation strategy, made by author.



III CASE STUDY

3.1 Case study

3.1.1 Introduction and Design approach

The case study presented in this thesis is a hypothetical scenario derived from a real-life context. Although the building is an existing house in the Netherlands, the resident and the transformation elements are hypothetical. The goal of this case study revolves around in-depth investigation and analysis of a particular instance, scenario, or individual to collect comprehensive insights and understandings. This case study seeks to offer a deep, detailed insight into the transformation process of houses into smart houses, exploring the nuances, challenges, and specifics that might be lost in broader research methodologies. Following this, the objective is to develop a step-by-step approach by the end of this thesis that derives from the case study. This will guide how to transform a house into a SH to improve its residents' well-being with AI's help.

Knowledge from the literature review will be applied to inform the transformation detailed in this case study. Moreover, insights from the market review will be seamlessly integrated into this thesis. The house is evaluated using a two-step approach. (Figure 19) Firstly, Ladybug tools perform a climate analysis, collecting data and conducting a design evaluation focusing on enhancing the indoor climate. The examination of the house's indoor environment determines its current condition. This assessment informs the formulation of a design. Once the design reaches readiness, a simulation predicts the potential effects of the changes. This approach ensures that the modifications enhance the indoor environment.

In the second phase, the emphasis shifts to incorporating SHDs. The goal is to transform the house into a SH. During this phase, a prototype tests a specific system, providing insights into its functionality and integration into the kinetic shading system within a Smart Home environment. The process includes continuous data collection to assess how these technologies improve the comfort and well-being of residents.

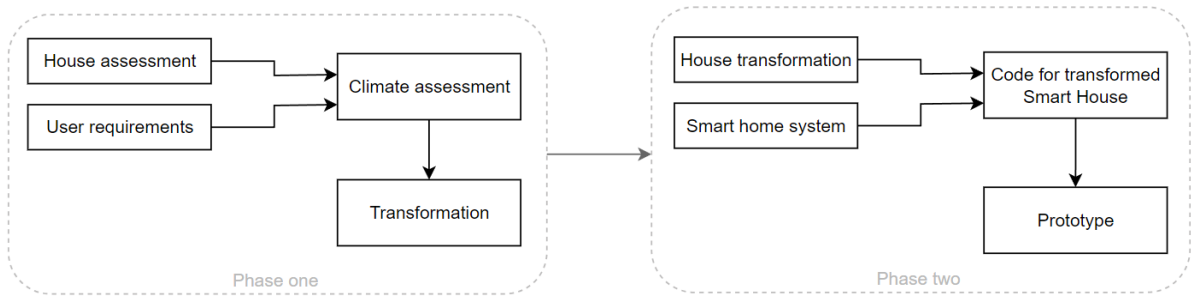

Figure 19: Workflow case-study, made by author.

3.1.2 Case Study Description

The case study involves a hypothetical resident, a 60-year-old male living in the suburbs of the Netherlands in a semi-detached house with a history of health issues. The main objective is to transform an existing house into a SH using AI technology to improve the resident's well-being. Doing a simulation for this case study to measure the outcomes of the hypothetical transformations is one of the objectives of this case study. This case study will develop a proposed guideline for transforming an existing house into an SH to improve the well-being of its residents by looking at a hypothetical scenario and the steps needed to transform the house into a SH.

Location of the case study

The location of the case study is Hoogeveen, a city in the municipality of the Netherlands, show in Figure 20. The municipality of Hoogeveen is in the south of Drenthe. The municipality has more than 56,000 inhabitants and consists of 9 villages and the main town of Hoogeveen. The municipality has an area of 129 km². (*Over Hoogeveen - Gemeente Hoogeveen, n.d.*) The city of Hoogeveen can be divided into 19 neighborhoods. In 2023, Hoogeveen's population reached 40,615, witnessing a growth of 2,57%. The predominant age demographic in Hoogeveen is the 45-65 age group. The housing landscape in the city is majorly characterized by single-family homes, which make up 68% of the residences, and of all the homes, 56% are owner-occupied (*Woonplaats Hoogeveen in Cijfers En Grafieken| AlleCijfers.NL, n.d.*).



Figure 20: Hoogeveen and neighborhoods, underlayer from Google Earth, modified by author.

The history of Hoogeveen is tied to peat extraction since 1551. Roelof van Echten played a key role in merging peatlands in 1631, marking the start of the peat industry. For 250 years, Hoogeveen was a major turf producer, impacting life and the landscape. A canal system was developed for drainage and turf transport. Hoogeveen became the largest turf producer in

Drenthe and later in the country. In the 20th century, canals were filled, facilitating road development. Industries like Philips and Unilever boosted the economy. Growth was substantial, but it slowed down in the 1980s. A municipal merger in 1998 and the Erflanden residential area led to an increased population, stabilizing around 55,000 residents (*Historische Kring Hoogeveen, n.d.*).

Within the location, a random selection is chosen for the house, and the geographic coordinates of the randomly chosen selection are shown in Figure 21. The case study's house is located within the Erflanden neighborhood, marked as number 10 in Figure 20. Between 1990 and 2000, 161 houses were constructed in this neighborhood. From 2000 to 2021, an additional 821 houses were built, and during the decade from 2010 to 2020, 215 more houses were added. As of 2020 and beyond, 22 more houses have been built. In 2023, the neighborhood witnessed a 13% increase in population compared to 2013. The neighborhood welcomes young workers, families, students, and people from different cultures. The predominant age group in the neighborhood is the 45-65 age group. Among the houses in the area, 72% have received an energy label of A, while 26.1% have been assigned an energy label of B (*Buurt Erflanden (Gemeente Hoogeveen) in Cijfers En Grafieken| AlleCijfers.Nl, n.d.*).



Figure 21: Neighborhood Erflanden and random selected house for case study, underlayer from Google Earth, modified by author.

The house

The chosen house is a semi-detached house. In the Netherlands, semi-detached houses are a common residential structure and play a significant role in the housing landscape. These houses, which share one common wall with an adjacent property, are often seen as a middle ground between detached and terraced homes. There are eight million houses in the Netherlands, including around 700 thousand semi-detached houses; this means 8.8% of the houses in the Netherlands are semi-detached (*Woningvoorraad; Woningtype Op 1 Januari, Regio, n.d.*). An average Dutch person has around 53 square meters of living space. Elderly people have a higher living space compared to other social groups (*Nederlanders Hebben Gemiddeld 53 Vierkante Meter Woonoppervlakte - Vastgoed Actueel, n.d.*). For this case study, the semi-detached house included 145 square meters.

Figure 22 displays the existing house, with the left side representing the house under consideration for the case study. The neighboring houses share the same architectural style and housing type. The house has three floors, five rooms (four bedrooms), one bathroom, one separate toilet, a kitchen and a garage. The house was constructed in 2004. The house has roof insulation, HR glass, wall insulation, floor insulation, a heating boiler, and partial underfloor heating.



Figure 22: Semi-detached house, picture from Google Maps (n.d.)

Figure 23 displays floorplans modified from the drawings sourced from Funda (n.d.) of the identical building type.



Figure 23: Floorplans of the house from Funda (n.d.), modified by author.

The 3D model is made in Rhino and shows the building's North, East, and West façade within the context, shown in Figure 24 and Figure 25.

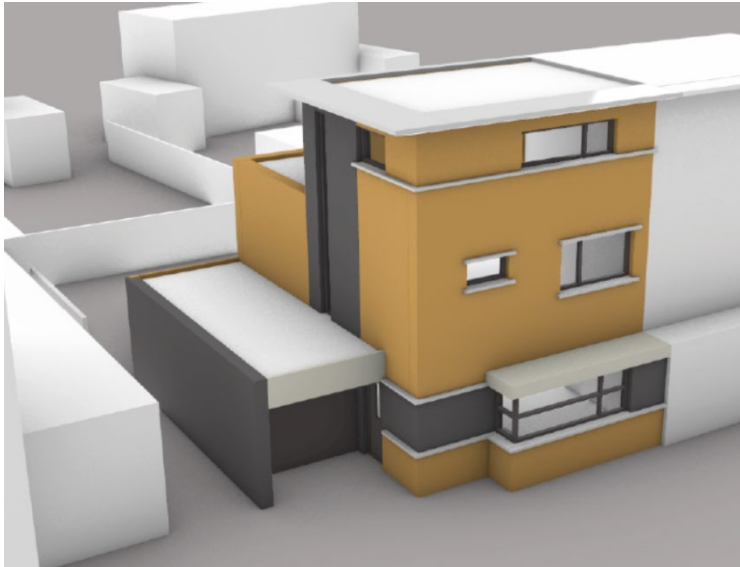

Figure 24: Frontside 3D Rhino model of the current house, made by author.

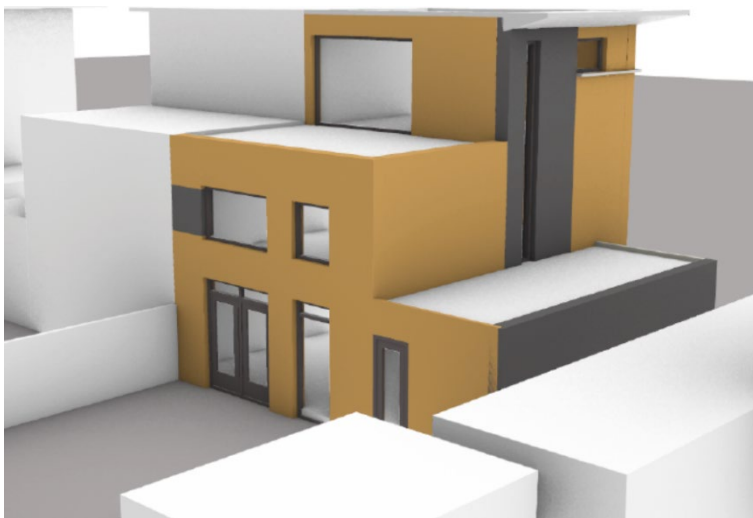

Figure 25: Backside 3D Rhino model of the current house, made by author.

The façades of the houses are to be constructed using baked-facing bricks in two colors. Prefabricated concrete bands are incorporated in the front and side façades' masonry. The façade detail is shown in Figure 26.

The inner leaf of the cavity walls of the front and rear façades are to be made of calcium silicate blocks and insulated within the cavity using insulation boards. The insulation value of the closed exterior walls of the houses is to be $R_c = 3.5 \text{ m}^2\text{K/W}$.

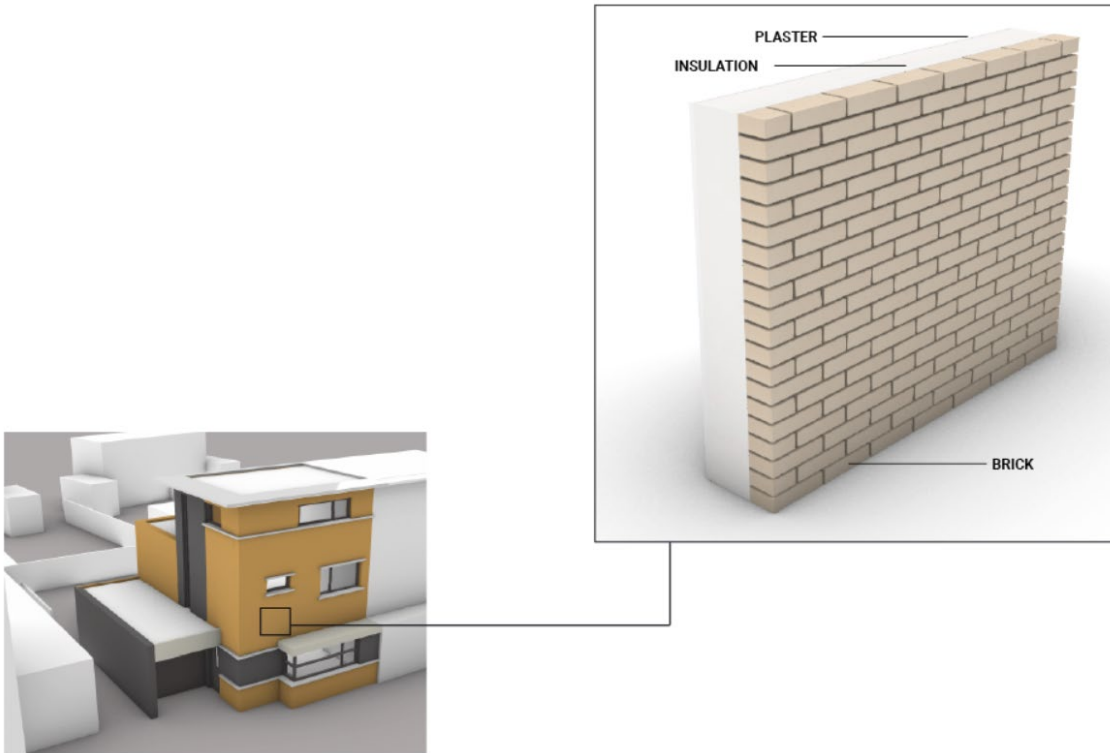

Figure 26: Construction of the outside walls, made by author.

The construction of the house features a robust foundation consisting of reinforced concrete foundation beams supported by concrete piles or reinforced concrete foundation strips. Moving upwards, the ground floor is established with an insulated system floor, boasting an impressive insulation value of $R_c=3.5 \text{ m}^2\text{K/W}$, ensuring energy efficiency and comfort within the living space.

The design continues to the upper floors, constructed using a concrete system floor, maintaining consistency and structural integrity throughout the building. The roof, a critical component of the house, is meticulously crafted as a concrete system floor for the base, followed by a well-insulated roof box, and finally, covered with a layer of bituminous roofing for maximum protection. The interior side of the roof is neatly finished with gypsum boards and a layer of spray work, adding to the aesthetic appeal and functionality of the space.

To ensure privacy and sound insulation between individual living units, the partition walls are constructed using calcium silicate blocks, following a carefully planned anchorless structure. Additionally, the inner leaf of the cavity walls is constructed using calcium silicate blocks, providing further stability and insulation to the structure. This design choice provides stability and contributes to the overall comfort and quality of living within the house.

Resident requirements

Kim et al. (2020) underscore the necessity of tailoring SH solutions to meet the specific needs of various age demographics, aiming to enhance health, well-being, and social interactions. They advocate for a multidisciplinary approach and a commitment to the pragmatic and impactful application of SHTs. The literature highlights the imperative for a human-centric design in transforming a residence into a SH, with the understanding that the configuration of such a home would be distinct for each individual. Agee et al. (2021) highlight the importance of this method for optimizing human well-being and the functional efficiency of smart buildings, ensuring that the technology benefits the resident and improves their living standards. The design process should prioritize a system that addresses residential needs and enhances well-being, ensuring user-friendliness and intelligent functionality.

In this hypothetical scenario, the resident experiences occasional social isolation, tires easily due to previous health issues, and lacks physical activity. There is a clear opportunity to promote a healthier lifestyle, encouraging physical activities and social interactions to address the resident's physical and mental health needs. The resident's goal is to modify the home to better support aging in place. This would entail integrating health care and management systems within the home and implementing crisis recognition features that can alert family members in case of emergencies. This approach aligns with the principles outlined by Kim et al. (2020), ensuring that the SH solutions are customized to the resident's unique needs and contribute positively to their overall quality of life. Table 7 outlines the requirements of this resident.

Resident type	Character	Physical ability and health condition	Living and activities
Middle-aged resident	60 year-old resident, working, living alone.	Has a history of illness, has been concerned about his health, and feels lonely.	Not used smart devices but is open to learning it. Works fulltime

Table 7: Resident's requirements, made by author.

Daily challenges such as household difficulties, low physical activity, and social isolation require a holistic approach. Enhancing family interaction, providing health care access, and automating routines through technical solutions can make a significant difference. Devices for health management, activity tracking, and virtual assistance, alongside spatial solutions like personalized exercise areas and automated facilities, create a supportive living environment. These integrations ensure a balanced lifestyle, promoting well-being and social connectivity. Building on this, the house must be transformed by prioritizing a comfortable indoor environment. Devices within the home should actively monitor and adapt to these conditions, ensuring continuous optimization. This involves tracking factors like air quality, temperature, humidity, and lighting and adjusting them in real time to maintain an ideal living environment. This adaptive approach not only enhances comfort but also contributes to the overall well-being of the residents, making the SH not just a place of residence but a dynamic space that actively contributes to the health and happiness of its occupants. Table 8 details the potential technical and spatial solutions in response to the users requirement.

Issues	Low physical activity Social isolation Low strength and tires easily
Need	Family interaction Social implication Health care and consultancy Automation of daily routines
Technical Solution	
Function	Health care and management Recognizing crisis Assistance Activity tracking and alarm Health check and care smart device
Devices	Indoor comfort Voice talker/secretary Virtual trainer Smart home devices for tracking the indoor environment
Spatial solution	
Unit and design	Personal exercise space Remote workspace Meeting space
Common space	Exercise space Rest area Health measurement space

Table 8: Possibilities for technical and spatial solutions, made by author.

House requirements

Passive House stands out as a highly effective strategy for reducing the energy requirements of buildings, championing the adoption of energy-efficient building technologies, and striving for environmental sustainability. The central goal of the Passive House approach is to enhance or maintain a high-quality indoor environment, focusing on IAQ and thermal comfort while minimizing energy use and associated costs. Notably, achieving the Passive House standard is possible with various materials, design philosophies, and technologies. (Onio Figueiredo et al., 2016)

Transforming a house into a SH presents an opportunity to create a highly energy-efficient building, incorporating a blend of passive design, hybrid, and active energy solutions. This aligns with the principles of Passive House, a strategy renowned for significantly reducing a building's energy requirements while ensuring a high-quality indoor environment, focusing on IAQ and thermal comfort. Heinzerling et al. (2013) mentioned the requirements of a IEQ for a healthy buiding, which are considered in this transformation.

To further enhance the energy efficiency of a building to optimize its energy performance, conduct a precise energy audit to identify specific areas for improvement. Focus on targeted upgrades such as enhancing insulation in certain areas, upgrading to more energy-efficient windows, and improving air tightness. Optimize existing HVAC and lighting systems for peak performance and consider integrating renewable energy sources like solar panels. Implement smart building technologies for real-time energy usage monitoring and optimization, ensuring the building meets and exceeds energy efficiency standards.

In terms of passive design, the building's orientation will be analyzed to maximize the impact of transformations. The house's envelope, including the walls' mass and natural ventilation, will be optimized. A potential green roof can further enhance energy efficiency and indoor comfort. The design of the building envelope is crucial, acting as a filter between outdoor and indoor climates. Key factors in this design include:

- 1. Insulation: To reduce heat loss in cold seasons and heat gain in warm ones.
- 2. Solar Gain: Influenced by insulation levels, building shape, orientation, and the implementation of glazing, shading systems, and devices.
- 3. Thermal Inertia: Depending on the mass and material of the envelope.
- 4. Ventilation: To control air exchanges with the outside, enhancing IAQ.

The building will incorporate passive design strategies for example implementing a green roof. To enhance natural ventilation, open spaces can provide for the well-being of the resident, ensuring that windows on the south and north façades are directly opposite. Hybrid solutions are explored via active solar shading, incorporating elements like the kinetic façade principle. Solar panels will be installed for active energy solutions, utilizing photovoltaic cells to transform sunlight into electricity and heat directly. The following chapters will delve deeper into evaluating the indoor and outdoor climate of the case study, developing design principles, and concluding to guide this transformation towards sustainability and smart living space.



3.1.2 House and Climate Analysis

Analysis of the spatial organization

The house can be divided into two distinct areas: the living area, where guests are welcomed, and the private area, exclusively used by the resident. The ground floor is the living area, and the first and second floors are the private areas. In Figure 27 the yellow mark shows the private zones of the existing house, and the blue marked area shows where guests are invited. To keep the privacy of the resident this division between private and non-private areas will stay the same.

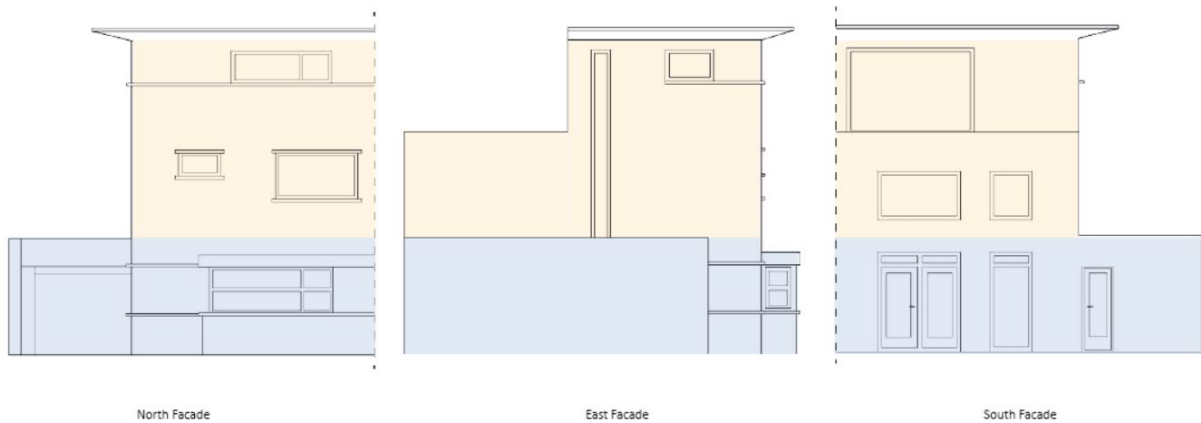

Figure 27: Private area vs living area, made by author.

Enhancing the special relationship within the building and upgrading its current usage could be beneficial. The living room and kitchen have a good connection because of the open space, but the bedrooms and bathrooms are the only used rooms on the first floor. (Figure 28) There is a potential on the first floor that could be designed as an open space to create more flow in the house. The second floor remains unused, presenting the potential for transformation and utilization. One bedroom of the house on the right side of the first floor is not used. The bedroom on the second floor is used occasionally whenever family members are visiting. In the summer this space is not used because of the unsuitable indoor climate on the summer days.

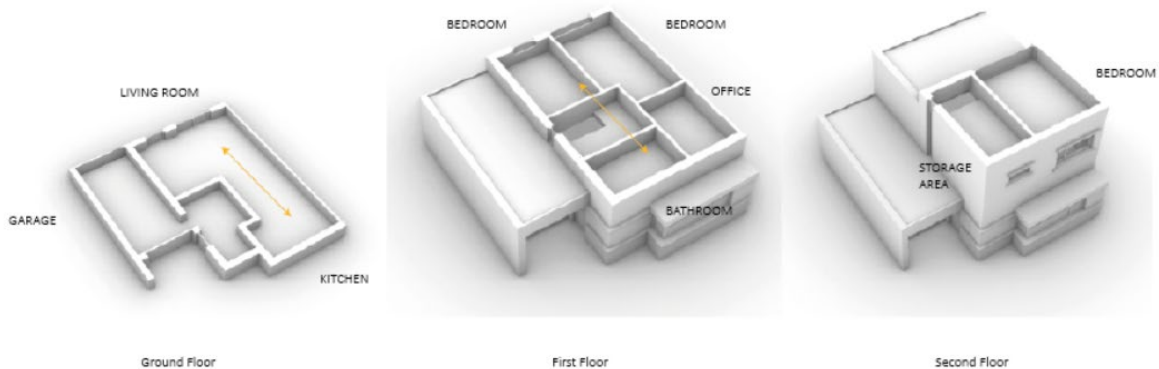

Figure 28: Open spaces and possibilities for open spaces, made by author.

Figure 29 illustrates the interconnections and relationships among the most frequently used areas of the house and the spaces that do not provide the proper function for the resident. The house has three bedrooms, and one resident uses it. The yellow shows the most used areas of the house, and the blue shows the most used areas. Enhancing the space's usage will be considered in the transformation.

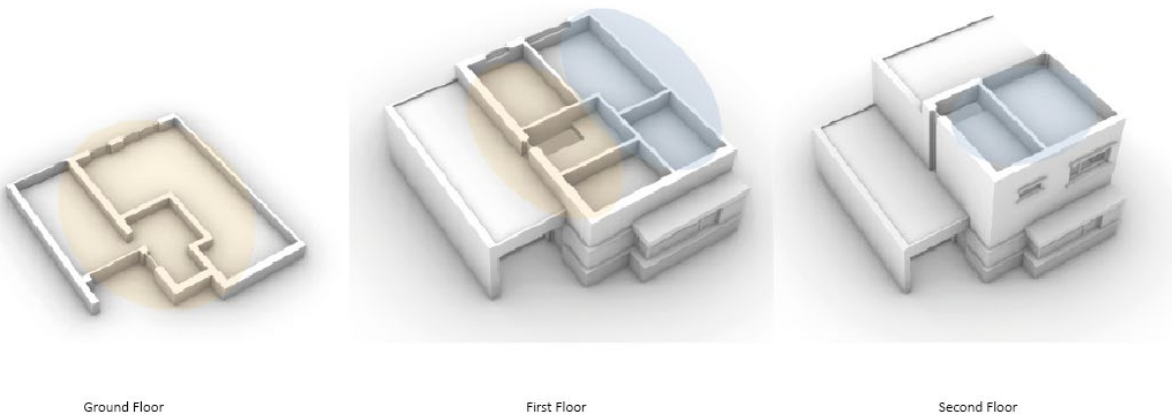

Figure 29: Most used spaces vs least used spaces, made by author.

Upon examining the day and night time schemes of the existing programs within the building, it is evident that the living room, kitchen, bathroom, and office primarily serve daytime functions, while the remainder of the house is designated for nighttime use. The yellow marked spaces in Figure 30 show the day areas, and the blue areas are the night areas of the house. The design will need to create alternatives to this program distribution. Transforming the house could mean reorganizing the day and night areas; for example, applying more outdoor spaces, which could be used during the day, will make the resident more active within the different areas of the house and make the resident use these areas more.

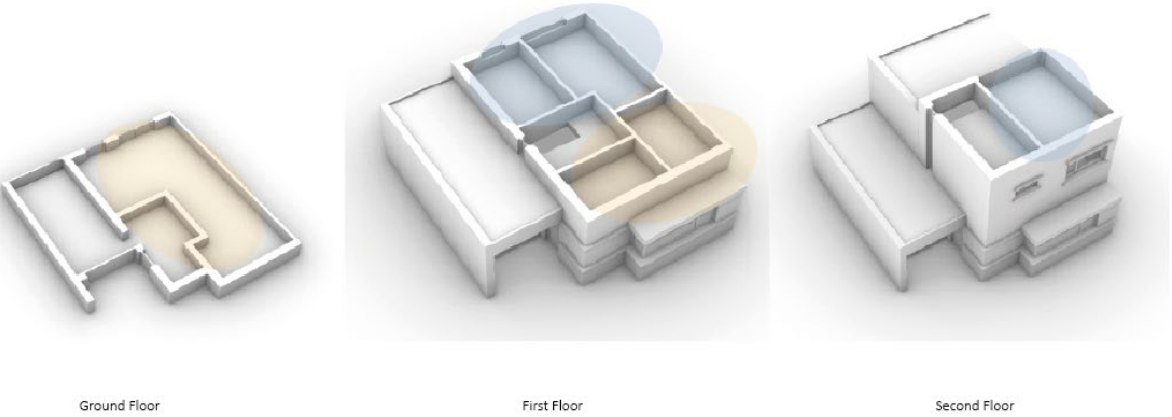

Figure 30: Day-areas vs night-areas, made by author.

The goal of transforming the house into a smart house would be to make more interconnected spaces where devices and systems are linked together to share information and resources and where functional spaces are applied to the house to allow more movement and physical usage. Transforming the house into a smart house would mean the spatial relationship would change, as shown in Figure 31. The house will have sensors for tracking the resident and the indoor climate, such as air quality, temperature, and humidity levels. These continuous monitor devices will track the residential behavior within the whole house. This means that the house will be more interconnected than a non-smart house.

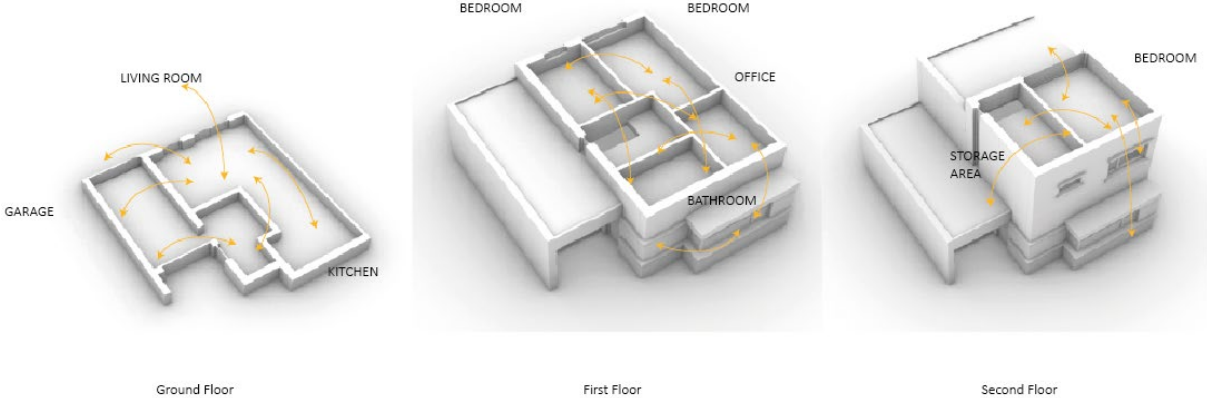

Figure 31: Spatial connections of the smart house, made by author.

In terms of the day and night analysis and the use of the house, transformation to a SH will make the house more connected, used, and optimized. This means that whether it's daytime or nighttime, the home adjusts lighting, temperature, and other settings to match the occupants' activities and schedules, ensuring the house is as comfortable and energy-efficient as possible at all hours, as shown in Figure 32.

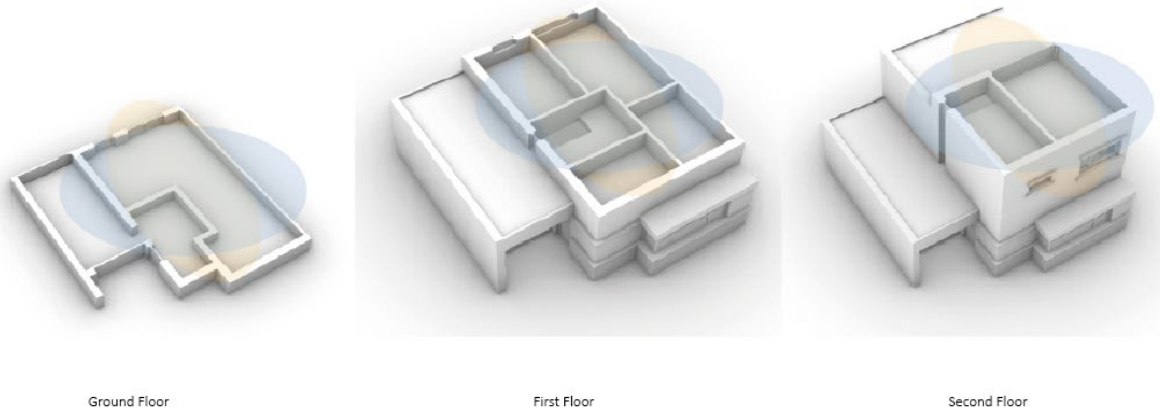

Figure 32: Day and night relationship and optimal use of the house, made by author.

Exploration Ladybug Tools for Climate Assessment

Before making transformation and design choices for the house, being familiar with the area's unique climate is crucial. This knowledge ensures that the project is environmentally friendly and that it meets the unique needs and challenges of its location.

In Hoogeveen, where the project is set to take place, the climate plays a significant role in shaping the project's direction. An EPW weather file collects accurate weather data, offering a comprehensive view of the area's climate. (*EPW Map*, n.d.) This file serves as a foundation for a more in-depth climate analysis. Ladybug Tools is then used to evaluate the indoor and outdoor climates. The insights gained from this assessment are invaluable, guiding the design choices and ensuring the project's success in its specific environment.

Based on the climate analysis data, the representative weeks for each season are:

- Winter: January 6th to 12th
- Spring: March 29th to April 4th
- Summer: July 20th to 26th
- Autumn: October 27th to November 2nd

The week from January 13th to 19th is the coldest, while August 24th to 30th marks the hottest week. The region falls under the ASHRAE Zone 5C classification. This designation, set by the American Society of Heating, Refrigerating, and Air-Conditioning Engineers (ASHRAE), offers guidelines for HVAC design and promotes energy efficiency in buildings. Specifically, Zone 5C indicates a cool marine climate with moderate temperatures year-round, influenced by a nearby ocean or significant body of water.

The predominant wind speed originates from the Southwest region throughout the year. Figure 33 illustrates the wind speed and wind roses. In winter, the prevailing wind direction is from the South. During spring, it shifts between the West and the Southeast. In summer, the wind primarily comes from the South and North, while in autumn, it predominantly blows from the Southwest. The script of this climate analysis is show in Appendix B

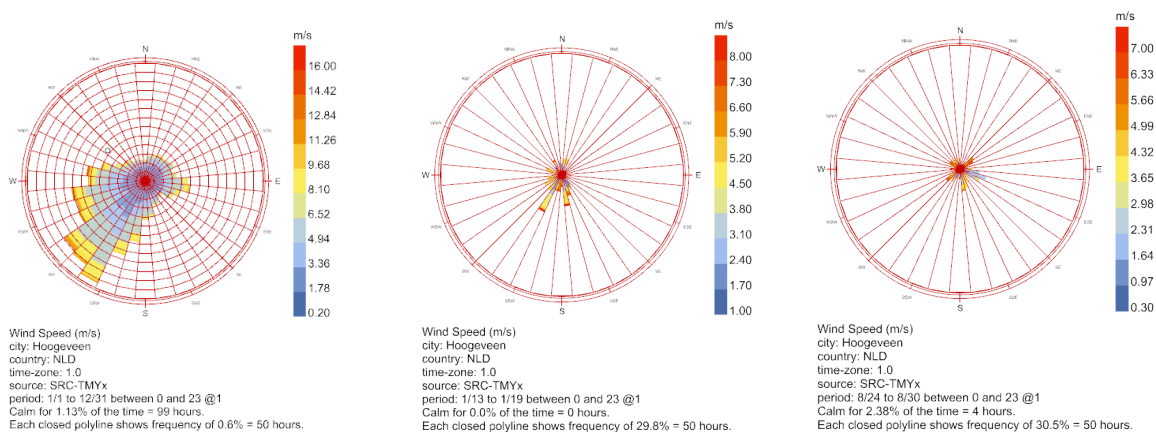

Average yearly windspeed

Coldest week

Hottest week

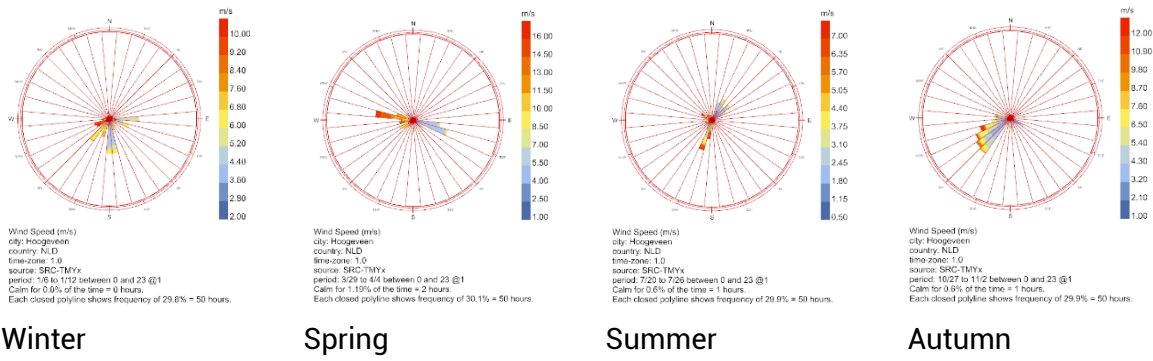

Figure 33: Windspeed throughout the year using Ladybug Tools, made by author.

Wind analysis within the context

The context for this analysis was sourced from CADMAPPER (n.d.), shown in Figure 34, but the house has been adjusted to represent its space accurately and with greater detail. The wind simulation was conducted using Ladybug Tools: Butterfly. Butterfly serves as a plugin and a Python library, enabling the creation and execution of advanced computational fluid dynamic (CFD) simulations through OpenFOAM.

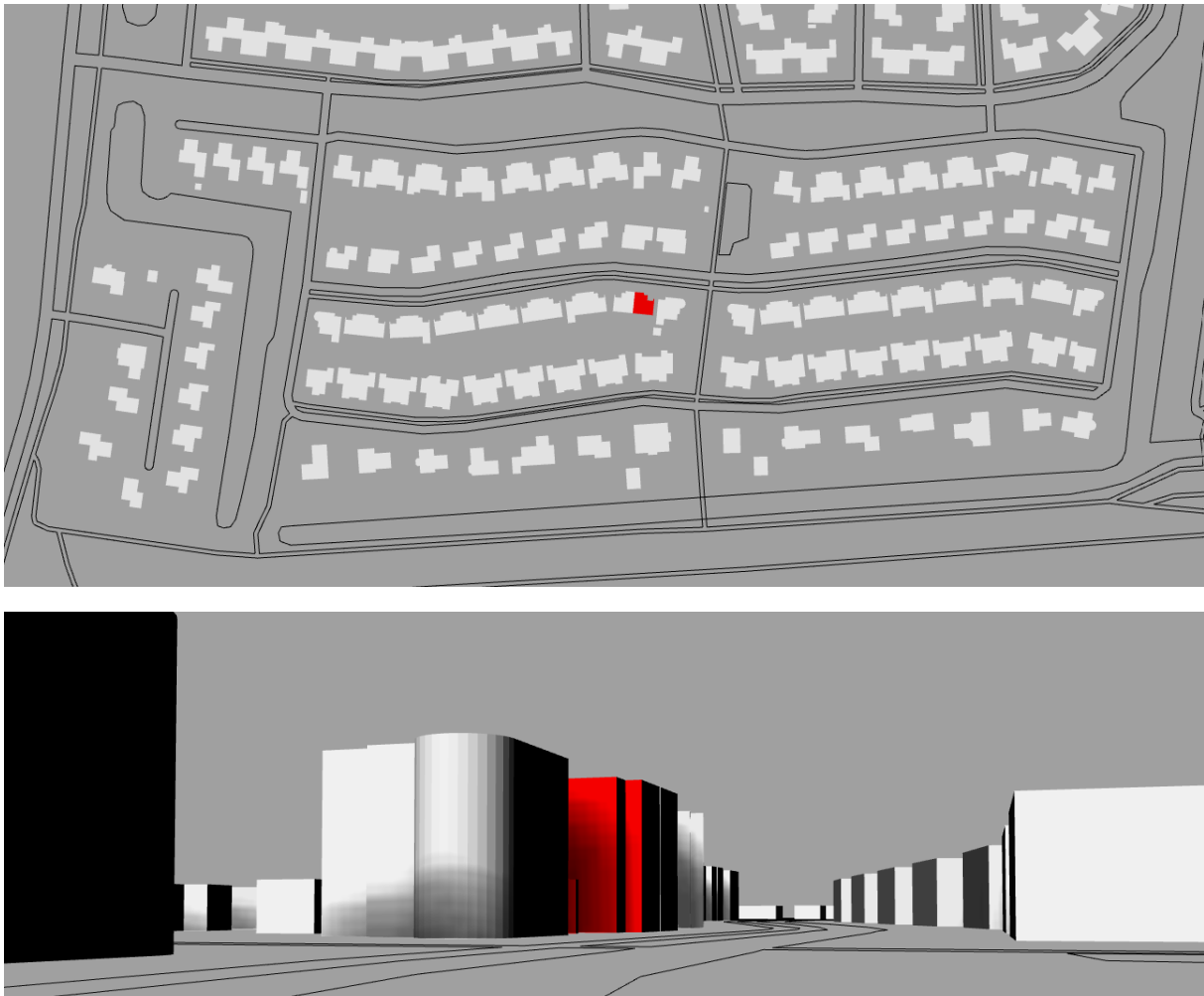

Figure 34: Context of the analysis, model from CADMAPPER (n.d.), applied by author.

The outcome of the contextual wind analysis, shown in Figure 35, shows the influence of the surrounding building on the heatmaps and the wind velocity. Appendix B displays the script for this analysis. Evaluating the airflow and heatmaps within the building's context provides valuable insights into its interaction with its environment. The 3d model of the existing house and its neighboring structures were extracted from the CADMAPPER model of the neighborhood. This allowed for a focused examination of how these buildings influence the airflow and temperature distribution around the house. The simulation's findings indicate that the surrounding structures play a significant role in modulating the wind direction and speed around the building. Specifically, the wind velocity between the buildings is slower, highlighting the protective or buffering effect of the neighboring structures. This understanding can guide design decisions to enhance the building's comfort and energy performance.

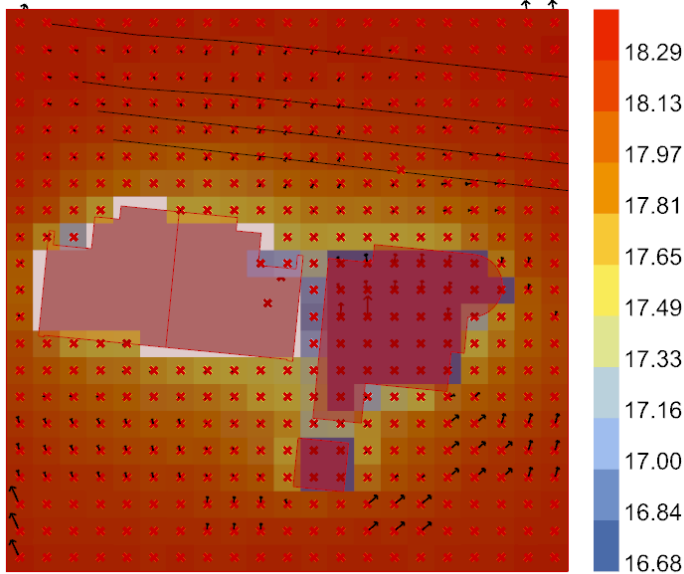

Figure 35: Wind-analysis Ladybug Tools, using Butterfly, made by author.

Direct Sun Analysis within the Context

To ensure that the specific environmental conditions inform architectural and design decisions of a location, a detailed simulation using Ladybug Tools was conducted for the chosen site. The sun analysis script is adapted from TOI-Pedia (n.d.). This simulation provides insights into the direct sun hours the building receives, which plays a pivotal role in determining its energy efficiency and comfort levels. The results of the simulation are shown in Figure 36. The rooftops receive approximately 4,442 hours of direct sunlight annually. The south-facing façade gets 3,100 hours, the east-facing façade benefits from 2,220 hours, while the north-facing façade has the least with 800 hours. This script is shown in Appendix B.

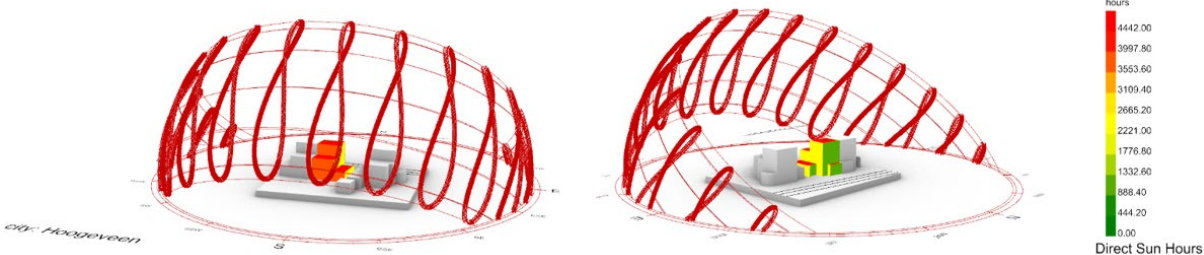

Figure 36: Direct sun-analysis using Ladybug Tools, made by author.

Given the substantial sunlight exposure on the rooftops, installing solar panels would be a strategic move to capture solar energy. The façades, particularly on the south and east sides, receive significant sunlight. To manage this, adjustable shading devices can be used to modulate the sunlight entering the building, helping to diminish glare and maintain a comfortable indoor temperature. Additionally, green walls can serve as natural insulators, absorbing sunlight and cooling the building. Incorporating windows on the south façade is a beneficial approach for the winter months. These south-facing windows can harness the lower winter sun, allowing more natural light into the building and reducing the reliance on artificial lighting. Moreover, the sunlight entering through these windows can naturally heat the interior, decreasing heating expenses and overall energy consumption.

Indoor natural airflow

The primary focus is to understand the natural airflow within the building, particularly on the second floor. The Butterfly script, a crucial tool in this environmental analysis, is employed for detailed examination. The second floor has large, non-opening windows on the south façade, making it essential to study the airflow dynamics, especially given the limited windows on the North and east façades. Analyzing the airflow with the Butterfly script helps visualize its impact on the second floor's temperature distribution and explore the potential benefits if the south façade had openable windows or doors.

Currently, there are two openable windows on the second floor. Using Butterfly, the airflow dynamics with these windows are illustrated. Additionally, a Ladybug component is utilized to display the associated heatmaps. The findings indicate that the primary airflow direction is from the North, moving towards the East of the building. However, the heat maps suggest that the space is warmer than desired. This simulation is shown in Figure 37 and the script is shown in Appendix B.

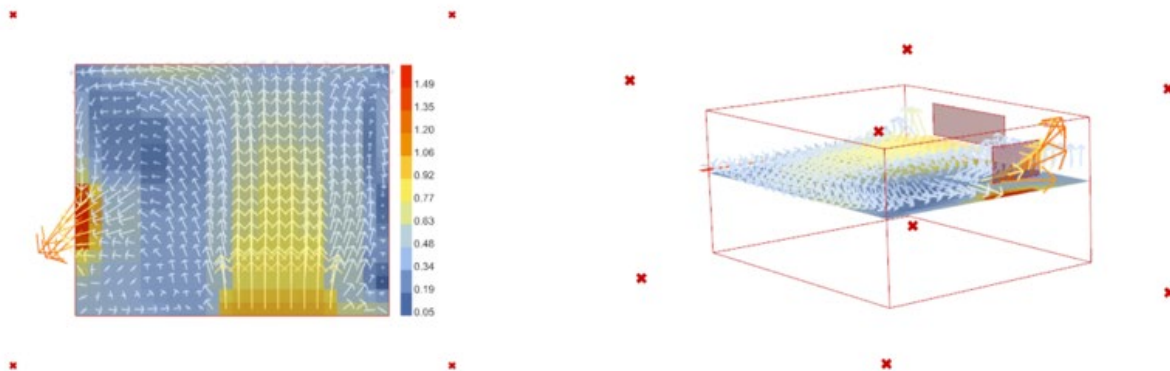

Figure 37: Airflow dynamics and heatmap on the second floor, made by author.

The following simulation introduces a larger window on the south façade, simulating its potential for the inside airflow. (Figure 38) The results show a reduction in the interior's heat levels. This simulation was conducted without considering an interior wall. The upcoming analysis will factor in this wall to understand its influence on airflow dynamics. Upon comparing the two scenarios, the three-window configuration offers a more thermally comfortable environment than the two-window setup. The parallel positioning of the windows ensures smoother airflow, reducing air velocity, enhancing ventilation, and creating a more comfortable heatmap.

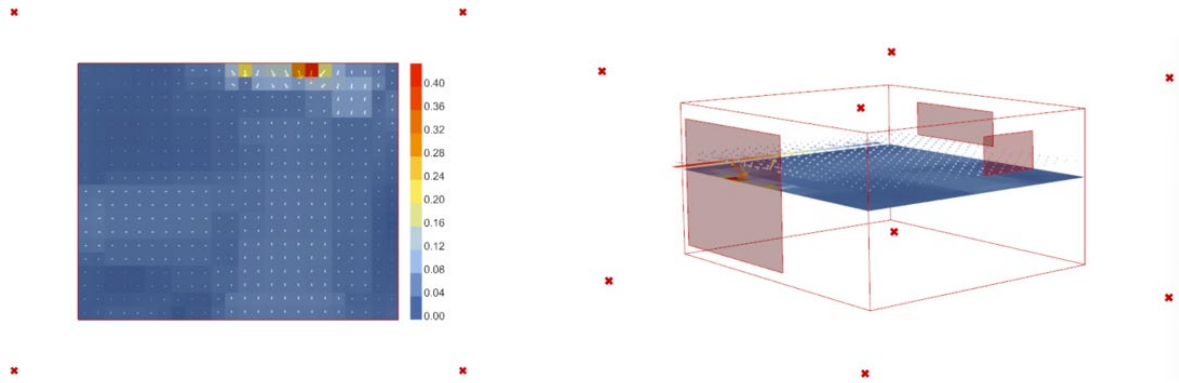

Figure 38: Airflow dynamics and heatmap with openable windows on South façade, made by author.

Conducting a thorough wind flow simulation helps gain a comprehensive understanding of the wind patterns inside the building and evaluate whether adjustments to the internal partitions are required. This simulation will highlight the interior wall's effect on airflow, with the door being open to ensure maximum airflow. Considering the summer wind predominantly comes from the South, the largest south-facing window is designated as the primary inflow point, with other windows serving as outflow points. This simulation provides a clear visualization of the airflow patterns within the building, offering insights for potential design modifications, which are shown in Figure 39.

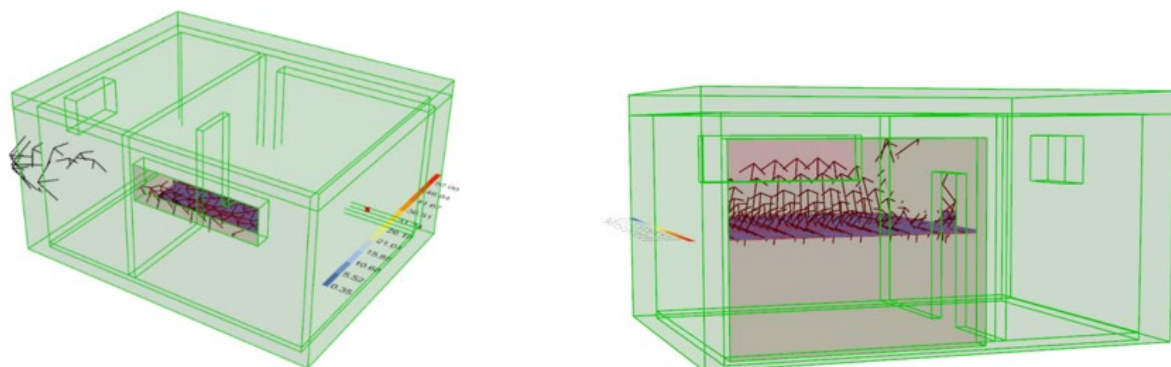

Figure 39: Detailed airflow dynamic on the second floor with the interior wall, made by author.

The comprehensive airflow analysis of the building, mainly focusing on the second floor, has provided valuable insights into its ventilation and thermal dynamics. Large, non-opening windows on the south façade and limited windows on the north and east affect the building's internal temperature. The simulations, conducted using Butterfly and Ladybug tools, have shown that introducing openable windows, especially on the south façade, can significantly enhance the building's thermal comfort. The parallel positioning of these windows facilitates smoother and more efficient airflow, reducing interior heat levels. Furthermore, including an interior wall in the simulations has highlighted its potential impact on airflow patterns. As summer winds predominantly come from the South, strategic window placements can optimize ventilation and energy efficiency. These findings underscore the importance of informed architectural decisions in creating comfortable and energy-efficient living spaces and an optimal indoor climate.

Heating, Cooling, and Lighting for Energy Use

Understanding the architectural and energy design of an existing building is crucial. The house under examination possesses unique design features that make it an interesting subject for this case study. Utilizing Honeybee Ladybug tools, the analysis explores the energy usage and the utilization of natural light within the house. Potential modifications and enhancements can be identified by examining its current state. This study provides insights into the current functionality of the house and suggests ways to make it more environmentally friendly and energy-efficient.

Honeybee Ladybug tools offer a detailed analysis of a building's energy intensity. These tools utilize Radiance for daylight simulations and employ OpenStudio and EnergyPlus for energy modeling. The system requires inputs such as the building's structure, windows, wall constructions, and flooring to achieve accurate results. Honeybee is designed to support in-depth daylighting and thermodynamic modeling, making it especially valuable during the intermediate and advanced design stages. By integrating EPW weather file data, Honeybee ensures precise outputs, allowing for a comprehensive understanding of daylight, radiation, and energy dynamics within the house.

This simulation demands more detailed information about the house than the previous ones. Linking the house's geometry from Rhino to Grasshopper occurs. Each room category is identified and linked to a built-in program within the simulation. Incorporating the building's materials and construction into the process is considered. The script generates energy simulations. Figure 40 displays the results of the simulations, and Appendix C presents the scripts.

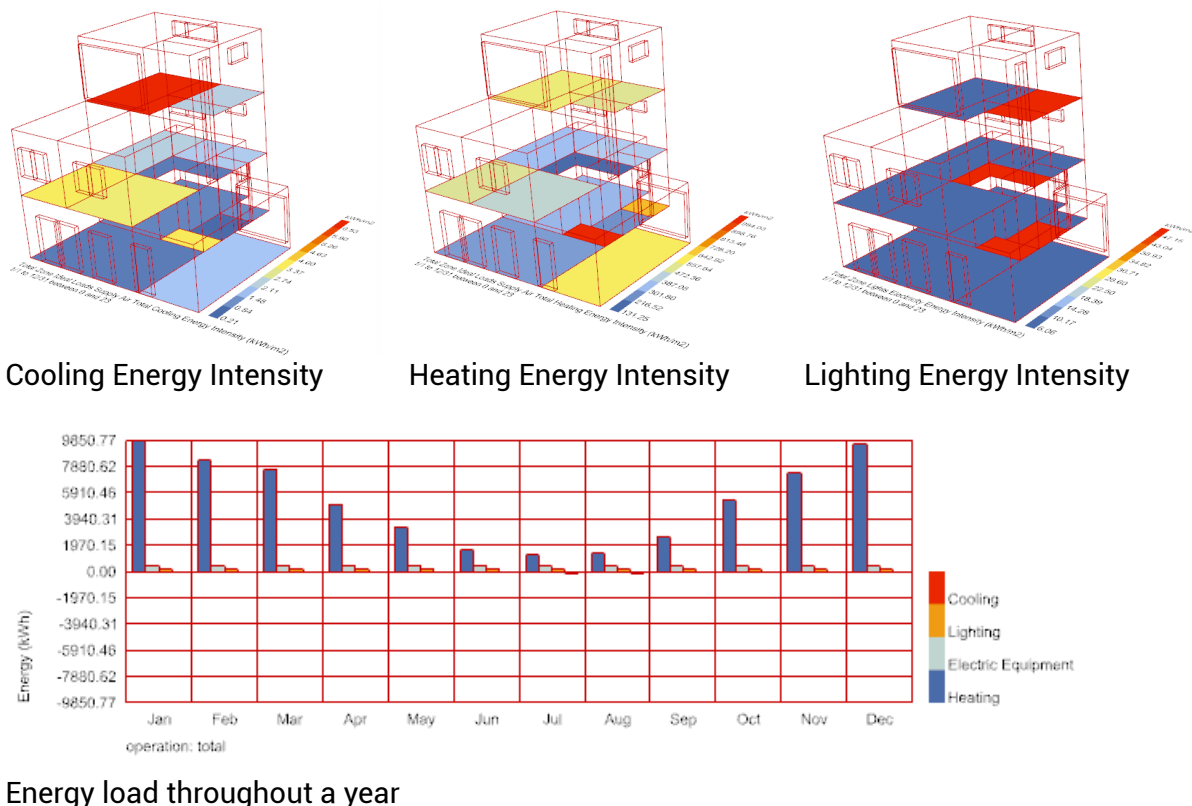

Figure 40: Honeybee energy analysis, made by author.

In Honeybee, these aspects are analyzed by considering various parameters and conditions, such as weather data, building geometry, material properties, occupancy patterns, and HVAC systems, to simulate and evaluate the energy performance of a building. The tool allows designers and engineers to optimize these parameters to enhance the energy efficiency of the building, ensuring a balance between comfort and sustainability. The next data set shows energy use in the house, measured with Honeybee Ladybug tools. The house needs more heating than lighting or cooling, mainly because of the Netherlands' mild, ocean-influenced weather. The guestroom has the highest need for cooling since its windows are closed, stopping air from moving freely in that space.

Table 9 offers a detailed breakdown of energy consumption across different areas within a building, spanning three distinct floors: Ground floor, First floor, and Second floor. Each room or area's energy consumption is categorized into Cooling, Heating, and Lighting, with values presented in kilowatt-hours per square meter (kWh/m²). This unit measures energy use in relation to the size of the space. The Cooling column represents the energy expended for cooling each space, with rooms like the Guestroom on the Second floor requiring a significant amount of energy at 6.53 kWh/m². This increased energy need is due to the large windows on the second floor's south façade, which lack a shading system to mitigate overheating. Additionally, these windows are non-opening, further contributing to the cooling demands. The Heating column indicates the energy dedicated to heating, with areas such as the Stairs on the Ground floor consuming a notable 984.03 kWh/m². This higher usage can be attributed to the stairs being designed as a distinct block within the house, separated from the corridors by an air wall. Lastly, the Lighting column displays energy due to lighting in each area. Some spaces, like Corridors, have a higher consumption, possibly because they are larger or receive less natural light. Overall, this table offers insights into the energy performance of different areas within the building, highlighting potential areas for energy-saving interventions or design modifications.

	Cooling [kWh/m ²]	Heating [kWh/m ²]	Lighting [kWh/m ²]
Ground floor			
Corridor	0.21	220.66	47.13
Toilet	0.80	658.85	6.07
Kitchen	0.66	290.71	6.07
Living room	0.50	243.13	6.07
Garage	1.58	537.33	47.15
Stairs	3.39	984.03	47.15
First floor			
Corridor	0.50	131.25	47.15
Bathroom	1.78	345.59	6.07
Bedroom	2.93	414.43	6.07
Guestroom	3.22	465.35	6.07
Office	2.02	304.99	6.07
Second floor			
Corridor	1.02	470.07	47.15
Guestroom	6.53	496.22	6.07

Table 9: Energy loads per room current house, made by author.

Point in time-based analysis for radiance

The analysis of sunlight hours revealed that the southern façade receives the most sunlight. A radiance analysis was performed to comprehend how this affects the interior heat distribution. This radiation simulation displays varying heatmaps based on the sun's position at 9:00, 12:00, 15:00, and 18:00 hours. The chosen dates correspond to typical weeks identified in a prior climate simulation. On the second floor, the room receives the most sunlight. The south façade gets the bulk of the sunlight entering the building. During autumn, the sun sits lower in the sky, allowing sunlight to enter more areas of the house. While this ensures plenty of daylight and aids in heating the rooms on cooler days, adding shades to the south façade for the summer months is recommended. This will prevent the house from overheating, especially considering the impact of global warming on extremely hot days.

	9.00	12.00	15.00	18.00
January 6 th				
March 29 th				
July 20 th				
October 27 th				

Table 10: Radiance analysis for the typical weeks of the year, made by author.

Findings of the analysis

The findings of the analysis done within this chapter are as follows:

- *Redesign underused spaces:* Improve first and second floors for better usability.
- *SHT:* Use sensors for enhanced climate and behavior monitoring.
- *Tackle indoor heat:* Address excessive summer heat for poorly ventilated areas like the second floor, possibly by redesigning the south façade.
- *Enhance natural ventilation:* Consider openable windows for better airflow, especially on the second floor.
- *Sunlight management:* Utilize direct sun analysis for solar energy potential and shading strategies.
- *Energy efficiency emphasis:* The design should focus on heating optimization and solar energy utilization.

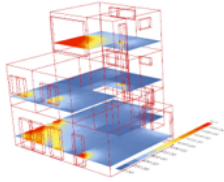
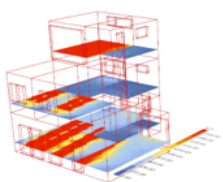
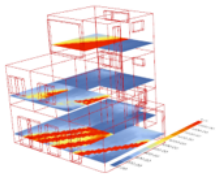
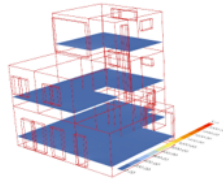
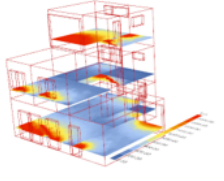
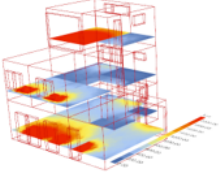
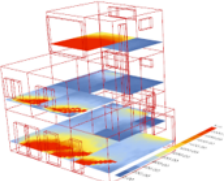
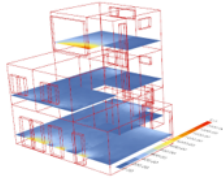
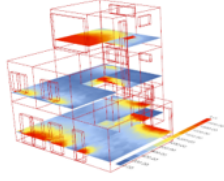
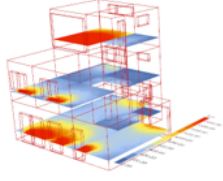
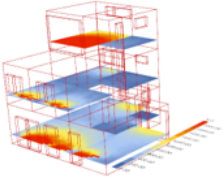
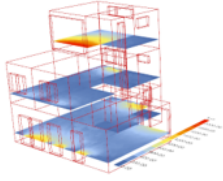
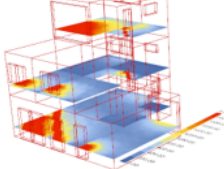
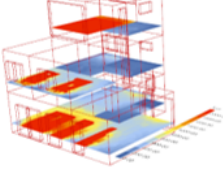
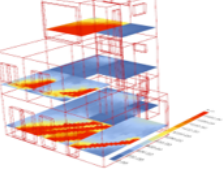
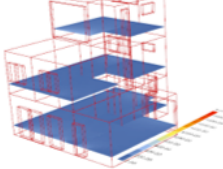
The spatial analysis identifies underused areas, particularly on the first and second floors, indicating the potential for redesigning these spaces to create more flow and usability within the house. Integrating SHT with sensors for tracking indoor climate and resident behavior can lead to a more interconnected and efficient living environment.

The indoor climate could be more optimal, especially when the second floor is too hot in the summer. The analysis suggests redesigning the south façade would significantly improve indoor climate conditions. The climate analysis using Ladybug Tools and EPW weather data for Hoogeveen indicates that the house's energy needs vary seasonally, with specific weeks identified as the coldest and hottest, informing the design interventions. The airflow analysis on the second floor highlights the importance of natural ventilation for thermal comfort, suggesting that openable windows or other ventilation strategies could be beneficial.

The house requires more heating than cooling or lighting, with specific areas, such as the guestroom on the second floor, needing significant cooling due to inadequate air circulation. Direct sun analysis reveals that the house receives considerable sunlight, particularly on the south and east façades and the rooftop, suggesting opportunities for solar energy use and the need for shading solutions.

The analysis suggests that the house could benefit from additional outdoor spaces and a reorganization of day and night areas to encourage more active use of the house throughout the day. The south façade is a critical area for redesign to manage sunlight exposure and improve the indoor climate, potentially through a kinetic façade system. Materials for the kinetic façade system must be carefully selected for their flexibility, lightweight, strength, and resistance to weather conditions. The design interventions should enhance the building's energy efficiency, focusing on heating needs and the potential for solar energy capture.

3.1.3 Design transformation based on analysis

This chapter expands on earlier analyses from the previous chapter and suggests transformation based on insights from those findings. In the previous chapter, the analysis delves into the house's spatial dynamics and climate responsiveness, setting the stage for integrated design enhancements. The house is characterized by a clear division between public and private spaces, with the latter occupying the upper floors. Despite the open-plan living area on the ground floor, the first floor's limited use and the second floor's seasonal abandonment due to heat issues suggest a need for spatial reconfiguration. The analysis underscores the potential for transforming the house into a SH, where interconnected spaces and responsive systems could significantly improve living conditions. By employing sensors to monitor indoor climate and resident movement, the design can foster an adaptive environment that is both energy-efficient and comfortable across day and night cycles.

Climate considerations are paramount, with the local conditions of Hoogeveen informing the design strategy. Utilizing Ladybug Tools, the analysis identifies critical seasonal weeks that influence the building's thermal and lighting requirements. The wind analysis simulations via Butterfly reveal the impact of surrounding structures on wind flow, which is crucial for natural ventilation strategies and suggests opening the windows and promoting the natural airflow within the building. The sun analysis highlights the abundance of sunlight on the south and east façades and the rooftop, suggesting the strategic placement of solar panels and shading devices. Meanwhile, the indoor airflow study on the second floor points to the benefits of introducing operable windows to mitigate excessive heat. Energy consumption patterns, analyzed using Honeybee Ladybug tools, reveal a higher demand for heating over cooling or lighting, with specific rooms like the second-floor guestroom requiring attention due to poor air circulation. The radiance analysis further informs the design by illustrating the heat distribution within the house at different times, suggesting the need for adjustable shading solutions. This chapter aims to develop design integration based on these analysis outcomes.

South façade and its impact on the indoor climate

The Ladybug Climate analysis showed the climate assessment based on the weather data. The conclusion from this analysis is that redesigning the south façade would have the most impact on the indoor climate of the house. (Figure 41) Different possibilities of this will be discussed.

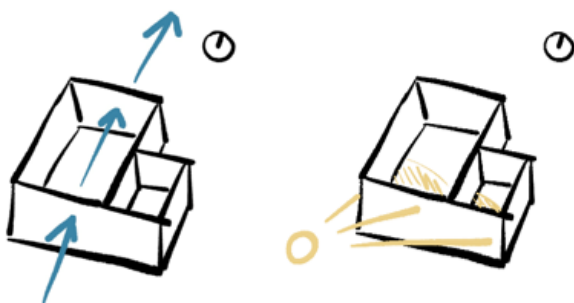

Figure 41: wind flow and sun on south façade, made by author.

The dominant wind flow is coming from the Southwest. This means that for the transformation, the south façade will make the biggest impact on the indoor climate throughout the year.

One of the reference projects in the literature review used an extra façade and adapted green for the well-being of the residents. (Figure 12) Also, more outside spaces are created by using a second façade. The same principles are used for transforming this house into a smart house. With the following step by step integration to the south façade, as shown in Figure 42, these principles will be added to the transformation:

- 1) Second façade for more shading and protection from the sun
- 2) Adding green to the façade
- 3) More shading possibilities for big windows
- 4) More outside spaces
- 5) Adaptation of green for the outside spaces

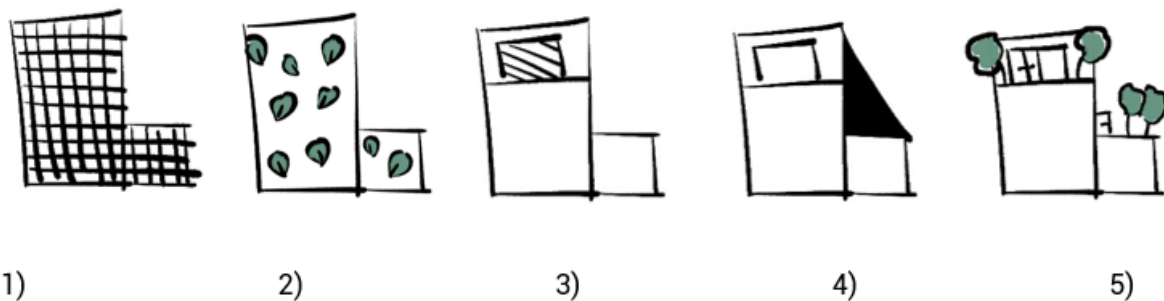

Figure 42: Step-by-step integration to the transformation, made by author.

A secondary façade, installed 30 cm apart from the existing southern façade, is a barrier for the newly added open areas on the first and second floors. This façade's design allows the façade to be incorporated with green elements, such as hanging pots, plants, or ivy, enhancing its aesthetic appeal. Additionally, this will serve as an extra cooling shield during hot days. Moreover, when the wind blows from the south and the windows are open, fresh air is enhanced by the greenery, improving the house's air quality. Plants absorb carbon dioxide and release oxygen, improving the air quality around the building. They can also filter out pollutants and fine particulates from the air. Figure 43 shows the basic structure of this second façade.

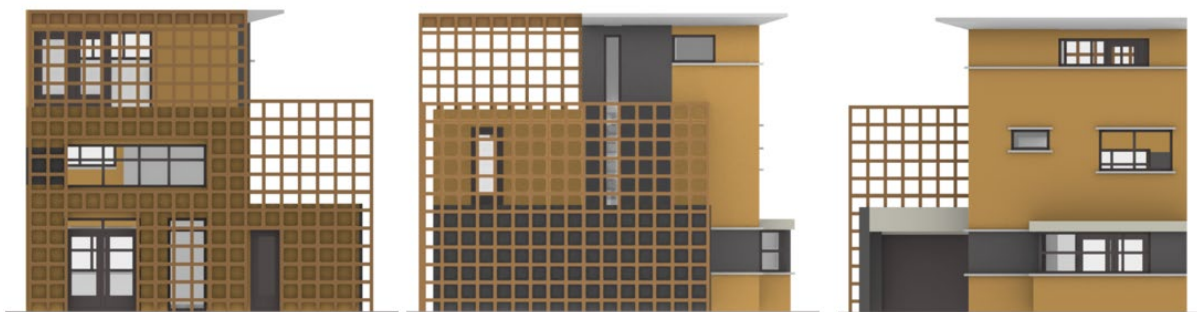

Figure 43: Basic structure for the second façade, made by author.

Integrations to the house

Figure 44 illustrates the transformative integrations. The ground floor retains its open space for optimal comfort. On the first floor, the windows will merge into a single large window, equipped with a kinetic shading system on the second floor that responds to sunlight and the house's heat maps. The first floor will feature expanded open spaces, including an outdoor area linked to the workspace and bedroom. On the second floor, another open space will be established, with doors and windows opposite each other to facilitate natural airflow throughout the house.

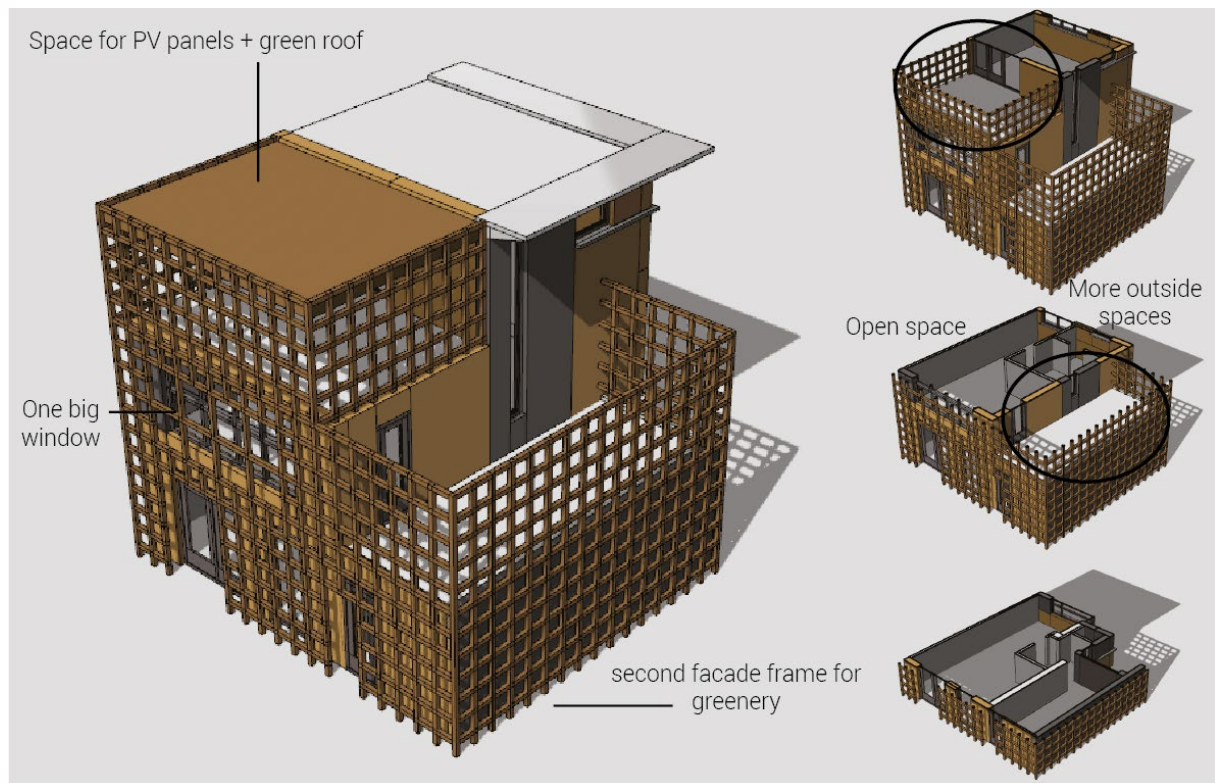

Figure 44: Transformation changes to the house, made by author.

Kinetic shading system

Incorporating a kinetic shading system into the house's design, particularly on the first floor, offers a dynamic and efficient solution to managing sunlight and heat. This system is responsive to the sun's position and the internal heat maps of the house. The kinetic shading system has adaptive sunlight control; it adjusts to the sun's angle in real time, ensuring optimal natural light while minimizing glare and excessive heat, especially during peak sunlight hours. By regulating the amount of sunlight entering the house, the system helps maintain a consistent internal temperature, reducing the reliance on artificial cooling systems and thus lowering energy consumption. The system's ability to adapt to changing sunlight conditions ensures a comfortable living environment throughout the day, preventing areas from becoming overly hot or bright. Residents can enjoy control over their environment, with the system integrating with SHTs for personalized settings based on individual preferences or activities. Table 11 offers different kinetic façades ideas for the south façade. The scripts of the different façades are shown in Appendix D.







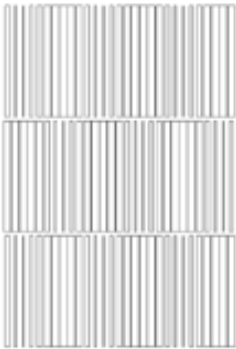

Description	Front view	Side	Perspective view
Façade experiment 1: rotation y-as			
Façade experiment 2: Kinetic façade system, based on sunlight			
Façade experiment 3: Kinetic façade system, based on sunlight			
Façade experiment 4: Kinetic façade system, based on sunlight			

Table 11: Kinetic façades ideas, made by author.

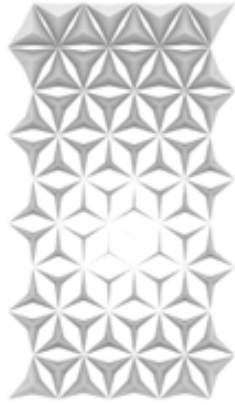
Kinetic shading system and effect on heatmaps

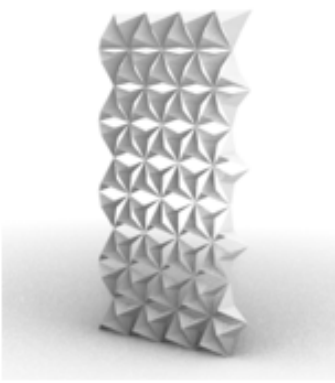
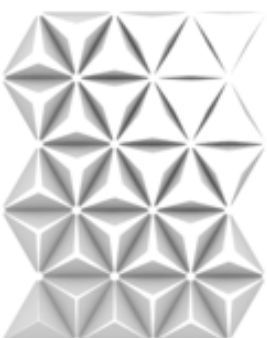
The primary function of a kinetic shading system is to regulate solar gain – the increase in temperature in a space, object, or structure due to solar radiation. The system can allow or block sunlight by adjusting its position according to the sun's angle, thereby controlling the amount of heat entering the building. Unlike static shading devices, a kinetic system can respond dynamically throughout the day and across different seasons. This means it can adapt to the sun's changing position, ensuring that it blocks excessive heat in summer (when the sun is high in the sky) and allows more warmth in winter (when the sun is lower).

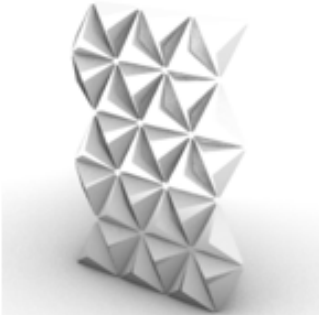
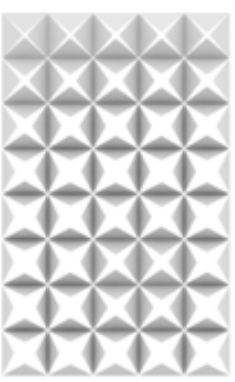
To assess the effectiveness of the façade system with the kinetic shading, experiment 4 from the previous chapter was conducted during the hottest week of the year, as indicated in the climate simulation. (Figure 33) The specific date chosen for this assessment was August 24, focusing on the critical times of 9:00, 12:00, 15:00, and 18:00. As illustrated in Figure 44, the shading system plays a crucial role in averting overheating within the space. It significantly lowers the lux levels at ground level.

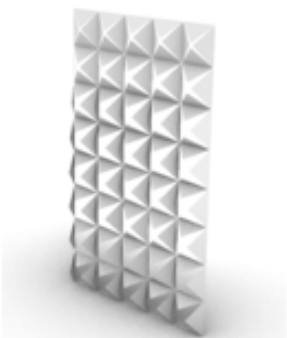
	Front view façade	Top view heatmap	Perspective heatmap
9.00			
12.00			
15.00			
18.00			

Table 12: Radiance simulation façade experiment 4, made by author.

Materialization of the shading system

According to Osama (2014), kinetic architecture plays an environmental role in sun shading and improving the functionality of the building. In kinetic architecture systems designed for sun-shading and interaction with light, selecting materials is crucial in ensuring optimal performance and durability. The materials used in such systems must exhibit specific characteristics to meet constant movement demands and exposure to environmental elements.

Critical Characteristics of materials in kinetic architecture system:

1. *Flexibility*: The materials must be flexible enough to allow smooth movement and adapt to different positions and configurations. This flexibility is essential for systems that must adjust to changes in sunlight and weather conditions.
2. *Lightweight*: The materials must be flexible enough to allow smooth movement and adapt to different positions and configurations. This flexibility is essential for systems that must adjust to changes in sunlight and weather conditions.
3. *High strength and density*: Despite being lightweight, the materials need high strength and density to withstand the stresses and strains of constant movement. This ensures the longevity and durability of the system, preventing wear and tear from impacting its performance.
4. *Resistance to weather conditions*: Given that these systems are often exposed to the outdoors, the materials must resist various weather conditions. This includes resistance to rust and corrosion, ensuring the system remains functional and maintains its aesthetic appeal over time.
5. *Integration with control systems*: The materials should be compatible with advanced control systems that operate through indirect control by multi-input. These systems utilize computer-driven ecological models, considering seasonal climates, daily sun paths, the building's programmatic use, and operating schedules to optimize the system's performance.

Table 13 shows the materials that suitable for these criteria.

	Characteristics	Applications
Aluminum	Lightweight, high strength, resistant to rust and corrosion.	Can be used for frames, panels, and other movable components.
Stainless steel	Durable, strong, and resistant to corrosion.	Suitable for structural components and joints, ensuring longevity and stability.
Titanium	Extremely strong, lightweight, and highly resistant to corrosion.	Ideal for structural components in harsh weather conditions.
Carbon fiber	Lightweight, very strong, and can be molded into complex shapes.	Perfect for movable panels and other components that require strength and flexibility.
ETFE (Ethylene Tetrafluoroethylene)	Lightweight, transparent, and resistant to pollution and UV rays.	Can be used for inflatable panels or cushions that adjust to control light and shade.

SMA (Shape Memory Alloys)	Materials that can return to their original shape after deformation when exposed to a certain stimulus, such as heat.	It is useful for components that need to change shape in response to environmental conditions.
Smart materials	Materials that change their properties in response to an electrical voltage allow for control over light and heat transmission.	Ideal for windows or panels that need to adjust their transparency to control sunlight.
Polycarbonate	Lightweight, durable, and resistant to impact and UV rays.	Suitable for panels and other components that require durability and UV resistance.
PTFE-Coated Fiberglass	Lightweight, flexible, and can be shaped into various forms.	Perfect for creating flexible shades or membranes that move to adjust light and shade.
Composite materials	Combining different materials to achieve desired properties, such as strength, flexibility, and lightweight.	Can be tailored for specific applications, providing a balance between strength, weight, and flexibility.

Table 13: materialization possibility for shading systems, made by author.

Hoogeveen, located in the Netherlands, experiences a temperate oceanic climate. Due to this climate, utilizing resilient materials for outdoor shading systems is imperative. Stainless steel is the optimal choice, offering resilience against varying weather conditions, including rain, wind, and occasional snow, while ensuring an effective sunshade. Its strength, low maintenance, and aesthetic appeal, combined with sustainability and longevity, make it a practical and cost-effective solution, aligning with eco-friendly practices and enhancing the building's architectural aesthetics. Stainless steel's compatibility with other materials further allows for adaptable design options, ensuring the shading system remains functional and visually appealing over time. Stainless steel can be used as the framework for the shading system, with PTFE as the core material. PTFE-Coated Fiberglass is highly adaptable to different weather scenarios. It's durable enough to withstand the rainy and windy conditions typical of Dutch weather while providing adequate sun protection during brighter days. This lightweight and flexible material makes it easy to install and maintain.

Visual Perspectives, details and Material Integration in Kinetic Shading Systems

Figure 45 displays the outside kinetic shading system in its entirely open configuration. The figure showcased the view from within the room towards the outside when the façade is entirely open.



Figure 45: Kinetic shading system in façade when opened, made by author.

Figure 46 shows the kinetic façade in action, adjusting to sunlight to prevent the interior from overheating. The figure provides the view from inside during this adjustment. This occurs when the sun shines from the west (after 15:00 on summer days). The façade continues allowing light into the building while monitoring indoor temperature to regulate temperature and light exposure effectively.

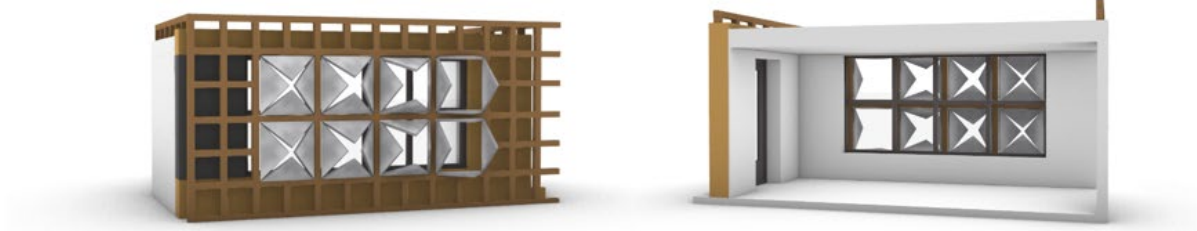

Figure 46: Kinetic shading system in façade reacting to the sun, made by author.

Two aluminum plates sandwich a layer of ETFE in between, and a rivet fastens them all together. This sandwich panel is then attached to an actuator connected to the wooden façade frame. Aluminum is chosen for its strength and lightweight properties, which are crucial for moving parts in the shading system and ensuring longevity with its corrosion resistance. The ETFE layer, sandwiched between aluminum plates, offers durability and flexibility. It's transparent and weather-resistant, making it suitable for outdoor applications while allowing light transmission.

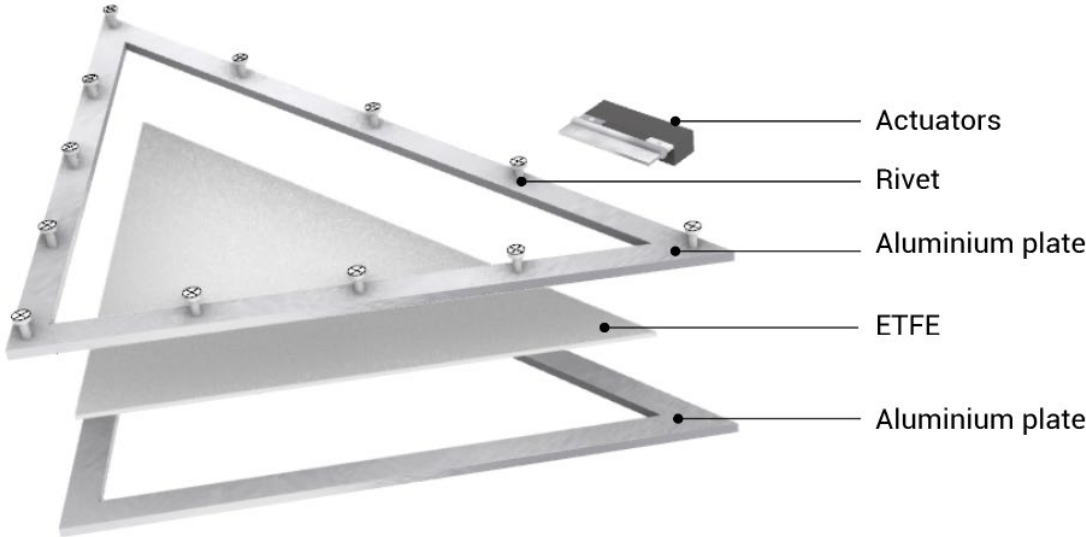

Figure 47: Detail shading panel, made by author.

The wooden façade frame complements these materials by adding natural insulation and aesthetic value. Wood, being less conductive to heat, helps maintain the temperature balance and its natural appearance integrates well with building exteriors, offering an eco-friendly and visually pleasing aspect to the design. Figure 48 illustrates how the sandwich panels are integrated into the wooden frame. The wooden façade uses coating to prevent corrosion when combining aluminum and wood.

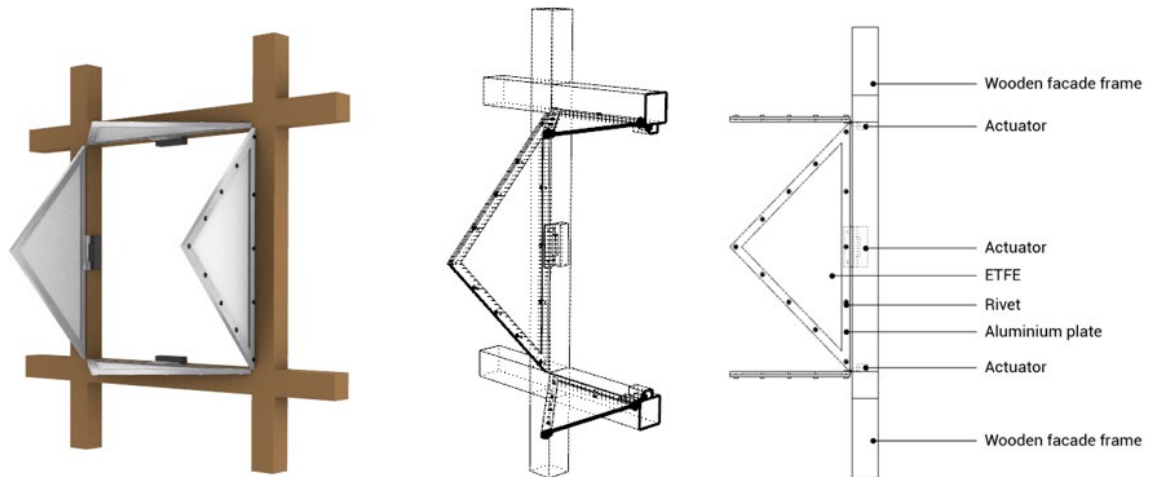

Figure 48: Shading panel integrated into the wooden façade, made by author.

3.1.3 Transformation shown in the layout

The upcoming sub-chapters explain the step-by-step process of transforming the house into a SH, concentrating on enhancing the resident's well-being. These sections will offer a comprehensive transformation layout and establish a link between the ideas presented in earlier chapters and their practical implementation in the final transformation. Additionally, these sections will delve into how SHTs and design principles are woven together, demonstrating their cooperative role in shaping a living space that is technologically advanced and comfortable, efficient, and nurturing for the resident's health and overall well-being. The alterations will be prominently displayed in the floorplans and cross-sections of the house, providing a detailed explanation of the transformations undertaken in each area of the house.

Enhancing Natural Ventilation on the First and Second Floors

The existing house's first and second floors lack open spaces supporting natural airflow. On the first floor, partition walls inhibit window airflow across the rooms. Meanwhile, the second floor has no operable window on the south façade. The proposed modification involves creating open areas on both floors to enhance indoor airflow. This includes strategically positioning windows directly across from each other to facilitate cross-ventilation. While the ground floor benefits from windows and doors arranged oppositely for air circulation, the second floor will significantly change. Here, two separate windows will be combined into a single, large window, providing the option to open it and thereby integrating the support for natural airflow into the design.



Figure 49: Opening the windows and doors to support cross ventilation through the building, made by author.

Integrating Spaces for Enhanced Air Quality, Light, and Energy Efficiency

By transforming the first floor into an open-concept area, the bedroom, guest room, and office are integrated into a single space. This approach reduces the need for numerous sensors and SHDs. The improved fresh air circulation enhances IAQ, contributing to a healthier and more comfortable living environment with optimal temperature regulation. Furthermore, the design maximizes natural light penetration, diminishing the reliance on artificial lighting and resulting in lower energy costs.



Figure 50: Open spaces support Smart Home Technology, made by author.

Maximizing Home Spaces: Integrating Terraces for Gardening and Enhanced Living

Incorporating additional outdoor areas on both the first and second floors benefits residents. Engaging with these spaces has proven to mitigate stress, elevate mood, and boost overall mental health. They present opportunities for landscaping and gardening, allowing residents to cultivate their lush retreats. By making these adjustments, the description maintains its original meaning, emphasizing the positive impact of green, flourishing outdoor spaces on mental well-being and highlighting the opportunity for residents to create a vibrant and thriving garden or green area. By adding terraces on both the first and second floors, the functionality and liveability of a house can be significantly enhanced. Typically, the upper levels of a home, like the second floor, are not utilized as much as the ground floor. This is often due to the ground floor's direct access to outdoor spaces like gardens or patios. However, by integrating terraces on the upper levels, residents gain additional, attractive outdoor areas that encourage them to spend more time on these floors.



Figure 51: Outside spaces, made by author.

Greening the Home: Wooden Façades with Planters and Kinetic Shading for Cooling and Well-being

The south-facing exterior and the accessible regions of both the first and second floors will be equipped with an additional wooden façade, offering the flexibility to hang planters and drape ivy leaves. This structure plays a crucial role in shading the dwelling, ensuring it remains cool during warmer periods and effectively mitigating the risk of overheating. Residents can tailor the green façade, selecting from various plants, blooms, or ivy, following their preferences and the changing seasons. Introducing a verdant, plant-laden area fosters a deeper bond with nature. A green, plant-filled space contributes to a stronger connection to nature, linked to improved mental health and well-being. An additional advantage of this green wall is that it directs fresh air into the home when the wind comes from the south, helping maintain a refreshing and revitalizing indoor atmosphere. A kinetic shading system is installed on the first floor to protect the house from excessive heat during hot summer days.

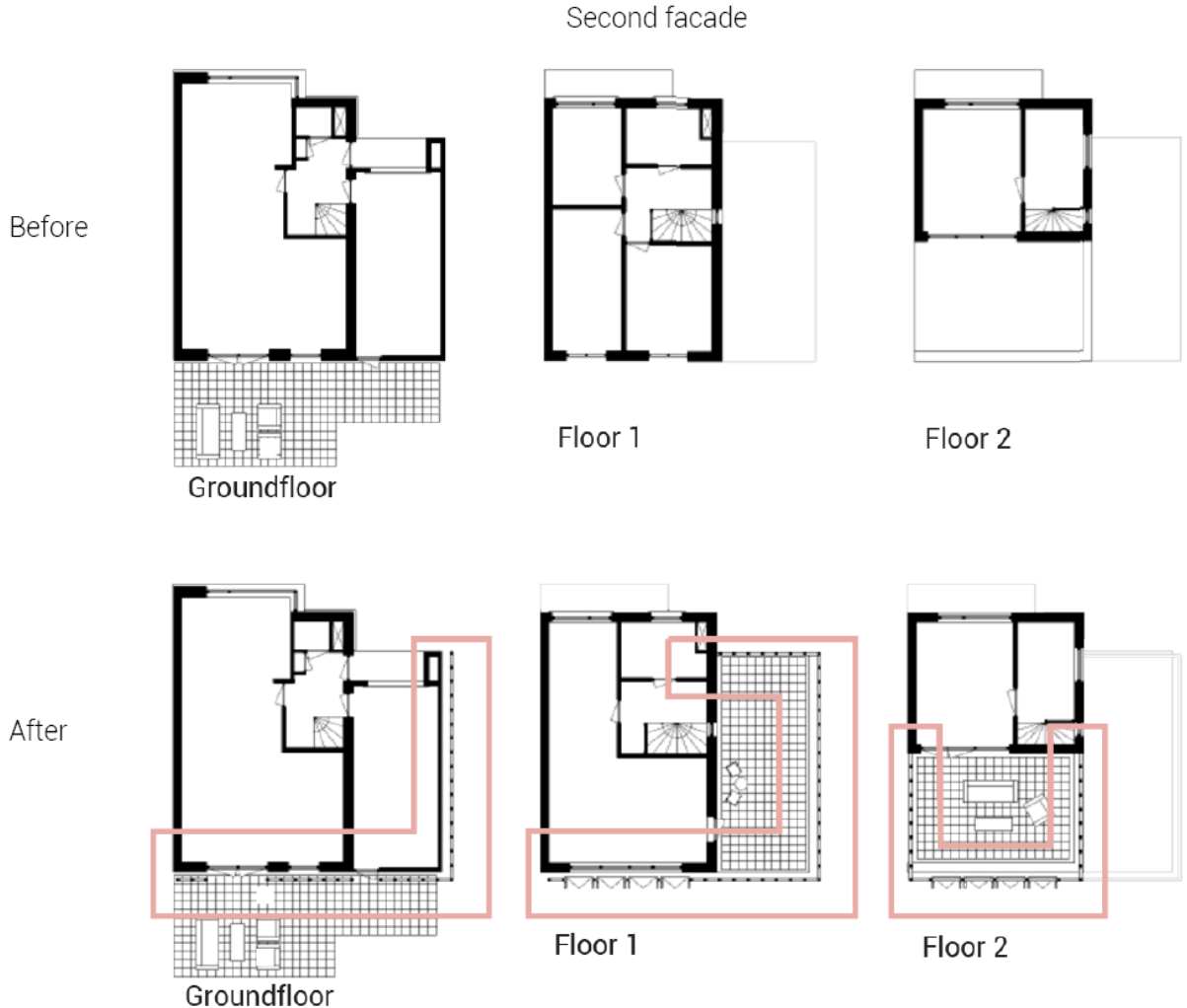

Figure 52: Second façade structure for adding green to the building and prevents building from overheating, made by author.

Optimizing Space: Redesigning the First and Second Floors for Functionality and Comfort

The functions assigned to the ground floor will remain unchanged. However, there will be alterations to the layout of the first floor as a house with a single resident doesn't have to have two guest rooms. The bedroom will be relocated to the cooler northern side of the home, while the workspace will be situated on the warmer southern side, adjoining the house's terrace. Up on the second floor, the existing guest room will serve a dual purpose: it will retain its capacity to accommodate guests. Still, it will also be utilized as an exercise area, providing a space for activities such as yoga or weightlifting. The adjacent outdoor area will complement this space.



Figure 53: Redesign of the functionalities of the spaces, made by author.

Smart Home Sensor Integration

The integration of sensors throughout the house is as follows: each room has temperature and humidity sensors, except for the hallway areas and the garage. Additionally, numerous motion sensors will be installed in various rooms and near the doors to monitor the resident's movement patterns. These motion sensors, connected to IoT devices, track the human occupancy schedules, and based on the system's setups, the IoT devices' settings adjust.

For instance, they could send emergency alerts to family members if the resident remains in one area for an unusually long time, such as two hours in the bathroom. Another possible application is a security feature where, if motion is detected while the resident is away, the IoT devices send an alert to the resident indicating potential intruders in the house. In addition to the previously mentioned sensors, light sensors will be installed on the second floor to monitor the ambient lighting levels, measuring the intensity in lux. This is a strategic move to prevent the space from becoming excessively warm, ensuring a comfortable and regulated indoor climate.

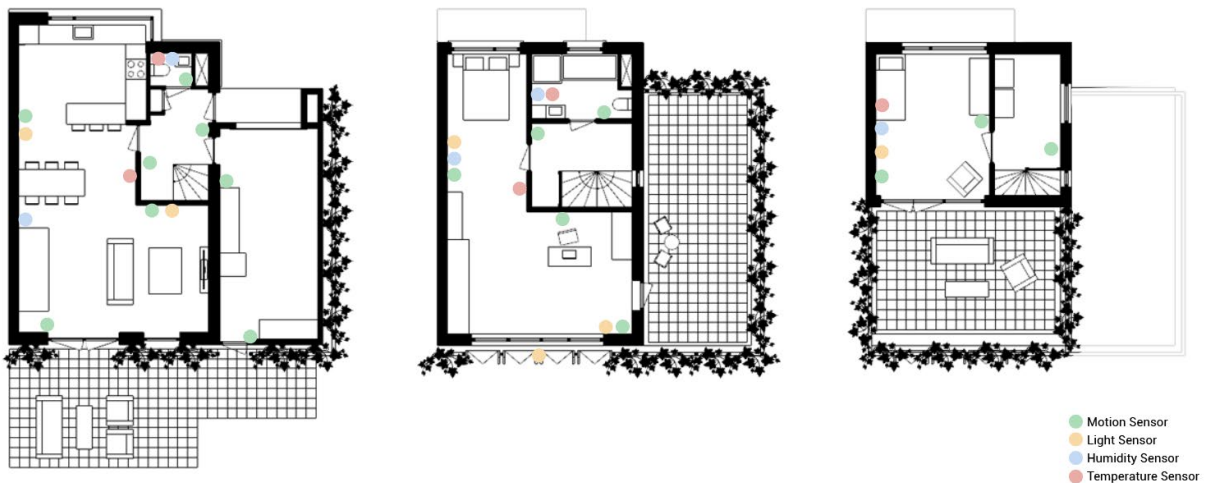

Figure 54 Sensor integration to the home, made by author.

Smart Home Devices integrations

Figure 55, Figure 56 and Figure 57 represents the integration of SHDs within the house, building on the discussion of sensors from the previous subchapter. These sensors play a crucial role in monitoring the resident's occupancy and controlling the various devices throughout the home. The house features window automation and indoor shading in the kitchen and living room, responding to temperature changes. Both the first and second floors have window automation for optimal cross-ventilation. The ventilation system activates to maintain air quality, while the floor heating is regulated by a smart thermostat. Security is enhanced with smart locks and motion sensors. Smoke detectors are strategically placed in all rooms except the bathroom and toilet, where the corridor's detector suffices. Air conditioning units on the south façade are reserved for extremely hot days, although their use is minimized due to the house's design. Additionally, the first floor features a kinetic shading system that reacts to sunlight and temperature variations. All these SHDs collaboratively ensure the indoor comfort and well-being of the residents, especially considering the needs of future elderly occupants to prevent overheating.

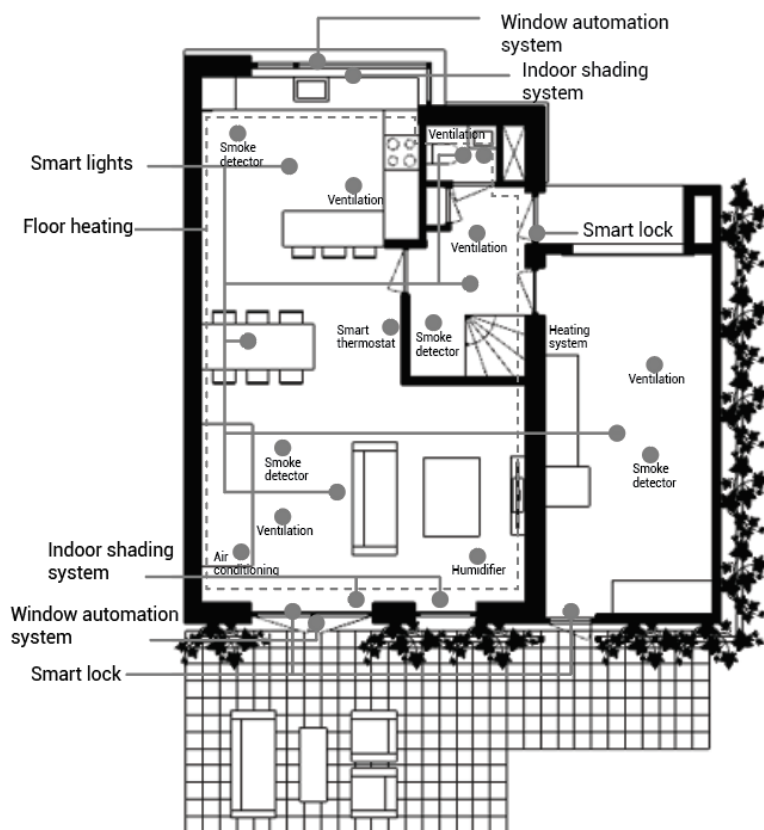

Figure 55: Integrations of the SHDs on the ground floor, made by author.

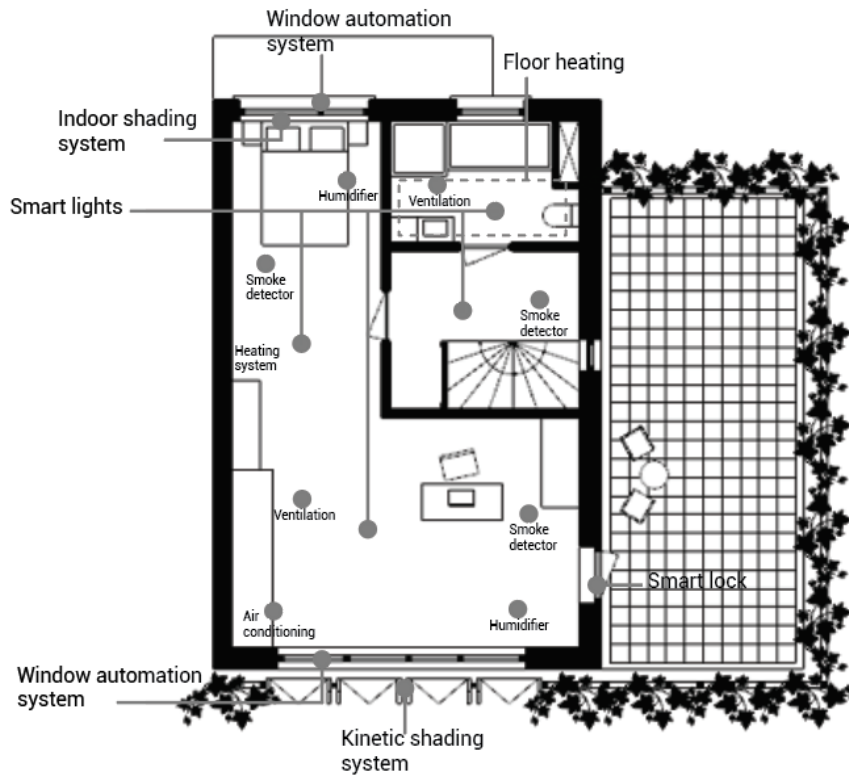

Figure 56: Integrations of the SHDs on the first floor, made by author.

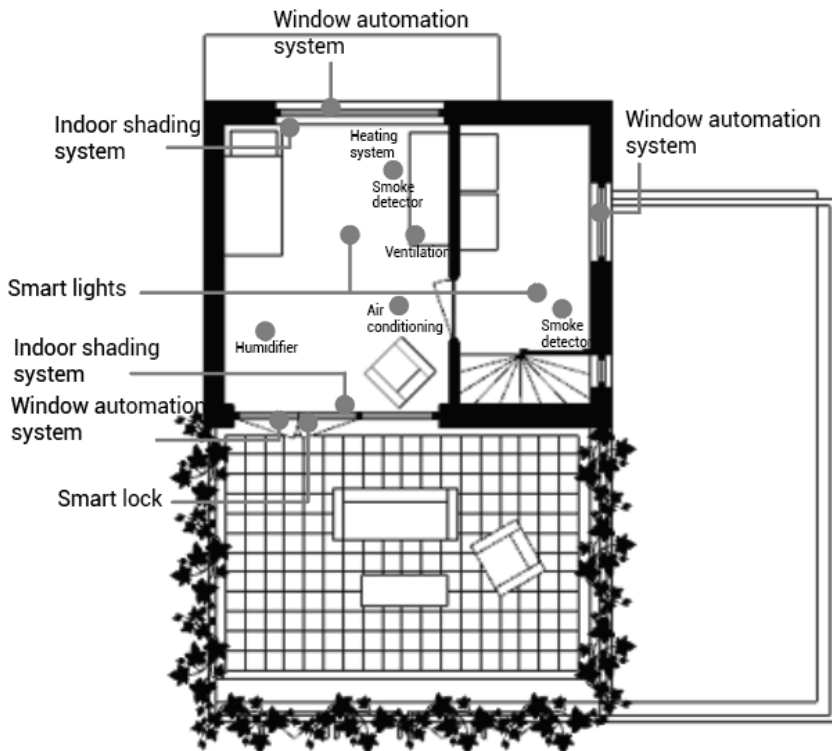

Figure 57: Integrations of the SHDs on the second floor, made by author.

Sustainable Living: Combining Green Roof and PV Panels for Eco-Friendly Energy Management

Adding green roofs and photovoltaic (PV) panels is a practical and eco-friendly choice. (Figure 58) Green roofs provide natural insulation, reducing heating and cooling costs, and help manage rainwater. PV panels use solar energy to generate electricity, cutting down on fossil fuel use and potentially lowering energy bills. Together, they reduce the home's carbon footprint and can be efficiently managed through SHT. They generate renewable energy, which can power smart devices and the mechanisms controlling a kinetic façade, making the system more sustainable and energy-efficient.

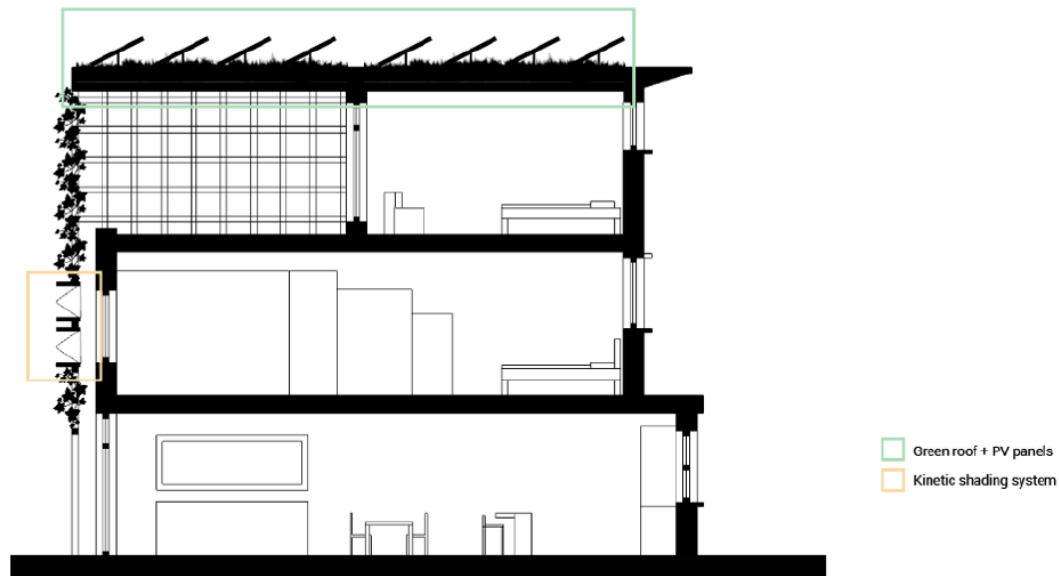

Figure 58: PV panels, green roof and kinetic shading system applied to the house, made by author.

Final transformation and rendering

The following renders showcase the changes the house experienced during the transformation; the integration of the sensors and devices is not visible here. Figure 59 illustrates the integration of the transformation on the South façade, highlighting the wooden structure and the potential for adding greenery, such as ivy leaves, to the façade. Figure 60 offers a more detailed view of this kinetic shading system. Figure 61 provides an interior perspective of the system. Figures 62 and 63 display the comprehensive SHS and its incorporation into the house, showcasing the roof equipped with PV panels and the two newly added terraces.



Figure 59: South façade, made by author.



Figure 60: South façade kinetic shading system, made by author.



Figure 61: View from inside the house facing the South, made by author.



Figure 62: Complete transformation North-East side, made by author.

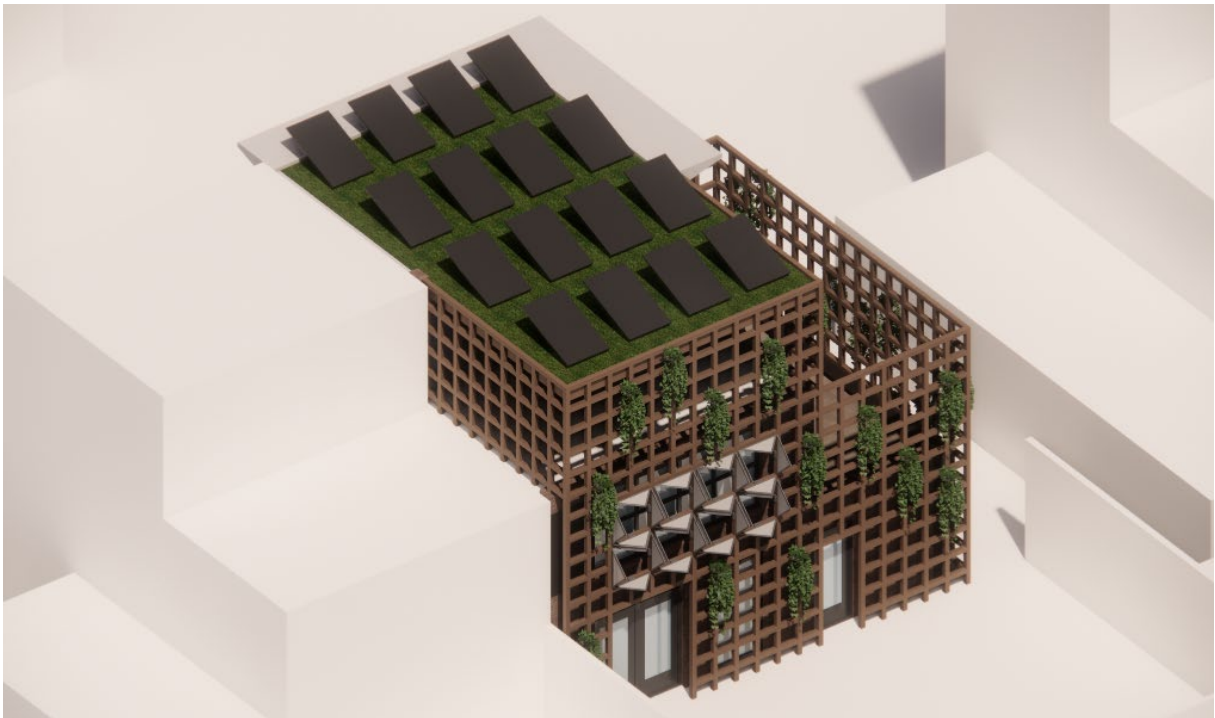

Figure 63: Complete transformation South-West side, made by author.

3.1.4 AI system integration to the Smart Home System

Based on the existing AI function from the literature review for this case study for transforming a house into a SH with the primary aim of ensuring the well-being of its residents, the most directly beneficial AI function would be Activity recognition. This function can detect a resident's actions and behaviors, such as if someone has had a fall, is sleeping, or is engaging in physical activity. This real-time understanding of a resident's activities can then be used to adapt the environment for safety, comfort, and health, making it a foundation for a well-being-focused SH.

The benefits of this regarding the transformation of the house are:

- **Optimized Space Utilization:** Understanding how spaces within homes are used can inform future architectural and design decisions. Spaces can be tailored more precisely to user behaviors, ensuring no wasted areas.
- **Enhanced Energy Efficiency:** Activity recognition allows for adaptive energy usage. If a room is often vacant at specific times, energy consumption can be reduced during those periods, aligning with sustainable building objectives.
- **Safety Design Improvements:** Recognizing frequent accident-prone activities can influence future designs. For instance, if falls frequently occur in certain areas, these zones can be redesigned with better ergonomics or safety features.

For this activity recognition, the following data will be used:

1. **Sensor data:** motion sensors to detect movement in specific areas of the home, temperature, and humidity sensors to monitor the environmental conditions, and contact sensors which detect if doors or windows are open or closed.
2. **External data:** weather data, whenever it is cold outside, and the system detects no activity in the home, it might predict that the resident is away and adjust the heating accordingly.
3. **Wearable devices:** like smartwatches, can provide information on heart rate, sleep patterns, and steps taken to understand the activity and the well-being conditions of the resident.

For a healthy indoor environment, the measures given from the literature study by Heinzerling et al. (2013) will be taken into consideration for the transformation:

- **Temperature (T) [°C]:** within the range of 18.5-24.5
- **Relative Humidity (RH) [%]:** between 43 and 67%

Based on these measures, the heating and ventilation system will be adjusted. However, considering the resident's preferences and needs is crucial to balance automated adjustments and personal comfort. It is important to note that the adaptability of the SHS plays a significant role in enhancing the resident's quality of life. AI-driven activity recognition optimizes the living space and learns and evolves based on the residents' habits and preferences.

To ensure the effectiveness of this system, it is vital to maintain a continuous feedback loop between the resident and the AI system. This can be facilitated through user interfaces that allow residents to provide input, make adjustments, and customize the system's settings to suit their needs better. Additionally, the system should be transparent, providing users with insights into how it operates and makes decisions, fostering trust, and enhancing user experience.

By integrating these principles, the SH can become an intelligent living space that ensures safety and efficiency and enhances its residents' well-being and comfort. This creates a living environment that is not just reactive to the residents' actions but is also proactive in anticipating their needs and adapting to their lifestyle, marking a significant step forward in the evolution of SHT. The diagram in Figure 64 provides a snapshot of the future SHS: a SH ecosystem driven by AI. It emphasizes Activity Recognition, fueled by diverse data sources, orchestrating a tailored living space. The continuous feedback loop and user interfaces ensure adaptability, marking a dynamic shift from reactive homes to proactive, intelligent dwellings.

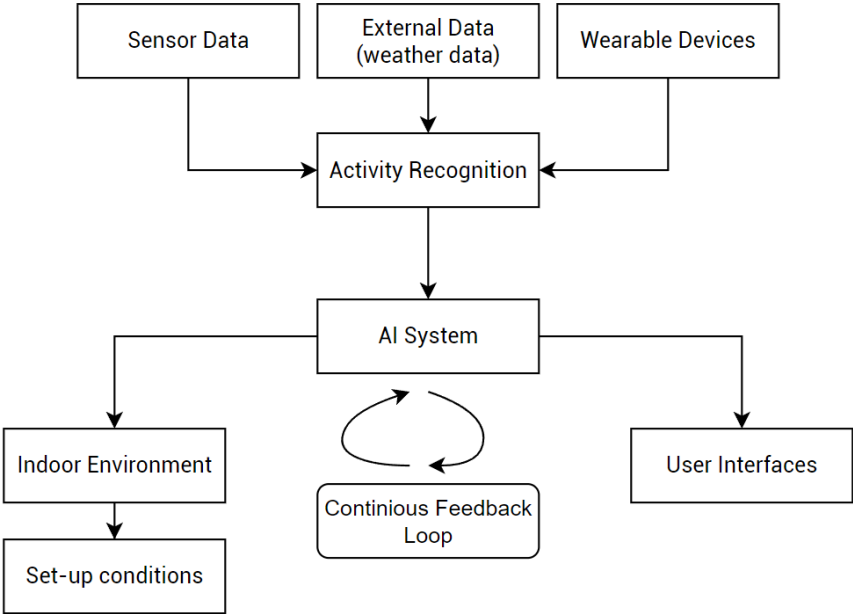

Figure 64: AI system of the Smart Home, made by author.

The user interfaces for the system could be designed as either a website or a mobile app for the resident's smartphone, serving as a communication bridge between the system and the resident. The smartphone app interface allows users to monitor SHDs in their residences, including their measurements. It also displays data from wearable devices, particularly the health metrics of the resident. The AI component of the app offers personalized suggestions based on the resident's habits, aiming to improve indoor climate, energy efficiency, resident movement, space utilization, nutrition, and security. Residents have the option to authorize the system to make certain decisions. Although this interface is illustrated in Figure 65, its development is beyond the scope of this thesis. It is a potential enhancement for the SHS and AI integration.



Figure 65: Home Assistance app, Smart Home app with AI suggestions for the resident, made by author.

3.1.5 Climate Analysis After Transformation

Heating, Cooling, and Lighting for Energy Use

The recent simulation focuses on the existing building, considering the transformative measures applied. This enhanced analysis reveals notable changes in the building's architectural and energy performance post-transformation. A significant outcome from the updated simulation is an increase in the monthly heating demand by 70kWh in January but a decrease of 110kWh in February. Looking at the Cooling and Heating energy on the graphs, there is an increase in Cooling Energy on the first floor but a reduction on the second floor. (Figure 66) This indicates that while the transformations have optimized certain aspects of the building's energy performance, there are areas that can benefit from further enhancements. Introducing a shading system on the second façade could effectively mitigate this increased cooling demand, ensuring a comfortable indoor environment throughout the year.

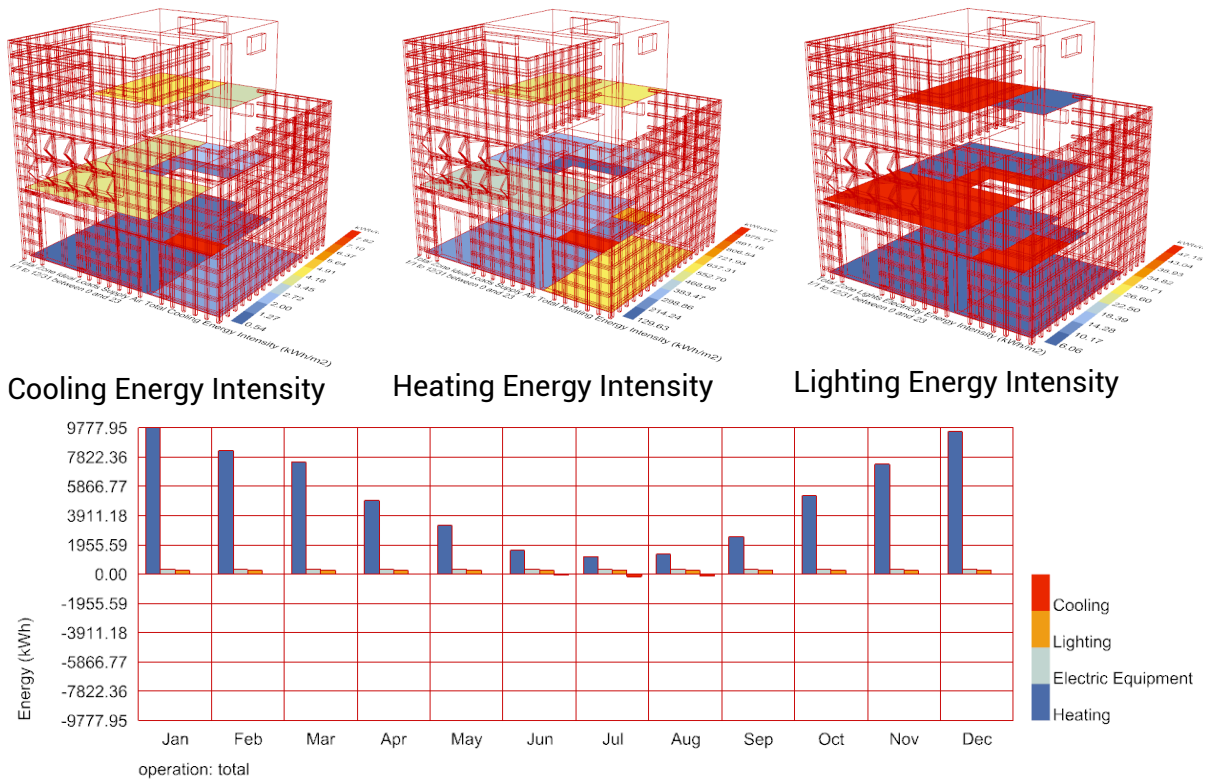

Figure 66: Honeybee energy analysis after transformation, made by author.

Modifying the rooms inside the house will yield the following results shown in Table 14. The changes will occur on the first floor, where three distinct rooms will be transformed into a single multifunctional space, serving as both a workspace and a bedroom. Opening the space will enhance airflow throughout the house, and SHDs can be minimized since they can monitor temperature, motion, and humidity in one room instead of three.

	Cooling [kWh/m ²]	Heating [kWh/m ²]	Lighting [kWh/m ²]
Ground floor			
Corridor	0.78	220.12	47.13
Toilet	1.02	658.16	6.06
Kitchen	0.75	292.08	6.07
Living room	0.61	246.90	6.06
Garage	1.65	537.52	47.15
Stairs	6.96	993.27	47.15
First floor			
Corridor	1.23	135.57	47.15
Bathroom	1.98	349.43	6.07
Bedroom	0.33	955.79	6.07
Working space	2.02	63.77	38.31
Second floor			
Corridor	3.65	483.43	47.15
Guestroom	3.10	498.03	6.07

Table 14: Energy loads per room after adjusting the program and opening spaces in the house, made by author.

The second modification involves opening windows on both the south and north façades, incorporating additional windows on the first floor, and installing doors that lead to outdoor spaces. (Table 15) Subsequently, more greenery will be introduced to not only cool the house and shield it from potential overheating during upcoming warm days but also to serve as a leisurely space for the resident, offering activities such as gardening.

	Cooling [kWh/m ²]	Heating [kWh/m ²]	Lighting [kWh/m ²]
Ground floor			
Corridor	0.83	219.19	47.13
Toilet	1.07	656.93	6.07
Kitchen	0.82	290.57	6.07
Living room	0.67	245.22	6.06
Garage	1.66	537.20	47.15
Stairs	7.59	989.32	47.15
First floor			
Corridor	1.33	134.87	47.15
Bathroom	2.21	348.16	6.07
Bedroom	0.62	956.30	6.07
Working space	7.51	63.60	38.31
Second floor			
Corridor	3.87	483.34	47.15
Guestroom	3.16	497.37	6.07

Table 15: Energy loads per room after opening the windows, made by author.

The subsequent simulation incorporates an additional façade to provide shading and prevent the building from overheating. A second façade can impact the cooling load of a house by providing additional shading, which minimizes direct sunlight and reduces solar gain, keeping interior spaces cooler. This additional layer can also function as a barrier to external heat, helping to maintain a stable indoor temperature and potentially reducing the reliance on cooling systems, thereby influencing the overall cooling load of the house. Furthermore, it may enhance the aesthetic and architectural appeal of the building while providing opportunities to incorporate green walls or other sustainable features that can further assist in regulating internal temperatures. However, the results indicate that this modification did not impact the building's energy consumption. Nonetheless, research indicates that shading can influence a building's energy needs due to the decrease in radiant energy absorbed and stored by its thermal mass. Nikoofard et al. (2011) clarify that other aspects, such as the objects' orientation, size, and distance in the shading, impact the heating and cooling energy requirements. Based on research, this transformation will still be applied to the house to improve indoor comfort, but the impact will be measured with a radiance analysis in the following sub-chapter.

Point in time-based analysis for radiance

This updated radiation simulation showcases the effects of transformational elements applied to the house, offering a comparative heatmap based on the sun's position at 9:00, 12:00, 15:00, and 18:00 hours. The selected dates remain consistent with the typical weeks in the previous climate simulation. On the second floor, the room that previously received the most sunlight now benefits from optimized shading solutions. The south façade, the primary recipient of sunlight, has been equipped with innovative shading mechanisms. These modifications ensure a balanced daylight experience and provide efficient cooling during the summer months. Given the increasing concerns of global warming and extreme heat days, these transformative measures are crucial in maintaining a comfortable indoor environment without compromising on natural light.

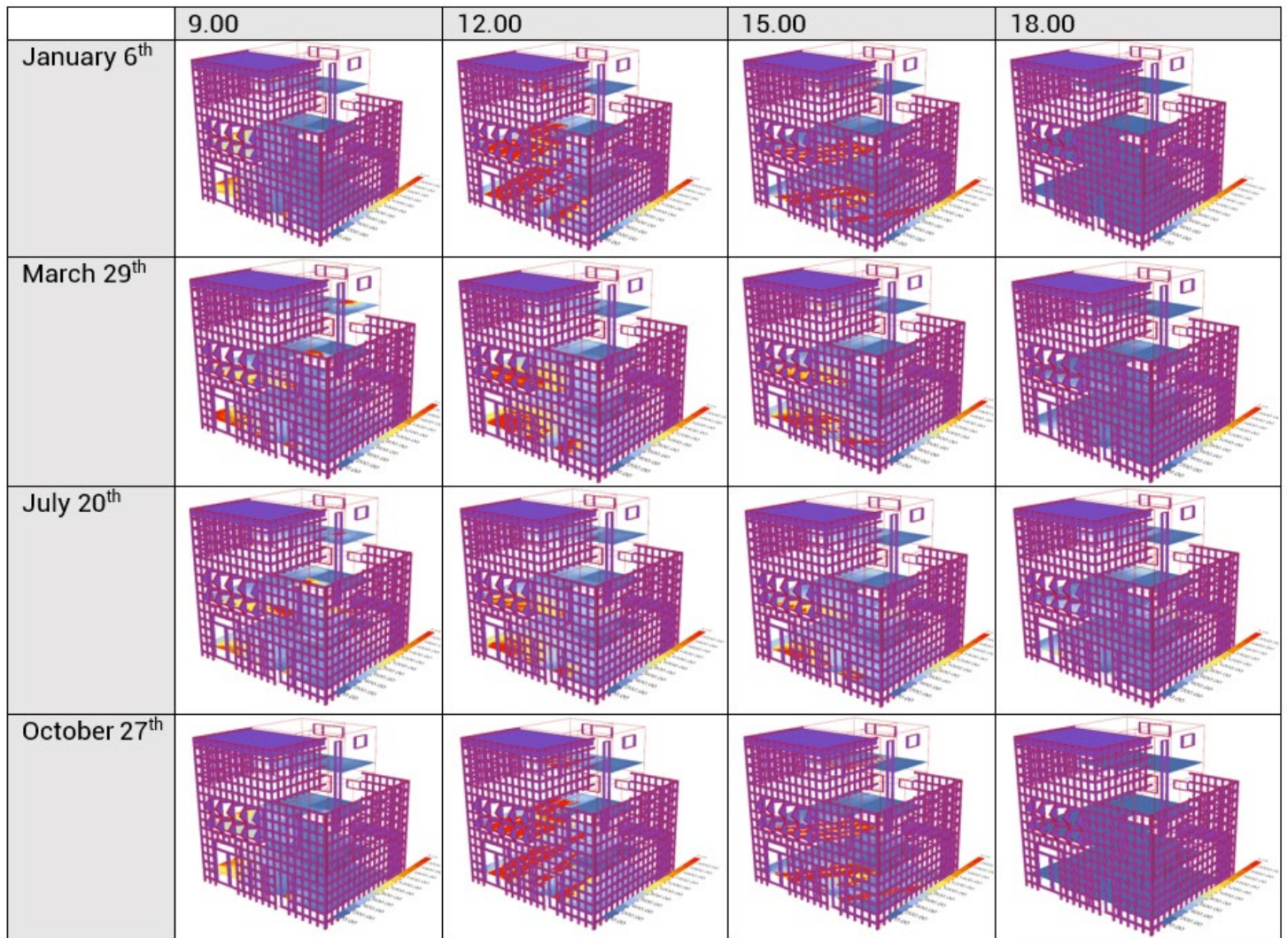

Table 16: Radiance analysis for the typical weeks of the year after transformation, made by author.

3.2.1 Integration of the AI-Driven Control Systems in Real-life and Simulated Building Environments

The real building refers to the actual physical model, where data is gathered from the building. The sensor measure devices give the information to the control system, which is coded and instructed to control the devices. This process can be seen as AI-driven, primarily when the control system uses data-driven decision-making methods. This process aligns with AI concepts: the real building and its sensors gather data from the physical environment. The data gathered by the sensors is processed and possibly transformed into a format that the control system can use. If the control system uses algorithms that learn from the data to make decisions (rather than just following pre-defined rules), then it employs AI. Based on the division made, the control system sends commands to devices to perform specific actions. If the system continuously collects data, adjusts its decision based on new data, and improves over time, it exhibits a characteristic behavior of the AI system: the ability to adapt and learn from new information. If the system can handle complex interactions by learning from them and adapting its behavior, it is another sign of AI capability. An AI system continuously evolves, adapts, and improves performance through data collection, processing, decision-making, actuation, feedback loop, and complex interactions, ensuring more accurate and efficient responses in real-world scenarios. EnergyPlus provides essential data to the EMS, enhancing its decision-making capabilities. The EMS (Energy Management System) interacts with digital models replicating real-world building scenarios in the simulation environment. Simultaneously, HomeAssistant functions as a control system, interfacing with the EMS. The communication between the EMS's output and input with this control system can be conceptualized as a 'Simulated AI Device.' This virtual setup allows for rigorous testing of various scenarios, developing innovative features, and fine-tuning energy-saving strategies without impacting actual buildings. This approach's primary advantage is its controlled environment, enabling developers to experiment with new algorithms, assess system responses under diverse conditions, and forecast the ramifications of modifications before actual implementation in real-world settings. (Figure 67)

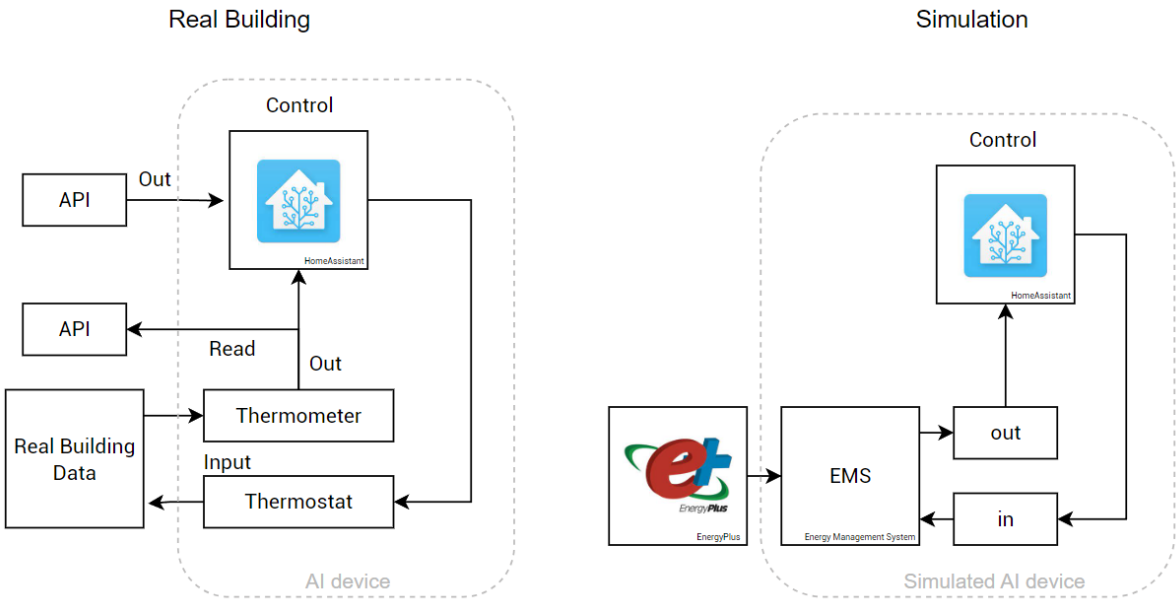

Figure 67: Difference between real building data and simulations of AI devices, made by author.

3.2.2 From Design to Reality: Simulating Smart Home Systems with Home Assistant and YAML Coding

After designing a SHS, the next step is to simulate the planned environment. This chapter explains how the SH design is turned into a simulation, highlighting the importance of coding and control systems, which is written in Appendix E. It's important to note that the coding discussed here is meant for real-world use, not just for simulation. Each SHD needs its code in the design. When these codes are added to Home Assistant, they show how these devices work together. Home Assistant is an open-source platform that lets users control all their SHDs from one place. It works with many devices and services and can automate tasks based on conditions like time or location.

The code for this SHS is shown in Appendix E and is written in YAML. YAML is a human-readable data serialization language commonly used to configure files and exchange between languages. In this context, the YAML code is used to create virtual devices. These virtual devices are essential for setting up various home automation. Users can simulate and control different aspects of a SH environment by programming these devices. The flexibility of this system is evident in the ability to replace these virtual devices with real-time devices simply by altering their entity ID. This makes the transition from a simulated environment to a real-world application seamless. Combining this automation with virtual devices allows for the creation of a comprehensive digital SHS. This system is based on a specific design that prioritizes efficiency, ease of use, and adaptability.

Home Assistant provides extensive resources on their website for users. They offer guidance on creating automation binary sensors, adding various devices to the network, setting temperature sensors, and creating smart locks. These instructions are likely detailed and user-friendly, catering to both beginners and advanced users to facilitate the integration of various SHTs into a cohesive system.

Some devices, like the heating and ventilation systems, need specific settings based on users' wants. For example, the temperature was set between 16 and 24 degrees, with a target of 21 degrees. These settings were added to the virtual devices. The ventilation system automatically keeps the indoor temperature at 21 degrees if it goes above 23 degrees. Temperature sensors check the indoor temperature from 16 to 30 degrees. Also, it's good to keep indoor humidity between 40-60%, as Juliana et al. (2021) mentioned.

With Home Assistant, users can set up scenes with SHDs. When making the prototype, the Raspberry Pi could be used to show parts of the SH design, like the kinetic shading façade system, which will be explored in the next chapter.

3.2.3 Prototype of the kinetic façade system

This prototype is inspired by the kinetic shading system outlined in the chapter 'Design transformation based on analysis'. It features a responsive system that adjusts based on the light intensity. The objective was to examine the temperature differences between the interior and exterior of the box, in order to assess the sun's impact and evaluate how the kinetic shading system can mitigate this effect to avoid overheating. Constructed from wooden plates, the prototype forms a closed box. (Figure 68) It incorporates a square shading mechanism consisting of four wooden triangles. Wood does not conduct well, which made it a suitable choice for the materialization of the prototype. The prototype has two LDR sensors and two temperature sensors. The temperature sensors are placed 10 cm apart inside the box and outside. Measurements were taken with these to compare the difference between the illuminated spots and the shaded areas. Each triangle has its servomotor, enabling precise angle control from 0 to 90 degrees in response to lux levels. The control script for this prototype is developed using a Raspberry Pi and programmed in Python, utilizing Thonny as the development environment. This prototype, set indoors, mimics an outdoor kinetic shading system. The study acknowledges that testing the prototype outdoors would be more effective. However, this was impracticable due to the Netherlands's rainy season. Figure 69 displays the setup of the prototype's mechanism. Appendix F provides more pictures of the prototype and explains the setting of the prototype related to the sun path.

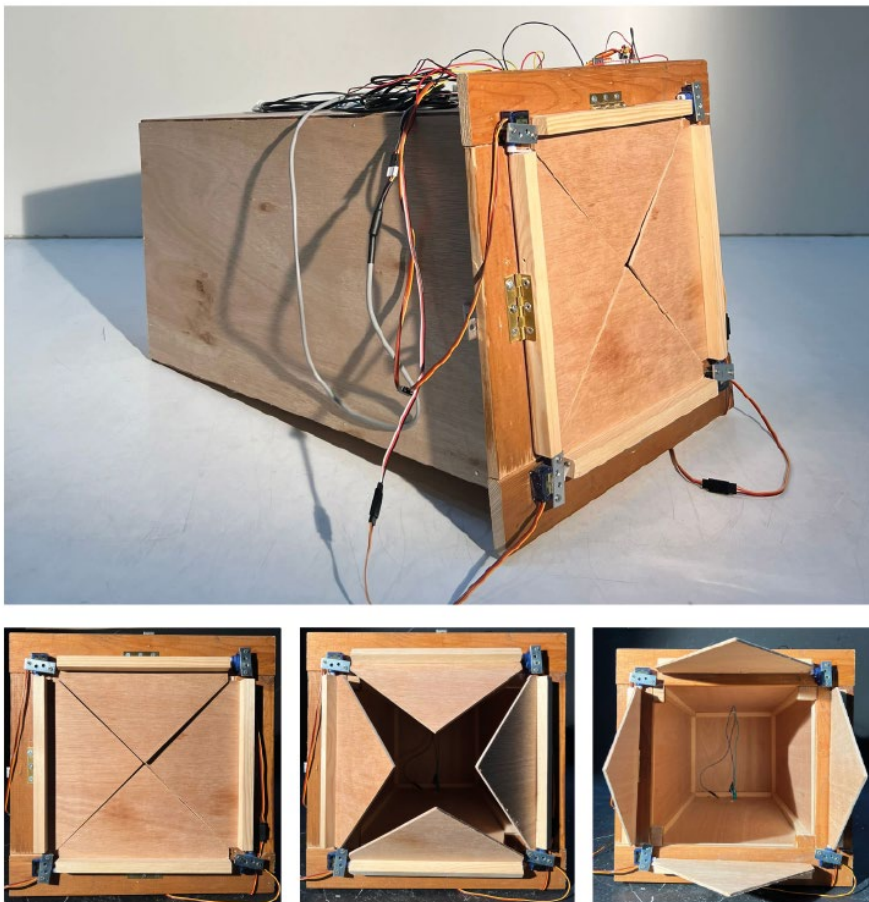

Figure 68: Kinetic shading system prototype, made by author.

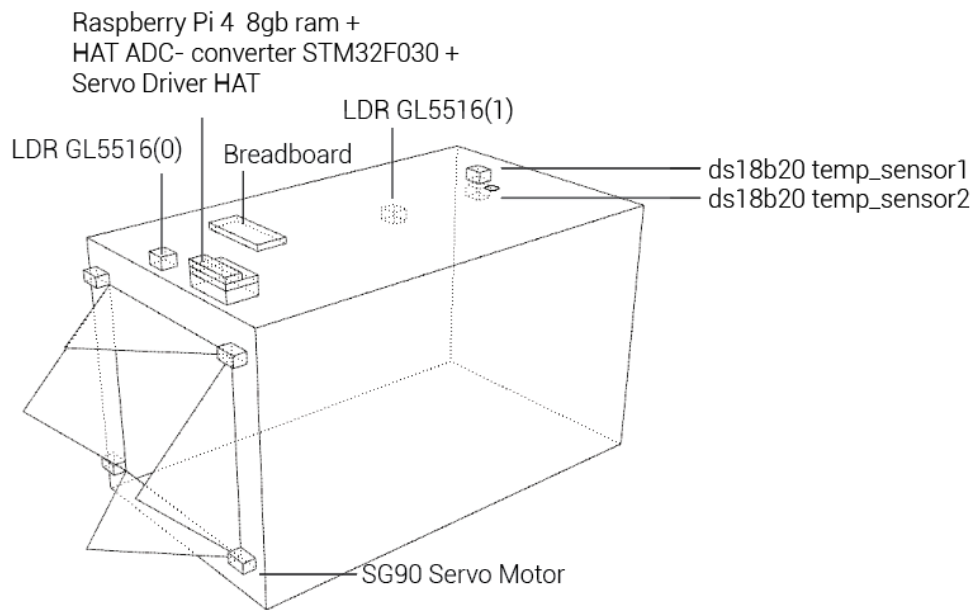

Figure 69: Mechanism set-up of the prototype, made by author.

The prototype carried out two distinct experiments using two separate codes. In the first experiment, the system's operation responds based on the readings from the LDR sensor placed outside the box. This allowed the shading system to adjust according to external light intensities. For the second experiment, the system's settings were governed by data from the LDR sensor inside the box, focusing on the internal light conditions. (Figure 70). During this experiment both sensors are measured to see the impact of the shading system to the temperature differences from outside and inside the box.

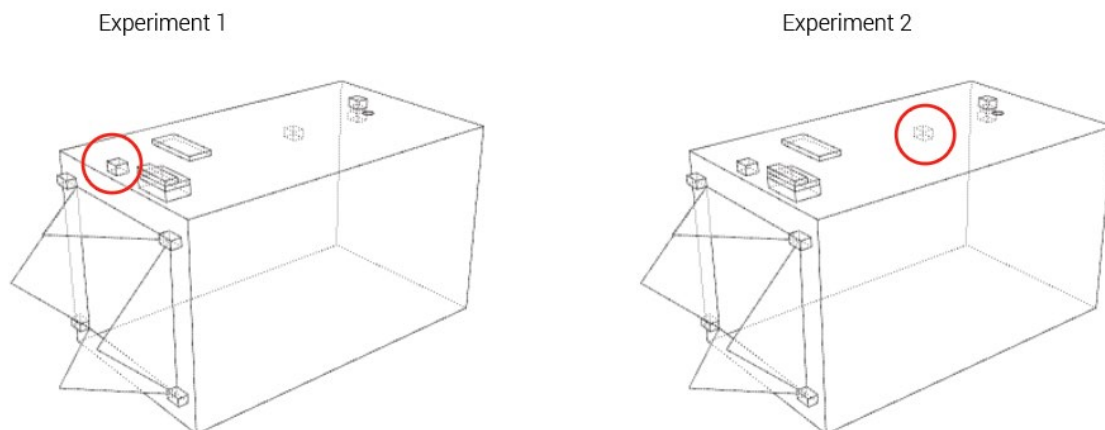

Figure 70: Experiment 1 and LDR outside the box, experiment 2 and LDR inside the box, made by author.

The first experiment closes the shading system when exposed to a light intensity of 4095 lux, which is the highest measurable value by the LDR sensor. Appendix G displays the code for this experiment. With this configuration, the triangular shades automatically adjust to a 45-degree angle when the external light level reaches 2048 lux. (Figure 71) This experiment aimed to analyze how different light intensities affect the internal temperature of the box. Recorded data occurred at 10-second intervals over five and a half days.

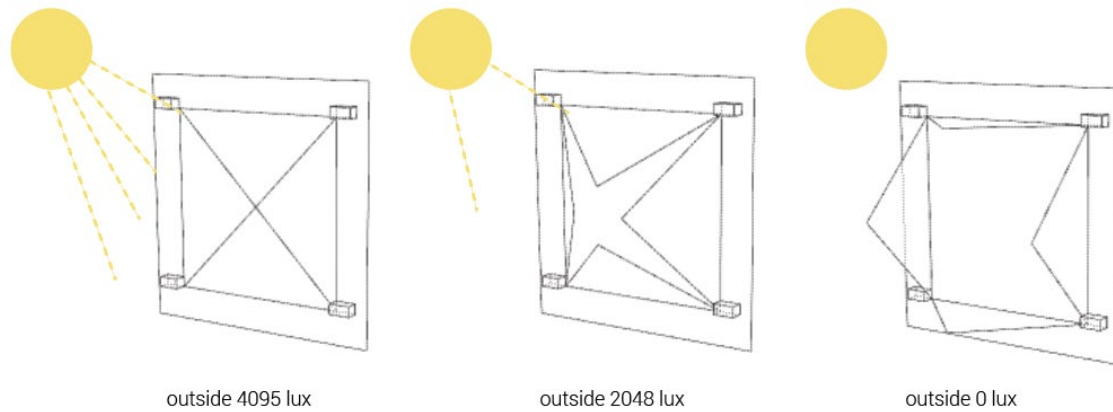

Figure 71 Respond system to the outside LDR sensor, made by author.

Results indicated that when the external light intensity exceeded 2300 lux, the temperature difference between the inside and outside of the box increased by approximately one degree. Figure 72 displays the graph of the data from the experiment: "inside light intensity" indicates the light intensity measurements from the LDR sensor inside the box. At the same time, "outside light intensity" refers to the readings from the LDR sensor outside the box. "outside temperature" measures the temperature outside the box, and "inside temperature" records the temperature inside it. A notable observation is the temperature difference inside and outside the box during the first three days. Several factors might contribute to this discrepancy, such as variations in airflow and convection around the box, localized microclimatic conditions, or even the influence of a Raspberry Pi near the temperature sensor, potentially causing the sensor to register higher temperatures due to the Pi's heat output. Nonetheless, the data consistently indicates a rise in temperature during daylight hours, correlating with increases in illuminance.

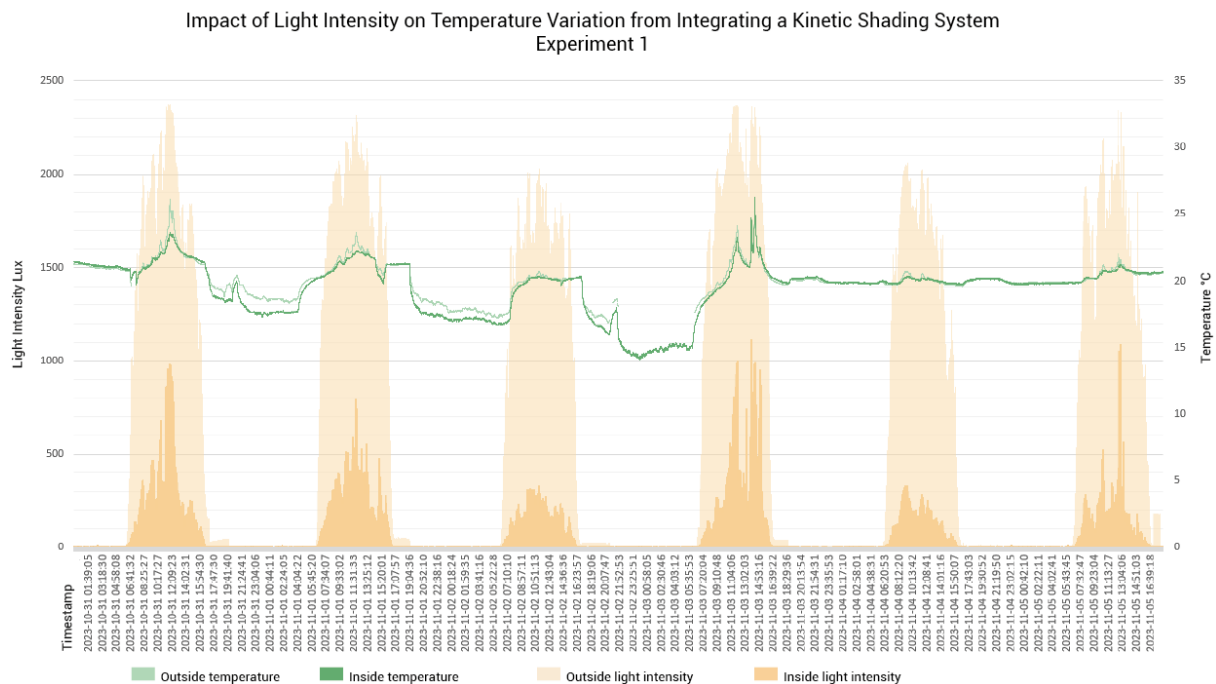

Figure 72: Outcomes of the simulation of the prototype experiment 1, made by author.

The set up of the second experiment is to maintain indoor light intensity at around 300 lux, regardless of the fluctuating outdoor light levels. Appendix H displays the script for this experiment. In this experiment, the LDR sensor is calibrated to measure higher light intensities. This setup aims to control the lighting inside the box to examine its impact on temperature differences and to evaluate the prototype's performance in this specific lighting condition. As the outside light intensity increases, the kinetic shading system will adjust to reduce light entry, maintaining the indoor light level at around 300 lux, as illustrated in Figure 73.

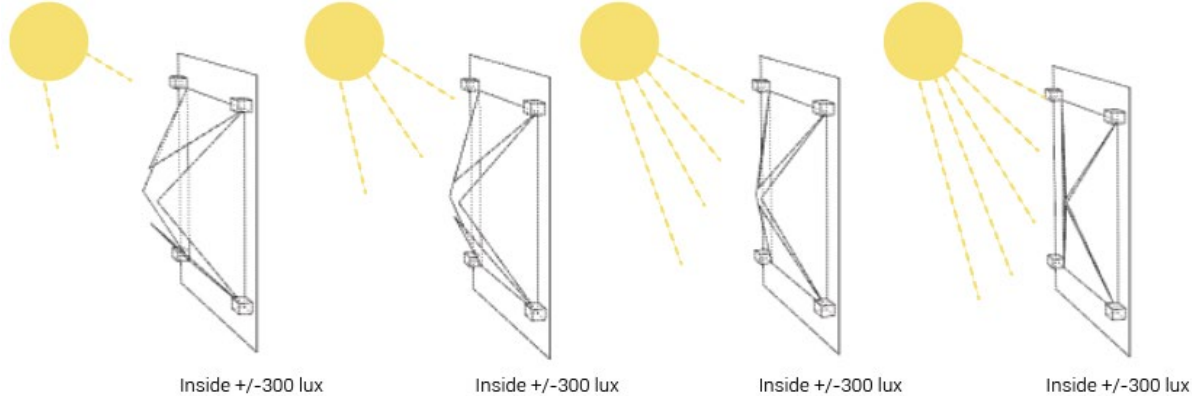

Figure 73: Respond system to the inside LDR sensor, made by author

The second experiment's outcomes demonstrated light intensity's effect on temperature. There was a higher light intensity during the five days when the prototype was operational than the preceding week. On the fourth day, the light intensity reached 6400 lux, leading to a temperature difference of nearly four degrees. At peak sunlight hours, the temperature varied by about four degrees. (Figure 74)

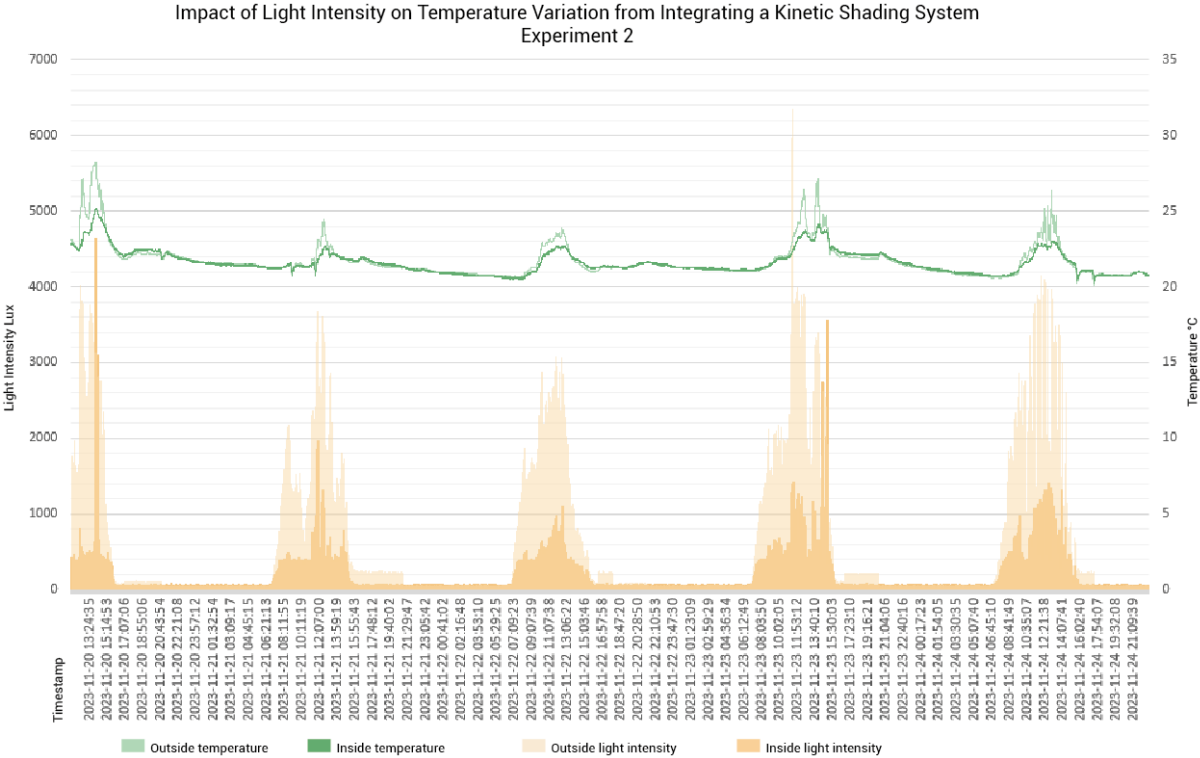

Figure 74: Outcomes of the simulation of the prototype experiment 2, made by author.

Compared to the first experiment, the indoor light intensity was lower in the second experiment, although there were occasional peaks, for example, on the fourth day. However, there is a discrepancy in the data from the fourth day. The plotted graph of a day shown in Figure 75 gives a better understanding of the data. The unexpected temperature and light intensity data might be due to a malfunction in the prototype's servo motors, possibly caused by a stuck triangular panel. This could significantly affect the system's ability to regulate light and temperature. Nevertheless, the system effectively adjusted to maintain the set point of around 300 lux. The influence was noticeable in the temperature readings; the inside temperature increased.

This experiment highlights that maintaining a specific lux level inside the control system presents a challenge due to the constantly changing outdoor light conditions. As the external light intensity varies, the system must continuously adjust and recalibrate the angles of its components to regulate the indoor light level effectively. Future research could incorporate an AI system to manage the dynamic control system for light intensity regulation. With its ability to learn from changing light patterns over time, AI can enhance the system's response efficiency. This application of machine learning would lead to more precise and effective adjustments, minimizing the need for frequent recalibration.

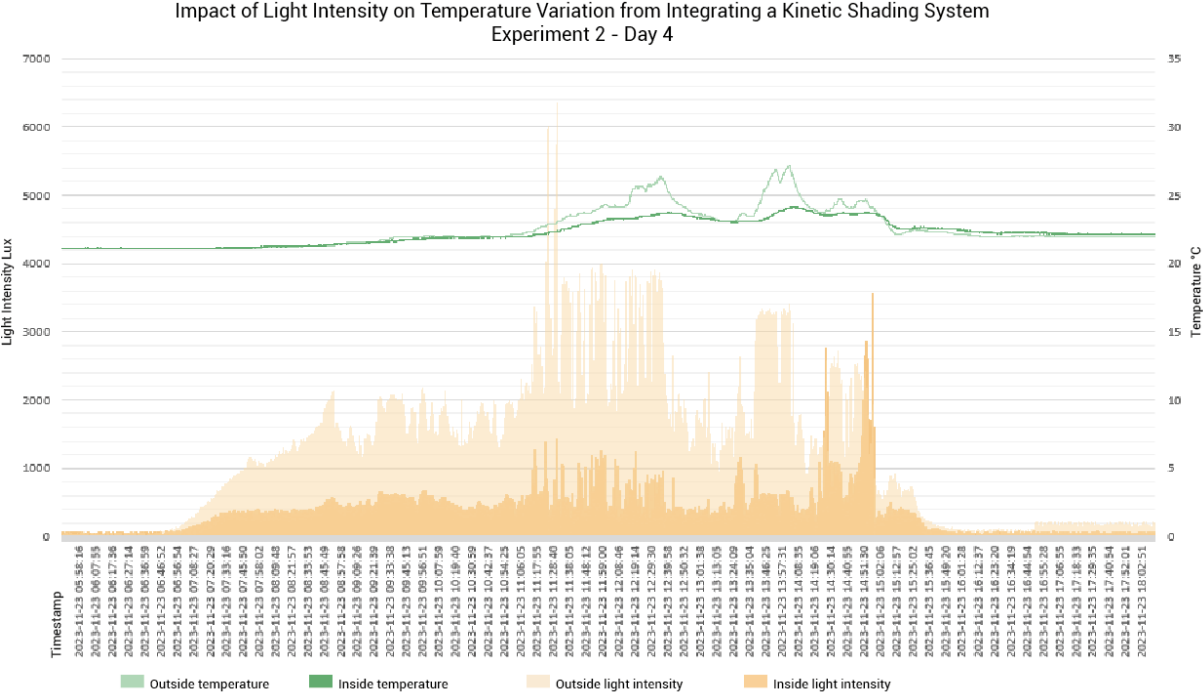

Figure 75: Outcomes of the simulation of the prototype experiment 2- Day 4, made by author.

In both experiments, researchers measured the room temperature where they placed the prototype. The second experiment underwent a second test period where an additional outdoor sensor was placed outside the room better to understand the relationship between outdoor and indoor temperatures. This implies using the code from the second experiment and adding an extra sensor to track the outdoor temperature. It included more measurements and an outdoor sensor to assess the impact of light intensity on indoor temperature, as shown in Figure 76. For a visual explanation of the prototype's setup, Appendix F provides pictures that detail the arrangement.

The testing period spanned five days, and concluding this experiment was challenging. While there is a correlation between sunlight and temperature increases, the variance between the inside temperature within the prototype and the outside temperature differed from other testing days. A potential influencing factor is the testing during the winter period, where inside temperature settings might have affected the results.

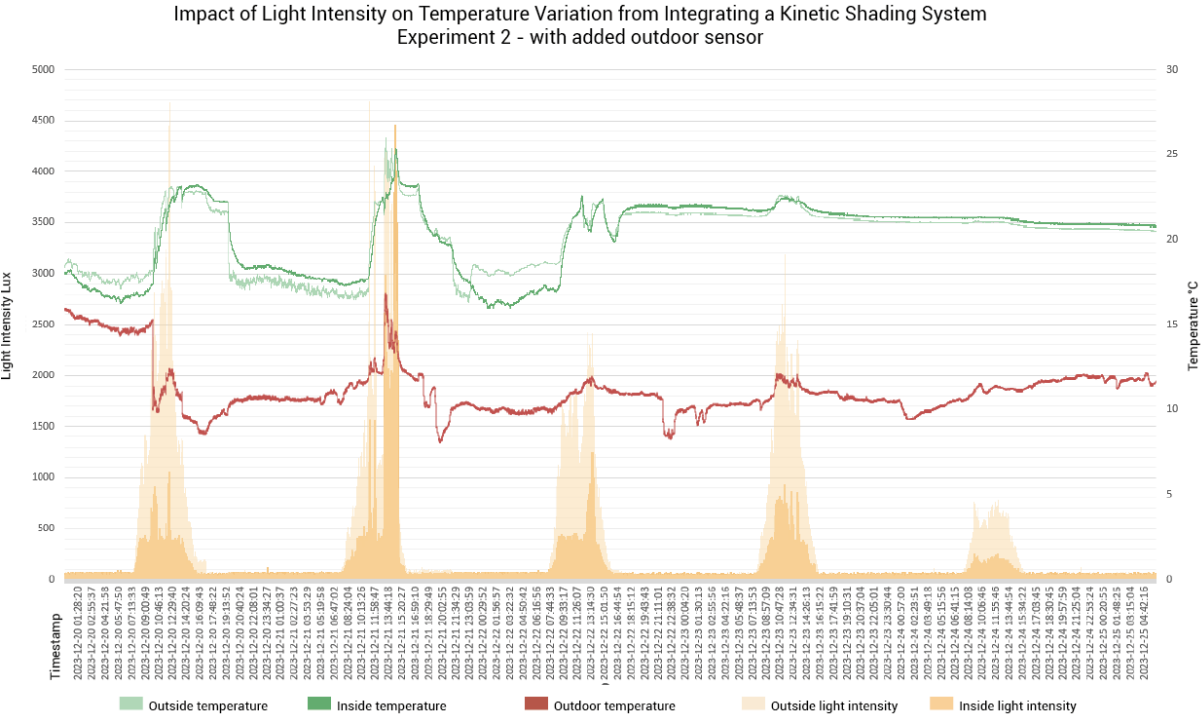

Figure 76: Outcomes of the simulation of the prototype experiment 2- with added outdoor sensor, made by author.

The experiments highlighted the prototype's ability to control light and temperature dynamically, though they also pointed out the need for mechanical reliability in practical applications. In conclusion, the kinetic façade system prototype marks a notable advancement in responsive architectural design. It can adjust to varying lux levels using a wooden, servo-motor-equipped shading mechanism, demonstrating material use and design innovation. It offers insights into the interplay between light intensity and temperature control. While the experiment faced limitations due to its indoor setting, it nonetheless provides a valuable foundation for understanding and improving kinetic façade systems in real-world outdoor environments. Considering environmental and technological factors, this prototype paves the way for future explorations in sustainable and adaptive building design.

3.3 Conclusion

The case study set in Hoogeveen, Netherlands, has been a journey of transforming a semi-detached house into a SH, primarily focusing on improving the well-being of a hypothetical 60-year-old resident. This transformation was guided by a thorough analysis of the existing structure, climate considerations, and the individual needs of the residents, leading to an innovative integration of SHTs and design modifications.

The house underwent significant changes, both internally and externally. Key modifications included enhancing natural ventilation on the first and second floors, integrating open spaces for improved air quality and energy efficiency, sheltering the building to prevent it from overheating, and adding terraces for gardening and enhanced living. Moreover, integrating wooden façades with planters and kinetic shading systems transformed the south-facing exterior into a green, energy-efficient shield against overheating. Adding green roofs and PV panels has been one of the design choices towards sustainable living. These features reduced the house's carbon footprint and collaborated with the SHS to create an eco-friendly, energy-efficient residence. Figure 77 illustrates that SHS that is developed from the transformation. The house is transformed into a SH with AI possibilities, which gives the resident the freedom to choose if it would like to apply automation changes of the AI or would like to set them up manually. The ability for residents to choose between automated AI-driven changes and manual setups provides a high level of personalization. This ensures that the technology adapts to the individual's lifestyle and preferences rather than forcing the user to adapt to the technology. By giving residents the option to manually control or automate various aspects of the home, it empowers them with more control. This can be particularly beneficial for the age group of 50-60 and elderly who may prefer to have hands-on involvement in their home management.

Transforming the house into a SH and adding design choices to the transformation that improved the quality of the house were beneficial improvements. This approach was more than just installing technology; it was about reshaping the home to improve the residents' quality of life. The redesign involved integrating smart technologies and modifying the house to suit these new additions better. However, it is debatable that transforming a house into a SH would mean adding technological devices, which would already complete the transformation. Yet, for the optimal improvement of indoor comfort, the transformation done to the house added meaning to the complete SHS.

A crucial aspect of this transformation related to the technological aspect of the SH is the integration of SH sensors and devices. These innovations improved security and comfort and addressed the residents' health and well-being needs. Each element created a more responsive and adaptive living environment, from temperature and humidity sensors to smart locks and motion detectors. Central to this transformation was the focus on the resident's requirements. By tailoring the SH solutions to fit his lifestyle and health needs, the house becomes a more comfortable and convenient space and a supportive environment for aging in place.

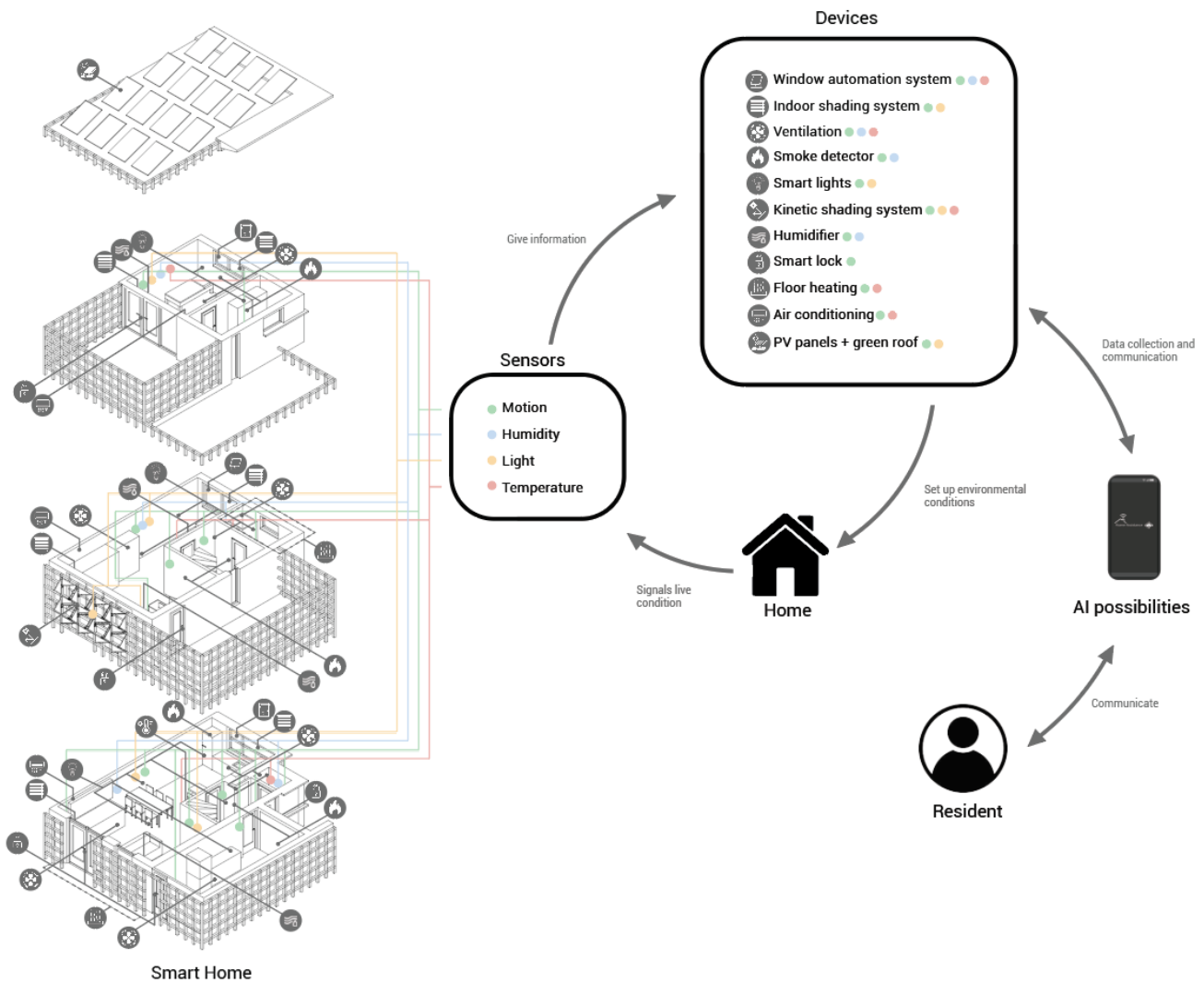

Figure 77: Smart Home System, after transformation, made by author.

The transformed SH could lead to it being classified as an intelligent house. The current system operates as a SH, learning from resident interactions and suggesting environmental alterations for the user to approve or deny. This design prevents it from becoming a fully automated system that makes changes without user permission. By giving the residents the choice to accept or decline these suggestions, the system empowers them, aligning with the smart home concept rather than an intelligent home, which would function without requiring human input. The difference between the SH and intelligent home lies in how the system uses data—whether trained on historical data from previous residents, general data, or learning from ongoing interactions with the current user. This approach suggests that the SH has the potential to gradually transform into an intelligent home as it adapts over time. In the initial phase, generic assessments for healthy house measurements would establish a baseline for the indoor environmental condition. The usage of the interface allows the intelligent systems to learn from the feedback loop by tracking the number of days and their feedback on environmental conditions and suggesting their preferences by learning the pattern of the user over time instead of applying the same thing based on the measures. Eventually, the system

would transition to incorporating the residents' preferences. While this transformation represents a smart design, these elements are essential for achieving an intelligent system.

The prototype resulting from the transformation design illustrates the distinct meaning of 'smart' and 'intelligent.' The definitions of 'smart' and 'intelligent' differ in context, with 'smart' often referring to the interconnectedness of devices and 'intelligence' relating to the capacity for responsiveness. Although the prototype device exhibits responsiveness, it cannot be classified as intelligent, as it lacks AI integration in its Python programming. In the literature review, 'smart' and 'intelligent' were distinguished, with 'smart' described as more adaptive and 'intelligent' as more responsive. In the context of this SHS, the integration of the interface enables the SH to function as an intelligent home. Considering the overall system, this device could contribute to an intelligent home environment. However, this device defines itself as a smart device rather than an intelligent one.

In conclusion, this case study exemplifies the positive impact of thoughtfully integrating SHT and sustainable design principles. It demonstrates how a traditional living space can be transformed into a smart (and optional intelligent), comfortable, and environmentally responsible home, ready to meet the challenges of the future and improve its resident's well-being. This case study serves as a model for similar transformations in residential spaces. The lessons learned and the guidelines developed provide valuable insights for architects, designers, and homeowners looking to integrate smart technologies and sustainable practices in their homes. The transformation highlights the potential of SHs to enhance the quality of life, particularly for residents with specific health and well-being needs, by looking at the indoor comfort of its house. However, as people's needs evolve, transforming an existing house becomes necessary. This evolution means that user requirements change over time, necessitating adaptable solutions. Therefore, a different, more flexible approach that accommodates varying situations and the evolving needs of different users is essential. This concept of adaptability and flexibility in design is a valuable area to explore for future developments.

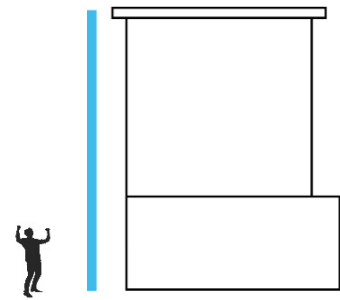

IV DISCUSSION, CONCLUSION AND REFLECTION

4.1 Discussion

SHT is increasingly becoming a part of everyday life, particularly in developed countries. This research contributes to the conversation on how technology can improve living standards, especially for aging populations. The focus on elderly needs and the potential of SHs to enhance their quality of life positions the research within a significant social context. Within the academic community, this research adds to the ongoing discussion about the role of technology in our lives. It bridges the gap between technological advancement and practical, user-friendly applications. Addressing concerns like cybersecurity and accessibility also contributes to a more balanced view of technological progress.

Smart devices have shown the potential to learn from residents' behaviors and make predictive adjustments. However, the extent to which these devices genuinely understand and cater to the nuanced needs of residents remains a subject of ongoing research and development. The effectiveness of these devices is not uniform, and there is a noticeable gap between their potential and their actual performance in real-world settings. Integrating smart devices in homes inevitably leads to collecting vast amounts of personal data, raising serious privacy and security concerns. Robust security measures and transparent data practices are essential. Building trust with residents is paramount, and there is a need for industry-wide standards to safeguard user data and ensure responsible use.

The nature of SHs involves collecting, processing, and storing vast amounts of personal data. This data is crucial for the functionality of smart devices, enabling them to learn from residents' behaviors and make predictive adjustments to enhance comfort and efficiency. However, this raises significant concerns regarding data privacy. Residents' intimate details, daily routines, and personal preferences are captured and stored, potentially making them vulnerable to data breaches and unauthorized access. Ensuring robust security measures and transparent data practices is paramount. There is a pressing need for industry-wide standards and regulations that safeguard user data, ensuring that residents have control over their information and understand how it is being used.

The implementation of AI within SHs demands careful ethical consideration. How AI systems make decisions can be unclear, resulting in a potential deficit in transparency and accountability. Prioritizing ethical considerations in the design and application of AI is crucial, with a focus on fairness, transparency, and accountability. It's essential to develop thorough guidelines and frameworks to govern the ethical use of AI in residential settings, aiming to prevent unintended harm or bias and guaranteeing the responsible deployment of this technology.

The research's focus on transforming existing houses into SHs directly impacts architectural and interior design. It challenges designers to think beyond traditional construction and consider how integrated technology can enhance living spaces. This perspective could lead to a paradigm shift in how homes are designed, constructed, and interacted. As discussed in the research, the progression from smart to intelligent homes indicates a future where technology is not just a tool but an active participant in our daily lives. This trajectory raises questions about dependency, privacy, and the nature of human interaction with technology. The research contributes to an essential debate about the future being shaped by AI and IoT.

4.2 Conclusion

Main question: *“How can a house be transformed into a smart house to improve the well-being of its residents using smart devices and the help of artificial intelligence?”*

Transforming a house into a SH to enhance the well-being of its residents involves a comprehensive approach, starting with a deep understanding of the users' future needs. This understanding guides the selection and implementation of smart technologies tailored to those requirements. The transformation process also includes a thorough assessment of the house itself, considering its unique environmental conditions and potential for integration with smart systems. In each room, careful consideration is given to the placement and type of sensors needed to monitor and respond to the residents' behaviors effectively. These sensors form the foundation for future predictions and automated adjustments in the home. For instance, in living areas, sensors might focus on optimizing lighting and temperature for comfort, while in bedrooms, they could monitor sleep patterns to promote better rest.

The integration of smart devices is a critical part of this process. This includes devices like smart thermostats, lights, locks, and appliances that can be remotely controlled and automated to improve efficiency and convenience. Artificial Intelligence (AI) plays an important role here, analyzing data from these devices to learn residents' habits and preferences. Over time, the AI can automate tasks in a way that seamlessly aligns with the residents' daily routines and lifestyle changes, making the home more intuitive and responsive to their needs.

Health and well-being are crucial factors in the transformation of the house, with SHs equipped to monitor various health-related metrics. Environmental sensors ensure optimal air quality, while wearables and other health-monitoring devices integrate with the home system to keep track of fitness and wellness data. Remote control capabilities and automation extend the convenience of SHs. Residents can manage various aspects of their homes from anywhere, ensuring security and efficiency. Speaking of security, SHs also enhance this aspect, with automated locks, surveillance systems, and alarms that offer peace of mind. Energy efficiency is another significant benefit. SHs use technology to optimize energy consumption, adjusting lighting, heating, and cooling based on real-time data, leading to cost savings and a reduced environmental impact.

Sub Question 1: *What is the state of the art regarding smart home devices and artificial intelligence used in the Built Environment?*

The integration of AI into SHDs was becoming more common. AI algorithms are being used to enhance the functionality and automation of devices like thermostats, lights, security cameras, and appliances. Research is done on SHDs with AI systems. However, on the market, understanding how smart these devices are and how well they can predict residential behavior might be challenging. It's important to note that this field's state of the art is continually evolving, with ongoing research and development in AI, IoT and SHTs. The current state of the art in SHDs and AI in the Built Environment is characterized by a significant focus on enhancing personalization, energy efficiency, and security. SHs are increasingly equipped with AI algorithms that learn and adapt to the preferences and behaviors of residents, leading to a more personalized living experience. This includes the automation of settings like lighting, temperature, and even entertainment systems.

To further understand the state of the art, it's essential to recognize the growing trends in AI for SHs, such as adaptive learning algorithms that personalize home environments, and predictive maintenance that anticipates device servicing needs. Additionally, advancements in voice recognition and natural language processing are making user interactions more intuitive. Despite these developments, challenges like ensuring data privacy and overcoming compatibility issues between different device ecosystems remain critical areas for ongoing improvement.

Sub Question 2: *How can a smart house change the spatial relationship and function in a house?*

The spatial relationship within a house is the relationship between the connected spaces within the home. These spatial connections depend on the location of the rooms. A house can provide shelter and comfort for a resident but cannot interact with the resident. A SH can interact with its residents; it can monitor the residential behavior and, based on the patterns, can predict the actions of the residents and adapt the internal system to the user's needs. The house's rooms are more connected, and the house itself can adjust the indoor comfort through a SHS. A SH can detect unsafe situations and alarm the resident (or other family member). A SH can take some tasks of room the resident by automation and provide entertainment for the resident. A SH can take care of a resident using medical detection devices and collect this data for healthcare purposes.

Sub Question 3: *How can these smart and intelligent devices be implemented in the transformation of a smart house, and how will the architectural qualities of the house change?*

The implementation of smart and intelligent devices is based on the user's needs and the needs of the house. Most of the devices can be attached to a wall, for example, motion sensors or smart thermostats; other devices are applicable for windows, like a smart shading system or open/closed window automation. A SH will affect the indoor environmental qualities of the space. The architectural qualities of the house are more flexible in a SH and adaptable. Integrating health-monitoring technologies into SHs could require some structural modifications. This might involve retrofitting walls or designing them with conduits for wiring to seamlessly integrate sensors and devices, ensuring they have necessary power and data connections. Such changes could lead to thicker walls or specialized panels housing this technology, potentially affecting the home's aesthetics. Additionally, to ensure robust wireless connectivity, the materials used in construction might need to be chosen to avoid signal obstruction. Although these modifications are usually minimal, careful planning and attention to detail are crucial to maintain the home's visual appeal and functionality, making the physical structure a key part of the health-monitoring ecosystem. Transforming a house into a SH involves adding new technologies and thoughtful consideration of how these technologies interact with the home's existing structure, aesthetics, and functionality. The goal is to create a living space that is efficient, secure, comfortable, and adaptable to the needs of its occupants and provide for their well-being.

Sub Question 4: What are the steps to transform our current houses into smart houses?

The case study has resulted in a strategic blueprint for transforming a house into a SH. This transformation aims to enhance the well-being of its occupants through the integration of smart devices and the application of AI. For transforming a house into a SH it is important to understand what the residents' needs are and what the needs of the house are. The relationship between the house and the resident will improve by transforming the house into a SH because it will be more connected and interactive. The house can learn from the resident by monitoring the occupancy and understanding their needs, over time predictions can be made and the house can make decisions for the resident to improve the indoor comfort and to provide the resident with a secure safety system. The proposed plan is outlined as follows:

Begin with thoroughly analyzing the residents' needs. This involves understanding their lifestyle, health conditions, physical abilities, and daily activities. This step is crucial for developing a human-centric design that addresses current needs and anticipates future requirements. Consider incorporating feedback mechanisms to continually adapt to changing resident needs. The second step is assessing the house and which technology suits integration. This includes considering the potential for energy efficiency improvements and how they can contribute to a healthier indoor environment. The third step is a detailed analysis of the house's interaction with its environment. This should include studying natural light availability, weather patterns, energy consumption, and radiance. The goal is to create a SHS that is efficient and environmentally sustainable. Step four involves utilizing the insights from the assessments to develop a comprehensive transformation plan. This plan should integrate technological solutions and potential spatial modifications to ensure seamless integration of smart systems. The design should be flexible to accommodate future technological advancements and changing resident needs. Step five includes selecting appropriate SHDs and sensors and prioritizing interoperability and user-friendliness. Integrate AI technologies to enhance the system's adaptability and responsiveness. AI can be used for predictive maintenance, personalized settings, and improving overall system efficiency based on user behavior patterns. The last step is comprehensive support for the residents to ensure they are comfortable and proficient in using the SHS. This step is crucial for maximizing the benefits of the technology and ensuring its effective use in daily life. (Figure 78)

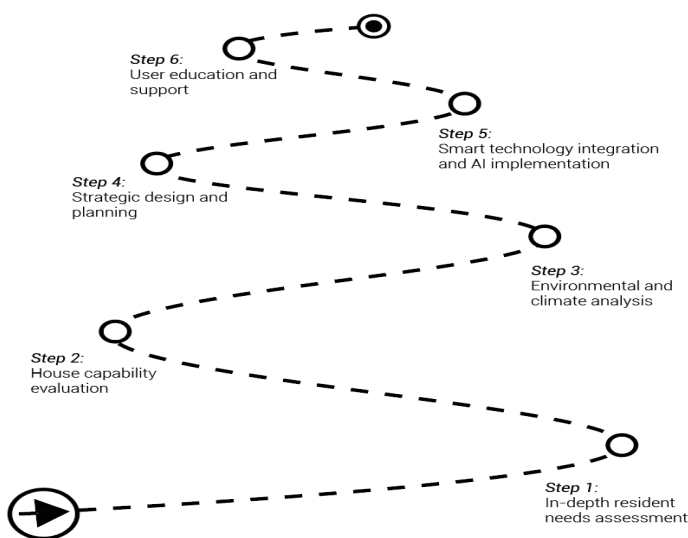

Figure 78: Roadmap for transforming a house into a Smart Home, made by author.

Background Question 1: *What are the differences between smart and intelligent devices, and what are the expectations for the future?*

The biggest difference between smart and intelligent is that smart is adaptable, and intelligent is reactive. Different types of intelligence are used in SHDs that can be categorized into four different intelligences: mechanical, analytical, intuitive, and empathetic intelligence. While smart devices offer enhanced functionality and connectivity, intelligent devices take this a step further with AI-driven learning and adaptability. Future intelligent devices will offer greater autonomy in decision-making and actions. Personalization will also be enhanced, with devices understanding individual preferences and needs more accurately. As devices become more connected and intelligent, there will be a heightened focus on ensuring data privacy and security.

Background Question 2: *How does the surroundings of a house influence the transforming the house into a smart house?*

The surrounding influences the transformation of the house by the grid sizes of the house and the buildings in the surrounding of the house. A semi-detached house has different transformation possibilities than a detached house. The climate of the location of the house influences the SH transformation and their requirement. The local climate plays a crucial role in determining the types of smart devices needed. For instance, in areas with extreme temperatures, smart thermostats and heating/cooling systems become essential for maintaining comfort. The surrounding environment can impact the choice of SH features. For example, homes in urban areas might focus more on noise reduction and air quality monitoring.

Background Question 3: *How does safety play a role in a smart house system?*

Safety is an important factor for a SHS; most SHDs are connected to the IoT, and the data storage of the collected data should be secure. A SH can also provide safety by monitoring systems to check if the house wont have intruders and can alarm the residents or family members whenever there is an emergency case. SHSs often include advanced security features like smart cameras, motion detectors, and door/window sensors. These devices provide real-time monitoring and alert homeowners to any unusual activity, whether they are at home or away. SHs can be equipped with systems that automatically respond to emergencies.

Background Question 4: *What are the options for using artificial intelligence regarding a smart house for the well-being of a resident?*

Different AI functions are applied to current SHDs according to Guo et al. (2019):

1. Activity recognition
2. Data processing
3. Voice recognition
4. Image recognition
5. Decision-making
6. Prediction-making

Most of the SHDs are used in healthcare. AI plays a significant role in improving the well-being of residents in SHs. It accomplishes this by offering personalized assistance and health monitoring. AI systems continuously collect and analyze data from various sources, such as wearables, sensors, and cameras, to monitor residents' health and daily activities.

AI can be integrated with health monitoring devices to track vital signs like heart rate, blood pressure, and sleep patterns. This data can be used to detect early signs of health issues or to monitor ongoing conditions. For elderly residents, AI systems can detect falls and automatically call for help. These systems can also provide easy voice-activated communication with family members or emergency services. This data-driven approach allows AI to detect any irregularities or changes in vital signs or behaviors, alerting caregivers or healthcare providers in real-time. Moreover, AI-powered virtual assistants can provide personalized assistance, reminders for medication schedules, and even offer recommendations for maintaining a healthy lifestyle, thereby contributing to the overall well-being and safety of the residents.

Background Question 5: What benefits does a smart house system provide for the well-being of its resident?

Many articles have been written about health and SHs; when looking for well-being, most of the well-being articles were in the medical field about smart devices for healthcare. The connection between health, well-being, and indoor comfort was made. Looking at the definition of 'well-being,' Ross et al. (2020) explained that 'health' is one of the aspects related to 'well-being.' Further studies use different aspects of 'well-being' and 'health' and their relationship with the indoor environment. Related to the Built Environment, more studies have been done on the relationship between 'health' and the indoor environment. In conclusion, the relationship between well-being and the indoor environment is the relationship between well-being and health, and health and the indoor environment. As engineers, it is crucial to consider the resident's health for the indoor comfort of the house. SHs can monitor air quality, humidity, and other environmental factors, promoting better health. Systems can alert residents to poor air quality or allergens, and in some cases, automatically adjust to improve conditions.

Background Question 6: How can a grasshopper simulation help with the testing process in scenarios that are impossible to test in real life?

The Grasshopper simulations can help to assess the indoor climate of the house with the Ladybug Tools. By understanding the needs of the house, the following design decisions can be made and applied. This makes it possible to check these transformations and how this affects the indoor climate. Hypothetical design decisions can be applied and tested without the transformation in real life to look at what outcomes certain design decisions will have. Grasshopper simulations can play a crucial role in the testing process, especially for scenarios that are impossible or impractical to test in real life. Simulations can provide detailed data that might be difficult or impossible to collect in real life. This data can be used for in-depth analysis, improving understanding and guiding future developments of a design.

4.3 Reflection

This reflection on the graduation project evaluates the approach, understanding, and feedback during this thesis. The value of the impact of this project will be discussed on an academic and social level, including ethical considerations. A reflection on the relationship between the main objective and the master track is included.

The interdisciplinary approach of this thesis is positioned as a forward-thinking, interdisciplinary project within the studio, aligning with technological innovation, sustainable design, and social responsibility themes. It contributes to the academic environment and practical applications in the field, offering educational value and potential for future research and collaboration. The relationship between "Transforming an existing house into a smart house to provide for the resident's well-being" became clearer during this project. Well-being is a broad definition, and it is associated with health. However, looking deeper into this definition, many studies have been done on the relationship between the Built Environment and health. This project put a focus on the indoor environment. By understanding the principles of building technology, like building systems, energy efficiency, and sustainability, a design can help refine and improve this. With a combination of interdisciplinary fields such as Architecture and the Built Environment, personal health, and a deeper understanding of technical innovations such as AI, this thesis explored the possibilities for the future by taking a computational approach, including focusing on the material use, climate design, structure and other things related to the technical aspect of the building.

The project's integrating of architectural principles with cutting-edge technologies such as AI and SHSs exemplifies a forward-thinking approach vital for addressing contemporary challenges within the Built Environment. The primary focus of this design was on improving indoor health and implementing smart technologies. Ethical considerations regarding potential privacy issues related to SHDs and data storage require careful future consideration. Moreover, the financial aspect is of paramount importance. While this thesis did not explicitly delve into cost implications, it is critical for homeowners contemplating a similar transformation of their residences. The envisioned innovation within the project, particularly including a kinetic shading system, has been successfully realized. This system significantly enhances energy efficiency and indoor comfort, seamlessly integrating with the SH infrastructure while adding functional and aesthetic value to the building. This achievement represents a significant advancement in SHs and sustainable design technologies.

The methods, findings, and recommendations can be used in many residential settings and for various building types. This project has the potential to act as a guide for not only researchers, architects, and engineers seeking to incorporate SHTs into their work but also for companies creating these SHDs. By collaborating with engineers, these companies can gain access to tools for modeling their devices, thereby enabling more accurate simulations and improved overall performance.

In conclusion, this graduation thesis allowed me to delve into the world of SHTs, contributing valuable insights to the field of building technology and enhancing my understanding of the relationship between technology and the well-being of residents. Integrating the adaptive kinetic shading system optimizes heat gains in winter and prevents overheating in summer, minimizing the need for air conditioning. The project positively impacts socio-cultural and ethical aspects by promoting sustainable living and environmental responsibility. It serves as a model for energy-efficient living, influencing community norms and demonstrating a commitment to reducing carbon footprints through green technologies. The design challenges conventional architectural norms, introducing innovative aesthetics and functions, and it exemplifies how architecture can align with environmental responsibility and set new standards in the construction industry.



V REFERENCES

Bibliography:

- Abbas, A. (2023). The Advantages and Challenges of Smart Facades Toward Contemporary Sustainable Architecture. *Journal of Engineering Research*, 7(4), 127–145. <https://doi.org/10.21608/erjeng.2023.325573>
- Agee, P., Gao, X., Paige, F., McCoy, A., & Kleiner, B. (2021a). A human-centred approach to smart housing. *Building Research and Information*, 49(1), 84–99. <https://doi.org/10.1080/09613218.2020.1808946>
- Agee, P., Gao, X., Paige, F., McCoy, A., & Kleiner, B. (2021b). A human-centred approach to smart housing. *Building Research and Information*, 49(1), 84–99. <https://doi.org/10.1080/09613218.2020.1808946>
- Alshammari, N., Alshammari, T., Sedky, M., Champion, J., & Bauer, C. (2017). OpenSHS: Open Smart Home Simulator. *Sensors* 2017, Vol. 17, Page 1003, 17(5), 1003. <https://doi.org/10.3390/S17051003>
- Arora, Y., & Pant, H. (2019). *Home Automation System with the use of Internet of Things and Artificial Intelligence*.
- Buckman, A. H., Mayfield, M., & Beck, S. B. M. (2014). *What is a Smart Building?* <https://doi.org/10.1108/SASBE-01-2014-0003>
- Buurt Erflanden (gemeente Hoogeveen) in cijfers en grafieken | AlleCijfers.nl*. (n.d.). Retrieved October 9, 2023, from <https://allecijfers.nl/buurt/erflanden-hoogeveen/>
- Chen, M., Yang, J., Zhu, X., Wang, X., Liu, M., & Song, J. (2017). Smart Home 2.0: Innovative Smart Home System Powered by Botanical IoT and Emotion Detection. *Mobile Networks and Applications*, 22(6), 1159–1169. <https://doi.org/10.1007/s11036-017-0866-1>
- Chi, O. H., Denton, G., & Gursoy, D. (2020). Artificially intelligent device use in service delivery: a systematic review, synthesis, and research agenda. *Journal of Hospitality Marketing and Management*, 29(7), 757–786. <https://doi.org/10.1080/19368623.2020.1721394>
- Colstra, J. (2018). *The Evolving Architecture of Smart Cities*.
- Deserno, T. M. (2020). Transforming Smart Vehicles and Smart Homes into Private Diagnostic Spaces. *ACM International Conference Proceeding Series*, 165–171. <https://doi.org/10.1145/3379310.3379325>
- D'Ulizia, A., Ferri, F., Grifoni, P., & Guzzo, T. (2010). Smart Homes to Support Elderly People: Innovative Technologies and Social Impacts. <https://Services.Igi-Global.Com/Resolvedoi/Resolve.aspx?Doi=10.4018/978-1-61520-765-7.Ch002>, 25–38. <https://doi.org/10.4018/978-1-61520-765-7.CH002>
- Dusseldorp, A., Van Bruggen, M., Douwes, J., Janssen, P. J. C. M., & Kelfkens, G. (2007). *Health-based guideline values for the indoor environment*. <https://www.rivm.nl/bibliotheek/rapporten/609021044.pdf>
- EPW Map*. (n.d.). Retrieved September 21, 2023, from <https://www.ladybug.tools/epwmap/>
- Gezondheid en zorggebruik; persoonskenmerken, 2014-2021*. (2023, January 9). <https://www.cbs.nl/nl-nl/cijfers/detail/83005NED>

- Ghosh, S. (2018). *Smart Homes: Architectural and Engineering Design Imperatives for Smart City Building Codes*.
- Gunge, V. S., & Yalagi, P. S. (2016). Smart Home Automation: A Literature Review. In *International Journal of Computer Applications*.
- Guo, X., Shen, Z., Zhang, Y., & Wu, T. (2019). *Review on the Application of Artificial Intelligence in Smart Homes*. <https://doi.org/10.3390/smartcities2030025>
- Harper, R. (2003). *Inside the Smart Home: Ideas, Possibilities and Methods*.
- Hawkins, L. E. (2023, April 23). *Future of Smart Homes: Here's What You Need to Know | Nasdaq*. <https://www.nasdaq.com/articles/future-of-smart-homes:-heres-what-you-need-to-know>
- Hayes, A. (2022, September 14). *Smart Home: Definition, How They Work, Pros and Cons*. <https://www.investopedia.com/terms/s/smart-home.asp>
- Heinzerling, D., Schiavon, S., Webster, T., & Arens, E. (2013). *Indoor environmental quality assessment models: A literature review and a proposed weighting and classification scheme*. <https://doi.org/10.1016/j.buildenv.2013.08.027>
- Herczeg, M. (2010). *The Smart, the Intelligent and the Wise: Roles and Values of Interactive Technologies*.
- Historische Kring Hoogeveen*. (n.d.). Retrieved October 9, 2023, from <https://www.historischekringhoogeveen.nl/geschiedenis>
- Home Assistant*. (n.d.). Retrieved September 11, 2023, from <https://www.home-assistant.io/>
- Hosseini, S. M., Mohammadi, M., Rosemann, A., Schröder, T., & Lichtenberg, J. (2019). A morphological approach for kinetic façade design process to improve visual and thermal comfort: Review. *Building and Environment*, 153, 186–204. <https://doi.org/10.1016/J.BUILDENV.2019.02.040>
- Introduction to Indoor Air Quality | US EPA*. (2022). <https://www.epa.gov/indoor-air-quality-iaq/introduction-indoor-air-quality>
- Juliana, N., Mallongi, A., & Megasari, W. O. (2021). Analysis Of Humidity, Temperature, Working Period, And Personal Protective Equipment In Home Industry At Gold Craftsmen. *Jurnal Ilmu Kesehatan*, 9(2), 81–89. <https://doi.org/10.30650/JIK.V9I2.2995>
- Kaboli, A., & Shirowzhan, S. (2021). *Advances and technologies in building construction and structural analysis*.
- Kim, M. J., Cho, M. E., & Jun, H. J. (2020). Developing Design Solutions for Smart Homes Through User-Centered Scenarios. *Frontiers in Psychology*, 11, 516355. <https://doi.org/10.3389/FPSYG.2020.00335/BIBTEX>
- Kraus, M. A., & Drass, M. (2020). Artificial intelligence for structural glass engineering applications – overview, case studies and future potentials. *Glass Structures and Engineering*, 5(3), 247–285. <https://doi.org/10.1007/s40940-020-00132-8>
- Krüger, E. L. (2015). Urban heat island and indoor comfort effects in social housing dwellings. *Landscape and Urban Planning*, 134, 147–156. <https://doi.org/10.1016/J.LANDURBPLAN.2014.10.017>

- Kum, S. W., Kang, M., & Park, J. II. (2016). Iot delegate: Smart home framework for heterogeneous iot service collaboration. *KSII Transactions on Internet and Information Systems*, 10(8), 3958–3971. <https://doi.org/10.3837/tiis.2016.08.029>
- Ladybug Light Analysis - TOI-Pedia*. (n.d.). Retrieved September 16, 2023, from http://wiki.bk.tudelft.nl/toi-pedia/Ladybug_Light_Analysis
- Ladybug Tools | Home Page*. (n.d.). Retrieved September 11, 2023, from <https://www.ladybug.tools/>
- Lee, D. S., Koo, S. H., Seong, Y. B., & Jo, J. H. (2016). Evaluating thermal and lighting energy performance of shading devices on kinetic façades. *Sustainability (Switzerland)*, 8(9). <https://doi.org/10.3390/su8090883>
- Liao, J., Cui, X., & Kim, H. (2023). Mapping a Decade of Smart Homes for the Elderly in Web of Science: A Scientometric Review in CiteSpace. *Buildings*, 13(7), 1581. <https://doi.org/10.3390/buildings13071581>
- Life expectancy - The Netherlands on the European scale | 2019 | CBS*. (n.d.). Retrieved April 29, 2023, from <https://longreads.cbs.nl/european-scale-2019/life-expectancy/>
- Lin, H., & Bergmann, N. W. (2016). IoT privacy and security challenges for smart home environments. *Information (Switzerland)*, 7(3). <https://doi.org/10.3390/info7030044>
- Lin, V. Z., & Parkin, S. (2020, December 14). Transferability of privacy-related behaviours to shared smart home assistant devices. *2020 7th International Conference on Internet of Things: Systems, Management and Security, IOTSMS 2020*. <https://doi.org/10.1109/IOTSMS52051.2020.9340199>
- Ma, C., Guerra-Santin, O., & Mohammadi, M. (2022). Smart home modification design strategies for ageing in place: a systematic review. *Journal of Housing and the Built Environment*, 37(2), 625–651. <https://doi.org/10.1007/S10901-021-09888-Z/TABLES/2>
- Majumder, S., Aghayi, E., Noferesti, M., Memarzadeh-Tehran, H., Mondal, T., Pang, Z., & Deen, M. J. (2017). Smart homes for elderly healthcare—Recent advances and research challenges. In *Sensors (Switzerland)* (Vol. 17, Issue 11). MDPI AG. <https://doi.org/10.3390/s17112496>
- Moffeq, M., Al-Sarraf, A., Alobeidi, M. M., & Alsarraf, A. A. (2018). The Impact of the use of Smart Materials on the Facades of Contemporary Buildings. *International Journal of Engineering & Technology*, 744–750. <https://doi.org/10.13140/RG.2.2.18405.65764>
- Mohtashami, N., Mahdavinejad, M., & Bemanian, M. (2016). Contribution of City Prosperity to Decisions on Healthy Building Design: A case study of Tehran. *Frontiers of Architectural Research*, 5(3), 319–331. <https://doi.org/10.1016/j.foar.2016.06.001>
- Nearly three quarters of the Dutch population use smart devices | CBS*. (2022, January 25). <https://www.cbs.nl/en-gb/news/2021/48/nearly-three-quarters-of-the-dutch-population-use-smart-devices>
- Nederlanders hebben gemiddeld 53 vierkante meter woonoppervlakte - Vastgoed Actueel*. (n.d.). Retrieved September 15, 2023, from <https://vastgoedactueel.nl/nederlanders-hebben-gemiddeld-53-m2-woonoppervlakte/>

- Needham, M. (2022, April 25). *Worldwide Smart Home Devices Market Grew 11.7% in 2021 with Double-Digit Growth Forecast Through 2026, According to IDC*. <https://www.idc.com/getdoc.jsp?containerId=prUS49051622>
- Nicklas, J.-P., Mamrot, M., Winzer, P., Lichte, D., Marchlewitz, S., & Wolf, K.-D. (2016). *Use Case based Approach for an Integrated Consideration of Safety and Security Aspects for Smart Home Applications*.
- Nikoofard, S., Ugursal, V. I., & Beausoleil-Morrison, I. (2011). Effect of external shading on household energy requirement for heating and cooling in Canada. *Energy and Buildings*, 43, 1627–1635. <https://doi.org/10.1016/j.enbuild.2011.03.003>
- Norman, D. (2013). *THE DESIGN OF EVERYDAY THINGS REVISED AND EXPANDED EDITION*.
- Onio Figueiredo, A., Figueira, J. E., Vicente, R., & Maio, R. (2016). *Thermal comfort and energy performance: Sensitivity analysis to apply the Passive House concept to the Portuguese climate*. <https://doi.org/10.1016/j.buildenv.2016.03.031>
- Osama, Y. (2014). *INTERACTIVE MOVEMENT IN KINETIC ARCHITECTURE* (Vol. 42, Issue 3).
- Osibona, O., Solomon, B. D., & Fecht, D. (2021). Lighting in the home and health: A systematic review. In *International Journal of Environmental Research and Public Health* (Vol. 18, Issue 2, pp. 1–20). MDPI AG. <https://doi.org/10.3390/ijerph18020609>
- Ouderenzorg onder grote druk: nog meer ouderen moeten voor zichzelf zorgen*. (2022, November 24). NOS. <https://nos.nl/nieuwsuur/artikel/2453794-ouderenzorg-onder-grote-druk-nog-meer-ouderen-moeten-voor-zichzelf-zorgen>
- Over Hoogeveen - Gemeente Hoogeveen*. (n.d.). Retrieved October 9, 2023, from <https://www.hoogeveen.nl/over-de-gemeente/over-hoogeveen>
- Phong House / VHL.Architecture | ArchDaily*. (n.d.). Retrieved June 10, 2023, from <https://www.archdaily.com/889686/phong-house-vhrchitecture>
- Pille, A. E. (2019). *Empower people's perception of air and their ability to improve indoor air quality*.
- Planbureau, S. en C., & Roeters, A. (2018). Personal care | Time use in the Netherlands: Edition 1. *Time Use in the Netherlands: Edition 1*. <https://digital.scp.nl/timeuse1/personal-care>
- Prognose: in 2035 vooral meer inwoners in en om grotere gemeenten | CBS*. (2022). <https://www.cbs.nl/nl-nl/nieuws/2022/27/prognose-in-2035-vooral-meer-inwoners-in-en-om-grotere-gemeenten>
- Qian, K., Zhang, Z., Yamamoyo, Y., & Schuller, B. W. (2021, July). *Artificial Intelligence Internet of Things for the Elderly*. <https://ieeexplore.ieee.org/stamp/stamp.jsp?tp=&arnumber=9467679>
- Razzaghmanesh, M., Beecham, S., & Salemi, T. (2016). The role of green roofs in mitigating Urban Heat Island effects in the metropolitan area of Adelaide, South Australia. *Urban Forestry & Urban Greening*, 15, 89–102. <https://doi.org/10.1016/j.ufug.2015.11.013>
- Reaz. (2013). *Artificial Intelligence technologies for advances smart home impelemtation*.

- Rego, A., Ramírez, P. L. G., Jimenez, J. M., & Lloret, J. (2022). Artificial intelligent system for multimedia services in smart home environments. *Cluster Computing*, 25(3), 2085–2105. <https://doi.org/10.1007/s10586-021-03350-z>
- Ross, D. A., Hinton, R., Melles-Brewer, M., Engel, D., Zeck, W., Fagan, L., Herat, J., Phaladi, G., Imbago-Jácome, D., Anyona, P., Sanchez, A., Damji, N., Terki, F., Baltag, V., Patton, G., Silverman, A., Fogstad, H., Banerjee, A., & Mohan, A. (2020). Adolescent Well-Being: A Definition and Conceptual Framework. *Journal of Adolescent Health*, 67(4), 472–476. <https://doi.org/10.1016/j.jadohealth.2020.06.042>
- Sam Kubba. (2010). *Indoor Environmental Quality*. <https://doi.org/10.1016/B978-1-85617-691-0.00007-2>
- Sepasgozar, S., Karimi, R., Farahzadi, L., Moezzi, F., Shirowzhan, S., Ebrahimzadeh, S. M., Hui, F., & Aye, L. (2020). A systematic content review of artificial intelligence and the internet of things applications in smart home. *Applied Sciences (Switzerland)*, 10(9). <https://doi.org/10.3390/app10093074>
- Smart home - statistics & facts | Statista*. (n.d.). Retrieved April 29, 2023, from <https://www.statista.com/topics/2430/smart-homes/#topicOverview>
- Smart Homes That Use Domotics To Improve Quality of Life | ArchDaily*. (n.d.). Retrieved September 23, 2023, from <https://www.archdaily.com/906374/smart-homes-that-use-domotics-to-improve-quality-of-life>
- Steeds meer Nederlanders gebruiken slimme apparaten | Centraal Bureau voor Statistiek*. (2022, December 16). <https://www.cbs.nl/nl-nl/nieuws/2022/50/steeds-meer-nederlanders-gebruiken-slimme-apparaten>
- Suzuki, H., Kiyonobu, Y., Mogi, T., Matsushita, K., Hanada, M., Suzuki, R., & Niijima, N. (2018). *An Updated Watch-over System Using an IoT Device, for Elderly People Living by Themselves*.
- van der Staak, M., Schilder, F., & Daalhuizen, F. (2020). *Samen en oud in 2030*.
- Vazquez, F. I., & Kastner, W. (2012). *Advances in Intelligent and Soft Computing 153 Editor-in-Chief*. <http://www.springer.com/series/4240>
- Verkocht: Meerval 39 7908 WT Hoogeveen [funda]*. (n.d.). Retrieved May 25, 2023, from <https://www.funda.nl/koop/verkocht/hoogeveen/huis-42934048-meerval-39/>
- Vrooman, R. M. (2017). *Enhancing Privacy in Smart Home Ecosystems Using Cryptographic Primitives and a Decentralized Cloud Entity*. <http://repository.tudelft.nl/>
- "Welkom in de slimste woning van Nederland."* (n.d.). Retrieved August 30, 2023, from <https://www.thuiscomfort.nl/content/thuiscomfort/interviews/smarthomes-slimste-woning-van-nederland-.html#>
- Wilson, C., Hargreaves, T., & Hauxwell-Baldwin, R. (2017). Benefits and risks of smart home technologies. *Energy Policy*, 103, 72–83. <https://doi.org/10.1016/J.ENPOL.2016.12.047>
- Woningvoorraad; woningtype op 1 januari, regio*. (n.d.). Retrieved September 15, 2023, from <https://www.cbs.nl/nl-nl/cijfers/detail/85035NED>

- Woonplaats Hoogeveen in cijfers en grafieken| AlleCijfers.nl. (n.d.). Retrieved October 9, 2023, from <https://allecijfers.nl/woonplaats/hoogeveen/>
- Yang, H., Lee, W., & Lee, H. (2018). IoT Smart Home Adoption: The Importance of Proper Level Automation. *Journal of Sensors*, 2018. <https://doi.org/10.1155/2018/6464036>
- Yang, R., & Newman, M. W. (2013). Learning from a learning thermostat: Lessons for intelligent systems for the home. *UbiComp 2013 - Proceedings of the 2013 ACM International Joint Conference on Pervasive and Ubiquitous Computing*, 93–102. <https://doi.org/10.1145/2493432.2493489>
- Yang, T., Zhao, L., Li, W., Wu, J., & Zomaya, A. Y. (2021). Towards healthy and cost-effective indoor environment management in smart homes: A deep reinforcement learning approach. *Applied Energy*, 300. <https://doi.org/10.1016/j.apenergy.2021.117335>
- Zainuddin, N., Daud, M., Ahmad, S., Maslizan, M., & Abdullah, S. A. L. (2021). A study on privacy issues in internet of things (IoT). *2021 IEEE 5th International Conference on Cryptography, Security and Privacy, CSP 2021*, 96–100. <https://doi.org/10.1109/CSP51677.2021.9357592>



VI APPENDICES

Appendix A: An Insight into the Smart Home Device Market: Interview with Signify

What is the company's focus, and what products and services do they offer in the smart home market?

"We focus on selling Smart lighting products for the Consumer market in the Benelux. "

To what extent does the company use AI in developing its services?

"Artificial intelligence is a broad concept, but one example is the Awakening Home function on our Philips Hue lighting. For instance, you can activate a function on vacation where the lights turn on at different times each day to deter potential intruders. These are some of the features that are implemented in the app. Another feature is that when you drive home, the smart lighting system recognizes that your phone is near your home and can turn the lights on. We currently have lighting in many office buildings, with sensors and a cloud service behind it. We can analyze the number of hours someone has sat at a workstation, which days the workstations were occupied, and whether a cleaner need to clean it, among many other possible functionalities. We can perform various measurements per workstation per zone. It is currently a measuring and control system."

What were the technology challenges faced by the company, and how were they resolved?

"One of the biggest challenges is the privacy challenge."

How does the company incorporate computational design in its approach to smart home solutions?

"No"

How does the company address privacy and security concerns related to AI in its smart home technology?

"We also deal with privacy issues, with questions about what we do or do not want to implement regarding privacy. Our servers and customer data are located close to home. As a result, we know that the data is secure. We must deal with certain security certificates that we must have. Safety is our top priority to prevent data leaks. We try to prevent data from being leaked through continuous updates in the app. Additionally, the risk is much lower with our product because we do not have built-in speakers, and the devices do not listen in. "

Are there any upcoming innovative products or features from the company, and how does it approach technological research and advancements?

"There are studies from the distribution department looking at possibilities for the future. For example, 'We see you leave your home every morning. Should we program your lights differently?' This is mainly in the pipeline for the future. We work with an innovation calendar and cannot immediately release the latest developments on the market because there will be no products to add in the upcoming periods. It is necessary to bridge that time. Every calendar year, we look at innovations, and newer features are gradually released to add a little more and not all at once, as it is not a business model for companies. It will be implemented slowly. Expectations are a few years, and it is in its infancy, with many companies working with it. It is emerging, but we do not expect many companies to adapt their products to it within one or

two years of development. It will take a longer period. For example, the application of Tesla to drive hands-free, no country allows official hands-free driving yet. It concerns the development of ready technology and the government's opinion."

How does the company collaborate with architects, designers, and engineers to ensure successful smart home retrofit projects?

"Yes, we are mainly responsible for the consumer market. If a construction company or project developer asks us to make the smartest office in the Netherlands, we can provide professional solutions with available high-tech specialties.

How does the company contribute to the global development of smart home technology, and what is its approach in the Netherlands?

"We are leading, not just in smart homes, but in technology and equipment application. A manufacturer offers its products worldwide, but it's about the adoption of the products, and we are leading mainly in Europe. Voice control is primarily used in America and much less in the Netherlands. One simple reason could be that Google started in English, and in Dutch, it expanded much later. Google Assistant, Amazon, or Siri work much less well in Dutch than in English. For example, America is ahead in innovation adoption, but we are ahead in adopting smart devices in the Netherlands. If you look at the innovation adoption curve, the Netherlands is always in the early stages of adopting these initiatives."

Appendix B: Climate Analyses

Windrose script Ladybug:

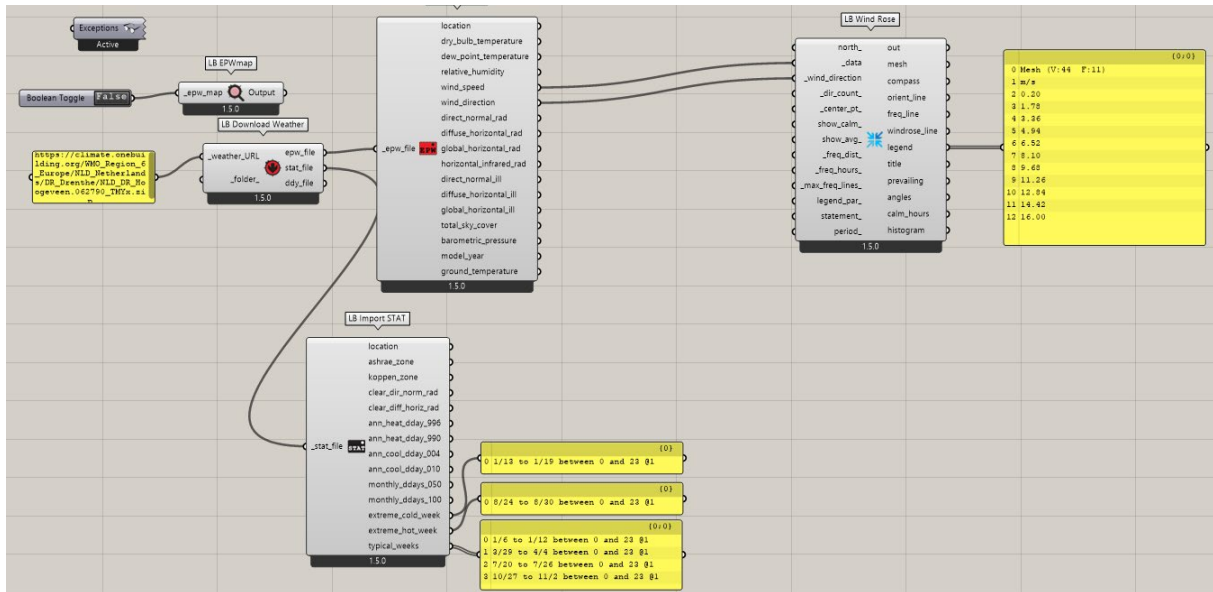

Based on outcomes of the simulations the weeks were the input to create the wind rose:

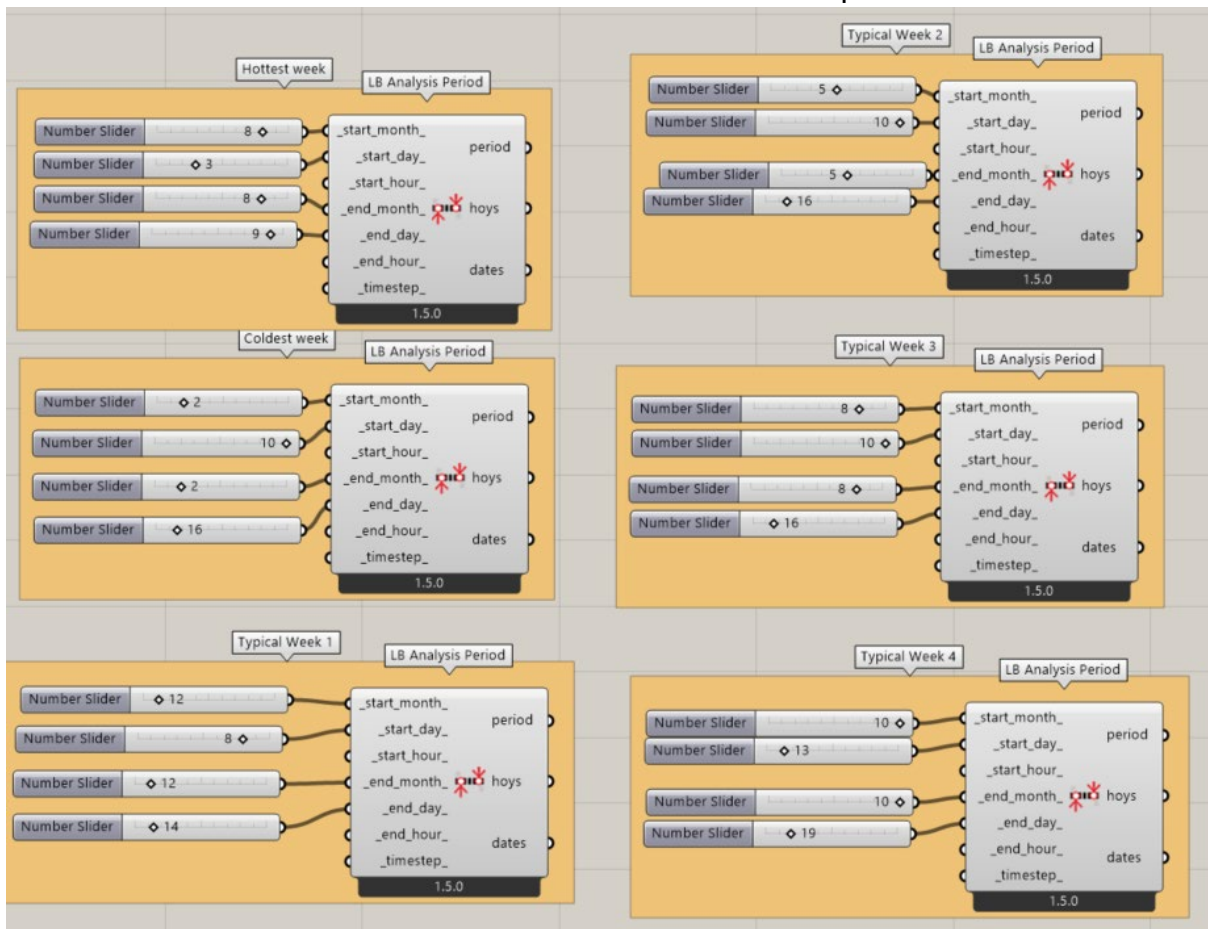

Sun analysis Ladybug script:

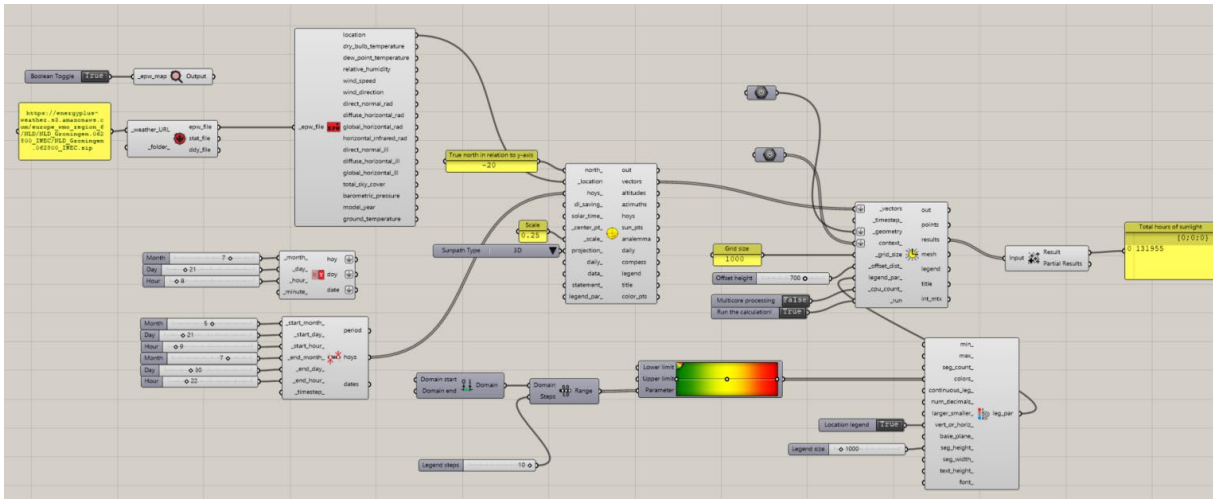

Butterfly air flow analysis, for house and context:

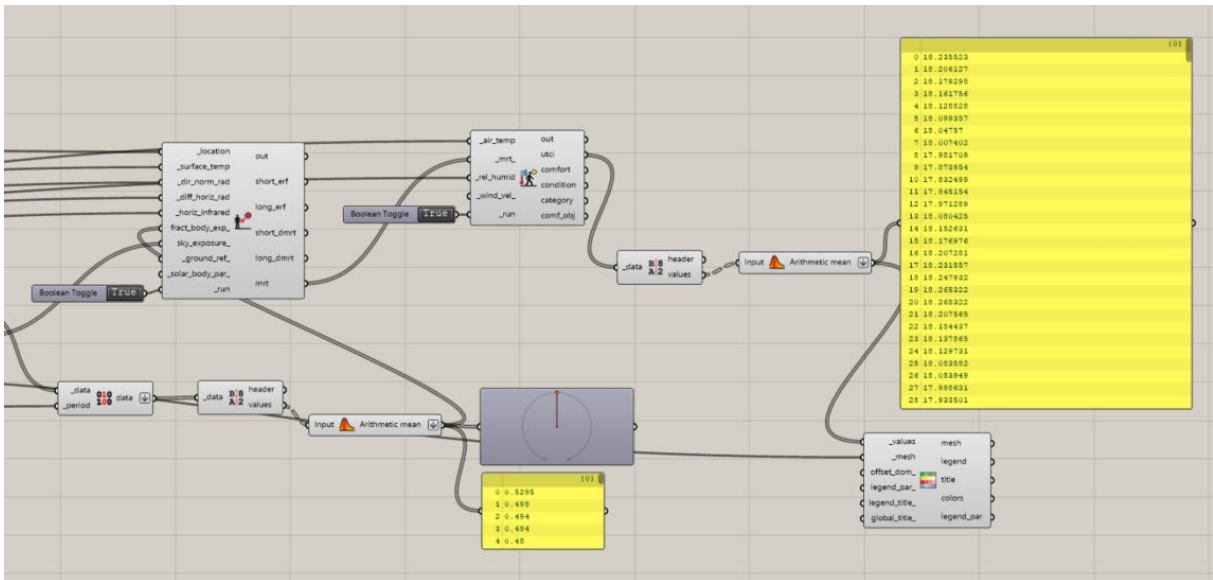
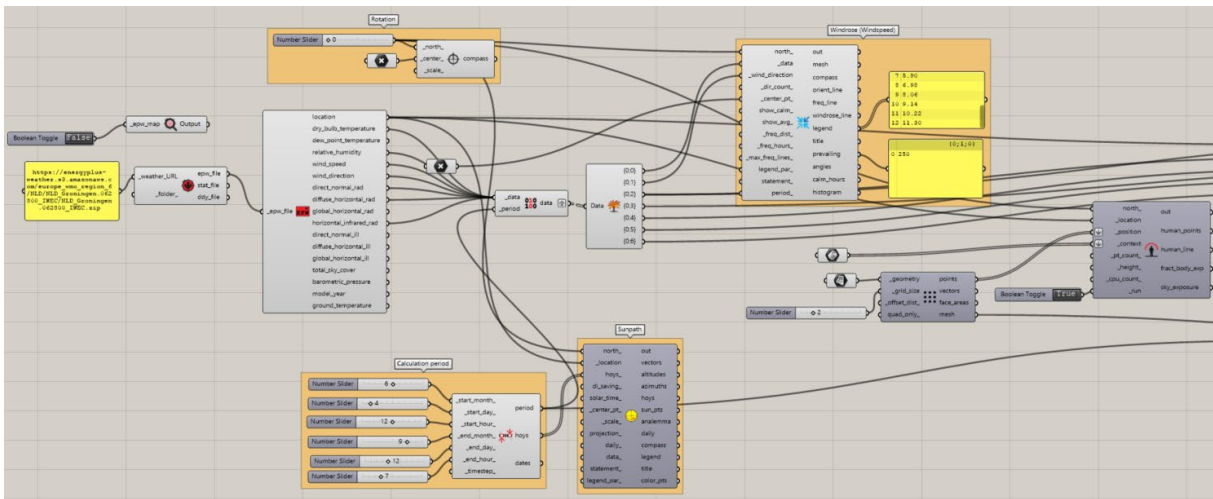

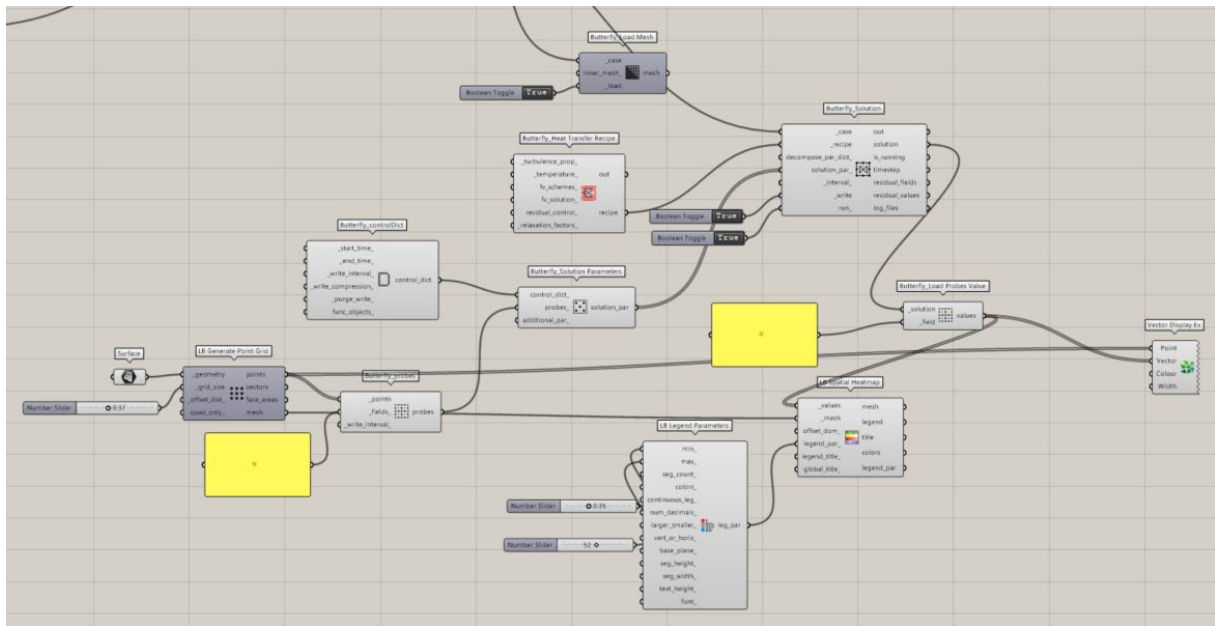

Appendix B: Honeybee Energy, cooling and heating load and Radiance analyses

Floor construction > Wall construction > program scheme > Base construction set > construction set up:

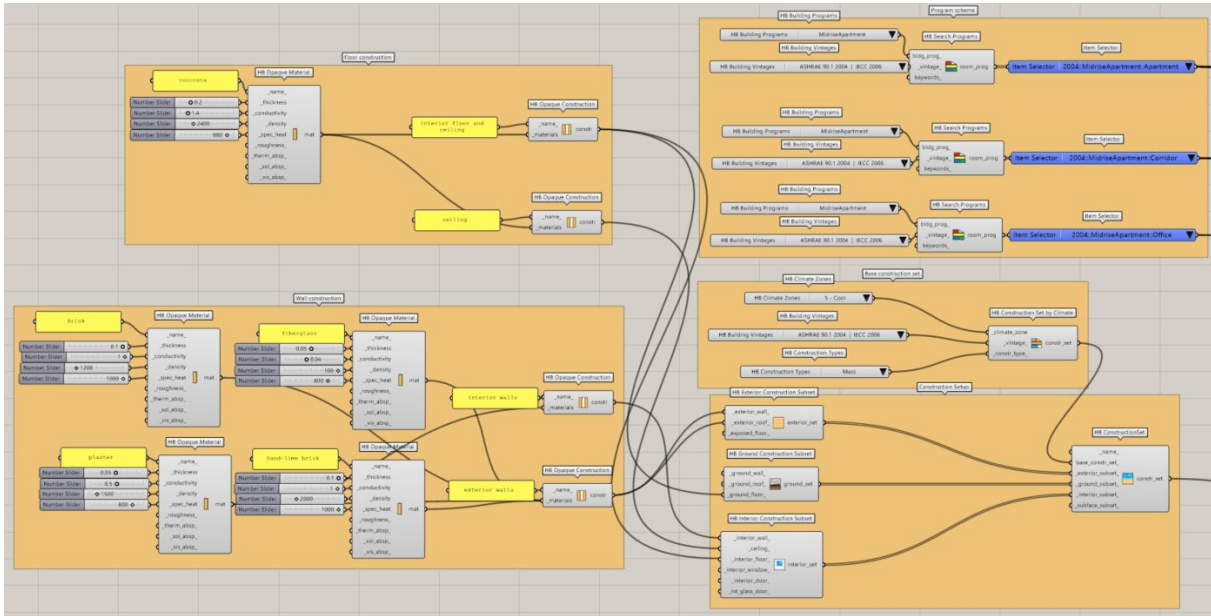

Building connection rhino to grasshopper, division of the rooms, Ground floor, > Location Weather Data > Climate zone check > Open Studio Simulation:

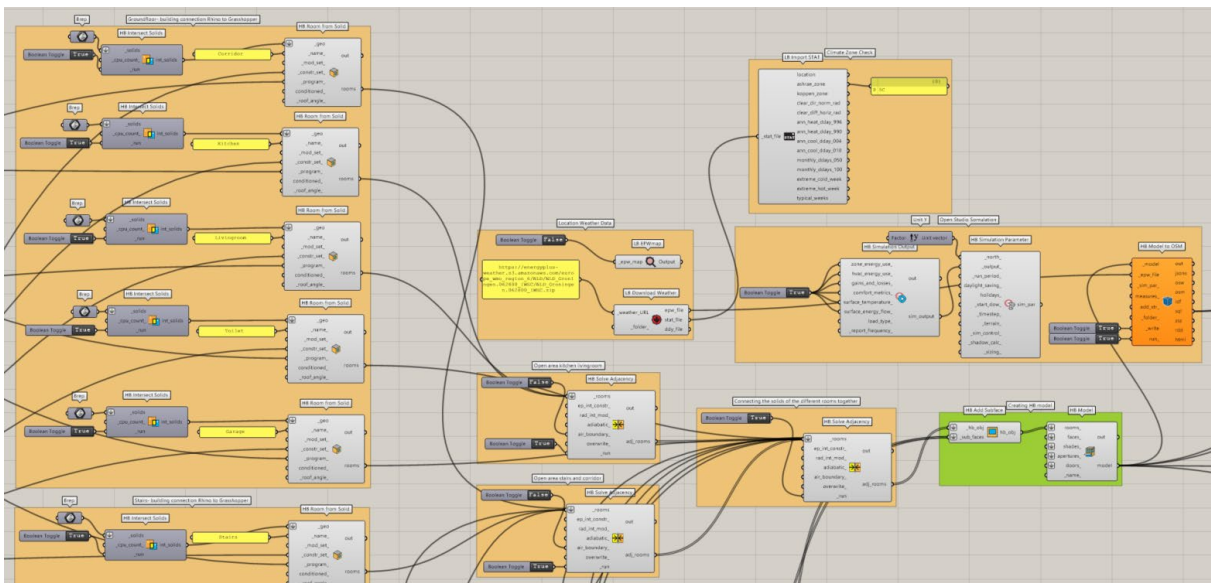

Set up rooms and program first floor and second floor> Windows and doors Apertures:

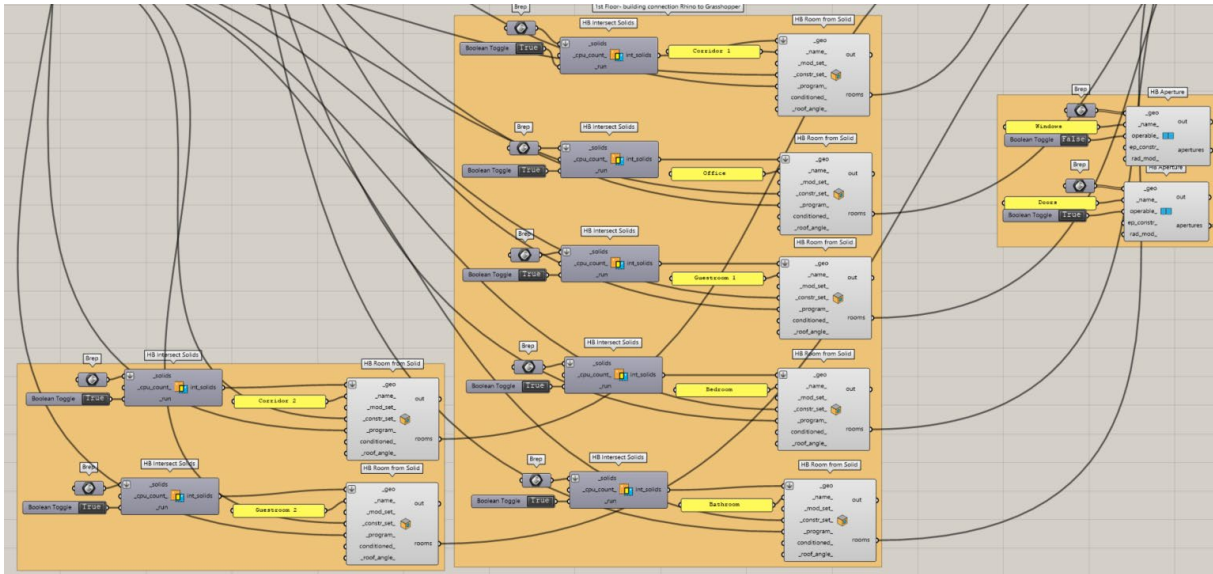

Reading results and HB Visualizing by type, Color room Results:

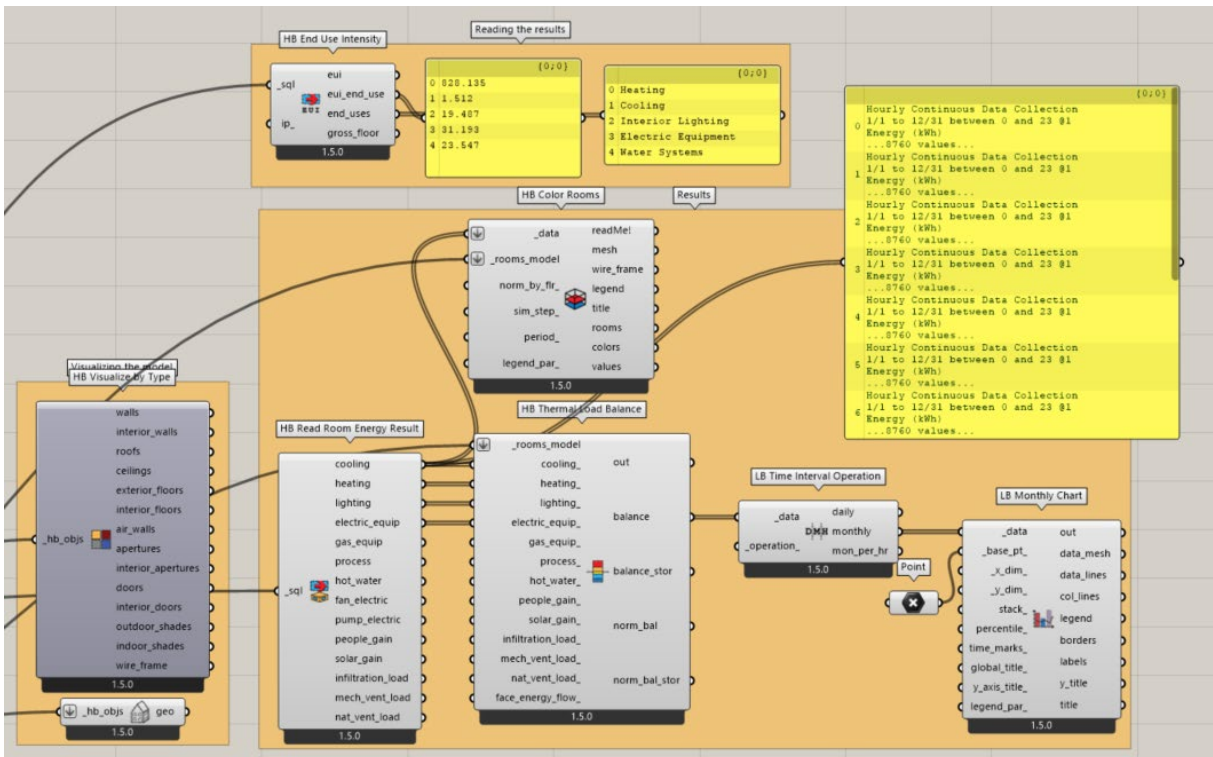

Appendix D: Façade experiments kinetic shading system

Façade experiment 1:

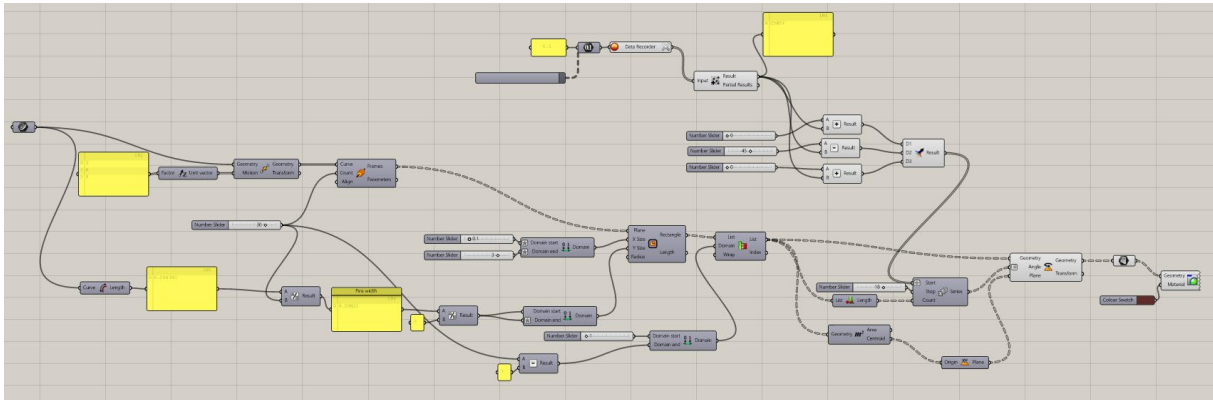

Façade experiment 2:

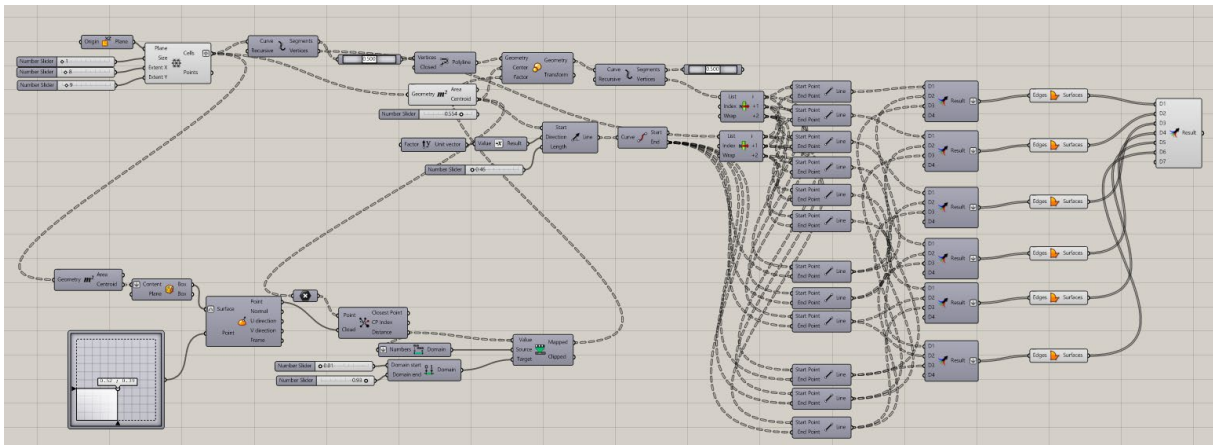

Façade experiment 3:

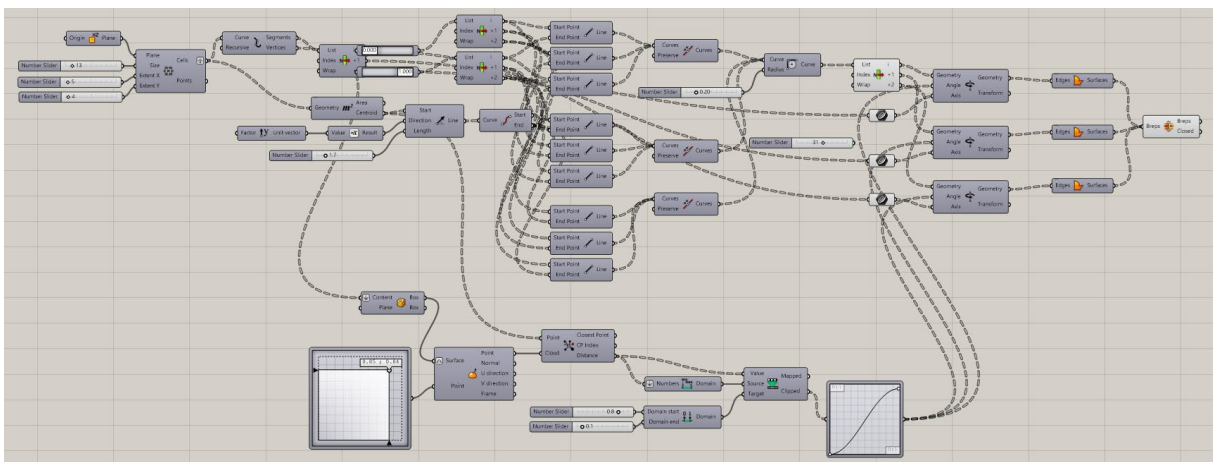

Appendix E: Home Assistant Coding Operating System Smart Home Design

```
# Default integrations
default_config:

# UI Themes
frontend:
  themes: !include_dir_merge_named themes/

# Core configurations
automation:

- alias: "Motion Sensor Light On with Lux Condition"
  trigger:
    platform: state
    entity_id: sensor.your_motion_sensor
    to: 'on'
  condition:
    - condition: numeric_state
      entity_id: sensor.your_light_sensor
      below: 500
  action:
    - service: light.turn_on
      entity_id: light.your_light
    - delay:
        minutes: 5
    - service: light.turn_off
      entity_id: light.your_light

- alias: "Smoke Detector Alert"
  trigger:
    platform: state
    entity_id: binary_sensor.smoke_detector # Replace with smoke detector's entity ID
    to: 'on' # Assuming 'on' means smoke detected
  action:
    service: notify.mobile_app_your_device # Replace with notification service
    data:
      message: 'Smoke detected in the house!'
      title: 'Smoke Alert!'

- alias: "Open Kitchen Window if Air is Polluted"
  trigger:
    platform: state
    entity_id: sensor.air_purity_sensor
    to: "not clean"
```

```

condition:
  - condition: state
    entity_id: sensor.temperature_sensor
    state: "not hot"
action:
  service: input_boolean.turn_on
  entity_id: input_boolean.window_kitchen

- alias: "Close Kitchen Window if Temperature is Hot"
  trigger:
    platform: numeric_state
    entity_id: sensor.temperature_sensor
    above: 24.5
  action:
    service: input_boolean.turn_off
    entity_id: input_boolean.window_kitchen

- alias: "Open Living Room Window if Air is Polluted"
  trigger:
    platform: state
    entity_id: sensor.air_purity_sensor
    to: "not clean"
  condition:
    - condition: state
      entity_id: sensor.temperature_sensor
      state: "not hot"
  action:
    service: input_boolean.turn_on
    entity_id: input_boolean.window_living_room

- alias: "Close Living Room Window if Temperature is Hot"
  trigger:
    platform: numeric_state
    entity_id: sensor.temperature_sensor
    above: 24.5
  action:
    service: input_boolean.turn_off
    entity_id: input_boolean.window_living_room

- alias: "Open Workspace Window if Air is Polluted"
  trigger:
    platform: state
    entity_id: sensor.air_purity_sensor
    to: "not clean"
  condition:
    - condition: state
      entity_id: sensor.temperature_sensor
      state: "not hot"
  action:

```

```

    service: input_boolean.turn_on
    entity_id: input_boolean.window_working_space

- alias: "Close Workspace Window if Temperature is Hot"
  trigger:
    platform: numeric_state
    entity_id: sensor.temperature_sensor
    above: 24.5
  action:
    service: input_boolean.turn_off
    entity_id: input_boolean.window_working_space

- alias: "Open Bedroom Window if Air is Polluted"
  trigger:
    platform: state
    entity_id: sensor.air_purity_sensor
    to: "not clean"
  condition:
    - condition: state
      entity_id: sensor.temperature_sensor
      state: "not hot"
  action:
    service: input_boolean.turn_on
    entity_id: input_boolean.window_bedroom

- alias: "Close Bedroom Window if Temperature is Hot"
  trigger:
    platform: numeric_state
    entity_id: sensor.temperature_sensor
    above: 24.5
  action:
    service: input_boolean.turn_off
    entity_id: input_boolean.window_bedroom

- alias: "Open Guest Room Windows if Air is Polluted"
  trigger:
    platform: state
    entity_id: sensor.air_purity_sensor
    to: "not clean"
  condition:
    - condition: state
      entity_id: sensor.temperature_sensor
      state: "not hot"
  action:
    service: input_boolean.turn_on
    entity_id: input_boolean.window_guest_room

- alias: "Close Guest Room Window if Temperature is Hot"
  trigger:

```

```

    platform: numeric_state
    entity_id: sensor.temperature_sensor
    above: 24.5
action:
    service: input_boolean.turn_off
    entity_id: input_boolean.window_guest_room

- alias: "Open Kitchen Window if Air is Polluted"
  trigger:
    platform: state
    entity_id: sensor.air_purity_sensor
    to: "not clean"
  condition:
    - condition: state
      entity_id: sensor.temperature_sensor
      state: "not hot"
  action:
    service: input_boolean.turn_on
    entity_id: input_boolean.window_kitchen

- alias: "Turn on Humidifier living room if Humidity is Low"
  trigger:
    platform: numeric_state
    entity_id: sensor.room_humidity
    below: 40
  condition:
    - condition: state
      entity_id: input_boolean.humidity_system_on
      state: "on"
  action:
    - service: input_boolean.turn_on
      entity_id: input_boolean.humidifier_on
    - service: input_boolean.turn_off
      entity_id: input_boolean.dehumidifier_on

- alias: "Turn off Humidifier living room if Humidity is high"
  trigger:
    platform: numeric_state
    entity_id: sensor.room_humidity
    above: 60
  condition:
    - condition: state
      entity_id: input_boolean.humidity_system_on
      state: "on"
  action:
    - service: input_boolean.turn_off
      entity_id: input_boolean.humidifier_on
    - service: input_boolean.turn_on
      entity_id: input_boolean.dehumidifier_on

```

```

- alias: "Turn on Humidifier bedroom if Humidity is Low"
  trigger:
    platform: numeric_state
    entity_id: sensor.room_humidity
    below: 40
  condition:
    - condition: state
      entity_id: input_boolean.humidity_system_on
      state: "on"
  action:
    - service: input_boolean.turn_on
      entity_id: input_boolean.humidifier_on
    - service: input_boolean.turn_off
      entity_id: input_boolean.dehumidifier_on

- alias: "Turn off Humidifier bedroom if Humidity is high"
  trigger:
    platform: numeric_state
    entity_id: sensor.room_humidity
    above: 60
  condition:
    - condition: state
      entity_id: input_boolean.humidity_system_on
      state: "on"
  action:
    - service: input_boolean.turn_off
      entity_id: input_boolean.humidifier_on
    - service: input_boolean.turn_on
      entity_id: input_boolean.dehumidifier_on

- alias: "Turn on Humidifier guestroom if Humidity is Low"
  trigger:
    platform: numeric_state
    entity_id: sensor.room_humidity
    below: 40
  condition:
    - condition: state
      entity_id: input_boolean.humidity_system_on
      state: "on"
  action:
    - service: input_boolean.turn_on
      entity_id: input_boolean.humidifier_on
    - service: input_boolean.turn_off
      entity_id: input_boolean.dehumidifier_on

- alias: "Turn off Humidifier guestroom if Humidity is high"
  trigger:
    platform: numeric_state
    entity_id: sensor.room_humidity

```



```

    above: 60
condition:
  - condition: state
    entity_id: input_boolean.humidity_system_on
    state: "on"
action:
  - service: input_boolean.turn_off
    entity_id: input_boolean.humidifier_on
  - service: input_boolean.turn_on
    entity_id: input_boolean.dehumidifier_on

- alias: "Increase Temperature If Too Low"
trigger:
  platform: numeric_state
  entity_id: sensor.your_temperature_sensor # Replace this with the ID of your temperature
sensor
  below: 18.5 # Triggered when temperature drops below 18.5°C
action:
  service: climate.set_temperature
  target:
    entity_id: climate.your_thermostat # Replace this with the ID of your thermostat
  data:
    temperature: 21
- alias: "Activate Away Mode"
trigger:
  platform: state
  entity_id: input_boolean.heating_away_mode
  to: "on"
action:
  service: input_boolean.turn_off
  entity_id: input_boolean.heating_system_on
- alias: "Close Kinetic Facade on High Temperature"
trigger:
  platform: numeric_state
  entity_id: sensor.kinetic_facade_temperature
  above: 24.5
action:
  service: cover.close_cover
  entity_id: cover.kinetic_facade

- alias: "Close Kinetic Facade on High Light"
trigger:
  platform: numeric_state
  entity_id: sensor.kinetic_facade_light
  above: 2300
action:
  service: cover.close_cover
  entity_id: cover.kinetic_facade

```

```

- alias: "Lower Temperature with Ventilation - Kitchen"
  trigger:
    platform: numeric_state
    entity_id: sensor.kitchen_temperature_sensor
    above: 24.5
  action:
    service: climate.set_temperature
    entity_id: climate.kitchen_ventilation # Replace this with the correct entity for your
kitchen ventilation system
    data:
      temperature: 21

- alias: "Lower Temperature with Ventilation - Dining Area"
  trigger:
    platform: numeric_state
    entity_id: sensor.dining_area_temperature_sensor
    above: 24.5
  action:
    service: climate.set_temperature
    entity_id: climate.dining_area_ventilation # Replace this with the correct entity for
your dining area ventilation system
    data:
      temperature: 21

- alias: "Lower Temperature with Ventilation - Living Room"
  trigger:
    platform: numeric_state
    entity_id: sensor.living_room_temperature_sensor
    above: 24.5
  action:
    service: climate.set_temperature
    entity_id: climate.living_room_ventilation # Replace this with the correct entity for
your living room ventilation system
    data:
      temperature: 21

- alias: "Lower Temperature with Ventilation - Toilet"
  trigger:
    platform: numeric_state
    entity_id: sensor.toilet_temperature_sensor
    above: 23 # Adjust this value to your desired temperature
  action:
    service: climate.set_temperature
    entity_id: climate.toilet_ventilation # Replace this with the correct entity for your
toilet ventilation system
    data:
      temperature: 21

- alias: "Lock All Doors on Intruder Detection"

```

```

trigger:
  platform: state
  entity_id: binary_sensor.intruder_detection_sensor
  to: "on"
action:
  - service: input_boolean.turn_on
    entity_id:
      - input_boolean.garage_door_lock
      - input_boolean.front_door_lock
      - input_boolean.back_door_lock
      - input_boolean.first_floor_door_lock
      - input_boolean.second_floor_door_lock

- alias: "corridor No Motion"
  trigger:
    - platform: state
      entity_id: binary_sensor.motion_sensor_corridor0
      to: "off"
      for:
        minutes: 5
  action:
    - service: light.turn_off
      entity_id: light.corridor1_light

- alias: "corridor1 No Motion"
  trigger:
    - platform: state
      entity_id: binary_sensor.motion_sensor_corridor1
      to: "off"
      for:
        minutes: 5
  action:
    - service: light.turn_off
      entity_id: light.corridor1_light

- alias: "corridor2 No Motion"
  trigger:
    - platform: state
      entity_id: binary_sensor.motion_sensor_corridor2
      to: "off"
      for:
        minutes: 5
  action:
    - service: light.turn_off
      entity_id: light.corridor2_light

- alias: "Window Opened Alert"
  trigger:
    - platform: state
      entity_id: binary_sensor.window_kitchen
      to: "on"

```

```

- platform: state
  entity_id: binary_sensor.window_bedroom
  to: "on"
- platform: state
  entity_id: binary_sensor.window_guestroom
  to: "on"
- platform: state
  entity_id: binary_sensor.window_livingroom
  to: "on"
- platform: state
  entity_id: binary_sensor.window_workingspace
  to: "on"
- platform: state
  entity_id: binary_sensor.window_bedroom
  to: "on"

action:
  - service: notify.notify # Replace with your preferred notification service
    data:
      message: "A window has been opened."

- alias: "Adjust AC Based on Temperature"
  trigger:
    - platform: numeric_state
      entity_id: sensor.living_room_temperature
      above: 24 # Adjust the temperature threshold as needed
  action:
    - service: climate.set_temperature
      entity_id: climate.living_room_ac
      data:
        temperature: 21 # Set your desired temperature

# Motion Sensors
binary_sensor:
  - platform: template
    sensors:
      motion_sensor_kitchen:
        friendly_name: "Kitchen Motion Sensor"
        device_class: motion
        value_template: "{ is_state('input_boolean.motion_kitchen', 'on') }"

      motion_sensor_dining_area:
        friendly_name: "Dining Area Motion Sensor"
        device_class: motion
        value_template: "{ is_state('input_boolean.motion_dining_area', 'on') }"

      motion_sensor1_living_room:
        friendly_name: "Living Room Motion Sensor"
        device_class: motion

```

```
    value_template: "{ is_state('input_boolean.motion_living_room', 'on') }}"

motion_sensor2_living_room:
  friendly_name: "Living Room Motion Sensor"
  device_class: motion
  value_template: "{ is_state('input_boolean.motion_living_room', 'on') }}"

motion_sensor_toilet:
  friendly_name: "Toilet Motion Sensor"
  device_class: motion
  value_template: "{ is_state('input_boolean.motion_toilet', 'on') }}"

motion_sensor1_garage:
  friendly_name: "Garage Motion Sensor"
  device_class: motion
  value_template: "{ is_state('input_boolean.motion_garage', 'on') }}"

motion_sensor2_garage:
  friendly_name: "Garage Motion Sensor"
  device_class: motion
  value_template: "{ is_state('input_boolean.motion_garage', 'on') }}"

motion_sensor1_corridor0:
  friendly_name: "Corridor 0 Motion Sensor"
  device_class: motion
  value_template: "{ is_state('input_boolean.motion_corridor1', 'on') }}"

motion_sensor2_corridor0:
  friendly_name: "Corridor 0 Motion Sensor"
  device_class: motion
  value_template: "{ is_state('input_boolean.motion_corridor1', 'on') }}"

motion_sensor_bathroom:
  friendly_name: "Bathroom Motion Sensor"
  device_class: motion
  value_template: "{ is_state('input_boolean.motion_bathroom', 'on') }}"

motion_sensor_corridor1:
  friendly_name: "Corridor 1 Motion Sensor"
  device_class: motion
  value_template: "{ is_state('input_boolean.motion_corridor1', 'on') }}"

motion_sensor_bedroom:
  friendly_name: "Bedroom Motion Sensor"
  device_class: motion
  value_template: "{ is_state('input_boolean.motion_bedroom', 'on') }}"

motion_sensor1_working_space:
  friendly_name: "Working Space Motion Sensor"
```

```

    device_class: motion
    value_template: "{ is_state('input_boolean.motion_working_space', 'on') }{"

motion_sensor2_working_space:
    friendly_name: "Working Space Motion Sensor"
    device_class: motion
    value_template: "{ is_state('input_boolean.motion_working_space', 'on') }{"

motion_sensor_guest_room:
    friendly_name: "Guest Room Motion Sensor"
    device_class: motion
    value_template: "{ is_state('input_boolean.motion_guest_room', 'on') }{"

motion_sensor_corridor2:
    friendly_name: "Corridor 2 Motion Sensor"
    device_class: motion
    value_template: "{ is_state('input_boolean.motion_corridor2', 'on') }{"

## Temperature Control and Humidity Control combined under input_number
input_number:
    ground_floor_temperature:
        name: Ground Floor Temperature
        min: 16
        max: 30
        step: 0.5
    kitchen_temperature:
        name: Kitchen Temperature
        min: 16
        max: 30
        step: 0.5
    dining_area_temperature:
        name: Dining Area Temperature
        min: 16
        max: 30
        step: 0.5
    living_room_temperature:
        name: Living Room Temperature
        min: 16
        max: 30
        step: 0.5
    toilet_temperature:
        name: Toilet Temperature
        min: 16
        max: 30
        step: 0.5
    garage_temperature:
        name: Garage Temperature
        min: 16
        max: 30

```

```

    step: 0.5
corridor1_temperature:
  name: Corridor 1 Temperature
  min: 16
  max: 30
  step: 0.5
bathroom_temperature:
  name: Bathroom Temperature
  min: 16
  max: 30
  step: 0.5
bedroom_temperature:
  name: Bedroom Temperature
  min: 16
  max: 30
  step: 0.5
working_space_temperature:
  name: Working Space Temperature
  min: 16
  max: 30
  step: 0.5
guest_room_temperature:
  name: Guest Room Temperature
  min: 16
  max: 30
  step: 0.5
corridor2_temperature:
  name: Corridor 2 Temperature
  min: 16
  max: 30
  step: 0.5

# Temperature Display Sensors
sensor:
  - platform: template
    sensors:
      air_purity:
        friendly_name: "Air Purity"
        value_template: >-
          {% if states('sensor.some_particle_detector') | float > 50%/%}
            not clean
          {%else%}
            clean
          {%endif%}

      room_humidity:
        friendly_name: "Room Humidity"
        unit_of_measurement: "%"
        value_template: "{ states('sensor.room_humidity_raw') | float }"

```

```

kinetic_facade_light_intensity:
  friendly_name: "Kinetic Facade Light Intensity"
  unit_of_measurement: "lux"
  value_template: "{ states('sensor.kinetic_facade_light_intensity_raw') | float }"
kinetic_facade_temperature:
  friendly_name: "Kinetic Facade Temperature"
  unit_of_measurement: "°C"
  value_template: "{ states('sensor.kinetic_facade_temperature_raw') | float }"
ground_floor_temperature_sensor:
  friendly_name: "Ground Floor Temperature Sensor"
  unit_of_measurement: "°C"
  value_template: "{ states('input_number.ground_floor_temperature') }"
kitchen_temperature_sensor:
  friendly_name: "Kitchen Temperature Sensor"
  unit_of_measurement: "°C"
  value_template: "{ states('input_number.kitchen_temperature') }"
dining_area_temperature_sensor:
  friendly_name: "Dining Area Temperature Sensor"
  unit_of_measurement: "°C"
  value_template: "{ states('input_number.dining_area_temperature') }"
living_room_temperature_sensor:
  friendly_name: "Living Room Temperature Sensor"
  unit_of_measurement: "°C"
  value_template: "{ states('input_number.living_room_temperature') }"
toilet_temperature_sensor:
  friendly_name: "Toilet Temperature Sensor"
  unit_of_measurement: "°C"
  value_template: "{ states('input_number.toilet_temperature') }"
garage_temperature_sensor:
  friendly_name: "Garage Temperature Sensor"
  unit_of_measurement: "°C"
  value_template: "{ states('input_number.garage_temperature') }"
corridor1_temperature_sensor:
  friendly_name: "Corridor 1 Temperature Sensor"
  unit_of_measurement: "°C"
  value_template: "{ states('input_number.corridor1_temperature') }"
bathroom_temperature_sensor:
  friendly_name: "Bathroom Temperature Sensor"
  unit_of_measurement: "°C"
  value_template: "{ states('input_number.bathroom_temperature') }"
bedroom_temperature_sensor:
  friendly_name: "Bedroom Temperature Sensor"
  unit_of_measurement: "°C"
  value_template: "{ states('input_number.bedroom_temperature') }"
working_space_temperature_sensor:
  friendly_name: "Working Space Temperature Sensor"
  unit_of_measurement: "°C"
  value_template: "{ states('input_number.working_space_temperature') }"
guest_room_temperature_sensor:

```



```
    friendly_name: "Guest Room Temperature Sensor"
    unit_of_measurement: "°C"
    value_template: "{ states('input_number.guest_room_temperature') }"
corridor2_temperature_sensor:
    friendly_name: "Corridor 2 Temperature Sensor"
    unit_of_measurement: "°C"
    value_template: "{ states('input_number.corridor2_temperature') }"

input_boolean:
  humidity_system_on:
    name: "Humidity System On"
    initial: off
    icon: mdi:water-percent

  dehumidifier_on:
    name: "Dehumidifier On"
    initial: off
    icon: mdi:air-humidifier-off

  humidifier_on:
    name: "Humidifier On"
    initial: off
    icon: mdi:air-humidifier

  kinetic_facade_open:
    name: "Kinetic Facade Open"
    initial: on

  kitchen_ventilation:
    name: Kitchen Ventilation System
    initial: off

  dining_area_ventilation:
    name: Dining Area Ventilation System
    initial: off

  living_room_ventilation:
    name: Living Room Ventilation System
    initial: off

  toilet_ventilation:
    name: Toilet Ventilation System
    initial: off

  garage_ventilation:
    name: Garage Ventilation System
    initial: off

  corridor1_ventilation:
    name: Corridor 1 Ventilation System
    initial: off

  bathroom_ventilation:
    name: Bathroom Ventilation System
    initial: off

  bedroom_ventilation:
```

```
    name: Bedroom Ventilation System
    initial: off
working_space_ventilation:
    name: Working Space Ventilation System
    initial: off
guest_room_ventilation:
    name: Guest Room Ventilation System
    initial: off
corridor2_ventilation:
    name: Corridor 2 Ventilation System
    initial: off
```

```
kitchen_light:
    name: Kitchen Light
    initial: off
dining_area_light:
    name: Dining Area Light
    initial: off
living_room_light:
    name: Living Room Light
    initial: off
```

```
toilet_light:
    name: Toilet Light
    initial: off
```

```
garage_light:
    name: Garage Light
    initial: off
```

```
corridor0_light:
    name: Corridor 0 Light
```

```
corridor1_light:
    name: Corridor 1 Light
    initial: off
```

```
bathroom_light:
    name: Bathroom Light
    initial: off
```

```
bedroom_light:
    name: Bedroom Light
    initial: off
```

```
working_space_light:
    name: Working Space Light
    initial: off
```

```
guest_room_light:
    name: Guest Room Light
    initial: off
```

```
corridor2_light:
    name: Corridor 2 Light
    initial: off
```

```
kitchen_smoke_detector:
```

```
    name: Kitchen smoke_detector
    initial: off
living_room_smoke_detector:
    name: Living Room smoke_detector
    initial: off
garage_smoke_detector:
    name: Garage smoke_detector
    initial: off
corridor0_smoke_detector:
    name: Corridor 0 smoke_detector
corridor1_smoke_detector:
    name: Corridor 1 smoke_detector
    initial: off
bedroom_smoke_detector:
    name: Bedroom smoke_detector
    initial: off
working_space_smoke_detector:
    name: Working Space smoke_detector
    initial: off
guest_room_smoke_detector:
    name: Guest Room smoke_detector
    initial: off
corridor2_smoke_detector:
    name: Corridor 2 smoke_detector
    initial: off
# Motion Triggers
motion_ground_floor:
    name: Ground Floor Motion Trigger
    initial: off
motion_kitchen:
    name: Kitchen Motion Trigger
    initial: off
motion_dining_area:
    name: Dining Area Motion Trigger
    initial: off
motion_living_room:
    name: Living Room Motion Trigger
    initial: off
motion_toilet:
    name: Toilet Motion Trigger
    initial: off
motion_garage:
    name: Garage Motion Trigger
    initial: off
motion_corridor1:
    name: Corridor 1 Motion Trigger
    initial: off
motion_corridor0:
    name: Corridor 0 Motion Trigger
```

```
    initial: off
motion_bathroom:
  name: Bathroom Motion Trigger
  initial: off
motion_bedroom:
  name: Bedroom Motion Trigger
  initial: off
motion_working_space:
  name: Working Space Motion Trigger
  initial: off
motion_guest_room:
  name: Guest Room Motion Trigger
  initial: off
motion_corridor2:
  name: Corridor 2 Motion Trigger
  initial: off
# Window State
window_kitchen:
  name: Kitchen Window
  initial: off
window_living_room:
  name: Living Room Window
  initial: off
window_bathroom:
  name: Bathroom Window
  initial: off
window_bedroom:
  name: Bedroom Window
  initial: off
window_working_space:
  name: Working Space Window
  initial: off
window_guest1_room:
  name: Guest Room Window
  initial: off
window_guest2_room:
  name: Guest Room Window
  initial: off
window_corridor2:
  name: Corridor 2 Window
  initial: off
# Shading System State
indoor_shade_kitchen:
  name: Kitchen indoor_shade
  initial: off
indoor_shade_living_room:
  name: Living Room indoor_shade
  initial: off
indoor_shade_bedroom:
```

```
    name: Bedroom indoor_shade
    initial: off
indoor_shade_guest_room:
    name: Guest Room indoor_shade
    initial: off
# Air Conditioning Control
ac_living_room:
    name: Living Room Air Conditioner
    initial: off
ac_guest_room:
    name: Guest Room Air Conditioner
    initial: off
ac_workingspace_room:
    name: workingspace Air Conditioner
    initial: off
# lock control
garage_door_lock:
    name: Garage Door Lock
    initial: off

livingroom_door_lock:
    name: living room Door Lock
    initial: off

front_door_lock:
    name: Front Door Lock
    initial: off

back_door_lock:
    name: Back Door Lock
    initial: off

workingspace_door_lock:
    name: working space Door Lock
    initial: off

guestroom_door_lock:
    name: guest room Door Lock
    initial: off

heating_system_on:
    name: "Heating System"
    initial: off
heating_boost_mode:
    name: "Heating Boost Mode"
    initial: off
heating_away_mode:
    name: "Away Mode"
    initial: off
```

Appendix F: Prototype

Prototype and the place of the experiment:

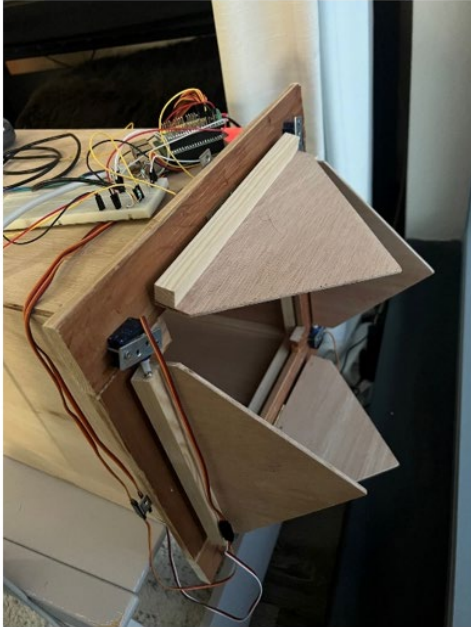

Schematic overview of prototype positioning in relation to the Sunpath using Ladybug Tools:
selection of Ypenburg due to unavailability of Delft's EPW File:

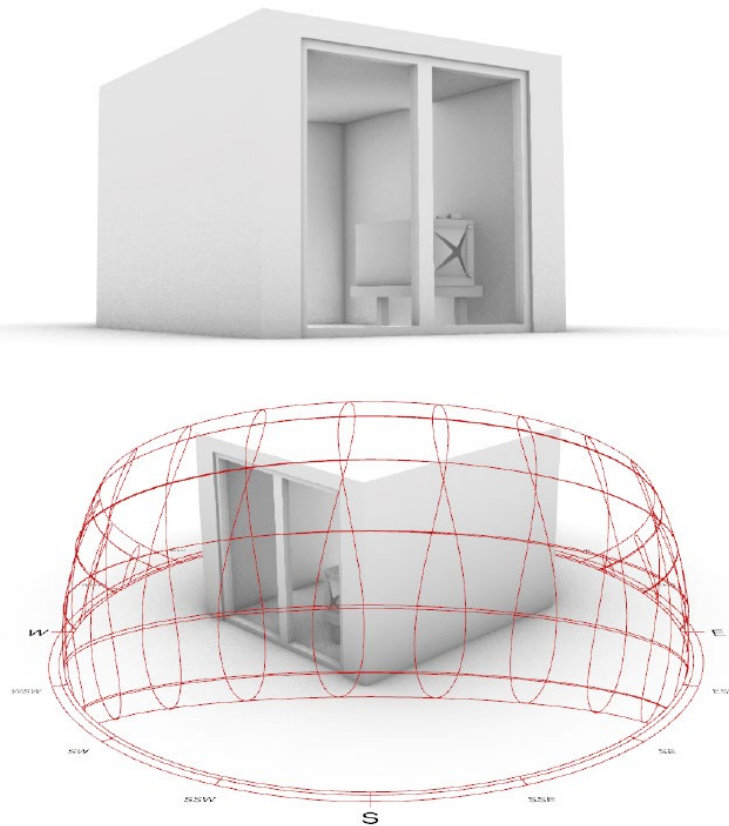

city: Ypenburg

Installation Raspberry Pi:

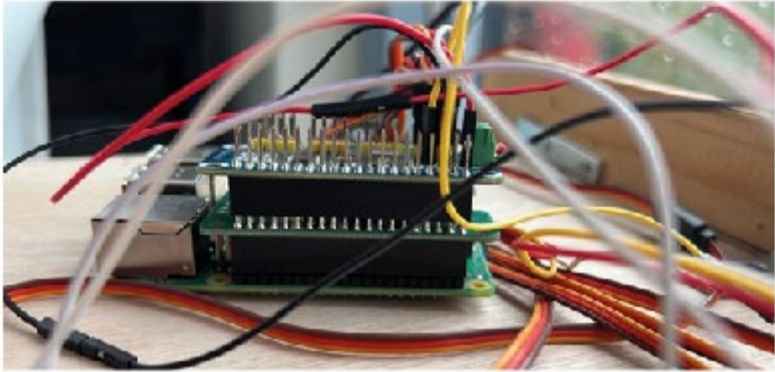
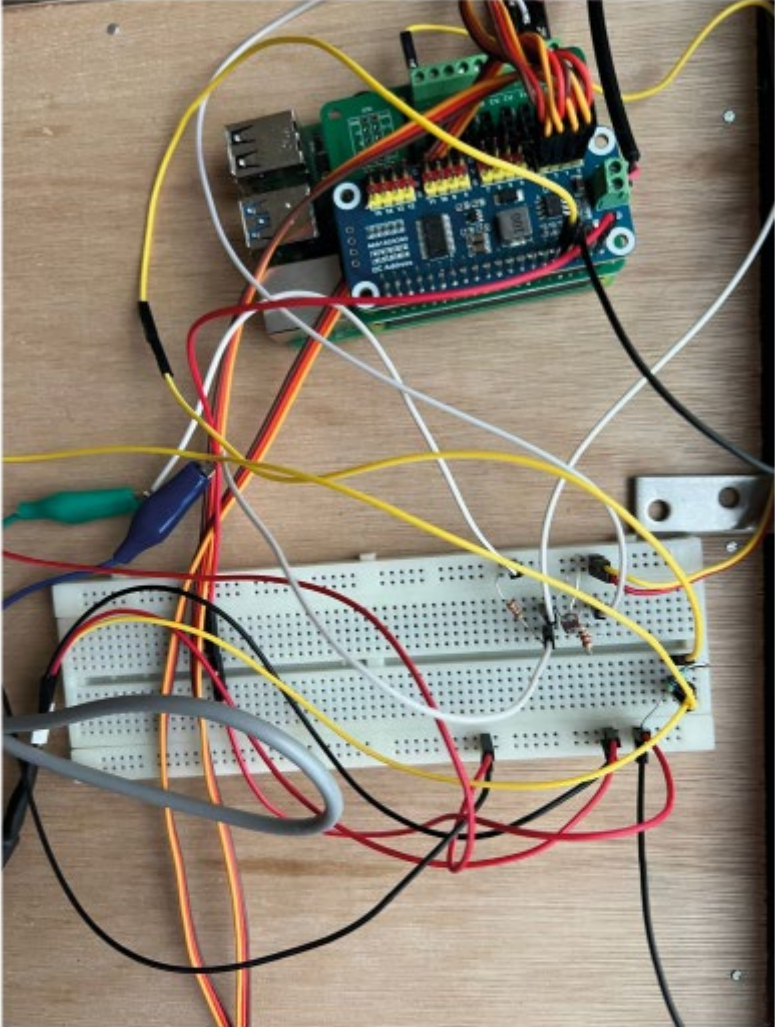

Technical setup:

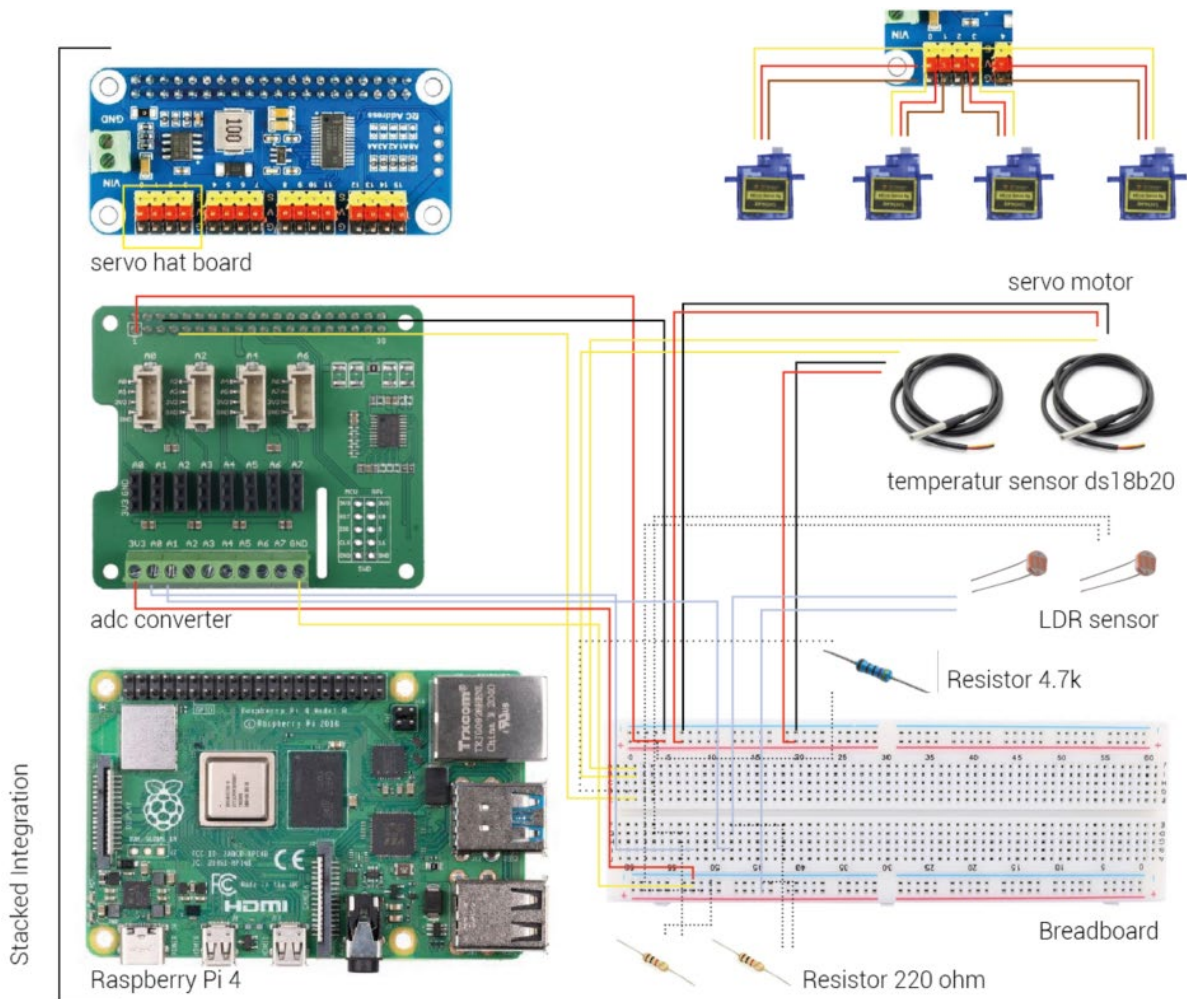

Appendix G: Prototype Raspberry Pi code – Experiment 1

```
import time

import mysql.connector
import seaborn as sns
import matplotlib.pyplot as plt
import pandas as pd
import logging

from grove.adc_8chan_12bit import Pi_hat_adc
from adafruit_servokit import ServoKit
from datetime import datetime

# Logging setup
logging.basicConfig(filename='error.log', level=logging.ERROR)

# Initialize PCA9685 and set the frequency.
kit = ServoKit(channels=16)

class GroveGL5516:
    def __init__(self, channel):
        self.channel = channel
        self.adc = Pi_hat_adc()

    def get_lux(self):
        try:
            value = self.adc.get_nchan_adc_raw_data(self.channel)
            # Adjust the formula as per your calibration
            lux = (4095 - value) / 4095 * 20000
            return lux
        except Exception as e:
            logging.error(f"Error reading lux value: {e}")
            return None

def calculate_angle(lux_outside):
    # Adjust the angle based on the outside lux
    if lux_outside <= 0:
        return 180 # Fully open
    elif lux_outside >= 4095:
        return 0 # Fully closed
    else:
        return (1 - (lux_outside / 4095)) * 180

def read_temperature(sensor_id):
    try:
        with open(f"/sys/bus/w1/devices/{sensor_id}/w1_slave", "r") as f:
            lines = f.readlines()
            if lines[0].strip()[-3:] == "YES":
```

```

        temp_string = lines[1].split("=")[-1]
        temp_c = float(temp_string) / 1000.0
        return temp_c
    else:
        return None
except Exception as e:
    logging.error(f"Error reading temperature from {sensor_id}: {e}")
    return None

# MySQL Connection setup
try:
    db = mysql.connector.connect(
        host="localhost",
        user="root",
        password="Bouwkunde",
        database="Kinetic_facade"
    )
    cursor = db.cursor()
except mysql.connector.Error as err:
    logging.error(f"Database connection failed: {err}")

# Initialize LDR
ldr_outside = GroveGL5516(0)
ldr_inside = GroveGL5516(1)

# Main Loop
while True:
    try:
        lux_outside = ldr_outside.get_lux()
        lux_inside = ldr_inside.get_lux()
        temp_sensor1 = read_temperature("28-0723301e60ec")
        temp_sensor2 = read_temperature("28-3c59f64833a2")
        angle = calculate_angle(lux_outside)

        # Print and log data
        print(f"-----")
        print(f"Outside Lux: {lux_outside}")
        print(f"Inside Lux: {lux_inside}")
        print(f"Temperature Sensor 1: {temp_sensor1}°C")
        print(f"Temperature Sensor 2: {temp_sensor2}°C")
        print(f"Calculated angle: {angle}")

        # Set angle for all 4 servos
        for i in range(4):
            kit.servo[i].angle = angle
        print("Servos moved")

        # Insert data into MySQL
        timestamp = datetime.now().strftime('%Y-%m-%d %H:%M:%S')

```

```

try:
    cursor.execute("INSERT INTO sensor_data(timestamp, angle, lux_inside,
lux_outside, temp_sensor1, temp_sensor2) VALUES (%s, %s, %s, %s, %s, %s)",
                    (timestamp, angle, lux_inside, lux_outside,
temp_sensor1, temp_sensor2))
    db.commit()
except mysql.connector.Error as err:
    logging.error(f"Error in database operation: {err}")

# Plotting
try:
    cursor.execute("SELECT lux_outside, angle, temp_sensor1, temp_sensor2
FROM sensor_data ORDER BY timestamp DESC LIMIT 100")
    data = cursor.fetchall()
    df = pd.DataFrame(data, columns=['Lux', 'Angle', 'Temp1', 'Temp2'])
    sns.lineplot(data=df, x='Lux', y='Temp1')
    sns.lineplot(data=df, x='Lux', y='Temp2')
    plt.savefig("plot.png")
    plt.close()
except Exception as e:
    logging.error(f"Error in plotting data: {e}")

print("Sleeping")
time.sleep(5)

except Exception as e:
    logging.error(f"An error occurred in the main loop: {e}")
time.sleep(5)

```

Appendix H: Prototype Raspberry Pi code – Experiment 2

```
import time
import mysql.connector
import seaborn as sns
import matplotlib.pyplot as plt
import pandas as pd
import logging
from grove.adc_8chan_12bit import Pi_hat_adc
from adafruit_servokit import ServoKit
from datetime import datetime

# Logging setup
logging.basicConfig(filename='error.log', level=logging.ERROR)

# Initialize PCA9685 and set the frequency.
kit = ServoKit(channels=16)

class GroveGL5516:
    def __init__(self, channel):
        self.channel = channel
        self.adc = Pi_hat_adc()

    def get_lux(self):
        try:
            value = self.adc.get_nchan_adc_raw_data(self.channel)
            return adc_value_to_lux(value)
        except Exception as e:
            logging.error(f"Error reading lux value: {e}")
            return None

def adc_value_to_lux(adc_value):
    max_lux = 20000 # Maximum lux value when ADC value is 0
    max_adc_value = 4095 # Maximum ADC value for a 12-bit ADC
    lux = max_lux - (adc_value / max_adc_value) * max_lux
    return lux

def calculate_angle_change(lux_inside, current_angle):
    TARGET_LUX_INSIDE = 300 # Desired inside lux level
    adjustment_factor = 0.1 # Sensitivity of the angle adjustment
    max_angle_change_per_iteration = 50 # Maximum angle change per iteration

    # Calculate the difference from the target lux level
    lux_difference = TARGET_LUX_INSIDE - lux_inside

    # Calculate angle adjustment based on the difference
    angle_change = lux_difference * adjustment_factor

    # Limit the change to avoid abrupt movements
```

```

        angle_change = max(-max_angle_change_per_iteration,
min(max_angle_change_per_iteration, angle_change))

    # Calculate new angle and ensure it's within 0-180 degrees
    new_angle = current_angle + angle_change
    new_angle = max(0, min(180, new_angle))

    return new_angle

def read_temperature(sensor_id):
    try:
        with open(f"/sys/bus/w1/devices/{sensor_id}/w1_slave", "r") as f:
            lines = f.readlines()
            if lines[0].strip()[-3:] == "YES":
                temp_string = lines[1].split("=")[-1]
                temp_c = float(temp_string) / 1000.0
                return temp_c
            else:
                return None
    except Exception as e:
        logging.error(f"Error reading temperature from {sensor_id}: {e}")
        return None

# MySQL Connection
try:
    db = mysql.connector.connect(
        host="localhost",
        user="root",
        password="Bouwkunde",
        database="Kinetic_facade"
    )
    cursor = db.cursor()
except mysql.connector.Error as err:
    logging.error(f"Database connection failed: {err}")

# Initialize LDR
ldr_outside = GroveGL5516(0)
ldr_inside = GroveGL5516(1)

current_angle = 40 # Initialize the current angle

# Main Loop
while True:
    try:
        lux_outside = ldr_outside.get_lux()
        lux_inside = ldr_inside.get_lux()
        temp_sensor1 = read_temperature("28-0723301e60ec")
        temp_sensor2 = read_temperature("28-3c59f64833a2")

```

```

    temp_sensor3 = read_temperature("28-00000017a2ec") # Reading from the
third sensor
    current_angle = calculate_angle_change(lux_inside, current_angle)

    # Print and log data
    print(f"-----")
    print(f"Inside Lux: {lux_inside}")
    print(f"Outside Lux: {lux_outside}")
    print(f"Temperature Sensor 1: {temp_sensor1}°C")
    print(f"Temperature Sensor 2: {temp_sensor2}°C")
    print(f"Temperature Sensor 3: {temp_sensor3}°C") # Logging the third
sensor
    print(f"Calculated angle: {current_angle}")

    for i in range(4):
        kit.servo[i].angle = current_angle
    print("Servos moved")

    timestamp = datetime.now().strftime('%Y-%m-%d %H:%M:%S')
    try:
        cursor.execute("INSERT INTO sensor_data(timestamp, angle, lux_inside,
lux_outside, temp_sensor1, temp_sensor2, temp_sensor3) VALUES (%s, %s, %s, %s,
%s, %s, %s)",
                        (timestamp, current_angle, lux_inside, lux_outside,
temp_sensor1, temp_sensor2, temp_sensor3)) # Inserting third sensor data
        db.commit()
    except mysql.connector.Error as err:
        print(f"Error in database operation: {err}")
    try:
        cursor.execute("SELECT lux_outside, angle, temp_sensor1,
temp_sensor2, temp_sensor3 FROM sensor_data ORDER BY timestamp DESC LIMIT 100")
        data = cursor.fetchall()
        df = pd.DataFrame(data, columns=['Lux', 'Angle', 'Temp1', 'Temp2',
'Temp3'])
        sns.lineplot(data=df, x='Lux', y='Temp1')
        sns.lineplot(data=df, x='Lux', y='Temp2')
        sns.lineplot(data=df, x='Lux', y='Temp3') # Plotting the third
sensor data
        plt.savefig("plot.png")
        plt.close()
    except Exception as e:
        logging.error(f"Error in plotting data: {e}")

    print("Sleeping")
    time.sleep(5)

except Exception as e:
    logging.error(f"An error occurred in the main loop: {e}")
    time.sleep(5)

```