

# Hello World!

Dear Digital Guest,

I'm glad you made it.

The schedule:

13:45	Presentation
14:15	Plenary Q&A
14:30	Private Discussion
14:50	Committee verdict

If you have any questions, please ask them during the Q&A-session at the end, by unmuting or via the chat. If anything is unclear, invisible or inaudible during the presentation please let my tech support know in the chat.







**Future proofing the  
Royal Delft approach  
to Mold Making**

Thesis Presentation  
Yannic Heesackers  
8-September-2021

*“Analyze the mold making process and transform it into the future Royal Delft approach to mold making,*



*“Analyze the mold making process and transform it into the future Royal Delft approach to mold making,*

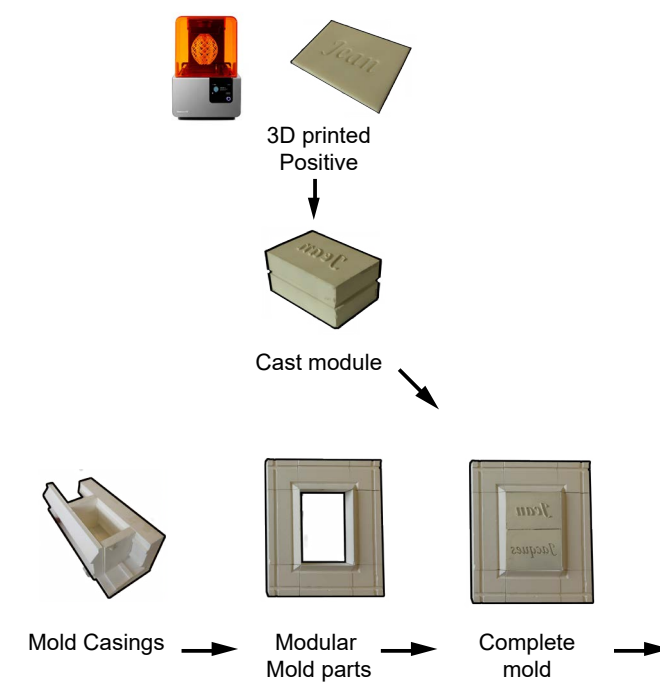

Production approach



Showcase product



# This presentation

1. Context
2. Design Brief
3. Ideation
4. Implementation



# This presentation

1. Context
2. Design Brief
3. Ideation
4. Implementation

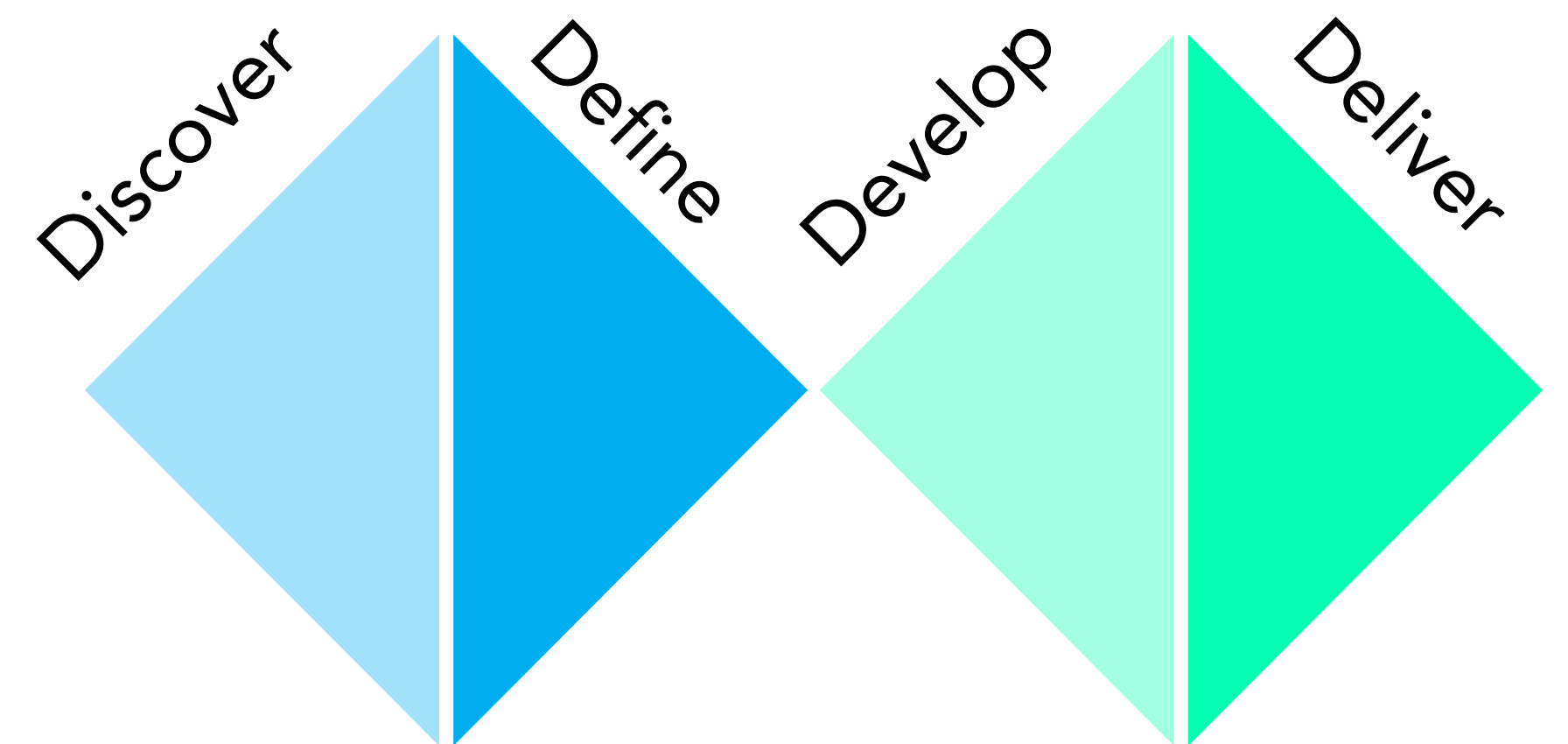



# 1. Context

Discover





# This is Delft Blue?





# This is Delft Blue?





# This is Delft Blue?





# Delft Blue or Royal Delft



Delft Blue visual style



Delft Blue Ceramics





# Royal Delft Ceramics



# Collection



Traditional



Modern



# Decoration



Hand Painted



Transfer



# Collaborations



 **SCHIFFMÜCHER  
TATTOO  
HERITAGE**



**m o o o i**



**Supreme**



# Customwork





A photograph showing a ceramic production process. In the foreground, a large, light-colored ceramic mold is visible, featuring a central circular opening. The mold is surrounded by other similar ceramic components, some of which are stacked in the background. The scene is set in a factory or workshop environment. A semi-transparent blue banner is overlaid at the bottom of the image, containing the text "Ceramic Production Process".

# Ceramic Production Process



# Production Process

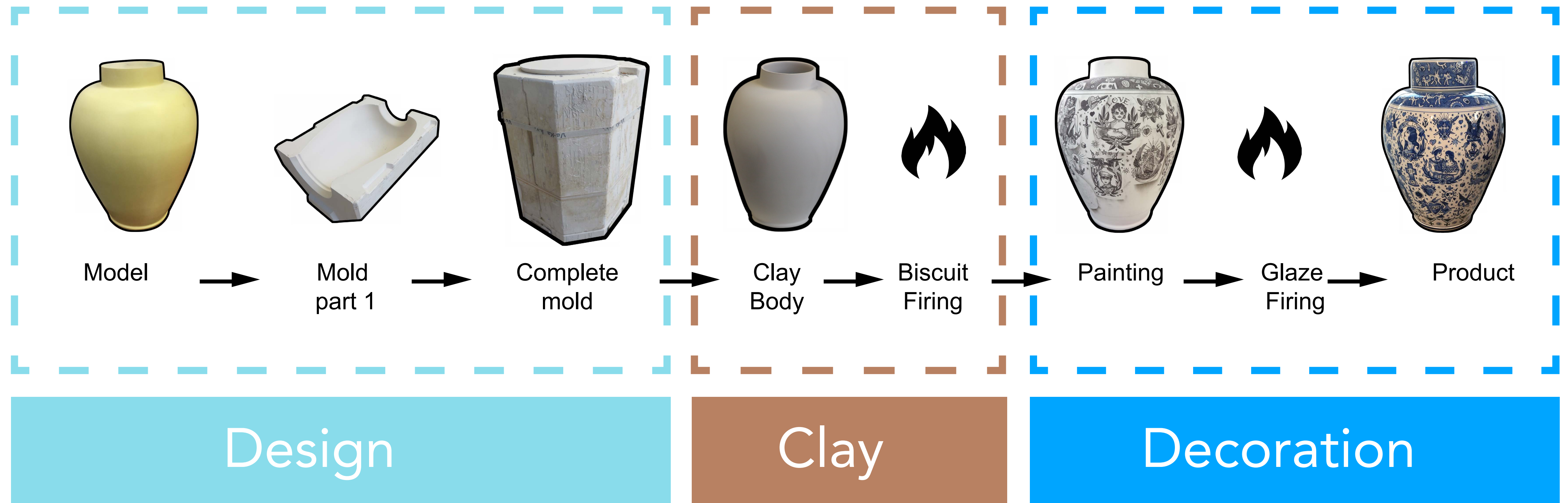







# Mold Making

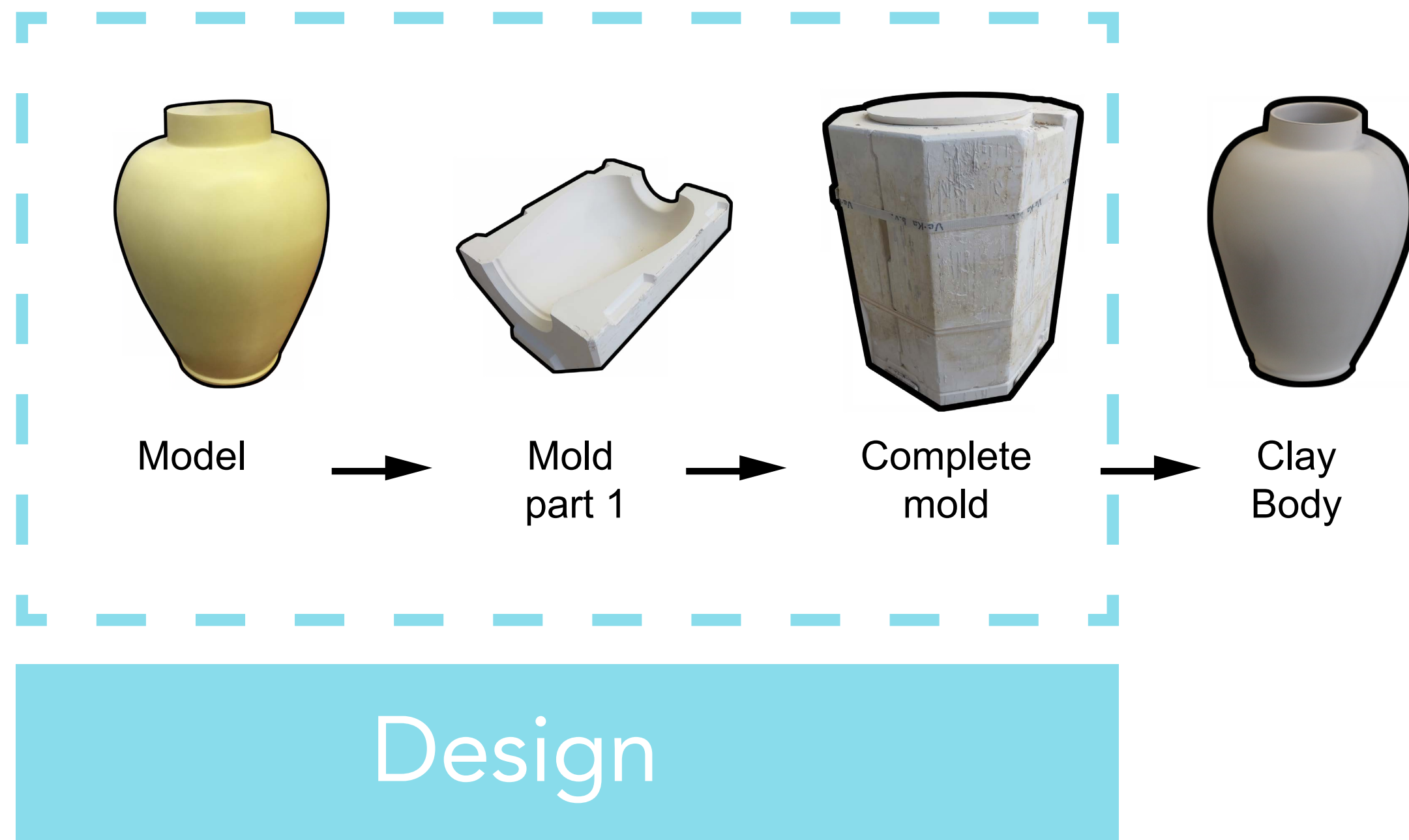



# Mold Making 101 - Flat Shapes





# Mold Making 101 - Flat Shapes

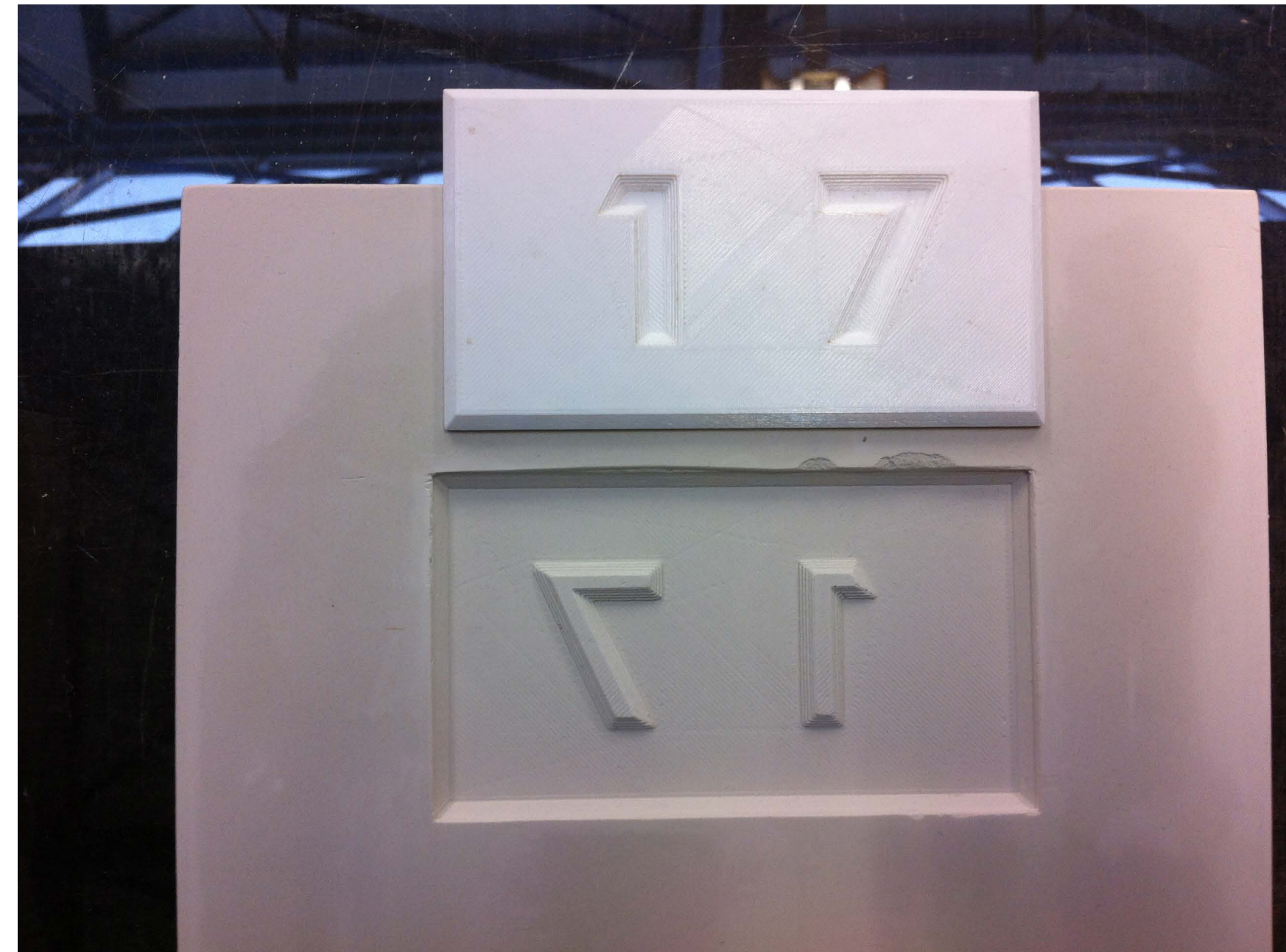



# Mold Making 101 - Flat Shapes





# Mold Making 201 - Complex shapes





# Mold Making 201 - Complex shapes

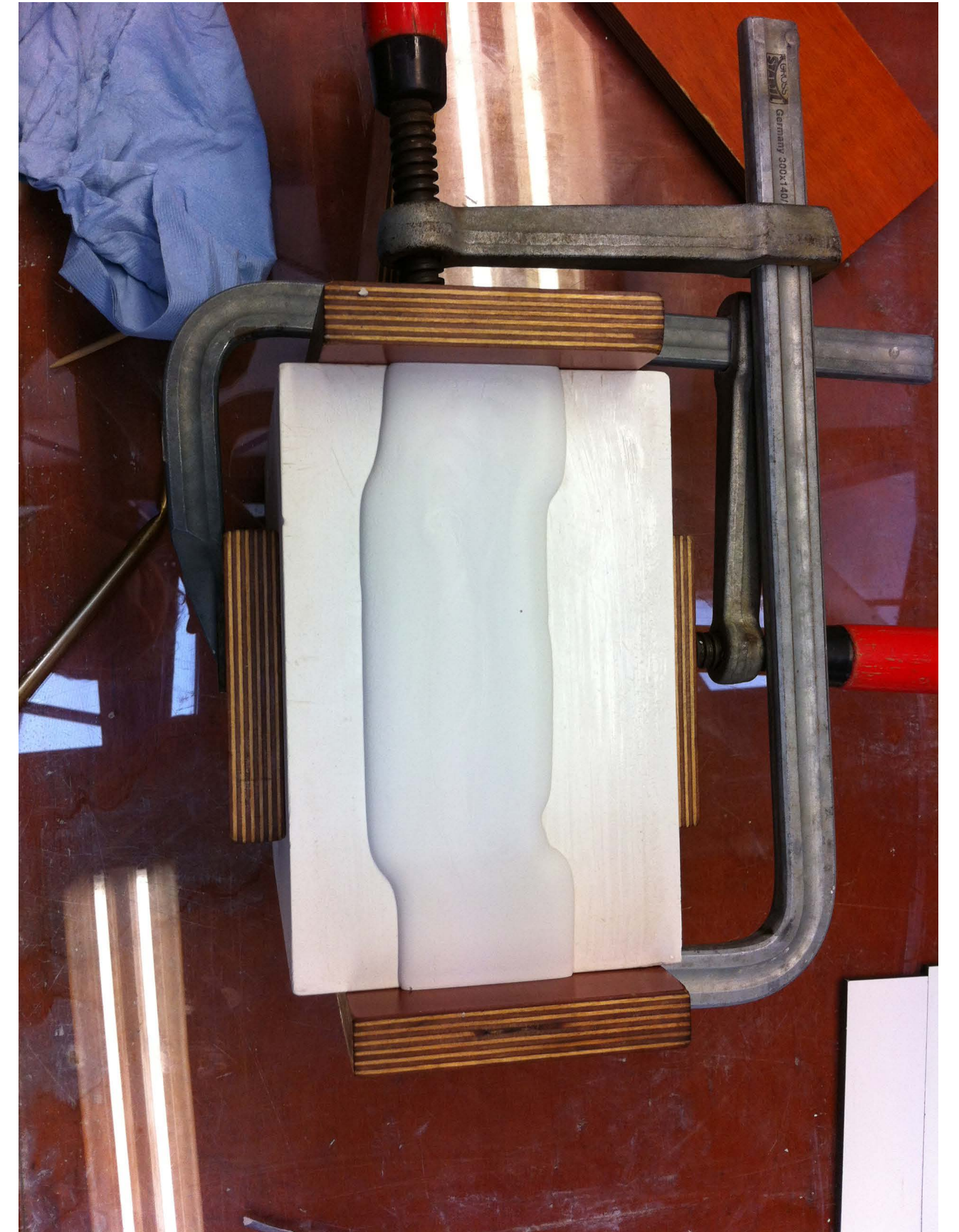
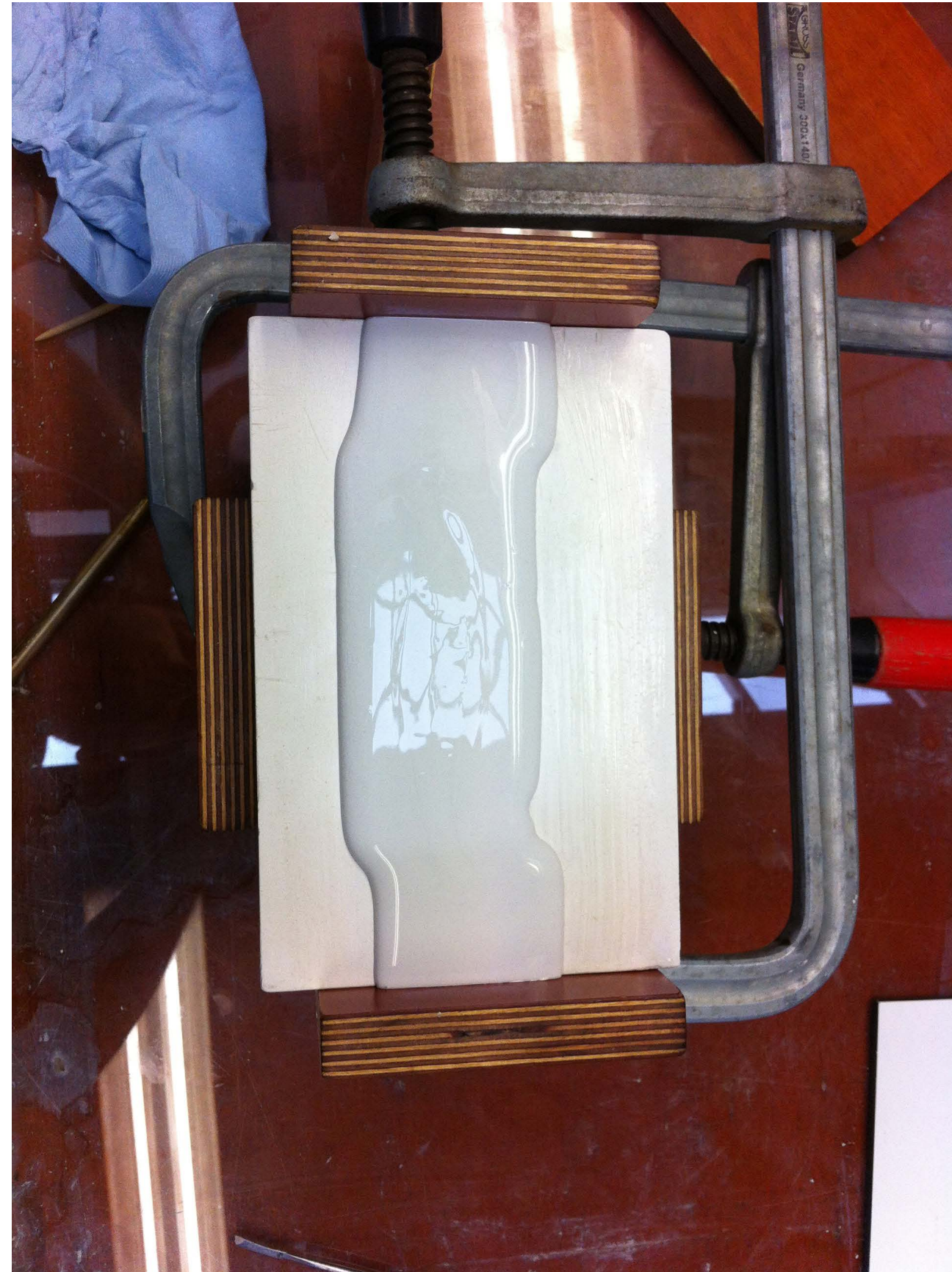



# Mold Making 201 - Complex shapes

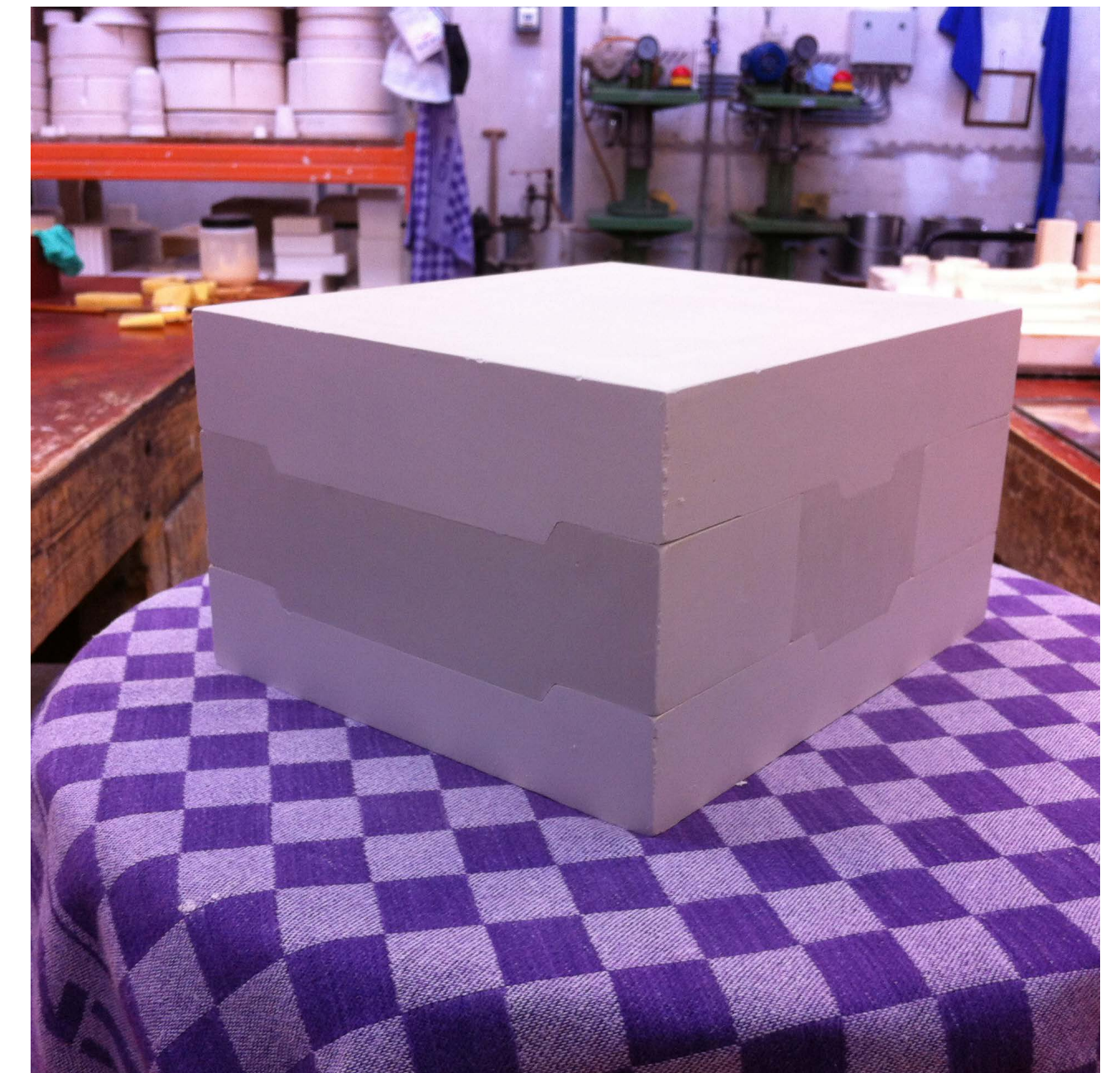
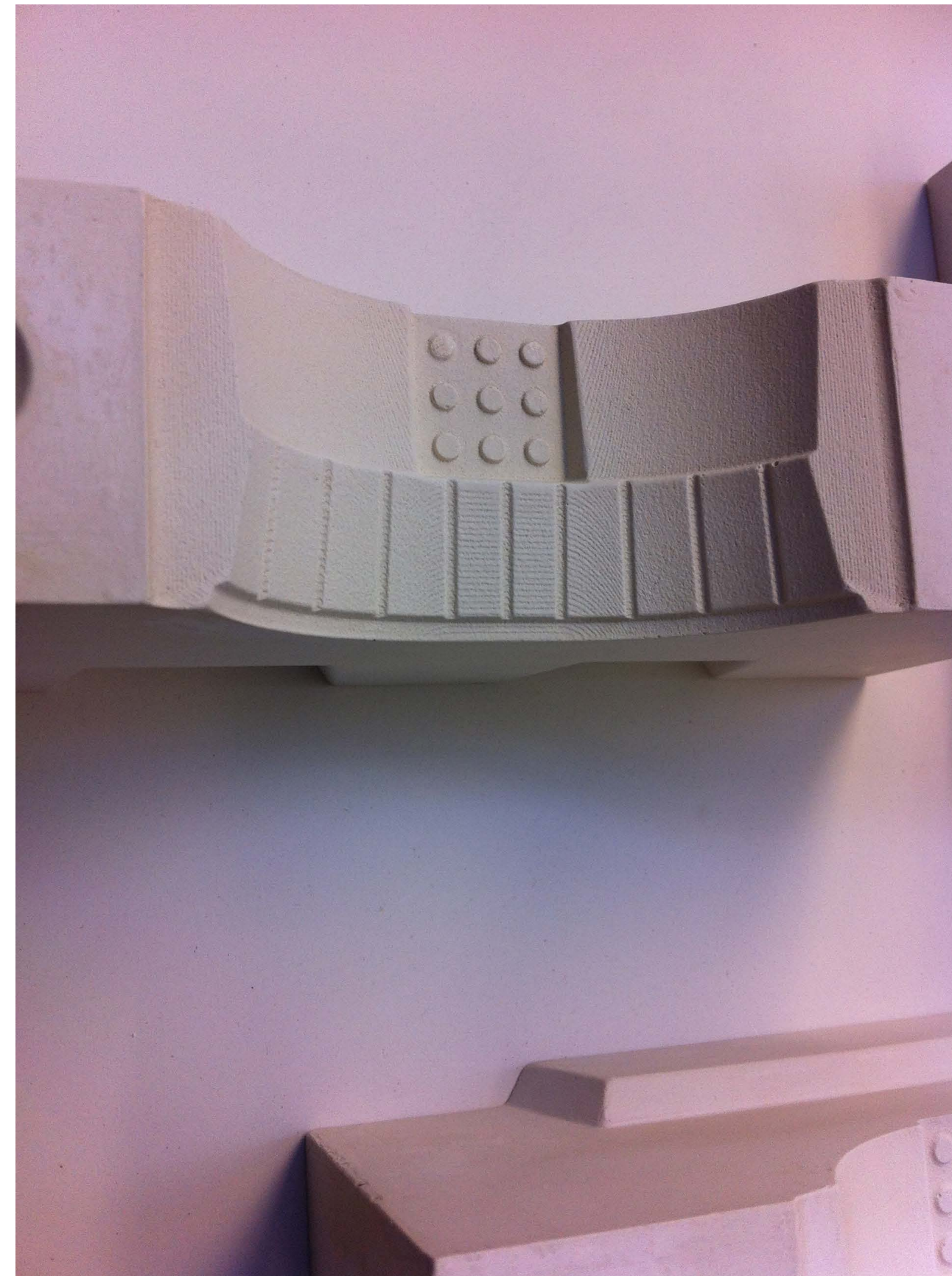
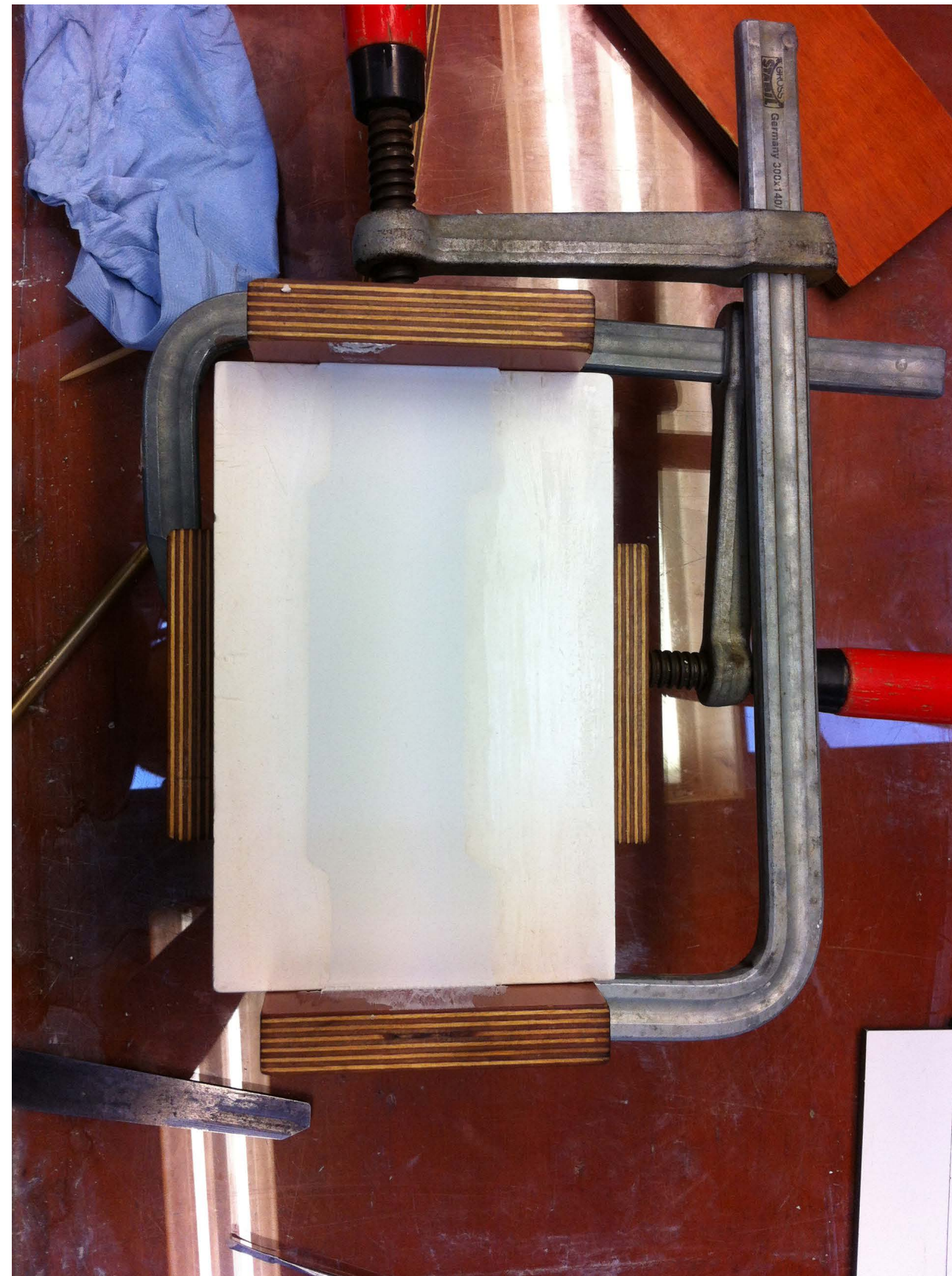



# Mold Making - Difficult Job

Clay release  
Clay structure  
Split lines  
Surface quality  
Absorption  
Breaking  
Leaking





# Mold Making - Dilemma's

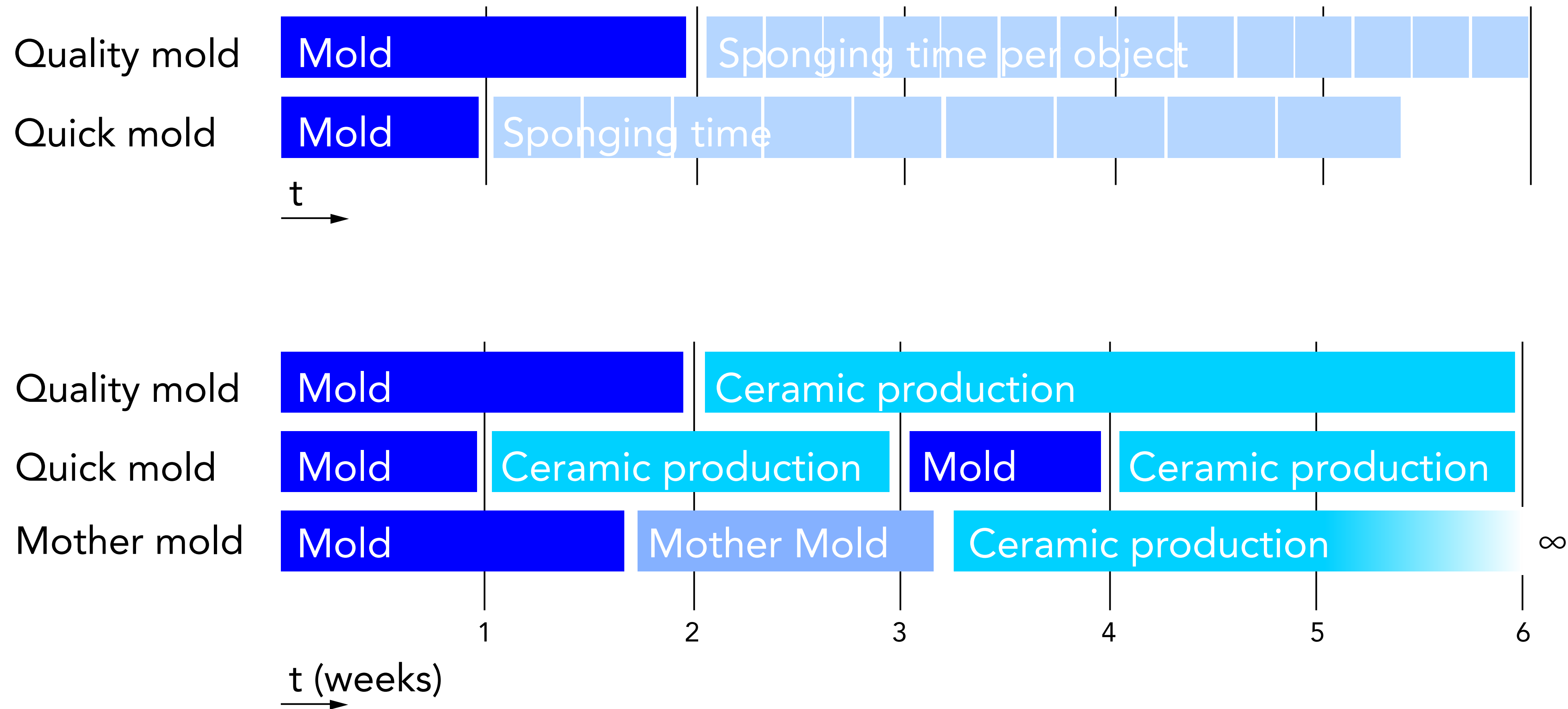



# 2. Design Brief





# Problem Statement

New product development is:



1. Time, labour and cost intensive

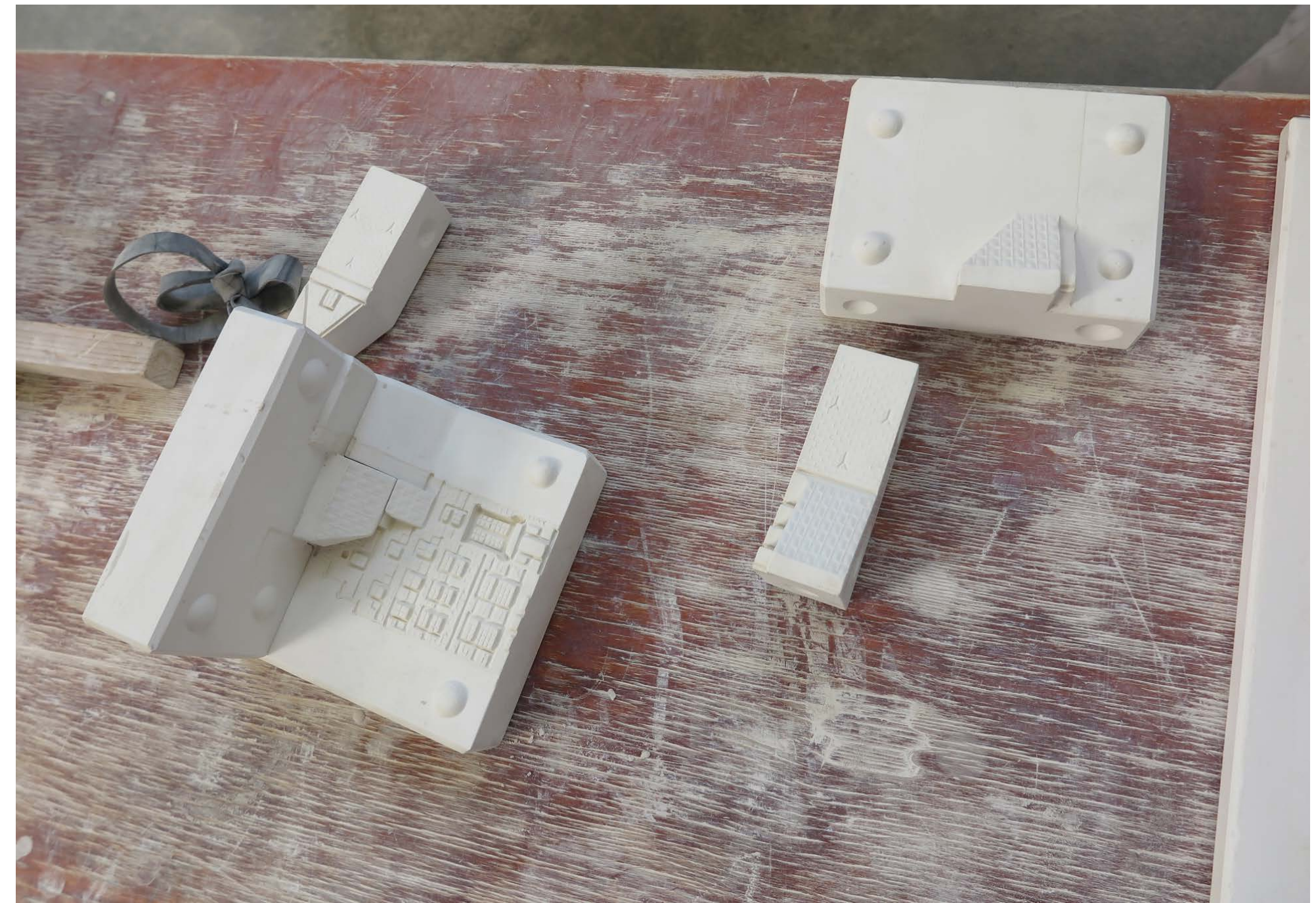

2. Heavily knowledge and skill reliant



# Design Drivers

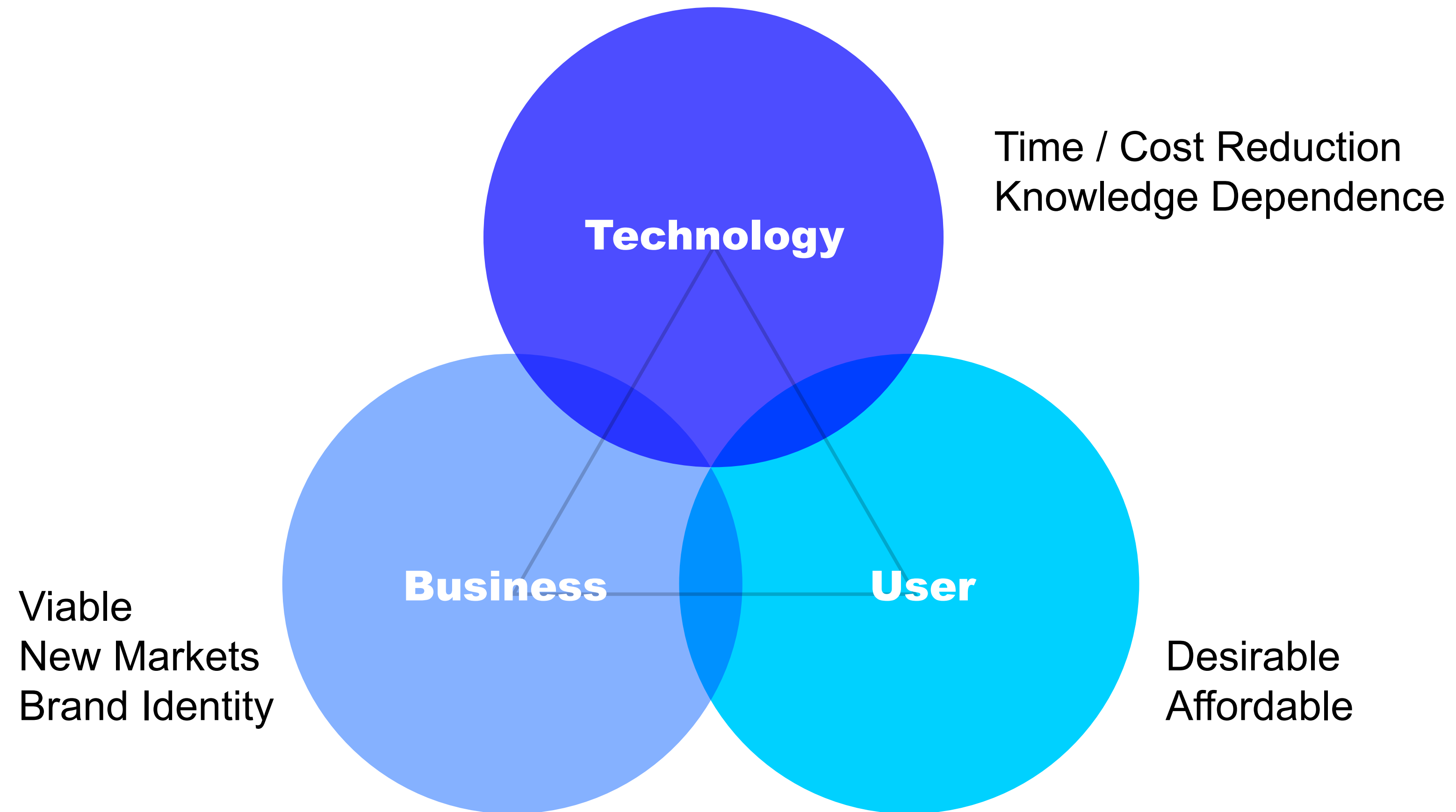



# 3. Ideation

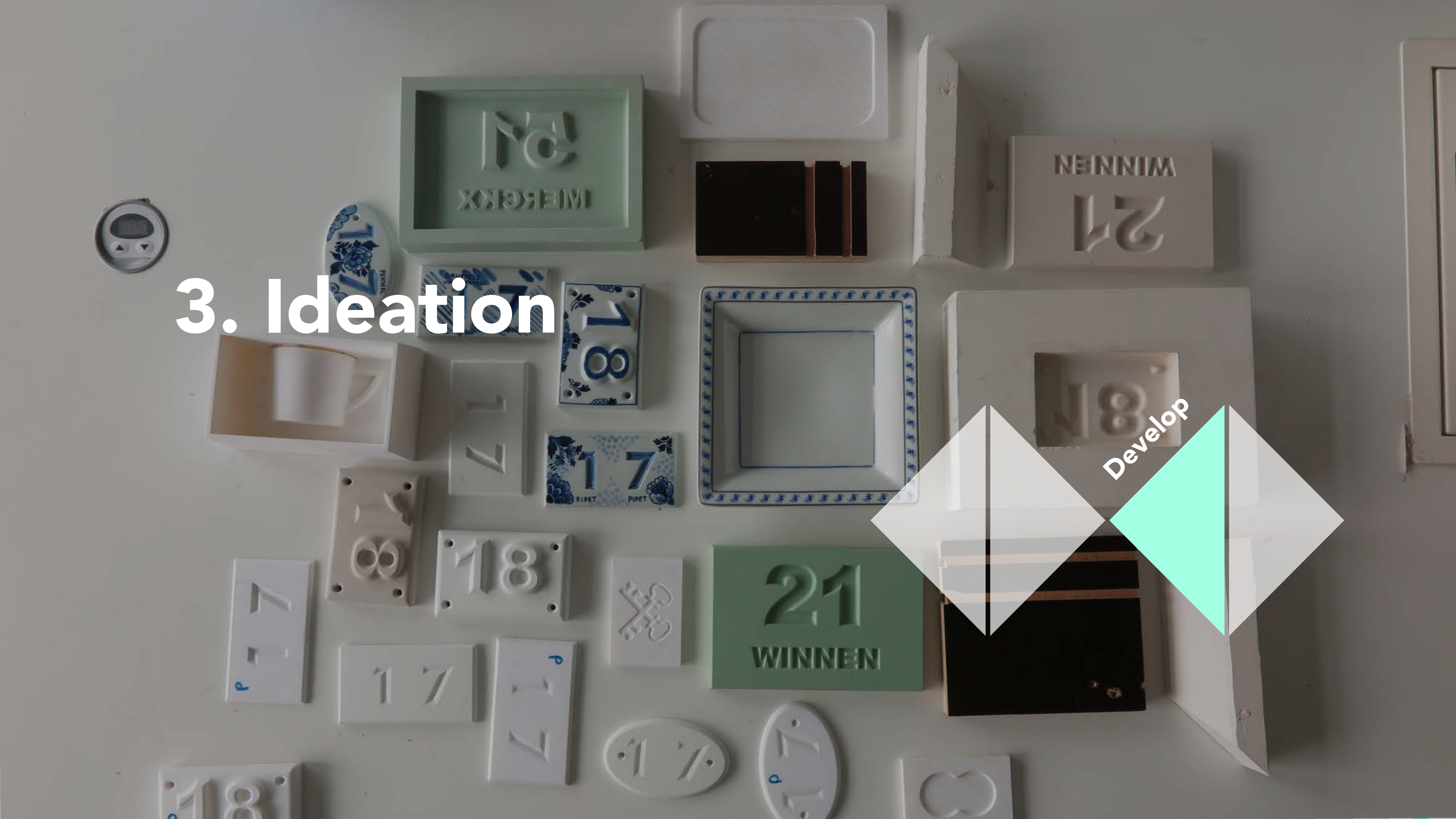



# Collecting

2D	Personalization	Hand painted	2.5D	Personalization	Letterbak	2.5D	Personalization	Letterbak	Custom logo	3D	Personalization	Letterbak	Custom logo

← (low) Shape Specificness (high) →

<p>THIS PLANTER</p> <p>OR THIS...</p> <p>OR THIS...</p> <p>OR THIS...</p>	<p>modular vase parts</p> <p>Configuration defines shape</p>	<p>scalable mold parts</p> <p>Defining dimensions</p>	<p>mold inserts</p> <p>Changing details</p>	<p>modular mold voxels</p> <p>Defining the shape</p>
---	--	---	---	--

<p>Technology Description</p> <p>Specific Company</p> <p>Application Example</p> <p>Insights</p>	<p>Japanese 19th century calligraphy robot</p>	<p>3D printed model</p>	<p>3D printing directly</p>	<p>3D printed model</p> <p>Clearly visible lines</p> <p>3D printed model</p> <p>2 part glued + putty</p> <p>3D printed model</p> <p>Lost PLA metal casting</p> <p>3D printed model</p> <p>3D printed mother mold</p> <p>Keys on 2 mold parts are not equally sized, as plaster requires.</p> <p>3D printing with the right settings can result in perfectly fitting mold parts.</p> <p>3D printed roller tool</p> <p>3D printed mother mold</p> <p>Joinery prevents leaking</p> <p>Balloon / rubber provides quick-release surface.</p> <p>Aaron dunkerton</p> <p>Slip cast in plaster board</p> <p>3D printed roller tool</p> <p>3D printed mold for direct concrete cast</p> <p>3D printed mold</p> <p>Learn to prevent printing issues</p> <p>hour printing the alpha print, merge</p> <p>Screw to wood</p> <p>Channels = steel rods</p> <p>Staples = the shape out</p> <p>Magnets = metal bed</p> <p>Sponge insert?</p> <p>Softest Polypropylene</p> <p>Paper</p> <p>Waterjet cutting</p>	<p>3D printed model</p> <p>3D printing directly</p> <p>3D printing directly</p> <p>3D printing directly</p> <p>We are the robots</p> <p>Automatic slip casting</p> <p>Casting + jollying</p> <p>High pressure</p> <p>Robots sanding/modifying biscuit</p> <p>Apulum porcelain</p> <p>Silicon Nitride milling</p> <p>Mastec CNC</p> <p>5 axial CNC machining plaster</p> <p>porous resin mold</p> <p>High pressure</p> <p>Large production numbers allow for automated production line</p> <p>CNC Lathe turning</p> <p>Silicon Nitride milling</p> <p>CeramTec BIOLOX</p> <p>Ball-joints (medical)</p> <p>CNC foam for plaster cast of faces</p>
--	--	-------------------------	-----------------------------	---	---







# Prototyping

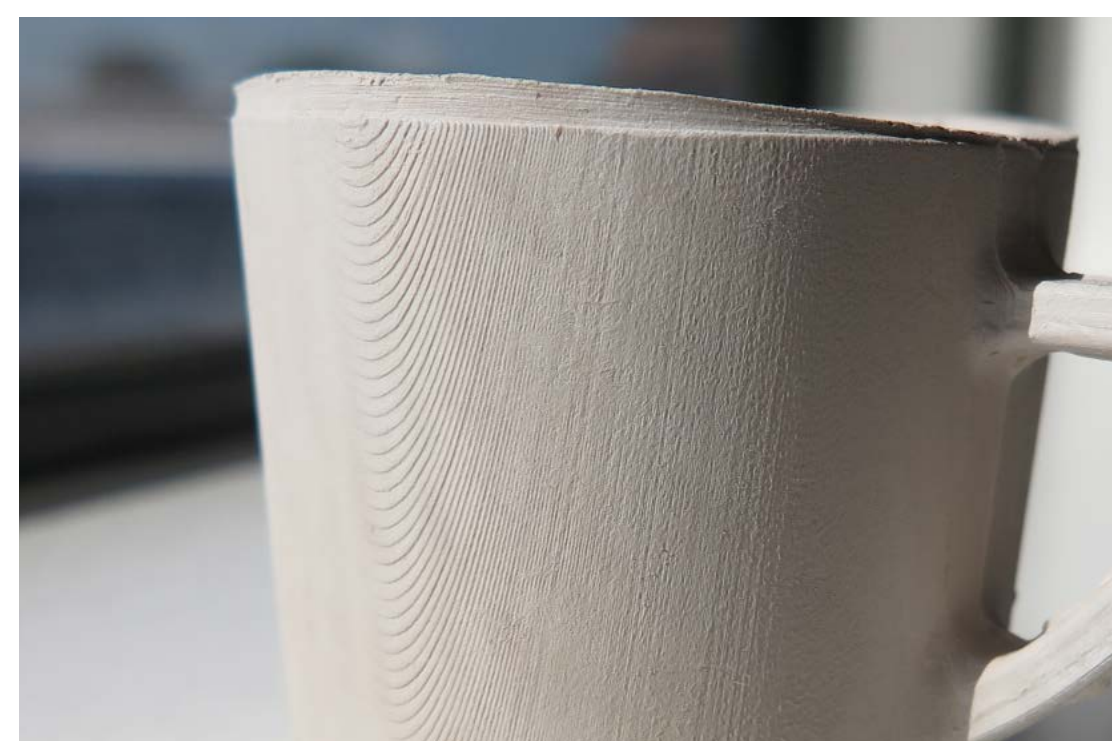
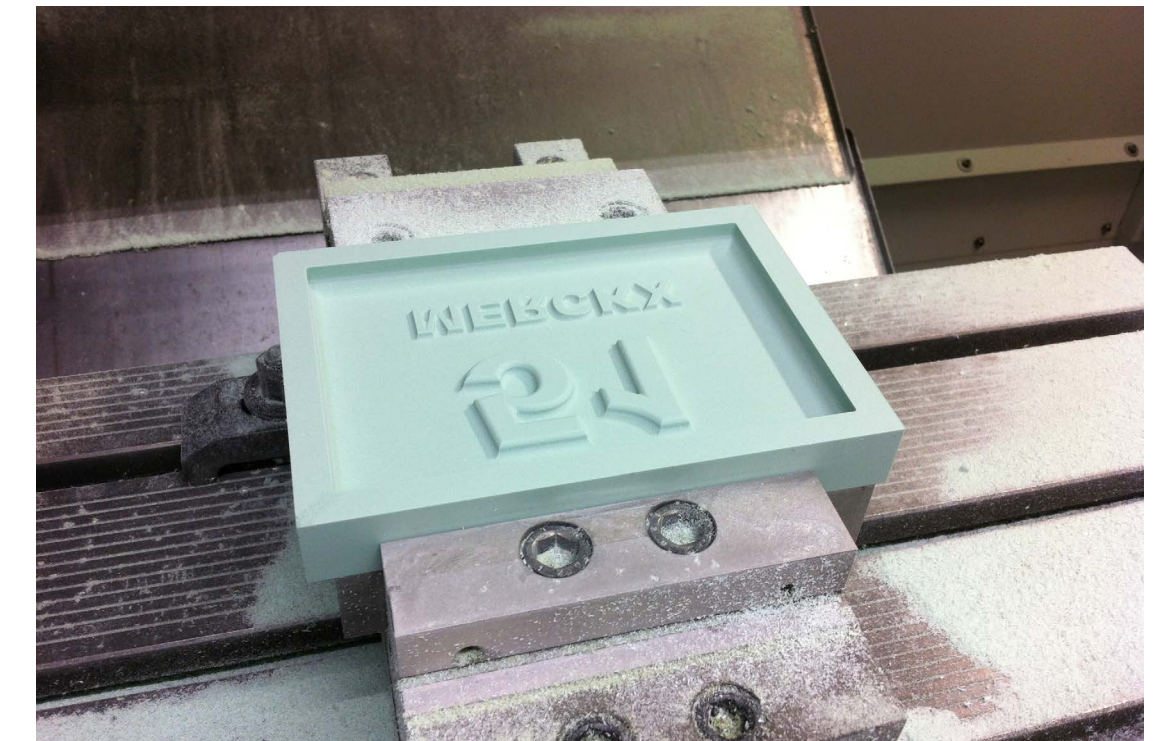
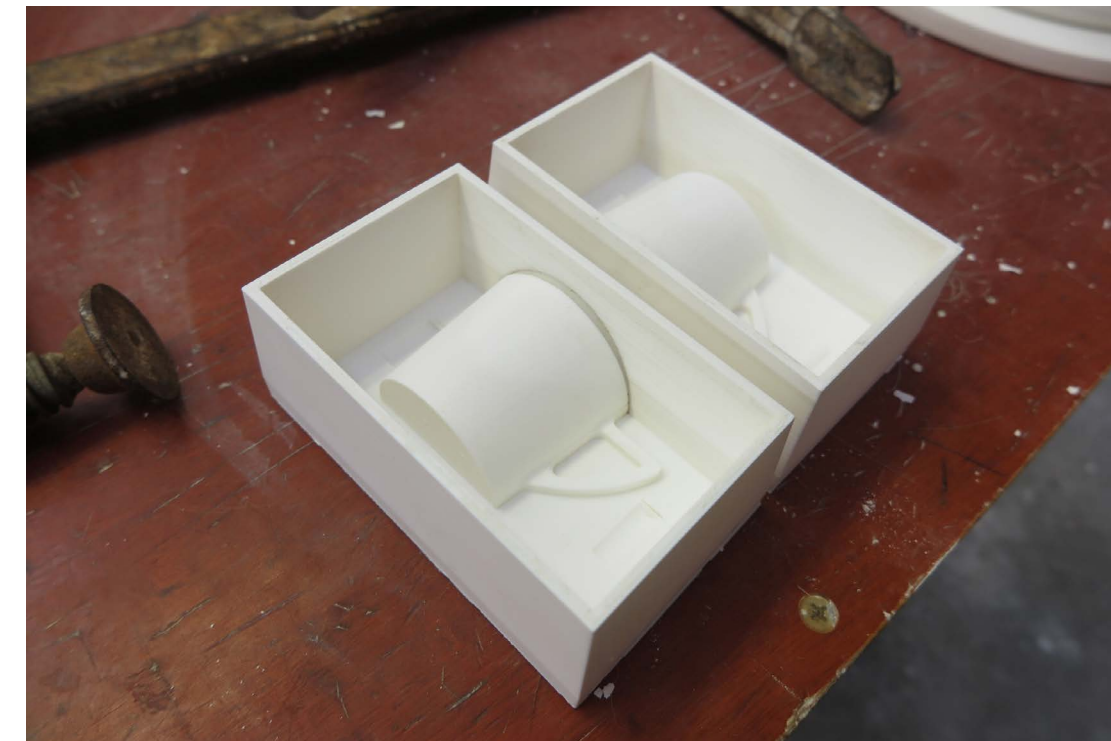
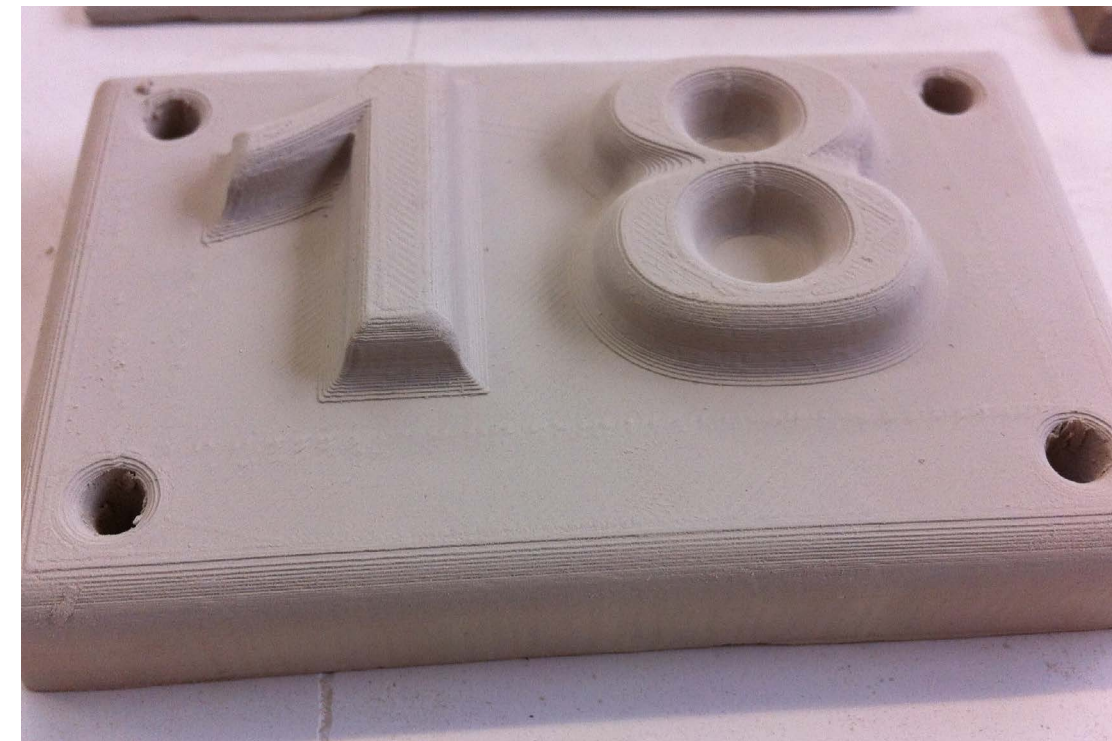
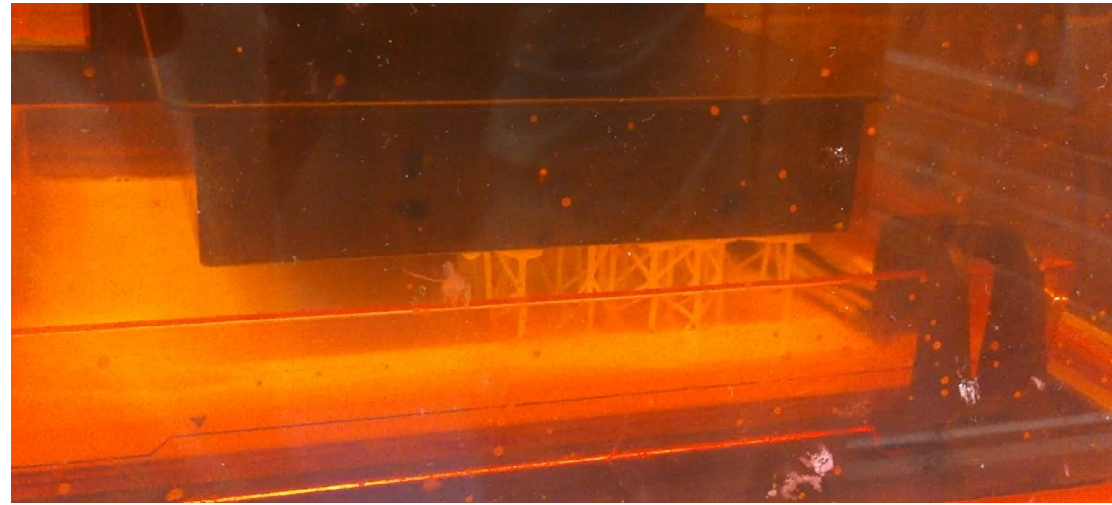



# Concept Generation



1. Relief Mug



2. Personalized Tray

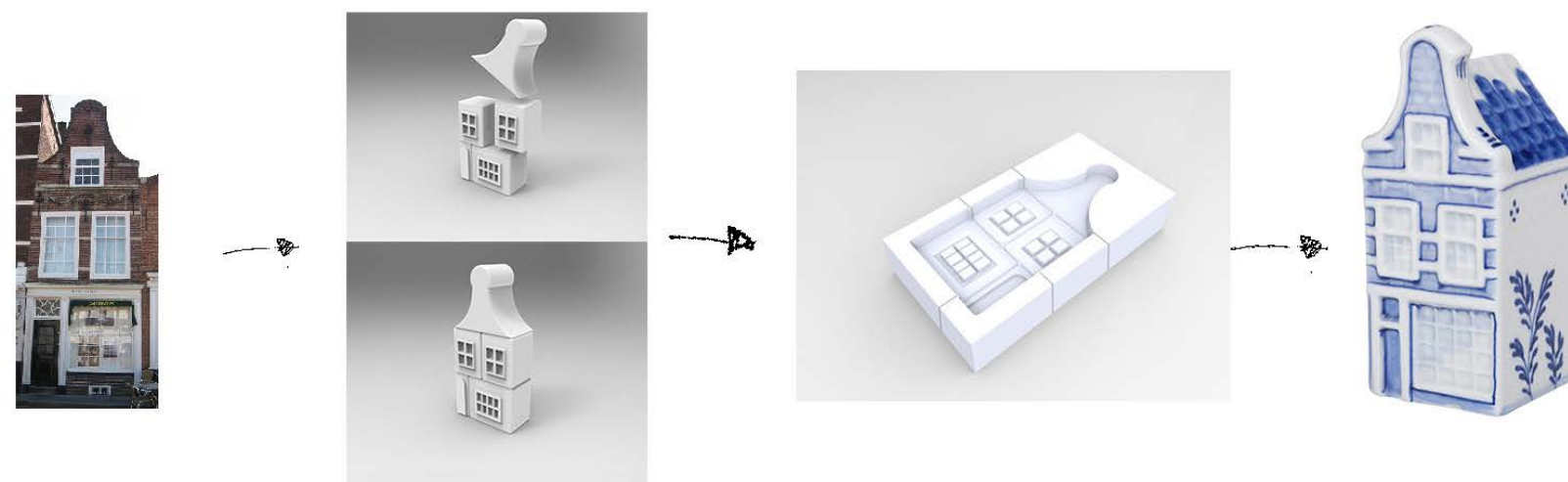

3. Miniature House



4. Name & Numberplate



# Concept Generation



1. Relief Mug



2. Personalized Tray

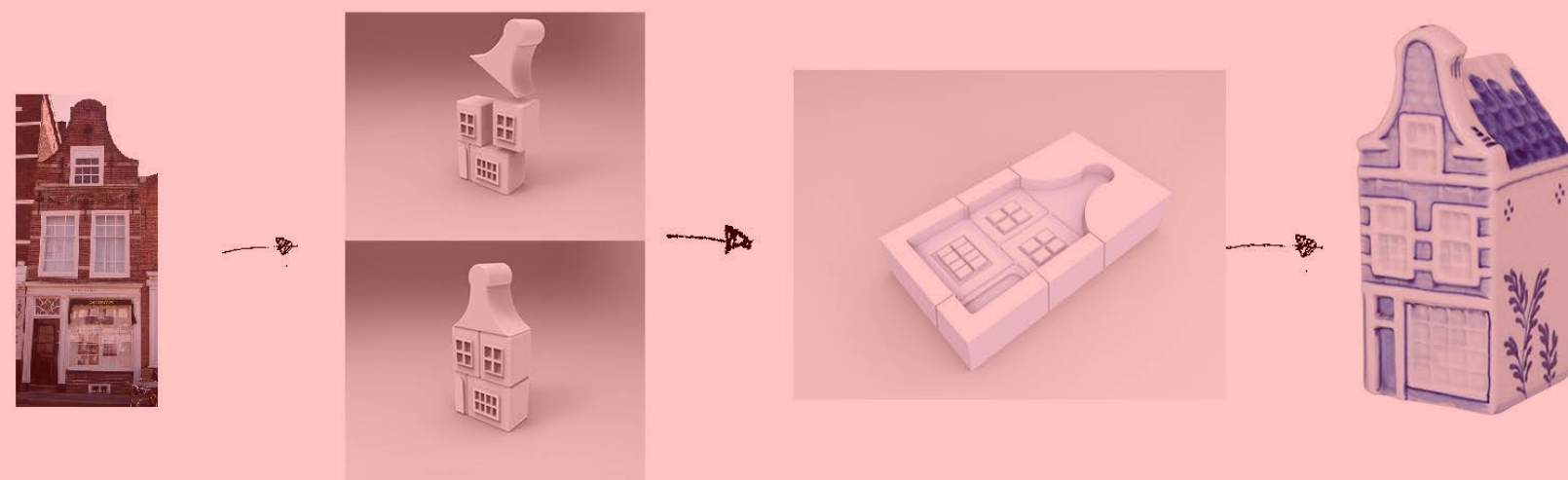

3. Miniature House



4. Name & Numberplate



# Concept Generation



1. Relief Mug

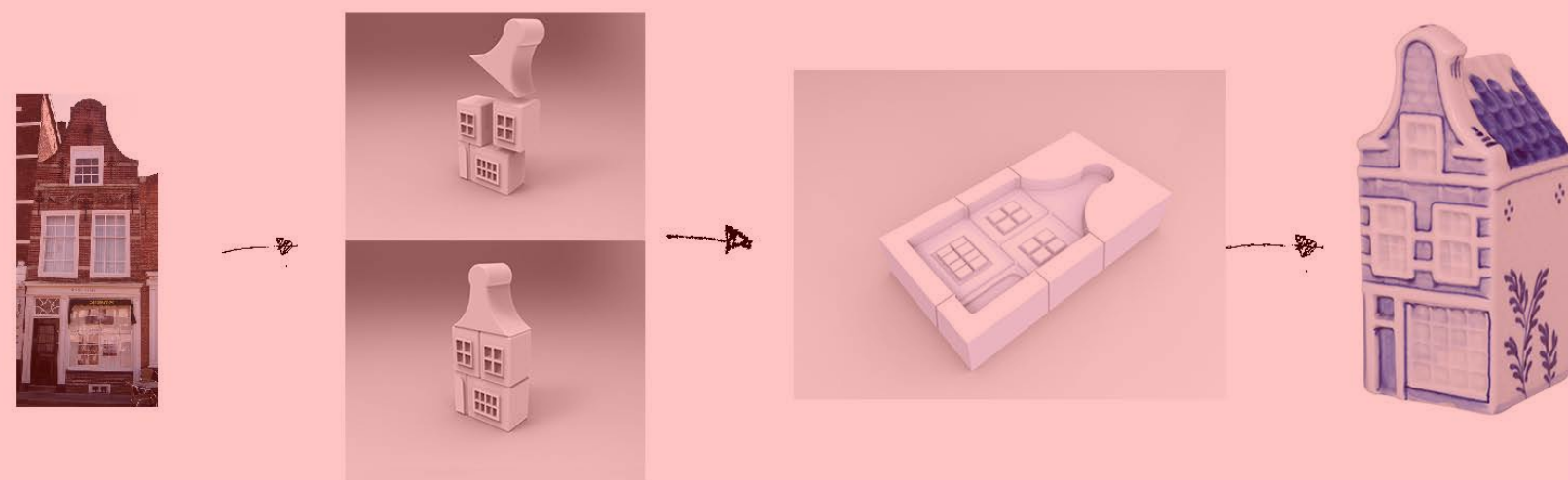

3. Miniature House

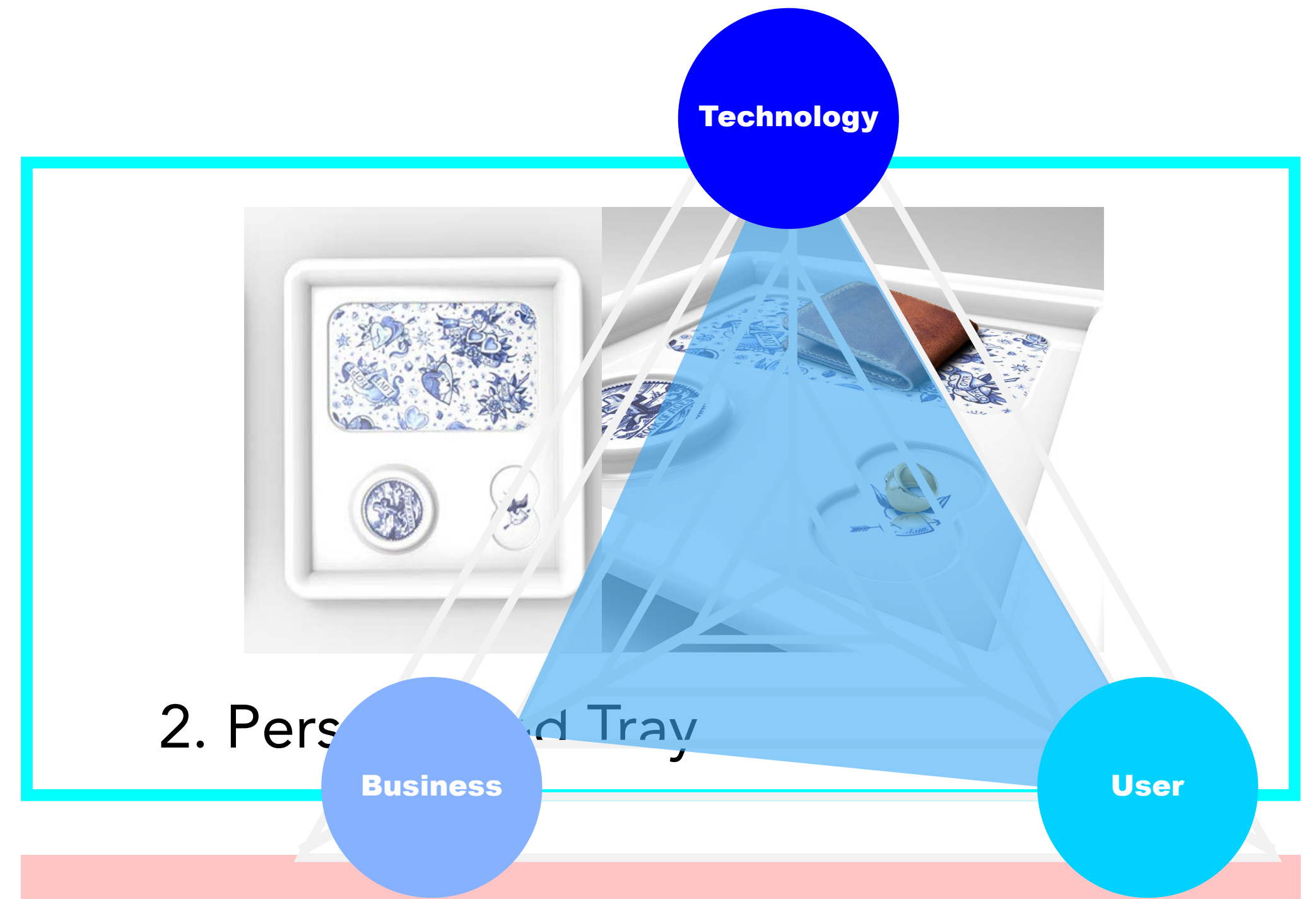

2. Personalized Tray



4. Name & Numberplate



# Personalized Tray



1. Configure

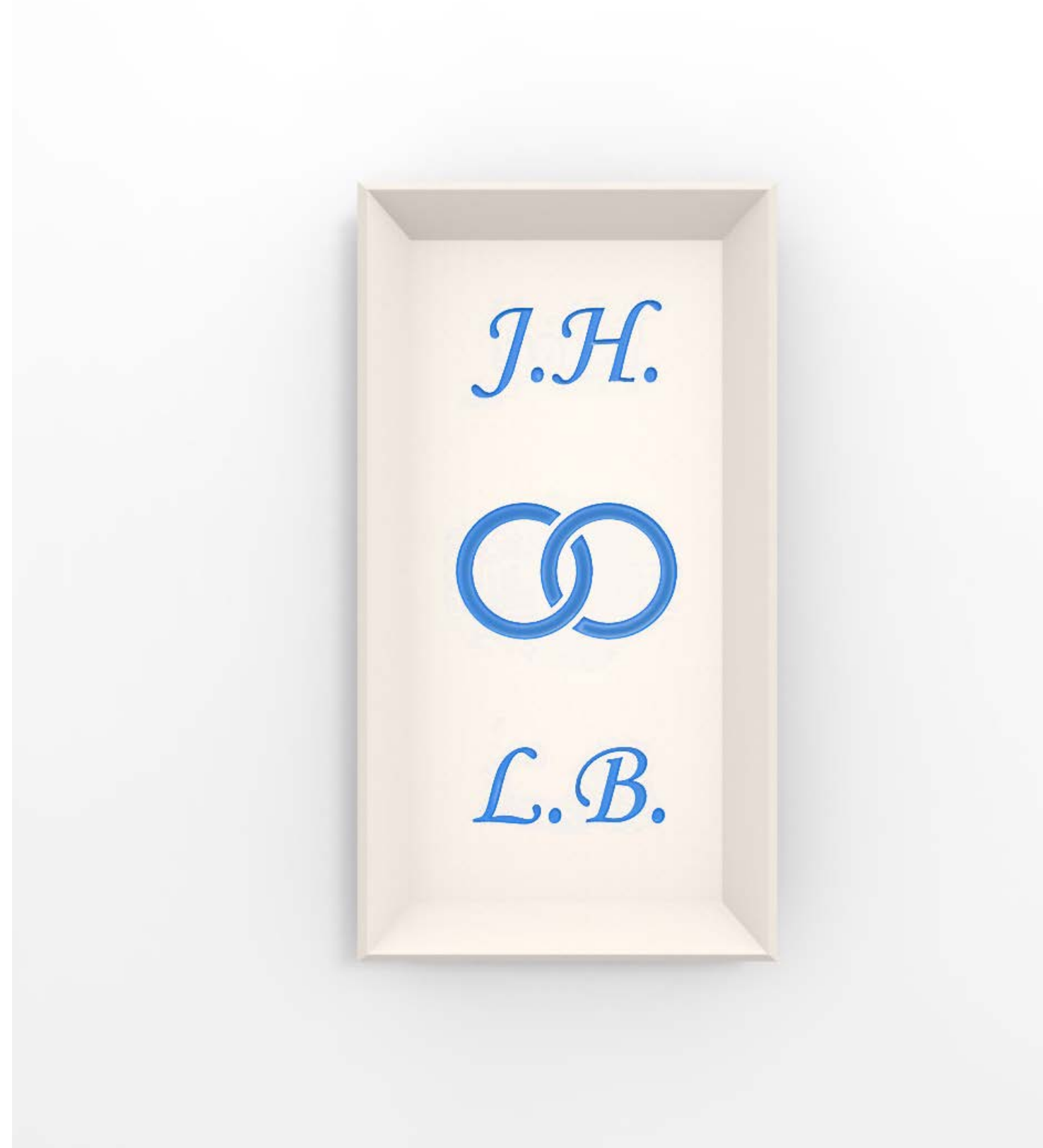

2. Text

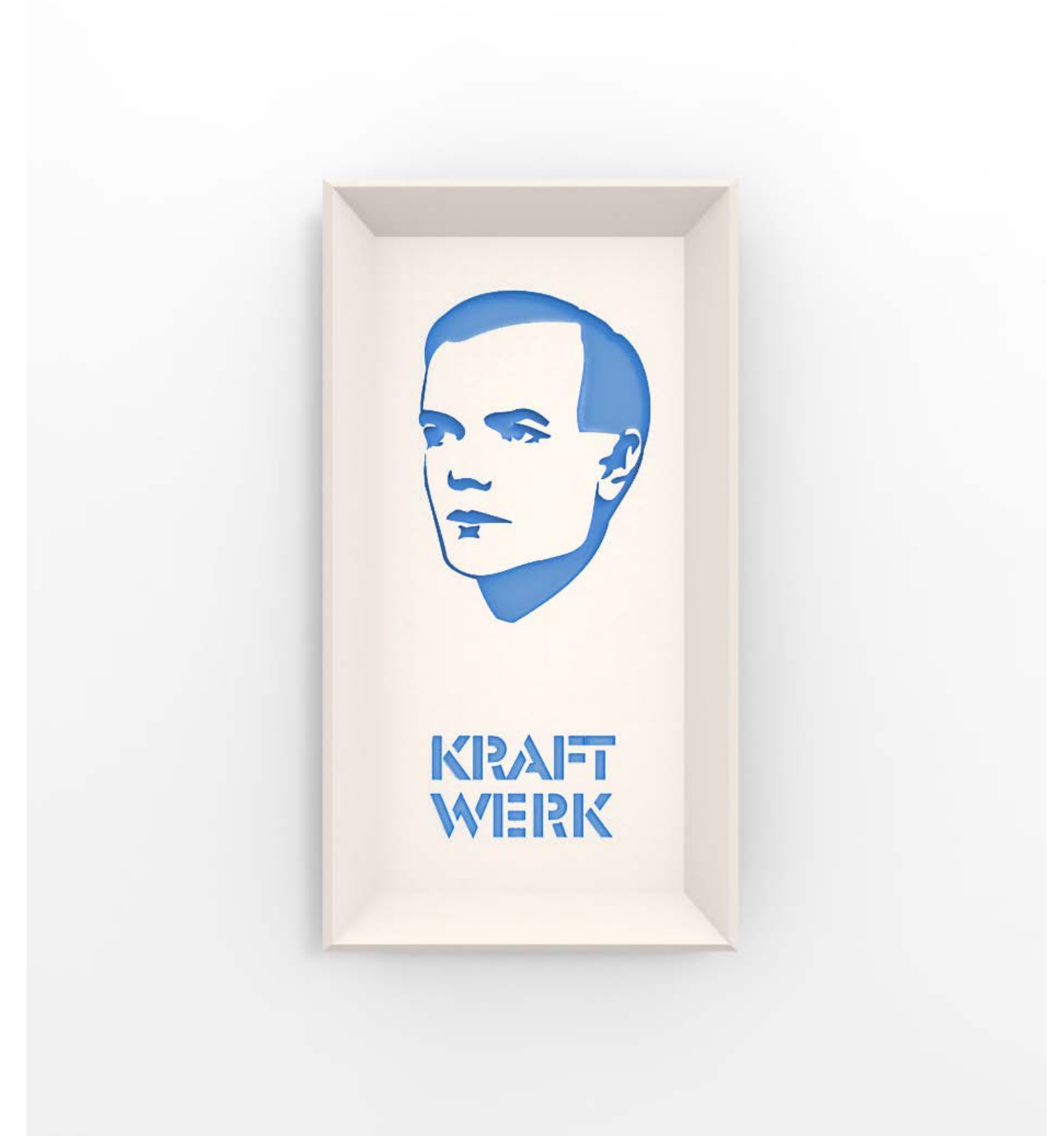

3. Custom Vector







# 4. Implementation

Deliver





# Personalized Tray - Trajectory Steps

1. User places order

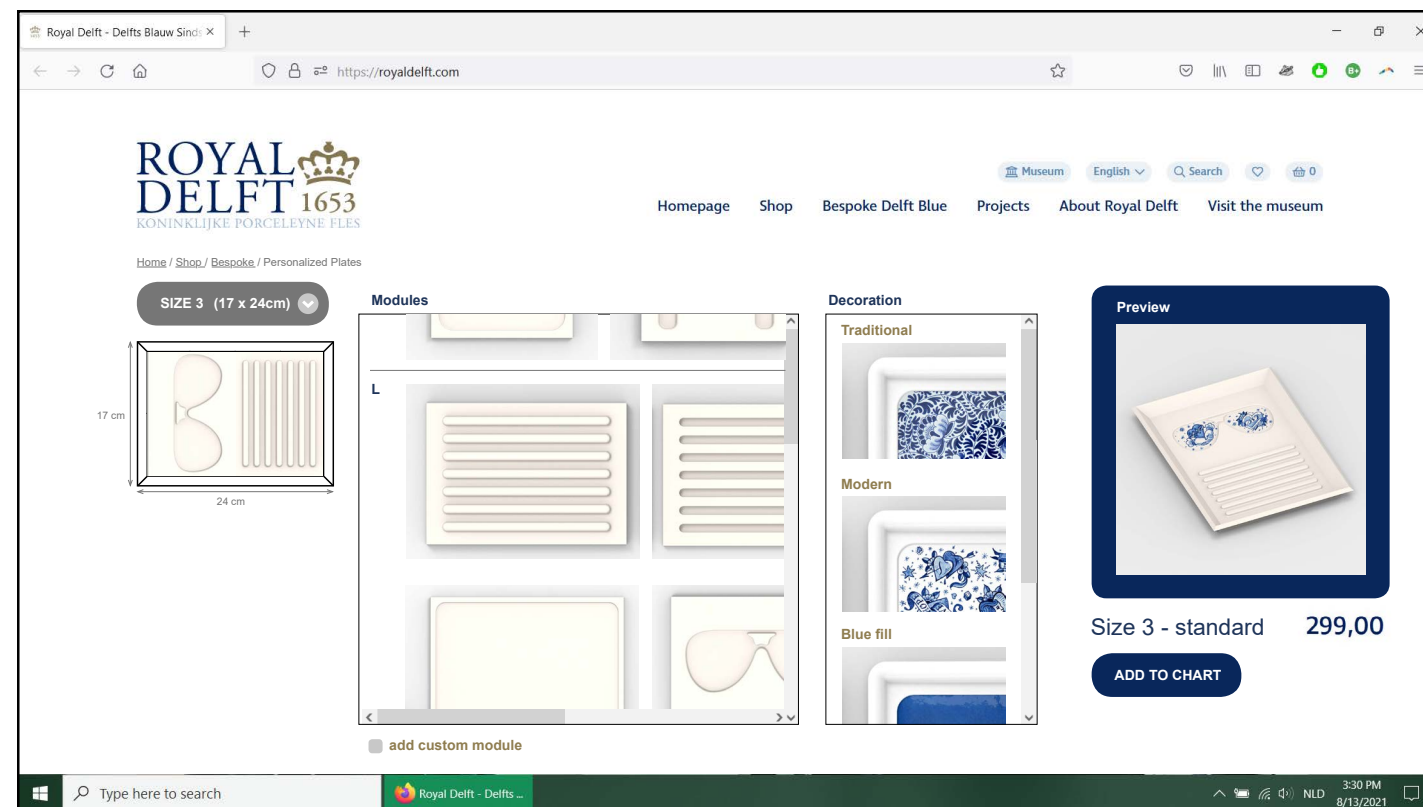

(2. Printing custom module)

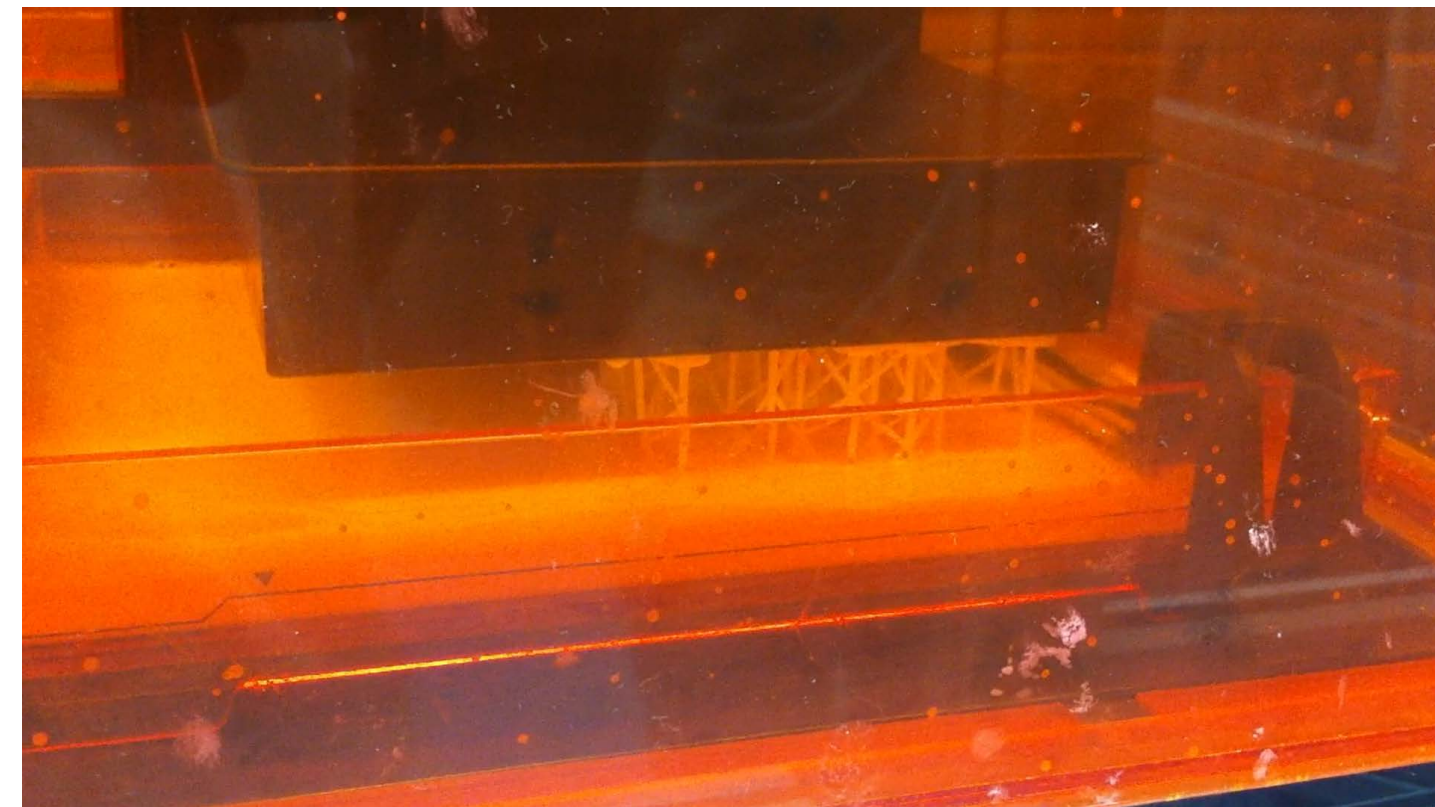

3. Mold Assembly





# Tray Production

## Current Trajectory

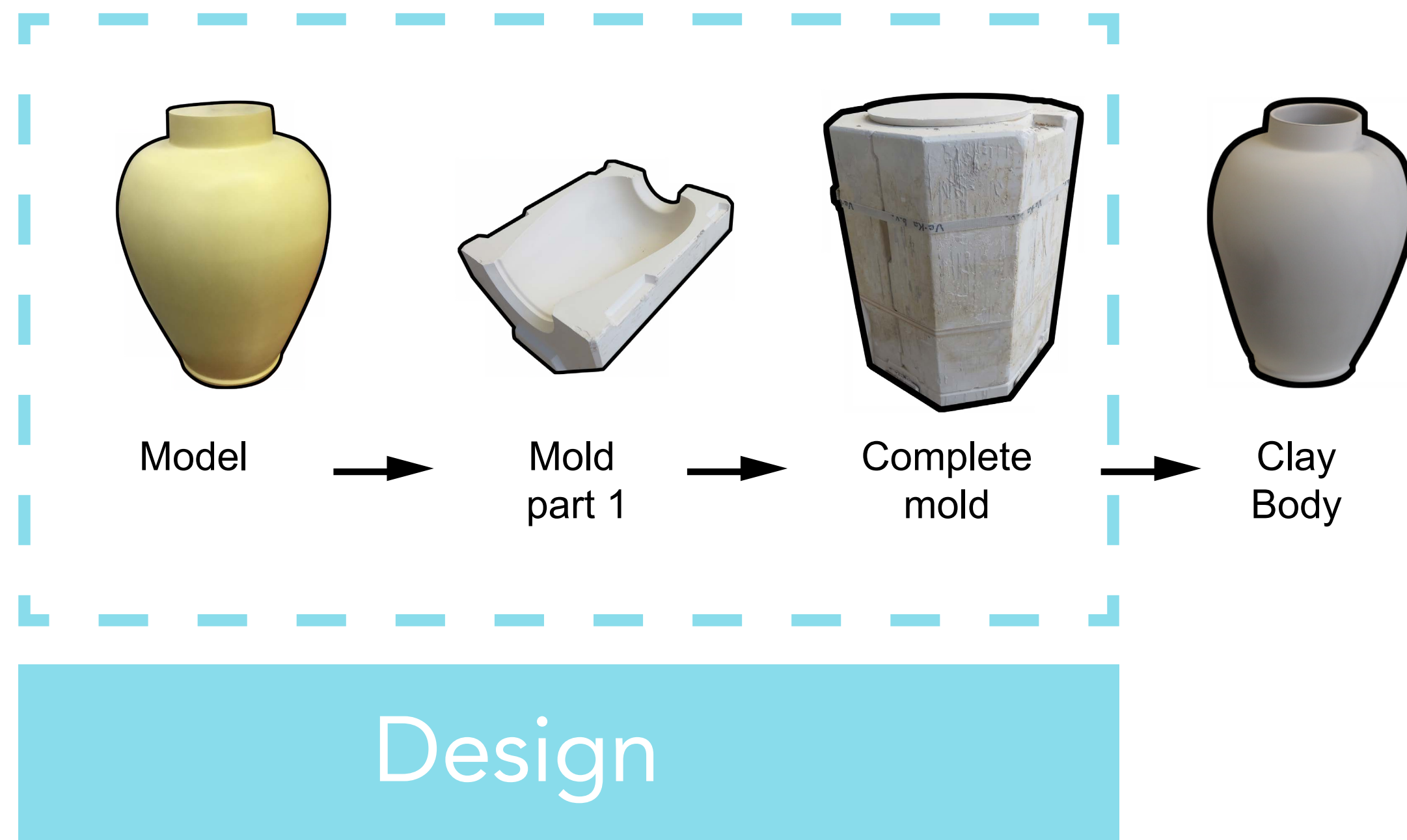

## New Trajectory

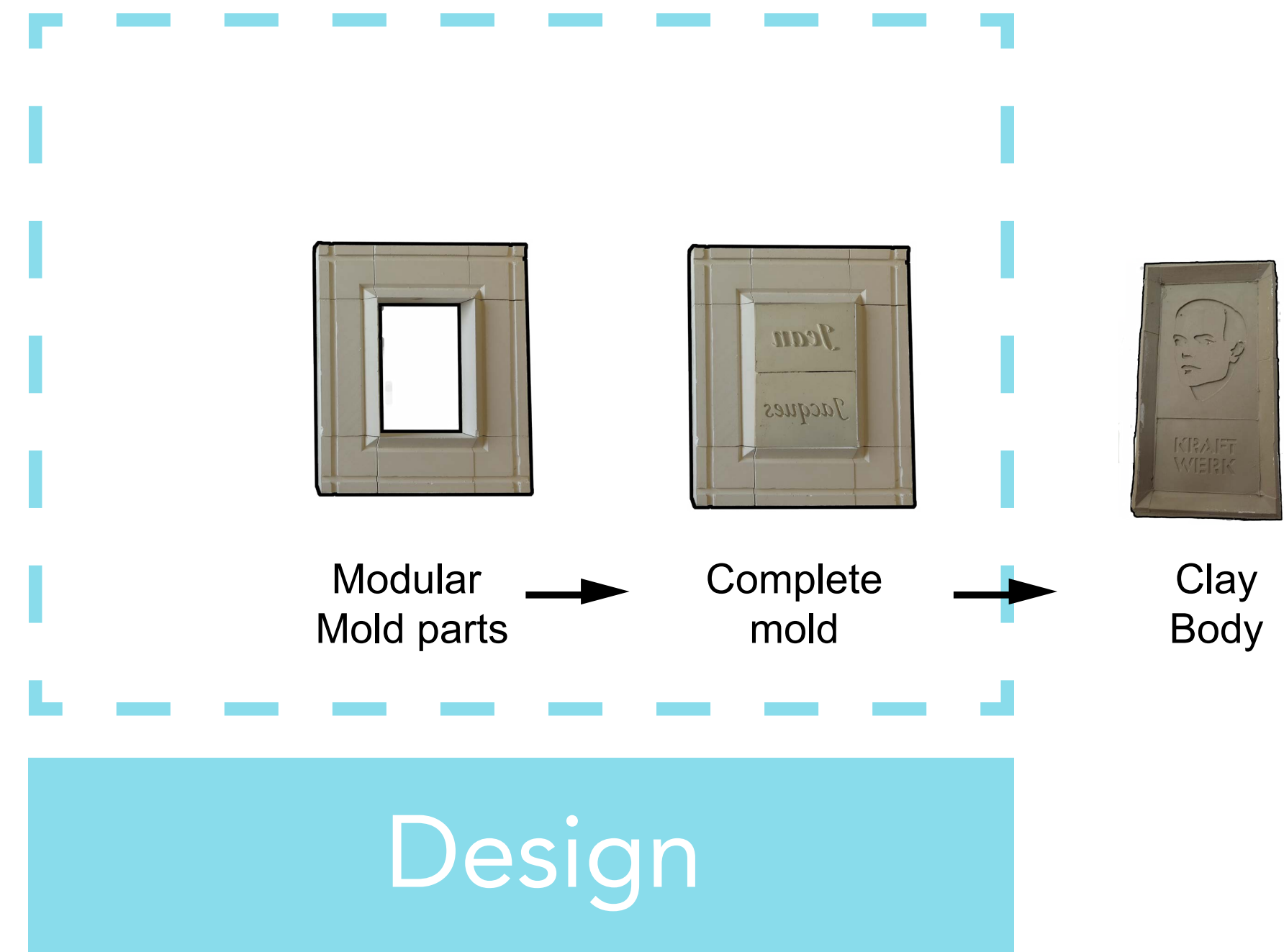



# Tray Production

## Current Trajectory

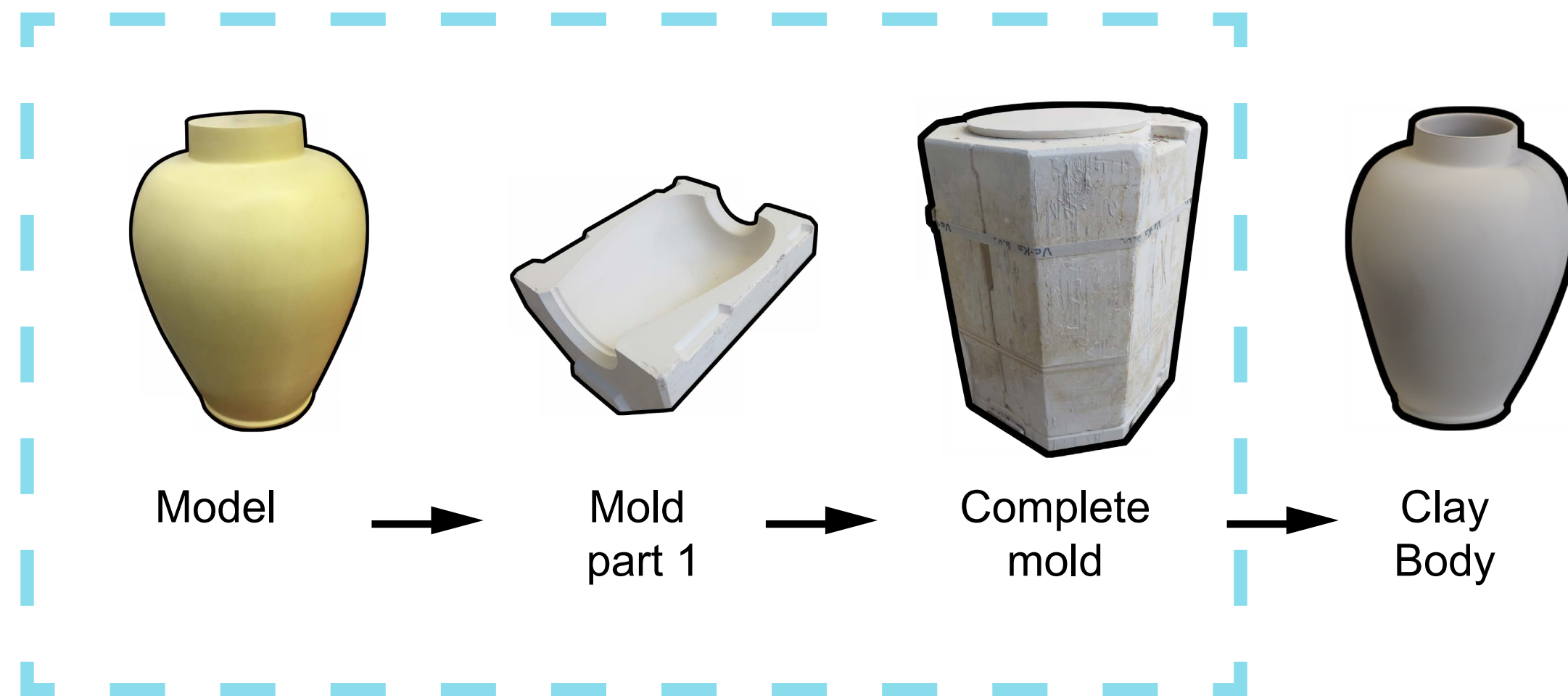

Design

## New Trajectory

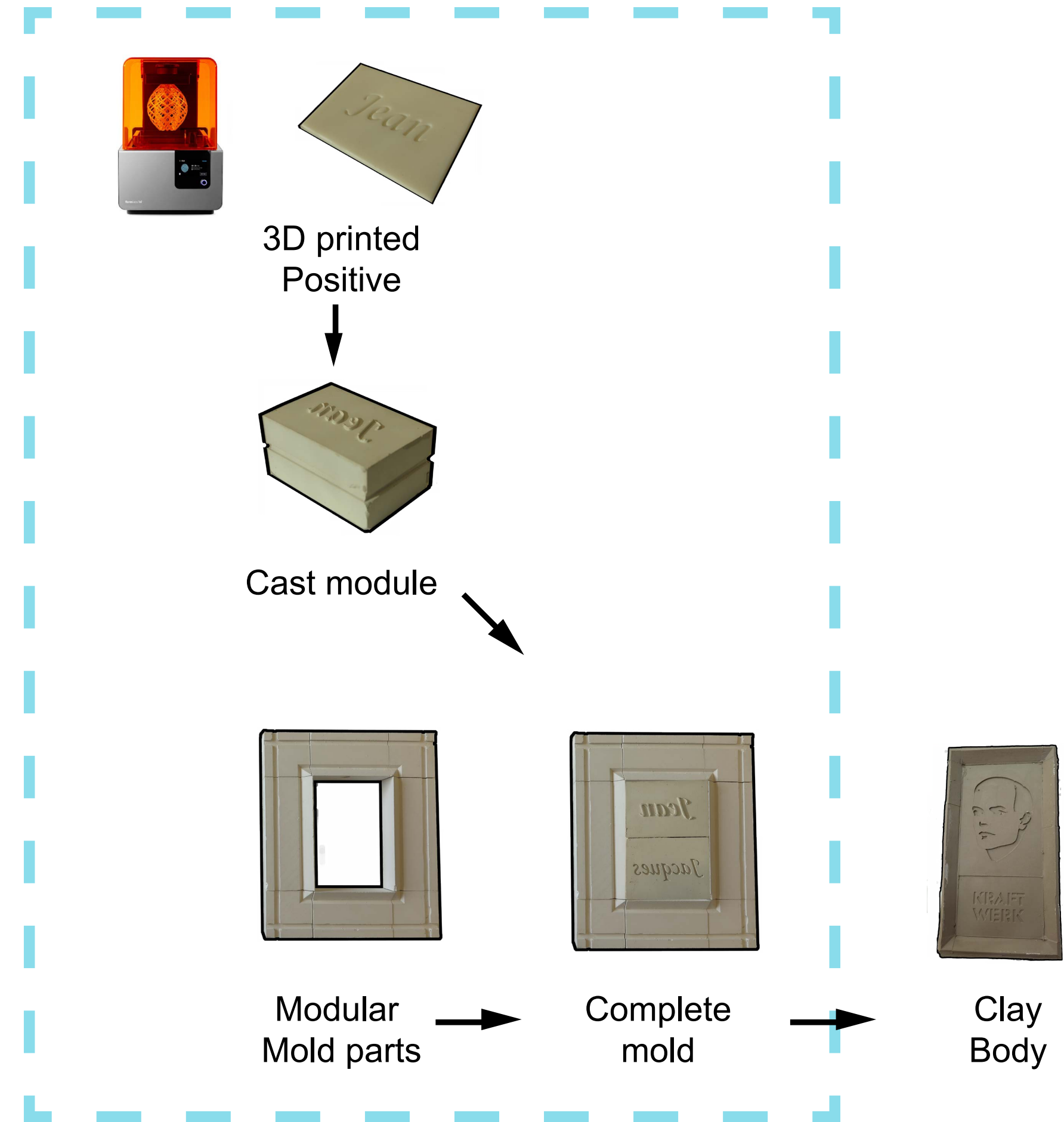

Design



# Mold - Versions

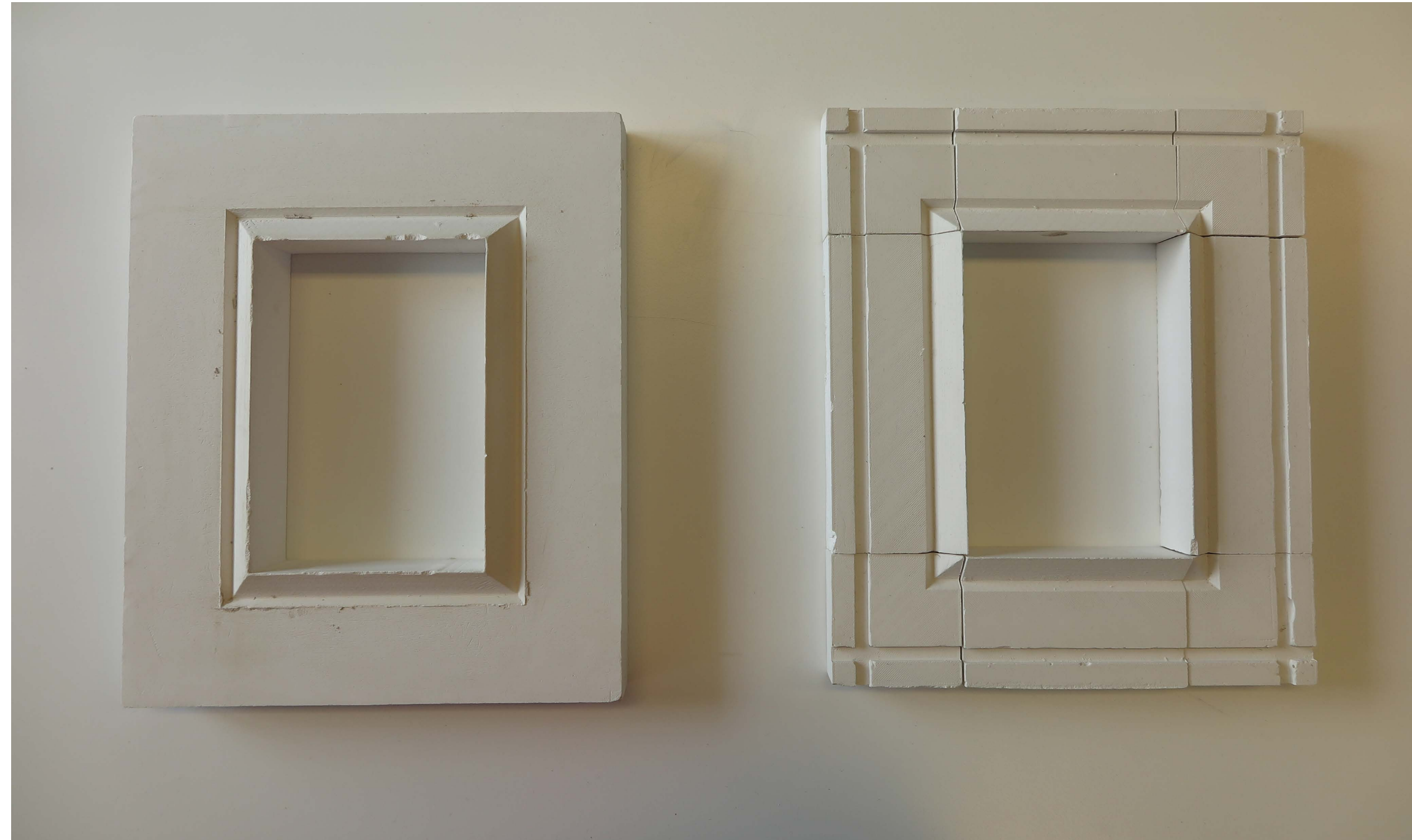

Version 1:  
Fixed Brim

Version 2:  
Modular elements



# Mold - Sides

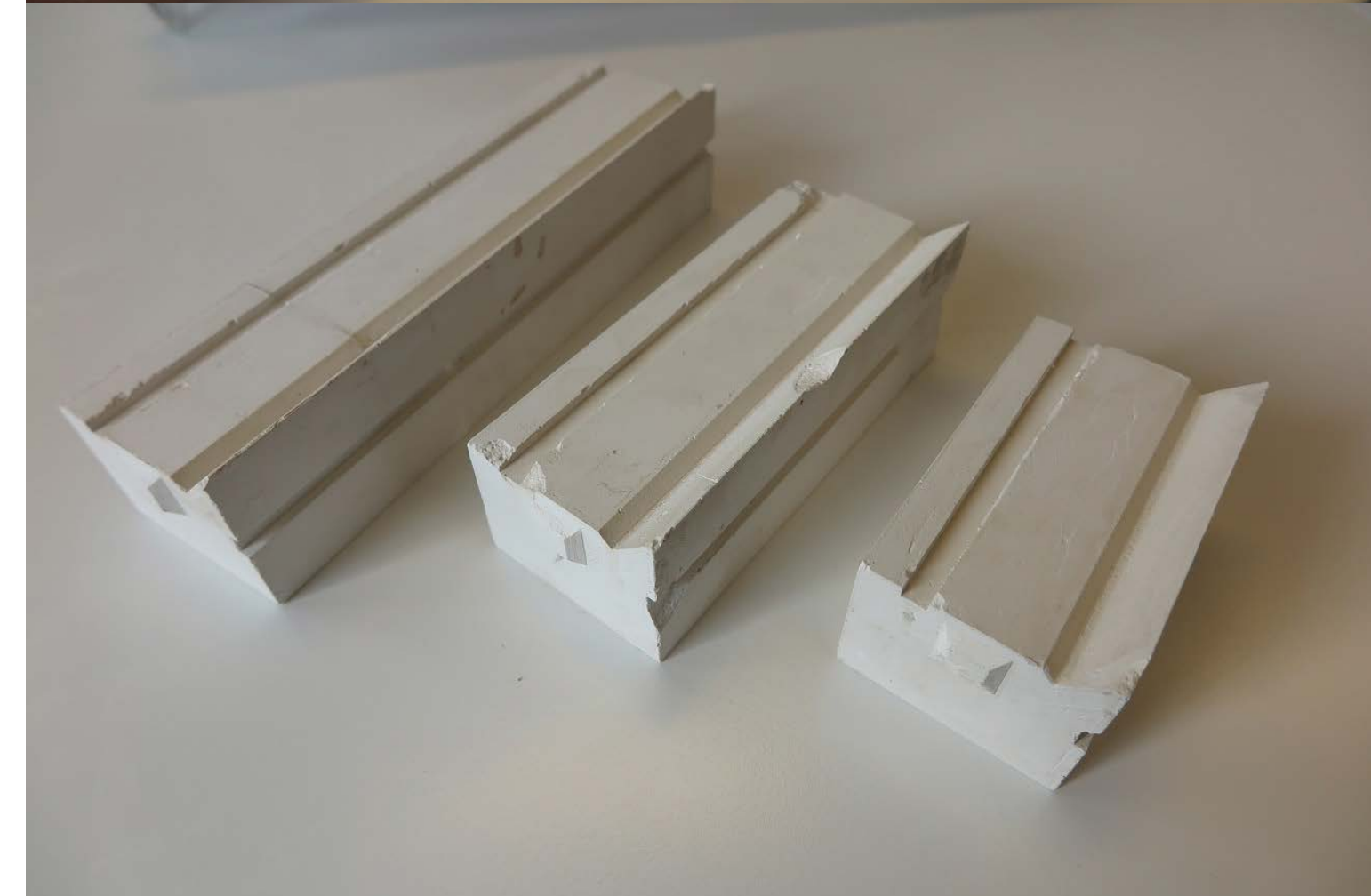
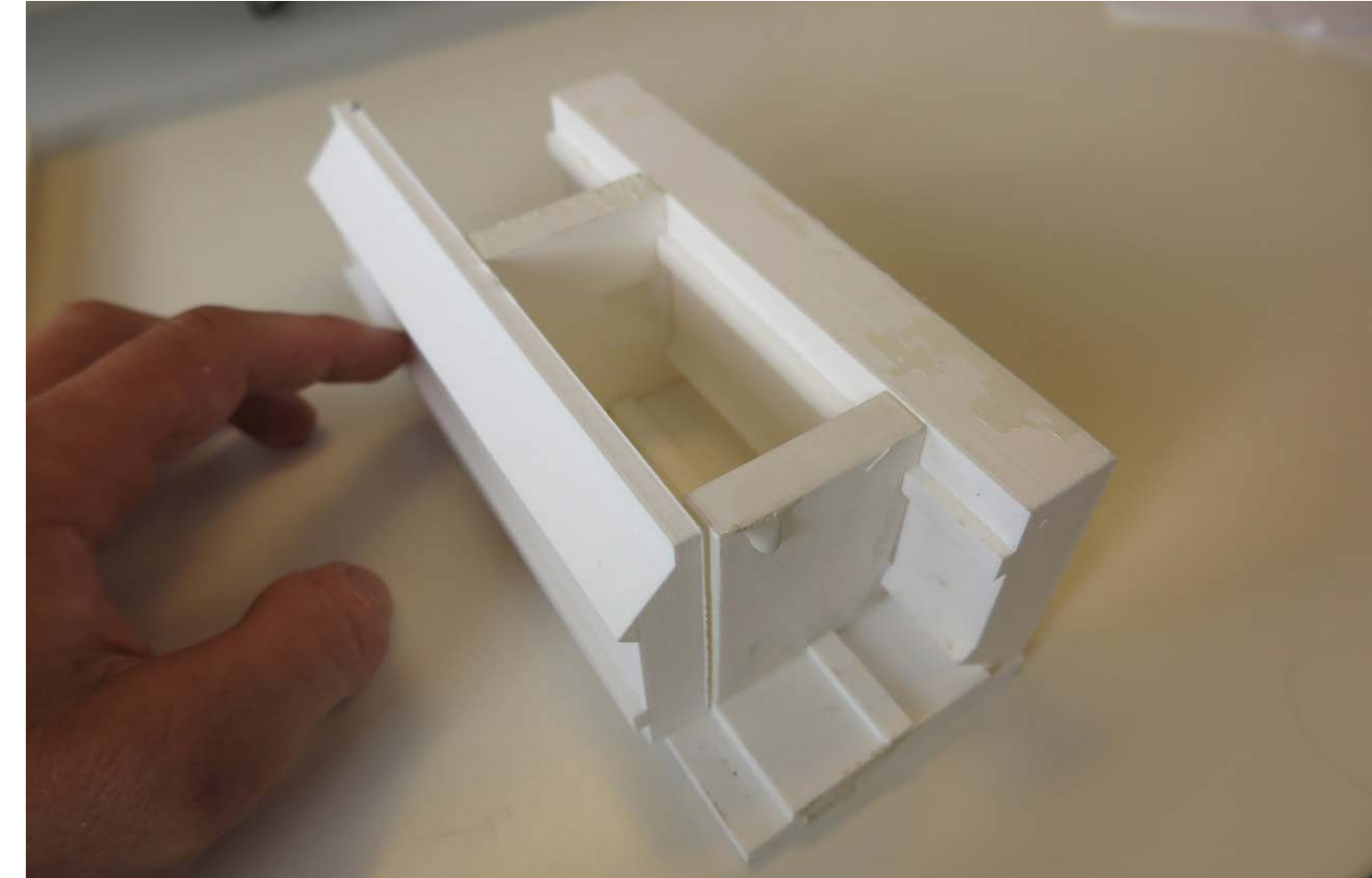
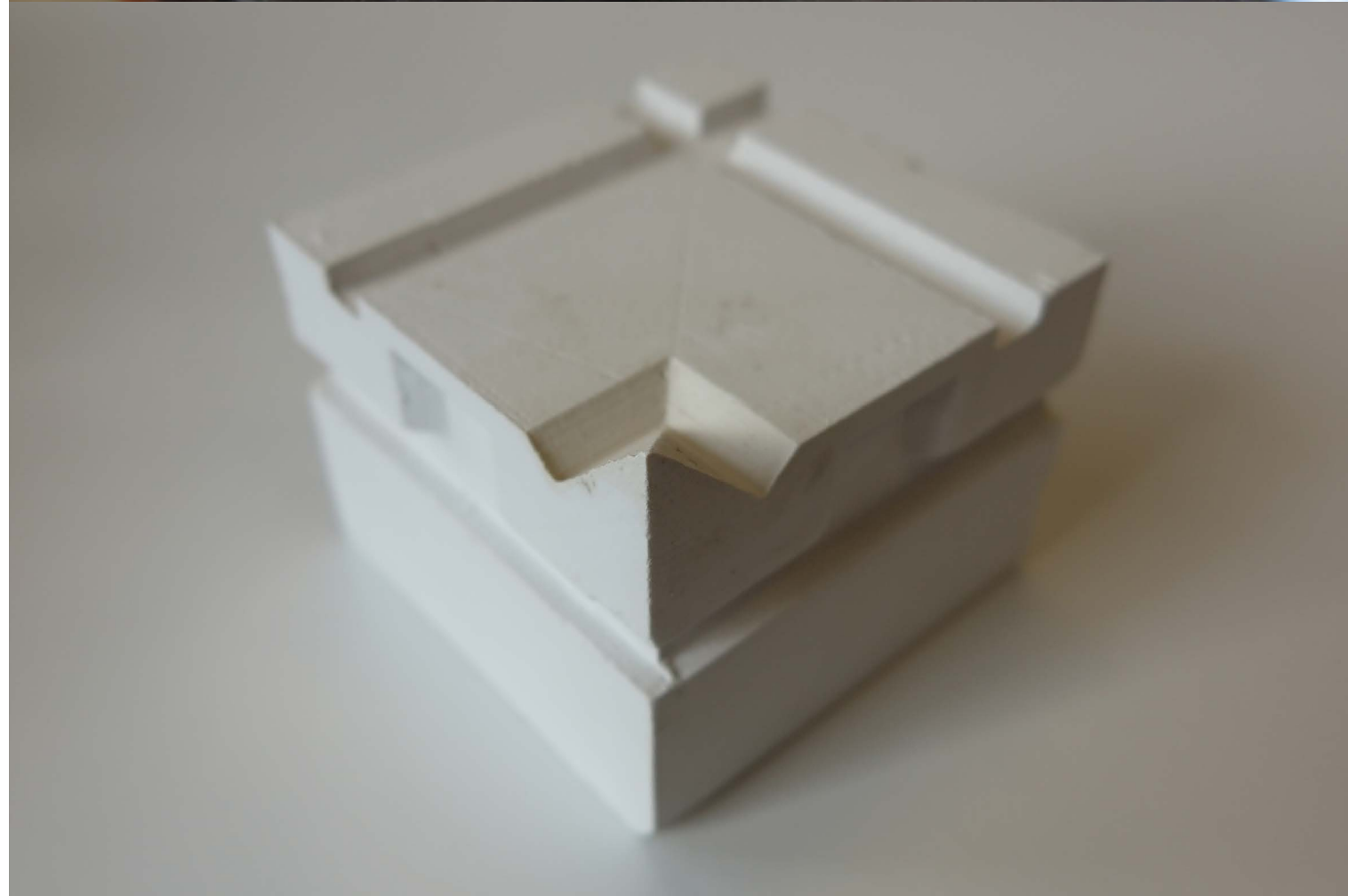



# Mold - Inserts





# Mold - Inserts





# Production





# Production





# Production





# Production





# Production

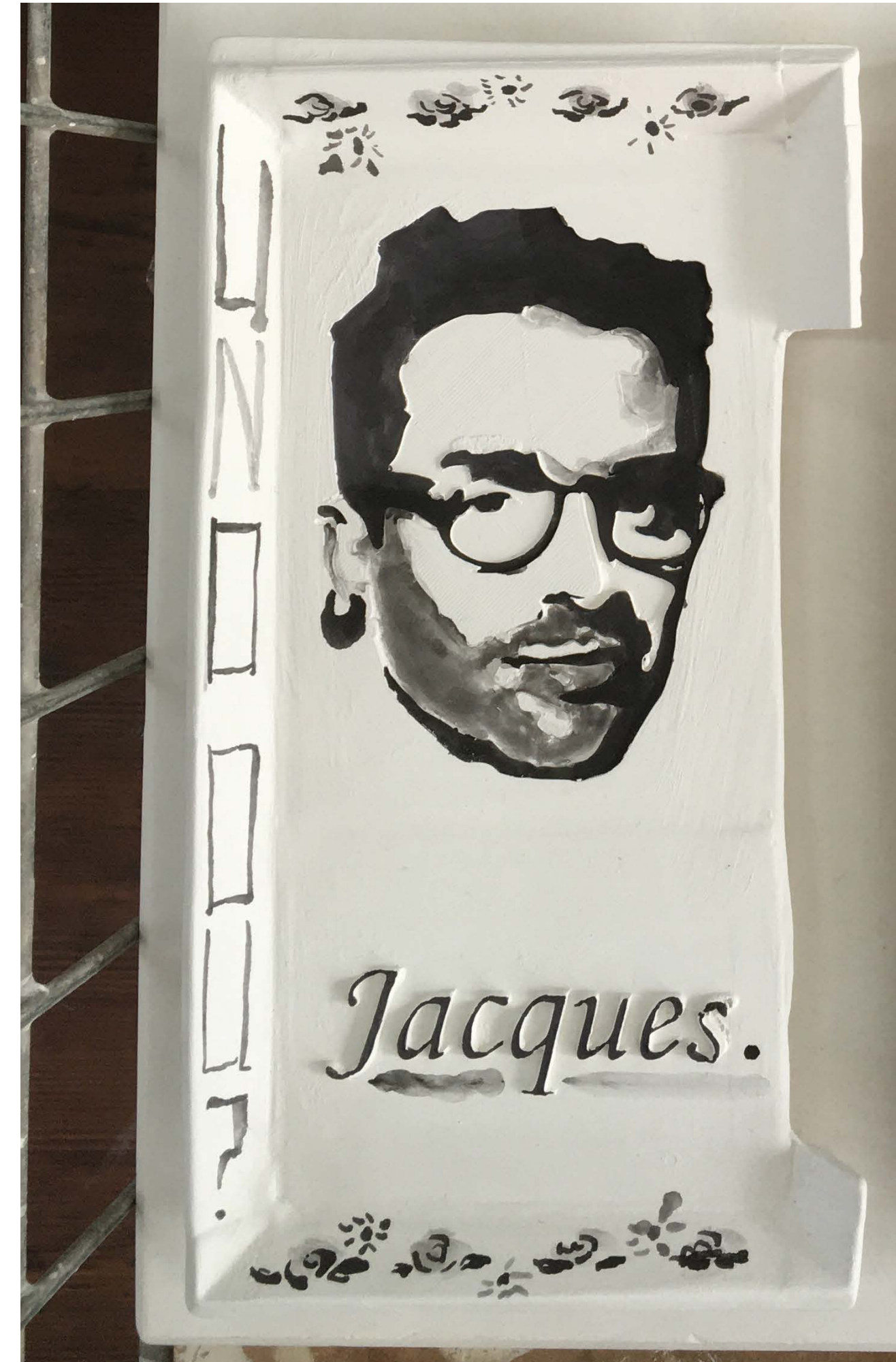



# Production





# Prototyping Improvements

Geometric shape  
Surface quality  
Angles  
Block dimensions





# Future stage 1: Flat shapes

Predetermined "Relief custom shapes"

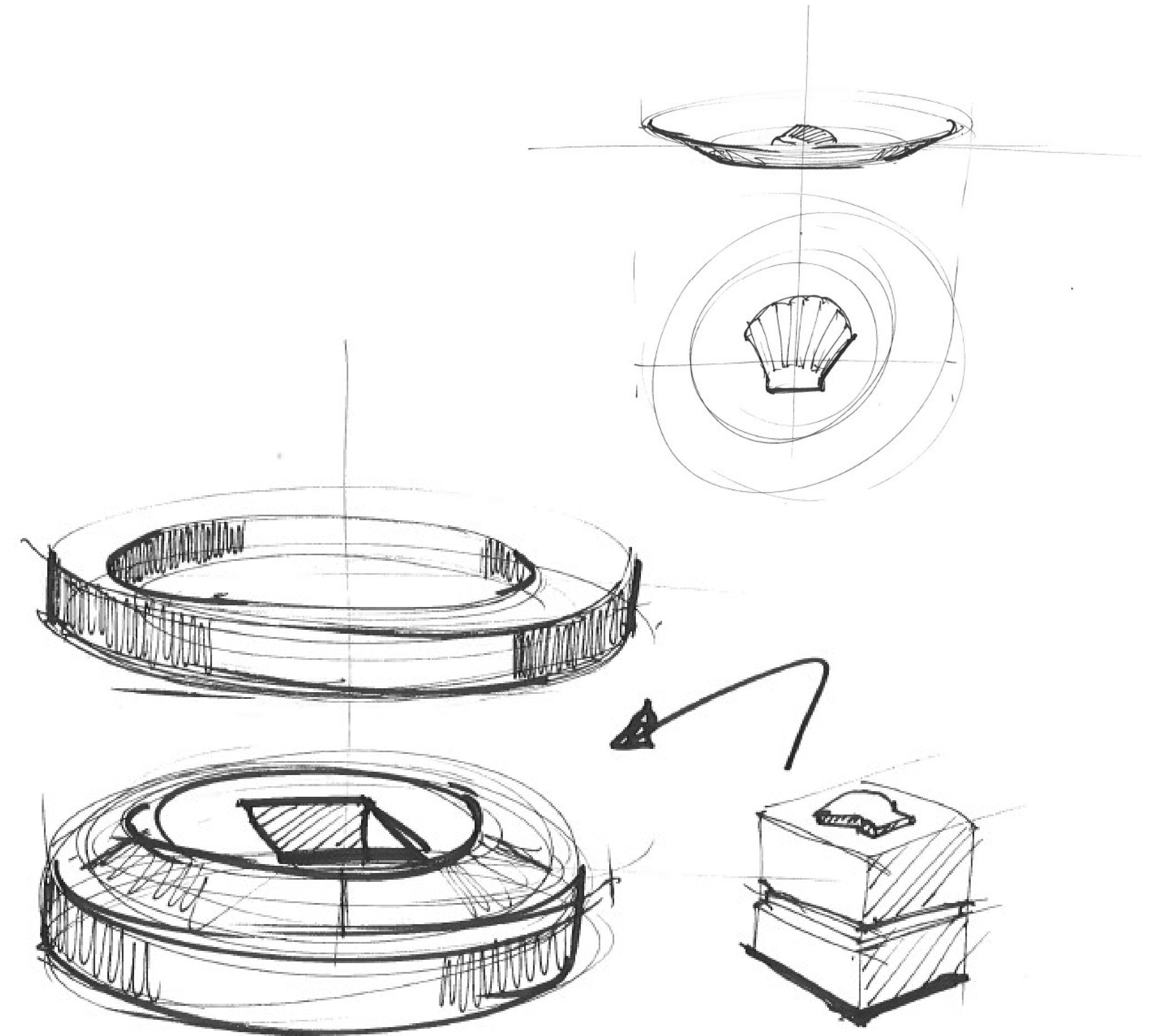



# Future stage 2: Contours

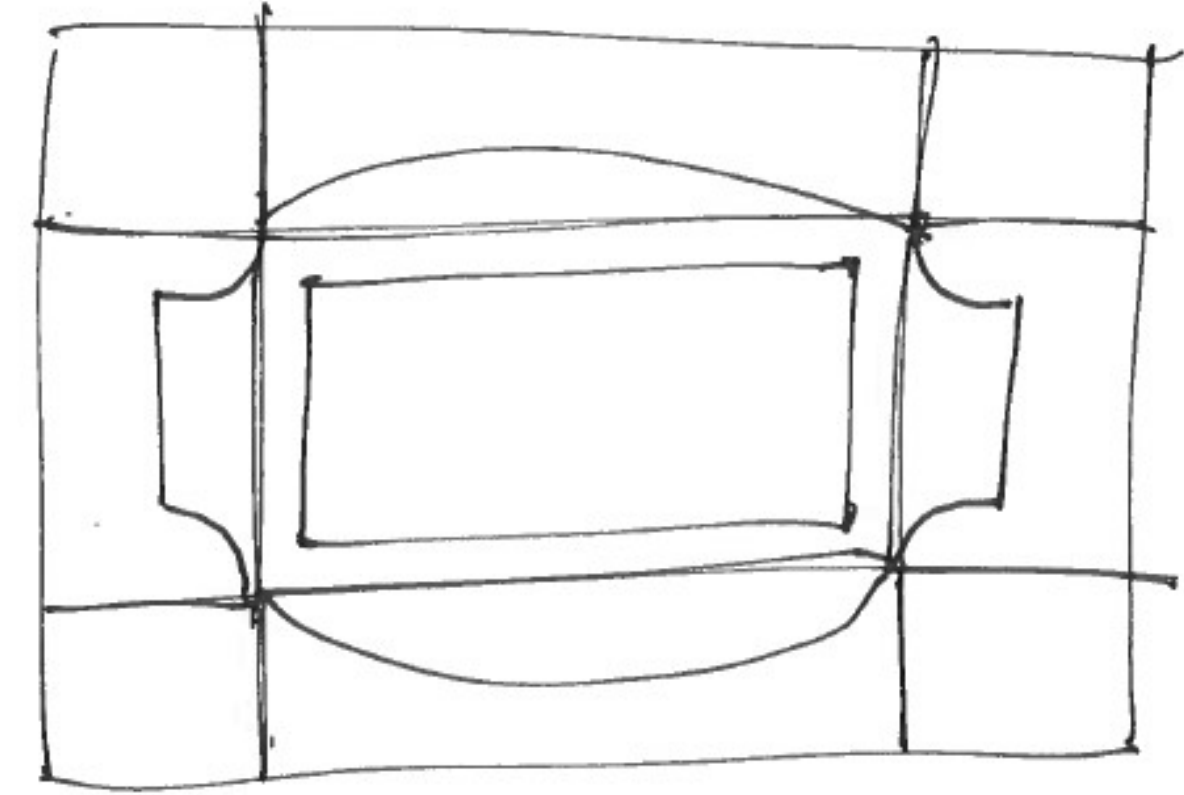
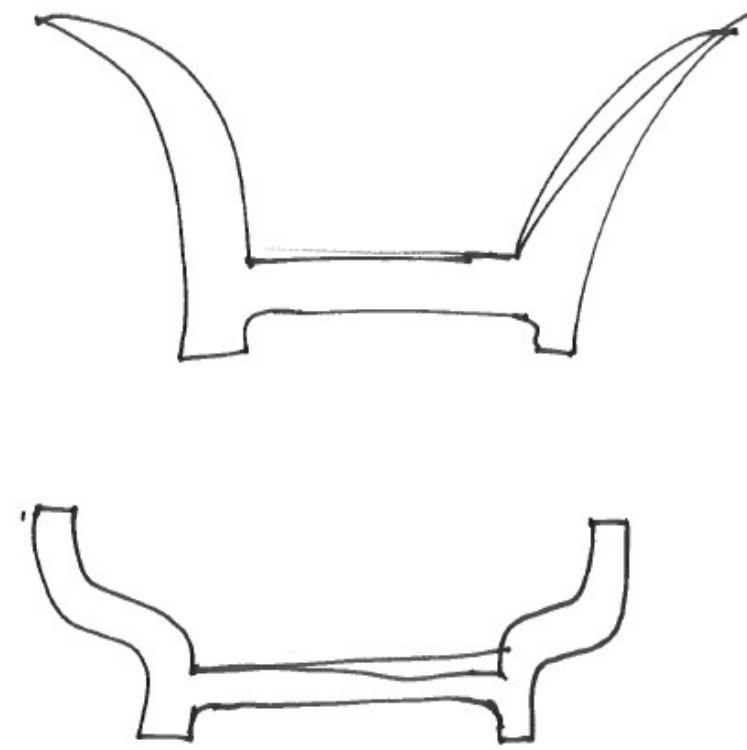

Edge variation  
1 system for all flat shapes

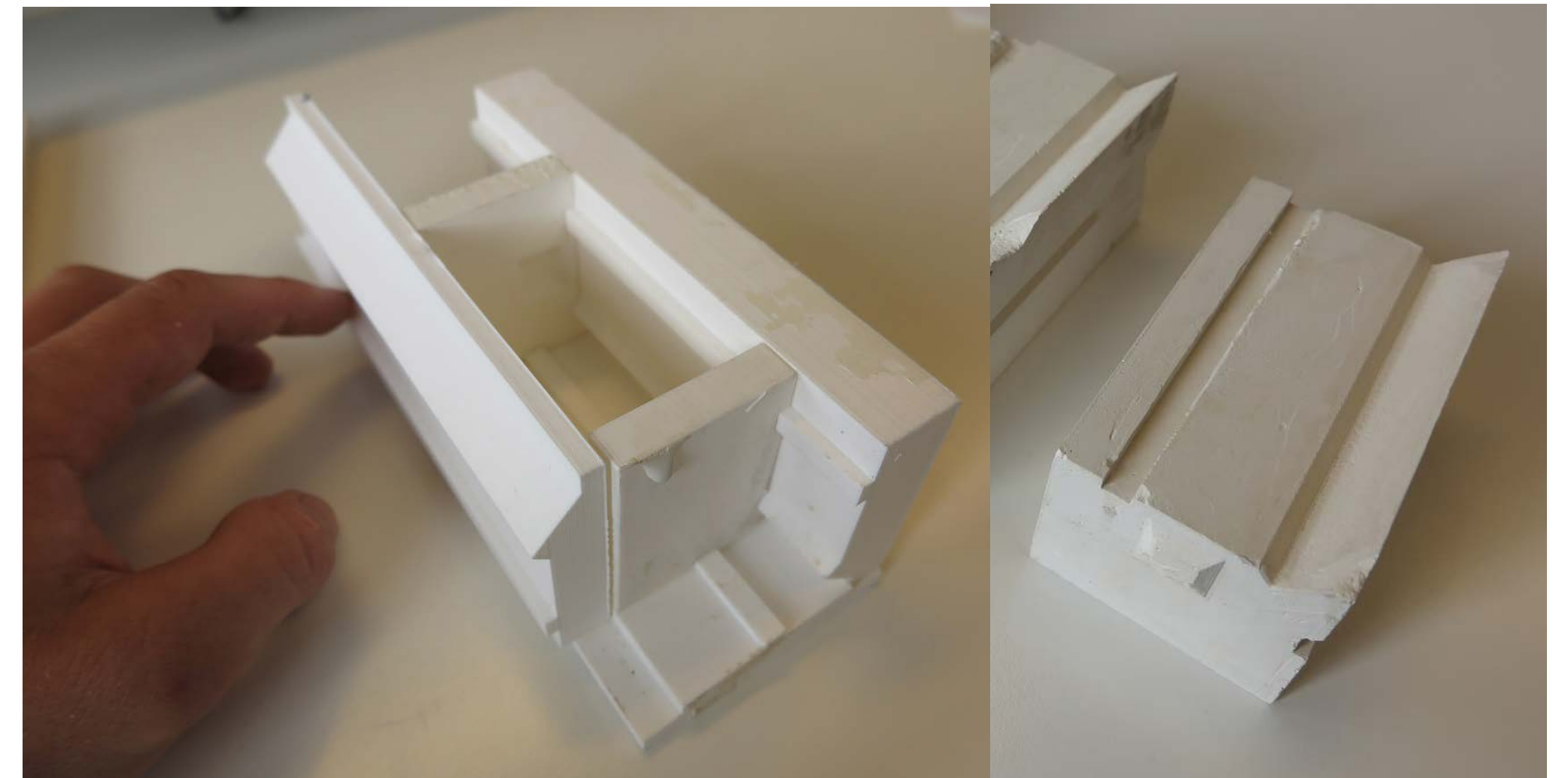



# Future stage 3: Inserts in 3D shapes

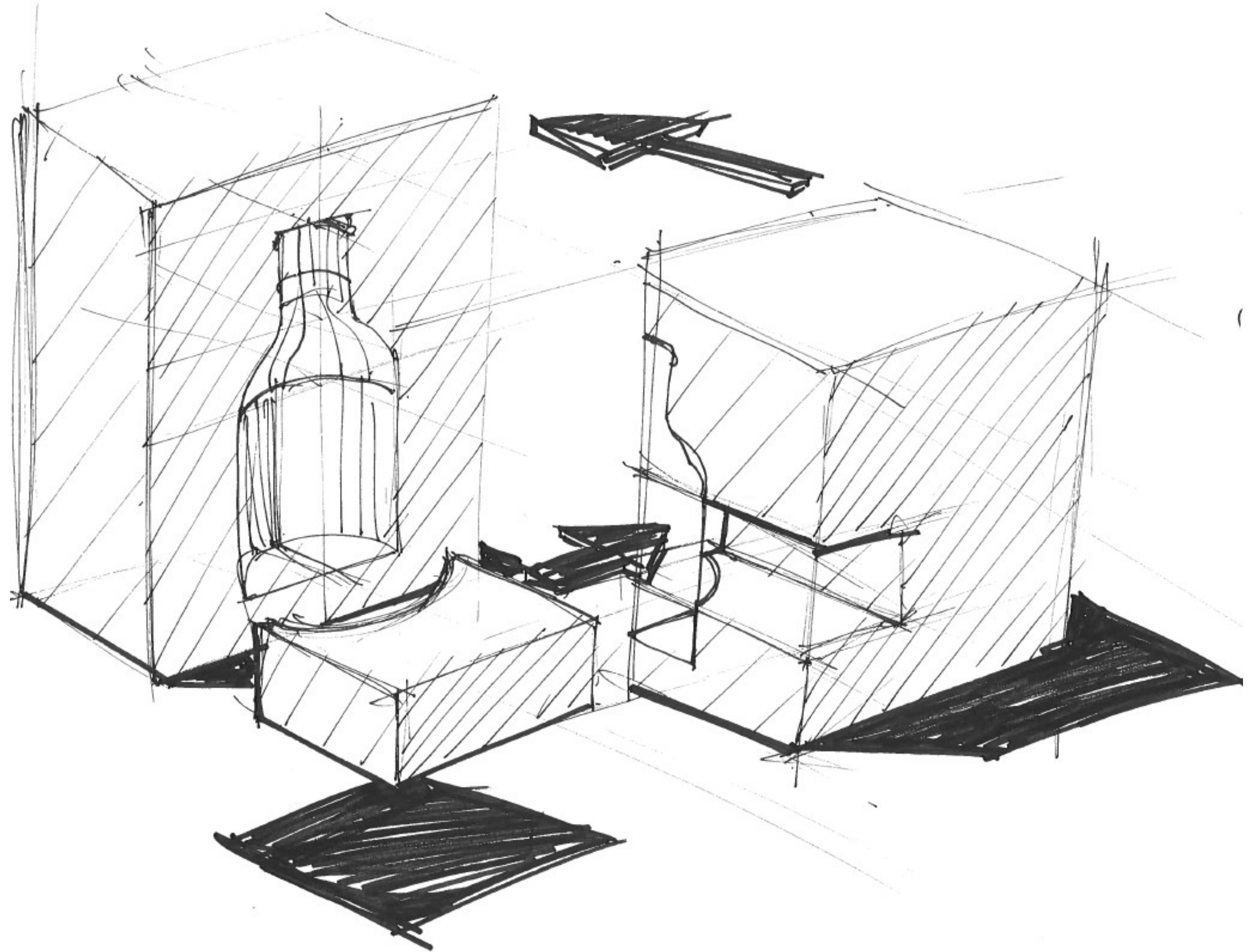
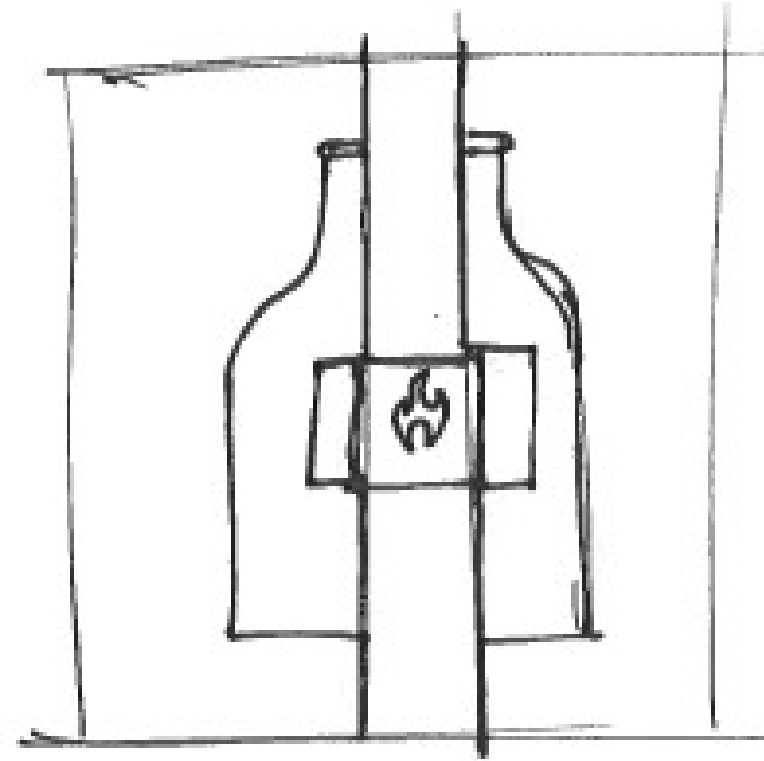



# Future stage 4: 2D to 3D

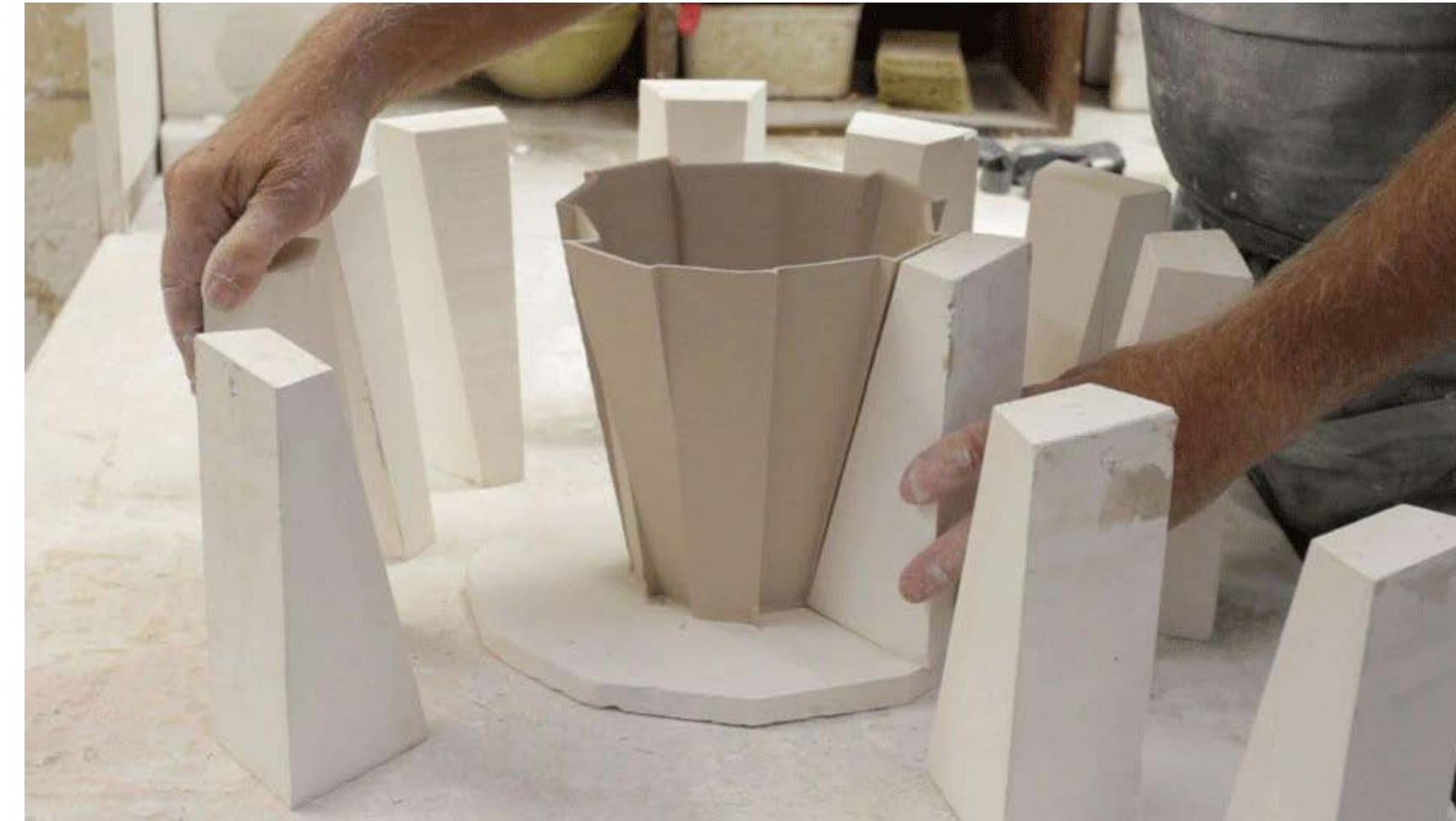
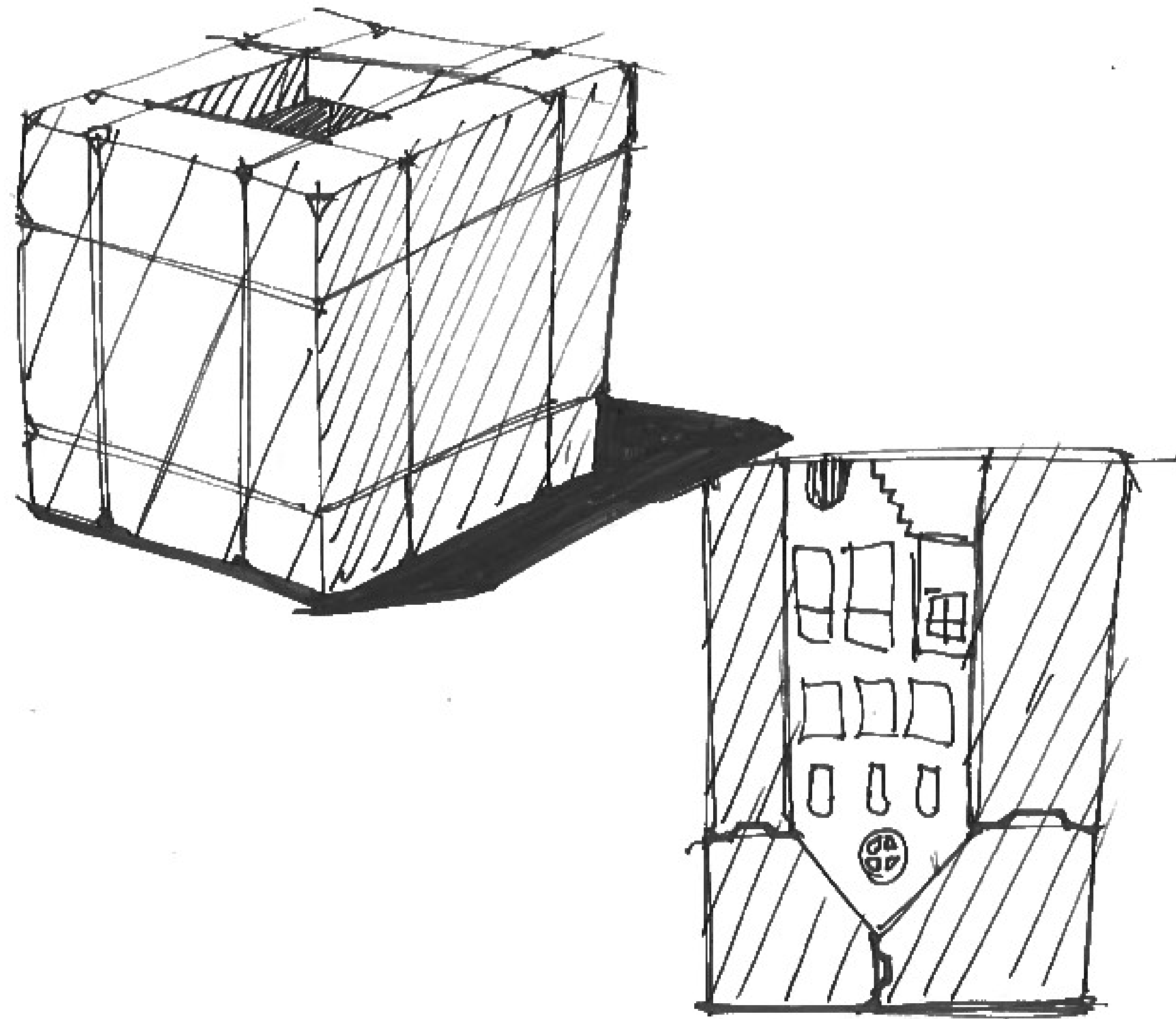



# Conclusion

## Production Approach

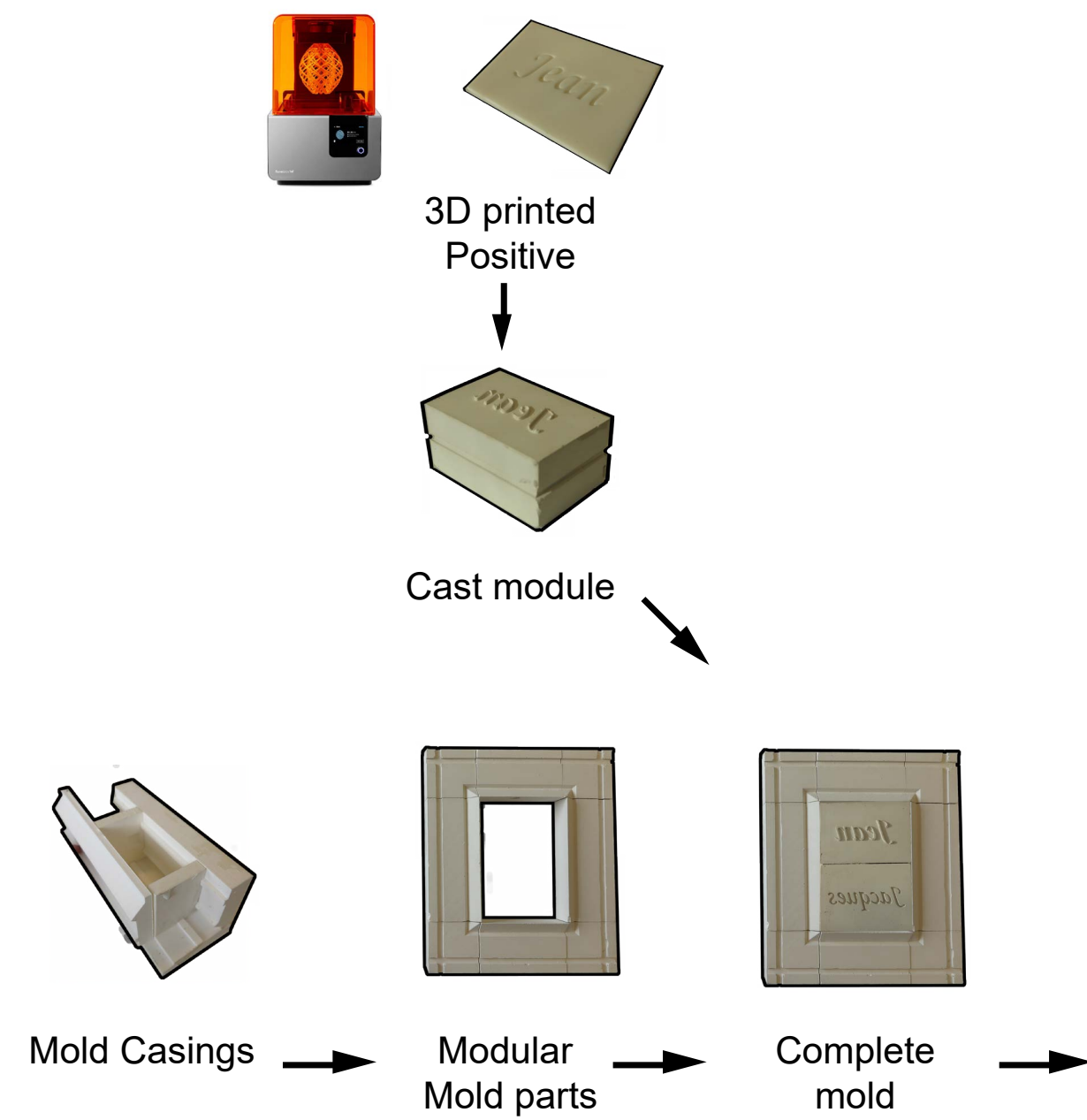

## Showcase Product

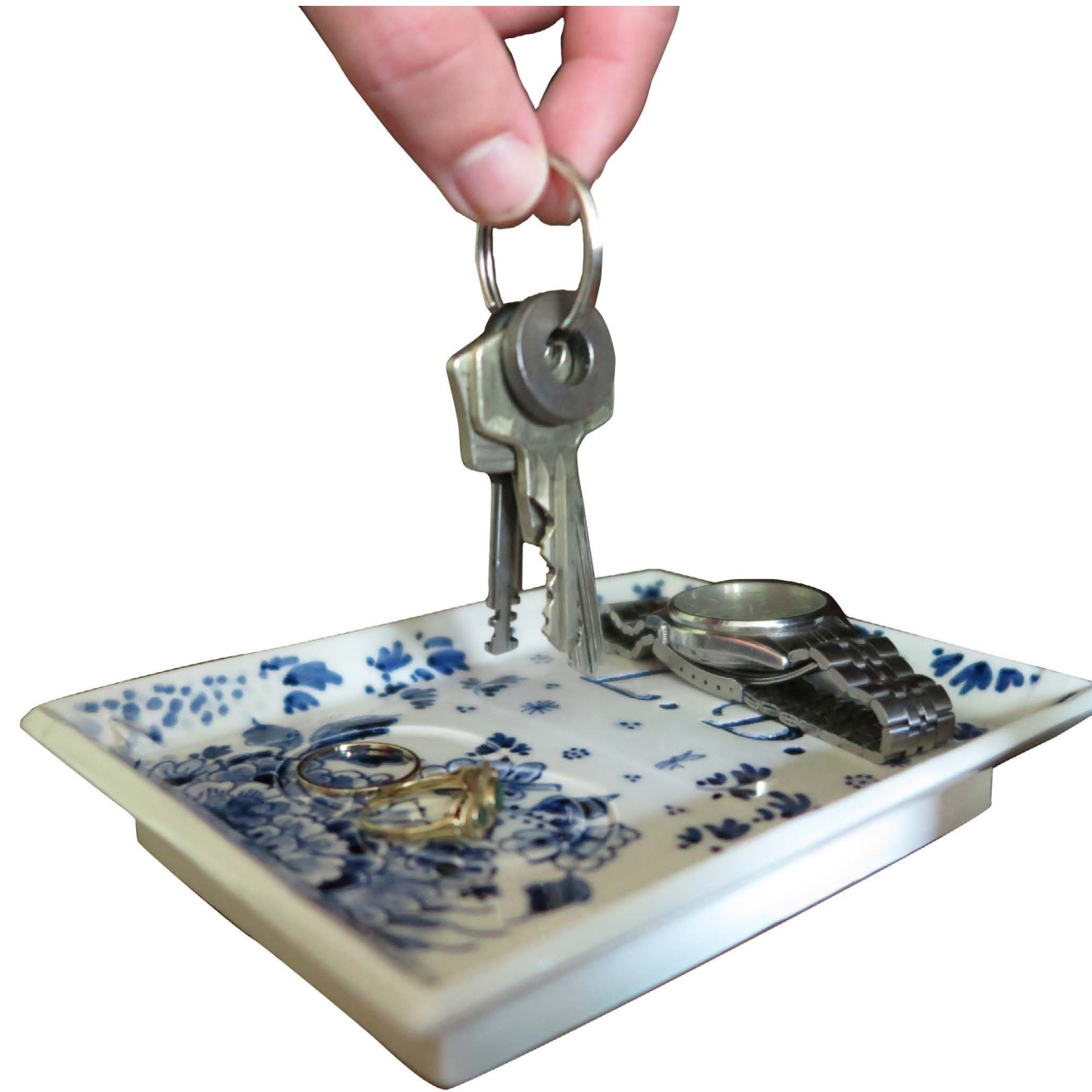

## Future Applications

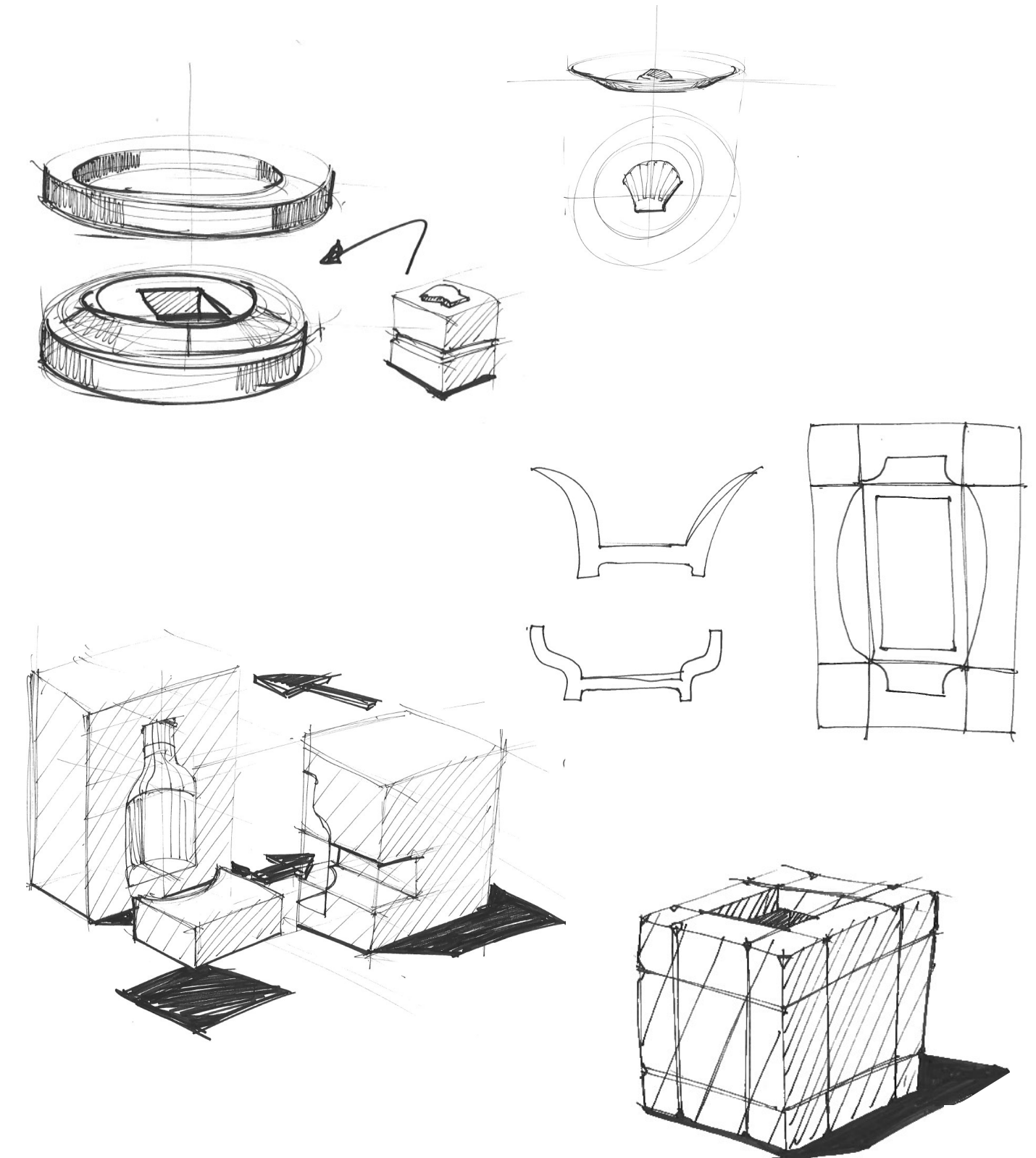





**Thank You**