

## Heritage Policy based Rehabilitation Scenarios

Limits of Acceptable Change of Heritage Housing in São Luís, Faro

**PART 1 INTRODUCTION**

**PART 2 RESEARCH**

**PART 3 DESIGN**

**PART 4 REFLECTION**

Algarve

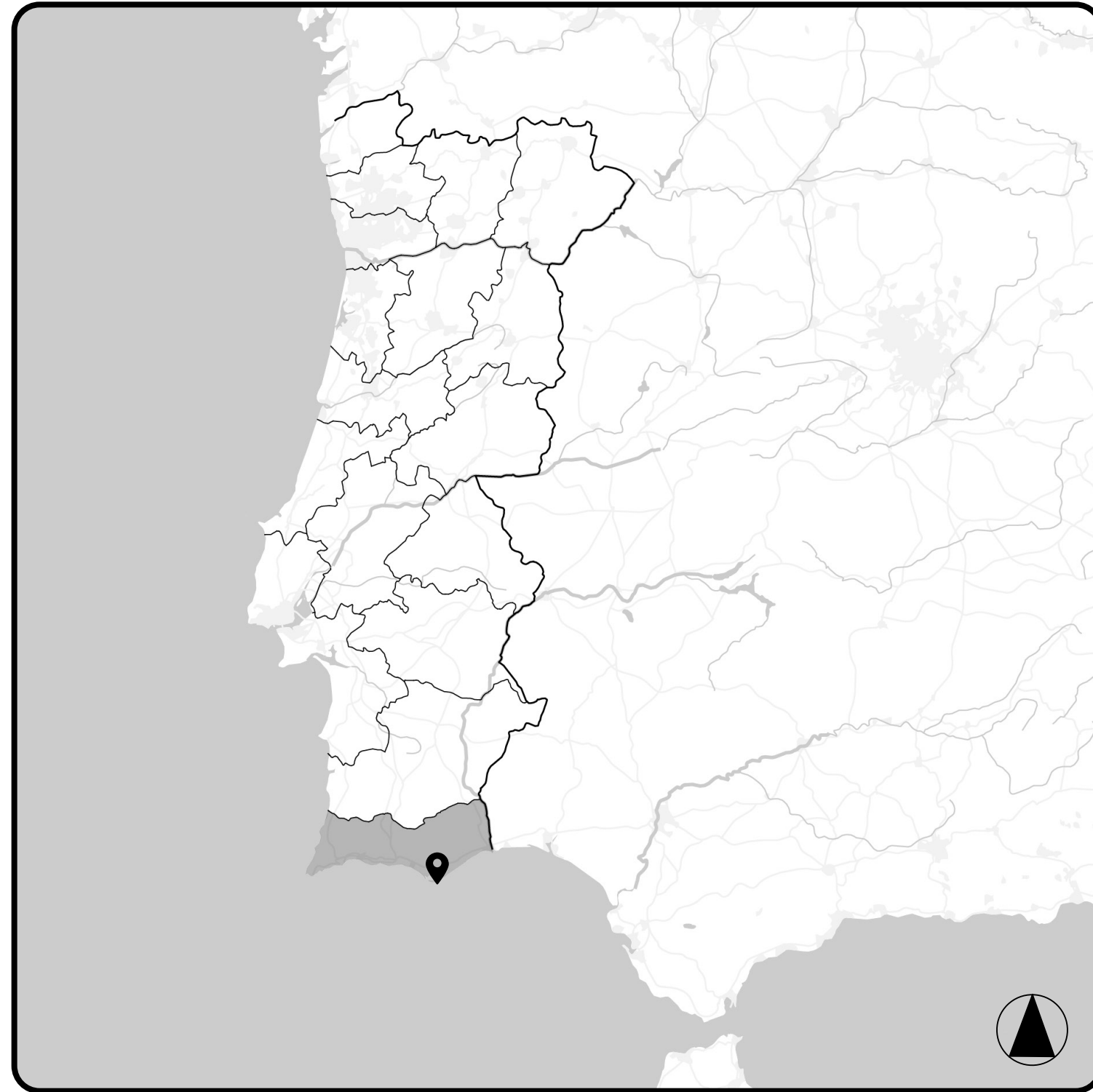

Faro

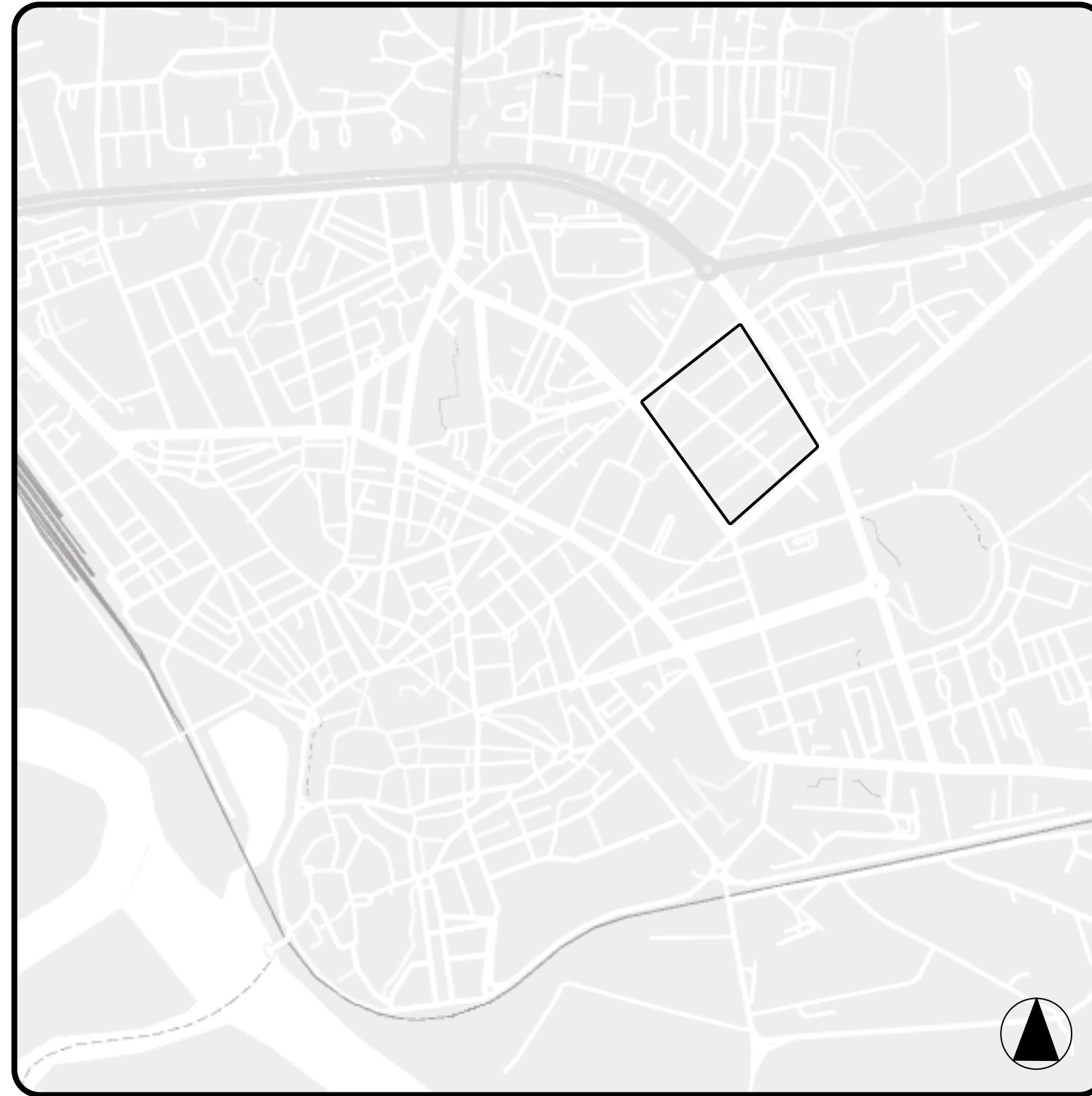

São Luís

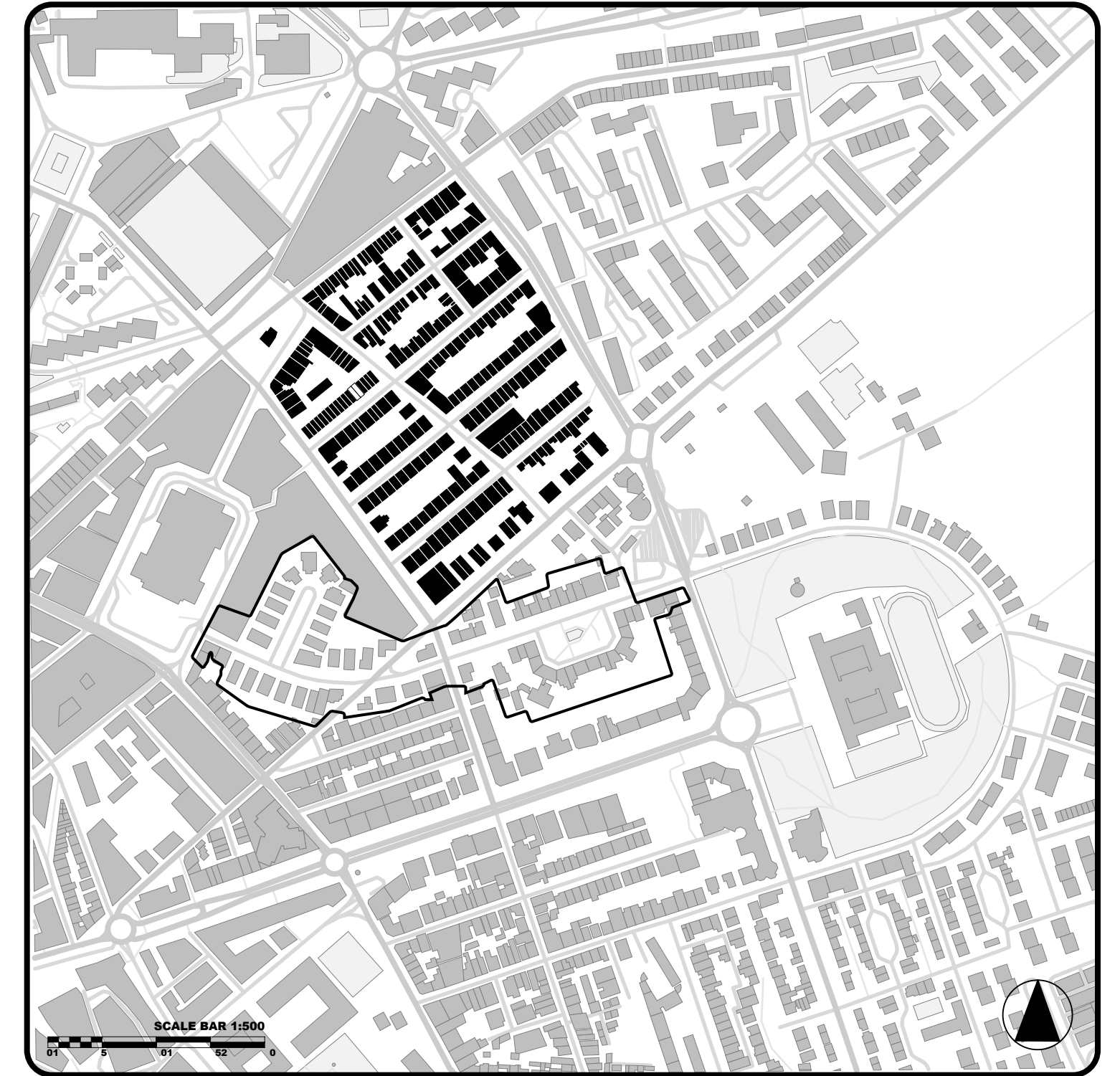

### Faro's Areas of Interest

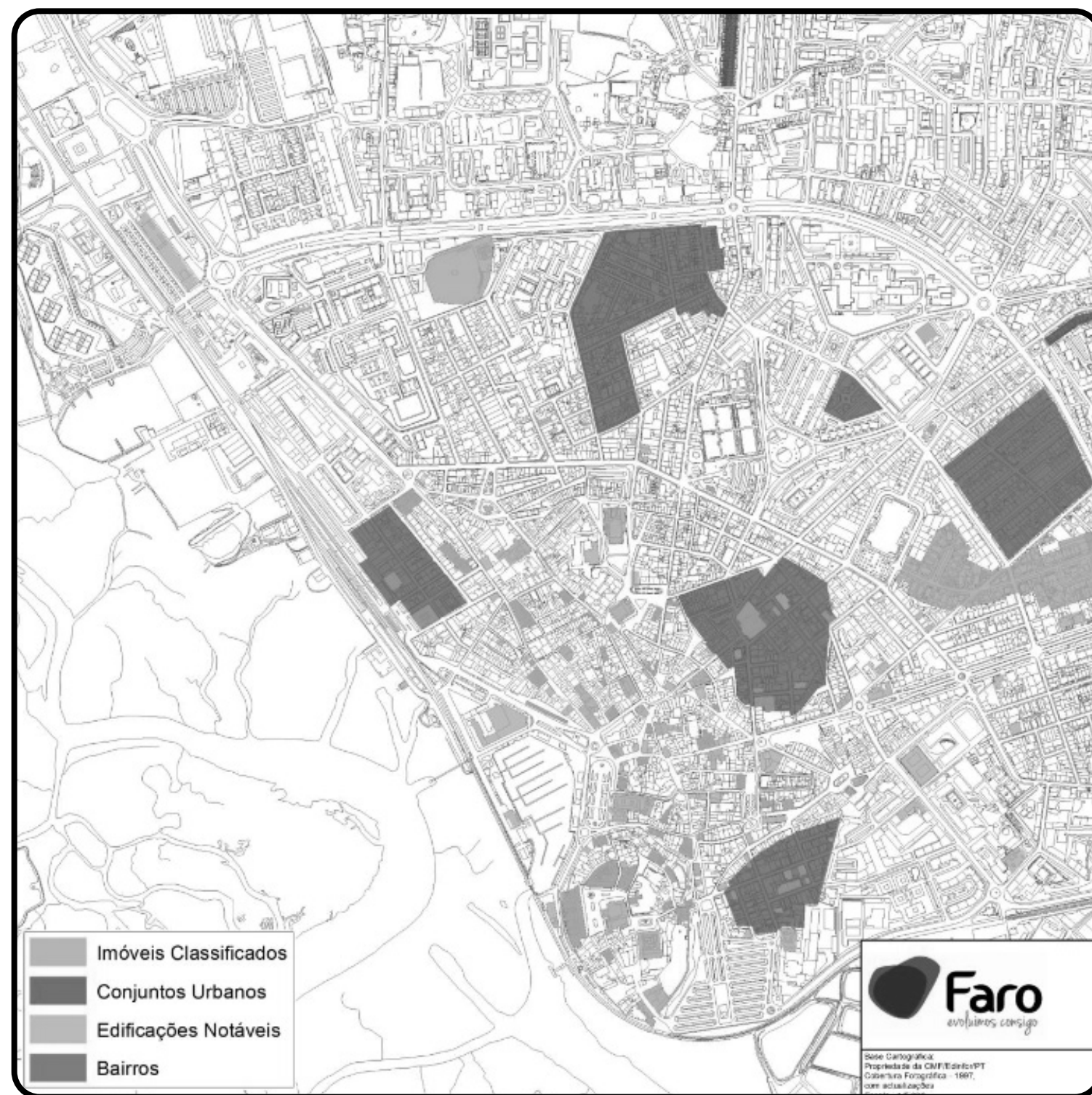

### Faro Convention



### Faro's Areas of Interest

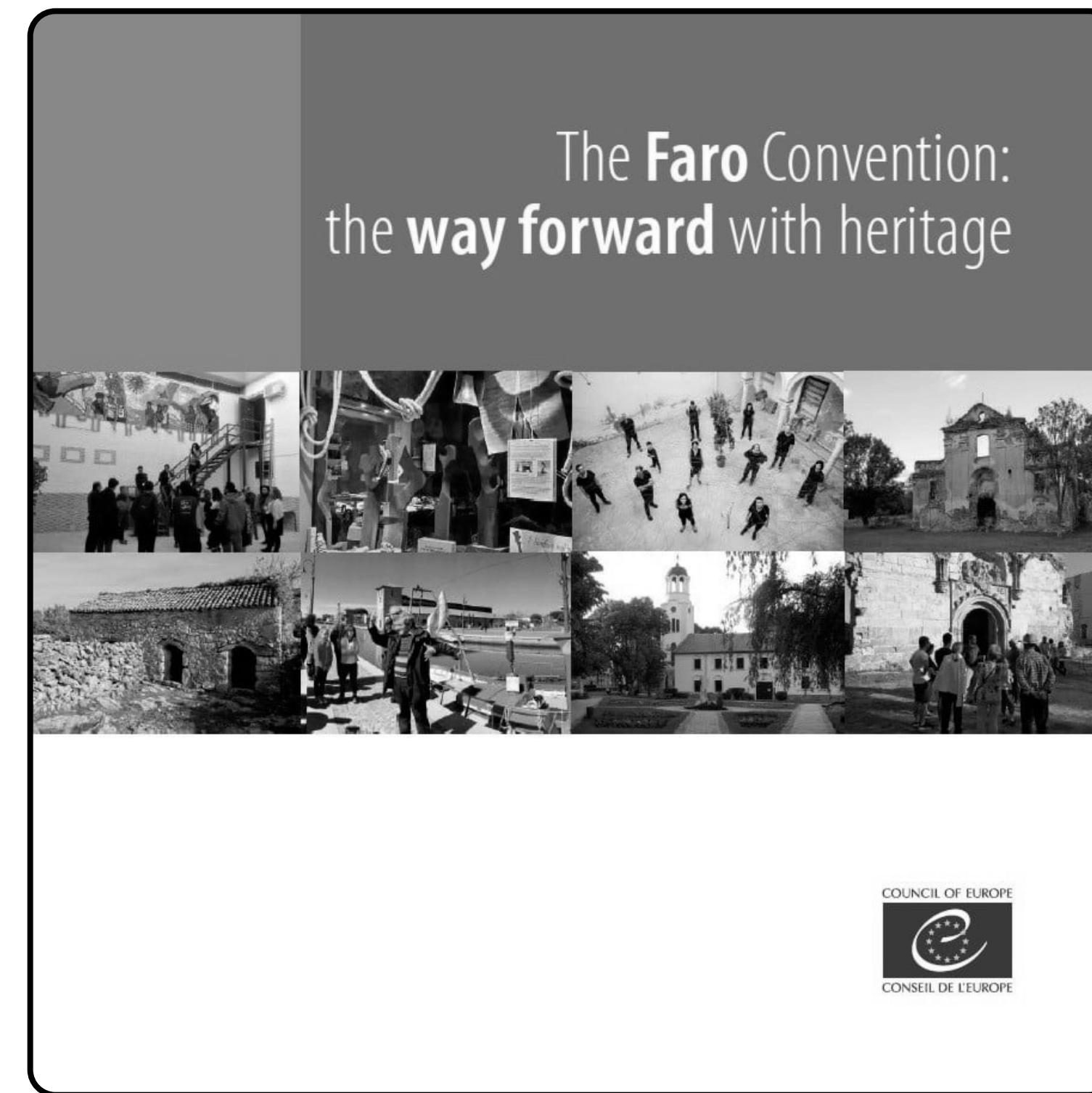

Roders, Interactive presentation, 2020

Lugar do Plano, "Revisão do Plano Director Municipal de Faro." 2021

MSc3 Revitalising Heritage: Faro Convention Labs, 2022

Council of Europe Framework Convention on the Value of Cultural Heritage for Society, 2005

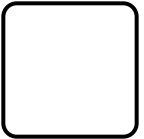

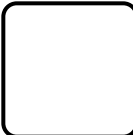

THEORETICAL FRAMEWORK FOR LIMITS  
OF ACCEPTABLE CHANGE

THEORETICAL FRAMEWORK FROM VELDPAUS

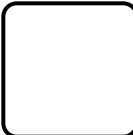

**WHICH**  
LIMITS OF  
ACCEPTABLE CHANGE







**WHY**  
VALUES

**WHAT**  
ATTRIBUTES

**WHO**  
STAKEHOLDERS

**HOW**  
PROCESS

**WHICH**  
LIMITS OF  
ACCEPTABLE CHANGE

 ADD	 KEEP	 REMOVE	
			 IDENTITY
			 SIMILARITY
			 DIFFERENCE

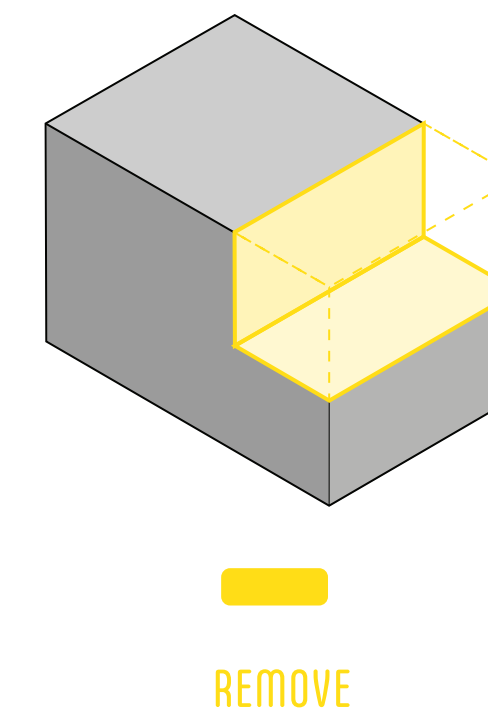
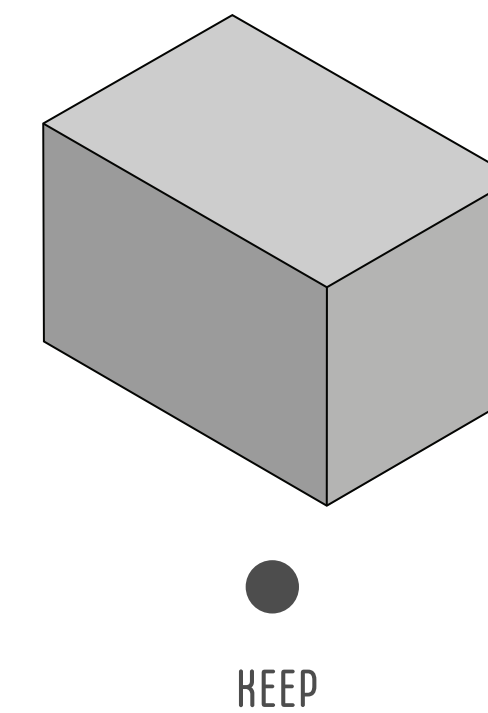
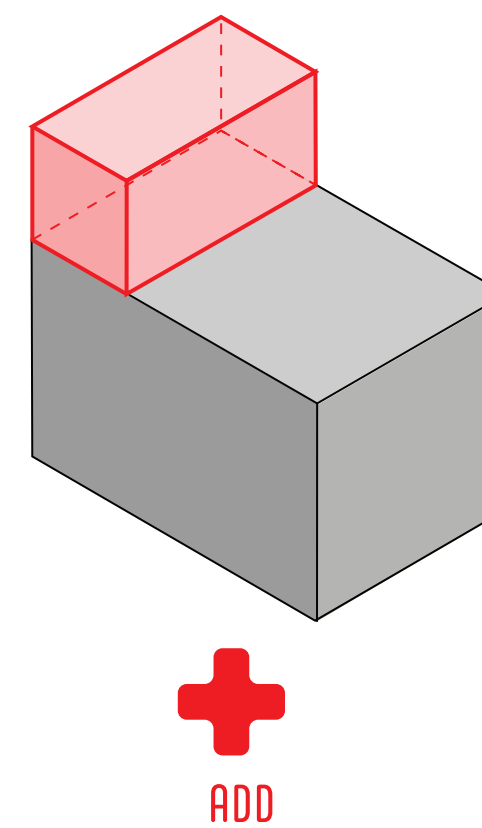
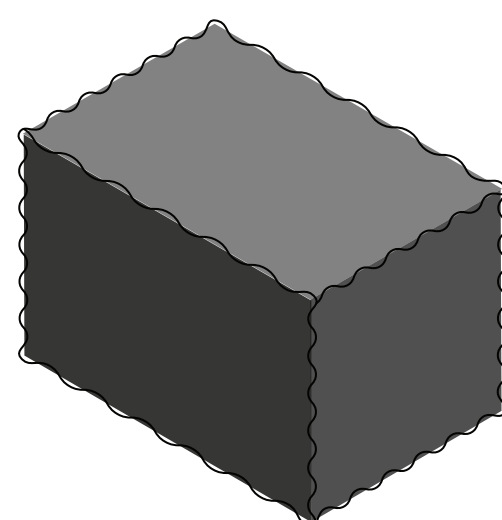
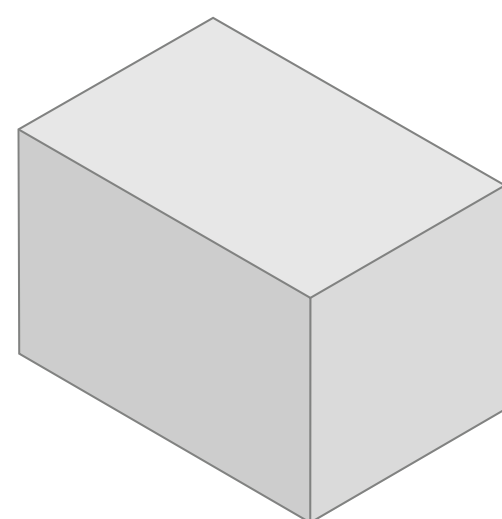

David Cole and Stephen McCool, "Limits of Acceptable Change and Natural Resources Planning: When is LAC Useful, When is it Not?," (01/011997).

Ana Pereira Roders, "Re-architecture : lifespan rehabilitation of built heritage" (PhD Technical University of Eindhoven, 2007), <https://doi.org/10.6100/IR631784>.

Turner, Tom. City as Landscape. London: E & FN Spon, 1996.

Turner, Tom. Landscape Planning and Environmental Impact Design. The Natural and Built Environment Series. Edited by Tom Editor. London: UCL Press Limited, 1998.



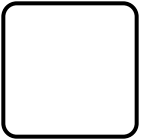

**WHICH**  
LIMITS OF  
ACCEPTABLE CHANGE



ADD



KEEP



REMOVE



IDENTITY



SIMILARITY



DIFFERENCE

**WHICH**  
LIMITS OF  
ACCEPTABLE CHANGE



ADD



KEEP

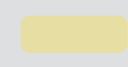

REMOVE

IDENTITY

SIMILARITY

DIFFERENCE

**WHY**  
VALUES

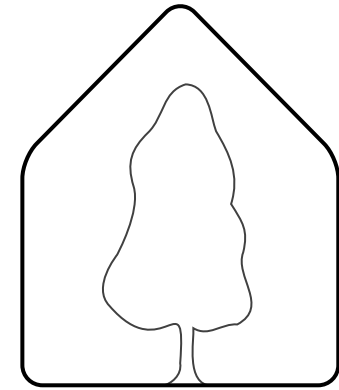

ECOLOGICAL

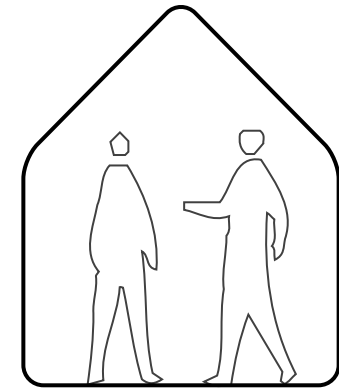

SOCIAL

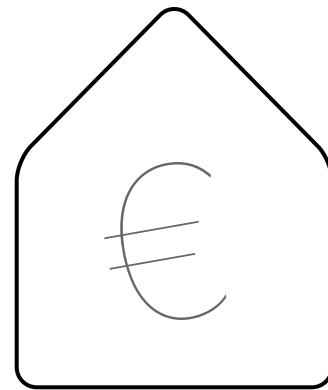

ECONOMIC

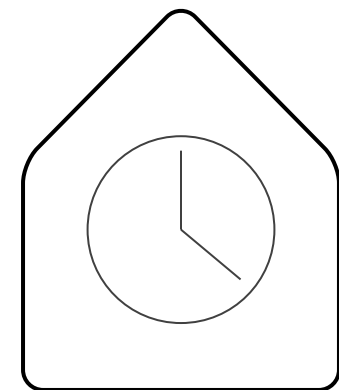

AGE

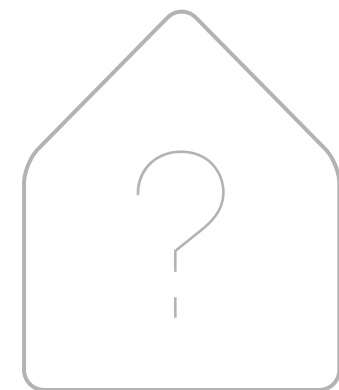

OTHER

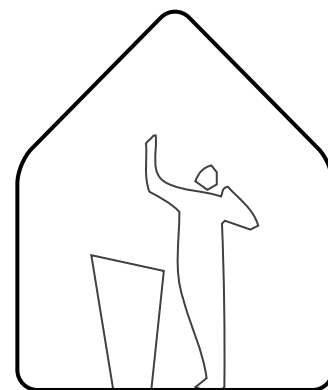

POLITICAL

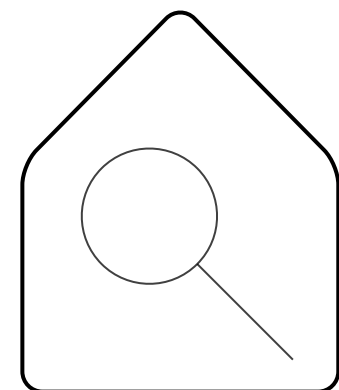

SCIENTIFIC

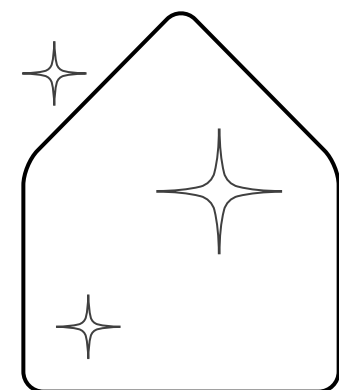

AEETHICAL

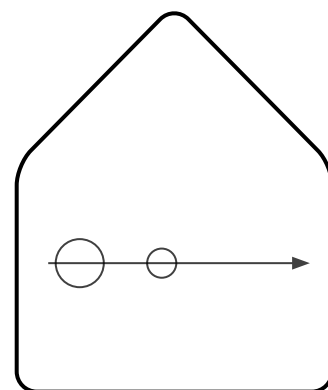

HISTORIC

**WHICH**  
LIMITS OF  
ACCEPTABLE CHANGE

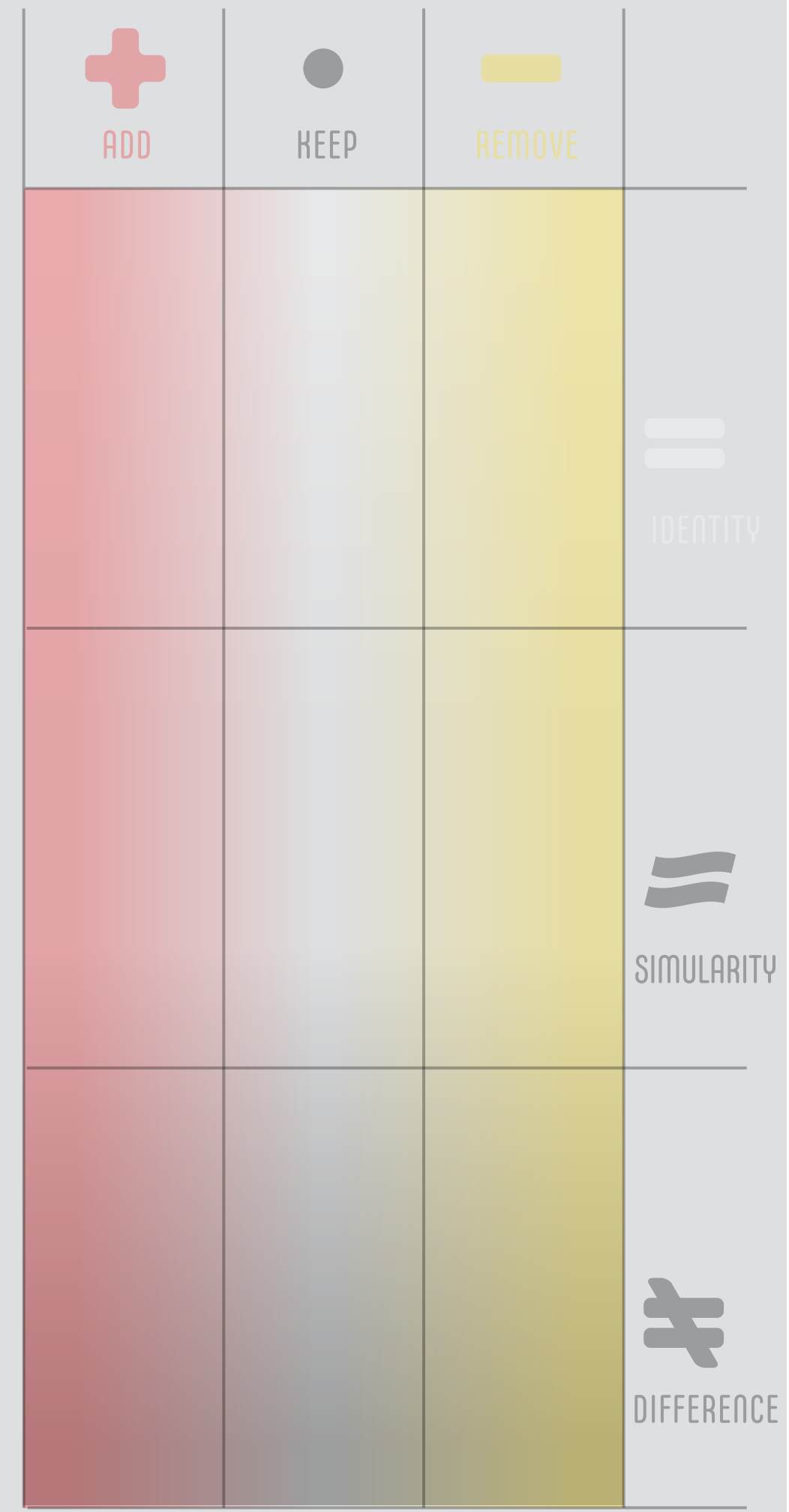

**WHY**  
VALUES

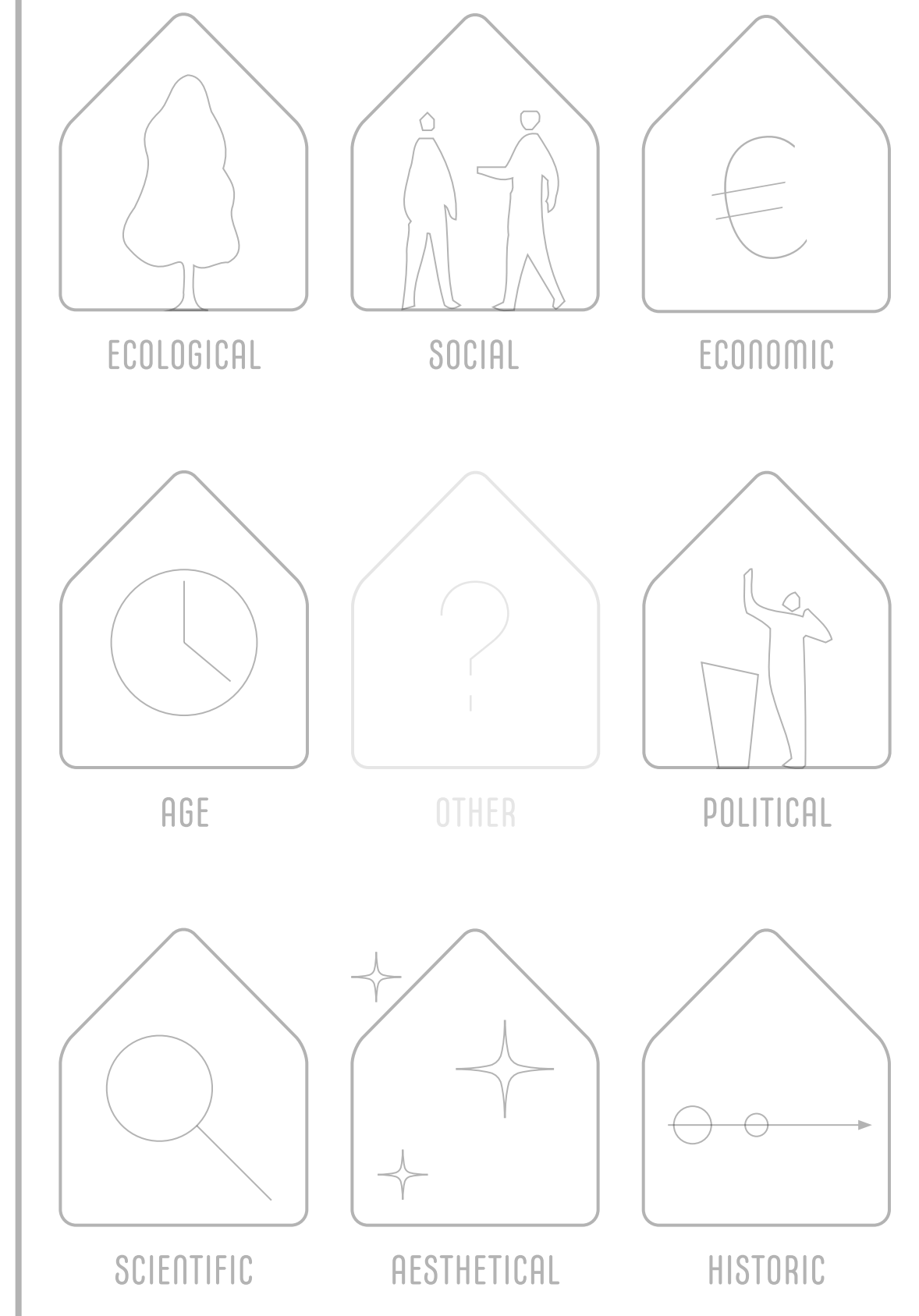

**WHAT**  
ATTRIBUTES

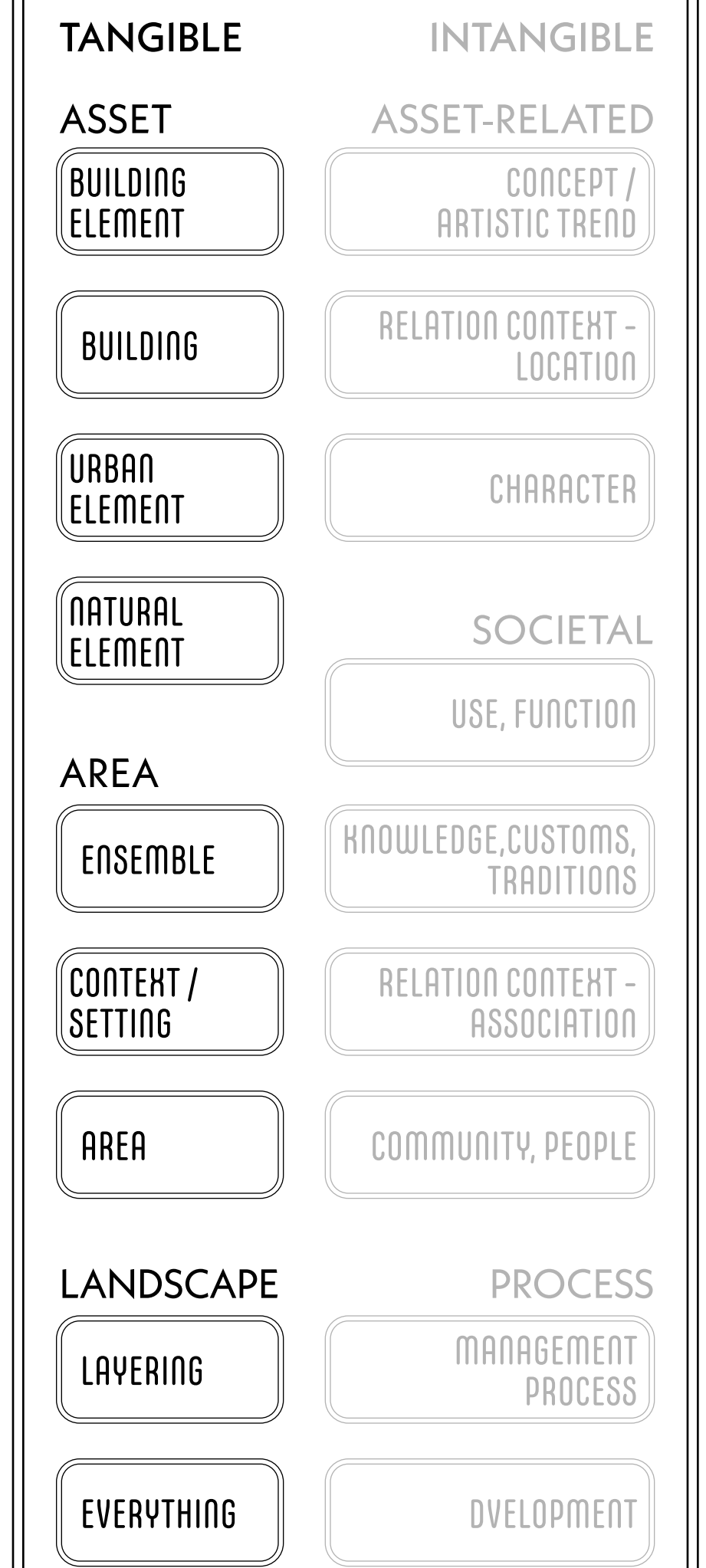

WHICH  
LIMITS OF  
ACCEPTABLE CHANGE



ADD



KEEP

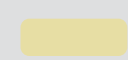

REMOVE

			=	IDENTITY		
					≡	SIMILARITY

WHY  
VALUES

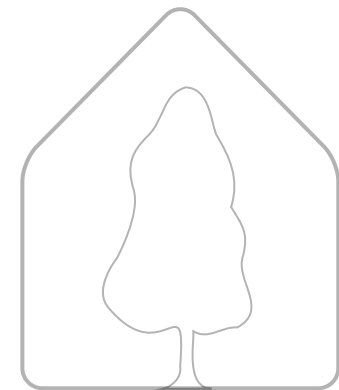

ECOLOGICAL

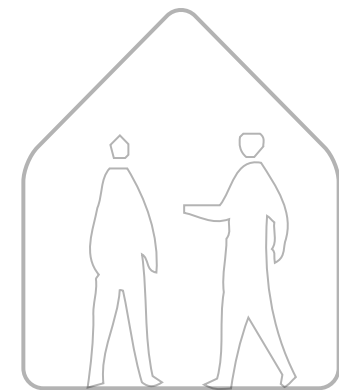

SOCIAL

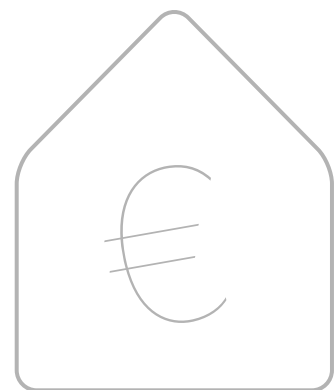

ECONOMIC

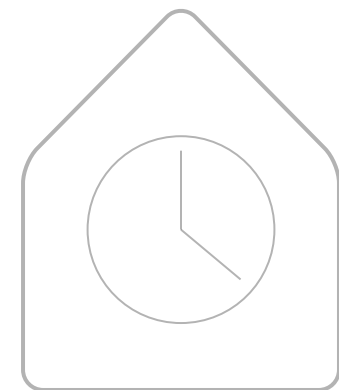

AGE



OTHER



POLITICAL

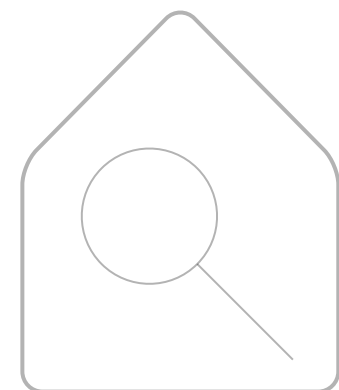

SCIENTIFIC

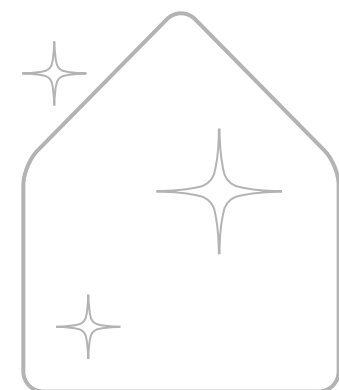

AESTHETICAL

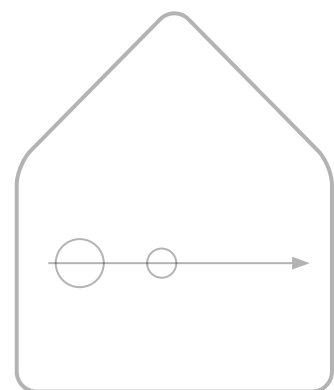

HISTORIC

WHAT  
ATTRIBUTES

TANGIBLE

ASSET

BUILDING ELEMENT

BUILDING

URBAN ELEMENT

NATURAL ELEMENT

AREA

ENSEMBLE

CONTEXT / SETTING

AREA

LANDSCAPE

LAYERING

EVERYTHING

WHO  
STAKEHOLDERS

GOVERNMENTAL

POLITICIANS

POLICY MAKERS

OFFICERS

EXPERTS

SCIENTIFIC

PROFESSIONAL

NON-PROFESSIONAL

COMMUNITY

PRIVATE SECTOR

DIRECTLY INVOLVED

INDIRECTLY INVOLVED

WHICH  
LIMITS OF  
ACCEPTABLE CHANGE



ADD



KEEP

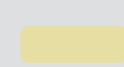

REMOVE

			=	IDENTITY		
					≡	SIMILARITY

WHY  
VALUES

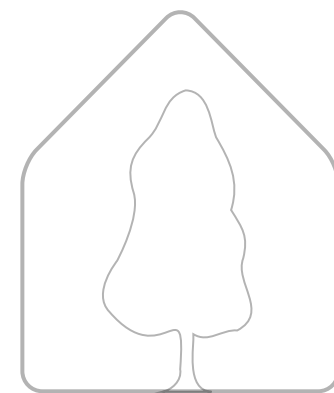

ECOLOGICAL

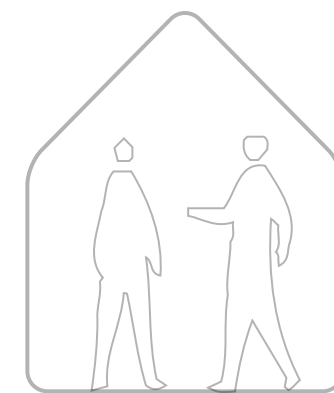

SOCIAL

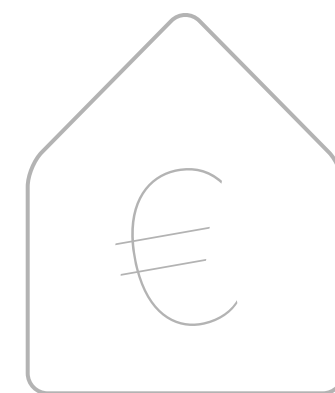

ECONOMIC

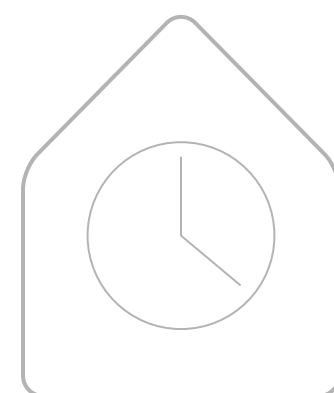

AGE



OTHER



POLITICAL

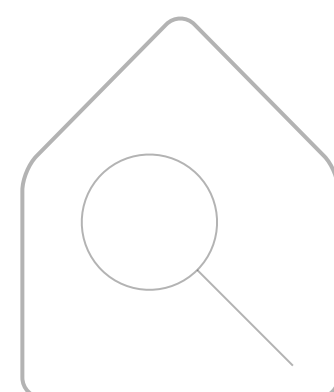

SCIENTIFIC

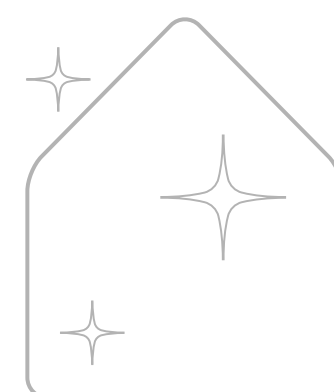

AESTHETICAL

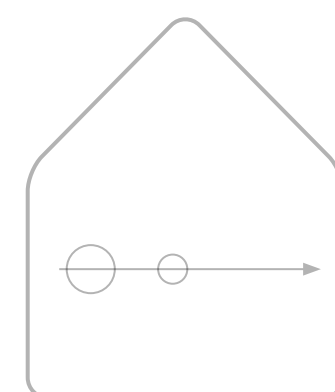

HISTORIC

WHAT  
ATTRIBUTES

TANGIBLE

ASSET

BUILDING ELEMENT

BUILDING

URBAN ELEMENT

NATURAL ELEMENT

AREA

ENSEMBLE

CONTEXT / SETTING

AREA

LANDSCAPE

LAYERING

EVERYTHING

WHO  
STAKEHOLDERS

SPECIALISTS



COMMUNITY

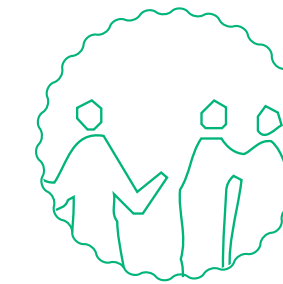

WHICH  
LIMITS OF  
ACCEPTABLE CHANGE



ADD



KEEP

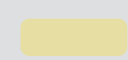

REMOVE

IDENTITY

SIMILARITY

DIFFERENCE

WHY  
VALUES

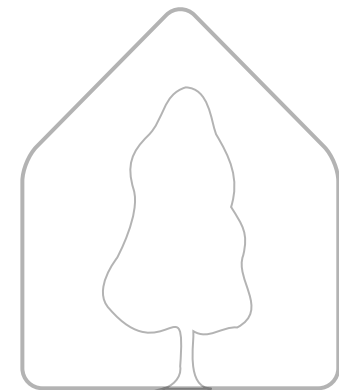

ECOLOGICAL

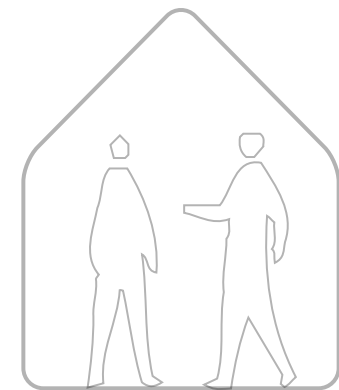

SOCIAL

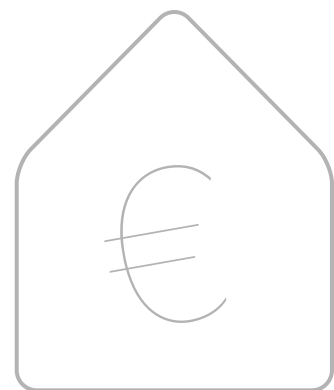

ECONOMIC

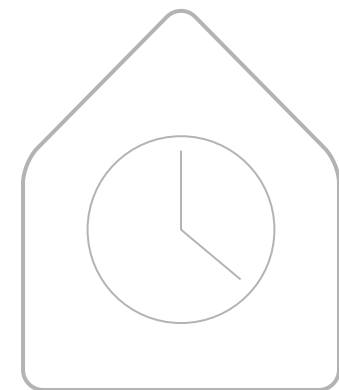

AGE



OTHER



POLITICAL

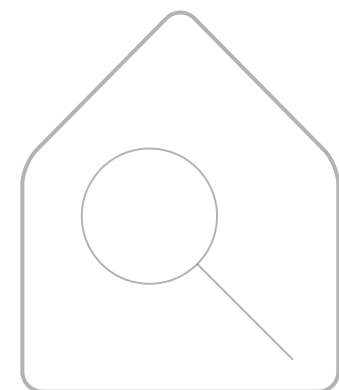

SCIENTIFIC

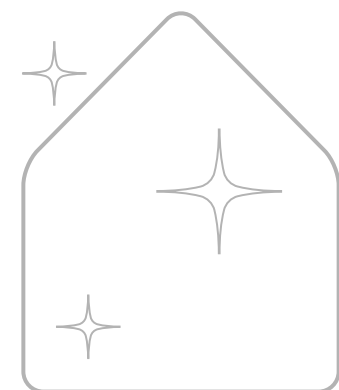

AESTHETICAL

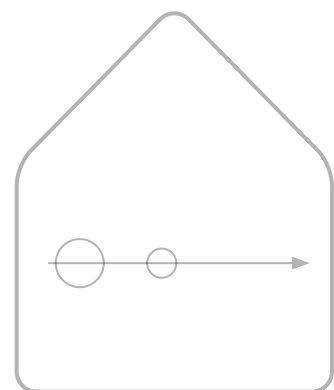

HISTORIC

WHAT  
ATTRIBUTES

TANGIBLE

ASSET

BUILDING  
ELEMENT

BUILDING

URBAN  
ELEMENT

NATURAL  
ELEMENT

AREA

ENSEMBLE

CONTEXT /  
SETTING

AREA

LANDSCAPE

LAYERING

EVERYTHING

WHO  
STAKEHOLDERS

SPECIALISTS



COMMUNITY



HOW  
PROCESS

A CONTEXT

INVENTORY

ANALYSE

DEFINE SIGNIFICANCE

B STRATEGY

BUILDING ANALYSIS

DEVELOP STRATEGY

INTEGRATE

C MANAGE

PRIORITIZE

PROCESS REFLECTION

WHICH  
LIMITS OF  
ACCEPTABLE CHANGE



ADD



KEEP

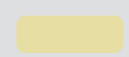

REMOVE

=  
IDENTITY

≈  
SIMILARITY

≠  
DIFFERENCE

WHY  
VALUES

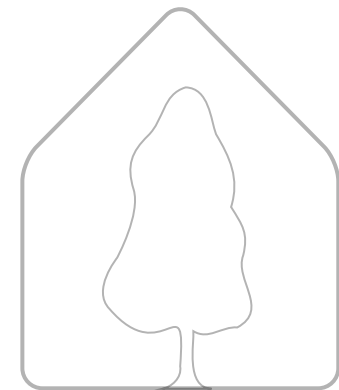

ECOLOGICAL

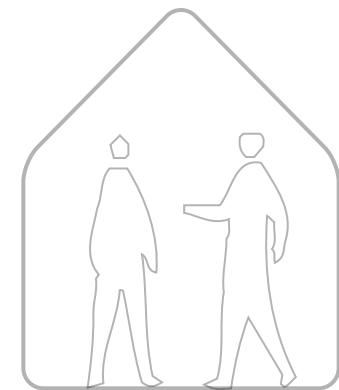

SOCIAL

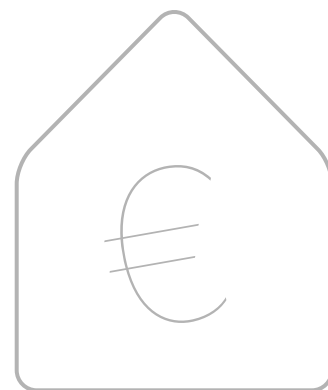

ECONOMIC

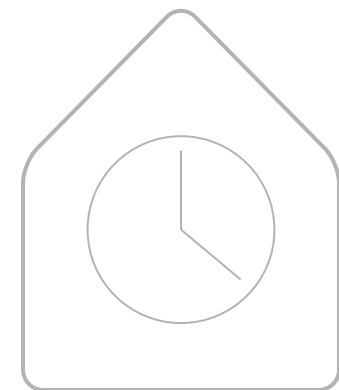

AGE

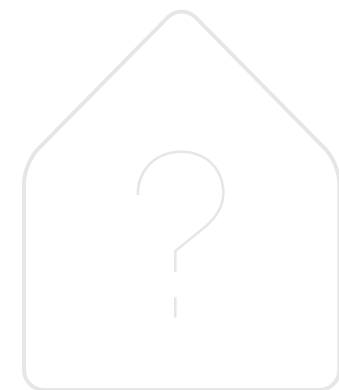

OTHER



POLITICAL

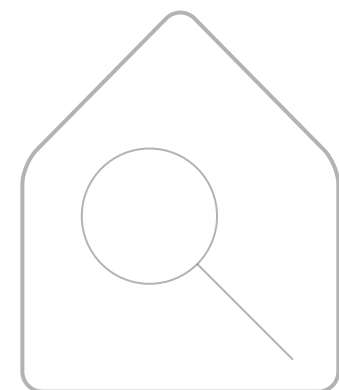

SCIENTIFIC

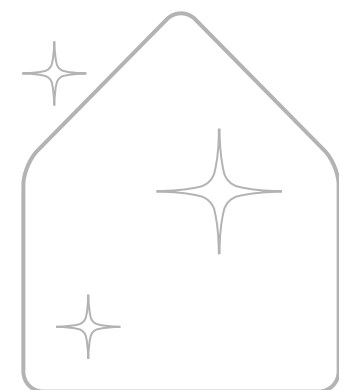

AESTHETICAL

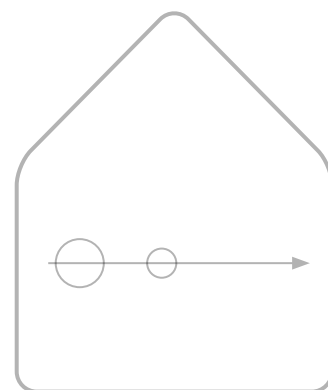

HISTORIC

WHAT  
ATTRIBUTES

TANGIBLE

ASSET

BUILDING  
ELEMENT

BUILDING

URBAN  
ELEMENT

NATURAL  
ELEMENT

AREA

ENSEMBLE

CONTEXT /  
SETTING

AREA

LANDSCAPE

LAYERING

EVERYTHING

WHO  
STAKEHOLDERS

SPECIALISTS



COMMUNITY



HOW  
PROCESS

A CONTEXT

INVENTORY & ANALYSE

DEFINE SIGNIFICANCE

DEFINE AFFECTING FACTORS

B STRATEGY

BUILDING ANALYSIS

DEVELOP STRATEGY

INTEGRATE

C MANAGE

PRIORITIZE

PROCESS REFLECTION

GOAL

PRODUCT

METHODS

METHODOLOGY

# PART 1 INTRODUCTION

# PART 2 RESEARCH



# A CONTEXT

A1 INVENTORY

A2 ANALYSIS

A3 DEFINE SIGNIFICANCE

# PART 3 DESIGN

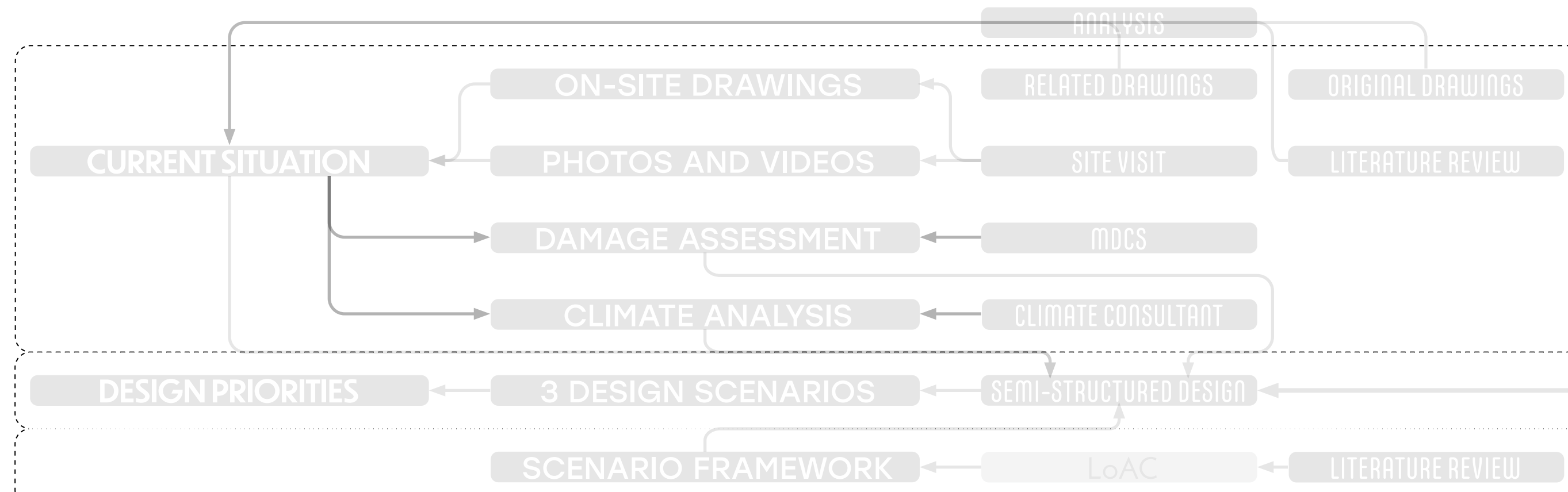

# B STRATEGY

B1 BUILDING ANALYSIS

B2 DEVELOP STRATEGY

B3 INTEGRATE

# PART 4 REFLECTION



# C MANAGE

C1 PRIORITIZE

C2 PROCESS REFLECTION



PART 1 INTRODUCTION

**PART 2 RESEARCH**

PART 3 DESIGN

PART 4 REFLECTION

GOAL

PRODUCT

METHODS

METHODOLOGY

# PART 1 INTRODUCTION

## PART 2 RESEARCH

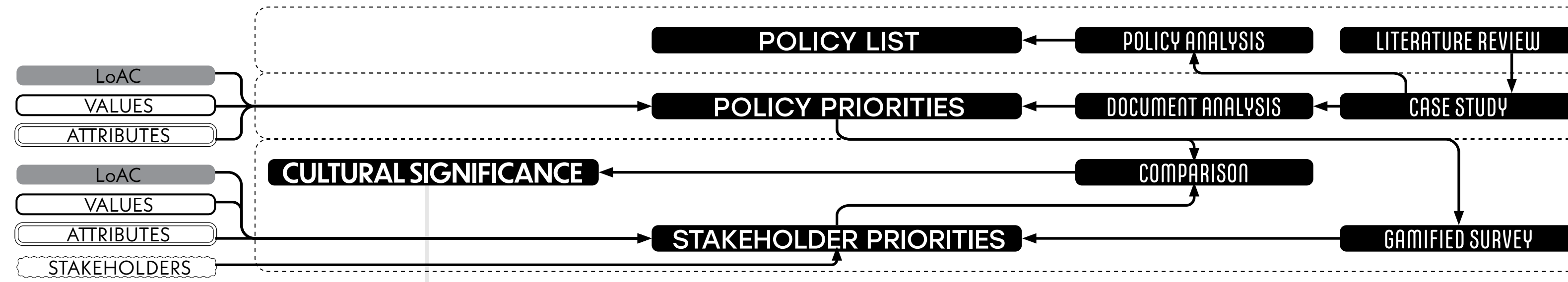

## A CONTEXT

A1 INVENTORY

A2 ANALYSIS

A3 DEFINE SIGNIFICANCE

## PART 3 DESIGN

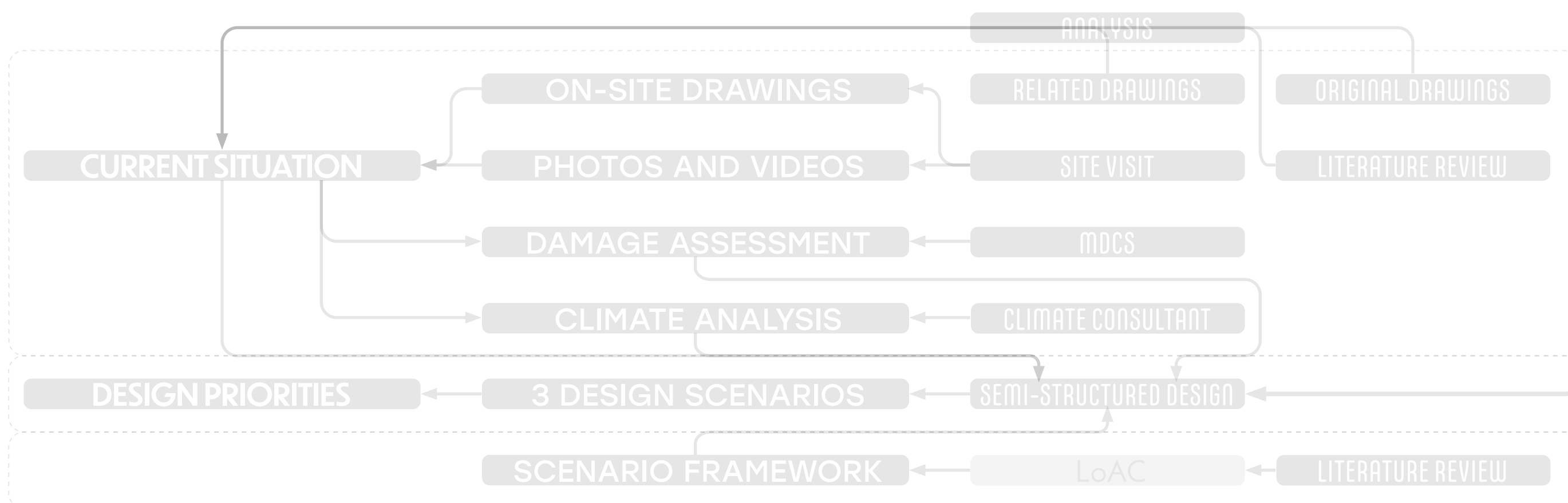

## B STRATEGY

B1 BUILDING ANALYSIS

B2 DEVELOP STRATEGY

B3 INTEGRATE

## PART 4 REFLECTION



## C MANAGE

C1 PRIORITIZE

C2 PROCESS REFLECTION

GOAL

PRODUCT

METHODS

METHODOLOGY

# PART 1 INTRODUCTION

## PART 2 RESEARCH

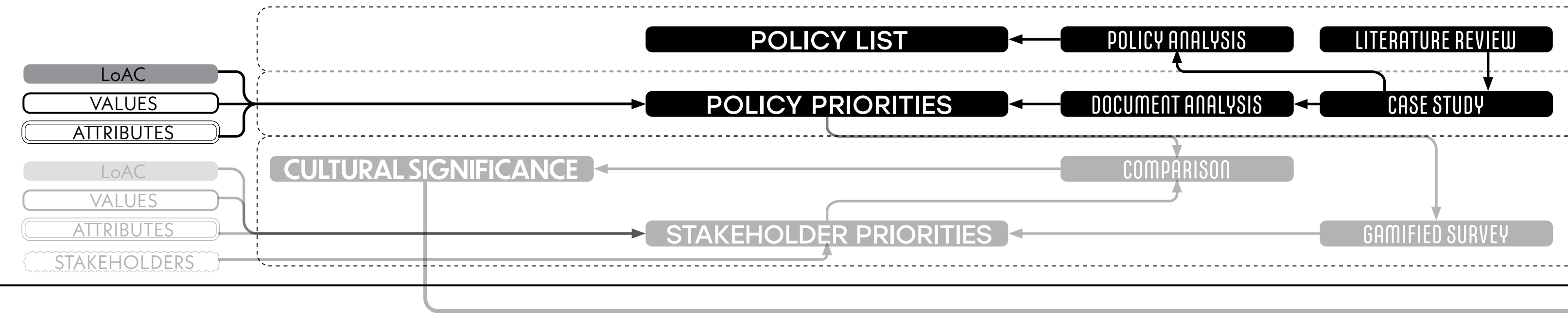

## A CONTEXT

A1 INVENTORY

A2 ANALYSIS

A3 DEFINE SIGNIFICANCE

## PART 3 DESIGN

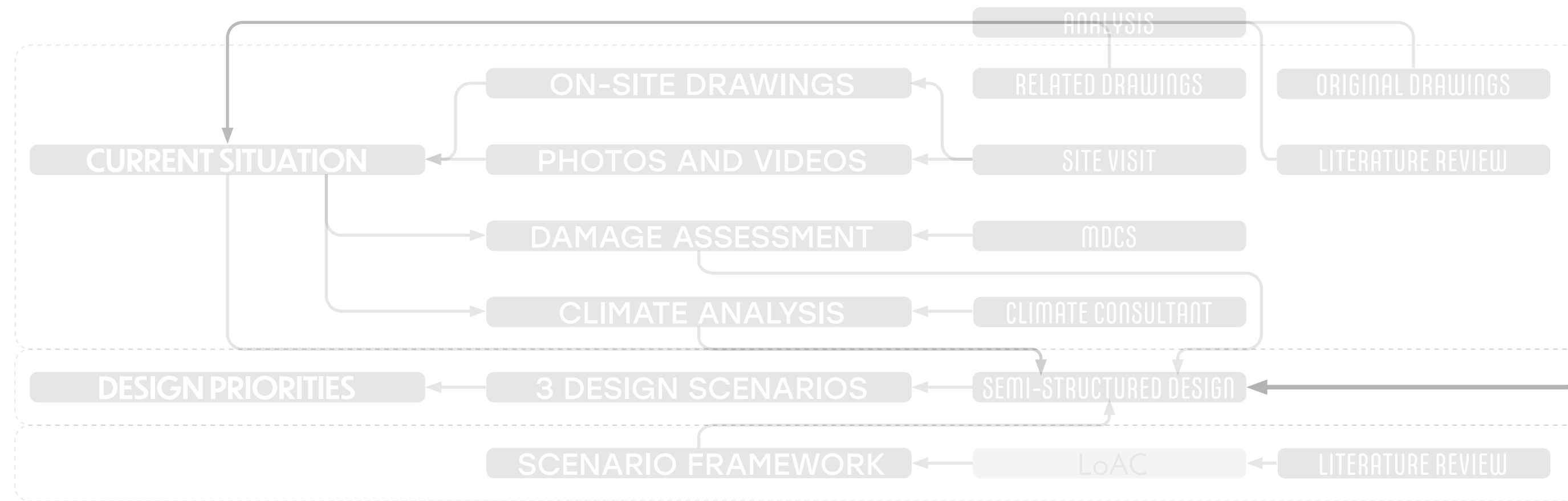

## B STRATEGY

B1 BUILDING ANALYSIS

B2 DEVELOP STRATEGY

B3 INTEGRATE

## PART 4 REFLECTION



## C MANAGE

C1 PRIORITIZE

C2 PROCESS REFLECTION

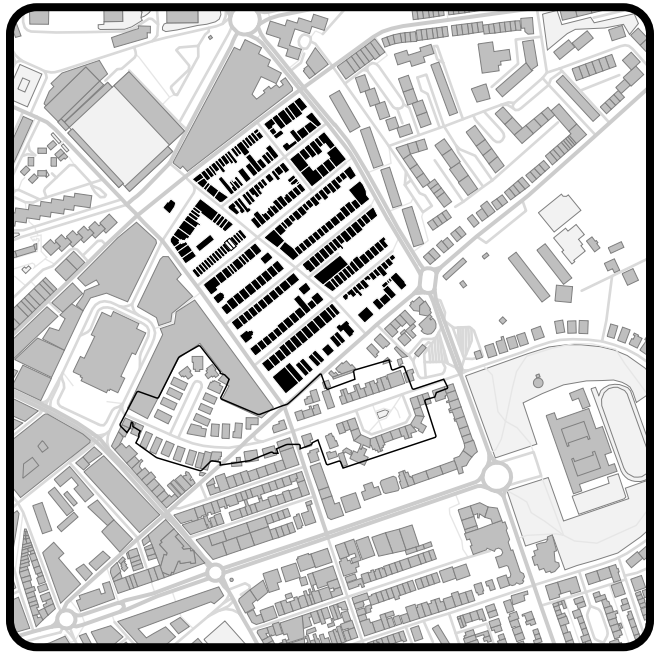
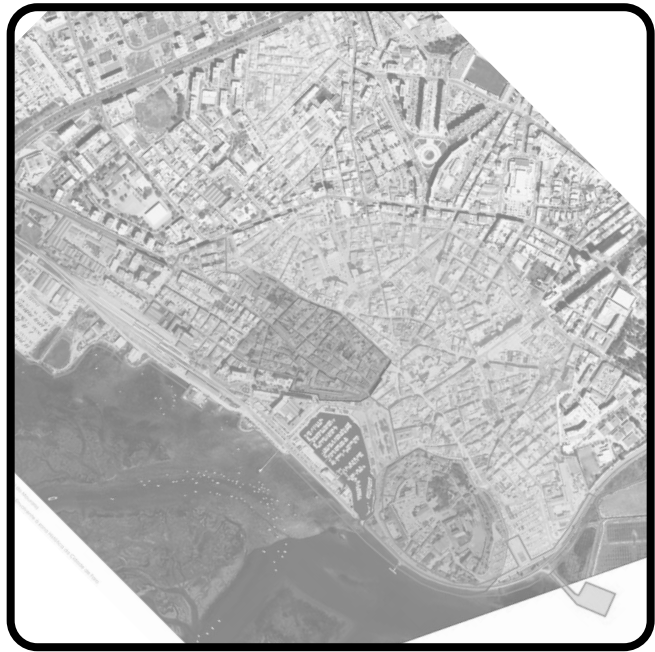

**NATIONAL FRAMEWORK**

**FARO MASTERPLAN**

**MUNICIPAL REGULATION**

**URBAN REHABILITAION PLANS (ARU)**

**POLICIES AROUND SÃO LUÍS**

Planning Framework

Masterplan 2009

Urbanization and Building

Vila Adentro

Municipal Market

Cultural Heritage Legislation

Masterplan 2021

Public Space Occupation and Advertisement

Bairro Ribenheiro

Football Stadium

Legislation for Urban Rehabilitation

Places with Historical Value ?

Mouraria

Modernist Axe

Histórica da cidade de Faro

Alto Rodes

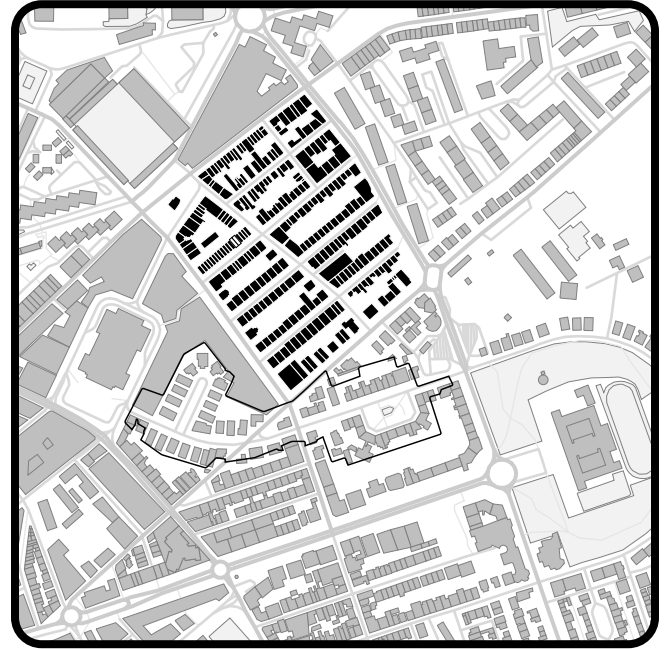

**POLICIES AROUND  
SÃO LUÍS**

Municipal Market

Football Stadium

Modernist Axe

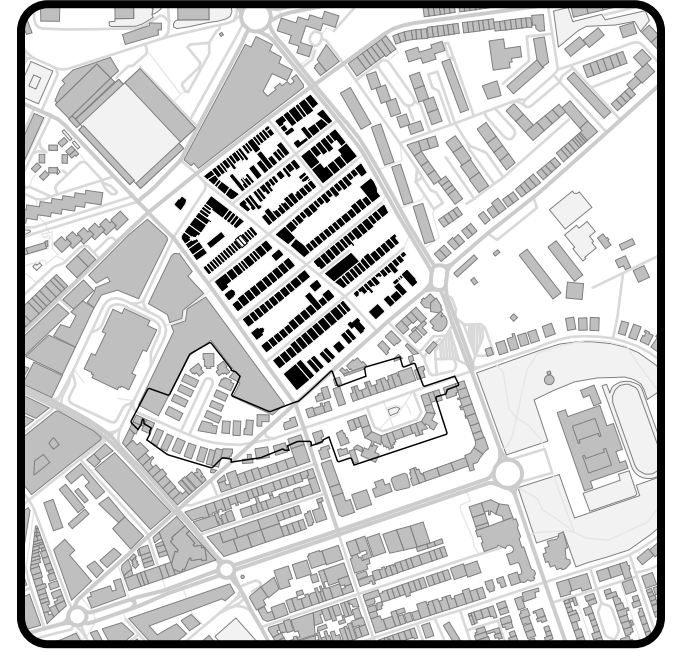

Diário da República, 2.ª série

PARTE H

N.º 141

22 de julho de 2020

Pág. 155

MUNICÍPIO DE FARO

Edital n.º 823/2020

Sumário: Aprovação da 1.ª alteração do plano de pormenor do Largo Dr. Francisco Sá Carneiro.

Aprovação da 1.ª alteração do plano de pormenor do Largo Dr. Francisco Sá Carneiro

Rogério Conceição Bacalhau Coelho, Presidente da Câmara Municipal de Faro, torna público que, na reunião de câmara de 20 de janeiro de 2020, no cumprimento do disposto no n.º 1 do artigo 90.º do do Decreto-Lei n.º 80/2015, de 14 de maio, foi deliberado submeter a proposta final da 1.ª alteração do plano de pormenor do Largo Dr. Francisco Sá Carneiro, à Assembleia Municipal.

Mais torna público que, na sessão extraordinária de 28 de janeiro de 2020, a Assembleia Municipal de Faro aprovou a 1.ª alteração do plano de pormenor do Largo Dr. Francisco Sá Carneiro.

Para efeitos do disposto na alínea d) do n.º 3 do artigo 6.º do Decreto-Lei n.º 80/2015, de 14 de maio informa ainda que, durante o período de discussão pública que antecedeu a aprovação da proposta final da alteração ao plano, decorrido entre 21 de novembro de 2019 e 18 de dezembro de 2019, não foi registada qualquer participação.

Nos termos da alínea f) do n.º 4 do artigo 191.º do supra referido decreto-lei, é publicado em anexo a este edital o excerto da deliberação da Assembleia Municipal de 28 de janeiro de 2020, bem como o Regulamento e a Planta de Implantação do plano.

POLICIES AROUND SÃO LUÍS

Municipal Market

Football Stadium

Modernist Axe

Classificação do conjunto urbano entre o Mercado Municipal e a Escola Secundária João de Deus, constituído pelas Ruas General Humberto Delgado; Praceta Coronel Pires Viegas e Praceta Eng.º Duarte Pacheco na Freguesia da Sé – Faro.

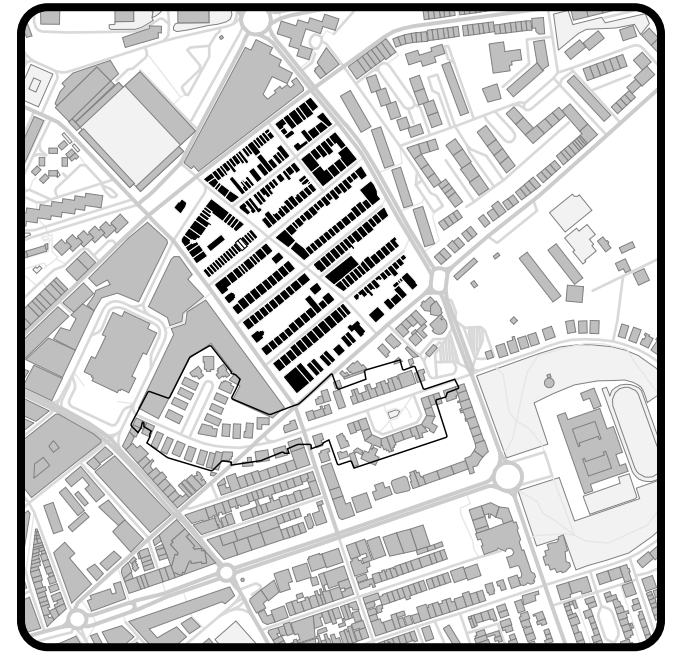
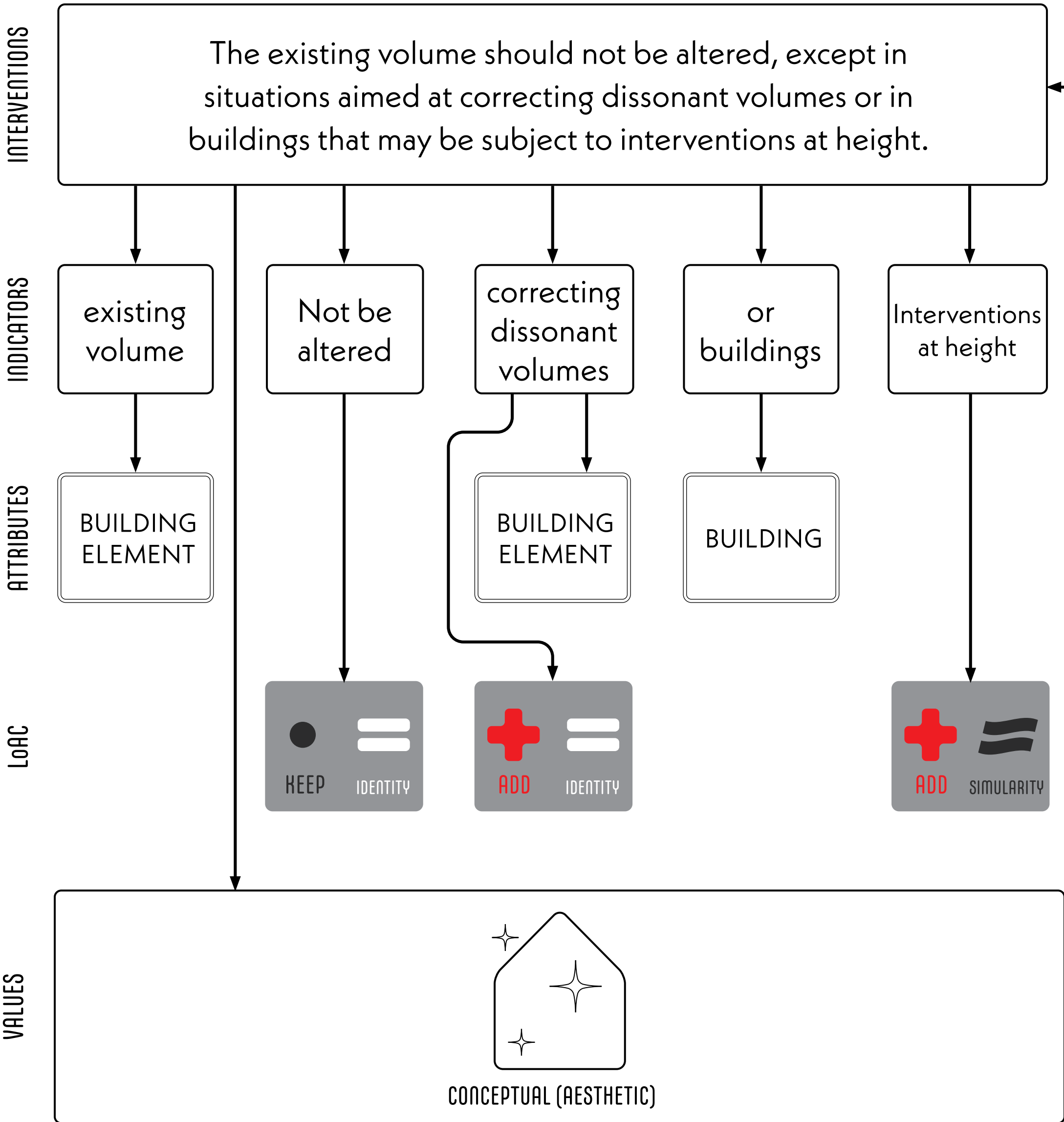

**Diário da República, 2.ª série** **PARTE H**

N.º 141 22 de julho de 2020 Pág. 155

**MUNICÍPIO DE FARO**

**Edital n.º 823/2020**

*Sumário: Aprovação da 1.ª alteração do plano de pormenor do Largo Dr. Francisco Sá Carneiro.*

**Aprovação da 1.ª alteração do plano de pormenor do Largo Dr. Francisco Sá Carneiro**

Rogério Conceição Bacalhau Coelho, Presidente da Câmara Municipal de Faro, torna público que, na reunião de câmara de 20 de janeiro de 2020, no cumprimento do disposto no n.º 1 do artigo 90.º do do Decreto-Lei n.º 80/2015, de 14 de maio, foi deliberado submeter a proposta final da 1.ª alteração do plano de pormenor do Largo Dr. Francisco Sá Carneiro, à Assembleia Municipal.

Mais torna público que, na sessão extraordinária de 28 de janeiro de 2020, a Assembleia Municipal de Faro aprovou a 1.ª alteração do plano de pormenor do Largo Dr. Francisco Sá Carneiro.

Para efeitos do disposto na alínea d) do n.º 3 do artigo 6.º do Decreto-Lei n.º 80/2015, de 14 de maio informa ainda que, durante o período de discussão pública que antecedeu a aprovação da proposta final da alteração ao plano, decorrido entre 21 de novembro de 2019 e 18 de dezembro de 2019, não foi registada qualquer participação.

Nos termos da alínea f) do n.º 4 do artigo 191.º do supra referido decreto-lei, é publicado em anexo a este edital o excerto da deliberação da Assembleia Municipal de 28 de janeiro de 2020, bem como o Regulamento e a Planta de Implantação do plano.

**POLICIES AROUND SÃO LUÍS**

Municipal Market

Football Stadium

Modernist Axe

Classificação do conjunto urbano entre o Mercado Municipal e a Escola Secundária João de Deus, constituído pelas Ruas General Humberto Delgado; Praceta Coronel Pires Viegas e Praceta Eng.º Duarte Pacheco na Freguesia da Sé – Faro.

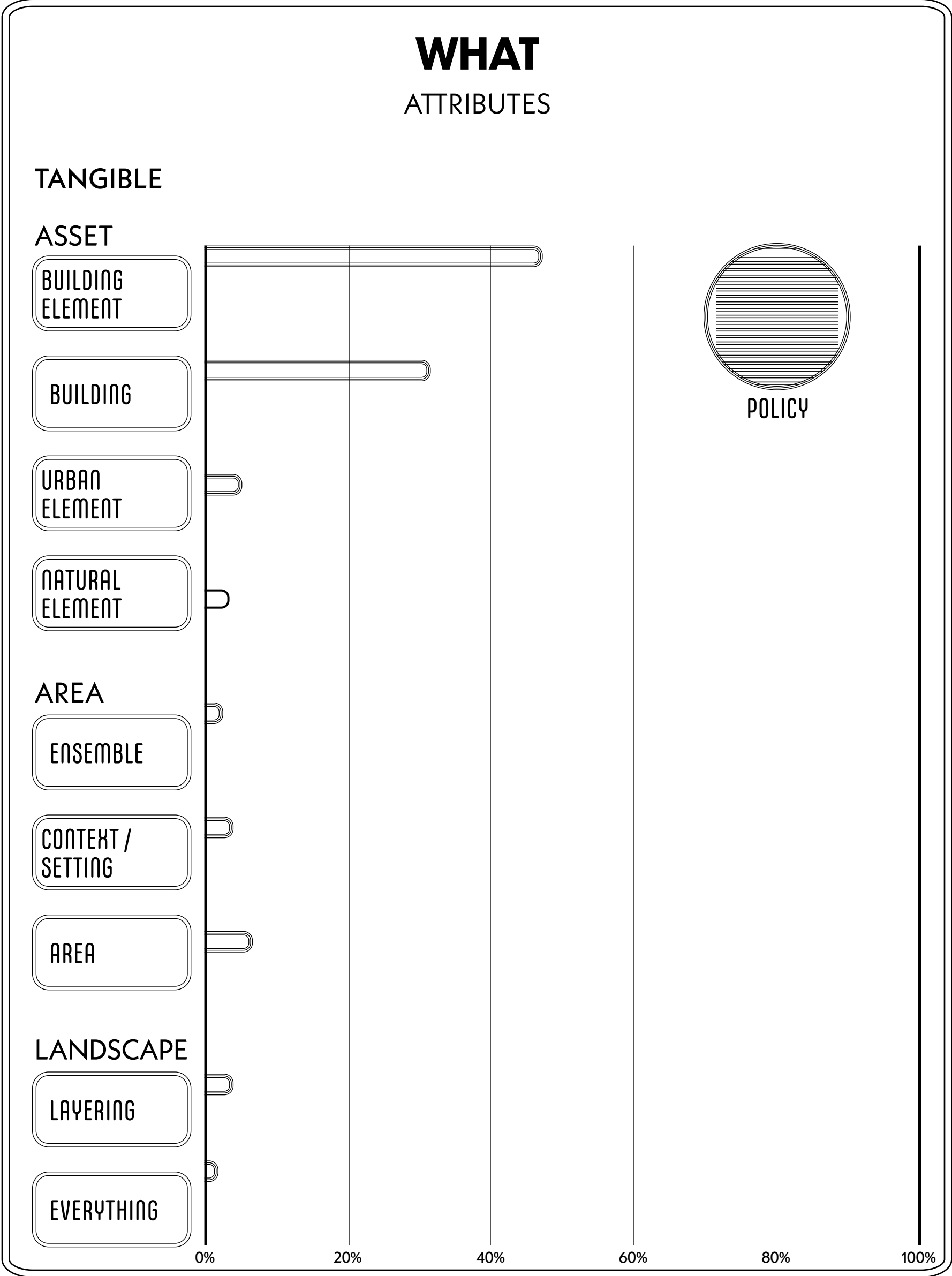



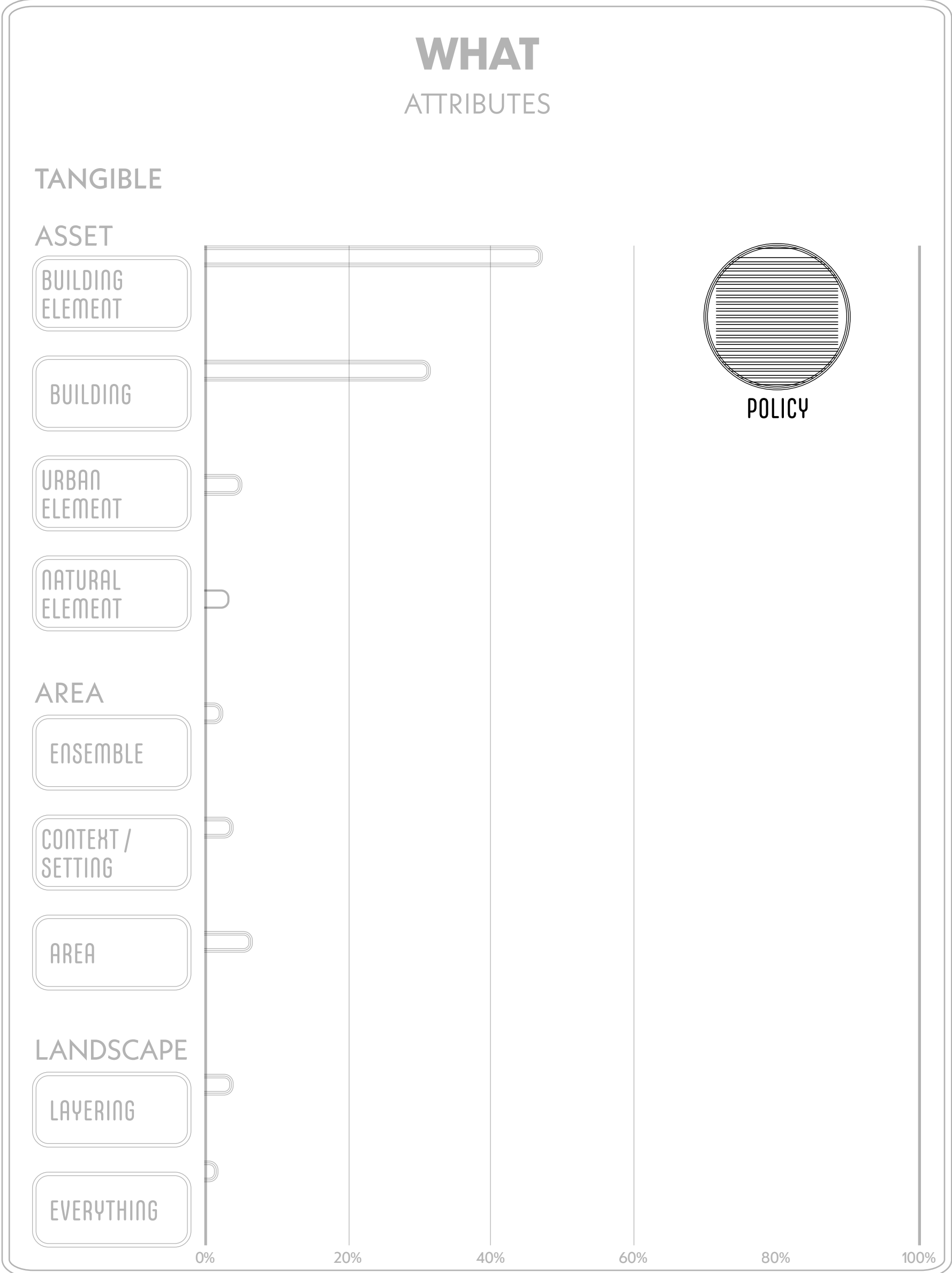
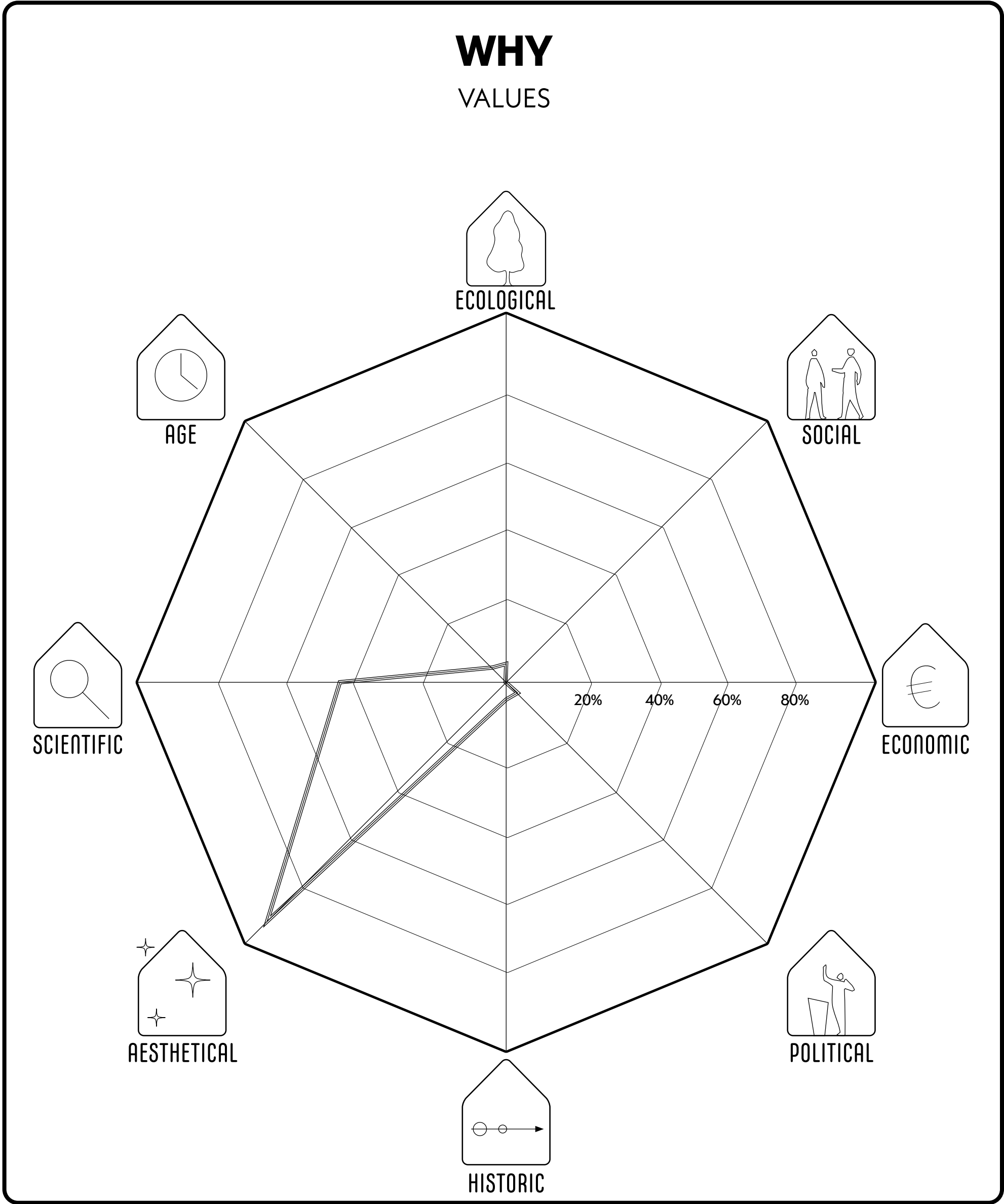



### WHICH LIMITS OF ACCEPTABLE CHANGE



ADD



KEEP



REMOVE

=  
IDENTITY

≈  
SIMILARITY

≠  
DIFFERENCE

### WHY

VALUES

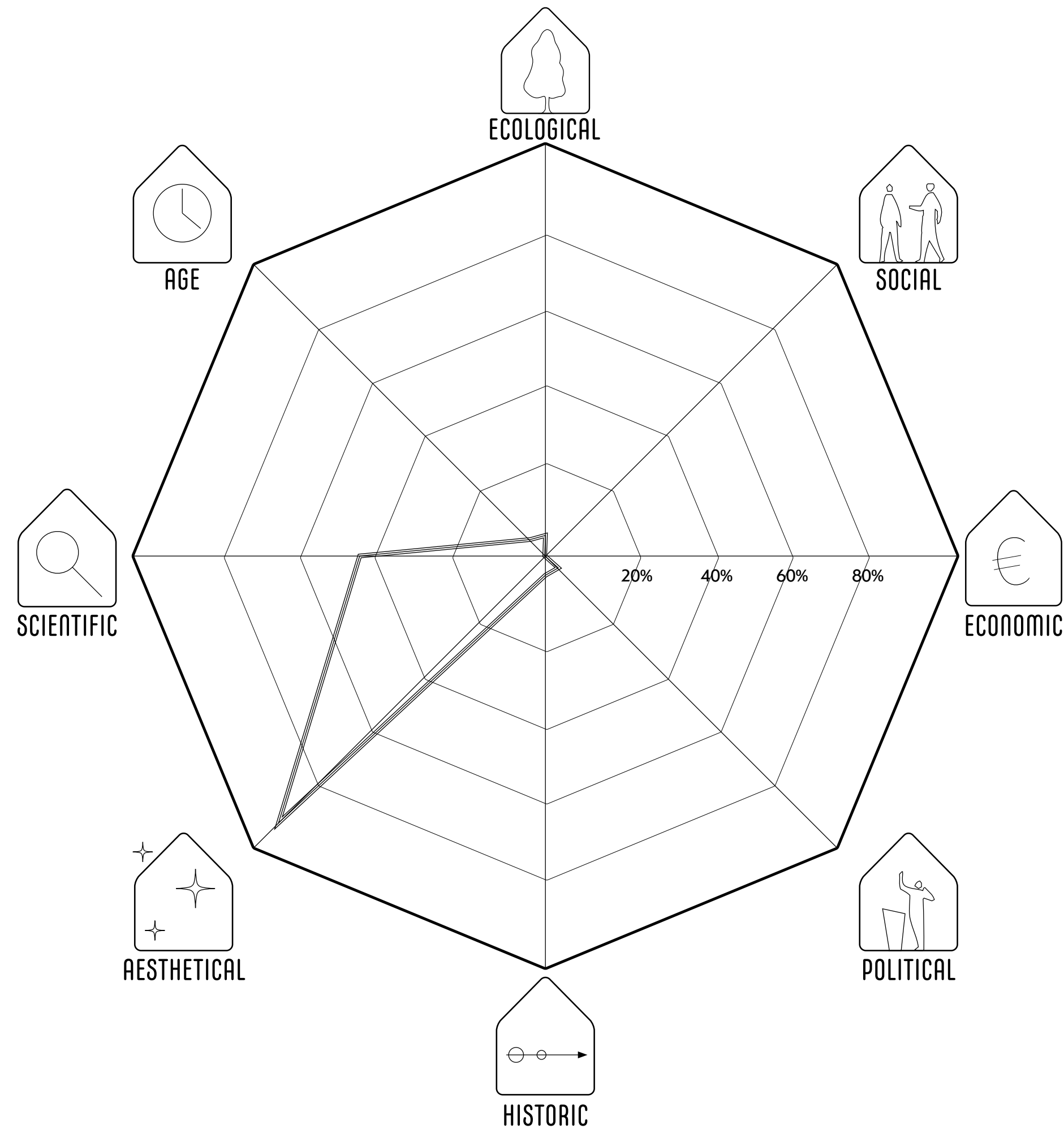

### WHAT

ATTRIBUTES

#### TANGIBLE

##### ASSET

BUILDING ELEMENT

BUILDING

URBAN ELEMENT

NATURAL ELEMENT

##### AREA

ENSEMBLE

CONTEXT / SETTING

AREA

##### LANDSCAPE

LAYERING

EVERYTHING

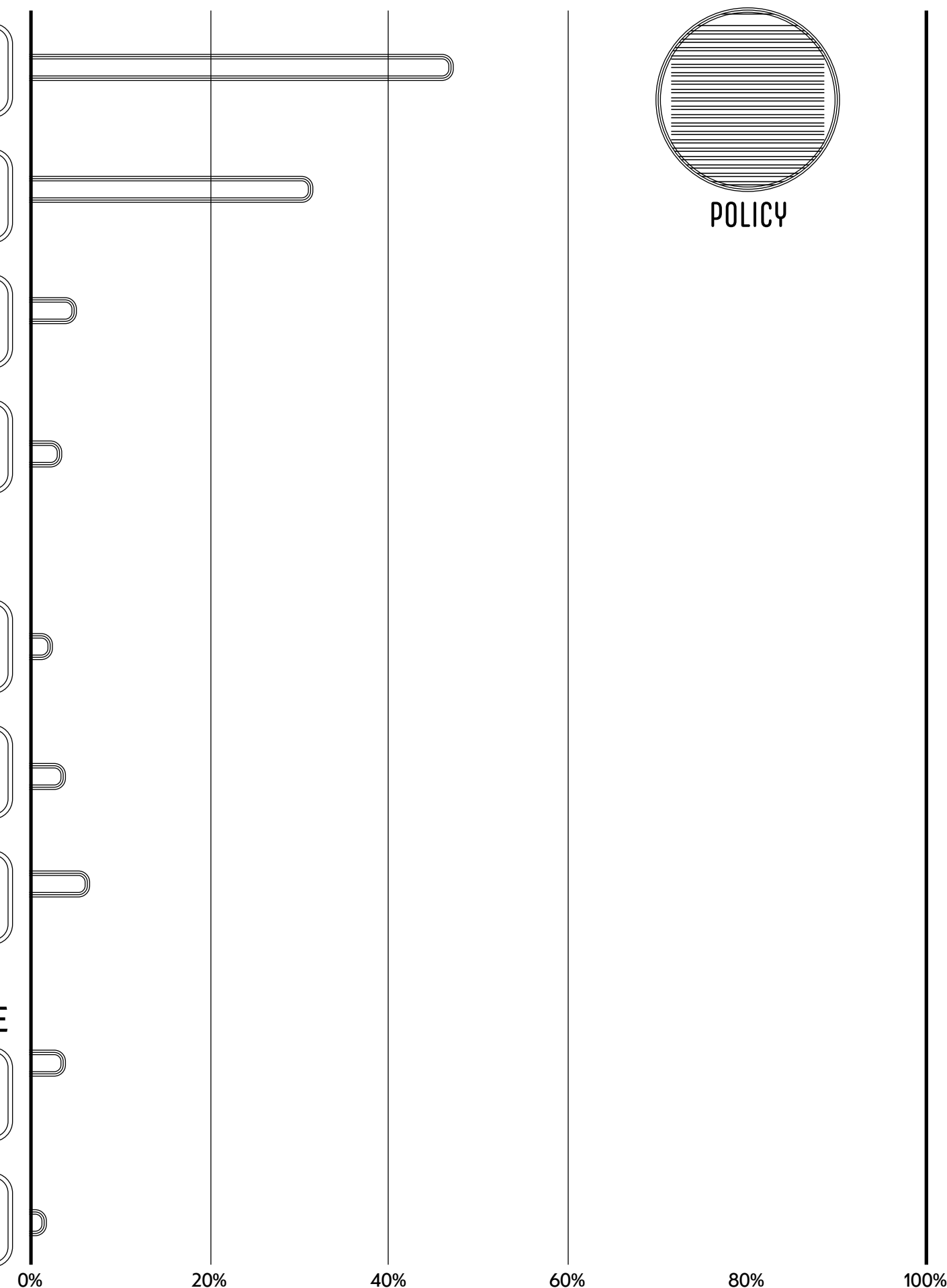

GOAL

PRODUCT

METHODS

METHODOLOGY

# PART 1 INTRODUCTION

## PART 2 RESEARCH

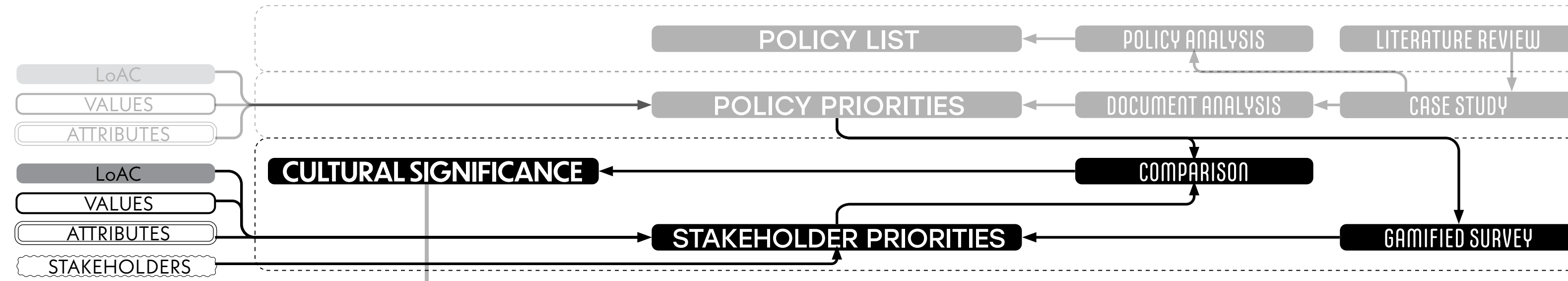

## A CONTEXT

A1 INVENTORY

A2 ANALYSIS

A3 DEFINE SIGNIFICANCE

## PART 3 DESIGN

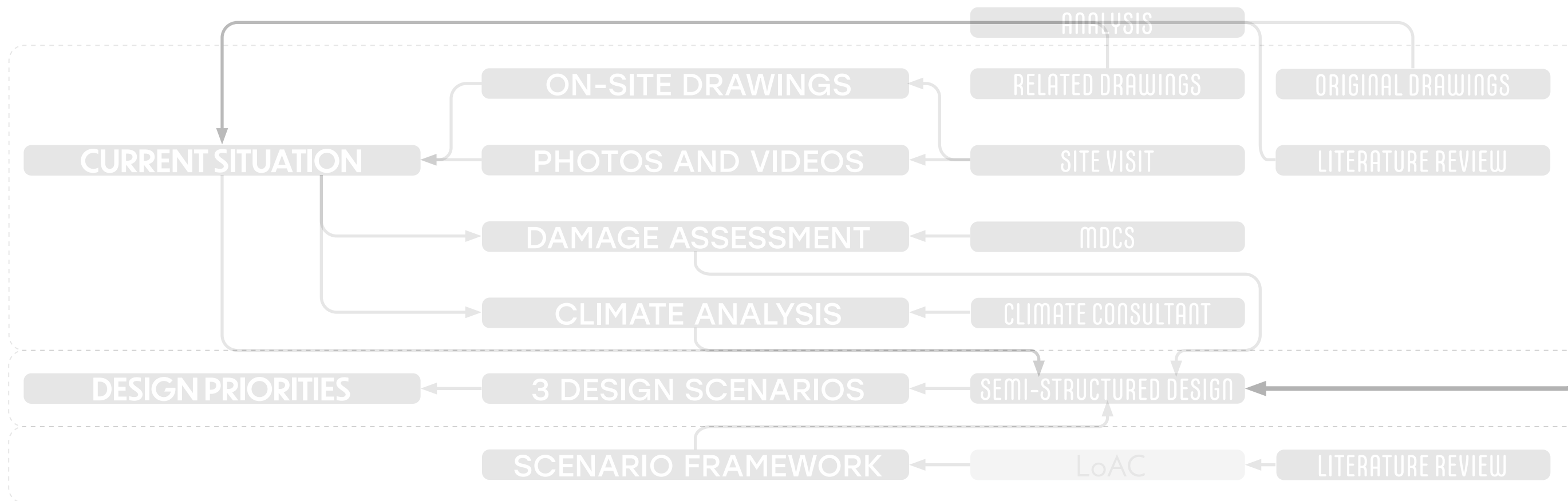

## B STRATEGY

B1 BUILDING ANALYSIS

B2 DEVELOP STRATEGY

B3 INTEGRATE

## PART 4 REFLECTION



## C MANAGE

C1 PRIORITIZE

C2 PROCESS REFLECTION



### Website, QR code

JOGUE O JOGO VOCÊ MESMO!

<https://forms.gle/UZMpiGKUSTQfB5VD7>

TU Delft Faro UAIG

Home Sobre a Investigação

### Renovar a sua casa, redesenhar o seu bairro.

**Explicação:**  
Neste jogo, o participante é convidado a escolher entre quatro opções que considera ser as mais adequadas. Desta forma demonstrará o que mais valoriza nas políticas de gestão urbanística em vigor. Este inquérito tem a duração média de 15 minutos e o participante tem a oportunidade de conhecer melhor as políticas, regulamentos e estratégias urbanas e de gestão do património cultural da zona de São Luís em Faro.

*O objectivo do jogo é revelar a perspectiva das pessoas sobre o património cultural e os regulamentos que regulam esse património. Os resultados serão utilizados exclusivamente para esta investigação e poderão ser publicados.*

Início do jogo

### Municipality Market



### Pictures in Action





### WHICH LIMITS OF ACCEPTABLE CHANGE



ADD



KEEP



REMOVE

IDENTITY

SIMILARITY

DIFFERENCE

### WHY

VALUES

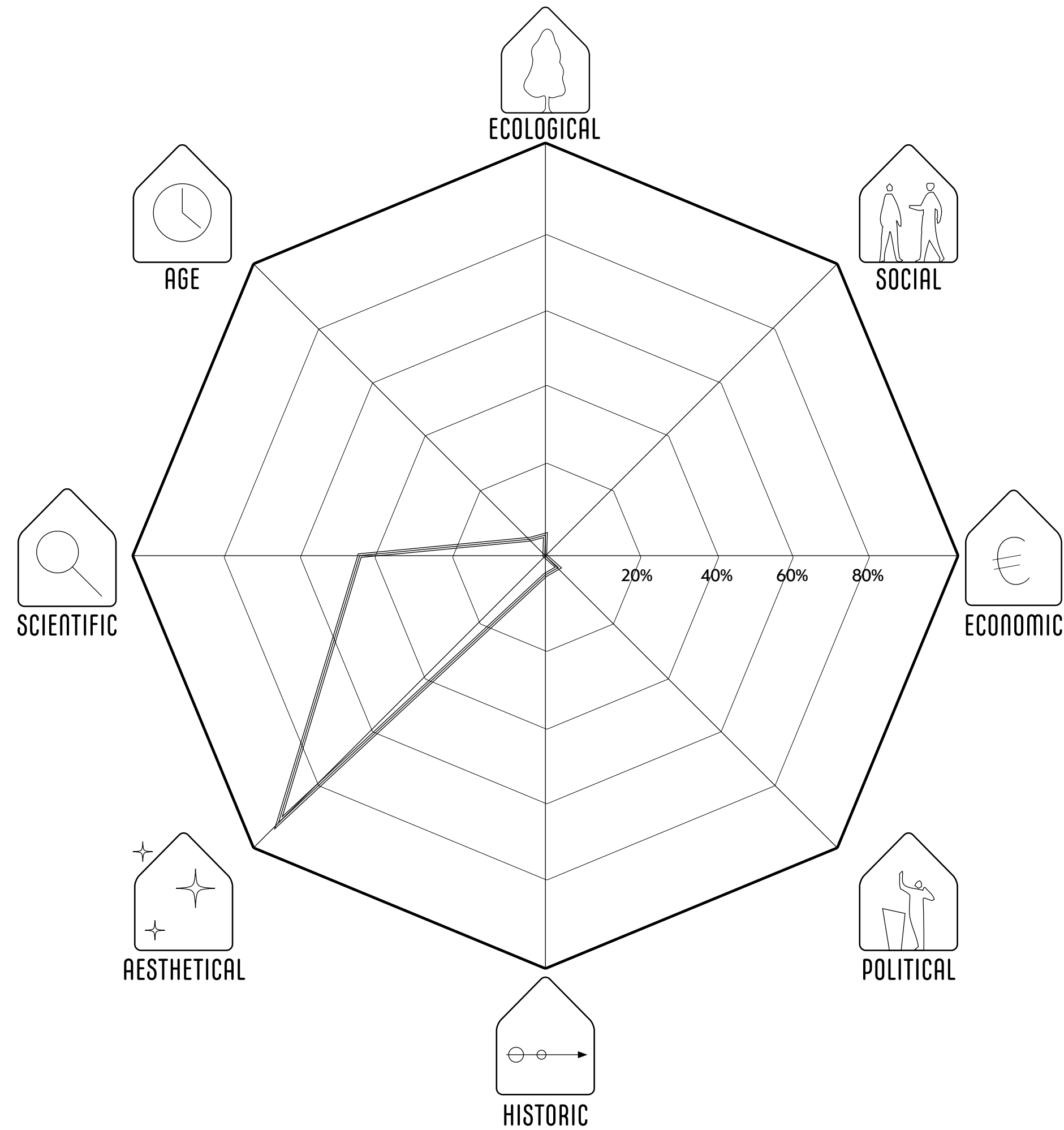

### WHAT

ATTRIBUTES

#### TANGIBLE

##### ASSET

BUILDING ELEMENT

BUILDING

URBAN ELEMENT

NATURAL ELEMENT

##### AREA

ENSEMBLE

CONTEXT / SETTING

AREA

##### LANDSCAPE

LAYERING

EVERYTHING

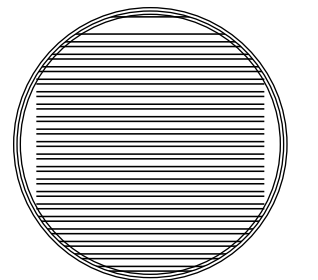

POLICY

0% 20% 40% 60% 80% 100%



### WHICH LIMITS OF ACCEPTABLE CHANGE



ADD



KEEP



REMOVE

=  
IDENTITY

≈  
SIMILARITY

≠  
DIFFERENCE

### WHY

VALUES

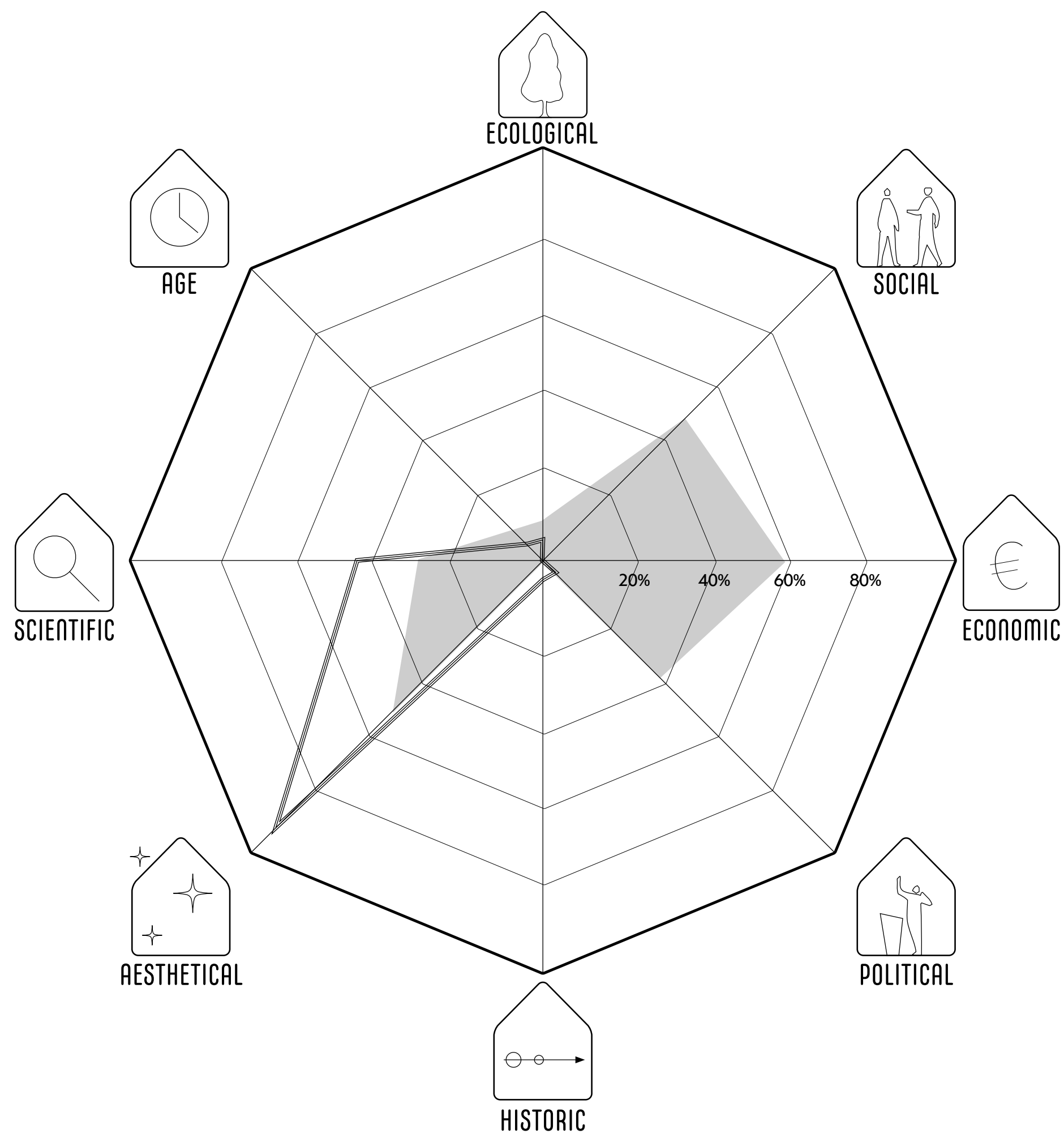

### WHAT

ATTRIBUTES

#### TANGIBLE

##### ASSET

BUILDING  
ELEMENT

BUILDING

URBAN  
ELEMENT

NATURAL  
ELEMENT

##### AREA

ENSEMBLE

CONTEXT /  
SETTING

AREA

##### LANDSCAPE

LAYERING

EVERYTHING

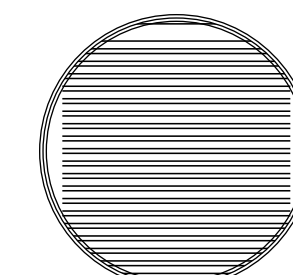

POLICY



QUESTIONS

0% 20% 40% 60% 80% 100%



### WHICH LIMITS OF ACCEPTABLE CHANGE



ADD



KEEP



REMOVE

=  
IDENTITY

≈  
SIMILARITY

≠  
DIFFERENCE

### WHY VALUES

VALUES

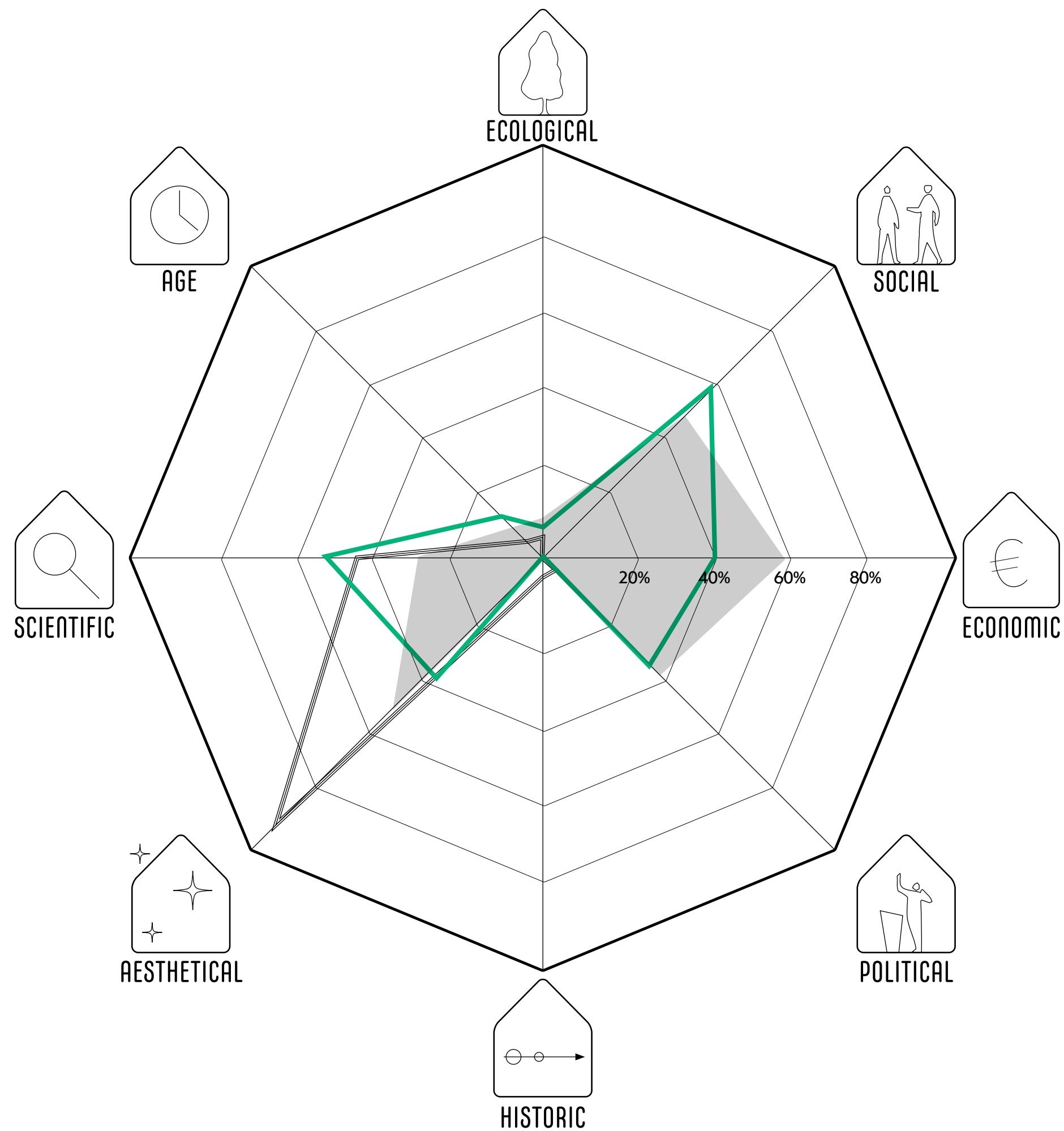

### WHAT ATTRIBUTES

ATTRIBUTES

#### TANGIBLE

##### ASSET

BUILDING  
ELEMENT

BUILDING

URBAN  
ELEMENT

NATURAL  
ELEMENT

##### AREA

ENSEMBLE

CONTEXT /  
SETTING

AREA

##### LANDSCAPE

LAYERING

EVERYTHING

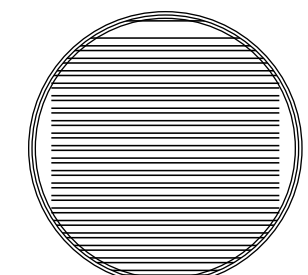
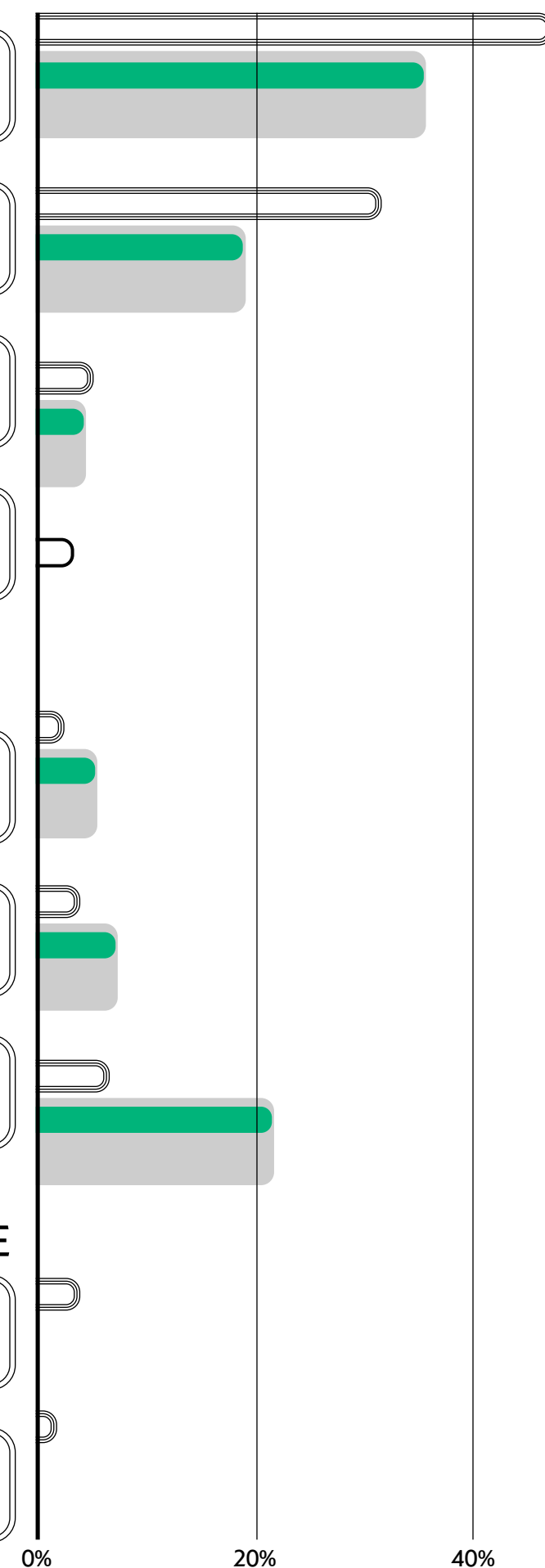

POLICY



QUESTIONS



COMMUNITY

0% 20% 40% 60% 80% 100%



### WHICH LIMITS OF ACCEPTABLE CHANGE



ADD



KEEP



REMOVE

=  
IDENTITY

≈  
SIMILARITY

≠  
DIFFERENCE

### WHY VALUES

VALUES

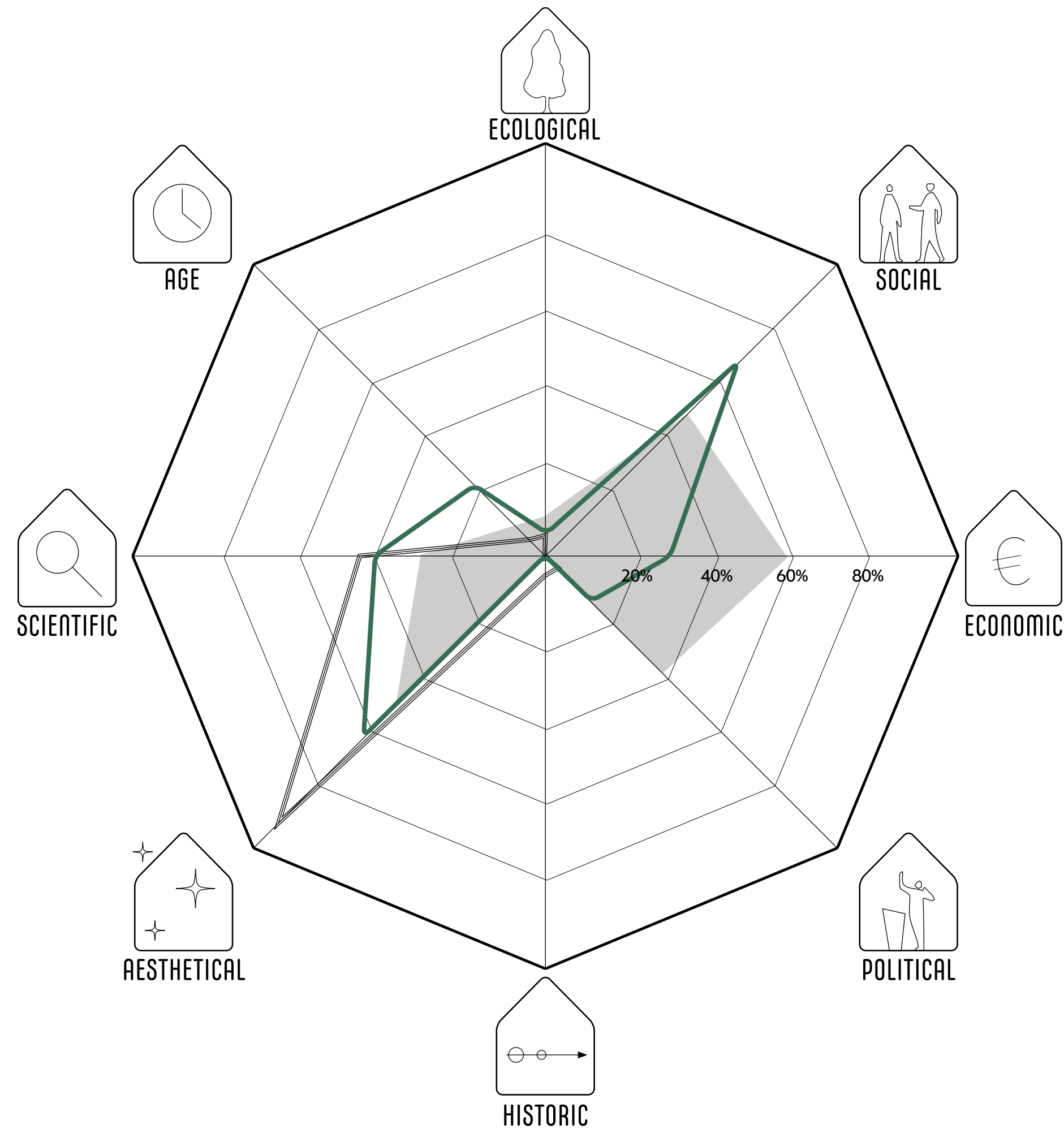

### WHAT ATTRIBUTES

ATTRIBUTES

#### TANGIBLE

##### ASSET

BUILDING  
ELEMENT

BUILDING

URBAN  
ELEMENT

NATURAL  
ELEMENT

##### AREA

ENSEMBLE

CONTEXT /  
SETTING

AREA

##### LANDSCAPE

LAYERING

EVERYTHING

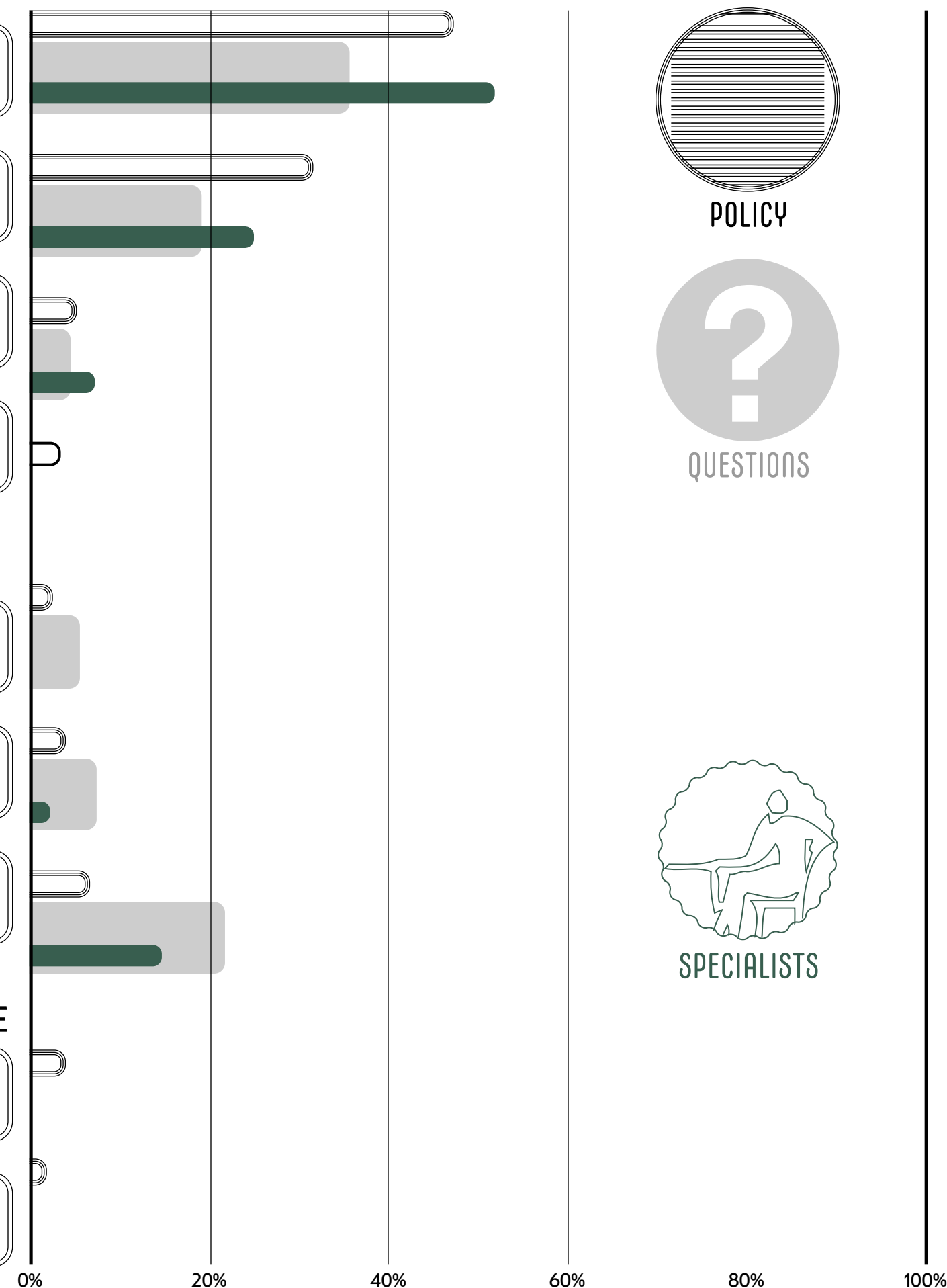

POLICY



QUESTIONS



SPECIALISTS





### WHICH LIMITS OF ACCEPTABLE CHANGE



ADD



KEEP



REMOVE

=  
IDENTITY

≈  
SIMILARITY

≠  
DIFFERENCE

### WHY

#### VALUES

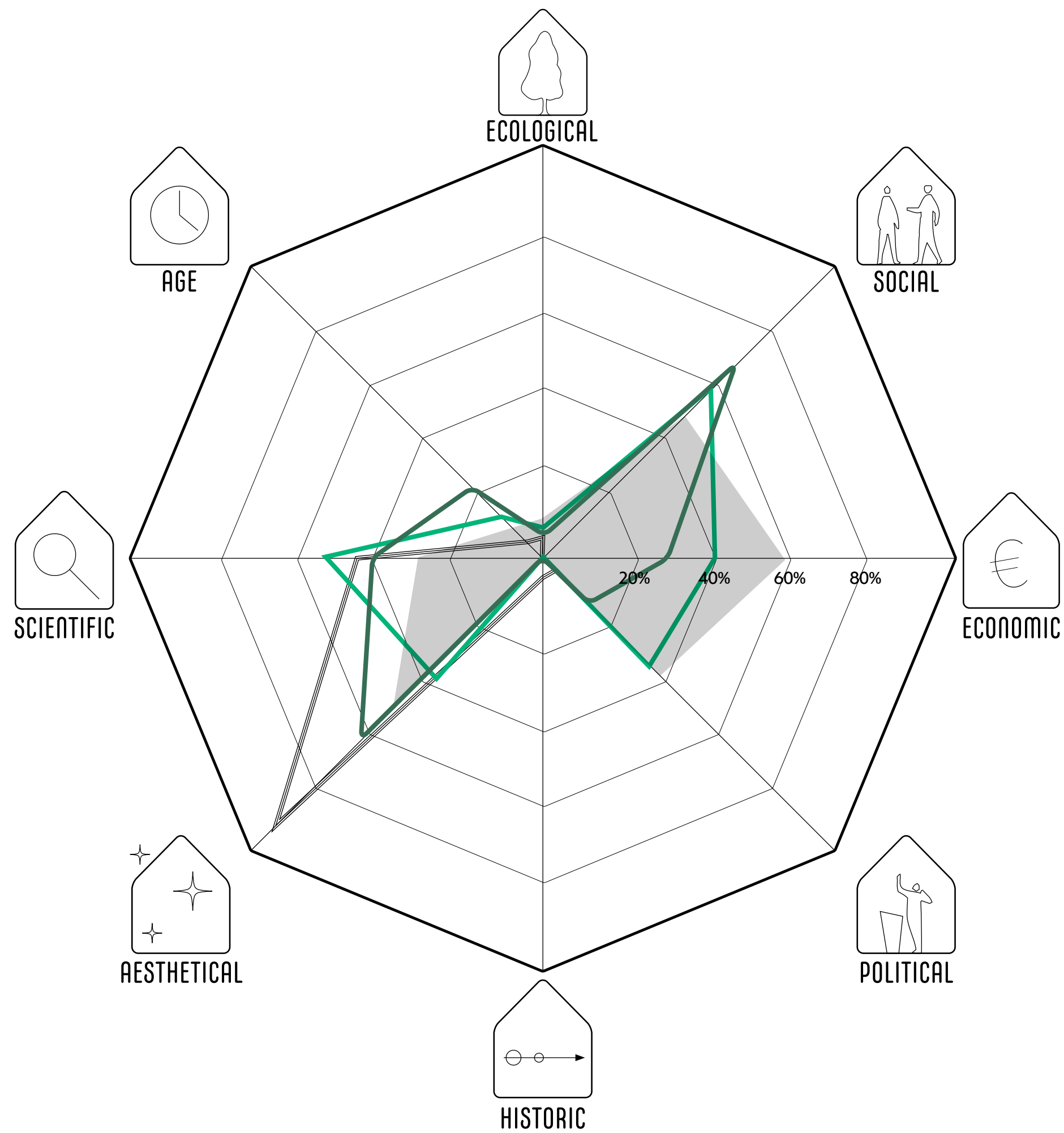

### WHAT

#### ATTRIBUTES

#### TANGIBLE

##### ASSET

BUILDING  
ELEMENT

BUILDING

URBAN  
ELEMENT

NATURAL  
ELEMENT

##### AREA

ENSEMBLE

CONTEXT /  
SETTING

AREA

##### LANDSCAPE

LAYERING

EVERYTHING

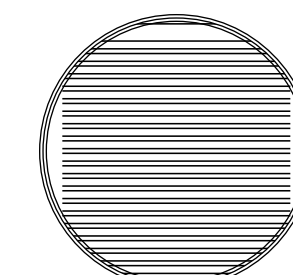
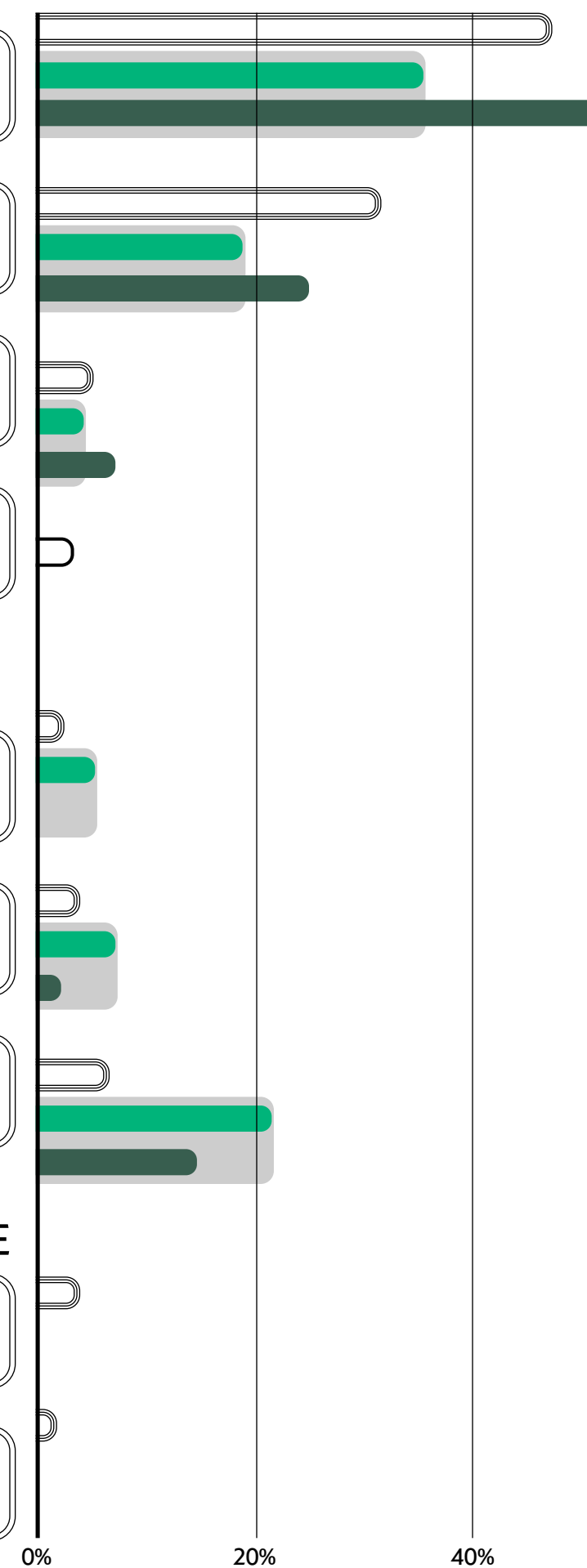

POLICY



QUESTIONS



COMMUNITY



SPECIALISTS

0% 20% 40% 60% 80% 100%



### WHICH LIMITS OF ACCEPTABLE CHANGE



ADD



KEEP



REMOVE

IDENTITY

SIMILARITY

DIFFERENCE

### WHY

#### VALUES

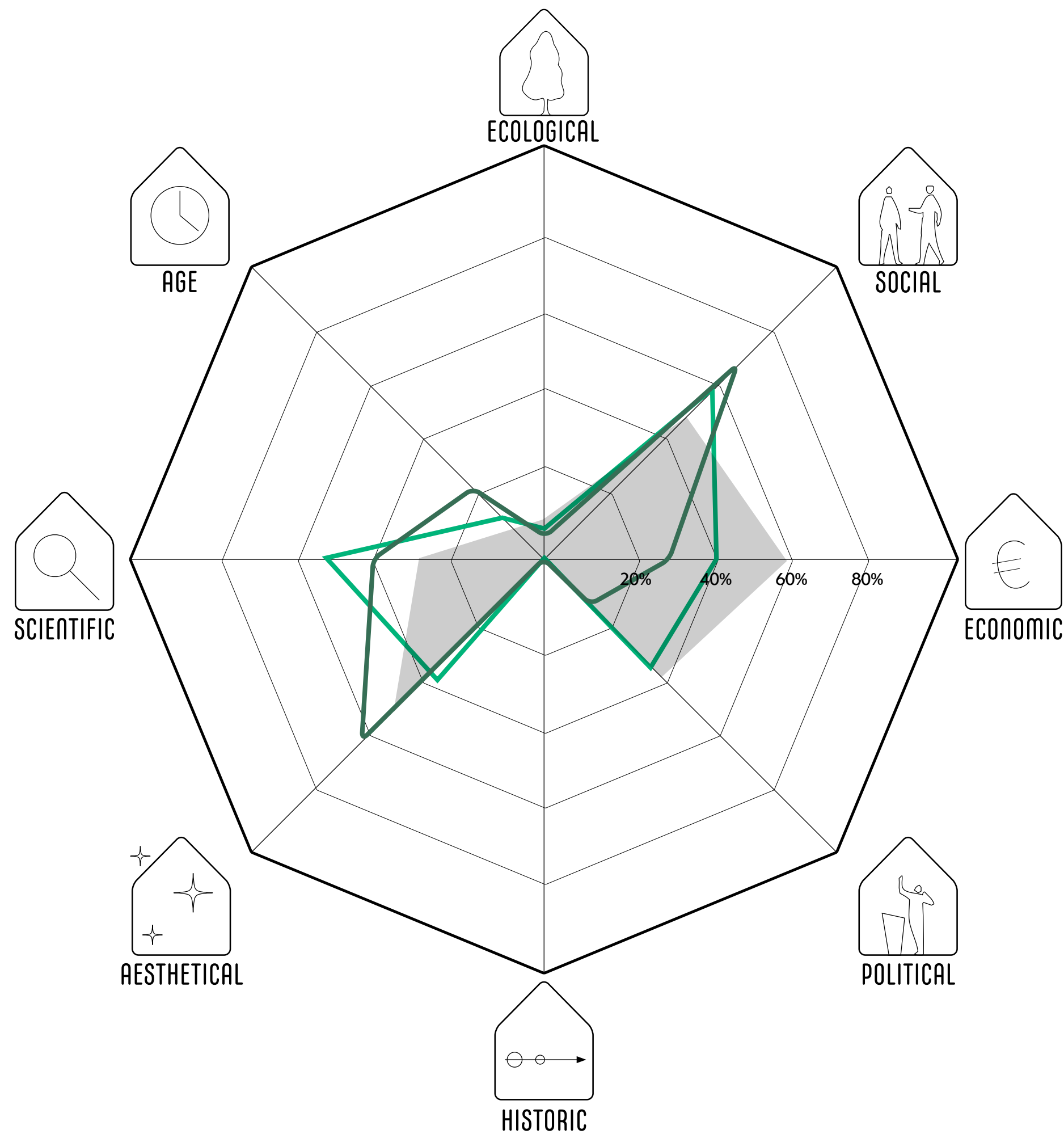

### WHAT

#### ATTRIBUTES

#### TANGIBLE

##### ASSET

BUILDING ELEMENT

BUILDING

URBAN ELEMENT

NATURAL ELEMENT

##### AREA

ENSEMBLE

CONTEXT / SETTING

AREA

##### LANDSCAPE

LAYERING

EVERYTHING

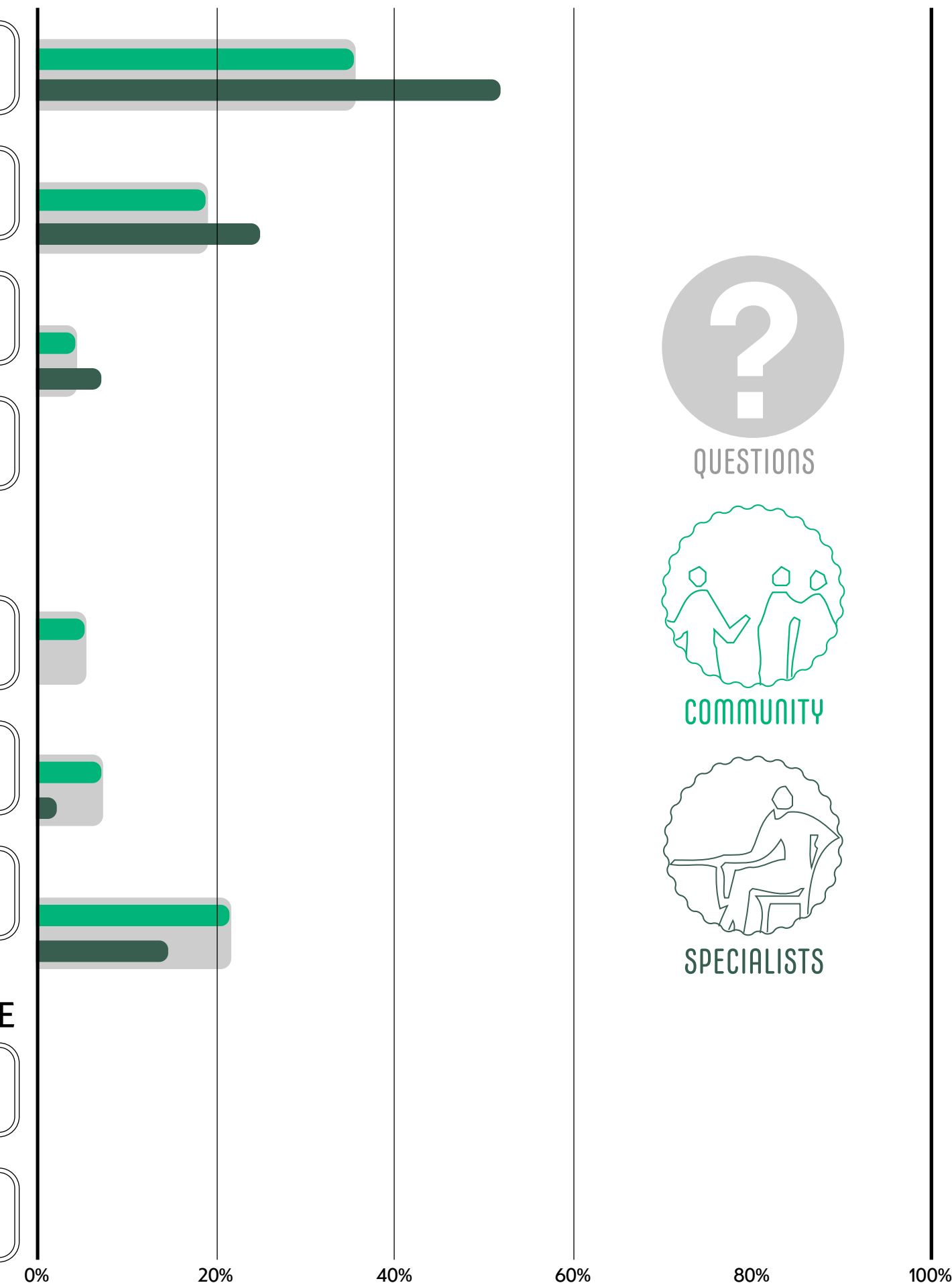

QUESTIONS



COMMUNITY



SPECIALISTS

**PART 1 INTRODUCTION**

**PART 2 RESEARCH**

**PART 3 DESIGN**

**PART 4 REFLECTION**

GOAL

PRODUCT

METHODS

METHODOLOGY

# PART 1 INTRODUCTION

# PART 2 RESEARCH

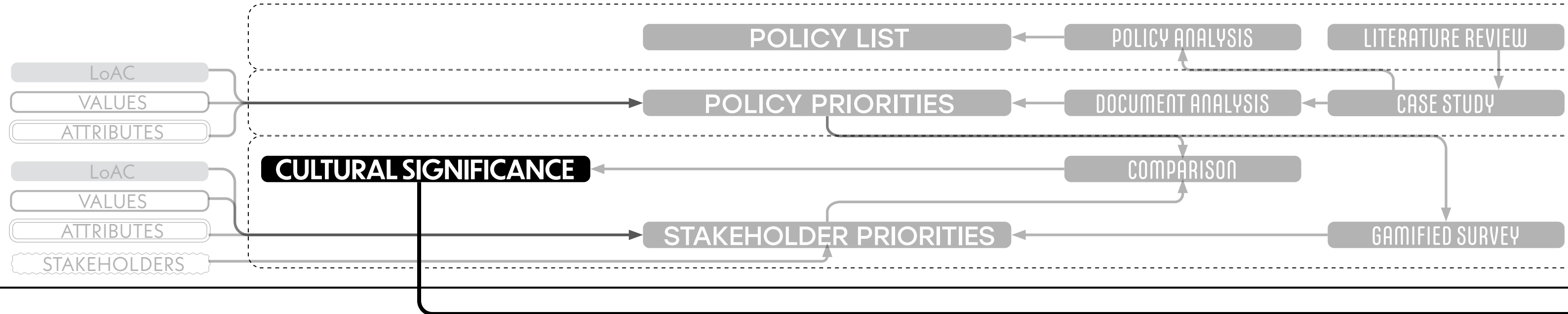

# A CONTEXT

- A1 INVENTORY
- A2 ANALYSIS
- A3 DEFINE SIGNIFICANCE

# PART 3 DESIGN

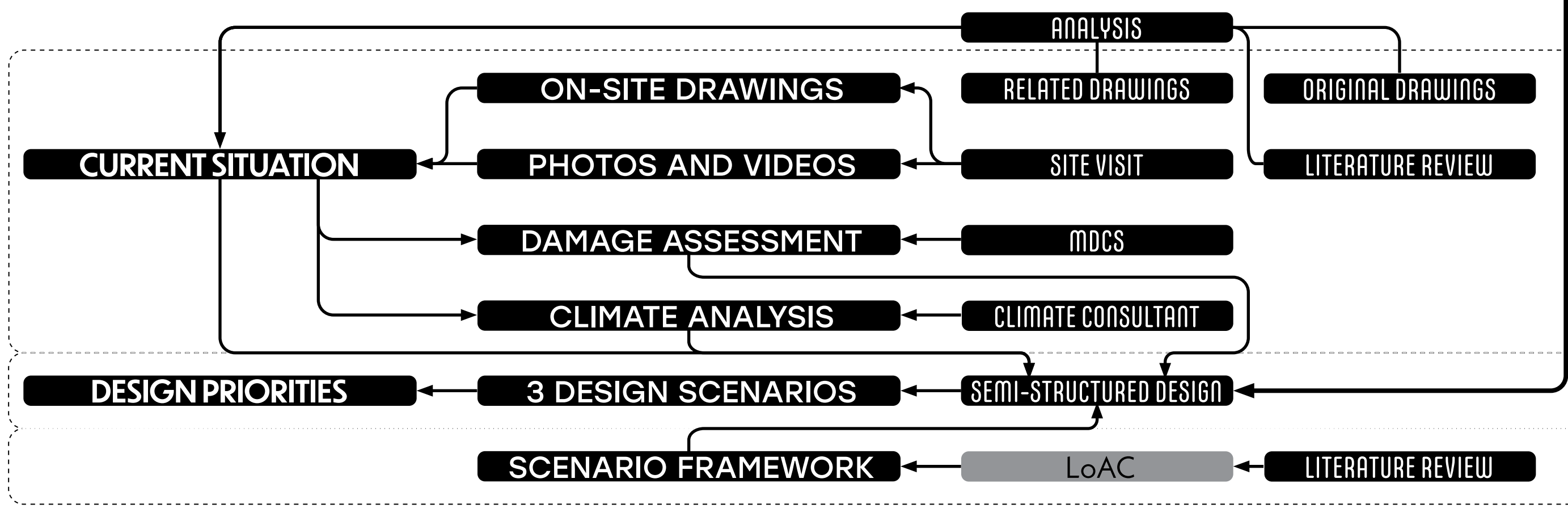

# B STRATEGY

- B1 BUILDING ANALYSIS
- B2 DEVELOP STRATEGY
- B3 INTEGRATE

# PART 4 REFLECTION



# C MANAGE

- C1 PRIORITIZE
- C2 PROCESS REFLECTION

GOAL

PRODUCT

METHODS

METHODOLOGY

# PART 1 INTRODUCTION

# PART 2 RESEARCH

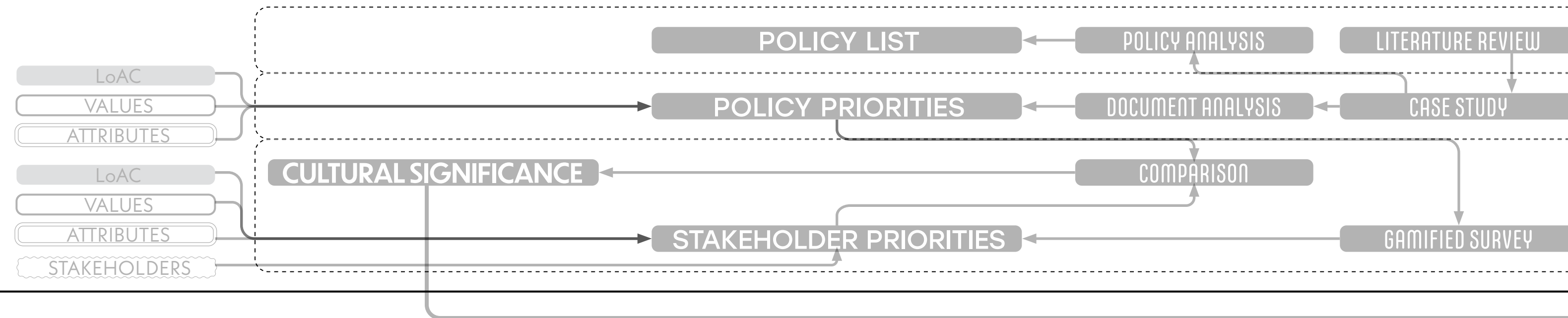

# A CONTEXT

- A1 INVENTORY
- A2 ANALYSIS
- A3 DEFINE SIGNIFICANCE

# PART 3 DESIGN

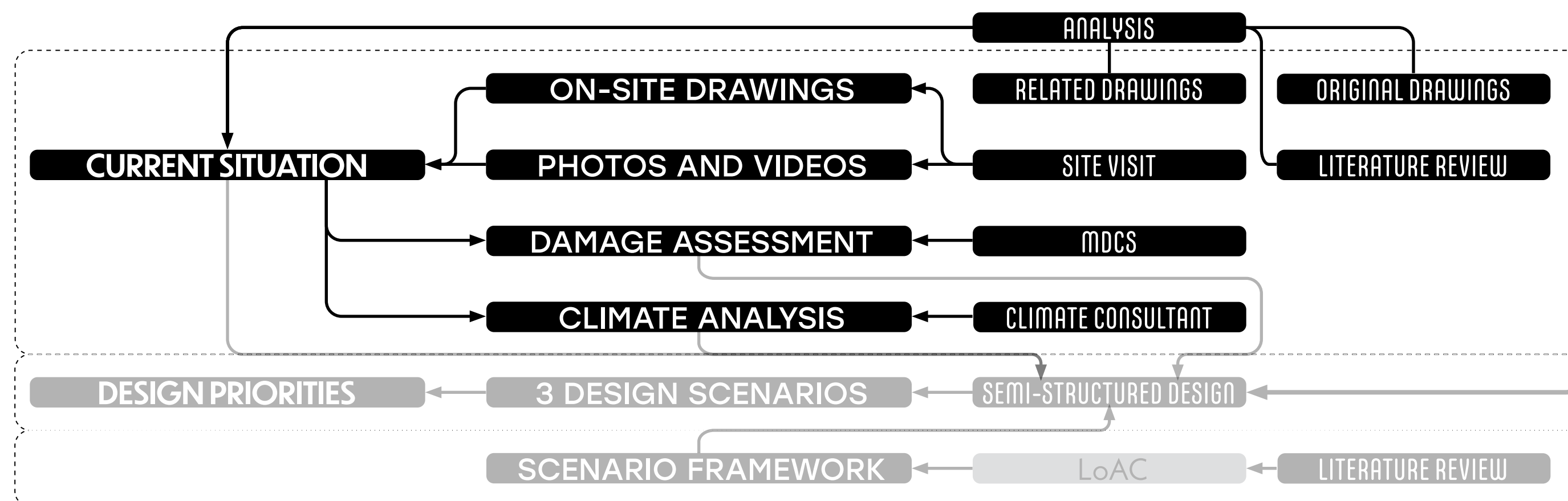

# B STRATEGY

- B1 BUILDING ANALYSIS
- B2 DEVELOP STRATEGY
- B3 INTEGRATE

# PART 4 REFLECTION

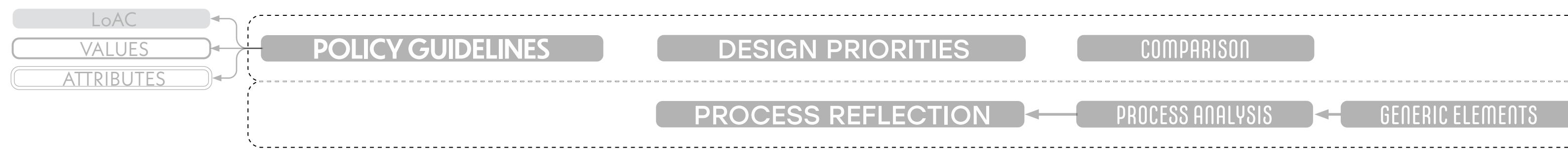

# C MANAGE

- C1 PRIORITIZE
- C2 PROCESS REFLECTION



São Luís



Block

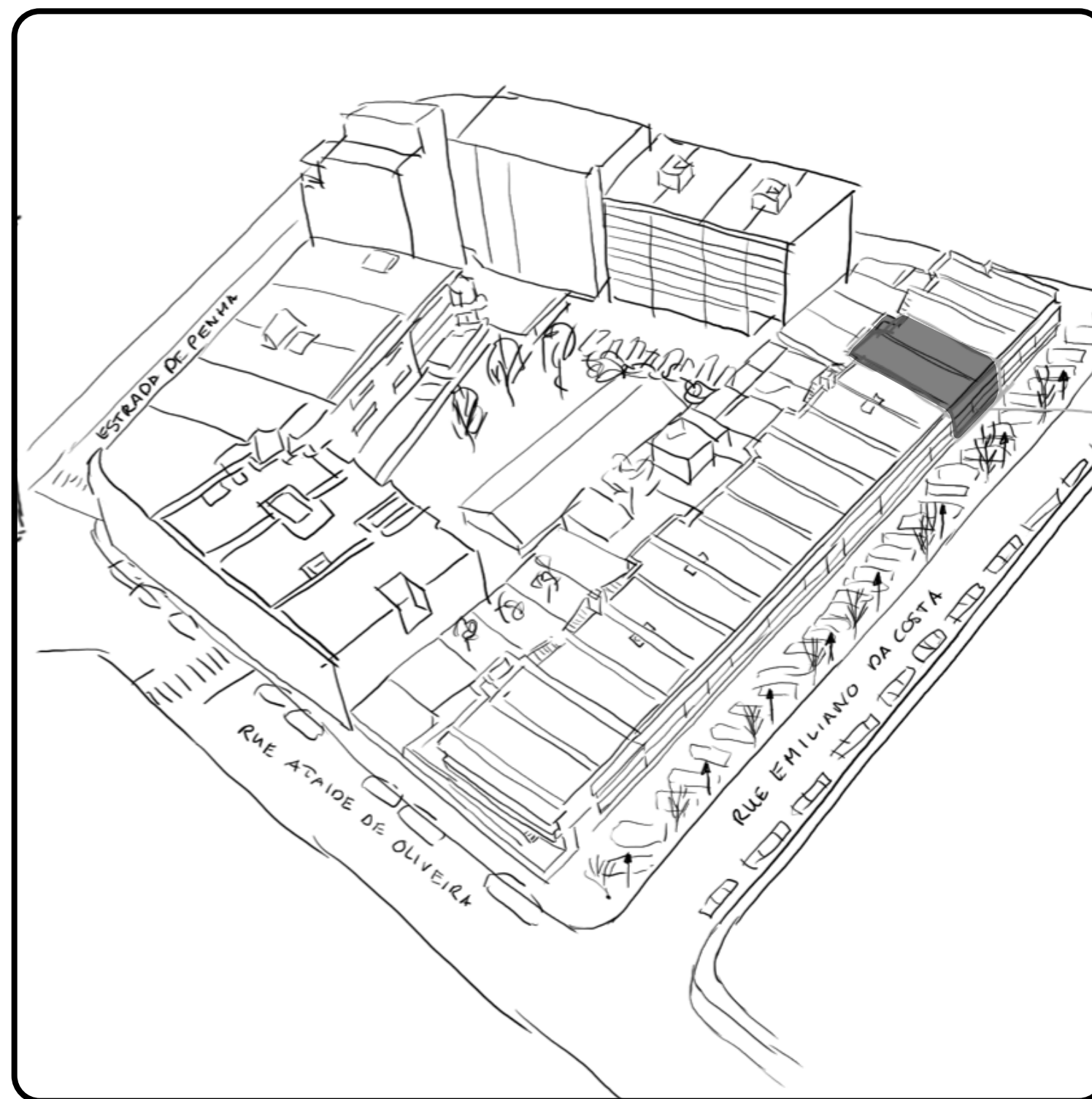

Photo



### SITE VISIT

PICTURES OF HOUSE, STREET NEIGHBORHOOD



### ON-SITE DRAWINGS

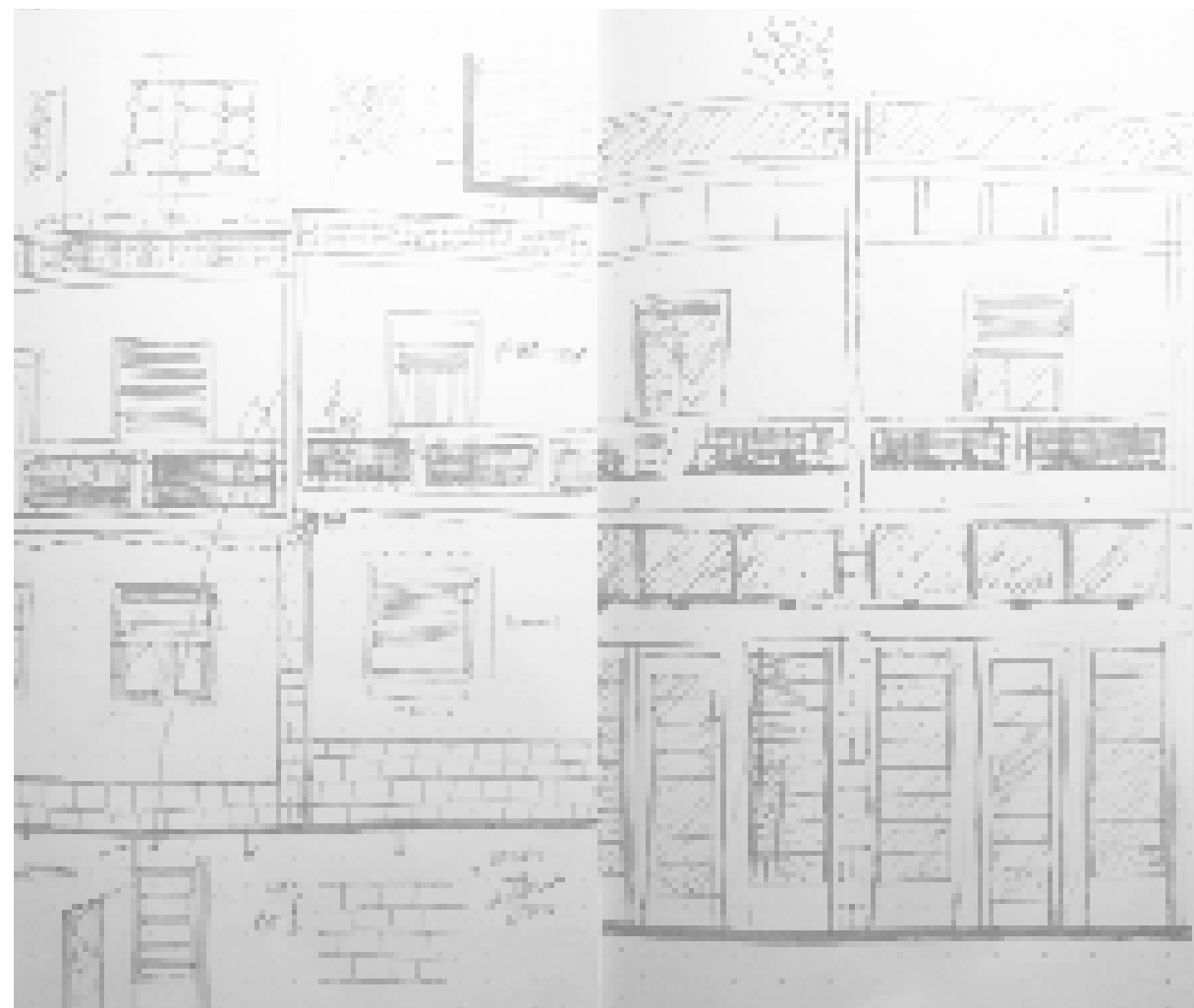

### ORIGINAL DRAWINGS

DRAWINGS BY JORGE DE OLIVIERA OF HOUSE

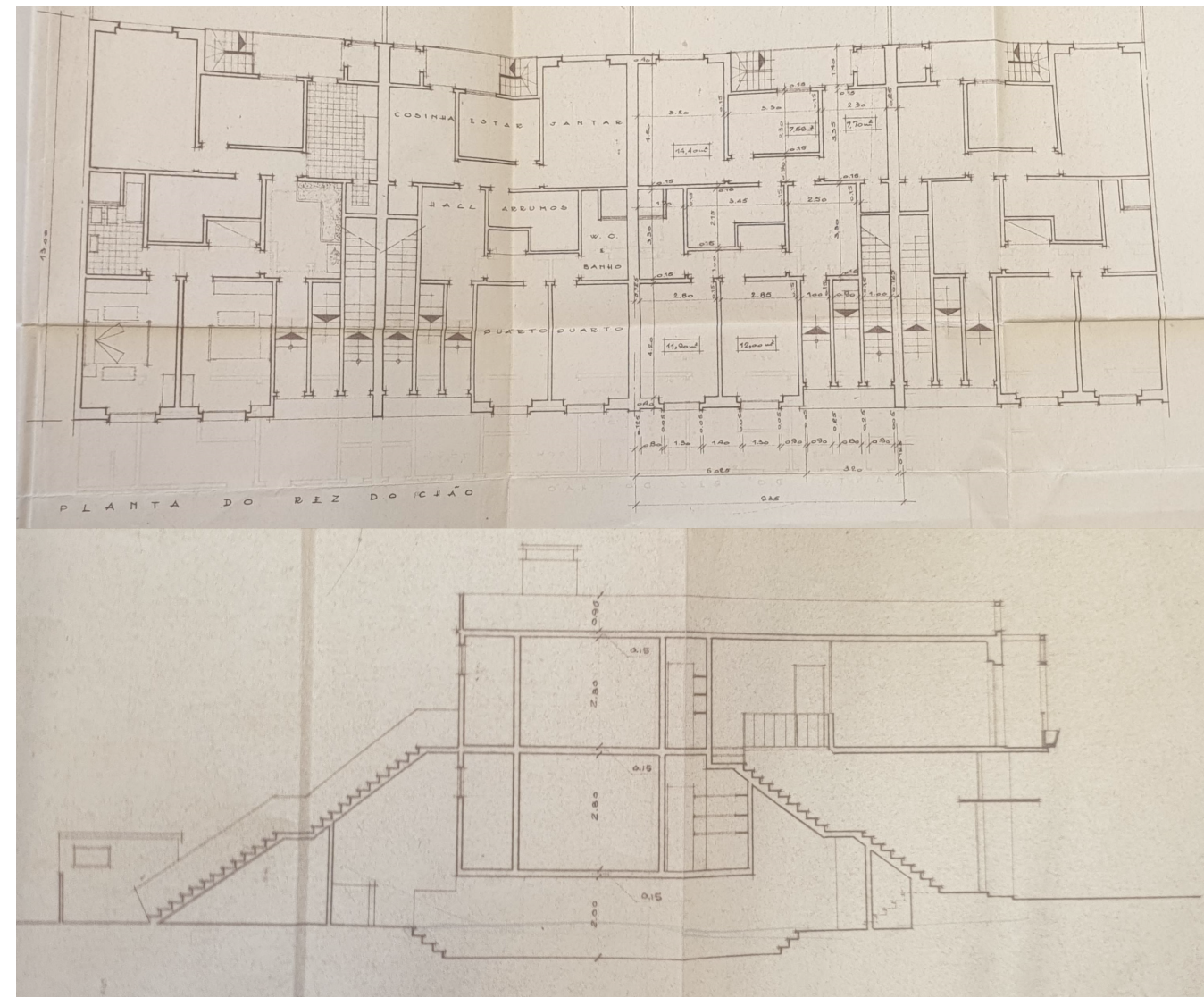

DRAWINGS BY JORGE DE OLIVIERA AND GOMEZ DA COSTA OF HOUSES IN NEIGHBORHOOD



### SOURCES

#### 1925-1965 ALGARVE ARCHITECTURE



Agarez Ricardo Costa. 2016. Algarve Building : Modernism Regionalism and Architecture in the South of Portugal 1925-1965. New York: Routledge Taylor & Francis Group.

#### THESIS ON GOMES DA COSTA

Victor Hugo de Jesus Faustino, "Manuel Gomes da Costa e a arquitectura moderna em Faro" (Master Thesis Universidade de Évora, 2018), <http://hdl.handle.net/10174/29780>.

#### WALL CONSTRUCTION METHODS

Luís Silva et al., SEISMIC PERFORMANCE OF PORTUGUESE MASONRY INFILL WALLS: FROM TRADITIONAL SYSTEMS TO NEW SOLUTIONS (2019).

#### DICTORIAL REGIME AND ARCHITECTURE

Licordari, Mariangela. "The Difficult Affirmation of Modern Architecture in the Portugal of the Salazarist Regime." Review of Arts and Humanities 6, no. 2 (2017): 10. <https://doi.org/10.15640/rah.v6n2a2>.







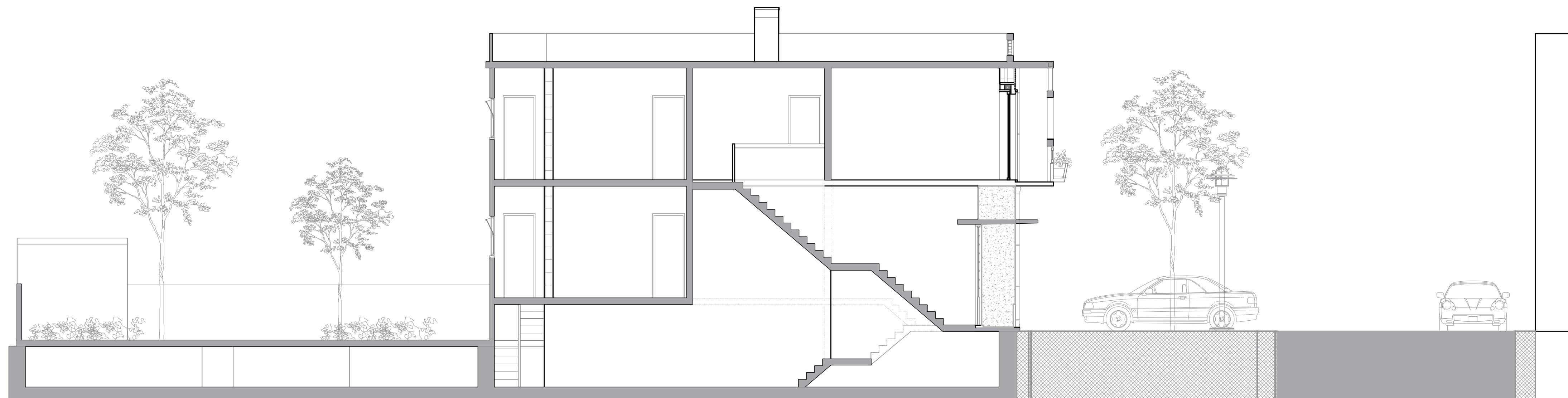

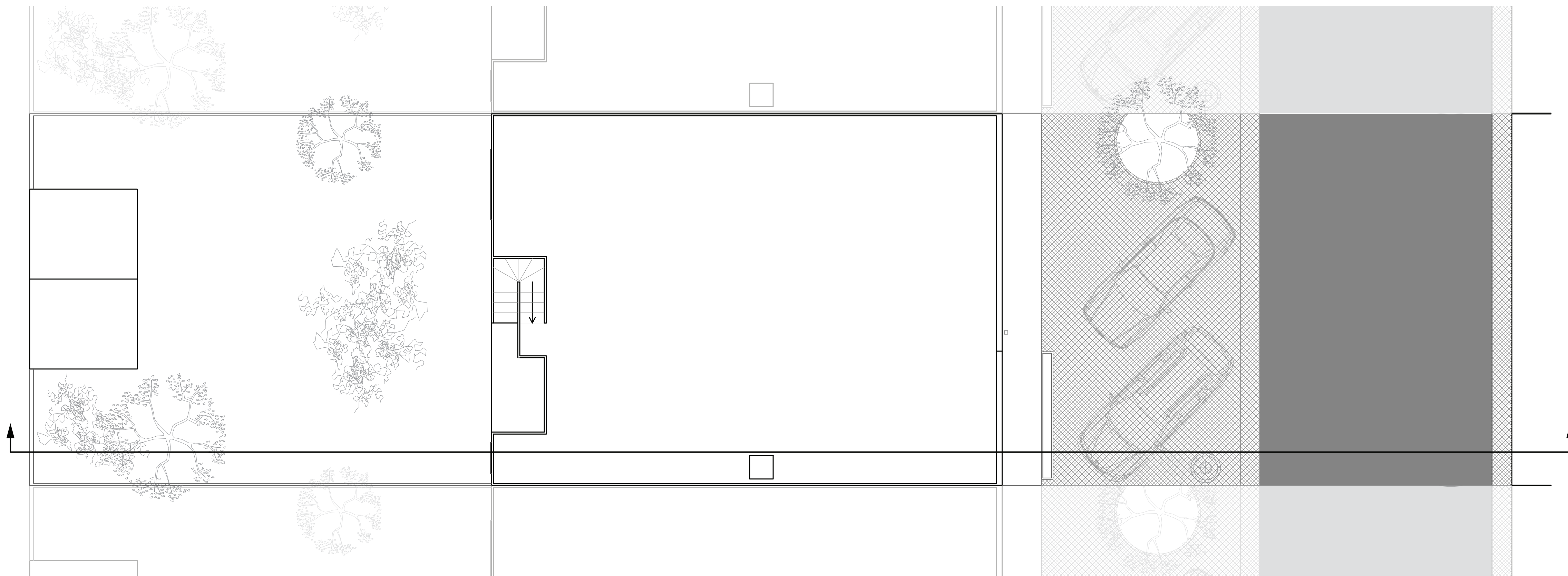

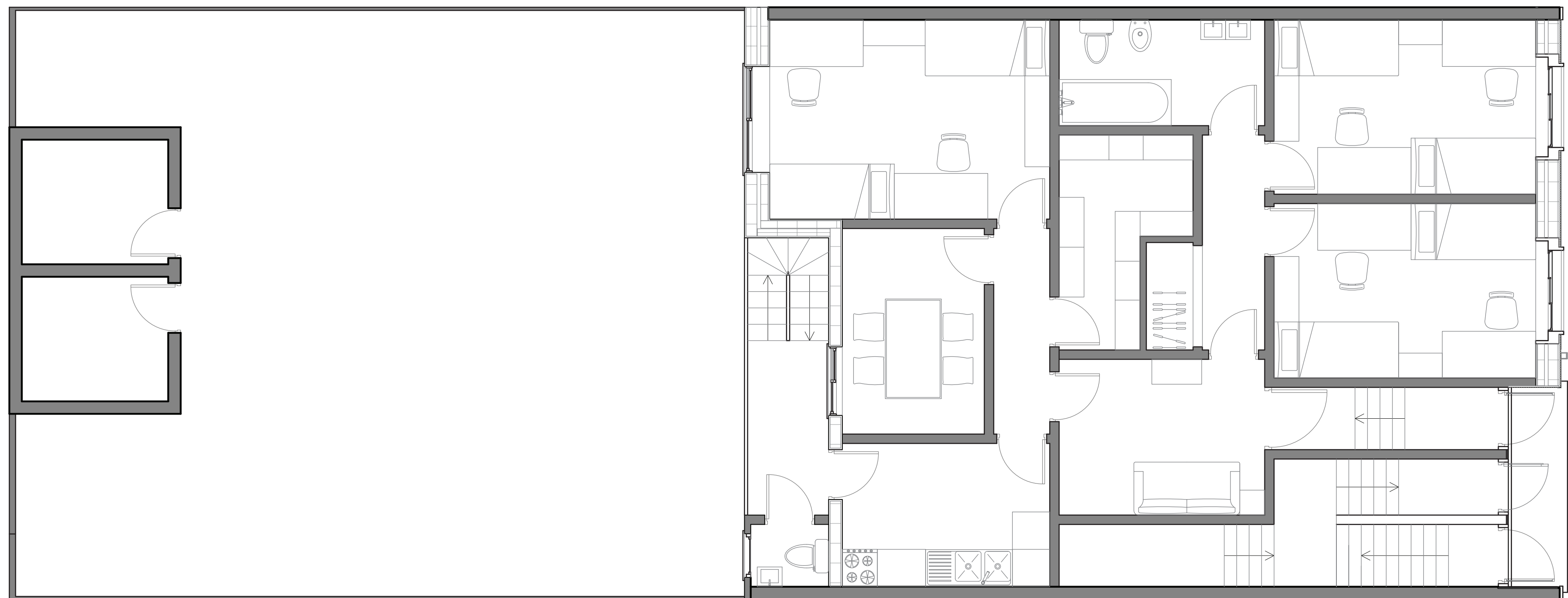

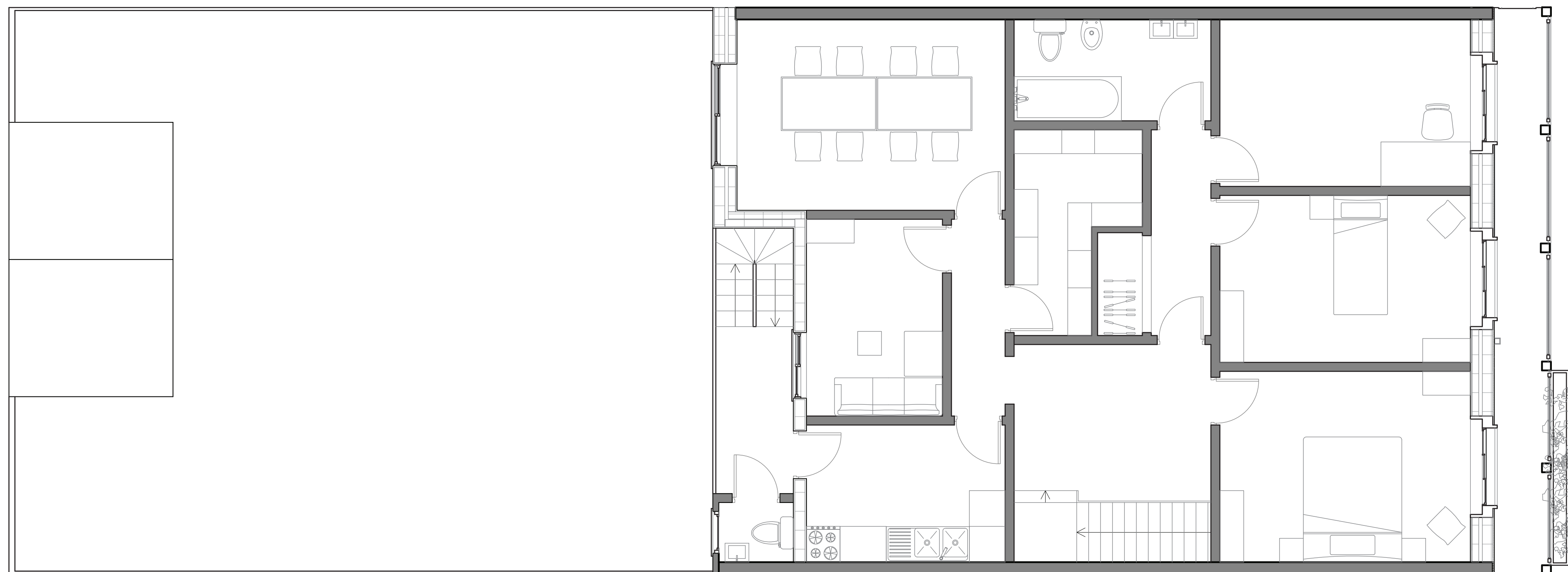



GOAL

PRODUCT

METHODS

# PART 1 INTRODUCTION

# PART 2 RESEARCH

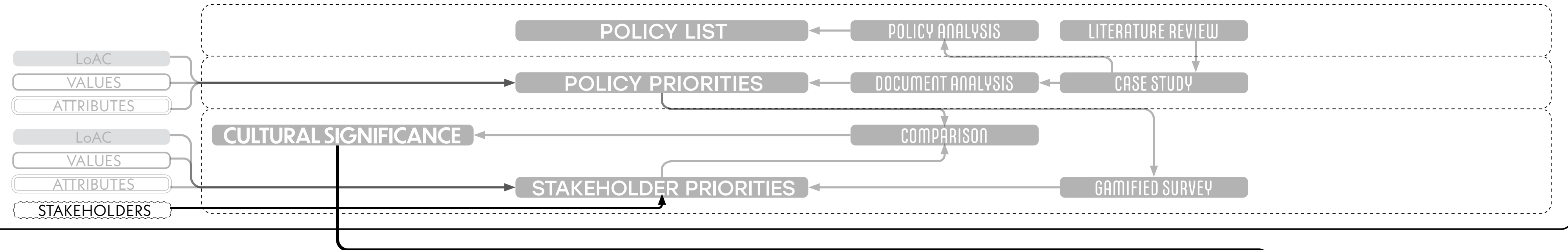

# PART 3 DESIGN

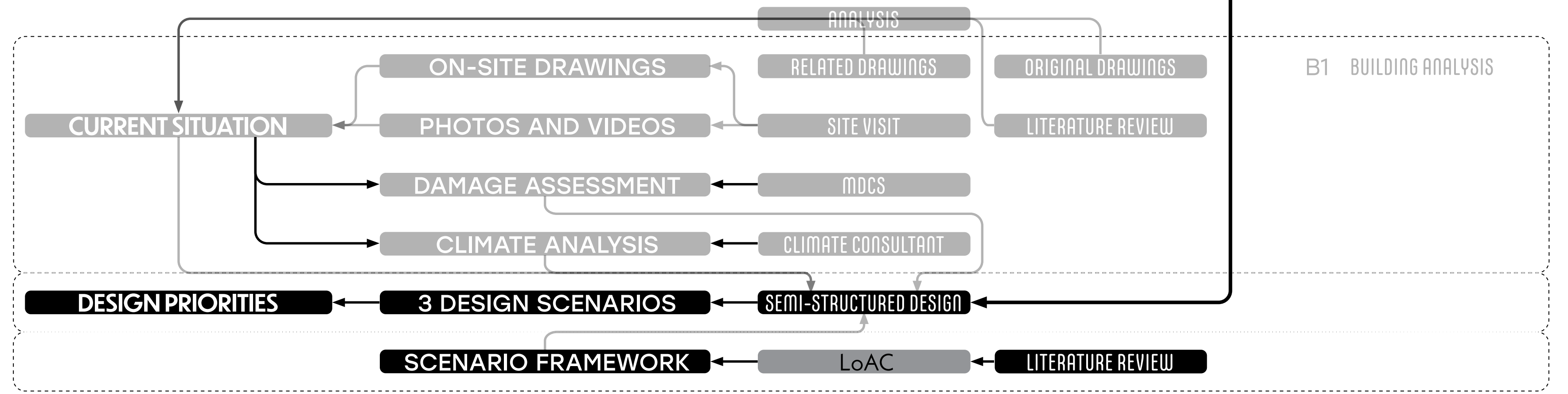

# PART 4 REFLECTION

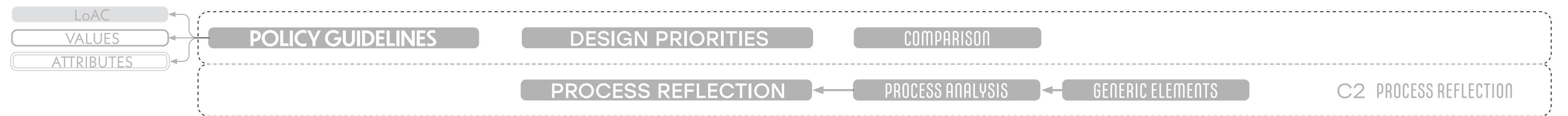

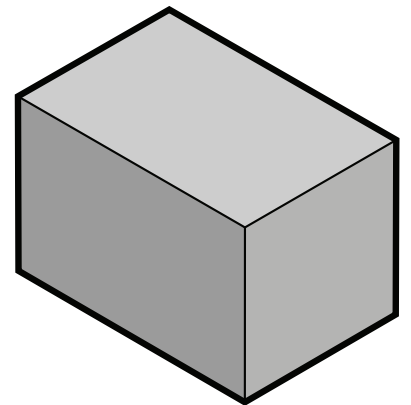
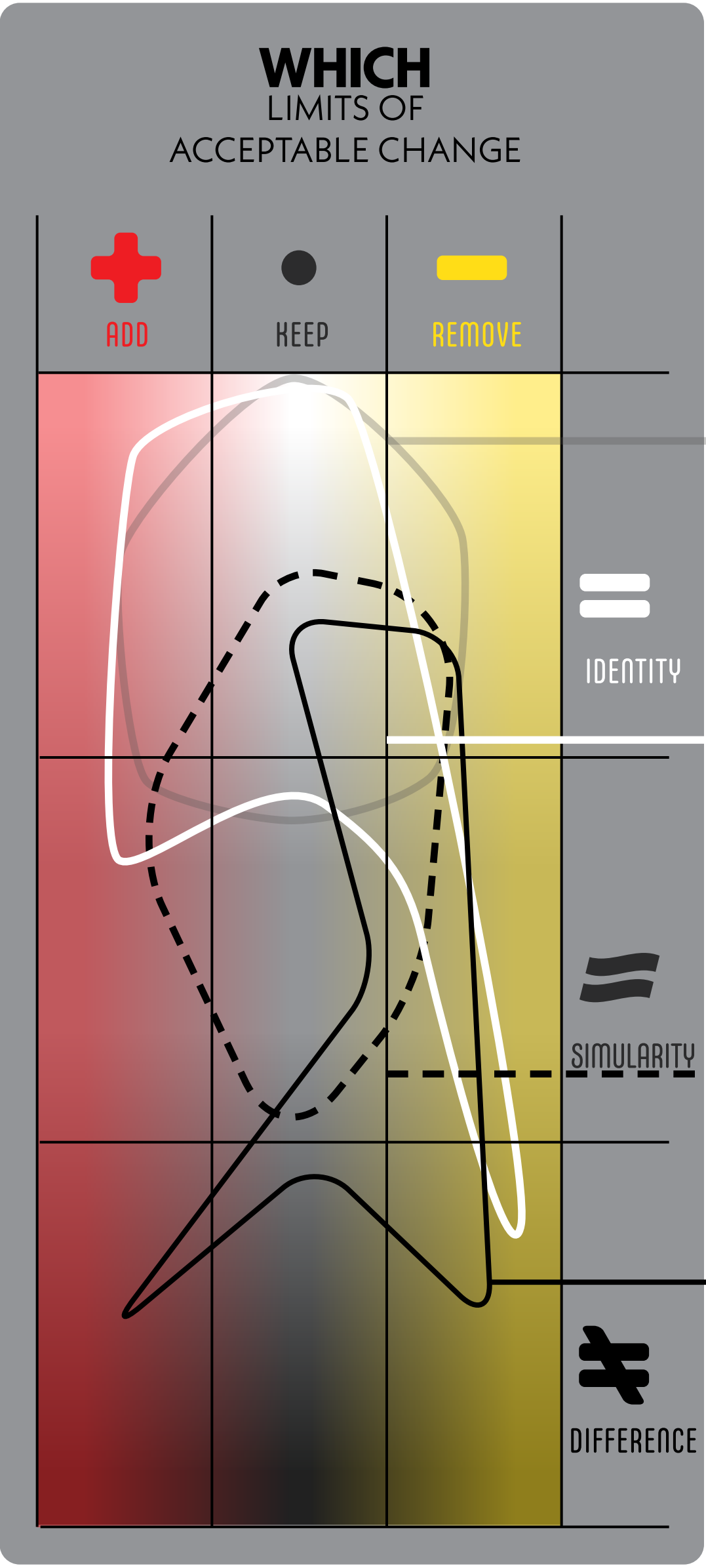

O.CS

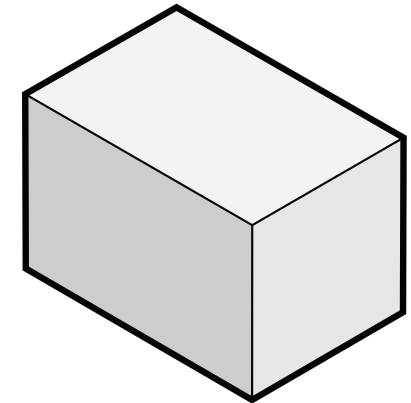

SCENARIO 1.

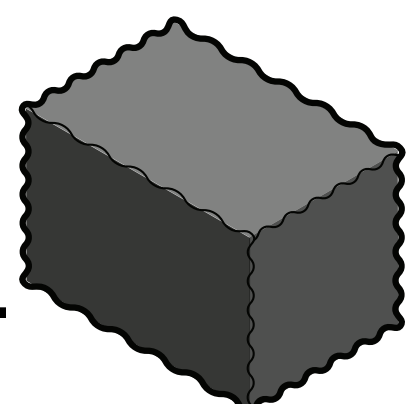

SCENARIO 2.

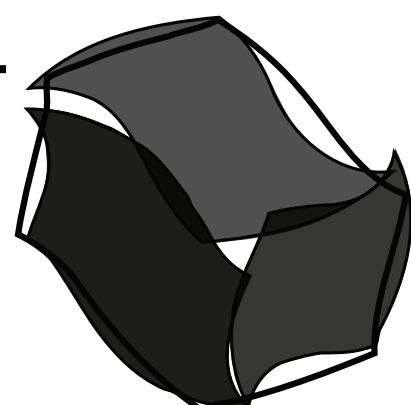

SCENARIO 3.



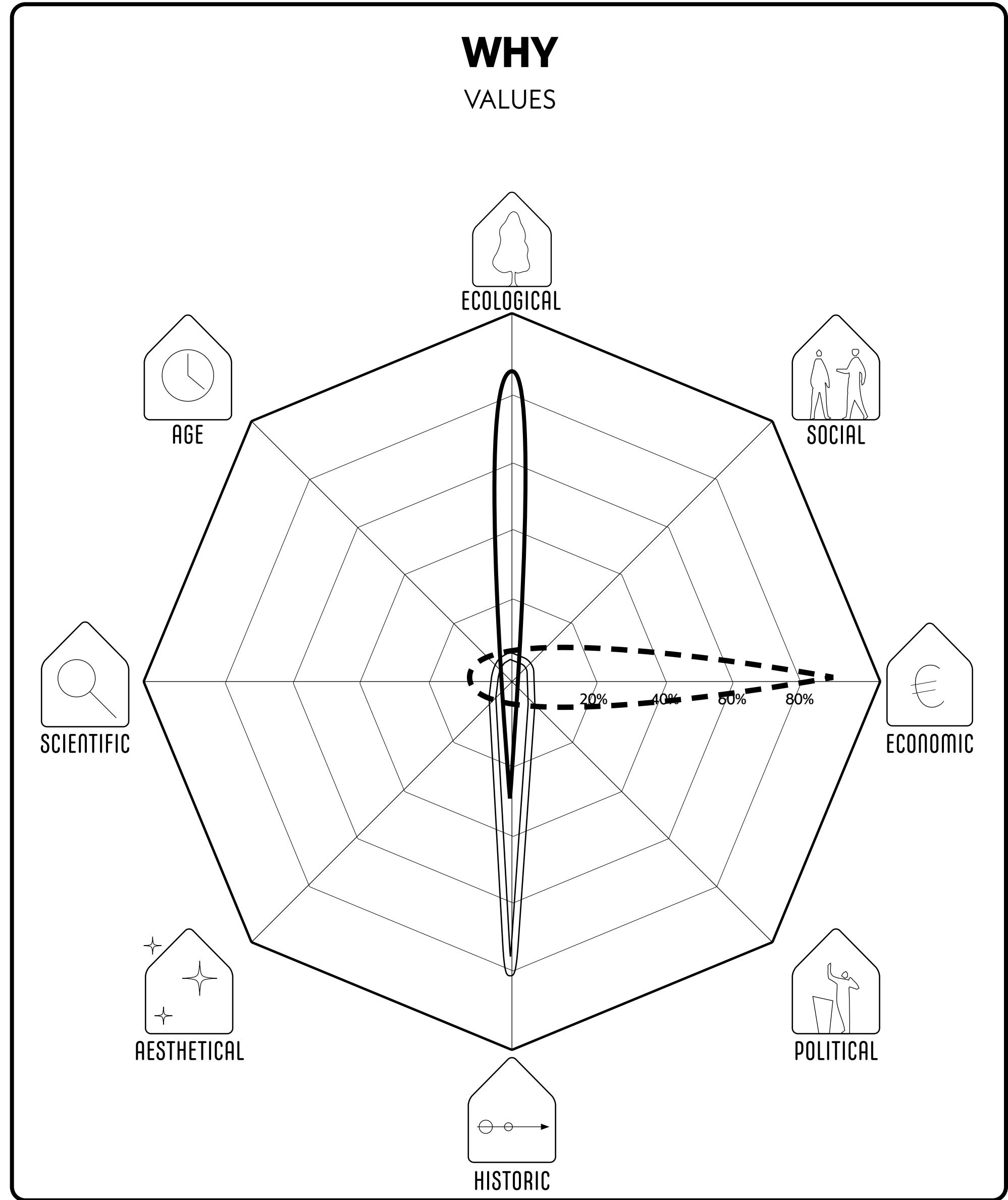
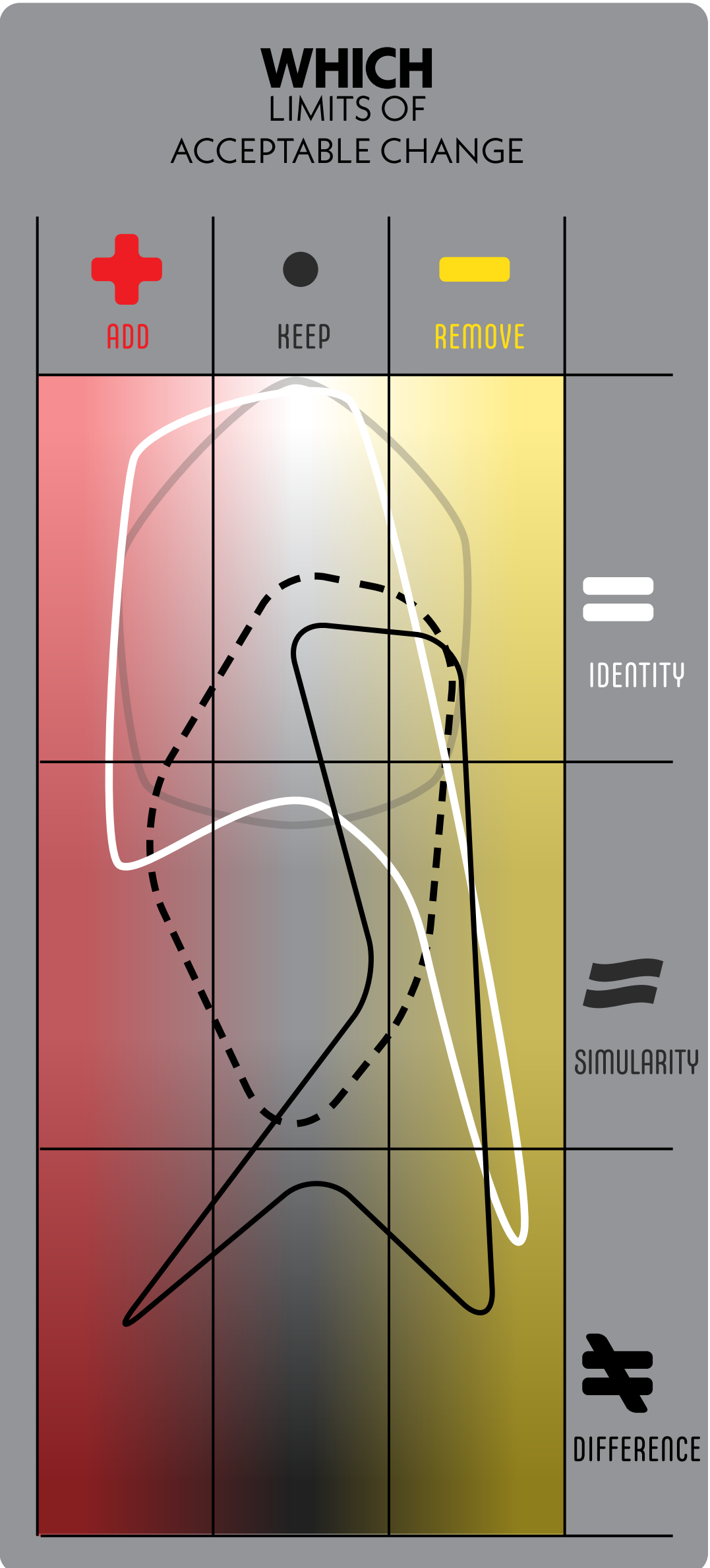

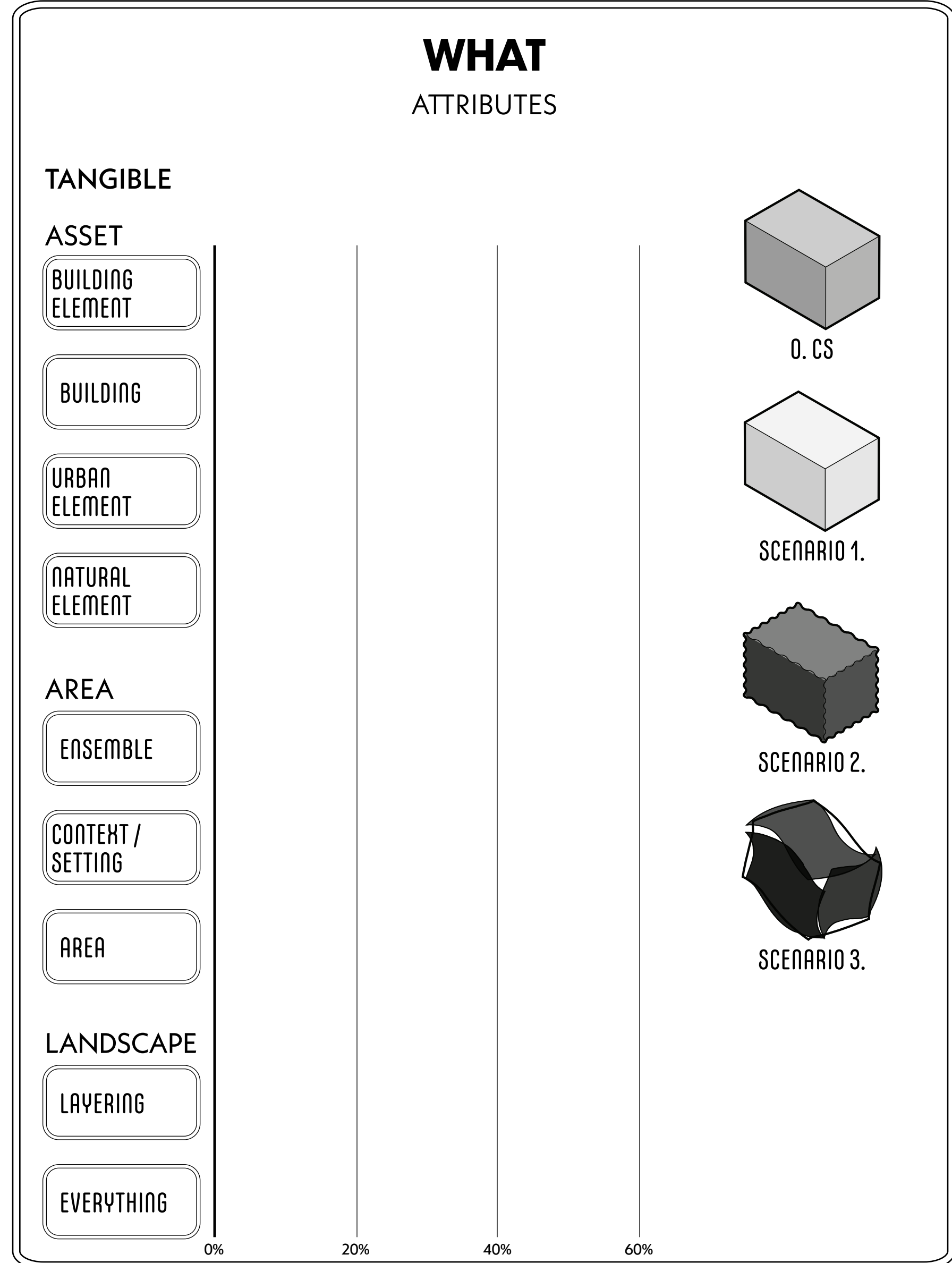
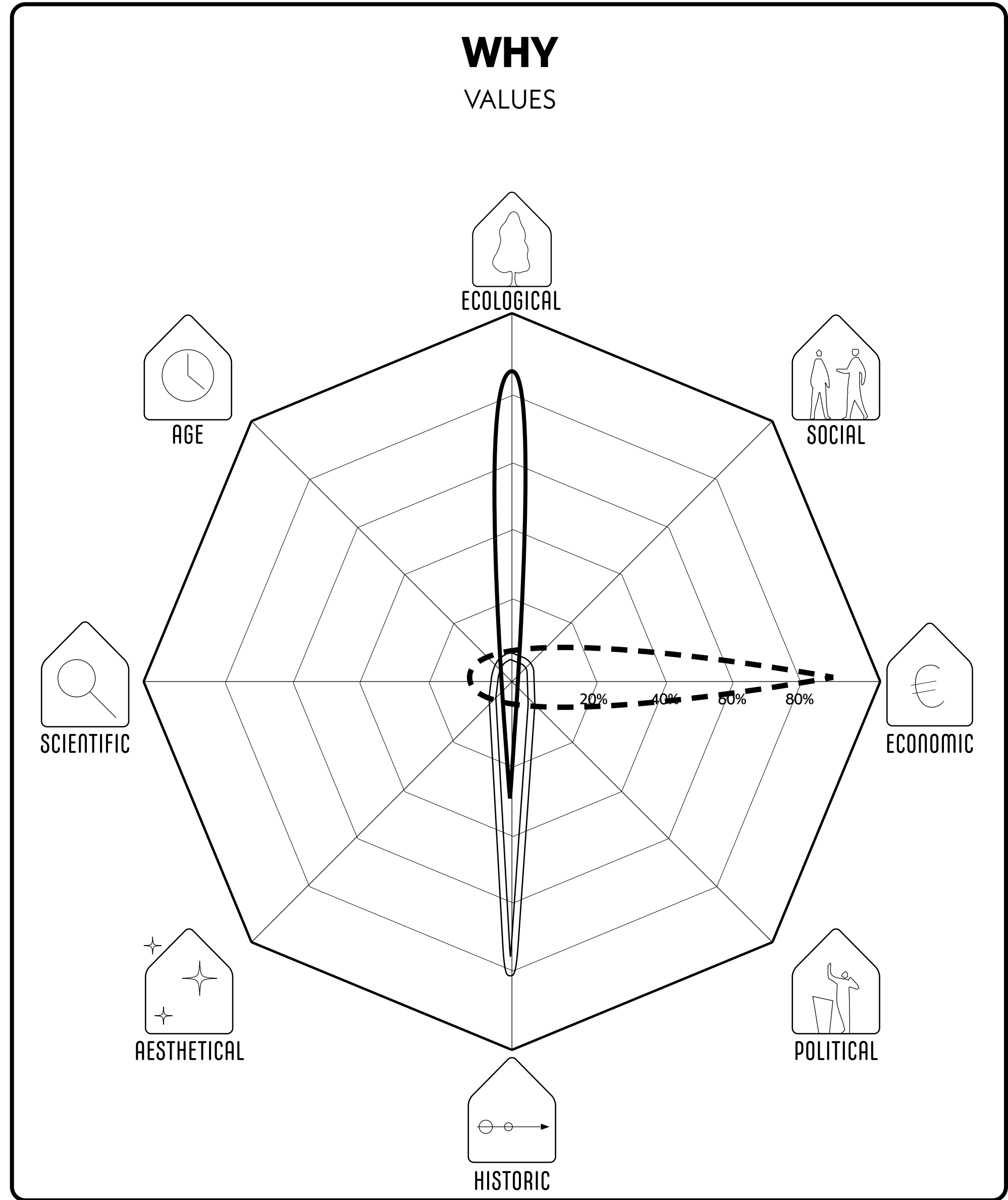
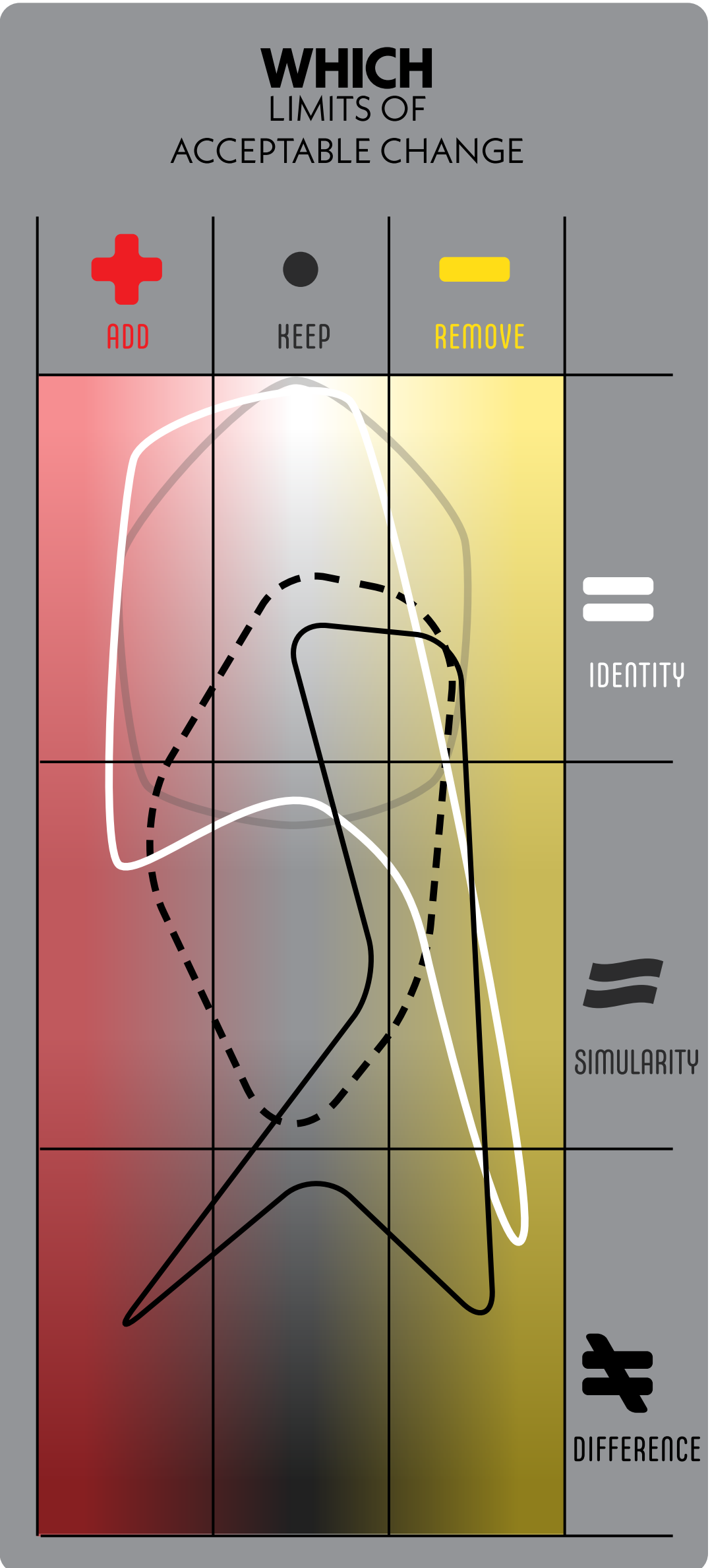

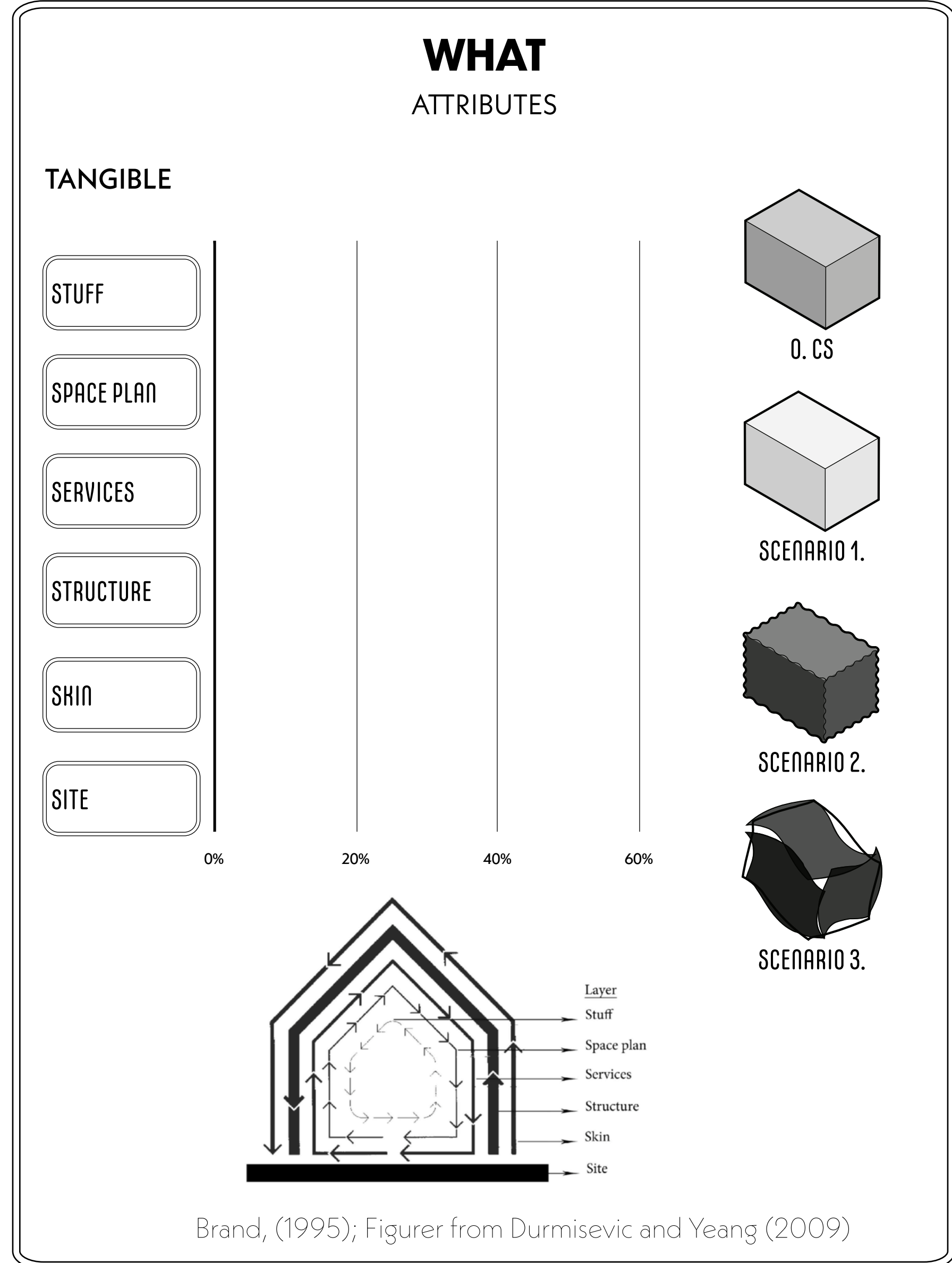
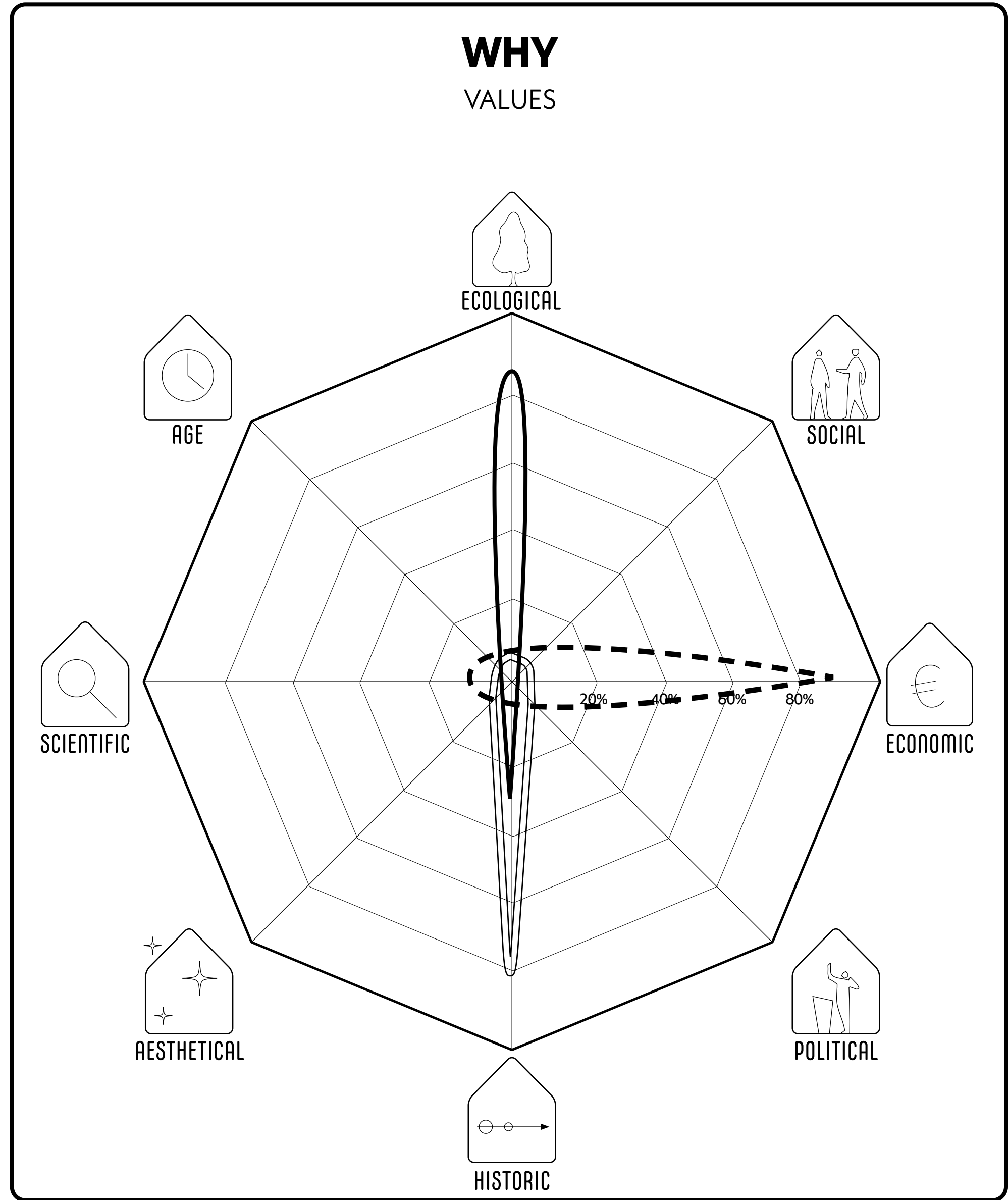
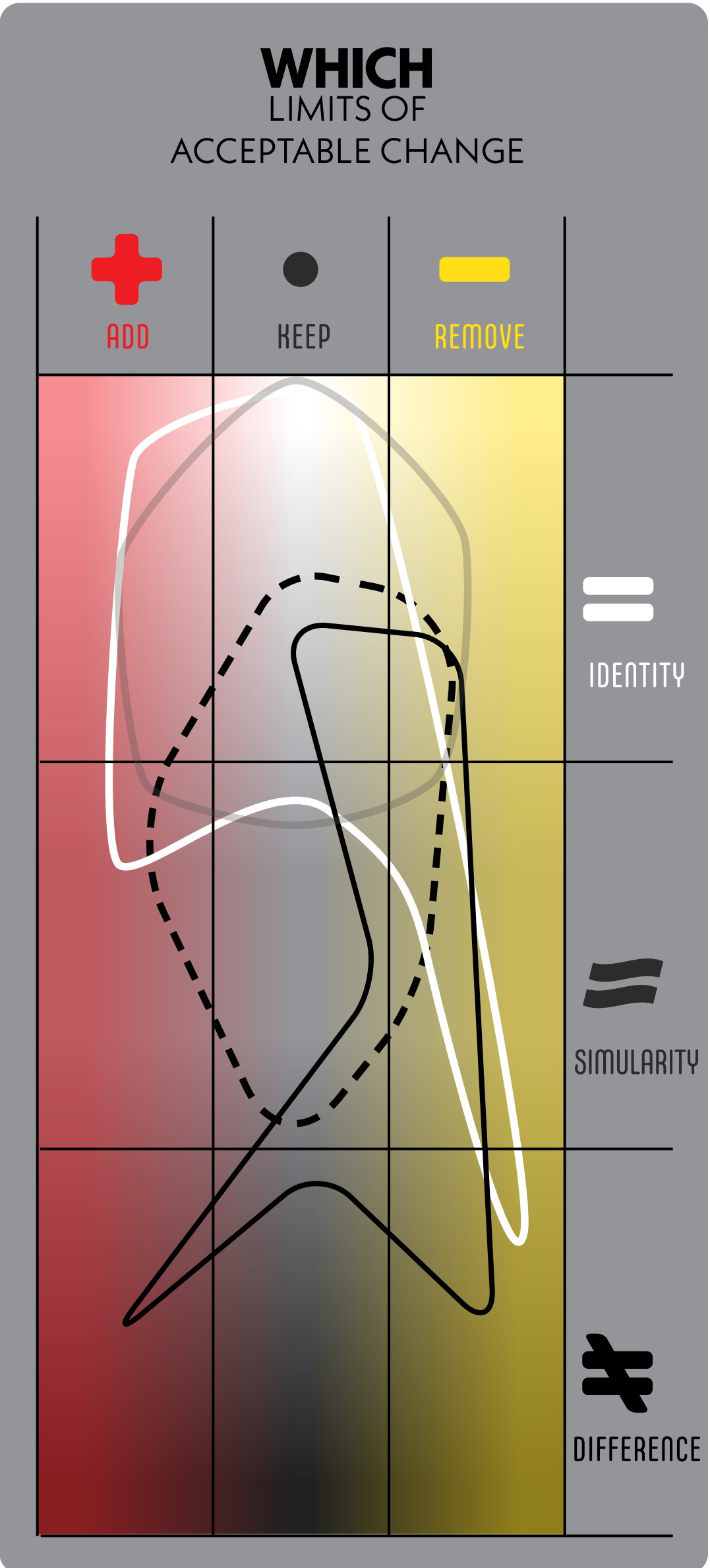



WHICH LIMITS OF ACCEPTABLE CHANGE



ADD



KEEP



REMOVE

IDENTITY

SIMILARITY

DIFFERENCE

WHY

VALUES

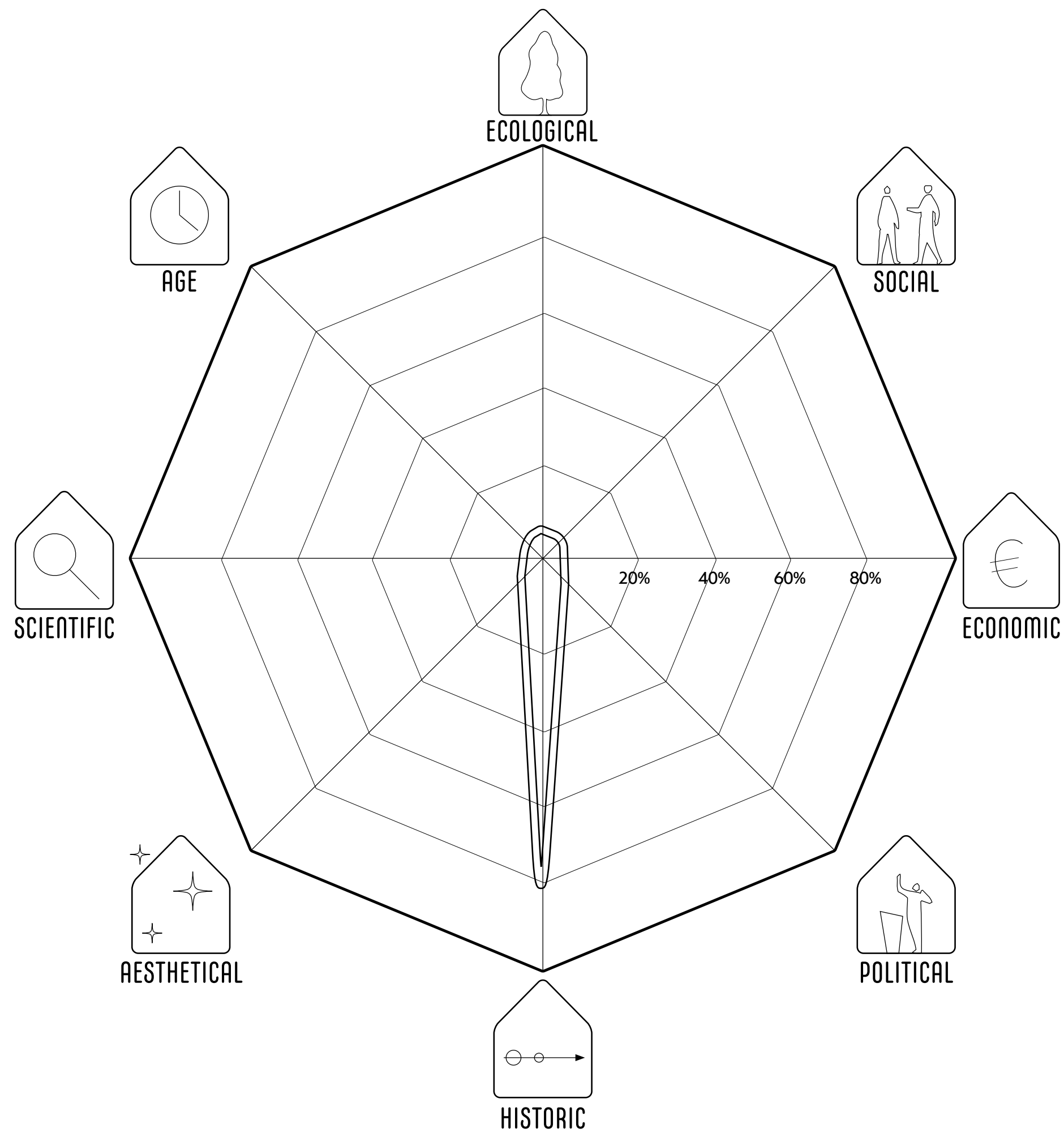

SCENARIO 1.



Disintegration and Replaced:  
Steel eave  
(original concrete eave)



Replaced:  
PVC window frames  
(original wooden window frames)



Disintegration and Cracking:  
White plaster on concrete



Paint damage:  
Original wooden window frames

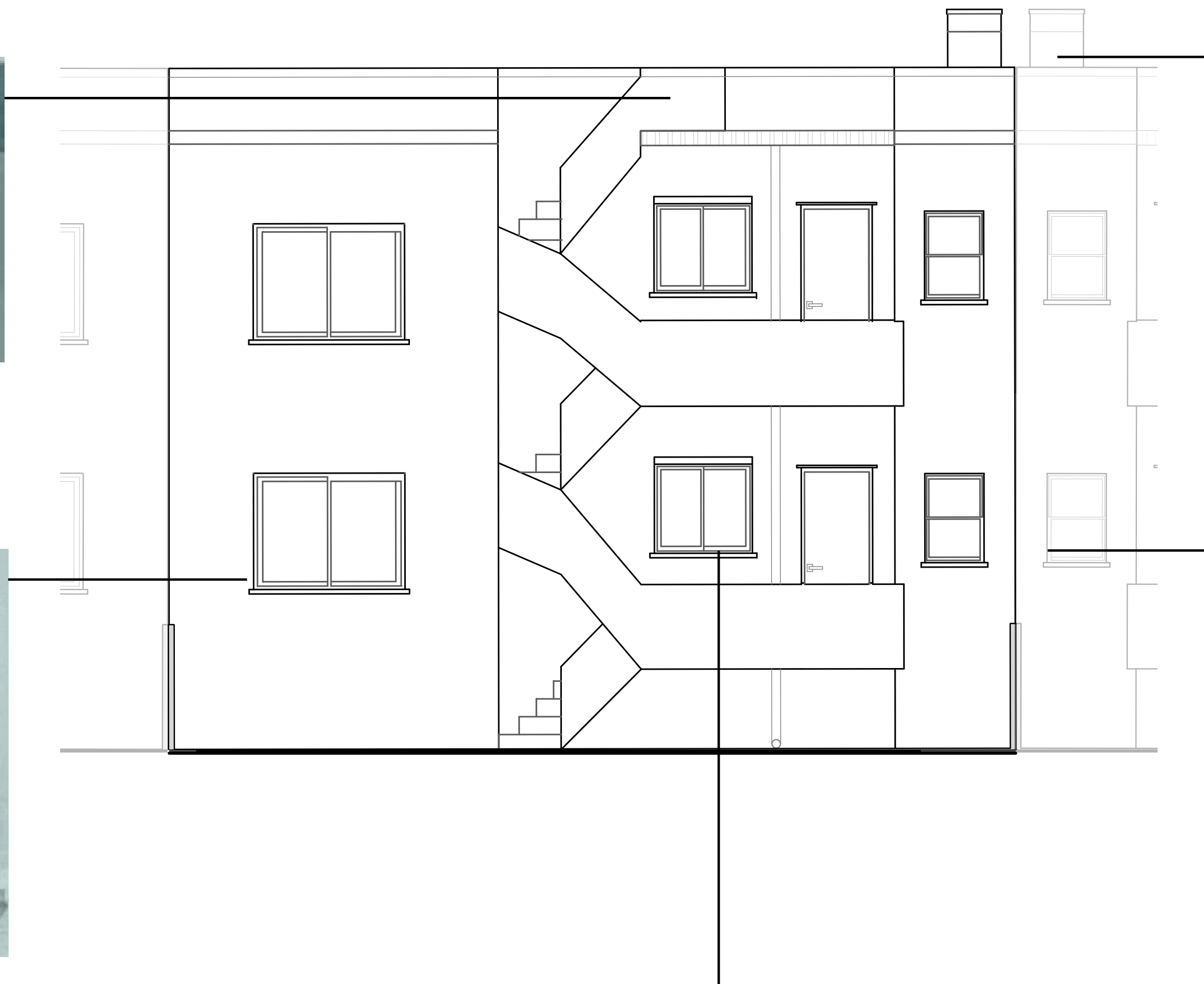



Replaced:  
PVC window frames and shutters  
(original wooden window frames and shutters)



Replaced:  
PVC window shutters  
(original wooden window shutters)



Original



Current Situation

Replaced:  
Water connection and grey plaster  
(Original greenplaster)

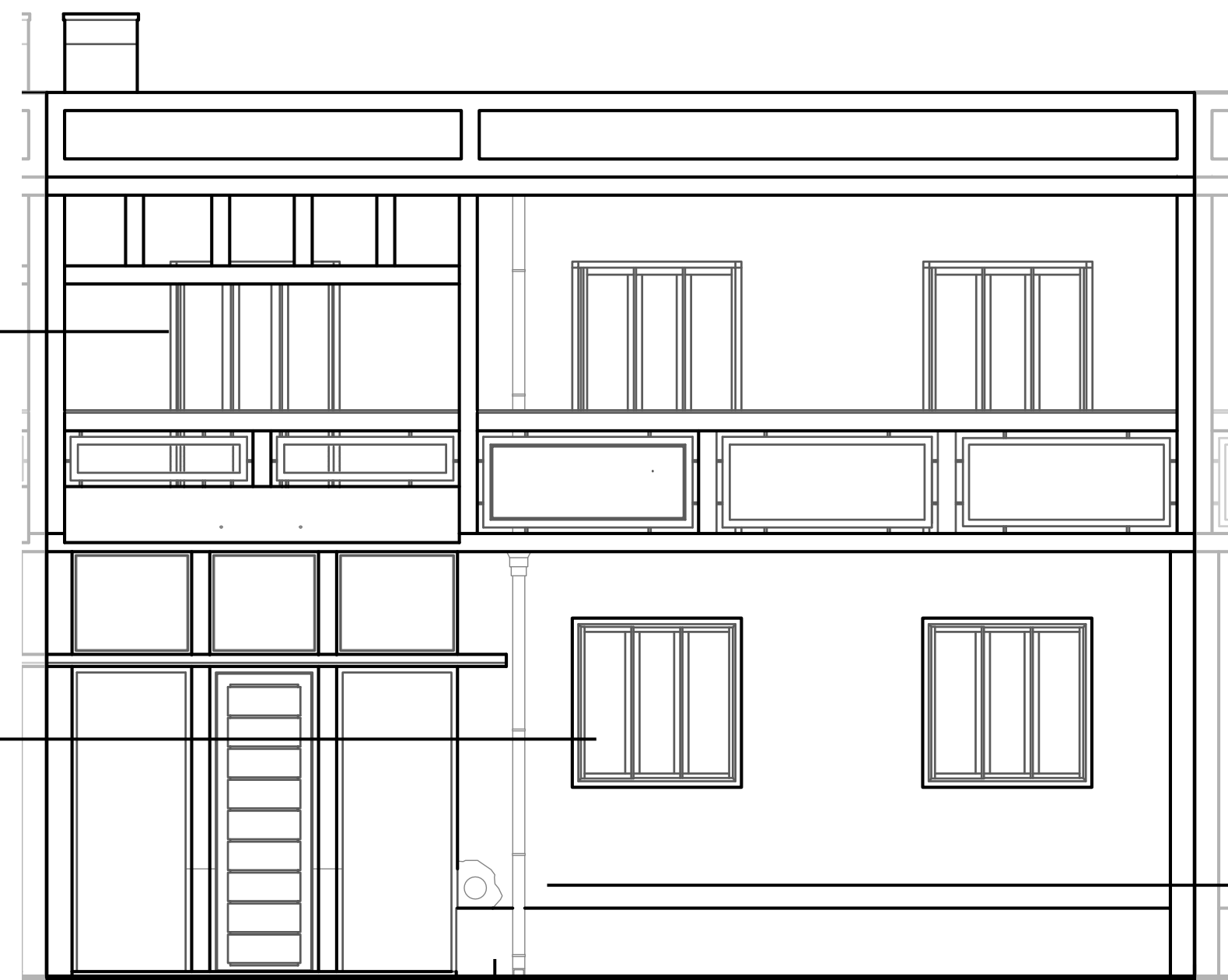

Disintegration and Cracking:  
White plaster on concrete

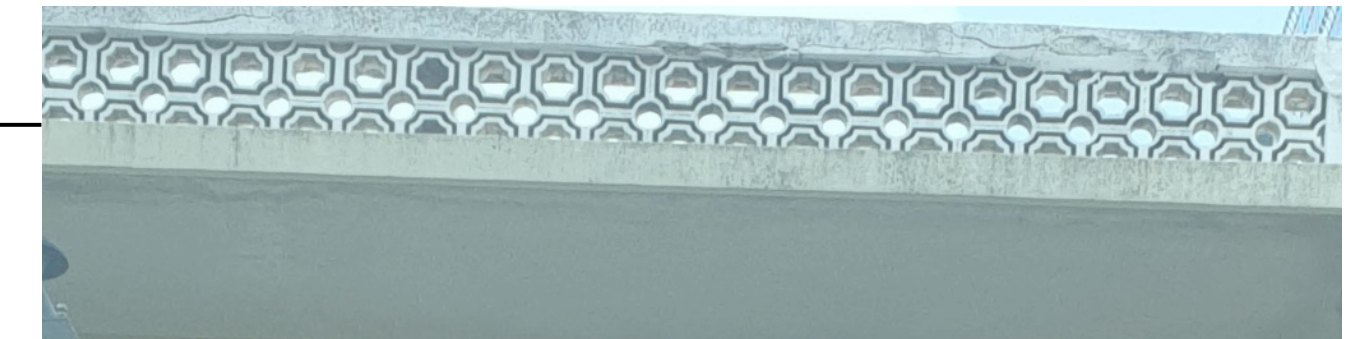

Moist spots:  
White plaster on concrete

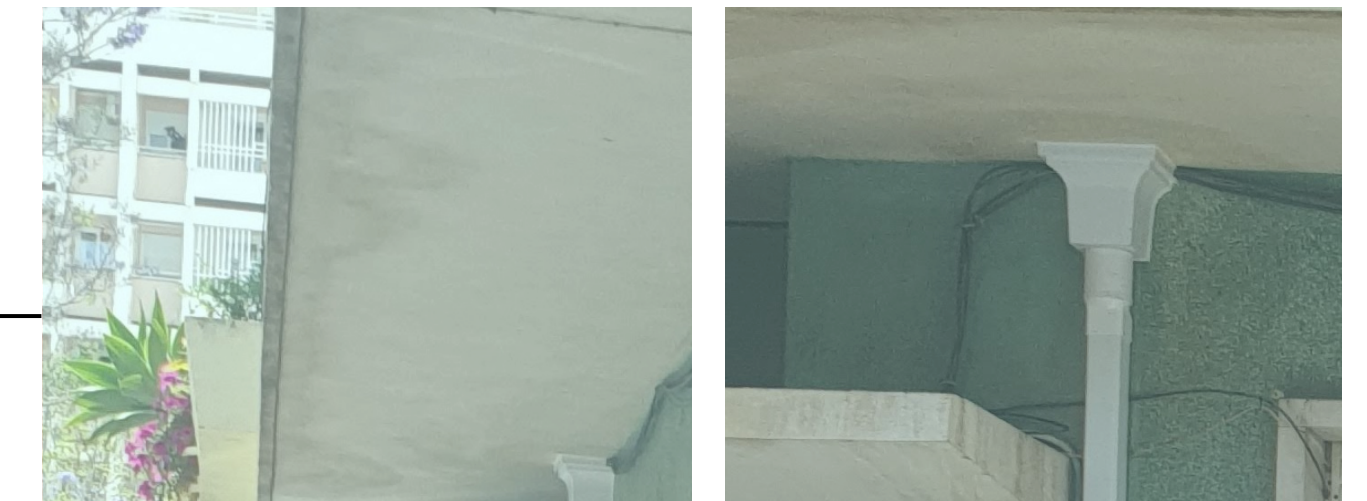

Replaced:  
PVC rain-pipe  
(Original steel rain-pipe)



Current Situation



Original



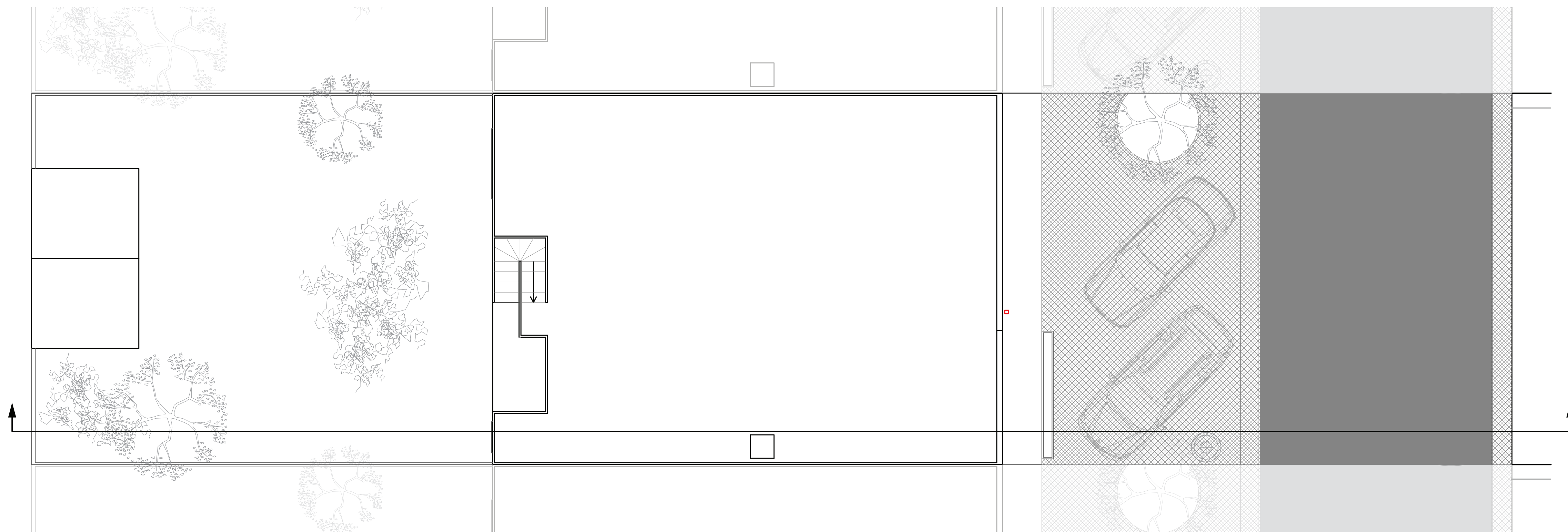



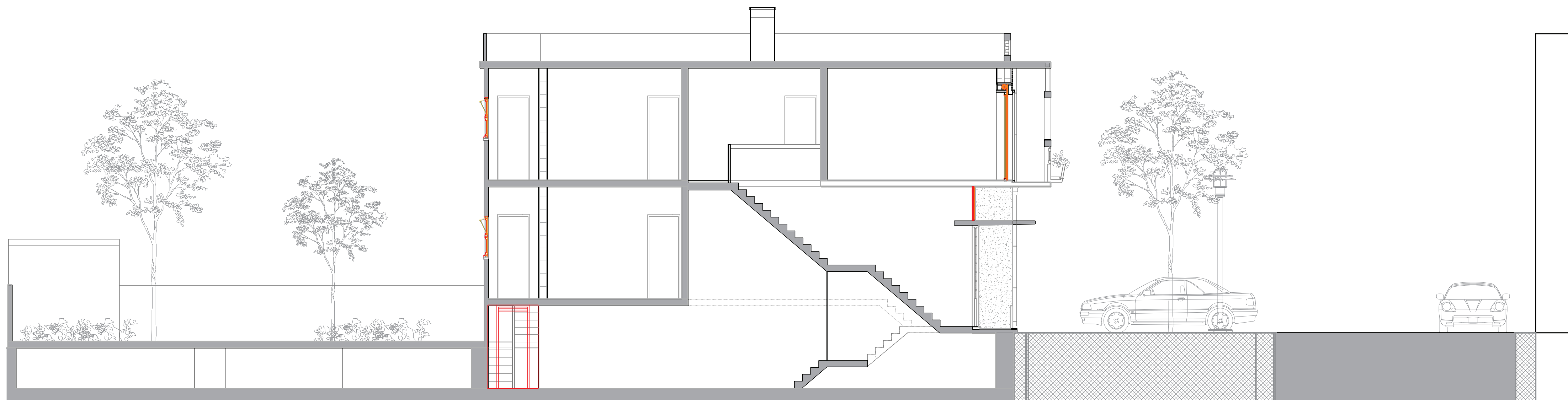

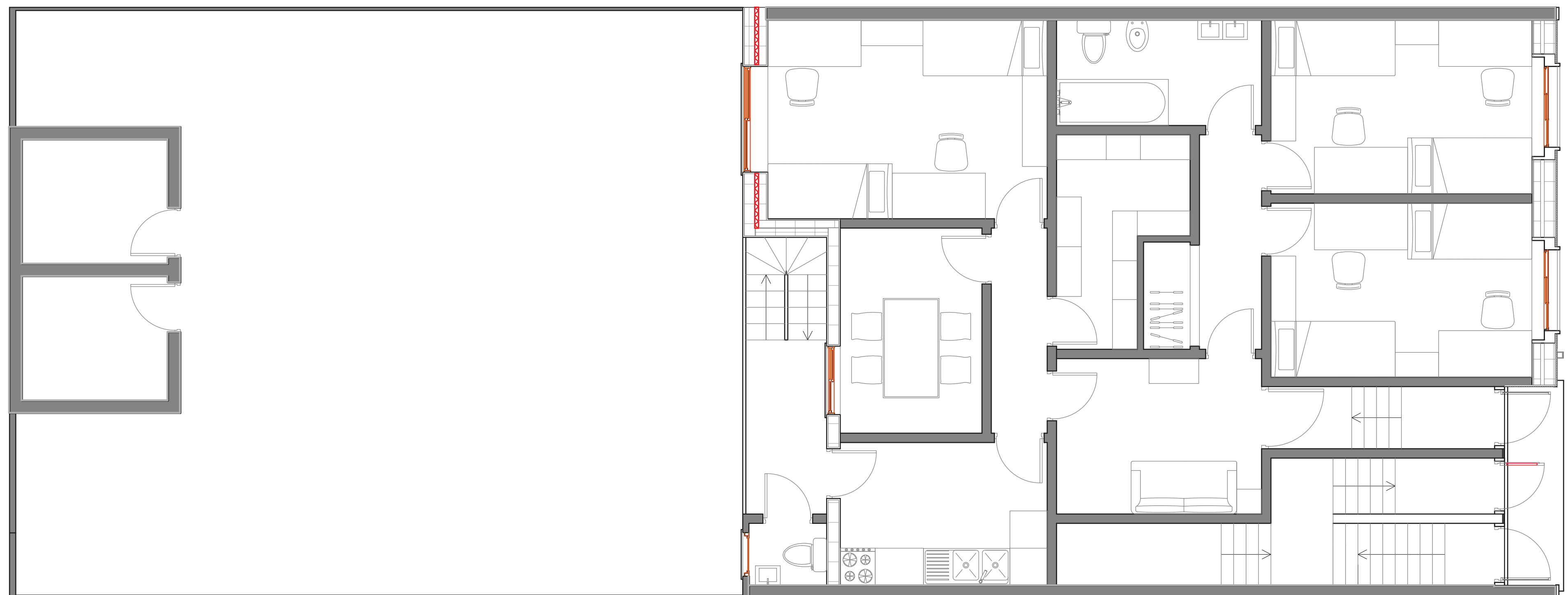

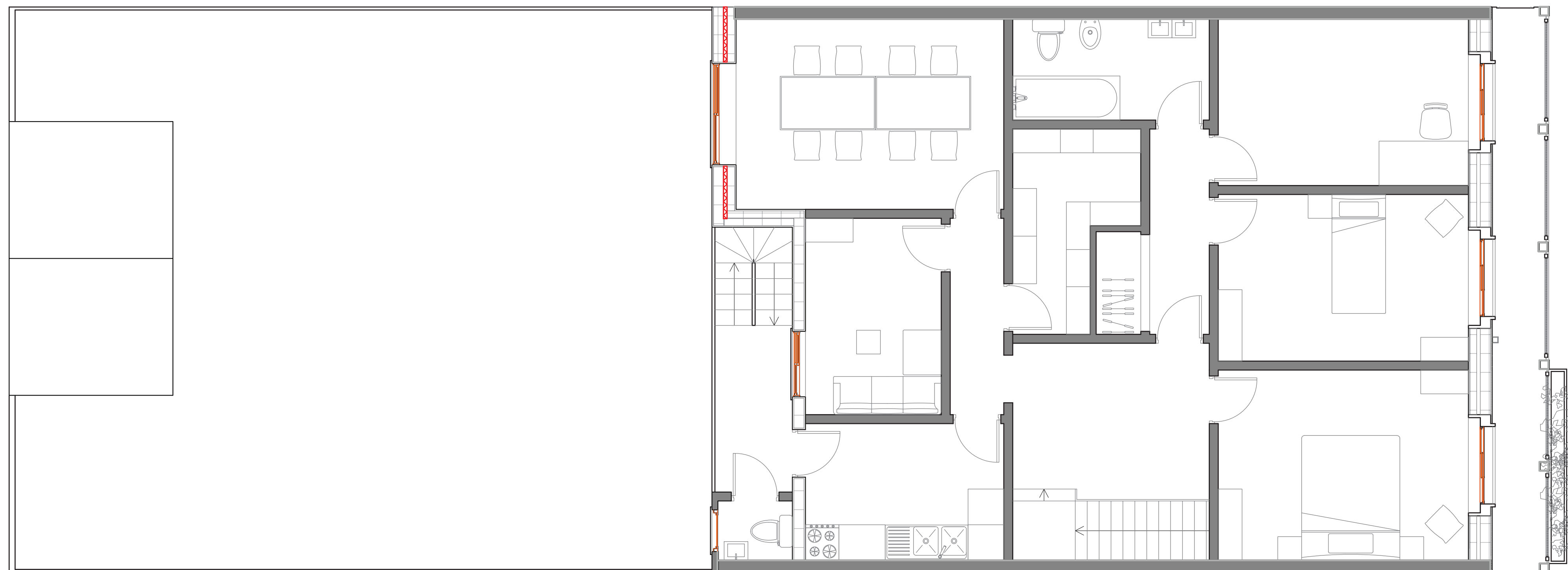







### WHICH LIMITS OF ACCEPTABLE CHANGE

ADD	KEEP	REMOVE	
			IDENTITY
			SIMILARITY
			DIFFERENCE

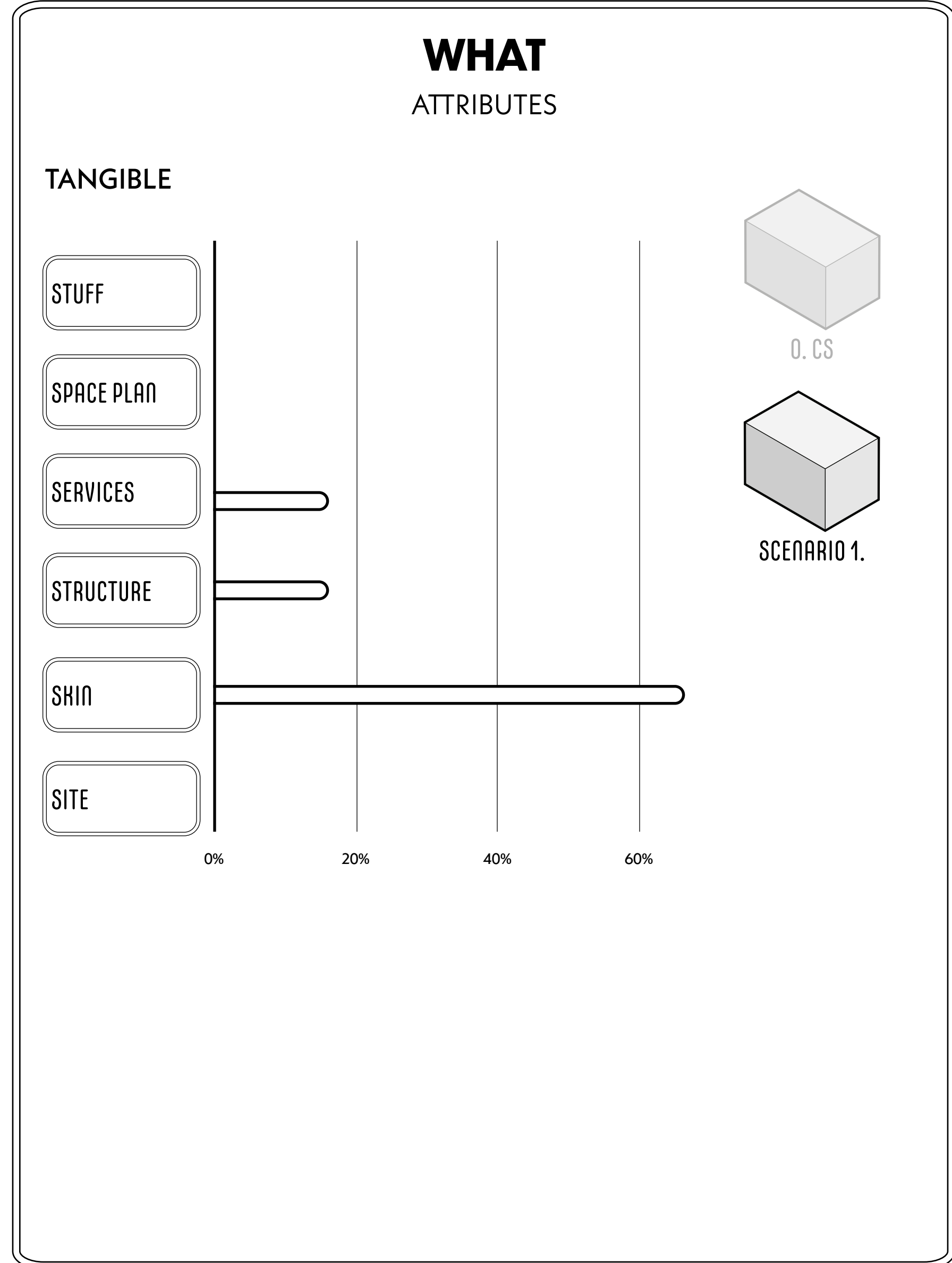
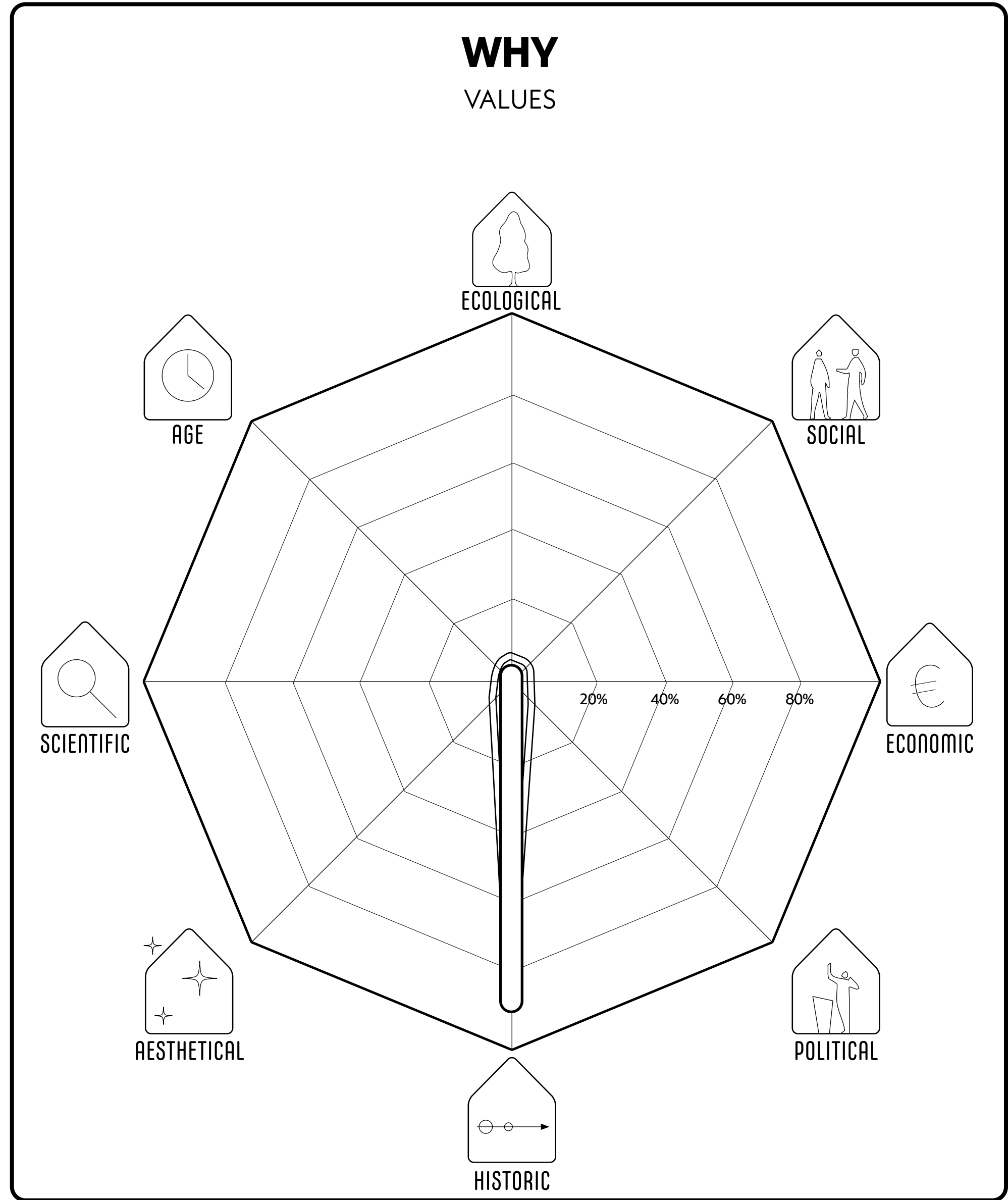



**WHICH**  
LIMITS OF  
ACCEPTABLE CHANGE

+	●	-	
ADD	KEEP	REMOVE	
[Red to Yellow Gradient]	[Yellow to Grey Gradient]	[Yellow to Green Gradient]	= IDENTITY
			≐ SIMILARITY
[Red to Grey Gradient]	[Grey to Green Gradient]	[Green to Yellow Gradient]	≠ DIFFERENCE

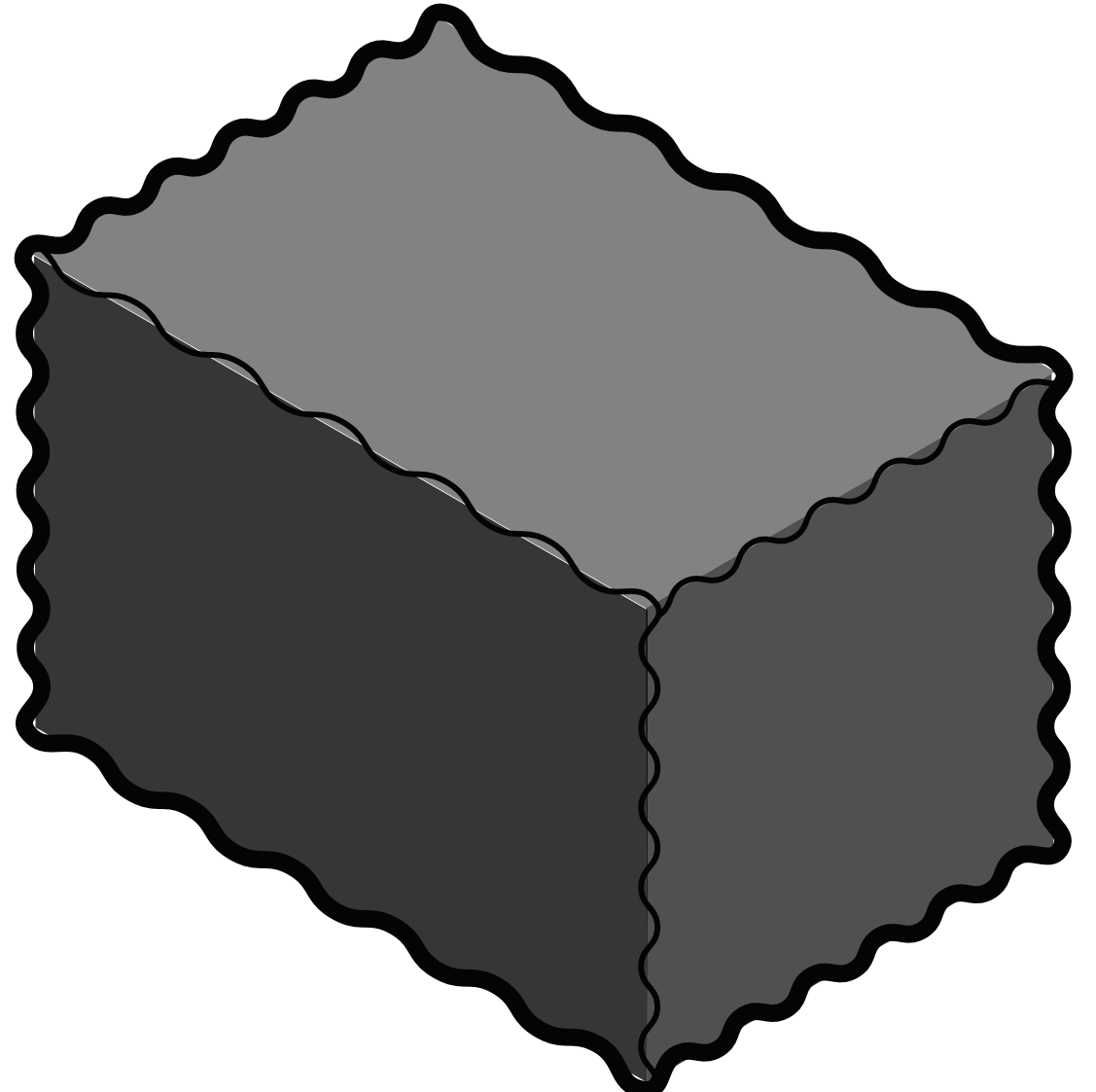
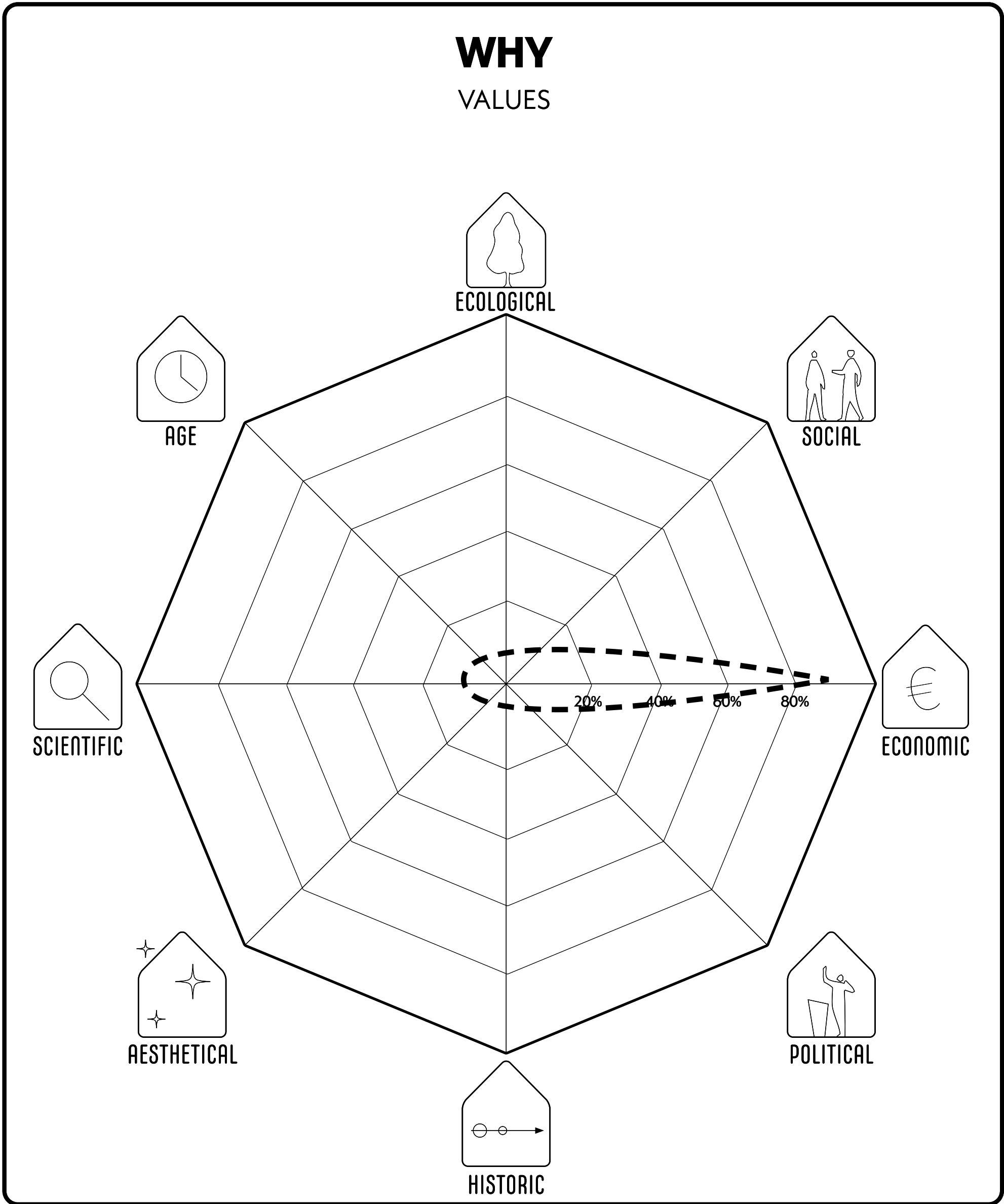

**SCENARIO 2.**

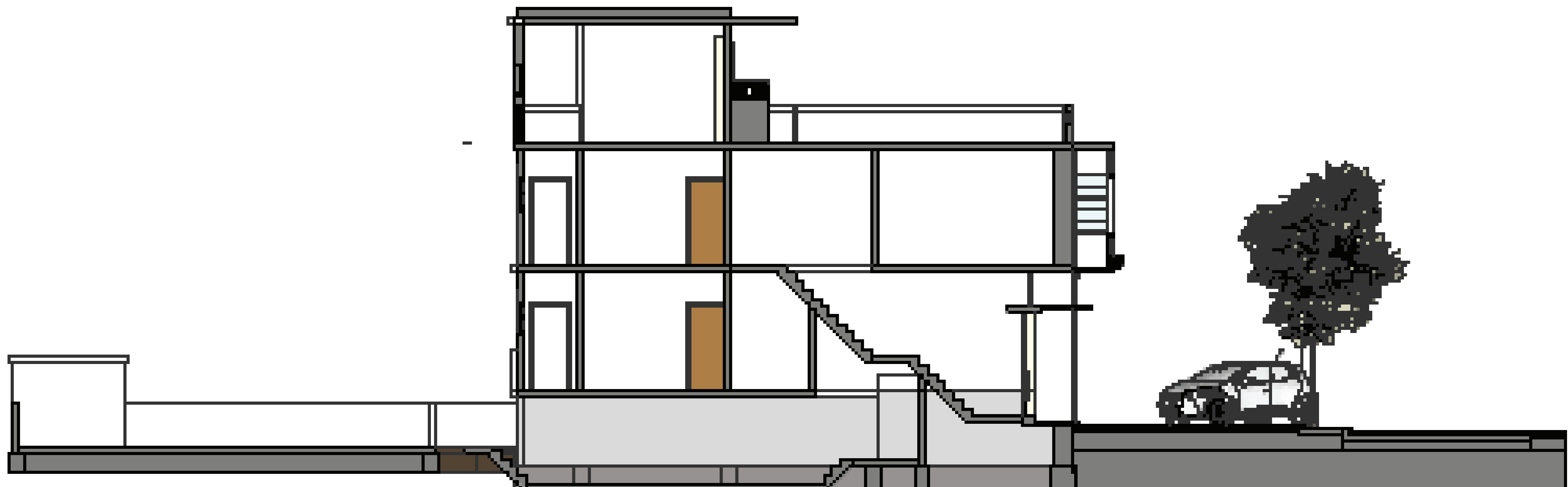





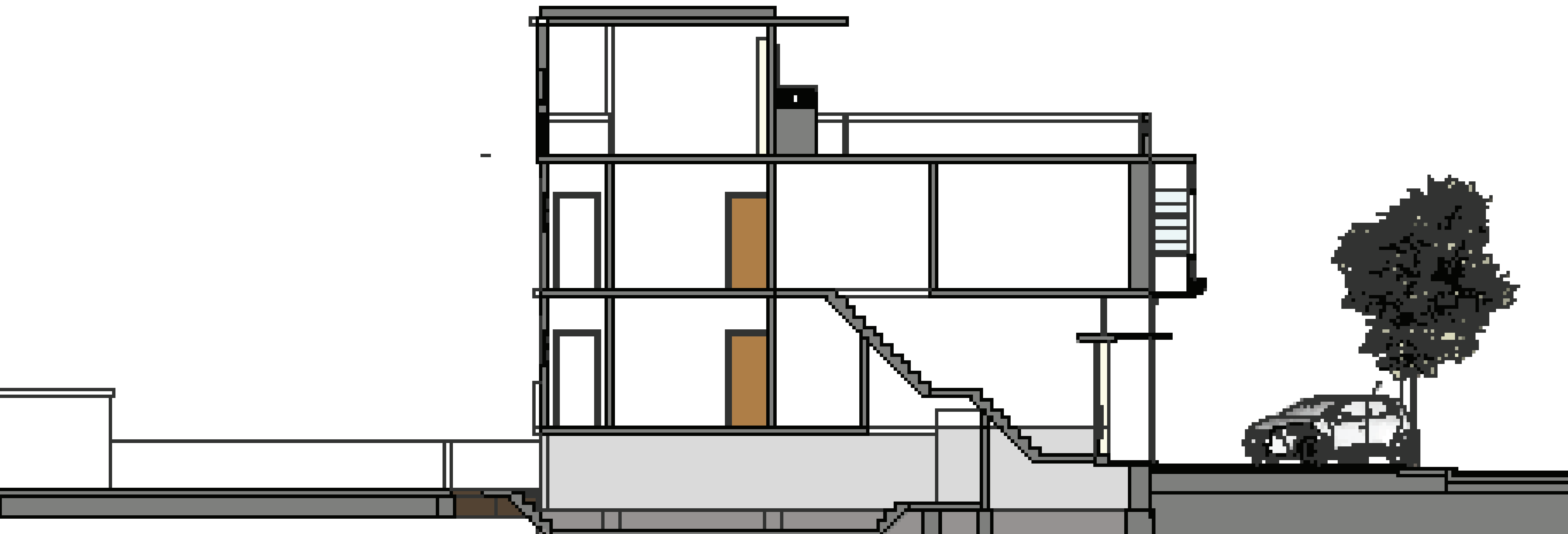

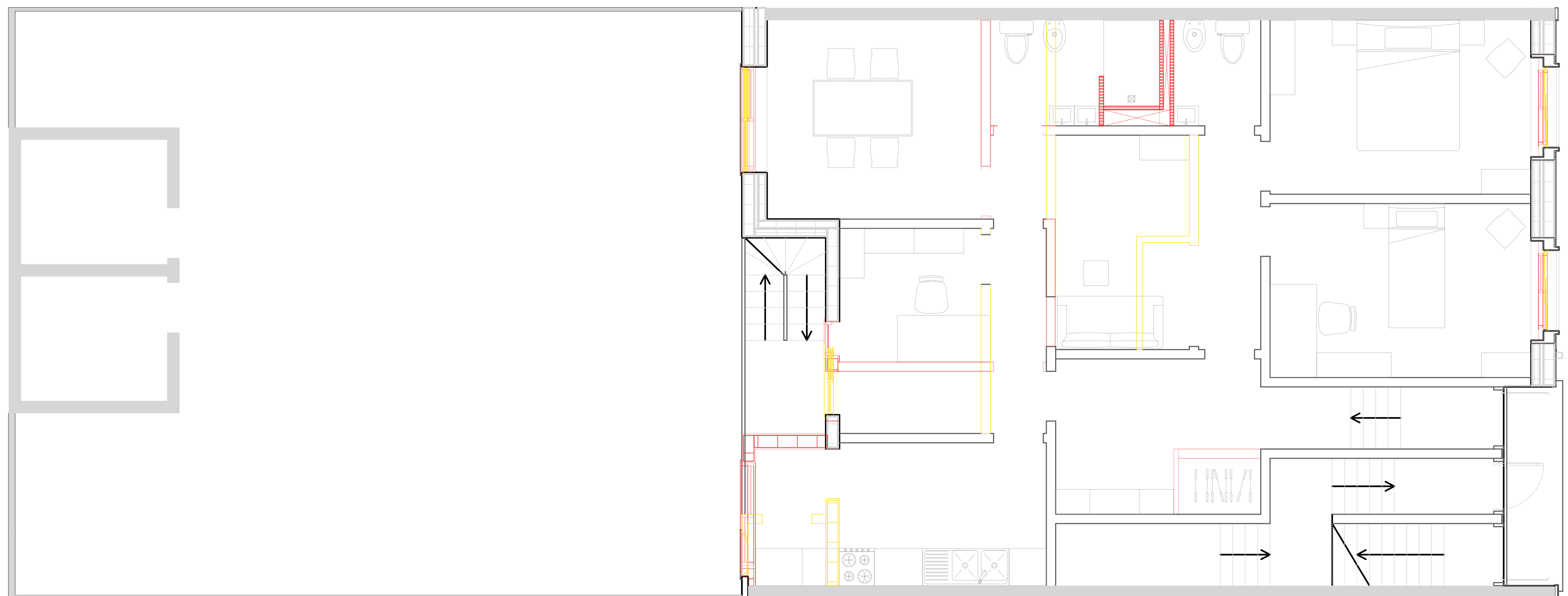

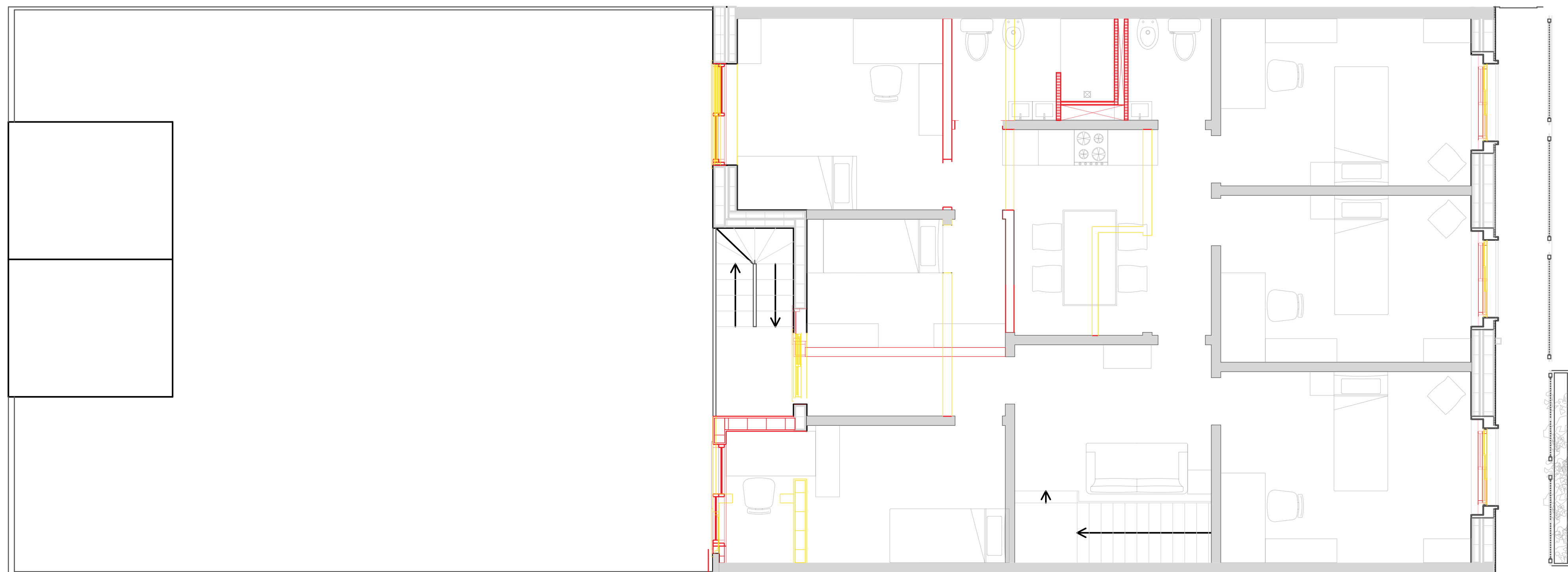

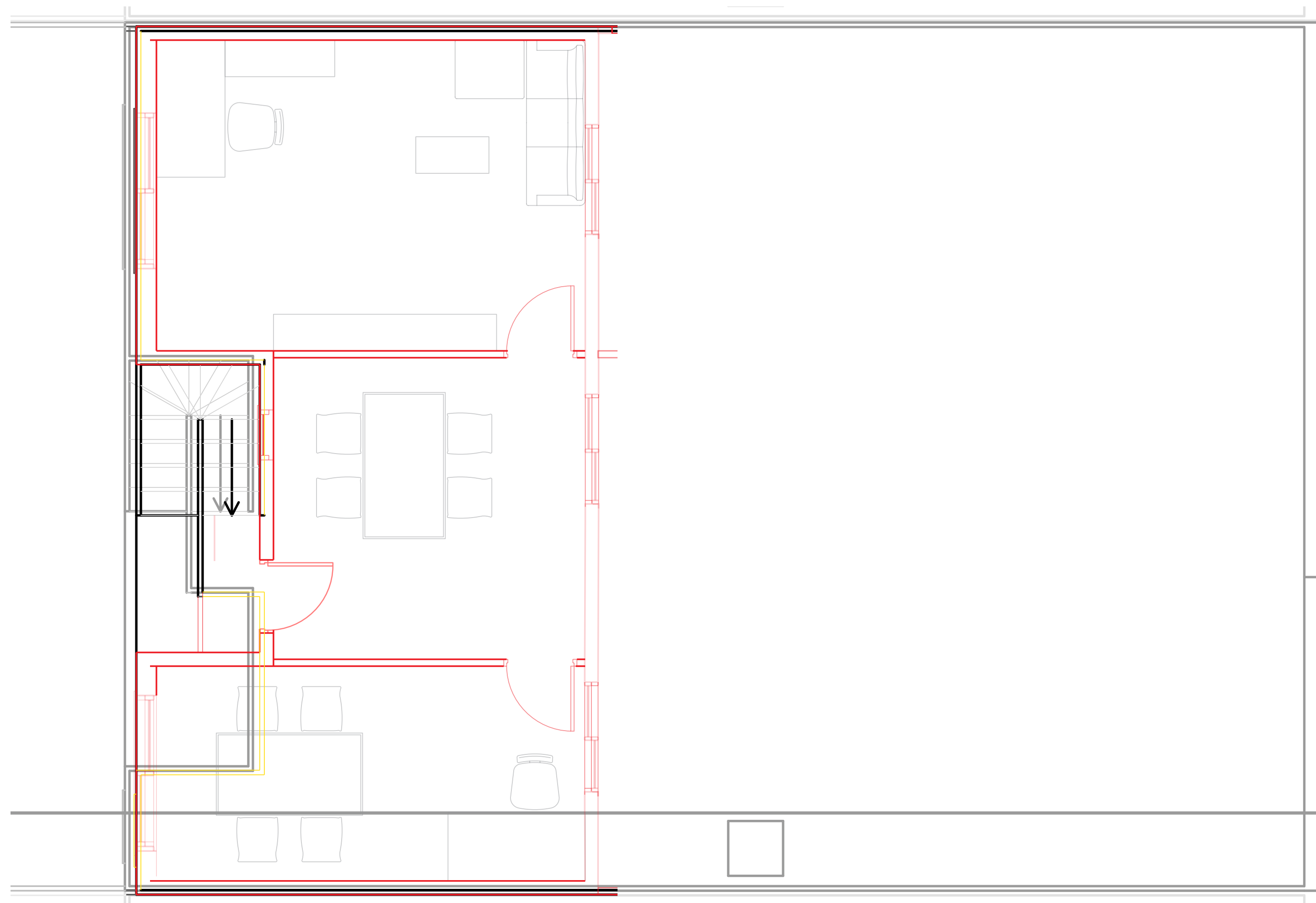





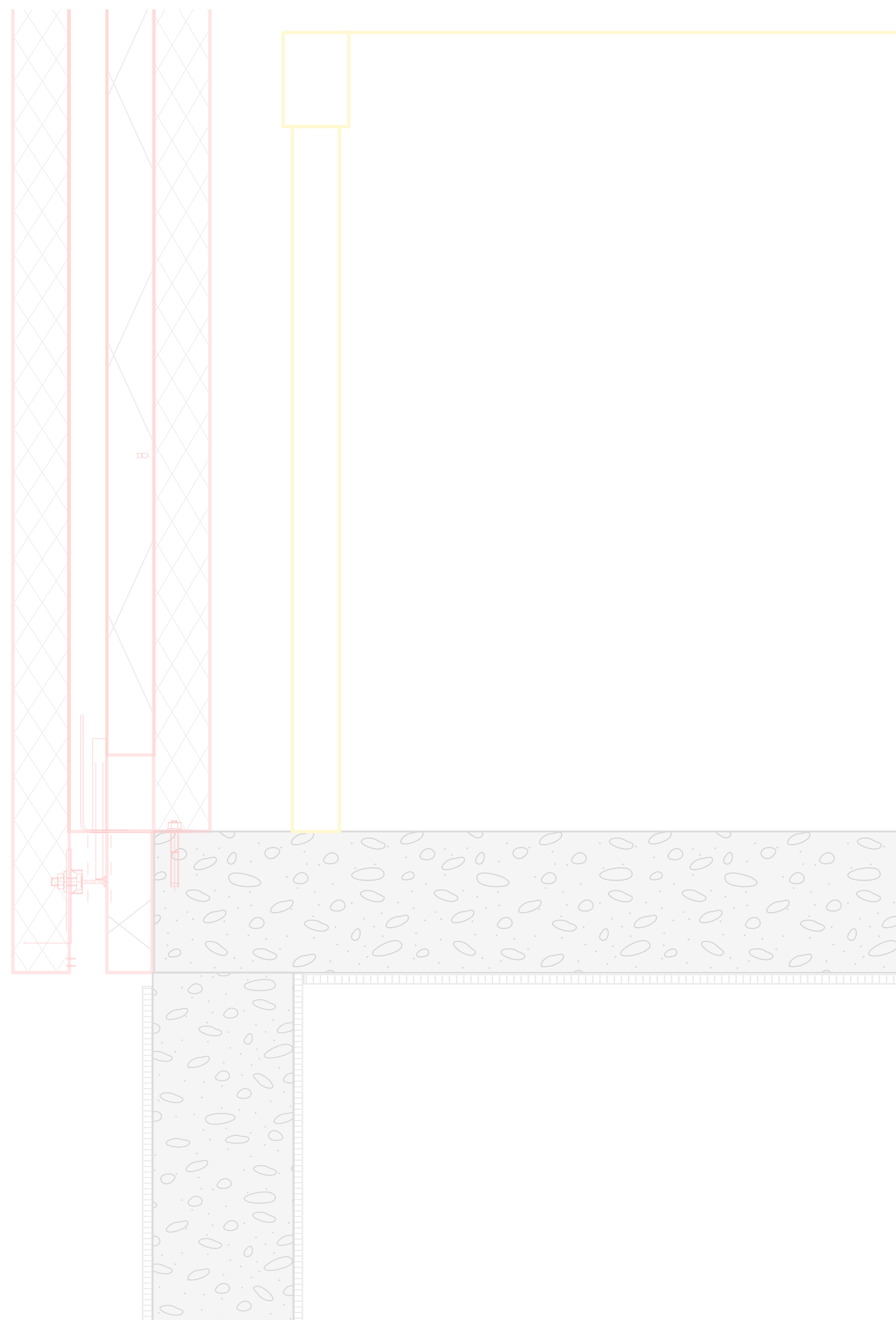





### WHICH LIMITS OF ACCEPTABLE CHANGE

ADD	KEEP	REMOVE	

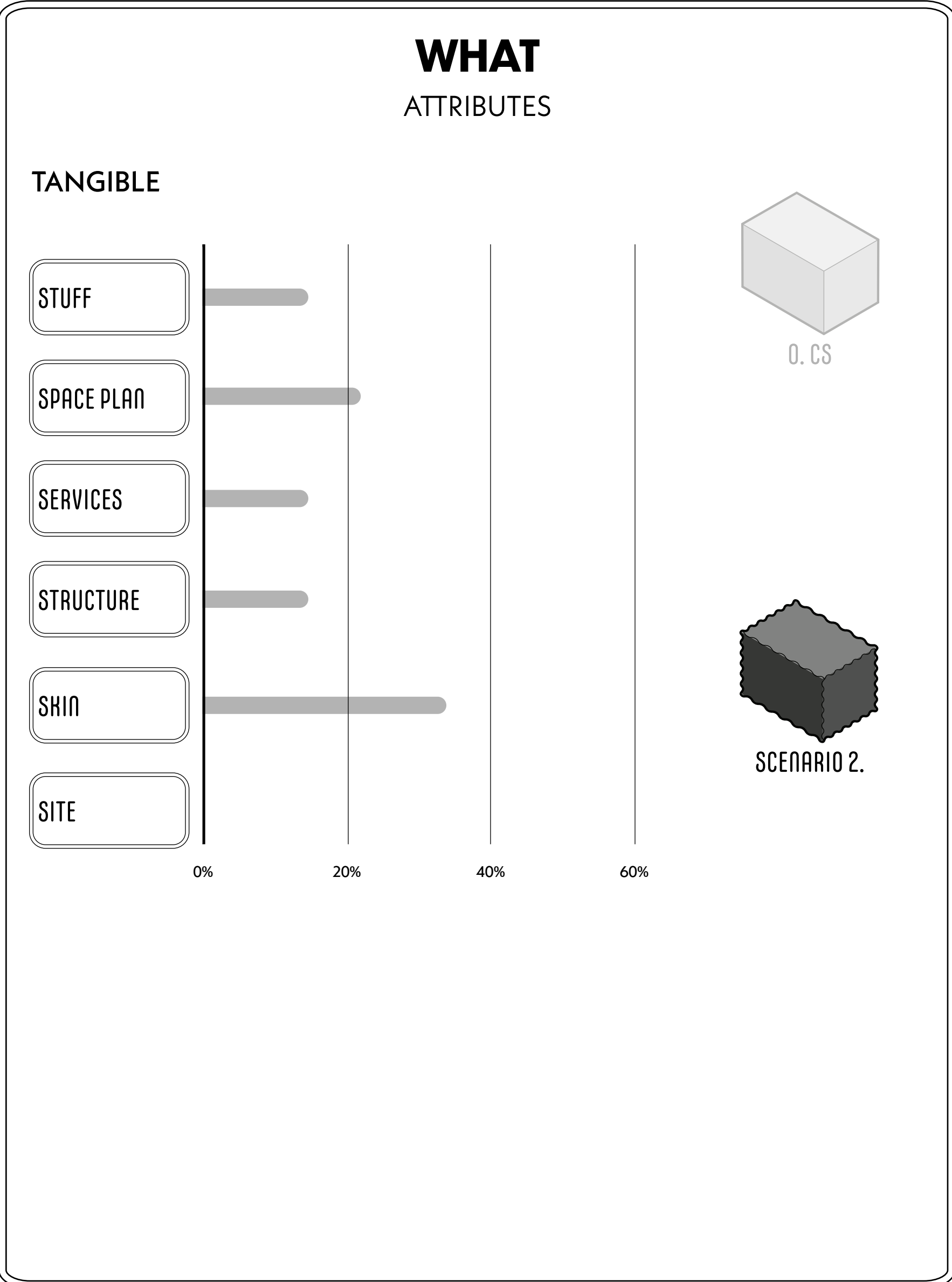
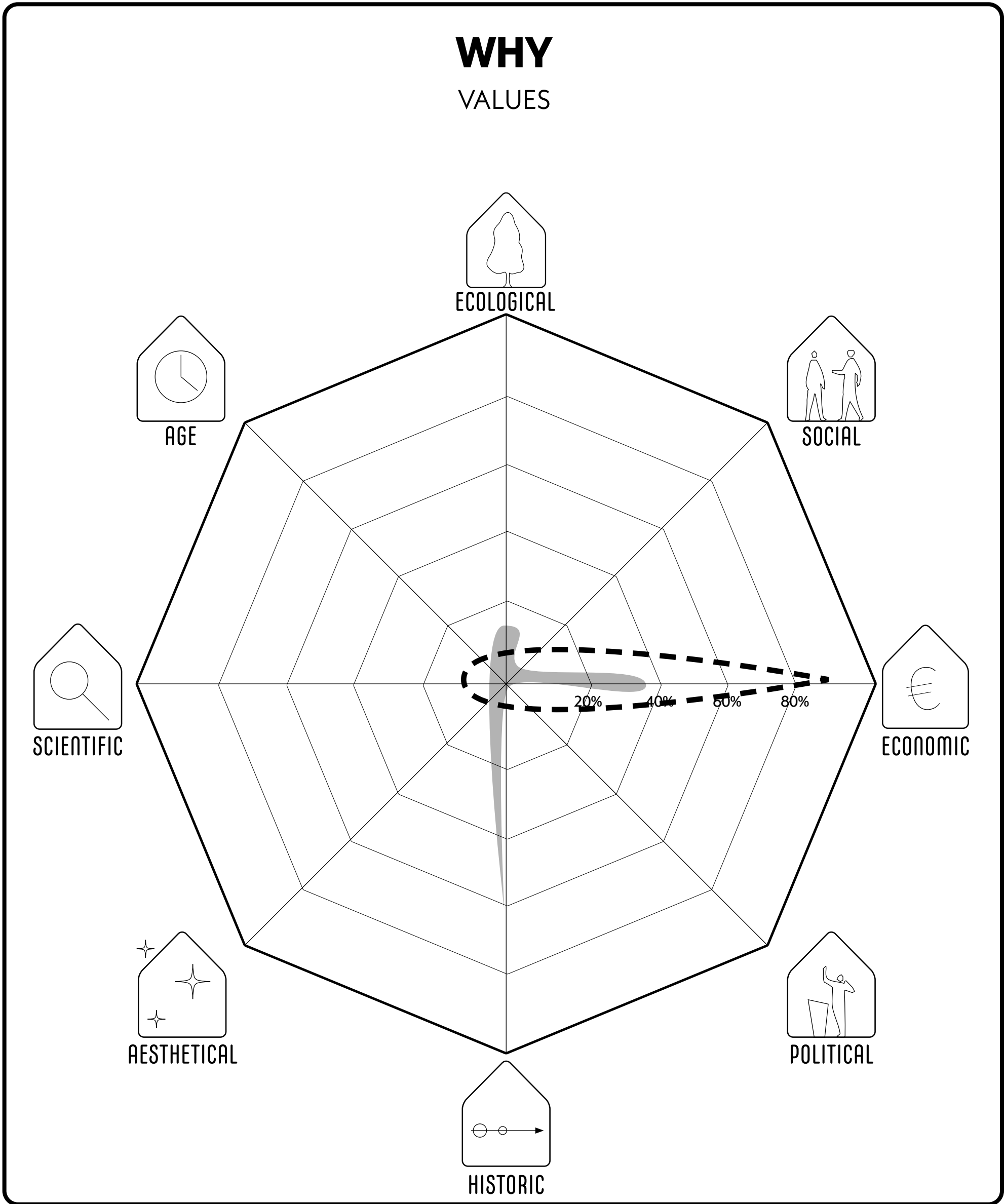



**WHICH**  
LIMITS OF  
ACCEPTABLE CHANGE

 ADD	 KEEP	 REMOVE	
			 IDENTITY
			 SIMILARITY
			 DIFFERENCE

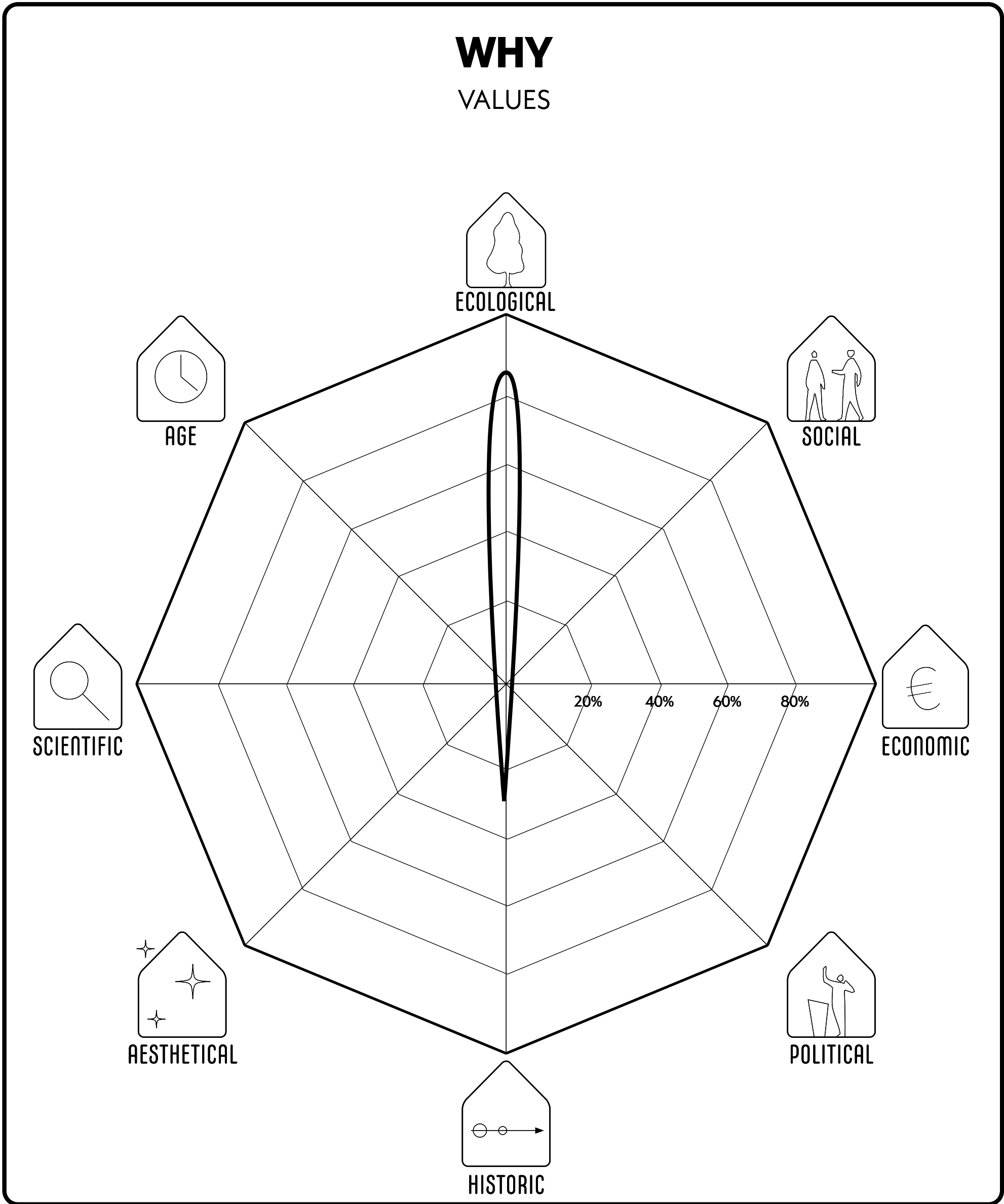

SCENARIO 3.

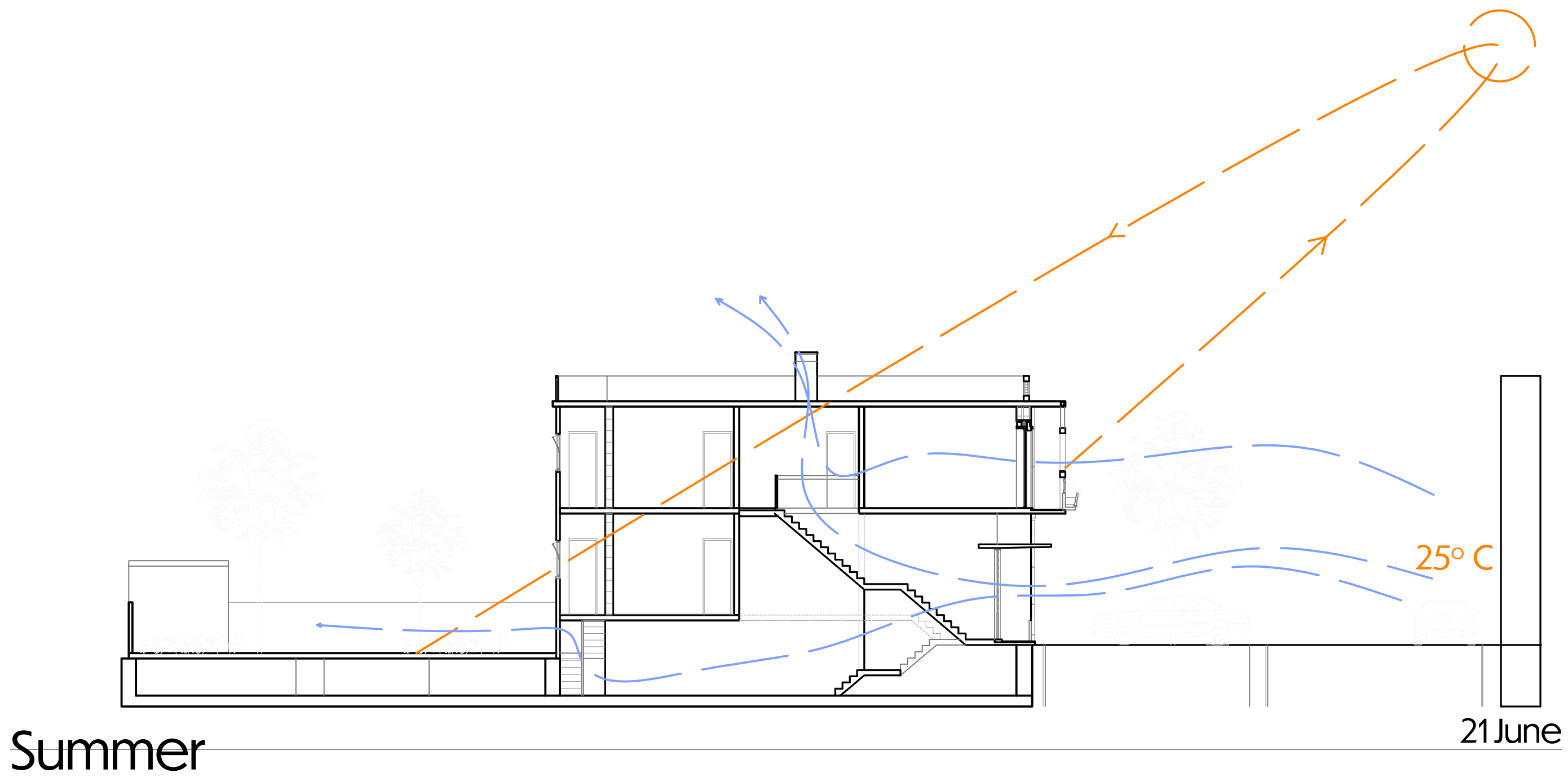
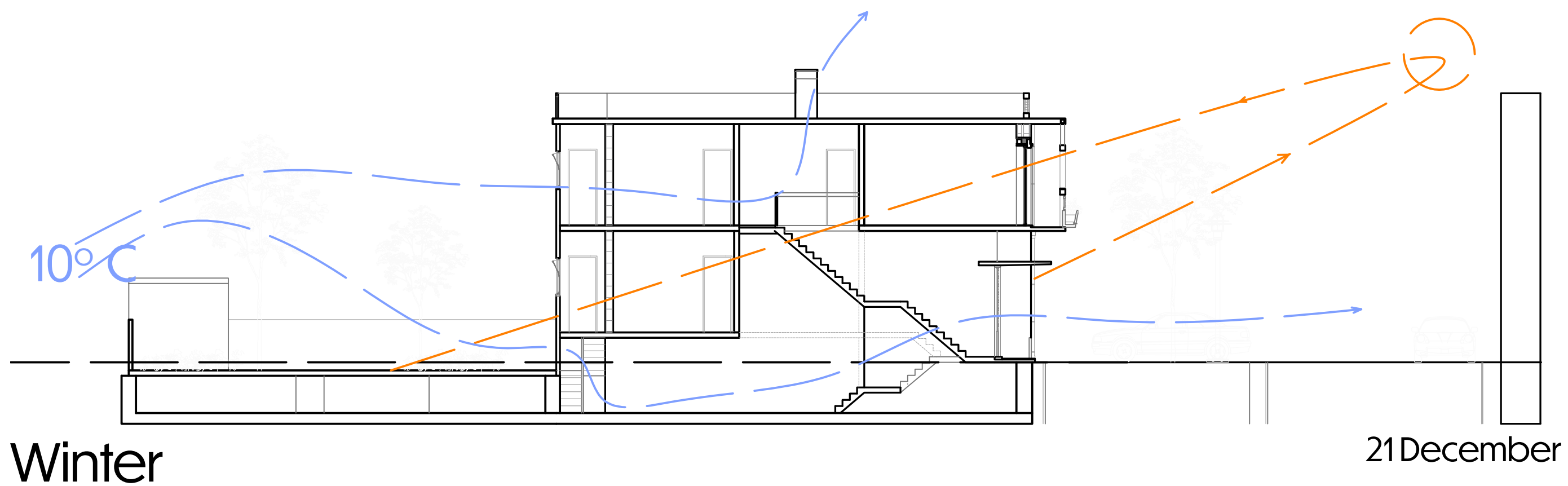

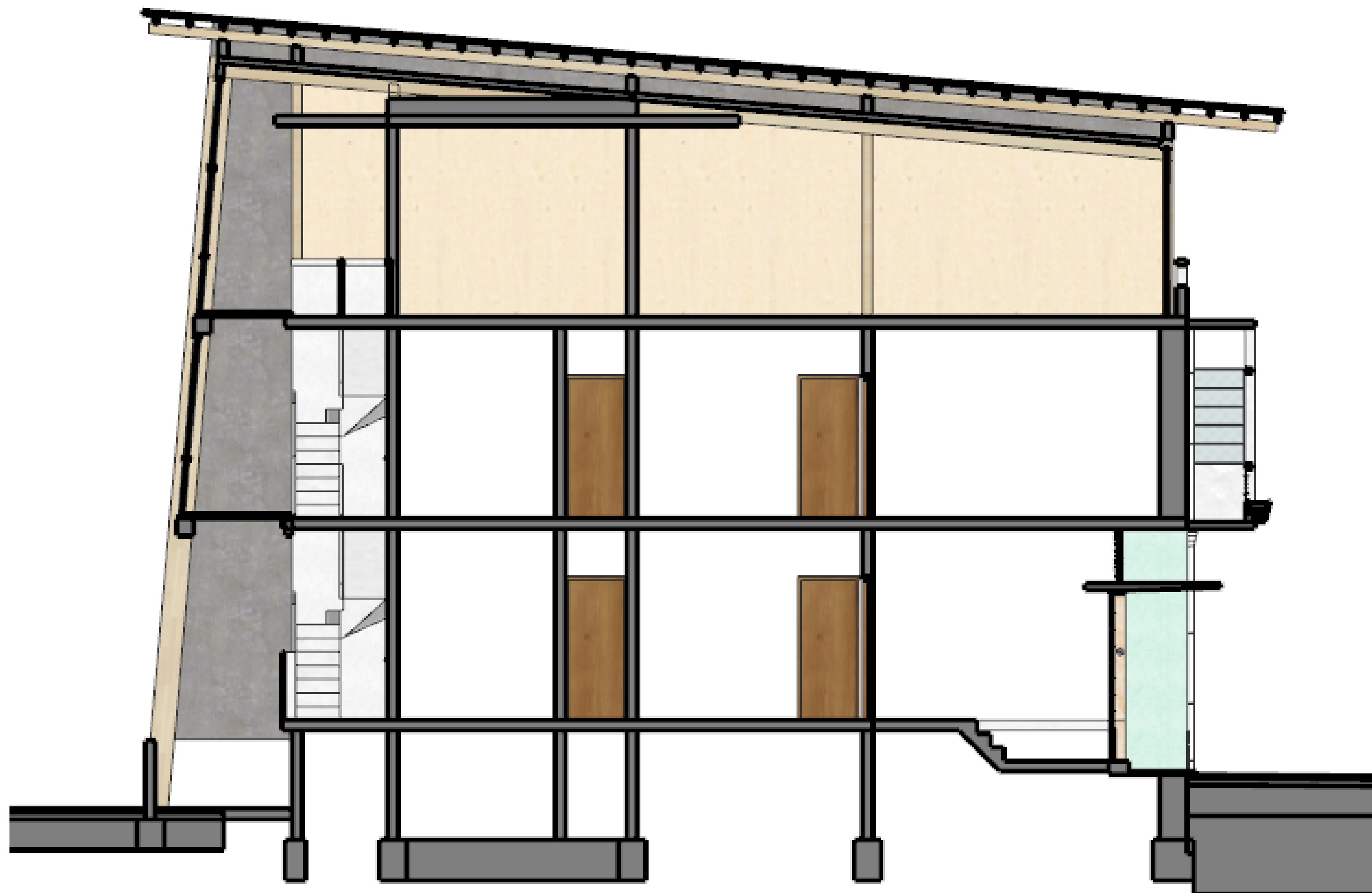



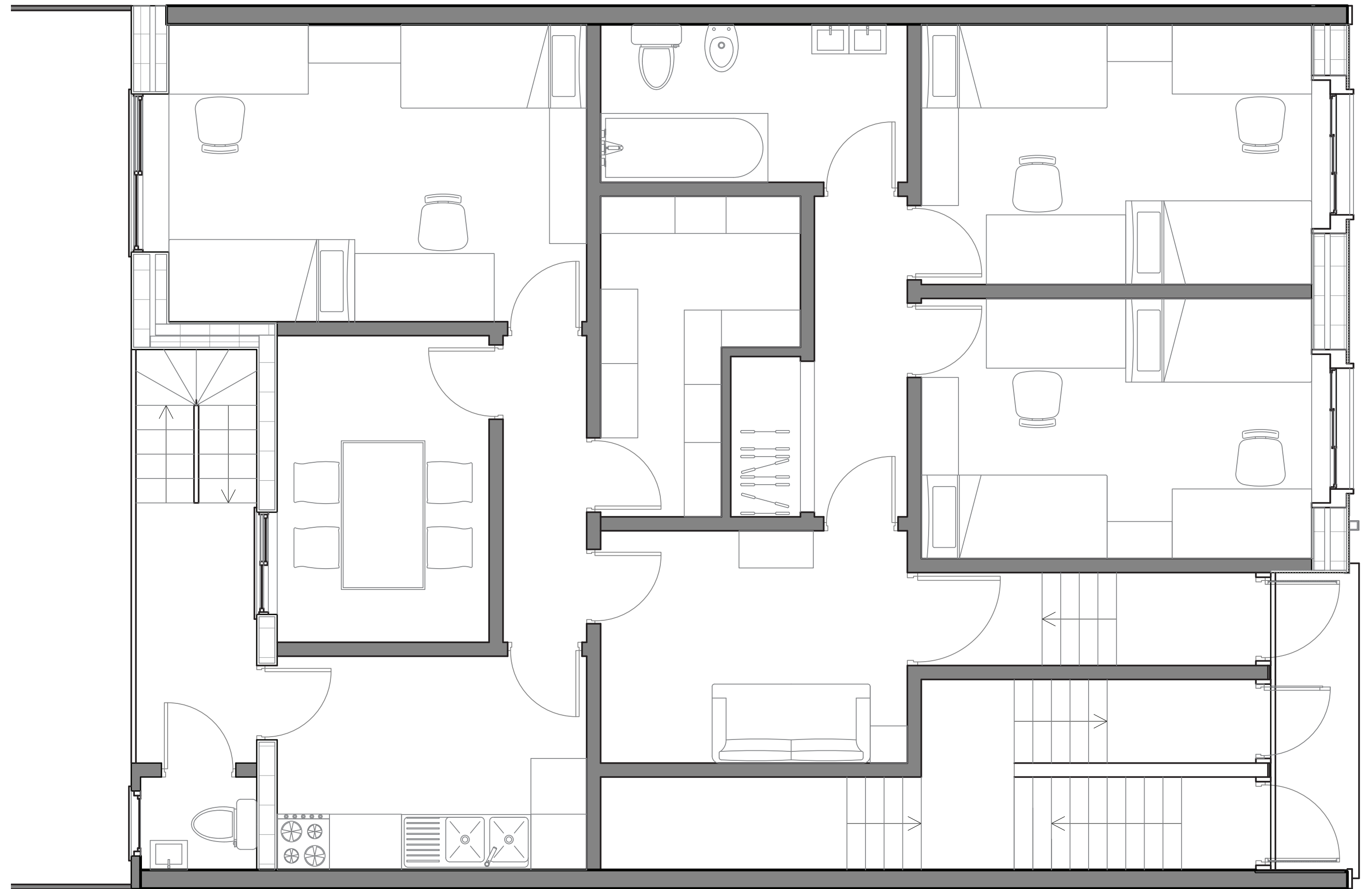

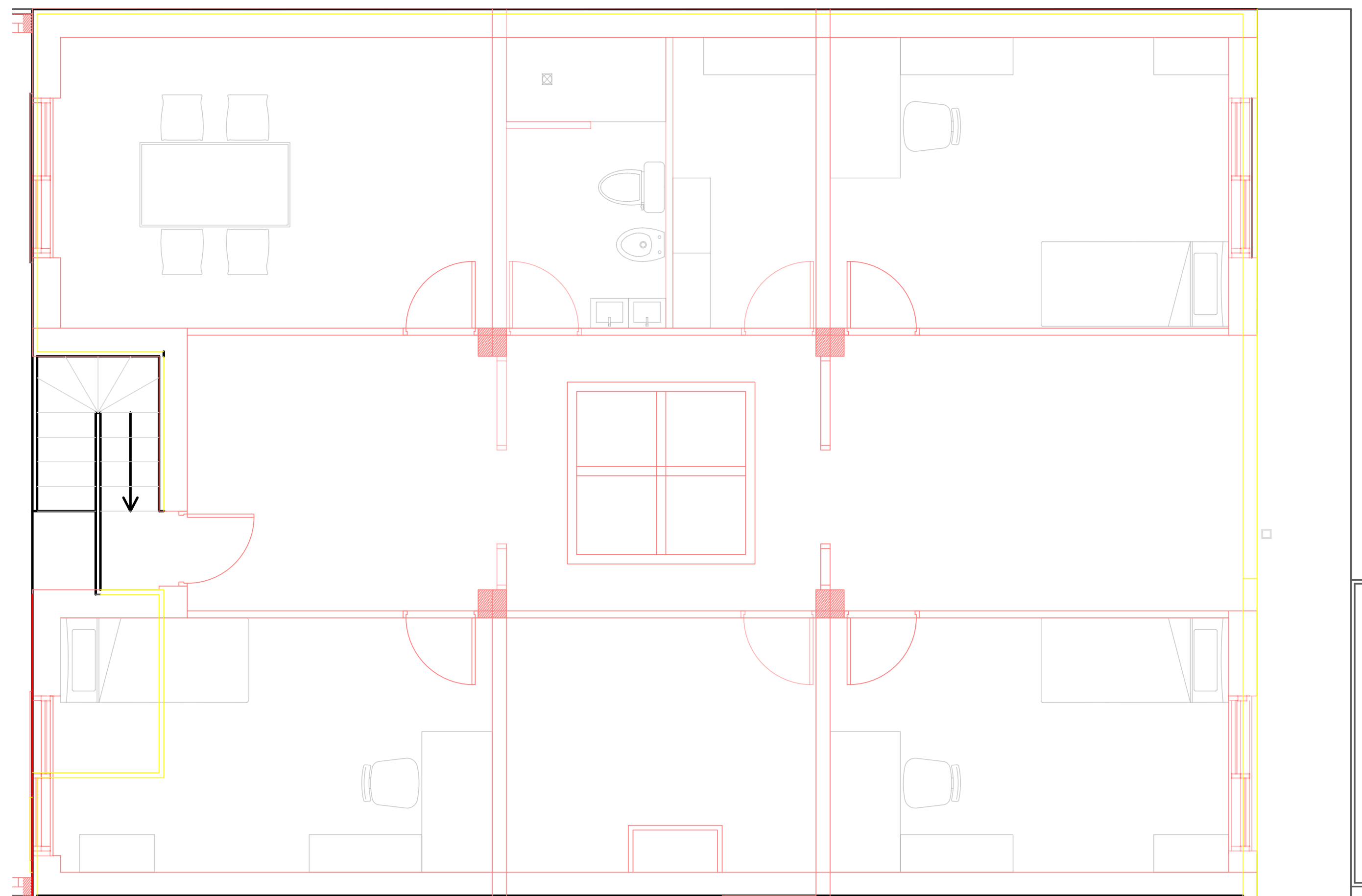

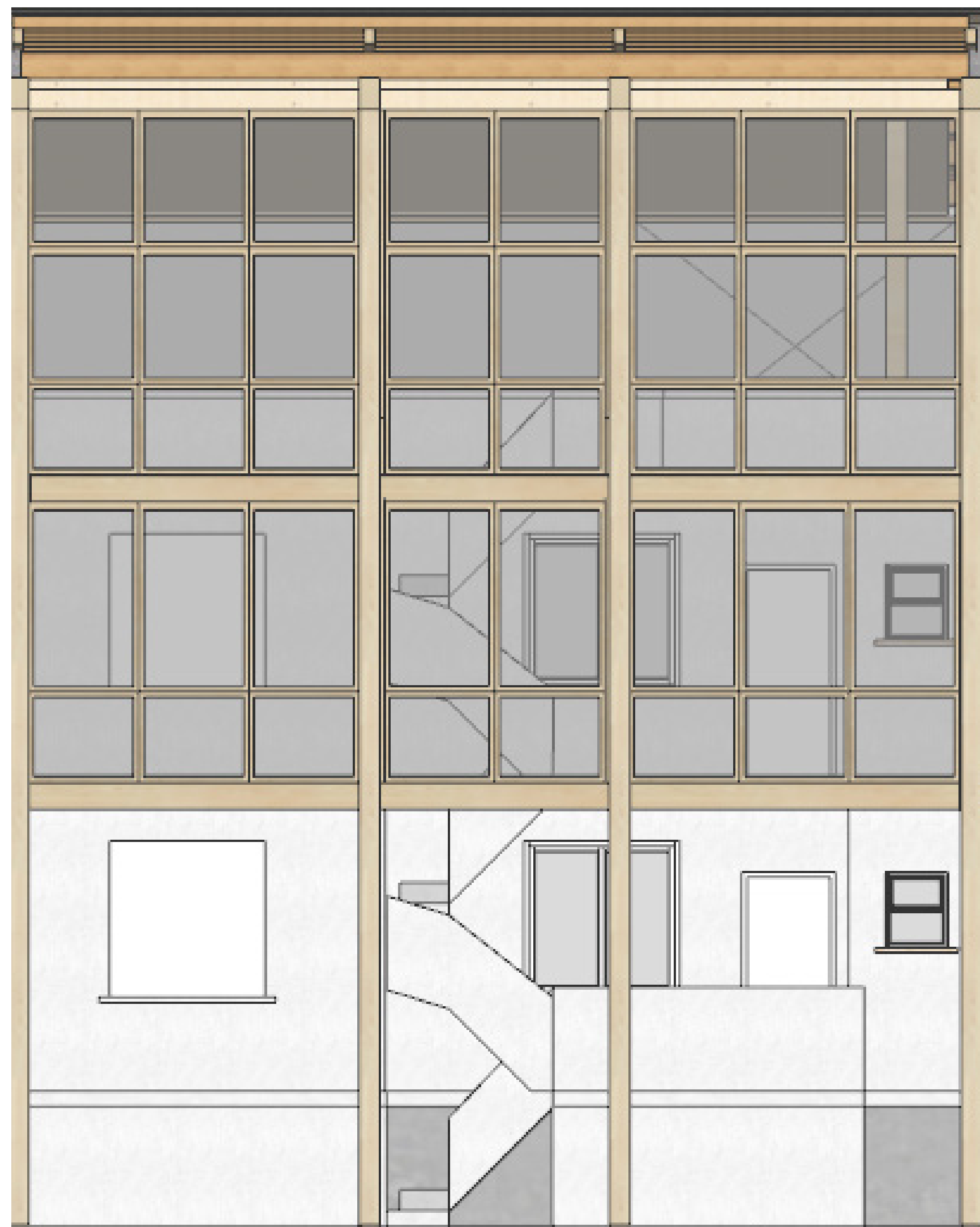



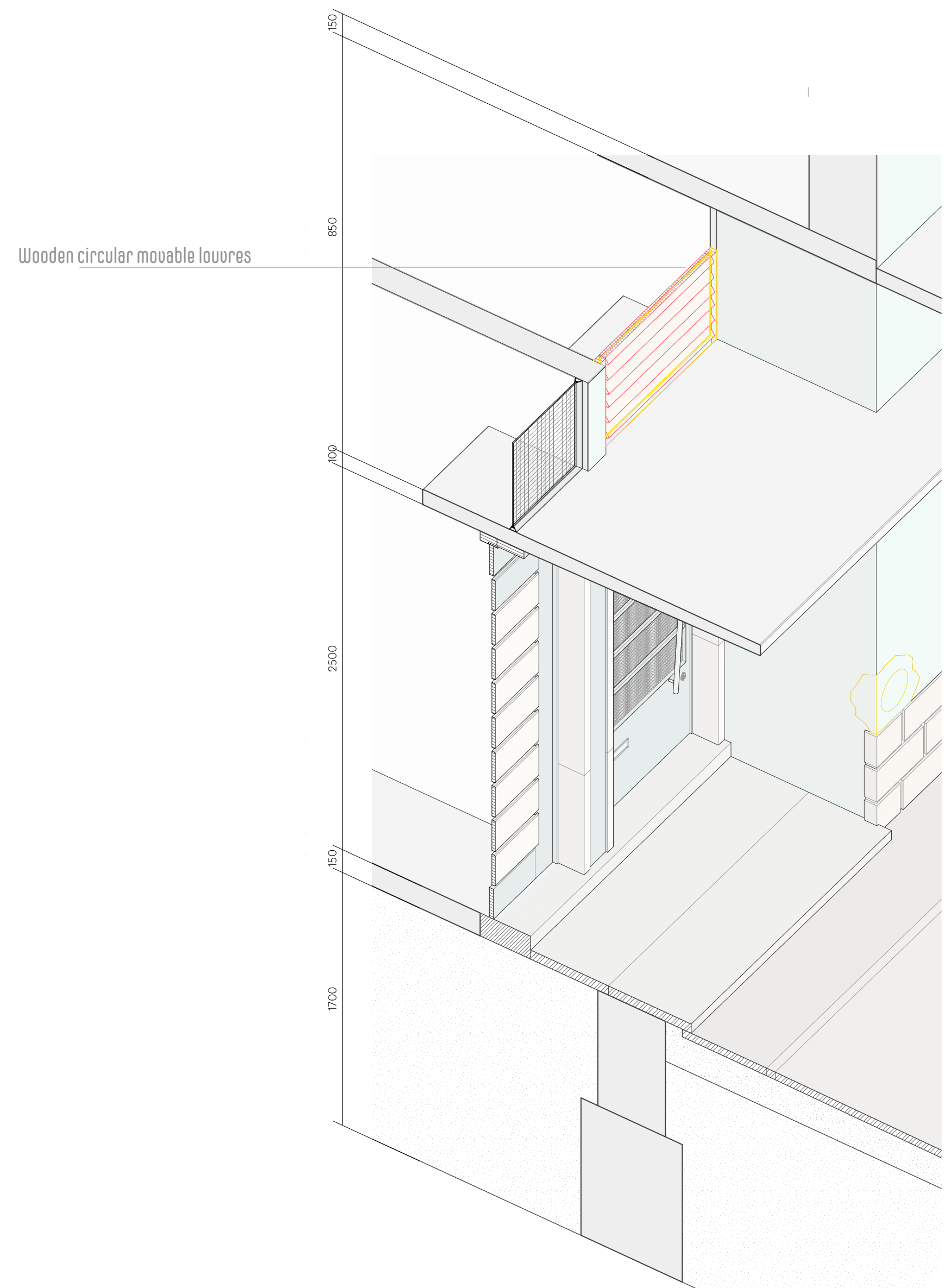

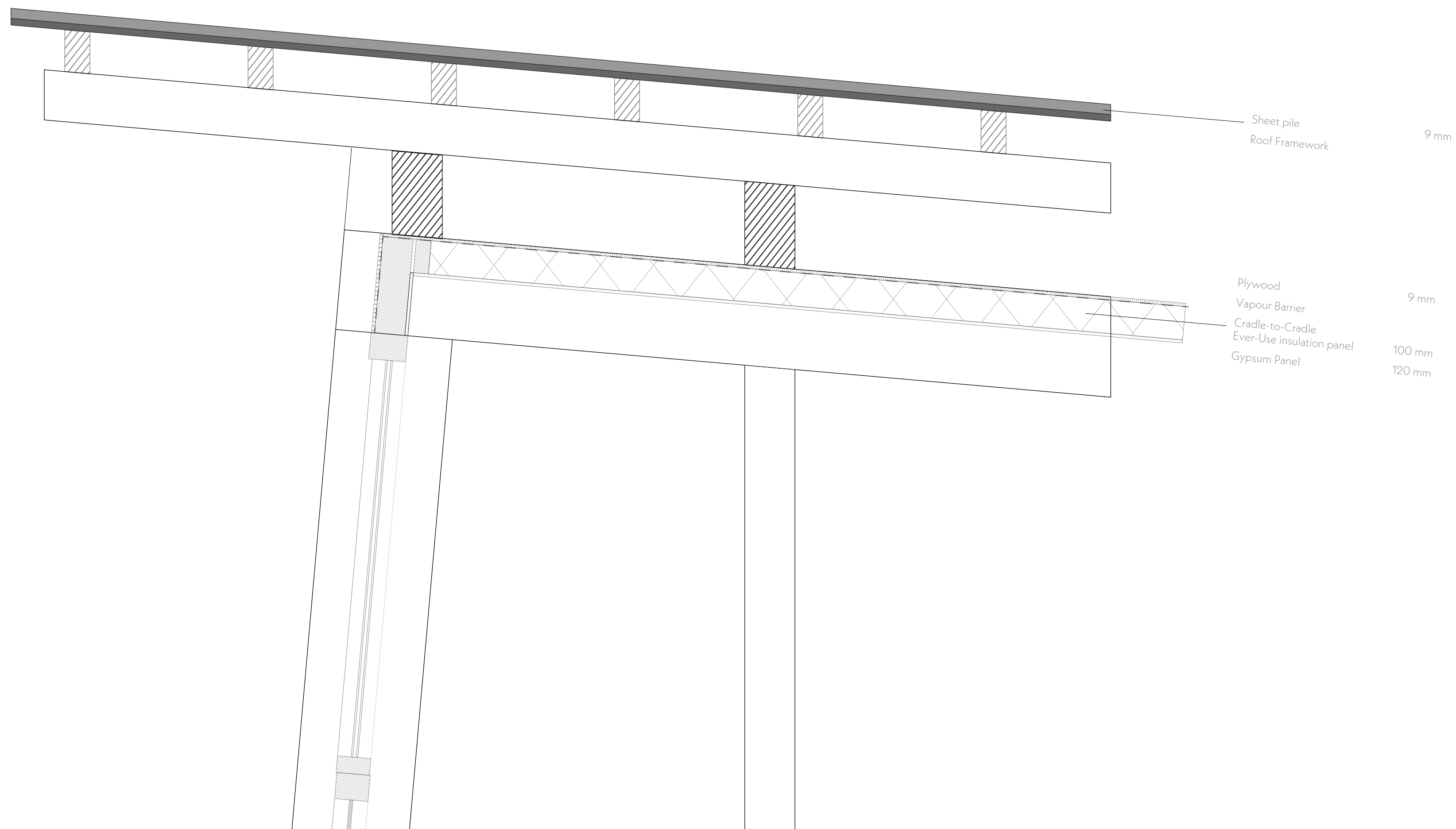



### WHICH LIMITS OF ACCEPTABLE CHANGE



ADD



KEEP



REMOVE

=  
IDENTITY

≈  
SIMILARITY

≠  
DIFFERENCE

### WHY

VALUES

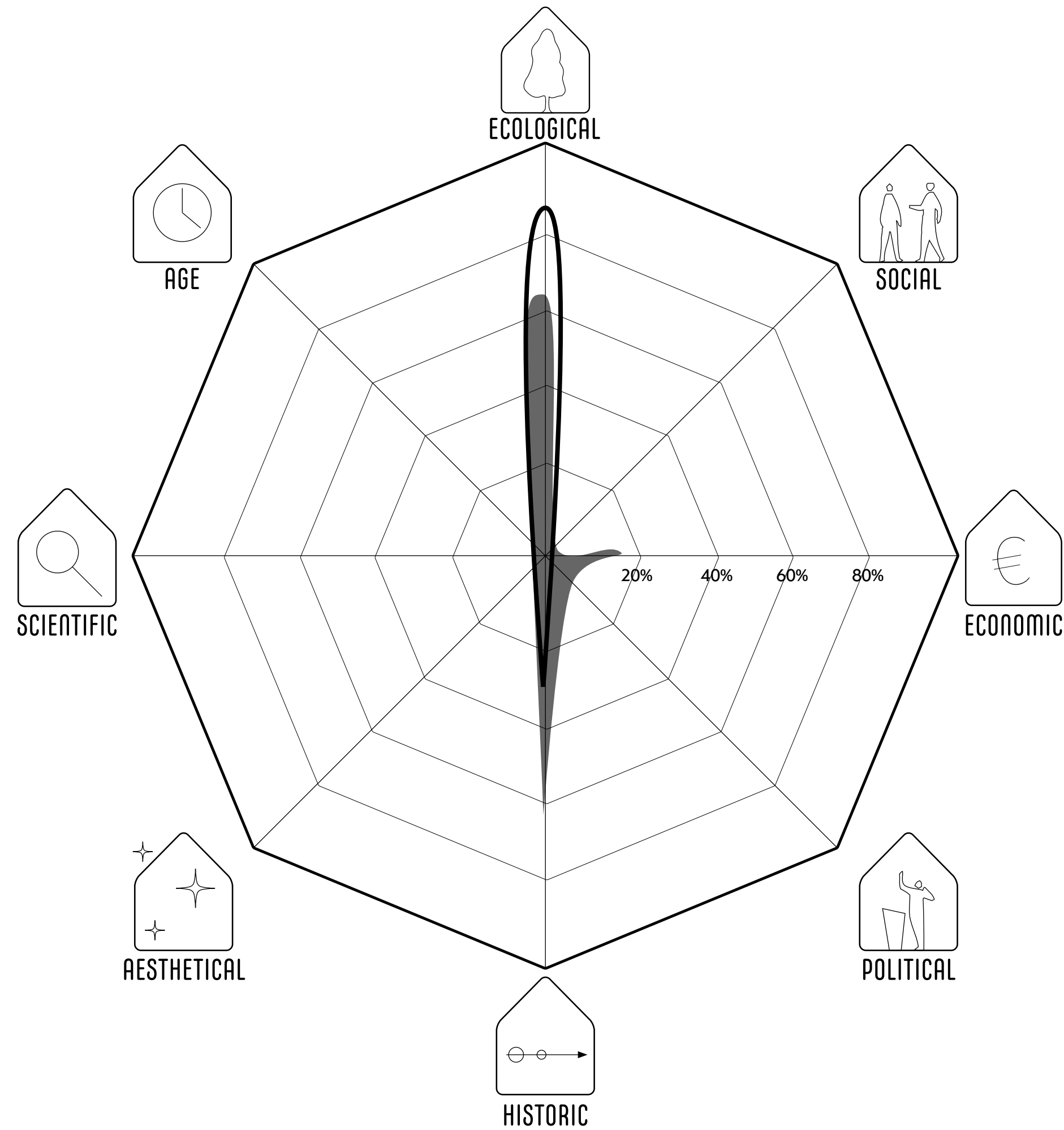

### WHAT

ATTRIBUTES

#### TANGIBLE

STUFF

SPACE PLAN

SERVICES

STRUCTURE

SKIN

SITE

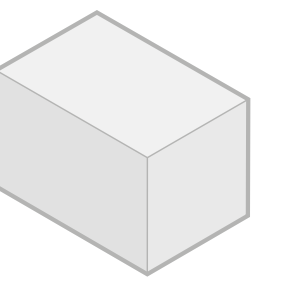
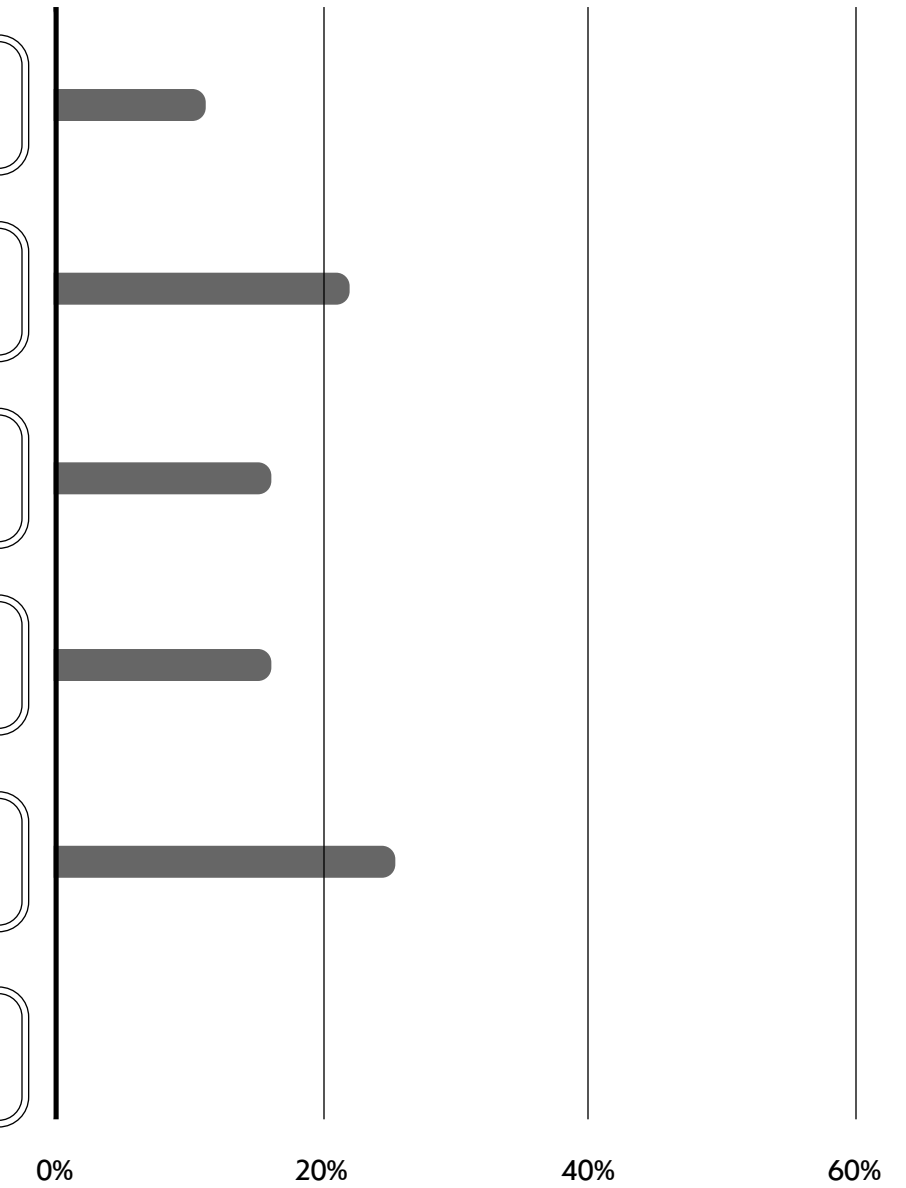

O. CS

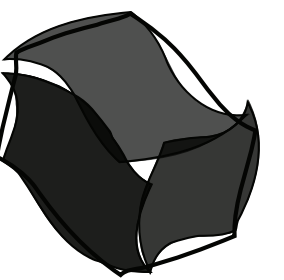

SCENARIO 3.

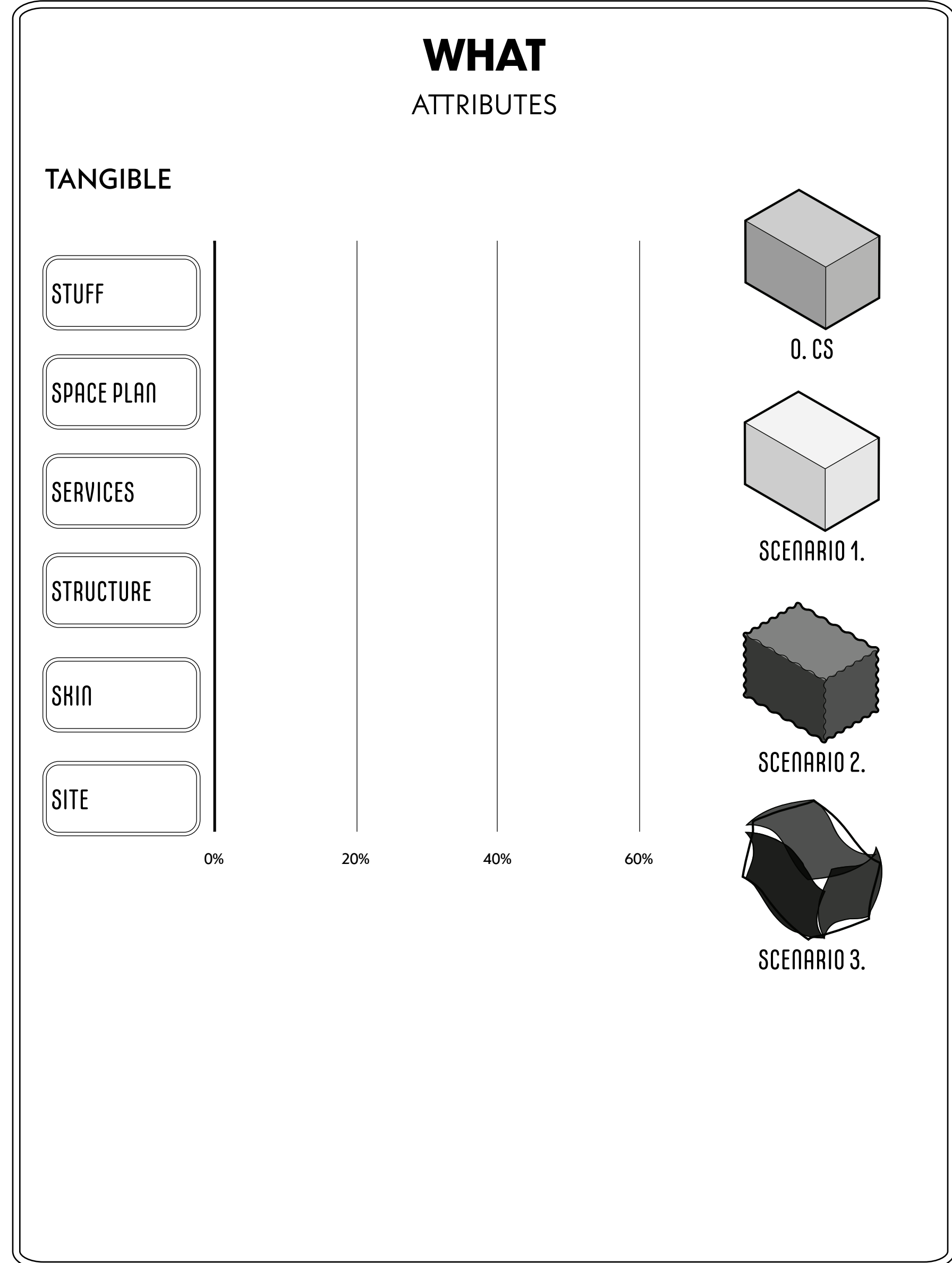
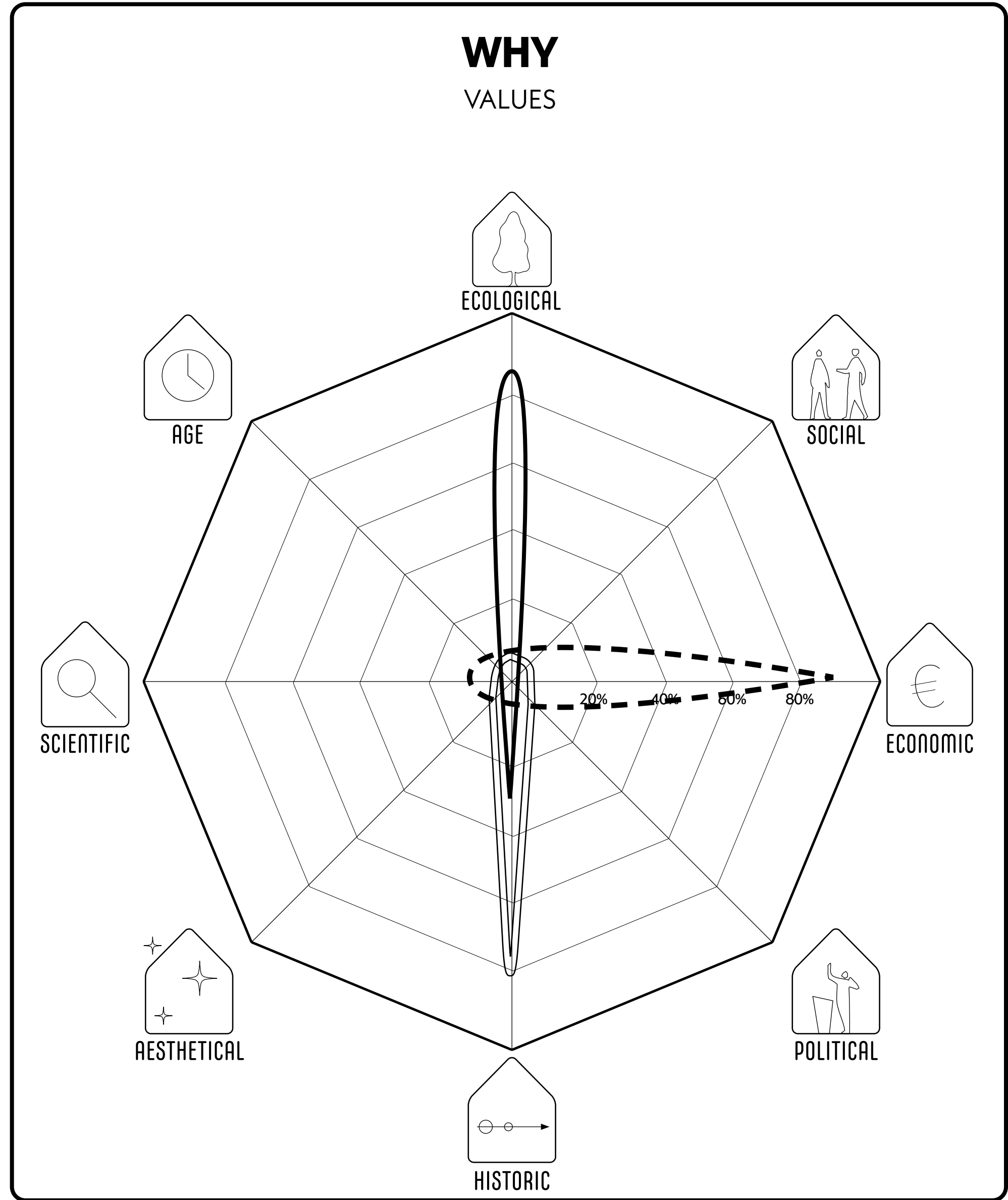
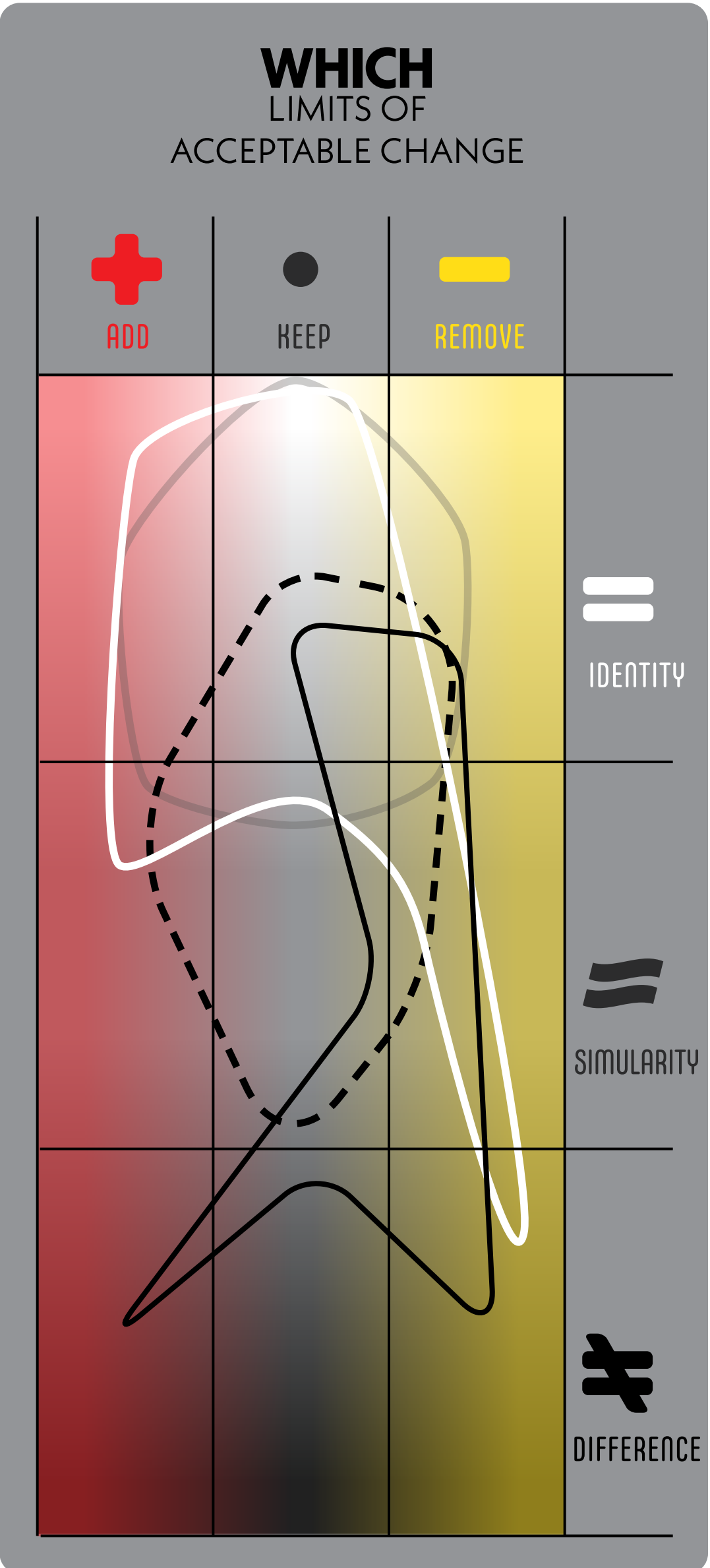



Current Situation

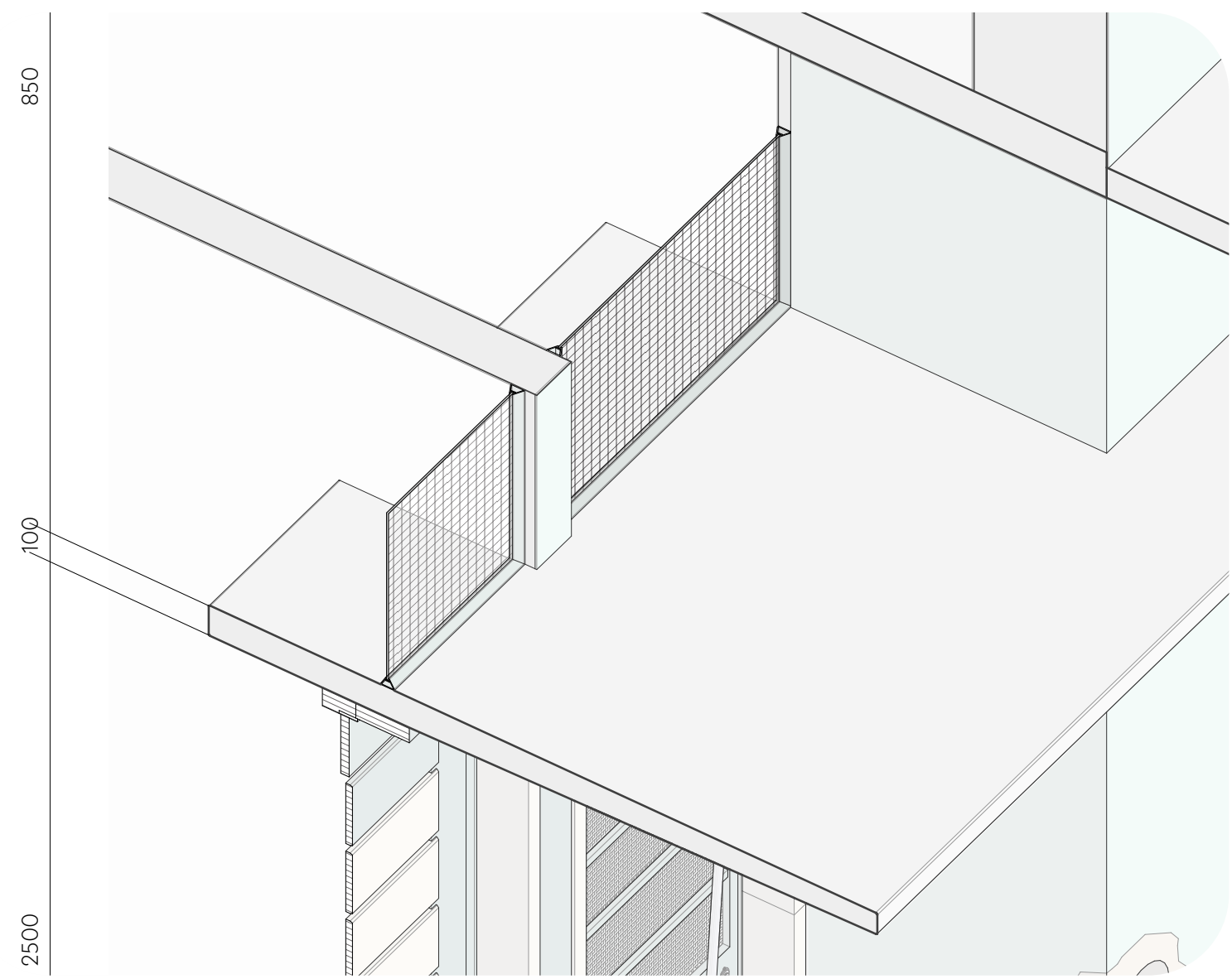

Scenario 2

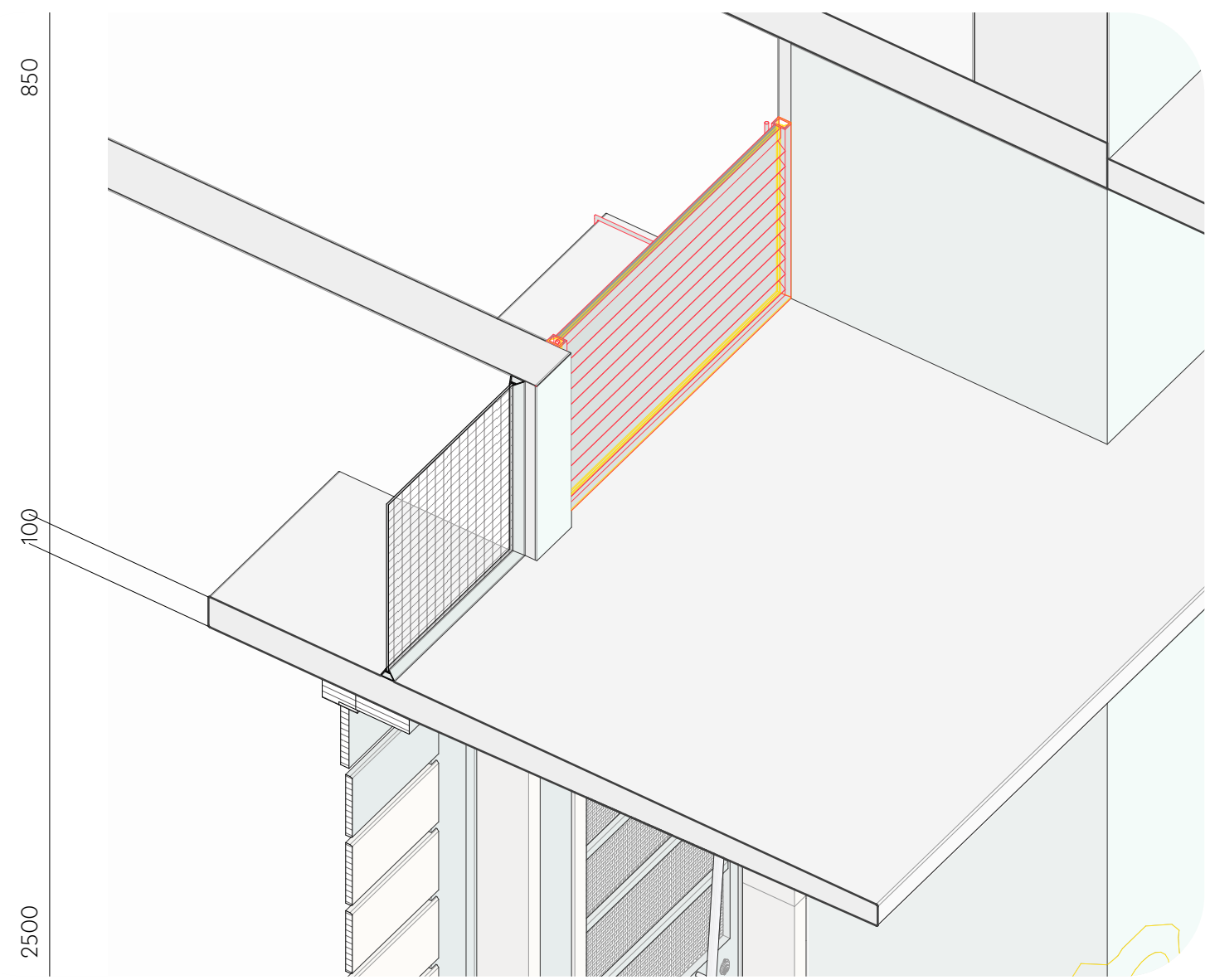

Scenario 1

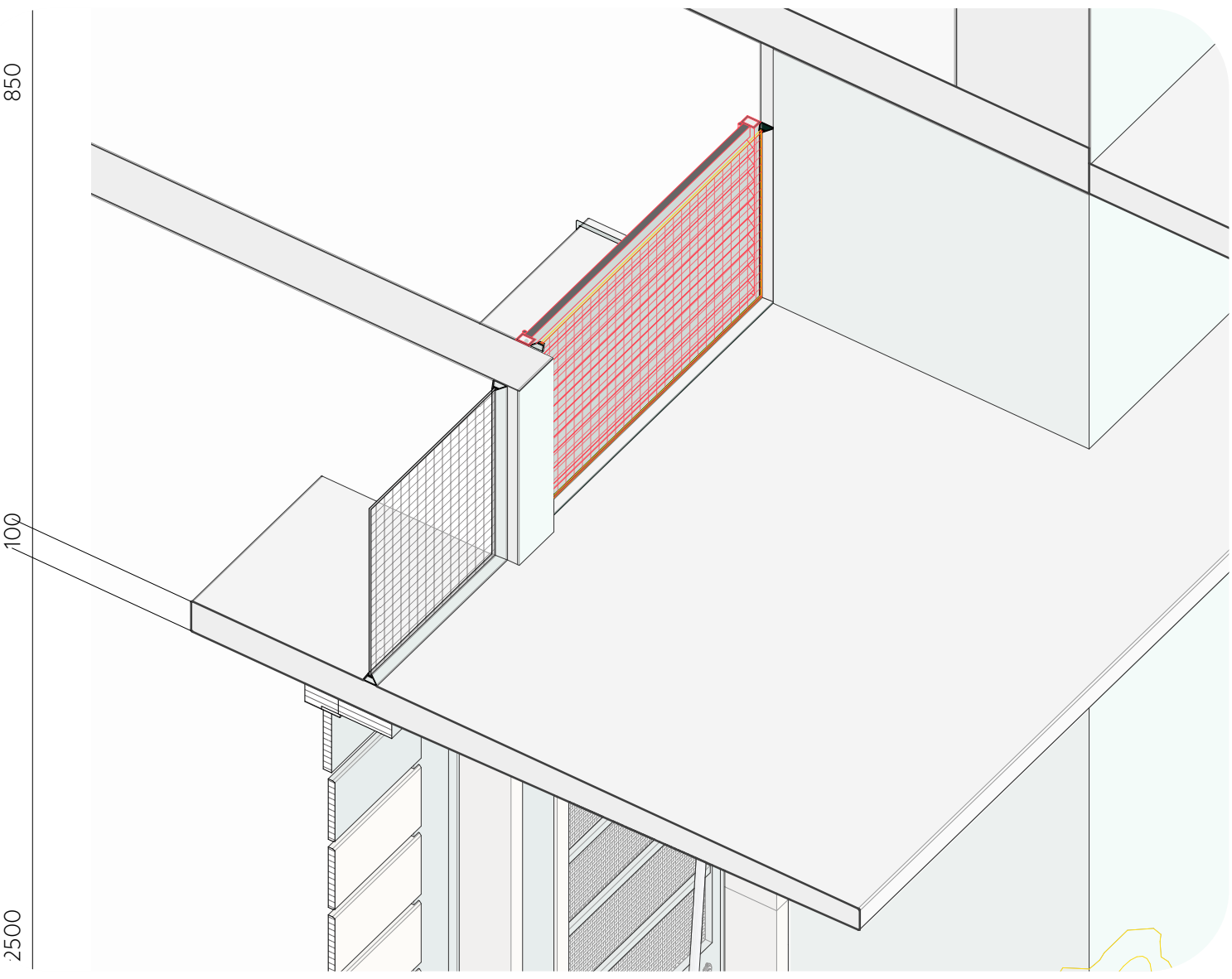

Scenario 3

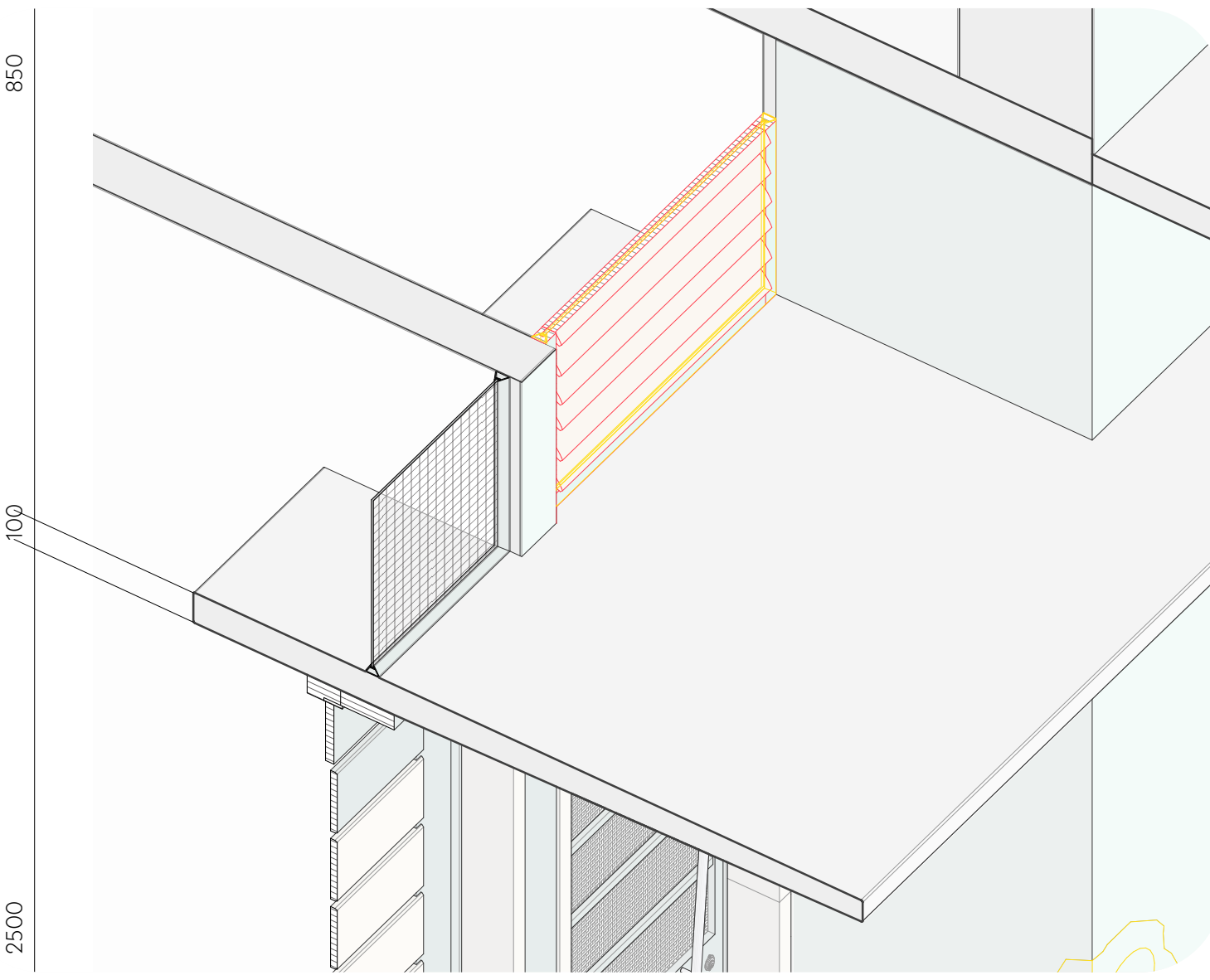



GOAL

PRODUCT

METHODS

METHODOLOGY

# PART 1 INTRODUCTION

# PART 2 RESEARCH

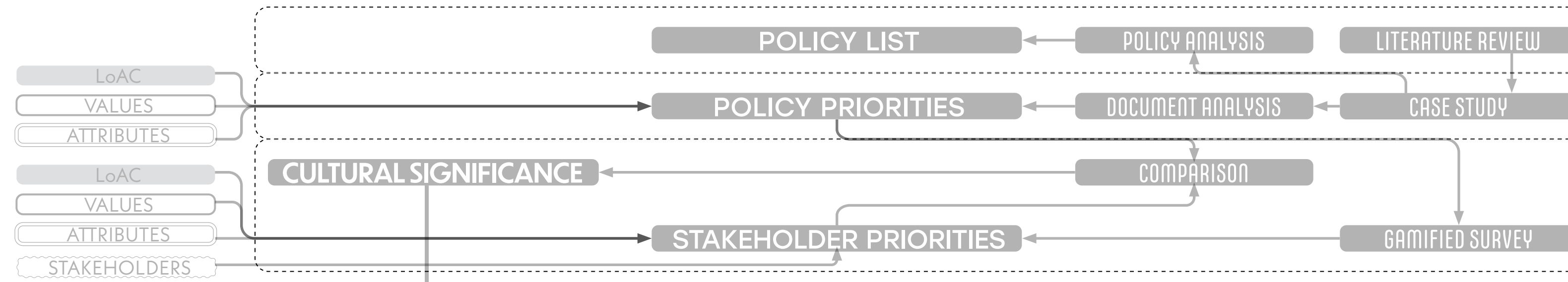

# A CONTEXT

A1 INVENTORY

A2 ANALYSIS

A3 DEFINE SIGNIFICANCE

# PART 3 DESIGN

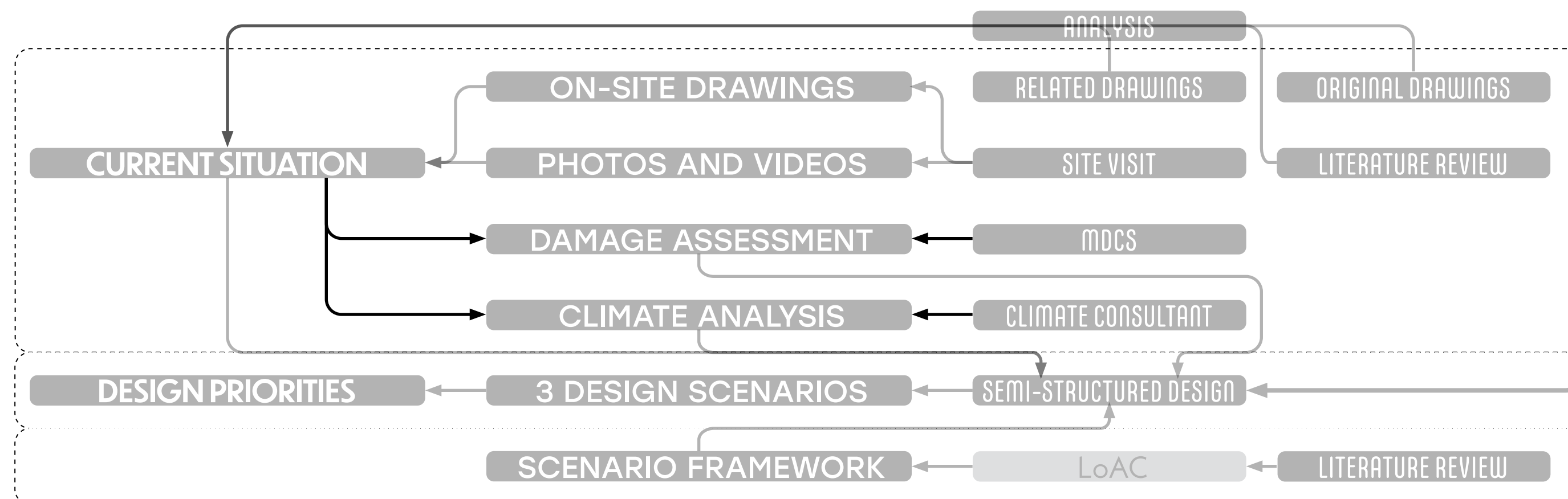

# B STRATEGY

B1 BUILDING ANALYSIS

B2 DEVELOP STRATEGY

B3 INTEGRATE

# PART 4 REFLECTION

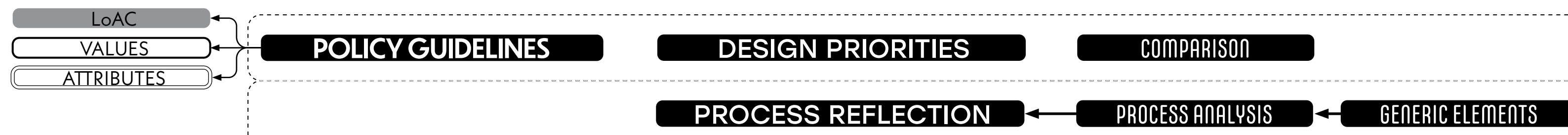

# C MANAGE

C1 PRIORITIZE

C2 PROCESS REFLECTION

GOAL

PRODUCT

METHODS

METHODOLOGY

# PART 1 INTRODUCTION

# PART 2 RESEARCH

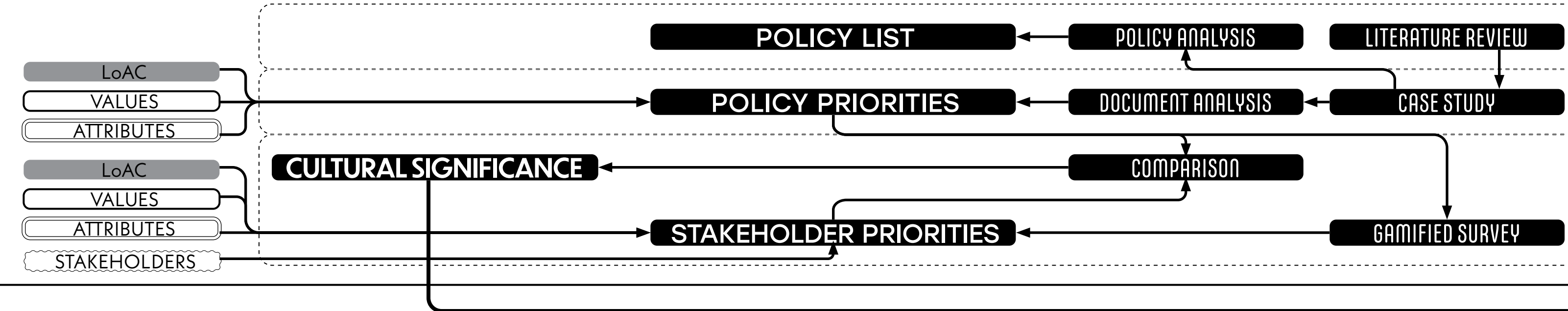

# A CONTEXT

- A1 INVENTORY
- A2 ANALYSIS
- A3 DEFINE SIGNIFICANCE

# PART 3 DESIGN

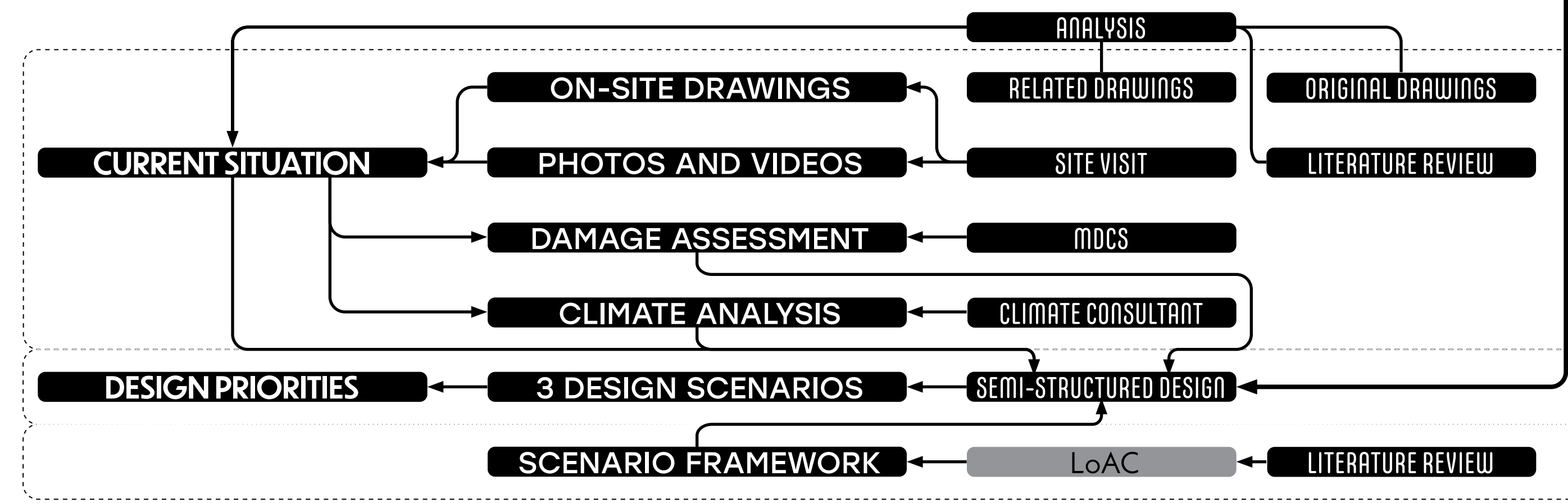

# B STRATEGY

- B1 BUILDING ANALYSIS
- B2 DEVELOP STRATEGY
- B3 INTEGRATE

# PART 4 REFLECTION

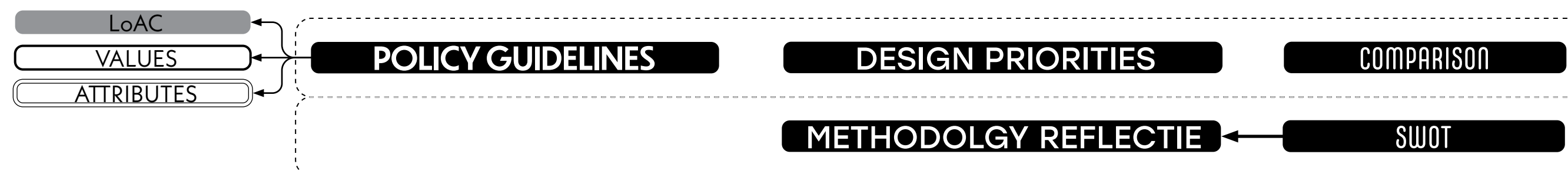

# C MANAGE

- C1 PRIORITIZE
- C2 PROCESS REFLECTION



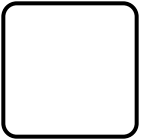

<p><u>Strengths</u></p>	<p><u>Weaknesses</u></p>
<p><u>Opportunities</u></p>	<p><u>Threats</u></p>