

Alleviating urban loneliness

Devising a template for the not-lonely neighbourhood



DESIGN AS POLITICS PRESENTS
A CITY OF COMINGS AND GOINGS
DESIGNING FOR MIGRATION AND MOBILITY
GRADUATION STUDIO 2017/2018



“How can we design buildings, cities and landscapes that make the best of our restless, migratory, lives?”

**DESIGN
AS
POLITICS**



School in Norfolk, England
Alison & Peter Smithson, 1949-1954



School in Hertfordshire, England,
Stirratt Johnson-Marshall and the Ministry of
Education, circa 1950



Sculpture

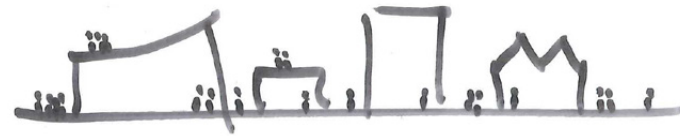

Architecture

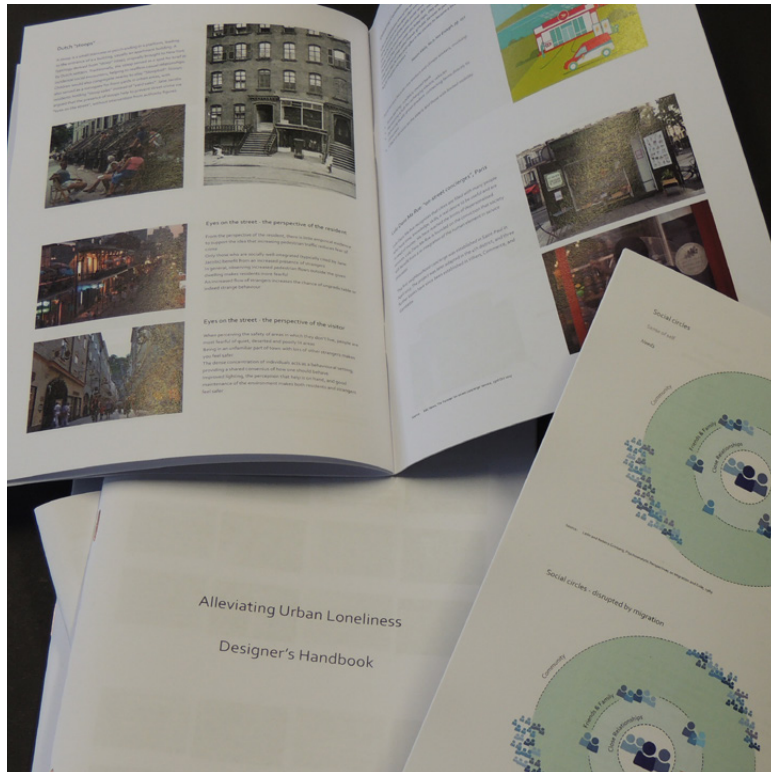

Problem Statement

Hunger

Avoid malnutrition.

Pain

Avoid further tissue damage.

Thirst

Avoid dehydration.

Loneliness

Avoid social exclusion.

Hunger

Eat food.

Pain

Protect and heal the painful area.

Thirst

Drink water.

Loneliness

A very complex balance of objective and subjective alterations.

Probability of decreased mortality relating to various health conditions

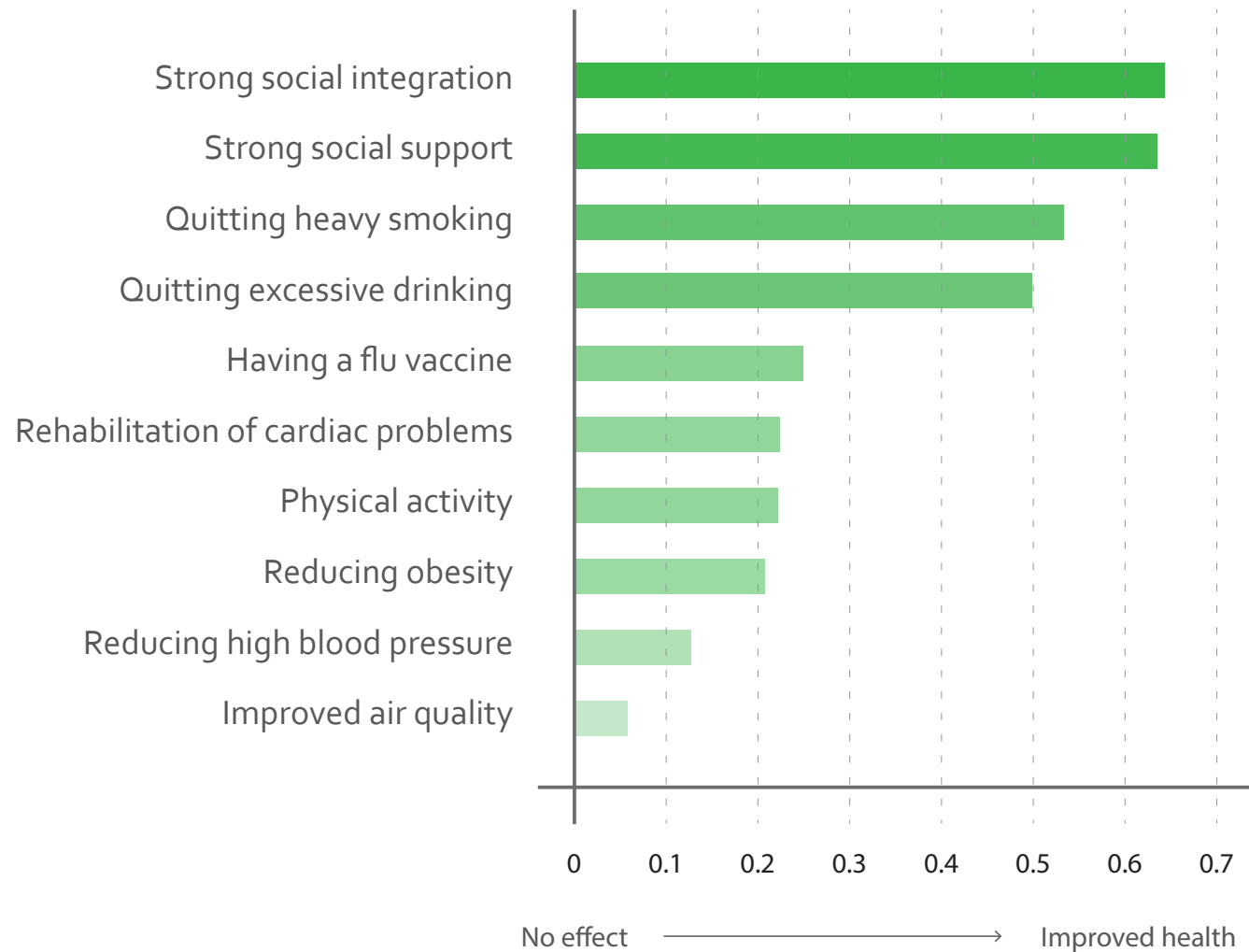

Source: Holt-Lunstad, Julianne, Timothy B. Smith, and J. Bradley Layton, 'Social Relationships and Mortality Risk: A Meta-Analytic Review', PLoS Med, 7 (2010)

Social-emotional pain as comparable to physical pain

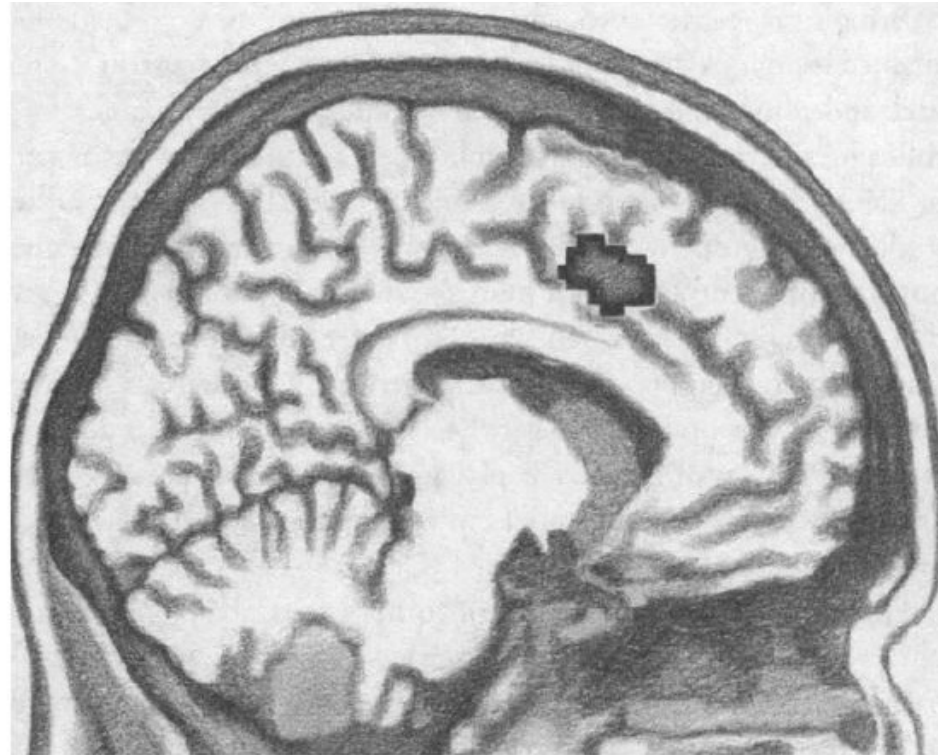

FIGURE 2. The human brain reacting to social pain. The dark rectangular blotch near the top of the brain represents the activation of the dorsal anterior cingulate cortex in response to social rejection. The brain responds similarly to physical pain. Adapted from N. I. Eisenberger, M. Lieberman, and K. D. Williams, "Does rejection hurt? An fMRI study of social exclusion," *Science* 302 (10 October 2003): 290-292.

Three components of well-being

Physical

Mental

Social

"Health is a state of complete physical, mental, and social well-being and not merely the absence of disease or infirmity."

*The Constitution of the World Health
Organization
1948*

Three components of well-being

Physical

Global cost of obesity-related illness to hit \$1.2tn a year from 2025

Health bill will be 'enormous burden' without more preventative measures to check worsening epidemic, say experts



In 2014, 34% of men and women in the US were obese; by 2025 that is predicted to be 41%. In the UK, 27% were obese in 2014, a figure set to rise to 34% by 2025. Photograph: Alamy Stock Photo

Mental

'Depression lost me my job': How mental health costs up to 300,000 jobs a year

By Katie Silver
Health reporter, BBC News

26 October 2017 | Health | 422

f t m e Share

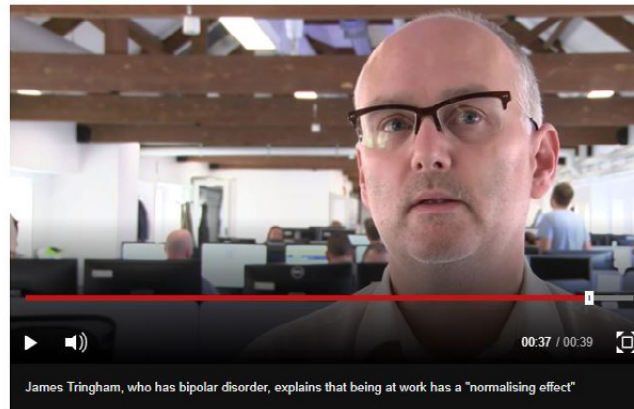

Social

Loneliness twice as unhealthy as obesity for older people, study finds

Scientists found that the loneliest were nearly twice as likely to die during their six-year study than the least lonely



The findings point to a pending crisis in the UK as the population ages and people increasingly live alone or far from their families. Photograph: Paul Doyle/Alamy

Urgency of thesis

Core component of our *evolutionary biology*

Core component of our *well-being*

Further Research

Loneliness and Migration

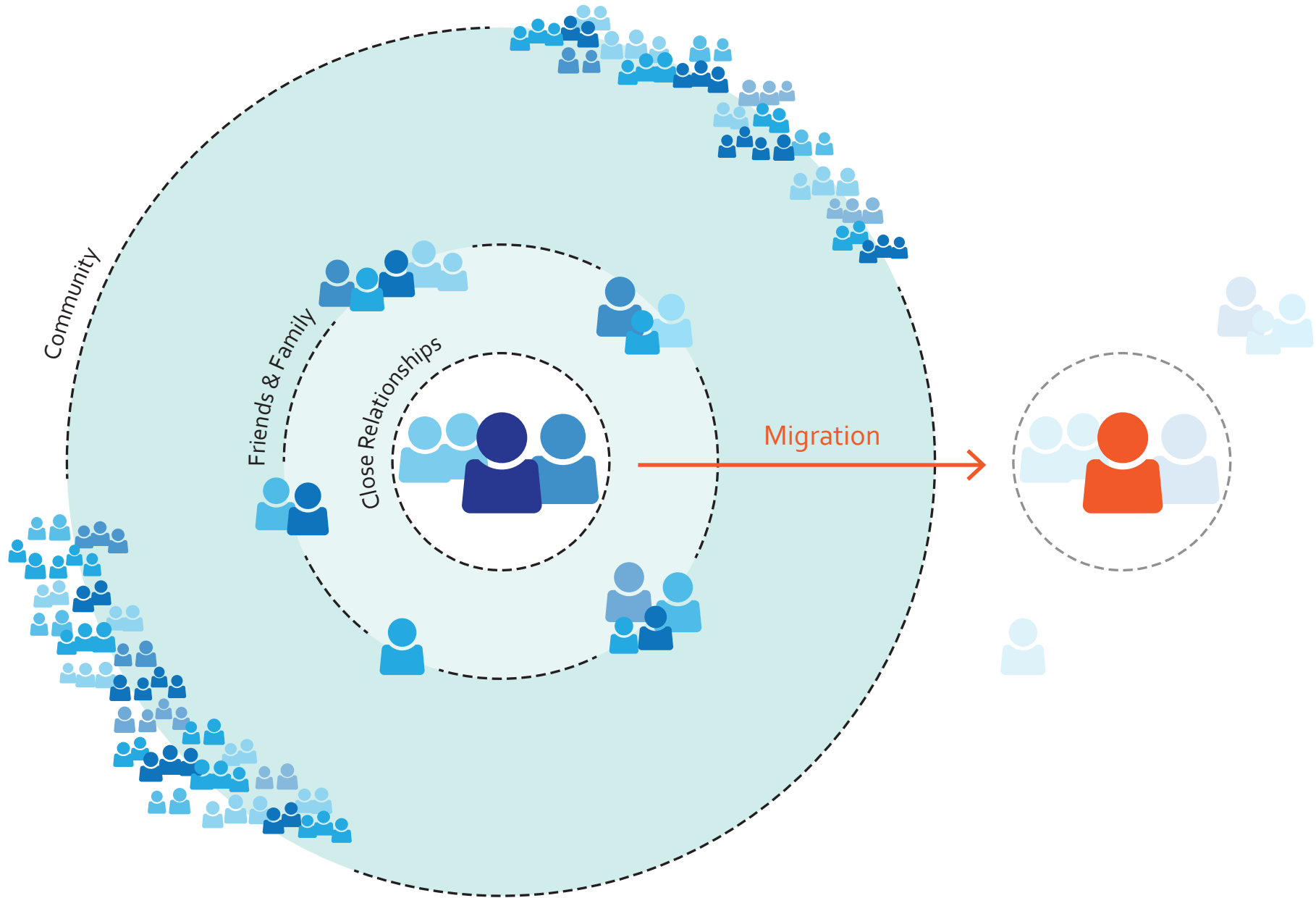

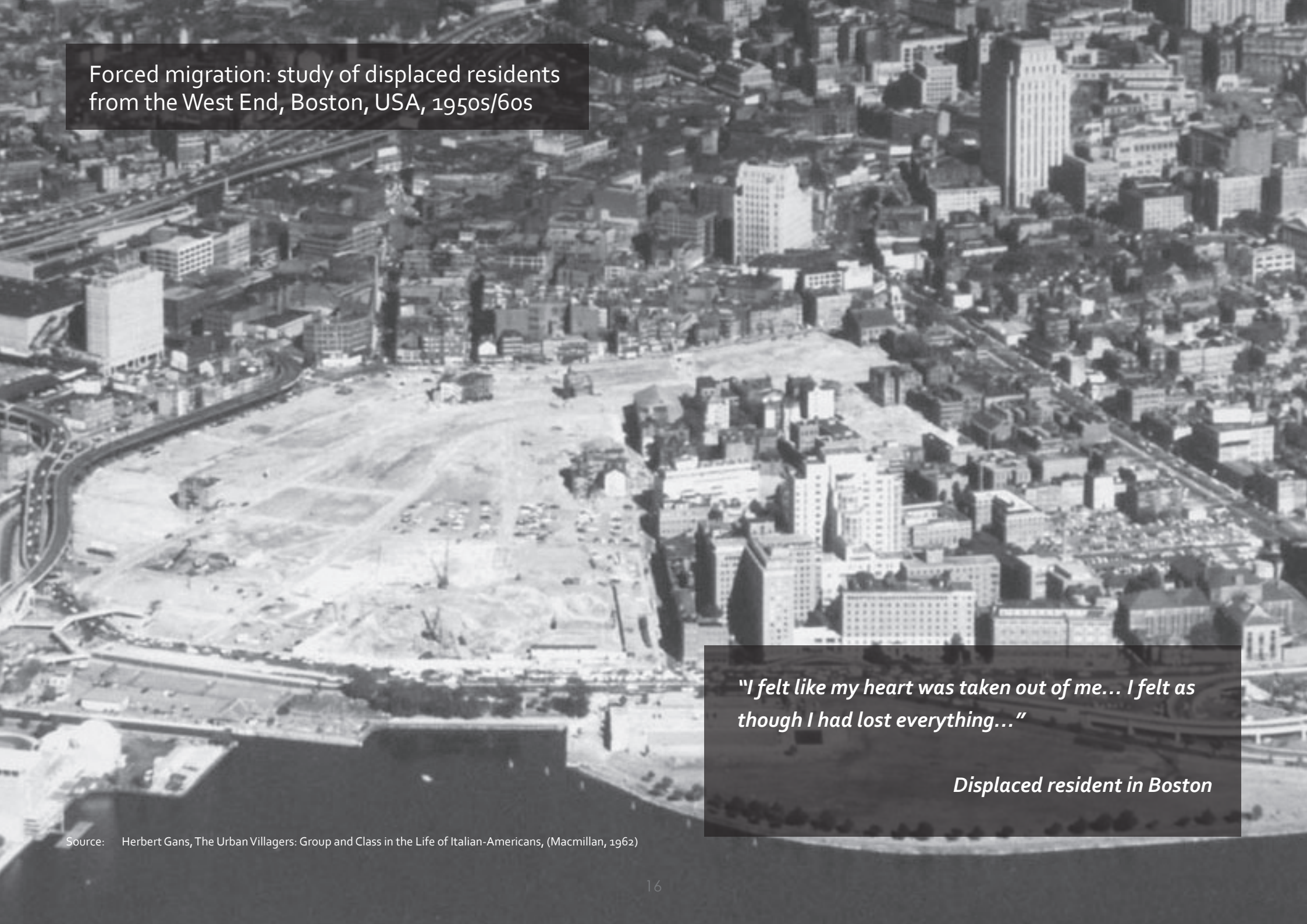
An aerial black and white photograph of a city, likely Boston, showing a large, cleared area in the foreground, possibly a site of urban renewal or displacement. The surrounding city is dense with buildings and streets.

Forced migration: study of displaced residents
from the West End, Boston, USA, 1950s/60s

*"I felt like my heart was taken out of me... I felt as
though I had lost everything..."*

Displaced resident in Boston

Source: Herbert Gans, *The Urban Villagers: Group and Class in the Life of Italian-Americans*, (Macmillan, 1962)

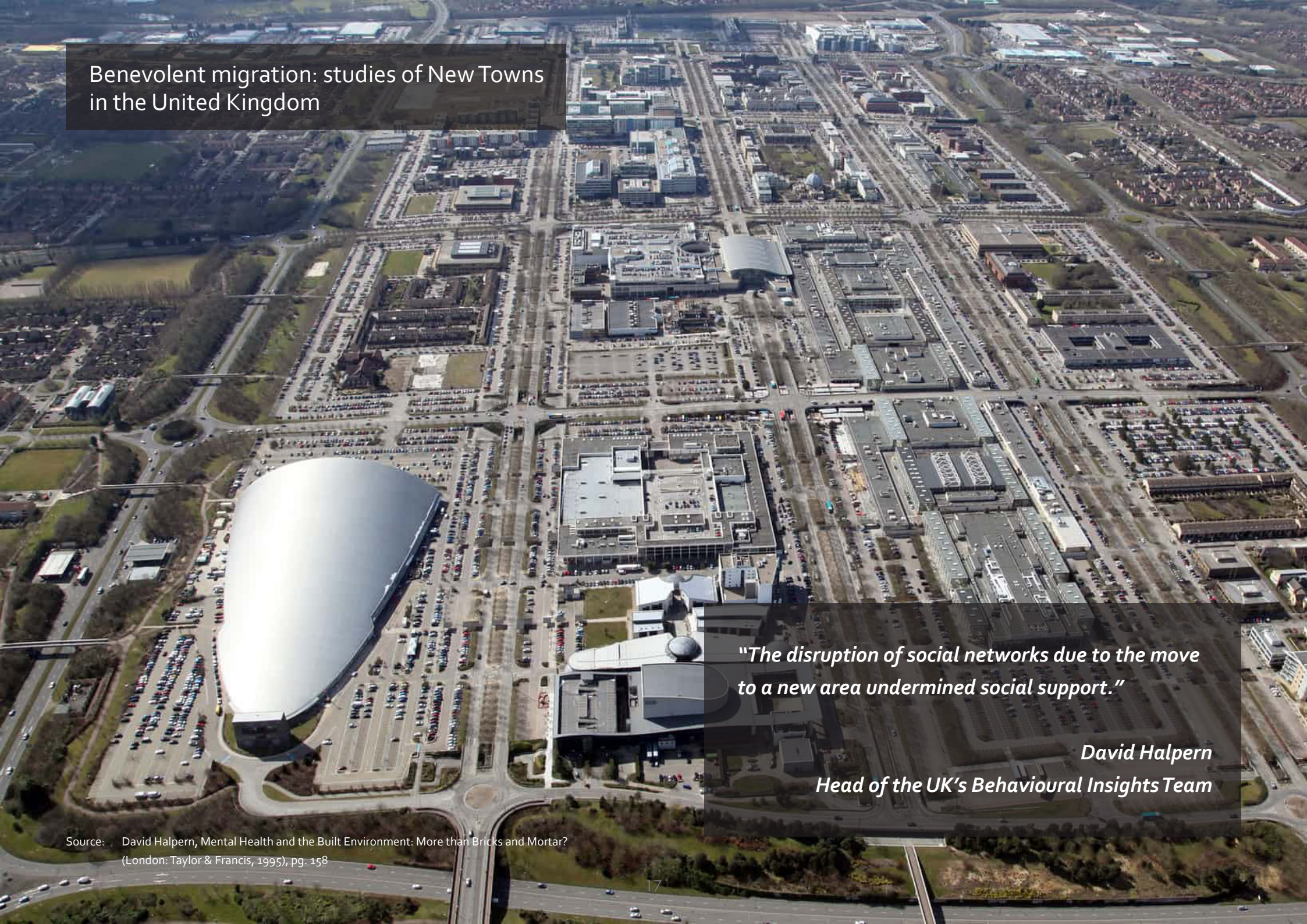

Benevolent migration: studies of New Towns
in the United Kingdom

*"The disruption of social networks due to the move
to a new area undermined social support."*

*David Halpern
Head of the UK's Behavioural Insights Team*

Source: David Halpern, *Mental Health and the Built Environment: More than Bricks and Mortar?*
(London: Taylor & Francis, 1995), pg. 158

The Dispersed City

Physical



Siedlung, Frankfurt
c. 1930

Mental



DAF car advertisement
c. 1955

Social



Gellerup, Aarhus
c. 1970

The Densified City

Physical

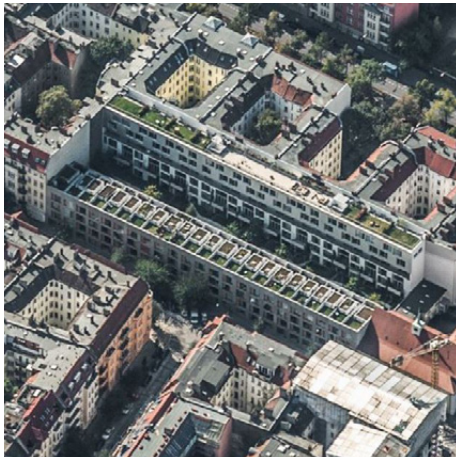

BIGyard, Berlin
2010

Mental

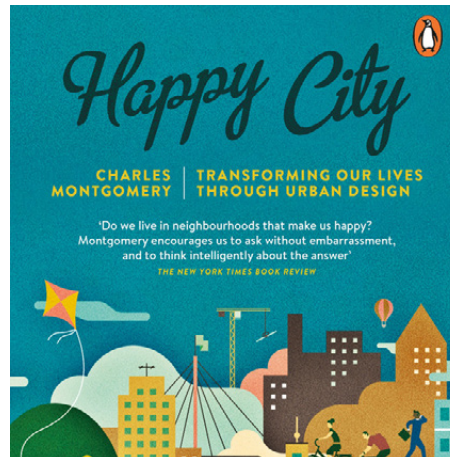

Happy City
2013

Social



Inner City Vision
Eindhoven 2016

Solution?



*The Collective Old Oak, Willesden Junction, London
PLP Architects
Working for The Collective Partners LLP*



*Proposal for The Collective, Stratford London
PLP Architects
Working for The Collective Partners LLP*

Debunking the myths of loneliness

“Take lonely people and put them in a room together”

Physical - solitude



Social - loneliness



Social engagement: *Living alone vs. feeling alone* - comparing the EU 28

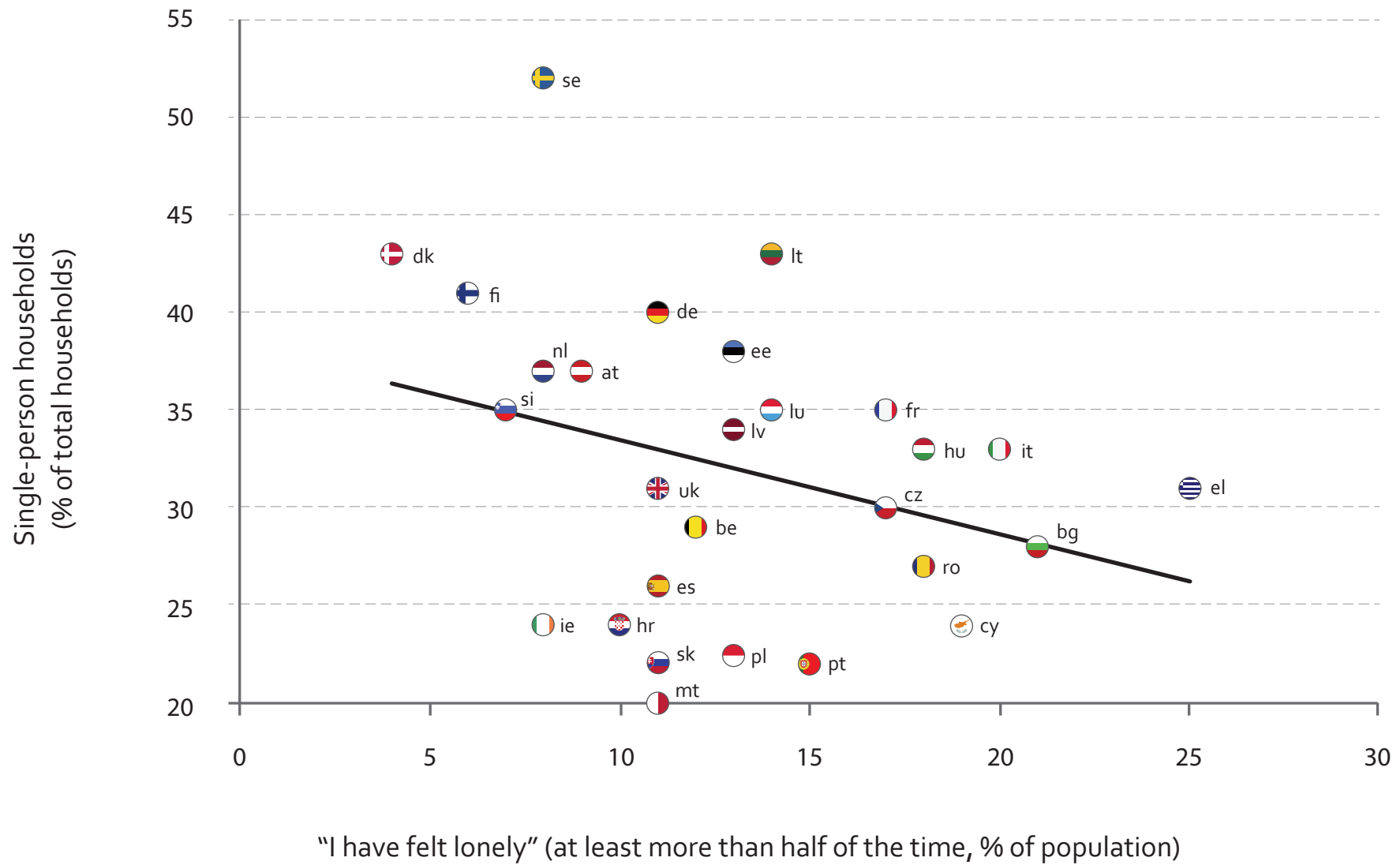

Sources: European Quality of Life Survey 2012, Eurostat Official Statistics 2015 & 2016

Most-common approach to interactions

Pro-social



Passive-social



Privacy-seeking



Scope of conventional design

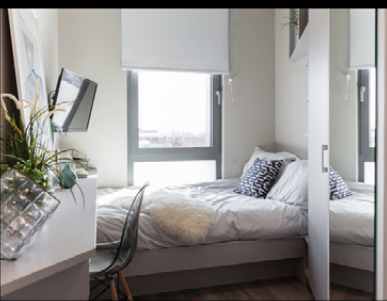

Nuanced approach to interactions

Pro-social



Passive-social



Privacy-seeking



Scope of proposed project

Curating spaces of restoration



Anne Lacaton, City Manifesto, Mulhouse Social housing, 2005



Curating spaces of personality

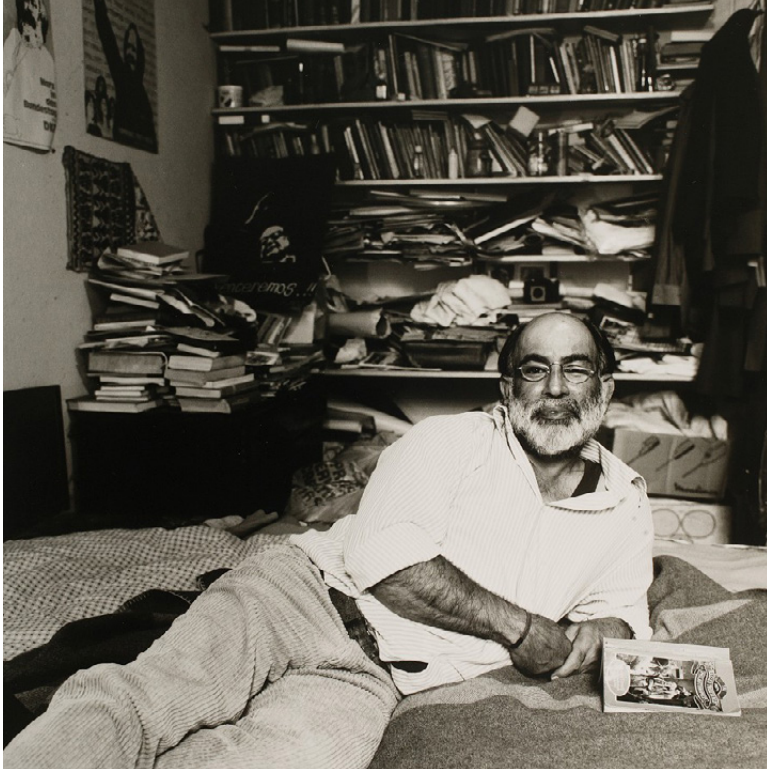

"Marchmont"



"The Grange"

*"People in their environments", Edinburgh, 1986-7,
photography project by Graham Clark*

Not inhabiting over-designed space



The Student Hotel, Amsterdam



The Collective Co-Living, London

Industrial Economy



Services and Knowledge
Economy



Shared Economy



House as Home



House as Asset



"Living as a Service"

Foodstore

Library

Gym

Cafe





SS Co Living



"Zoku" Co-Living, Amsterdam

Is 'luxury co-living' a solution to loneliness in big cities?

Could student hall-style accommodation for young professionals tackle loneliness in big cities?



The Collective Co-Living, London

Site and Response

- Population of the inner city to **at least double** (from 6,000 to 12,000 inhabitants)
- A **25% increase** in the international population
- *"We will not accept a dichotomy in Eindhoven"*



**BINNENSTAD
EINDHOVEN**

**INTER-
NATIONALE
HOTSPOT**

en de weg daarnaartoe

Binnenstadvisie
Eindhoven 2025

Versie
14 juli 2016

 EINDHOVEN

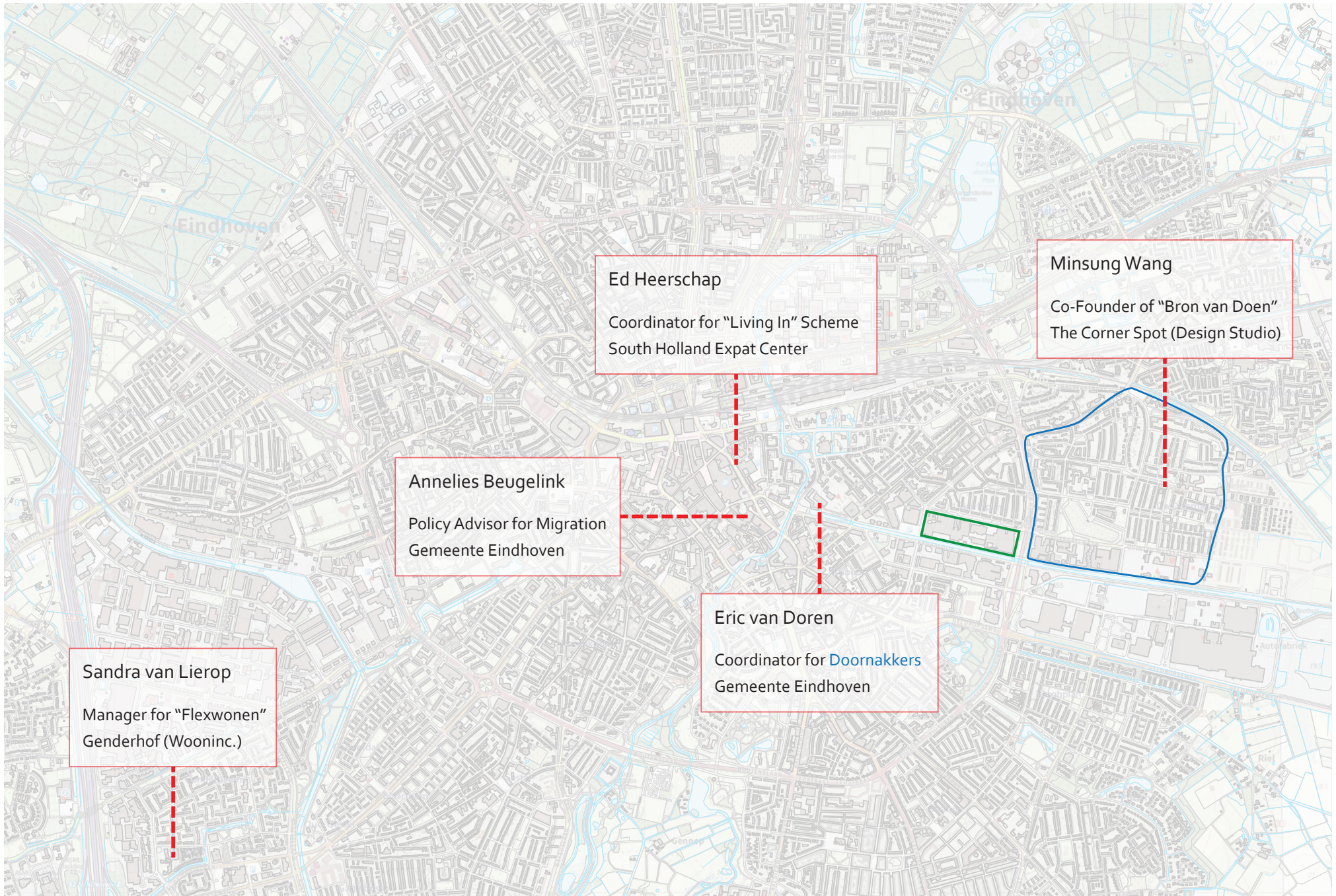

Ed Heerschap
Coordinator for "Living In" Scheme
South Holland Expat Center

Minsung Wang
Co-Founder of "Bron van Doen"
The Corner Spot (Design Studio)

Annelies Beugelink
Policy Advisor for Migration
Gemeente Eindhoven

Sandra van Lierop
Manager for "Flexwonen"
Genderhof (Wooninc.)

Eric van Doren
Coordinator for **Doornakkers**
Gemeente Eindhoven



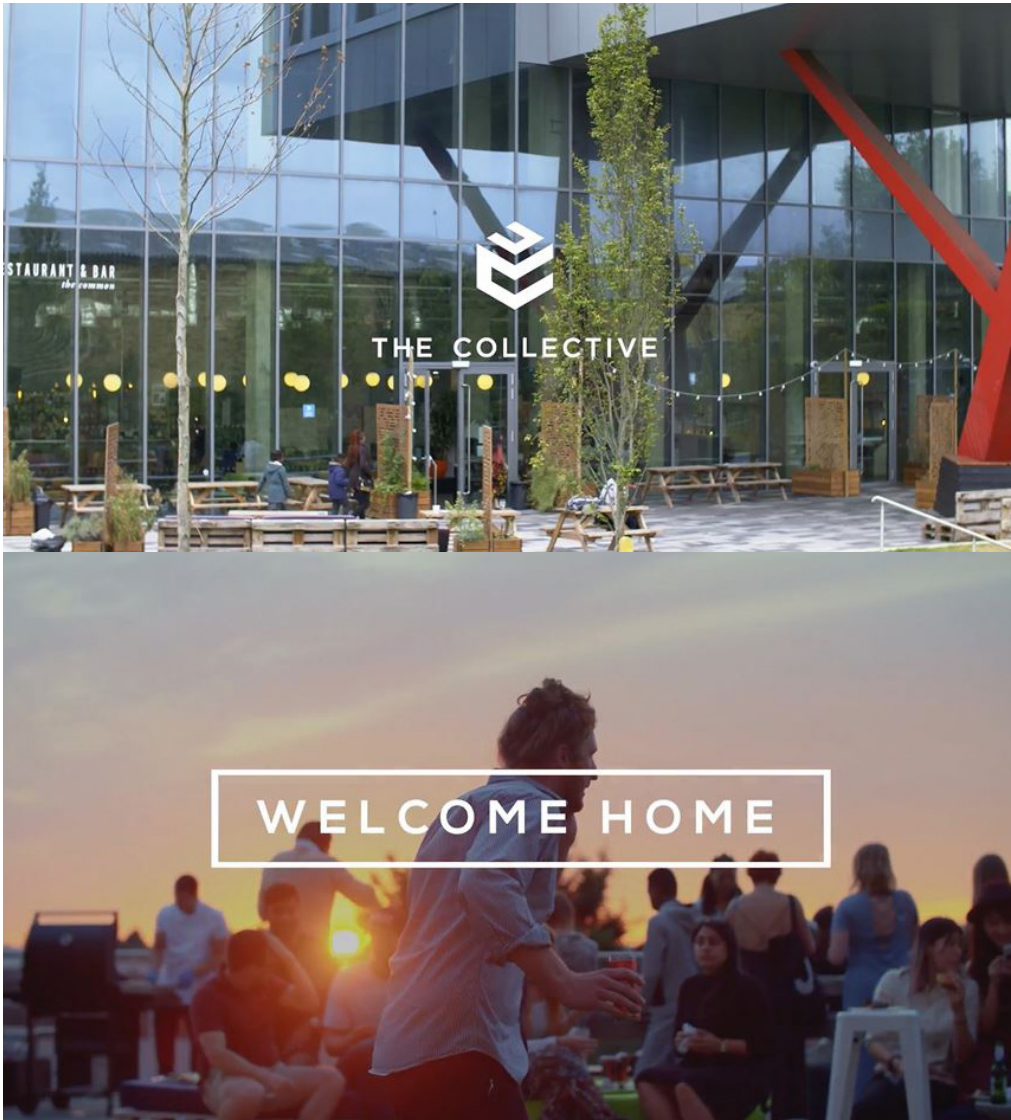

"Welcome Home", The Collective Partners LLP

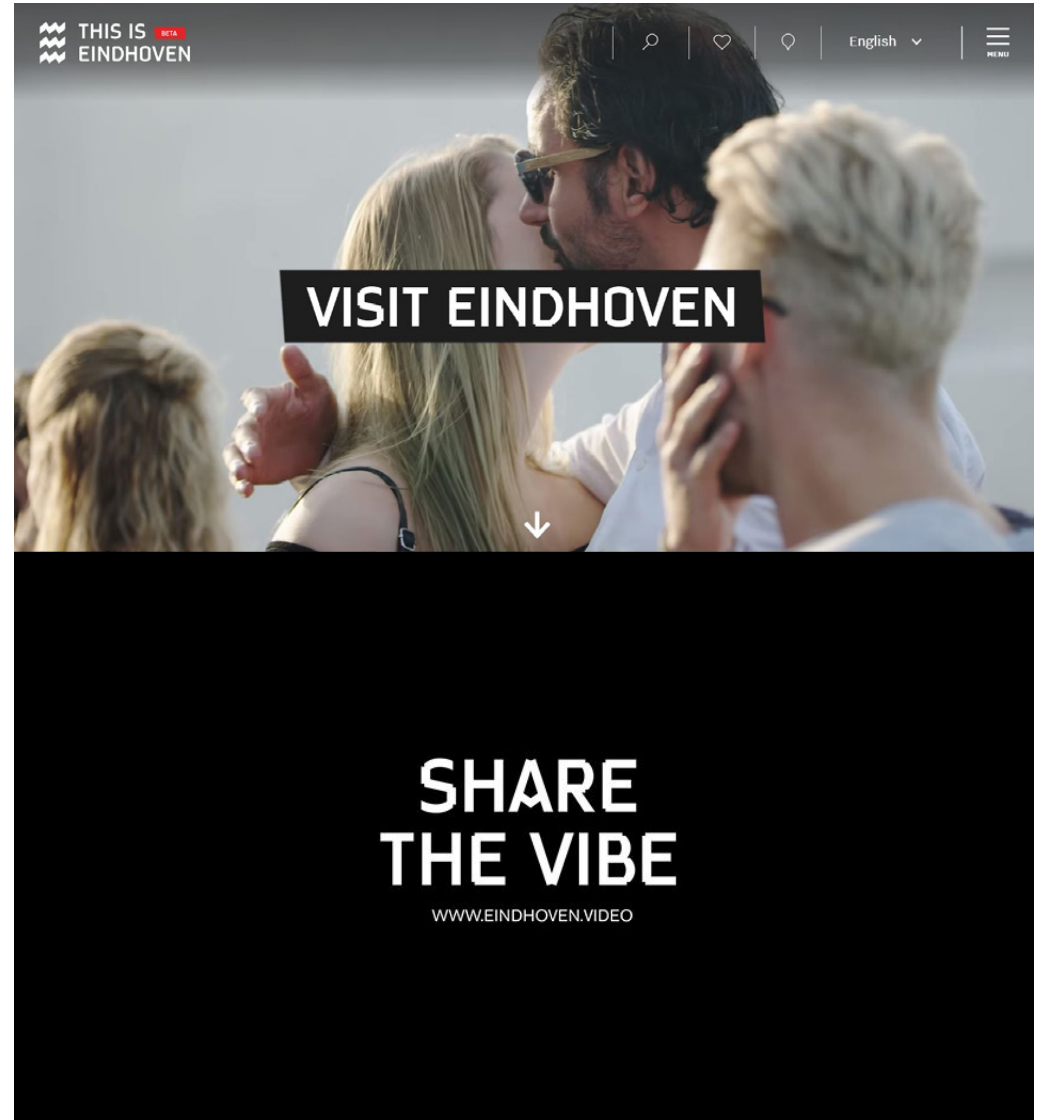

"This is Eindhoven", Gemeente Eindhoven

'Living laboratories': the Dutch cities amassing data on oblivious residents



▲ Using a smartphone in Utrecht, where €80m has been invested in data-driven management. Photograph: Alamy

In Eindhoven and Utrecht smart tech is tackling traffic, noise and crime. But with privacy laws proving futile and commercial companies in on the act, are the plans as benign as they seem?



Mechanical surveillance



Trust 

Rules 

Passive surveillance



Trust 

Rules 



Car-free neighbourhoods

Strong sense of identity



GWL Terrein, Amsterdam

1993 - 1998

Box-of-chocolates urbanism



Funenpark, Amsterdam

2002-2009

Soft edges



GWL Terrein, Amsterdam

2018



Funenpark, Amsterdam

2018

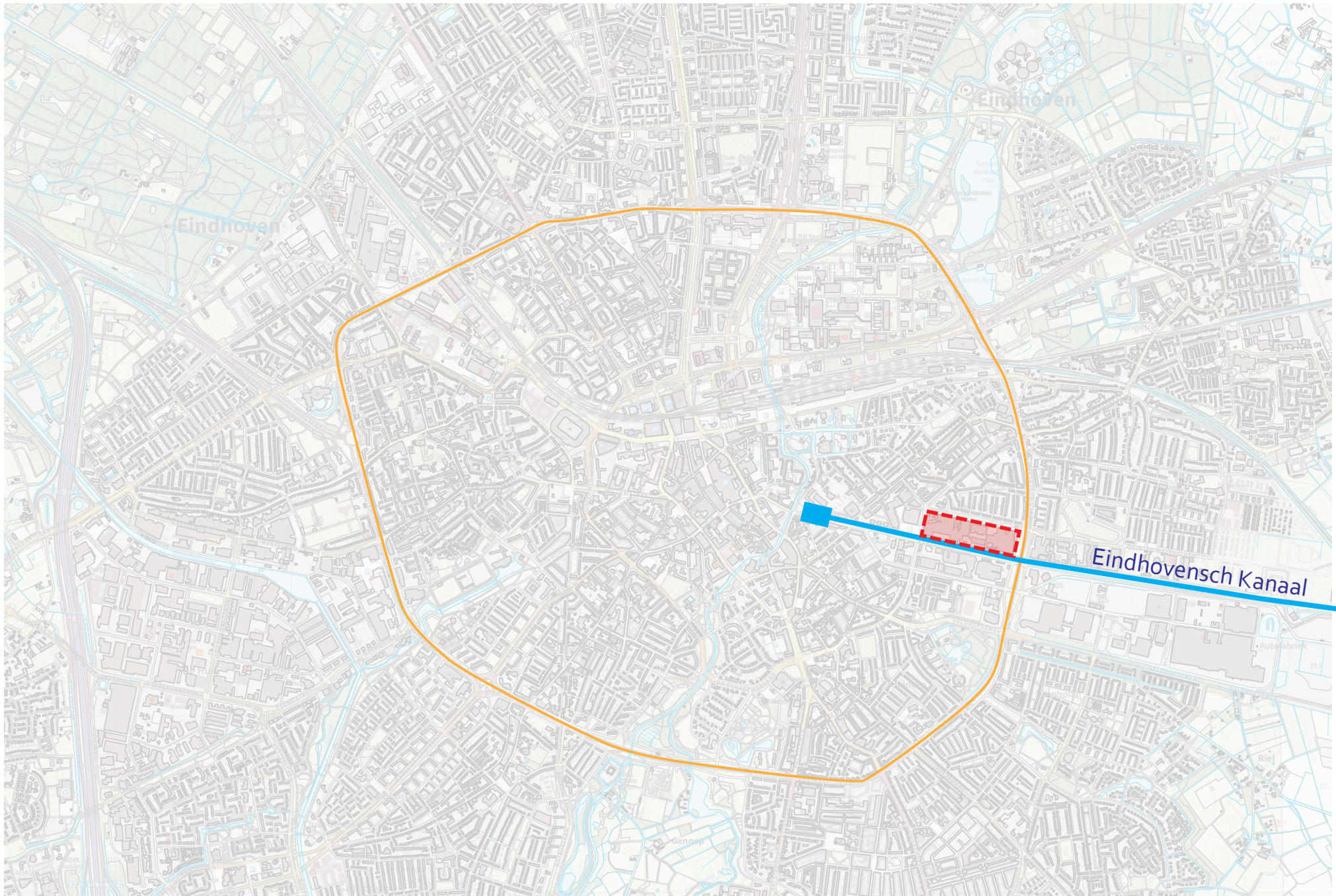



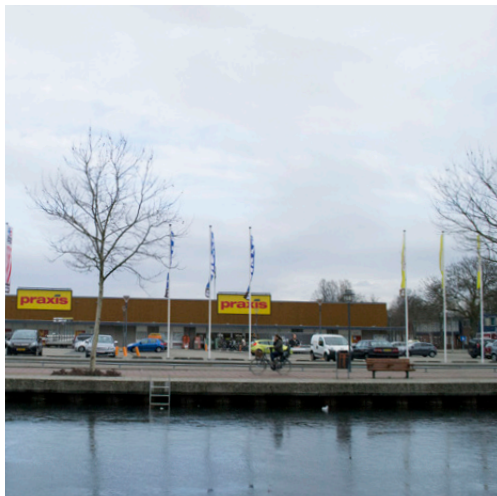
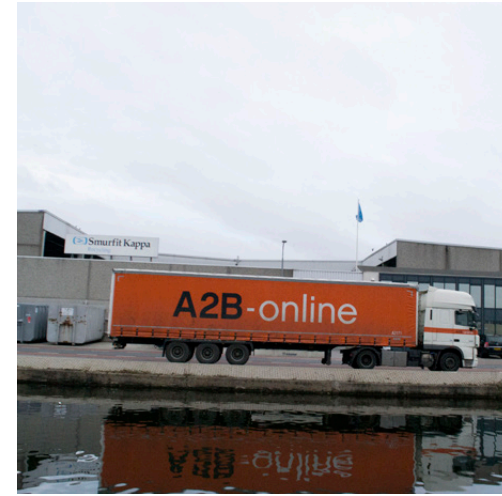



PACCARPARTS

VSP DAF



TEUBEN

INT. TRANSPORT
OP-EN OVERSLAG
TER APEL-TER APELKANAAL



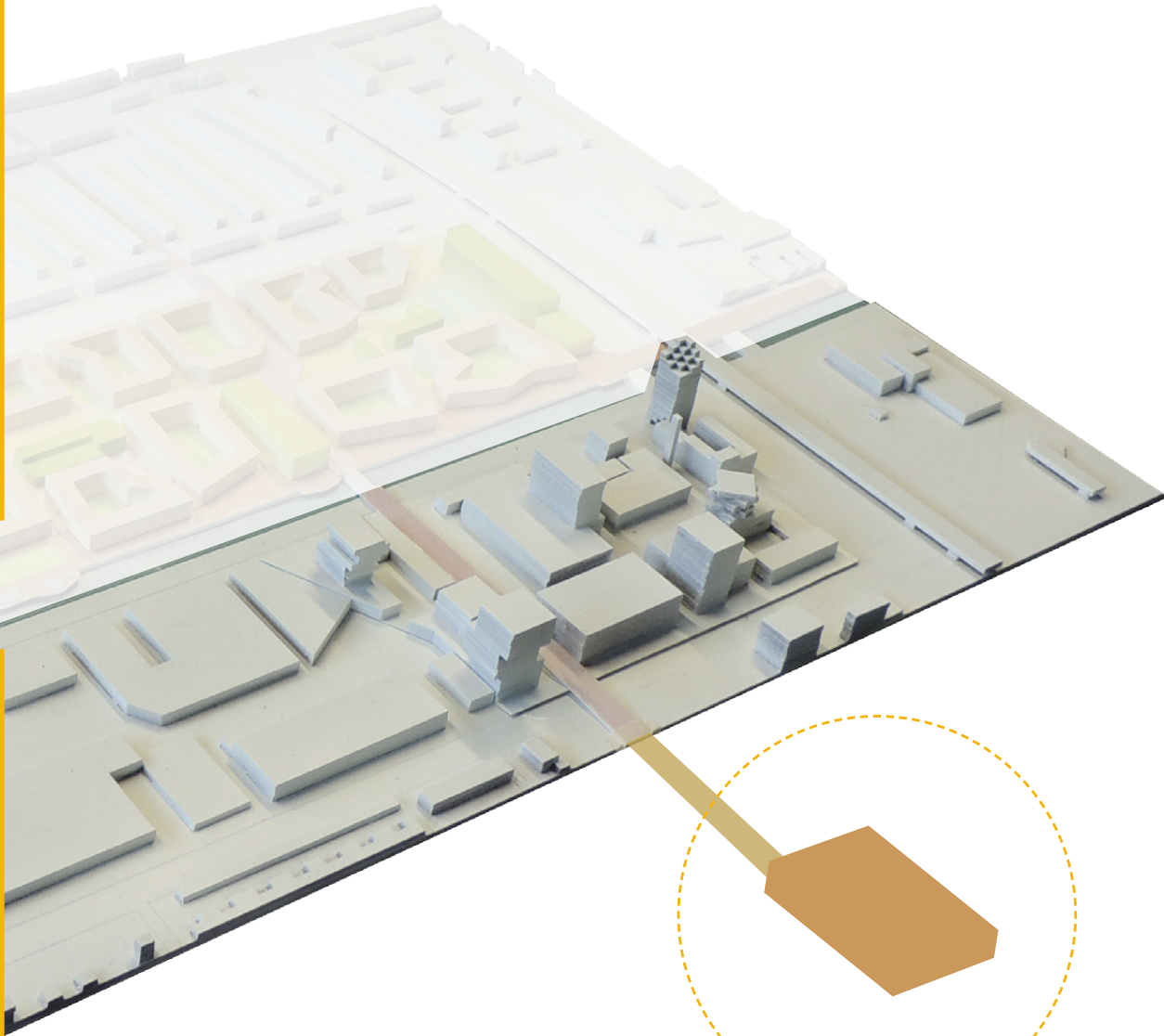

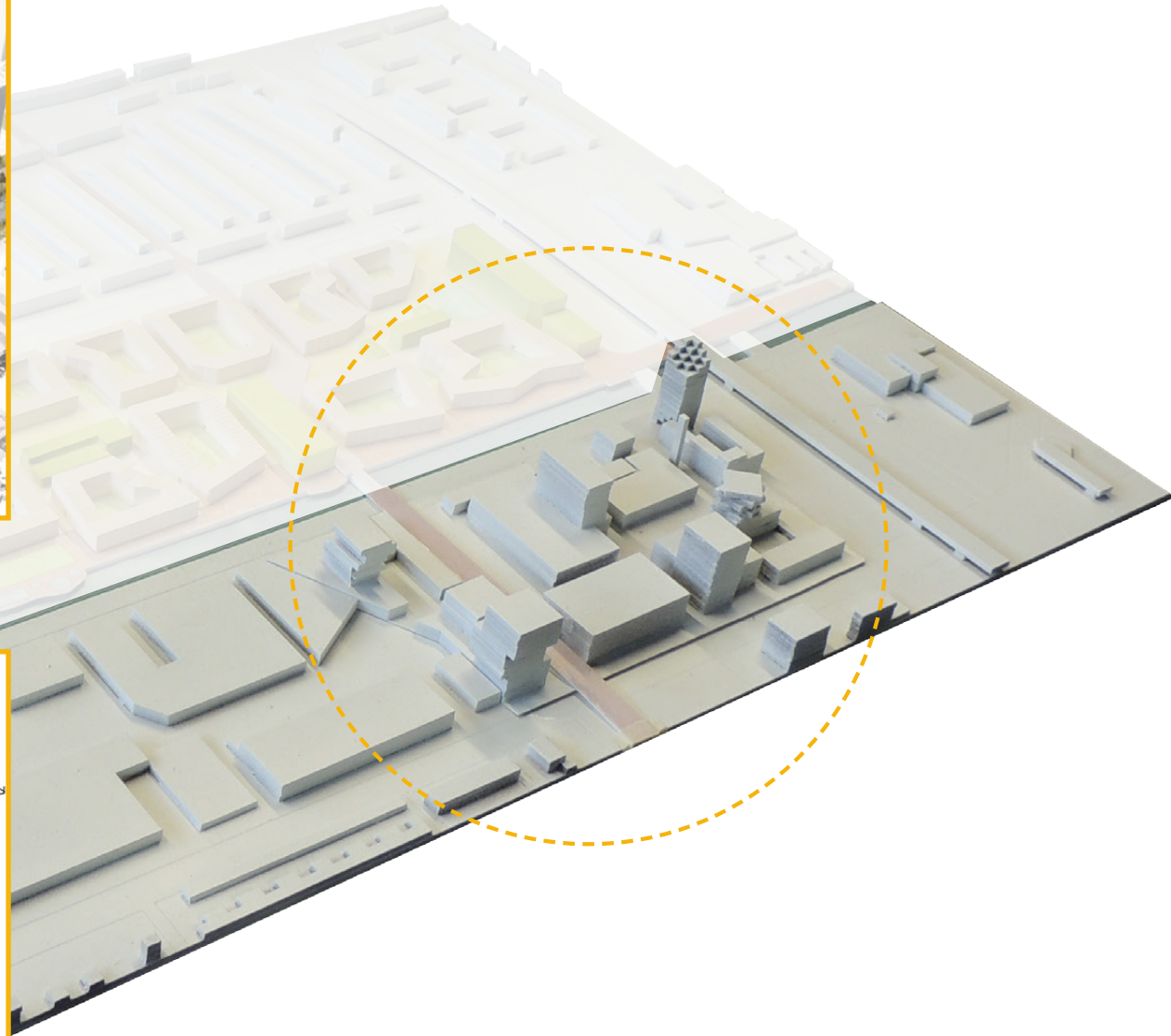



Design - Urban Scale

What are people willing to share?

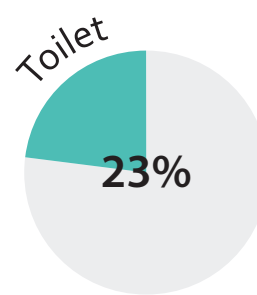
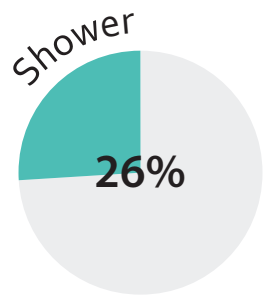
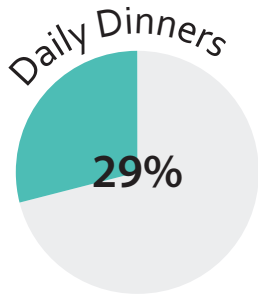
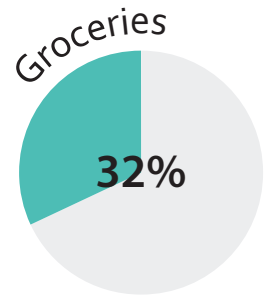
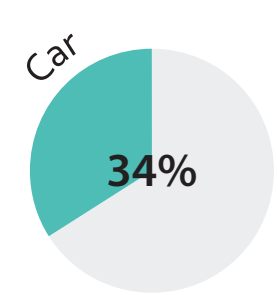
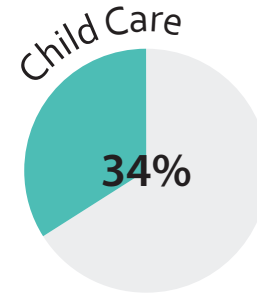
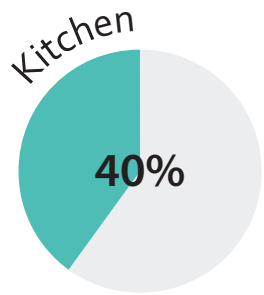
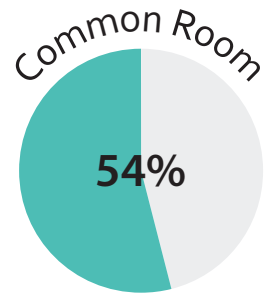
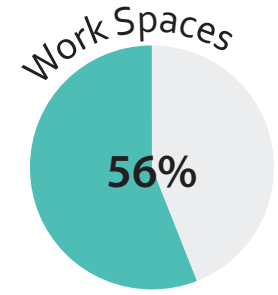
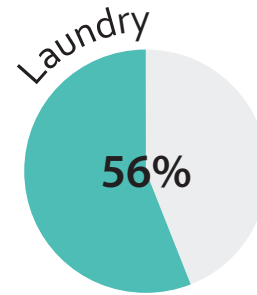
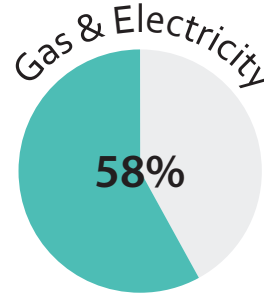
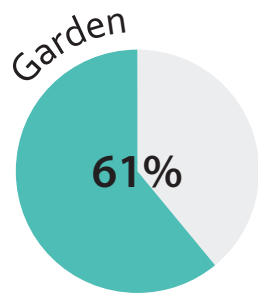
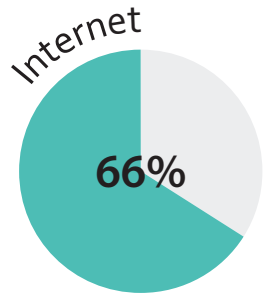

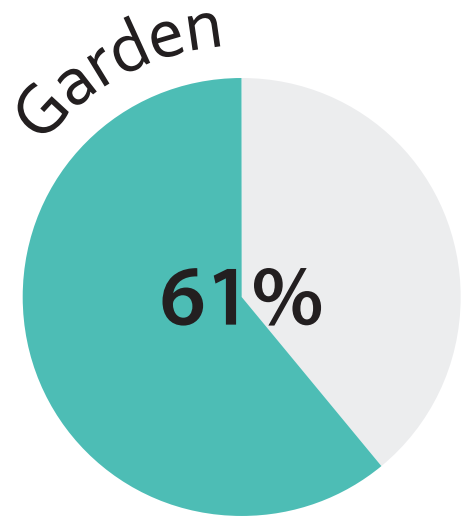

“Biophilia”: diverse nature as a restorative force



Restorative Capacity 



Restorative Capacity 

Partitioned space



Shared space with added value



Sydney's "Boomburbs"

2006 onwards

N Street Co-Housing

Davis, California, 1986 onwards

“Monastery within a monastery”



Salisbury Cathedral, England

“Box of chocolates” urbanism



Funenpark, Amsterdam

Urban coherency

+

Block identity

Consistent for each block:

Passive surveillance measures:

- Between 50 and 150 residents
- Shared garden with public access

Architecture:

- Retains the general outline of urban plan
- Grass-covered roof
- Wood or wood-hybrid structure

Unique for each block:

Social:

- Management scheme
- Choice/mix of dwelling types
- Scheme for the ground floor

Architecture:

- Depth of plan
- Design/materials of the facade
- Character of the shared garden

Consistent for each block:

Passive surveillance measures:

- Between 50 and 150 residents
- Shared garden with public access

Architecture:

- Retains the general outline of urban plan
- Grass-covered roof
- Wood or wood-hybrid structure

Unique for each block:

Social:

- Management scheme
- Choice/mix of dwelling types
- Scheme for the ground floor

Architecture:

- Depth of plan
- Design/materials of the facade
- Character of the shared garden



TU Delft - Corporate Film 2018 'We, TU Delft'

4,989 views

👍 59 💬 5 ➦ SHARE ☰ ⋮



Koolhaas_45 4 months ago

That bloke at 1:00 looks like he really knows what he's doing - I am inspired!

👍 1 💬 REPLY

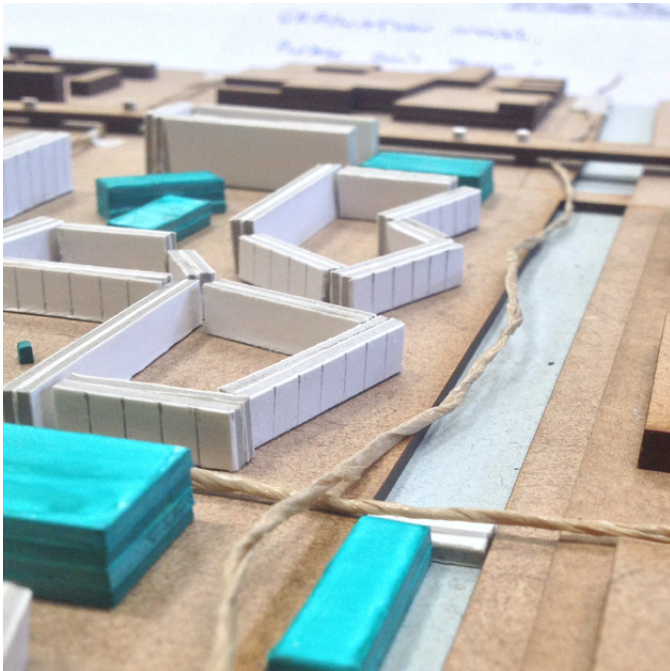



Non-residential masses

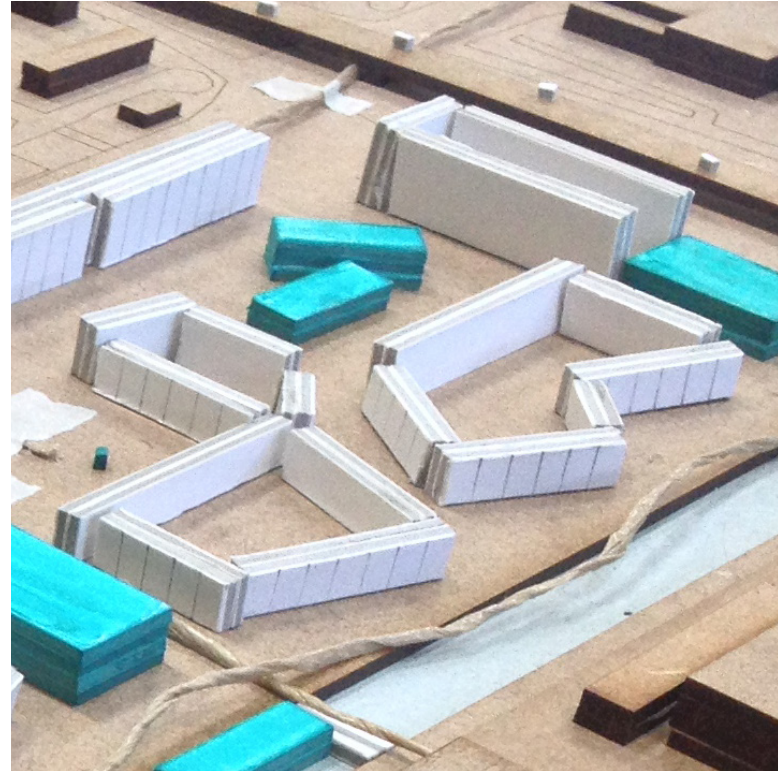

Residential blocks

Space occupiers

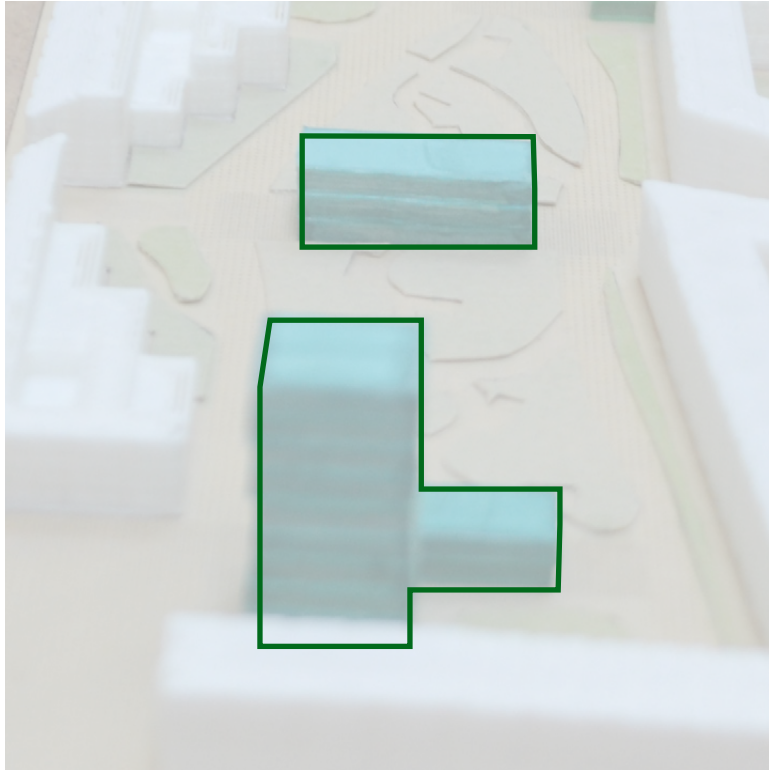

Space definers

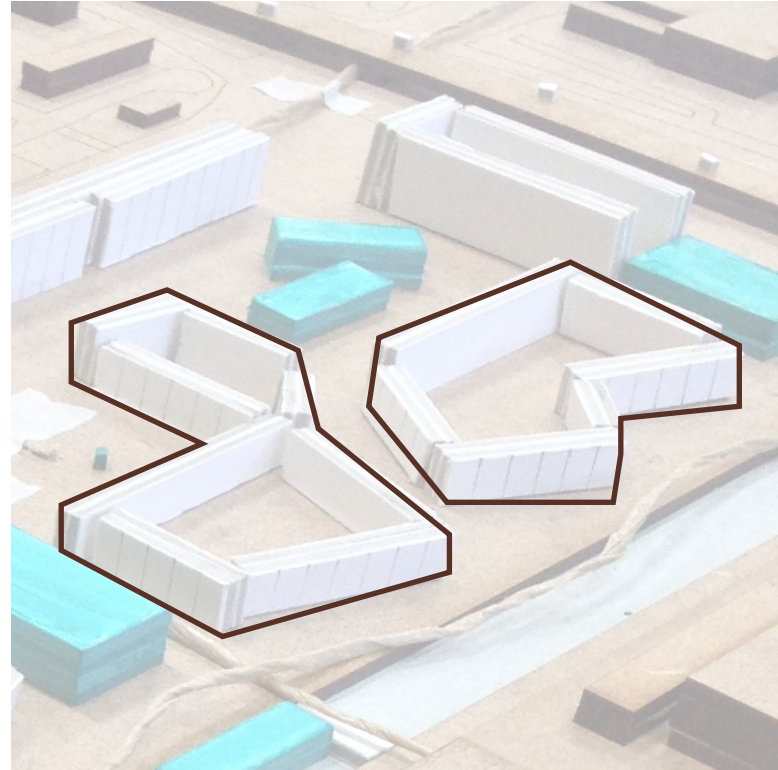

Rigid openings to “lock in” connections to nearby residential streets



Wide boulevard to the north of the site

“Open corners” to invite passersby into the neighbourhood



Northeast corner



Northwest corner

Weaving of north-south connection across the site

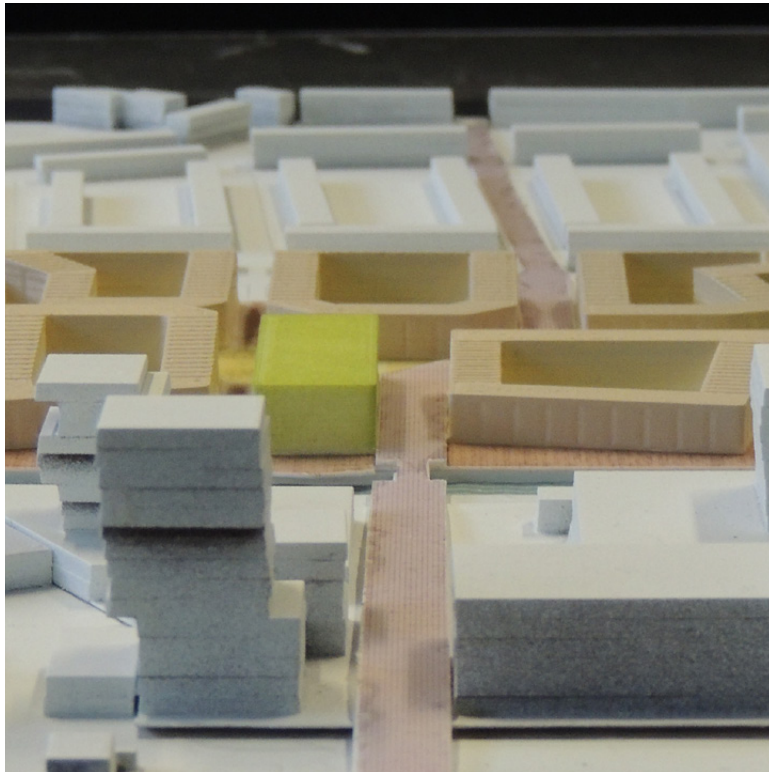

View from the Campinaterrein

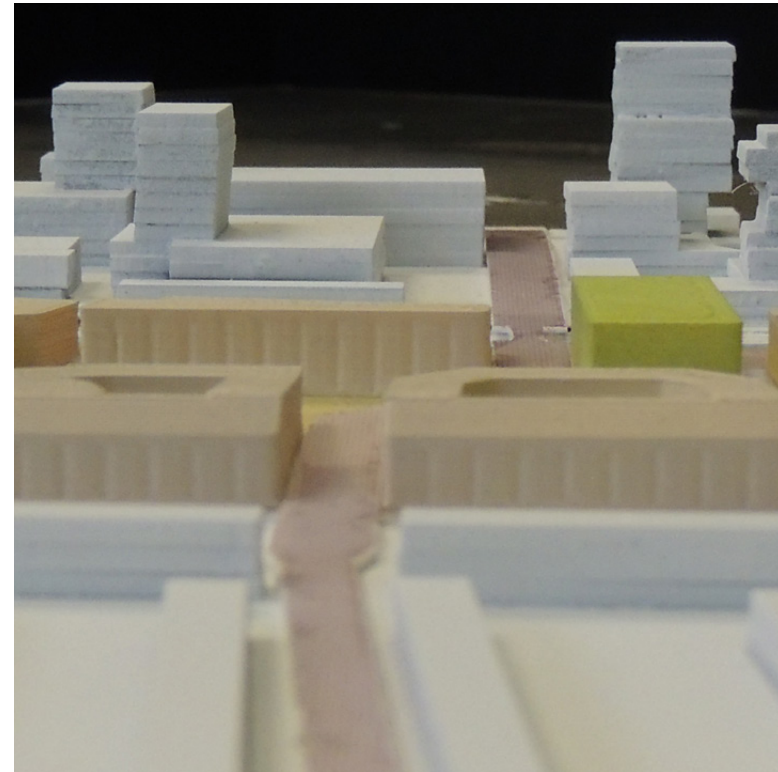

View from park to the north

Undulating profile to define the more-leisurely promenade



Canalside

Carving out wide entrances and “pockets” for playgrounds



View into donations and second-hand store

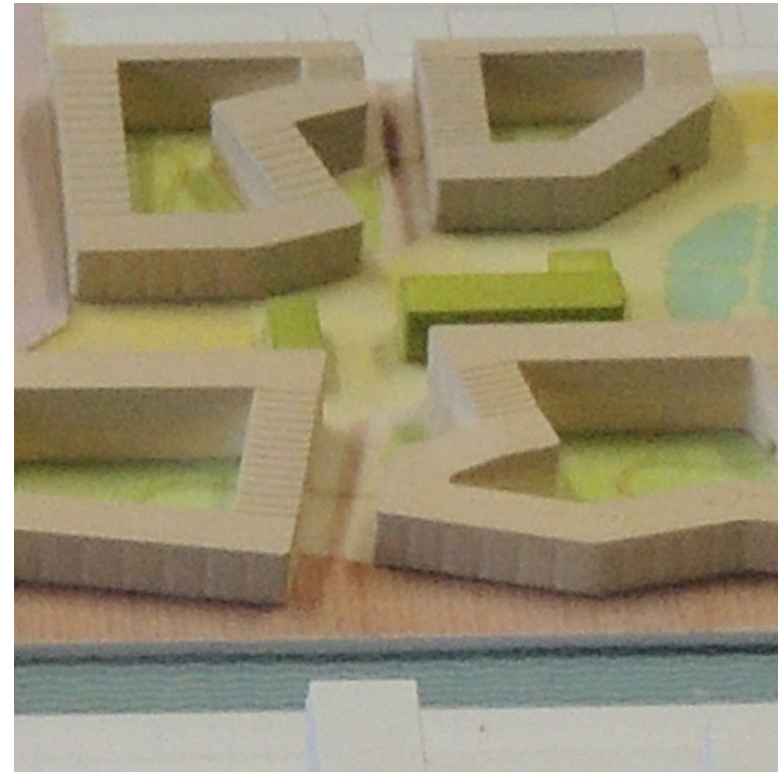

View into language and tutoring centre

Internal “street” for neighbourhood coherence



View from the east

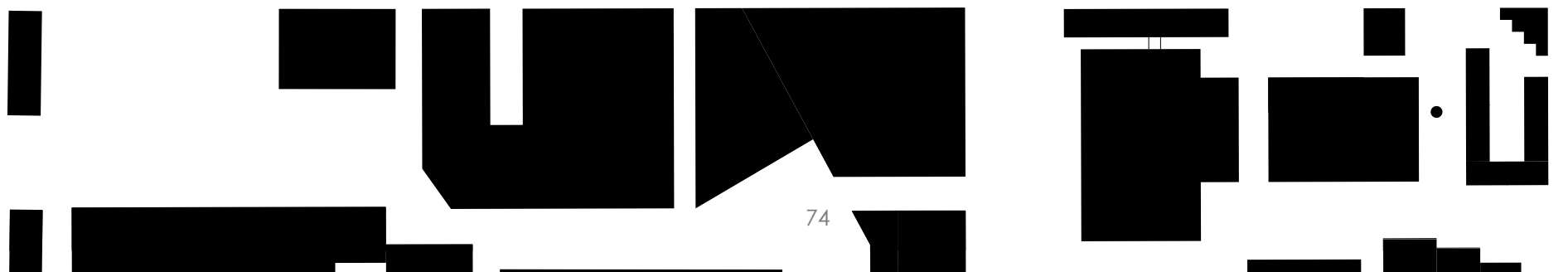
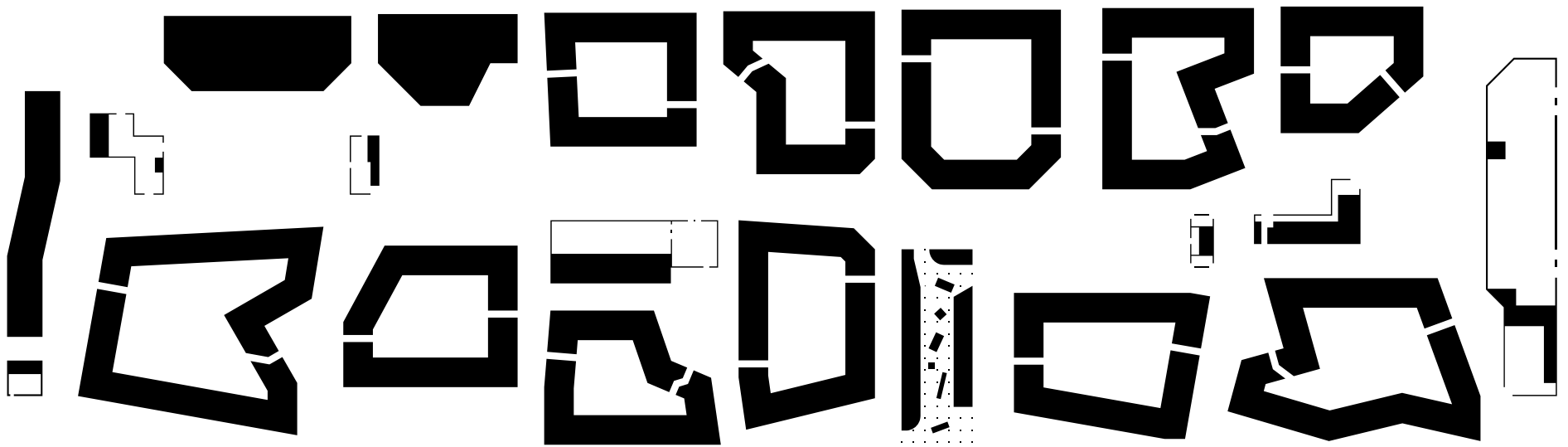



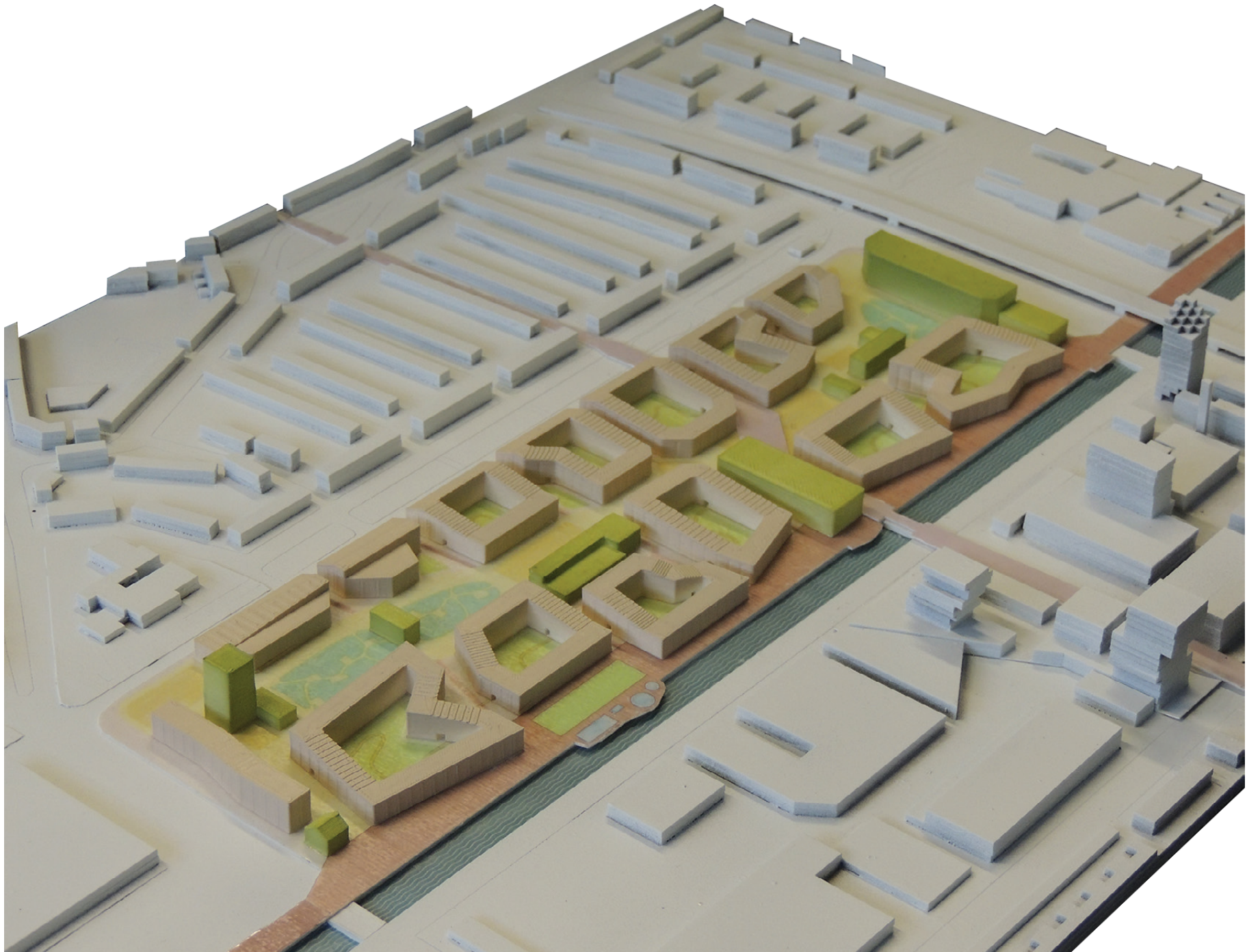

*Tools for assembling
restorative spaces*

*Platforms for volunteering
and connecting skilled people*

*Opportunities for improving
cultural understanding*

Additional functions

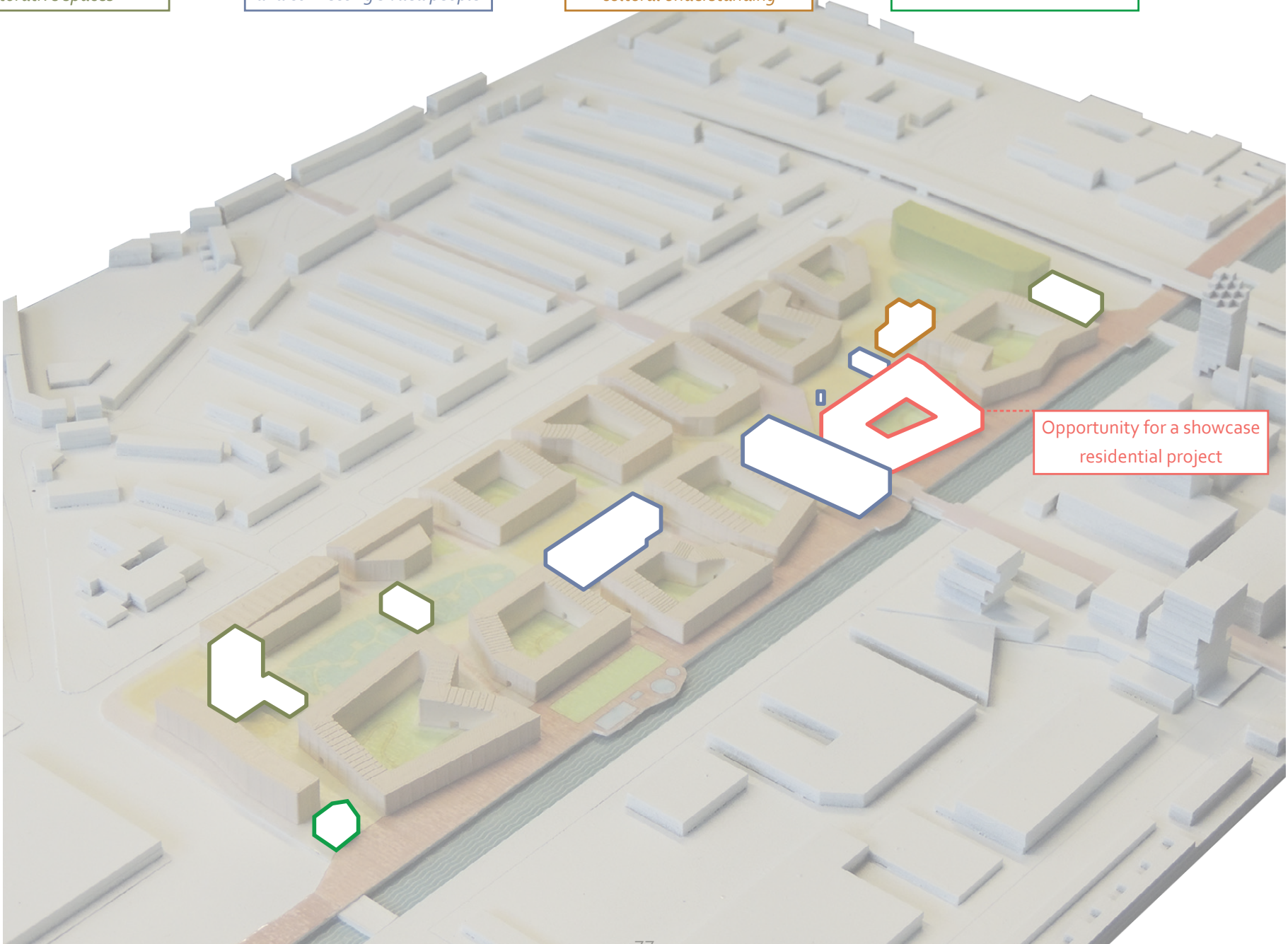

*Opportunity for a showcase
residential project*

Consistent for each block:

Passive surveillance measures:

- Between 50 and 150 residents
- Shared garden with public access

Architecture:

- Retains the general outline of urban plan
- Grass-covered roof
- Wood or wood-hybrid structure

Unique for each block:

Social:

- **Management scheme**
- Choice/mix of dwelling types
- Scheme for the ground floor

Architecture:

- Depth of plan
- Design/materials of the facade
- Character of the shared garden



Einmoven

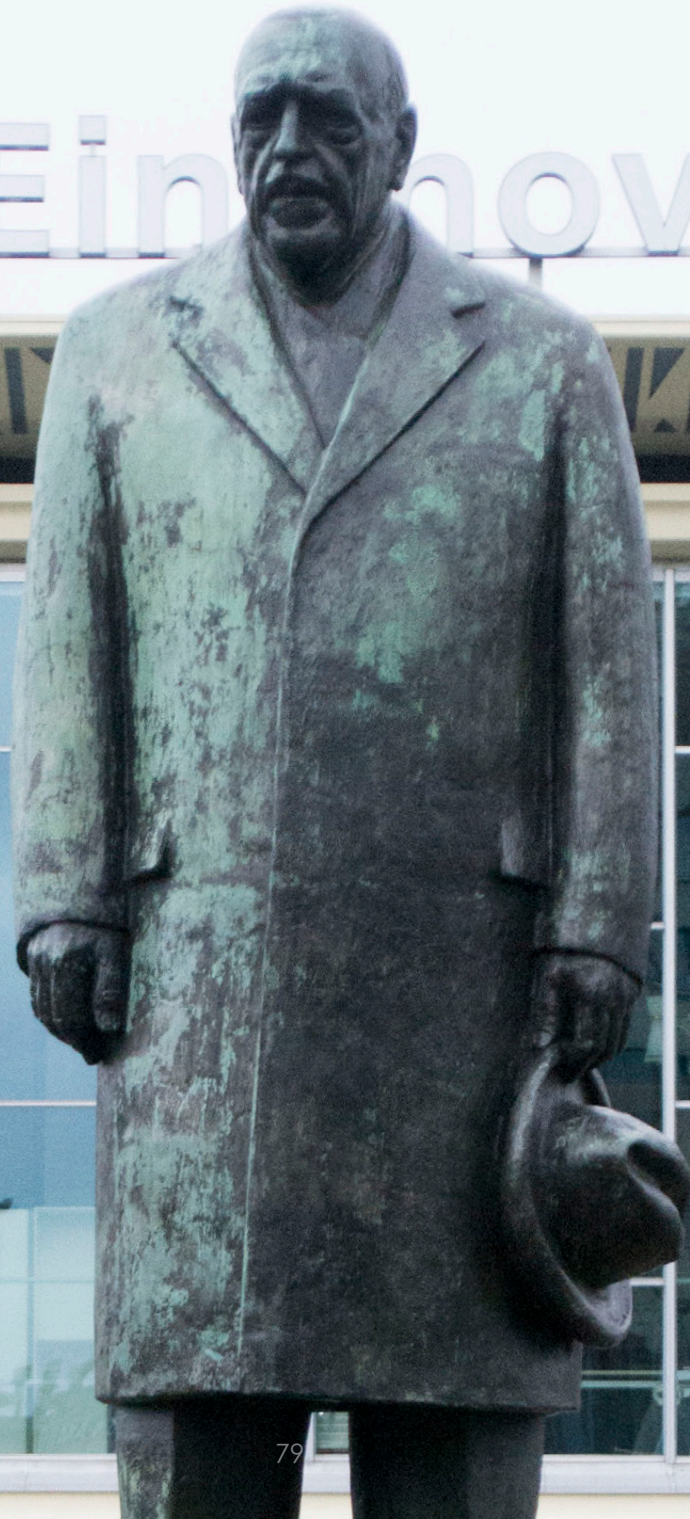

Block identity - management scheme

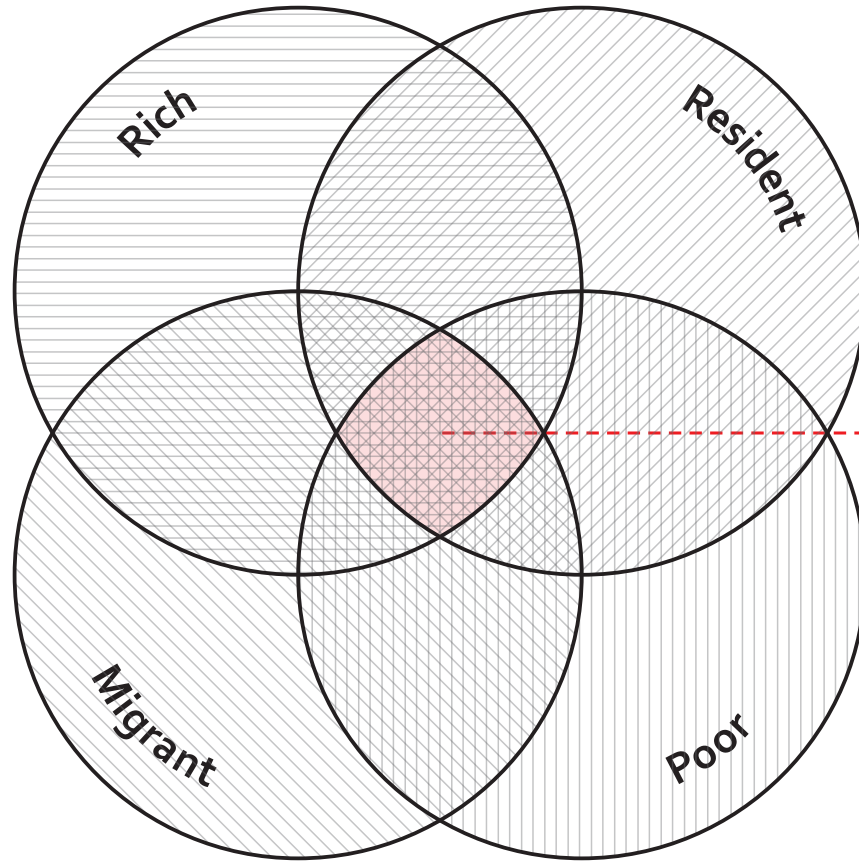

Economy of Shared Needs



Block identity - management scheme

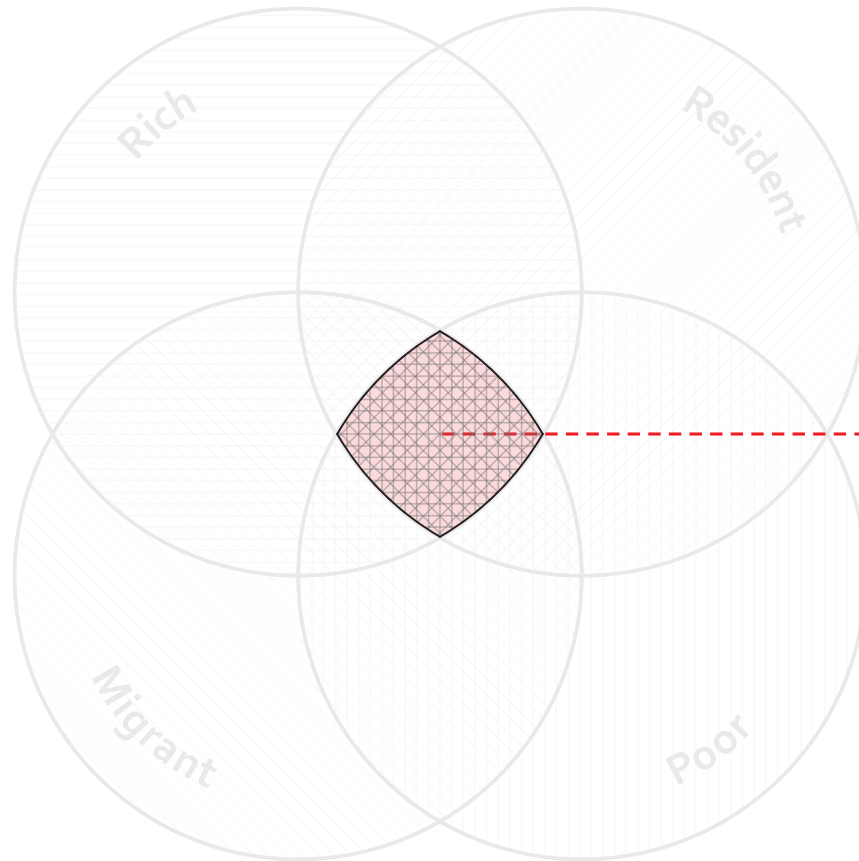

Economy of Shared Needs



Long-termers (>40%)



Feel part of something bigger than themselves

New-comers (<60%)



Feel welcome

Block identity - management scheme

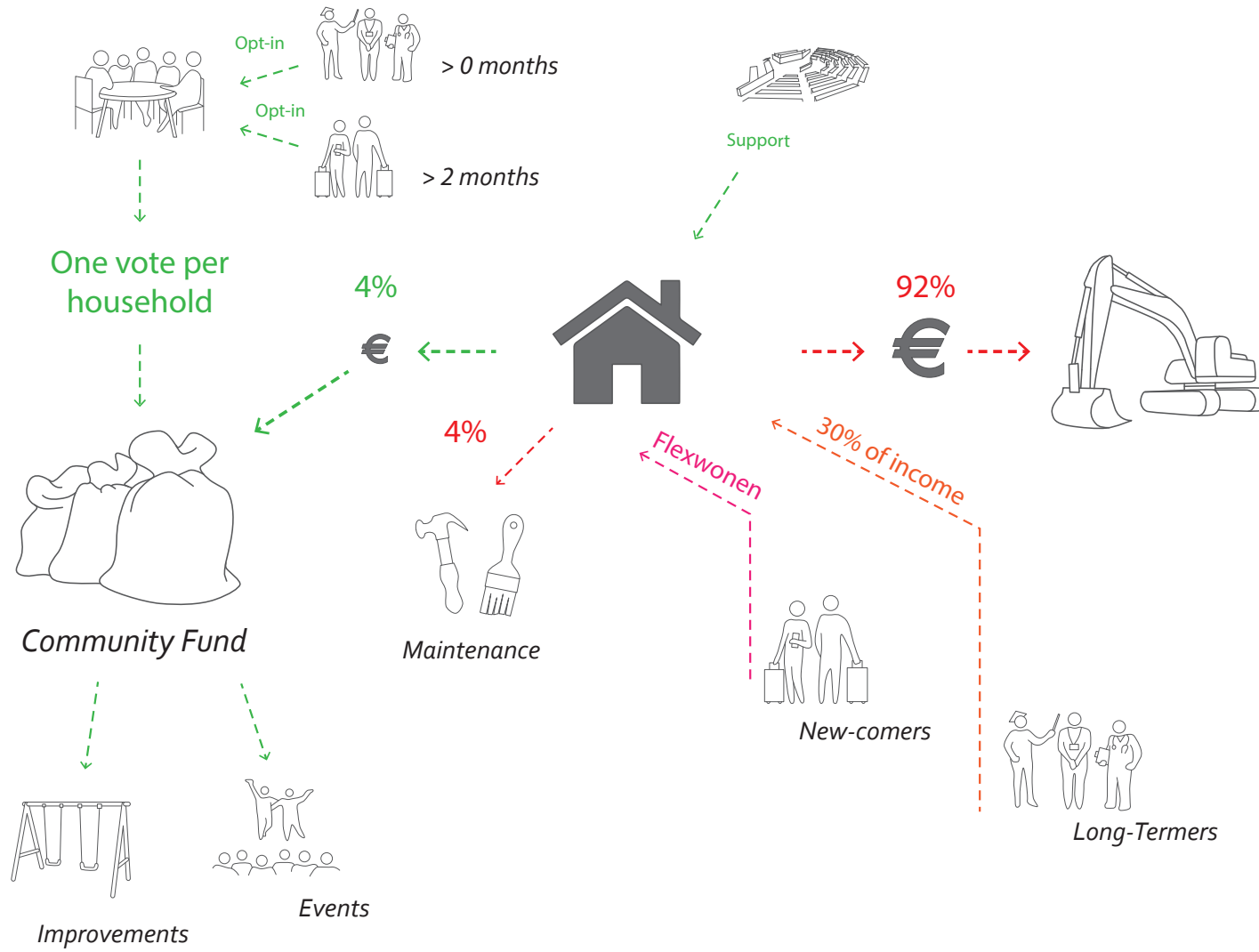

Design - Architectural Scale

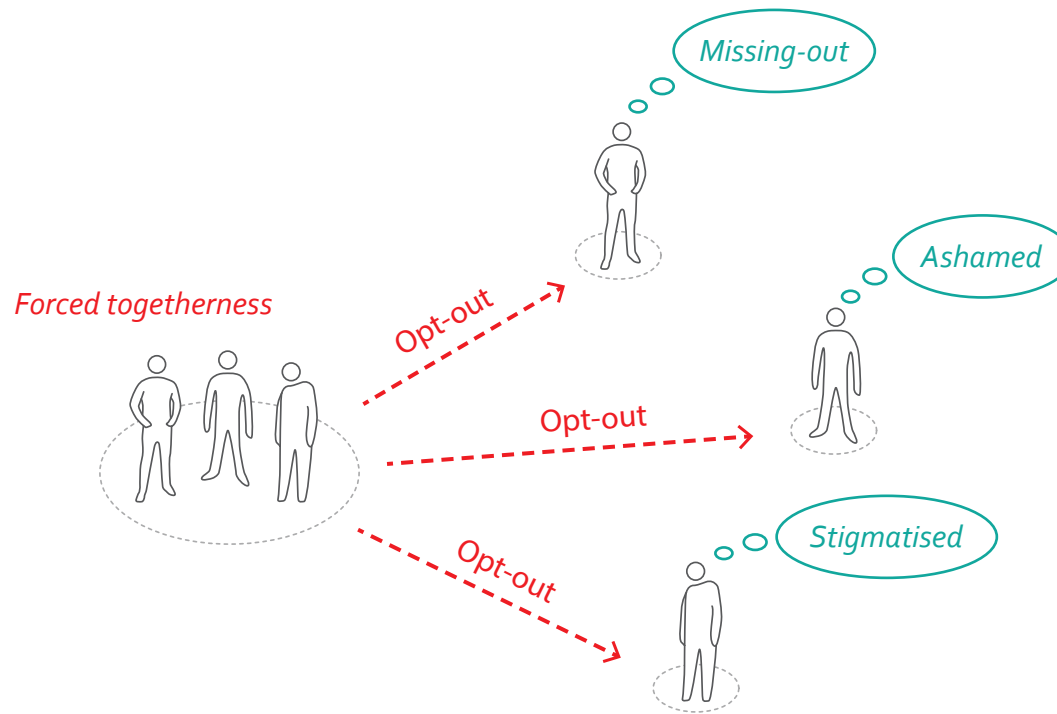

*Accepted default:
Togetherness*

*Scrutinised choice:
"Is it ok to be alone?"*

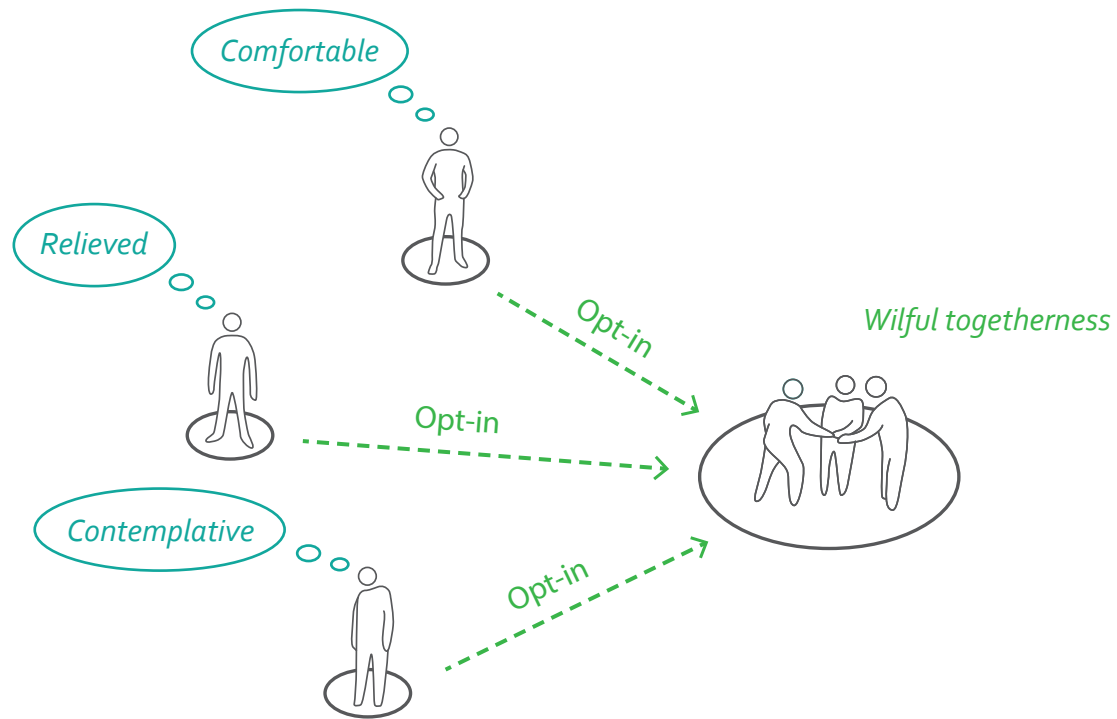

*Accepted default:
Restorative solitude*

*Accepted choice:
"How to be together?"*

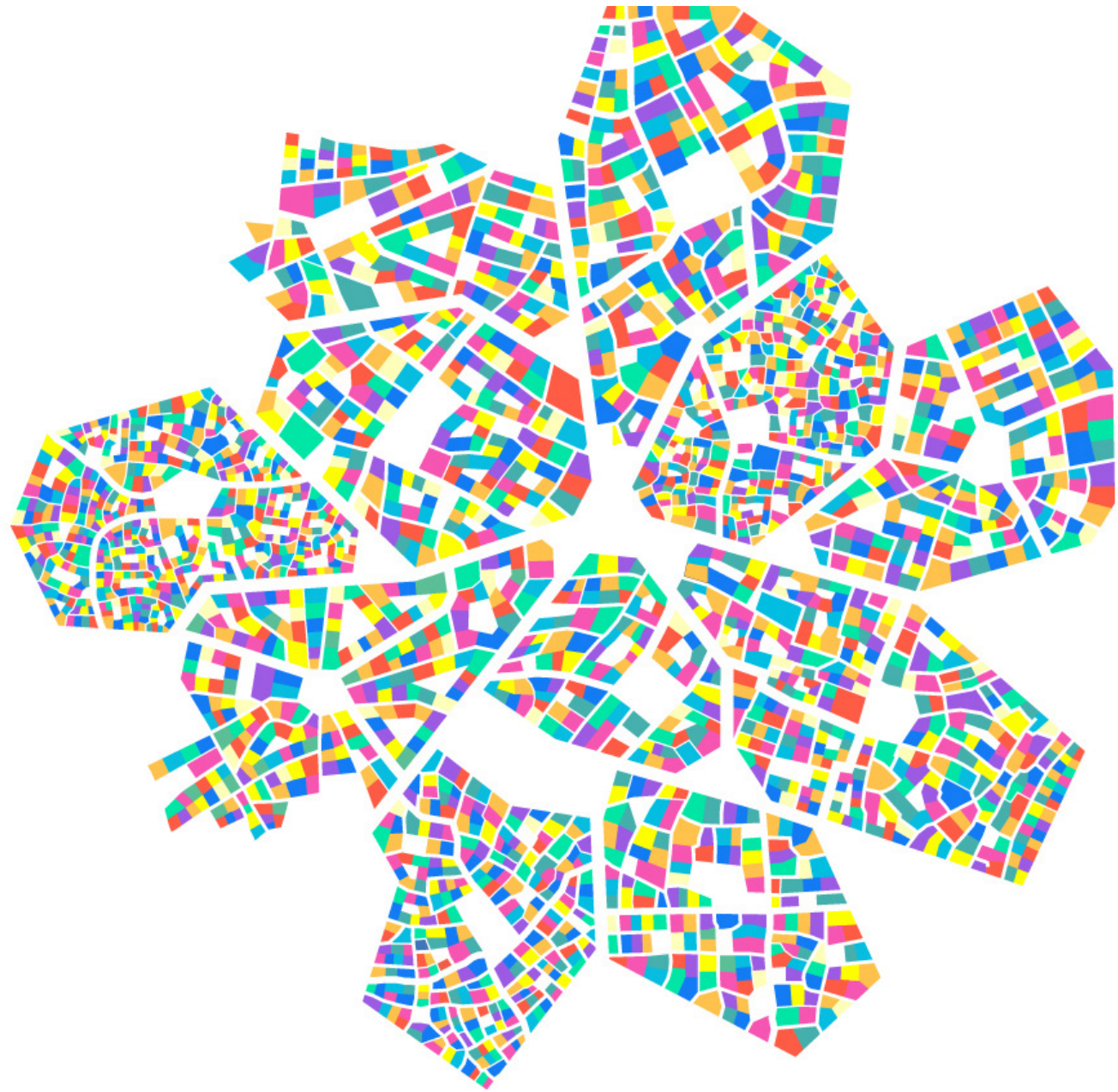

Pro-social



Passive social



Privacy-seeking

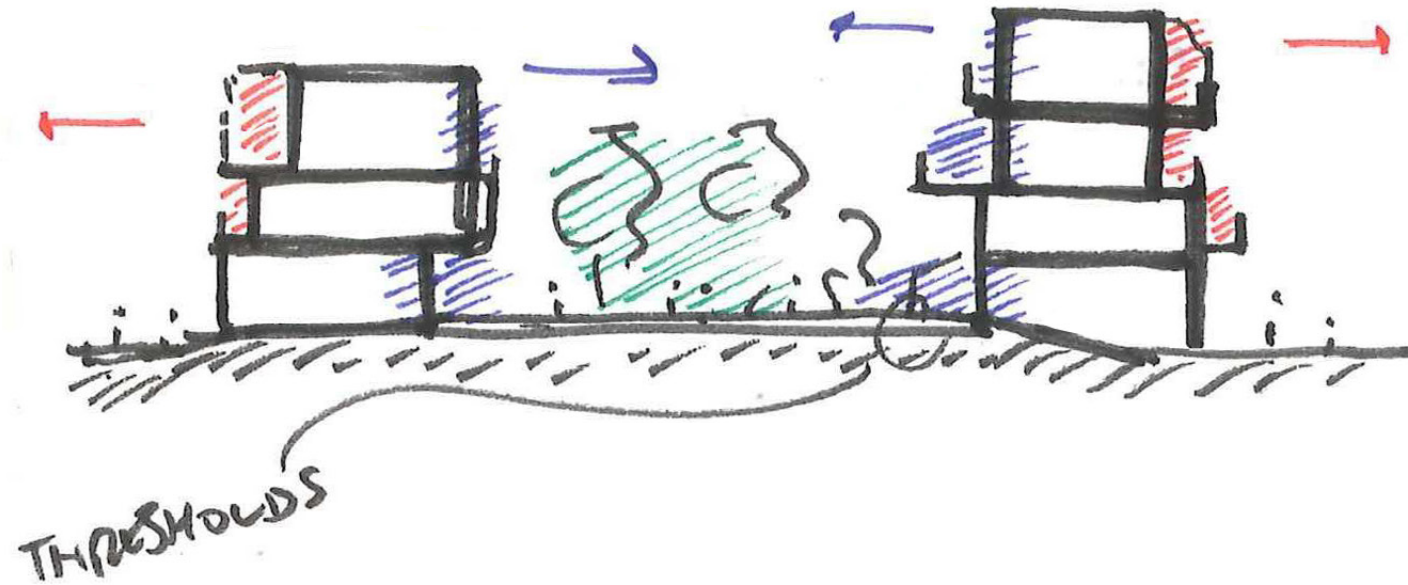

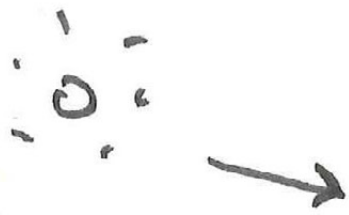

Withdraw

Connect

Withdraw

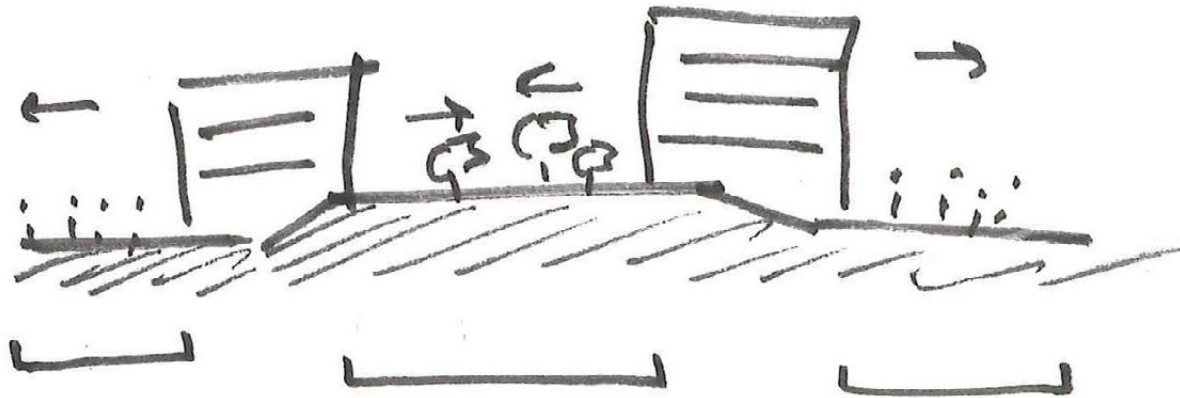

Public

Calm

Public

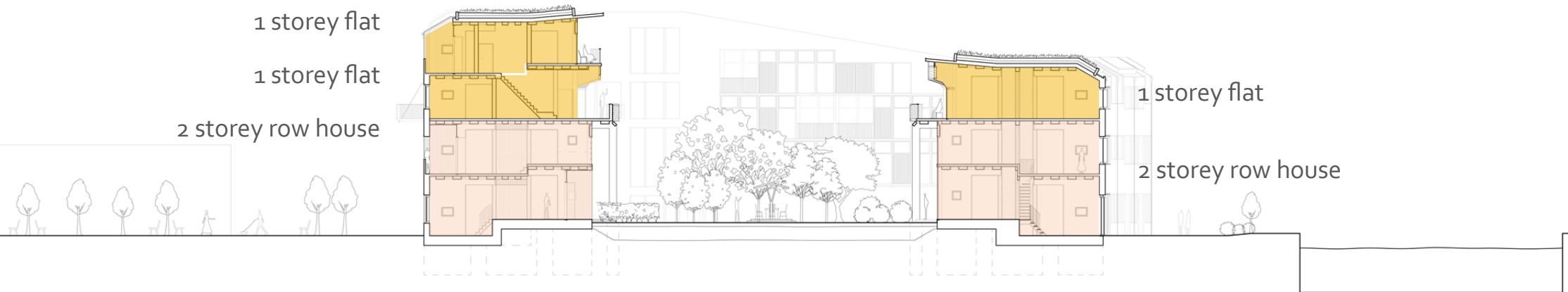

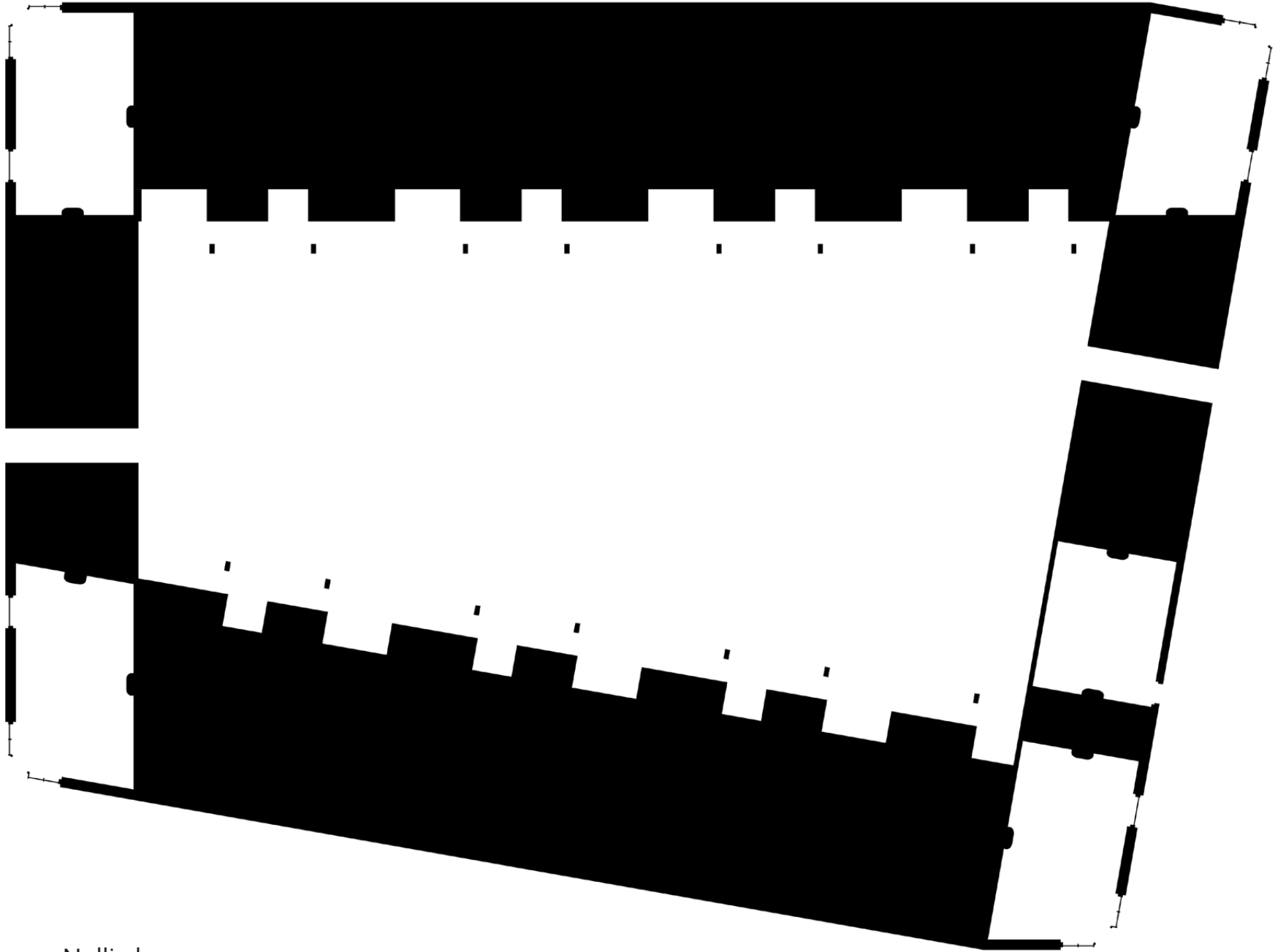

Floor 00 - Nolli plan

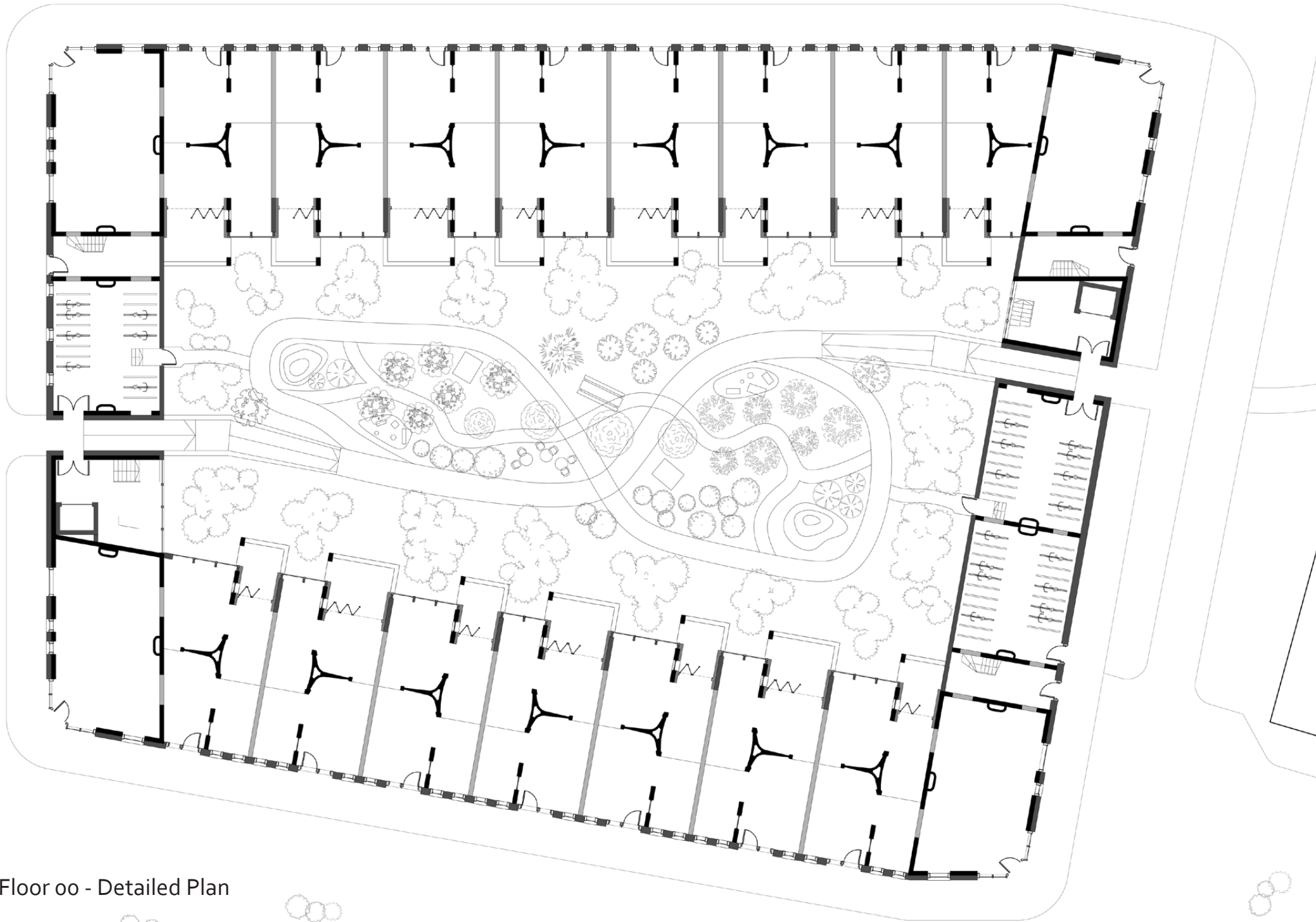

Floor 00 - Detailed Plan

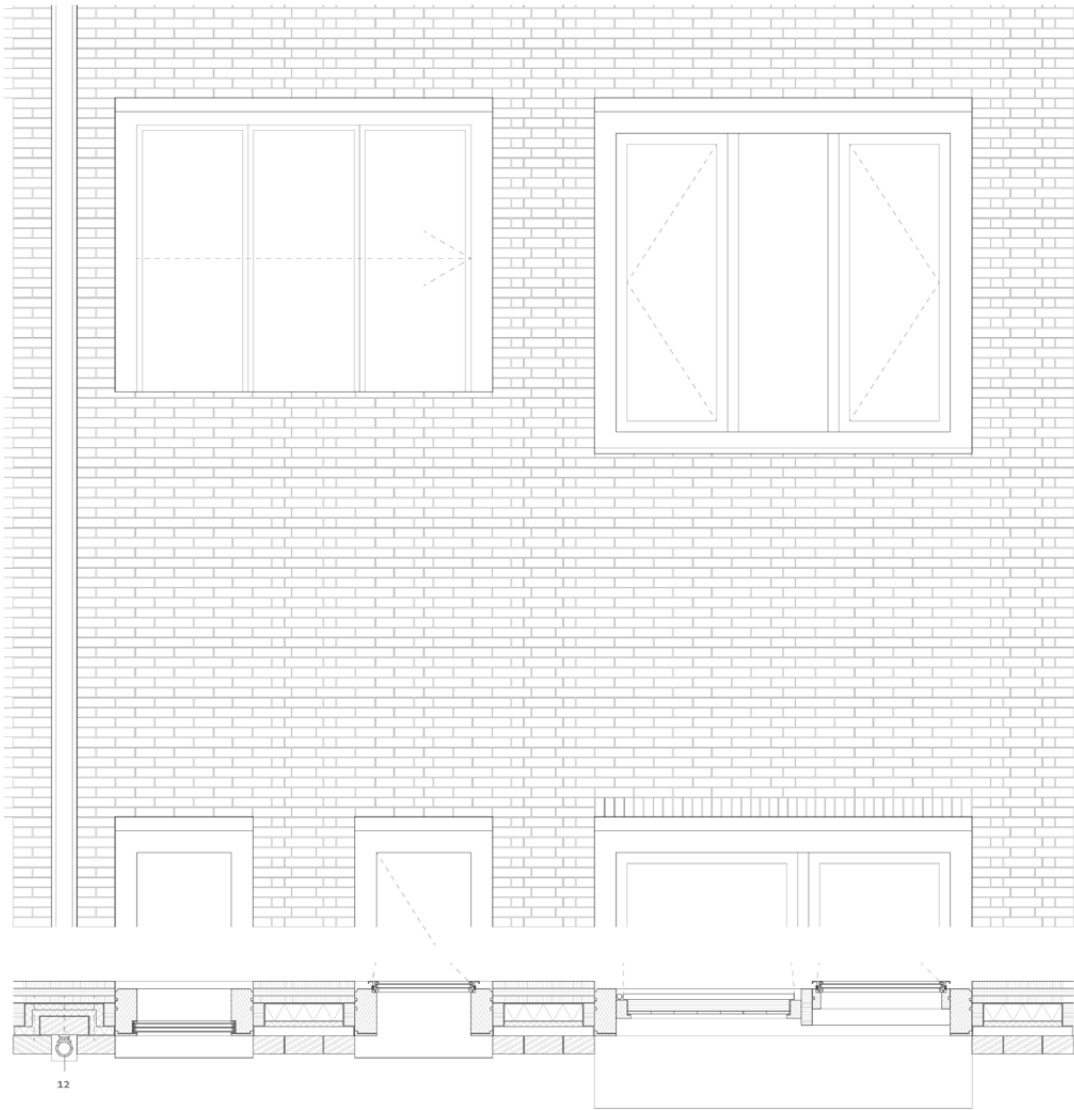

Outer Facade

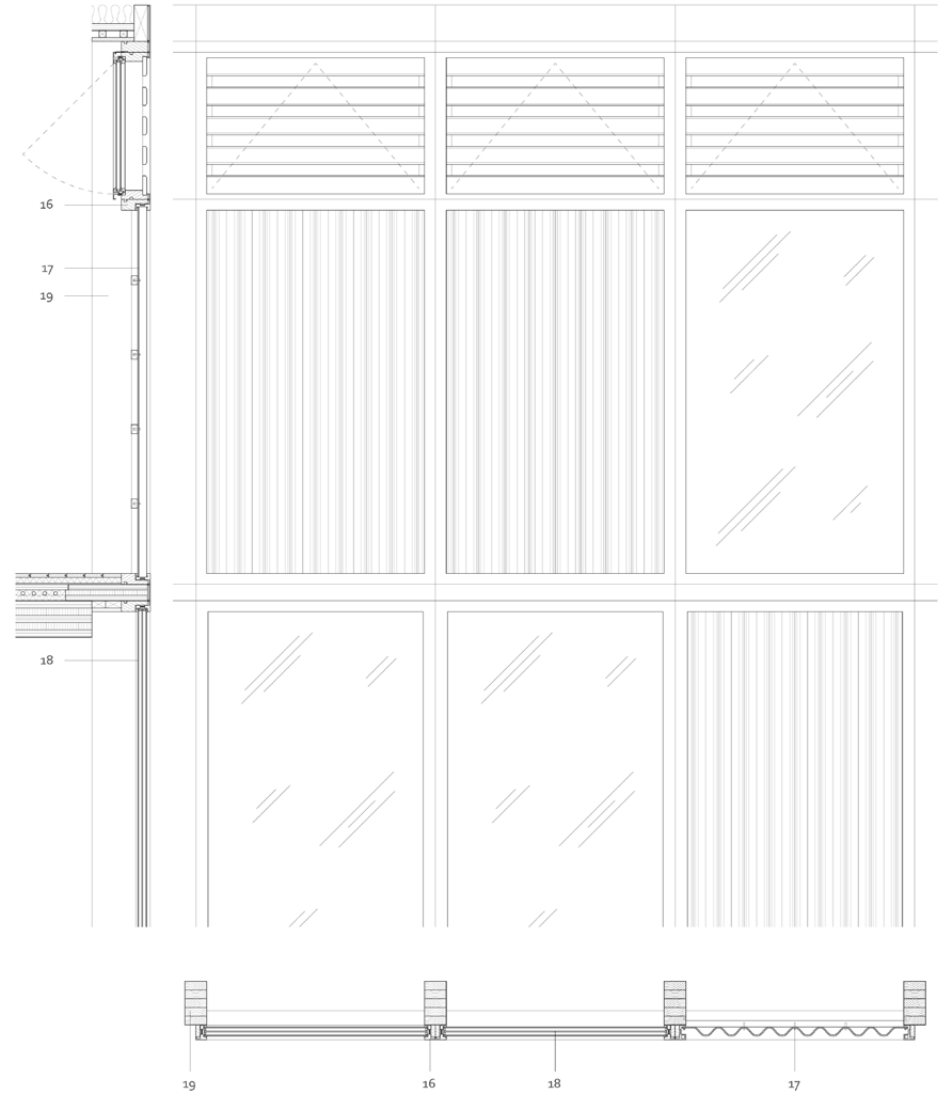

Inner Facade



Outer Facade

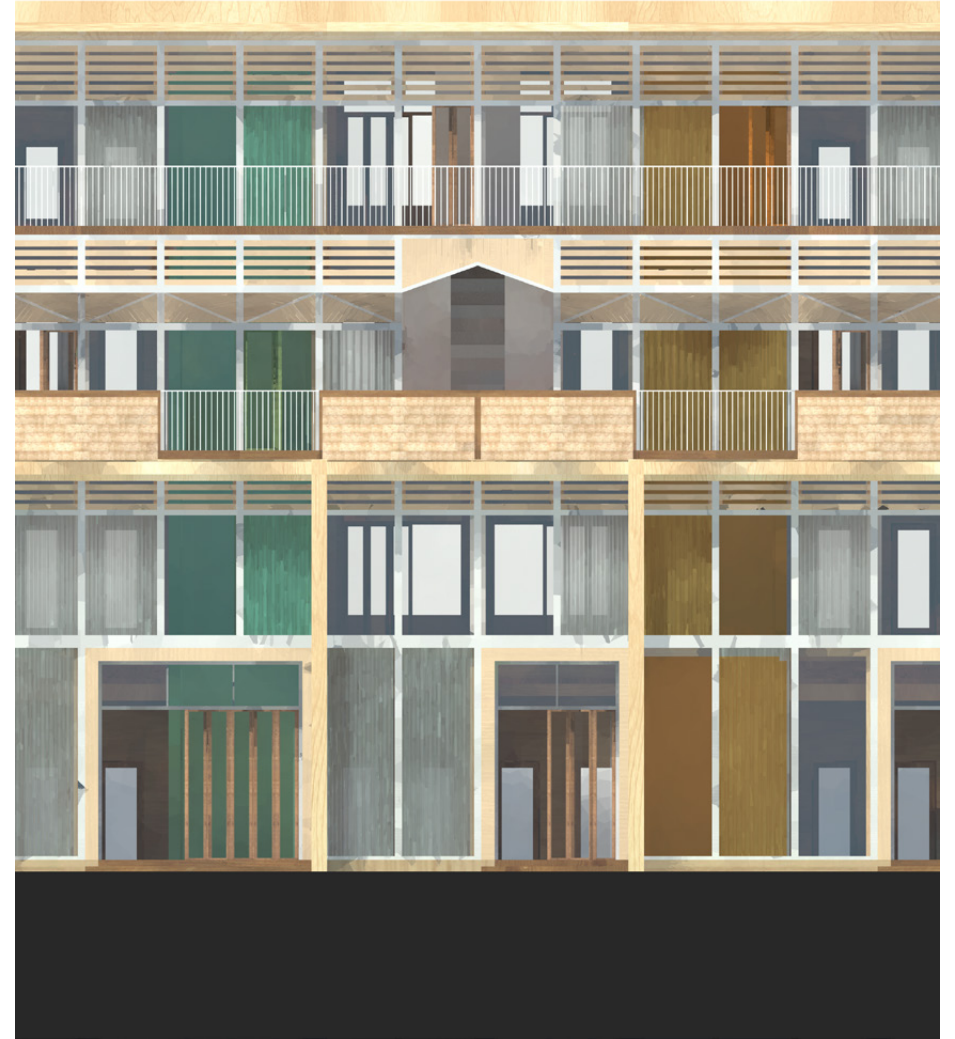

Inner Facade

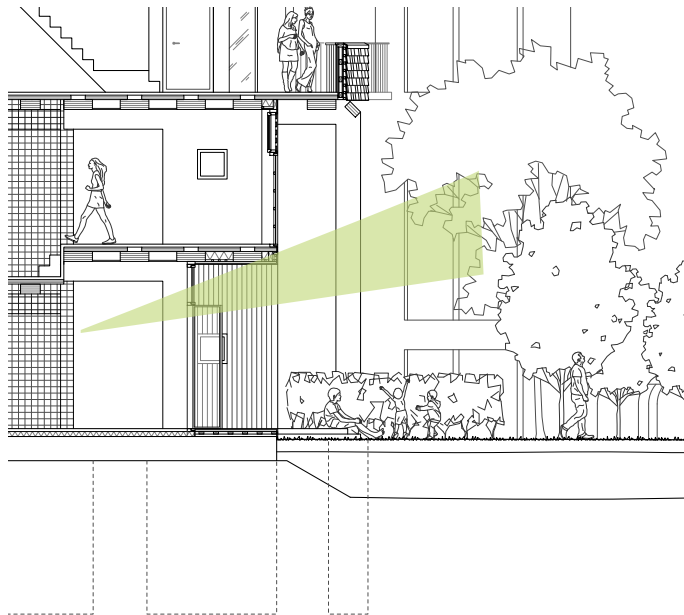
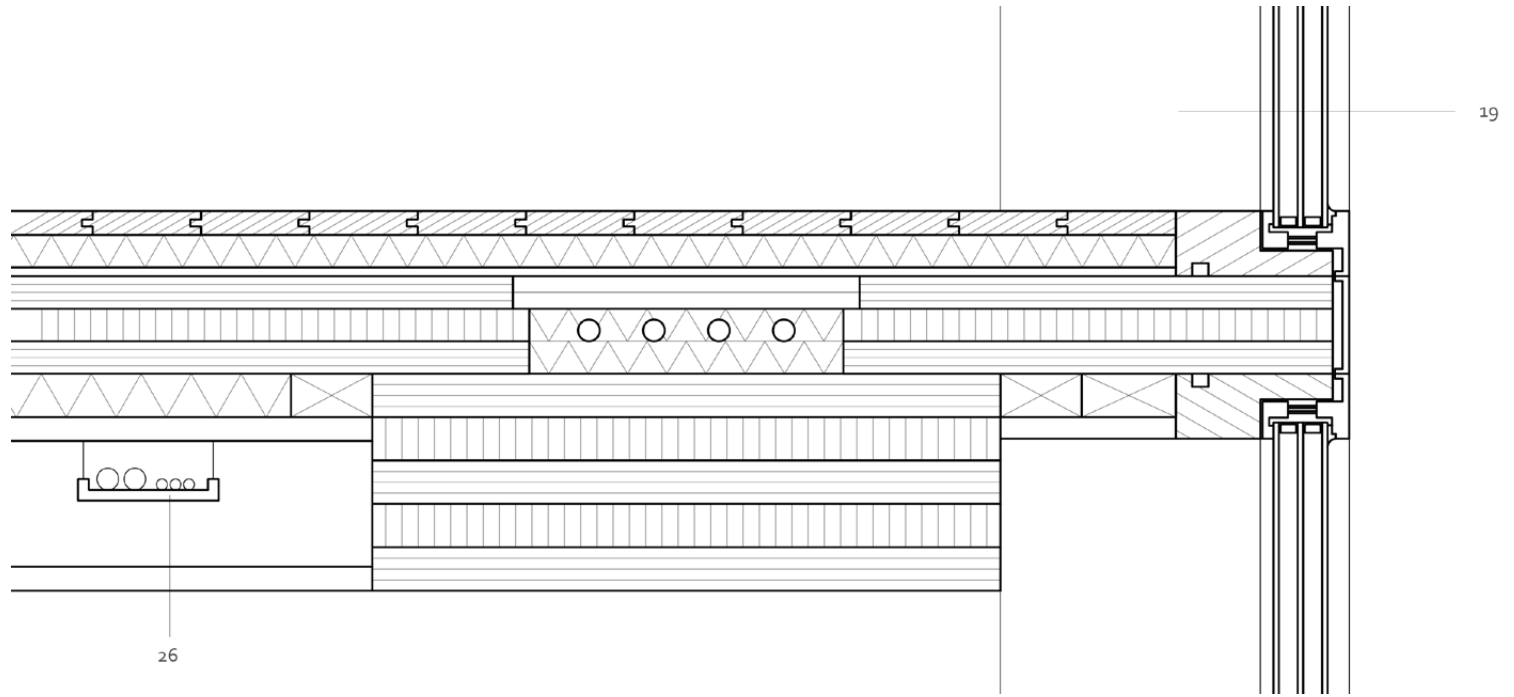

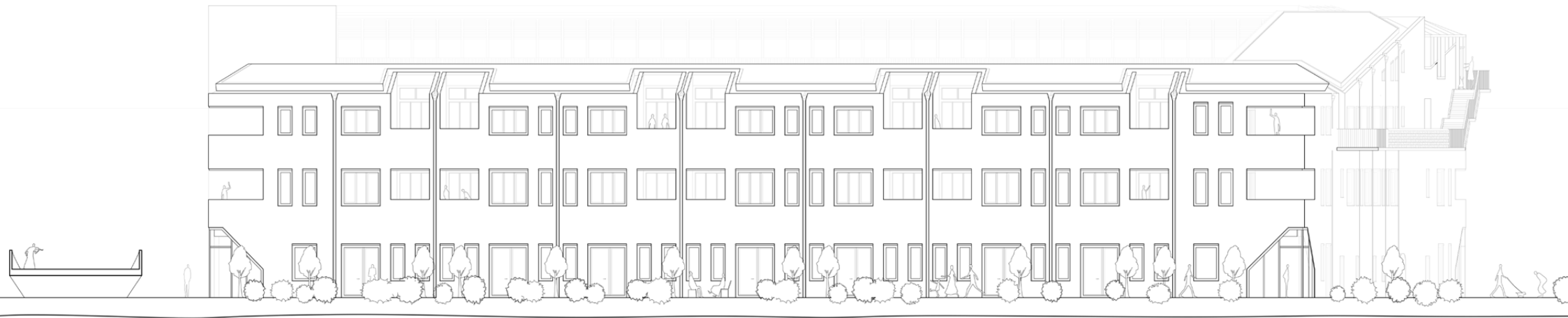

Elevation South

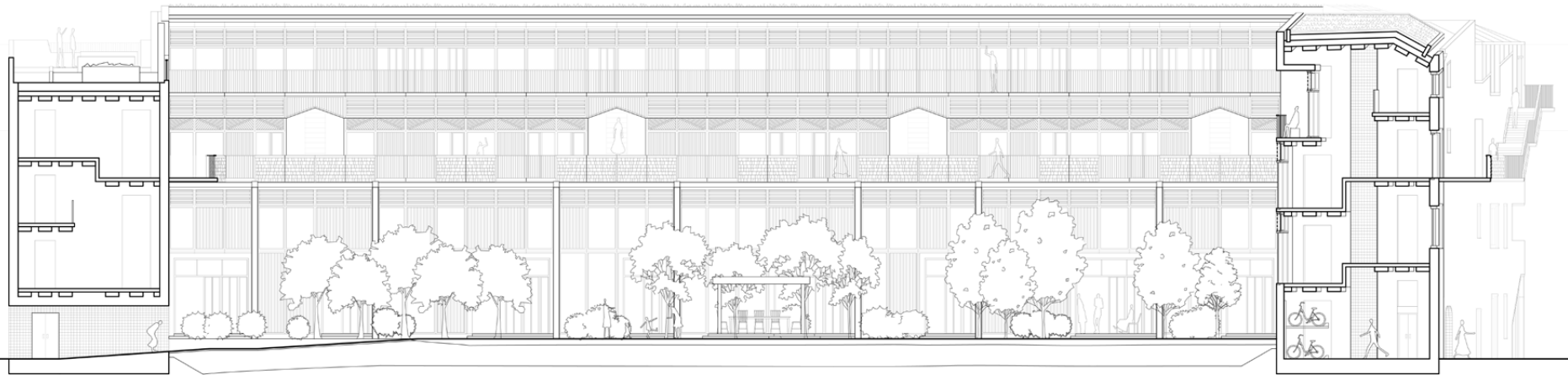

Section West-to-East



Section West-to-East



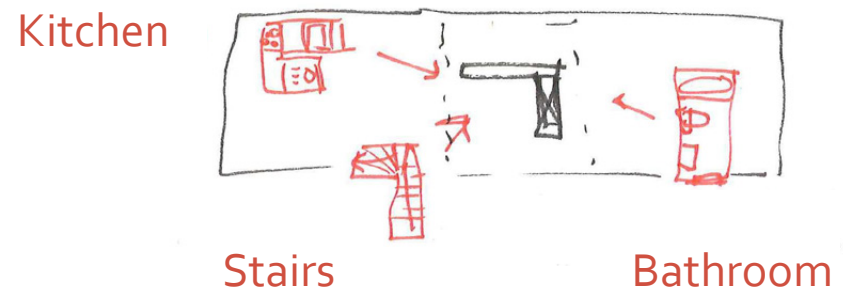
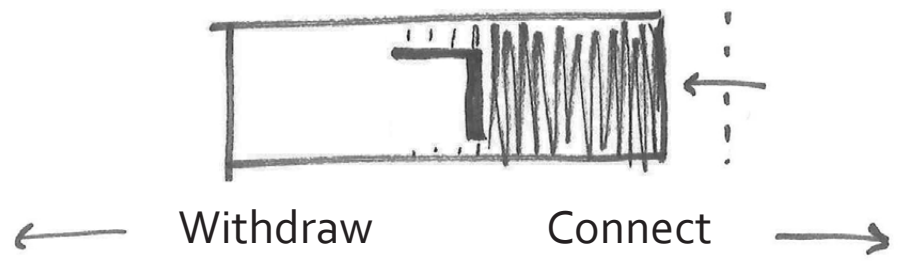
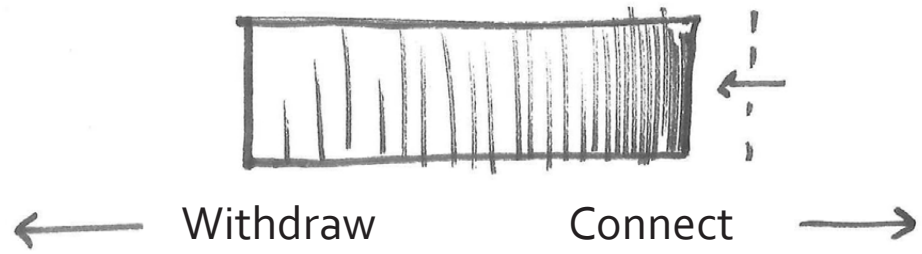

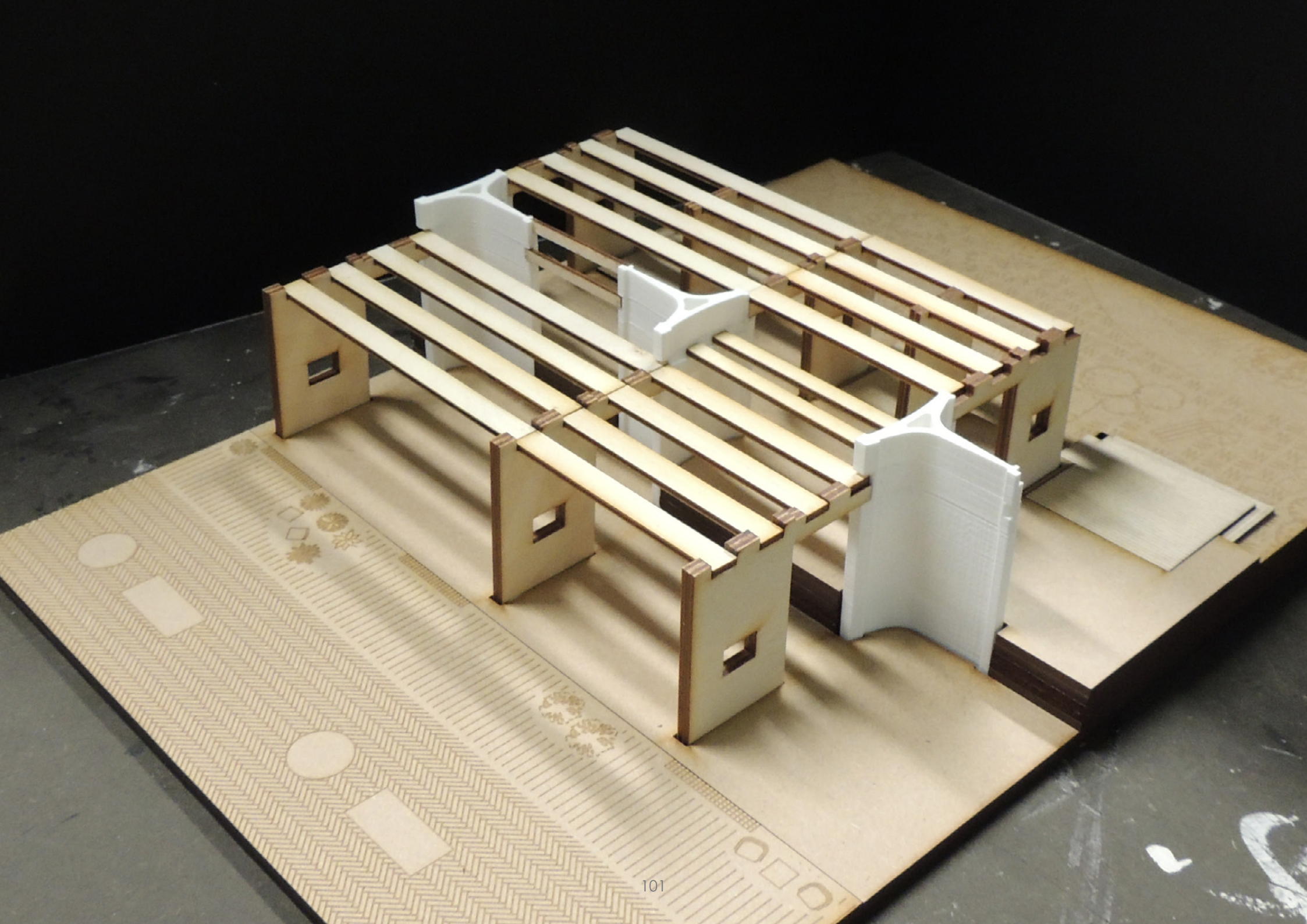

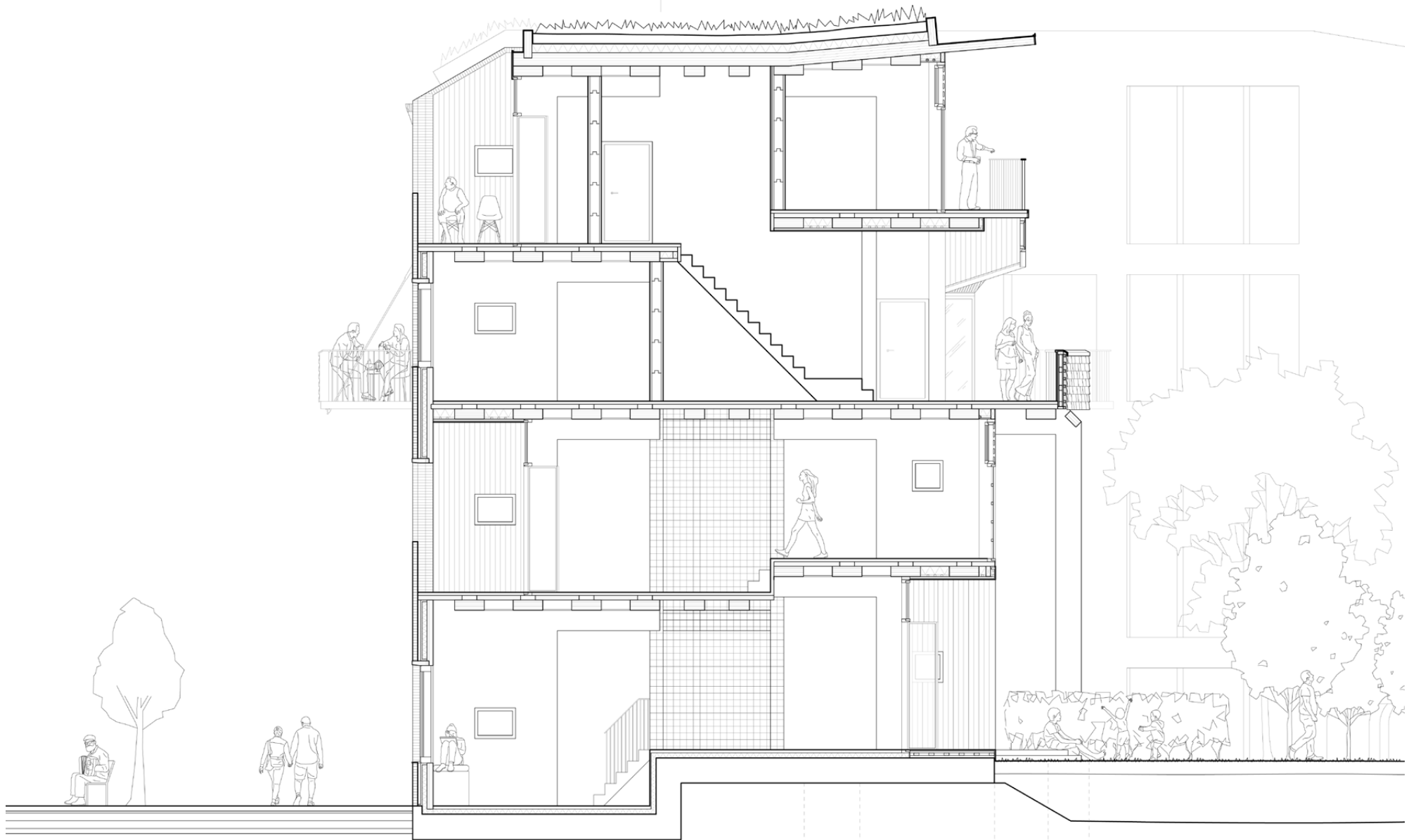

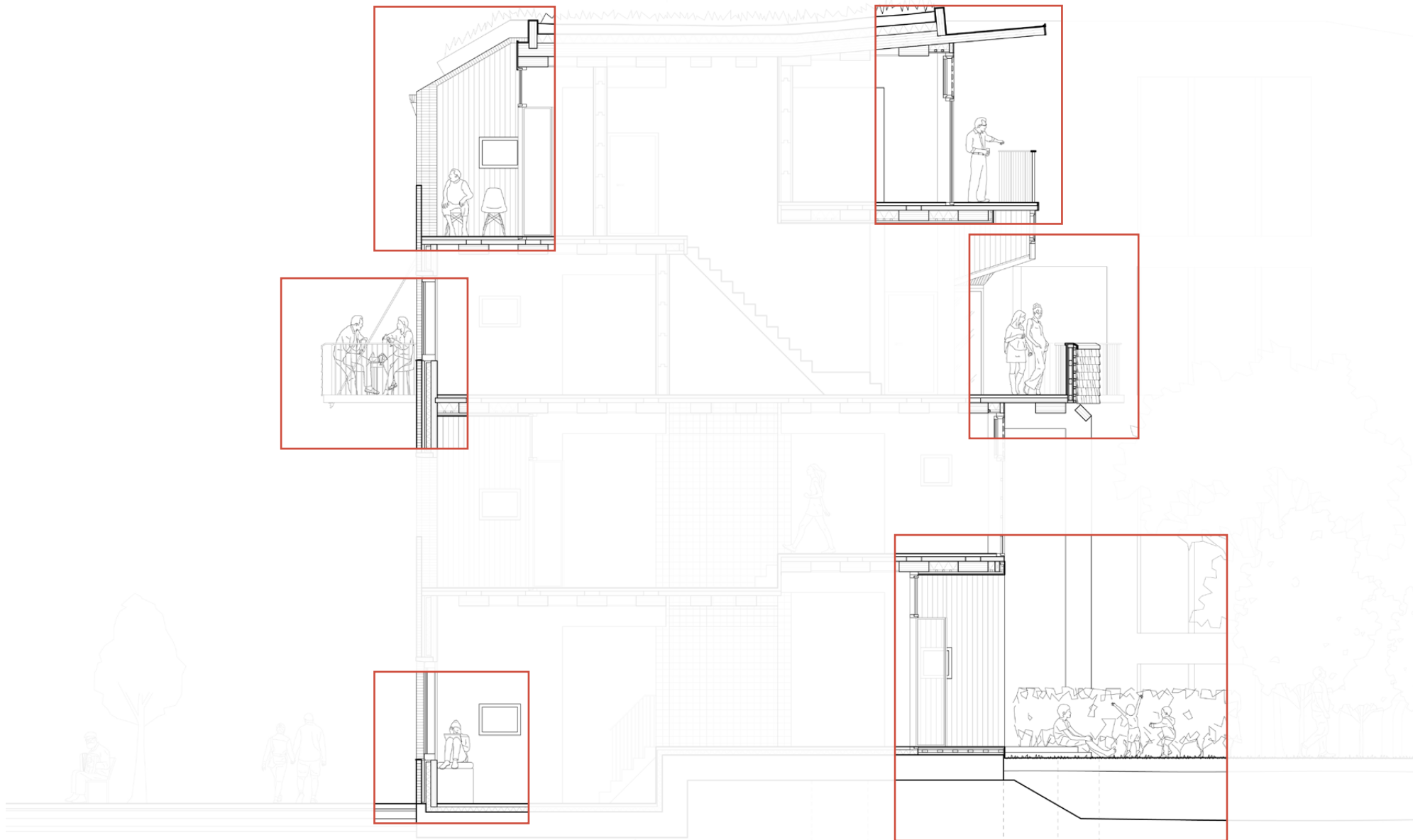



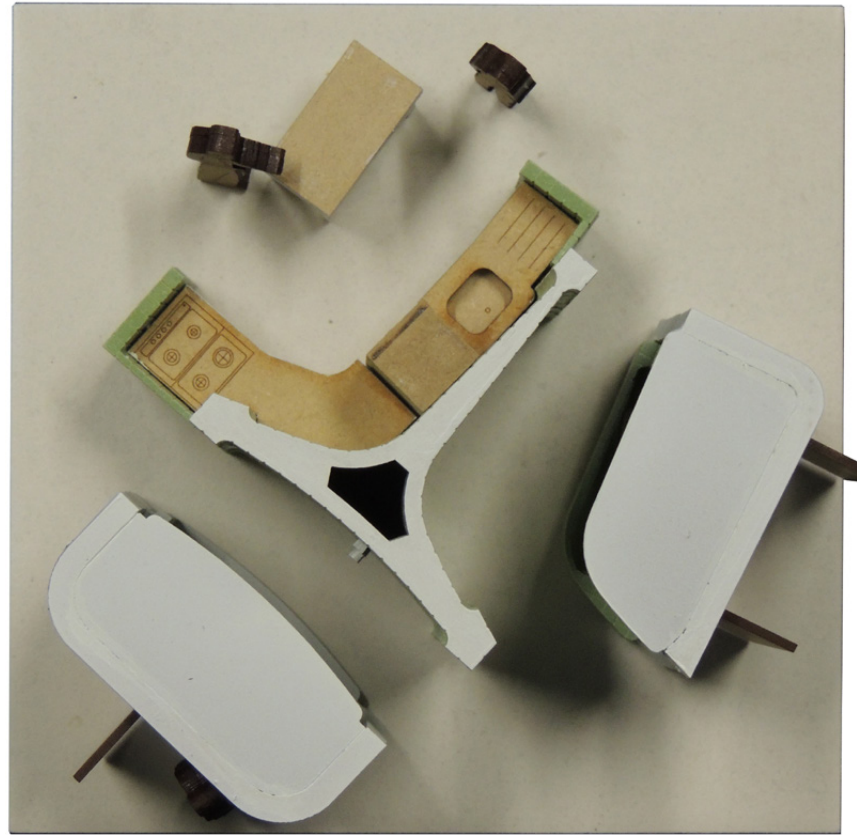
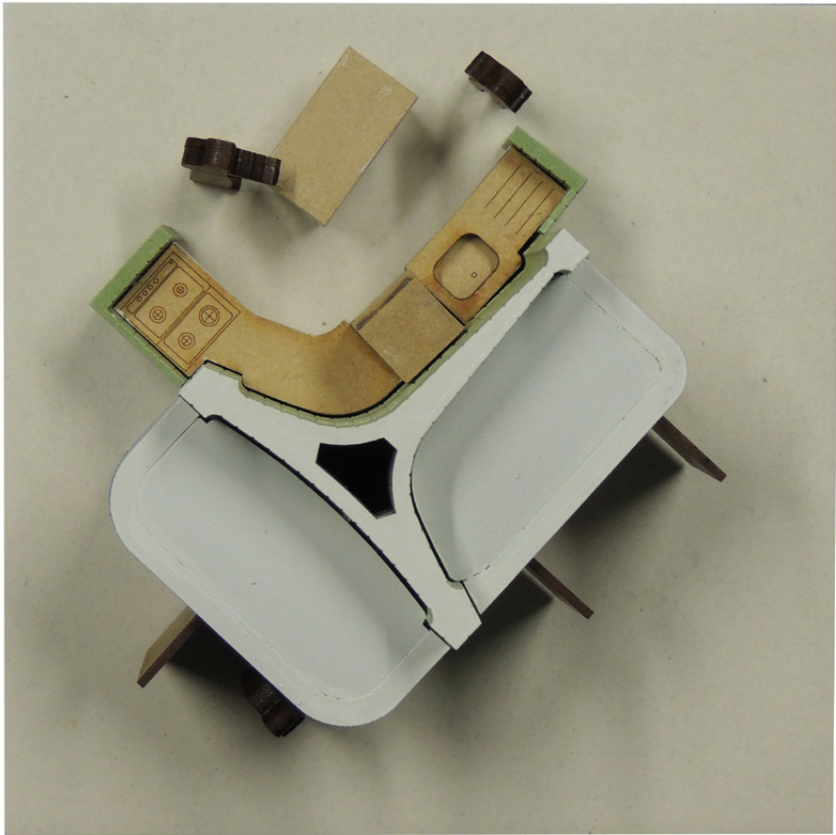

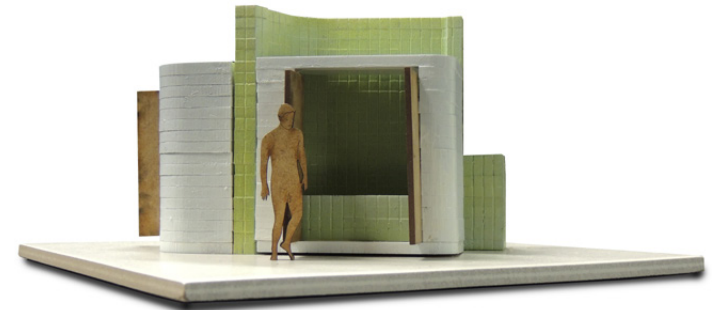
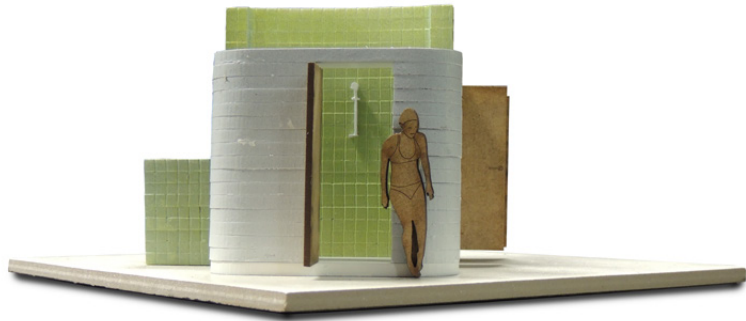



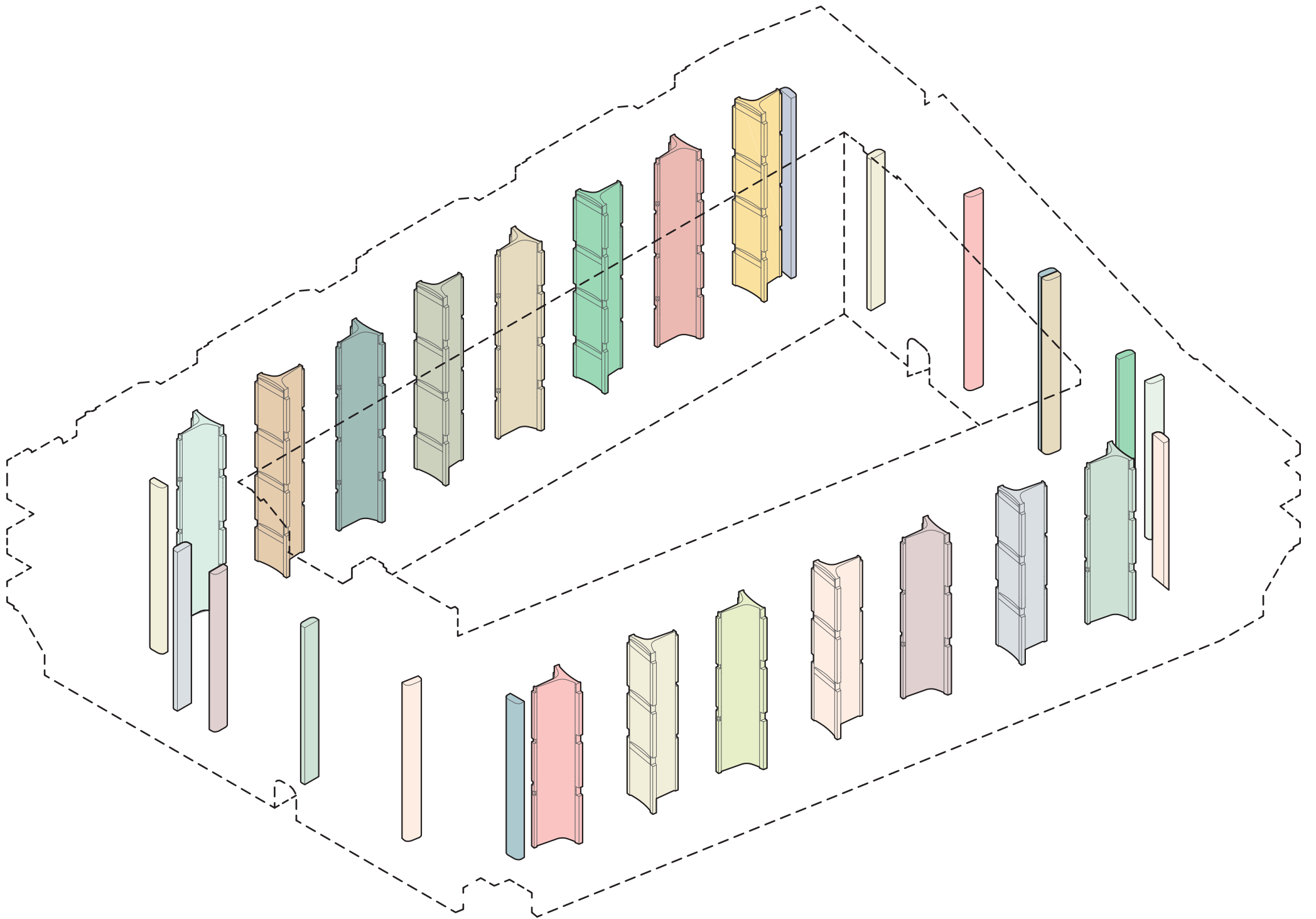

Stories from Eindhoven

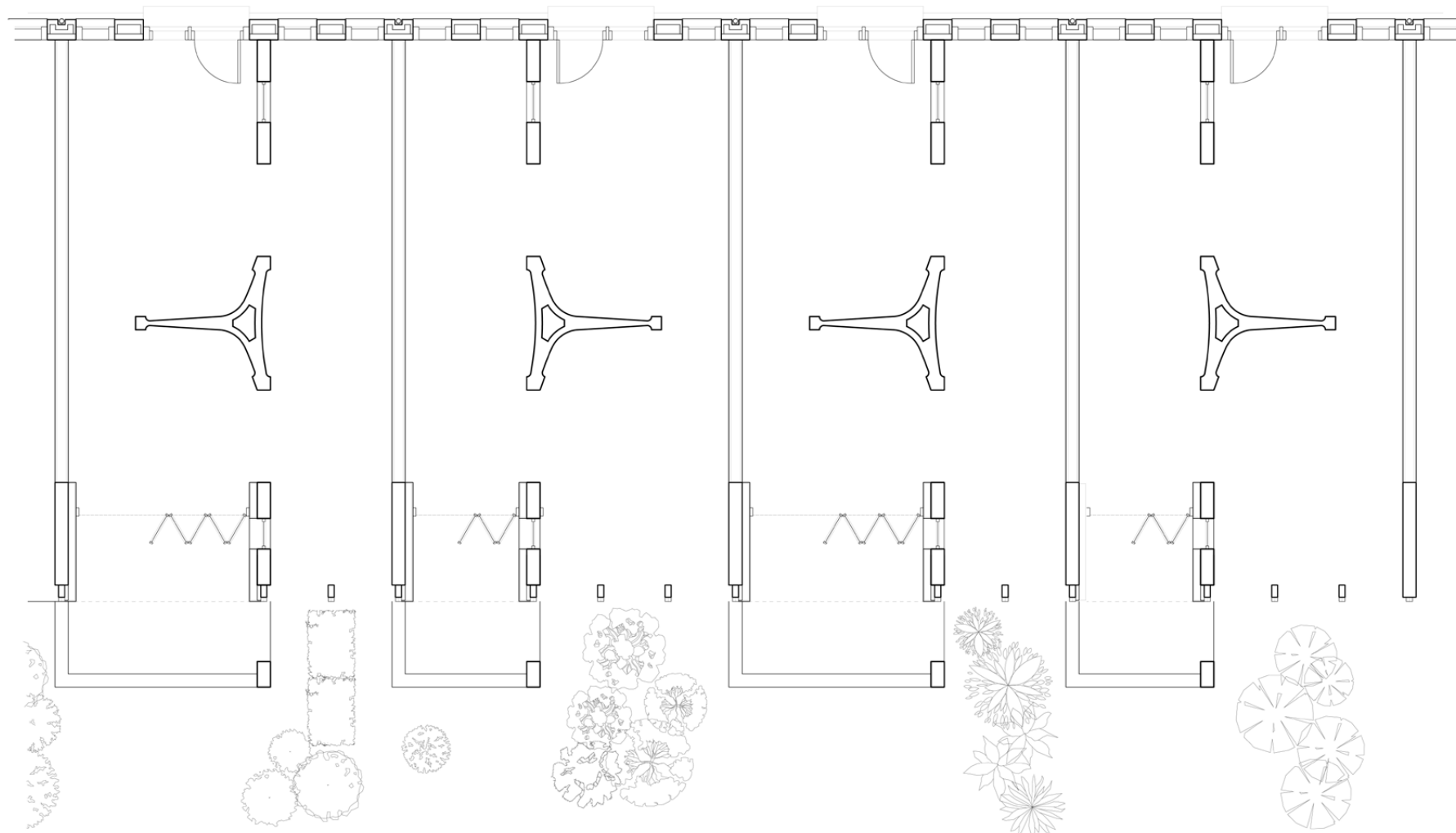

Floor 00

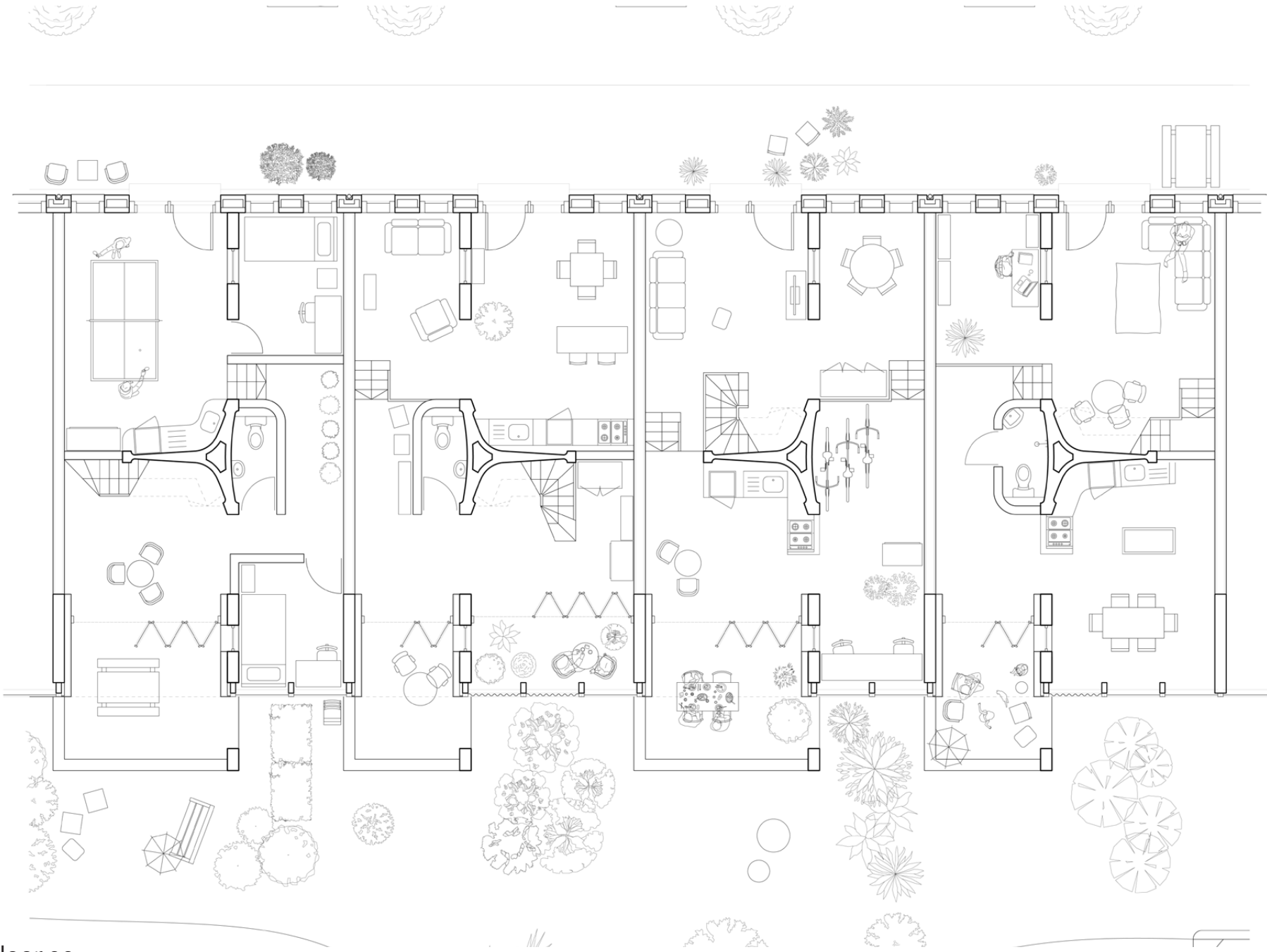

Floor 00

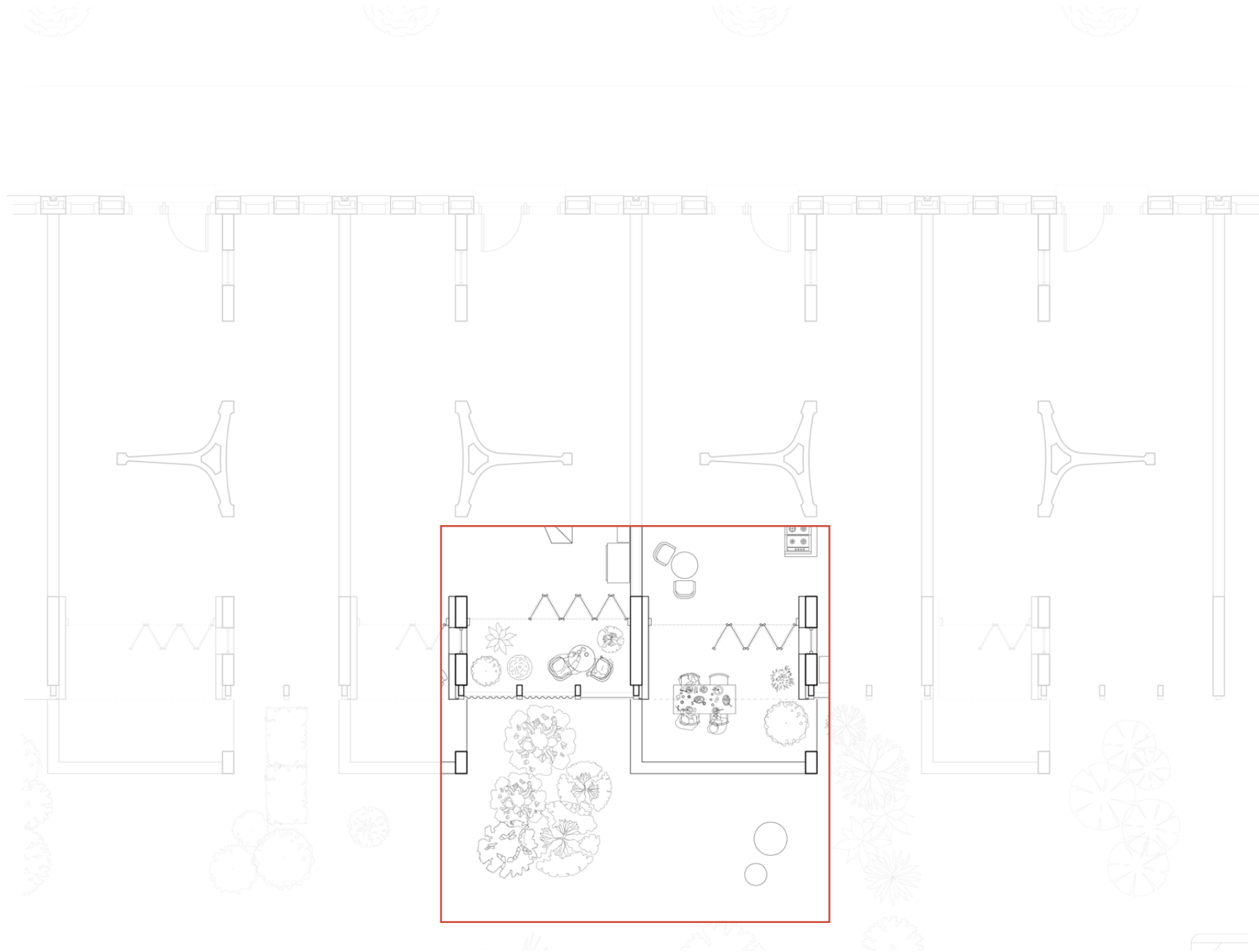

Floor 00





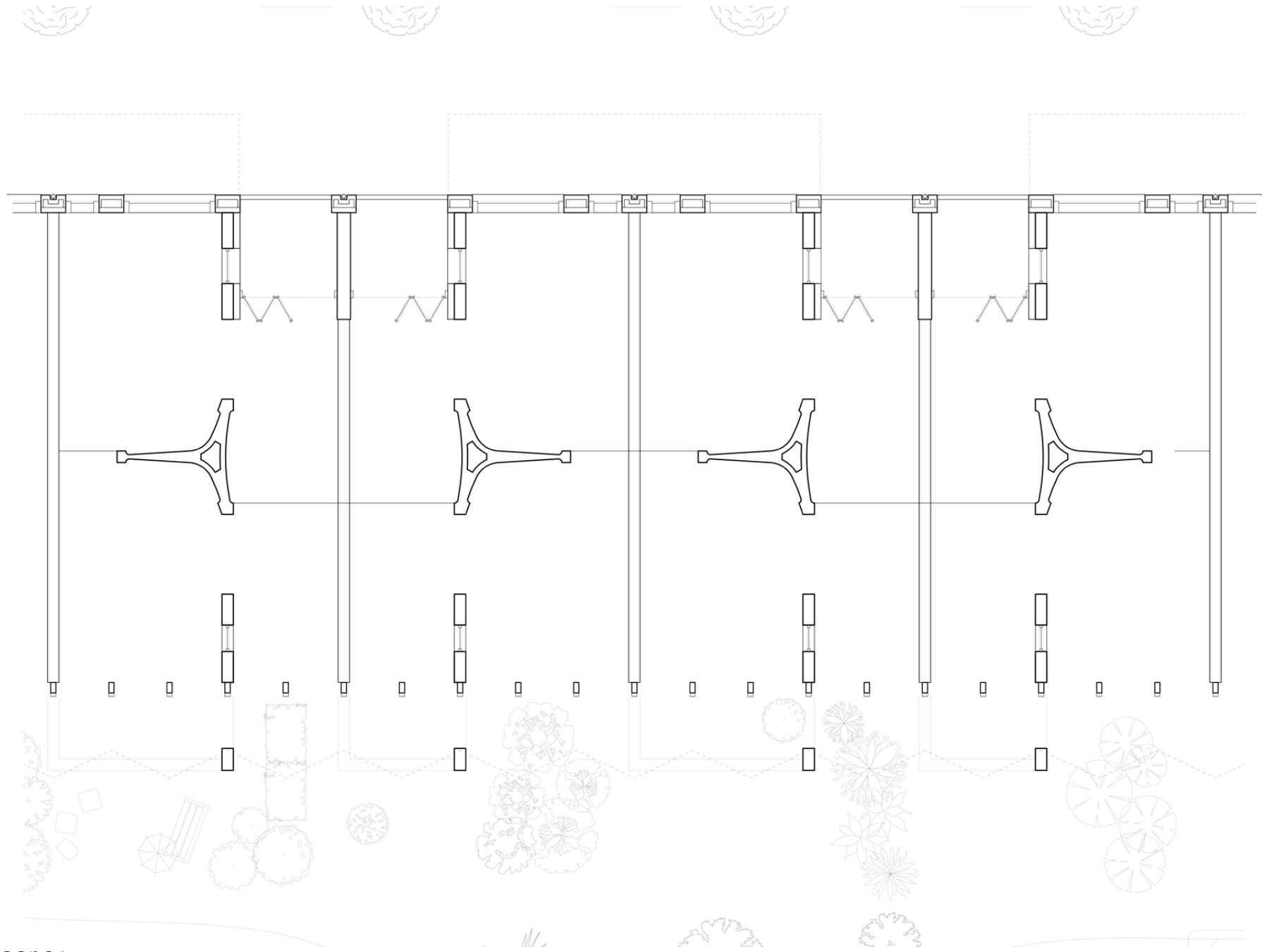

Floor 01

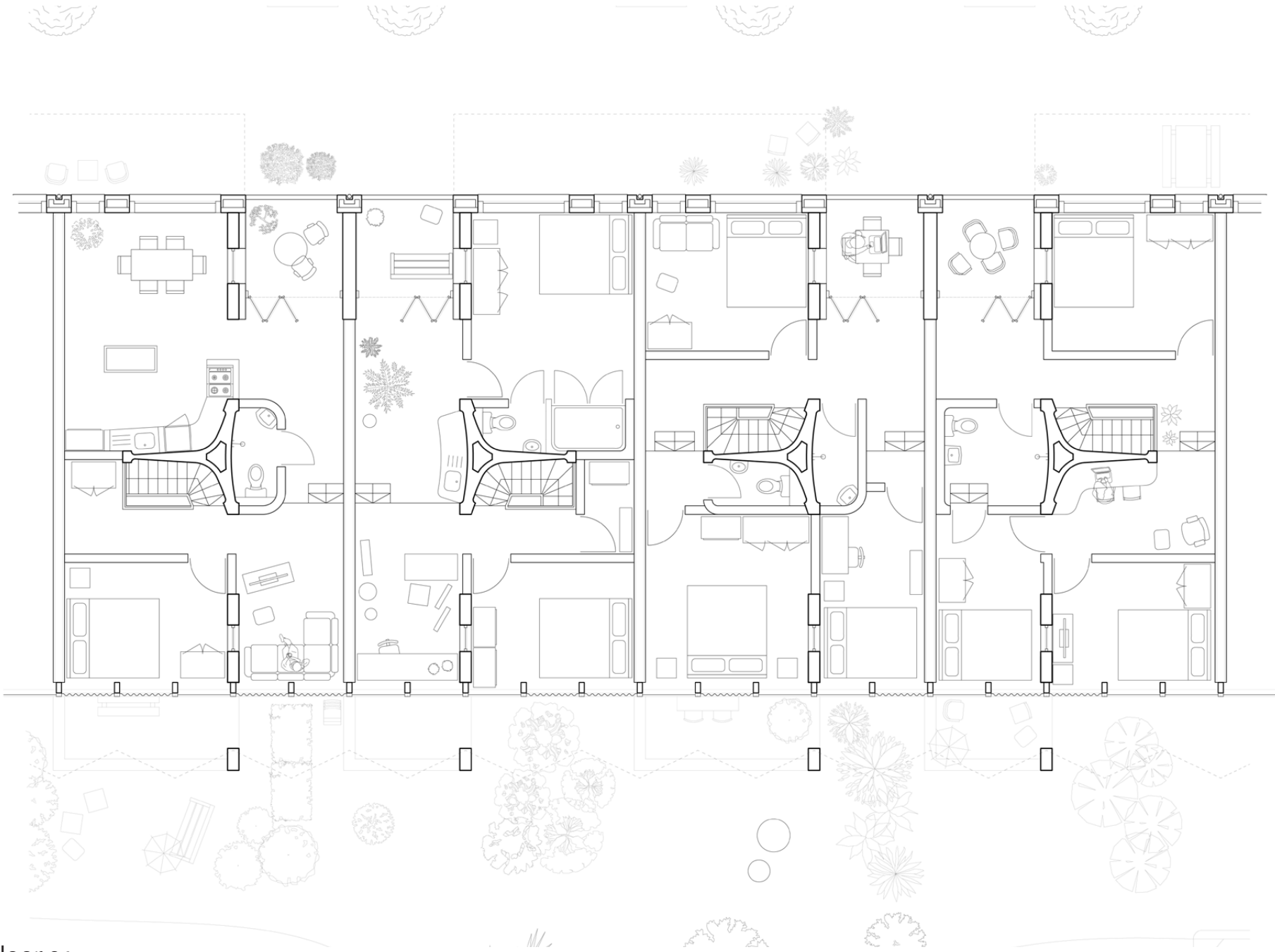

Floor 01

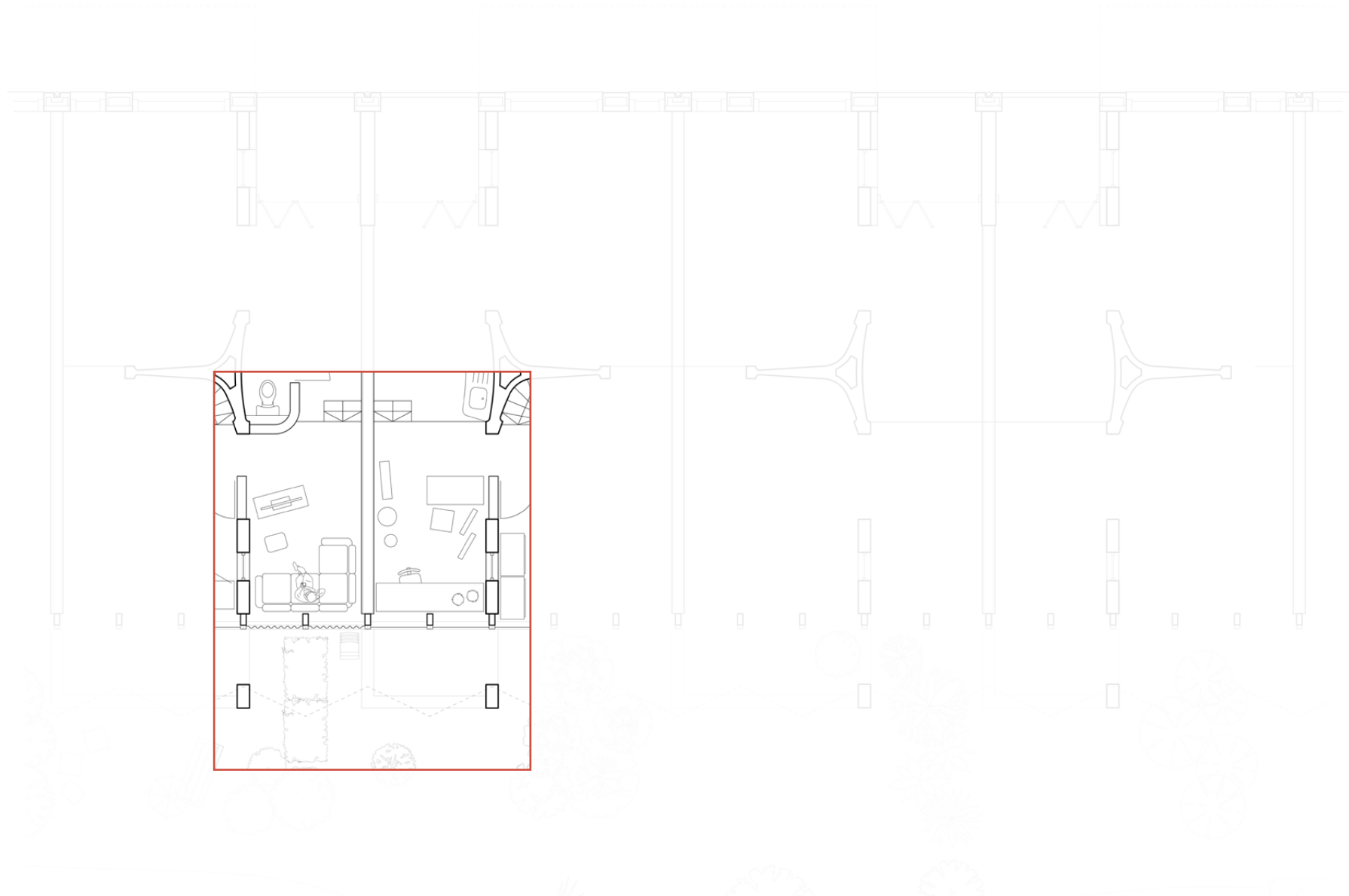

Floor 01





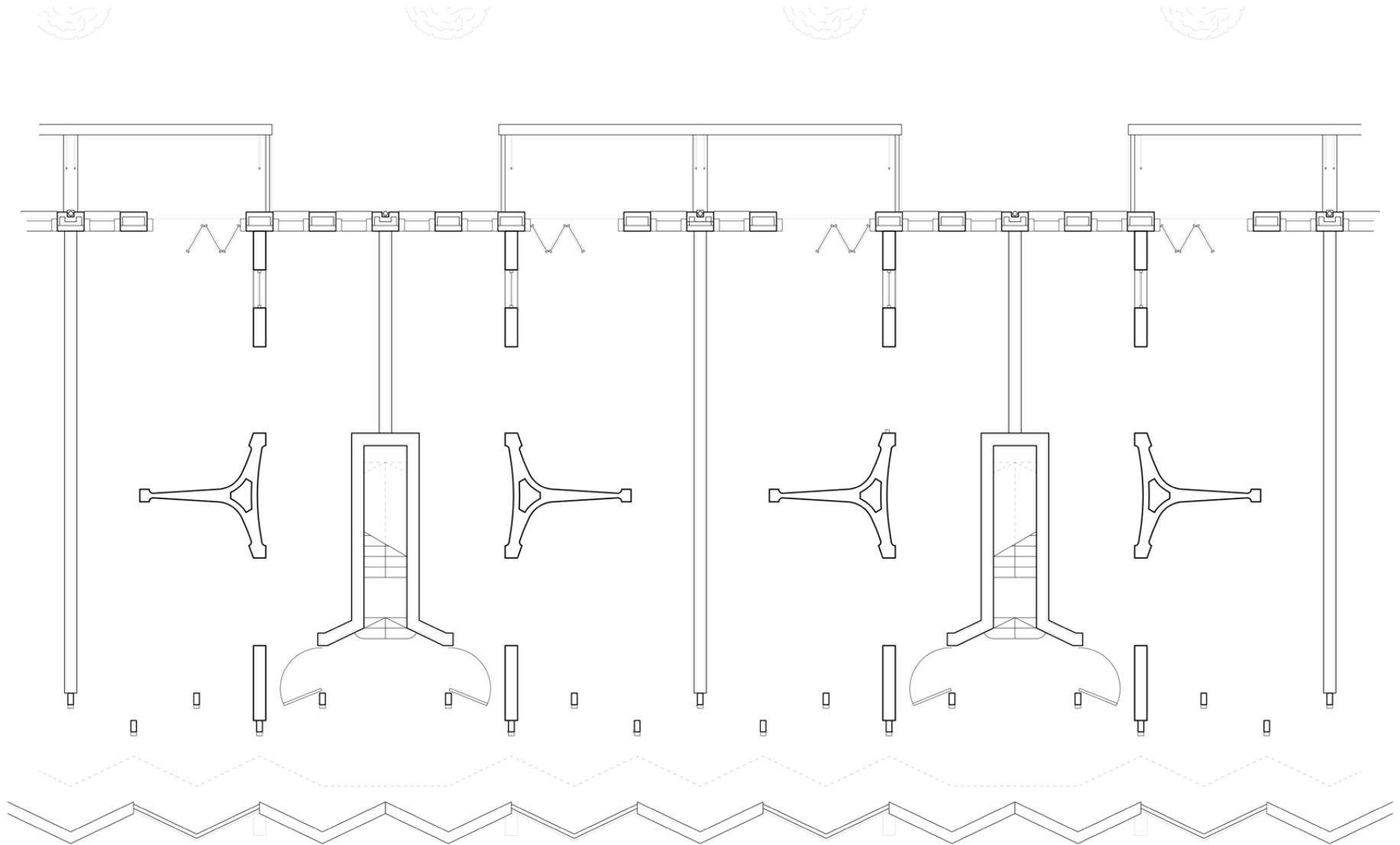

Floor 02

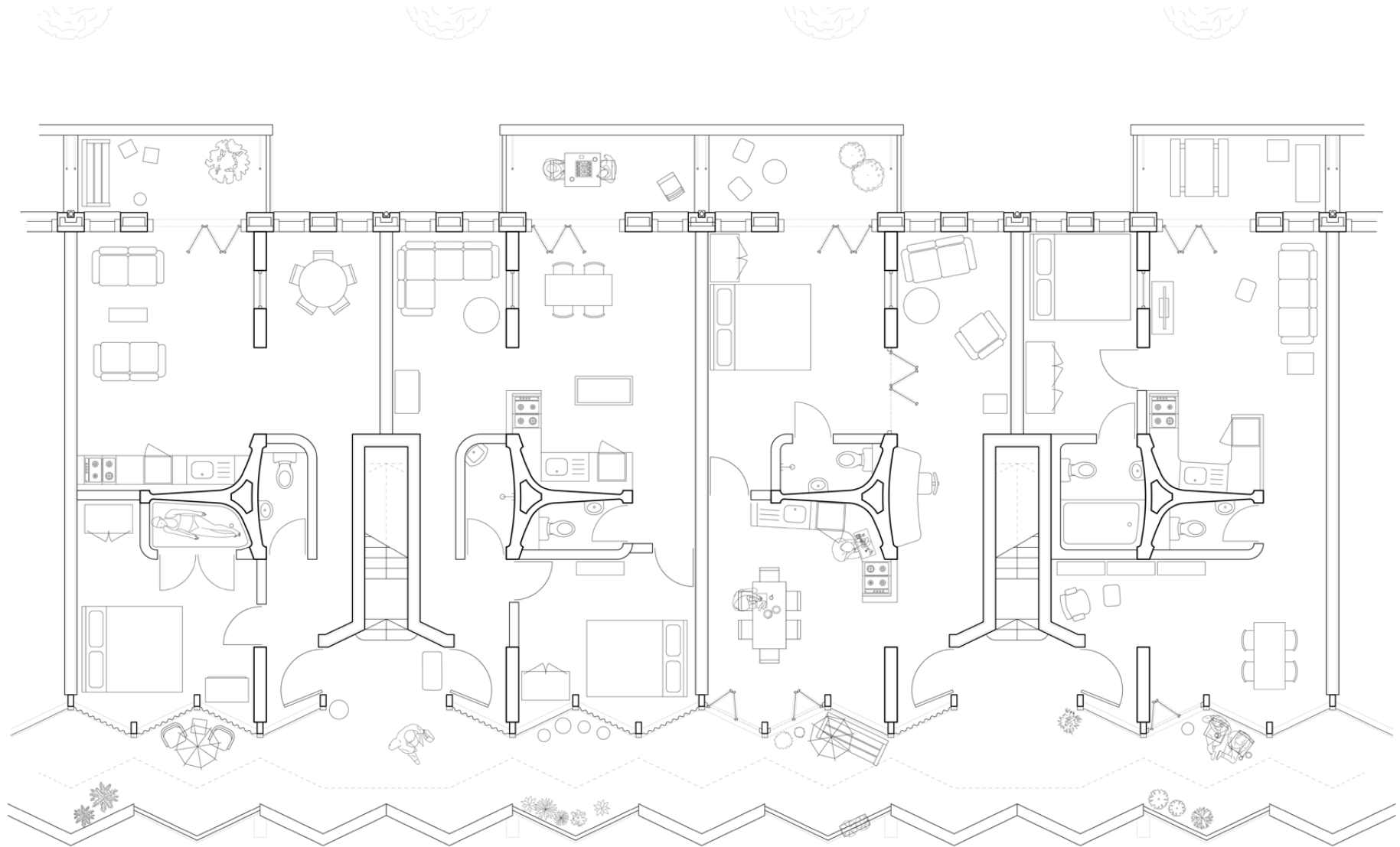

Floor 02

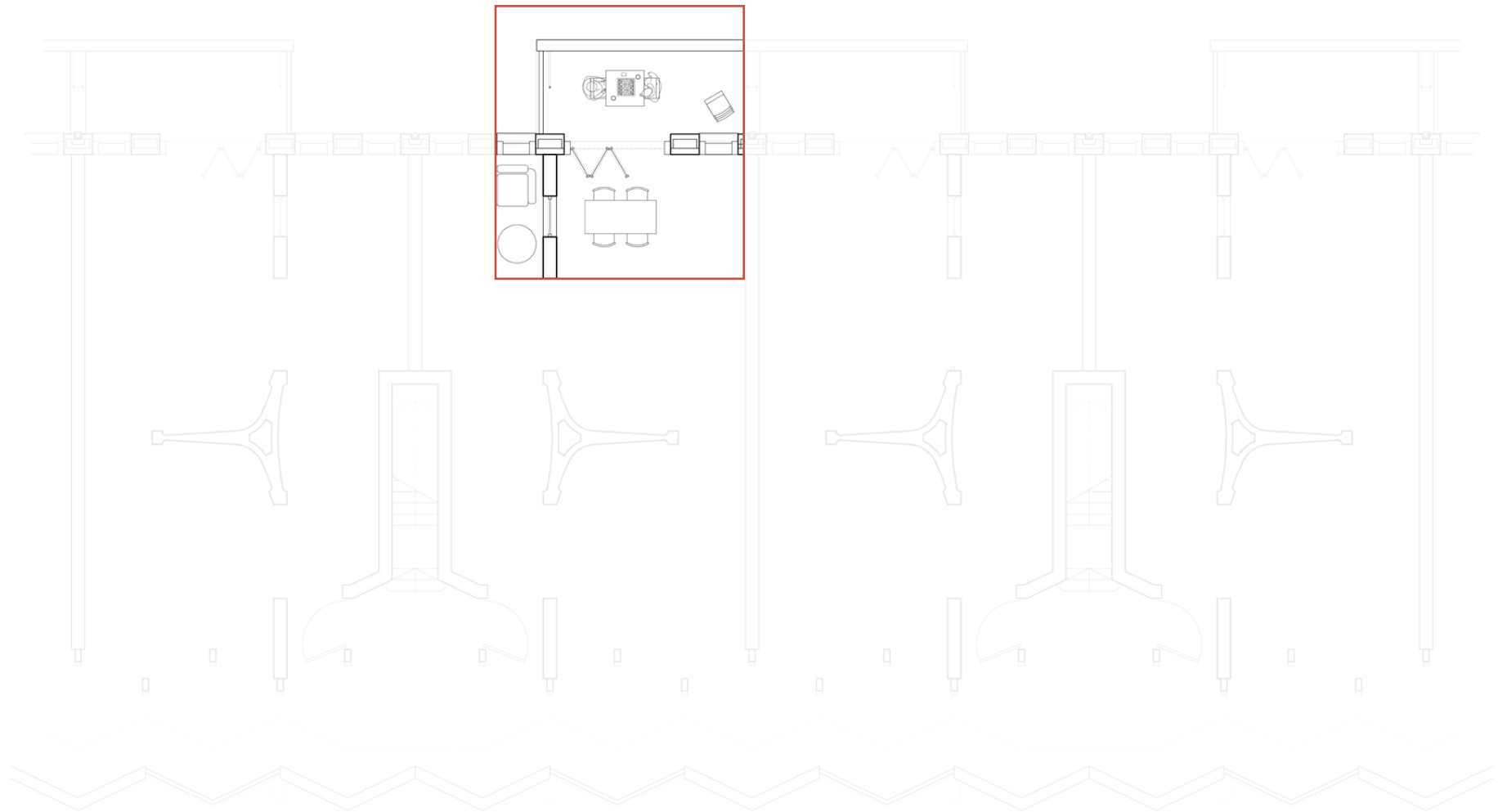

Floor 02





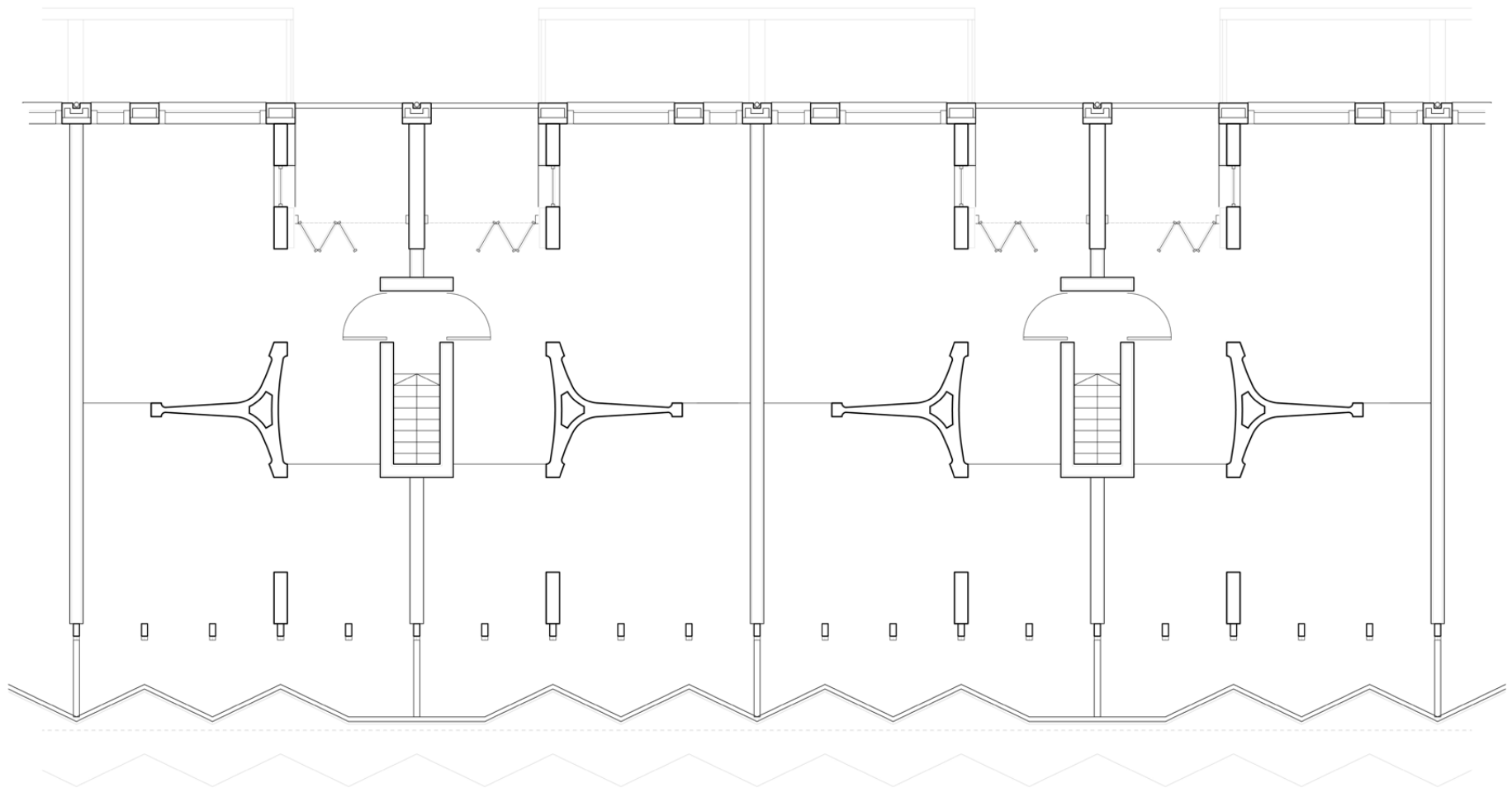

Floor 03

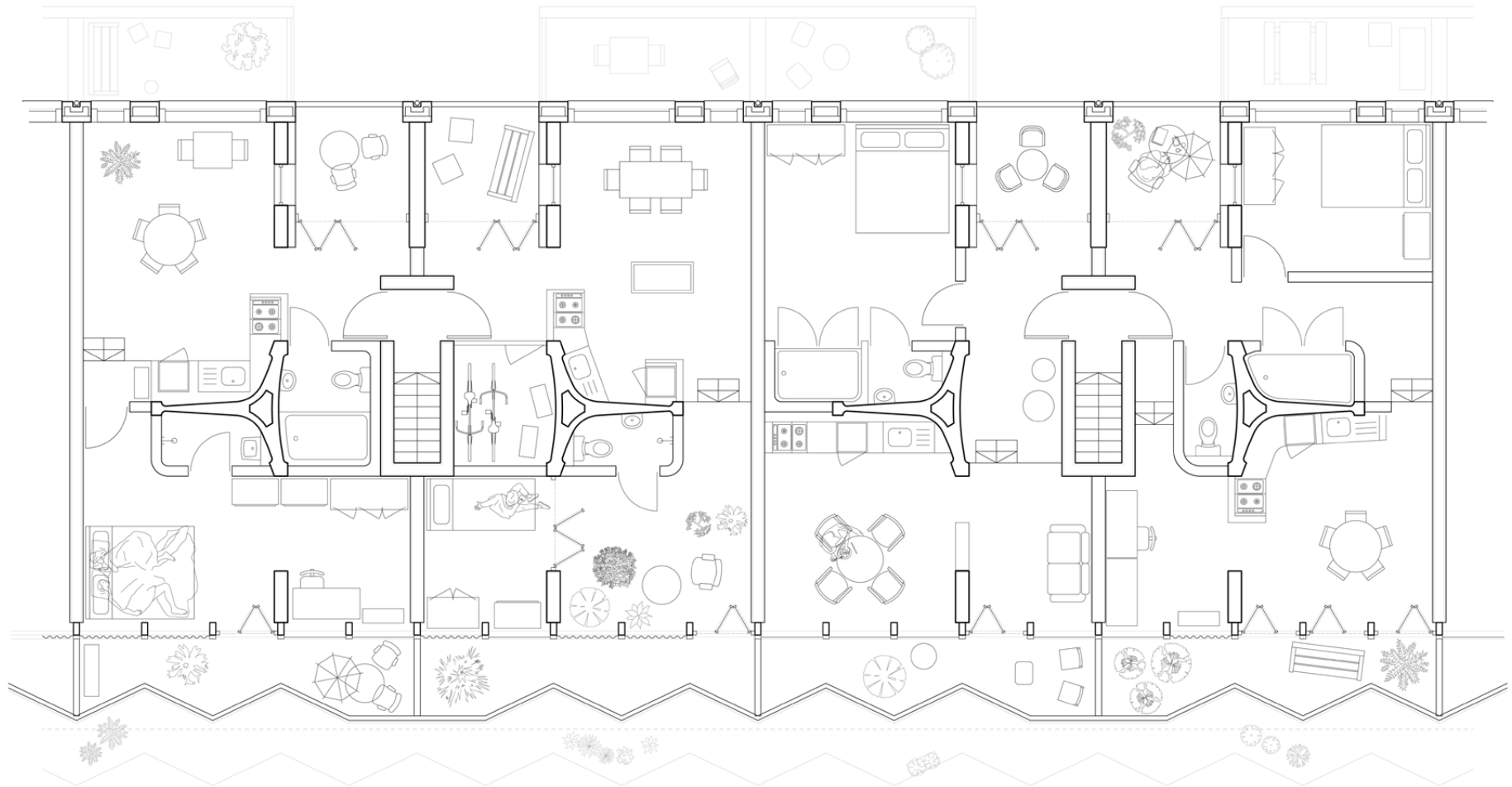

Floor 03

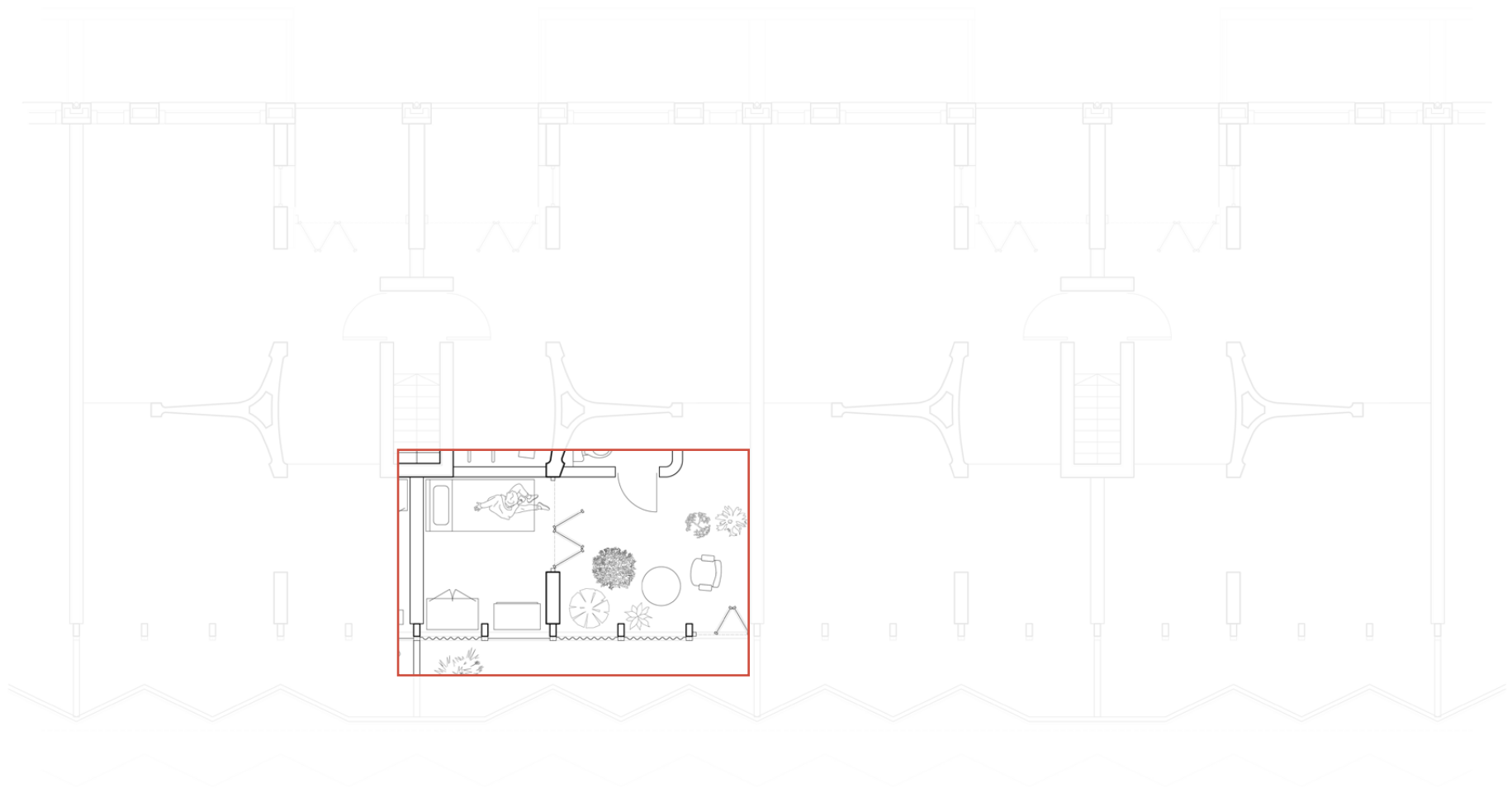

Floor 03







Summary

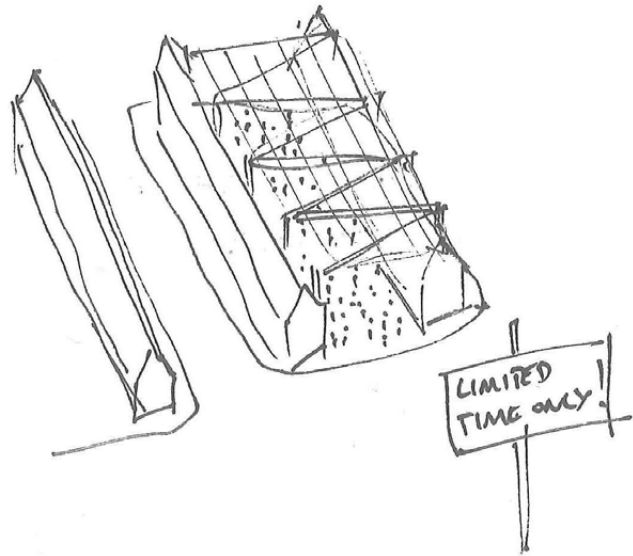

P1

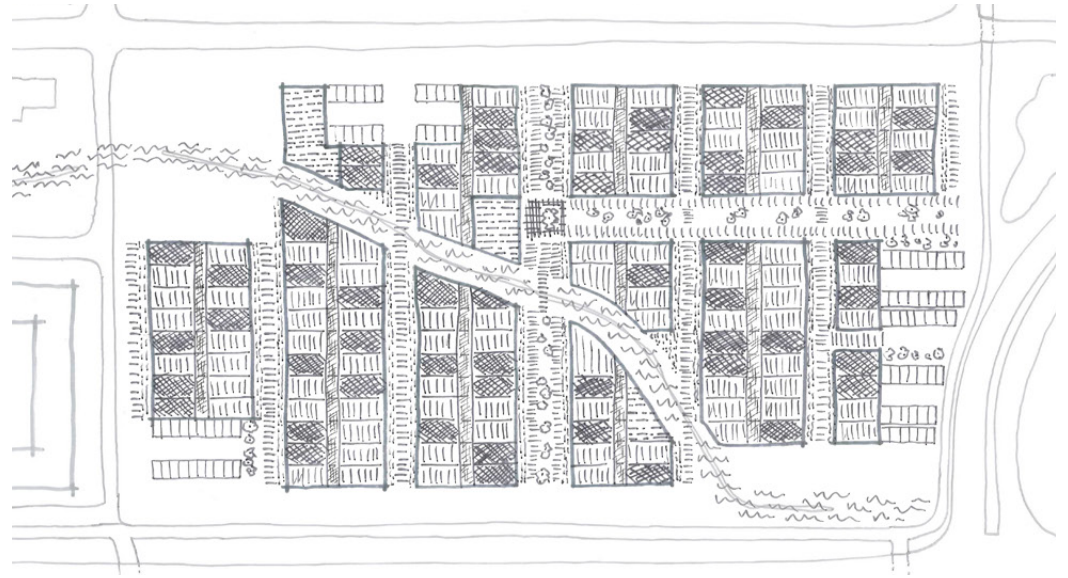

P2

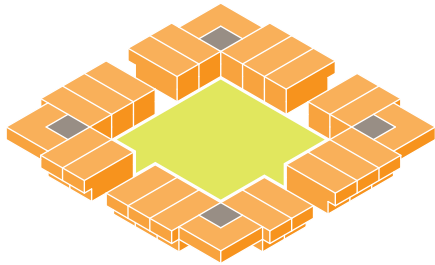
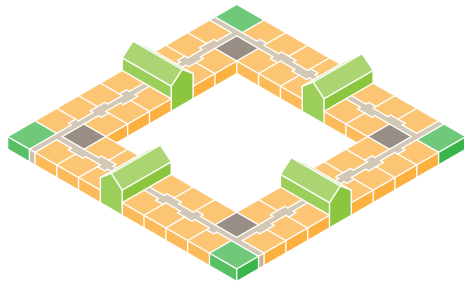

P3

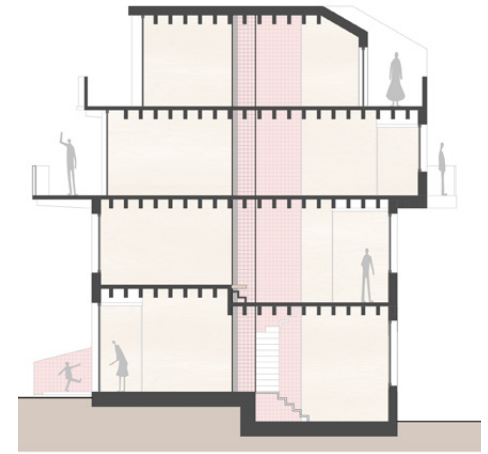
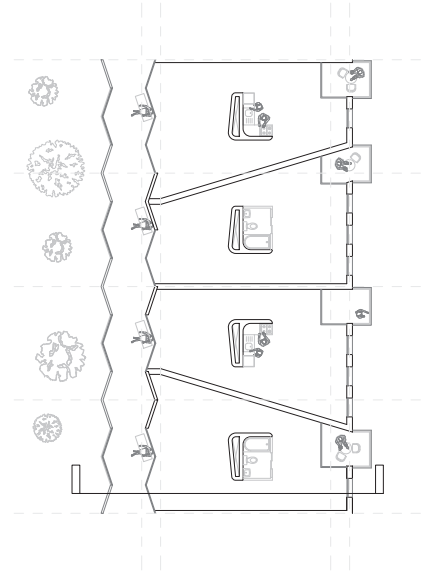

P4

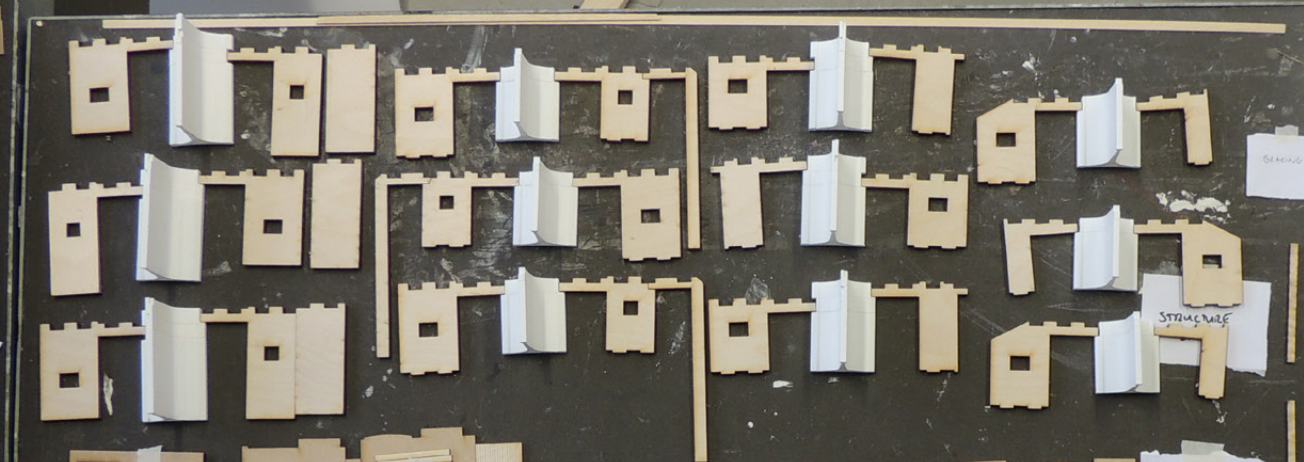

Floor 00

Floor 01

Floor 02

Floor 03

SEARCH

LEVEL CHANGE

FLOOR

STRUCTURE

SPACE

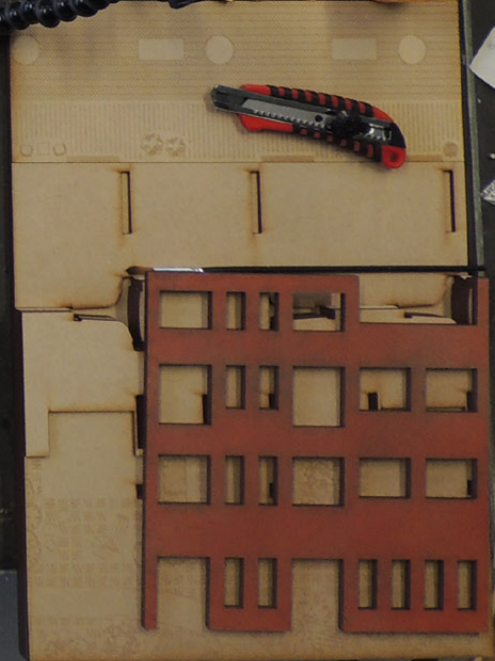

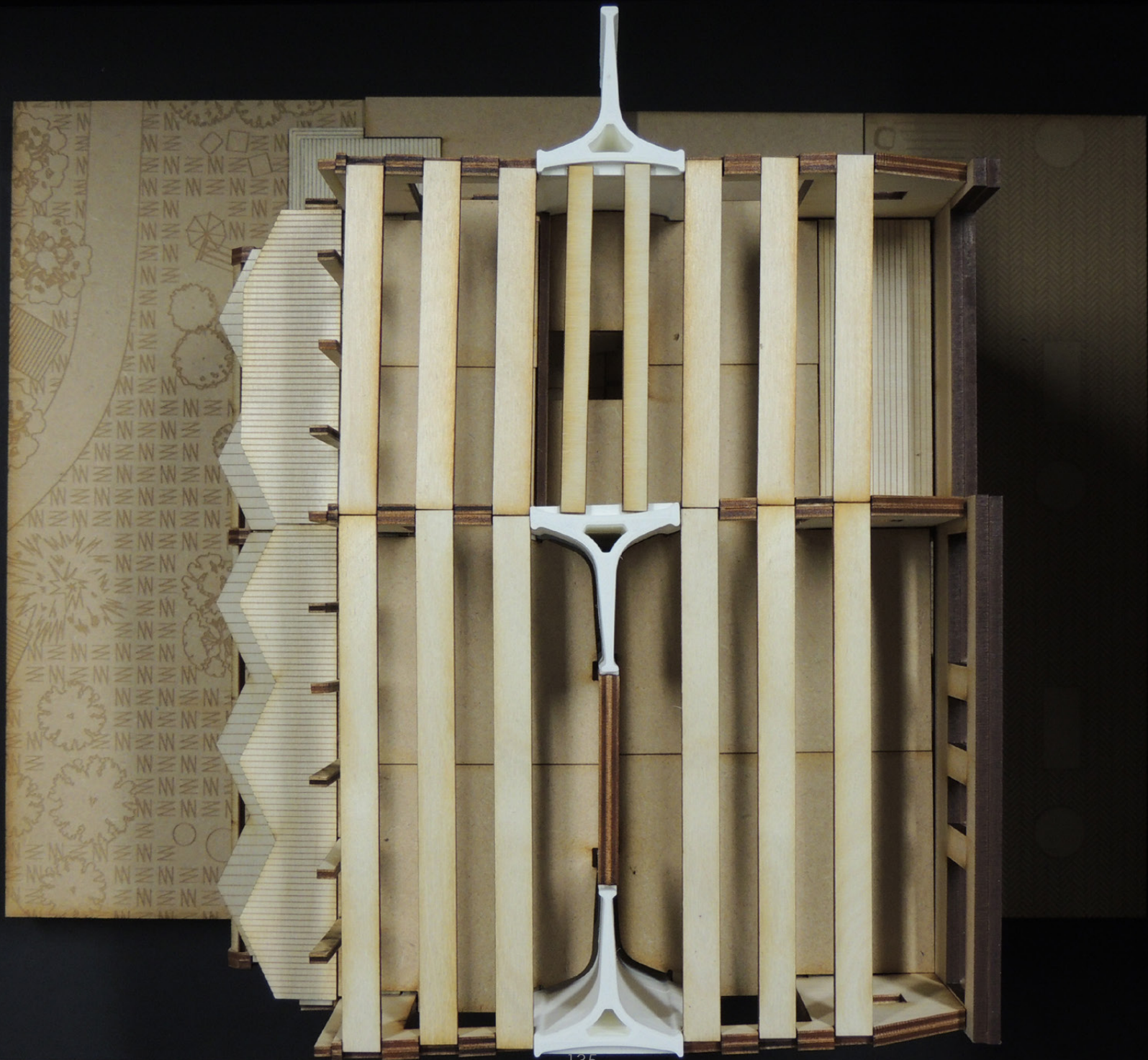



Raumplan



Plan Libre



Raumplan

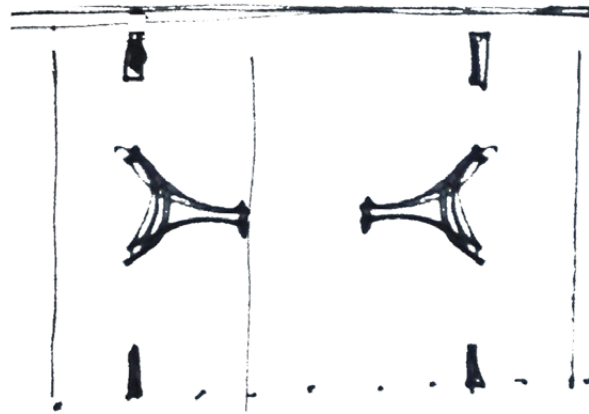

Thesis Outcome



Plan Libre

