

FIRST DESIGN PHASE - 2025 - PARTICIPATORY COMMUNITY

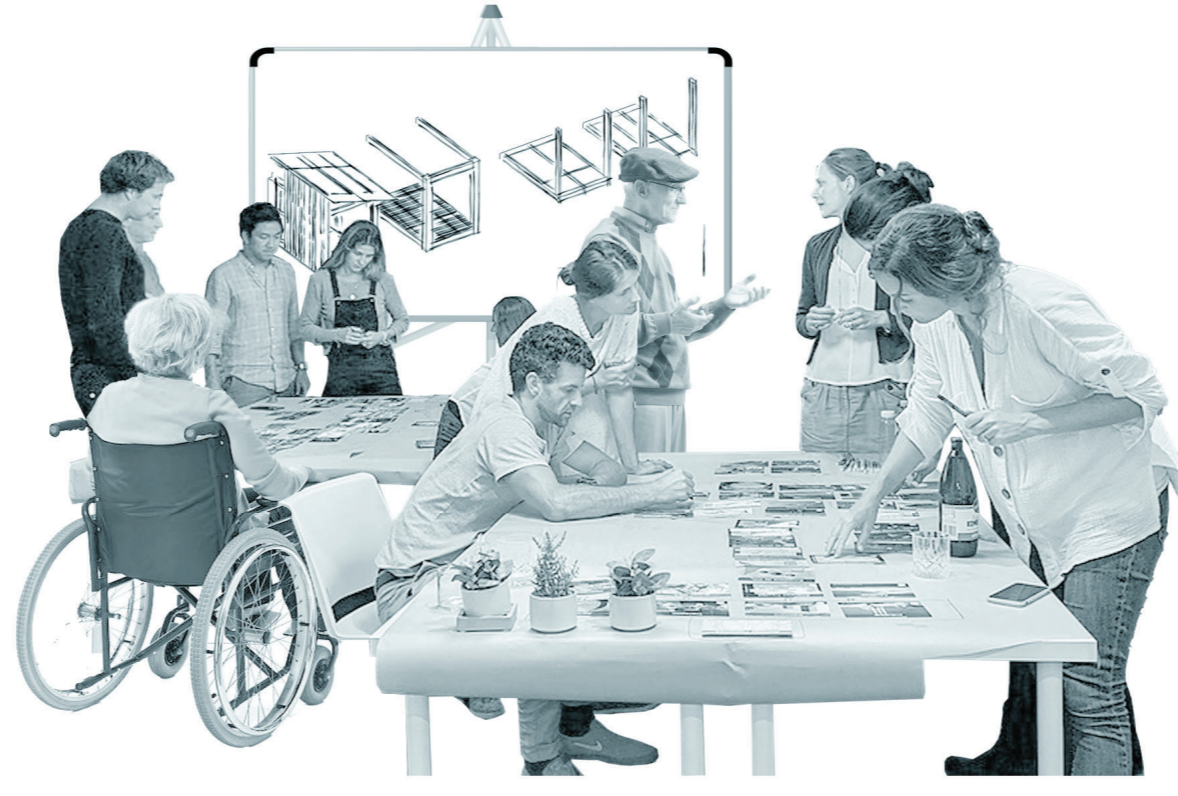

Volunteers, IDPs and Locals collecting waste materials for reuse



Design Workshops and Discussions with IDPs and Local Community



Encouraging and Community Participation in Construction

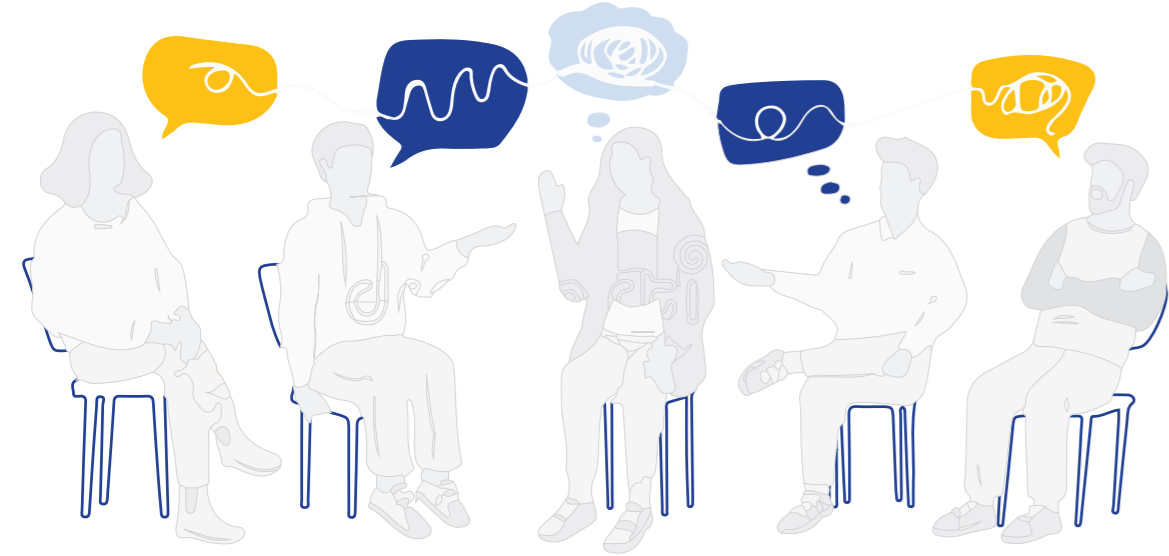

Community Involvement Process Breakdown



Site Plan First Design Stage - Small Modules - Basic Functions - 1:100

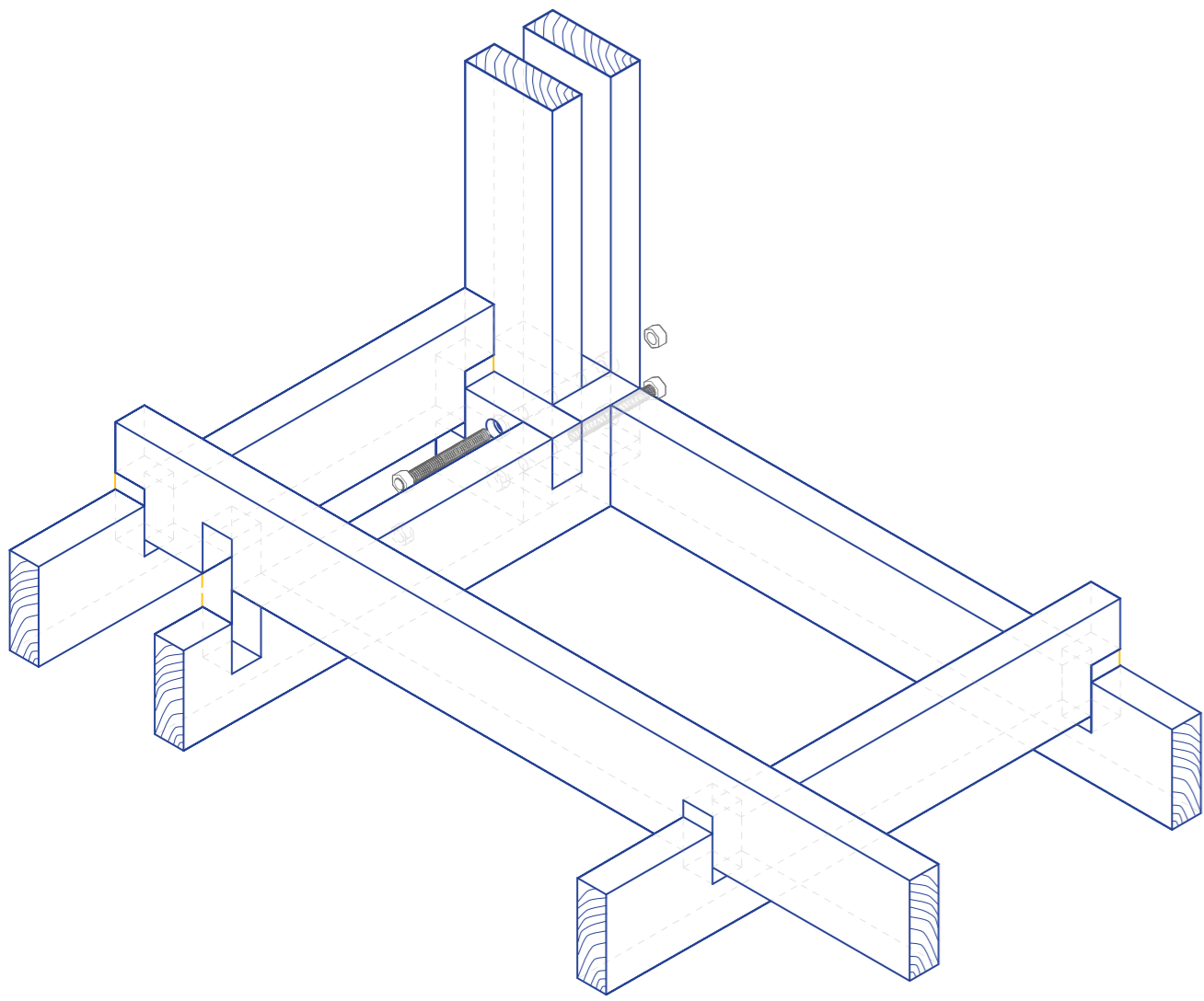

Bottom Corner Structure Detail 1:10

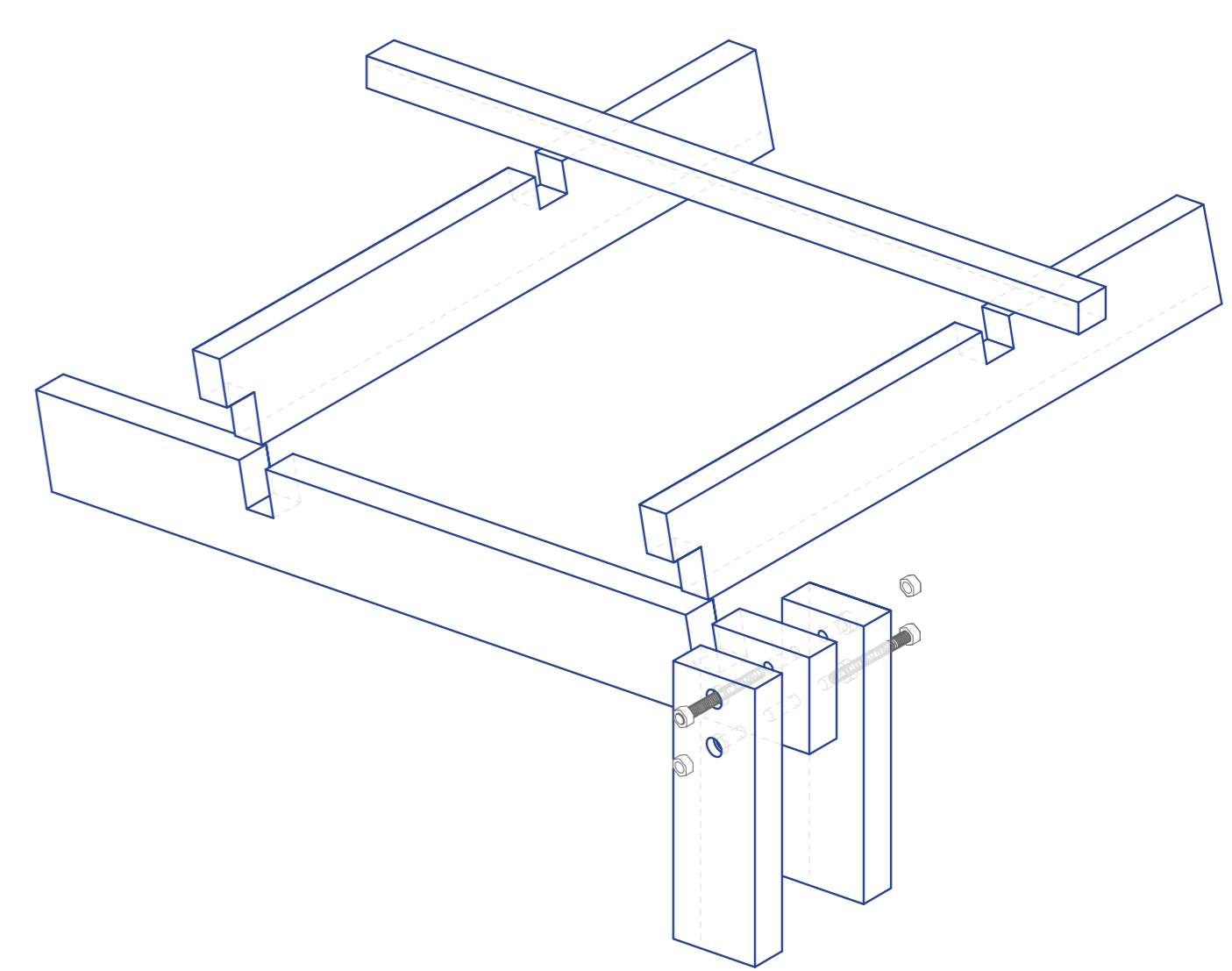
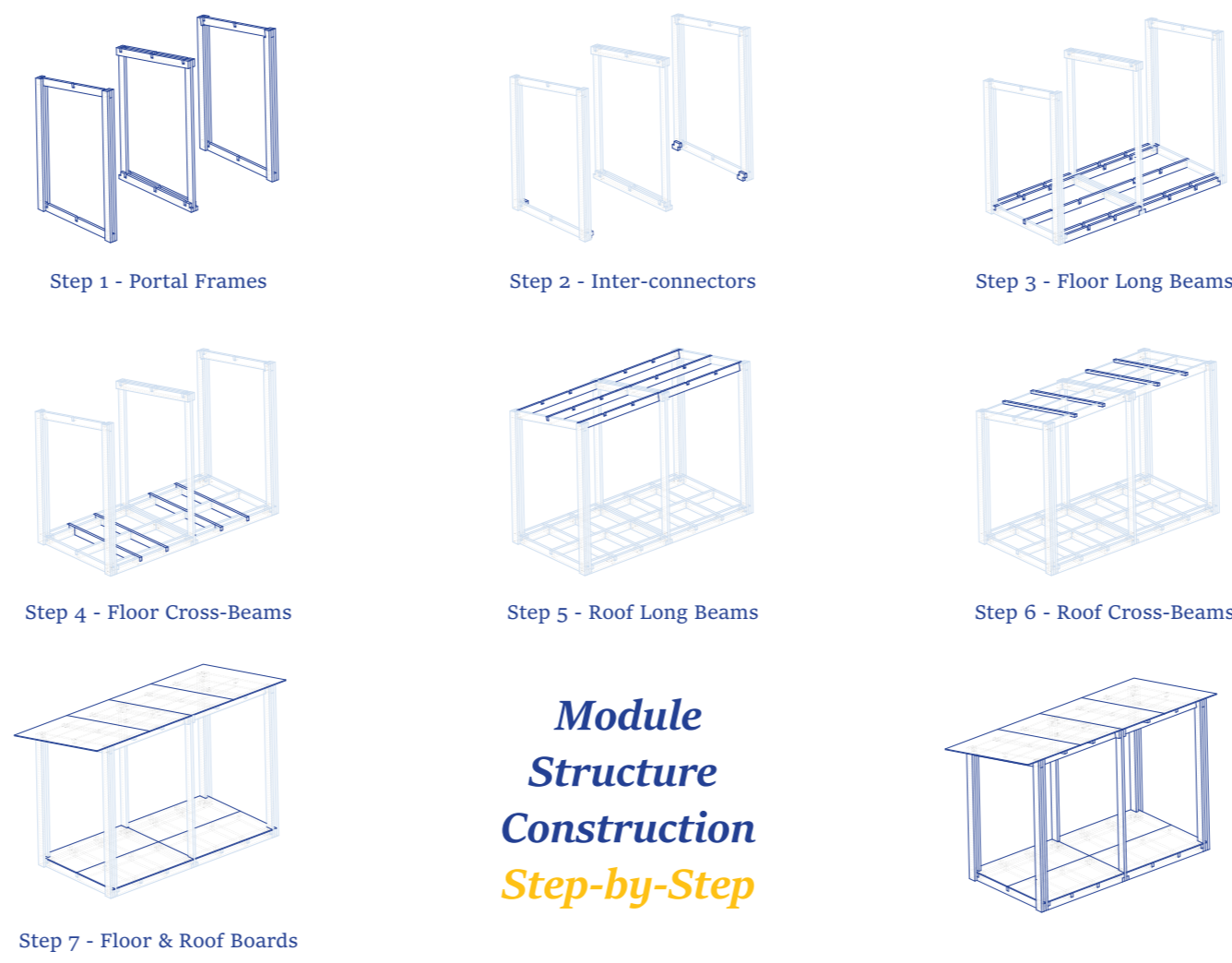

Top Corner Structure Detail 1:10

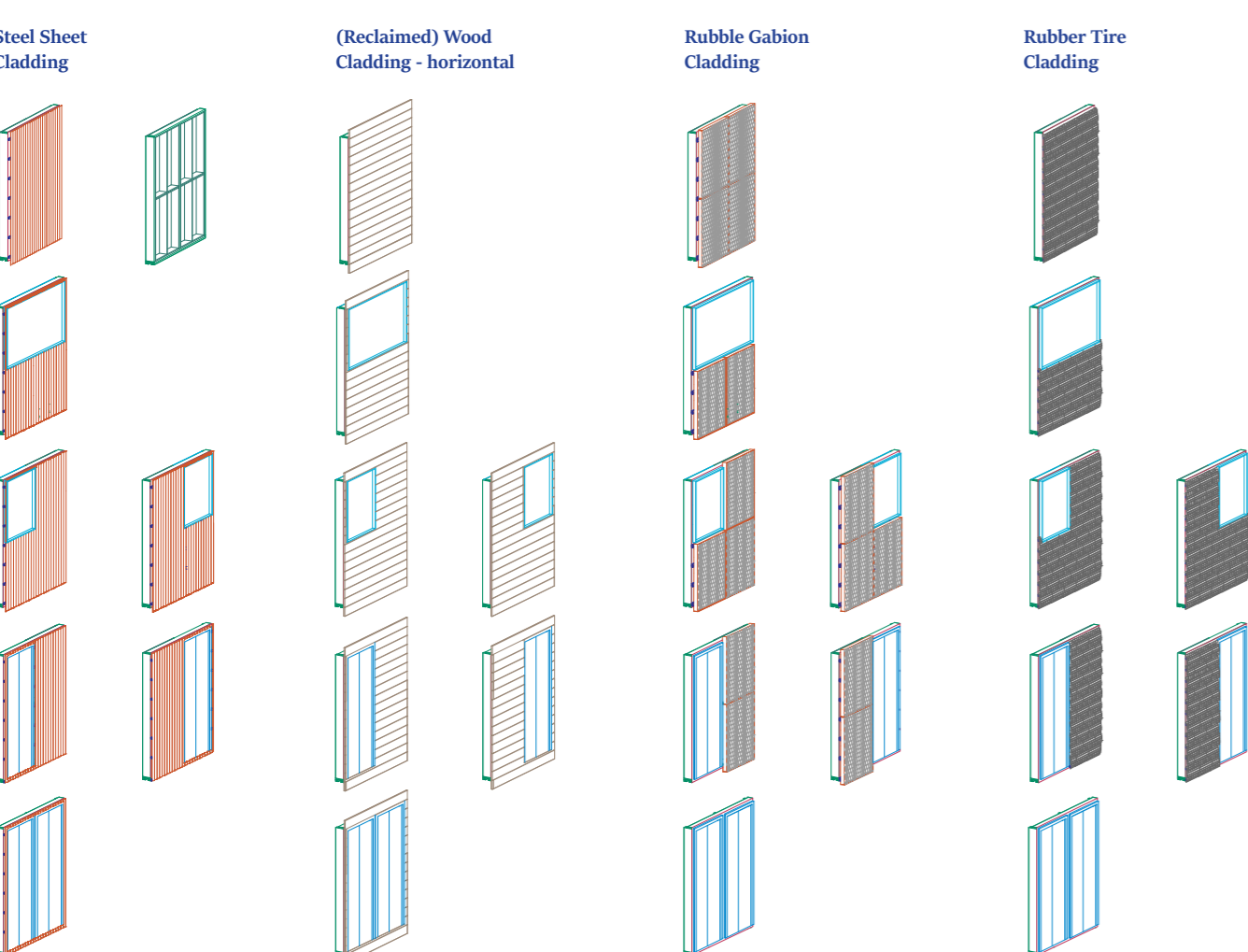

Cladding Materialization Variants and Wall Configurations

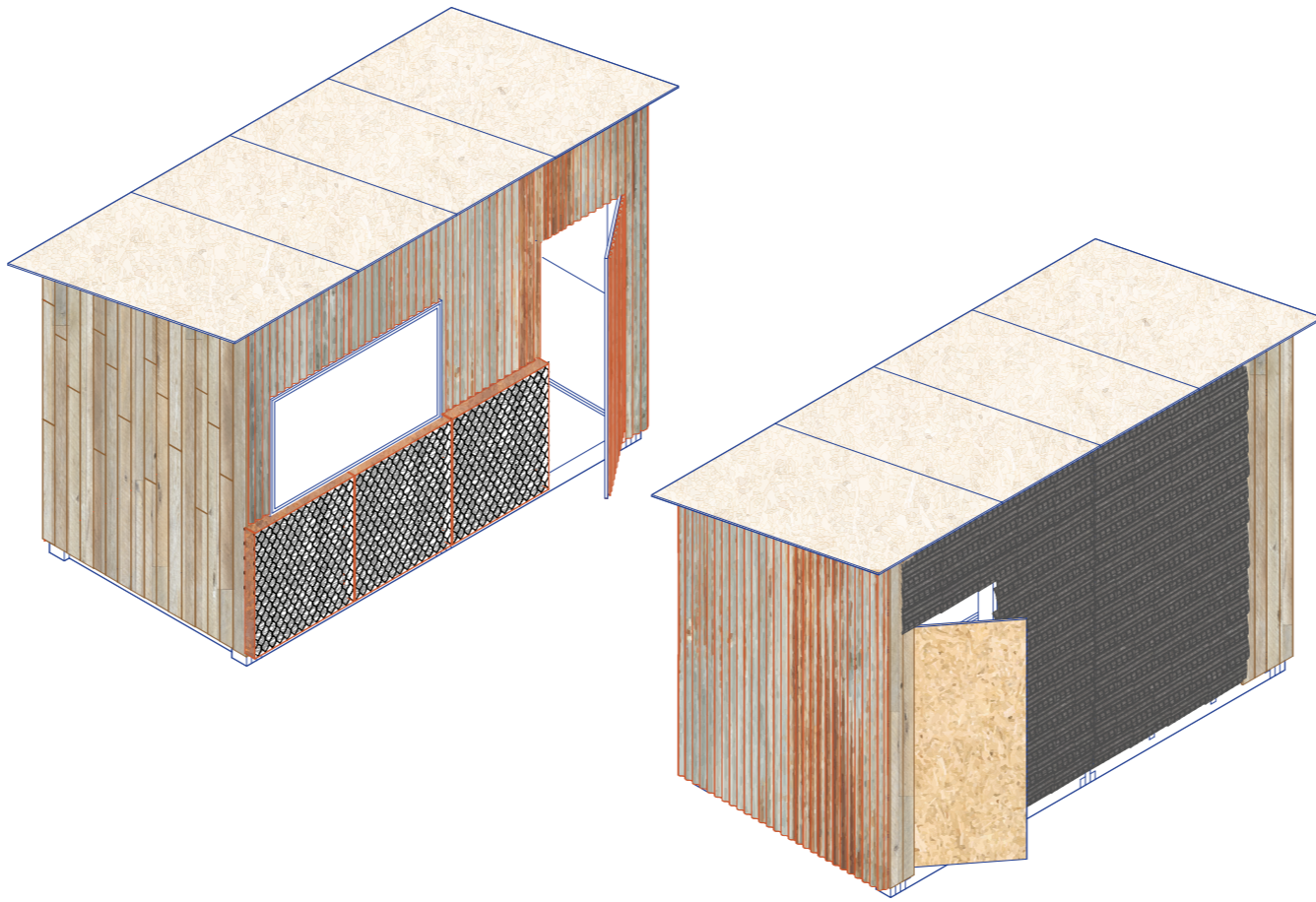

Materialization Render Example (Mixed Materials based on Resource Availability)

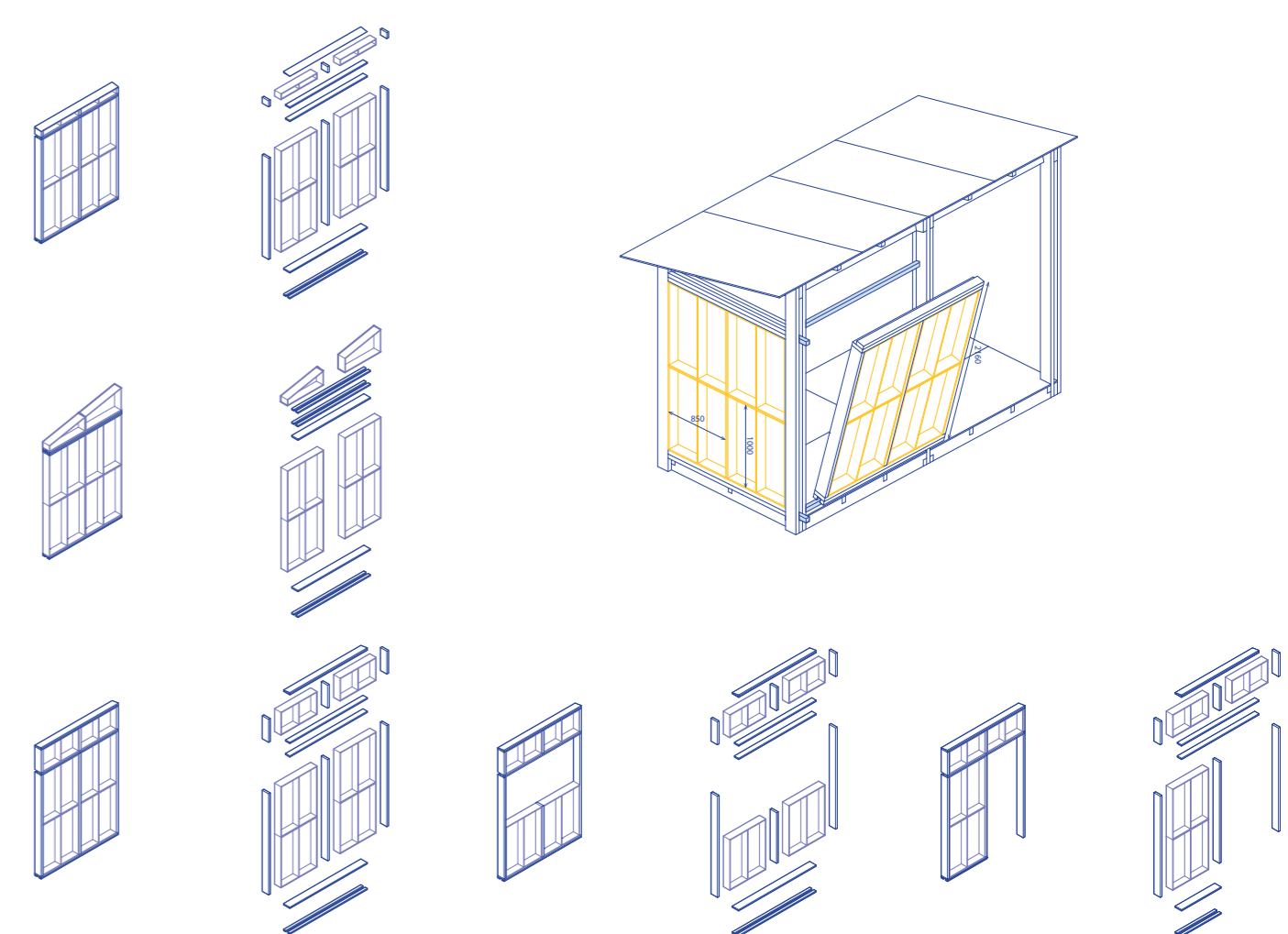

Wall Composition and Structural Breakdown

SECOND DESIGN PHASE - 2027 - EXPANDING PROGRAMME



Residential Module Visualization - Information Centre



Large Module Visualization - Lecture and Workshop Space - Outside - Summer

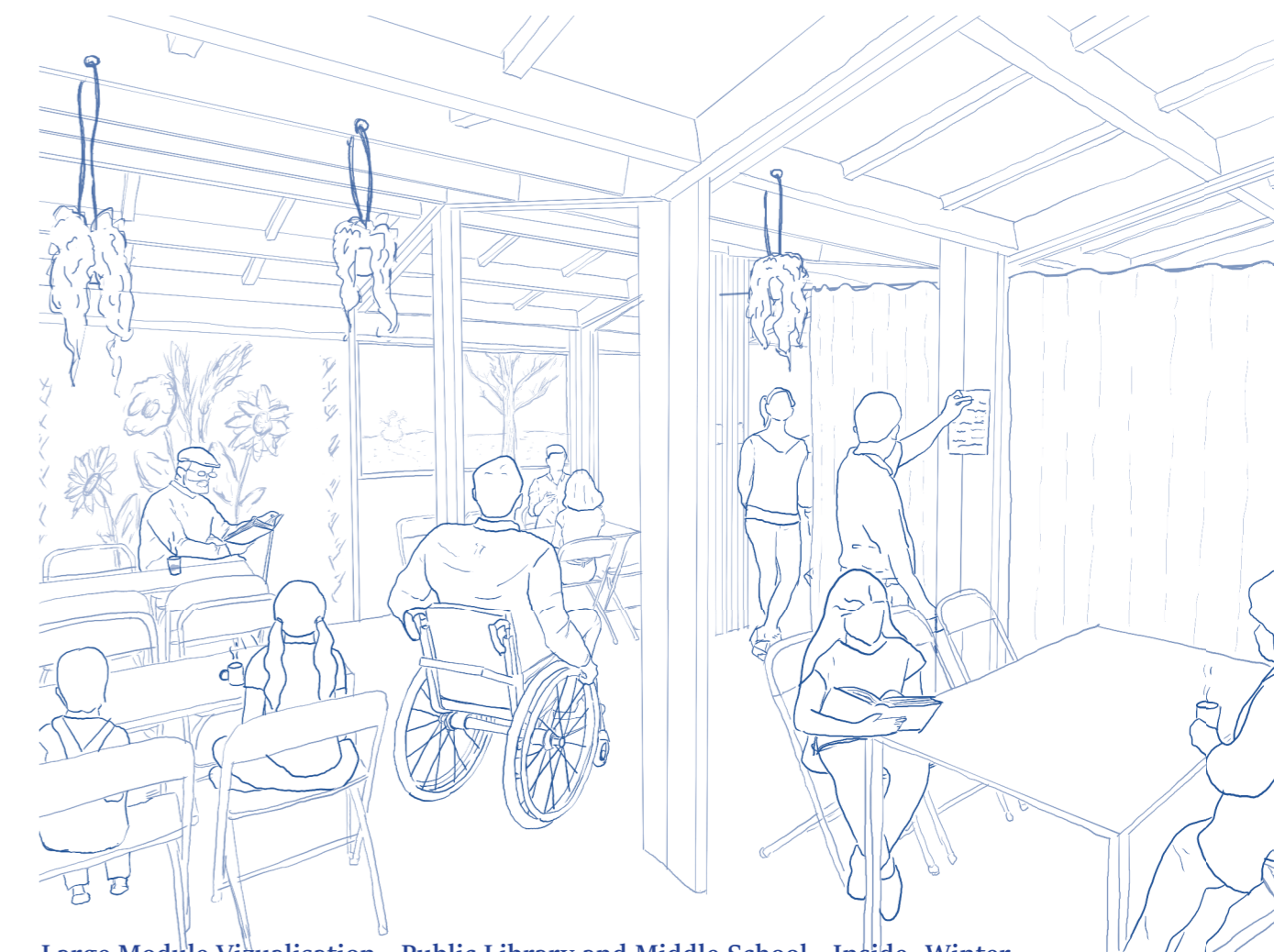

Large Module Visualization - Public Library and Middle School - Inside - Winter

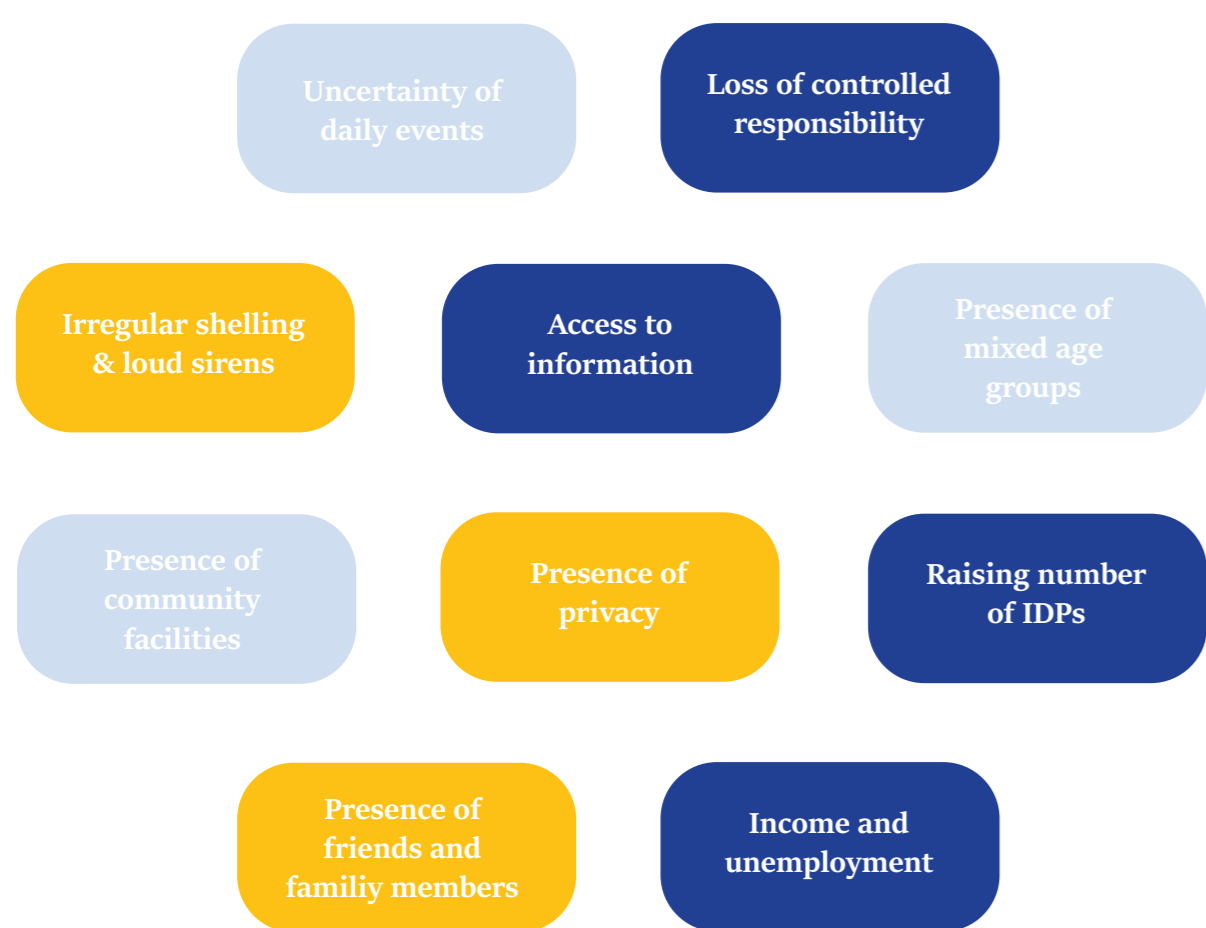

Variables affecting the perception of autonomy in IDPs

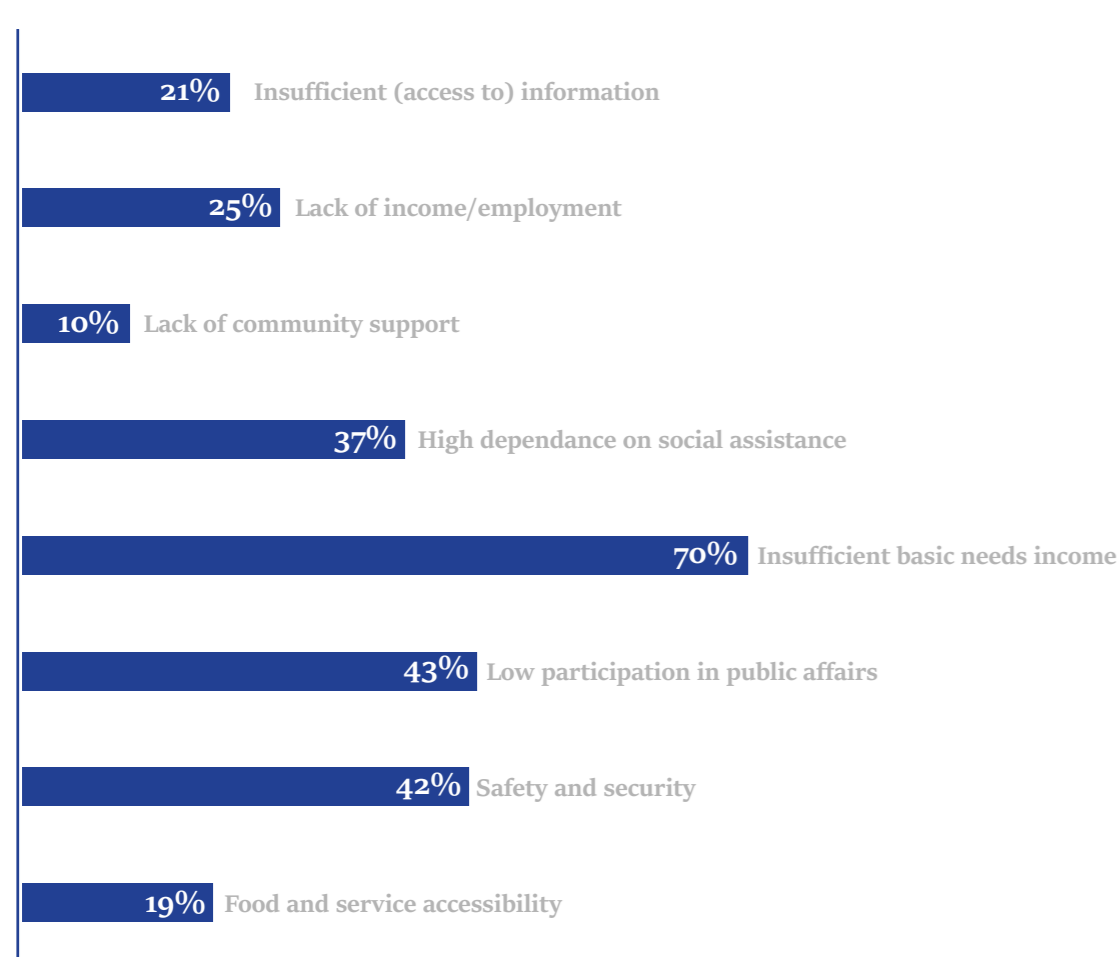

Factors affecting the perception of well-being in IDPs (%)

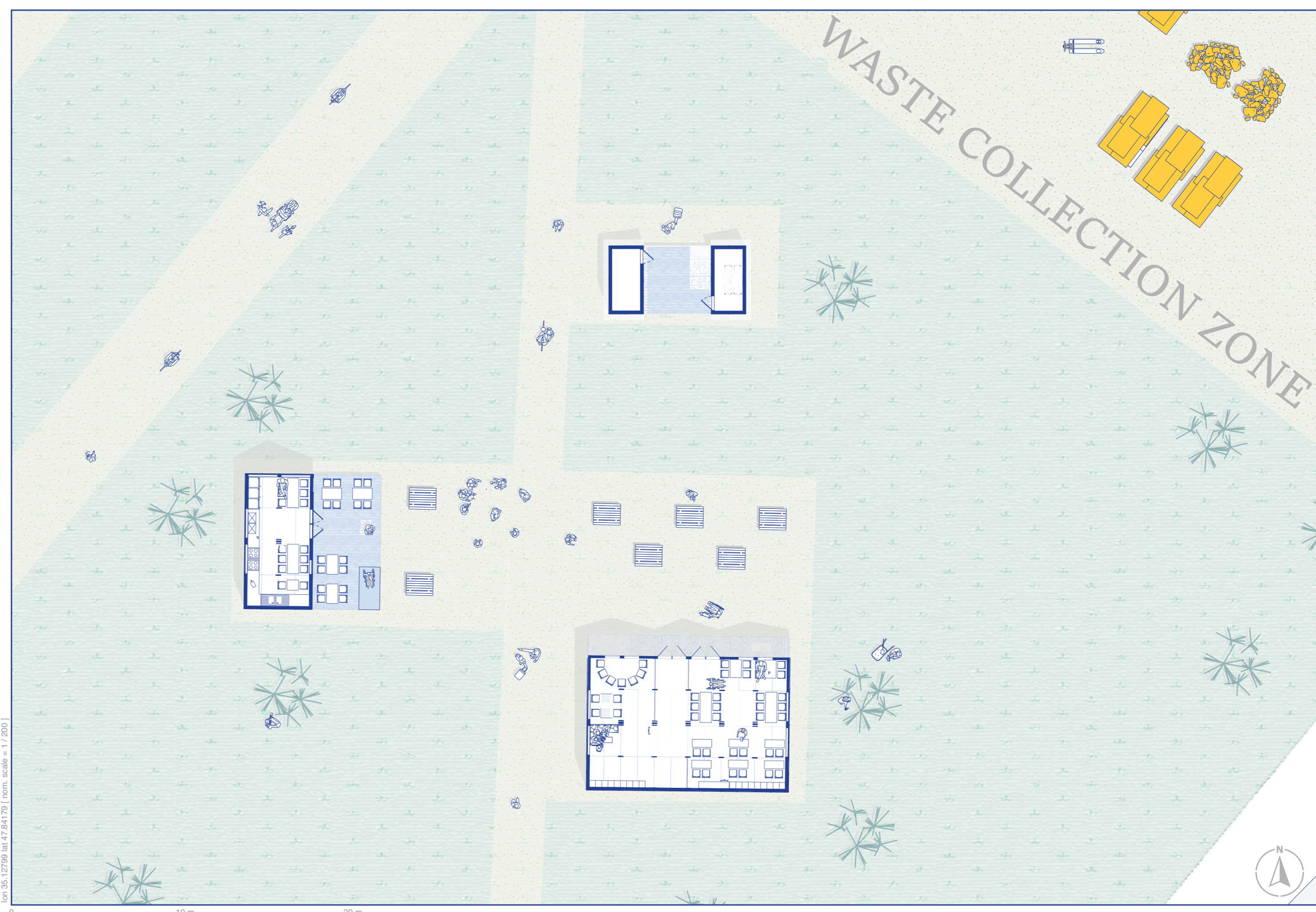

Site Plan Second Design Stage - Large Modules - Skill Based Functions - 1:200

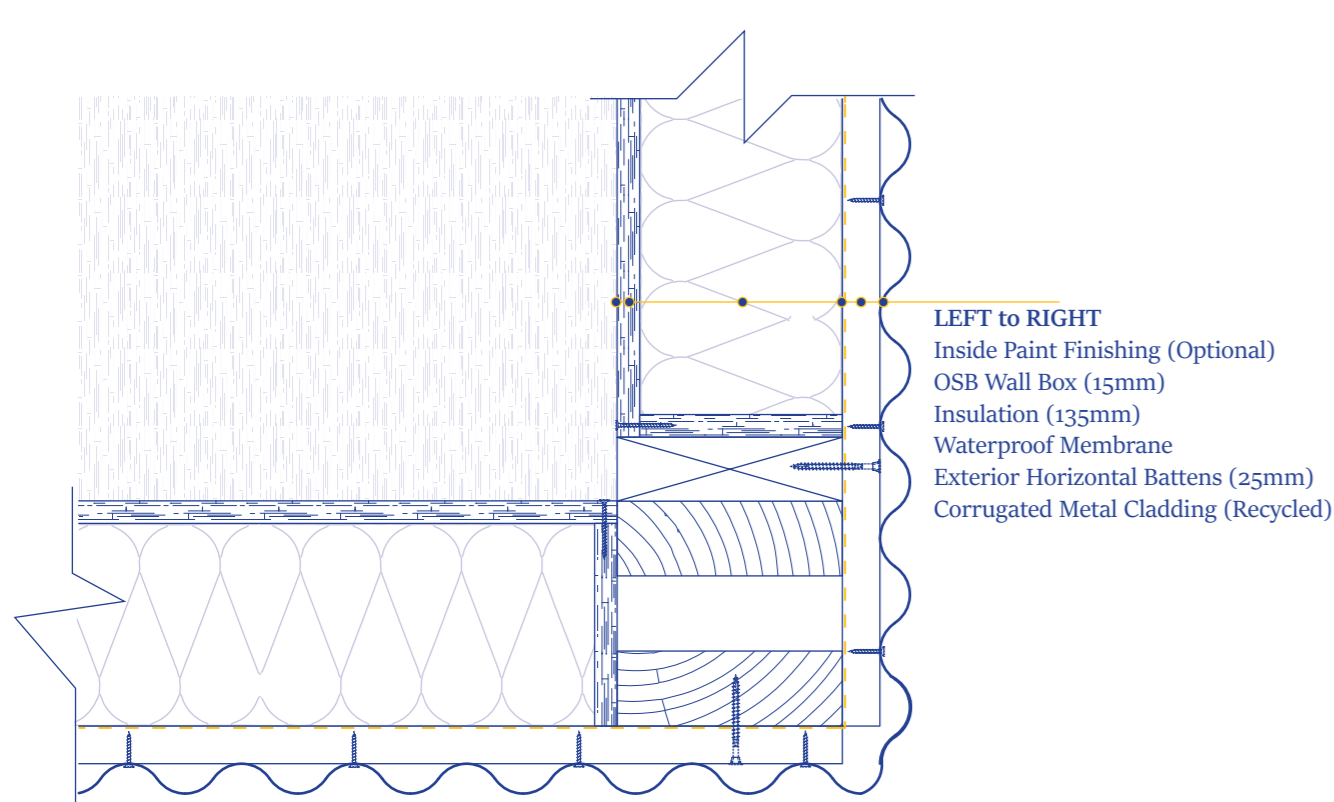

Corner Detail - Horizontal 1:5

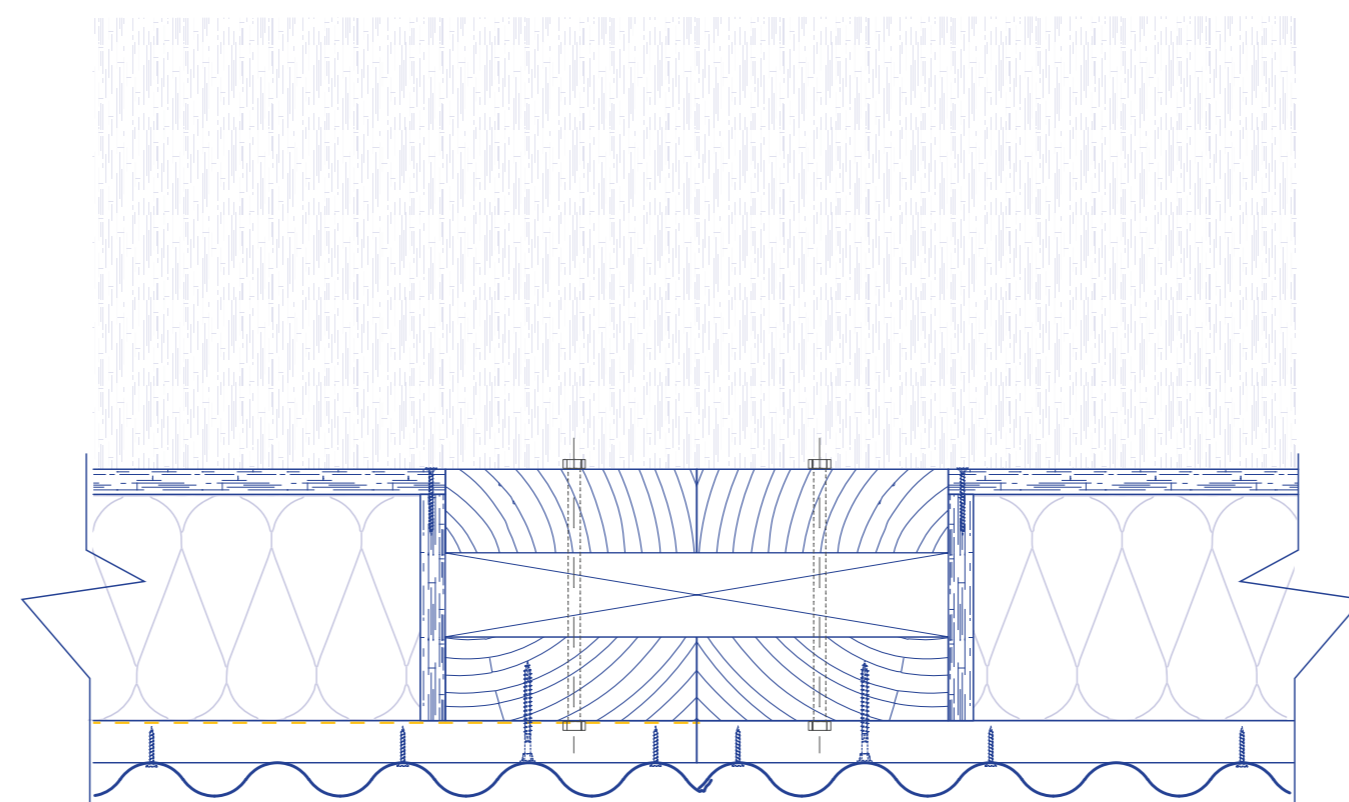

Module to Module Connection Detail - Horizontal 1:5

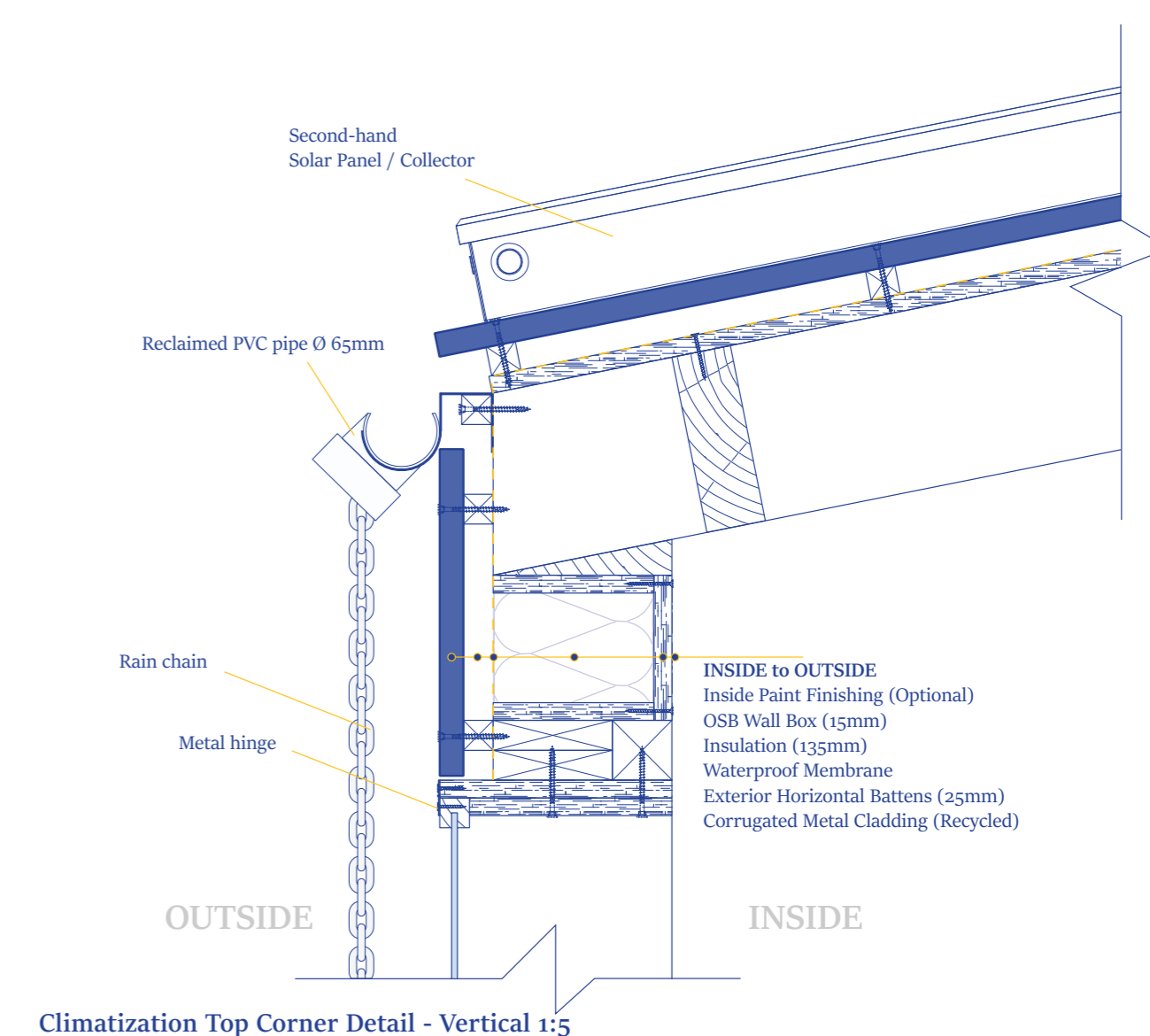

Climatization Top Corner Detail - Vertical 1:5

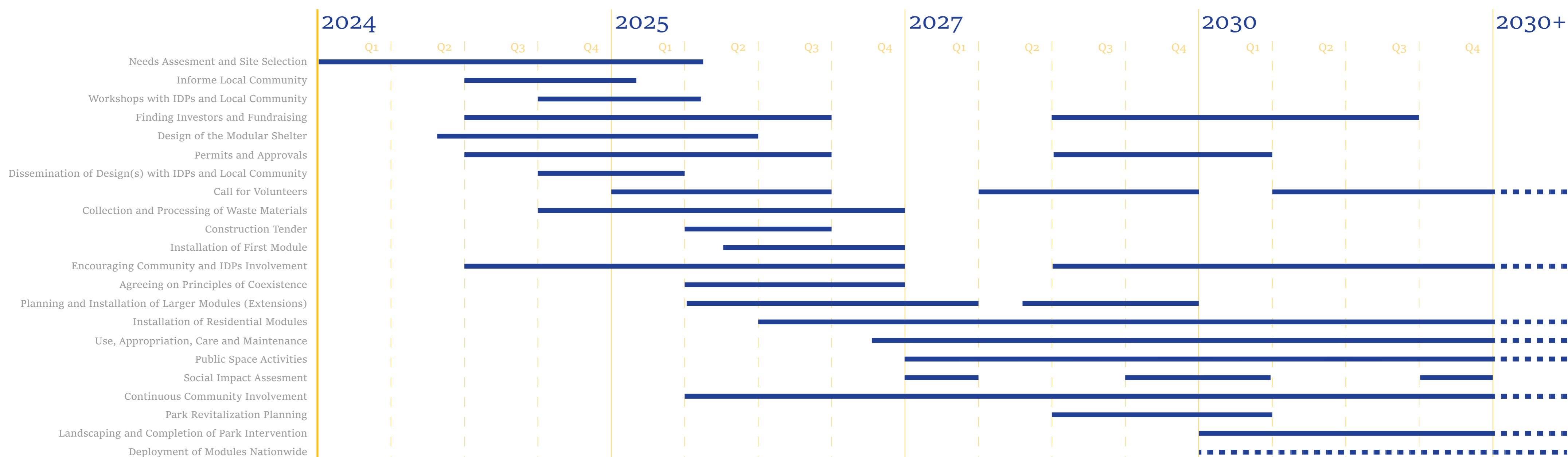

THIRD DESIGN PHASE - 2030 - (RE)CLAIMING SPACE

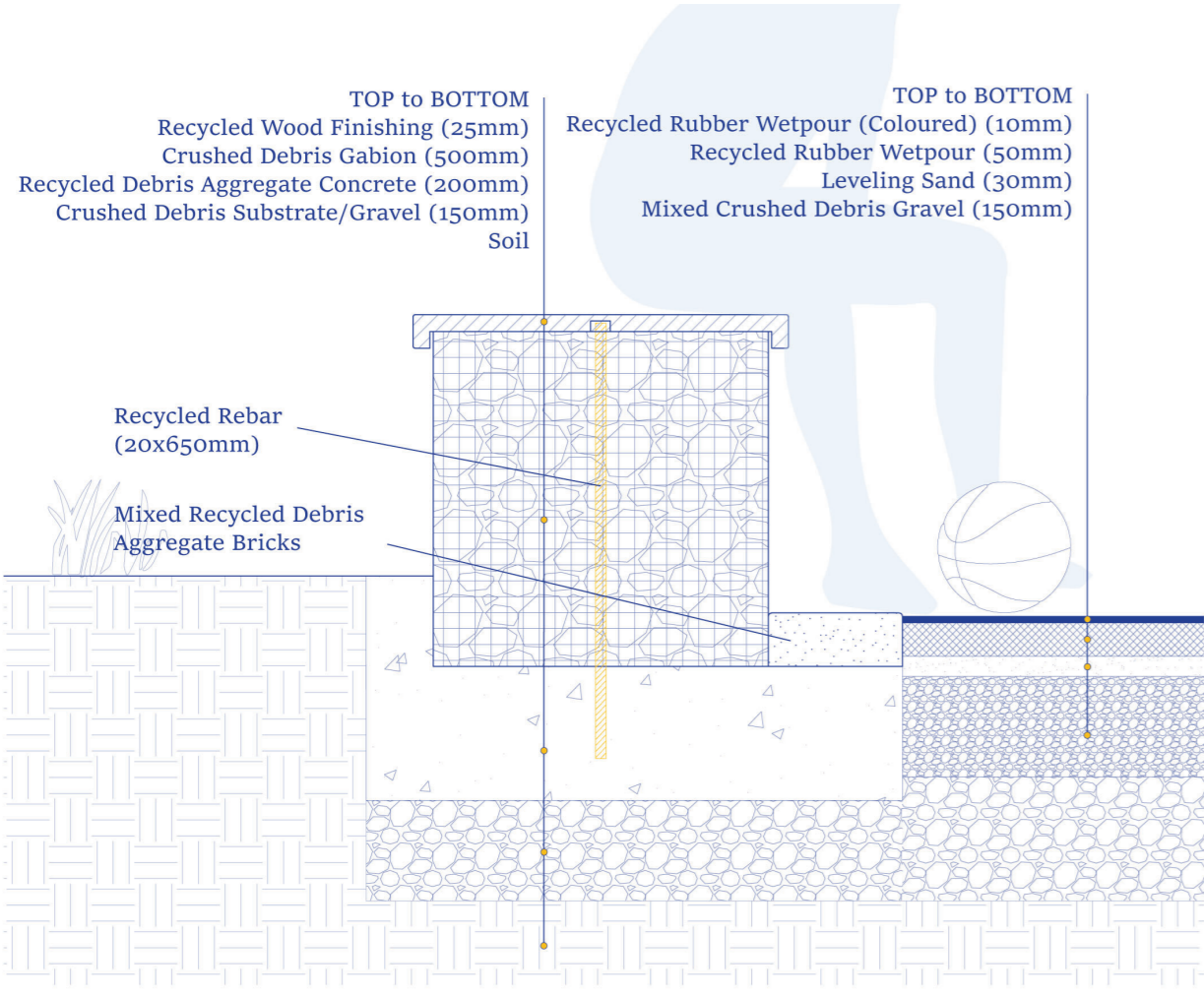

Gabion Bench - Basketball Court Detail - Vertical 1:10

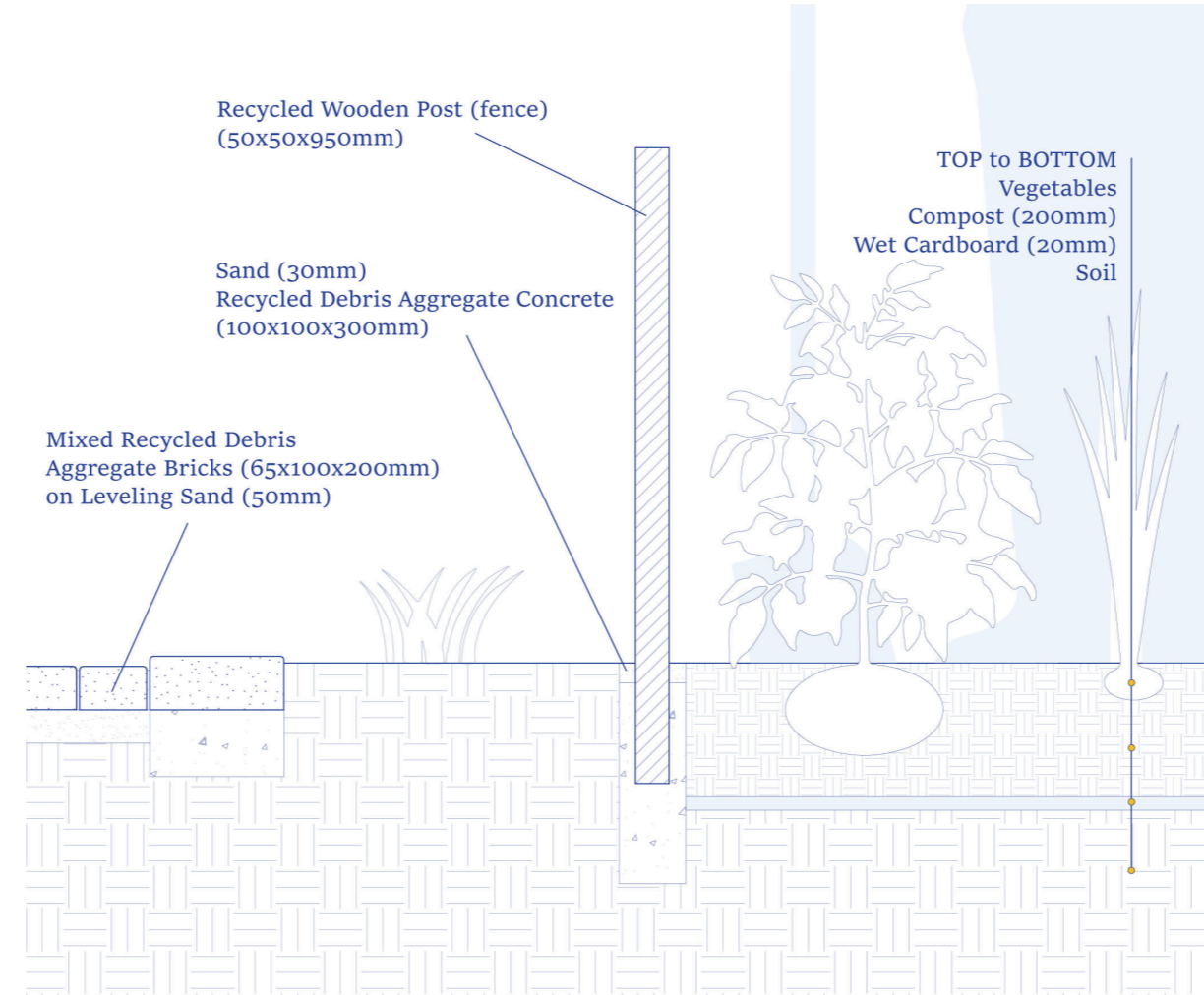

Vegetable Garden Detail - Vertical 1:10

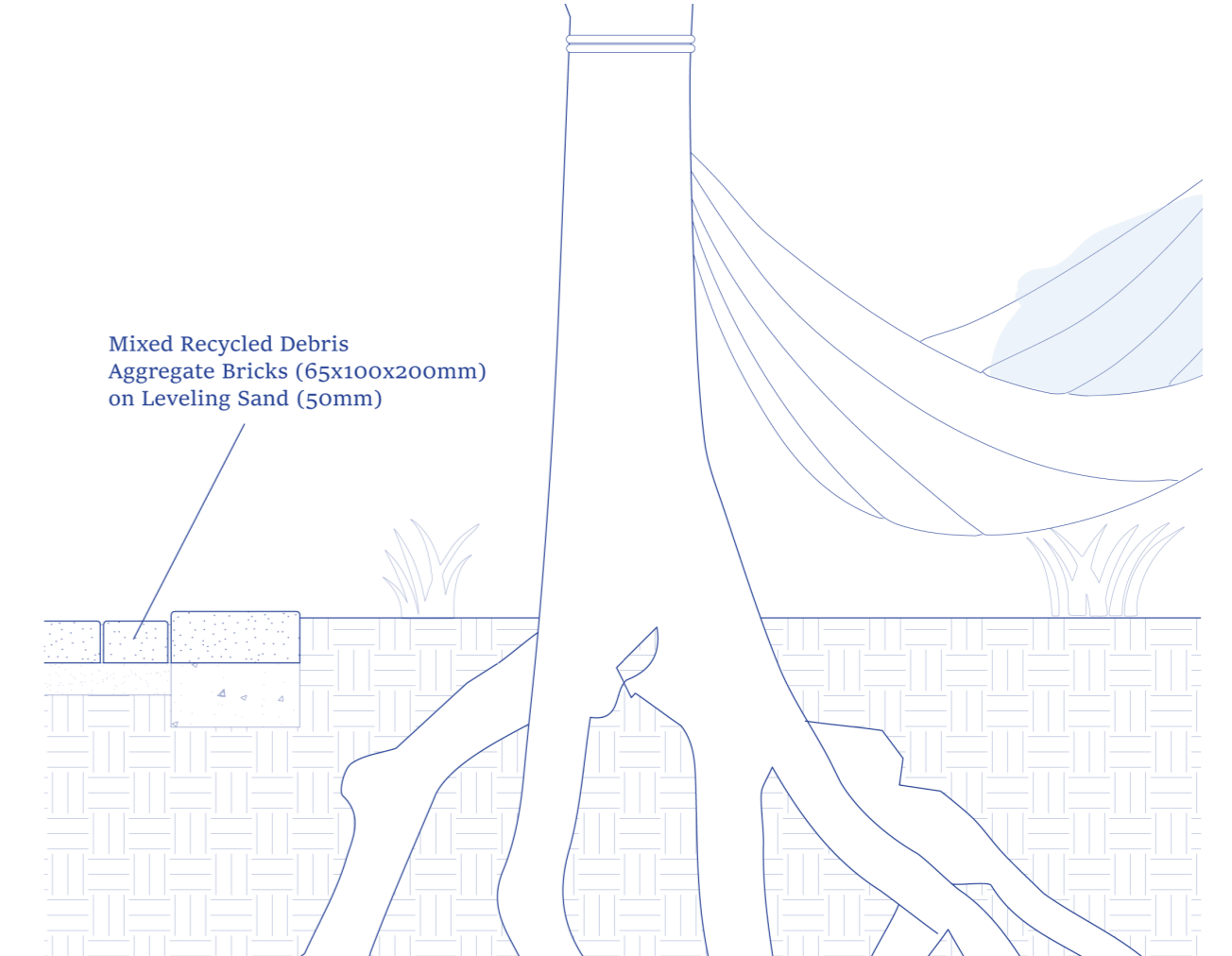

Relaxation Area - Hammock and Tree Detail - Vertical 1:10

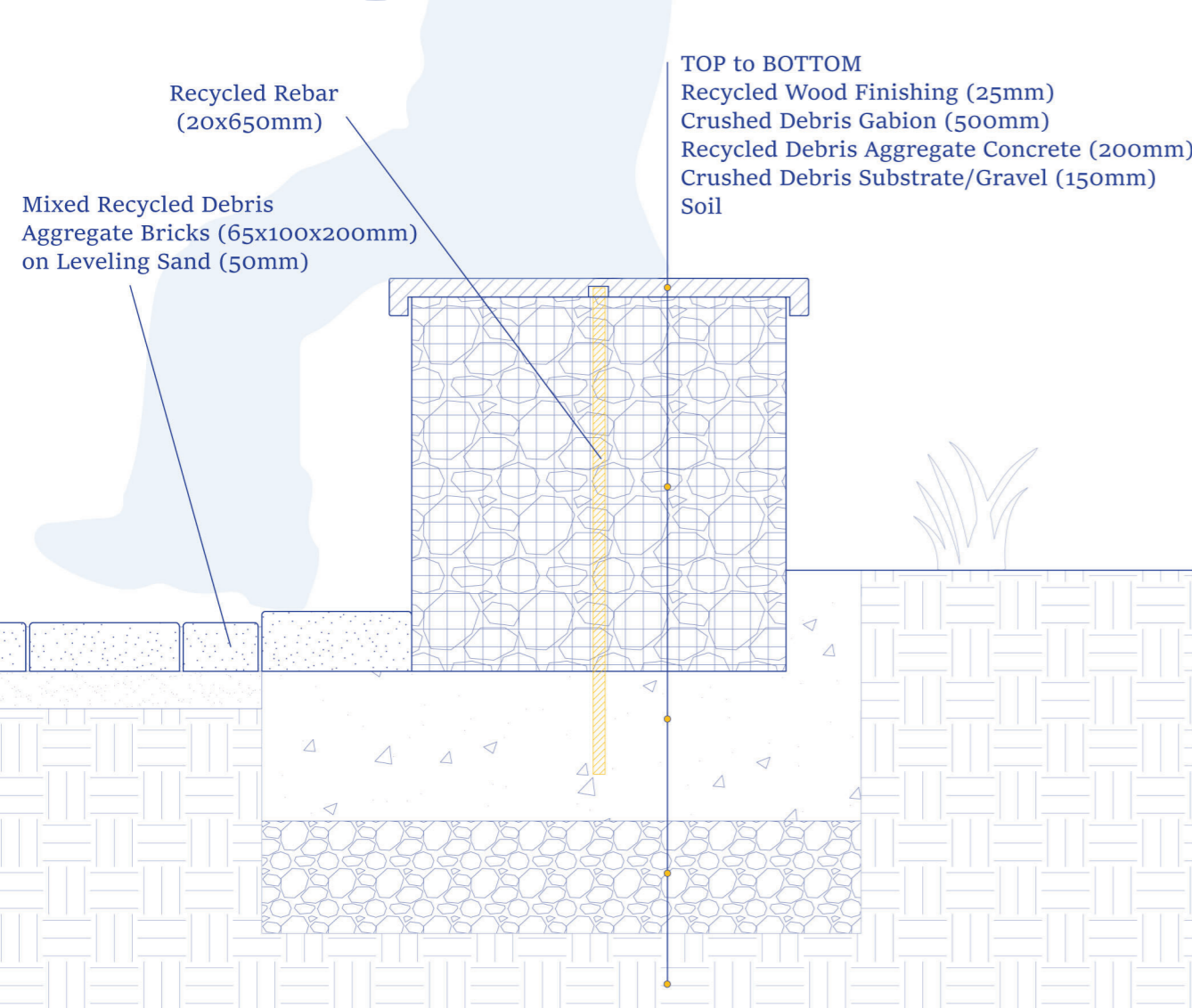

Gabion Bench - Walking Path Detail - Vertical 1:10

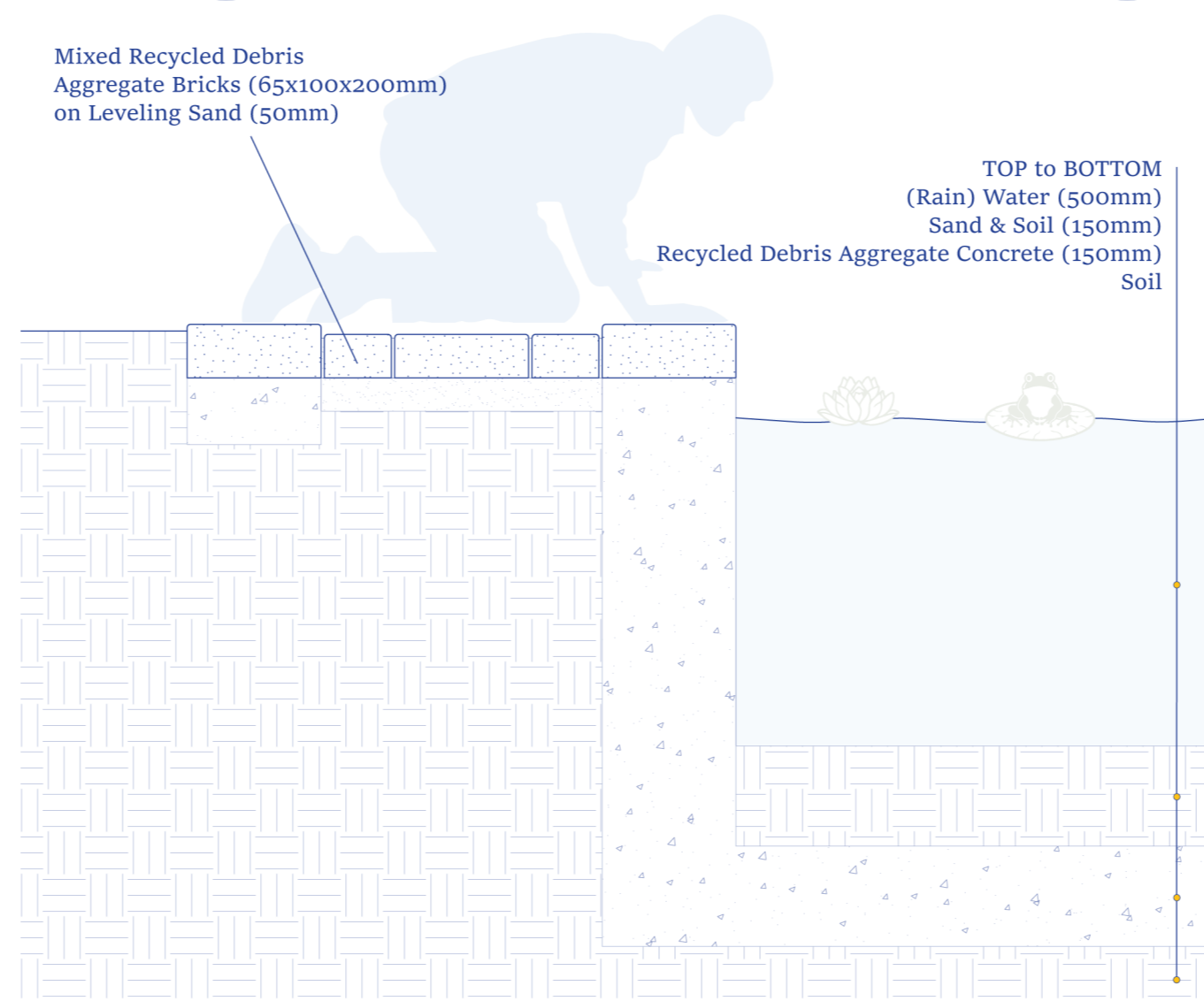

(Rain Water) Pond Detail - Vertical 1:10

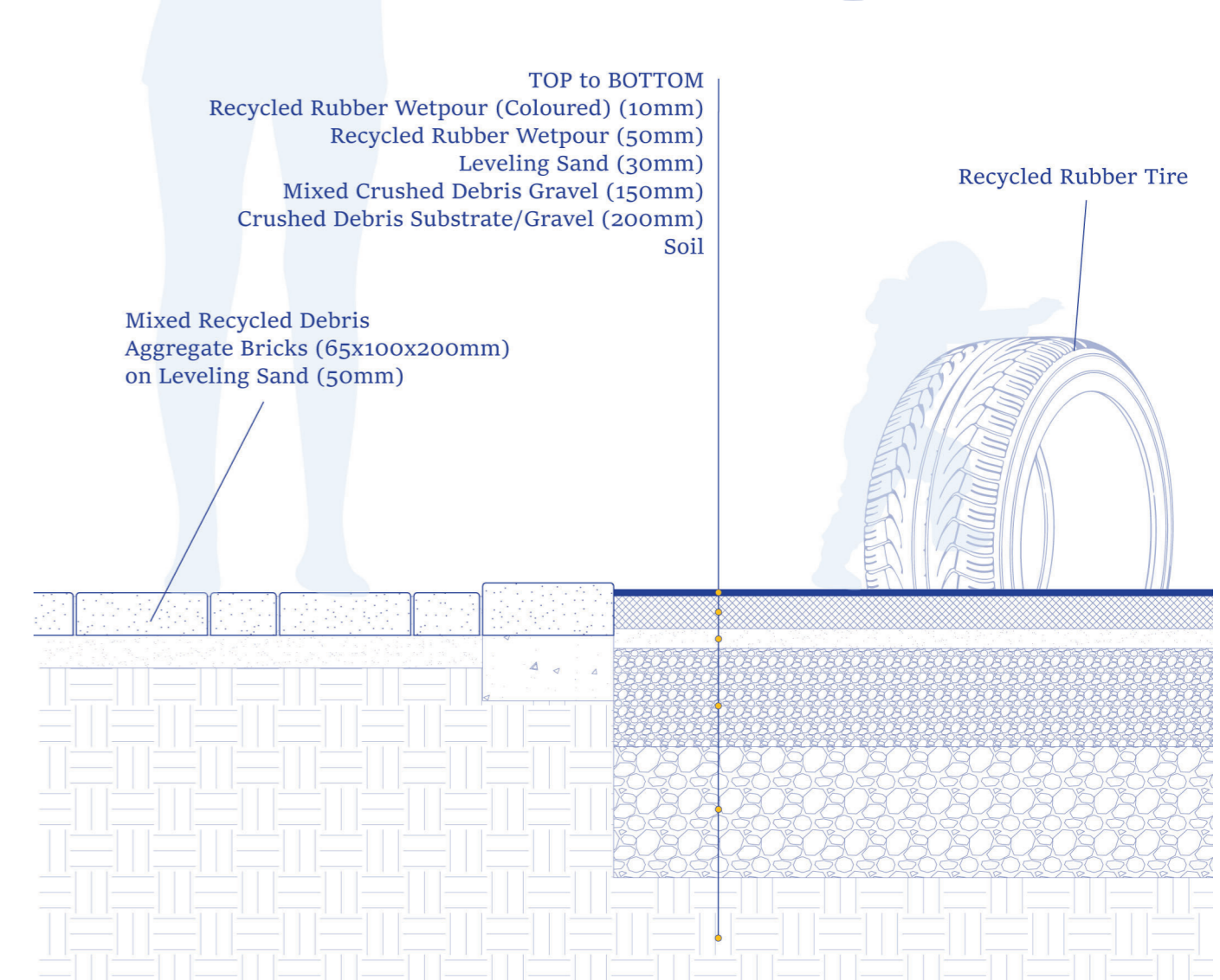

Children (After-)School Area - Playground Detail - Vertical 1:10

<p>Physical Capital</p> <ul style="list-style-type: none"> Destroyed housing Lack of (functioning) community amenities Lack of support services 	<ul style="list-style-type: none"> - Loss of belongings, documentation and properties - Limited growth and self-development - Health issues and loss of livelihood 	<p>Sustainable community development</p> <ul style="list-style-type: none"> - Accessible (governmental) information - Local community support groups - Accessible NGOs social services - Recycling construction techniques and materials
<p>Financial Capital</p> <ul style="list-style-type: none"> Low household housing Lack of economic opportunities Fragmented & limited governmental aid 	<ul style="list-style-type: none"> - Increased poverty - High unemployment rate - Lack of (skilled) social workers - More pressure on political and commercial services 	<p>Livelihood opportunities</p> <ul style="list-style-type: none"> - Service trading - Joint / Shared working opportunities - Skills workshops and training - Responsibility and tasks delegation
<p>Social & Human Capital</p> <ul style="list-style-type: none"> Health issues Lack of social opportunities Displacement & isolation 	<ul style="list-style-type: none"> - High mortality rate - Forced to live in isolated shelters - Decreasing mental health - Lack of social integration (in local community) 	<p>Human Development</p> <ul style="list-style-type: none"> - Access to medical resources - Mix of activities and programme - Local community integration - Mental health support groups
<p>Nature Capital</p> <ul style="list-style-type: none"> Lack of planned public parks Industrial air pollution Low urban biodiversity 	<ul style="list-style-type: none"> - Imbalanced urban fabric - Poor air quality - Threat to people's health - Loss of natural ecosystems 	<p>Densification</p> <ul style="list-style-type: none"> - Planting new trees and wildflowers - Regulated use of industrial factories - Revival of biodiversity - Community gardens

CLIMATIC ASPECTS & SYSTEMS

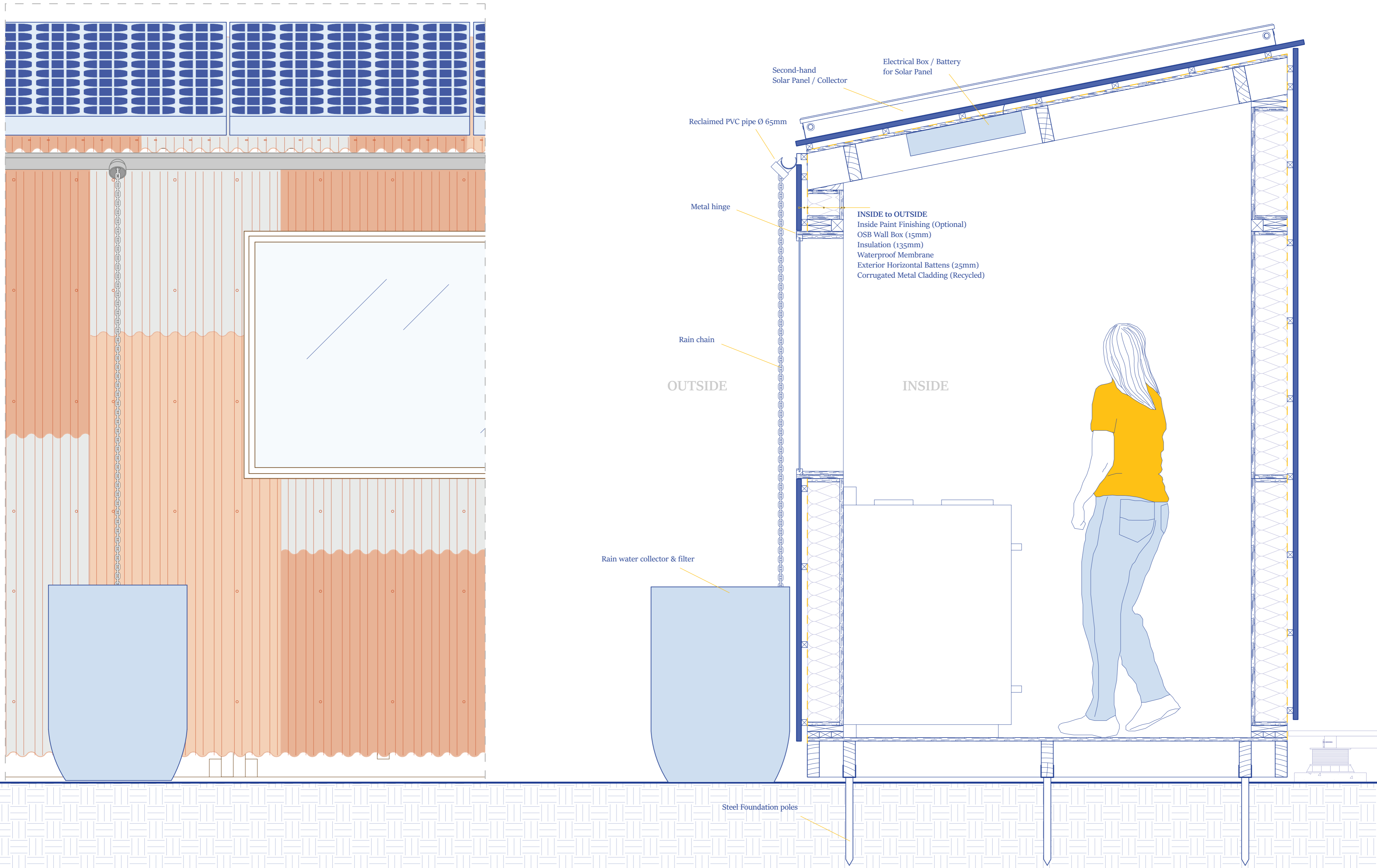

Combination Drawing Detail - Elevation - Section - Floorplan - Small Module - Shared Kitchen 1:10

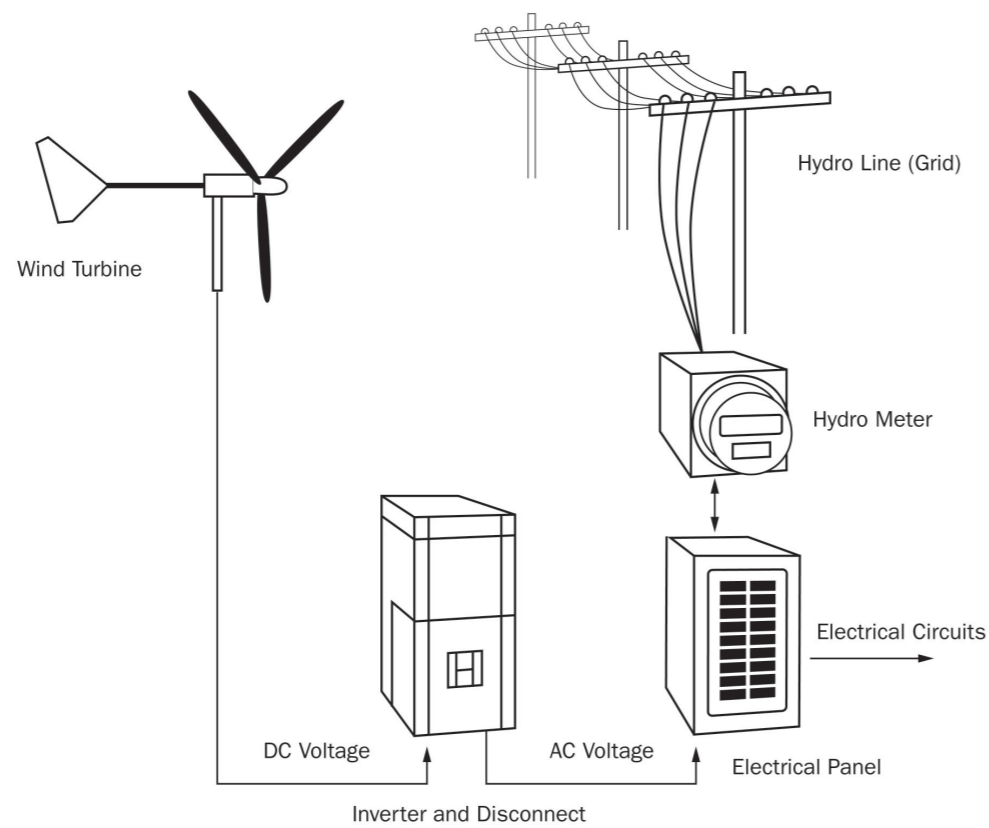

Energy Production Systems - Solar Panel PV Cells - Windmills



Heating & Cooking Systems - U Pipe Solar Collector - Butane Gas Tank (cooking) - Portable Radiator

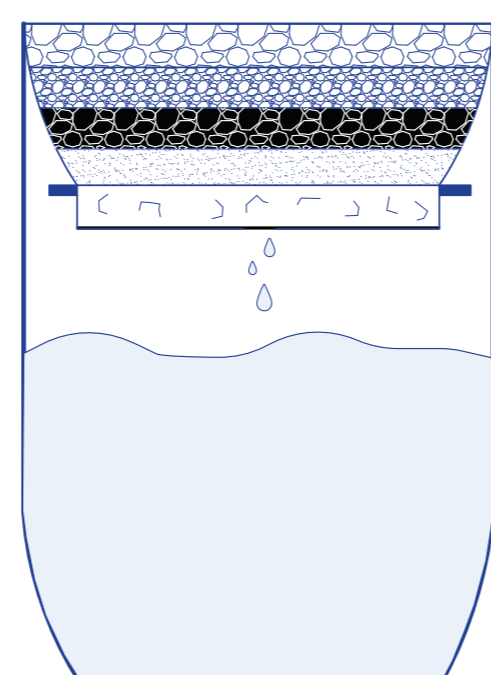

- TOP to BOTTOM
- Rocks
- Gravel & Pebbles
- Charcoal
- (Fine) Sand
- Cotton
- Sieve

Rain Water Filtering Tank - Repurposed Plastic Barrel

