

OpenLEGO demonstration

A link between AGILE and OpenMDAO

de Vries, Daniël; van Gent, Imco; La Rocca, Gianfranco; Binder, Simon

Publication date

2017

Document Version

Final published version

Citation (APA)

de Vries, D., van Gent, I., La Rocca, G., & Binder, S. (2017). *OpenLEGO demonstration: A link between AGILE and OpenMDAO*. First European OpenMDAO workshop, Toulouse, France.

Important note

To cite this publication, please use the final published version (if applicable).
Please check the document version above.

Copyright

Other than for strictly personal use, it is not permitted to download, forward or distribute the text or part of it, without the consent of the author(s) and/or copyright holder(s), unless the work is under an open content license such as Creative Commons.

Takedown policy

Please contact us and provide details if you believe this document breaches copyrights.
We will remove access to the work immediately and investigate your claim.

OpenLEGO demonstration

A link between AGILE and OpenMDAO

Daniël de Vries, Imco van Gent (speaker)

Supervisors:

dr. Gianfranco La Rocca (TU Delft)

Simon Binder (Airbus)

Session: Link CMDOWS to OpenMDAO
13th of October 2017, 10:00-10:30h

First European OpenMDAO Workshop
12-13 October 2017, Toulouse, France



Contents

- The big picture
- Demo time!
- Recap
- Questions

The big picture



Pool of Simulation Tools



Integration and Optimization environments

The big picture

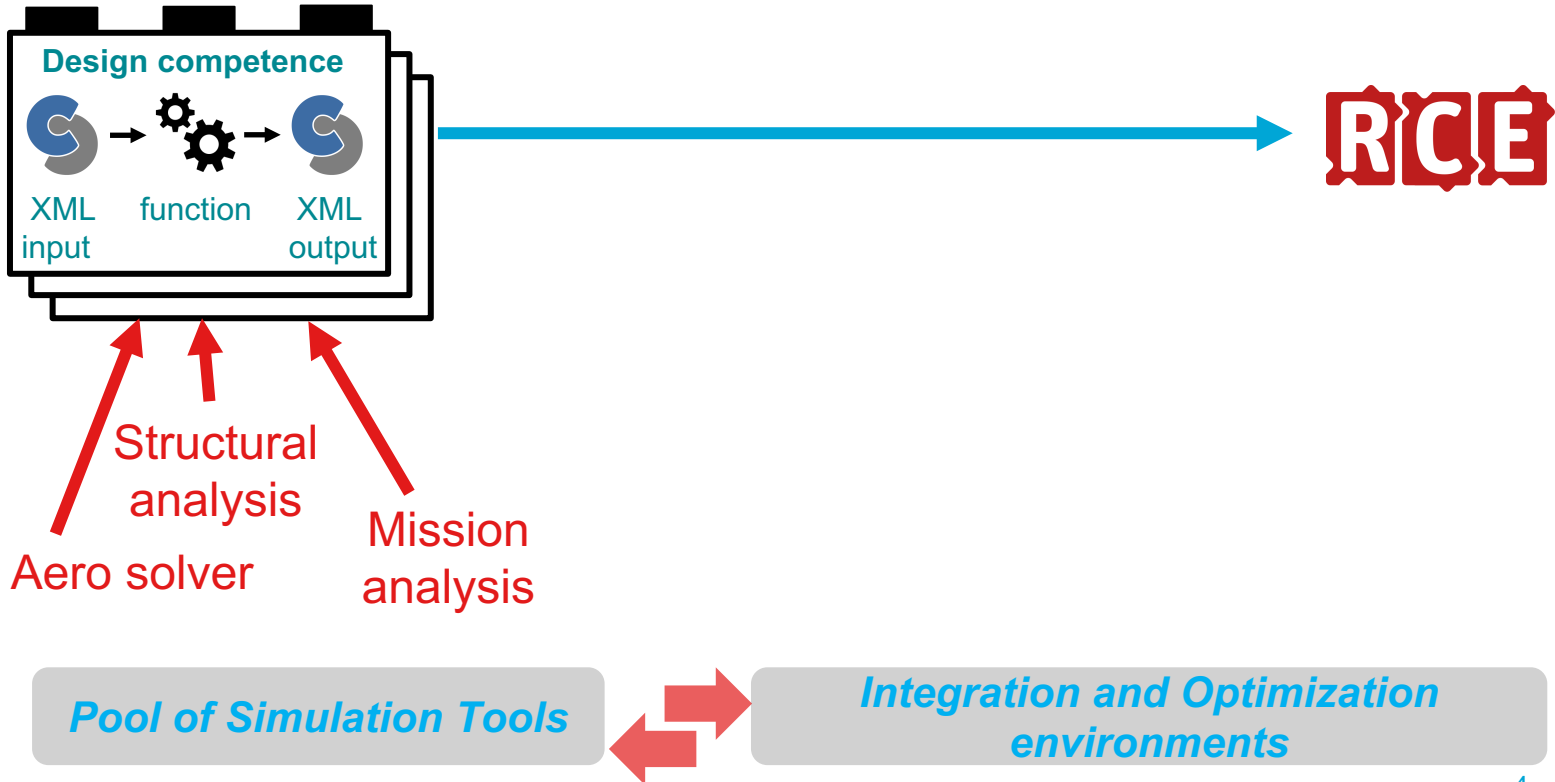

The big picture

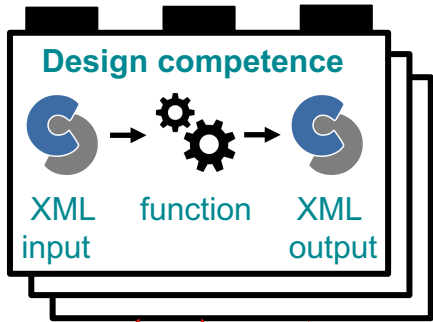

Aero solver

Structural analysis

Mission analysis



RICE

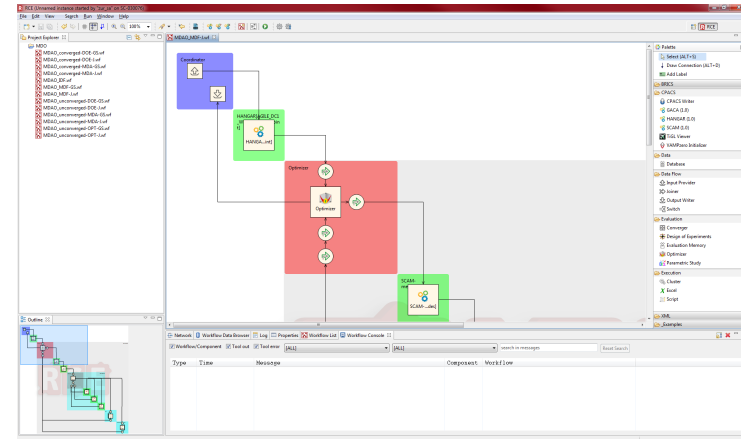

Pool of Simulation Tools



Integration and Optimization environments

The big picture



Instead of making **running** optimizations cheap and easy,

we want to:

make **setting up** collaborative optimizations cheap and easy.

The big picture

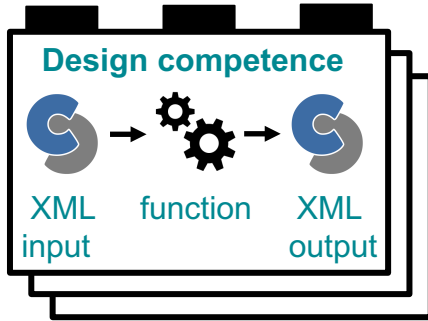

KADMOS

RCE

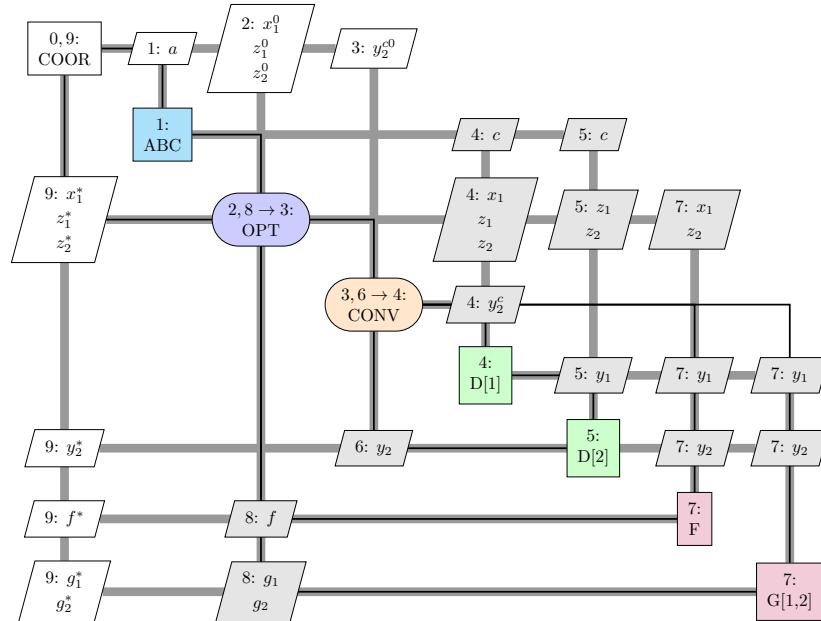

The big picture

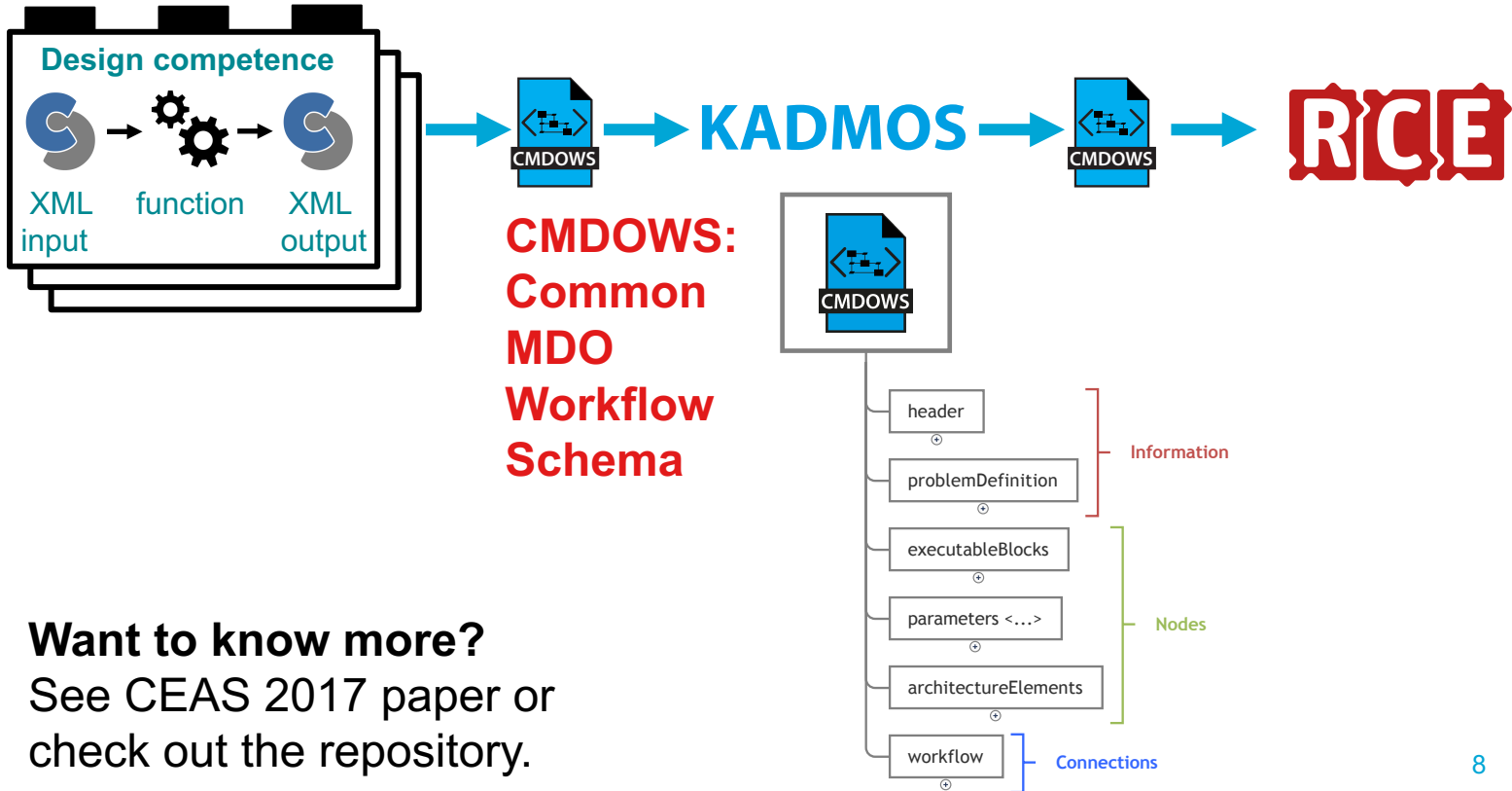

Want to know more?
See CEAS 2017 paper or
check out the repository.

The big picture



The big picture



The big picture



The big picture



Made by
Daniël de Vries

=
OpenLEGO
(Open-source Link
between AGILE and
OpenMDAO)

Demo time!



▼ seller_OpenMDAO_workshop

__init__.py

D1.py

D2.py

D3.py

D4.py

F1.py

F2.py

G1.py

G2.py

G3.py

seller.xsd

Demo time!

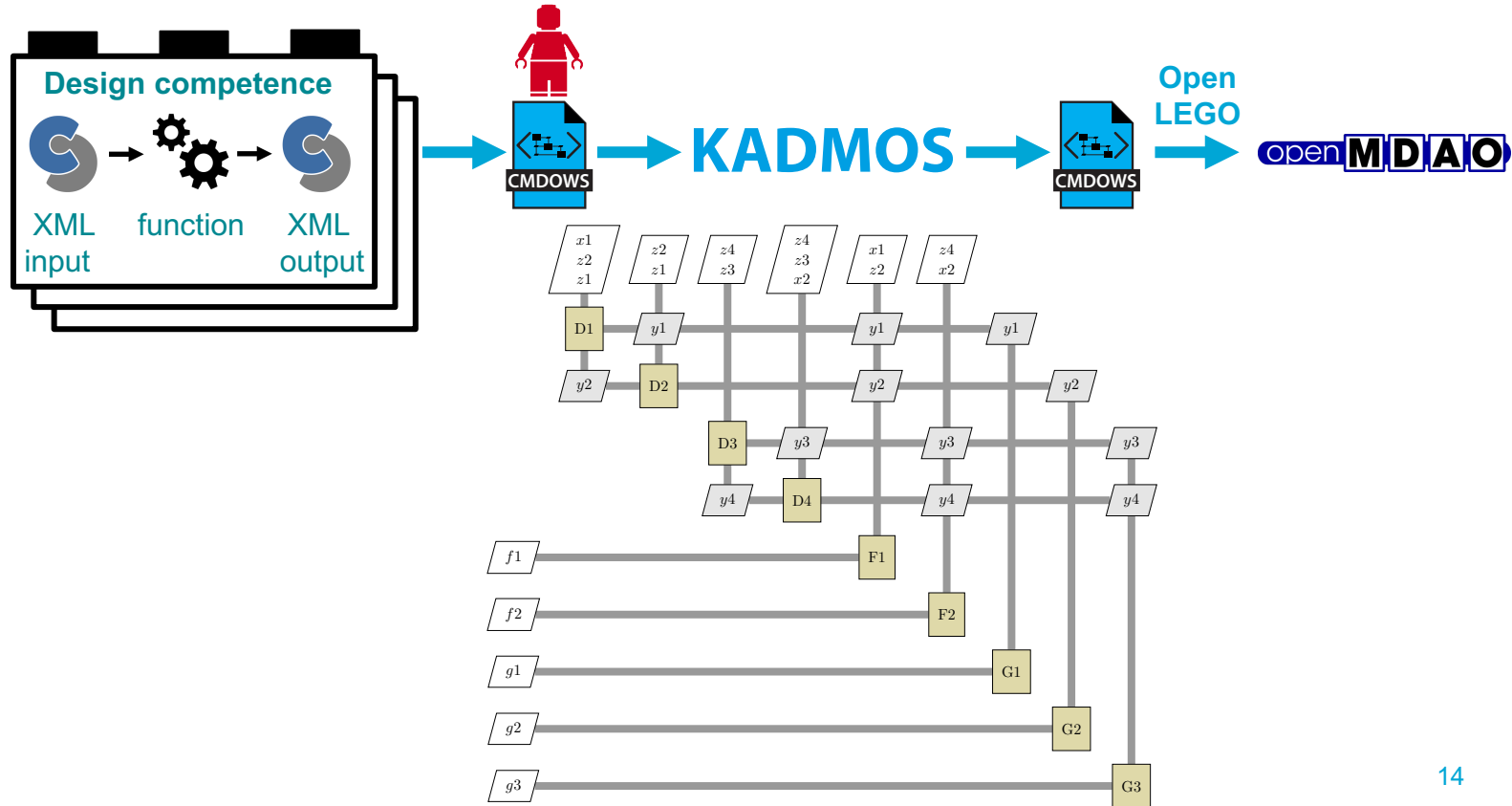

Demo time!

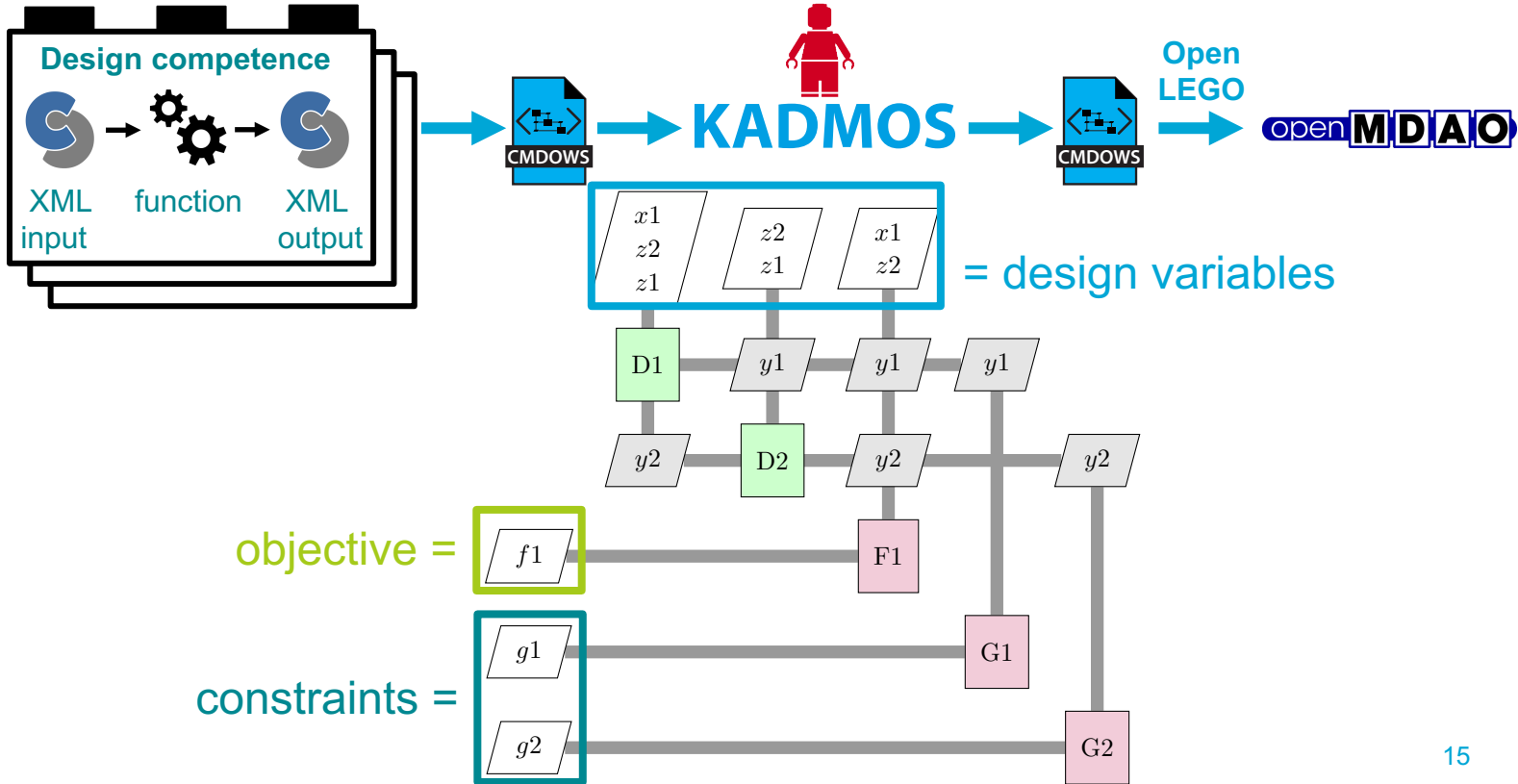

Demo time!

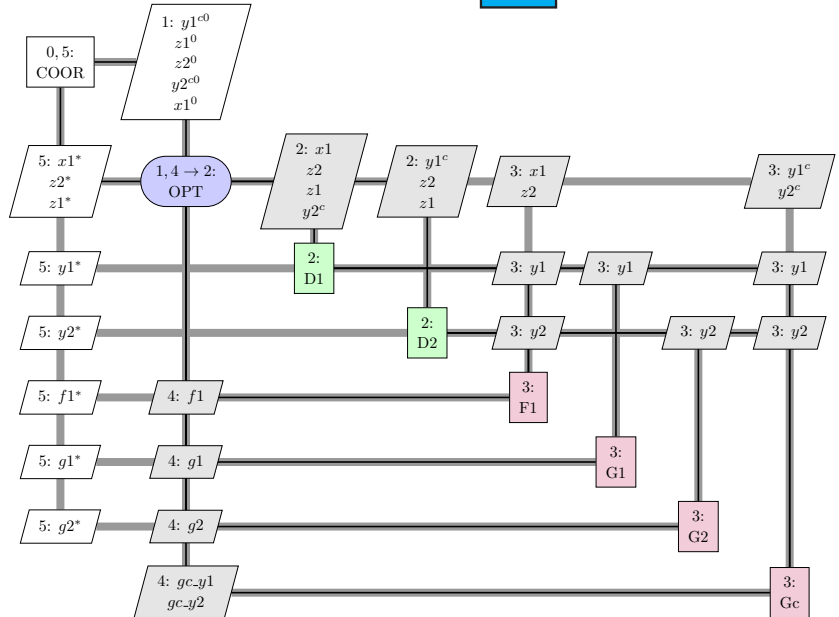

Demo time!

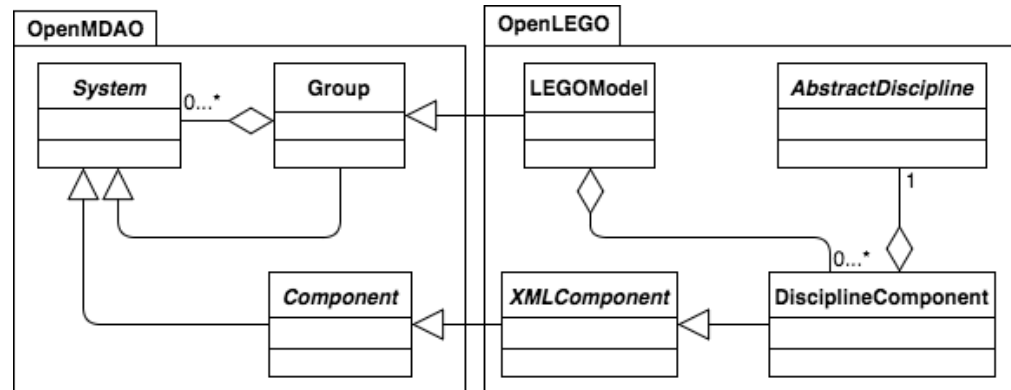

Demo time!

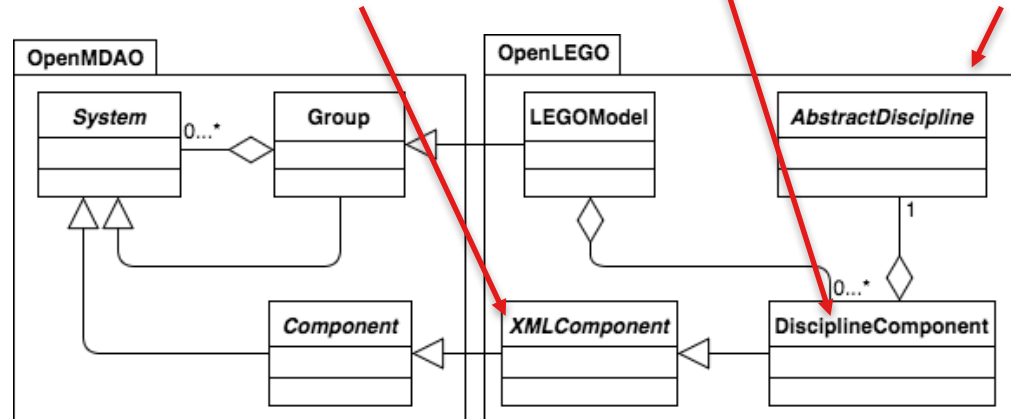
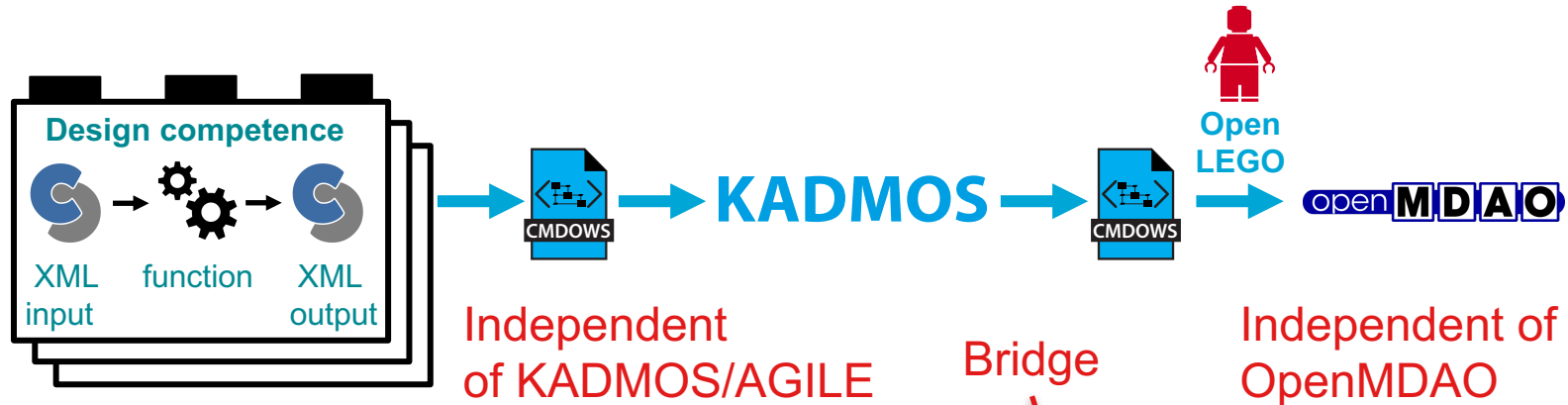

Demo time!

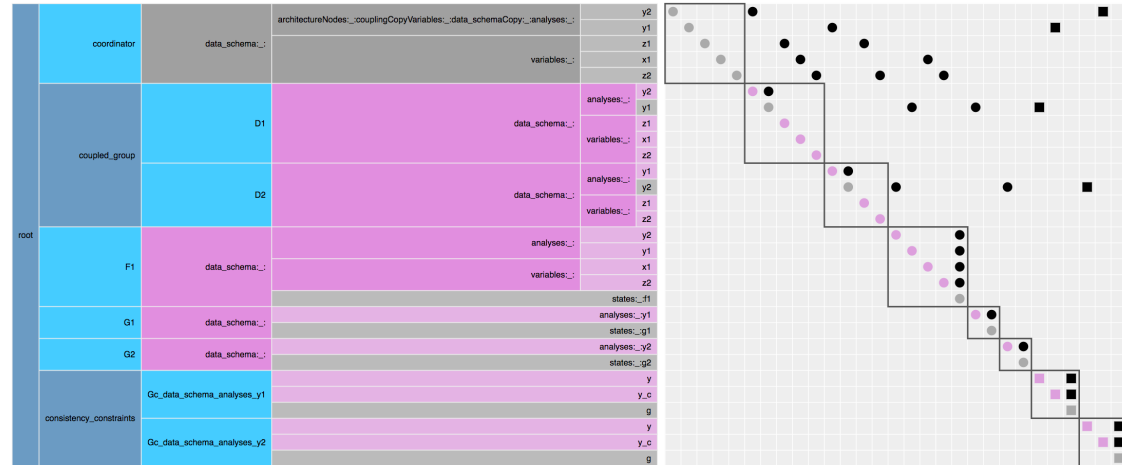
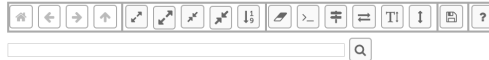
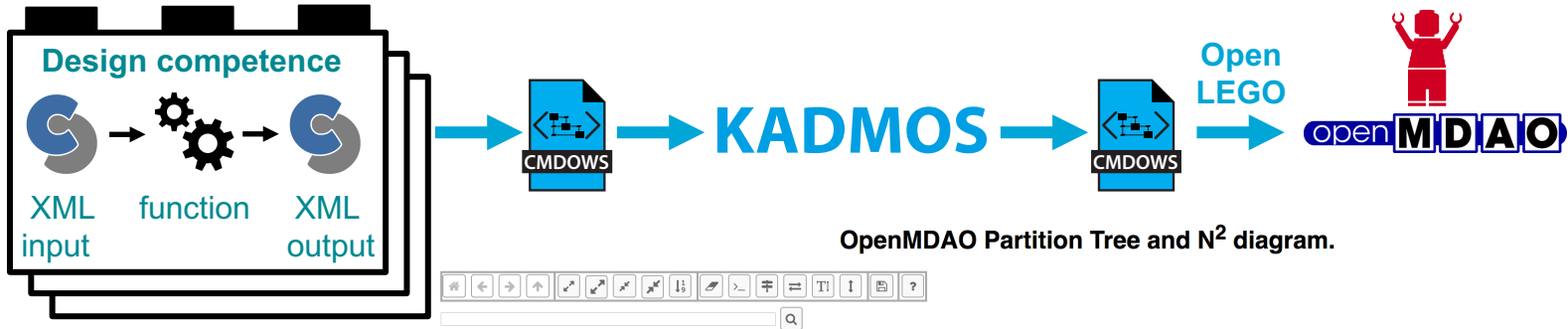

Demo time!

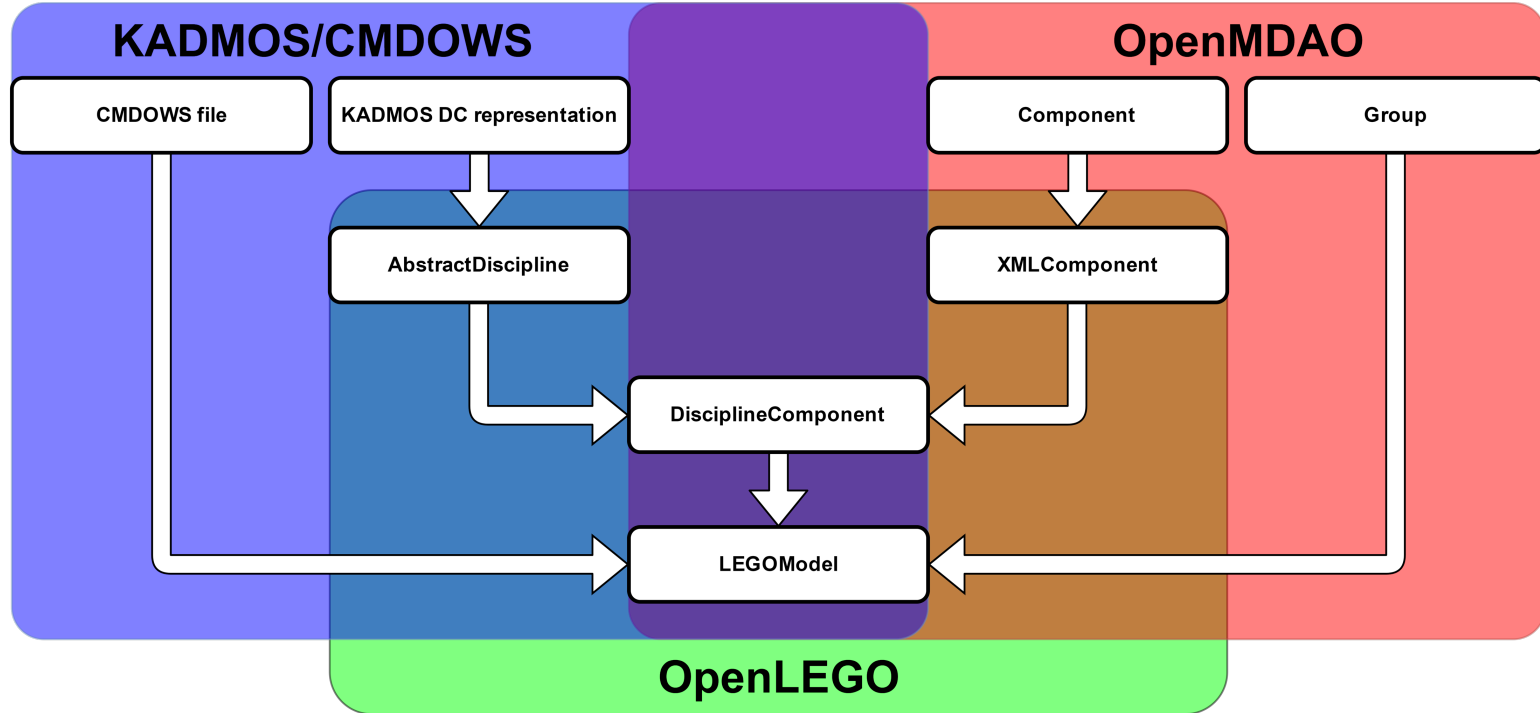

Recap

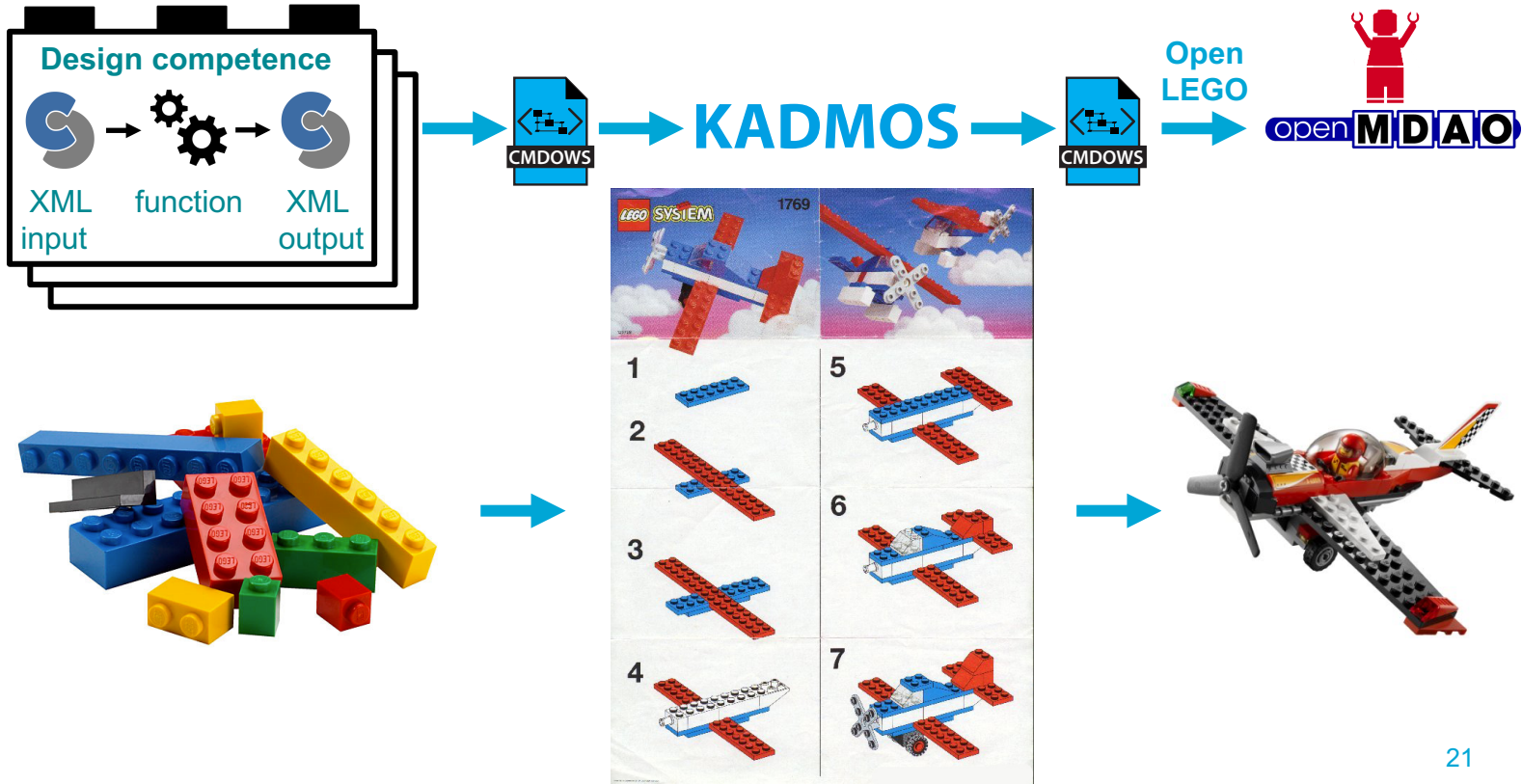

Recap



Benefits:

- High level of reconfigurability and agility
- Scalable in different directions
- CMDOWS modularizes the problem formulation process
- CMDOWS parsers could be an OpenMDAO plug-in

Recap



AGILE Configurations

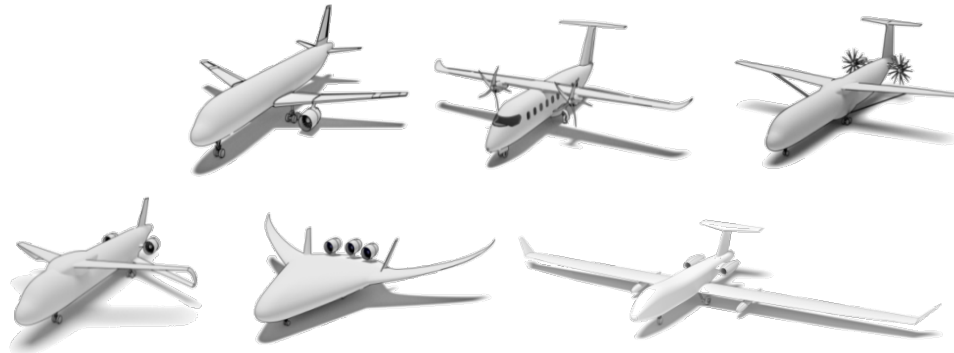

Questions?



Open-source softwares:

- OpenLEGO:
<https://github.com/daniel-de-vries/OpenLEGO>
- CMDOWS:
<http://cmdows-repo.agile-project.eu/>
- KADMOS:
<https://bitbucket.org/imcovangent/kadmos>
- OpenMDAO:
<https://github.com/OpenMDAO>

Acknowledgements

The research presented in this presentation has been performed in the framework of the AGILE project (Aircraft 3rd Generation MDO for Innovative Collaboration of Heterogeneous Teams of Experts) and has received funding from the European Union Horizon 2020 Programme (H2020-MG-2014-2015) under grant agreement n° 636202. The authors are grateful to the partners of the AGILE consortium for their contribution and feedback.

Back-up slide: OpenMDAO 1.7.3

