

HAND_MADE

Architecture
for
craftsmanship

P4 Reflection
Marilene de Wit
1518577



INTRODUCTION

Research for this project has been done in different ways. I want to structure this reflection on the relationship between research and design by dividing this in different epistemologies. These can be seen as the different ways of approaching a subject. These different ways of approaching a subject also have other methods that are useful, such as literature research, drawing techniques, interviews, site visits, building models, or target group research. I won't describe everything, but picked a few that I thought would be most interesting and described the methods and results.

First, I will go into typology, what techniques I used and how they reflect in my design. There are a few different methods to this, as you will read.

Then I talk about the different drawing techniques I used in designing my dwellings, because these are very literally different ways of looking at the subject. Some can be seen as phenomenological, while others give other types of information, all very useful in designing.

At the end I reflect on a few other aspects of my research and design.



TPOLOGY:
PLACING MY BUILDING IN EXISTING FRAMEWORKS

Typological research for live-work designs. For this purpose I have read research done by Francis Holliss and Thomas Dolan, who are the two authors that have an extensive research in this field. Besides her books, Francis Holliss has a website that tries to make an effort in comparing different typologies in live-work design. She calls this a 'pattern book'. Her method for this is the shell-and-core principle. She has a standard UK-floor plan of 6.3 by 7.8 meters (some types are longer) of two or three stories and garden. She chooses to place her core on

the top left corner of her plans, and the entrance zone under this, dividing the floor plan in roughly 1/3 of functional area and 2/3 of area that can be changed per type.

I have reviewed all these types and came up with these diagrams to explore how her dwelling types relate to mine.

I used several drawing techniques; a 2D diagram, an axonometric view and as a conclusion a combination of the two.

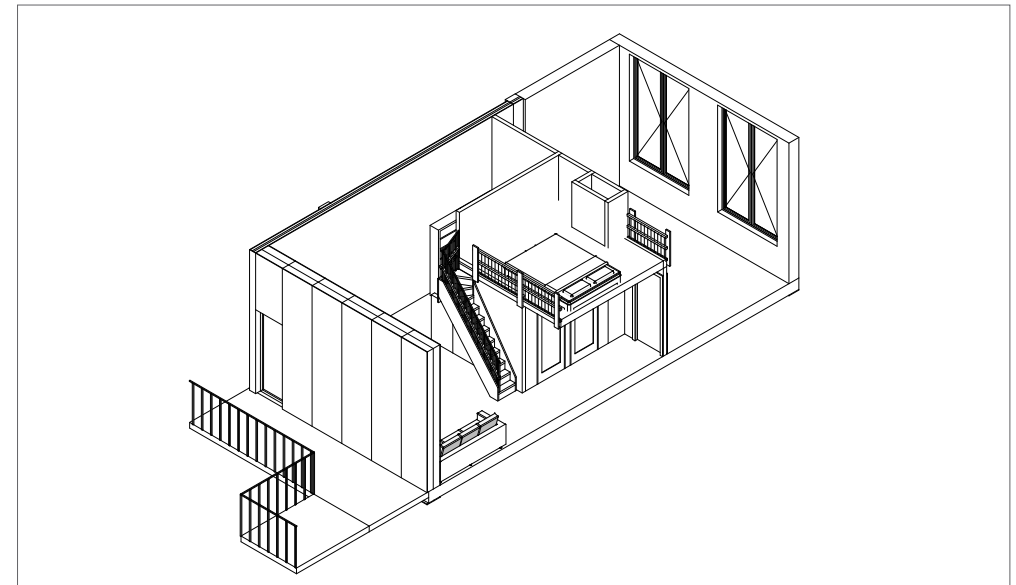
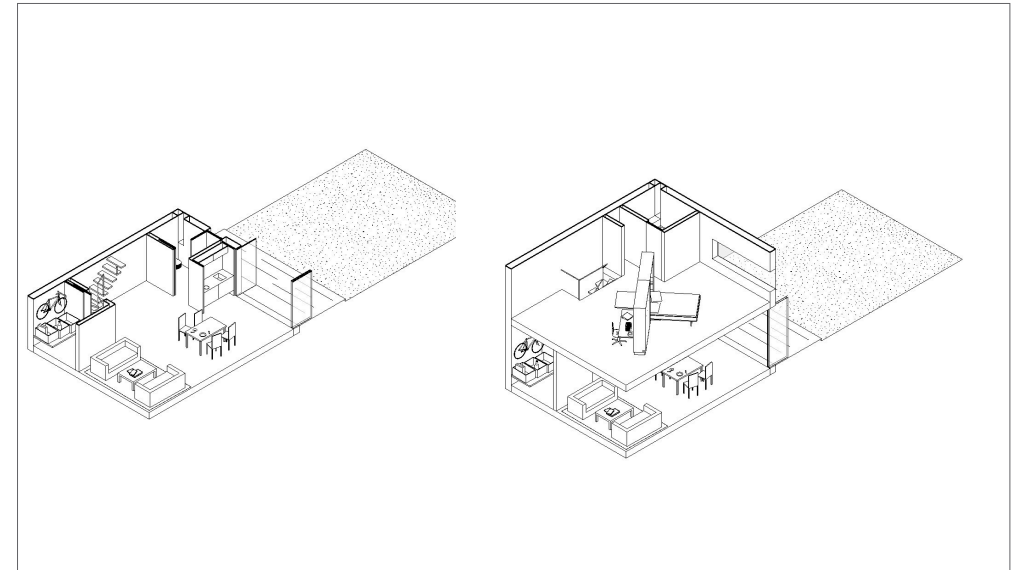

The elements that are drawn in the diagrams are the shell, the core, the entrance, the functional zone, and measurements. These are the constants.

What is then different are the different ways of approaching the rest of the space and how this relates to different types of live-work dwellings. Each other use is linked to design principles, such as dominance of work over living, how private or public the workspace is, types of workplace, patterns of use, user groups, flexibility and adaptability, and other design principles. Out of

combinations of these factors come the types, or the way the floor plans are designed, but the shell and core principles stay the same through these types in order to compare them.

In order to place my design and research in line with Frances Holliss I made the same analytical drawings for my design. This uncovers the relationship between the elements of the core, the remaining space, and the possibilities of how this space can be used.

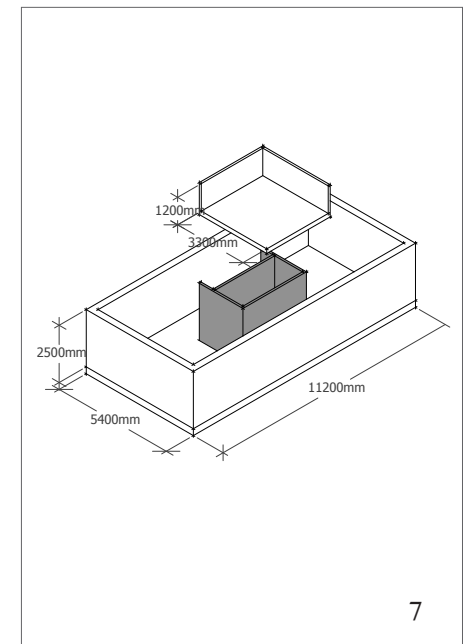
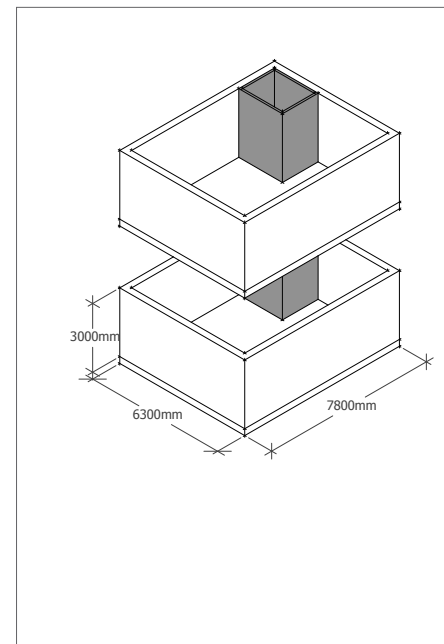
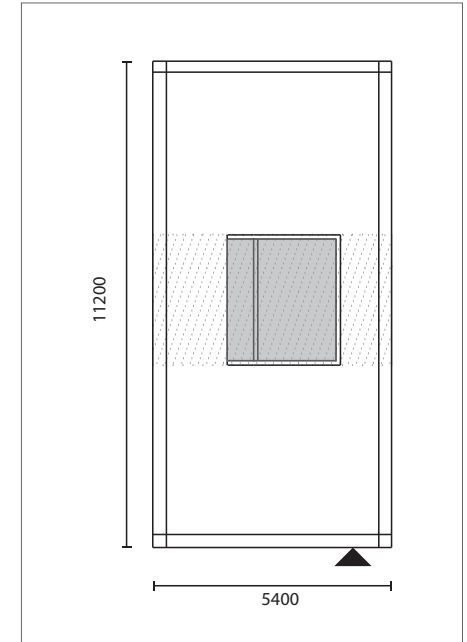
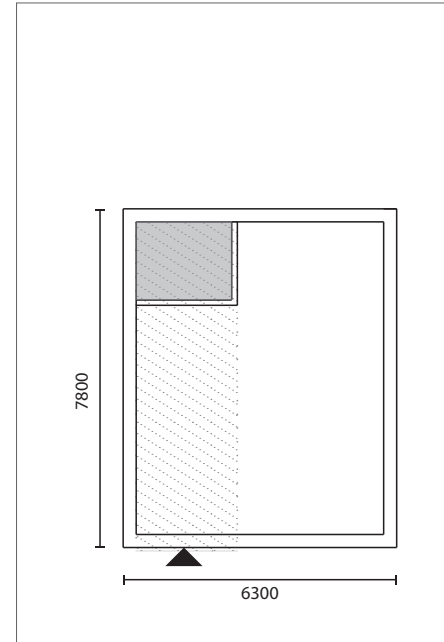

Another way of approaching the typology of live-work design is to not use a certain type of dwelling with physical dimensions but to group types based on the relationship between living and working.

Frances Holliss also does this, for example by the design principles such as dominant use and patterns of use, but Thomas Dolan uses proximity types.

I used this classification as well in my designs, basing the layout of my dwelling types on this.

The first drawing shows the diagrams from the book of Thomas Dolan, and below the section of my dwelling, indicating in red the workspace. The use

can be changed, but this is the way that I envisioned the use and the way that I drew it in my main floor plans.

The studio uses the live-with typology. This is a typology that envisions a dwelling as one large space, combining the main living space and the main working space together without enclosure.

My studio dwelling falls in this typological classification. It is a small space of 30m² with a small loft on top where you can sleep. The rest of the dwelling is an open floor plan where you have your living room and workspace together.

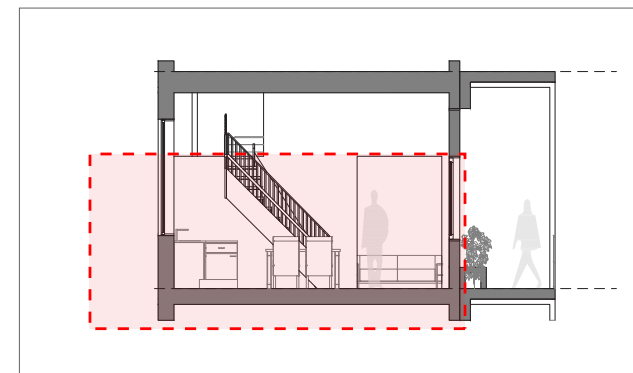
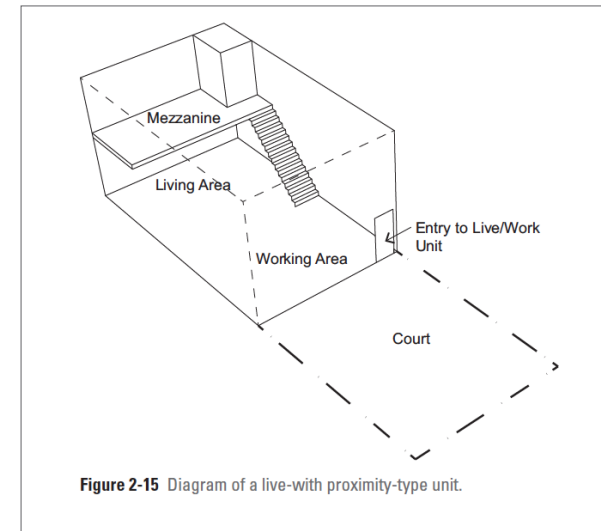

The live-near proximity type translates for me in two dwelling types. The first is the loft apartment, and the second the shophouse. Both have a space that can be closed off from the rest of the dwelling, either by a vertical wall, or horizontal floor. Both are, in the typological classification of Dolan, a live-near type. Both are also designed with the same 'shell and core' principle, I explained earlier, with high ceilings and a loft on top of the functional core for sleeping, making the floor plan flexible in use and future redevelopment.

Another typological classification is the live-nearby dwelling. This implies that there is a short walk included from your home to your workplace. This is for me not a separate dwelling type, but is done in the form of the collective workspaces on the ground floor. Each dwelling can be turned into a live-nearby type if needed.

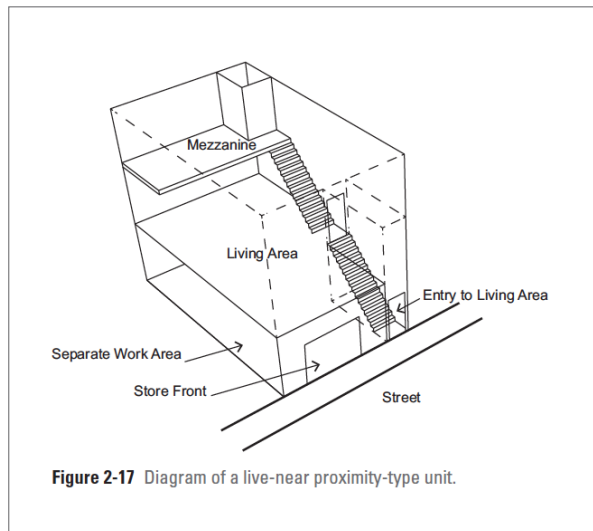
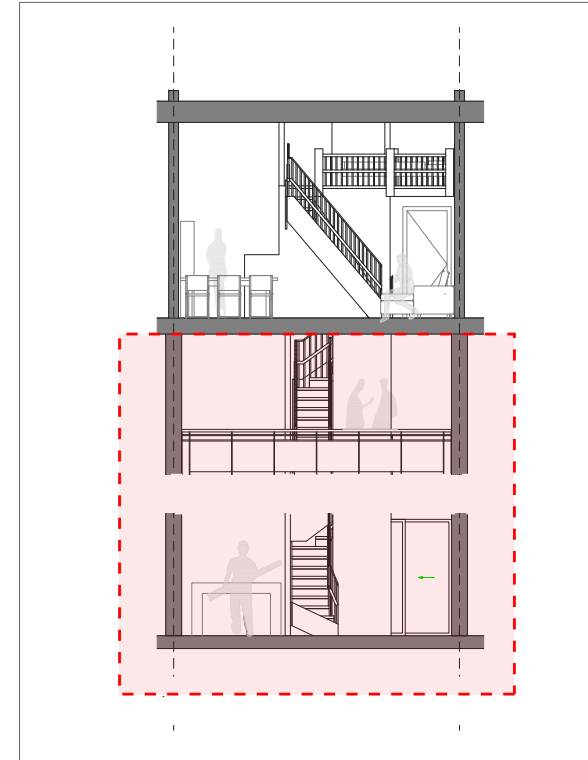
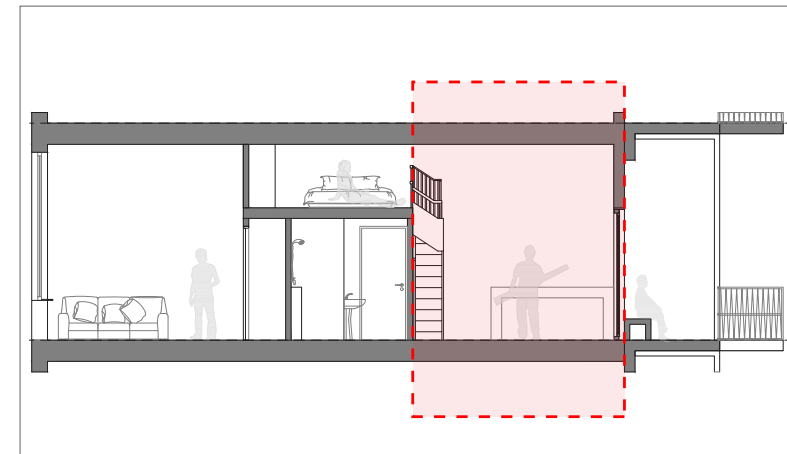

Figure 2-17 Diagram of a live-near proximity-type unit.



TYPOLOGY:
CASE STUDY

Another method I used for researching live-work typologies is the case study.

I researched multiple projects, but the most elaborate one is the Schiecentrale 4B building by Mei Architects.

I found out many interesting things that helped a lot in my understanding of flexible buildings, but there are a few conclusions that were extra relevant for my own design. Actually the analysis of this building was a big influence on my graduation project. It looks as a simple project when you first look at it, but by doing analysis it became clear that getting this amount of clarity in the project is actually very

complex.

On the right you can see one of my analysis drawings of the Schiecentrale, which is the layout and dimension of the functional core of the dwelling. I then looked at how this could be implemented in my own design and how to make this core more efficient, and useful in my smaller floor plan,, which is almost 30m2 smaller than the smallest Schiecentrale dwelling. The result is on the right.

The placement of the core then decides for a big part the flexibility of the building and the limitations. You can see those analysis drawings under each other.

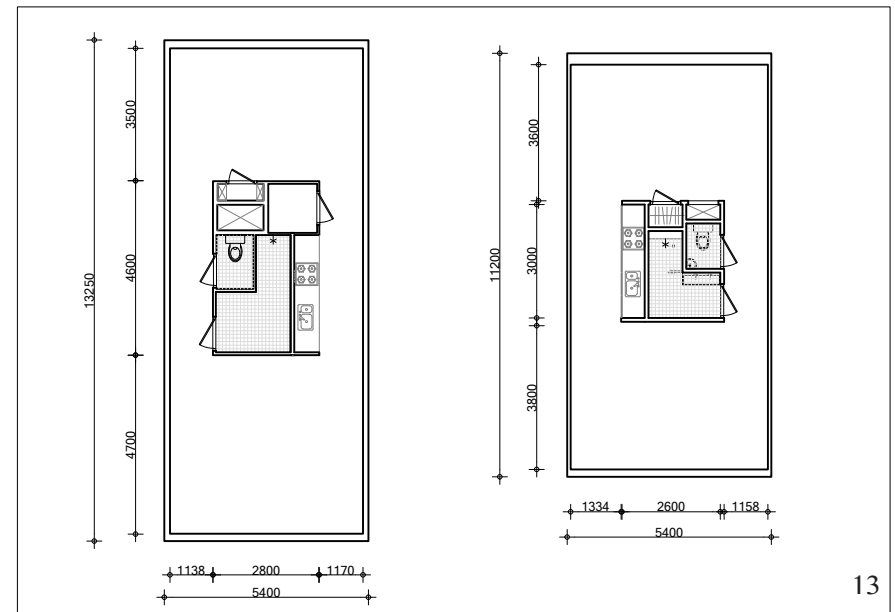
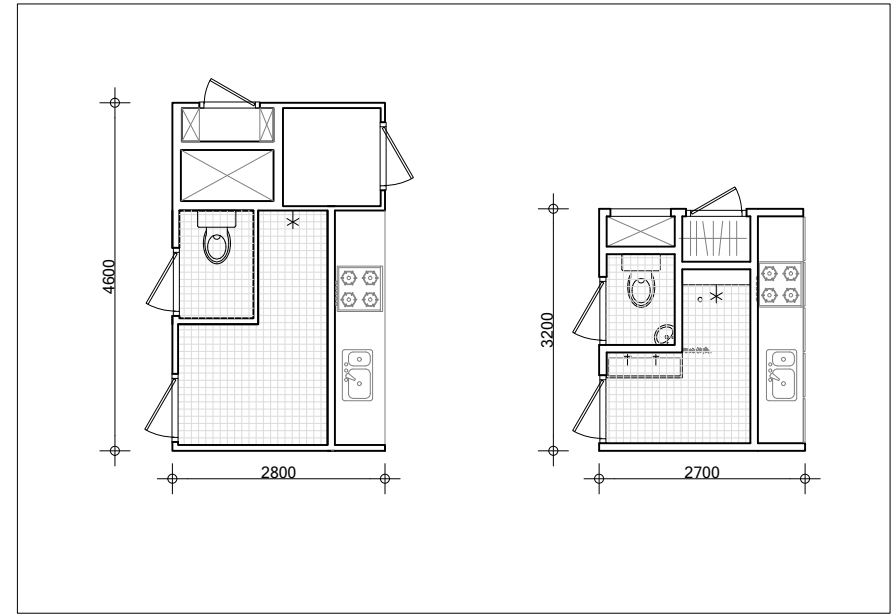

The placement of the core then decides for a big part the flexibility of the building and the limitations.

You can see those analysis drawings under each other. On top the flexibility drawing of the Schiecentrale, under it my design.

The difference is that for me, 6

dwelling can become 4, while in the Schiecentrale the sizes can become different also without taking out a dwelling. For me this wasn't possible because the dwelling would become too big for what I wanted to achieve in terms of affordability.

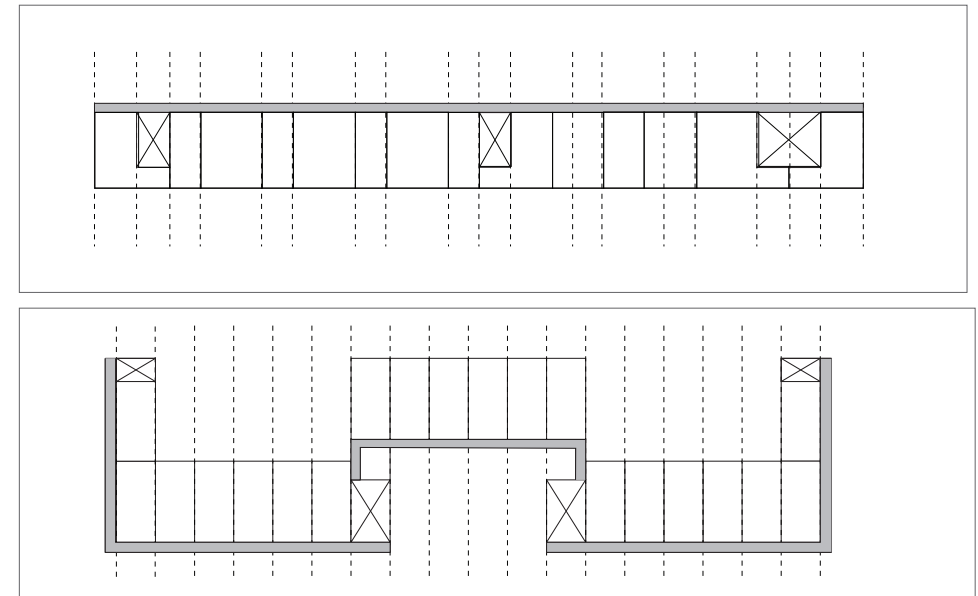
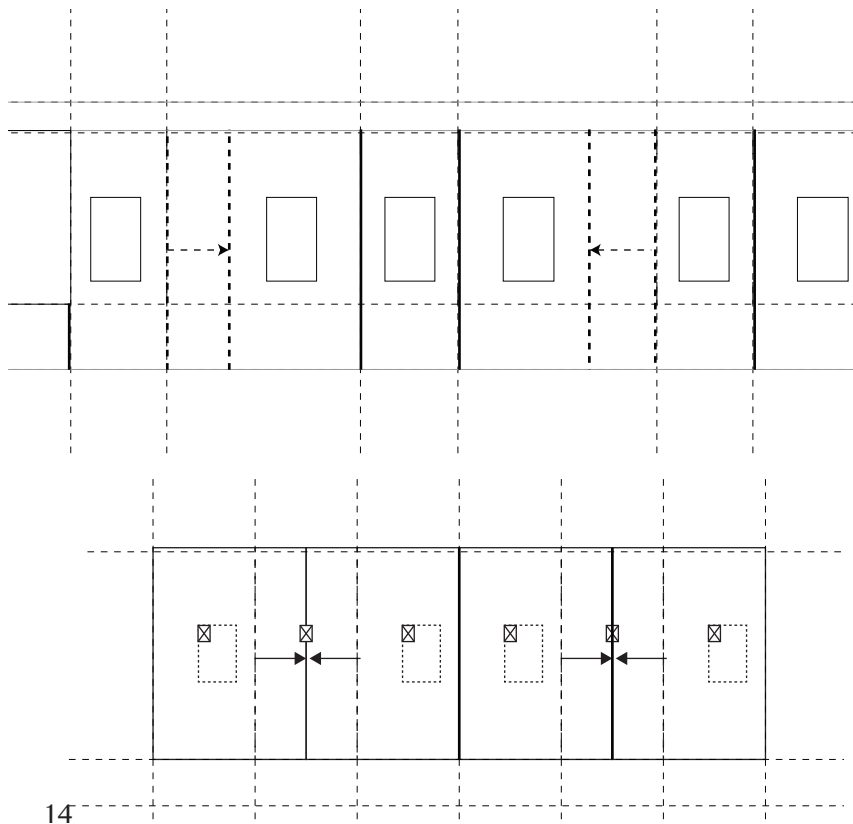

In these diagrams I have analyzed the building principle of the Schiecentrale and applied it to my own building shape. An earlier version of this diagram was a big point of discussion during my P2 presentation. This updated version shows the concept of the flexible dwellings next to each other, with the stairs/elevators and gallery access, which is an effective principle for a flexible building.

DRAWING TECHNIQUES

When designing my floor plans, I first did this in the most common 2D views. After some time I switched to other drawing techniques, to be able to view my dwellings in different ways. All drawings showed other qualities and/or issues that are more obscured in other views. I used the constant switching between these techniques to come up with my final dwelling designs.

This particular technique depicted on the right was very useful for me. It is a perspective section on eye-level. It shows more information, the dwelling in total, than a regular eye-level view would do. It shows in one drawing, both the experience when entering a dwelling, and the relationship with other elements.

I repeated this technique throughout the building

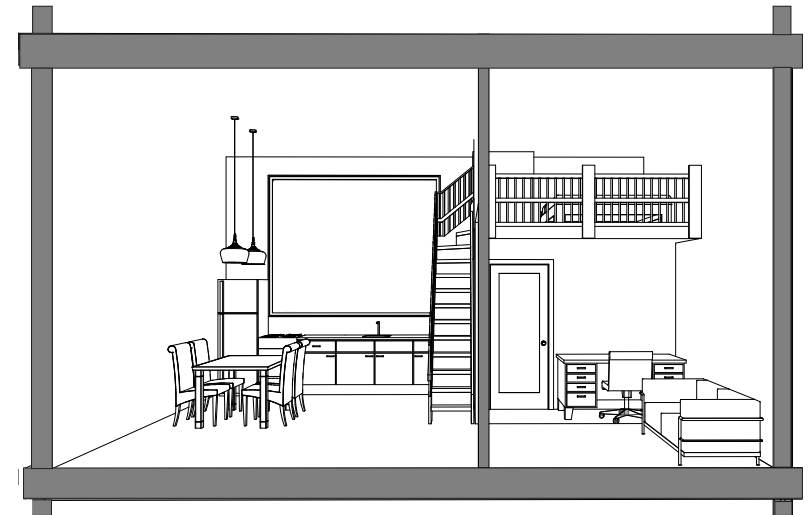
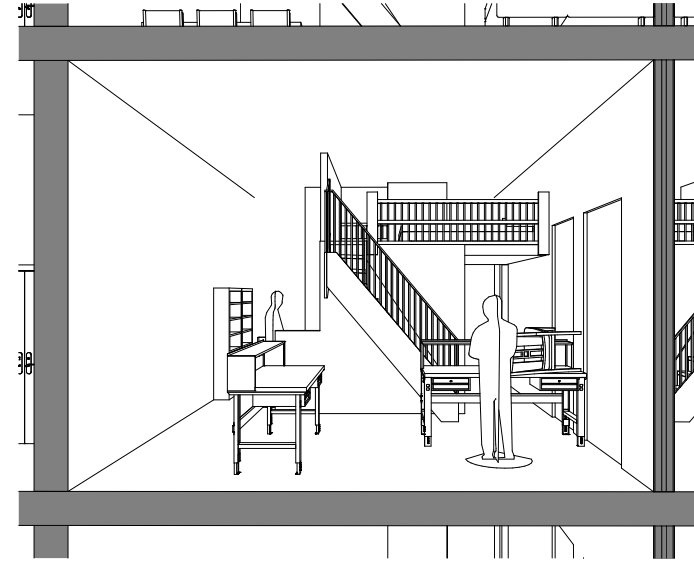

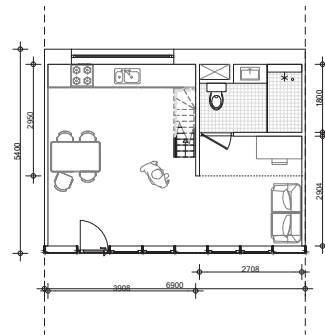
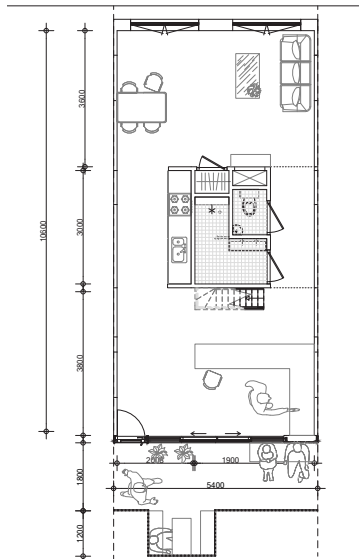
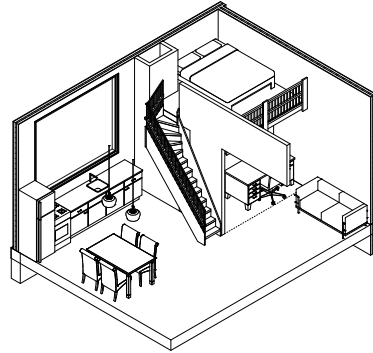
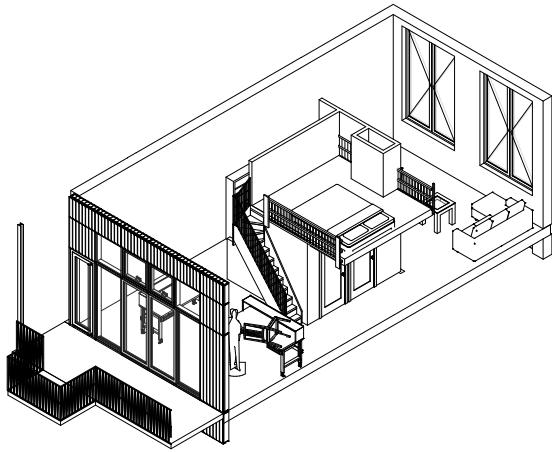

Other drawing techniques I used are the plan view, the section, the axonometric view and the eye-level regular view.

For the plan view the different scales are also very useful, from showing only the structural elements versus the layout of the dwelling, or showing furniture to get a better grip on how the space is used and what dimensions you want.

For drawing furniture, you don't only draw the furniture itself but also the space around it you need to use it in a comfortable way. There are several studies

done about the use of space and furniture, and I used these studies in my design.

When designing you need to switch constantly between what dimensions you want to be able to stack and connect you dwellings resulting in a building scheme that works well, and the dwellings themselves drawn with furniture.

The two results are in the beginning (for me) in conflict with each other and a big portion of the design task went into making them both work in the best way possible.

REFLECTION ON DWELLING DESIGNS

I find flexibility a difficult subject.

Mainly because it becomes chaotic when you don't work in a structured way. For example, it's hard to explain to others what different floor plans mean.

Is it a new type, a variant, or just research into what is the best layout? In order to structure my own thoughts, and also as a way to explain to others what is what, I made this diagram.

On top is the principle I used, that of the shell and core. Below that are the dwelling types, 3 in total. Then the adaptability, for example the 5.4 bay width

dwelling becoming a 8,1m bay width dwelling. Under that are the different variants, ways in which the floor plan can be used by the inhabitants. The last two are two different types of flexibility.

One is the flexibility in the design phase or re-use phase, while the polyvalence is the user flexibility.

These two are fundamentally different and should therefore be distinguished from each other.

I came up with this diagram more towards P4. I think that if I had these earlier, it would have helped clarify the project during my P2 and P3.

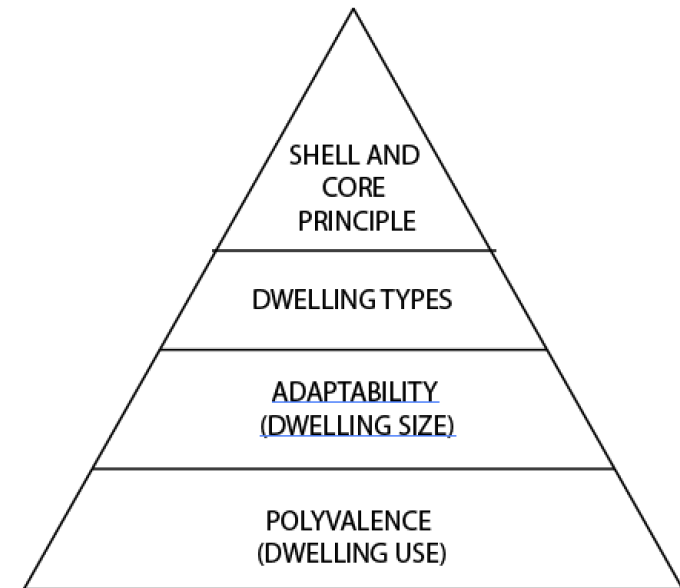

RESEARCH SUBJECTS

I tried to reflect on the coherence between my different subjects of research by drawing this diagram. Every big circle is one of the topics of my project, and where they touch each other they translate into more concrete

the end they come together in my building, which are the 2 triangles at the middle. It is a live-work building that is future oriented, and my design process the arrow that tries to connect these two into one design.

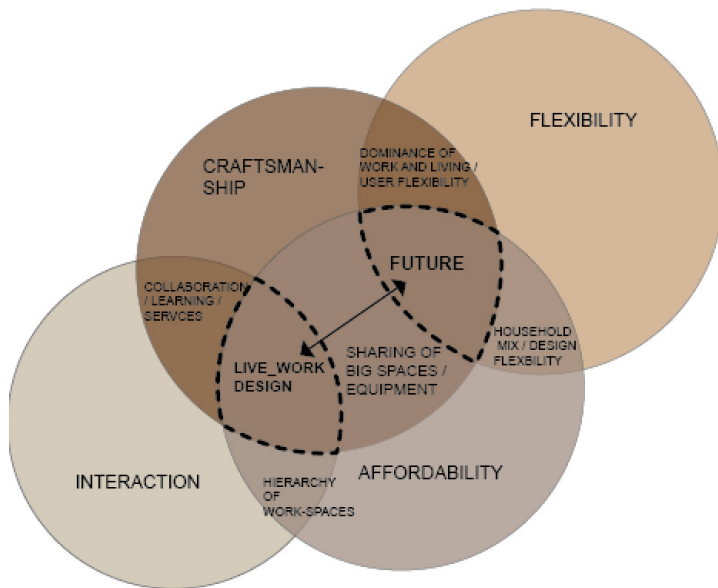

RESEARCH AND FINAL DESIGN

Much research is now nowhere to be seen in the final design. I think 90%. It ranges from things you learned from literature review, case studies, design studies, and many other kinds of studies. I think most of what we did for the last year could be qualified as some sort of study. But when looking at your final products, it becomes clear that you can draw an entire set of drawings in a limited amount of time of you're skilled. So most of the work wasn't the final products, but everything behind it. How you came to the conclusion that are your final drawings in a way, is the process. And in this process about 90% of

what you do does not get shown in your presentations, or even the meetings you have with your tutors.

I want to clarify by using a few examples.

1. Studies into how things can be done, and then choosing the best variant of a design series
2. Making big (design) decisions in one aspect influences all other aspects, sometimes resulting in that you can throw away something you were enthusiastic about, such as complete dwellings types, or the form of your building.

RELATIONSHIP BETWEEN PROJECT TOPIC, STUDIO
TOPIC AND MASTER TRACK.

As described more elaborate in the graduation plan, my research and design focus on the topic of living and working, or more specially, live-work design for craftsmanship in the city center of Amsterdam. The design focuses on future developments. During the P2 period I investigated the developments and prognoses for the future related to the topic of living and working. It was one of the conclusions that the number of freelance workers will increase, and that these people prefer to have a workspace in or close to home. There is then a list of benefits and what this means for the city and the city center. and

This conclusion was the basis for my project topic. As a target group I investigated what the city needs (in the future) and what people need. It was one of my findings that craftsmanship is disappearing from the city, especially the city center. Attached to this conclusion is a scenario of what it will do to a city and its culture when craftsmanship disappears. The group that is most in need of space are, logically, the professions that need much space to be carried out. I have investigated and designed the possibility of making parts of this profession partly carried out in a collective workspace that reduces

the pressure of needing a lot of space per person, while at the same time encouraging collaboration and a revaluation of crafts in our culture in order to save it.

The studio topic was a designing a project that densifies the city center of Amsterdam around the Singelgracht, the old fortification belt of Amsterdam. The design needs to be future orientated. I tried with my topic and design to connect to the studio topic of being future orientated by designing a building that is flexible in multiple ways. This way, the building can change when ideas about the relationship between living and working also change. There are multiple types of flexibility in the project, such as user flexibility (the layout of the floor plan), but also other future uses (other dwellings sizes, and the ratio between living and working in the project). The structure, layout, access type and facade make

these future changes possible. This way I think the functional life-span of a building that is still young in typology can still be very sustainable in the most basic meaning of the word.

I chose a location that is both suitable for my project topic, which has a lot to do with craftsmanship and small businesses, but is also in the city center of Amsterdam. From a historic perspective, this location was always used for small industry and business, while in current day it is still one of the only undeveloped areas in the city center of Amsterdam. The topic of live-work design is future oriented because the conclusion that our current ways of separating all our activities is not sustainable when our cities expand and densify. I tried with my research and design to add to the topological research already done in this field.

ELABORATION ON RESEARCH METHOD AND
APPROACH CHOSE BY THE STUDENT IN RELATION
TO THE GRADUATION STUDIO METHODOICAL LINE
OF INQUIRY

Literature research was where I started my research, finding the most relevant literature for architecture and urban planning on the topic of live-work design. This consisted of more theoretical information, in the forms of books and many articles, as well as topological researches and reading of other successful designs on this topic. A few interesting cases I then worked out in case studies, giving me more detailed information on how to translate all this information into a design. The more topological studies I then translated into my own design, trying to reflect on how my design was different or the same from the topologies already developed by others. I have further elaborated on this point in aspect 1.

As a Dwelling graduation student, the main focus of the research is on the relationship between architecture and urban context, on the architectural design of our everyday living environment and housing. Within the Dwelling chair, the importance of research and knowledge in type and typology is emphasized. The focus is on designing dwellings and our mentors discussed with us that there is such a wide variety of

systems on building scale as well as dwelling scale, and that everything has already been done before, so knowledge of precedents is crucial. In the last months we developed knowledge in this research method through our graduation project. We are encouraged to think in schemes and relationships. For this purpose, you first need to know how you get to the core of a design through analysis. This why topological research through for example case studies in important.

In my design I relied on two types of typological research. One was through case studies of relevant project that were more recent. The other was by reading and analyzing the attempts of others to develop typologies for live-work design, such as Frances Holliss and Thomas Dolan, and then seeing how these typologies could be used as a possible fundament for my own design ideas.

ELABORATION ON THE RELATIONSHIP BETWEEN THE
GRADUATION PROJECT AND THE WIDER SOCIAL, PROFESSIONAL
AND SCIENTIFIC FRAMEWORK, TOUCHING UPON THE
TRANSFERABILITY OF THE RESULTS

It was surprising for me to find how little information there is actually to find on the topic of my research. The integration of living and working is a very actual and important topic, but for some reason the research is still very young. As said before I investigated the work of Holliss and Dolan. I then tried to put my work in the perspective of their work, by making diagrams that show the (dis)similarities between the design approaches for live-work design. The principle for my own design also rely heavily on conclusions from one of my case studies, the Schiecentrale. I then applied the synthesis of all these

conclusion in my own project, and then drew diagrams to analyze them again from this typological perspective. This gives the designs of the dwellings themselves some research value that could be interesting for others that have a similar topic and design approach.

THE ETHICAL ISSUES AND DILEMMAS
ENCOUNTERED IN DOING THE RESEARCH,
ELABORATING THE DESIGN AND POTENTIAL
APPLICATIONS OF THE RESULTS IN PRACTICE

I have lived in Amsterdam all my life, appreciating the city and its beauty. One of the things that I find charming about the city center of Amsterdam is that the buildings have a small grain size and are not very high. But when researching building projects that should densify the city center it is an ethical dilemma if you should make high buildings to make more dwellings and make the city center accessible for more people to live in, making it more inclusive, or if you want to keep the old charm of the city with the lower building heights, which also means less dwellings. So you have to decide what is more important;

maintaining this old charm or making the city more accessible for everyone in the future. Also, on my site, I chose to demolish the existing buildings. Partly because they are old and not very well maintained, but whenever you decide to demolish something it is in my opinion always an ethical dilemma. What is valuable and what is not is very subjective and should always be investigated carefully. This step of deciding what should be demolished is in practice a much longer process than it was in this graduation project.

