

# Shock Safe Nepal

**TEAM 5**

Micky Schepers  
Alexandra Widjaja  
Focco Vons  
Floris Sijbesma  
Emanuele Rossi



# Shock Safe Nepal

## TEAM 5

Micky Schepers  
Alexandra Widjaja  
Focco Vons  
Floris Sijbesma  
Emanuele Rossi

Academic board

Drs.ir. J.G. Verlaan  
Dr.ir. M.G.C. Bosch-Rekvelde  
Dr.ir. H.R. Schipper  
Dr.ir. E. Mosselman  
Prof.dr. W.M. de Jong

October, 2017  
Delft University of Technology







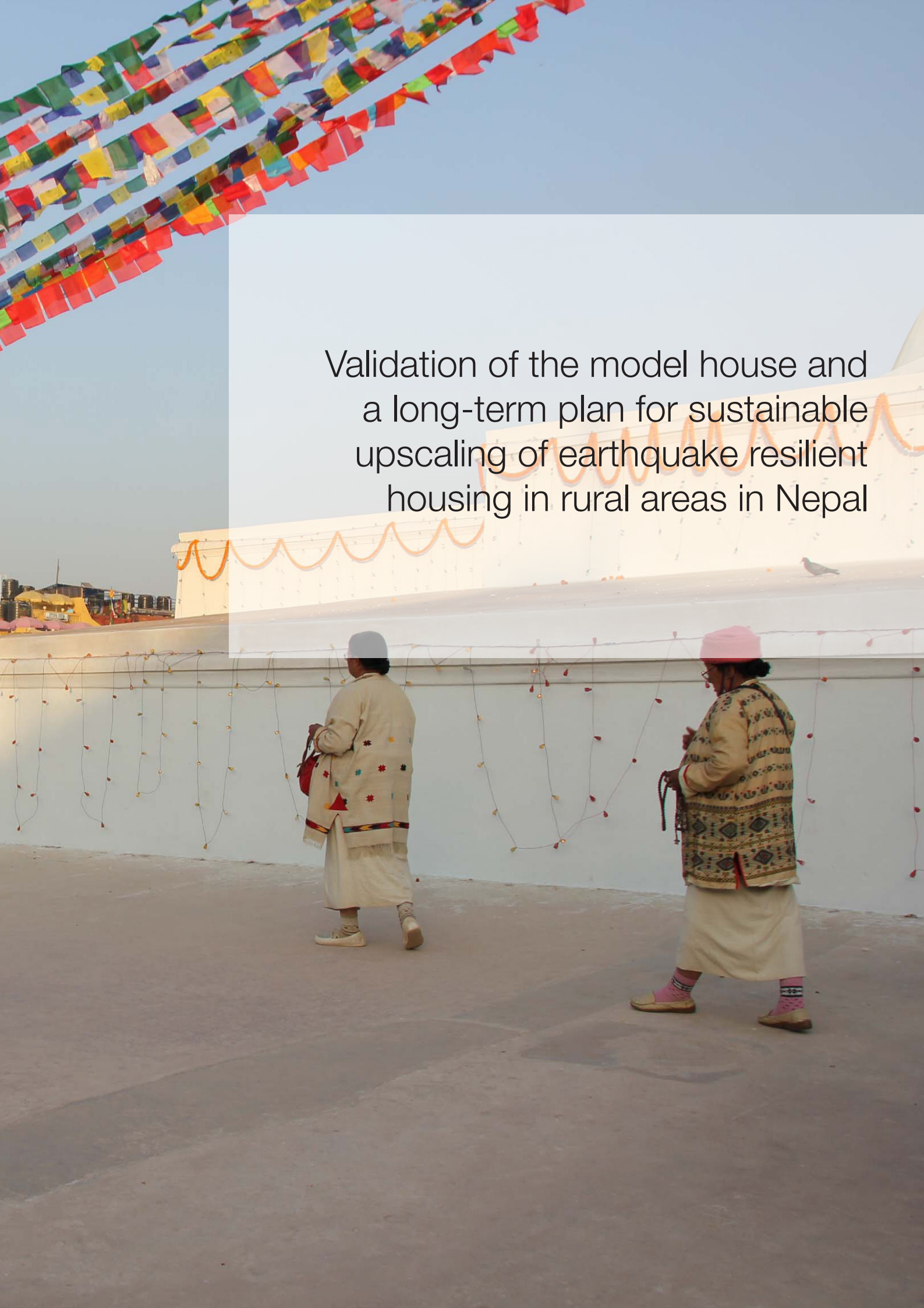

Validation of the model house and  
a long-term plan for sustainable  
upscaling of earthquake resilient  
housing in rural areas in Nepal

## Partners of Shock Safe Nepal team 5







# Disclaimer

This report was written by students of TU Delft as a partial fulfilment of their Master's degree, the report being the final deliverable for the course CIE4061-09 Multidisciplinary Project. This project is part of the student learning program, therefore the students are not obligated to achieve any specific results outside the scope of this particular educational project. Although the content of the report was written with care by the students and read and graded by TU Delft tutors, all readers should be aware that neither TU Delft nor the students can be held responsible for the use of the report or other student's results outside of this educational scope.

# Foreword

After the earthquake in Nepal of April and May 2015 large parts of Nepal were devastated. The catastrophic force left over half a million Nepalese homeless and over three-quarters of a million homes were damaged. After this earthquake, the project Shock Safe Nepal was initiated, a Multidisciplinary project of the initiated by students of the TU Delft which focused on providing a technical research platform around rebuilding an earthquake safe Nepal and striving to contributing to the quality of reconstruction in Nepal. It is undeniable that another earthquake will hit Nepal in the future but the only uncertainty remains when this will happen. It is of great importance that houses are rebuilt efficiently and affordably, but above all they need to be earthquake resilient. Since then 4 teams have taken part in the project, we are the fifth team. The design of a pilot building that the research of the previous teams led to was constructed by the 4<sup>th</sup> team in the village of Ratankot. This design and building has been the base of our report.

In February 2017, we left the Netherlands to spend 2.5 months in Nepal doing research. Team 5's mission was technically validating and structurally optimizing the current design regarding earthquake resistance. This consisted of determining the material properties of the used materials, structural calculations and ways to optimize the design. From a house seen as a validated black box, the upscaling possibilities of the design were explored. Large scale implementation of a design would be easy if the only issue was the design, however there are of course an enormous amount of aspects that must be considered when aiming for this. This analysis of the context can be used by future teams.

We wish the following Shock Safe Nepal teams and all other organisations involved in rebuilding of success.

Alexandra Widjaja  
Emanuele Rossi  
Focco Vons  
Floris Sijbesma  
Micky Schepers

Delft, September 2017

# Acknowledgements

We are grateful for the following organisations and people for their help in the making of this project. Without their help this project would not have been possible.

First, we would like to thank Drs.ir. Jules Verlaan, Dr.ir. Roel Schipper, Dr.ir. Sander van Nederveen, Dr. ir. Marian Bosch-Rekvelde, Dr.ir. Erik Mosselman and Prof.dr. Martin de Jong for guidance and supervising at Delft University of Technology. Furthermore, we would like to thank Brecht de Mey of Support4Nepal, Karma and Shiam Lama and previous teams of SSN in preparing us in our research by sharing knowledge on Nepal and the Nepalese construction industry.

In addition to the support from The Netherlands, we are grateful to also have received help in Nepal. We would also like to thank Siobhan Kennedy from HRRP and Salena Sangachhe from Architecture sans Frontières for their input and knowledge sharing while we were in Nepal. Special thanks go out to Cheryl Groff and her team from Habitat for Humanity and Andreas and Bjorn from Build Up Nepal for their ongoing support while we were in Nepal, and their help in getting to understand such a complex situation.

Finally, we would also like to thank DIMI, Delft Global Initiative, FIS fund, Students4Sustainability and StuD for their financial support.





# Executive Summary

Shock Safe Nepal was founded as a response to the 2015 Nepal earthquakes to function as a platform to contribute to the development of knowledge on earthquake safe housing. The goal of the report of team 5 is to validate and optimise the design of the pilot house that was created based on the work of previous teams, and the development on implementation plans for a validated and optimized house. Literature study, field work and interviews have been performed resulting in main findings of this report.

Primarily, the used materials were analysed in the report, including bamboo, CSEB bricks and concrete. They were analysed consulting literature, conducting laboratory tests in cooperation with the University of Tribhuvan. Bamboo was mainly analysed consulting literature sources, since laboratory tests were not feasible. It was found that its material properties are immensely difficult to determine and can vary from one column to another. However, it remains a strong and cheap building material. CSEB bricks were used due to its availability, strength and price. The material properties were derived from tests done by Build Up Nepal and from literature sources. Its mechanical performance is like that of concrete. It's an easy material to build with and incorporate steel rebar's. However, its durability and consistency is something which was not thoroughly investigated and remains debatable. The concrete used, was thoroughly tested, conducting slump cone, compression and Schmidt Hammer tests. It was found that the concrete used in the pilot house is of acceptable quality, but there is room for improvement by following clear guidelines and technical assistance.

Subsequently, static calculations were executed, regarding the roof, the load

bearing structure and the foundation. It was found that these different components, perform safely under static conditions, with the applied loads, separately and combined. The load bearing structure has turned out to be a wall-bearing structure. This was not assumed at first. Furthermore, after calculations, it was found that the roof and foundation were largely over dimensioned. This is, however, determined considering many assumptions, such as the soil properties.

Regarding an earthquake situation, the walls and bearing capacity were researched and calculated following quasi-static conditions. The earthquake conditions were derived from the Peak Ground Acceleration. Primarily the walls were researched. Two scenarios were considered, a 3-point collapse failure mechanism and punctual overturning collapse failure mechanism. Both mechanisms were tested for different wall compartments. These calculations give a small insight in the actual situation, because dynamic loads are applied statically, non-linear or dynamic calculations should be conducted as well as FEM modelling, for more thorough understanding. It must be said that the rebar and resonance effects were not considered. Regarding the bearing capacity, a PGA of 0.6 was used and from calculations, partly considering the soil and superstructure inertial effects, the bearing capacity would not fail. However, superstructure resonance was not considered. Larger PGA's were not investigated, which means that it is not determined under which conditions failure would occur.

From these analyses the Structural optimizations are made to the design. This includes improving the joints between different elements of the house. Regarding the materials used the optimisations include

protecting the CSEB bricks from weather as they are loadbearing. Guidelines are given on the placement of the house regarding the foundation and the slope. According to the calculations the foundation is over-dimensioned.

For the stakeholder analysis, extensive research was done through interviews which was combined with literary information available. This was then used to create a power interest grid and a network analysis, which shows the links between different categories of stakeholders and different specific stakeholders. This analysis also gave insight in the sheer number of stakeholders involved in rebuilding Nepal and the importance of defining the role of SSN further.

The external factors that are important in working in Nepal were analysed, this was done regarding social, technical, economic, environmental, political, legal and ethical aspects and based on literature research, field research and interviews.

Implementation methods of different types of organisations in Nepal were analysed. These findings were concluded in a SWOT analysis of the organizations. Defining the strengths, weaknesses, Opportunities and threats of other organisation help to define the direction that SSN should move in and those aspects of building in Nepal that can also be defined as strengths, weaknesses,

opportunities and threats to SSN or make SSN different to other organizations.

The risks of building in Nepal must be considered to create a realistic and feasible long-term plan and need to be mitigated a risk analysis is done. The findings in the risk assessment are found in external risks, design risks and construction risks. A plan is then set up to mitigate external risks and construction risks are the

The findings of the Long-term plan are organized into a strategy for SSN, an engagement plan and an implementation pathway. The strategy is concluded in a SWOT analysis which is then used to create a TOWS analysis. This TOWS analysis combined the internal and external strengths and weaknesses to bring new creative ways of maximizing strengths and opportunities and minimizing the weaknesses and threats. The Implementation pathway contains long-term goals for SSN, that are structured into regulatory, implementation, technical and organizational goals and that can be added onto by future teams.

This research is to be a logical step in a series of research projects which will contribute to the reconstruction of an earthquake safe environment in Nepal. It can be used as consultation advice, guideline or as a base for in-depth follow up research on one of the included topics.



# Acronyms

ASF	Architects Sans Frontieres
CSEB	Compressed Stabilised Earth Bricks
CL-PIU	Central Level Project Implementation Units
DGN	District Government Nepal
DIMI	Delft Deltas, Infrastructures & Mobility Initiative
DL-PIU	District Level Project Implementation Units
DUDBC	Department of Urban Development & Building Construction
EWB	Engineers Without Borders
GDP	Gross Domestic Product
GoN	Government of Nepal
HRRP	Housing Recovery & Reconstruction
INGO	International Non- Governmental Organisation
IOM	International Organisation for Migration
KTM	Kathmandu
NCDM	Nepal Centre Disaster Management
NGN	NGO Federation of Nepal
NGO	Non-Governmental Organisation
NPC	National Planning Commission
NPR	Nepalese Rupee
NRA	National Reconstruction Agency
NRCS	Nepal Red Cross Society
NSET	National Society for Earthquake Technology
S4N	Support4Nepal
SSN	Shock Safe Nepal
SWC	Social Welfare Council
TUD	TU Delft
UN	United Nations
UNDP	United Nations Development Program
USD	United States Dollar
VDC	Village District Committee



# Table of contents

<b>1</b>	<b>INTRODUCTION .....</b>	<b>11</b>	<b>5.2</b>	<b>Discussion of Results .....</b>	<b>73</b>
1.1	Background Shock Safe Nepal .....	11	<b>6</b>	<b>STATIC CALCULATIONS ON WALLS ..</b>	<b>74</b>
1.2	Problem definition .....	11	6.1	State of the house.....	74
1.3	Goal.....	11	6.2	Static calculations.....	78
1.4	Research question .....	11	6.3	Discussion of Results .....	87
<b>2</b>	<b>METHODOLOGY.....</b>	<b>13</b>	6.4	Recommendations.....	88
2.1	Scope .....	13	<b>7</b>	<b>SOIL PROPERTIES .....</b>	<b>90</b>
2.2	Inventory.....	13	7.1	Introduction.....	90
2.3	Technical validation.....	14	7.2	Soil classification .....	90
2.4	Long-term plan for upscaling and implementation .....	15	7.3	Discussion of Results and Recommendations .....	94
2.5	Timeline and project phases .....	16	<b>8</b>	<b>FOUNDATION STATIC CALCULATIONS</b>	<b>97</b>
<b>MATERIALS .....</b>	<b>18</b>	<b>8.1</b>	Overview foundation.....	97	
3.1	Bamboo.....	18	8.2	Load determination .....	97
3.2	CSEB bricks.....	34	8.3	Static calculations.....	101
3.3	Concrete .....	37	8.4	Settling and deformations.....	108
3.4	Steel .....	52	8.5	Discussion of results and recommendations .....	112
3.5	Discussion of results and Recommendations.....	52	<b>9</b>	<b>QUASI-STATIC CALCULATIONS.....</b>	<b>115</b>
<b>4</b>	<b>LOADS.....</b>	<b>56</b>	9.1	Acceleration of initiation of collapse mechanism .....	115
4.1	Loads determination.....	56	9.2	Static linear analysis.....	120
4.2	Structural preliminary analysis.....	62	9.3	Conclusions and recommendations	125
4.3	Discussion of Results .....	67	<b>10</b>	<b>PSEUDO-STATIC CALCULATIONS ON FOUNDATIONS .....</b>	<b>127</b>
<b>5</b>	<b>ROOF .....</b>	<b>68</b>	10.1	Seismic acceleration factor .....	127
5.1	Roof calculations.....	68	10.2	Seismic bearing capacity .....	128

10.3	Discussion of results and recommendations .....	137	15	IMPLEMENTATION METHODS....	183
11	<b>MATERIAL OPTIMISATION .....</b>	<b>139</b>	15.2	Habitat for humanity .....	185
11.1	Concrete .....	139	15.3	Architecture sans Frontieres.....	188
11.2	Bamboo.....	140	15.4	Build Up Nepal.....	190
11.3	Steel .....	146	15.5	University of Tribhuvan.....	192
11.4	CSEB bricks.....	146	15.6	HRRP .....	194
12	<b>STRUCTURAL OPTIMIZATION .....</b>	<b>149</b>	15.7	Conclusion .....	195
12.1	Joints.....	149	16	<b>RISK ASSESSMENT .....</b>	<b>197</b>
12.2	General recommendations.....	151	16.1	Identify risks.....	199
13	<b>STAKEHOLDER ANALYSIS.....</b>	<b>153</b>	16.2	Risk strategies .....	204
13.1	Types of stakeholders .....	154	16.3	Conclusion .....	213
13.2	Key stakeholders .....	158	17	<b>LONG-TERM PLAN FOR UPSCALING OF IMPLEMENTING EARTHQUAKE RESILIENT HOUSING .....</b>	<b>215</b>
13.3	Power Interest.....	160	17.1	Strategy for SSN.....	215
13.4	Power Interest Attitude .....	162	17.2	Engagement Plan .....	220
13.5	Network Analysis.....	164	17.3	Implementation pathway .....	222
13.6	Conclusion .....	165	17.4	Conclusion long-term plan & implementation pathway.....	225
14	<b>EXTERNAL FACTORS .....</b>	<b>166</b>	18	<b>DISCUSSION .....</b>	<b>227</b>
14.1	Social factors.....	166	18.1	Technical discussions.....	227
14.2	Technical factors.....	169	18.2	Discussions about the context, upscaling and future of SSN .....	230
14.3	Economical .....	172	19	<b>CONCLUSION.....</b>	<b>232</b>
14.4	Environmental.....	173	19.1	Technical conclusions .....	232
14.5	Political.....	174	19.2	Upscaling and future of SSN .....	234
14.6	Legal .....	177	20	<b>RECOMMENDATIONS .....</b>	<b>235</b>
14.7	Ethics .....	180			
14.8	Barriers & Opportunities.....	181			
14.9	Conclusion .....	182			

**21 REFERENCES..... 238**

**APPENDIX I ..... 243**

**TECHNICAL ..... 243**

**II.A STAKEHOLDER ANALYSIS ..... 256**

**II.B INTERVIEWS ..... 259**

**II.C RISK ASSESSMENT ..... 293**

**II.D ADDITIONAL VISUALISATION ..... 295**

**II.E CONTACTS ..... 299**







# 1 Introduction

## 1.1 Background Shock Safe Nepal

It was April 2015 when all of Nepal was hit by a huge natural disaster. A sequence of powerful earthquakes devastated both the homes and the lives of many people. A huge effort has been made to recover and rebuild the destroyed houses and families. However, not all possess the necessary means and not all areas are well accessible. Following the initiative of Cas de Stoppelaar, the Consul General of Nepal to the Netherlands, students of the TU Delft commenced the multidisciplinary student program “Shock Safe Nepal” – a program that allows engineering students of any specialty to apply and expand the research on earthquakes and earthquake safe constructions through field and volunteer work in disaster areas. This report was written by the fifth team that did research in Nepal, all builds on the knowledge of the previous teams.

## 1.2 Problem definition

A large portion of the Nepali population lives in rural areas, which have very few expedients and poor accessibility. These people have in turn little knowledge and expertise regarding the (re)construction of earthquake safe housing. Both the lack of knowledge and resources resulted in total devastation in rural areas, with little or no centralised or organised aid at their disposal. Yet it is inevitable that an earthquake or earthquakes will recur, the only uncertainty remains when.

The research of the first 3 teams has led to a design that team 4 created and a pilot house that was built in Ratankot, however, it is not possible to simply implement this design throughout all rural Nepal. Before it is possible for the design of the house to be used elsewhere and the project can be scaled up the structural calculations of the house must be conducted. Furthermore, there is no defined long term plan which is needed to decide on the next steps for SSN and the design of the pilot house. Therefore, the problem is that there is a pilot house of which the design must be validated and optimised and in its possibilities for implementation must be explored.

## 1.3 Goal

This project serves the purpose of helping to rebuild the rural areas of Nepal, in such a way that the houses will be earthquake resilient and the Nepalese people are supported in the development of their country. Shock Safe Nepal aims at providing a bridge between the knowledge on earthquake safe construction and the people of Nepal. The goal of team 5 was to validate and optimise the house built by team 4 and create a long-term plan for upscaling and implementation.

## 1.4 Research question

The problem definition and goal leads to the following research question:

*To what extent is the structural design of the house earthquake resistant and what is required to create a long-term plan to upscale in rural areas in Nepal?*

This research question will be answered with the following sub-questions:

- *What are the structural and technical properties of the pilot house, and what is the accessibility and feasibility of the required materials?*
- *To what extent is the design earthquake resilient and in which ways can it be optimised?*
- *What are the most important factors regarding the context and the requirements to upscale and implement further in rural Nepal?*
- *What are the possibilities for SSN in rebuilding Nepal?*
- *What is the most feasible role of SSN in rebuilding Nepal for the long-term?*

# 2 Methodology

## 2.1 Scope

The aim of the field work in Nepal is to validate and optimise the pilot building and to upscale this design. This research has been divided into two sections; the validation and optimisation of the pilot building in Ratankot and long-term plan for upscaling and implementation of the project.

The validation and optimisation will solely be focused on the technical aspects of the current design. This includes an extensive material study on the used materials. Namely, CSEB, bamboo and concrete. (material properties elaboration).

After the material studies, have been completed, a static analysis of the structure can be exercised regarding the roof, the bearing structure and the foundation. To answer for the earthquake resilience, quasi-static calculations will be made on the pilot building, regarding the bearing structure and the bearing capacity of the soil.

After finalising the material studies, it will be clear where optimisations are needed. These will only be addressed regarding the materials that have been used. After the static and quasi-static calculations, optimisations will be addressed regarding the design, the dimensions and its structural behaviour.

The aspects affecting the long-term plan for upscaling and implementation regarding the pilot house will be researched. The scope is narrowed down to the factors affecting the

current design, which includes stakeholders that are related to the project when upscaling the design, and the external factors such as technical, social, environmental, safety, political, legal and economical, in addition to researching the organisations that are currently rebuilding in Nepal as case studies. In this research, the costs are not considered. Now of writing the report the previous SSN team was still completing cost analysis of the current design, therefore this is not in our scope.

## 2.2 Inventory

### 2.2.1 Elaborate on previous research

The previous team has taken the designs of the preceding team, researched alternative construction materials and started the construction of the pilot building. To us it is important to investigate and continue the work of the previous teams, which will include the validation and optimisation of the pilot building. It is of great value that we can build and elaborate on the previous knowledge, research and work done by our predecessors. However, none of the teams have done calculations regarding the design, so this will be an unavoidable step to take. Team 2 designed plans to further implement and upscale the project. We will use this as our foundation for research into creating a long-term plan for upscaling.

### 2.2.2 Structure of SSN

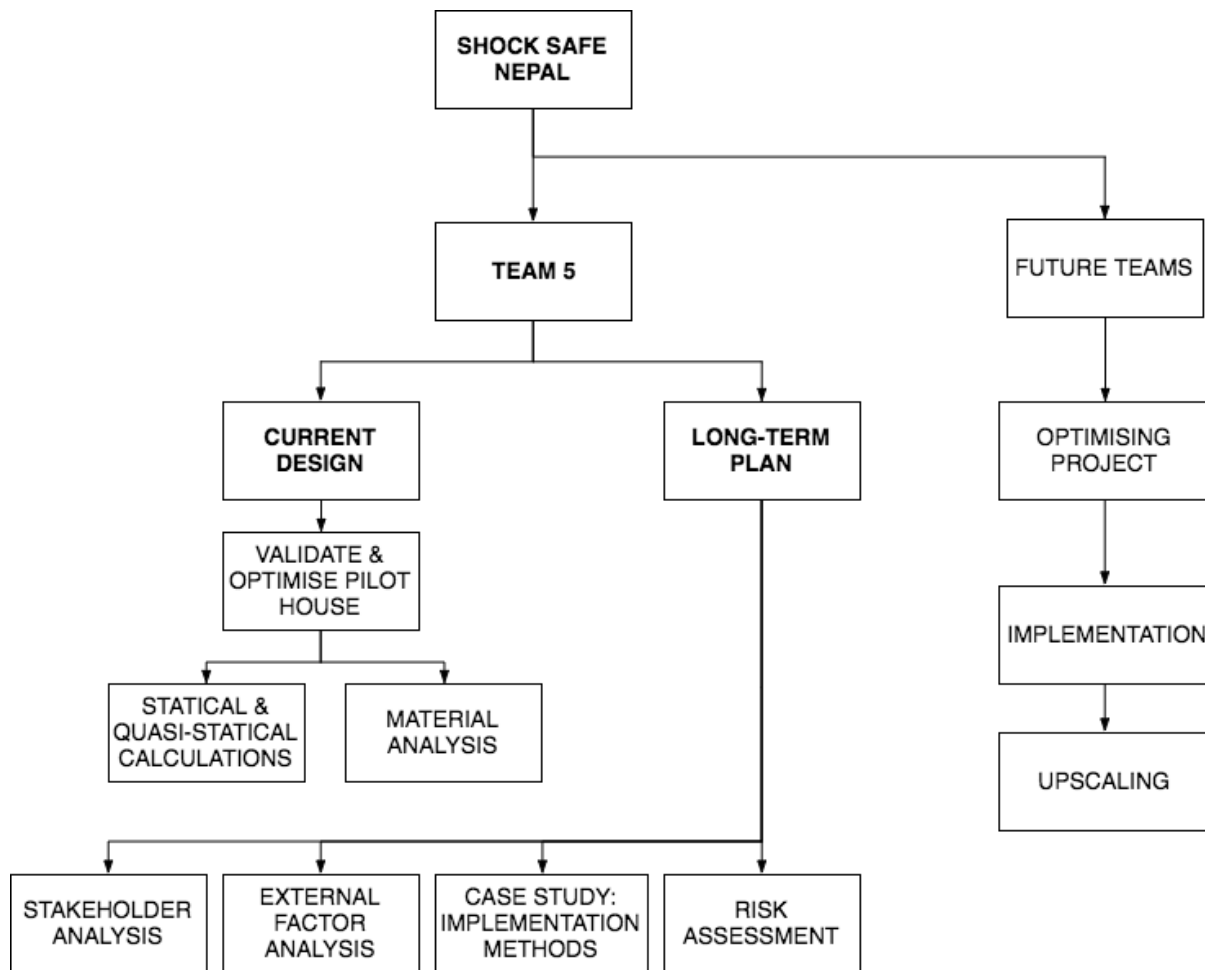

Figure 1 Breakdown structure of SSN

## 2.3 Technical validation

The house built by team 4 needs to be validated to make sure that the building is of the right quality with respect to earthquake resistance. The materials and soil properties will be investigated and determined, after which static and quasi-static calculations will be made.

### 2.3.1 Material Studies

Important factors of the validation of the technical aspects of the model house are material studies. The materials used are CSEB (compressed stabilized interlocking earth brick), concrete, steel rebar's, cement, stones and bamboo. The quality of the materials varies immensely with respect to each other and within the structure. It is of

great importance to investigate their properties, for further static and quasi-static dynamic calculations.

### 2.3.2 Literature research

To fully prepare on-site visits and on-site tests literature has been consulted. The materials used for the model house are of different quality than western materials. Literature shall mainly be consulted to prepare for tests and to find out the relevant properties of the materials to determine its quality. Furthermore, other NGOs, engineers and organizations have already done some research on the same materials, which might be a useful source to consult.



### 2.3.3 Inspections on site

A part of the material studies is the actual inspection of the materials on site. The material properties and qualities vary in every way. The primary inspections will mainly include taking pictures and documentation. However, the local people will also be asked to make some of the materials to document the construction and manufacturing process. This way the proportions and ratios of the elements of different materials can be determined in more detail.

### 2.3.4 Testing of the material

Since an inspection is just a first step in the right direction, actual testing and calculating had to be done to fully understand the properties of the materials. Unfortunately, not all materials can be tested. However, everything that can be tested will be tested, either on site or in a laboratory. The university of Tribhuvan and the Pulchowk campus have been so kind to furnish their material studies laboratory for the tests. This includes doing compression tests, slump cone tests, sieve test, etc. By doing tests on the materials, more data can be acquired, which makes it easier to determine the material quality. Besides, it will also decrease the amount of assumptions made.

### 2.3.5 Calculations

After data, has been collected and site visits have been done a fair amount of knowledge has been acquired. Now further steps towards determining the quality and properties of the materials can be undertaken. Thereafter, static and quasi-static calculations are in order.

## 2.4 Long-term plan for upscaling and implementation

After and while validating, upscaling the project and implementation are researched. This will be done through analysis and a long-term plan.

### 2.4.1 Stakeholder analysis

First, the stakeholders are analysed and their power, interest, attitude, goal and problem perceptions are determined in the stakeholder analysis. After the stakeholder analysis, a power/interest matrix is drawn up followed by a Murray Webster & Simon graphic which shows the power/interest/attitude for each actor. To show the relations between the actors and the impact they have, a network analysis is made.

### 2.4.2 External Factors Analysis

Second, a STEEPLE analysis is set out to determine the external factors of the project with the focus on upscaling and how these impact the project. STEEPLE stands for social, technical, economic, environmental, political, legal and ethical factors.

### 2.4.3 Case study: Implementation Methods

Third, implementation methods are researched. This will be done by case studies on multiple different (I)NGOs.

### 2.4.4 SWOT/TOWS

Fourth, a SWOT analysis of SSN is made to determine the opportunities and barriers. After, a TOWS analysis is made to minimise the threats and maximise the opportunities of SSN.



### 2.4.5 Risk Assessment

Fifth, a risk management plan will be set up, as risks should be considered with such a project. Risks assessment will cover the issues that can arise such as monitoring and control, supply chain, health and safety, workforce, coordination and financial management.

### 2.4.6 Long-term Plan

Finally, with an engagement plan on how to collaborate with stakeholders to achieve the objectives and an implementation pathway, a long-term plan with optimisations and alterations will be provided together with recommendations for the future.

## 2.5 Timeline and project phases

The project is divided into three different phases, shown in the timeline in *Figure 2* below. The elaboration on previous research, the validation and optimisation of the pilot house and a long-term plan for upscaling and implementation.

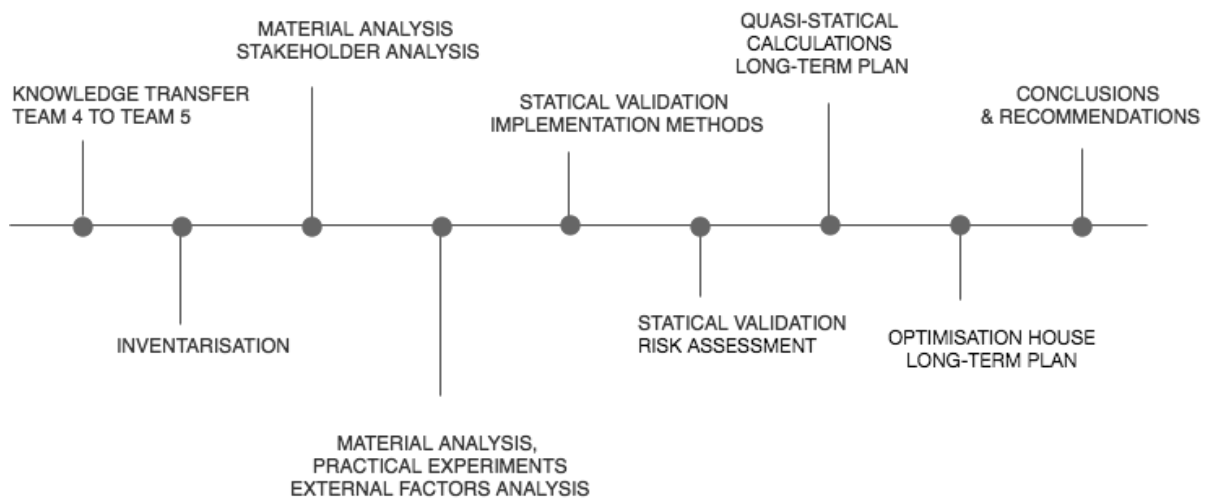

*Figure 2 Timeline and project phases of SSN5*

# PART I. MATERIALS



# 3 Materials

## 3.1 Bamboo

Bamboo is a tall grass type plant widely spread across the globe and Nepal. Worldwide there are more than 1250 species and 75 genera of bamboo (SSN4, 2016). Many different species find their roots in Nepal, some of which are fit and used for construction. The most commonly used in Nepal Bambusa Balcooa. Previous teams have done research on which type of bamboo is fit for roof construction. They have determined it fit for building shock safe, due to its local availability, lightweight and tensile performance. Subsequently Bambusa Balcooa has been used for the construction of the model house. Therefore, in the following material analysis, solely this specific type will be researched and addressed.

### 3.1.1 Mechanical properties

To determine the mechanical properties of bamboo scientific research and lab tests have been carried out on a great variety of species, among which Bambusa Balcooa. However, to evaluate the material conditions of bamboo the descent, the age, the humidity content and diameter of the material are of great importance (Bambus, 2002). These will vary from each bamboo element to another. Unfortunately, the resources to (locally) test the bamboo or in the laboratory, are not available. Therefore, when determining the material properties of the bamboo according to the sources. Their tests on bamboo properties and results, a thorough comparison between the bamboo used for testing and the bamboo used for the house must be carried out.

### Moment of inertia

Primarily the structural efficiency of bamboo, the ratio between the moment of inertia and the cross-sectional area is determined and compared to commonly used construction materials such as timber.

Bamboo has a hollow tube like structure, to determine the moment of inertia the following formula is used:

$$I = \frac{\pi \cdot (D^4 - d^4)}{64}$$

With:

$$\pi = 3.14$$

$$D = \text{external diameter}$$

$$d = \text{internal diameter}$$

$$t = \text{wall thickness}$$

Similarly, the formula for the cross-sectional area is:

$$A = \frac{\pi \cdot (D^2 - d^2)}{4}$$

Most bamboos elements have an average wall thickness of 9 mm [Janssen, 2000]. This gives an external diameter of D and an internal diameter of  $d = 0.82D$ . Consequently, this gives a value for I and A of:

$$I = 0.03 \cdot D^4$$

$$A = 0.26 \cdot D^2$$

With the formulas determined above, a ratio between the inertia and the area can be determined by taking the square of the area. Which gives:

$$A^2 = 0.07 \cdot D^4$$

The ratio between I and A will then be:

$$I = 0.40 \cdot A^2$$

In comparison to a rectangular timber beam which has a ratio between I and A of:  $I = 0.16 \cdot A^2 [mm]$ . This is much less efficient



ratio than the bamboo ratio. Which indicates that the structural efficiency of bamboo is good.

### Young's modulus

The Young's modulus is depended on and affected by many factors. The Young's modulus of the bamboo varies for the compression, tensile, bending and transversal shear strength. These modulus' must therefore all be determined separately to acquire the actual properties of the bamboo.

Sekhar and Gulati (1973) found that the Young's Modulus increases with an increase in the density (Mbuge, 2000). This is a major factor that must be considered, not only when determining the Young's modulus, but also when determining the critical stress of the bamboo, since the density affects this.

Furthermore, the Modulus of Elasticity decreases with an increase in the moisture content (Godbole & Lakkad, 1986). Hong Fan and Chengmou Fan (Fan & Fan) have also done research on the effect of the moisture content on the mechanical properties of bamboo. For the modulus of elasticity, they have shown that an increase in moisture content from 5% to 20% has a significant diminishing effect on the modulus of elasticity. From 20% the modulus of elasticity will remain a constant value. They have shown that this applies to the modulus of elasticity of compression, tensile and bending. The laboratory results and source must be carefully revised, regarding the bamboo used in Ratankot, when consulted.

### 3.1.2 Compression

The compression strength of bamboo finds its origin in the cellulose fibres along the length of the bamboo. The density of these

fibres differs from the inner to the outer shells, with a higher density of cellulose fibres on the outside than the inside.

The E-modulus of cellulose is 70000 N/mm<sup>2</sup> (Janssen, 2000). Normally the cross-section bamboo will consist of 50% cellulose fibres. Which indicates that the E-modulus of an average bamboo will be 35000 N/mm<sup>2</sup>. This value slightly differs from the inside to the outside, since the density of the fibres differ. A general rule of thumb is used to determine the E-modulus for the inside and outside of the bamboo. Most bamboos have an outside fibre percentage of 60% and an inside percentage of 10% (Janssen, 2000).

$$\text{Outside E-Modulus} = 350 \cdot \% \text{fibres outside} \\ = 350 \cdot 60 = 21000 \text{ N/mm}^2$$

$$\text{Inside E-Modulus} = 350 \cdot \% \text{fibres inside} \\ = 350 \cdot 10 = 3500 \text{ N/mm}^2$$

In addition, research, has been done on the inner and outer cellulose percentage of bambusa balcooa, by Xiaobo Li in 2011. The outer holocellulose percentage of 3-year-old bamboo was determined to be 70% and the inner on 65% (Li, 2004). However, the mechanical properties of the bamboo are mainly determined by the alpha-cellulose (Janssen, 1981). Generally, the alpha-cellulose content in bamboo is about 45 - 50%. The outer alpha cellulose percentage of 3-year-old bamboo was determined to be 49% and the inner on 43% (Li, 2004). The modulus of elasticity of alpha-cellulose however, is less than that of cellulose. The young's modulus of alpha-cellulose is like that of cotton fibres, namely approx. 50 MPa.

By using the rule of thumb, the outer and inner E-modulus of the bamboo is estimated:

Outside E-Modulus:

$$= ((50000 \cdot 0.50)) / 100 \cdot \% \text{ fibres outside} = 250 \cdot 49 = 12250 \text{ N/mm}^2$$

Inside E-Modulus:

$$= ((50000 \cdot 0.50)) / 100 \cdot \% \text{ fibres outside} = 250 \cdot 43 = 10750 \text{ N/mm}^2$$

This gives a mean E-modulus of 11500 N/mm<sup>2</sup>. Sharma et al. (2011) has also shown that the average alpha cellulose content is approximately 47.2%, which gives an E-modulus of approximately 11800 N/mm<sup>2</sup>.

Janssen also determined another rule of thumb to determine the modulus of elasticity, when laboratory tests are not available. [Janssen, 2000] This rule of thumb is based on statistics. It is calculated as follows:

$$E = 24 \cdot \text{Density of bamboo}$$

Considering these statistics are based on different species of bamboo and can therefore not be used to determine the elasticity modulus of Bambusa Balcooa.

Naik (2012) and Kabir et al (1991) have done research on the compressive strength of Bambusa Balcooa. However, they have both failed to determine or document the compressive Young's Modulus of the bamboo. Due to a lack of research done by laboratory tests on the modulus of elasticity of Bambusa Balcooa.

The results of the calculation of the elastic modulus using the first rule of thumb of Janssen with the alpha-cellulose content. The results are put in the Table 1 below:

Method	Compressive E-Modulus Bambusa Balcooa [N/mm <sup>2</sup> ]
Alpha-cellulose content - rule of thumb Janssen	10750 - 12250

Table 1: first rule of thumb of Janssen

### 3.1.3 Compressive strength

To conduct compression tests on bamboo, many factors must be considered. This translates in the fact that any source used must be critically examined and judged on its credibility.

Primarily the test setup is something to seriously revise. The effect of the plates on the friction and failure pattern is of notable significance.

The moisture content in the bamboo must be considered. Sekhar and Rawat (1956), Prawirohatmodjo (1988) and Janssen (1981) have shown that the moisture content is a significant factor when testing bamboo on compression. Studies by Hong Fan and Chengmou Fan (2000), have shown that regarding the compressive strength, the moisture content will have a negative effect when increased from 5% to 20%. After 20% moisture content the compressive strength will remain approximately constant. Regarding the model house, the moisture content is ranges from 12% to 15%, which indicates an air-dry condition.

Xiu-xin et al. (1985) and Fangchun (1981) studied the effect the age has on the bamboo for compressive strength. The results show that the strength increases with age. However, for different species of bamboo, different favourable aged bamboos are desired. Different studies show different desirable ages.



The cross-sectional area of the bamboo is mostly considered to be of cylindrical nature. However, the cross-sectional area is not a perfect cylinder and can more relate to an elliptical shape. The error which this irregularity brings forth lies between 0% to 16%. This error directly corresponds in the estimation of the stresses (Arce, 1993).

Moreover, the thickness and density of the bamboo will differ and will not be homogenous throughout the cross-sectional area. This implies that failure patterns may not correspond.

Meyer and Ekelund (1923) were the first ones to do research on the effect of friction between the steel plates and bamboo. The compression implies a longitudinal strain on the bamboo. Consequently, a lateral strain occurs as per Poisson's Effect (Janssen, 2000). Janssen (1981) and Oscar Arce (1991) have done more research in this phenomenon. When inducing a longitudinal force on the bamboo, the stiffness will mostly come from the outer part bamboo, due to the variation in axial stiffness. This means that an uneven distribution of stresses will occur. The compression in the outer rings generate relative tension in the inner rings, which induces a radial bending moment. [Oscar, 1993]. Furthermore, as per Poisson's law the compression in the outer rings will create tangential expansion, which will in turn creates contraction in the inner rings. The tangential expansion of the outer rings will induce longitudinal cracking eventually leading to failure. Oscar Arce (1993) has also shown by lab tests that the difference between expansion of the outer rings and contraction of the inner rings, will eventually lead to annular cracking and failure.

To conclude, when the steel plates perform the longitudinal force on the bamboo, it

becomes thicker in the middle. The steel plates keep the specimen together through friction at the top and bottom, inducing lateral strain at these places. The lateral reinforcement of the steel plates keep the bamboo together, resulting in more longitudinal force, this in turn give false results of the compression strength of the specimen. Therefore, a major important factor when performing compression tests on bamboo, is the usage of friction free plates.

Furthermore, the height to cross-sectional area ratio is of notable consideration. To avoid tapering as per Poisson's effect, this results in height diameter ratio of 1:1.

When performing tests on the bamboo it is important to keep in mind the distinction between bamboo compressive strength as a material and the compressive strength of the columns (Arce, 1993).

Naik (2012) has carried out laboratory research on the compressive strength of Bambusa Balcooa. Unfortunately, these tests fail to show the modulus of elasticity of the bamboo. However, Naik did provide the moisture content. The determined compression strength is approx. 69 N/mm<sup>2</sup>. Kabir et. al (1991) has also carried out laboratory tests on the compressive strength of Bambusa Balcooa. Like Naik, Kabir also failed to show the modulus of elasticity of the bamboo, but did provide the moisture content. The moisture content of the bamboo was determined at 12% and the compressive strength ranges from 51.0 to 57.3 N/mm<sup>2</sup> in air dry condition.

Janssen (2000) has created a rule of thumb to determine the compressive strength of the bamboo when laboratory tests are not

available. He has discovered a ratio between the density of the bamboo and the compressive strength is present. The rule follows:

*Ultimate compression strength*

$$\sigma_c = 0.094 \cdot \text{airdry density}$$

*Allowable compression strength*

$$\sigma_r = \frac{0.094 \cdot \text{airdry density}}{7}$$

Notable is that Arce (1993) did not find a correlation between the density and the compressive strength of the bamboo. He provides a possible explanation, which says that there is a correlation between the friction and the density of the bamboo. Which would indicate that friction free plates have not been used. Furthermore, the rules of thumb only apply to the statistics of the tests executed by Janssen. The bamboo of these tests is not of the same species as Bambusa Balcooa, which means the rule of thumb cannot be applied to the compressive strength of the used bamboo. Sckliar *et al.* (1962) and Fangchun (1981) have also determined a similar correlation and ratio's. However, these were also derived from different bamboo species, which indicates a fault rule for Bambusa Balcooa.

Unfortunately, no further research with friction free plates has been done on Bambusa Balcooa and the experiments of Kabir and Naik cannot be validated. Assumptions must be made through a comparison (Table 2). The modulus of elasticity derived from the previous chapter is 11500 N/mm<sup>2</sup>.

A comparison of the results is given in the table below.

Method	Moisture Content [%]	Age [years]	Density [kg/m <sup>3</sup> ]	Compressive Strength [N/mm <sup>2</sup> ]
Kabir	12	4	820	51.0 - 57.3
Naik	8.5	5	850	69
Mahzuz (ROT)	15.5	3	812	N.A.

Table 2: assumptions by comparison

The moisture contents of Kabir and Mahzuz will be more comparable to the bamboo in Ratankot, rather than the moisture content of Naik (Naik, 2012). The densities are almost similar and will not make the difference. The age of the bamboo in Ratankot is two years, which is closest to the age of the bamboo of Mahzuz. By using the density ratio between Kabir and Mahzuz and multiplying it with the compressive strength and indication can be made.

$$\begin{aligned} \sigma_c &= \frac{\rho_{Mahzuz}}{\rho_{Kabir}} \cdot \sigma_{c;kabir} = \frac{812}{820} \cdot 57.3 = \\ &= 54.74 \text{ N/mm}^2 \end{aligned}$$

Unfortunately, this value does not consider the previously determined modulus of elasticity. Therefore, the value for the critical compressive strength  $\sigma_c=54.74 \text{ N/mm}^2$ , will serve as an indication for the critical strength. Further calculations will be done by apprehending the modulus of elasticity.

### 3.1.4 Tensile strength

The tensile strength and maximum strain of bamboo can be observed and researched in two different ways. With tangential tensile tests or parallel tensile tests. Most research on tensile strength has been carried out performing parallel tension, due to the complications a tangential test provides.

Studies by Hong Fan and Chengmou Fan (2000), have shown that regarding the tensile strength, the moisture content will have a negative effect when increased from 5% to 20%. After 20% moisture content the compressive strength will remain approximately constant.

Xiu-xin *et al.* (1985) and Fangchun (1981) studied the effect of age on the bamboo for tensile strength. The results show that the strength increases with age. However, for different species of bamboo, different favourable aged bamboos are desired. Different studies show different desirable ages.

#### Parallel tension

Parallel tension tests have complexities as well as the tangential test methods. When testing the tensile properties of the full column, Janssen (1981) has shown that the main problems arise at the grip sections of the bamboo. The large pressure generated from the grip will produce large shear stress in the inter-fibre planes (Arce, 1993). The combination of the weak nature of the material in the transversal direction of the material and the shear stresses, will cause the material to crush in the grip sections.

Furthermore, the irregularities, such as initial cracks, of the bamboo in both the cross-sectional area as the longitudinal length of the bamboo, will bring forth multiple

complications, difficulties and inconsistencies in the test results.

When consequently testing on parallel tension Arce (1993) has found that it is preferable to use a straight specimen, with minor change in cross-sectional area. Which results into a specimen, simply being a strip of bamboo.

A few conclusions, derived from the laboratory tests of Arce (1993), regarding the parallel testing on bamboo were found:

- A significant correlation was found between the density of bamboo and the parallel tension strength.
- The nodes are the weakest link when exercising parallel tension on the bamboo. It has been found that the elastic modulus of the node section is 40% of the internode sections. Furthermore, the tensile capacity of the node sections is 30% than the tensile strength of the internode sections (Arce, 1993).
- The bamboo has only been tested using strips. A full bamboo column has yet to be tested, also considering the nodal sections, which tend to fail under less tensile stress.

The rule of thumb developed by Arce goes as follows:

$$\text{Tensile strength} \rightarrow \sigma_t = 0.4 \cdot \rho_{dry}$$

Unfortunately, this rule of thumb is derived from statistics of the bamboo he has used. This is not of the same species and therefore unreliable. To stress the reliability, another rule of thumb has been derived by Fangchun (1981).

$$\text{Tensile strength} \rightarrow \sigma_t = 0.307 \cdot \rho_{dry}$$

The differences indicate the sensitivity of the species. Also, these rules and correlations do not consider the moisture content of the bamboo, which have a huge impact on both the maximum stress as the modulus of elasticity.

Since no further research has been done on the tensile strength of full column nor on the tangential tensile strength of bamboo, the main sources which can be consulted are laboratory tests done by Mahzuz (2013) and Naik (2012). The results of Naik and Mahzuz have been summarized below (Table 3):

Source	Density $\rho$ ( $kg/m^3$ )	Age [Years]	E-modulus $E$ ( $N/mm^2$ )
Naik	850	5	-
Mahzuz	812	3	6255

Source	Moisture content (%)	Tensile strength $\sigma_t$ ( $N/mm^2$ )
Naik	8.5	164
Mahzuz	15.5	92.84

Table 3: laboratory tests done by Mahzuz (2013) and Naik (2012). (Mahzuz, 2013), (Naik, 2012)

Naik and Mahzuz have both determined the tensile strength of Bambusa Balcooa. However, using different aged bamboos and with different moisture contents. The moisture content and age of the bamboo of Mahzuz, is more likely to be like the bamboo used in Ratankot. Therefore, it is determined that the tensile strength of the bamboo will be 92.84 N/mm<sup>2</sup>.

## Young's modulus tensile stress

The longitudinal modulus of elasticity is a considerably like that of the compression strength. However, the tests are performed in a whole different manner. The compression tests are performed on cylindrical specimens with the full cylindrical cross-sectional area of bamboo. The tensile tests are performed on strip specimens.

$$E_{tensile} = E_y = 6255 \text{ N/mm}^2$$

The tangential modulus of elasticity is significantly lower than the longitudinal modulus of elasticity. When tangential forces occur in the bamboo, it's not the cellulose that is affected but the lignin. The lignin is significantly weaker to these forces than the cellulose, which results in a lower modulus of elasticity. Arce (1993) has found that the tangential modulus of elasticity is about one-eighth of the longitudinal modulus of elasticity.

$$E_x = \frac{E_y}{8} = \frac{6255}{8} = 782 \text{ N/mm}^2$$

## Tangential tension

Tangential tension tests have been done by Oscar Arce (1993). A three-point test has been done on different parts of the bamboo. The first concern and difficulty of this test was the position in the bamboo to perform the test on. The irregularities and the circular shape of the bamboo provide difficulties, deformities and eccentricities, which can influence the consistency and validation of the tests.

The main conclusions derived from these test specimens were as follows:

- There was no correlation between the density of the bamboo and the tangential tension capacity.
- The tangential modulus of elasticity is approx. one-eighth of the modulus of elasticity from the longitudinal direction. This is since the tangential modulus of elasticity is mainly determined by the lignin, instead of the cellulose.
- Arce (1993) has shown that the fibres play a dominant part in the tensile strength of the bamboo, since they can change the 'texture' of the crack path. The more fibres the crack trajectory encounters the more energy is needed for fracture. This is must however be researched in more depth.

The overall conclusion which can be derived from the research and findings of Arce, is the fact that bamboo behaves in a very proportional way and the tangential strain and stress is very specific for the species of bamboo and even each part and each column. Meaning that more studies need to be done on more species of bamboo, to find a correlation between different properties of the bamboo, to simplify the determination and characterization of the different mechanical properties of different bamboo species.

### Tangential shear and strain

Using the Poisson's value for bamboo, the critical strain parallel to the grains can be determined. By using the modulus of elasticity for compressive stress, the ultimate bending stress can be determined. For Bambusa Balcooa this will be as follows:

$$\varepsilon_{long} = \frac{\sigma_{tensile}}{E_b} = \frac{92.84}{6255} = 0.0148 \text{ mm}$$

$$\nu_{bamboo} = 0.3$$

$$\varepsilon_{lat} = \varepsilon_{long} \cdot \nu_{bamboo} = 0.0148 \cdot 0.3$$

$$= 0.0044 \text{ mm}$$

$$\tau_{lat} = \varepsilon_{lat} \cdot E_x = 0.0044 \cdot 782$$

$$= 3.47 \text{ N/mm}^2$$

The maximum tangential strain is 0.0044 mm and the maximum tangential stress is 3.47 N/mm<sup>2</sup>.

### 3.1.5 Bending strength

Bending generates compression, at the upper part of the bamboo stick, parallel to the fibres. However, following Poisson's law, this compression will also mean perpendicular tension stresses and strains. These tension stresses and strains will mainly be taken up by the lignin in between the fibres, which in turn reacts very weak to the perpendicular strains. This indicates that the critical stress will be determined by the lignin, since this will fail quicker than the parallel grains. However, the longitudinal fibres may also fail under compression.

Like the compressive strength and the tensile strength, many factors can influence the bending strength. Previously it has been stated that the moisture content, the density and the age of the bamboo must be carefully studied and considered when determining the values of the bending properties of bamboo.

### Bending modulus of elasticity

Therefore, many tests are either carried out using the modulus of elasticity derived from the tensile strength or compressive strength.

When testing on bending the fibres in the outer skin of the bamboo will be subjected to compressive stress more than the inner layer. This means that often the modulus of elasticity is used of the outer layer of the bamboo parallel to the fibres. Therefore, derived from the compressive modulus of elasticity. This modulus of elasticity is mainly higher since more cellulose is concentrated in the outer layer of the bamboo.

$$\sigma_b = \frac{92.6}{12700} \cdot 12250 = 89.32 \text{ N/mm}^2$$

The critical bending stress of the bamboo will be approximately 89.32 N/mm<sup>2</sup>.

Furthermore, research has been done by Naik and Kabir on the bending capacity of Bambusa Balcooa. There results have been summarized in below (Table 4):

Source	Density $\rho$ (kg/m <sup>3</sup> )	Age [Years]	E-modulus $E$ (N/mm <sup>2</sup> )
Naik	850	5	13603
Mahzuz	820	3	9300 - 12700

Source	Moisture content (%)	Tensile strength $\sigma_t$ (N/mm <sup>2</sup> )
Naik	8.5	151
Mahzuz	15.5	69.6 - 92.6

Table 4: Naik and Kabir bending capacity.

### Bending Young's modulus

The Young's modulus for bending is derived from the outer layer of the bamboo. Previously it was found that the value for the outer modulus of elasticity for the bamboo is 12250 N/mm<sup>2</sup>.

### Bending strength

Since the moisture content of the bamboo used in Ratankot is higher than that of Naik, this will not be used. By using Kabir's results as a ratio, the bending strength with the modulus of elasticity can be derived.

### 3.1.6 Shearing strength

There are two ways of approaching and determining the shear capacity of the bamboo. Researching either the transversal shear stresses or the longitudinal shear stresses.

#### Transversal shear/bending

By performing a four-point stress on bending, it must be carefully revised if the material fails on bending stress or shear stress. If the free span of the bamboo is too short the transversal forces will cause failure. Consequently, when the free span is long enough the strength of the bamboo will be tested solely on bending stress. This indicates that a boundary value for the free span length above which the strength is tested on bending stress and vice versa on shear stress.

Vaessen and Janssen (1997) have researched the four-point bending test and have made a model which determines the critical length, depending on the dimensions, the maximum shear stress and modulus of elasticity of the specimen (Vaessen & Janssen, 1997).

From their research, they have concluded that the mathematical model gives a good indication of the critical length. It is important to note that modulus of elasticity and the maximum shear strain and stress must be

separately determined for each different species. After which the mathematical model can be used to determine the critical length.

It is important to keep this phenomenon in mind when either determining the laboratory tests or judging and criticizing them. When too little information on the test setup is provided, it is advisable to look at other research as well.

### Transversal shear Young's modulus

The Young's modulus for transversal shear can be determined using the findings of Arce (1993). He has determined that the tangential modulus of elasticity of the bamboo is about one-eighth of the longitudinal modulus of elasticity. Which is in this case:

$$E_x = \frac{E_y}{8} = \frac{11500}{8} = 1437 \text{ N/mm}^2$$

### Transversal shear and strain

Using the Poisson's value for bamboo, the critical strain parallel to the grains can be determined. By using the modulus of elasticity for compressive stress, the ultimate bending stress can be determined. For Bambusa Balcooa this will be as follows:

$$\varepsilon_{long} = \frac{\sigma_{c,bending}}{E_b} = \frac{89.32}{12250} = 0.0073 \text{ mm}$$

$$\nu_{bamboo} = 0.3$$

$$\varepsilon_{lat} = \varepsilon_{long} \cdot \nu_{bamboo} = 0.0073 \cdot 0.3 = 0.00219 \text{ mm}$$

$$\tau_{lat} = \varepsilon_{lat} \cdot E_x = 0.00219 \cdot 1437 = 3.15 \text{ N/mm}^2$$

The maximum tangential strain is 0.00219 mm and the maximum tangential stress is 3.15 N/mm<sup>2</sup>.

### Longitudinal shear

The longitudinal shear tests are more common and performed in a similar way as the compression tests.

### Longitudinal shear Young's modulus

Since the longitudinal shear tests are mainly performed parallel to the fibres and with a similar set-up as the compression tests, the Young's modulus of the shear test is like the compressive Young's modulus. The compressive Young's modulus has previously been determined to be 10750 - 12250 N/mm<sup>2</sup>, with an average of 11500 N/mm<sup>2</sup>.

### Longitudinal shear strength

Naik (2012) has carried out laboratory tests on the longitudinal shear strength of Bambusa Balcooa. His results are shown below (Table 5):

Source	Density $\rho$ (kg/m <sup>3</sup> )	Age [Years]
Naik	850	5
Source	Moisture content (%)	Shear strength $\sigma_s$ (N/mm <sup>2</sup> )
Naik	8.5	11.9

Table 5: laboratory tests on the longitudinal shear strength by Naik

Without further knowledge of the longitudinal shear strength of Bambusa Balcooa, the critical value is determined for 11.9 N/mm<sup>2</sup>. It is important to note that this value will just be used as an indication, since the other properties of the bamboo of Naik are not all



like the properties of the bamboo used in Ratankot. Therefore, when further calculations are done, the longitudinal modulus of elasticity, derived from the compression modulus of elasticity, will be apprehended.

### 3.1.7 Durability

Bamboo is considered as a suitable building material thanks to its elasticity, flexibility and structural capacity. These qualities are mainly linked to the inner chemical and anatomic composition of the material itself. As the main known wood species, bamboo is mainly composed by cellulose, hemicellulose and lignin, up to a total influence of 90 % approximately on the total mass [Higachi, 1957]. However, other than wood, the structural response of bamboo does not change considering different direction of load applications (radial, longitudinal and transversal), thanks to its lack of rays and knots in the inner structure. This even results in a more spread stresses distribution along the hollow tubes length.

For a deeper understanding of the whole chemical properties of bamboo, both the longitudinal and transversal composition of the material will be explained.

#### Hollow tubes – longitudinal

The flexibility and elasticity of the material depends on the inner longitudinal structure of the bamboo elements. Microscopically, the structure is present as an organized architecture of hexagonal cells. Hemicellulose fibres (hemicellulose and  $\alpha$ -cellulose) are aligned along the length of the bamboo hollow tubes, imbedded in a lignin matrix, providing a high flexural tensile strength and rigidity.  $\alpha$ -cellulose is the main component, for a total amount of around 40-55% of the total mass depending on the age of the considered bamboo. It is a homopolysaccharide made of glucose

molecules ( $C_6H_{12}O_6$ ) kept together by covalent glycosidic bonds, working as sugar rings and making the inner structure continuous along the bamboo length. This is ensured by the tendency of  $\alpha$ -cellulose molecules to stay linear and make intermolecular hydrogen bonds, while hemicellulose supports the walls of the molecules made of  $\alpha$ -cellulose [Xiaobo Li, 2004].

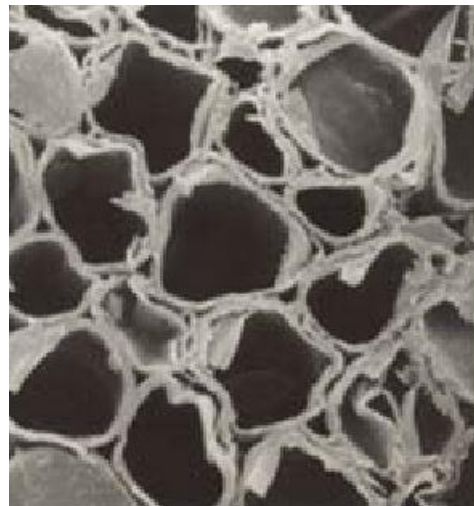

Figure 3: *B. balcooa* walled hexagonal cells [Sharma et al. 2011]

It is the  $\alpha$ -cellulose content that gives structural resistance to the material, that will be considered for the calculation of the Young Modulus further. It will be considered that different amount of  $\alpha$ -cellulose can be found in the internal and the outer side of the bamboo hollow tubes as visible from Figure 3 (Li, 2004).

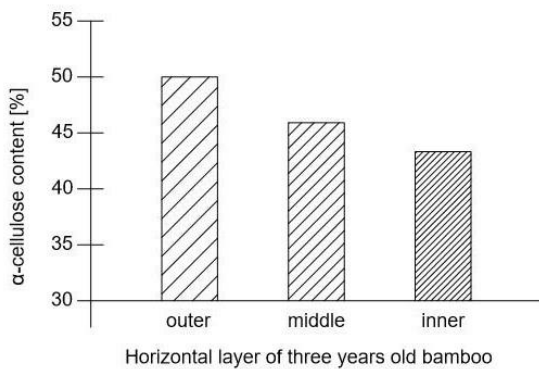
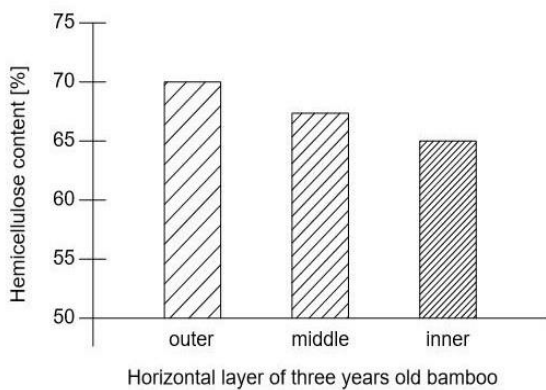

Figure 4: hemicellulose and alfa-cellulose content in horizontal layers of bamboo [Xiaobo Li, 2004]

Figure 2: hemicellulose and alfa-cellulose content in horizontal layers of bamboo [Xiaobo Li, 2004]

Bambusa balcooa, compared to other bamboo species, has longer fibres ranging around 2-2,2 mm, ensuring more performative tearing resistance (Sharma et al. 2011).

The matrix of the material is then made of lignin, which is a polymer of phenylopropane units interconnected together. It is present with an average amount of around 20-25% of the total mass. There is no significant difference about the amount of lignin present in the different horizontal layers of bamboo; however, the total amount of lignin is strongly dependent on the age of the bamboo, increasing with the time. This matrix provides the structural rigidity to the

bamboo keeping interconnected together the homocellulose fibres [Scurlock, 2000].

The remain portion of material then includes starch (2-6%), deoxidized saccharide (2%), fat (2-4%) and protein (0,8-6%) depending on the age of growth (Li, 2004). These components are considered as “ash content” or “ash portion”, including the whole inorganic components of the inner structure of the material. Chemically, they are mainly made of calcium, silica, potassium manganese and magnesium, with the latter two in low proportion. As for the lignin, the amount of ash does not differ between the horizontal layers of the bamboo. However, it decreases with time, ensuring less weakness points for older hollow bamboo tubes.

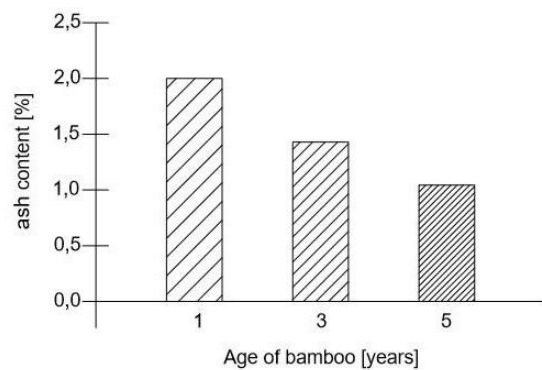
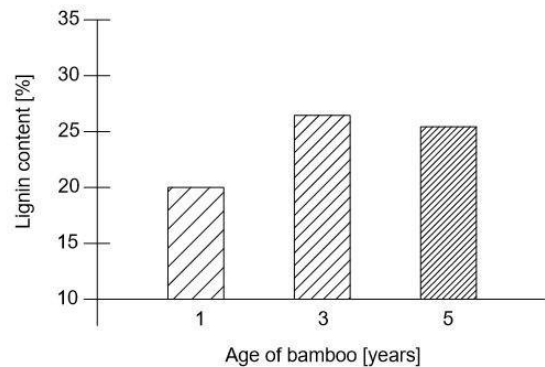

Figure 5: Lignin and ash content depending on bamboo ages [Xiaobo Li, 2004]

The structural capacity of the cross section, as well as for the longitudinal direction, strongly depends on the chemical composition of the material. It will be explained how the Young modulus of the material changes referred to the quantity of  $\alpha$ -cellulose present in its different horizontal layers. Vascular bonds are here present, with different density through the cross section; higher the distance from the centrum, higher the bonds' density [Shito et al., 2002]:

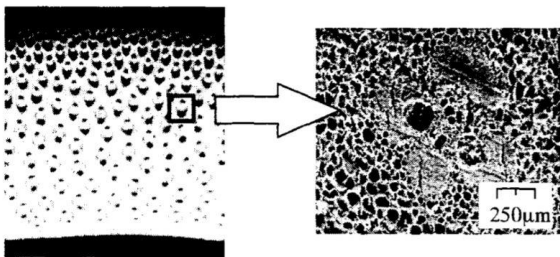

Figure 6: Cross section of bamboo and bonds distribution [Shito et al. 2002]

### Durability issues

The risk of degradation mechanisms for bamboo elements is already widely well-known. Bamboo can be attacked by factors that compromise its durability during all the stages of its harvesting, storage and on site location, by bacteria, fungi and other organisms [Liese and Kumar, 2003]. Due to the high dependency on the nature and the specie of the material itself, the weather conditions and the processes that bamboo elements follow during their processing, scarce researches are nowadays available to mark common results or model that could be used to determine durability properties in relation to the material itself and environmental conditions [Kumar et al, 1994]. However, a rough guideline on the service life of untreated bamboo has been made and it is shown below [Janssen, 2000]:

- 1-3 years where open and in contact with soil;

- 4-6 years under cover conditions and free from contact with soil;
- 10-15 years under monitored and safe storage/use conditions;

Many factors influence the durability behaviour of bamboo elements in certain environmental conditions. Firstly, the hollow tube shape of bamboo sticks allows a double-direction entrance for harmful organisms into the material. Wooden materials have generally solid and compact inner structure, that permits the entrance of organisms only from the outer direction; even if the wooden surface was attacked, it could still offer a good performance even without the outer layer. This is not valid for bamboo hollow tubes, made even worse by the its cross-section dimension with limited thickness. In this case, no natural nor chemical treatment are available to modify the structure and the shape of the material to improve the durability performance of bamboo.

Another factor that plays an important role regarding the durability is the environmental condition where the bamboo grows and is then used on site. The high moisture percentage, or the inner water content, permits the transportation of damaging organisms from outside to the inner structure of the material. This mostly happens during harvesting phases. Once these organisms are inside, they cannot be expelled naturally. Furthermore, inner composition of bamboo layers includes high percentage of glucose units joined by glycosidic bonds ( $C_6H_{12}O_6$ ), that can feed fungi and bacteria once they are present inside. The high amount of inner water and the starch content in the structure of the material create a perfect environment for organisms to grow and destroy bamboo layers.

The risk that organisms can damage the material is actual even after the material have been cut. The outer bark of bamboo makes the material compact and waterproof, as well as the continuous inner layer. The high silica content of these layers make a resistive coat for insects and bacteria entrance. However, conductive vessels are still internally present and they can work as bridges to let organisms getting inside the material structure. The inner presence and distribution of vessels, as well as for the bonds that influence the structural properties of the material, highly depend on so many factors related to the specie of the material and the environmental conditions where it grows that this mechanism should be analysed situation by situation to have reliable values. However, it has been analysed that these vessels close forever within 24 hours after harvesting [Janssen, 2000]. The fact that bamboo is then not sawn does not allow to create vessels connection or cells opening, as it happens for treated and cut wood, increasing the risk of penetration of damaging organisms for the latter.

Research has been conducted by Schmidt and Wei, 2011, analysing the reactions of several species of bamboo when in contact with soil and when kept dry but always in contact with white and brown-rot fungi under laboratory conditions. The nature of the fungi has had high influence on the degradation mechanisms of bamboo: white-rot fungi made samples deeply degrading when in contact with soil, while brown-rot fungi damaged samples in a dry environment. However, these degradation mechanisms are still influence of the inner composition of the material, which is function of the age and environmental growth condition of the elements. In fact, the presence of conductive cells, or vessels, varies through the culm of bamboo [Liese, 1998]. At the bottom of the culm, the presence of parenchyma cells, or

cellulose, is much higher than at the bottom where more vessels can take space and allow deeper organisms entrance. To ensure certain durability performance of bamboo, soil composition and environmental presence of certain bacteria analysis should be conducted to make the growth and harvesting processes as much performant as possible.

Finally, the conditions at which the bamboo is cut have high influences on the performance of the material itself [Magel et al, 2006]. The content of protein and starch vary during the years and through the culm development. Since bamboo performances are function of the inner structure of the material, monitoring and coordination operations should be done to harvest the bamboo hollow tubes at a specific point of their growth, with a related certain inner composition.

To improve the durability properties of the material, many treatments can be done naturally or using chemical additives, as well as specific on site guidelines should be considered to avoid the material location close to more damaging conditions. The goal of these phases is to change the material composition, changing then its reaction to certain components or environmental conditions. As it has been explained above, the three main factors that influence the durability of bamboo elements are its inner chemical composition, with high percentage of glycolysis components, its water content and the presence of vessels that can let damaging organisms getting inside. To influence these aspects there is the availability of a few treatments that can be conducted to improve the bamboo durability.

Naturally, bamboo elements can be treated with transpiration processes and smoking.



This causes the falling of the starch content, avoiding the inner presence of chemical components that could feed fungi and insects. The same principle is followed by soaking and seasoning processes, where bamboo sticks are left immersed into water bath for several weeks, making the sugar components leaching out from inside. When dried, bamboo is then treated superficially with natural material solution, as it can happen with lime-washing, which is thought to protect the surface from fungal attacks. Burning the surface of the material with direct flames is another solution to make the material harder and more resistant against entrance of damaging organisms: here the chemical structure would be modified. When glucose molecules are heated up, glycosidic bonds are melted up and they create a denser interconnection with between inner chemical components. Once they are cooled down, they become strong and compact, creating a resistant and continuous surface no attackable by fungi and bacteria anymore. The continuity of the surface makes the bamboo even completely waterproof. However, this treatment would compromise the structural behaviour of the material; on the one hand, higher strength would be ensured; on the other hand, when glucose molecules are heated up they lose their elasticity and become brittle.

The material can also be treated chemically; the goal of this process is make the vessels to work as weak points for damaging organisms entrance. Preservative solutions, as boric acid, borax and boron-based fertilizer, are sprayed into the bamboo hollow tubes and pressurized until the moment when preservative solution will come out from the opposite end of the culm compared to the one chosen as starting point for the treatment. This process is already widely used thanks to its cheap costs, the gained performance and its speed (1-2 hours depending on the length of the bamboo

element). The same penetration principle can also be done thanks to immersion in solution baths; this will ensure that the material will be saturated as it happens using a pressurizer, however taking more time (at least three weeks) [Janssen, 2000].



*Figure 7: water leaching process, diminishing starch content of the material*

### Size

Bamboo length and thickness strongly depend on the considered specie and the age of the material. Under extreme conditions, some species can achieve 40 m of height and 30 cm of diameter. Several researches in the past 20 years have been carried on analysing the influence of those two factors on the final dimensions. However, because of the nature of the material itself, geometrical parameters vary situation by situation, element by element. Different ages, environmental conditions and sun exposure make change on the final dimension on the hollow tubes when cut down. This phenomenon can be easily seen even in the model house built in Ratankot: the hollow tubes of the roof have been measured and 5 of them are then reported below. Thickness and the diameter of the structural elements changed even considering elements grown under the same environmental conditions.

To make further analysis, as hand-made structural calculations, it is reasonable to

assume an average value for the geometric dimensions of the cross section of the bamboo elements, that will result in a certain assumed moment of resistance and moment of inertia. Making an average about the dimension of the considered bamboo hollow tubes and taking them approximated, the final size of all the sticks will be:

$$d_{\text{average}} = 65 \text{ mm};$$

$$t_{\text{average}} = 15 \text{ mm};$$

## 3.2 CSEB bricks

Most the walls of the model are built with Compressed Stabilized Earth Bricks, commonly known as CSEB bricks. An amount of slightly moistened soil is compressed in a manual or motorized machine. (Auroville, Auroville Earth Institute , 2012)The bricks can be pressed in any desired shape or size depending on the machine. The machine which is used in Ratankot is a double press machine and was provided by Build Up Nepal. This machine presses interlocking CSEB bricks. The material properties and the properties of the walls have been based solely on these specific bricks.

### 3.2.1 Properties

#### Composition

CSEB bricks consist of soil, sand and cement. The soil consists of sand, clay, gravel and silt. The exact composition ratio is as follows. The mixture is made from 50% sand, 20% clay, 15% silt and 15% of gravel. At the end 10 % cement is added to the mixture.



Figure 8: Mixture for CSEB bricks (Build Up Nepal, 2016)

Because of the addition of moisture, the sand bonds with the cement. Compression will increase its density and the sand - cement bond will increase the strength of the brick resulting in a brick with comparable properties as concrete or fired bricks. (BuildUpNepal, 2016)

Usually only 5% of cement is added to the bricks composition. However, Build Up Nepal uses 10% to increase the strength of the brick. This increased the compressive

strength of the brick with 4 - 5 MPA (BuildUpNepal, 2016).

#### Mechanical properties

Build Up Nepal initiated the provision of CSEB bricks in Nepal. Material property tests have also been carried out by them in cooperation with the university of Tribhuvan in Kathmandu. The bricks have been tested on several properties at Central Material Testing Laboratory on the campus of Pulchowk.

#### Size

The brick in question is an interlocking brick with the dimension 300x150x100 mm<sup>3</sup>.

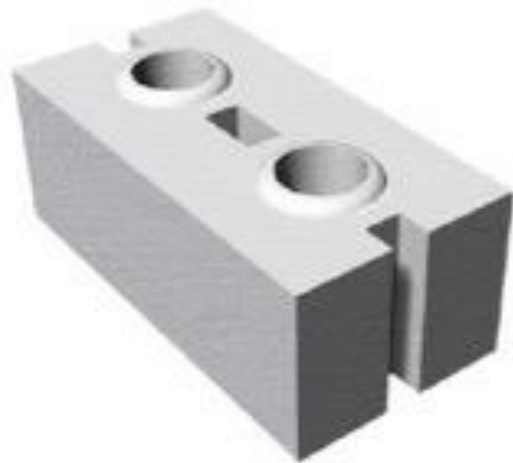

Figure 9: CSEB

#### Ultrasonic Pulse Velocity Test

Primarily an Ultrasonic pulse velocity test has been carried out to determine the range of the Young's Modulus. The following formula has been used to determine the relationship between the Young's modulus, the density, the Poisson's ratio and the velocity of the P-wave: (BuildUpNepal, 2016).



$$E = \frac{(1 + \nu)(1 - 2\nu)}{(1 - \nu)} \rho V_p^2$$

The Poisson's ratio of the CSEB bricks ranges from 0.15 to 0.35, its value has been assumed constant with a value of 0.25. A sensitivity analysis has been done on the influence of the Poisson's ratio, since it has primarily been assumed to be constant.

After performing the Ultrasonic pulse velocity test and the sensitivity analysis on twenty different bricks the average values of the constants have been determined.

Constant	Avg. Value
Poisson's Ratio [-]	0.25
Density [kg/m <sup>3</sup> ]	1546
P-Wave [m/s]	1426
E-Modulus [GPa]	2.7

Table 6: Constants of a CSEB

### Compression strength test

The compression tests have been carried out on 9 blocks, of which 3 hollow and 6 filled. Since some of the bricks in the model house have also been filled with concrete these results are applicable. The results from the laboratory tests show the following results.

Hole Filled Interlocking brick [300x150x100 mm<sup>3</sup>]:

Block [#]	Density [kg/m <sup>3</sup> ]	Compression Strength $\sigma_c$ [MPa]
1	2251	7.45
2	2229	8.06
3	2044	6.3
4	2216	8.14
5	2093	7.34
6	2311	7.5

Table 7: Hole filled interlocking brick density and compression strength

Hole Not Filled Interlocking brick [300x150x100 mm<sup>3</sup>]:

Block [#]	Density [kg/m <sup>3</sup> ]	Compression Strength $\sigma_c$ [MPa]
1	1727	5.53
2	1882	5.2
3	1882	5.35

Table 8: Hole not filled interlocking brick density and compression strength

The results give an average density of 1830 kg/m<sup>3</sup> and a compressive strength of 5.36 MPa for the interlocking bricks with the unfilled holes and an average density of 2190 kg/m<sup>3</sup> and a compressive strength of 7.47 MPa for the bricks with the filled holes.

### 3.2.2 Durability

A lot of studies have been done with respect to the durability of the hollow interlocking stabilised earth brick. A paper about "A Brief Review of Compressed Stabilized Earth Brick" stated the following:

*The basic principal of the stabilization is to prevent water attacks and it could be achieved if a durable material can be obtained with limited loss in mechanical strength in a wet state. From several experiments, durability associated with the stabilizer content, clay content and compacting stress. Basically, durable stabilized clay material building can be achieved if they are not saturated. The problems arise when the materials are subjected to the long-term saturation and exposed to various climatic conditions. Also, it is observed that the presence of unstable material was likely to be particularly detrimental to the durability (Zaidi, 2010).*

The durability of CSEB varies largely depending on the ratio of the ingredients but also with the influence of loads and the weather. A study done by "Iyambo Ipinge" gives inside on the durability of CSEB

interlocking bricks. Ipinge, has found out that in certain cases as much as half of the dry strength of blocks is lost when blocks become saturated (Ipinge, 2012). In the study, a large scale of compositions is considered. The conclusions of the study with respect to durability are the following:

- Reviewed literature suggests that the strength and durability of a CSEB is directly related to the proportion of clay and cement in the block.
- Increase of clay with a constant percentage of cement weakens the block.
- Increase of moisture content in blocks at constant percentage of clay and cement act to weakens the block.
- Water generally reduces the strength of CSEB and that reduce is larger with growing percentages of clay.
- By increase of the cement content the block will be stronger, uptake less water and will reduce less in losses by abrasion/erosion.
- The use of chemicals can be helpful for the durability of the blocks.
- Cost is a major factor when taking the ability to achieve a certain standard of durability into consideration.

According to this, the blocks will have more compression strength if there is more sand or less clay in it. In practice, it is impossible to build bricks with less than 10 percent clay [Interview Bjorn 27-2]. The bricks will simply fall apart after pressing. The only way to build blocks with less than 10 percent of clay in it, is to press the brick and then leave it in the machine for a couple of days. This will give the cement time to bind and make the block strong enough for transportation out of the machine. This is just not feasible because the machine should press around 300 blocks per day. Build Up Nepal is

working with soil that consist between 10 and 30 percent of clay [Interview Bjorn 27-2].

As stated in the conclusions of Ipinge, the water absorption is a function of cement and clay content in the block and therefore related to the strength. If the absorption is too high, the stabilized clay fractions could swell up and this means that strength could be lost in time. The blocks need to be protected against the rain and water for this matter.

The shrinkage of the blocks is the biggest in the first four days of curing process (Ipinge, 2012). The higher the clay content in the block, the more shrinkage the block will experience. This is because the water-loss contributes to the shrink of the clay fractions in the block.

## 3.3 Concrete

### 3.3.1 Concrete properties

To validate the structural performance of the load bearing structure of the house in Ratankot, studying properties of the materials that have been used was necessary. After on site investigation and analysis, it was noticed the remarkable bad quality of the material. The construction processes have been investigated, and it has been realized that workers made the concrete on site without following a precise ratio of proportions of the mix components, even keeping low level of attention about mixing and curing operations that should have been followed to guarantee a certain level of performance.

In this situation, it was not possible to assume a certain average value for the material properties and testing the material as it has been made was necessary. Firstly, visual inspections have been made and then deeper analysed once back in Kathmandu, remarking the bad quality of the material studying the depth, size and distribution of the voids on the surface. Then, the on-site construction operations have been studied, to remake the material once into the laboratory as closer to how it has been made as possible. Once in the laboratory, the size of the used aggregates has been studied, and slump test and compression tests have been conducted. These tests results could give us more reliable values about the actual performance of the material as it has been made by local workers.

### Construction operations

The on-site construction operations have been followed and analysed. The result is that local workers did not carefully follow specific proportions of components to make



Figure 10: Mixture components

the mix. The ration between aggregates, sand and cement has been kept roughly 3:2:1 respectively, measured in volume using local low quality devices (Figure 10).

After laboratory inspections, it has been discovered that the ratio between these components has been roughly respected; however, the volumes and the proportions also include the voids that are present between components, then, as will be visible for the sieve analysis, the results used proportions are not precise. Local stones have been used as aggregates, without previous selection about their size and origin, as well as for the used sand (Figure 11). No chemical studies have been conducted to analyse the chemical composition of them. Pozzolanic cement has been used into the mix. Low level of attention has been kept for the used quantity of water into the mix; workers tent to increase or decrease the amount of water “by feelings”, using approximately 200-250 L of water per 150 kg of cement.



Figure 11: bucket used to measure volume proportions of components

After on-site investigations, the surface quality of the concrete elements has been valued looking at the voids surface that was superficially present, their depth and their distribution. Certain portions of structural elements are highly damaged. No relevant differences are present for horizontal and vertical elements, the quality of the concrete stays poor for both. Spalling areas and aggregates are easily noticeable visually, giving reliable confirmation about the not adequate previous concrete mixing operations.

Three different portions of the concrete structure have been visually analysed for both the vertical and horizontal structural elements (15 x 15 cm for the first ones, 10 x 9 cm for the latter). The voids distribution and depth have been determined. The goal of this step was to make a comparison between the composition of the different structural portions, analysing if it was possible to make common assumption about how the structural performance is influenced by the surface quality. The results are shown (Table 9 & Figure 12).

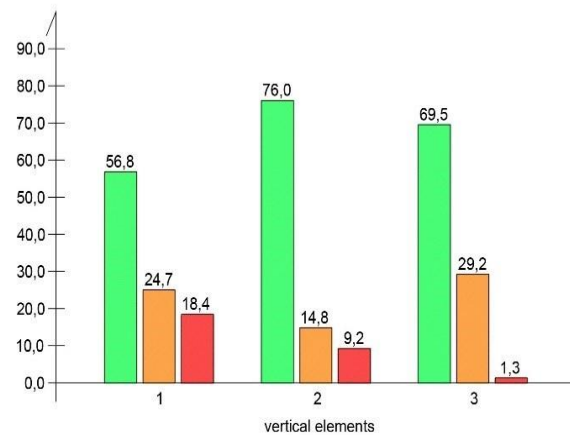

Table 9: voids depth and surface quantity for different structural portions

AIR VOIDS DIMENSIONS AND PERCENTAGE						
vertical elements						
n.	total surface	voids	colour	voids depth	voids surface [mm2]	%
1	22500 mm2	distributed	green	< 2 mm	12778	56,8
		surface damages	orange	2 - 5 mm	5563	24,7
		deep and localised	red	> 5 mm	4141	18,4
2	22500 mm2	distributed	green	< 2 mm	17092	76,0
		surface damages	orange	2 - 5 mm	3336	14,8
		deep and localised	red	> 5 mm	2064	9,2
3	22500 mm2	distributed	green	< 2 mm	15641	69,5
		surface damages	orange	2 - 5 mm	6574	29,2
		deep and localised	red	> 5 mm	284	1,3
horizontal elements						
n.	total surface	voids	colour	voids depth	voids surface [mm2]	%
1	9000 mm2	distributed	green	< 2 mm	4571	50,8
		surface damages	orange	2 - 5 mm	1923	21,4
		deep and localised	red	> 5 mm	2506	27,8
2	9000 mm2	distributed	green	< 2 mm	5151	57,2
		surface damages	orange	2 - 5 mm	3289	36,6
		deep and localised	red	> 5 mm	580	6,2
3	9000 mm2	distributed	green	< 2 mm	7120	79,1
		surface damages	orange	2 - 5 mm	338	3,8
		deep and localised	red	> 5 mm	1541	17,1

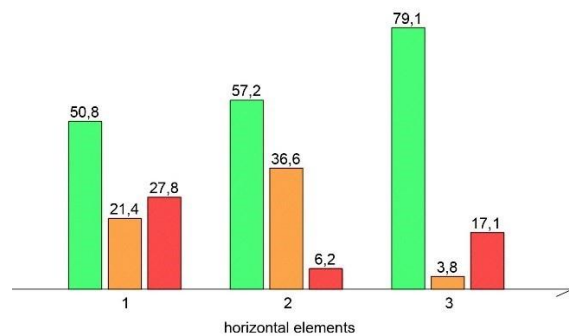

Figure 12: voids surface percentage for different material portions

The average presence of distributed-non-deep voids does not change considerably between vertical and horizontal elements

(67,5% for the first against 62,4% for the latter), as well as the voids that reach 5 mm in depth approximately (22,9% against 20,6%). However, a more remarkable difference is noticeable about the localized and deep voids (red, 9,6% against 17,0%); this can be explained by nature of the structural element itself, where vertical elements can compact themselves more thanks to gravity forces, needing less compaction processes. However, to facilitate structural calculations, it can be assumed that the quality of the material does not change between horizontal and structural elements.



## Sieve analysis

The aggregates size has been analysed thanks to the Sieve analysis, done into the Laboratory of Materials at the Faculty of Civil Engineering, University of Kathmandu. A certain amount of material has been taken from the site and brought to the laboratory before it was mixed with water. A total volume of  $3,375 \cdot 10^6 \text{ mm}^3$  ( $150 \times 150 \times 150 \text{ mm}^3$ ) has been analysed, even including sand and cement portions. Because it has been seen that the ratio between components has been approximately kept as

3:2:1 for aggregates, sand and cement respectively, it would be reasonable to assume that the total volume of aggregates that have been analysed is around  $1,6875 \cdot 10^6 \text{ mm}^3$ , equal to the half of the considered total volume. However, due to the random used of aggregates, a huge part of them measured a diameter less big than 2 mm. We considered those as sand particles, then the total volume of the aggregates resulted  $1,08 \cdot 10^6 \text{ mm}^3$  measured as the sum of all the portions of aggregates got from the Sieve analysis, which results are reported below (Table 10):









sieve [mm]	sieve picture	aggregate	volume [mL]	volume [mm <sup>3</sup> ]	amount [%]	kept [%]
40,0	-	-	0	0	0,00	0,00
31,5	-	-	0	0	0,00	0,00
25,0			55	$55 \cdot 10^3$	5,10	5,10
19,0			230	$230 \cdot 10^3$	21,30	26,60
12,7			225	$225 \cdot 10^3$	20,83	47,43
9,5			105	$105 \cdot 10^3$	9,72	57,15
4,75			190	$190 \cdot 10^3$	17,59	74,74
2,0			275	$275 \cdot 10^3$	25,26	100,0
TOT			1008	$1,08 \cdot 10^6$	100	100

Table 10: Sieve analyses



After the sieve analysis, the granulometric curve of the mix has been made. Despite the randomly selection of the size of aggregates that have been used, as mentioned below, the aggregates size distribution does not differ remarkably from the Fuller's curve (Figure 13). It must be mentioned that no results are available for aggregates with size equal or less than 2 mm in diameter, caused by the no availability of sieves with smaller diameter at the laboratory. However, it must be said that the following results give only an

indication about the size of aggregates that are commonly used to make the mix design of the concrete. On-site inspections proved in fact that big stones are broken "by feeling". The angular shape that is kept for the aggregates, after breaking operations, also influence the higher amount of water needed by the workers to make the mix more workable.

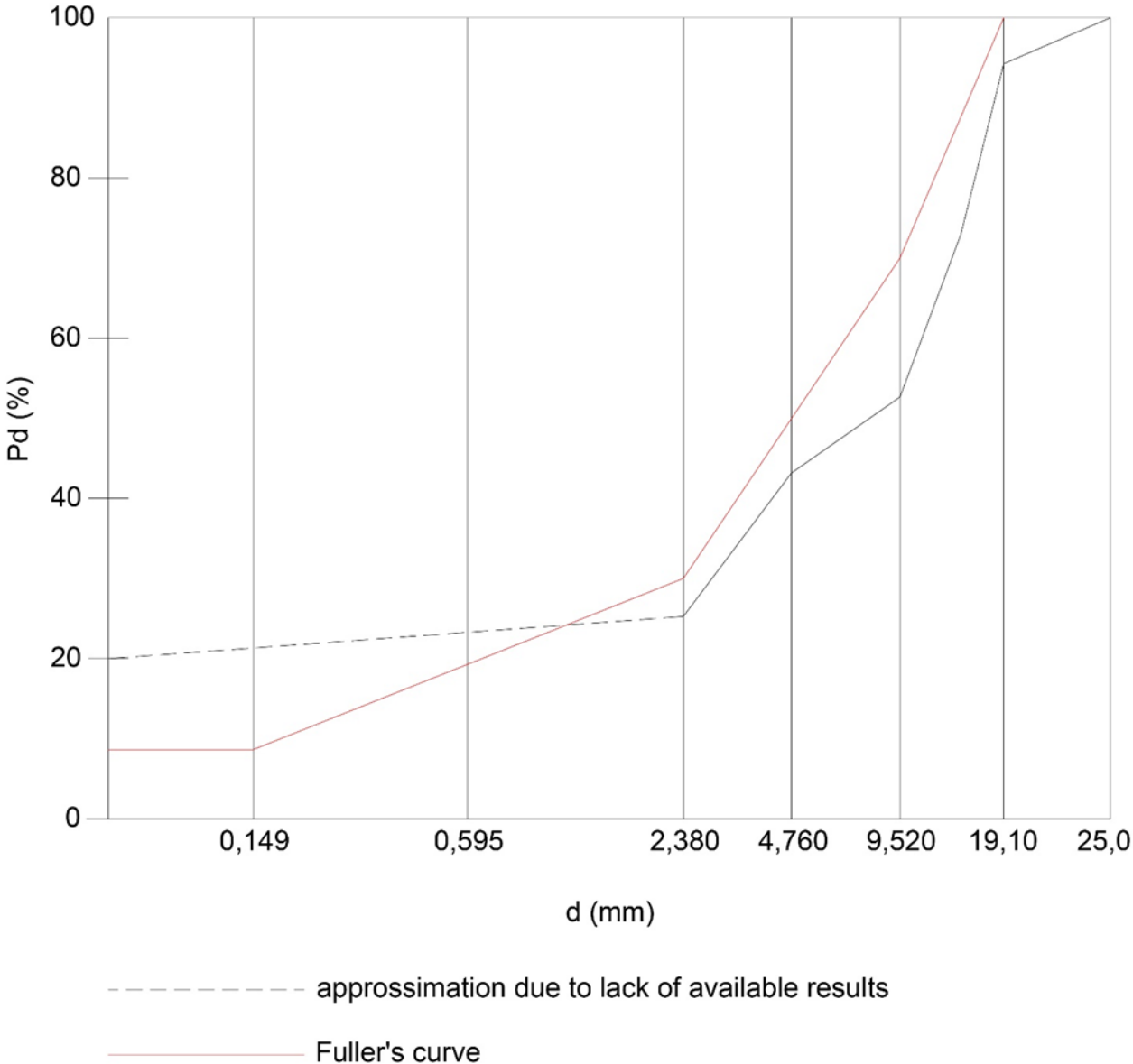

Figure 13: granulometric curve of aggregates

## Slump test

Once the concrete has been made and before putting that into the moulds, a slump test has been conducted to analyse the class of consistency of the material. The reference values have been taken from the Eurocode 2 about construction materials. The result is shown below (Figure 14):

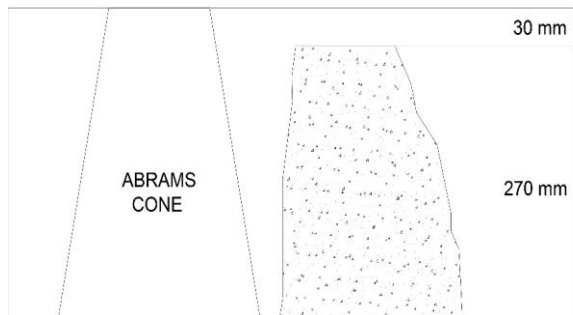

Figure 14: slump test result for casted concrete

As visible above, the class of consistency of the concrete is S1, relative to a slump value of 30 mm approximately (Figure 14 & Figure 15). This was already roughly deductible from the visual investigations that have been conducted: the high amount of surface voids could have been easily explained by low level of plasticity of the material, resulting in a scarce performance to fill the gaps created by the wooden plates to give a shape to the structural elements. This, accompanied by the possibility to face the presence of big



Figure 15: laboratory slump test

aggregates, results in the loss of material

surface and the creation of weak points into the material.

## Schmidt hammer test

To have an overview about the compression strength of the on-site concrete, a Schmidt hammer has been taken and used, provided by the Institute of Engineering at the University of Kathmandu. Before going on the site, the reliability of the results given by the Schmidt hammer has been tested. This has been done making three concrete cubic samples directly on the laboratory. These samples have been made following the prescription and receipt that have been used to make the concrete by workers at the village of Pipaltar, where Habitat for Humanity actively works in reconstruction programs. The making procedure has been directly into the laboratory with the same materials that are currently used in Pipaltar to make the concrete, picking them up during the second visit of the group at the village.

Once there, a lack of precision and respect of proportions between the concrete components has been noticed. The proportions between aggregates, sand and cement has been taken as 3:2:1 respectively measured (roughly) by volume. A total amount of 200 L approximately has been used per every three boxes of cement, each one of 50 kg.

Two more samples have been taken from the laboratory, which were already made by laboratory workers to have more data to compare the reliability of the device. Before conducting the compression strength tests, the Schmidt hammer has been used on the samples that would be then tested. Three sides of each concrete block have been tested, the top one and a lateral one, with 9 points testing per each one (Figure 16). However, because of the lack of tensile strength of the concrete blocks, made even worse using too big aggregates, during this phase some blocks have been damaged at

some corners or at weak points; in this situation, less data has been recorded. Then the relative R (Hammer number) coming out from the Schmidt hammer have been used to make an average and to get finally to an average result about the concrete compression strength. These results have been then compared to those coming from the uniaxial compression tests conducted on 28<sup>th</sup> February 2017 at the Central Material Testing Laboratory at the Institute of Engineering of the University of Kathmandu, under the supervision of Mr. Rajendra R.

Pant, Deputy Chief of the Laboratory of Testing Materials. The reliability of the Schmidt hammer results could give us the possibility to go on the site at Ratankot and conducting analysis about the compression strength and the inner quality of the material as it has been made. The blocks (Figure 16) have been made following the receipt used at the village of Pipaltar, as already mentioned. After seven days of treatment at the laboratory, the tests have been conducted.

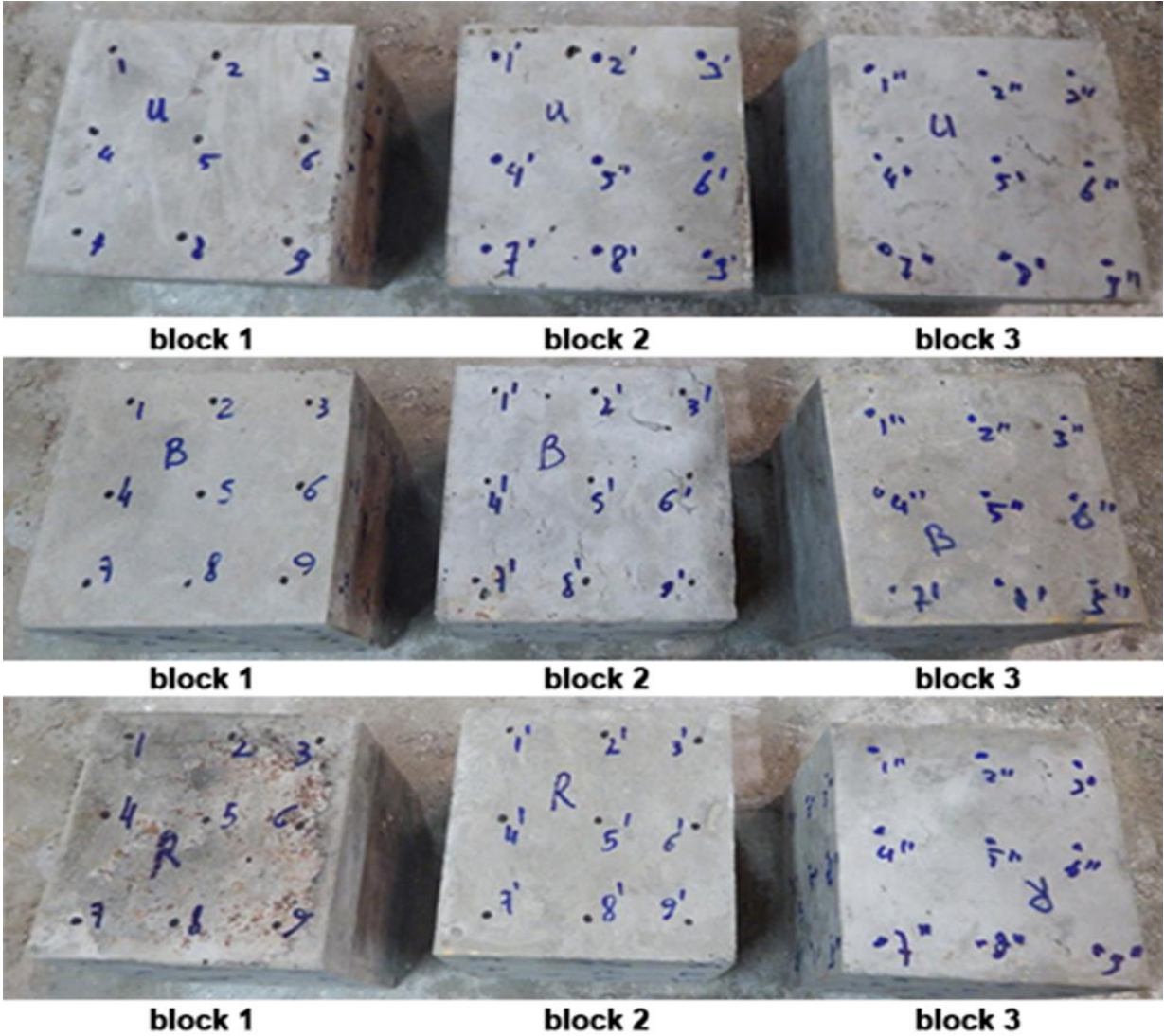

Figure 16: Three concrete testing blocks

Two Schmidt hammers (Figure 18) have been provided by the Civil Engineering Department of the University of Kathmandu. Because of the variability of the results that this device can offer, both have been used. It has been noticed that the Schmidt hammers' results varied averagely by 5 points of R (Rebound number). This has been done to check which one of the two devices was more accurate and then which one could have been used to tested the concrete directly on the site, at the village of Ratankot. So, the results from the two different Schmidt hammers have been compared to the result come out from the axial compression strength test. The measured values for the points of the blocks visible above are visible be in (Figure 107 & Figure 108 & Figure 109).



Figure 18: Schmidt hammers used for testing concrete blocks

The quality of the concrete has been revealed poor against tensile induced stresses by the application of the loads related to the Schmidt hammer; in fact, this phase induced cracks and revealed weak points that deeply describe the behaviour of the concrete against shear forces (Figure 17). The marked points (\*) have not been tested because of these remarkable damages. Furthermore, because the next phase would have included the axial compression strength test, it was not wanted to induce greater damages that would have compromised the reliability of the next tests.

To determine the relative compression strength of the concrete blocks, an average between sides, blocks and all the values provided by the two Schmidt hammers has been made. This is compared to the values of compression strength given by the Schmidt hammer producer (Figure 19).

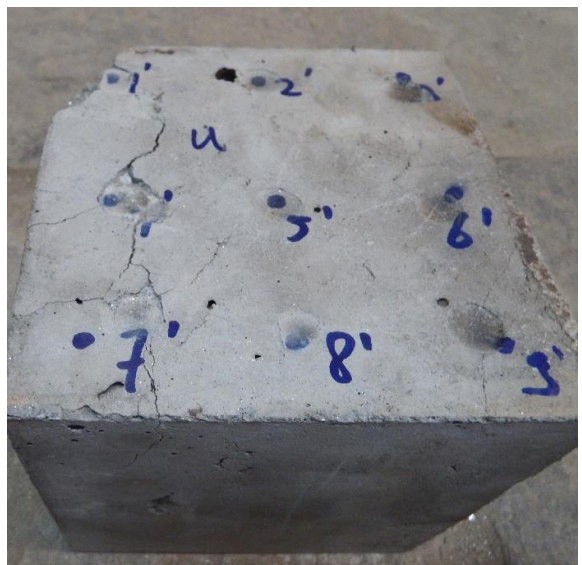
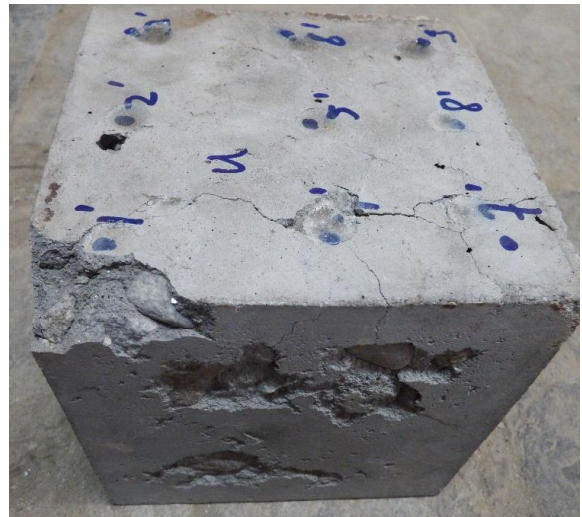

Figure 17: damages of upper and lateral side of block 2



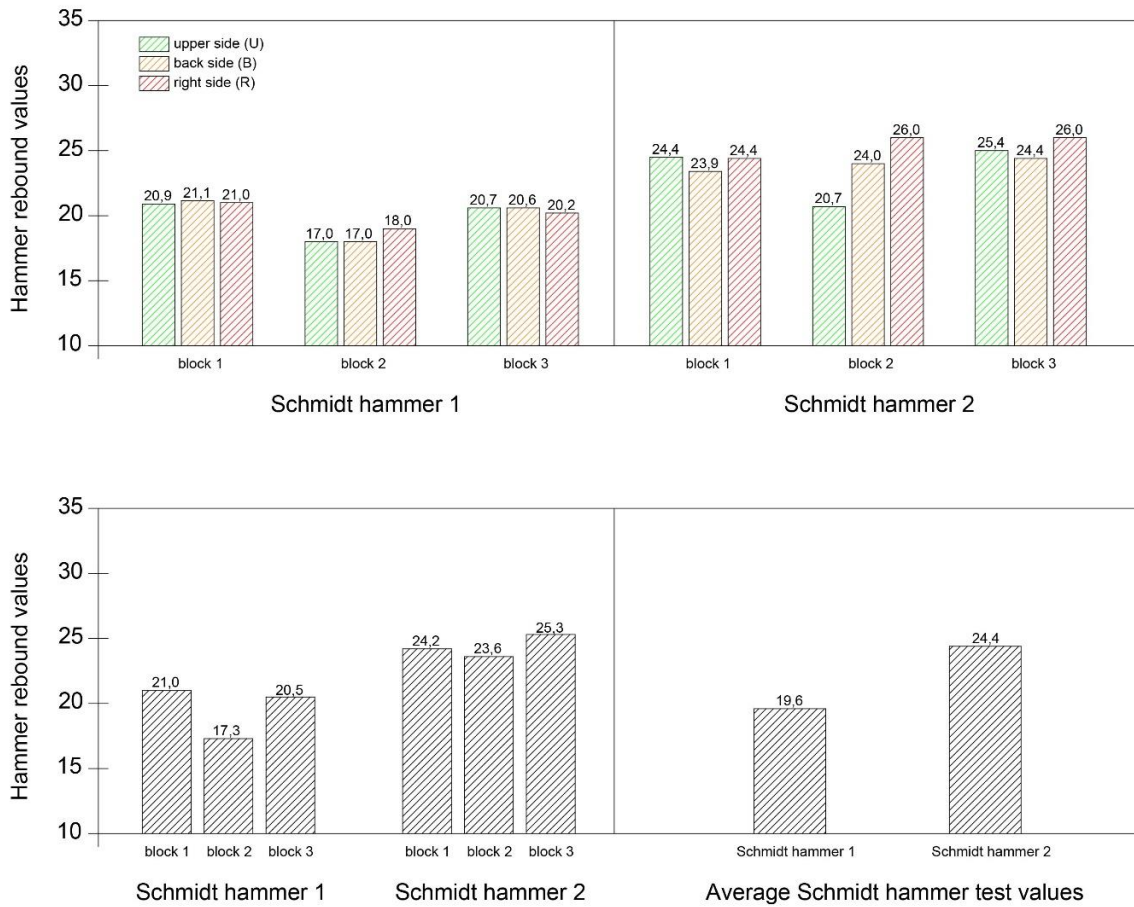

Figure 19: Compared results of the Schmidt hammers

It is noticeable that the two Schmidt hammers give results that differ for values of Rebound number of 5. The reliability of those devices will be then tested comparing these results to those coming out from the axial compression test. So far, all the two compression strength values coming from this test will be considered, and they are reported in the Appendix Figure 112.

It is then determinable the compression strength of the 7 days aged concrete blocks which have been tested, related to R equal to 20 and 24.4 respectively (Table 11).

Schmidt hammer	Rebound number average	R <sub>medium</sub> [N/mm <sup>2</sup> ]	R <sub>minimum</sub> [N/mm <sup>2</sup> ]
1	20 (approximately)	11,9	7,3
2	24,4 (approximately)	17,2	12

Table 11: Compression strength

## Axial compression strength test

After doing the Schmidt hammer test, the concrete blocks have been tested in a compression machine to determine the actual resistance of the material (Figure 20). Before testing them, concrete blocks have been weighted; all the values relative to this phase are visible in (Table 12). It must be considered that due to the low quality of the concrete and the too big dimension of the aggregates, the blocks have been already damaged by the first phase because of the induced tensile stresses coming from the application of horizontal loads of the Schmidt hammers to determine the Rebound number.

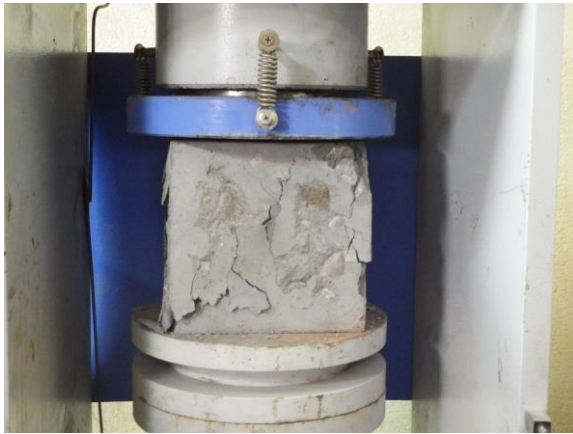

Figure 20: axial compression test on concrete block2

NR.	RATIO (c:s:a)	AGE	weight [kg]	V [mm <sup>3</sup> ]	ρ, density [kg/m <sup>3</sup> ]
1	1:2:3	7 days	8,000	3,375*10 <sup>6</sup>	2370
2	1:2:3	7 days	7,935	3,375*10 <sup>6</sup>	2350
3	1:2:3	7 days	7,780	3,375*10 <sup>6</sup>	2305
NR.	A <sub>sides</sub> [mm <sup>2</sup> ]	Breaking load [kN]	A <sub>sides</sub> [mm <sup>2</sup> ]	f <sub>R</sub> [N/mm <sup>2</sup> ]	class
1	2,25*10 <sup>4</sup>	210	2,25*10 <sup>4</sup>	9,3	M20
2	2,25*10 <sup>4</sup>	200	2,25*10 <sup>4</sup>	8,9	M20
3	2,25*10 <sup>4</sup>	230	2,25*10 <sup>4</sup>	10,2	M20

Table 12: blocks characteristics and axial compression test results

Two extra blocks have been provided by the laboratory workers to test deeper the reliability of the readings given by the Schmidt hammers. The relative characteristics and results from axial compression are shown below (Table 13).

NR.	RATIO (c:s:a)	AGE	weight[kg]	V [mm <sup>3</sup> ]	ρ, density [kg/m <sup>3</sup> ]
1 extra	1:1,5:3	more than 90 days	8,395	3,375*10 <sup>6</sup>	2490
2 extra	1:1,5:3	more than 90 days	8,250	3,375*10 <sup>6</sup>	2445
NR.	A <sub>sides</sub> [mm <sup>2</sup> ]	Breaking load [kN]	A <sub>sides</sub> [mm <sup>2</sup> ]	f <sub>R</sub> [N/mm <sup>2</sup> ]	R <sub>avg</sub>
1 extra	2,25*10 <sup>4</sup>	1400	2,25*10 <sup>4</sup>	62,2	38
2 extra	2,25*10 <sup>4</sup>	780	2,25*10 <sup>4</sup>	34,7	28

Table 13: relative characteristics and results from axial compression



In this case, there was not clear correlation between Rebound's number and compression strength of the tested blocks (Figure 19). The Rebound's numbers increase proportionally with the increasing in compression strength, showing a working behaviour when testing the structural properties of the material. However, these two extra blocks have been treated too many days and their ages are not includable into Schmidt hammer analysis. In fact, it must be said that this test is reliable only for young concrete, with ages between 2 and 54 days as specified by the indications booklet. Generally, it is used to get on-site indications on the actual properties of the made concrete after a few days of the construction processes. These values have not then been considered for the team goal.

Comparing the results coming from both the Schmidt hammer test and the axial compression test, it is visible how the values given the Schmidt hammer 1 are comparable to the latter ones, while the Schmidt hammer 2 give higher values. The goal of this research was in fact the proof that a correlation between Schmidt hammer test and axial tests exists; it is already well known the variability of the results given by the Schmidt hammers, which operation system and components are shown below (Figure 21). These are influenced by the quality of the inner working mechanism of the device as well as the age of itself. Furthermore, no information has been given about the last calibration of the rider of the hammer, that could have given not accurate results if damaged or worn.

It must be said that the Schmidt hammer test has been conducted following the information of the booklet given by the Schmidt hammer producer, Proceq Sa, Zurich, Switzerland and per ISO 9001. No plaster or cover have been applied, no to

compromise the readings of the rider. The Rebound numbers measure the compression strength of the superficial mortar of the concrete. Dust, weak points and non-resistive components on the surface, if pointed, give not accurate results. To determine the reliable compression strength values, Rebound's numbers must be relative to deeper layers, where the material results more compact and resistive. To achieve more internal components of the concrete, readings from the rider have been taken 10 times averagely, until the values became asymptotically stable. The results reported above are in fact the average of several readings done for the same point. The tests have been conducted applying the hammer pressure horizontally, per the indications given by the producer in order not to change the accuracy of the results (Figure 22).

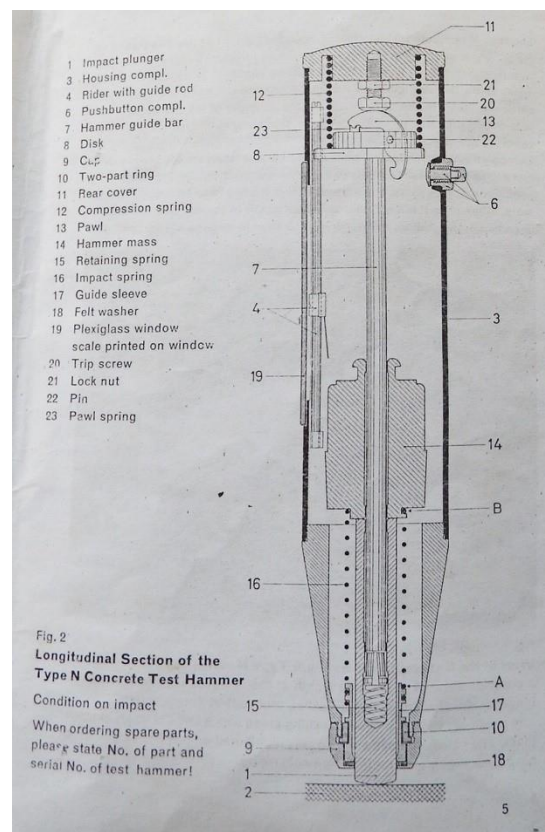

Figure 21: Schmidt hammer components



Figure 22: horizontal Schmidt hammer application

### Schmidt hammer on-site application

After validating the results given by the Schmidt hammer test, the device has been used to know the properties of the concrete directly on site. This has been the only available way to have reliable values about the compression strength of the material. It was not possible to take samples proceeding with coring operations due to the lack of adequate devices, that would have been useful to test the actual compression strength of the concrete with axial compression test. Furthermore, because the workers on site add water “by feelings” into the mix as common practice, without following a specific recipe, it was not possible to make the concrete at the laboratory as workers previously did, following the same proportions of components. Using the Schmidt hammer has then been the only feasible manner to have reliable, but still rough, properties of the concrete.

Rebound numbers have been taken using the Schmidt hammer previously validated from both vertical and horizontal elements. It has been noticed that not remarkable

different values between the two types of elements came out from the Schmidt hammer test. The same procedure described above about the use of the Schmidt hammer has been followed, recording Rebound numbers when they became constant after 5-10 times. It must be said that the concrete has been made on site 6 weeks before the test has been conducted approximately; as specified by the working description of the device, if concrete with a life span shorter than 54 days, the test still gives reliable results.

The average of the Rebound numbers recorded is 31, that is the value used to get to the relative compression strength as expressed by the graph below (Figure 23)

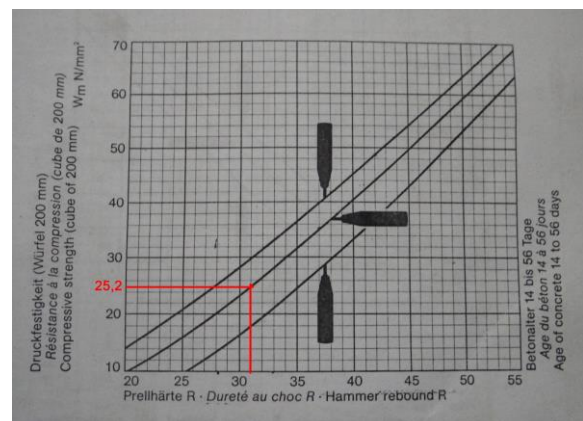

Figure 23: relation between Rebound number recorded on site and relative compression strength

As expressed by the graph and table given by the Schmidt hammer producer, Proceq Sa, Zurich, Switzerland, the compression strength of the concrete, relative to an average value of Rebound number equal to 31, is:

$$R_{ck} = 25,2 \text{ N/mm}^2;$$

$$R_{min} = 18,9 \text{ N/mm}^2;$$

that will be the values that will be used to make static calculations related to the house built in Ratankot.

### 3.3.2 Durability

As already mentioned many times, the random that the concrete mix has been made with does not give the possibility to know perfectly the proportions of components that have been used. In terms of durability, these aspects play main roles because of their influence on the properties of the concrete against degradation and damaging processes, especially talking about w/c, which influences both concrete response against durability issues and its compression strength. It was not possible know the w/c values beforehand, then it has been decided to determine empirically the w/c of the concrete as it has been made basing the values on the compression strength of the material, which came out after the Schmidt hammer test (Figure 24).

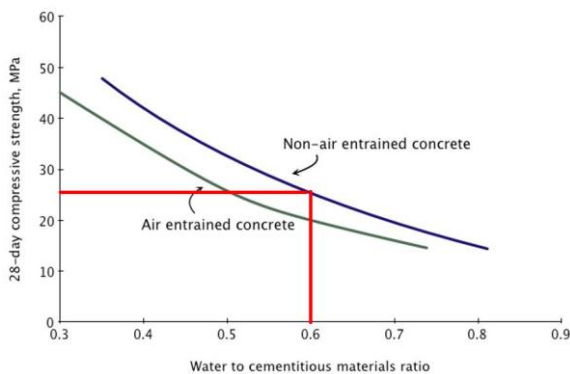

Figure 24: empirical relation between compression strength and w/c of concrete [Copuroglu, 2016]

It can be assumed that the w/c is then equal to 0.6 related to the actual compression strength of the concrete. The influence of this parameter on the durability and the properties of the material is based on wide literature focused on this topic, partly mentioned below.

### Compression strength and porosity

Higher w/c leads coarse pore distribution. Adding a certain water amount that cause the increase of w/c from 0,45 to 0,6, porosity goes up to 150% and compressive strength is decreased for 75.6% [Kim et al. 2013].

### Chloride diffusion coefficient

As dependent on the pore structure present in the inner structure of the concrete, because pores can accommodate and hold chloride and then permit their inner diffusion [Song et al. 2006], increasing w/c of the mix means deeper and bigger infiltration of chlorides into the paste, inducing durability problems firstly for the carbonation of the concrete and then for the corrosion of the steel bars. In fact, with higher w/c ratio, chloride diffusion coefficient linearly increases to 157% [Kim et al, 2013] (Figure 25).

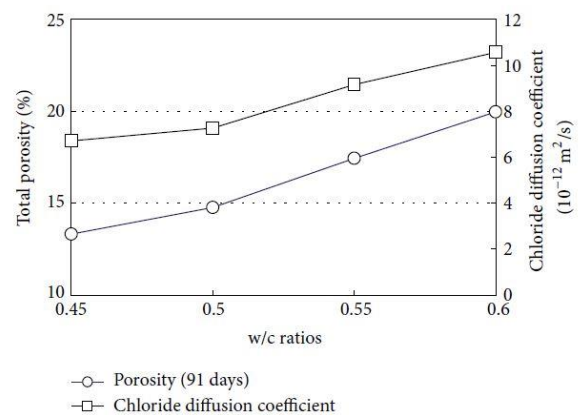

Figure 25: influence of w/c on total porosity and chloride diffusion coefficient [Kim et al. 2013]

## Air permeability

Higher the w/c of the concrete, faster and deeper is the air permeation due to the presence of coarse pores into the mortar. This increment is equal to 192% if moving from w/c of 0,45 to 0,6 [Kim et al. 2013], as even shown below (Figure 26):

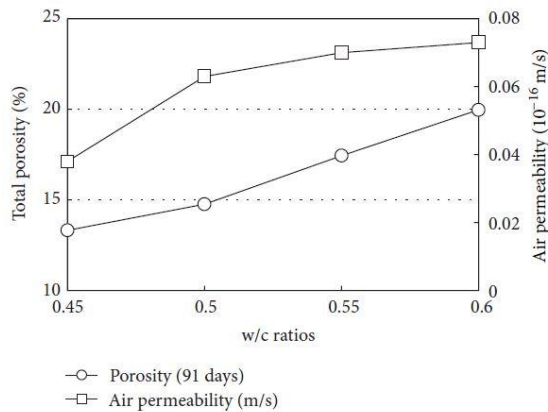

Figure 26: influence of w/c on total porosity and air permeability [Kim et al. 2013]

## Carbonation

In Nepal weather conditions, can highly change during the progress of the year. The amount of day of precipitation and the relative humidity change widely comparing dry and monsoon seasons, where relative humidity can touch values around 95% during the latter. Furthermore, CO<sub>2</sub> emissions of the country are higher than what is regulated by European legislation, especially in the urban areas. These factors, accompanied by the cyclic dry and deeply wet periods of the weather, can cause deep damages to the concrete and, furthermore, to the steel bars. In this environmental situation, it is reasonable to assume that concrete could have the chance to face carbonation problems, that can damage the surface even more than how it is already damaged by the not accurate construction processes, not being able to guarantee adequate protection to the steel bars. This will then result in corrosion of the steel

elements and loss of structural capacity of the load bearing structures.

When water and a certain amount of Carbon are simultaneously present on the surface of the material, particles can be pass through the concrete pores and getting to the inner structure of the material. On the one hand, Carbon make the pH dropping down from an alkaline situation (generally equal to 12,5-13,5) to an acid one (average of 7 with pH lowest values around 2-3, depending on the amount of C in the atmosphere); this would make the pH of the inner concrete low enough to set up corrosion processes of the steel bars, which are very sensitive to the environment acidic conditions since a pH value around 10. On the other hand, Carbon particles can also react with cement components if a pozzolanic one (PPC) has been chosen to make the mix, as in our case (Figure 27).

When mixed with water, cement starts its hydration processes, that play a main role for the whole material final performance. This step will in fact ensure that the components of the material will be kept together by Calcium Silicate Hydrate (C-S-H), which is roughly the glue that make a composite material as concrete is working as it would be a unique one. The other product of this reaction is Carbon hydro-dioxide (C-H), which does not have influence on the structural properties of the material (1). Pozzolanic materials are added to the mix to make even the left part of C-H reacting, making more C-S-H and gaining a final material that will be more compact and solid (2).



(1) Hydration reaction:

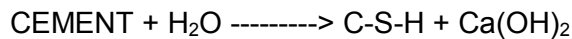

(2) Pozzolanic reaction:



The advantage of using Pozzolanic cement is the fact that more C-S-H is produced with the same amount of water that it would be necessary if Portland cement was used, or having the same performance of a Portland-cement mix with less amount of water. However, the results of the pozzolanic reaction induced by these slag materials can cause deep damages when in contact with water and C simultaneously:

in a Portland-cement mix, the C-H part after the hydration process would react with C and H<sub>2</sub>O if they get inside the material (3):

(3) Carbonation reaction for Portland-cem mix:

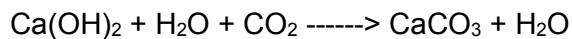

The result of this reaction, CaCO<sub>3</sub>, has bigger volume than C-H. This small volume expansion goes to fill the capillary voids that are the result of an incomplete hydration process, making the concrete compact and with less inner weak points. This would not be valid if pozzolanic components are added to the mix. In fact, C-H would be available anymore to react with entering CO<sub>2</sub> and H<sub>2</sub>O, forcing C-S-H to react with them (4):

(4) Carbonation reaction for PPC mix:



SiO<sub>2</sub>·H<sub>2</sub>O (or S-H) is a mushy result of reaction, causing high volume shrinkage and great loss of structural strength of the material. On the one hand, inner components of the concrete would not be kept together anymore, losing the cooperation between inner elements to bear the applied loads on the structure. On the other hand, the pH of the inner concrete environment would drop down to values less

than 7, creating an acidic condition that would not protect the steel bars from corrosion initiation as the concrete usually do, as basic and compact cover.



Figure 27: pozzolanic cement used to make the concrete in Ratankot

## 3.4 Steel

### 3.4.1 Steel properties

To provide tensile strength to the load bearing structure of the house in Ratankot, Fe415 steel bars have been used, both for the concrete columns and for the interlocking system of the CSEB bricks walls. The Carbon content ratio around 0,3 gives to the material higher structural performance about stress capacity, but diminishing the ductility, which plays a main role mostly in the case of earthquake. However, compared to other steel products, it still offers suitable performance even in this situation thanks to its elongation of around 14,5%. IS-1786 provides standardized properties about Fe415 as reinforcement material as below (Table 14).

Properties	characteristics	values
$f_{ck}$	Yield strength	415 N/mm <sup>2</sup>
E	Young modulus	210*10 <sup>3</sup> N/mm <sup>2</sup>
$f_{t,allowable}$	Allowable tensile stresses	230 N/mm <sup>2</sup>
$f_{c,allowable}$	Allowable compression stresses	190 N/mm <sup>2</sup>
$\nu$	Poisson's ratio	0,3
$\gamma_m$	Material safety factor	1,15
$\rho$	Density [precision of $\pm 0,5\%$ ]	7,65*10 <sup>3</sup> kg/m <sup>3</sup>

Table 14: FE415 properties

## 3.5 Discussion of results and Recommendations

### 3.5.1 Discussion of results

To make structural calculations to verify the safety of the house, characteristics of the used materials must be known. Generally, these can be assumed with a reasonable margin of error; however, looking at the state of materials on the site and after inspections about the construction steps usually followed in the current context, this was not the case. To proceed with the validation purpose, material properties needed to be estimated and analysed.

Several analyses have been conducted about concrete, as the air voids state to have a deeper understanding about the composition of the material, as well as the sieve test to better analyse the composition of the concrete. Furthermore, slump test and analysis using a Schmidt hammer have been conducted.

The air voids inspections gave indications about the wrong-doing procedures usually followed by local workers. It has been noticed that in some cases, especially talking about horizontal elements made of cast concrete, the composition of the material was deeply inhomogeneous. This can be explained by a wrong concrete compaction executed and mistakes conducted into the mixing phases, both about the composition of the concrete itself and then the mixing operations that had to be conducted. Air voids on the surface are risky for both structural and durability issues; on the one hand, the presence of air voids, both superficially and internally, reduces the actual structural strength of the material, and then of the elements themselves. On the other hand, aggressive components can be



more easily be transported inside the concrete by water flow, causing a quicker and deeper degradation of the concrete itself as well as for the embedded steel rebar's.

Sieve analyses have been conducted for aggregates directly taken from the Pipaltar site. The trend of the curve distribution of the dimensions of the aggregates result to be not so different from the advised Fuller's one. However, in many cases too big and irregular aggregates have been found. The dimension and the shape of the aggregates should be made suitable for their application into the concrete mix. This never happens in the current common doing practice, where local rocks are manually broken and then directly used into the mix. Lower compaction, creation of weak points and risk of material spalling might happen eventually due to these imperfections.

Slump test has been conducted to have a better understanding about the composition of a commonly-made concrete in Nepal. The slump class results to be S1. The high compaction of the material makes its applications easier for local workers, without needing any moulds to make structural elements. However, in this way the workability of the material drops down dramatically, and the further result is a drop in the structural strength of the elements due to inner voids, made easier to be created by the low fluidity of the mix.

Two Schmidt hammers have been provided by the Materials Laboratory at the University of Kathmandu. The purpose of having this device was to check directly on the site the strength of the used-concrete. Preliminary analysis on the reliability of these devices had to be done. This has been proved by the fact that one of the two used hammer did not give reliable results about the compression

strength of specimens that have been then tested in an axial compression strength test. On the other hand, the second hammer gave results that were comparable to those directly given by the compression strength test. The use of this device, when proved as reliable, might be useful inside the current context to check the actual on-site strength of the concrete elements, mostly because generally no information about construction operations that have been followed and the mix design are given.

w/c is the parameter that mostly influences the properties of the concrete about both durability issues and structural performance. An adequate level of attention during mix preparation can highly increase the quality of the material. The quality of the concrete includes the ability of the material to fit the purpose that it has been made for. Deep damages and changes into the inner structure can firstly reduce the structural performance in a working service situation, changing the structural response when permanent and additional loads are applied, and secondly the material could not be able to bear solicitations coming from earthquake forces anymore. The processes that have been done, as the amount of water putted into the mix "by feelings" and without following specific recipe, do not give adequate final properties and they are still too rough for the material, as main load bearing component. Adequate information must be given beforehand to the workers to make and then cure the material in such a way that final properties will not be compromised.

Looking at the loads applied on the concrete structure and thanks to the modest complexity of the house itself, the compression strength might offer a static adequate response even if still low compared to what is used in the practice in

the Western countries (where generally concrete is prescribed as minimum C25/30). However, it must be said that the other main function of the material is even to cover the steel bars, protecting them from corrosion mechanism with a continuous and compact surface. This aspect is made even more important in this situation where the house should bear huge earthquake forces, causing high tensile stresses on the structure. The high w/c and the relative high porosity and chloride diffusion coefficient can easily compromise the response of the steel bars, causing losses of material and strength. For the reasons explained above, it is necessary that the composition of the concrete and then its conformation will be changed adequately, keeping lower w/c and fixed components proportions and ensuring a certain level of attention for the on-site operations that must be done as for mixing and curing.

BAMBOO:

CSEB:

### 3.5.2 Recommendations

Several operations could be taken to improve the quality of the concrete, to prevent or at least diminish any structural capacity drops or durability issues. These can be grouped in two main parts: indications about the composition of the material, regarding the components that are used into the mix, and the on-site construction operations that should be followed.

For the first group of recommendations, enough attention must be paid at the quality of the components used into the mix. Portland cement would be preferred to Pozzolanic cement thanks to its higher strength and the lower risks to be attacked by carbonation processes. The ratio between the cement, sand and aggregates

should be checked directly on the site and not left on the workers' feelings, as well as the water cement ratio. Aggregates should be as round as regular as possible, and both aggregates and sand should be sieved before being putted into the concrete mix. Finally, the proportions of components should be beforehand agreed and measured. A receipt provided by a concrete expert should be strictly followed, and on site supervision would be an added value to ensure a certain high quality of the final material.

For the latter group, concrete making operations should be supervised during their development. It has been noticed the common trend of local workers to base their actions on their expertise and knowledge, which sometimes reveals to be inadequate. Manual mixing requires long time and effort, and it should be carried on until the highest homogeneity of the mix has been reached. Supervision should be preferable to check whether the construction procedures are followed as prescribed. Daily concrete operations should be followed, wetting the surface of the elements; the required curing time should be 28 days, but looking at the general trend it would be already preferable to ensure a 7-days curing procedure. While concrete is treated, the construction should be stopped and carried on only once the treatment is finished. Applications of upper layers of bricks during the treatment of the concrete should be avoided. Finally, making concrete elements manually is made easier by the high compaction of the concrete itself. However, moulds should be used to shape the elements, infilling the space made by the moulds with the mixture and waiting a reasonable time to let the compaction process happen. This would make the geometrical cross section of the elements more regular and stable than making elements manually directly on the top of bricks layers without any boundaries.

# PART II. THE DESIGN VALIDATION



# 4 Loads

## 4.1 Loads determination

To determine the static resistance of the model house built in the village of Ratankot, static loads have been applied following the guidelines and indications given by the Indian Building Code IS 875:1987 and the Nepalese Building Code NBC 100 and others. The lack of useful information included in these two codes has been replaced consulting the Eurocode, like for example the characteristic value of the snow load at the ground level.

### 4.1.1 Imposed loads

The NBC 103 – occupancy loads determination totally refers to the IS 875:1987 part 2 to proceed about the determination of the imposed loads (I) on the structure depending on the function of the building itself. For the destination of the house built in Ratankot, *residential*, the minimum reference values that must be used to proceed in favour of safety are reported below (Table 15):

TABLE 1 IMPOSED FLOOR LOADS FOR DIFFERENT OCCUPANCIES  
(Clause 3.1, 3.1.1 and 4.1.1)

Sl No. (1)	Occupancy Classification (2)	Uniformly Distributed Load (UDL) (3) kN/m <sup>2</sup>	Concentrated Load (4) kN
i) RESIDENTIAL BUILDINGS			
a) Dwelling houses:			
1)	All rooms and kitchens	2.0	1.8
2)	Toilet and bath rooms	2.0	—
3)	Corridors, passages, staircases including fire escapes and store rooms	3.0	4.5
4)	Balconies	3.0	1.5 per metre run concentrated at the outer edge

\*Guide for requirements of low income housing.

Table 15: imposed loads for residential occupancy

while for sloping roof with slop greater than 10° it must be considered an applied load of 0,75 kN/m<sup>2</sup> with a reduction of 0,02 kN/m<sup>2</sup> for every degree increase of inclination but still higher than the minimum value fixed at 0,4 kN/m<sup>2</sup>. This value is relative to those roofs

where the access is allowed only for maintenance. Because the pilot house has been built with a bamboo roof structure with a pendency of 24,51°, the relative imposed load on the roof will be:

$$I_{\text{roof}} = 0,75 \text{ kN/m}^2 - 0,02 \text{ kN/m}^2 * (24^\circ - 10^\circ) = 0,47 \text{ kN/m}^2$$

### 4.1.2 Wind loads

To determine the wind forces acting on the structural elements the NBC104 and IS 875:1987 part 3 have been followed, according to the local procedure. The wind loads must be considered as acting only on the whole house and the vertical elements of that, according to the nature of the load itself, pushing almost totally along the horizontal direction.

The first step to do to determine the loads is determining the Design wind speed ( $V_z$ ) relative to the considered area. It must be noticed that NBC refers completely to the Indian Standard Code, which does not include any specifications for Nepalese area. Then, per what is explained in the NBC, the probability, topography and safety coefficients must be taken related to the Indian area closest to Nepal, remarked with a green colour (Figure 28).

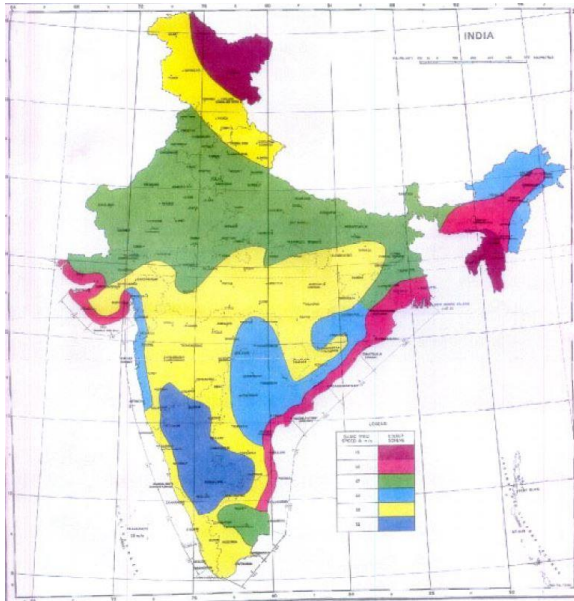

Figure 28: distinction of Indian areas for different wind characteristics

The Design wind speed must be calculated as follows:

$$V_z = k_1 * k_2 * k_3 * V_b$$

where:

$V_b$  = Basic wind speed [m/s];

$k_1$  = probability factor;

$k_2$  = terrain, height and size factor;

$k_3$  = topography factor;

NOTE: according to the reference Indian area (green one, Figure 26), the basic wind speed is equal to 47 m/s.

### Probability factor

The determination of the probability factor  $k_1$  is based on a statistical approach provided by IS 875:1987 part 3, and it is function of the basic wind speed  $V_b$  linked to the considered area. It is assumed as a standard condition that the service life of the house is fixed as 50 years. According to the reference values (Table 16), the probability factor is then equal to 1,0.

CLASS OF STRUCTURE	MEAN PROBABLE DESIGN LIFE OF STRUCTURE IN YEARS	$k_1$ FACTOR FOR BASIC WIND SPEED ( $m/s$ ) OF					
		33	39	44	47	50	55
All general buildings and structures	50	1.0	1.0	1.0	1.0	1.0	1.0
Temporary sheds, structures such as those used during construction operations (for example, formwork and falsework), structures during construction stages and boundary walls	5	0.82	0.76	0.73	0.71	0.70	0.67
Buildings and structures presenting a low degree of hazard to life and property in the event of failure, such as isolated towers in wooded areas, farm buildings other than residential buildings	25	0.94	0.92	0.91	0.90	0.90	0.89
Important buildings and structures such as hospitals communication buildings / towers, power plant structures	100	1.05	1.06	1.07	1.07	1.08	1.08

Table 16: Risk coefficients  $k_1$  for different classes of structures in different wind speed zones

### Terrain, height and size factor

The  $k_2$  factor is defined as function of the *Category* and the *Class* of the considered building. While the first parameter is referred to the boundary conditions of the location of the building, the second one is linked to its dimensional characteristics. The house in Ratankot is defined as:

Category 1: exposed open terrain with few or no obstructions and in which the average height of any object surrounding the structure is less than 1,5 m;

Class A: Structures and/or their components having maximum dimension (greatest horizontal or vertical dimension) less than 20 m;

According to the IS 875:1987 part 3 (Table 17) and to the dimension of the house, the  $k_2$  factor is then equal to 1,05 (referred to a height less than 10 m):

HEIGHT	TERRAIN CATEGORY 1 CLASS			TERRAIN CATEGORY 2 CLASS			TERRAIN CATEGORY 3 CLASS			TERRAIN CATEGORY 4 CLASS			
	A	B	C	A	B	C	A	B	C	A	B	C	
m	(1)	(2)	(3)	(4)	(5)	(6)	(7)	(8)	(9)	(10)	(11)	(12)	(13)
10	1.05	1.03	0.99	1.00	0.98	0.93	0.91	0.88	0.82	0.80	0.76	0.67	0.67
15	1.09	1.07	1.03	1.05	1.02	0.97	0.97	0.94	0.87	0.80	0.76	0.67	0.67
20	1.12	1.10	1.06	1.07	1.05	1.00	1.01	0.98	0.91	0.80	0.76	0.67	0.67
30	1.15	1.13	1.09	1.12	1.10	1.04	1.06	1.03	0.96	0.97	0.93	0.83	0.83
50	1.20	1.18	1.14	1.17	1.15	1.10	1.12	1.09	1.02	1.10	1.05	0.95	0.95
100	1.26	1.24	1.20	1.24	1.22	1.17	1.20	1.17	1.10	1.20	1.15	1.05	1.05
150	1.30	1.28	1.24	1.28	1.25	1.21	1.24	1.21	1.15	1.24	1.20	1.10	1.10
200	1.32	1.30	1.26	1.30	1.28	1.24	1.27	1.24	1.18	1.27	1.22	1.13	1.13
250	1.34	1.32	1.28	1.32	1.31	1.26	1.29	1.26	1.20	1.28	1.24	1.16	1.16
300	1.35	1.34	1.30	1.34	1.32	1.28	1.31	1.28	1.22	1.30	1.26	1.17	1.17
350	1.37	1.35	1.31	1.36	1.34	1.29	1.32	1.30	1.24	1.31	1.27	1.19	1.19
400	1.38	1.36	1.32	1.37	1.35	1.30	1.34	1.31	1.25	1.32	1.28	1.20	1.20
450	1.39	1.37	1.33	1.38	1.36	1.31	1.35	1.32	1.26	1.33	1.29	1.21	1.21
500	1.40	1.38	1.34	1.39	1.37	1.32	1.36	1.33	1.28	1.34	1.30	1.22	1.22

NOTE 1 — See 5.3.2.2 for definitions of Class A, Class B and Class C structures.

NOTE 2 — Intermediate values may be obtained by linear interpolation, if desired. It is permissible to assume constant wind speed between 2 heights for simplicity.

Table 17:  $k_2$  factors to obtain design wind speed variation with height in different terrains for different classes of building/structures



It must be said that the presence of a remarkable slope next to one of the four walls of the house could change the classification of that specific structural element from 1 to 3, with relative  $k_2 = 0,91$ . However, the  $k_2$  will be kept equal for all the vertical members, proceeding in favour of safety taking the highest one between the two ( $k_2 = 1,05$ ).

### Topography factor

The topography factor  $k_3$  considers the morphology of the area where the house is located and the presence of cliffs and hills, according to the IS 875:1987 part 3 – Appendix C. According to the geological situation of the site and not following the whole determination procedure of this factor as indicated in the document mentioned above, it is reasonable to take a value for the topography factor  $k_3$  equal to 1,0.

The Design wind speed is then calculated as:

$$V_z = k_1 * k_2 * k_3 * V_b = 1,0 * 1,05 * 1,0 * 47 \text{ m/s} = 49,35 \text{ m/s}$$

### Design wind pressure

Determining the design wind speed  $V_z$  is then possible calculating the design wind pressure  $p_z$ . It must be said that the wind that the application of horizontal wind loads on structural elements is function of the height of the elements themselves. Up to 10 m high, the wind forces have gradient development, from an insignificant starting point at the bottom to the biggest one at the top. Above 10 m high, the wind pressure is assumed constant. However, as advised by the IS 875:1987, it is reasonable to proceed in favour of safety, assuming a constant load application on the structural elements taking the maximum (or the average) value of wind

pressure. The design wind pressure  $p_z$  is given as:

$$p_z = 0,6 * V_z^2$$

where:

$V_z$  = design wind speed [m/s] = 49,35 m/s;

0,6 = coefficient depending on several factors including atmospheric pressure, temperature and density of the air usually present in the Indian environment [ $\text{kg/m}^3$ ];

It follows that  $p_z = 0,6 \text{ kg/m}^3 * (49,35 \text{ m/s})^2 = 1461,25 \text{ kg/(m*s}^2) = 1,46 \text{ KPa}$

### Wind load

When the pressure has been determined, it is possible to calculate the wind load applied on a structural element, which is determined as follows:

$$F = (C_{pe} - C_{pi}) * A * p_z$$

where:

$F$  = wind load [kN or kN/m depending on punctual or linear load application];

$C_{pe}$  = external pressure coefficient;

$C_{pi}$  = internal pressure coefficient;

$A$  = area of the structural element [ $\text{m}^2$ ];

$p_z$  = design wind pressure [kPa];

NOTE: the dimension of the considered structural element ( $A$ ) can be changed to one dimensional [m] when considering one dimensional element and linear load application [kN/m];



## External pressure coefficient

According to the IS 875:1987 part 3, a difference between structural elements has been made to calculate the relative applied wind loads depending on their dimension and their horizontal and vertical shape, as done between walls and roofs. This is translated in different given external and internal pressure coefficients. These values are influenced according to the dimensions (and their ratio with each other) of the house, reported below (Figure 29):

*Plan:*

$$l_1 = 5,7 \text{ m}; l_2 = 5,25 \text{ m}; A = 29,9 \text{ m}^2;$$

*Elevation:*

$$h_{\text{walls}} = 2,7 \text{ m}; h_{\text{top roof}} = 4,0 \text{ m};$$

*Pendency:*

$$(h_{\text{top roof}} - h_{\text{walls}})/(l_1/2) = \text{tg } \alpha = 0,4561$$

$$\text{----} \rightarrow \alpha = 24,52^\circ;$$

$$\text{Ratios: } h_{\text{walls}}/l_1 = 0,47;$$

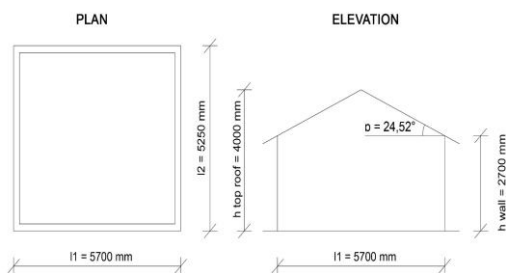

Figure 29: dimensions of the house in Ratankot

Depending on the dimension and characteristics mentioned above, it is possible to determine the  $C_{pe}$  coefficients for the two building elements consulting the given figures (Figure 30 & Figure 31).

TABLE 4 EXTERNAL PRESSURE COEFFICIENTS ( $C_{pe}$ ) FOR WALLS OF RECTANGULAR CLAD BUILDINGS (Class 6.2.2.1)

BUILDING HEIGHT RATIO	BUILDING PLAN RATIO	ELEVATION	PLAN	WIND ANGLE $\theta$	C <sub>pe</sub> FOR SURFACE				LOCAL C <sub>pe</sub>
					A	B	C	D	
$l_1 < \frac{l_2}{2}$	$\frac{l_1}{l_2} < \frac{1}{2}$			degrees					-0,8
				0	+0,7	-0,2	-0,5	-0,5	
				90	-0,5	-0,5	+0,7	-0,2	
$\frac{l_1}{l_2} < \frac{1}{2}$	$\frac{3}{2} < \frac{l_1}{l_2} < 4$			degrees					-1,0
				0	+0,7	-0,25	-0,6	-0,6	
				90	-0,5	-0,5	+0,7	-0,1	

Figure 30: external pressure coefficients for walls of rectangular clad buildings

For the loads applied on the walls, only the worst scenario will be considered, proceeding in favour of safety but still not making differences between the different directions of the wind. In the actual state-of-art of the house then, the relative  $C_{pe}$  is taken equal to 0,7.

TABLE 5 EXTERNAL PRESSURE COEFFICIENTS ( $C_{pe}$ ) FOR PITCHED ROOFS OF RECTANGULAR CLAD BUILDINGS (Class 6.2.2.2)

BUILDING HEIGHT RATIO	Roof ANGLE $\theta$	WIND ANGLE $\theta$				LOCAL COEFFICIENTS			
		EF	GH	EG	FH				
$l_1 < \frac{l_2}{2}$	degrees								
	5	-0,6	-0,4	-0,6	-0,4	-2,0	-2,0	-1,0	-
	10	-0,9	-0,4	-0,8	-0,4	-1,4	-1,2	-1,0	-1,0
	20	-1,2	-0,4	-0,8	-0,4	-1,0	-1,0	-1,0	-1,0
	30	-0,4	-0,4	-0,7	-0,6	-1,0	-1,4	-	-1,0
	45	0	-0,4	-0,7	-0,6	-1,0	-1,4	-	-1,0
60	+0,5	-0,5	-0,7	-0,6	-1,0	-1,4	-	-1,0	
	90	+0,7	-0,8	-0,7	-0,6	-	-	-	-1,1

Figure 31: External pressure coefficients for pitched roof of rectangular clad buildings

As it has been done for the walls, even regarding the roof only the worst scenario will be considered proceeding in favour of safety but still not making differences between the different directions of the wind. In the actual state-of-art of the house then, the relative  $C_{pe}$  is taken equal to -1,2 considering the whole structure (left side of the table) instead of local coefficients (right side).

## Internal pressure coefficient

As explained by the IS 875:1987 part 3, two different scenarios for wind loads should be considered, differing from the value of the internal pressure coefficient  $C_{pi}$  that can range between  $\pm 0,2$ . It can be noticed how a value of  $C_{pi} = -0,2$  makes the  $\Delta C_p$  higher regarding the walls, while for roofs the same happens with a value of  $C_{pi} = 0,2$ . In order to proceed in favour of safety, only these two scenarios will be considered.

It is then possible to calculate the applied wind loads on the structural elements, that are:

$$F_{walls} = (C_{pe} - C_{pi}) * A * p_z = (0,7 - (-0,2)) * A * 1,46 \text{ kPa} = 1,314 \text{ kPa per m}^2 \text{ of wall considered;}$$

$$F_{roof} = (C_{pe} - C_{pi}) * A * p_z = (-1,2 - 0,2) * A * 1,46 \text{ kPa} = 2,04 \text{ kPa per m}^2 \text{ of roof considered;}$$

NOTE: the wind load applied on the roof,  $F_{roof}$ , must be considered as horizontal load, not increasing the vertical loads applied on the load bearing reinforced concrete beams.

### 4.1.3 Snow load

According to the IS 875:1987 part 4, which indications must be followed as indicated by the NBC 106, the determination of the snow load (S) is based on nominal values provided by the local authorities, due to the lack of reliable data about the subject in the country. The snow load is then determined as follows:

$$S = \mu * S_0$$

where:

S = Snow load [ $\text{N/m}^2$ ];

$\mu$  = shape coefficient;

$S_0$  = Snow load at the ground level;

The shape coefficient  $\mu$  is determined by tables provided by the IS 875:1987 part 4 as follows (Table 18).



	Simple Flat and Monopitch Roofs	Simple Pitched Roofs (Positive Roof Slope)*
		
		
$0^\circ < \beta \leq 30^\circ$		$\mu_2 = \mu_1 = 0,8$
$15^\circ < \beta \leq 30^\circ$	$\mu_1 = 0,8$	$\mu_2 = 0,8 + 0,4 * \left(\frac{\beta - 15}{15}\right)$ $\mu_1 = 0,8$
$30^\circ < \beta < 60^\circ$	$\mu_1 = 0,8 * \left(\frac{60 - \beta}{30}\right)$	$\mu_2 = 1,2 * \left(\frac{60 - \beta}{30}\right)$ $\mu_1 = 0,8 * \left(\frac{60 - \beta}{30}\right)$
$\beta > 60^\circ$	$\mu_1 = 0$	$\mu_2 = \mu_1 = 0$

Table 18: shape coefficients for different roof configurations

The higher value between the two shape coefficients  $\mu_1$  and  $\mu_2$  must be used to determine the snow load applied on a surface. While  $\mu_1 = 0,8$ ,  $\mu_2$  can be determined taking directly into account the pendency of the roof ( $24,51^\circ$ ), resulting in:

$$\mu_2 = 0,8 + 0,4 * ((24,51 - 15) / 15) = 1,05$$

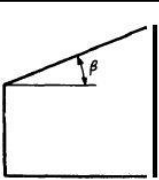
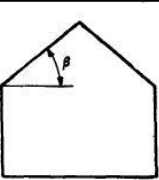
Inside the IS 875:1987 part 4, as well as into the NBC 106, no data is given about the snow load at the ground floor. In order to proceed into the determination of the live loads on the house, it has decided to assume that the snow load at the ground

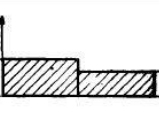
level is equal to the characteristic value of snow loads used into the Eurocode, equal to 1,5 kN/m<sup>2</sup> but still keeping the shape factor provided by the IS 875:1987 part 4, equal to 1,05. The relative snow load will then be:

$$S = \mu_2 * S_0 = 1,05 * 1,5 \text{ kN/m}^2 = 1,575 \text{ kN/m}^2;$$

#### 4.1.4 Earthquake loads

As specified into the NBC 105 – Seismic Design of buildings, the static calculations about the structural performance of a certain building must consider the application of extra static loads due to earthquake probability to happen. This load is then increased by safety factors for different load combinations, depending on the specific situation itself. The addition of the earthquake load,  $W_i$ , depends on the heaviness of the live loads [Table 25]:

Design Live Load	Percentage of Design Live Load
Up to 3 kPa	25
Above 3 kPa and for vehicle garages	50
For Roofs	NIL

*Table 19: Increasing percentage of live loads due to earthquake factor*

The sum of the vertical live loads,  $LL_i$ , related to the load bearing structures is equal to the sum of the imposed load on the roof and the snow load, then:

$$LL_i = I_{\text{roof}} + S = 0,47 \text{ kN/m}^2 + 1,575 \text{ kN/m}^2 = 2,1 \text{ kN/m}^2;$$

Then the earthquake load,  $E$ , will be equal to:

$$E = 2,1 \text{ kN/m}^2 * 0,25 = 0,525 \text{ kN/m}^2$$

NOTE: the wind load, as completely considered as a horizontal load, is not considered in this determination phase of the actual loads on the horizontal and vertical load bearing elements. However, it will be considered when the static calculations will be made for the roof structure and for the bending resistance of the vertical elements.

## 4.2 Structural preliminary analysis

Before starting static calculations on the house, an on-site inspection has been done to have more information about the structural capacity of the structures and the load path that did must be considered. The house has been made of reinforced concrete horizontal and vertical elements, CSEB bricks infilling walls and bamboo roof. Three concrete horizontal bents have been built per each external wall of the house. The four reinforced concrete columns have been putted at the corners of the square shape of the house. A visual overview of the state of the house is visible below (Figure 32, Figure 33 & Figure 34).

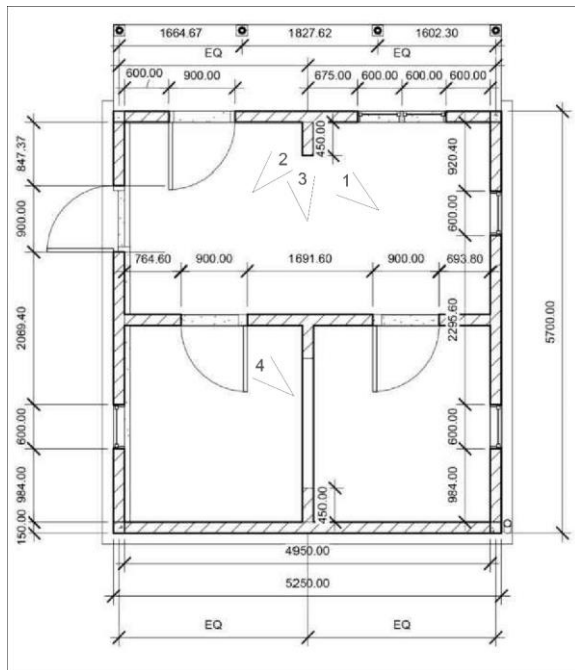

Figure 32: top overview of the model house



Figure 33: inside view of the model house



Figure 34: inside view of the model house

The load bearing capacity of the house has been studied. On-site analysis has been conducted, trying to understand which are the most reasonable load path that elements have to carry and which elements work as load bearing. From the beginning, big effort has been putted to understand if the load bearing function for the house would have been made by the reinforced concrete skeleton or by the CSEB brick walls.

It easily visible how the loads from the roof are mostly carried by the central walls, visible in the Pic.3 above. At the edges of the wall no columns are present. On the one hand, this could mean that the forces are transmitted from the central beam to the two at the perimeter of the house, transmitting then the forces to the corners, where columns have been built. On the other hand,

this could mean that actually the beam, visible in the Pic.3, would not be enough strong and big to bear the stresses and that the loads from the roof are then carried by the CSEB bricks wall. The latter scenario has been considered as the most feasible between the two, firstly because of the limited dimensions of the cross section of the beam (15 cm x 15 cm), secondly because of the limited amount of steel bars that has been putted into the concrete as reinforcement (2 $\phi$ 12 for each upper and bottom side of the element) and last but not least for the high span that the beam has to cover, equal to 5,25 m. This scenario can be explained as follows: the load bearing function for the house would be provided by the reinforced concrete elements, but by the CSEB brick walls, while the concrete elements would work as transmitting elements between the walls of the house in an earthquake situation. The presence of this elements, even if as not load bearing, is firstly indicated by the building catalogue given by the Nepali government and then it is advised in order to improve the earthquake resistance of the wall structure.

It was not possible to know beforehand which elements worked as load bearing structure. In order to understand that, the load bearing capacity of the beam has been analysed, considering that firstly as it was load bearing. If the calculation proved the lack of structural capacity of the beam, it would have meant that the second scenario of the two described above will be the most reliable.

Following the indication given by the NBC 105, different load combination for working stress method and ultimate stress method must be calculated. Between the different combinations, the worst one must be ensured by static calculations that could prove the reliability of the structural

performance of the structural element. The different load combinations are:

*Working stress method:*

- a) DL + LL + E;
- b) 0,7 DL + E;
- c) DL + SL + E;

*Ultimate stress method:*

- a) DL + 1,3 LL + 1,25 E;
- b) 0,9 DL + 1,25 E;
- c) DL + 1,3 SL + 1,25 E;

Due to the fact that  $LL = 0,47 \text{ kN/m}^2 < SL = 1,575 \text{ kN/m}^2$ , it is easily noticeable that the most dangerous and heavy loads combination is the c) of the ultimate stress method.

The additional and live loads have been already determined in the previous section of the report. About the permanent loads, the beam must carry loads from several elements laid on the top of the load bearing element (Figure 35), as:

- the bamboo roof;
- the reinforced concrete upper bent;
- two layers of CSEB bricks;

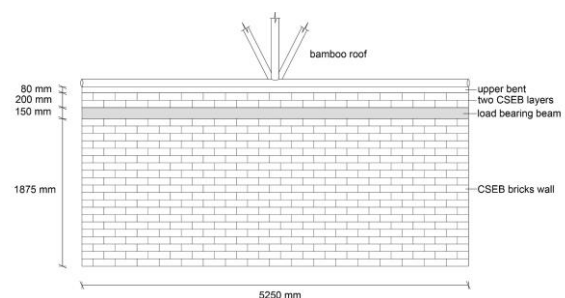

Figure 35: elevation of the most loaded beam



## 4.2.1 Weight determination

### Bamboo roof

To determine the weight of the roof, an average of the thickness and diameter of all the bamboo sticks has been made: it has been assumed, after previous reliable measurements, that the thickness of the bamboo is equal to 15 mm while the whole diameter is equal to 65 mm. Then the total length of the sticks has been summed. The final volume of bamboo used to build the roof is equal to around  $0,55 \text{ m}^3$ , with a density of  $810 \text{ kg/m}^3$ . On the top of the roof is then added a layer of corrugated steel plates to cover the whole surface. The final load of the bamboo and corrugated steel roof is equal to around 510 kg, as visible looking at the bamboo roof model present in this report. The total bamboo roof distributed load,  $RL$ , will be:

$$RL = 5100 \text{ N} / (5,25 \text{ m} * 5,7 \text{ m}) = 0,170 \text{ kN/m}^2$$

Due to the triangular shape of the roof and the huge concentration of bamboo sticks on the top of the most loaded beam, it is reasonable to say that  $2/3$  of the whole weight of the roof are carried by the beam, with relative live and additional loads on that. The loads from the roof that must be carried by the beam will be then linearly:

$$RL = 0,170 \text{ kN/m}^2 * 5,7 \text{ m} * 2/3 = 0,646 \text{ kN/m}$$

$$SL = 1,575 \text{ kN/m}^2 * 5,7 \text{ m} * 2/3 = 5,985 \text{ kN/m}$$

$$E = 0,525 \text{ kN/m}^2 * 5,7 \text{ m} * 2/3 = 1,995 \text{ kN/m}$$

### Upper bents

At the top of the beam is laid a reinforced concrete bent that should be supposed to distribute more the loads on the structure, improving the structural capacity of the house mostly in an earthquake situation, as indicated by the NBC. The cross section of this element is 8 cm high x 15 cm wide, extended for the whole length of the beam, 5.25 m. Assuming a reinforced concrete specific self-weight equal to  $2400 \text{ kg/m}^3$ , the final distributed load from the upper bent to the beam will be:

$$U_bL = (0,08 \text{ m} * 0,15 \text{ m}) * (2400 \text{ kg/m}^3) = 28,8 \text{ kg/m} = 0,288 \text{ kN/m}$$

### CSEB bricks

Two more layers of CSEB bricks are applied on the beam for the whole length of the beam itself. As already shown in the material analysis section, the dimension of these elements is 300 cm x 150 cm x 100 cm per each one, with an average density equal to  $1830 \text{ kg/m}^3$ . The final distributed load from these two layers of CSEB bricks,  $B_{\text{CSEB}}L$ , will be then:

$$B_{\text{CSEB}}L = (0,15 \text{ m} * 0,1 \text{ m}) * (1830 \text{ kg/m}^3) = 27,45 \text{ kg/m} = 0,2745 \text{ kN/m}$$

### Beam self-weight

As already done for the reinforced concrete upper bent, the same mechanism will be applied to determine the self-weight of the reinforced concrete load bearing beam, which has cross sectional dimensions of 15 cm wide per 15 cm high. The final distributed self-weight of the beam,  $S_wL$ , will be then:

$$S_wL = (0,15 \text{ m} * 0,15 \text{ m}) * (2400 \text{ kg/m}^3) = 54 \text{ kg/m} = 0,540 \text{ kN/m}$$



Calculating all the weights of the materials present on the top of the beam, it is now possible to determine the all deal load, DL, applied, that will be then:

$$DL = RL + U_bL + B_{CSEB}L + S_wL = 0,646 \text{ kN/m} + 0,288 \text{ kN/m} + 0,2745 \text{ kN/m} + 0,540 \text{ kN/m} = 1,75 \text{ kN/m}$$

The worst scenario of load combination, c) of the ultimate stress method, imposes a linear load on the beam, q, equal to:

$$Q = DL + 1,3 SL + 1,25 E = 1,75 \text{ kN/m} + 1,3 * 5,985 \text{ kN/m} + 1,25 * 1,995 \text{ kN/m} = 12,02 \text{ kN/m}$$

that is the linear load value that will be used to make static calculations about the resistance of the beam.

#### 4.2.2 Main beam static scheme and calculations

After determining the loads applied on the beam, with relative safety coefficients, the static load bearing capacity of the beam has been studied. Due to the lack of columns, the beam could not have been considered as simply supported at the boundaries by vertical elements. Two perpendicular beams are present at the edges of the one considered. Those are simply supported at their edges by vertical columns, located at the four corners of the square shape of the house. It has not been possible getting deeper information about the connection between the considered beam and those at its edges. However, because of the boundary conditions and the layout of the structure, it has been reasonable to assume that the beams were connected in such a way that all the forces were transmitted from

the inner beam to those at the edges, and then to the columns. This means that the connection between the horizontal elements provided the transmission of all the forces that the main beam was subjected to. The static scheme of the considered beam will be then as follows (Figure 36).

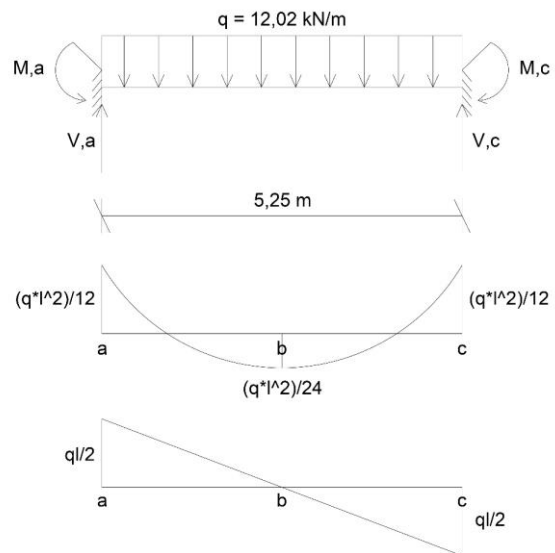

Figure 36: static scheme of the considered beam - most loaded one

In this case the load bearing capacity of the beam, as it has actually been built, has been referred to the bending stress in the middle of the span. According to the static scheme above, the bending load that the beam should be supposed to bear,  $M_{Ed,b}$ , is equal to:

$$M_{Ed,b} = (q * l^2) / 24 = (12,02 \text{ kN/m} * (5,25 \text{ m})^2) / 24 = 13,80 \text{ kN*m}$$

It must be said that this bending load is the maximum one that stresses the bottom reinforcement bars of the concrete beam, but it is still not the maximum one, as it can be noticed looking at the bending values for the top sides at the edges of the beam. However, it has been decided to proceed making calculations on the load bearing capacity of the cross section at the point "b": if this will not be verified, subsequently

neither the two points at the edges would be due to the higher bending loads acting there.

The load bearing capacity of the structural element will be analysed calculating the bending resistance of the cross section,  $M_{RD}$ , and comparing that with the applied bending force,  $M_{Ed}$ . If  $M_{RD} > M_{Ed}$ , the stresses caused by the load application will be carried by the

structural element. The reinforced concrete beam has a square shape of 150 mm x 150 mm, with the same amount of reinforcement bars for upper and bottom side of the cross section ( $2\phi 12$ ,  $226 \text{ mm}^2$ , per each side) (Figure 37).

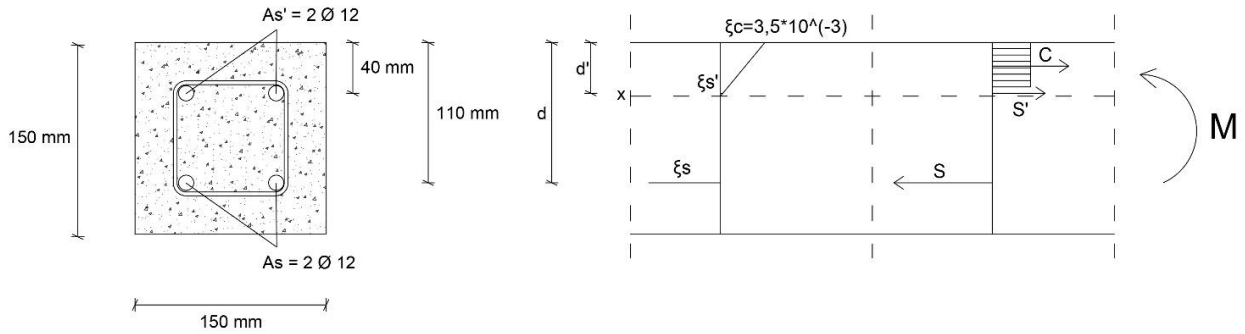

Figure 37: cross sections of the structural element

$$\begin{aligned} 1) & C + S' - S = 0 \\ 2) & C * (d - 0,4*x) + S' (d - d') = M_{RD} \end{aligned}$$

where:

$$C = 0,8*x*f_{CD}*b$$

$$S' = E_S*\epsilon_{s'}*A'_S$$

$$S = f_{yd}*A_S$$

$$f_{CD} = \text{design compression strength of concrete} = R_{ck} * \frac{\alpha_{cc}}{\gamma_c} = 25 \frac{N}{mm^2} * \frac{0,85}{1,5} = 14,11 \frac{N}{mm^2};$$

$$b = 150 \text{ mm};$$

$$E_S = 210 \text{ GPa};$$

$$\epsilon_{s'} = \epsilon_c \frac{x-d'}{x} \text{ for } \epsilon_{s'} < \epsilon_y, \text{ where } \epsilon_c = 3,5*10^{-3};$$

$$d' = 40 \text{ mm}; d = 110 \text{ mm};$$

$$A'_S = A_S = 226 \text{ mm}^2;$$

$$f_{yd} = \frac{f_k}{\gamma} = \frac{415 \frac{N}{mm^2}}{1,15} = 361 \frac{N}{mm^2};$$

The static calculations on the concrete beam have been done following the ultimate stress method, analysing the structural capacity of the cross section. It has been considered the best scenario as a failure mechanism of the element, with complete yield of the bottom steel,  $\epsilon_s = \epsilon_y$  (that has to bear tensile forces), and ultimate deformation for the compressed concrete,  $\epsilon_c$  equal to  $3,5*10^{-3}$ . It has been proceed using the method of stress-block to determine the stresses related to the compressed section of the concrete. The two fundamental equations of the equilibrium of the cross section (1) and (2) are then imposed to determine firstly the position of the neutral axis,  $x$ , and then the bending capacity of the cross section,  $M_{RD}$ .

Substituting all the factors into the fundamental equations of equilibrium it will result that:

- (1)  $x = 40 \text{ mm}$
- (2)  $M_{RD} = 8,0 \text{ kN}\cdot\text{m}$  approximately <  
 $M_{Ed,b} = 13,80 \text{ kN}\cdot\text{m}$

The values related to the resistance values of the cross section of the band, made by hands, have been checked using a software useful to calculate the dominium of resistance of the cross sections. It must be said that only the calculations related to a maximum flexion only have been made, taking their check as enough to assume valid the reliability to calculate the whole dominium of resistance with the software.

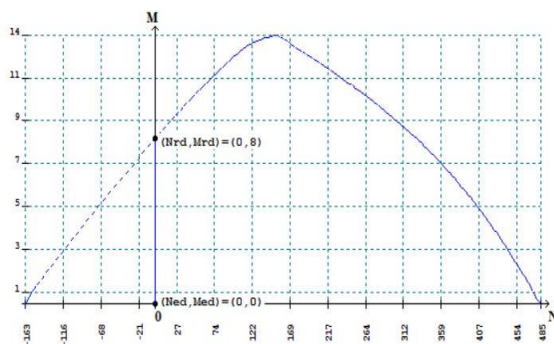

Figure 38: *Nrd, Mrd of the main beam*

### 4.3 Discussion of Results

The loads that must be applied on the house during a design stage has been derived from the current local building codes; these includes the Nepalese Building Code and the Indian Building Code. The way that loads must be combined and how to calculate them followed the indications of these two codes. When a lack of information about the way to determine, loads has been found, a few values and coefficients have been replaced using indications from the Eurocode (e.g. snow characteristic load).

The modest dimensions of the house as well as the regular shape makes the application of loads easier to be bear. Furthermore, the weight of the house itself, and especially of the roof, resulted to be relatively light. However, it has been noticed that, even if the applied loads might be seen as relatively modest, there is an unbalanced distribution of the loads thought the structures of the house. Looking at the point connections and the structural layout, the middle inner wall results to be the highest loaded, bringing by itself 2/3 of the total weight applied from the roof. The other two parallel walls are loaded by the left 1/3 of the total loads (1/6 per each one), while two out of five perimeter walls result then to be unloaded from the top.

It was not clear why a concrete skeleton has been made during the first inspections. It was thought that the purpose was to carry the loads and transmitting them directly to the foundation, and that the brick walls were made for filling the skeleton for a non-structural purpose. Static calculations about the load bearing capacity of the most loaded elements have been conducted. This step resulted in the proof that the concrete skeleton is not able to bear the load by itself. This means obviously that the load bearing function of the house is carried by the CSEB bricks, while the concrete bends serve as compartments separation between two layers of bricks. This constructive technology is growing in Eastern countries to improve the structural performance of houses in the case of earthquakes, behaving more as a unique box thanks to the reinforced concrete bends that tent to bring the elements of the house together when subjected to horizontal vibrational forces.

# 5 Roof

## 5.1 Roof calculations

### 5.1.1 Roof analysis

The roof of the model house is made out of bamboo. Statically calculations are necessary to research the behaviour of the roof under different load combinations. To make sure that the bamboo roof can hold the applied loads, it is modelled in MatrixFrame. Within the model, multiple loads are considered according snow, wind and life loads. The calculations are done with respect to critical length, bending, compression, shear and tension.

### 5.1.2 Matrix Frame

MatrixFrame is a modern software for structural calculations. The construction can be modelled into the software by adding lose elements and give them the properties of the bamboo according diameter, thickness, E-modulus, Poisson ratio and moment of inertia. The model can be found in (Figure 39). Via analysis, the maximum moment, shear force and normal force through the bamboo culms can be calculated. With these maxima, hand calculations can be done to divine if the weakest part of the structure can hold the loads.

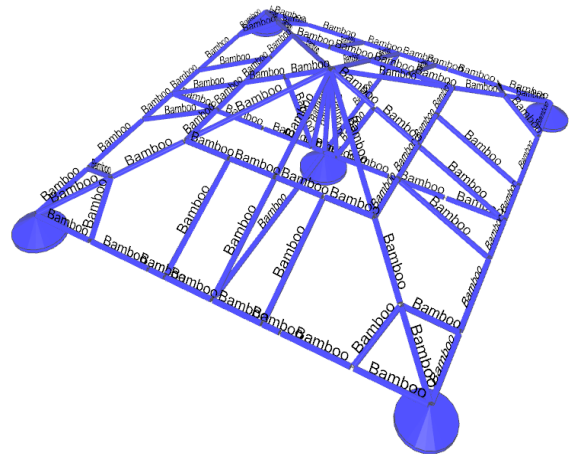

Figure 39: model of the bamboo roof in MatrixFrame

### 5.1.3 Loads and loads combination

#### Dead loads

When applying loads on the structure a few variable loads and dead loads have to be considered. First of all, the own weight of the bamboo skeleton of the roof is determined and applied to the model. The loads are determined by the volume and the density of the bamboo. Consequently, MatrixFrame will calculate these loads, using the profile properties. The loads are determined per kilo newton per meter length. Since the average cross-sectional area was determined, all of the bamboo sticks have been given an equal cross-sectional area. Resulting in the following dead load:

$$\begin{aligned}
 q_{db} &= \frac{A_{avg} \cdot \rho_{bamboo} \cdot g}{1000} = \\
 &= \frac{(0.25 \cdot \pi \cdot (65^2 - 35^2) \cdot 10^{-6}) \cdot 810 \cdot 9.81}{1000} \\
 &= 0.0187 \text{ kN/m}
 \end{aligned}$$

After determining and applying the dead load of the roof skeleton, the floor loads were added. Unfortunately, these could not be applied and constructed directly into the model since MatrixFrame only allowed a

construction of maximum one hundred sticks. The bamboo floor is however part of the dead load and has the same value as previously determined. Therefore, they have been applied as point and q-loads on the constructed model.

Another dead load which has been applied on the roof, is the own weight of the roof plates. These plates are 'CGI' plates. Firstly, the density and the area of the plates were determined and added as q-loads to the roof structure. These loads vary per meter length. A difference between the number of loads, each bamboo stick is bearing, has been made since the roof is made out of triangles. The own weight of the 'CGI' plates are calculated as per the batch they are delivered in and results as follows:

$$\begin{aligned}
 qdp &= \frac{(M/A_{batch}) \cdot g}{1000} = \\
 &= \frac{(55/(0.875 \cdot 21.9456)) \cdot 9.81}{1000} = \\
 &= 0.0281 \text{ kN/m}^2
 \end{aligned}$$

The q-load is then multiplied by the overall area of a roof side, then proportionally divided over the bamboo sticks and divided by their length.

### Snow loads

The snow loads have previously been determined and have now been applied to investigate different load combinations. The snow loads are as follows:

$$qs = 1.575 \text{ kN/m}^2$$

The variable load factor which must be multiplied with this variable load is previously

determined, following the NBC. The snow loads have been applied in the same way and with the same proportions as the loads from the roof plates, also dividing by the length of the bamboo culms.

### Live loads

The live loads have previously been determined and have now been applied to investigate different load combinations. The snow loads are as follows:

$$ql = 0.47 \text{ kN/m}^2$$

The variable load factor which must be multiplied with this variable load is previously determined, following the NBC. The live loads have been applied in the same way and with the same proportions as the loads from the roof plates, also dividing by the length of the bamboo culms.



## Bamboo properties

For the properties and profile of the bamboo, an average is considered (Table 20):

Property	Value
Diameter	0.065 [m]
Thickness	0.015 [m]
Surface	2.3562e-03 [m <sup>2</sup> ]
Shape	Tube
E-modules	1.2250e+07 [kN/m <sup>2</sup> ]
Poisson ratio	0.3 [-]
Density	810 [kg/m <sup>3</sup> ]

Table 20: bamboo properties

These properties are determined by weighing and measuring a bamboo culm used in the roof of the model house.

### 5.1.4 Maximum load bearing capacity

#### Bending

The largest moment on a column in the roof is 1.06 kink (Figure 40). This will occur when the snow loads are dominant. Calculations have been done to check if the bamboo column subjected to this moment is strong enough.

$$\sigma_{b,R} = \frac{M_y \cdot y}{I_b} = \frac{1.06 \cdot 0.0325}{8.02 \cdot 10^{-7}} = 42945.91 \text{ kN/m}^2 = 42.95 \text{ N/mm}^2$$

The ultimate bearing capacity on bending stress of the bamboo has previously been determined to be 89.32 N/mm<sup>2</sup>. This shows that the bamboo will not fail on bending.

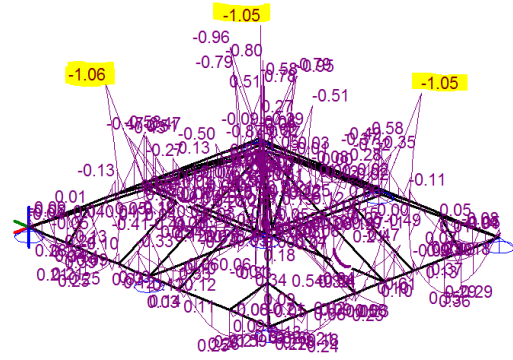

Figure 40: largest moment on a column in the roof

#### Compression

The largest compression load on a column in the roof is 22.14 kN (Figure 41). This will occur when the snow loads are dominant. Calculations have been done to check if the bamboo column subjected to this moment is strong enough.

$$\sigma_{c,R} = \frac{Nz_c}{A_b} = \frac{22.14}{2.355 \cdot 10^{-3}} = 9401.27 \text{ kN/m}^2 = 9.401 \text{ N/mm}^2$$

The ultimate bearing capacity on compressive stress of the bamboo has previously been determined to be 54.74 N/mm<sup>2</sup>. This shows that the bamboo will not fail on compression.

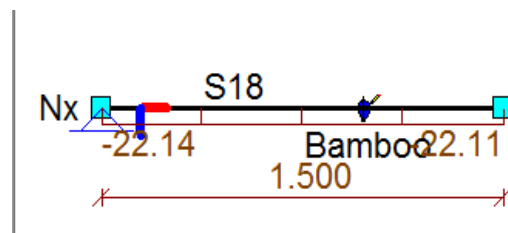

Figure 41: largest compression load on a column

## Longitudinal tension

The largest longitudinal tension load on a column in the roof is 12.33 kN (Figure 42). This will occur when the snow loads are dominant. Calculations have been done to check if the bamboo column subjected to this moment is strong enough.

$$\begin{aligned}\sigma_{tl,R} &= \frac{Nztl}{A_b} = \frac{12.33}{2.355 \cdot 10^{-3}} = \\ &= 5235.67 \text{ kN/m}^2 = 5.24 \text{ N/mm}^2\end{aligned}$$

The ultimate bearing capacity on compressive stress of the bamboo has previously been determined to be 92.84 N/mm<sup>2</sup>. This shows that the bamboo will not fail on tension.

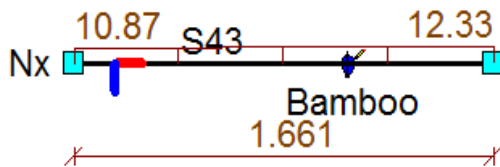

Figure 42: largest longitudinal tension load on a column

Some of the bamboo columns have been connected in the longitudinal direction in the node sections. Previously has been stated that the nodes are significantly less strong than the internode sections of the bamboo, especially when loaded in tension. Therefore, these connections have been studied on tension stresses as well. Resulting in the following calculations.

$$\begin{aligned}\sigma_{tl,R} &= \frac{Nztl}{A_b} = \frac{12.33}{2.355 \cdot 10^{-3}} \\ &= 5235.67 \text{ kN/m}^2 \\ &= 5.24 \text{ N/mm}^2\end{aligned}$$

$$\begin{aligned}\sigma_{tln,u} &= \sigma_{tln,u} \cdot 0.3 = 92.84 \cdot 0.3 \\ &= 27.85 \text{ N/mm}^2\end{aligned}$$

This value is still larger than the tensile stresses on the nodes. It can be concluded that the nodes will not fail under tensile stresses.

## Tangential tension

In some connections, the bamboo columns are loaded on tangential shear stresses, due to perpendicular shear forces applied on the bamboo columns. This may result in failure and must be checked. The shear forces applied on the bamboo column are 0.9 kN.

$$\begin{aligned}\sigma_{tt,R} &= \frac{Vztl}{A_b} = \frac{0.9}{2.355 \cdot 10^{-3}} = 382.17 \text{ kN/m}^2 \\ &= 0.382 \text{ N/mm}^2\end{aligned}$$

$$\sigma_{tt,u} = 3.47 \text{ N/mm}^2$$

The allowable stress is larger than the applied stress, which implies that the bamboo will not fail under tangential shear stress.

## Longitudinal shear

There are no connections between the bamboo columns in the roof, which are subject to longitudinal shear stresses. Therefore, no further calculations are required.

## Transversal shear

Previously to calculating and checking on transversal shear. The critical length of the bamboo beams has to be determined. As previously has been stated. When a bamboo column is subjected to bending, with a smaller span than the critical length, the column will fail under transversal shear,

instead of bending. The critical length has been determined:

$$t = 15 \text{ [mm]} \quad R = 32.5 \text{ [mm]} \quad x := \frac{t}{R} = 0.4615384615$$

$$\varepsilon = 0.00219$$

$$Er = 12250 \left[ \frac{N}{\text{mm}^2} \right]$$

$$\tau_{max} = 3.15 \text{ [N/mm}^2\text{]}$$

$$l_c = \frac{R \cdot \varepsilon \cdot Er}{\tau_{max}} \cdot \left( \frac{14x^3 - 60x^2 + 100x - 80}{20 \cdot (x-2)} \right) = 407.064 \text{ [mm]} = 0.407 \text{ [m]}$$

This critical length is shorter than any bamboo column in the roof construction. Therefore, it can be concluded that the bamboo columns will not fail under transversal shear stress.

## 5.2 Discussion of Results

The bamboo roof build by SSN on the model house in Ratankot is concluded as strong enough to bare the normal loads. The roof will not fail when the maximum bending, compression, tension and shear forces are applied on the roof. However, it is very important that the elements of the roof are connected in the right way. As stated before, specially at the connections it is the most likely that the roof will fail. The connections true the nodes are less strong than through the beams itself and therefore it is not desired to connect bamboo true the nodes. What also need to be stated is that the conclusion about the strength of the roof is checked in a non-earthquake situation. More investigation is needed to conclude that the roof is earthquake resilient. Because the analyses show that the roof is strong enough, but not act on the limits of the NBC, the roof is oversized. This means directly that also this roof is heavier than it should be. More research should be done to check which beams are to heavy or can be removed. What can be said is that the roof is lighter than a roof of stone or steel. This, in an earthquake situation, is desired because many people get killed by the weight of the roof/walls that lay on top of them. This is also the reason that the floor in the roof need to be removed. It's only meant to store goods like rice and bamboo strings, after which the roof will be heavier than needed. This is not desired at all.

# 6 Static calculations on walls

It has been demonstrated that the load bearing structural function is not carried on by the reinforced concrete elements because of the lack of structural capacity of the cross section, at least for the biggest concrete band (15 cm x 15 cm). This means that the static loads are carried by the walls made of CSEB bricks from the roof to the foundations, where they are transmitted to the basement. No indications are given by the Indian Building Code and Nepalese Building Code about the static calculations that must be made to prove the structural capacity of the load bearing elements. Then, to demonstrate the safety of the house and its structural elements during a static working situation, the load bearing capacity of the walls have been calculated and analysed following the guidelines given by the Eurocode and NTC 2008 (Technical guidelines for construction, Italy). The calculations that have been made regard the bending capacity on the two parallel and perpendicular planes among the walls and the load bearing capacity of the elements against axial distributed and punctual loads, as indicated by NTC 2008 about masonry buildings.

## 6.1 State of the house

As already mentioned in the last chapter, the house has been made of different structural elements. Particularly, a bamboo roof is applied on walls made of layers of CSEB bricks interconnected by rebar's with

reinforced concrete bands. It must be said that the role of the bands, as already demonstrated, is not to carry the loads statically, creating a concrete frame that is main load bearing structure. Instead, their application is advised by the current local building codes to improve the behaviour of the whole structure during an earthquake situation. The bands, if well realized, permit the house to behave as a collaborative box, transmitting the loads horizontally element to element instead of making the walls reacting against horizontal forces independently.

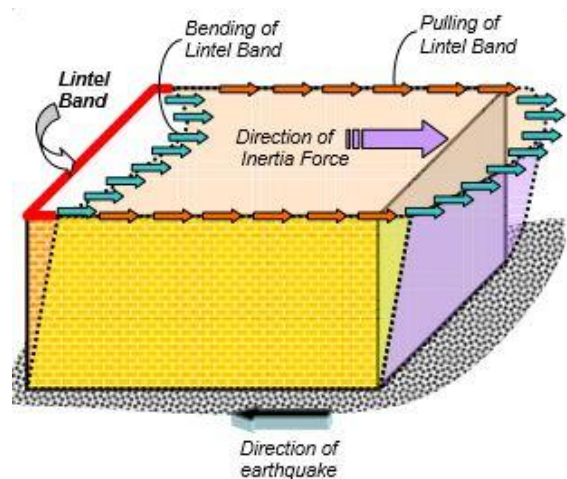

Figure 43: behaviour of masonry houses using reinforced concrete bands [C.V.R. Murty]

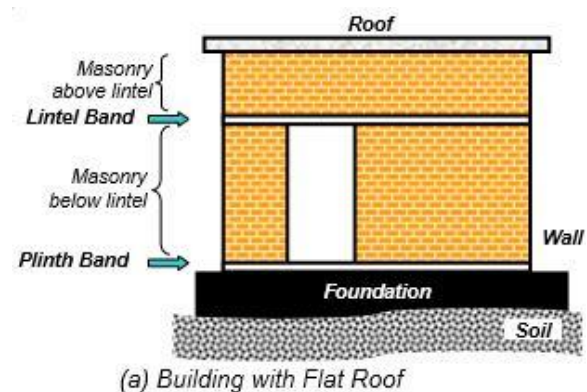

Figure 44: role of masonry houses using reinforced concrete bands [C.V.R. Murty]



In this way of construction, any vertical deflection of the concrete band will be hindered by the presence of the masonry below it, so that finally everything would be stacked on the foundation. This means that the concrete bands will not be loaded on bending until an earthquake, and then they are working either in normal force or bending out-of-plane. The static calculations have been then made only related to the CSEB brick walls, while the quasi-static calculations will then consider even the factor related to the presence of the bands, or better their load bearing capacity when horizontal earthquake forces are applied.

The presence of the three bands of the load bearing structure of the house divides horizontally the CSEB brick walls into three

different compartments with three different height. Because of their presence, assumed as rigid, it can be reasonable to assume that the three levels of the walls bear the permanent and accidental loads independently, not reacting as a unique wall, especially against wind loads that cause bending. It means that, for example, the maximum moment will happen at the middle height of each compartments instead of at the middle height of the wall intended as unique (at the height of 1,230 m). For these reasons, the static calculations regarding the structural performance of the house will be done level by level, actually considering the one-floor wall as composed by three different wall compartments to assume as continuous and reacting (Figure 45).

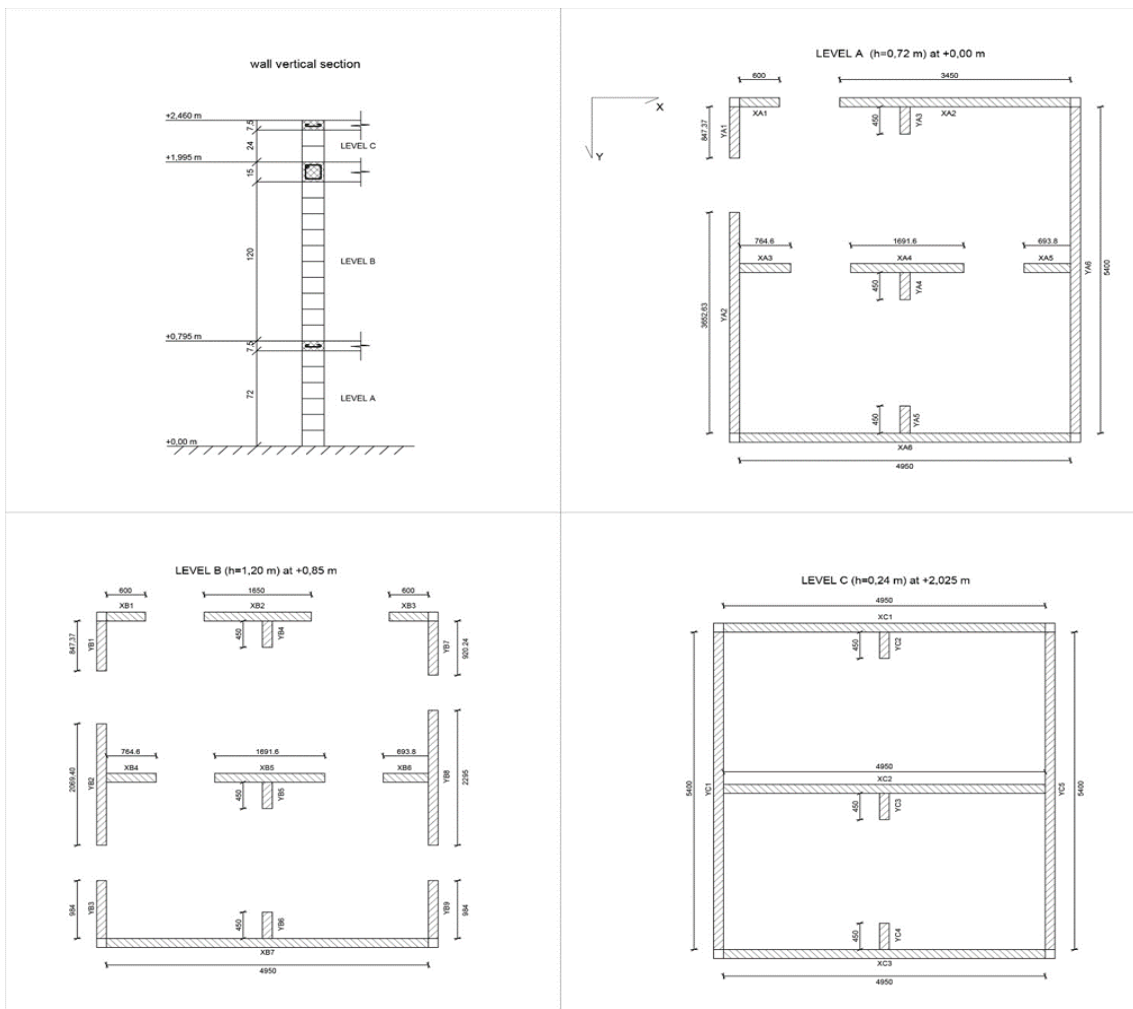

Figure 45: walls compartments subdivision and dimension divided per level. When not specified, dimensions must be considered in cm

Once again, the assumption of rigid bands, that keep rigid the levels of bricks when both horizontal and vertical loads are applied, gives the chance to reason in a static domain at least regarding the application of static loads. It is role of the bands themselves working as compartmental elements, making the applied loads more distributed among different load bearing elements (Figure 40). However, it must be said that this stays an assumption: the actual working mechanism of these elements highly depend on how

they have been made, from the quality of the material to the followed construction steps. This can give better performance in terms of slenderness (thanks to shorter buckling length of the compartments compared to the whole one) and moment resistance (registered maximum at the middle height of each compartments instead of unique at the middle of the total height), as visible comparing the schemes A and B as visible below (Figure 46).

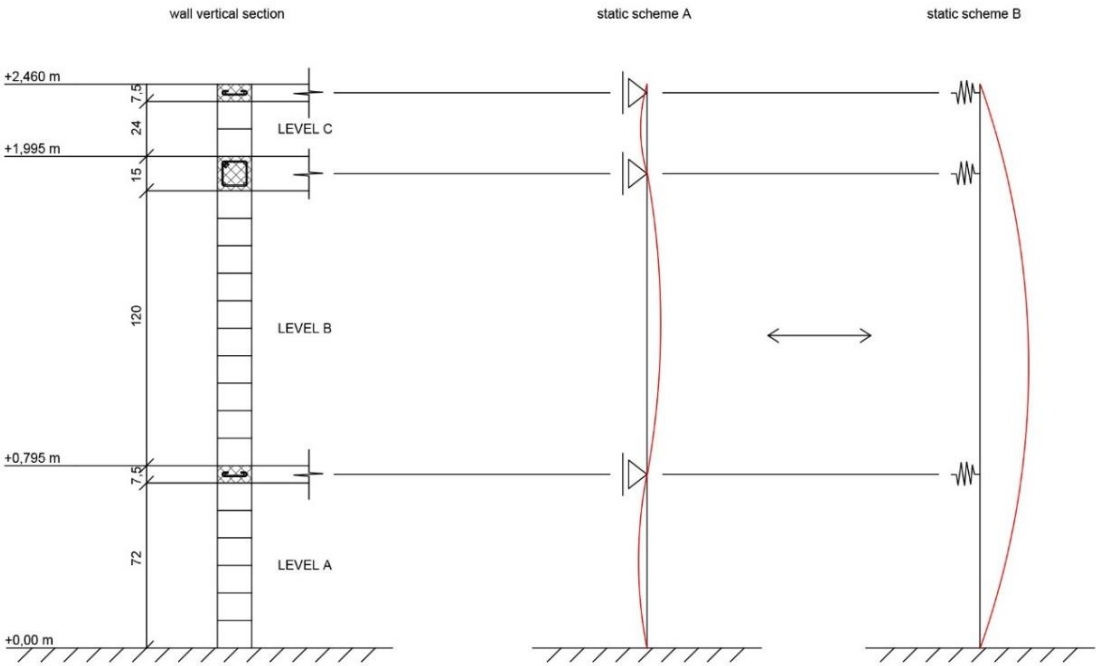

Figure 46: static structural scheme assumed bands as completely rigid element (A)

The horizontal loads are distributed between the walls depending on their *rigidity*, based on their geometry, distance from the centre of mass and their moment of inertia. It must be said that rigidity has been calculated for all the walls when earthquake horizontal forces are applied, assuming all the walls would be solicited. This does not happen in the case of wind loads application, when only the external walls in both the wind directions have been considered as reactive. Firstly, the validation of the house in Ratankot has been conducted calculating the static structural performance: more precisely, static loads have been firstly calculated and then applied on the structural elements of the house following the indications given by the Eurocode and the NTC 2008. It must be said that, in this stage, only the worst SLU combination has been considered to make calculations.

For every wall compartments, the calculations process that has been followed is mentioned above:

- Calculation of walls rigidity and wind loads distribution;
- Determination of axial and horizontal loads applied on every compartment;
- Calculations of eccentricities and coefficients of reduction of resistance;
- Compression strength against distributed loads;
- Press-flexion strength;
- Shear strength;
- Compression strength against punctual vertical loads;

## 6.2 Static calculations

### 6.2.1 Calculation of walls rigidity and wind loads distribution

As already explained in the section “loads determination” of the present report, the distributed wind load related to the area where the house has been built is equal to 1,022 KPa. Because of the “compartments approach” that has been used (the fact that walls are horizontally divided by concrete bands), it has been proceed dividing the wind loads depending directly on the plane surface of the compartments considered. Then, the total wind applied load has been distributed depending on the rigidity values of each wall compartments, as mentioned below (Figure 47).

Wind pressure,  $W_p = 1,022$  KPa

LEVEL	height [cm]	L,x [cm]	L,y [cm]	Atot,x [cmq]
A-A'	72	495	540	35640
B-B'	120	495	540	59400
C-C'	24	495	540	11880

LEVEL	Atot,y [cmq]	Fw,x [kN]	Fw,y [kN]
A-A'	38880	3,64241	3,973536
B-B'	64800	6,07068	6,62256
C-C'	12960	1,21414	1,324512

Figure 47: total wind loads applied on each wall compartment level

where:

$F_{w,x}$  and  $F_{w,y}$  are the total wind loads that will be distributed on the relative walls compartments;

*note: proceeding in favour of safety, the surfaces of the walls have been considered as without openings for the determination of the total wind load applied on the brick walls. The length along both the directions x and y of the walls are considered only for the actual length of the brick walls, without adding the dimension of the columns at the corners.*

The coefficients of distribution (named  $\alpha$ ) of the horizontal loads applied on each compartments of the same level depends on the geometric characteristics of the wall compartments themselves as mentioned below:

$$\alpha = \frac{K_{x,y,i}}{\sum K_{x,y,i}} + C_T$$

with x,y directions of the considered compartment.

$$K = \frac{1}{\frac{h^3}{\beta \cdot E \cdot I} + \frac{\kappa \cdot h}{G \cdot A}}$$

where:

h,i = height of the compartment;

$\beta$  = type of construction factor;

E = Young's modulus of the bricks;

I,i = Moment of inertia of each compartment;

$\kappa$  = shape factor (1,2 if rectangular elements);

G = Shear modulus;

A,i = horizontal surface of each compartment;

To determine  $C_T$ , the relative formula will be written regarding the walls along the x-direction for simplicity, noting that the same calculations would be valid even for those along the y-one inverting the values relative to the considered direction:

$$C_T = \frac{(K_{x,i} \cdot (y_{G,i} - Y_R) \cdot e_{y,total})}{(\sum K_{x,i} \cdot (y_{G,i} - Y_R)^2 + \sum K_{y,i} \cdot (x_{G,i} - X_R)^2)}$$

where:

$y_{G,i}$  = distance from barycentre of each compartment to the centre of mass of the level;

$$Y_R = \frac{K_{x,i} * y_{G,i}}{\sum K_{x,i}}$$

$e_{y,total}$  = total eccentricity along y-direction =  $e_y + e_{y,additional}$  where:

- $e_y = Y_C - Y_R$  (with  $Y_C$  = y-coordination of the center of mass of the whole compartment level);
- $e_{y,additional} = 0,5 * L_y$  (with  $L_y$  = length of the compartment along y-direction);

For each compartments the applied wind load will be then:

$$F_{w,x,l} = F_{w,x} * \alpha_x$$

where  $F_{w,x,y,l}$  = wind load on the plane of the wall;

It must be said that the distribution of wind loads did not consider the presence of inner walls. Indeed, for this scenario the total rigidity (and then the values of the sum of the coefficients of distribution) has been reasonably considered as only the external walls would bear the loads caused by the wind blow. Furthermore, the collaboration between walls along perpendicular direction has not been considered, making calculations on each compartment as it worked as independent from the other structural elements, proceeding in favour of safety. However, these two assumptions will not be replicated for structural calculations in the case of earthquake situations, considering even the inner walls collaborating to bear the applied loads and, consequently, changing the coefficient of distribution of applied horizontal loads.

The wind loads applied on each compartment then result as follows (Table 21):

LEVEL	CODE	$K_{x,y,i}/\sum K_{x,y,i} + C_T$	$F_{w,total,x,y}$ [kN]	
A	X	XA1	0,03200282	3,64241
	X	XA2	0,40236232	3,64241
	X	XA3	0	3,64241
	X	XA4	0	3,64241
	X	XA5	0	3,64241
	X	XA6	0,56563486	3,64241
	Y	YA1	0,050254	3,973536
	Y	YA2	0,342864	3,973536
	Y	YA3	0	3,973536
	Y	YA4	0	3,973536
	Y	YA5	0	3,973536
	Y	YA6	0,597968	3,973536
	X	XB1	0,02299637	6,07068
	X	XB2	0,19529573	6,07068
X	XB3	0,02299637	6,07068	
X	XB4	0	6,07068	
X	XB5	0	6,07068	
X	XB6	0	6,07068	
X	XB7	0,75871153	6,07068	
B	Y	YB1	0,061562	6,62256
	Y	YB2	0,321107	6,62256
	Y	YB3	0,085626	6,62256
	Y	YB4	0	6,62256
	Y	YB5	0	6,62256
	Y	YB6	0	6,62256
	Y	YB7	0,074052	6,62256
	Y	YB8	0,372026	6,62256
	Y	YB9	0,085626	6,62256

LEVEL	CODE	$K_{x,y,i}/K_{x,y,i} + C_T$	$F_{w,total,x,y}$ [kN]	
X	XC1	0,5	1,21414	
	XC2	0	1,21414	
	XC3	0,5	1,21414	
C	Y	YC1	0,48387	1,324512
	Y	YC2	0	1,324512
	Y	YC3	0	1,324512
	Y	YC4	0	1,324512
	Y	YC5	0,515964	1,324512

LEVEL	CODE	$F_{w,x,y}$ [kg]	$M_{w,b,max}$ [kg*m]
A	XA1	10,49105963	3,776781468
	XA2	131,9010957	47,48439446
	XA3	0	0
	XA4	0	0
	XA5	0	0
	XA6	185,4245646	66,75284327



YA1	17,97182731	6,469857831
YA2	122,6145517	44,1412386
YA3	0	0
YA4	0	0
YA5	0	0
YA6	213,8441117	76,98388022
XB1	12,56432405	7,538594429
XB2	106,7020118	64,0212071
XB3	12,56432405	7,538594429
XB4	0	0
XB5	0	0
XB6	0	0
XB7	414,5305401	248,718324
B		
YB1	36,692617	22,0155702
YB2	191,3895943	114,8337566
YB3	51,03567524	30,62140515
YB4	0	-1,35155E-05
YB5	0	-1,35155E-05
YB6	0	-1,35155E-05
YB7	44,13752162	26,48251297
YB8	221,7390386	133,0434232
YB9	51,03581099	30,62148659
XC1	54,63611996	6,556334395
XC2	0	0
XC3	54,63612004	6,556334405
C		
YC1	57,68022142	6,921626571
YC2	0	0
YC3	0	0
YC4	0	0
YC5	61,5060065	7,380720781

Table 21: on-plane applied horizontal forces and relative moment at the base of each compartment

$M_{w,b}$  = on-the plane moment at the base of each compartment caused by punctual wind loads  $F_{w,x,y}$  ;

Calculating the on-the-plane wind load absorbed by each wall compartment it has been assumed that the actual applied load is borne for  $\frac{1}{4}$  by the top of the vertical section,  $\frac{1}{2}$  by the middle height and the remaining  $\frac{1}{4}$  by the base of the same section. The final bending force relative to each compartment, calculated at the base as advised by NTC 2008, is:

$$M_{w,b} = \frac{1}{4} * F_w * h + \frac{1}{2} * F_w * h/2$$

where h = height of each compartment;

The contribute of the load applied at the bottom of the vertical section is then taken equal to 0 because applied at the point where the moment is calculated.

To calculate the moment due to the application of wind loads out of the plane of the walls, the kinetic pressure of the wind ( $W_p$ ) has been calculated (section "Loads determination") and used in this stage, equal to 1,022 kPa. The relative wind pressure,  $p_v$ , has been then calculated for each wall compartment as:

$$p_v \text{ [kg/m]} = 0,9 * W_p * L_i$$

with  $L_i$  = i-length of each compartment, assuming  $p_v$  equally distributed along the whole height of the wall.

Because this out-of-plane wind load must be considered as an equally distributed load, the bending stress caused by these forces ( $M_v$ ) can be easily calculated for each compartment as:

$$M_v = \frac{p_v * h, i^2}{8};$$

Finally, to calculate the eccentricities caused by the loads applied on the walls, the remaining factors that must be calculated are the axial normal forces applied on the top of each compartment as well as at the middle height and at the bottom of them. This has been done considering the load path already described previously. Only the heaviest load configuration (SLU) has been applied from the roof structure to the load bearing brick walls. For each compartment, the axial forces ( $N_i$ ) have been calculated at the top ( $N_1$ ), at the middle height ( $N_2$ ) and at the bottom ( $N_3$ ), adding the self-weight of each part of compartment while going down through the vertical section of the wall. All

the values regarding the applied loads can be seen from the Appendix files. The applied

loads relatively to each compartment for a static regime are visible below (Figure 48):

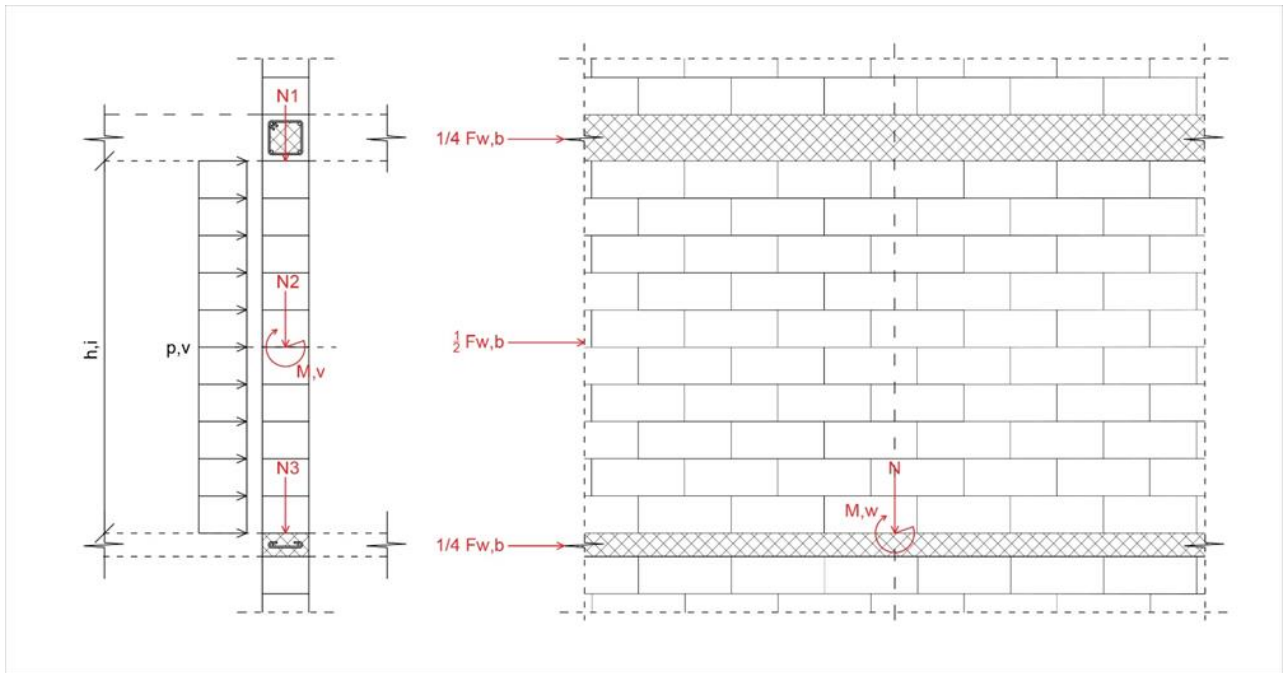

Figure 48: applied loads calculated for each wall compartment per each level

After calculating the applied loads on each wall compartments, it is possible to proceed with the determination of every eccentricities as explained by NTC 2008 and then verify the compression, bending and shear stresses for this static application of forces.

*note: the application of on-plane wind forces ( $\frac{1}{4} F_{w,b}$  at the top of the compartment and  $\frac{1}{2} F_{w,b}$  at the middle height) is equal to apply  $\frac{1}{2} F_{w,b}$  on both the top and the bottom regarding the moment caused at the bottom of each compartments, as advised by NTC 2008.*

### 6.2.2 Determination of eccentricities ( $e_i$ ) and coefficients of reduction of resistance ( $\phi_i$ )

The values of eccentricities and coefficients of reduction of resistance are necessary to develop structural verification about the on-site performance of the house. They depend on the geometry of the building and the entity of the loads themselves. The stresses must be lower than a certain resistance value of the building materials that have been used to make the house. Furthermore, to proceed in favour of safety,  $e_i$  and  $\phi_i$  must be lower than certain geometrical values that are determined directly by the normative, in this case NTC 2008. In the case these latter limits would not be respected, the house should not be taken as not safe; however, recommendations about this would be done. This does not value in the case the stresses would be higher than a certain structural capacity: in these critical cases, interventions should be done.

Below it is shown the calculation process of all the required eccentricities for the case study to proceed with structural verification:

- *accidental eccentricity*,  $e_a = \frac{h [cm]}{200}$  ;
- *eccentricity caused by out-of-plane wind pressure*,  $e_v = \frac{M_v}{N_2}$ , calculated at the middle height of each compartments, where bending stress is maximum;
- *structural eccentricities*,  $e_{s1}$  and  $e_{s2} = 0$ , assuming loads applied in the middle of the thickness of walls;
- *conventional eccentricities*:  
 $e_1 = e_{s1} + e_{s2} + e_a$  ;  $e_2 = e_v + (e_1/2)$ ;  
 where  $e_1$  will be used for making

calculations regarding the top section of each compartments, while  $e_2$  regarding the middle height section of them;

- *longitudinal eccentricity*,  $e_b = \frac{M_b}{N_3}$ , caused by the wind load applied parallel to the walls directions;
- 

The coefficients of eccentricity ( $m_i$ ), dependent on the eccentricities themselves, can be then calculated to determine later the coefficient of reduction of resistance ( $\phi_i$ ) necessary to proceed with verifications:

$$m_1 = \frac{6 * e_1}{t}; m_2 = \frac{6 * e_2}{t}; m_b = \frac{6 * e_b}{t};$$

where  $t = 150$  mm = thickness of brick walls;

The determination of the coefficients of reduction of resistance ( $\phi_i$ ) is based on probabilistic approach that gives values depending on the slenderness of the structural elements ( $\lambda$ ) and the coefficients of eccentricities ( $m_i$ ). The NTC 2008 gives then tables to get the right values depending on a specific load and geometrical situations, where the  $\phi_i$  values are taken from (Table 22).

$\lambda \backslash m$	0	0,2	0,4	0,5	0,6	0,8	1	1,2	1,4	1,5	1,6	1,8
0	1	0,9	0,79	0,74	0,71	0,65	0,59	0,53	0,47	0,44	0,42	0,37
2	0,99	0,88	0,78	0,73	0,7	0,64	0,57	0,51	0,45	0,42	0,4	0,35
4	0,98	0,87	0,77	0,72	0,68	0,62	0,56	0,49	0,43	0,4	0,38	0,33
5	0,97	0,86	0,76	0,71	0,67	0,61	0,55	0,48	0,42	0,39	0,37	0,32
6	0,95	0,84	0,74	0,69	0,66	0,59	0,53	0,46	0,4	0,37	0,34	0,29
8	0,9	0,8	0,7	0,65	0,62	0,55	0,49	0,42	0,35	0,32	0,29	0,25
10	0,86	0,76	0,66	0,61	0,58	0,51	0,45	0,38	0,31	0,27	0,25	0,2
12	0,79	0,7	0,6	0,56	0,53	0,46	0,4	0,33	0,26	0,23	0,2	0,15
14	0,72	0,64	0,55	0,51	0,47	0,41	0,35	0,28	0,22	0,19	0,16	-
15	0,69	0,61	0,52	0,48	0,45	0,38	0,32	0,26	0,2	0,17	-	-
16	0,66	0,58	0,5	0,46	0,43	0,36	0,3	0,23	0,18	-	-	-
18	0,59	0,52	0,45	0,41	0,38	0,32	0,26	0,2	-	-	-	-
20	0,53	0,46	0,39	0,36	0,33	0,28	0,23	-	-	-	-	-

Table 22: Table of coefficient of reduction of resistance ( $\phi_i$ ) depending on  $m_i$  and  $\lambda$

### 6.2.3 Structural verification

Calculating the coefficients of reduction of resistance related to the characteristics of the materials the house has been built with and knowing the loads applied on each specific wall compartment, it is then possible to check if the implied structural stresses of the working structural elements will be higher or lower than the admissible ones, where the latter depend directly on the characteristics of the used material (CSEB bricks). As already mentioned in the section "material properties analysis", the structural properties of these elements have been tested and result as:

$$f_k = \text{characteristic compression strength} = 60 \frac{kg}{cm^2}$$

$$f_{vk,0} = \text{characteristic shear strength} = 2 \frac{kg}{cm^2}$$

Proceeding in favour of safety, verifications have been conducted considering the CSEB structural properties diminished by a safety factor,  $\gamma$ , equal to 3. The design structural properties will be then:

$$f_d = \text{design compression strength} = 20 \frac{kg}{cm^2}$$

$$f_{vd} = \text{design shear strength} = 0,67 \frac{kg}{cm^2}$$

#### Compression strength

The compression stresses must be lower than the actual design compression strength,  $f_d$ , of the loaded CSEB bricks to be verified. The stresses will be checked both at the top and at the middle height of each wall compartment.

$$\sigma = \frac{N_1}{\phi_1 * A} < f_d$$

where:

$N_1$  = axial load applied on the top of the vertical section;

$\phi_1$  = coefficient of reduction of resistance;

$A$  = plan surface (horizontal) of the loaded compartment;

$$\sigma = \frac{N_2}{\phi_2 * A} < f_d$$

where:

$N_2$  = axial load applied at the middle height of the vertical section (including half of the self-weight);

$\phi_2$  = coefficient of reduction of resistance;

$A$  = plan surface (horizontal) of the loaded compartment;

#### Compression strength due to press-flexion stresses

The press-flexion normal stresses will be verified looking at the actual stress at the base of each compartment, as:

$$\sigma = \frac{N_3}{\phi_2 \phi_b * A} < f_d$$

where:

$N_3$  = axial load applied at the base of each compartment (including self-weight);

$\phi_b, \phi_2$  = coefficients of reduction of resistance;

$A$  = plan surface (horizontal) of the loaded compartment;

#### Shear stresses

The verification of the shear stresses of the compartments sections will be conducted regarding the stress related to the top section of the compartments, where the highest punctual load is applied because of the wind blowing. Three different mechanisms of failure due to shear forces will be analysed: *press-flexion failure*, *scrolling failure* and *diagonal failure*.

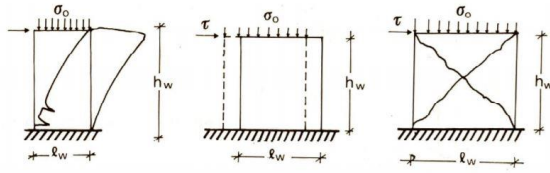

Figure 49: failure mechanisms due to shear stresses

The punctual load applied at the top of each compartment is taken as half of the total wind force,  $F_{w,i}$ , assuming that the remaining fraction of force is absorbed by the bottom section.

$$\tau = \frac{F_{w,i}}{A} < f_{vd}$$

where:

$N_3$  = fraction of punctual on-plane wind load absorbed by each compartment;

$A$  = plan surface (horizontal) of the loaded compartment;

*note: the NTC 2008 advises to consider as maximum admissible stress in the cross section the allowable shear stress  $f_{vk} = \frac{f_{vk,0} + 0,4 * \sigma_n}{3}$ , where  $\sigma_n = \frac{N_1}{A}$ , with  $N_1$  taken as the load applied in the considered section (indeed, the top on). However, still proceeding in favour of safety, the allowable stress value for each compartment has been taken as  $f_{vk} = \frac{f_{vk,0}}{3}$ . The whole calculations done to verify the structural performance of each wall compartment, as well as for the previous mentioned verification, are visible into the Appendix.*

- *press-flexion verification*

For this stress configuration, the reactive shear forces of the compartments are defined by the condition of compressed wall at the bottom base of the wall itself. It must be verified that the applied horizontal loads ( $V_{Sd} = F_{w,i}$ ) do not exceed the actual shear resistance of the compartments,  $V_{Rd}$  :

$$V_{Rd} = \frac{\sigma_0 * b^2 * t}{2 * h_0} * \left(1 - \frac{\sigma_0}{\alpha * f_d}\right) > V_{Sd}$$

where:

$\sigma_0$  = compression stress at the top of the vertical section of the wall;

$b$  = length of the compartments;

$t$  = thickness of the compartments;

$h_0$  = height of the vertical section where the moment is equal to 0;

$\alpha$  = reduction factor equal to 0,85;

$f_d$  = design compression strength;

- *scrolling failure*

In the case the compression loads applied on the walls are low, it can happen a scrolling behaviour of the compartments when horizontally loaded. In this case, the normative indicates to verify:

$$V_{Sd} < V_{Rd} = \beta * A * f_{vd}$$

where:

$A$  = transversal area of the wall =  $b * t$ ;

$f_{vd}$  = design shear strength;

$\beta$  = coefficient of partialisation of the vertical section = 1 if  $\frac{6 * e_b}{b} < 1$ ; =  $\frac{3}{2} - \frac{3 * e_b}{b}$  if  $1 < \frac{6 * e_b}{b} < 1,3$ ;

In this situation, the normative D.M. 14/01/2008 advised to assume a Coulomb behaviour of the material, described as:  $f_{vk} = f_{vk,0} + 0,4 * \sigma_0$ . However, always proceeding in favour of safety, the values of  $f_{vk}$  have been taken equal to  $f_{vk,0}$  without considering the increasing factor of compression stresses.

- *diagonal failure*

When the maximum shear stress is achieved and the loads are applied on the critic points of the section, the most reasonable failure scenario that could happen is a diagonal failure of the joints and then of the singular elements. In this limit situation, to ensure the structural performance of the building element, the normative D.M. 14/01/2008 advices to verify that:

$$V_{Sd} > V_{Rd} = b * t * \frac{f_{td}}{\varepsilon} * \sqrt{1 + \frac{\sigma_0}{f_{td}}}$$

where:

$f_{td}$  = design shear strength against diagonal stresses =  $1,5 * f_{vk,0}$ ;

$\varepsilon$  = coefficient of reduction based on the slenderness of the structural element, equal to:

- 1,0 if  $\frac{h}{b} < 1,0$ ;
- $\frac{h}{b}$  if  $1,0 < \frac{h}{b} < 1,5$
- 1,5 if  $\frac{h}{b} > 1,5$

### Punctual vertical compression loads

The verification of the stresses caused by punctual compression loads applied on the top of the CSEB brick walls has been conducted following the procedure explained inside EC6 – 6.1.3. It must be said that the application of vertical loads results linearly distributed from the roof to the walls in the current situation, confirmed even by the structural shape of the roof itself (with continuous horizontal bamboo sticks along the whole length of the lower walls). However, it could happen that in an extraordinary scenario, the loads would be applied punctually (e.g. presence of workers due to maintenance operations). To ensure

the structural safety of the load bearing structure even in this situation, the performance of the walls against punctual vertical loads from the top has been analysed (Figure 50). The verification consists on ensuring that the punctual vertical load applied on the wall,  $N_{Edc}$ , is lower than the actual maximum allowable stress of the wall itself against punctual vertical loads,  $N_{Rdc}$ :

$$N_{Edc} < N_{Rdc} = \beta * A_b * f_d$$

where:

$\beta$  = improvement factor against punctual vertical loads =

$$= \left(1 + 0,3 * \frac{a_1}{h_c}\right) * \left(1,5 - 1,1 * \frac{A_b}{A_{ef}}\right);$$

$h_c$  = height of the wall when the load is applied;

$a_1$  = distance from the point of application of the load and the edge of the wall;

$A_b$  = area of load application;

$A_{ef}$  = actual load bearing area of the wall =  $l_{efm} * t$ ;

$l_{efm}$  = actual length of the load bearing area of the wall, determined at the middle height;

$t$  = thickness of the wall;

$f_d$  = design compression strength;

*note: the EC6 imposes that:  $1,0 < \beta < \min(1,5; 1,25 + \frac{a_1}{2 * h_c})$ ;*



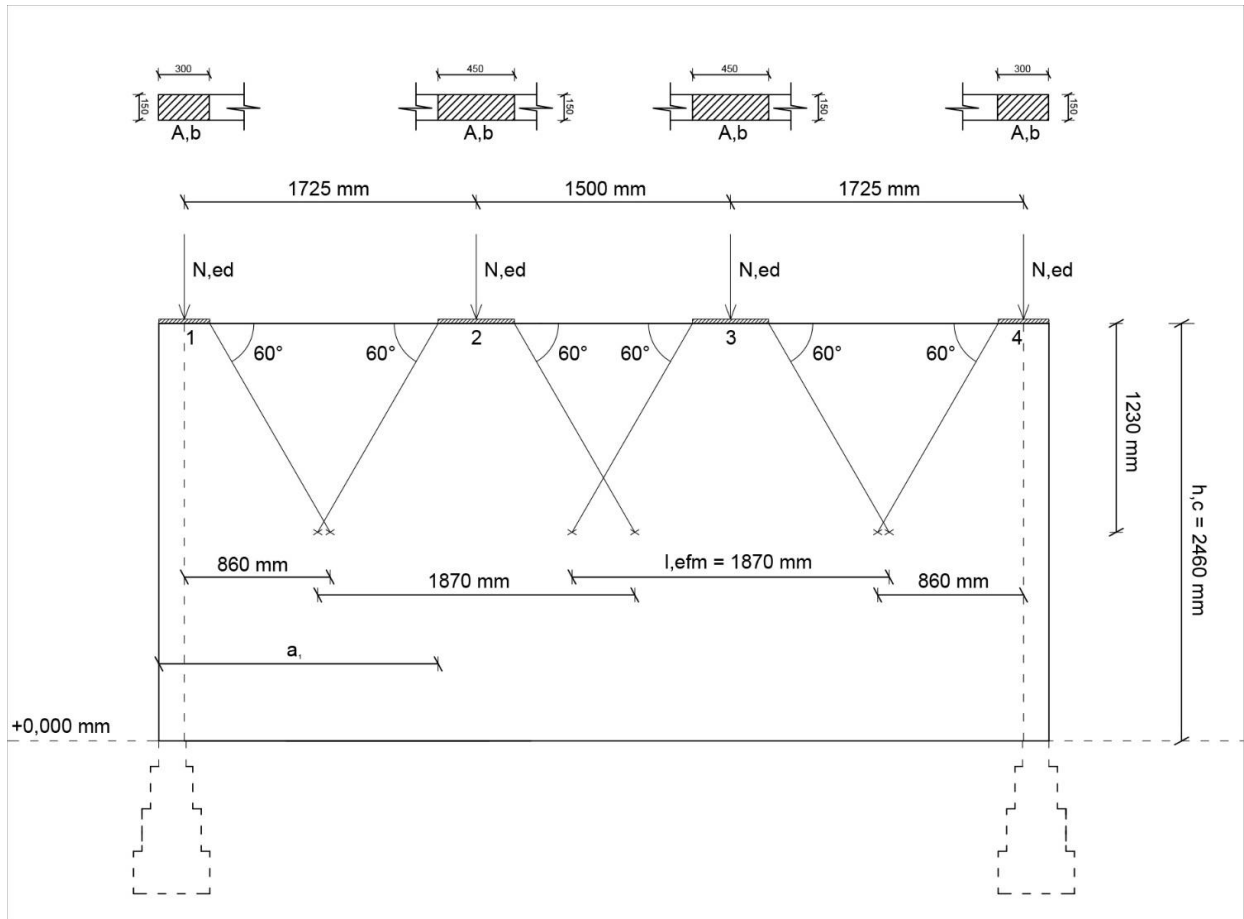

Figure 50: assumed scenario in case of punctual vertical applied loads

	$t$ [mm]	$l_{efm}$ [mm]	$a_1$ [mm]	$A_{ef}$ [mm <sup>2</sup> ]	$A_b$ [mm <sup>2</sup> ]	$\beta$	$N_{rd}$ [kg]	$N_{Ed}$ [kg]	$N_{rd} > N_{Ed}$
1	150	860	0	129000	45000	1,116279	5023,25	1288,52	verified
2	150	1870	1500	280500	67500	1,4612625	9863,52	1288,52	verified
3	150	1870	1500	280500	67500	1,4612625	9863,52	1288,52	verified
4	150	860	0	129000	45000	1,116279	5023,25	1288,52	verified

Table 23: structural performance of the 4 loads application points based on material characteristics of the walls

### 6.3 Discussion of Results

The load bearing capacity of the house built in Ratankot is given to the CSEB brick walls, a common constructive technology based on the mutual use of bricks, concrete and steel rebar's. The steel rebar's are located into holes made in the shape of the bricks, then filled with concrete. In order to verify the structural reliability of the house, static calculations have been conducted, as well as structural linear analysis as indicated by the Eurocode. Due to the uncertainty of the position of the steel rebar's and the lack of technical drawings regarding the details of the built-house, all the calculations have been conducted as if the rebar's did not be located. This way to proceed can be even seen as a further factor of safety kept during the structural verification of the state of the house.

All the calculations that have been conducted are shown into the Appendix; specifically, there will be Excel tables with all the relations already above-described theoretically. Under the application of static loads previously determined, the structure of the house offers an adequate structural performance generally. Especially regarding the structural response to the application of static vertical and horizontal loads, the stresses shown happening into the structures result to be lower than the structural capacity of the used materials, already diminished by adequate safety factors. However, there are few walls compartments that, following the Eurocode, do not match its guidelines and indications. The values of eccentricities caused by the application of axial loads and out-of-plane moment result to be much higher than what advised for many walls compartments of the second level (the higher one), and in some cases, even larger than the actual thickness of the walls. Finally, the structural

performance of the compartments is generally verified regarding their compression strength, on-plan and out-of-plan bending, the shear forces happening at the bottom of each section and the resistance against punctual loads generally.

In the structural linear analysis, the earthquake horizontal forces have been calculated and then applied on the structure of the house. In this stage, it could be seen that the structural response of the house was generally enough strong to bear them. The ultimate moment of the compartments has been shown to be always higher than the one caused by the forces application. On the other hand, for some compartments the caused shear-on-plan stresses might be too high to be bear. It must be said that the shear structural response should be given by the steel rebar's, that however have not been considered at all. If rebar's were considered, the structures would have probably fulfilled its safety requirements. Further analysis should be conducted eventually to verify this statement.

Finally, remarks must be underlined about the acceleration needed to start the mechanism of collapse of each compartment. An Excel file with different input parameters has been made available to calculate the actual collapse acceleration related to the 3 points collapse mechanism; looking at this mechanism, thanks to the modest height of the compartments, all of them have been verified as safe. However, the assumption that a 3-points collapse mechanism would happen is already a not-simple assumption. In fact, this implies that the connections between the rebar's and the concrete bands for both the bottom and top parts of each compartments will be strong enough to bear the stresses, causing the failure at the middle height of the compartment eventually. In the case this

assumption would not be valid anymore, as it might be even in this case looking at the actual quality of the construction, a 1-point collapse mechanism would happen, where the rotation point would be the bottom of the compartment. If this was the case, due to the lower acceleration of the ground needed to initiate this collapse mechanism, many compartments might not be able to bear the ground movements and the acceleration related to them.

## 6.4 Recommendations

As already mentioned, the structural capacity and performance of the house built in Ratankot mostly fulfil the requirements given by the Nepalese Building Code, the Indian Standard Code and the Eurocode. However, there are even aspects about the structural layout and capacity of the house that result to be inadequate for their structural safety purpose.

The main thing that should be improved is the distribution of the loads applied from the roof. The main connection happens to be at the top of the central inner wall, causing an overloading of that one and the respective under loading of the perimeter walls. This design choice should be modified in order to make a more redundant structure, able to carry on the loads even if one of the elements failed, which is not the case. The wrong distribution of loads, according to the Eurocode, is even visible from the too high level of eccentricities of two of the perimeter walls due to the too high moment recorded at the middle height compared to the too low axial vertical load from the top. A different distribution of the loads as well as a better understanding of the possible load paths should be analysed deeper.

The shear stresses caused by an eventual earthquake, calculated according the Eurocode guidelines, might cause shear stresses that would be bearable by the brick walls, at least for a few of them. It must be said, as already mentioned, that in this stage the presence of the rebar's has not been considered because of many uncertainties about their position have been found out. Further calculations could be conducted about the actual more reliable response of the house to earthquake horizontal forces once the presence of the rebar's would be visually inspected and checked. The presence of the walls inner rebar's has been already considered when analysing the acceleration necessary to initiate the failure mechanism of the compartments. Assuming that a 3-points failure mechanism would happen means that each wall compartment might be seen as unique body fixed and the top and bottom sides, failing at a certain quote within its own height. Further analysis and calculations and the structural reliability of these connections should be conducted as well as laboratory testing operations.

Three wall compartments have been defined by four reinforced concrete bends. It can be easily seen the different height of those first three. In order to diminish the probability of buckling, as well as to distribute the loads better through the vertical sections of each compartment, the height of the compartments should be kept as constant as possible or at least not so different between each other. Furthermore, higher compartment fail at lower ground acceleration, according to the conducted-calculations, which is not preferable in this case.

It must be said the for a static regime working situation, without any reference to earthquake forces, the happening stresses, for all of compression, shear and bending,

have been demonstrated to be lower than the actual resistance of the building materials. This means that the house can be named safe according to an ordinary application of loads. However, due to the complexity of the topic and the short time under disposition, there is no final conclusion about the structural capacity of the house in an earthquake situation. Further and more advanced calculations should be conducted in order to simulate a dynamic application of loads as much reliable as possible. However, for this purpose it might be already said the improvements should be conducted about the geometrical dimension of the structural elements, the quality of the used materials and the structural layout.

# 7 Soil properties

## 7.1 Introduction

The model pilot building in Ratankot is built on an area which belongs to the captain of the village. It is built there since no one else would offer land to SSN4 for construction. Like any other construction site, the soil parameters for this site should be investigated and determined to proceed with further calculations. Since the house is already built and little to no reconnaissance on the soil parameters have been carried out, it was deemed necessary to research this matter.

The house is built on a layered terrace-like hill, previously being farmland. To conduct further calculations, the soil must firstly be classified and its properties studied. The properties which will be investigated are the unit dry and wet weight, the angle of internal friction, the cohesion and the groundwater table. Unfortunately, little to no instruments were available on-site, which resulted in very basic tests and many assumptions regarding the properties.

## 7.2 Soil classification

Before determining the mechanical properties of the soil, it must first be classified, to gain general knowledge on its properties and nature. As stated previously the testing possibilities were limited, which resulted in onsite visual analysis and a simple penetration test.

To understand the soil classification, it is needed to state its previous nature, the

general area classification and the construction process.

The ground used for the construction area was previously used for cattle and growing crops. Since Ratankot is located on high and sloped ground, this results in a small terrace area with a mixture of different soils. The terrace like area is limited and adjacent to a higher and lower terrace.



*Figure 51: Hill houses on terrace area.*

To gain a first insight in the actual soil classification, national geo documentation was investigated and the Nepalese and Indian Building Code were consulted.

Koos Dijkshoorn and Jan Huting (2009), have constructed a Soil and Terrain (SOTER) database for Nepal. This database describes a general insight of the soil and terrain properties of Nepal (Dijkshoorn & Huting, 2009). In order to determine these general soil properties, it must be said that Ratankot is situated in the Sindupalchowk area, at c.a. 2000 m altitude. Following the SOTER database, Ratankot will then be noted as a middle mountain range area. Its dominant slope is larger than 30deg.

Proceeding with the previously stated specifications of the general terrain of Ratankot, the soil can be classified as Chromic Cambisols (CMx), containing a lithic phase as well, meaning hard rock subsoil within 50 cm of the surface (Dijkshoorn & Huting, 2009). These soil properties are confirmed by the World



Reference Base (WRB) Soil Map of Nepal and the Google Earth file given by the ISRIC World Soil Information.

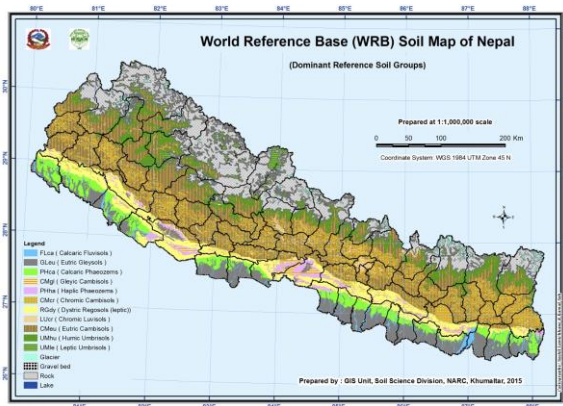

Figure 52: WRB SOIL MAP Nepal (IS.1498.1970, 2000)

Unfortunately, the classification of Chromic Cambisols do not give enough insight on the mechanical properties of the soil. Consequently, visual on-site analysis and basic penetration tests have been carried out, parallel to consulting the Nepalese and Indian Building Code.

Fortunately, two holes of about 1.5 meter were dug next to the pilot building, for other construction purposes. These gave insight into how the soil would evolve from the ground level downwards. The pictures are shown below.



Figure 53: Visual analysis soil properties

From this visual content, it could be determined that the soil contains a large amount of gravels. Even very larger sizes, containing a diameter larger than 300 mm, meaning boulders and cobbles.

Assumptions must be made regarding the expected sieve passing percentage of the soil particles. The soil contains a larger portion of large soil particles such as of cobbles, gravels and boulders; however, it also contains smaller soil particles such as sands, silts and clays. To proceed, it can be said that when performing a first sieve analysis with IS sieve 75 microns, to determine the soil classification, this soil would test as a Coarse-Grained Soil. Namely, at least 50% of the soil particles or less would pass the 75-mm sieve.

### 7.2.1 Penetration

The penetration test is done using an iron rod. It measures the penetration depth and the resistance to penetration. Unfortunately, there were no to little measuring instruments available, so a basic iron rod is used instead of a soil penetration probe. The dimensions are, 30 cm long rod with a diameter of 0.6 cm. It found that the resistance to penetration was moderate to slight and the penetration depth around three quarters of the rod. This was repeated for several spots in the soil. Furthermore, it was repeated at different depths up to 1.5 meters. It was therefore concluded that the soil is a loose soil.

It must be said that this is a very basic test, which does not indicate the real compaction, but it does indicate a little, which can lead to a slightly better founded conclusion than without.

### 7.2.2 Composition

Furthermore, the soil also contains silt, clay and sand. This is due to the fact, that Ratankot is situated near water and a river. Silt has been determined, through wetting the soil and is more dominant over the clay particles in the soil. With sand, silt and being evident in the soil, the soil can also be



classified as Loamy (IS.1498.1970, 2000). The soil contains a large amount of large and angular, cobbles, gravels and boulders; meaning it is assumed a coarse-grained soil. Furthermore, it contains silt, sand and clay, meaning it is considered a loamy soil. The simple penetration test and the visual analysis shows; it is considered a loosely packed soil. With all of the aspects of the soil given above, the soil can be classified as a GM -type soil. Meaning a silty, gravelly coarse -grained soil. The prefix (G) stands for gravel and the suffix (M) for silt.

### 7.2.3 Mechanical Properties

Now the soil is classified, the unit weights can be determined in unsaturated and saturated conditions. For both the dry and wet unit weight, mostly the book on Soil Mechanics written by Arnold Verruijt is consulted (Verruijt, 2012).

#### Dry unit weight

Besides this book, for the unit dry weight conditions, also the Nepalese and Indian building codes have been consulted (IS.1498.1970, 2000). It is stated that for the determined soil class the unit dry weight lies between 1.92 - 2.16 (g/cm<sup>3</sup>). Which results in a value of:

$$y_{dry\ range} = 1.92 - 2.16 \left( \frac{g}{cm^3} \right) = 18.83 - 21.19 \left( \frac{kN}{m^3} \right)$$

The average unit dry weight, or the unit dry weight which will be calculated with, will then be:

$$y_{dry} = \frac{18.83 + 21.19}{2} = 20.01 \approx 20 \frac{kN}{m^3}$$

#### Wet unit weight

Consequently, the wet unit weight of the soil is determined. This is done by using the specific gravity and the void ratio of the soil. It must be said, that the values for these parameters have been assumed and cannot be considered entirely accurate. The unit wet weight is calculated as follows:

$$e = e_{avg} = \frac{0.22 + 0.28}{2} = 0.25 [-]$$

$$G = \frac{(1 + e) \cdot y_{dry}}{y_w} = \frac{(1 + 0.25) \cdot 20}{10} = 2.5 [-]$$

$$y_{sat} = \frac{(G + e) \cdot y_w}{1 + e} = \frac{(2.5 + 0.25) \cdot 10}{1 + 0.25} = 22 \left[ \frac{kN}{m^3} \right]$$

With:

$y_{dry}$  = dry unit weight

$y_w$  = unit weight of water

$y_{sat}$  = saturated unit weight

$G$  = specific gravity

$e$  = void ratio

#### Internal angle of friction

The following parameter is of great importance for later calculations and determining of other parameters. The internal angle of friction is determined by consulting the Indian and European building code and the Unified Soil Classification System (Casagrande, 1952). This results in the following value for the internal angle of friction:

$$\varphi = 35^\circ \leftrightarrow \frac{7}{35} \pi \text{ rad} = 0.6109 \text{ rad}$$

## Groundwater table

The groundwater table, is like other parameters, assumed as a product of visual observations and contact with locals. As per the visual observation regarding the determining of the mechanical parameters, the groundwater table is derived from the same visual observations. A hole was dug on-site of about 1.5 meters, giving the option to observe the ground from ground level down. It was found that saturated soil occurred from about one meter below ground level.

## Cohesion and sliding resistance

At first the cohesion was assumed to be equal to zero, a drained static condition is assumed. However, the pilot house was built on a terrace like area. This means that a hill is situated right next to the house, meaning the terrace area could fail under sliding of the slope or; the slope next to the house could fail under sliding, hitting the house. See figure below a sketch of the on the hill.

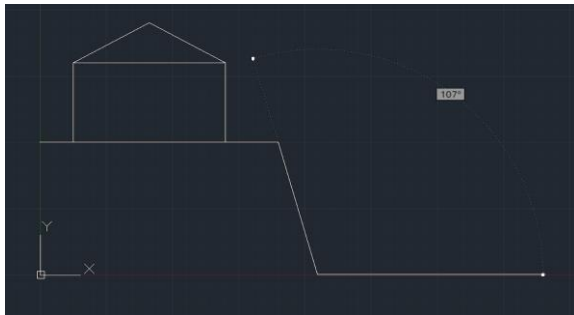

The hill next at the end of the terrace has an angle of  $107 - 90 = 17^\circ$ . This means that the internal angle of friction is larger than the hill of the area, meaning the hill is steeper. Consequently, the cohesion cannot be assumed to be zero, because the soil would slide under the determined internal angle of friction and hill angle. To calculate and determine the cohesion of the soil without the required tests and research, calculations on sliding resistance of the slope were done.

The safety against sliding according to Fellenius is considered. To assume every possibility of sliding, the situation is modelled in a computer program, GEOTechB, with the according parameters and loads. See fig. (...).

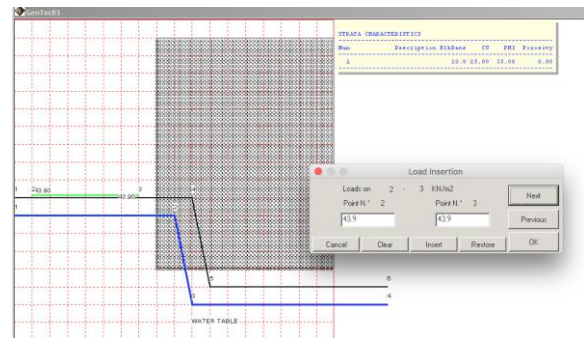

Figure 54: GeotechB program situation sliding

The conditions were assumed to be drained in this situation. It is observed that the house is already built and the hill / terrace is not failing. This means that the load, of  $43.9 \text{ kN}/\text{m}^2$ , of the house is also considered in the sliding model. Even though the maximum safety in extreme conditions is with the groundwater table at ground level, the groundwater table is here considered at one meter below ground level. Consequently, a first situation is assumed with a cohesion of zero. The model shows that the hill will fail under different sliding circles. To determine the cohesion, with respect to maximum safety, the cohesion is gradually increased to a value for which the hill will not fail under sliding.

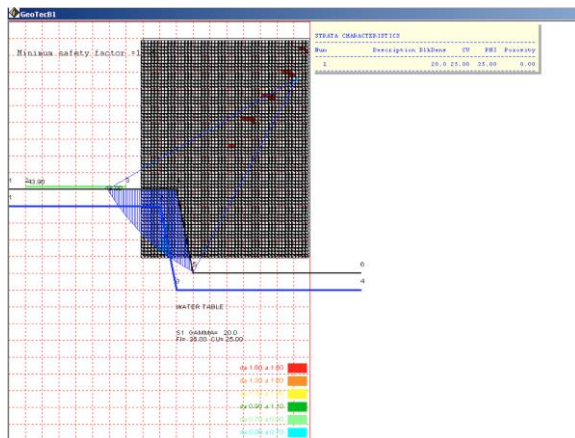

Figure 55: Final situation for no sliding cohesion is determined.

For this situation and these values, the loads and parameters, the hill is safe under the extreme drained conditions in static conditions. The cohesion then results in a value of 25 kPa. It must be said that the loads and parameters are a product of assumptions made, which could differ in the real situation, meaning further research on these soil parameters must be done.

## 7.3 Discussion of Results and Recommendations

To proceed with static and quasi-static calculations regarding the foundation of the pilot house, a few parameters and soil characteristics have been determined. Primarily the soil was classified. The soil is classified by consulting visual observations and analysis. According to the different considerations regarding the soil, a fair assumption is made regarding its classification. However, it must be noted that the classification is still an assumption and should be researched more carefully, consulting better tests, such as a plate load test or sieve analysis's. The dry unit weight of the soil is derived from the soil class. Consequently, this value must be derived after revision of the soil class through thorough testing. The saturated unit weight is a function of the dry unit weight. To determine this value and assumption for the void ratio was made. To gain a more reliable value for the saturated unit weight of the soil, it is recommended to do more tests regarding the void ratio and the different solid, air and water volumes of the soil. The internal angle of friction is, just like the unit weight, a derivation of the soil classification and therefore an assumption. After revision of the soil classification the internal angle of friction can also be revised. The source from which it is derived though, can be consulted after revision of the soil class. The groundwater table is derived from a specific situation. It is, however, safer to calculate using a ground water table it ground level, meaning the soil is fully saturated. This way no further tests should be done, which are in fact very difficult to conduct on site, and the extreme conditions are considered. For example, during monsoon time, it will likely fully saturate the area. The cohesion is determined by many different parameters, from which a few are assumed. This means that after revision and re-determining of

these parameters, such as unit weight and internal angle of friction, the cohesion should be recalculated.

Furthermore, it is recommended to do further testing on the cohesion, besides solely basing its value on calculations. To conclude, unfortunately many tools were not available, no previous research was conducted and therefore many assumptions regarding the soil parameters and classifications were made. To proceed with reliable and safe calculations, further research on the soil must be made.

# PART III. CALCULATIONS



# 8 Foundation static calculations

The soil has been classified and its parameters determined. The pilot house has already been built and is observed as statically stable. However, no calculations on the foundations have been conducted yet. In order to understand the degree of static safety, it is considered necessary to proceed with static calculations on the foundation. Furthermore, these static calculations are also necessary for further quasi-static and dynamical calculations on the foundations.

Primarily, the static loads acting on the foundations are determined. The loads acting on the foundation are the first and most important factor of determining the safety of the pilot house regarding the foundation. These are mainly the self-weight loads of the roof and walls, but also the variable loads such as snow and wind loads. After the loads, have been determined, calculations on the bearing capacity of the soil are conducted. Even though the house is visually determined to be safe and statically validated, it is wise to research what the ultimate bearing capacity of the soil is, when shear failure could occur and to what extend the soil is now safe on this failure mode. Subsequently, the resistance to horizontal sliding of the foundation will be researched. Mainly on horizontal wind loads, to understand to what extend the pilot house is safe against horizontal sliding. Lastly, the settling and deformations of the soil will be investigated and calculated under the pilot house loads.

## 8.1 Overview foundation

Predominantly, the foundation overview, characteristics and area must be defined. The foundation consists of masonry stone. It is a shallow strip foundation of approximately two feet deep. At the corners of the pilot house, below the columns, the foundation is a foot deeper and wider (SSN4, 2017).

## 8.2 Load determination

The loads are calculated regarding a total of dead loads and a total of variable loads. Consequently, these loads are multiplied by a load combination factor, derived from the Eurocode 7. Primarily, the dead loads are calculated, considering the deadweight of the roof and the corrugated galvanised iron (CGI) plates, the deadweight of the walls and the foundation strips self, acting on the soil.

### 8.2.1 Permanent load - Roof weight

The weight of the roof is both derived from the Matrix Frame model, in which the roof is modelled using average values and from rough hand calculations in the previous chapter "Loads". They both consider the weight of the corrugated iron plates and the bamboo elements. It must be said that for the bamboo elements an average value, for the material properties, such as the thickness, density and area, is chosen. This means that the eccentricities, the varieties in material properties and discontinuities per element are not considered. The value for the dead weight is therefore an indication, and can be computed in more detail. It is, however, debatable how much difference this will make in the eventual calculations. The weight and loads of the roof are defined as follows:

$$W_{roof} \approx 520 \text{ kg}$$



$$F_{roof} \approx 5.1 \text{ kN}$$

The calculations show that the weight of the roof is approximately 520 kg. This results in a total load of approximately 5.1 kN.

### 8.2.2 Permanent load - Walls weight

The total weight of the walls is calculated by calculating the weight of each wall separately, after which they are added, resulting in the total weight. This way, it can be seen what the separate weight is of each wall, for further calculations on the most heavily loaded wall. The walls consist of concrete bands, CSEB bricks, windows and doors. Consequently, the respective areas, volumes and densities are determined. Subsequently, the weight and loads are determined.

The densities of CSEB and concrete are 1800 kg/m<sup>3</sup> and 2400 kg/m<sup>3</sup> respectively. The total volumes of concrete and CSEB are then multiplied by the densities for each wall separately. The weights and loads are determined as follows:

Calculations wall:

$$W_{wall} = (\rho_{concrete} \cdot V_{concrete}) + (\rho_{CSEB} \cdot V_{CSEB}) \text{ [kg]}$$

$$F_{wall} = W_{wall} \cdot \frac{9.81}{1000} \text{ [kN]}$$

With:

$W_{wall}$  = Weight of the respective wall [kg]

$\rho_{concrete}$  = Density of the concrete [kg/m<sup>3</sup>]

$V_{concrete}$  = Volume of the respective concrete band [m<sup>3</sup>]

$\rho_{CSEB}$  = Density of a CSEB [kg/m<sup>3</sup>]

$V_{CSEB}$  = Volume of a respective CSEB wall [m<sup>3</sup>]

$F_{wall}$  = Vertical load of the respective wall [kN]

The load and weight of each wall is as follows:

Wall #	$V_{concrete}$ [m <sup>3</sup> ]	$V_{CSEB}$ [m <sup>3</sup> ]	$W_{wall}$ [kg]	$F_{wall}$ [kN]
1	0.2329	1.3824	3047.22	29.89
2	0.2295	1.5336	3311.28	32.48
3	0.2329	1.2474	2804.22	27.51
4	0.2228	1.2312	2750.76	26.98
5	0.2430	1.7486	3730.68	36.60
Total	-	-	15644.16	153.46

Table 24: Wall characteristics

### 8.2.3 Permanent load – Foundation strips weight

As previously noted, the foundation is mainly constructed of masonry stone. These stones are locally acquired from large masonry rocks. They are held together by cement, forming the foundation. To determine the weight of the foundations strips the density and unit weight of the masonry stone is determined, followed by a multiplication with the volume of each strip. It must be said that the weight of the cement is not considered, since the volume is difficult to estimate and its significance as opposed to the masonry negligible. The density and unit weight of the masonry bricks is  $2080 \text{ kg/m}^3$  and  $20.40 \text{ kN/m}^3$  respectively. The volumes are derived from the overview and cross sections (SSN4, 2017). The weights and loads are determined as follows:

Calculations weight strips:

$$W_{strip} = V_{strip} \cdot \rho_{masonry} [kg]$$

$$F_{strip} = V_{strip} \cdot \gamma_{masonry} [kN]$$

With:

$W_{strip}$  = Weight of the respective foundation strip [kg]

$\rho_{masonry}$  = Density of the masonry stone [ $\text{kg/m}^3$ ]

$V_{strip}$  = Volume of the respective foundation strip [ $\text{m}^3$ ]

$F_{strip}$  = Vertical load of the respective foundation strip [kN]

$\gamma_{masonry}$  = Unit weight masonry stone [kN]

The load and weight of each foundations strip is as follows (Table 25):

Foundation Strip #	$V_{strip} [\text{m}^3]$	$W_{strip} [kg]$	$F_{strip} [kN]$
1	1.7559	3652.27	35.82
2	1.7559	3652.27	35.82
3	1.6095	3347.76	32.83
4	1.6095	3347.76	32.83
5	1.6095	3347.76	32.83
Total	-	17347.82	170.13

Table 25: load and weight of each foundations strip

### 8.2.4 Variable loads

The variable loads have been determined in a previous chapter, "Static calculations on walls". The variable loads, which are considered, are wind, snow and life loads. To consider and calculate regarding the maximum safety, the most significant and heavy load is considered. In case of vertical loading, the snow load is the dominant and determining load.

The snow load is divided evenly over the surface of the roof. The snow load has been determined as follows:

$$S = \mu_2 \cdot S_0 = 1,05 \cdot 1,5 \text{ kN/m}^2 = 1,575 \text{ kN/m}^2$$

### 8.2.5 Total loads

The total loads and weights are determined by adding the permanent and variable loads. Moreover, these loads and weights are multiplied by a load factor. These factors consider different loading conditions and are derived and followed for different situations, following the prescription of the Eurocode 7. Five different load combinations are considered, following the Eurocode. Consequently, the largest loads are considered, with respect to safety. When the load combinations have been computed, the

total loads are determined. The total loads, considering snow loads the variable load, are determined as follows.

Furthermore, a distinction must be made between the total loads on the determining foundation strip and the total loads of the whole construction, meaning the total load on the loaded area. Primarily, the determining foundation strip load combinations are determined. After which, the total load on the entire loaded area is determined.

### Load combinations determining foundation strip

The determining foundation strip is found by adding all the loads working on the strip and compare the total loads. The most heavily loaded foundation strip is the determining strip. The model of the roof does not transmit the loads evenly over the respective walls, which results in more heavily loaded walls than other walls. Namely, one of the walls, carries 2/3 of the weight of the roof, two other walls the remaining 1/3 of the weight and the last two walls carry no loads from the roof. This does not necessarily mean that the more heavily loaded walls, determine the determining foundation strip, since the own weight of the walls differ as well. The most heavily loaded foundation strip is determined as follows (Table 26):

Foundation Strip #	Perm. Load roof	Perm. Load walls	Perm. Load strip	Total Loads
1	0	29.89	35.82	65.71
2	0	32.48	35.82	68.3
3	0.85	27.51	32.83	61.19
4	3.4	26.98	32.83	63.21
5	0.85	36.60	32.83	70.28

Table 26: Determination of the heaviest loaded foundation

This shows that, the determining foundation strip, regarding the permanent load, is strip number 5 in the cross section of the house. However, the variable loads have not yet been considered, meaning these must be added as well forming load combinations.

Two load combinations are considered, the A1 and A2 load combinations, derived from the Eurocode 7. Its respective load factors are (Table 27):

Load combination	Permanent load factor $\gamma_G$	Variable load factor $\gamma_Q$
A1	1.35	1.50
A2	1.00	1.30

Table 27: load factors

Consequently, the loads per load combination is determined, as follows:

$$F_{tot,strip} = \gamma_G \cdot G_{permanent} + \gamma_Q \cdot Q_{variable}$$

The total load per strip will then be (Table 28):

Foundation Strip #	Total Permanent Loads	Total variable loads	A1	A2
1	65.71	0	88.71	65.71
2	68.3	0	92.21	68.3
3	61.19	7.855	94.39	5
4	63.21	31.42	132.4	104.05
5	70.28	7.855	106.6	80.491
			6	5

Table 28: total load per strip

From the significant difference in variable loads between foundation strip number 4 and 5, it can be concluded that foundation strip number 4 is the determining foundation strip, for both load combination A1 as A2, seeing as it is the most heavily loaded strip. The total determining load will therefore be

132.46 kN. This load will be used when calculating the bearing capacity of the soil.

### Total load on whole loaded area

For calculations regarding other failure possibilities rather than bearing capacity failure, a different load is required, namely the total load on the entire loaded area. This load is acquired by calculation of the total weight of the pilot house acting on the soil. Subsequently it is divided by the loading area.

The total weight of the house is as follows:

$$W_{total} = W_{roof} + W_{walls} + W_{strips} =$$

$$= 520 + 15644.16 + 17347.82 = 33512 \text{ [kg]}$$

$$F_{total} = W_{total} \cdot \frac{9.81}{1000} = 33512 \cdot \frac{9.81}{1000} =$$

$$= 328.52 \text{ [kN]}$$

With:

$W_{total}$  = Weight of the pilot house [kg]

$W_{roof}$  = Weight of the roof of the pilot house [kg]

$W_{walls}$  = Weight of the sum of the walls of the pilot house [kg]

$W_{strips}$  = Weight of the sum of the foundations strips of the pilot house [kg]

$F_{total}$  = Total vertical load of the pilot house [kN]

Furthermore, the variable loads must be considered as well and the load combinations, regarding the permanent and variable loads. These load combinations are discussed in subsequent chapters, seeing as the variable loads differ per failure mechanism or situation.

## 8.3 Static calculations

### 8.3.1 Bearing capacity

To directly narrow the calculations down, and avoid making redundant and too many calculations, the most heavily loaded foundation strip is considered. This is in favour of safety, since it can be said that in case the most heavily loaded wall and strip can bear the loads, the other walls and strips will also hold, since they are less heavily loaded.

When calculating the bearing capacity of the soil, the previously calculated load on the determining strip is expressed as a q-load. After which, the material properties are determined and the material factors are determined as per different load combinations. Subsequently, the bearing capacity factors are determined as per different load combinations. Furthermore, the overburden and groundwater table influence are determined.

### Q load determining on soil

Previously it has been determined that the maximum load on a single strip is 132.46 kN. However, to determine the bearing capacity, it is required to attain the maximum q-load on the soil. The vertical q-load will therefore be:

$$q_{v,max} = \frac{F_{v,max}}{A_{strip}} = \frac{F_{v,max}}{B_{strip} \cdot L_{strip}} \text{ kN/m}^2$$

For the load combination, A1:

$$q_{v,max} = \frac{F_{v,max}}{A_{strip}} = \frac{F_{v,max}}{B_{strip} \cdot L_{strip}} = \frac{132.46}{(2 \cdot 0.3048) \cdot 4.95} =$$

$$= \frac{132.46}{3.017520} = 43.93 \text{ kN/m}^2$$

For the load combination A2:

$$q_{v,max} = \frac{F_{v,max}}{A_{strip}} = \frac{F_{v,max}}{B_{strip} \cdot L_{strip}} = \frac{104.056}{(2 \cdot 0.3048) \cdot 4.95} = \frac{104.056}{3.017520} = 34.49 \text{ kN/m}^2$$

with:

$q_{v,max}$  = Maximum q-load on the foundation strip [ $kN/m^2$ ]

$F_{v,max}$  = Maximum point load on the foundation strip [ $kN$ ]

$A_{strip}$  = Area foundation strip [ $m^2$ ]

$B_{strip}$  = Width of foundation strip [ $m$ ]

$L_{strip}$  = Length of foundation strip [ $m$ ]

### 8.3.2 Material factor

#### Load combination factor

When considering the full load combination, resulting in the final bearing capacity, the material properties must also be multiplied by a load combination factor, the material property factors (EN.1997-1, 2004). Regarding the bearing capacity, these are only determined for the cohesion and the internal angle of friction (Table 29), as follows:

Load combination	Internal angle of friction L.C. factor $\gamma_\phi$	Cohesion factor $\gamma_c$	L.C.
M1	1.00	1.00	
M2	1.25	1.25	

Table 29: internal angle of friction

Consequently, the values for the internal angle of friction become:

$$\varphi_{M1} = \frac{\varphi}{\gamma_{\phi,M1}} = \frac{35^\circ}{1} = 35^\circ \leftrightarrow 0.611 \text{ rad}$$

$$\varphi_{M2} = \frac{\varphi}{\gamma_{\phi,M2}} = \frac{35^\circ}{1.25} = 28^\circ \leftrightarrow 0.511 \text{ rad}$$

And the values for the cohesion become:

$$c_{M1} = \frac{c}{\gamma_{c,M1}} = \frac{25}{1} = 25 \text{ kPa}$$

$$c_{M2} = \frac{c}{\gamma_{c,M2}} = \frac{25}{1.25} = 20 \text{ kPa}$$

#### Bearing capacity factor

Now that the material parameters have been multiplied by that load factors; and since the bearing capacity factors are a function of the material factors, the bearing capacity factors can be found with respect to the load combinations. After which the shape factors can be found the same way. Firstly, the bearing capacity factors are determined, using the principle of Brinch Hansen (Verruijt, 2012), as follows:

$$N_q = \frac{1 + \sin \varphi_M}{1 - \sin \varphi_M} \cdot \exp(\pi \cdot \tan \varphi_M)$$

$$N_c = (N_q - 1) \cdot \cot \varphi_M$$

$$N_\gamma = 2(N_q - 1) \cdot \tan \varphi_M$$

The values (Table 30) are as follows, for both load combinations:

Bearing capacity factor	M1	M2
$N_q$	33.26	16.91
$N_c$	46.07	28.40
$N_\gamma$	45.18	17.82

Table 30: Bearing capacity factors

#### Shape factor

Subsequently, the shape factors (Table 31) are determined, following the same principle as for the bearing capacity factors (Verruijt,

2012). The factors are determined as follows, again with respect to the load combinations:

$$s_q = 1 + \left(\frac{B}{L}\right) \cdot \sin\varphi_M$$

$$s_c = 1 + \left(0.2 \cdot \frac{B}{L}\right)$$

$$s_\gamma = 1 + \left(0.2 \cdot \frac{B}{L}\right)$$

The values are as follows, for bot load combinations:

Bearing capacity factor	M1	M2
$s_q$	1.071	1.060
$s_c$	1.025	1.025
$s_\gamma$	0.963	0.963

Table 31: shape factors

### 8.3.3 Overburden strip

Since, the situation contains an overburden on the strip, the according q-load regarding this overburden must be calculated. The overburden is a load induced on the strip by the ground above the foundation strip, and shall therefore be calculated using the unit weight of the soil. The dry unit weight shall be used, because the saturated soil only starts below the foundation. The overburden is calculated as follows.

$$d_{over} = 1 \text{ ft} = 0.3048 \text{ m}$$

$$q = 0.5 \cdot \gamma_{eff} \cdot d_{over} =$$

$$= 0.5 \cdot (\gamma_{dry} - \gamma_w) \cdot d_{over} =$$

$$= 0.5 \cdot 10 \cdot 0.3048 = 1.52400 \text{ kN/m}^2$$

$$d_{over} = \text{Depth overburden [m]}$$

$$\gamma_{eff} = \text{Effective unit weight soil [kN/m}^3]$$

$$\gamma_{dry} = \text{Dry unit weight soil [kN/m}^3]$$

$$\gamma_w = \text{Unit weight water [kN/m}^3]$$

$$q = \text{Total vertical overburden load [kN/m}^2]$$

### Load combination factors and load combinations

As previously noted, different load combinations are considered, when calculating the bearing capacity following the Eurocode (EN.1997-1, 2004). The following combinations are considered, calculating the bearing capacity:

$$DA11 = A1 + M1 + R1$$

$$DA12 = A2 + M2 + R2$$

$$DA2 = A1 + M1 + R2$$

$$DA3 = (A1 \text{ or } A2) + M2 + R3$$

Where the R factors are load combinations factor (EN.1997-1, 2004):

$$R1 = 1.0$$

$$R2 = 1.4$$

$$R3 = 1.0$$



## Bearing load

Ultimately the bearing capacity is calculated using the formula of Brinch Hansen, also containing the shape factors (Verruijt, 2012). The unknown bearing capacity load is written as follows:

$$p = s_c c N_c + s_q q N_q + s_\gamma \frac{1}{2} \gamma B N_\gamma$$

With:

$p$  = Bearing capacity load [ $kN/m^2$ ]

$s_c, s_q, s_\gamma$  = Respective shape factors [–]

$c$  = Cohesion soil [ $kPa$ ]

$N_c, N_q, N_\gamma$  = Respective bearing capacity coefficients [–]

$q$  = Overburden  $q$ -load on the foundation strip [ $kN/m^2$ ]

$\gamma$  = Volumetric weight soil [ $kN/m^3$ ]

$B$  = Width foundation strip [ $m$ ]

Furthermore, the load combinations must be considered, using this formula, as well. Therefore, the shape factors, bearing capacity coefficients and cohesion values must be considered according to these load combinations, as previously described. The final bearing load must be divided by the according load combinations factor (R), as previously described. This results in five different load combinations.

Moreover, the actual load induced on the strip foundation is already determined. Therefore, when having calculated the bearing load, a unity check can be done, to consider the safety of the bearing capacity.

The results are as follows (Table 32):

Load comb.	L.C. specs	Bearing load $p$ [ $kN/m^2$ ]	Applied load $q$ [ $kN/m^2$ ]	Unity Check U.C.
1	A1+M1+R1	1879.49	43.93	0.0233
2	A2+M2+R2	646.44	34.49	0.0533
3	A1+M1+R2	1342.49	43.93	0.0327
4A	A1+M2+R3	905.02	43.93	0.0485
4B	A2+M2+R3	905.02	34.49	0.0381

Table 32: safety of the bearing capacity

It can be seen from the unity checks that the bearing load is larger than the induced loads by the pilot house in Ratankot. It can therefore be said that the foundation is safe regarding the bearing capacity of the soil.

## 8.3.4 Groundwater table

The groundwater table must not be forgotten when calculating the bearing capacity, since it differs with a difference in groundwater table location. The ground water table influence calculation considering the bearing capacity is different for two situations.

Firstly, for when the groundwater table is closer to ground level than the foundation depth and secondly for when the groundwater table is lower than the actual foundation level. A unique situation can also be considered where the groundwater table is the same level as the foundation depth. Since, the situation at Ratankot considers the second option, the calculations are followed using this principle (Prasad, 2013). The influence is calculated as follows:

$$Z_w = 1 - d_f = 1 - (2 \cdot 0.3048) = 0.3904 \text{ m}$$

$$R_{w1} = 0.5 \cdot \left(1 + \frac{Z_w}{B}\right) = 0.82 \text{ m}$$

$$R_{w1} = 1.00 \text{ m}$$

$Z_w$  = the depth of water table from ground level [ $m$ ]

$d_f$  = Depth foundation strip [ $m$ ]

$B$  = Width foundation strip [ $m$ ]

$R_{w1}$  = Water table coefficient [-]

$R_{w2}$  = Water table coefficient [-]

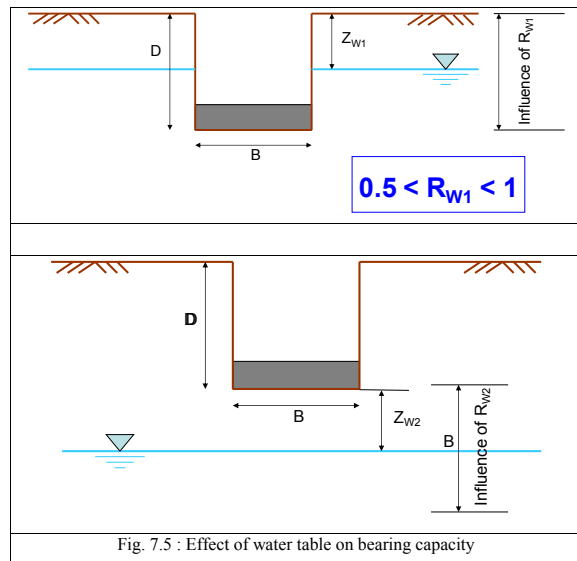

Figure 56: Effect of water table on bearing capacity (Prasad, 2013).

The results of the bearing load, previously determined, are formed without considering the ground water table influence. When considering the ground water table influence, the Brinch Hansen formula is altered as follows:

$$p = s_c c N_c + s_q q N_q R_{w1} + s_\gamma \frac{1}{2} \gamma B N_\gamma R_{w2}$$

This results in the following values for the bearing load and the unity checks, considering the load combinations:

Table 33: values for the bearing load and the unity checks

The unity checks show that for the bearing capacity of the soil the foundation can still be considered safe. The change in bearing load, shows that the groundwater table influence just has a slight impact.

### 8.3.5 Horizontal sliding resistance

The static calculations on sliding resistance will only consider resistance to one

horizontal force, the wind load. It may be considered a redundant calculation, since it can be argued that the foundation will not fail under sliding as a function of the wind load, since this load will be considered too small with respect to the load of the house. The calculations will be done none the less, to determine to what extent the house is safe to horizontal loads. This is mainly done to understand and predict the impact of further possible quasi static horizontal earthquake loads.

Primarily the load combinations will be determined, as per the Eurocode 7. After which, the induced load, as a function of the wind load. Subsequently, the according material parameters will be determined. Finally, the sliding load will be determined and the unity checks will be conducted.

### Load combination factor and load combination

As previously noted, different load combinations are considered, when calculating the bearing capacity following the (EN.1997-1, 2004). However, when considered the sliding resistance different load combinations must be considered. The following combinations are considered, calculating the bearing capacity:

$$DA11 = A1 + M1 + R1$$

$$DA12 = A2 + M2 + R2$$

Load combination	L.C. specs	Bearing load p [kN/m <sup>2</sup> ]	Applied load q [kN/m <sup>2</sup> ]	Unity Check U.C.
1	A1+M1+R1	1801.43	43.93	0.0243
2	A2+M2+R2	618.38	34.49	0.0558
3	A1+M1+R2	1286.74	43.93	0.0341
4A	A1+M2+R3	865.73	43.93	0.0507
4B	A2+M2+R3	865.73	34.49	0.0398

$$DA2 = A1 + M1 + R2$$

$$DA3 = (A1 \text{ or } A2) + M2 + R3$$

Where the R factors are load combinations factor (EN.1997-1, 2004):

$$R1 = 1.0$$

$$R2 = 1.1$$

$$R3 = 1.0$$

### Induced wind load

The wind load has previously been determined, with a maximum load on a single wall is:

$$\begin{aligned} F_{H,wind} &= q_{H,wind} \cdot A_{wall} = \\ &= q_{H,wind} \cdot H_{wall} \cdot L_{wall} \text{ [kN]} \end{aligned}$$

It must be said that this point load is applied in the middle of the wall. For simplicity reasons, the load is shifted down towards the middle of the foundation strip, this way neglecting the moment on the foundation as a function of the shifted wind load.

The wind load is considered a variable load, meaning permanent loads are absent in this load combination, considering variable load combination factors.

Two load combinations are considered, the A1 and A2 load combinations, derived from the Eurocode 7. Its respective load factors are (Table 34):

Load combination	Variable load factor $\gamma_Q$
A1	1.50
A2	1.30

Table 34: respective load factors

Resulting in the following values:

For the load combination, A1:

$$\begin{aligned} F_{H,wind} &= \gamma_Q \cdot q_{H,wind} \cdot A_{wall} = \gamma_Q \cdot q_{H,wind} \cdot \\ &H_{wall} \cdot L_{wall} = 1.5 \cdot 1.002 \cdot 2.46 \cdot 5.7 = \\ &21.075 \text{ kN} \end{aligned}$$

For the load combination, A2:

$$\begin{aligned} F_{H,wind} &= \gamma_Q \cdot q_{H,wind} \cdot A_{wall} = \gamma_Q \cdot q_{H,wind} \cdot \\ &H_{wall} \cdot L_{wall} = 1.3 \cdot 1.002 \cdot 2.46 \cdot 5.7 = \\ &18.265 \text{ kN} \end{aligned}$$

With:

$q_{H,wind}$  = Wind load on the foundation [kN/m<sup>2</sup>]

$F_{H,wind}$  = Wind point load on the foundation [kN]

$A_{wall}$  = Area foundation strip [m<sup>2</sup>]

$H_{wall}$  = Height of wall [m]

$L_{wall}$  = Length of wall [m]

$\gamma_Q$  = Load combination factor variable loads [-]

The sliding resistance is a function of the material properties of the soil and the foundation and the weight of the house. Firstly, the relevant material properties are considered.

### Material factor

As opposed to the internal angle of friction for the bearing capacity, for the sliding resistance a different friction angle must be considered. The friction angle between the masonry blocks filled with cement mortar and the soil, gravelly and silty with a fair number of boulders and cobbles. The so-called surface angle of friction is however a function of the internal angle of friction and is described as follows:

$$\delta = 0.7 \cdot \varphi = 0.7 \cdot 35^\circ = 24.5^\circ$$

When considering the material factors, by following the load combinations, the following values for the surface angle of friction must be considered (Table 35):

Load combination	Permanent load factor $\gamma_s$
M1	1.00
M2	1.25

Table 35: values for the surface angle of friction

Consequently, the values for the surface angle of friction become:

$$\delta_{M1} = \frac{\delta}{\gamma_{\delta, M1}} = \frac{24.5^\circ}{1} = 24.5^\circ \leftrightarrow 0.427 \text{ rad}$$

$$\delta_{M2} = \frac{\delta}{\gamma_{\delta, M2}} = \frac{24.5^\circ}{1.25} = 19.6^\circ \leftrightarrow 0.342 \text{ rad}$$

The induce loads on the strips have been previously determined even considering the load combinations. However, in favour of safety, no vertical variable loads are considered. The loads on the strips will then be as follows (Table 36):

Foundation Strip #	Total Permanent Loads	A1	A2
1	65.71	88.71	65.71
2	68.3	92.21	68.30
3	61.19	82.61	61.19
4	63.21	85.33	63.21
5	70.28	94.88	70.28

Table 36: the loads on the strips

Consequently, the most loaded strip, is foundation strip number 5. The induced value on the strip is 94.88 kN.

## Sliding resistance

The sliding resistance is determined by the combination of the surface angle of friction and the induced weight on the foundation strip. Both contribute to the sliding resistance. However, the sliding is initiated by a horizontal load. The vertical resistance must therefore be translated into a horizontal sliding resistance, as follows:

$$R_d = V_{sliding} \cdot \tan(\delta)$$

Furthermore, the load combinations must be considered. The final sliding resistance must be divided by the according load combinations factor (R), as previously described. This results in five different load combinations. Moreover, the imposed wind load is known and the resistance calculated. After which, the unity checks (Table 37) will be conducted to check the safety to sliding.

Load comb.	L.C. specs	Sliding resistance Rd [kN]	Applied load Hd [kN]	Unity Check U.C.
1	A1+M1+R1	...	21.075	...
2	A2+M2+R2	...	18.265	...
3	A1+M1+R2	...	21.075	...
4	A1+M2+R3	...	21.075	...
5	A2+M2+R3	...	18.265	...

Table 37: unity checks

It can be seen from the unity checks that the sliding resistance is larger than the induced loads by the wind on the pilot house. It can therefore be said that the foundation is safe regarding the sliding.

## 8.4 Settling and deformations

The structure, being the pilot house, transmits the forces and loads to the foundation, which in turn almost evenly spreads these loads and stresses over the soil. "Part of the soil structure interaction requirement is then the condition that the stress must not give rise to a deformation of the soil in excess of what the superstructure can tolerate (Fellenius, 2006). The resulting deformations and safety to failure must be researched, when designing the foundation, by researching the distribution of effective stresses, the soil strength and imposed effective stresses. Primarily, the full load of the house must be determined, imposed on its footprint over the soil. After which, the deformations can be determined.

### 8.4.1 Load of the house

The full load of the house is acquired by considering the full weight of the roof, the corrugated iron plates, the weight of the individual walls and the weight of the foundation strips. Furthermore, the variable loads must be considered. Previously these weights and loads have been determined.

### Roof

Previous calculations show that the total weight of the roof, including corrugated iron plates, is approximately 520 kg. This results in a total load of approximately 5.1 kN.

### Walls

The load and weight of each wall (Table 38) is as follows:

Wall #	$V_{concrete}$ [m <sup>3</sup> ]	$V_{CSEB}$ [m <sup>3</sup> ]	$W_{wall}$ [kg]	$F_{wall}$ [kN]
1	0.2329	1.3824	3047.22	29.89
2	0.2295	1.5336	3311.28	32.48
3	0.2329	1.2474	2804.22	27.51
4	0.2228	1.2312	2750.76	26.98
5	0.2430	1.7486	3730.68	36.60
Total	-	-	15644.16	153.46

Table 38: load and weight of each wall

### Foundation strips

The load and weight of each foundation strip is as follows:

Foundation Strip #	$V_{strip}$ [m <sup>3</sup> ]	$W_{strip}$ [kg]	$F_{strip}$ [kN]
1	1.7559	3652.27	35.82
2	1.7559	3652.27	35.82
3	1.6095	3347.76	32.83
4	1.6095	3347.76	32.83
5	1.6095	3347.76	32.83
Total	-	17347.82	170.13

Table 39: load and weight of each foundation strip

### Total load

Strip #	Perm. Load roof [kN]	Perm. Load walls [kN]	Perm. Load strip[kN]	Total Loads
1	0	29.89	35.82	65.71
2	0	32.48	35.82	68.3
3	0.85	27.51	32.83	61.19
4	3.4	26.98	32.83	63.21
5	0.85	36.60	32.83	70.28
Total	5.1	153.46	170.13	328.69

Table 40: total load

In the appendix, it is shown that the total permanent load is 328.69 kN. However, the variable loads have not yet been considered, meaning these must be added as well forming load combinations. A variable snow load is considered of:

$$F_{snow} = q_{snow} \cdot A_{roof} = 1.575 \cdot 29.925 = 47.13 \text{ kN}$$

Two load combinations are considered, the A1 and A2 load combinations, derived from the Eurocode. Its respective load factors are:

Consequently, the loads per load combination is determined, as follows:

$$F_{tot} = \gamma_G \cdot G_{permanent} + \gamma_Q \cdot Q_{variable}$$

$$q_{tot} = \frac{F_{tot}}{A_{tot}}$$

With  $A_{tot} = 16.55 \text{ m}^2$

The total load for load combination A1 will be:

$$F_{tot} = \gamma_G \cdot G_{permanent} + \gamma_Q \cdot Q_{variable} = 1.35 \cdot 328.69 + 1.5 \cdot 47.13 = 514.43 \text{ kN}$$

$$q_{tot} = \frac{F_{tot}}{A_{tot}} = \frac{514.43}{16.55} = 31.08 \text{ kN/m}^2$$

The total load for load combination A2 will be:

$$F_{tot} = \gamma_G \cdot G_{permanent} + \gamma_Q \cdot Q_{variable} = 1.35 \cdot 328.69 + 1.5 \cdot 47.13 = 389.96 \text{ kN}$$

$$q_{tot} = \frac{F_{tot}}{A_{tot}} = \frac{389.96}{16.55} = 23.56 \text{ kN/m}^2$$

## 8.4.2 Deformations

When considering deformations in the soil, a distinction must be made between immediate settlement and consolidation. The first being a short-term settlement and the latter being a long-term settlement. Favourably a penetration should be done to determine the soil development and soil layers. This way knowing the different parameters with respect to settlement calculations. Unfortunately, these penetration test could not be done on-site. Therefore, a basic immediate settlement calculation can be made, making a few assumptions. These will be done primarily following the Eurocode. However, even estimating settlement calculations require data, which in this case is not available. Therefore, a second possibility is research to predict the average settlement of the soil, with a normalised Load-Displacement behaviour analysis. This is in fact a universal approach to the load-settlement behaviour of shallow foundations on granular soils.

### 8.4.3 First settlement calculations: estimate height compressible layer

A first estimation of the immediate settlement of the soil is conducted. Primarily, the height of the compressible soil layer is unknown. Furthermore, the different soil layers, from ground level to the incompressible layer is unknown. These are two very crucial parameters and unknowns regarding the calculation of the immediate settlement. However, an estimation regarding the height of the compressible layer can be made, considering a rule of thumb and a hypothetical scenario.

The different layers and layer height of the whole compressible layer cannot be



estimated and must be determined using soil research. The whole compressible layer is therefore considered a homogenous layer, of in this case a gravelly – silty (GM) soil.

After estimation of the height of the compressible layer the Eurocode 7, will be followed, regarding the serviceability check of the foundation. Consequently a calculation of immediate (mean) settlement is made, through usage of the linear elastic solution, which takes the sum of the contributions to total settlement from each j-stratum with constant elastic parameters ( $E_j, \nu_j$ ) (EN.1997-1, 2004). However, this case only takes one j-stratum, since the layer is considered homogenous.

Primarily the height of the compressible layer (Figure 57) is determined. An estimation of this height can be made as a function of the width of the foundation. The height of the compressible layer will be the value of five times the width of the foundation (Ozer, 2012). In the case of Ratankot the height will be as follows:

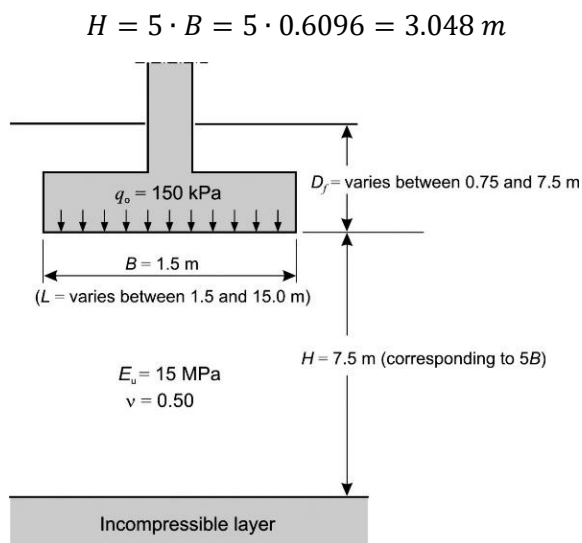

Figure 57: height of the compressible layer (Ozer, 2012).

The constant elastic parameter must be determined as well, being the Elastic

modulus of the soil and the Poisson's ratio of the soil.

As previously stated the soil which is considered is a medium - loose gravelly – silty (GM) soil. The elastic modulus of the soil is determined to lay between 7 – 12 MPa (Obrzud & Truty, 2012). The elastic modulus is therefore determined as follows:

$$E = \frac{7 + 12}{2} = 9.5 \text{ MPa}$$

For gravelly soil the Poisson's ratio is mainly determined to be 0.3 to 0.4. A Poisson's ratio for silt lies between 0.3 to 0.35. With both ranges in combination, a Poisson's ratio of 0.35 is chosen for this soil (Bowles, 1996).

Consequently, a solution for the settlement is provided by the Eurocode, considering a linear elastic solution. This solution is prescribed as follows:

$$s_0 = qB \sum_{i=1}^n \frac{I(H_i) - I(H_{i-1})}{E_i} (1 - \nu^2)$$

With  $i = 1$  a since a single layer is considered and the influence factor,  $I = \mu_0 \mu_1$ , the solution will be:

$$s_0 = qB \frac{\mu_0 \mu_1}{E} (1 - \nu^2)$$

The influence factor can be determined using the graphs to obtain  $\mu_0$  and  $\mu_1$  for calculation of the elastic settlement. See graph (Figure 58) and (Figure 59).

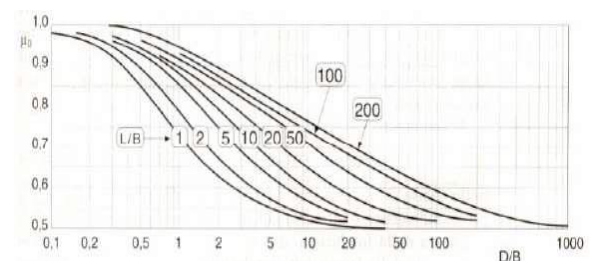

Figure 58: Graph to obtain  $\mu_0$ , for calculation of the elastic settlement (Ozer, 2012).

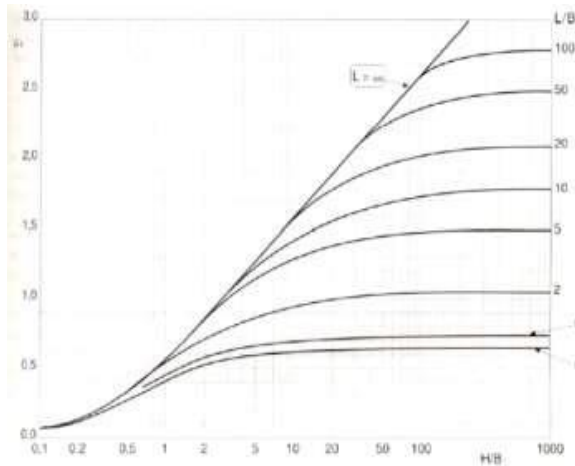

Figure 59: Graph to obtain  $\mu_1$  (1), for calculation of the elastic settlement (Ozer, 2012).

By using the graphs, the parameters and ratios can be determined. The results are show in the table below:

Parameter	Value
$q_{A1}$ (kPa)	43.93
$q_{A2}$ (kPa)	34.49
$B$ (m)	0.6096
$L$ (m)	5.70
$H$ (m)	3.048
$\nu$ (-)	0.35
$E'$ (kPa)	9500
$H/B$	5
$D/B$	1
$L/B$	9.35
$\mu_0$	0.87
$\mu_1$	0.8

Table 41: parameters and ratios

With the parameters, the immediate elastic settlement can be determined, as follows:

For load combination, A1:

$$s_{0,A1} = q_{A1}B \frac{\mu_0\mu_1}{E} (1 - \nu^2) = 0.001218 \text{ m} \\ = 1.218 \text{ mm}$$

For load combination, A2:

$$s_{0,A2} = q_{A2}B \frac{\mu_0\mu_1}{E} (1 - \nu^2) = 0.000923 \text{ m} \\ = 0.923 \text{ mm}$$

The Eurocode prescribes a maximum settlement for granular soils for a serviceability check of: 50 – 75 mm. Comparing the results from the settlement calculation, it can be said that the immediate settlement does not exceed the maximum allowable value.

#### 8.4.4 Second settlement calculations: normalized load-displacement behaviour

The link between the bearing capacity and deformations is shown to exist by Trautmann and Kulhawy (1988). The link exists in the performance of shallow foundations subjected to axial uplift loading. They suggest that the deformations are expressed in terms of the normalized load, which describes the induced load divided by the ultimate bearing load. The deformation should be normalized accordingly with respect to the depth of the foundation. The deformations would occur in the active zone of the soil, as described by the depth of the foundation.

The relation of the normalized Load-Displacement Behaviour of Shallow Foundations in Uplift, per Trautman and Kulhawy 1988, is explained as follows:

$$\frac{q}{q_{uls}} = \frac{\left(\frac{z}{D}\right)}{0.013 + 0.67\left(\frac{z}{D}\right)}$$

With:

$q$  = induced load on the foundation [ $kN/m^2$ ]

$q_{uls}$  = ultimate bearing load [ $kN/m^2$ ]

$z$  = displacement [ $m$ ]

$D$  = depth foundation [ $m$ ]

The normalized load is the inverse of the Factor of Safety, 1/FS. Therefore, to

determine the displacement, the ultimate bearing load and the depth of the foundation must be determined. Usually a Factor of Safety is determined in advance. However, since the pilot building is already built, the normalized load can be determined with the use of the bearing load and the induced load, determined in previous chapters. The depth of the burial remains the same, as well in this case. Primarily the displacement per load combination and therefore, per normalized load is determined. After which, these displacements are compared to the value of  $0.005D$  to determine the settlement acceptability. If the resulting displacement values, exceed the allowable displacement, the required bearing load is calculated. The results for the displacements are as follows (Table 42: displacements):

L.C.	$q$ [ $kN/m^2$ ]	$q_{uls}$ [ $kN/m^2$ ]	$q/q_{uls}$ [-]	$D$ [m]	$z$ [mm]
1	43.93	1879.49	0.0233	0.6096	0.188
2	34.49	646.44	0.0533	0.6096	0.438
3	43.93	1342.49	0.0327	0.6096	0.265
4	43.93	905.02	0.0485	0.6096	0.397
5	34.49	905.02	0.0381	0.6096	0.310

Table 42: displacements

The allowable displacement is  $z = 0.005 \cdot D = 0.003048 \text{ m} = 3.048 \text{ mm}$ .

It can be seen from the results, that the displacements are consequently smaller than the allowable displacement. It seems that the soil is safe against failure due to the primary settlement.

## 8.5 Discussion of results and recommendations

### 8.5.1 Bearing capacity

#### Discussion of Results

To conclude, from the bearing capacity results it can be concluded that the soil is sufficiently strong to withstand the induced loads. Moreover, it can be concluded that the groundwater table influence on the bearing capacity, regarding the current situation, has small impact; and is still safe regarding the induced load. The bearing capacity is, however, a function of the soil parameters, the cohesion and the internal angle of friction. These parameters have been estimated and cannot be assumed to be fully correct and accurate for this specific situation. Furthermore, the unit weights of the soil, are also estimated considering the estimated soil type. However, seen the fact that the unity checks show a substantial safe factor of safety, it can be said that a slight difference in the estimated values, assuming the estimations are not significantly off, will not comprise the safety of the bearing load.

#### Recommendations

Even though the bearing load is sufficiently larger than the current induced load, a few recommendations can be made for further efficiency and accuracy. Firstly, the overburden could be considered larger, with respect to safety, for a fully saturated situation; in case of a monsoon. Subsequently, this situation also has an impact on the groundwater table influence, which will be at ground level. When considering the groundwater table, it is recommended to also investigate the groundwater table at foundation level, with respect to safety. On the other hand, the significance of the groundwater table has

shown to have a slight impact on the full bearing capacity, so it can be argued that it could be considered redundant to conduct this calculation.

Regarding the soil parameters and the soil type, it should be investigated and researched further, to attain a more accurate value for the bearing capacity.

Furthermore, a drained condition was considered for the bearing capacity. It is also recommended to consider an undrained condition, for comparison reasons, to sketch the full safeties of the bearing load.

### 8.5.2 Sliding resistance

#### Discussion of Results

To conclude, the sliding resistance calculations were only a function of the horizontal wind load. It was suspected beforehand that this load would not make a significant impact on the sliding failure of the house. This was suspected, due to the small wind load compared to the relative large weight of the house. It can therefore be argued that this calculation would be redundant. However, seen from the unity checks, an indication is given to what extent of loads the house is safe against sliding. Furthermore, it can be said that from the results the house is safe to sliding as a function of wind load. This calculation should be the base towards horizontal earthquake loads; and the research on sliding resistance with respect to these loads. It should also be said that, for simplicity reasons, the moment because of the movement of the wind load, was not taken into consideration. This is should be considered in future calculations

#### Recommendations

Solely the weight on a single foundation strip is considered for the sliding resistance. It should be investigated, whether to take the whole load of the house, spread over its respective footprint onto the soil. The surface angle of friction, is simply an estimation and a function of the estimated internal angle of friction. Therefore, it is recommended to investigate this parameter in more depth and to a more accurate value, to acquire a more accurate and reliable result for the sliding resistance. Furthermore, it is recommended to do more sliding resistance calculations, with earthquake loads, to research the earthquake safeness of the pilot house.

### 8.5.3 Settlements

#### Discussion of Results

The settlement calculations required a large amount of assumptions and even the rigidly determined parameters were a function of a few estimated parameters and values. For example, the height of the compressible layer is assumed as a function of the width of the foundation. The actual situation and compressible soil layer could be larger than this height, resulting in a larger settlement. Moreover, the elastic parameters, the Poisson's ratio and the Young's modulus, have also been determined with a gravelly-silty loose soil in consideration. However, the total settlement of the compressible layer is lower than the allowable settlement. It should be said that the allowable settlement is derived from the Eurocode and is an allowable settlement for sands. The allowable settlement for gravelly soils is not indicated. For now, it can be said that the immediate settlement is safe.

The results from the second settlement are a factor ten smaller than the allowable settlement. The results show that the house is safe against failure due to primary settlement. If the results are compared to the first settlement calculations, the results give a slight difference in settlement. This probably due to the totally different nature of the calculations. If the results from the first settlement calculations are compared to the second allowable settlement boundary condition, it shows that the calculated settlement are still smaller.

The preference of both calculations goes to the first calculation because of the more researched nature. The graphs show that these calculations and values are derived from actual results. The second calculations use a normalised value in combination with an assumed and estimated value, which gives room for large errors and

#### Recommendations

It should be said that no actual real data of the soil layers is acquired, which, in case of settlement calculations, is desirable to have. It is therefore, recommended to acquire and research more data on the (compressible) soil layers. Namely, an assumption is made that a single compressible homogenous layer of the estimated soil type is situated. This is a large assumption and should be clarified by tests, such as plate loading and penetration tests.

Furthermore, only immediate settlement calculations were performed. It is also desirable to know the consolidation settlement. It is therefore recommended to perform long-term calculations on the settlement of the soil.

# 9 Quasi-static calculations

## 9.1 Acceleration of initiation of collapse mechanism

After analysing the structural performance of the house in an ordinary working situation, its general behaviour during more likely earthquake situation has been analysed. Before proceeding with linear static analysis, the acceleration of initiation of collapse mechanisms has been calculated for the wall compartments to have a first overview about the response of them during horizontal shaking forces. The values of the maximum allowable acceleration necessary to keep the house safe during an earthquake,  $a_0^*$ , have then been compared to the expected ground acceleration values, PGA, linked to the specific site. Further analysis has been conducted even about the increase of the PGA due to the height above the ground level where the compartments are located. The values of the maximum allowable acceleration have been calculated only for the tallest compartments take make the wall, in fact the intermediate one (LEVEL B). Due to the highest height of them, if they were verified as safe, the other two level of compartments would be as well thanks to their less critical geometrical dimension and slenderness.

As already mentioned, each compartment has been realized between two reinforced concrete bands, that have been assumed rigid so far. However, on-site construction mistakes could have compromised the actual rigidity of these elements, not guaranteeing a cooperative behaviour between structural elements anymore.

These kinds of imperfections should be considered. A comparison between the acceleration that would cause the initiation of the collapse mechanism between the two situations where a compartment is made rigid at the two bottom and top sides (working bands) or only one has been made as well, to give a further idea about the importance of the construction stages that should be followed.

### 9.1.1 1<sup>st</sup> scenario: compartment made rigid only at the bottom side

To give a first overview about the differences caused by the two specific boundary conditions, a simple example has been considered. It has been analysed good quality wall, assuming its behaviour as a unique rigid body, without applied loads on the top but only its own self-weight. The failure mechanism would happen as overturning around a fixed point at the base of the wall itself. The analysed factor to cause this collapse is the necessary acceleration factor that would make this possible,  $a_0$ . To proceed in this scenario, the principle of virtual works has been used.



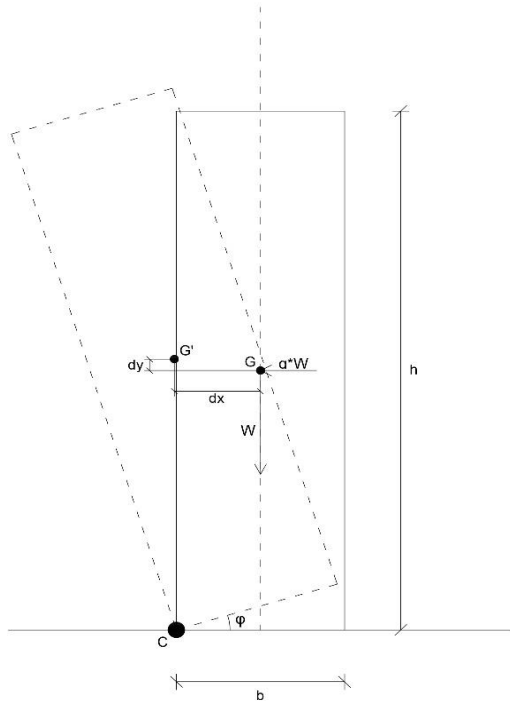

Figure 60: static scheme of wall overturning around point C

Due to the rotation of the wall,  $\phi$ , around the bottom point C, the two virtual movements of the barycentre will be:

$$dx = \phi \frac{h}{2} ; dy = \phi \frac{b}{2}$$

The external forces virtual work ( $L_{est}$ ) is then made equal to 0, thanks to the rigid body behaviour of the wall, making a virtual work thanks to internal forces null.

$$L_{est} = -W*dy + \alpha W*dx = -W*\phi \frac{b}{2} + \alpha W*\phi \frac{h}{2}$$

imposing  $\phi=1$  as virtual movement, the acceleration factor necessary to cause overturning of the wall will be:

$$\alpha_0 = \frac{b}{h}$$

*note:  $\alpha_0$  is only a factor that is necessary to calculate the actual acceleration that would cause the initiation of the collapse mechanism,  $\alpha_0^*$ .*

### 9.1.2 2<sup>nd</sup> scenario: compartments made rigid even at the top side by concrete bands

In the case the concrete bands at the top and the bottom sides of each compartment make the compartments themselves rigid, the collapse mechanism would be initiated with the spall out of the vertical section at a certain height included in the total one of the wall. Even in this scenario, the principle of virtual works has been used once again to determine the acceleration factor  $\alpha_0$ . This implies the assumption of the rotation  $\phi$  equal to 1. A comparison will be then made between the two scenarios and the actual acceleration of initiation of collapse will be calculated.

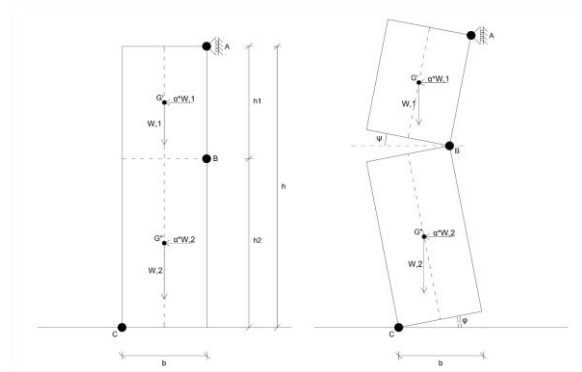

Figure 61: static scheme of wall spalling out rotating around a certain point B

As in the previous case, only the self-weight forces of the wall have been considered for the collapse mechanism to make the calculations process easier. Those that will collaborate about the collapse behaviour are the horizontal ones  $\alpha_0 W_1$  and  $\alpha_0 W_2$ , while vertical forces work as stabilizing loads. In a general case, it is not possible to know beforehand at what height the spalling out will happen: the two heights  $h_1$  and  $h_2$  are then expressed function of the unknown "x", which is the quote along the vertical direction:

$$\phi * h_2 = \Psi * h_1 \rightarrow \Psi = \phi * \frac{h_2}{h_1} = \frac{h_2}{h_1}$$

imposing then:

$$h_1 = \frac{1}{x} h; h_2 = \frac{x-1}{x} h;$$

$$\Psi = x - 1;$$

knowing the dimensional parameters of reference for the movements of the two bodies, it is now possible to express the virtual movements of each barycentre as:

$$G': dx_{G1} = \Psi * \frac{h_1}{2} = \frac{h}{2} * \frac{x-1}{x};$$

$$dy_{G1} = b * \phi + \frac{b}{2} * \Psi = b + \frac{b}{2} (x - 1) =$$

$$(1 + x) * \frac{b}{2};$$

$$G'': dx_{G2} = \phi * \frac{h_2}{2} = \frac{x-1}{x} * \frac{h}{2};$$

$$dy_{G2} = \frac{b}{2} * \phi = \frac{b}{2};$$

Knowing every virtual movements of relevant points of the two bodies (barycentre's), it is now possible applying the principle of virtual works for the mentioned system. Thanks to the rigid body behaviour of the compartments, the internal virtual work will be equal to 0 as it has been for the 1<sup>st</sup> scenario, while the external virtual work is determined by the applied loads times their relative virtual movements:

$$L_{int} = L_{est}; \alpha_0 W_1 * dx_{G1} + \alpha_0 W_2 * dx_{G2} - W_1 * dy_{G1} - W_2 * dy_{G2} = 0;$$

substituting the values of virtual movements and relative applied loads, the acceleration factor  $\alpha_0$  expressed in function of the height coordinate  $x$  will be:

$$\alpha_0(x) = \frac{b}{h} * \frac{2x}{(x-1)}$$

It is then reasonable to assume that the actual division of two different rigid bodies of each compartment (point B) would happen at the middle height of the total vertical dimension, that implies  $h_1 = h_2 = \frac{h}{2}$ . The

acceleration factor for this scenario, called in this occasion  $\alpha_{0,2}$ , will be then:

$$\alpha_{0,2}(x = \frac{h}{2}) = \frac{4b}{h} = 4 * \alpha_0,$$

where  $\alpha_0$  = acceleration factor relative to the 1<sup>st</sup> scenario.

The comparison between these two different failure mechanisms gives an overview about the importance of the connections, and then the rigidity, between the wall compartments and the reinforced concrete bands. It is easily visible how the acceleration factor increases by a factor of 4 if the compartments are well connected both at the top and the base sides. These acceleration factors,  $\alpha_{0,1}$ , are then used to calculate the actual acceleration the walls are subjected to in an earthquake situation, which will be explained later. It must be said that these two considered scenarios do not consider an external load application from the top side of the compartments. Assuming the connections between wall compartments and reinforced concrete bands are strong and well executed enough to guarantee a double bond at both the top and base section, the acceleration of initiation of collapse has been calculated for each compartment considering the 2<sup>nd</sup> scenario explained above, even considering the external applied loads. The calculations that have been conducted are explained below. However, the same principle of virtual works has been used.

### 9.1.3 Calculation of acceleration of initiation of collapse mechanism

As already mentioned for the 2<sup>nd</sup> scenario described above, the mechanism of collapse will happen with the creation of a rotation point at a certain height in the vertical section of the brick compartment. The assumption of a rigid-body behaviour of the wall already consider the maximum collaboration between elements the wall has been built (bricks, mortar and steel bars). The acceleration factor necessary for the breaking a condition of equilibrium,  $\alpha_0$ , starting the division and next rotation of the rigid bodies, is calculated using the principle of virtual works [Figure]:

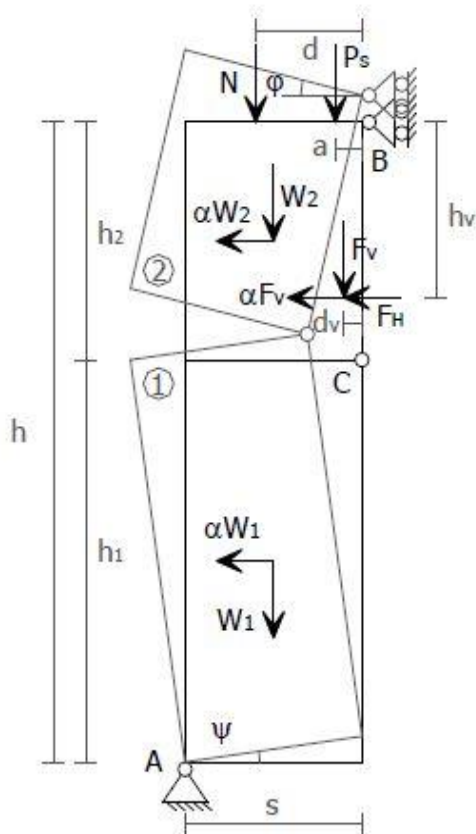

Figure 62: static scheme of wall mechanism of collapse

Figure 62 shows a general scenario where many forces are transmitted to the wall from other building elements, as:

$P_s$  = load from the upper floor, applied in  $a$ ;

$F_v, F_H$  = loads from inner arches, applied in  $h_v$ ;

$N$  = load from upper wall portions;

$W$  = self-weight of the compartment;

However, in our case, looking at the structure of the house, it is reasonable to say that  $P_s = F_H = F_v = 0$ .

The principle of virtual works related to this situation will be then:

$$\alpha * (W_1 * \delta_{1x} + W_2 * \delta_{2x}) - W_1 * \delta_{1y} - W_2 * \delta_{2y} - N * \delta_{Ny} = 0$$

the height that the intermediate rotation would start at is not known before hand; the expression of  $\alpha$  is then written as function of the parameter  $x$ , which means:

$$h_1 = \frac{x-1}{x} * h; h_2 = \frac{h}{x};$$

$$W_1 = \frac{x-1}{x} * W; W_2 = \frac{1}{x} * W;$$

$$\text{with } x = \frac{2N * \sqrt{8N^2 + 8N * (W_1 + W_2)}}{2N};$$

It will then result that:

$$\alpha = 2 * \frac{(x-1) * (N * d) + s * (W + N)}{(x-1) * (W * \frac{h}{x})}$$

the acceleration factor,  $\alpha_0$ , is then used to calculate the actual acceleration of initiation of collapse,  $\alpha_0^*$ :

$$\alpha_0^* = \frac{\alpha_0 * g}{e * FC};$$

where:

$g$  = acceleration of gravity =  $9,81 \frac{m}{s^2}$ ;

$FC$  = reduction factor = 1,35;

$e^*$  = fraction of collaborative mass on the  
cinematics =  $\frac{g^* M^*}{\Sigma P_i}$ ;

$M^*$  = collaborative mass on the cinematics =  
 $= \frac{(\Sigma P_i^* \delta_{i,x})^2}{g^* \Sigma P_i^* (\delta_{i,x})^2}$ ;

## 9.2 Static linear analysis

It is already well known that in an earthquake situation dynamic forces are applied on the structural elements of a certain building, with a certain frequency and vibration. However, DM 2008 gives the possibility to study the behaviour of a certain building in an earthquake situation applying statically forces on the load bearing elements and analysing their response. The static forces are calculated based on the characteristics of the building and the site where it has been built. To apply this type of analysis, however, the house must fulfil certain geometric requirements as indicated by the normative included in the DM 2008, as regular size and height and an own period of the building lower than a certain value ( $T_D$ ). It has been ensured that, for the house built in Ratankot, these requirements are fulfilled and this analysis is applicable.

### 9.2.1 Seismic forces

Proceeding with a static linear analysis, static forces are applied horizontally on the house, as already mentioned. In this case, even the movements due to loads application must be considered linear. Assuming a static structural scheme of the house as already done previously, with rigid concrete bands and monolithic wall compartments, the applied forces on the house will be (Figure 63):

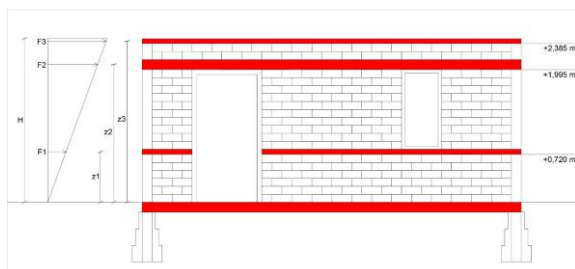

Figure 63: earthquake forces distribution between the building floors

The entity of the applied forces due to the earthquake situation will be:

$$F_i = F_h \frac{z_i * W_i}{\sum z_j * W_j}$$

where:

$W_i$  = weight of the specific floor;

$z_i$  = height of the barycentre of each floor;

$$F_h = S_d(T_1) * W * \frac{\lambda}{g};$$

with:

$S_d$  = coordinate of response spectrum of the house at a time  $T_1$ ;

$T_1 = 0,05 * H^{3/4}$ , principal own period of vibration of the house;

$\lambda$  = correction coefficient = 1,0;  $g$  = acceleration of gravity;

The principal own period of vibration of the house,  $T_1$ , is compared to the actual spectrum of response of the house itself in an earthquake dynamic situation to find the coordinate  $S_d(T_1)$ , as visible from a generic sample of spectrum of elastic response at Figure 64. Assuming a soil composition category of "C" (middle compaction, no close water layers), the relative reference factors will be:

SOIL CATEGORY	S	T <sub>B</sub>	T <sub>C</sub>	T <sub>D</sub>
A	1,0	0,15	0,40	2,0
B, C, D	1,25	0,15	0,50	2,0
E	1,35	0,20	0,80	2,0

Table 43: relative reference factors

The principal own period of vibration of the house,  $T_1$  is equal to:

$$T_1 = 0,05 * (2,46 \text{ m})^{3/4} = 0,098 \text{ s} < T_B$$

$S_d(T_1)$  will be then calculated for the domain of the spectrum of response where  $0 < T_1 < T_B$ , which is:

$$S_d(T_1 < T_B) = a_g * S * [1 + \frac{T_1}{T_B} * (\frac{2,5}{q} - 1)] = 1,319;$$

where:

$$q = \text{shape factor} = K_0 * q_0 = 4,4;$$

$a_g$  = acceleration factor related to the soil composition category = 0,15\*g;

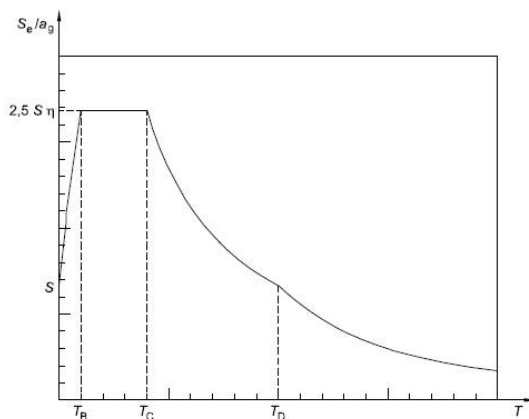

Figure 64: generic spectrum of elastic response

The earthquake forces will be determined then based on the self-weight of each floor of the building (Table 44: self-weight of each floor of the building) (Table 44), as:

LEVEL	$W_i$ [kg]	$F_{h,tot}$ [kg]	$z_i$ [m]	$W_i * z_i$ [kg*m]
3	3923,088	2287,32	2,265	8885,79
2	10631,09	2287,32	1,395	14830,37
1	6865,14	2287,32	0,36	2471,45

LEVEL	$W_i * z_i / \sum W_j * z_j$	$F_{h,i}$ [kg]	$F_{h,i} + 0,3 F_{h,i}$ [kg]
3	0,339	776,12	1008,95
2	0,566	1295,34	1683,94
1	0,094	215,87	280,63

Table 44: self-weight of each floor of the building

where:

$$F_h = S_d(T_1) * W * \frac{\Delta}{g}$$

with  $W$  = total weight of the house [kg];

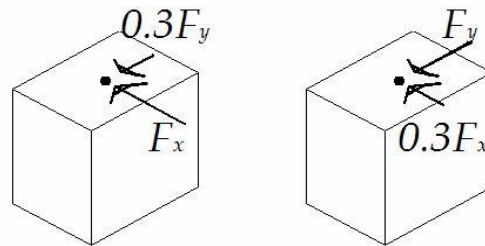

Figure 65: combination of applied horizontal forces

*note: the actual force that must be applied on the barycentre of each floor must consider both the forces that are applied in both the directions of the space (x,y), neglecting the vertical component (z) for cases where the structural design does not have particular shape or size, where the z-component could have non-negligible impact (Figure 65).*

The forces caused by the earthquake condition will be applied on the barycentre of rigidity of each floor of the house. The different positions of the barycentre of rigidity with the geometric ones (the barycentre of mass) would cause torsional moment, with a torsional hub inside the floor area of the house. It must be said that in this situation the barycentre of rigidity of each floor differs from those already determined when static calculations of a working situation of the house happened, in matter of wind loads. In fact, in this specific scenario, even the inner walls will be considered as collaborative, for the nature of the applied forces themselves, which does not depend on the wind but on the ground shaking. Their geometric and rigidity contributes will be considered for the determination of both the geometric and rigidity barycentre.

The coefficients of distribution (named  $\alpha$ ) of the horizontal loads applied on each compartments of the same level depends on the geometric characteristics of the wall compartments themselves as mentioned below:



$$\alpha = \frac{K_{x,y,i}}{\Sigma K_{x,y,i}} + C_T$$

with x,y directions of the considered compartment. Assuming the behaviour of the structural elements as their equivalent springs and looking at their boundary conditions, the rigidity of each compartment,  $K_i$ , can be calculated as:

$$K = \frac{1}{\frac{h^3}{\beta \cdot E \cdot I} + \frac{\kappa \cdot h}{G \cdot A}}$$

where:

$h_i$  = height of the compartment;

$\beta$  = type of construction factor = 2,0;

$E$  = Young's modulus of the bricks;

$I_i$  = Moment of inertia of each compartment;

$\kappa$  = shape factor (1,2 if rectangular elements);

$G$  = Shear modulus;

$A_i$  = horizontal surface of each compartment;

To determine  $C_T$ , the relative formula will be written regarding the walls along the x-direction for simplicity, noting that the same calculations would be valid even for those along the y-one inverting the values relative to the considered direction:

$$C_T = \frac{(K_{x,i} \cdot (y_{G,i} - Y_R) \cdot e_{y,total})}{(\Sigma K_{x,i} \cdot (y_{G,i} - Y_R)^2 + \Sigma K_{y,i} \cdot (x_{G,i} - X_R)^2)}$$

where:

$y_{G,i}$  = distance from barycentre of each compartment to the centre of mass of the level;

$$Y_R = \frac{K_{x,i} \cdot y_{G,i}}{\Sigma K_{x,i}}$$

$e_{y,total}$  = total eccentricity along y-direction =  $e_y + e_{y,additional}$  where:

- $e_y = Y_C - Y_R$  (with  $Y_C$  = y-coordination of the centre of mass of the whole compartment level);
- $e_{y,additional} = 0,5 \cdot L_y$  (with  $L_y$  = length of the compartment along y-direction);

The application of horizontal forces,  $F_i$ , in the barycentre of rigidity causes torsional moment, calculated as:

$$M_{T,x,i} = F_{h,i} \cdot [(X_G - X_R) + 0,05 \cdot L_x]$$

$$M_{T,y,i} = F_{h,i} \cdot [(Y_G - Y_R) + 0,05 \cdot L_y]$$

This must be calculated for each floor. The application of an additional distance of 5% of the total length of the house along the relative direction is imposed by the normative NTC 2008 to consider a factor of imperfection. The contribution of torsional moment would be then distributed between the load bearing walls depending on their rigidity and the distance between their barycentre's and the barycentre of rigidity. However, the torsional effects caused by the application of  $F_h$  in the barycentre of rigidity have considered only indirectly inside the determination of the second coefficient of distribution of forces,  $C_T$ .

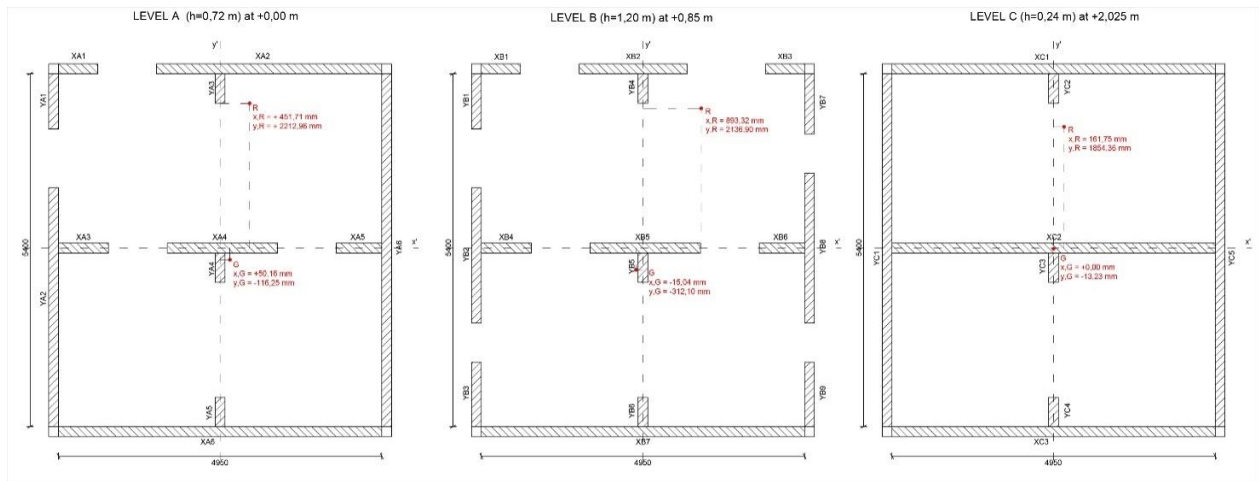

Figure 66: coordinates of geometric ( $X_G; Y_G$ ) and rigidity ( $X_R; Y_R$ ) barycentres

## 9.2.2 Linear static verification

After the forces caused by an eventual earthquake situation have been determined, it has proceeded verifying the structural response of the building elements when loaded. The three analysis that have been conducted are:

- press-flexion on-plan;
- shear on-plan;
- press-flexion out-of-plan;

It must be said that the wall compartments have been considered as simple brick walls, without considering the contribution of steel bars. This has been done due to the lack of information about the position of the steel bars in certain parts of the house. They would be reconsidered only in the case that the walls, made of bricks only, would not fulfil the verifications as indicated from NTC 2008.

## Press-flexion on-plan

The verification about the level of bending at the base of wall is calculated using the *stress-block*, relatively to the compressed part of the wall base. In the case that the

maximum allowable bending stress at the base of the wall is higher than the imposed

loads, the overturning on the plan of the wall is negated (Figure 67).

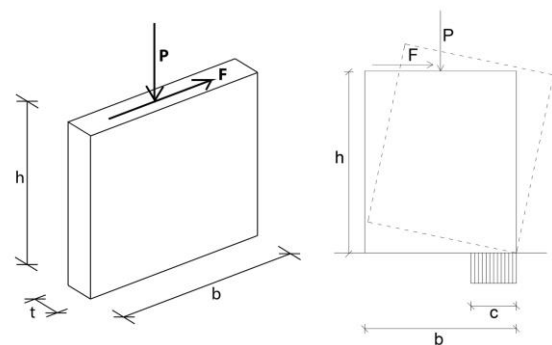

Figure 67: on-plan press-flexion verification

The verification would be then satisfied if  $M_{Ed} < M_{Rd}$ , where:

$$M_{Ed,i} = F_i * h_i$$

$$M_{Rd} = \left( b^2 * t * \frac{\sigma_0}{2} \right) * \left( 1 - \frac{\sigma_0}{0,85 * f_d} \right)$$

where:

$b; t; h$  = dimensions of the wall compartments;

$f_d$  = design compression strength;

$\sigma_0$  = compression stress at the base of the wall =  $\frac{P}{b * t}$ ;

### Shear on-plan

The shear at the base of the wall,  $V_{Ed}$ , caused by the application of horizontal forces applied at the top section must be lower than the actual shear resistance of the compartment,  $V_{Rd}$ . The shear resistance is calculated considering the partialisation of the reactive section and the Coulomb behaviour of the material (Figure 68).

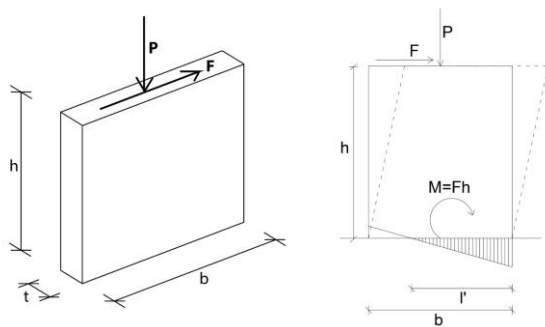

Figure 68: shear stresses of the wall vertical section and partialisation of the reactive wall section

The imposed stresses that must be borne by each compartment are equal to the horizontal forces applied at the top section due to the earthquake situation, then:

$$V_{Ed} = F_{h,i}$$

It must be verified that:  $V_{Ed} < V_{Rd}$ , with:

$$V_{Rd} = l' * t * f_{vd}$$

$f_{vd}$  = design shear resistance of the material assuming Coulomb behaviour of the material

$$= \frac{f_{vk}}{\gamma_m}$$

$t$  = thickness of the compartment;

$$l' = 3 * \left( \frac{b}{2} - \frac{M}{P} \right);$$

where:

$M = F_{h,i} * h_i$  = bending stress at the base of the wall caused by horizontal forces,  $F_{h,i}$ ;

$P$  = compression loads applied on the top section of each compartment;

$b$  = length of each compartment;

The Coulomb behaviour of the material has been assumed. The relative shear resistance,  $f_{vk}$ , will be then:

$$f_{vk} = f_{vk,0} + 0,4 * \sigma_n = f_{vk,0} + 0,4 * \frac{P}{l' * t};$$

## Press-flexion out-of-plan

The press-flexion out-of-plan stresses have been calculated related to a situation where the connections between brick compartments and reinforced concrete bands have been assumed without imperfections. This means that the walls overturning would not happen as a rotation of the whole wall around a point at the base, but that the collapse mechanism would happen as a rotation at three hinges, with the creation of one at a certain quote at the wall height. The presence of steel bars into the walls has been considered assuming the behaviour of the wall as a rigid body. No relative inner movements would then happen. This verification checks if the acceleration necessary to activate the collapse mechanism,  $\alpha_0^*$ , is higher or lower than the acceleration that must be expected during an earthquake situation,  $S_d(T_1)$  (Figure 69).

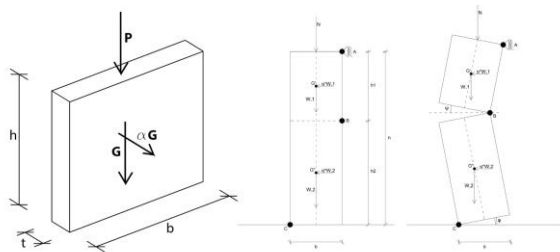

Figure 69: scheme of collapse assuming a 3-hinges collapse mechanism

To calculate the acceleration necessary to activate the collapse, the principle of virtual works has been used, as explained in the previous section “*Calculation of acceleration of initiation of collapse mechanism*”. The verification must be taken satisfactory when:  $\alpha_0^* > S_d(T_1)$ , with  $\alpha_0^*$  calculated for each compartment.

## 9.3 Conclusions and recommendations

The load bearing capacity of the house built in Ratankot is given to the CSEB brick walls, a common constructive technology based on the mutual use of bricks, concrete and steel rebar's. The steel rebar's are located into holes made in the shape of the bricks, then filled with concrete. To verify the structural reliability of the house, static calculations have been conducted, as well as structural linear analysis as indicated by the Eurocode. Due to the uncertainty of the position of the steel rebar's and the lack of technical drawings regarding the details of the built-house, all the calculations have been conducted as if the rebar's did not be located. This way to proceed can be even seen as a further factor of safety kept during the structural verification of the state of the house.

All the calculations that have been conducted are shown into the Appendix; specifically, there will be Excel tables with all the relations already above-described theoretically. Under the application of static loads previously determined, the structure of the house offers an adequate structural performance generally. Especially regarding the structural response to the application of static vertical and horizontal loads, the stresses shown happening into the structures result to be lower than the structural capacity of the used materials, already diminished by adequate safety factors. However, there are few walls compartments that, following the Eurocode, do not match its guidelines and indications. The values of eccentricities caused by the application of axial loads and out-of-plane moment result to be much higher than what advised for many walls compartments of the second level (the higher one), and in some cases, even larger than the actual thickness

of the walls. Finally, the structural performance of the compartments is generally verified regarding their compression strength, on-plan and out-of-plan bending, the shear forces happening at the bottom of each section and the resistance against punctual loads generally.

In the structural linear analysis, the earthquake horizontal forces have been calculated and then applied on the structure of the house. In this stage, it could be seen that the structural response of the house was generally enough strong to bear them. The ultimate moment of the compartments has been shown to be always higher than the one caused by the forces application. On the other hand, for some compartments the caused shear-on-plan stresses might be too high to be bear. It must be said that the shear structural response should be given by the steel rebar's, that however have not been considered at all. If rebar's were considered, the structures would have probably fulfilled its safety requirements. Further analysis should be conducted eventually to verify this statement.

Finally, remarks must be underlined about the acceleration needed to start the mechanism of collapse of each compartment. An Excel file with different input parameters has been made available to calculate the actual collapse acceleration related to the 3 points collapse mechanism; looking at this mechanism, thanks to the modest height of the compartments, all of them have been verified as safe. However, the assumption that a 3-points collapse mechanism would happen is already a not-simple assumption. In fact, this implies that the connections between the rebar's and the concrete bands for both the bottom and top parts of each compartments will be strong enough to bear the stresses, causing the failure at the middle height of the

compartment eventually. In the case this assumption would not be valid anymore, as it might be even in this case looking at the actual quality of the construction, a 1-point collapse mechanism would happen, where the rotation point would be the bottom of the compartment. If this was the case, due to the lower acceleration of the ground needed to initiate this collapse mechanism, many compartments might not be able to bear the ground movements and the acceleration related to them.

# 10 Pseudo-static calculations on foundations

Static calculation on the foundation have been conducted, for the bearing capacity, the sliding resistance and the immediate settlement of the soil. These calculations, as static already explains, consider a general situation without any earthquake influence. Consequently, since the project takes shock safe building in consideration, it is desirable and required to predict, to some degree, the behaviour of the pilot house during an earthquake situation. Within the timespan of the project, full dynamic calculations were too farfetched, even though these could predict the behaviour of the house to a more accurate degree. Nevertheless, seismic calculations should be conducted. Therefore, pseudo-static or quasi-static calculations were consulted for the matter of simplicity and efficiency, but also a base for further dynamic calculations. With respect to the safety of the foundation during an earthquake situation, the seismic bearing capacity, by means of pseudo-static calculations, is subsequently determined.

To conduct such calculations, firstly the seismic acceleration factor must be determined, which is a function of the Peak Ground Acceleration, later explained in more detail. After which, the seismic bearing capacity factors are determined for several situations, but predominantly for the inertia forces on the soil and the inertia forces transmitted by the superstructure, being the pilot house. These factors, remain a function of the load combinations, which should be taken into consideration. Consequently, the

rigid bearing capacity factors are determined, for example the shape factors. The overburden is determined and load combination factors. Previously, it was determined under which load the soil is induced, because of the weight of the house. These loads will be shortly mentioned. Ultimately, the bearing load is determined using the seismic bearing capacity factors and subsequently a unity check will be conducted to determine to what extent the bearing load is safe as opposed to the induced load.

## 10.1 Seismic acceleration factor

The seismic acceleration factor can be distinguished in the horizontal seismic acceleration factor and the vertical seismic acceleration factors,  $k_h$  and  $k_v$  respectively. Both these parameters can be determined using the Peak Ground Acceleration, or PGA. This is the maximum acceleration at ground level at a specific location and is a function of the gravitational acceleration. The acceleration occurs in many different directions and can therefore be distinguished in vertical and horizontal direction. The PGA for the vertical direction is usually smaller and a function of the horizontal direction.

For the location in Kathmandu valley, where Ratankot is located, a study was done to predict the average PGA and comparison is made between these results and the measurements done on the earthquake in 2015 in Gorkha. Per article (Goda, et al., 2015), the estimated PGA with 10% probability of exceedance in 50 years (i.e. return period of 475 years) in Western Nepal ranges from 0.5 to 0.6 g and Eastern Nepal from 0.3 to 0.6 g. The PGA considered in 2015 in Gorkha was less than the PGA estimates. However, it is predicted that the earthquakes in the future will be of a higher



magnitude than the earthquake in 2015. With respect to safety, it is therefore determined that the maximum PGA is 0.6 for the pseudo static calculations on the bearing capacity.

Using this PGA, the seismic acceleration factors can be determined, as follows:

$$PGA = k_h \cdot g \rightarrow k_h = 0.6$$

Following the Eurocode, the horizontal seismic acceleration factor is determined as follows:

$$k_h = \alpha \cdot \frac{S}{r}$$

With:

$\alpha$  = The ratio of the design ground acceleration on type A ground,  $a_g$ , to the acceleration of gravity  $g$ ;

$S$  = the soil parameter of EN 1998-1:2004, 3.2.2.2.

$r$  = factor that considers the type of retaining structure

Unfortunately, these factors are all not applicable to the seismic situation and soil types in Ratankot. It can therefore not be used. However, the Eurocode does prescribe a function for the vertical seismic factor, which may be used since it is simply a ratio and a function of the horizontal acceleration factor.

$$k_v = \pm 0.5k_h \text{ if } a_{vg}/a_g \text{ is larger than } 0,6$$

$$k_v = \pm 0.33k_h \text{ if otherwise}$$

With:

$a_{vg}$  = Design ground acceleration in the vertical direction

$a_g$  = Design ground acceleration on type A ground

With this in consideration, it shall later be determined what the vertical acceleration factor will be.

## 10.2 Seismic bearing capacity

The seismic bearing capacity is determined by using the method of Cascone & Casablanca (2016) (Cascone & Casablanca, 2016). The static bearing capacity equation of Brinch Hansen is used to determine the seismic bearing capacity, but rather than using the normal bearing capacity factors, the seismic bearing capacity factors are used. These factors are derived by using the method of characteristics and finite element method. Furthermore, these factors are determined using the internal angle of friction, the horizontal acceleration factors and the friction angle between the foundation and the soil. Subsequently, a distinction is made between the soil inertia effects and the superstructure inertia on the soil effects. Rather than combining these effects, they are first determined using a decoupled system. After which seismic bearing capacity factor correction factors are determined, for each of the inertia situations separately. Superposition of these factors is then applied and multiplied by the static bearing capacity factors.

### 10.2.1 Load combinations

Load combinations determining foundation strip:

As previously noted, different load combinations are considered, when calculating the seismic bearing capacity following (EN.1997-1, 2004). The following combinations are considered, calculating the seismic bearing capacity:

$$DA11 = A1 + M1 + R1$$

$$DA12 = A2 + M2 + R2$$

$$DA2 = A1 + M1 + R2$$

$$DA3 = (A1 \text{ or } A2) + M2 + R3$$

However, for simplicity reasons, the material load combination factors are not considered.

Where the R factors are load combinations factor (EN.1997-1, 2004).

$$R1 = 1.0$$

$$R2 = 1.4$$

$$R3 = 1.0$$

For the induced and current load, two load combinations are considered, the A1 and A2 load combinations, derived from the Eurocode. Its respective load factors (Table 45) are:

Load combination	Permanent load factor $\gamma_G$	Variable load factor $\gamma_Q$
A1	1.35	1.50
A2	1.00	1.30

Table 45: respective load factors

Consequently, the loads per load combination is determined, as follows:

$$F_{tot,strip} = \gamma_G \cdot G_{permanent} + \gamma_Q \cdot Q_{variable}$$

### 10.2.2 Loads on structure

Previously it has been determined that the maximum load on a single strip is 132.46 kN for A1 load combinations and 104.056 kN for A2 load combination. However, to determine the bearing capacity, it is required to attain the maximum q-load on the soil. The vertical q-load will therefore be:

$$q_{v,max} = \frac{F_{v,max}}{A_{strip}} = \frac{F_{v,max}}{B_{strip} \cdot L_{strip}} \text{ kN/m}^2$$

For the load combination, A1:

$$\begin{aligned} q_{v,max} &= \frac{F_{v,max}}{A_{strip}} = \frac{F_{v,max}}{B_{strip} \cdot L_{strip}} \\ &= \frac{132.46}{(2 \cdot 0.3048) \cdot 4.95} \\ &= \frac{132.46}{3.017520} = 43.93 \text{ kN/m}^2 \end{aligned}$$

For the load combination A2:

$$\begin{aligned} q_{v,max} &= \frac{F_{v,max}}{A_{strip}} = \frac{F_{v,max}}{B_{strip} \cdot L_{strip}} \\ &= \frac{104.056}{(2 \cdot 0.3048) \cdot 4.95} \\ &= \frac{104.056}{3.017520} = 34.49 \text{ kN/m}^2 \end{aligned}$$

$q_{v,max}$  = Maximum q-load on the foundation strip [ $kN/m^2$ ]

$F_{v,max}$  = Maximum point load on the foundation strip [ $kN$ ]

$A_{strip}$  = Area foundation strip [ $m^2$ ]

$B_{strip}$  = Width of foundation strip [ $m$ ]

$L_{strip}$  = Length of foundation strip [ $m$ ]

### 10.2.3 Seismic bearing capacity factors

#### Soil inertia forces on bearing capacity factors

The earthquake bearing capacity factors as an effect of soil inertia forces are considered for three different load conditions. Shown below (Figure 70):

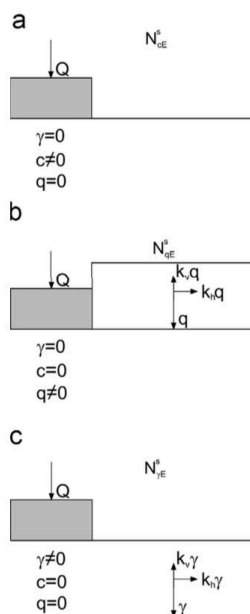

Figure 70: Soil inertia effects (Cascone & Casablanca, 2016).

Each bearing capacity factor, for this inertia situation, is indicated as follows:

$$N_{cE}^s, N_{qE}^s, N_{\gamma E}^s$$

Considering the soil inertia forces on the bearing capacity factors, it must be stated that the factors  $N_{cE}^s, N_{qE}^s$  are determined by taking a weightless medium, so no inertial effects will occur in the soil beneath the foundation due to surcharge of the superstructure. However, inertial forces can occur in the soil due to embedding of the foundation, in the surcharge  $q$ . Meaning that for  $N_{cE}^s$  the surcharge  $q$  is taken to be zero. Subsequently, the value for  $N_{qE}^s$  is estimated assuming  $c$  is zero.

The bearing capacity factors mentioned above, have been determined using the method of characteristics by Cascone & Casablanca (2016), for  $k_v = 0$  and different value for the angle of internal friction and  $k_h$  (Cascone & Casablanca, 2016).

Loading situation, A:  $N_{cE}^s$

Since the surcharge  $q$  has been assumed to be zero, this earthquake bearing capacity factor  $N_{cE}^s$  agrees with its static factor  $N_c$ . Expressed as follows:

$$\begin{aligned} \gamma &= 0 \\ c &\neq 0 \\ q &= 0 \\ N_{cE}^s &= N_c \end{aligned}$$

Loading situation, B:  $N_{qE}^s$

The value for  $N_{qE}^s$  is estimated assuming the following values:

$$\begin{aligned}\gamma &= 0 \\ c &= 0 \\ q &\neq 0\end{aligned}$$

$$\begin{aligned}\gamma &\neq 0 \\ c &= 0 \\ q &= 0\end{aligned}$$

$$N_{\gamma E}^s = 7.91$$

As opposed to the value  $N_{cE}^s$ , the value for  $N_{qE}^s$  does not agree with its static factor. This value can be acquired inclining the later surcharge  $q$ , to the value of the horizontal stress expressed as follows:

$$N_{qE}^s = k_h \cdot q$$

With a value of 0.65 for  $k_h$  and an internal angle of friction ( $\varphi$ ) of  $35^\circ$ , the value for  $N_{qE}^s$  can be determined from the values obtained by Cascone & Casablanca (2016), using the Method of Characteristics. It then follows that:

$$N_{qE}^s = 15.98$$

Loading situation, C:  $N_{\gamma E}^s$

For determining the value for  $N_{\gamma E}^s$ , the surface angle of friction must be compared to the internal angle of friction, to determine the roughness of the foundation as opposed to the soil. Since the angle of skin friction of the foundation has been determined to be  $\delta = 0.7\varphi$  it can be said that the foundation is more perfectly rough ( $\delta/\varphi = 1$ ) rather than perfectly smooth ( $\delta/\varphi = 0$ ). Consequently, looking at the seismic bearing capacity factors of Cascone & Casablanca (2016), the value is determined as follows (Cascone & Casablanca, 2016):

As can be seen, these seismic values for the bearing capacity factors are significantly smaller than the static bearing capacity factors. Subsequently a correction factor can be computed by comparing the static and seismic factors:

Correction factors for the seismic bearing capacity factors because of soil inertial effects:

$$e_{cE}^s = \frac{N_{cE}^s}{N_c} = 1$$

$$e_{qE}^s = \frac{N_{qE}^s}{N_q} = \frac{15.98}{33.259} = 0.552$$

$$e_{\gamma E}^s = \frac{N_{\gamma E}^s}{N_\gamma} = \frac{7.91}{45.176} = 0.461$$

An empirical solution has been developed for the correction factors for  $q$  and  $\gamma$ , from the computed values  $N_{cE}^s, N_{qE}^s, N_{\gamma E}^s, k_h, k_v$  using the method of characteristics. This empirical solution is expressed as follows:

$$\begin{aligned}e_{jE}^s &= \frac{N_{jE}^s}{N_j} \\ &= (1 - A \frac{k_h}{1 - k_v} \cot \varphi)^B \sqrt{k_h^2 + (1 - k_v)^2}\end{aligned}$$

With  $j = q$  or  $\gamma$ . And:

$$A = 0.92$$

$$B = b_1 \tan^2 \varphi + b_2 \tan \varphi + b_3$$

With different values for b for q or  $\gamma$ .

This solution is only valid if  $\varphi > 0$  and, if  $\tan\vartheta < \tan\varphi$ . It can be very useful if this empirical solution can be used. It is therefore investigated if this solution agrees with the conditions for the determined values. The vertical acceleration is unknown, as opposed to the corrections factors and the horizontal acceleration. Therefore, primarily the vertical acceleration is determined, then implemented to determine  $\vartheta$ , after which the conditions can and terms can be checked.

Determine  $k_v$ :

$$e_{qE}^s = \frac{N_{qE}^s}{N_q}$$

$$= (1 - A \frac{k_h}{1 - k_v} \cot\varphi)^{B_q} \sqrt{k_h^2 + (1 - k_v)^2}$$

With  $B_q = 0.4758$ ,  $k_h = 0.6$  and  $e_{qE}^s = 0.552$ . It follows that  $k_v = 0.00359$ .

Similarly,  $B_\gamma = 0.61527$ ,  $k_h = 0.6$  and  $e_{qE}^s = 0.461$ . It follows that  $k_v = 0.001165$

Determine  $\vartheta$ :

$$\vartheta_q = \arctan\left(\frac{k_h}{1 - k_v}\right) = 0.5420$$

$$\vartheta_\gamma = \arctan\left(\frac{k_h}{1 - k_v}\right) = 0.5409$$

Correction check:

$$\tan\vartheta < \tan\varphi$$

$$\tan\varphi = 0.7$$

$$\tan\vartheta_q = 0.601$$

$$\tan\vartheta_\gamma = 0.602$$

The results show that the empirical solution can be used for the seismic bearing capacity factor corrections.

## Inertia forces transmitted by superstructure

The earthquake bearing capacity factors as an effect of superstructure inertia forces are considered for three different load conditions. Shown below:

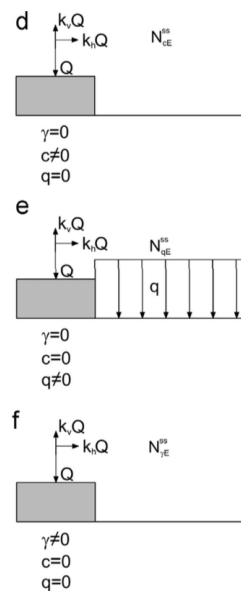

Figure 71: Superstructure inertial effects on soil (Cascone & Casablanca, 2016).

Each bearing capacity factor, for this inertia situation, is indicated as follows:

$$N_{cE}^{ss}, N_{qE}^{ss}, N_{\gamma E}^{ss}$$

The bearing capacity factors mentioned above, have been determined using the method of characteristics and finite element method by Cascone & Casablanca (2016). However, for the rough value for

$N_{\gamma E}^{SS}$  with  $\frac{\delta}{\phi} = 1$  and  $\gamma \neq 0$  only the finite element method was used.

Loading situation, D:  $N_{cE}^{SS}$

The surcharge  $q$  has been assumed to be zero, this earthquake bearing capacity factor  $N_{cE}^{SS}$  is then expressed as follows:

$$\begin{aligned}\gamma &= 0 \\ c &\neq 0 \\ q &= 0 \\ N_{cE}^{SS} &= 10.47\end{aligned}$$

Loading situation, E:  $N_{qE}^{SS}$

This earthquake bearing capacity factor  $N_{qE}^{SS}$  is then expressed as follows:

$$\begin{aligned}\gamma &= 0 \\ c &= 0 \\ q &\neq 0 \\ N_{qE}^{SS} &= 6.33\end{aligned}$$

Loading situation, C:  $N_{\gamma E}^{SS}$

This earthquake bearing capacity factor  $N_{\gamma E}^{SS}$  is then expressed as follows:

$$\begin{aligned}\gamma &= 0 \\ c &= 0 \\ q &\neq 0 \\ N_{\gamma E}^{SS} &= 2.03\end{aligned}$$

As can be seen, these seismic values for the bearing capacity factors are significantly smaller than the static bearing capacity factors. Subsequently a correction factor can be computed by comparing the static and seismic factors:

Correction factors for the seismic bearing capacity factors because of superstructure inertial effects:

$$e_{cE}^{SS} = \frac{N_{cE}^{SS}}{N_c} = 0.227$$

$$e_{qE}^{SS} = \frac{N_{qE}^{SS}}{N_q} = 0.190$$

$$e_{\gamma E}^{SS} = \frac{N_{\gamma E}^{SS}}{N_\gamma} = 0.0599$$

Like the soil inertia effect, also an empirical solution has been developed for the correction factors for  $c$ ,  $q$  and  $\gamma$ , from the computed values  $N_{cE}^{SS}$ ,  $N_{qE}^{SS}$ ,  $N_{\gamma E}^{SS}$ ,  $k_h$ ,  $k_v$  using the method of characteristics. This empirical solution is expressed as follows:

$$e_{jE}^{SS} = \frac{N_{jE}^{SS}}{N_j} = \left(1 - C \frac{k_h}{1 - k_v} \cot \phi\right)^D$$

With  $j = c, q$  or  $\gamma$ . And:

$C$  differs per load combination and  $D$  is expressed as follows:

$$D = d_1 \tan^2 \phi + d_2 \tan \phi + d_3$$

With different values for  $d$  for  $q$  or  $\gamma$ .

This solution is only valid, if  $\tan \vartheta < \tan \vartheta_{lim}$ . It can be very useful if this empirical solution can be used. It is therefore investigated if this solution agrees with the conditions for the determined values. The vertical acceleration is unknown, as opposed to the correction factors and the horizontal acceleration. Therefore, primarily the vertical acceleration is determined, then implemented to determine  $\vartheta$ , after which the conditions can and terms can be checked.



Determine  $k_{v,q}$ :

$$e_{qE}^{ss} = \frac{N_{qE}^{ss}}{N_q} = (1 - C_q \frac{k_h}{1 - k_v} \cot\varphi)^{D_q}$$

With  $C_q = 0.65$ ,  $D_q = 2.086$ ,  $k_h = 0.6$  and  $e_{qE}^s = 0.190$ . It follows that  $k_v = -0.015347$ .

Determine  $k_{v,c}$ :

$$e_{cE}^{ss} = \frac{N_{cE}^{ss}}{N_c} = (1 - C_c \frac{k_h}{1 - k_v} \cot\varphi)^{D_c}$$

With  $C_c = 0.4$ ,  $D_c = 3.601$ ,  $k_h = 0.6$  and  $e_{cE}^s = 0.227$ . It follows that  $k_v = -0.01612$ .

Determine  $k_{v,\gamma}$ :

$$e_{\gamma E}^{ss} = \frac{N_{\gamma E}^{ss}}{N_\gamma} = (1 - C_\gamma \frac{k_h}{1 - k_v} \cot\varphi)^{D_\gamma}$$

With  $C_\gamma = 0.9$ ,  $D_\gamma = 3.939$ ,  $k_h = 0.6$  and  $e_{\gamma E}^s = 0.0599$ . It follows that  $k_v = -0.4993$ .

Determine  $\vartheta$ :

$$\vartheta_q = \arctan\left(\frac{k_h}{1 - k_v}\right) = 0.5337$$

$$\vartheta_c = \arctan\left(\frac{k_h}{1 - k_v}\right) = 0.5334$$

$$\vartheta_\gamma = \arctan\left(\frac{k_h}{1 - k_v}\right) = 0.3806$$

Correction check:

$$\tan\vartheta < \tan\vartheta_{lim}$$

	$\tan\vartheta$	$\tan\vartheta_{lim}$
$q$	0.591	0.7
$c$	0.590	1.037
$\gamma$	0.4	0.7

Table 46: correction check empirical solution

The results (Table 46) show that the empirical solution can be used for the seismic bearing capacity factor corrections.

Determine seismic bearing capacity factors:

To account for the full effect of seismic activity on the bearing capacity, the correction coefficients must be investigated further. It can be seen from the correction factors that the effect of superstructure inertia appears to be significantly higher than the effect of soil inertia. It can be discussed, however, that this effect dampens, due to the Eigen frequencies of the building, due to its structure. It could also increase the effect, due to the same reasons. This can be investigated further. For simplicity reasons, the horizontal acceleration factors of both superstructure inertia effects and soil inertia effects, are assumed to have equal values. The correction factors both account for smaller values for the bearing capacity factors. It was discussed if superposition is in order, to account for the full seismic effect. Cascone & Casablanca (2016) have investigated the effect of superposition against separate effects and previously determined correction factors. They have found that superposition indicates a very good result to the full seismic effects as, a result of soil and superstructure inertia effects. The newly acquired bearing capacity factors are expressed as follows:

$$N_{cE} = N_c \cdot e_{cE}^s \cdot e_{cE}^{ss}$$

$$N_{qE} = N_q \cdot e_{qE}^s \cdot e_{qE}^{ss}$$

$$N_{\gamma E} = N_\gamma \cdot e_{\gamma E}^s \cdot e_{\gamma E}^{ss}$$

These seismic bearing capacity factors are then inserted into the static bearing capacity equation, to acquire the ultimate seismic bearing capacity. Furthermore, it must be stated that these seismic bearing capacity factors are determined, using a vertical acceleration equal to zero.

#### 10.2.4 Bearing Capacity factors

Primarily the bearing capacity factors must be calculated. However, these have already been determined in the previous chapters. For clarity reasons, they shall be repeated below:

$$N_c = 46.07$$

$$N_q = 33.26$$

$$N_\gamma = 45.18$$

The only bearing capacity factors which do not change under seismic conditions are the shape factors (Table 47). These have been previously determined, but the values are shown below (Table 47), for both load combinations:

Bearing capacity factor	M1
$s_q$	1.071
$s_c$	1.025
$s_\gamma$	0.963

Table 47: shape factors

#### 10.2.5 Overburden

The overburden also does not change when considering seismic conditions. The value has been previously determined, but is shown below:

$$d_{over} = 1 \text{ ft} = 0.3048 \text{ m}$$

### 10.2.6 Seismic Bearing load

The seismic bearing capacity factors have been determined. Subsequently, they can be implemented into the static bearing capacity equation, expressed as follows:

$$p = c \cdot s_c \cdot N_{cE} + q \cdot s_q \cdot N_{qE} + \frac{1}{2} \cdot \gamma \cdot B \cdot s_\gamma \cdot N_{\gamma E}$$

With:

$c$  = Cohesion [kPa]

$s_c, s_q, s_\gamma$  = Shape factors [-]

$N_{cE}, N_{qE}, N_{\gamma E}$  = Seismic bearing capacity factors [-]

$q$  = Overburden [kPa]

$\gamma$  = Unit weight soil [kN/m<sup>3</sup>]

$B$  = Width foundation [m]

Subsequently, the equation mentioned above is divided by the load combination factor for each combination separately. When the seismic bearing capacity is found, it is then measured with the actual load on the soil, to perform a unity check. It is then found if the soil will hold, or if the pilot building will fail under sliding. The seismic bearing capacity is found as follows:

Load combination: A1+M1+R1

$$p_1 = \frac{c \cdot s_c \cdot N_{cE} + q \cdot s_q \cdot N_{qE} + \frac{1}{2} \cdot \gamma \cdot B \cdot s_\gamma \cdot N_{\gamma E}}{R1}$$

$$= 275.96 \text{ kN}$$

Unity check:

$$U_1 = \frac{q_{v,max,1}}{p_1} = 0.159$$

Load combination: A2+M1+R2

$$p_2 = \frac{c \cdot s_c \cdot N_{cE} + q \cdot s_q \cdot N_{qE} + \frac{1}{2} \cdot \gamma \cdot B \cdot s_\gamma \cdot N_{\gamma E}}{R2}$$

$$= 197.11 \text{ kN}$$

Unity check:

$$U_1 = \frac{q_{v,max,2}}{p_2} = 0.175$$

Load combination: A1+M1+R3 = A1+M1+R1

Load combination: A2+M1+R3

$$p_3 = \frac{c \cdot s_c \cdot N_{cE} + q \cdot s_q \cdot N_{qE} + \frac{1}{2} \cdot \gamma \cdot B \cdot s_\gamma \cdot N_{\gamma E}}{R3}$$

$$= 275.96 \text{ kN}$$

Unity check:

$$U_1 = \frac{q_{v,max,2}}{p_3} = 0.125$$

From the unity checks, can be concluded that the foundation will not fail under sliding due to seismic activities, since the seismic bearing capacity is larger than the induced load, caused by the weight of the building. It can be discussed, however, whether the superstructure imposes the same horizontal acceleration on the soil. If the house resonates with different frequencies, the acceleration can become larger. The method of Cascone & Casablanca (2016) also does not consider the vertical acceleration effects. This can be investigated further.

## 10.3 Discussion of results and recommendations

### 10.3.1 Discussion of results

The results show that the foundation will hold the seismic activity for a PGA of 0.6g. The results, however, are solely determined by consulting a single source, Cascone & Casablanca (2016). This method assumes a vertical acceleration of zero. Which should be considered when determining the seismic activity and the reaction of the foundation, soil and building. Furthermore, the resonance of the superstructure is not taken into consideration. The horizontal acceleration is assumed to be the same as for the soil inertia effects. The building will vibrate due to the ground acceleration and will also oscillate with its own frequency, resulting either in resonance or damping. If resonance occurs, the superstructure inertia effects on the soil will increase, meaning an increase in acceleration forces. This effect is not considered, meaning that the foundation could still fail under sliding. Furthermore, the load combinations should be further investigated for seismic activity.

### 10.3.2 RECCOMENDATIONS:

As mentioned before the seismic bearing capacity is determined using a single source. It is therefore recommended to consult Eurocode 8, for further input and correction. It should also be investigated with the walls of the building, whether resonance will occur and what the superstructure inertia effects are.



An elderly woman with white hair, wearing a red knitted hat, a plaid jacket, and a green skirt with a brown patch, sits on a stone wall. She is looking towards the camera. To her left is a large haystack. In the background, there are mountains and a string of colorful prayer flags. The text 'PART IV. OPTIMISATION' is overlaid on the right side of the image.

PART IV. OPTIMISATION

# 11 Material optimisation

The optimisation phase includes technical recommendations and advices that should be followed during a future building construction and the interventions that must be done on the current solution already built in Ratankot to make it earthquake safe. To fit these purposes, actual structural performance and materials properties that have been used to build the house have been analysed. It is then possible determining the required structural cross sections of the structural elements, the necessary composition and conformation of the used materials to achieve a certain on site performance, the strength that joints should ensure and what and how certain interventions can improve these aspects.

## Required properties of materials

To achieve a certain structural performance of the house, materials must have specific characteristics. Considering the cultural and intellectual situation of the village where the house has been built and after the done analysis on the actual properties of the materials that have been used, some recommendations can be said for future materials applications about the composition, mixing, curing and finishing processes that they require.

## 11.1 Concrete

Concrete is generally made directly on the site of construction. The mix design one uses, as well as curing processes followed and environmental conditions, highly influence the actual properties of the material. Because this material is used for structural purposes, enough attention must be put into these construction phases not to compromise the actual on site properties. Recommendations that must be followed by workers about the needed components types for the mix design, as well as their required amount and the curing processes that they need, will be explicated. Furthermore, a comparison between what are the actual properties of the used concrete and those that should be needed to fit our structural purpose will be made, ending up to interventions that could be done to fill the eventual gap between them.



## 11.2 Bamboo

As a natural material, bamboo's properties change situation by situation, highly depending on several factors as ages, treatment processes and thickness of the structural elements. To make structural calculations, average assumptions about its properties will be considered, and they will come out after onsite inspections, analysis and technical consultancy with local associations that already build with bamboo as well as consulting literature and researches developed about this topic. In the case that the used material will not be reliable, the feasibility of processes that could improve the material properties will be analysed.

### 11.2.1 Optimisation of bamboo

To make the use of bamboo for houses in rural areas more feasible, optimisation is needed. For the pilot house, treated bamboo has been bought of the bamboo supplier Abari. On this matter, the bamboo needed to be transported from the south of Nepal toward Ratankot. The costs of the bamboo with transportation came out around \$1000,- [SSN4]. This is around 20% of the total costs of the house. To reduce the costs for the roof, local bamboo can be used. The bamboo first need to be treated before use and therefore ways of treatment will be discussed. Also, options will be given if the bamboo is not locally available and the optimization possibilities between the connections of bamboo with bamboo and bamboo with the concrete are investigated. For the pilot house no grants are given because the building technique is not yet approved by the VDC or DUDBC. When the inhabitants of Nepal want to receive grants when copying the pilot house, bamboo needs to be approved first. This part will be

discussed in social acceptance and approval.

### Local bamboo vs companies

Bambusa Balcooa is growing on certain places in Nepal (Figure 72: the places where bambusa balcooa is growing Figure 72). On the site visit in Ratankot in the Sindhupalchowk area is noticed that on just a few places the villagers are planting bamboo for structural use. Bamboo will grow best near a stream of water and of that kind of places Ratankot have plenty (Appendix, interview Karma). If the villagers will be convinced of using bamboo more often in their households, more bamboo is needed. They can buy it from certain companies or grow it themselves. The use of local bamboo plantation will make the village less dependent on outside sources and will cut down the high transportation cost (SSN4, 2017). The bamboo that has been used for the pilot house was expensive. Definitely comparing it with the use of local bamboo. Untreated bamboo out of the hills from Ratankot can be bought for approximately 100 NPR [Shaym Lama]. If you take treatment costs into account, the price of one bamboo culm will raise with 100 NPR [Habitat]. This is still about five times cheaper than the bamboo bought from 'Abari' (excl. transportation cost). Also, the circular economy of the village gets stimulated.

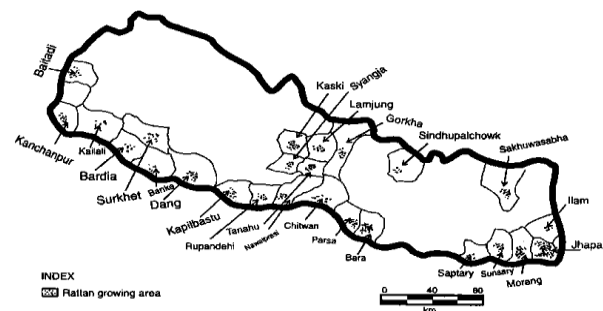

Figure 72: the places where bambusa balcooa is growing

When every household of Ratankot (250 households) want to build their roof out of bamboo, 60\*250 bamboos are needed. This amount is not available directly so a solution is needed. At this moment, there are around 80 plants of bamboo with an age of 2.5 years. In two years, when the bamboo is mature it can provide enough bamboo for one or two roofs. SSN4 suggested to start a bamboo nursery in Ratankot. This would be a great opportunity to gain more money and be less independent of companies. There are a few problems though.

- The people need roofs right now
- The bamboo grown by the people need to be sold
- Which land will be used for the plantation?
- Who is going to be in charge?
- What will happen with the bamboo if the villages around Ratankot doesn't need Bamboo anymore?

On this matter, an interview with Karma Lama was necessary (Appendix interview Karma) The outcome of the interview was that in his opinion the bamboo price is too low to sell it with profit. Also, there is a huge problem if the bamboo is not harvested in time. After 7-10 years the bamboo gets so strong and heavy that only men power will take a lot of effort to cut it. But a smaller plantation, only for the village itself could be a good solution. For the problem that the bamboo is needed right now Habitat came up with a solution. They are not yet selling their bamboo to villages outside of their districts, but are willing to sell Ratankot bamboo with the price of 250 NPR for one treated bamboo culm. At the site visit in Pipaltar it has been noticed that the Bamboo Habitat is using is of good quality and specially is straight compared with the bamboo of Abari.

### 11.2.2 Local treatment of bamboo

There are different ways of treating bamboo with different economic and environmental aspects, traditional/non-chemical methods and Chemical treatment methods (SSN4, 2017). Local treatment needs to be feasible (easy in use, cheap and portable), reliable (fast and efficient treatment method to solve the termite and beetle problem) and environmentally friendly. On this matter treatment with Water leaching, Boric Acid Borax, Copper Chrome Arsenic (CCA) and Copper Chrome Boron (CCB) will be discussed. The main resources for this research are a paper of abari (Adhikary, n.d.) and INBAR's website. (Inbar, 2015)

#### Water Leaching [SSN4]

This is the most vernacular and traditional way of treating bamboo culms. All that is need is running water, ropes and time. The bamboo culms are placed in a stream and the flowing water is used to flush away starch from bamboo culms. The bamboo needs to be submerged under water for three weeks. After this it has to dry horizontally for three till four weeks.

Advantages:

- Safe non-toxic approach
- Economical

Limitations:

- Time consuming
- Lot of effort required
- Limited production
- Transportation to water can be difficult

## Borax and boric acid

Curing bamboo with borax and boric acid is the most popular bamboo preservation method around the world because it is effective and more environmentally friendly than other wood preservatives [Guadabamboo.com]. Borax or sodium borate is a soft, colourless, powdery mineral that dissolves easily in water. It is a natural insect repellent and preservative. In Nepal, it is common to use Borax to treat bamboo. The ratio is for indoor use of bamboo Borax: Borax Acid: water is approximately 1.5:1:100. So 1.5 kg of borax, 1 kg of borax acid in 100 litres of water. For outdoor use the ratio becomes 1:1:30.

### Advantages:

- Insect repellent
- Simple technique
- Cost friendly

### Limitations:

- Equipment is needed
- Pressure is needed
- Treatment needs knowledge
- Protection against UV and rain is required

## Copper Chrome Arsenic (CCA)

Commonly used as wood preservative. Used for timber treatment for almost a century. It is recognizable for its green tints in the treated timber. Copper act as bactericide, arsenic as insecticide and chrome is used to mix the arsenic and copper and gives UV protection as well. CCA is a heavy duty broad spectrum chemical bamboo preservative (Farm, n.d.).

### Advantages:

- Bamboo can last for more than 50 years
- Very effective for outdoor use

### Limitations:

- Safety cloths are necessary
- very toxic
- often prohibited
- Equipment is needed
- Pressure is needed
- Treatment needs knowledge

## Copper Chrome Boron (CCB)

CCB is a broad spectrum chemical bamboo preservative and a good alternative to CCA, but less effective with a lower degree of fixation, because of the boron component.

### Advantages:

- Less toxic compared to CCA
- Effective for outdoor use

### Limitations:

- Brush the bamboo every two years with a coating
- Safety cloths are necessary
- toxic
- Equipment is needed
- Pressure is needed
- Treatment needs knowledge

v1.0	Water Leaching	Boric Acid Borax	CCA	CCB
Easy in use	++	++	-+	+
Cost friendly	++	+	-+	-+
Portable	+	++	++	++
Reliable	-+	++	++	+
Environmentally friendly	++	+	--	-+
Time consuming	--	+	-+	-+
	Ok for Ratankot	Very good for Ratankot	Not good for Ratankot	Not good for Ratankot

*Table 48: comparison between treatment methods*

Because the use of Borax is easy and portable, this treatment is chosen to be used for a case study (). Still, it is important to

keep in mind that the treated bamboo needs to be protected for the weather.

### 11.2.3 Local treatment using Boric Acid Borax in Ratankot – case study using gravity

Treatment of bamboo with borax needs a certain pressure to “push” out the starch and replace with conservative. The pressure that is needed for treating lays around 25 psi. The higher the pressure, the less time is needed to make the preservative reach every part of the bamboo culm. If the pressure is too high, the chance of leakage will rise. The preservative needs to be pushed through the bamboo between 1 - 3 hours. To gain pressure, two possibilities are discussed. The most common method is to use a pressure cylinders with a mechanism that can increase pressure (hand pump or electric compressor). For rural areas, this is maybe not the best solution. All the equipment together cost around \$500,- (Farm, n.d.). This price can be reduced by using second hand devices and using hand pumps instead of expensive compressors. A better solution to gain pressure is the use of gravity. The setup and procedure for both methods are nearly the same. In the case of gravity, the tank with preservative needs to be placed higher than the bamboo and the pressurizing devices are no longer needed. From the comparisons, results show that the treating method using borax and boric acid in combination with gravity is a more feasible and cost friendly method, a case study has been done on this matter.

The study consists of feasibility and reliability of the method and local tests executed. In this case, the tests are done in Ratankot because SSN has got good relationships in the village. Treatment on site is new for the villages as it is for SSN. Because of this matter, the people in the village need to be trained.

#### Feasibility

The price of the machine lays around \$100,- [Appendix cost botchery machine] and for the feasibility, it must be as low as possible. Because a lot of small parts are needed, a much lower price is hard to accomplish. Because it is new for the people in the villages the method needs to be simple. For this method, height difference in the village is needed so this is an important limitation. The preservative cost 2500 rupee (25 USD) per 25 litres. With 25 litres, 25 bamboo culms can be treated.

#### Reliability

As mentioned before, borax is a good solution for villages in rural areas. Tests by Inbar and “Abari” showed that it is a simple method and that the bamboo culms can last for more than 25 years.

#### Method

The method consists of a pressurised boucherie machine. The pressure is gained by using gravity. The pressure pushes the preservative through four connections to four different bamboo culms. The preservative is mixed in a gallon and flows through a hose towards the connections. To manufacture the machine, separate parts are bought in local market places. The costs can be found in the Appendix (Figure 113). The parts needed can be found in the report of HBC, Bamboo in Nepal (HBC, 2013). The bamboo need to be harvested in the dry season and cut just above the first node. To cut the bamboo always use a sharp saw or tool to avoid damage to the culm.

## Required height

$$P = \rho * g * \Delta h$$

$P$  = pressure in pa

$\rho$  = density in kg/m<sup>3</sup> of preservative (~1010kg/m<sup>3</sup>)

- Borax 1730 kg/m<sup>3</sup>
- Borax acid 1435 kg/m<sup>3</sup>
- Water 1000 kg/m<sup>3</sup>

With a ratio of 1:1.5:100 the density of the preservative becomes 1011.43 kg/m<sup>3</sup>.

$$g = 9.81 \text{ m/s}^2$$

$\Delta h$  = absolute height difference between cylinder and bamboo

To gain 25 psi (172 368.932 pa) a height difference of 17.5m is needed.

A short explanation of the procedure:

- 1) Fill gallon with the mixture of water, borax and borax acid
- 2) Connect the bamboo culms 17.5 meter below (airtight)
- 3) Let the preservative flow to the culms by opening the valves
- 4) Open the air outlet for a split second to let the air out
- 5) Let the preservative flow through bamboo
- 6) Wait between 2-3 hours to treat the bamboo
- 7) Test if the bamboo is completely treated
- 8) Disconnect hoses (Collect remaining preservative)
- 9) Store the bamboo horizontally in a dry area for 3-5 weeks

This procedure needs to be explained to the people in the villages. The best way to train people in Nepal is showing them how to do it, they can copy everything [interview with Karma on the Roof]. On 4/4/2017 the training

found place. In the appendix (Figure 116) photos can be found of this training.

## Social acceptance and approval

In earlier stages of the project it was doubted that the people in Nepal would accept bamboo as a building material, but the villagers of Ratankot are interested in Bamboo [Interview villagers Ratankot]. They indicated that they are even interested in a house completely made out of bamboo. These are big changes for the social acceptance of bamboo. If people want to build houses out of bamboo, it is important that the grants can be rewarded. Therefore, the material needs to be added to the NBC as a construction material. This will not happen in the coming years [Government]. For the construction part of the framework of a house, the government must be sure that the structural behaviour is known. With bamboo that is almost impossible, every bamboo culm is different and an overarching judgement is hard to accomplish. Nevertheless, bamboo is added to the NBC as a material for a roof, floor etc.

## Conclusions on local bamboo treatment

The acceptance to build with bamboo in rural villages in Nepal is growing. To build with local bamboo, treatment is needed. The most feasible method is to use a boucherie machine that is pressurized using gravity. The machine is cheap, portable, simple and works properly. The people in the village where able to treat the bamboo by themselves after 2 hours training. If a compressor is used instead of gravity, the time of treatment will be reduced. However, the compressor will take more maintenance, money and it need to be transported with a truck.



## Recommendations

To lower the costs of treating bamboo with borax and boric acid, the preservative could be bought in bigger portions and it is hard to say something about the durability of the machine. Also, it would be helpful if the training “how to build the machine” and “how to use the machine ”can be downloaded by the people in rural areas. The total costs of the material to build the bucherie machine is 7227,NPR or 65.54 EUR. The total costs of the borax and boric acid for the preservative is 2992,- NPR or 26.72 EUR per 2 kg.

## 11.3 Steel

Steel has structural properties depending on the type of steel itself that has been used. Knowing that, and because the construction happened a few months ago, no particular investigations will be needed to determine the actual properties of the material. This will be available consulting documents made by previous teams. Furthermore, environmental conditions can be said satisfactory or at least no dangerous for steel elements. Only the effects of particular components of the concrete that can compromise steel properties and durability.

## 11.4 CSEB bricks

### 11.4.1 Optimisation of CSEB bricks

The need for CSEB in Nepal is growing because it is reliable and easy in use. Materials that can be fabricated on site, have got a big advantage in Nepal because the transportation of materials is expensive. Another problem with transportation is the fact that the roads are bad and bricks can brake by vibrations. The use of CSEB is feasible in a village when sand, cement and soil is available. The availability of these materials depends from the access to the village and if there is a river nearby that can provide sand. The blocks are often made by villagers who are trained by a NGO. Still, a lot of blocks that are produced do not have the correct quality. This can be a consequence from a lack of knowledge about the importance of the right ratio of the composition. Therefore, a quality check should be done after a constant number of blocks. In cooperation with Build Up Nepal, a plan has been set up.

The right quality of the blocks used for households and schools is of great importance. Every block is fabricated by hand so the quality varies a lot. This variation is not a concern if it stays between a certain range. Build up Nepal set their focus that every block has got a compressive strength of at least 5 MPa after 28 days of treatment. This strength can be measured with a compressive strength machine in for example a laboratory. But, what happens if the block doesn't contain this strength? This probably means that the whole batch is not of the right quality. In 28 days, the village is capable of making approximately 10000 blocks and if they all need to be destroyed, they lose money. Therefore, it is desired to check the quality of the blocks in a much earlier stage of the production. For this reason, SSN5 have set up a quality test in

cooperation with Build Up Nepal. The quality test contains the possibility to check the compressive strength on site after 2 and 5 days of treatment without using expensive and heavy equipment.

### Quality check

The quality test is build up in two phases. The first phase is to find a correlation between the compressive strength of the blocks after different days of treatment. With this correlation, the villagers can test their blocks made on site during phase two and directly know if the block after 28 days will be strong enough. The first phase will be executed by Build Up Nepal. The results can be used by everyone that builds with the specific interlocking CSEB. The second phase can be executed by villagers to test their batches.

#### 1) Phase one

To discover a correct correlation between the compressive strength after 2 and 28 days, 200 blocks will be made out of different compositions. The different types of compositions are based on literature and the practical knowledge of Build Up Nepal. In the appendix (Figure 115) the scheme of the first phase can be found. Every composition will be tested after 2, 5, 7, 14 and 21 days. The different ways of testing are: early load bearing test, drop test and compressive strength test.

- The early load bearing test will be executed by adding load from the top on the block and research how much weight it can bear. The load that can be used are blocks that already have been treated for 21 days. These tests will be done after two and five days.
- The drop test will be executed by dropping the block from a certain height. If the block breaks, the “break

height” is achieved. This test will be done after five and seven days.

- Compressive strength test will be executed with the use of a compressive strength test machine. Build up Nepal possesses a certain machine. This test will be done after five, seven, fourteen and twenty-one days.

To find a correct correlation it is necessary to test multiple compositions. After these test, a correlation can be found between the early load bearing test and the final compressive strength of the CSEB. This correlation can be used in phase two.

#### 2) Composition

The blocks that are produced on site, will always differ of composition. Because of that matter, the compositions that will be used in phase one will vary as well. For the last 18 months Build up Nepal used a composition of 10% cement and the soil that consists 50% sand, 15% silt, 15% and 20% clay as previous discussed. More percentage of sand means a higher compressive strength of the block (Ipinge, 2012). In the rapport of “from the ground up” stated that:

*“The ideal Mixing ratio of HI CSEB is 12% cement, 16% clay, and 72% sandy soil. However, the soil cannot be top soil or organic soil, it must be loose sandy soil. It is found that it is best to use around 50% sand and 22% silt in the soil mixture. The linear expansion and water absorption of the bricks increase with clay content so it is best to keep it under 20% for durability”.* (FromTheGroundUp, 2016)

In consultation with Build Up Nepal, twelve compositions have been chosen to research. Because cement, clay and sand has got the most influence on the compressive strength,

these will vary (Appendix table CSEB test). The mixture with 5% cement will definitely fail faster than the compositions with 8%+ cement, but this is also a required result of the experiment. The villagers will have a wider range where they can check the strength of their blocks.

### 3) Phase two

The correlation between the different testing methods and the final compressive strength of the CSEB can be used on site. The workers that are producing the blocks can easily check the batch on quality by applying tests after two days on the described “early load bearing test”. A double check can be done after the fifth day by dropping the brick from a certain height. It will give an assumption about the final compressive strength after 28 days.

*“In the past, hollow concrete blocks showed a big potential as a good building material. It is very cheap and strong if it’s produced correctly. However, this material is also produced by hand and showed during the earthquake that it did not passed the right quality. After this, the people didn’t believe that the hollow concrete blocks where a good building material. This could happen to CSEB as well if the quality is not inspected and protected.” [Bjorn Build up Nepal]*

### Remarks

To produce CSEB in a village, there are three main restrictions. The right soil needs to be available, a road needs to be in a range with a maximum of two hours walking and the most important part is that the villagers must willing to work with the CSEB. To inspect the site on the available soil, a few practical tests can be done.

*Visual Test - Soil below the topsoil layer is obtained. Very sandy soils or very clayey soils are not suitable for block*

*production. Very clayey soils are usually visible by the presence of a large number of cracks in the soil. Very sandy soils are usually visible by the lack of plasticity in the given soil.*

*The Jar Test - A jar is filled with a third soil and two thirds water. The jar is then shaken vigorously for 5 minutes and left to settle for 24 hours. The soil will settle in gradations, sand, clay and silt. Ideally clay should be between 15 and 35%.*

*Shrinkage Test - A rectangular shrinkage box is filled with wetted soil and left to dry in the sun for five days. Shrinkage is measured with a ruler. ideally shrinkage should be between 20 – 40mm.*

*Drop Test - This test is required to check the moisture in the mix for block production. The soil-cement-water mixture is squeezed in one hand, the resulting ball is dropped from waist level, if the ball shatters into many pieces it is too wet, if ball breaks into five to six lumps then right content, if ball does not break then the mix is too dry. (Ipinge, 2012)*

### Recommendations

In case of the house build by SSN4, the CSEB is part of the loadbearing structure. Therefore, it is important that the blocks keep their strength and properties. According this they need to be protected against the weather. Therefore, ways of treatment are needed and need to be investigated more.

In case of an earthquake the walls of a building are heavily exposed to lateral forces. This could result that the walls will fail by the shear. With that in mind it is important to understand the behaviour of a wall and the maximal shear force that the wall can bear. In cooperation with Build Up Nepal, the shear strength of the CSEB is determined. In the heavy laboratory of the Pulchowk

campus, machines were available to test a build a wall of 1m x 1m of blocks filled with cement mortar. Unfortunately, the test was not executed when this report was made, so this is an important property to find out. The publication of Chalmers University of Technology is a reference to gain more knowledge of CSEB in earthquake situations. (Mellagard, 2016)

## 12 Structural optimization

Structural interventions could be needed to improve the actual performance of the house. This is even based on the actual properties of the materials that are available for being used in the construction processes. The actual structural response of the building gives advices about what must be improved to fit the earthquake safety purpose, both under static and dynamical conditions. Under static loads, improvements include the re-design of the required cross sections of the structural elements to bear loads effectively, considering which properties of materials can be feasibly achieved. Depending on the actual structural performance of the house, the impact of additional structures (if necessary) can be analysed to fit the main structural purpose. Under dynamic conditions, hand-made calculations will be developed in order to have an overview about the structural mechanism of the structure when an earthquake happens. This phase will be the set up for more advanced calculations that can be developed further by PhD or master students for their specific thesis linked to this topic. However, a structural 3D model will be analysed with FEM software to have a first digital idea

about the behaviour of the structure under dynamic loads.

### 12.1 Joints

The roof is made out of bamboo and is constructed next to the house. When the roof was completed, it was lift onto the walls with manpower. The connection between the roof and the walls are rebar's which have been bent over the bamboo. If there is a heavy storm, the wind can lift the roof and even blow it of the walls. Therefore, a different approach is needed in the future to make sure that the roof will be connected better.

An option is to cast steel connection points into the upper concrete band. The roof can then be constructed directly on top of the walls and connected in a proper way.

Also, the weight of the roof is not divided equally over the walls. Because the roof is constructed with culms on top of each other instead of against each other, two of the five walls don't bear loads. A better roof plan and connections between the culms are needed to prevent that the roof is carried just by three walls. Also, the roof can be optimized with respect to the weight. In the model made with Matrix Frame, culms can be found that are not necessary for the strength of the roof. These can be removed to make the roof lighter. Still, under the edges of the plates that are on the bamboo culms, needs to be attachment points to make sure that the plates are connected to the structure properly.

In the chapter about bamboo is stated that the strength of the bamboo in the nodes is 60% less. In the roof of the model house, some joints are connected through the nodes so this needs to change in the future as well. The carpenters need to have this

knowledge before they are constructing the roof.

### 12.1.1 SOIL PARAMETERS

#### Soil parameters:

The construction site was previously farmland. Its soil is not necessarily fit construction ground. From the calculations, it seems that the soil is fine for construction. However, it can be discussed as to how accurate the assumed soil parameters are. It is therefore, firstly recommended to investigate the soil parameters in more depth. Based on the outcome of this analysis, it can be wise to either find a more suitable construction site or to reinforce the current construction site. Namely, when a is built very loose sands or sensitive clays the soil, compaction under seismic conditions may occur, followed by large inequalities in the structure (Arya, 2013).

#### Near a wall and on stepped land:

Even though before construction and designing of the pilot house, general rules of earthquake safe building were discussed and applied, it is still build on a sloped site. Moreover, the slope is not reinforced by a retaining wall and soil properties have been assumed, leading to insecurities regarding the slope stability (Arya, 2013). It should therefore be reinforced with a retaining wall. Furthermore, the house is also built next to a slope, meaning when this slope fails, the house will be exposed to large forces. This slope should therefore, also be reinforced by retaining walls.

#### Still not fully flat site:

The site in Ratankot has only been flattened for the plot of the pilot house. Around the plot, still little hills and unflatten ground is found. This could lead to unevenly distributed accumulation of water, which could have negative eroding impact of the site. Therefore, the site should be flattened in the future.

#### Fluctuating saturation / Drained/undrained

Nepal suffers of large fluctuations in dry and wet weather, due to monsoon seasons. This leads to large water runoff, especially with the sloped site. At the site, no attention was paid to these large volumes of rain water runoff. This could lead to erosion of the slopes and ultimately to failure. Therefore, drainage, channel and rainwater runoff systems must be implemented.

### 12.1.2 STATIC CALCS FOUNDATION

#### Foundation columns not necessary:

The superstructure is build using a wall bearing construction. The columns of the structure, carry solely their own weight. The foundation contains lager and deeper footings below the columns. This is over dimensioned, since the walls bear the load and transmit these to the strips below. In case a new model is designed, thorough attention must be paid to these over dimensioned elements.

#### Over dimensioned

From the bearing capacity unity checks, it can be concluded that the foundation is over dimensioned since the unity checks show a significant large difference between the induced load and the bearable load. In case



a new model is designed, thorough attention must be paid to these over dimensioned elements.

### 12.1.3 PSEUDO STATIC CALCS FOUNDATION

#### Foundation dimensions:

Even though the results show that the foundation will hold for a PGA of 0.6. It could very well be that the next earthquake will induce a larger PGA value. In this case, the house may not hold. By increasing the width of the strip foundation, up to about 1 to 1.5 meters, this can help make the difference. By shifting the width, the seismic bearing capacity will increase with a factor of 5 to 10.

#### Roughness foundation:

Even though the roughness of the foundation is assumed to be high, it could very well be quite lower than expected. This could mean that instead of leaning towards the perfectly rough side it could also be a little smoother. This has a significant impact on the seismic bearing capacity factors. For smoother foundations, the seismic bearing

capacity factors are smaller as well, meaning less bearing capacity and more chance of failure. It should therefore either be further investigated or the foundation should be built with known materials.

## 12.2 General recommendations

General recommendations are necessary from the one hand to ensure that the structural lacks the house already made will be filled and on the other hand that future construction will not repeat design mistakes or lacks that have already been made. Building in this rural context, influenced by low building knowledge and no possible ways to check the actual on site construction makes both design and building phases requiring more attention. However, general recommendations that consider this cultural situation will be made, that will not need technical or scientific knowledge to be followed. Of course, these can change situation by situation depending on the specific area where houses can be built, but still these recommendations, for example the location of the buildings, can be extended for different cases.

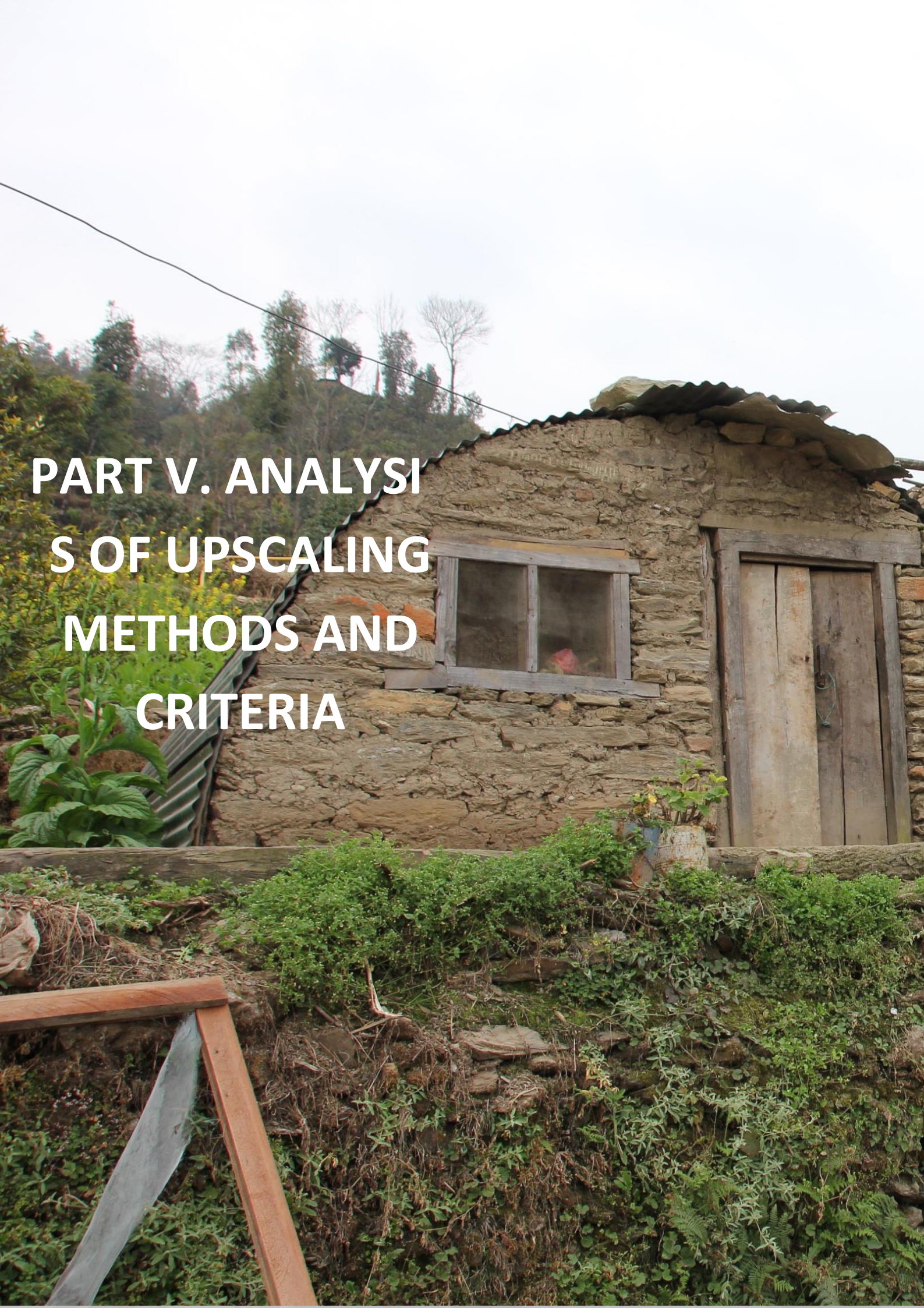

A photograph of a rustic, single-story building constructed from rough-hewn stone and mud. The building features a corrugated metal roof, a simple wooden door with a metal handle, and a window with a wooden frame. The structure is built on a steep, vegetated hillside. In the foreground, there is a wooden frame structure, possibly a fence or a support for a structure. The background shows a hillside with various trees and a clear sky.

**PART V. ANALYSIS  
S OF UPSCALING  
METHODS AND  
CRITERIA**



# 13 Stakeholder Analysis

In addition to the technical aspects of the house, the context in which building is done in Nepal has to be analysed. The following chapters consist of an analysis of this

In order to have a clear view of all the actors involved in the project at this moment, two years after the earthquake, a stakeholder analysis is carried out. Until team 4, the scope of SSN was on the case study Ratankot. In order to be able to make a long-term plan for upscaling, zooming out is essential. Which stakeholders have been helpful in the past? How are the relationships between them and SSN? Can they also contribute in the long-term? Who should SSN collaborate with to achieve the final goal? And where does it place Ratankot, which is initially a case study? Therefore, the aim of the stakeholder analysis is to determine how stakeholders are related to SSN and what role they play.

The base of the stakeholder analysis of team one is used. The stakeholder analysis determines and describes their power, interest, attitude, goal, problem perception and whom they can collaborate with and who they might be in conflict with. This is done through literature research and interviews with different actors in Nepal, which can be found in Appendix II.A It is done as thoroughly as possible and up to date, however, the stakeholder analysis is done for SSN and therefore contains important stakeholders with regard to the project and its context. Furthermore, names of government institutions are changing

relatively often. The second aspect that has to be considered is the vast number of organisations that are active in Nepal. There are approximately 6,000 NGOs recognised by the Government. It is estimated that more than 15,000 NGOs in Nepal are working in various sectors. (Jones, Owen, Manyena & Aryal, 2014) The latest figure available suggests nearly 40,000 NGOs are registered with the Social Welfare Council and 189 INGOs representing 25 countries (The Himalayan Times, 2014), therefore an important part of conducting the stakeholder analysis was including organisations that are currently related to the project, or could be interesting in the future, but not those that are not of importance to the project.

This extensive stakeholder analysis can be found in Appendix II.A. After the stakeholder analysis, a power/interest matrix was drawn up followed by a Murray Webster & Simon graphic which shows the power/ interest/ attitude for each actor, which helps to define their relationship with SSN in the future. To show the relations between the actors, a network analysis is made. This is investigated through interviews, and shows important exchange of knowledge, funding and materials between stakeholders. The network analysis is done to give an oversight of current links between stakeholders in Nepal and to help define important contacts and paths to achieve goals and the role of SSN in a complex situation.

## 13.1 Types of stakeholders

The type of stakeholders has been split up as follows:

- Governmental organizations
- Platform organisations
- Inter-governmental organisations (IGO)
- International non-governmental organisations (INGO)
- Non-governmental organisations (NGO)
- Research/knowledge organisations
- Locals

In the tables below (Table 49, Table 50, Table 51, Table 52, Table 53, Table 54 and Table 55) the stakeholders are determined, described and split up into types to get a clear overview of all the stakeholders involved.

GOVERNMENT	ACR	DESCRIPTION
General Government of Nepal	GoN	Government on national level, responsible for legislation CL-PIU.
Central Level Project Implementation Unit	CL-PIU	Central level authority, responsible for legislation CL-PIU, organization where designs are handed in for approval on national level
District Level Project Implementation Unit	DL-PIU	Is established under CL-PIU in the 14 most affected districts. Responsible for legislation DL-PIU, organization where designs are handed in for approval on district level and responsible for technical assistance
Village Development Committees	VDC*	Responsible for municipality level
Department of Urban Development & Building Construction	DUDBC*	Organizing large scale projects to rebuild Nepal. Besides the earthquake situation also other interests on urban developments and construction.
National Reconstruction Authority	NRA	Organization that is set up after the earthquake in 2015, responsible for leading and managing recovery and the reconstruction programme in a sustainable and planned manner. NRA requires the functional autonomy and institutional capacity to implement and coordinate the recovery programme expeditiously.
National Commission Planning	NPC*	Apex advisory body of the government on vision, planning and policies. Assesses resource needs, identifies sources of funding, and allocates budget for socio-economic development. Has developed a long-term development strategy for Nepal—Envisioning Nepal 2030—

Table 49: Stakeholder description: Government

<b>RESEARCH/KNOWLEDGE INSTITUTES</b>	<b>ACR</b>	<b>DESCRIPTION</b>
TU Delft	TUD	Educate; knowledge and research institute focused on engineering, based in The Netherlands
Tribhuvan University		Educate; knowledge/research institute focused on engineering, based in Nepal

*Table 50: Stakeholder description: Research/knowledge institutes*

<b>INFORMATION PLATFORMS</b>	<b>ACR</b>	<b>DESCRIPTION</b>
Housing Recovery and Reconstruction Platform - Nepal	HRRP	HRRP is a platform for coordination, strategic planning and technical guidance to agencies involved in recovery and reconstruction and to support the Government of Nepal in coordinating the national reconstruction programme.
Social Welfare Council	SWC	All NGOs have to be registered under this organisation

*Table 51: Stakeholder description: Information platforms*

<b>IGO</b>	<b>ACR</b>	<b>DESCRIPTION</b>
International Organization for Migration (UN Migration Agency)	IOM	Leading inter-governmental organisation in the field of migration

*Table 52: Stakeholder description: IGO*

INGOs	ACR	DESCRIPTION
Architecture sans Frontieres	ASF	Aiming to contribute to the sustainable development of disadvantaged communities in Nepal by sharing technical and scientific expertise, thereby helping communities improve the quality of their lives
UN-Habitat		UN-Habitat envisions well-planned, well-governed, and efficient cities and other human settlements, with adequate housing, infrastructure, and universal access to employment and basic services such as water, energy, and sanitation.
UNICEF		UNICEF in Nepal mainly focuses in the 15 lowest performing districts of Nepal but our impact is nationwide especially with our advocacy work with the Government of Nepal in developing legislations, plans, budgets, coordination and monitoring mechanisms that enable the survival, development, protection and participation of children, adolescents and women.
Nepal Red Cross Society	NRCS	Nepal Red Cross Society shall remain an efficient, self-sustainable, and independent humanitarian organization committed to provide immediate relief to human suffering and reduce vulnerability, under the Fundamental Principles of the Red Cross, through its network of Red Cross workers throughout the country working closely with communities and governmental and non-governmental organizations in a democratic, transparent and participatory way
Habitat for Humanity		Non-governmental organisation who provides locals with decent housing.

Table 53: Stakeholder description: INGO

NGOs	ACR	DESCRIPTION
NGO Federation of Nepal		Umbrella organization for NGOs in the aftermath of democratic political change and establishment of multiparliamentary system.
National Society for Earthquake Technology	NSET*	Nepali non-governmental organisation working on reducing earthquake risk and increasing earthquake preparedness in Nepal as well as other earthquake-prone countries.
Nepal Centre Disaster Management	NCDM	Helps to effectively mitigate the impact of disasters in the country. The Centre is registered in the Kathmandu District Administration Office, Government of Nepal. NCDM is also registered under the Social Welfare Council, Nepal. Several projects regarding disaster risk management concerning earthquakes, flooding, drought and avalanches.
Support4Nepal		Works on improving living standards in Ratankot and collects funds from Belgium
Build Up Nepal		Works as an implementation partner. Empowering local people using local materials, providing machines and training for rural communities, teaching them to make CSEB and rebuild their own village together with INGOs and NGOs.

Table 54: Stakeholder description: NGOs

LOCALS	ACR	DESCRIPTION
Representatives Ratankot		Karma Lama and Shyam Lama who have had a large role in the development of Ratankot. Shyam regarding development of Ratankot and Karma regarding funding, knowledge and partners.
Inhabitants Ratankot		700 people living in Ratankot where houses are destroyed
Workers Ratankot		People who helped with building the pilot house in Ratankot, both from surrounding villages and Ratankot itself.
Inhabitants surrounding villages of Ratankot		7 areas of Ratankot.
Inhabitants villages in other rural areas		To be informed

*Table 55: Stakeholder description: Locals*



## 13.2 Key stakeholders

Key stakeholders are determined below, as some stakeholders, such as the government, have more power than others in general or more interest in SSN than others. In addition, since team one did a brief analysis, the organisational structure changed. The shelter cluster became HRRP, NSET only became active after the earthquake and NRA was set up. The structure and key stakeholders have been determined through interviews (Appendix II.B)

### 13.2.2 Organisation of the Government of Nepal with affected actors

The following figure shows the organisational structure of the government of Nepal and the organisations that fall under it. It shows the two ministries that play a large role in the reconstruction but that were in place before the earthquake, the NRA that was formed after the earthquake and the departments and units that they are responsible for.

#### 13.2.1 Governmental organisations concerning legislation

The governmental organisations have the highest power of all stakeholders, as they are responsible for the legislation and funding of housing. The stakeholders of the government concerning legislation fall under the Government of Nepal. A clear overview is presented below (Figure 73).

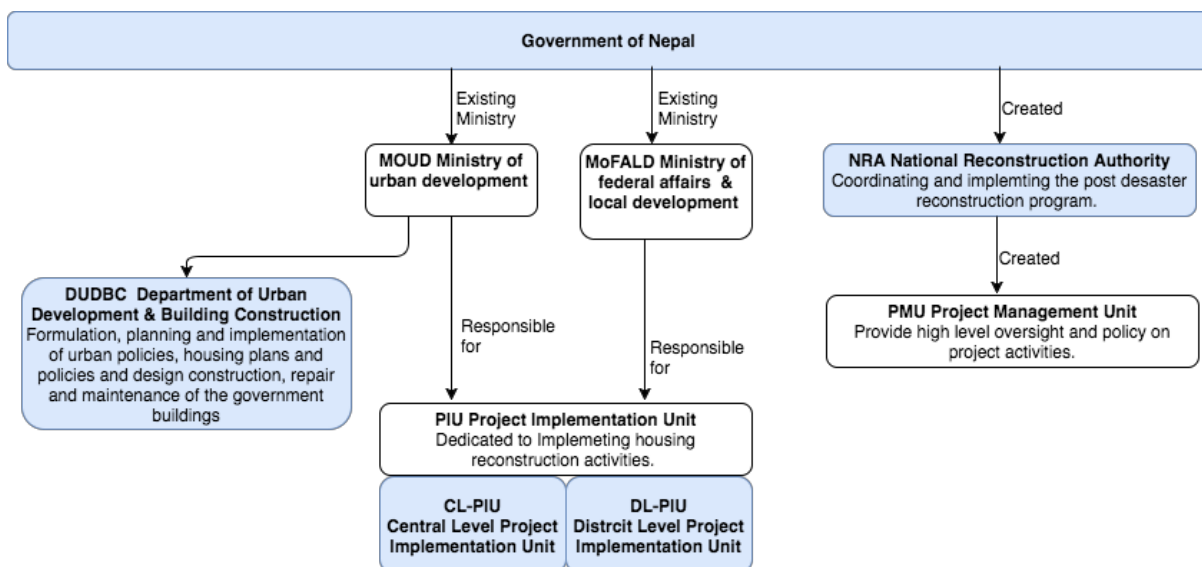

Figure 73: Governmental organisational structure (SSN5)

### 13.2.3 HRRP

HRRP aims to provide a platform for coordination, strategic planning, and technical guidance for agencies involved in longer term housing recovery and reconstruction, and to engage with the Government of Nepal and other key stakeholders to inform the wider housing reconstruction programme. HRRP is funded by Department for International Development - UKAID (DFID - UKAID) and Swiss Agency for Development and Cooperation (SDC). Since then the difference between the NRA and the HRRP are that the HRRP acts as a translator of the information given by the NRA into information that is understandable to the masses according to the CEO of Build Up Nepal. (Appendix II.B)

### 13.2.4 NRA

After the earthquake, the Recovery and reconstruction workgroup was formed which transitioned to the HRRP on September 10th, 2016. On December 25th, 2016, the National Reconstruction Authority was established. (HRRP, 2017) The NRA has been established for a five-year period with a possible extension of one year, during which all identified recovery and reconstruction activities are expected to be completed. Therefore, the NRA requires the functional autonomy and institutional capacity to implement and coordinate the recovery programme expeditiously. This includes having efficient administrative and financial approvals and accelerated procurement and fund disbursement procedures that conform to government requirements.

### 13.2.5 DUDBC

DUDBC is organizing large scale projects to rebuild Nepal. Besides the earthquake situation also other interests on urban developments and construction. The responsibility of DUDBC are formulation, planning and implementation of urban policies, housing plans and policies. Furthermore, the design construction, repair and maintenance of the governmental buildings. The vision of DUDBC for the long-term is a safe, economically and environmentally friendly building construction, affordable housing and sustainable urban development. (Department of Urban Development and Building Construction, 2017)

### 13.2.6 IGO

The inter-governmental stakeholder that has been analysed is International Organisation for Migration (IOM). This organisation is powerful, as it is the world's-leading UN migration agency and works closely with the government. (International Organization for Migration, 2017)

### 13.2.7 NGOs and INGOs

There are around 170 NGOs and INGOs active in Nepal at the moment and there are 23000 smaller foundations active in the country. Post-earthquake the Housing Recovery and Reconstruction Platform (HRRP) has played a role in organising these organisations to work together and to assign areas to work in to the organisations. It was established in 2016 to support housing reconstruction and recovery in earthquake-affected areas of 14 of the most affected districts. It is co-led by IOM in partnership with UN-Habitat. (HRRP, 2017)

### 13.3 Power Interest

The stakeholders have been placed in a Power Interest grid in Figure 74 below based on the analysis of the stakeholders as described in the extensive table in Appendix II.A. The table is based on interviews and background research with the named stakeholders and the stakeholders they collaborate with. The level power of the stakeholders shows whether they can affect the issues future. This framework helps to determine which players' interests and power bases must be considered in order to address the problem or issue at hand. 'It also

helps highlight coalitions to be encouraged or discouraged, what behaviour should be fostered and whose 'buy in' should be sought or who should be 'co-opted'.' (Bryson, 2004) The matrix is divided in four parts which determine the different type of actors; subjects, players, crowd and context setters. This power / interest matrix forms the basis for further analysis of the stakeholders described in the following paragraphs of this report and the engagement plan in 17.2

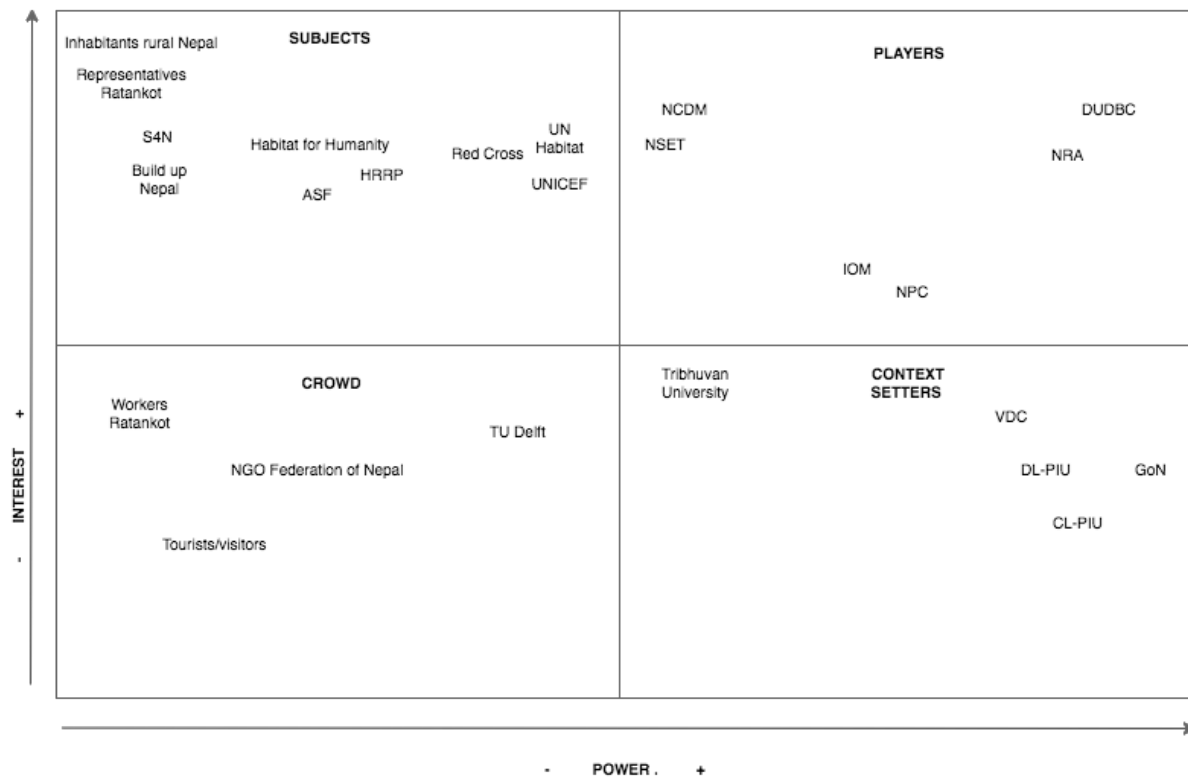

Figure 74: Power Interest Matrix (SSN 5)

*Stakeholders categorised with P/I matrix:*

**Players:** *NCDM, NSET, IOM, NPC, DUDBC, NRA*

Governmental organisations concerning rebuilding Nepal after the earthquake are the players, because they have high power and high interest. The players should be managed closely and can be seen as key players. This can be realised by communication and transparency.

**Context setters:** *Government of Nepal, CL-PIU, DL-PIU, VDC, Tribhuvan University*

The governmental organisations concerning the legislation and approval of designs are the context setters, as they have the decision-power in what can and what cannot be legally built, therefore they have to be kept satisfied in order to receive government grants. Their rules and regulations can be restricting. An exception is Tribhuvan University, as they work closely with the government due to their technical expertise and engineering knowledge. The context setters should be kept satisfied, as these actors have high power and decide about the legislation, except for Tribhuvan University.

**Subjects:** *Inhabitants rural Nepal, Representatives of Ratankot, Support4Nepal, Build Up Nepal, Habitat for Humanity, ASF, UN Habitat, Red Cross, UNICEF, HRRP*

The NGOs, the coordination platform HRRP and the inhabitants of rural areas are the subjects; their interest is high because in the end these are the actors that are highly motivated in rebuilding Nepal, however they are dependent on other stakeholders to achieve their goal which gives them low power. The subjects should be kept informed and two-way communication needs to take place. This can be realised by close communication.

**Crowd:** *NGO Federation of Nepal, TU Delft, Workers Ratankot, Tourists/visitors*

The actors with low interest and low power are the crowd, as they are 'on the side line'. Tourists, visitors, the NGO Federation of Nepal. The workers of Ratankot belong to this type as well, because they do not necessarily have high interest in the project itself, except when they are also inhabitants. The TU Delft does not have high power in this matter, nor high interest. The crowd should be monitored and informed about the project.

### 13.4 Power Interest Attitude

Elaborating on the Power Interest Matrix and to get a clearer picture of the type of actors and their possible behaviour towards SSN, a third factor is added; *attitude*. With this factor stakeholders can be determined as either backers or blockers, as seen in the Murray &

Webster graphical presentation in Figure 75: Murray-Webster & Simon graphical presentation with stakeholders regarding rebuilding Nepal in relation to SSN. Figure 75 (Murray-Webster & Simon, 2006). Knowing whether the stakeholders are backers of blockers, it becomes clear through which network path the goal can or cannot be reached.

#### POWER/INTEREST/ATTITUDE OF STAKEHOLDERS

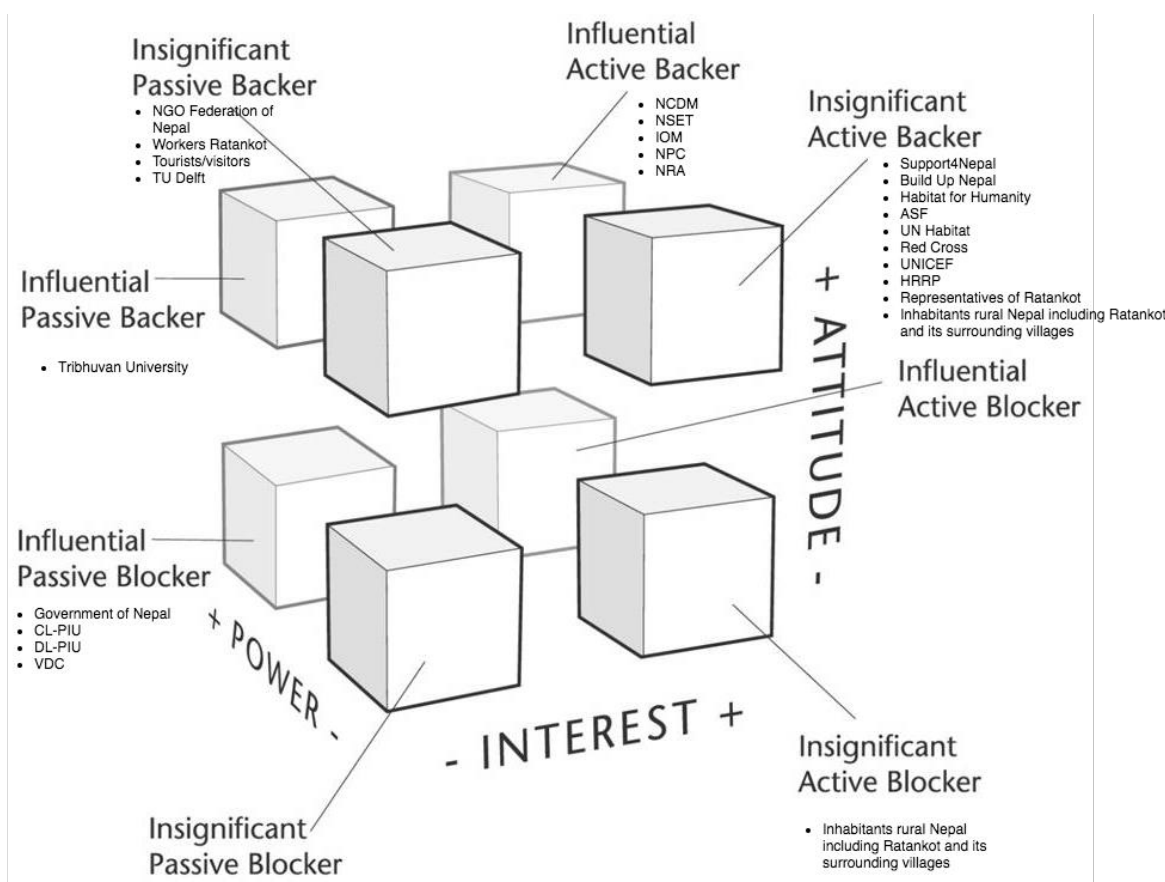

Figure 75: Murray-Webster & Simon graphical presentation with stakeholders regarding rebuilding Nepal in relation to SSN.

Type of actor according to Figure 75 above:

#### Backers

- Influential and active backer (saviour): Governmental organisations regarding disaster management are all backers, as their goal is to help Nepal after a disaster.

- Influential and passive backer (sleeping giant): Tribhuvan

- University is a backer, as they want to share knowledge concerning building earthquake resilient.

However, passive as they are steered by GoN in this matter.

- Insignificant and active backer (friend): NGOs and HRRP are backers, as their main goal is providing the locals with sufficient shelter as soon as possible. However, they are dependent on the government and have to follow their rules.
- Insignificant and passive backer (acquaintance): Tourists, visitors, the NGO Federation of Nepal are backers. They have no reason to be blockers as it is regarding a natural disaster, however they have little power.

#### *Blockers*

- Influential and active blocker (saboteur): In the category players there are no blockers, which is positive because of the high power.
- Influential and passive blocker (time bomb): The governmental organisations have to keep satisfied, as they can block the process of approving the designs of the houses which affects grants.
- Insignificant and active blocker (irritant): The inhabitants of rural areas could be blockers, as their attitude is sceptical towards the houses, as it has to be according their cultural standards.
- Insignificant and passive blocker (trip wire): There are no blockers in this matter.



## 13.5 Network Analysis

In the network analysis, the relation of the stakeholders to each other are analysed and shown in Figure 76 below. It is a representation of the important stakeholders in earthquake resilient building and the relationships.

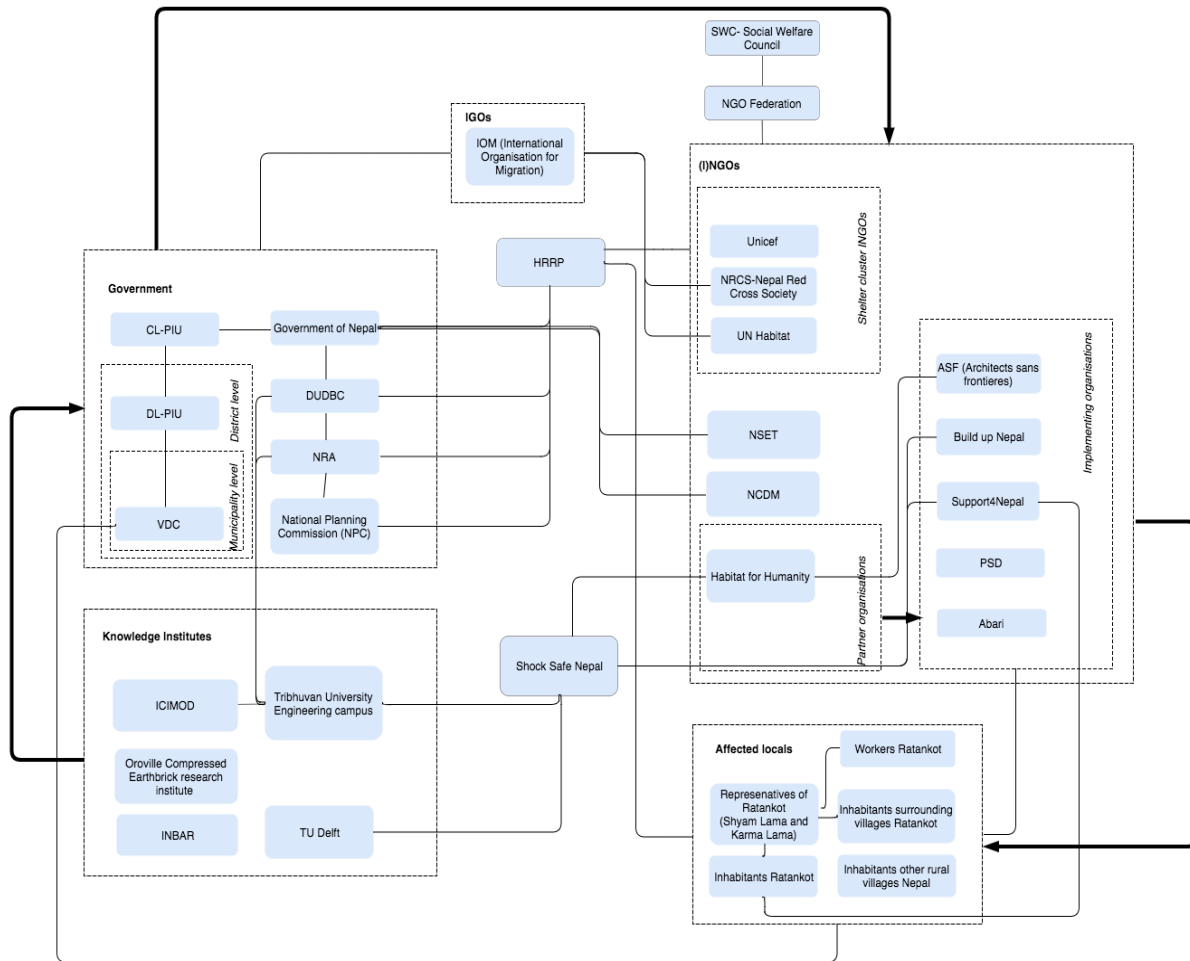

Figure 76: NETWORK ANALYSIS OF SSN: Organisational chart with the relation between SSN and stakeholders

The network analysis has been done regarding Shock Safe Nepal and its relations, therefore it is the centre of the organisational chart. The system is extremely complex, mainly because of Nepal's governmental system. It becomes clear in figure 5.4 that there are many steps to take before for example the locals can reach the government. The locals rely on the (I)NGOs, as the NGOs are directly

connected to them and actually rebuild houses and provide technical assistance. NGOs are registered at SWC and are part the NGO Federation. The NGOs can be split up into Partner Organisations and Implementation Partners. As an educational institute, SSN is dependent on (I)NGOs regarding implementation to connect with the locals as well as the government. The government has high power, as the

government sets up the requirements for the designs and thus the grants. VDC is responsible for approval on municipality level, DL-PIU on district level and CL-PIU on national level. Therefore, the (I)NGOs are dependent on the government as well. In §14, this will be further described in combination with the external factors. For technical knowledge, governmental organisations DUDBC and NRA consults research and knowledge institutes, such as Tribhuvan University and ICIMOD. SSN has connections with mainly TUD and Tribhuvan University and is partnering up to exchange knowledge and test designs, as only then we can reach the government with improvements. Umbrella organisation HRRP collects and provides information of and for all stakeholders, including the steps that need to be taken, the requirements regarding the design and funding.

## 13.6 Conclusion

Nepal has a complex network of stakeholders, which makes it difficult to reach other stakeholders not directly connected to each other, including SSN. In specific governmental organisations, because of the non-transparency and speed of regulating, arranging, organising and funding. The government consists of various sub-organisations which focus on rebuilding Nepal after the earthquake, such as DUDBC, NRA and NPC. As part of the ministries, CL-PIU and DL-PIU are responsible for the legislation regarding the designs, respectively on national level and regional level. VDC is responsible for legislation of designs only on village level. Regardless, governmental organisations have high blocking power that can stop the whole process. Knowledge institutes such as Tribhuvan University are asked by the government to help with research regarding earthquake resilient building. However, as

they are a knowledge institutes, it is the government that consults them. We have worked together with Tribhuvan University and, as we are still a research institution, we should continue this collaboration to improve the knowledge in earthquake resilient building and to test designs. HRRP, the umbrella organisation connects the NGOs and locals with the government. They give presentations and information on how to approach certain matters such as legislation and funds. However, they are only a knowledge platform and do not perform research nor do they act as an NGO. Furthermore, there are almost 40,000 NGOs active in Nepal. (Social Welfare Council Nepal, 2017) As to be seen in the network analysis in Figure 76 relations between the stakeholders are extremely complex. The locals are connected through NGOs and HRRP to other stakeholders, therefore NGOs are extremely important for the locals. SSN has collaborated with Habitat for Humanity, Build Up Nepal, Support4Nepal and Architecture sans Frontieres. We are looking forward to continuing this collaboration in the future, as they have added great value to SSN. However, as the organisation is complex, SSN should focus on being a research group, rather than implement houses.

# 14 External factors

Development and rebuilding of earthquake resilient housing is more than construction. If upscaling would be the only problem, then it would be not that difficult. Unfortunately, this is not the only problem. Questions arise regarding problems such as poverty, and education as these aspects also ask for attention. In reconstructing Nepal many aspects are involved, such as physical, social and economic recovery. Community, family activities, but also infrastructure, livelihood, water and sanitation and mobility. Settlement recovery activities require integrated and coordinated planning with several sectors and on different levels. How can SSN, with all these challenges in mind, develop a long-term plan to upscale earthquake resilient building?

Occurrence of few damaging earthquakes during the last decade in Nepal and adjacent areas has pointed to our shortcoming in risk reduction programs. A meaningful program must incorporate, research, apposite building codes, and also effective public awareness plan. Several initiatives are now being taken at research and management levels in Nepal. In this contribution, both technical (e.g. seismicity, seism tectonics, nontectonic) and risk management practices (e.g. legislation, national plan, awareness programme) and their shortcomings are discussed. (Chamlagain, 2009) In order to create a long-term plan the external factors have to be determined in relation to SSN, as well as the opportunities and barriers, focusing on implementing the design which is applied in Ratankot, in other areas in Nepal. Therefore, a STEEPLE analysis is presented in this chapter. STEEPLE is a framework regarding macro-environmental

external factors, which gives a clear overview of the Social, Technical, Economic, Environmental, Political, Legal and Ethical factors. Team one has set a foundation of the context of this project. This report elaborates further on the research of SSN 1, Chapter 3.

## 14.1 Social factors

This project is of great social relevance and people in rural Nepal have a different way of living than Western countries. Therefore, this aspect is essential to consider when designing an earthquake resilient house. This paragraph consists of elaboration on the cross-cultural differences and the factors regarding the STEEPLE analysis; income distribution, demographic changes, labour and social mobility and lifestyle changes.

### 14.1.1 Cross-cultural

There are several cross-cultural differences between Nepal and The Netherlands, which can be determined with the six dimensions of Hofstede. (Hofstede, Hofstede & Minkov, 1997, p.53) According to team 1 (SSN 1, 2015, p.13) Nepal is a country with high power distance, collectivism, masculinity, indulgence, short-term orientation and low uncertainty avoidance.

The high-power *distance* means that hierarchy is accepted in Nepal. This explains the great differences between the poor and the rich. Regarding the project, the high dependency is a factor to consider. People 'lower' in the ranking are dependent on people 'higher' in the ranking, therefore representatives of a village have to steer the workers in rebuilding earthquake safe.

*Collectivism* is high in Nepal. The group is greater than the individual. Young people tend to leave the rural areas where they grew up and move to cities or go abroad. By earning money abroad, they support their

families. (IOM - UN Migration Agency, 2016) Especially in the villages this aspect is recognisable as people are seen as families not so much as individuals.

The high *masculinity* is compared to The Netherlands where competition, achievement and success are important factors, however Nepal is still a feminine society. Regarding rebuilding, this is recognisable due to the fact that women also are part of rebuilding Nepal. However, the percentage of women working is still lower than men. After the earthquake both men and women were living in the same area and the same shelters and women got harassed and assaulted. Therefore, safe shelter where women are and feel safe is of great importance. (IOM - UN Migration Agency, 2016) However, a gender gap still exists. For example, household work is 38.7% female against 4.6% males. (CBS, 2017) Creating gender equality is difficult due to the patriarchal mind set in Nepal.

A couple of days after the earthquake the Nepali were concerned with an earthquake resilient house. This amount dropped quickly, even a week later. Compared to The Netherlands people have a different mind-set. According to the villagers of Ratankot (Appendix II.B) they are more relaxed and live day-by-day. Therefore, the low *uncertainty avoidance* and *short-term orientation*.

This leads to the final dimension, *indulgence*. Nepali value tradition, basic and human desires and preservation. They are not as materialistic as people in The Netherlands, nor focused on status. Due to this different perspective, people seem more content even though they have less regarding materialistic aspects. Architecture Sans Frontieres explained in an interview (Appendix II.B) regarding the preservation aspect that locals in rural areas rather have safe storage for their belongings than for themselves as a result that for example the

rice is stored inside the shelter and the people themselves sleep outside of the shelter.

### 14.1.2 Income distribution

A survey of the Central Bureau of Statistics (2017) showed that 80% of the Nepalese are employed, 2.7% is unemployed and 17.2% are out of labour force. However, in the rural areas 78.6% is working in the agriculture, forestry and fishing industry. 57.9% is self-employed in the agriculture industry, and only 14.8% works in paid non-agriculture. (Central Bureau of Statistics, 2017) The employment rate is relatively high, due to taking the non-paid jobs also into account. In rural areas, the income distribution is differing from the urban areas, as more than half of the population is self-sufficient in the rural areas. Furthermore, 25.2% of the Nepali live under the poverty level and many people are dependent on their families. The minimum income level people in rural areas need for living is 12.000 NRPS, which equals 100 euro per month (De Mey, 2016). For comparison, building an earthquake resilient house costs at least \$3000 and thus is 30 times as much. (SSN4, 2017) Therefore, grants for rebuilding houses are essential.

### 14.1.3 Demographic changes

The population as well as the life expectancy has been growing for over 60 years (Worldbank, 2017). In 2015, the population of Nepal consists of 47.4% male and 52.6% female. 46% of the population is between the age of 15 and 44 years old. (Central Bureau of Statistics, 2017) Due to lack of educational opportunities in Nepal, many young people leave the country. 2.2 million of the youth migrates to foreign countries. This youth has a great positive impact on the economy and contributes to 32.1% remittance flow of Nepal. This remittance

results in financial relief for their families in Nepal. However, due to this migration the manpower of the young population decreases and thus the tradition of filial support decreases. After the earthquake, young migrants actually returned to their hometown to support their families and country. (Regmi, 2016) Another noticeable change is the increasing literacy rate. The literacy rate of people in urban areas is 74.4%, whereas in the rural areas this rate is 58.6%. However, the literacy rate of older people is significantly lower than young

people (Figure 77). The gender difference of 76.2% men and 53.3% is noticeable as well. 33.7% of people in rural areas never attended school which explains not being literate. From this figure can be concluded that education used to be a privilege and that it now has been increased. Being educated, gives the youth the opportunity to migrate. Regarding the project, transfer of knowledge could be a problem when educating the locals in rural areas on how to rebuild their houses, as 41.4% of the people lacks literacy skills.

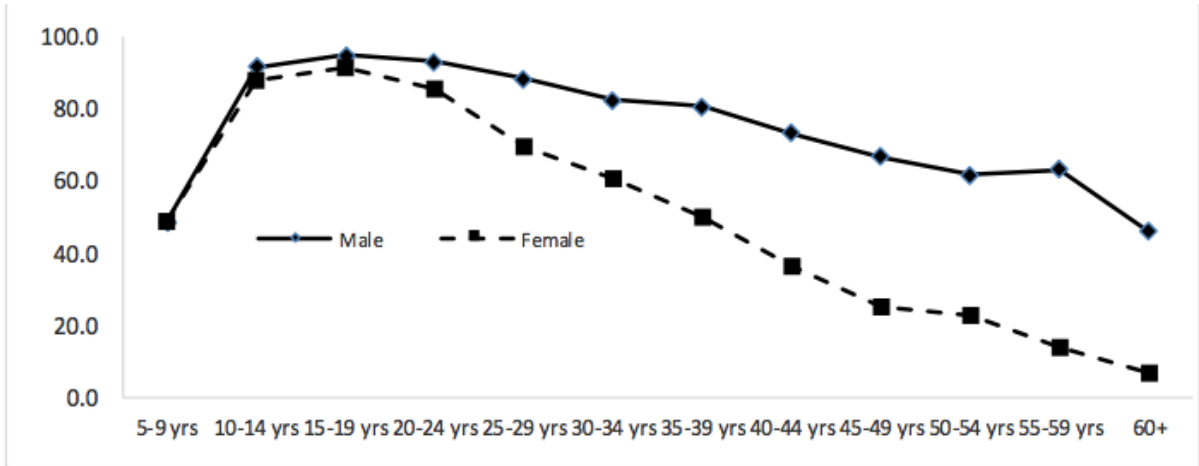

Figure 77: Literacy rate of male and female by age groups

**Labour/social mobility**

One week after the earthquake 100.000 people moved from Kathmandu back to the rural areas, which shows that urban populations are highly mobile, on labour aspects as well as social aspects. (Sanderson, Ramalingam, Baker, Duyne Barenstein, Currion, Decourte and Young, 2015) In contrary, in rural mobility is low. Labour mobility because 78.8% work in agriculture, 57.9% self-employed (Central Bureau of Statistics, 2016), and this is location-bound. This results in not being able to easily move to other places, as the agriculture is their income. Social mobility is

also low due to the fact that less people in rural areas are non-educated compared to urban. In rural areas 31.7% of the people have never attended school and 20.3% in rural areas. Also, this percentage is twice as much for males (18.5%) compared to females (36.7%) (Central Bureau of Statistics, 2016). This makes moving more difficult than for example the young educated that migrates abroad. Regarding the project the local workforce is scarce. Mainly because of the lacking knowledge on how to build earthquake resilient. Therefore, technical assistance is important so people can be trained and be assisted along the rebuilding process. This will generate jobs

and thus financial relief as well as well-built houses.

### *Lifestyle changes*

Most of the children are educated nowadays. This will result in a society where the young will be educated and thus literate. Young people then tend to move abroad as foreign countries give them more opportunities regarding education, work and way of life. As said before, this will have negative influence on the tradition of agriculture in the hometowns of the youth. However, this also can have a positive influence. Looking at the representative of Ratankot, Shyam Lama, it has helped Ratankot in an extremely positive way, as he coordinated the reconstruction of a new school as well as the pilot building. His brother Karma Lama lives in Kathmandu with his family, but has 'one foot' in Ratankot which is valuable, meaning that he is doing many things to create opportunities for the villagers.

### *Findings from field research*

Earlier research has shown that bamboo was not according cultural and religious standards. However, SSN 4 chose to build the roof of the pilot house with bamboo regardless, for several reasons such as low costs and bamboo being a strong and light material. The inhabitants of Ratankot were reluctant at first. To get to the core, an interview found place with the locals of Ratankot about their thoughts on the pilot

building and possible other housing, as well as the representatives of Ratankot, Karma Lama and Shyam Lama. These interviews can be found in Appendix II.B Seeing that the house 'works' as it is being build, their opinion changed and they have accepted that the pilot house has a bamboo roof. From these interviews, we can conclude that the pilot building is according cultural and religious standards. They even said that they are interested in a house build completely out of bamboo. We have to consider that this does not automatically means that people in other rural areas also will accept. Furthermore, the inhabitants did not seem eager on building such a house for themselves. The people possess very little and therefore do not look far in the future. Their aim is to have a roof above their heads, and not necessarily an aesthetically pleasing earthquake resilient house. The model must be based on the needs of the community and the local people. If they do not have any benefit of the house, it will serve no purpose.

## 14.2 Technical factors

### *Structural design pilot house*

In order to be able to implement the design in other rural areas in Nepal, the constructional features of the design of the house has to meet the requirements of the Nepalese legislation. An extensive analysis of the legal factors can be found in paragraph 14.6



## Technical Assistance

Technical assistance in especially remote areas in Nepal is crucial in rebuilding an earthquake resistant/resilient Nepal. However, it has been a problem getting this technical assistance to the areas that need it. When an NGO accepts to provide technical assistance to an area this means that they take full responsibility over this area, they have to give monthly updates to the NRA and HRRP. These updates include housing support, writing reports completed with spending per quarter. (Groff, 2017)

The NRA has formatted the following six types of technical assistance that can be given:

1. Community/household orientation with more than one session.
2. Continuous door to door technical assistance
3. Short training for masons

4. Vocation/on the job training for masons
  5. Helpdesk/Technical Support Centre
  6. Demonstration construction
- (HRRP, 2017)

## Types of technical Assistance

By the NRA short trainings have been organised in different districts. This can be seen in the map on the right, as can be seen in Figure 78. There are still areas where the target number of training have not been reached. (Notice that the map goes until 643% of the target). Another aspect that is important to realise is that these are short trainings, this means that there is not necessarily a follow-up as is the case when certain organisations work on training. According to an interview with HRRP currently 44 out of 119 VDCs have technical assistance, which is incredibly low nearly two years after the earthquake

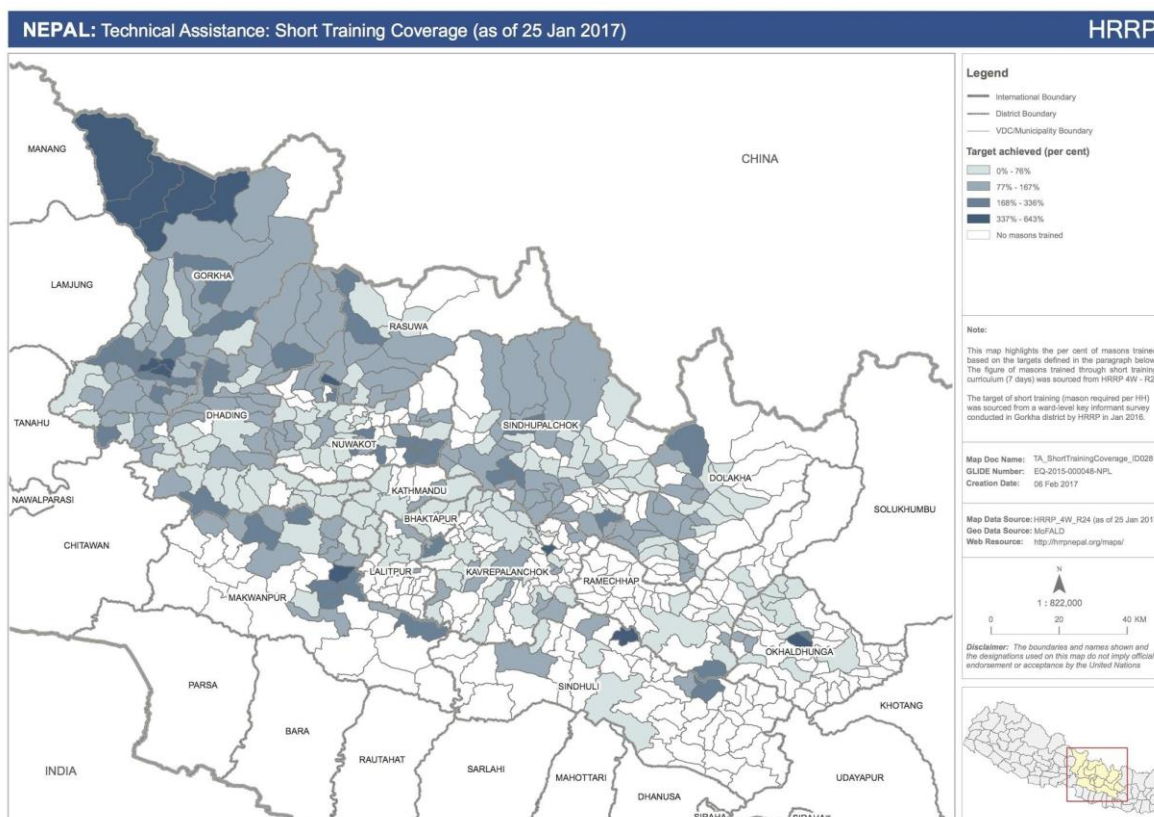

Figure 78: Technical Assistance short trainings per area (HRRP, 2017)

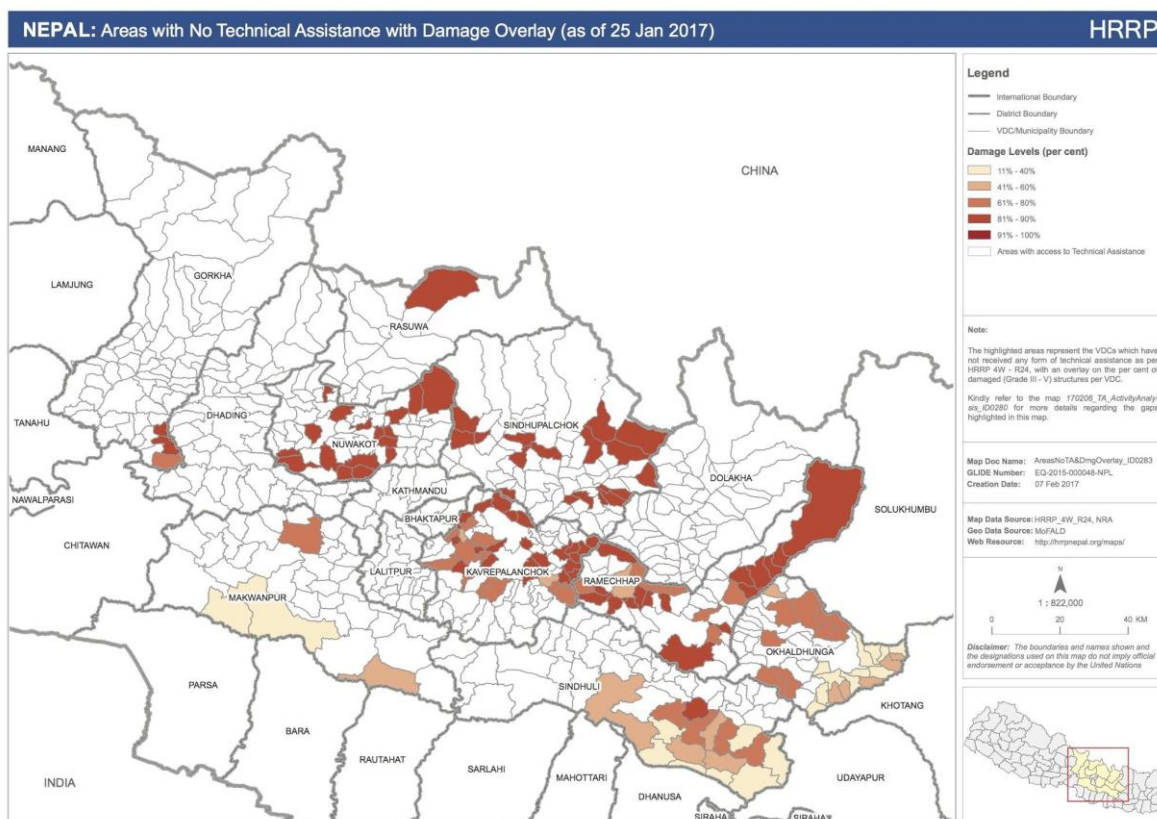

Figure 79: Areas with no technical assistance with damage overlay. (HRRP, 2017)

As can be seen in Figure 79 there is still a large gap in technical assistance being given in certain areas. Although, there are a lot of organisations in the field giving assistance but there are many people living in rural areas that do not have the possibility to get to the information that they need through the methods that the government has proposed. This also creates cases where people build, but not according to the approved guidelines of the government, which makes it almost impossible to get the grants for housing. This is because the government wants full control of the used designs and methods and therefore aims on rebuilding that is according to the NBC and Building Code to ensure safe buildings. By giving grants when rebuilding is done according to the building code, the government wants to insure the safety.

### Technical Assistance in Practice

An example of how technical assistance is brought into practice is that Habitat for humanity has set up 3 Housing Support Service Centres (HSSC, 2017). These are located in the 3 VDCs that they are active in. The HSSC serves as a hub that people can go to for advice on house designs, information about government building codes and NRA's guidelines to families seeking grant for building new homes.

## 14.3 Economical

According to the Human Development Index in 2014 Nepal ranked the 145th nation (UNDP, 2015). It is one of the 48 Least Developed Countries as stated by the United Nations regarding the fact that they belong to countries that have the weakest gross domestic product (GDP), the lowest ratings in health and literacy indicators, and the lowest capability to cope with natural disasters or economic disruptions. (United Nations, 2015)

### 14.3.1 Import & Export

The main countries that Nepal imports from are China and India, China 15% and 61% respectively. The main countries that Nepal exports to are India with 62% and the United States 8% (Simoes, n.d.). This is one of the reasons that the stopping of trade with India in 2015 had such a large impact on the country. (Andrew, 2016)

### 14.3.2 Migration economic effects

Because of the fact that Nepalese can earn more in other countries, there are a lot of young people that work abroad and send money back to Nepal. Young men also often do manual labour in surrounding countries.

### 14.3.3 Earthquake effect

The 2015 Earthquake did a lot of economic damage. According to the National Planning commission, the total damage and loss from the earthquake was around US\$7 billion, this is one third of the 2013/2014 GDP (US\$19 billion). The international community pledged an amount of US\$4.4 billion financial support for reconstruction. However, another US\$2.2 billion was given as a loan, increasing the national debt. The economy of Nepal relies heavily on international assistance. The amount of

loans has increased, the amount aid in the form of grants has decreased. (Regmi, 2016)

### 14.3.4 Migration of youth

Agriculture provides income for more than 70% of the Nepali population and just over one third of the GDP (Central Intelligence Agency, 2016). About 2.2 million Nepalese youths working in foreign countries as migrant workers constitute a major source of national economy. As of 2016, the remittance inflow of Nepal is 32.10% of the total GDP (MOF Nepal, 2016). Because of the large amount of migration, elderly people do not get the traditional support in their villages from children that would have been the case previously, many lands are left because of the lack of the younger workforce. (Regmi, 2016)

### 14.3.5 Village economy/grant donation/subsidy

Except for the national economy, the economy of villages on a smaller scale is important too. The rural areas that SSN focuses on do not play a large role in the national economy in terms of trade. However, people do want to invest in their houses and often find ways to do so. (HRRP, 2017) In the village of Ratankot there is no balance between money coming into and leaving the village. It is important to make sure that money for reconstruction goes to local people, who you also want to support through the building of the house. This means employing local masons, and educating them so that they can bring more money into villages. For people in Rural areas the \$3000 grant is a substantial amount. For people who do not have family abroad or working in large cities sending them money it is essential to receive the grant to be able to rebuild their houses. It is also important to realise that it can have a lot of impact to use local materials and put as

much of the \$3000 grant back into the community or area. This can be done by investing in existing small companies or setting companies up around the materials that are used, for example the interlocking CSEB brick company and the bamboo farms and treatment facility that are being worked on in Ratankot. This way material costs decrease and jobs are generated. It is also possible to find locals which have a lot of land or money to sponsor the reconstruction of their village. The costs of the design must be seriously taken under consideration, compared to other buildings in the building code. For locals to be able to afford and built the house they must receive the financial aid. The costs of the house must be of the same amount as the financial grants.

### 14.4 Environmental

The environment has a large impact on the other aspects in Nepal. Nepal is vulnerable to various types of natural disasters like mass movements landslides, floods, Glacier Lake Outburst Floods (GLOFs), climate,

topography, fragile geological structures and intense rainfall, (Chamlagain, 2009) and of course earthquakes. This is because the country is located on the ridge between two active tectonic plates: the Eurasian and Indian Plates. One of the reasons behind Nepal's poverty and economic backwardness when looking at the history of occurrences earthquakes, is its location. Nepal was hit by massive earthquakes not only in 2015 (7.8 magnitude), but also in 1934 (8.4 magnitude), 1980 (6.5 magnitude), 1988 (6.9 magnitude), and 2011 (6.9 magnitude). (NPC Nepal, 2015) (Regmi, 2016) This geographical fact makes the development of the economy challenging. Other environmental problems that Nepal faces are deforestation because wood is overused for fuel and there is a lack of alternatives, contamination of water, with waste from human and animal, agricultural runoff, and industrial waste, wildlife conservation and emissions from vehicles. (Central Intelligence Agency, 2016)

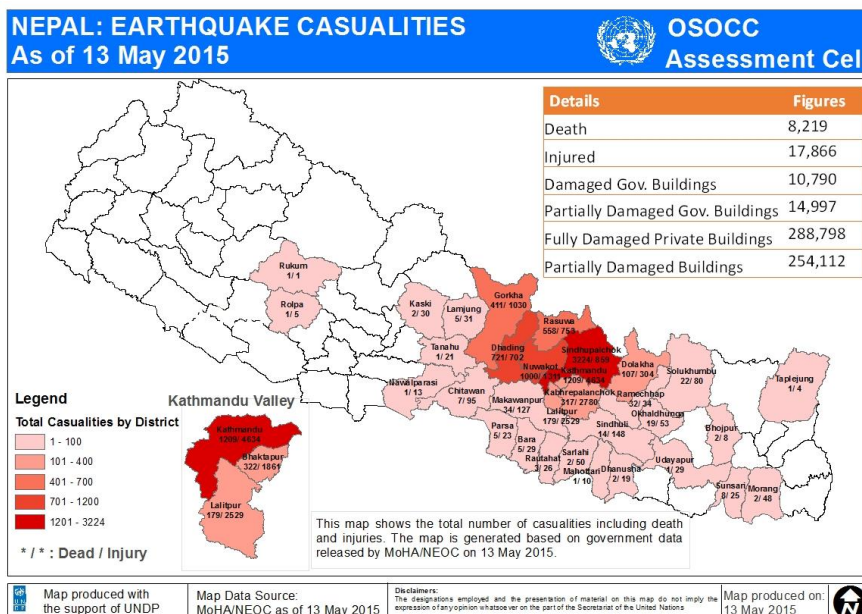

Figure 80: Earthquake casualties. (UN Nepal Information Platform, 2015)

As can be seen in Figure 80 the earthquake of 2015 had most casualties including death and injuries in Sindhupalchowk, Nuwakot, Dhading, Gorkha, Rasuwa.



### 14.4.1 Impact of climate change

In Nepal, there is a high rate of dependence on subsistence farming, low level of development, a high poverty rate, its geographic location in a mountain basin and the fact that agriculture, hydropower and tourism are all important for its economy. Nepal is one of the countries that is most vulnerable to climate change amongst developing countries (Maplecroft, 2011). Its geographical location leads to climate risks like GLOFs. Nepal is also vulnerable to the general impacts of climate change, such as rising temperatures, erratic rainfall patterns and incidents of drought. Within Nepal the middle hills region is stated as one of the most vulnerable. This is because of a complex mix of social, ecological, political and economic factors and the fact that there are high variations in the landscape. As a result of the caste system there are multiple different socio-economic and ethnic groups which make the vulnerability depending on climate change differ throughout this area. (Sapkota, Keenan, Paschen & Ojha, 2016)

### 14.4.2 Geography

Nepal is very mountainous country which is one of the reasons why development can be difficult. Villages are often far away from cities and transportation to cities costs a lot of time and often money. It is important to realise where materials come from in the design of buildings. Transport of materials from larger villages means that the final house costs more and has a larger impact on the environment. Regarding the design of SSN, the used material CSEB is made in the Ratankot itself, which means there is little transportation costs compared to bricks that are not made not on site. This aspect can be seen as environmental friendly, as well as the bamboo used for the roof. The geographical situation has influence in where to and where not to build for SSN when upscaling the project in the future.

## 14.5 Political

### *Unstable political situation*

Politics is central to the rebuilding process and all earthquake relief in Nepal. It is an important aspect to consider and the role of the government should not be underestimated. (Andrew, 2016) The instability of the Nepal politics became obvious after the earthquake on April 25, 2015. The government failed to respond to the earthquake in a timely manner. (Billingsley, 2016) In the aftermath of the earthquake, it has been said that instead of focusing on the humanitarian needs of the people of Nepal, the political leaders put more effort into fast-tracking a new constitution. One of the passages of the constitution led to a blockade of the border with India, which seriously compromised transportation and the availability of critical goods during this time, such as medicine and food. (Andrew, 2016)

### 14.5.1 Power of politics

Nepal has a complex and unstable political system. Until May 28, 2008, Nepal was a constitutional monarchy. On that date, the constitution was altered by the Constituent Assembly to make the country a republic. Legislative power is invested in the government and the president. Executive power is exercised by the Prime Minister and his cabinet, while legislative power is vested in the Constituent Assembly. Nepal is currently rated as 131 out of 176 on the corruption list (Trading Economics, 2017). In 2016 after Nepal's Prime Minister KP Oli has stepped down as a key coalition partner, the Communist Party of Nepal (Maoist-Centre) led by Prachanda, withdrew support for the government. A new government has been formed, which is to be the ninth in the last eight years. The government led by Oli of the Communist Party of Nepal (Unified Marxist–Leninist), that was formed soon after

formally making known of Nepal's new constitution, has served for nine months. The fact that changes in government in Nepal are frequent have gravely hampered the nation's development and economic growth. Indeed, even after the new

constitution's declaration, there is no indication of political steadiness in Nepal. Politics is still dominated by government toppling and forming. (Bhattraai, 2016)

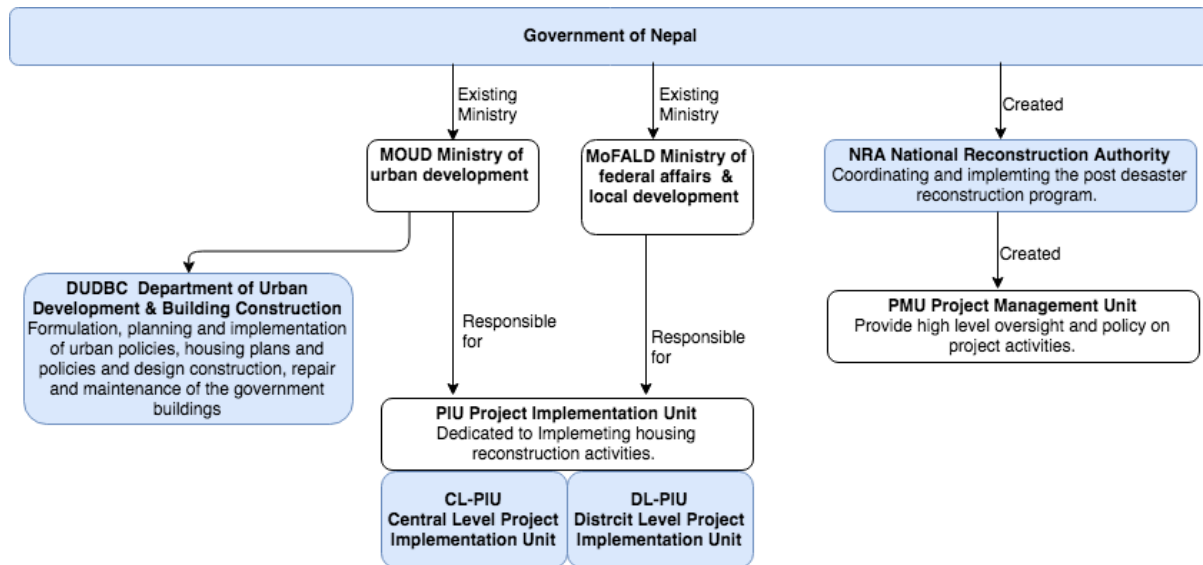

Figure 81: The organisation of the government and regarding post-earthquake reconstruction (SSN5)

Figure 81 describes the structure of government organisations regarding rebuilding of Nepal. The government organs that concern rebuilding are the National Reconstruction Authority (NRA), and organisations on central, district and municipal level. These are the DUDBC, DL-PIU, CL-PIU and VDC. Both the Ministry of Urban Development (MOUD) and the Ministry of Federal Affairs & Local Development (MoFALD) are responsible for the CL-PIU and DL-PIU, which are project implementation units on central and district level. The NRA was created to dispense the \$4.1 billion dollars that was donated by international donors. Forming of the NRA took eight months after the earthquake, partly because of bickering within the government about who would become the director of the authority that holds power over a large amount of money this. (Andrew, 2016) The NRA was established to exist for a five-year period with possible extension of

one year. It is expected that this is the needed time for the recovery and reconstruction to be finished. (Andrew, 2016)

### 14.5.2 Power in rebuilding

The government of Nepal has large amount of power in decisions regarding rebuilding of Nepal. Although the government grant structure would be effective in rebuilding the country, it has been criticised for being too late in this matter. The initial thought of the building grant would have been good if it had been done a year ago. Then people could have got started. The idea behind giving the \$3000 grant in three steps could have been successful, however, it is not seen as this by (I)NGOs at the moment. "The concept is right just the implementation is not. There is a failure of government principles," (Build Up Nepal, 2017). After the earthquake, the NRA



also controlled operations of NGOs in rebuilding, this was done with the expressed objective of having an organised and libertarian implementation of help. However, it meant that NGOs had to get approval to start rebuilding individual homes, approval that was only given in April 2016. This is several months after organisations could have kick-started the rebuilding process. To be able to start, NGOs and inhabitants of rural areas began by rebuilding schools and community centres that are not individual homes as regulations did not apply to these types of buildings. (Andrew, 2016) Besides the schools and community centres, organisations such as Build Up Nepal also started building model homes that can be used to show approved building architecture, sustainable design and earthquake resistant building techniques until rebuilding homes becomes legally possible. (Andrew, 2016)

#### 14.5.3 Blocking power in politics

Aspects that are related to building in which it is difficult to work with the politics are; getting feedback on designs, the attitude from government workers, not being able to work directly in Nepal as an international organisation and the slow process in general and regarding grant approval. For NGOs, getting feedback on designs for buildings that they are planning to build, it takes at least a month for the government organisations to get back to them. It took a year and two months after the earthquake before NGOs were legally allowed to start rebuilding. (Appendix II.B)

#### 14.5.4 Funding through government

It can be said that in the case of rebuilding Nepal the modernist top-down model of development – that is taken for granted by both government and donors alike– has according to Regmi (2016) "created roadblocks towards understanding Nepal's contextual realities". The top-down model

refers to "development from above" instead of "development from below" (Butcher, 2006) in which development support is given or organised by the government or large organisations instead of going straight to local people. It is therefore said that it is not possible to have sustainable reconstruction and development without strengthening the capability of local communities.(Regmi, 2016). It is important to realise and work with these possibilities instead of working solely through the government.

On the other side of this problem is the fact that the government is responsible for keeping or creating high technical quality of the building being done in Nepal which is a challenging issue. Therefore, the Nepalese Building Code has to be complied with by company's eager to build. There are many different NGOs and although from the government there is a high focus on the need for technical assistance, some NGOs find that rebuilding is taking extremely long. They are working on implementation of rebuilding, not only giving technical assistance required by the government. This means however that there is less funding available for the technical assistance (HRRP, 2017). This is something that SSN teams need to be aware of, although there are regulations from the government that seem to slow down the process of rebuilding in Nepal, it is a country where technical validation is essential but not as easy to regulate as it might be in the Netherlands.

## 14.6 Legal

As explained in the previous chapter, politically speaking earthquake relief has not been handled as effectively as would be wished. Political ownership of the agenda is essential in order for disaster management to be handled by ministries. So far, a lack of political ownership has also translated into a legal framework and its enforcement on important aspects such as building regulations and codes being insufficient. Another reason why it was difficult to enforce existing legislation has been stated as

inadequate government capacity in terms of manpower and resources. (Lee, 2016)

There is a need for strong policy direction and leadership, as well as a supportive legislative framework that is implemented and enforced. (Lee, 2016)

*Approving building designs on different levels*

Figure 82 below shows the legislative steps that need to be taken in order for approval of building designs.

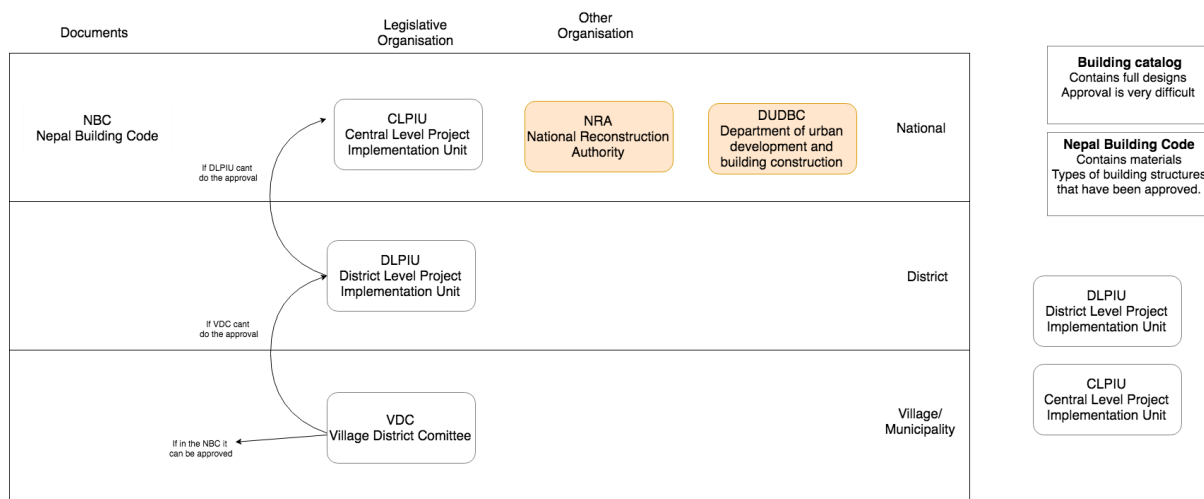

Figure 82: Approval of building designs at different levels (own diagram)

To get designs accepted there are different levels at which they can be approved. New designs need to be approved either by the VDC on municipality level, DL-PIU on district level or CL-PIU on national level. The latter takes a long time, as the aim is to get the design approved in the Nepalese Building Code. For example, a committee of professors is now trying to get bamboo and CSEB in the catalogue, however bamboo as a structure will probably never be approved because there are too many different types of bamboo. It is expected that CSEB will be in the next Design Catalogue as a load bearing structure but regarding bamboo this

will only be accepted for floors and roofs. (Appendix II.B)

The DL-PIU has structural engineers, but no authority. This means that they are not able to check the technical aspects of the design regarding calculations. However, they can send the application through to CL-PIU. If the designs will not be approved by both DL-PIU and CL-PIU, appliance at the VDC is possible per village. However, a VDC does not have experts nor engineers. Furthermore, the design will generally be approved for one household per application. There is a possibility, a so-called 'blank

design', that this certain design will get approved for the whole village

Getting complete approval for a design per house is not efficient for the design of the pilot SSN house in the long term; rather hand in a design that can be used throughout Ratankot, Sindhupalchowk or Nepal. For this, there are two possibilities. Either hand in a design with materials which are already in the NBC or hand in a full design for the catalogue with validated calculations to CL-PIU. However, to get approval for this is very hard. Another possibility would be to get a design approved at VDC per household. However, this then has to be done for every single household. Another possibility is to get a 'blank' application so the design will be valid for the whole village or give the implementation aspect out of hands to another (implementing) NGO.

### 14.6.1 Legislation and Regulation and the Current Setup of Earthquake relief.

Apart from the difference in Village, District and Country impact when looking at the legal aspects of building in Nepal, with rebuilding the country is also organised in the different

districts. In this chapter, the organisation of the rebuilding is analysed according to the areas and districts in which organisations work. The NRA is in charge of disseminating the grants that are available for rebuilding Nepal from the international donations of \$4.4 billion and \$2.2 billion in loan. In the Earthquake 31 out of the 75 districts were affected. The main focus of the NRA, HRRP and NGOs are the 14 districts that have been hit hardest by the earthquake. (Central Department of Population Studies, 2015)

The government of Nepal has stated that it is mandatory for an NGO to work with a local NGO or partner who are called implementation partners. Figure 83 below shows the organisation of the current earthquake recovery. It is first split into the 14 districts hit by the Earthquake, which are subdivided into partner organisations acting in the districts. The dendrogram then shows how partner organisations are organised in partnerships with implementing organisations. The dendrogram has been altered to be able to see the district in which the SSN pilot building was built-Sindhupalchok.

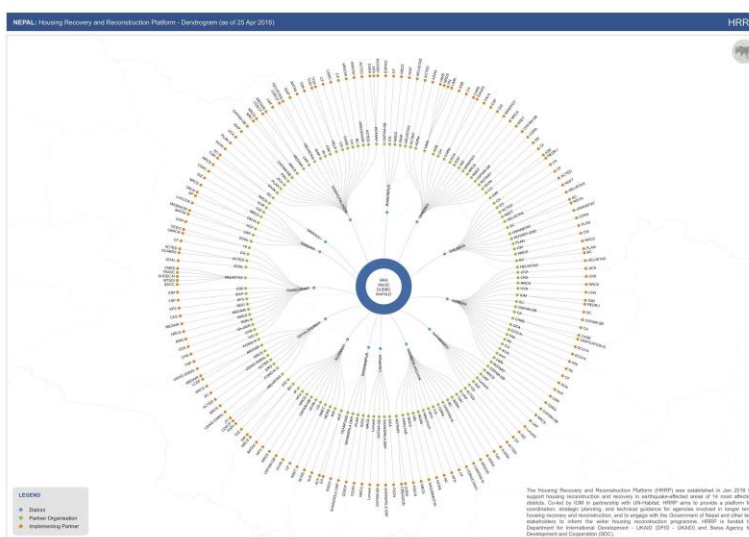

Figure 83: Stakeholders involved in rebuilding Nepal on different levels (HRRP, 2016). Extensive diagram can be found in Appendix II.A

## 14.6.2 NGOs active in and responsible for districts

The map below in Figure 84 shows the presence of implementing partners of the HRRP in 10 of 14 of the most affected districts post-earthquake 2015. They have been assigned to a certain district (or area) by the NRA. However, this does not always mean that they are responsible for the entire district. The pilot village of Ratankot

is located in Sindhupalchok (IOM is the district coordination team but there is no contact between the village of Ratankot and IOM). Habitat for Humanity is active in rebuilding and giving technical assistance in Kavrepalchok south of it and this is where their village of Pipaltar is located that was visited by team 5 and team 6.



Figure 84: District coordination team (HRRP, 2017)

NGOs are responsible for technical assistance and certain NGOs can also give out funds as grants for people to build up their homes with. The first grant is for \$500, the second for \$1500 and the third is for \$1000. (Appendix II.B)

As can be seen on the map below in Figure 85 that are different regional NRA offices. There is an NRA sub-regional office in Sindhupalchok. There is also a special contact office. Sub-regional presence of the NRA is to coordinate recovery and reconstruction related activities in the 14 most affected districts.

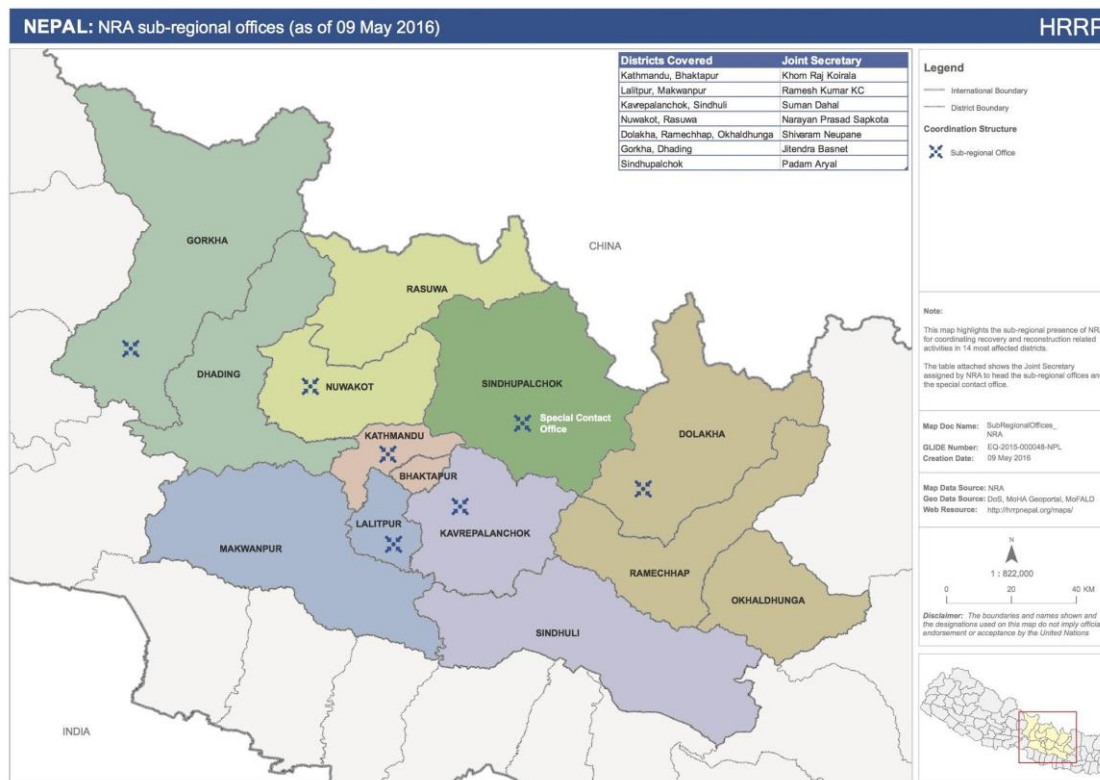

Figure 85: NRA sub-regional offices (HRRP, 2017)

## 14.7 Ethics

### Ethics and tradition

Norms and values between the Western world and Nepal differ, as there are cross-cultural differences as stated in paragraph 14.1. In the country itself the norms and values differ. Nepal is split up in the northern band, the middle band and the southern band. The elevations also differ between these bands. The North is connected to China and mainly Buddhist and the South is connected to India and more Hindu. (HRRP, 2017) Therefore, it is of great importance for organisations to take those norms and values into account when designing a house. The house has to be to their wishes, as their norms, values and tradition has to be

respected for the locals to build the house and live in it. For example, the building tradition in the north is for example dry stone. When designing a house for the north, that tradition needs to be respected.

### 14.7.1 Ethics and disaster management

NGOs are the main actors that are in charge of the disaster management regarding building houses. They are the actors that have to cope with the ethical questions that arise. Codes of Conduct are guidelines for organisations in order to regulate responsibility. These codes of conduct expresses norms and values and consists of obligations, norms and duties. (Van de Poel & Royackers, 2011)



### 14.7.2 Ethics and SSN

We as Shock Safe Nepal also have to take the ethical aspects that arise with researching earthquake resilient building into account. The question that comes up is whether the focus should be on the high quality of the house, or building as many houses as possible because the Nepalese still do not have sufficient shelter. Being a research group the focus lays on high quality of the house. However, the houses should be rebuilt within a certain amount of time after the earthquake. Where is the border and where should you draw the line? What is ethical responsible -to optimise the house more or get approval for the design so that inhabitants of Nepal can use our design for rebuilding?

Another ethical question is; How should SSN deal with the cross-cultural differences and the demands in an ethical manner? Knowing SSN a Western background and norms and values are completely different than in Nepal. In order to do this correctly, full understanding of the social and ethical aspects of rebuilding, being transparent and communicating with the locals themselves about their needs and wishes is essential in this matter. Only then we can create a successful product.

### 14.8 Barriers & Opportunities

The diagram below (Figure 86) shows the direct and indirect barriers and opportunities for building in Nepal. This diagram is based on

#### BARRIERS & OPPORTUNITIES

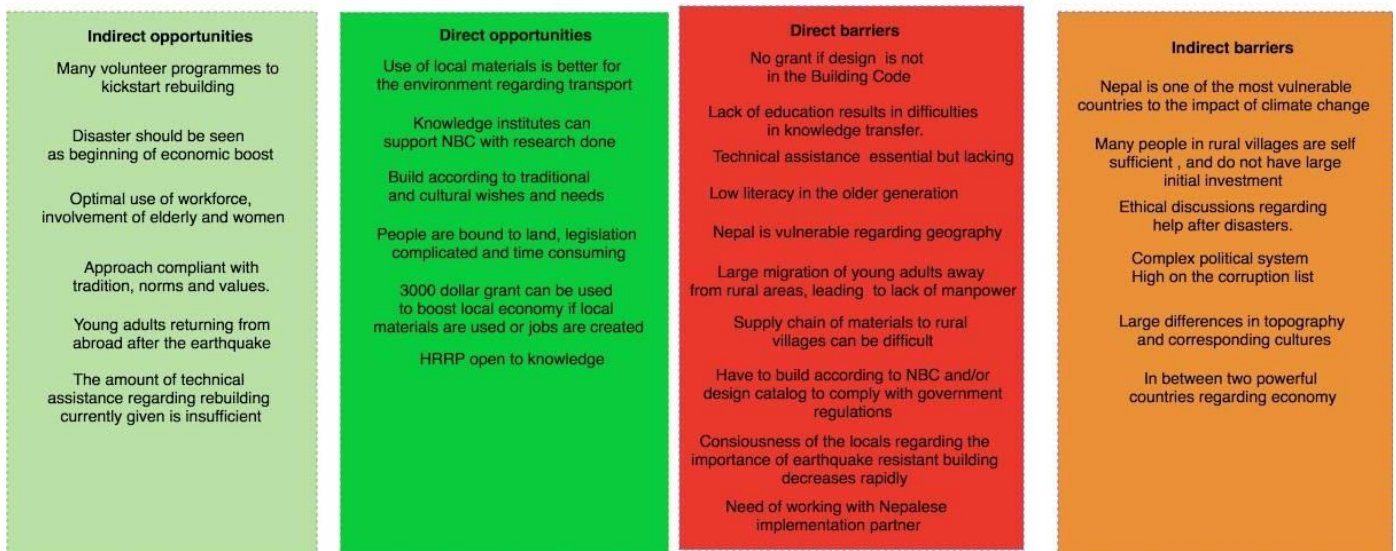

Figure 86: Barriers & Opportunities from external factor analysis



## 14.9 Conclusion

The external factors create extreme boundaries for SSN. Nepal and The Netherlands have many cross-cultural differences which have to be considered when building earthquake resilient houses. Most important, the building traditions are different compared to The Netherlands. The Dutch building method cannot be applied without any consequences. In addition, as Nepal is located in between China and India, even in the small country itself the building traditions differ from the north to the south towards the traditions of the countries located next to it. The social and ethical aspects have to be respected, otherwise the houses will not even be build and lived in - Nepal has complicated social structures. When the inhabitants agree on the social aspects of building, they have to be assisted technically. The focus has to be on the knowledge transfer and also check-ups. When knowledge is transferred by NGOs, the locals can transfer the knowledge further, taken the lack of education and literacy in account. It also has to be taken in account that there is a lack of manpower in the building process, on both technical assistance and the building itself. Building earthquake resistant housing by locals can be beneficial for the local economy. However, the government grants are essential for rebuilding. In order to receive the grants, designs have to be approved by the government. This will be the case if the designs are in the Design Catalog or if the design is following the NBC. This process is complex, time-consuming and costs a lot of energy. It has to be said that Nepal is one of the most fragile countries concerning environmental aspects. Last, regarding transport and infrastructure, it is important to remember that due to Nepal's geographic location makes Nepal a difficult country to build in.

# 15 Implementation Methods

*From Funding to Building: How implementations of building works.*

There are different actors involved in rebuilding and they have different strategies. There are NGOs that work from Nepal and are seen as implementing partners, they are

legally Nepalese which means that they are allowed to build. If an NGO is an INGO and not legally Nepalese, they need to work through one of the Nepalese organisations. This is so that more of the money that is donated goes to people in Nepal. In the following chapter case studies for different implementation methods will be analysed. After this it will be explored what the role of SSN will be between different stakeholders and how the design of the house can be disseminated through existing or new channels.

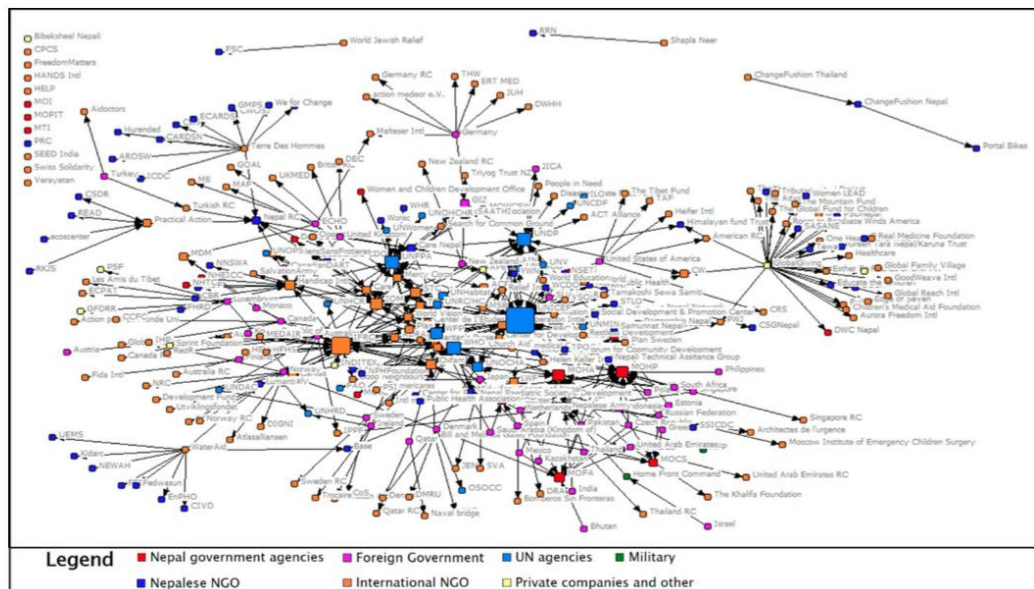

Fig. 1. Inter-organizational Network during the Emergency Response to the 2015 Nepal Earthquake.

Figure 87: Analysing the National Disaster Response Framework and Interorganizational Network of the 2015 Nepal/Gorkha Earthquake 9. (Bisri & Beniya, 2016)

In the implementation methods, the key aspects that will be looked at are if they are either a **partner organisation** (of the governmental organisations) or an **implementation partner**, community involvement, the number of houses they have (helped) build, who they are funded by and in which areas they are active.

Interviews with the organisations can be found in Appendix II.B

The reason that this analysis of current implementation is conducted is that it will be used to further analyse the possibilities of SSN and can aid in creating a strategy for SSN.

The implementation methods that have been analysed are of the following organisations:

- Habitat for Humanity (INGO, partner organisation)
- Architecture sans Frontieres (INGO, technological knowledge based Implementation partner)
- Build Up Nepal (NGO, innovative implementation partner)
- University of Tribhuvan (knowledge institute/university)
- HRRP (national information platform)

After the implementation methods, a SWOT analysis is developed per organisation to separate the strengths, the weaknesses, the opportunities and the threats, which gives a clear overview by which the organisations can be compared. This is done to gain insights into the current implementation strategies. This analysis forms the base for a feasible, sustainable implementation strategy for SSN in the long-term.

## 15.2 Habitat for humanity

INGO, Partner Organisation

### 15.2.1 Strategy

Habitat for Humanity's approach consists of activities that fall under the 4-pillars that define Habitat's programme. These form an approach to long-term recovery of earthquake-affected households and help rebuild communities that are vulnerable to be disaster resilient. The four pillars are; social mobilisation, technical assistance, tiered assistance and market development.

Figure 88 shows the four-pillar approach. Social mobilisation consists of the way in which they work together with the community. Technical assistance is given through trainings and in the HSSC, where 'TOT for mason' stands for Training of Trainers for Mason. Tiered assistance' regards funding of housing, this is given through grants and GIK. The latter stands for Gift in Kind which are charitable donations, products or services that assist in the home-building process, such as lumber, drywall, windows, but also hardhats or work boots. Lastly, they work on market development, which creates economic sustainability is created. (Habitat for Humanity, 2017)



Figure 88: The four-pillar approach used by Habitat for Humanity. (Habitat for Humanity, 2017)

They have also supported the government's enrolment process by providing staff and other resources that were needed in the enlisting of households that are eligible for the grants from the government. Habitat Nepal makes use of Housing Support Service Centres (HSSCs). There is one in each of the three VDCs where we are working. The Centres serve as a hub that people can come to get technical advice on house designs, information about the

building codes and NRA's guidelines to families to want to receive grants for building new homes. Habitat for Humanity is a partner organisation and works with other organisations to do the implementation, such as Architecture sans Frontieres (ASF) and Partnership for Sustainable Development (PSD). They are funded through Habitat for Humanity in other countries.

### 15.2.2 Areas

Habitat for Humanity is an NGO that currently works in over 60 countries (Habitat for Humanity, 2016). In Nepal they are active in 3 areas in two districts, these are wards 1 to 5 of Panchkhal VDC, Kavreplanachowk district, wards 1 to 9 of Salme VDC, Nuwakot district, wards 6 and 8 of Tupche VDC, Nuwakot district. In Kavrepalchowk they are supporting the rebuilding of 87 permanent homes in the village Pipaltar in Kavrepalanchowk district in which all houses, except for two, were destroyed. These houses were completed in March 2017. In areas Habitat for Humanity was responsible for rebuilding.

### 15.2.3 Community Involvement - PASSA

The approach that Habitat for Humanity uses in working with communities is the Participatory Approach for Safe Shelter Awareness (PASSA). Community groups called PASSA groups are formed in all Habitat Nepal project areas and are central to their holistic approach to preparing communities to work effectively together, manage reconstruction in their community successfully and to be prepared for future disasters. PASSA is an approach that was

developed by the International Federation of Red Cross and Red Crescent Societies. It uses a step by step methodology with three complementary processes. The first step is supporting community-led and socially inclusive development activities. The second step is enabling communities to identify their own realistic strategies to work on the different problems they face. This includes environmental and spatial planning; how effective local building techniques are and local building culture. The third step is creating partnerships between communities, local authorities and supporting organisations (IFRC, 2011).

Participatory activities through which participants of PASSA group do the following progressively:

- Develop their awareness of shelter safety issues in their community
- Identify hazards and vulnerabilities that create risk related to shelter
- Recognise and analyse causes of shelter vulnerability, identify and prioritise potential strategies to improve shelter safety
- Plan to put those shelter safety strategies into place, based on local capacities
- Monitor and evaluate progress.

## 15.2.4 SWOT of Habitat for Humanity

	<i>Positive Factors</i>	<i>Negative Factors</i>
<i>I n t e r n a l</i>	<p><b>Strengths:</b></p> <ul style="list-style-type: none"> <li>- Have been active in Nepal since before the Earthquake and have a lot of experience in the country</li> <li>- Have a large team</li> <li>- Have a technical team</li> <li>- The technical team is mostly out in the field and in close contact with the people who need the technical assistance</li> <li>- Are funded from Habitat for Humanity in other countries</li> <li>- Incentives and support to through microfinance organisation to low income families-was a new concept</li> <li>- See shelters as a pathway to permanence and out of poverty</li> </ul>	<p><b>Weaknesses:</b></p> <ul style="list-style-type: none"> <li>- Outsource part of the structural calculations</li> <li>- Government can be difficult to work with and is not enabling for INGOs, time is wasted and therefore money.</li> <li>- Have institutional donors with which everything gets more complex as they have their own regulations regarding what can and cannot be funded and</li> <li>- Sponsors want more restrictions and guidelines. Becomes complicates. Don't want to give shelter response but want to have defined how many people, houses have been built.</li> </ul>
<i>E x t e r n a l</i>	<p><b>Opportunities:</b></p> <ul style="list-style-type: none"> <li>- Use of international and national volunteers to kick-start projects in new villages</li> <li>- New building code being published</li> </ul>	<p><b>Threats:</b></p> <ul style="list-style-type: none"> <li>- Government restrictions and lack of political will</li> <li>- Funding stopping as building does not go as communicated before with donors.</li> <li>- Emphasis of quantity over quality in the past</li> </ul>



## 15.3 Architecture sans Frontières

*Technical based implementation partner*

### 15.3.1 Strategy

Architecture sans Frontières (ASF) Nepal aims to support sustainable development of disadvantaged communities in Nepal by sharing technical and scientific expertise with people. They are an NGO that is based on the voluntary work of professionals and students that work in engineering, architecture and the built environment (Architecture Sans Frontières International, 2017). Their focus is on strengthening existing technologies and buildings.

ASF in Nepal started off as a knowledge organisation (Ingenieurs sans Frontières) but extended their work field after the 2105 earthquake when it became clear that how essential it was that dissemination of knowledge was closely tied to the implementation. They clearly state that **they** do not build. However, they construct demo house, train masons after which the local people build. They follow the government rule and use an owner driver approach and PASSA. They have 7-10 people who were trained to use the **PASSA method** (Appendix II.B) and this approach is used when working for Habitat for Humanity. (Sangachhe & Shrestha, 2017)

*“We don’t care about other technologies. We care more about what is available here. For example, you can give your grandfather an iPhone 7, but if he doesn’t use the iPhone in the way it’s supposed to work, there is no point of your grandfather having an iPhone 7.” (Appendix II.B)*

### 15.3.2 Areas

ASF is active in multiple districts. They are currently an **implementation partner** for Habitat for Humanity and other partner organisations; this means that they work in the districts that these partner organisations have been appointed to. They have for example built 15 houses in Dolakha, have 250 beneficiaries in Panchkal and in total there are around 5000 houses spread through 5 districts that get technical support and advice from them.

### 15.3.3 Community involvement

In 3 out of the 5 districts ASF is applying Local Building Culture principles. This focuses on that buildings should possess all cultural aspects that they did previously. Looks should be similar and the space organisation should be similar. Storage is an important example as people need the storage for the way they live, and their dietary habits. There are examples of people who, with the shelter tunnel houses kept the rice in the shelter instead of living in them. They would live under tarpaulin. (Sangachhe & Shrestha, 2017). Not everyone in a village is involved in building but ASF tries to create local businesses around rebuilding.

### 15.3.4 SWOT of ASF

	<i>Positive Factors</i>	<i>Negative Factors</i>
I n t e r n a l	<p><b>Strengths:</b></p> <ul style="list-style-type: none"> <li>- Most people working at ASF have studied at the university in Kathmandu.</li> <li>-Only good in social and technical –also social- market development implementing livelihoods</li> <li>- ASF has a network in 40 countries</li> <li>-Have a large number of international partners</li> <li>-After earthquake registered as ASF in National Government.</li> <li>-Have an office and permanent staff now</li> <li>- After the earthquake, they received large amounts of money.</li> <li>-They have 2 million euros for projects for 3 years.</li> <li>- Has 7 offices currently and 20 staff</li> <li>-Receive in-house training ARUP</li> </ul>	<p><b>Weaknesses:</b></p> <ul style="list-style-type: none"> <li>- Can't keep growing unless they have partners to work with</li> <li>- Need to update building codes- DUDBC they know which wrong / don't have expertise to improve.</li> <li>- When students come from university they have learned about building with concrete and multi-storey housing. However, they are not as experienced in building with stone mud mortar. Lot of in-house training required.</li> <li>- They are a relatively new organisation and are still learning, lots of expertise is needed and the capacity of staff has to be developed.</li> </ul>
E x t e r n a l	<p><b>Opportunities:</b></p> <ul style="list-style-type: none"> <li>-Studying and helping the government with improving the building code and technical assistance.</li> <li>-Have been in contact with the DUDBC, and can work together.</li> <li>-Funding as a one to one model costs 10000\$</li> <li>-Making a shake table here, in Nepal. Test traditional wooden corner bands with the table. Preferably at a university than private/government organisations. Planning to connect all universities in earthquake technologies. Pakistan has a shake table that can be seen as an example             <ul style="list-style-type: none"> <li>-Digital Imaging on a shake table test- 600s in 1 sec. film and analysing the impact of earthquakes. Has numerical test after. Very good assessment.</li> </ul> </li> <li>- Revising the building code</li> <li>-Design Catalog 1st is not relevant to the field- use of steel that is not always available. Improvements can be made on the design Catalog. Example are traditional roofs that hang over the walls to protect from rain which are not in a single design in the code.</li> </ul>	<p><b>Threats:</b></p> <ul style="list-style-type: none"> <li>-Nobody to monitor protocols – not given much importance.</li> </ul>

## 15.4 Build Up Nepal

*Innovative implementation partner*

### 15.4.1 Strategy

Build up Nepal is involved in rebuilding of one house in every village that they work in. They are an implementing partner that works for other NGOs. They "believe the best way to rebuild Nepal is by empowering local people and using local materials. Together with INGOs and NGOs we provide machines and training for rural communities, teaching them to make Earth bricks (CSEB) and rebuild their own village." They have so far built 38 houses and there are 50 under construction. They have built six schools, a preschool library, a community centre, an agricultural collection centre, and a health post. They have technical experts that focus on working beyond building a building but building a village. They collaborate with other organisations & villages to implement the building and provide long term support. Do not want to build the houses for locals but want to help get started & promote local entrepreneurs and through that on the more deeply rooted issues & challenges that can be solved through housing. (Appendix II.B)

Build Up Nepal is an **implementation partner** for organisations working in Nepal. They use an **innovative building method** not traditional building methods. The use of CSEB is currently not in the NBC. Therefore, the houses that have been built so far have **not been built with the government grant** but have been funded by organisations.

### 15.4.2 Areas

Build up Nepal goes where their clients want them to go. They are active in all earthquake hit areas. Before starting they make a feasibility assessment, if you have to walk for more than two hours to the location it is generally not feasible as sand is needed for CSEB. Being able to transport the sand is essential. The higher mountain area is not feasible although there is one exception of a village at 12,700 where they have a deal with a rescue helicopter that transports sand. If the location, it near the (dirt) road or near a river it is possible as sand is available. Earth Bricks will be expensive but everything else would be much more expensive. There have been two villages where building using this method has been found to be unfeasible.

### 15.4.3 Community Involvement

Build Up Nepal believes in educating the community to create more sustainability and extend the positive impact of rebuilding. They focus on community driven reconstruction and supporting local entrepreneurs.

## 15.4.4 SWOT of Build Up Nepal

	<i>Positive Factors</i>	<i>Negative Factors</i>
<i>I n t e r n a l</i>	<p><b>Strengths:</b></p> <ul style="list-style-type: none"> <li>-Methods are tested a lot of places and they have found what works. Have found a process of convincing local community. Done in lot of places. learnt from all the challenges.</li> <li>- Cheap machines are bought in India</li> <li>- Model is works extremely well in Nepal</li> <li>-High demand, the need for housing is large but knowledge about getting it done is not.</li> <li>-They have a great team that is capable of getting it done.</li> <li>- Build on local capacity and local people.</li> <li>-Nepalese company and international companies are required to work together with local NGOs, Build Up Nepal is a local NGO that is trustworthy.</li> </ul>	<p><b>Weaknesses:</b></p> <ul style="list-style-type: none"> <li>- Meeting the demand (already, while the Design Catalog has not yet been published)</li> <li>- Have been relying on what other people have done for structural calculations (Oroville institute) - have submitted calculations. Whatever we do they can do it better. They have the guidelines.</li> <li>-The Design Catalog Is the barrier at the moment (they are confident that it is coming soon). The interlocking compressed earth bricks are not in the building code, and the designs of housing are currently not in the Building Catalog.</li> <li>- As long as they have people on site it's not difficult. But difficult to maintain quality without. Sometimes for example the team changes or the building design changes or suddenly less rebar's are used.</li> <li>-Interesting example of the risk in the image of a building method- hollow concrete blocks are a good technology but because of malpractice in Nepal there is no trust for the bricks anymore. They are used in other places and strong but the quality of materials used in the bricks here became of lower and lower cost and when one project that fails means that the blocks fail.</li> <li>-They do not don't believe in entrepreneurs themselves testing the bricks. If the community knows how to test the brick it would improve the trust and therefore there is a need to empower the people to test it themselves.</li> </ul>
<i>E x t e r n a l</i>	<p><b>Opportunities:</b></p> <ul style="list-style-type: none"> <li>-Creation of cheap testing methods for buyers of the bricks, to maintain quality.</li> <li>-To get building designs with the use of CSEB bricks Design Catalog</li> </ul>	<p><b>Threats:</b></p> <ul style="list-style-type: none"> <li>-Bricks failing in one place would mean trust in all bricks decreases/disappears</li> <li>- Government restrictions and lack of political will</li> </ul>

Figure 89: SWOT of Build Up Nepal

## 15.5 University of Tribhuvan

*Knowledge Institute/University*

### 15.5.1 Strategy

University of Tribhuvan is a knowledge institute, not an implementation partner or partner organisation. They educate people who end up working in the field and work with the NRA and HRRP on technical assistance. They are not directly funded to help with rebuilding but do offer their expertise and knowledge to (government) organisations. One professor of our faculty is a member of the NRA.

### 15.5.2 Community Involvement

The university of Tribhuvan does not use specific approaches to work with the community in areas where they do research.

### 15.5.3 Areas

The Tribhuvan campus is the central engineering campus, one in Pokhara and one in Dhrar provincial and Thabo Theli in Kathmandu ten affiliated private colleges. They follow their curricular. The university plays an advisory role in areas where the NRA asks them to.

### 15.5.4 SWOT of Tribhuvan University

	<i>Positive Factors</i>	<i>Negative Factors</i>
<i>I n t e r n a l</i>	<p><b>Strengths:</b></p> <ul style="list-style-type: none"> <li>-Have testing facilities for structure testing</li> <li>-Tribhuvan has played very important role in damage assessment and in categorising the damage.</li> <li>-Giving new designs to the government</li> <li>-Everything we do the research here</li> <li>-Awareness of the problems in Nepal</li> <li>-Have a lot of knowledge</li> <li>-All engineers of the NRA studied here are a product of this university, they are therefore close to government</li> <li>-Professors are passionately involved in earthquake resistant building and put their free time into it</li> </ul>	<p><b>Weaknesses:</b></p> <ul style="list-style-type: none"> <li>-Do not have the internal structure to set up earthquake programmes</li> <li>-Do not have the funding to set up earthquake programmes</li> <li>-Most affected villages- buildings by villagers themselves- they have not used engineering knowledge.</li> <li>-Stone masonry, where to put timber, how to make walls strong</li> <li>-Teachers are involved in training masons- we cannot train people in the village, but we can bring them here and then we train them, we give training as expert.</li> <li>-They cannot go out into the field all the time, their primary job is at the university, but in their spare time professors give training. Other INGO/org organise the training. We go as expert.</li> <li>-A lot of opportunities but right not taking every university- we have semester system and very tight schedule. When class starts, we have no spare time, then exam and classes start.</li> </ul>
<i>E x t e r n a l</i>	<p><b>Opportunities:</b></p> <ul style="list-style-type: none"> <li>-Contact with implementing partners</li> <li>-Hosting more international students in testing and learning from other countries</li> <li>-Final year students as supervisors for buildings</li> </ul>	<p><b>Threats:</b></p> <ul style="list-style-type: none"> <li>-Not enough funding</li> </ul>



## 15.6 HRRP

*National Knowledge Institute*

### 15.6.1 Strategy

HRRP acts as a platform between the NRA and government and all other stakeholders involved in rebuilding. They do not build any houses themselves but have a large influence on organisations that do. They do research in the field into needs and have teams in all 14 earthquake affected districts. They support the NRA in the owner driven approach. The platform is focussed on coordination of reconstructions, following up on the governmental and identifying issues so they can be resolved.

HRRP is an organisation that can be interesting in the dissemination of the design of SSN. They have contact with many of the organisations working in Nepal and they can share information about designs or research with them. Organisations interested in the

research of SSN can then get into contact with SSN

### 15.6.2 Areas

HRRP works around the 14 districts that have been hardest hit by the earthquake. They are planning on going into the other 17 districts in the future. They are working on a survey that is 60-70 % complete, this regards the needs of people in terms of earthquake relief and need of rebuilding. They have one team for Kathmandu valley district.

### 15.6.3 Community Involvement

HRRP maps the needs for earthquake related recovery throughout Nepal, they do not have certain methods of working together with the local communities as they are not directly rebuilding with the communities. They strongly believe in the owner driven approach set up by the government.

## 15.6.4 SWOT of HRRP

	<i>Positive Factors</i>	<i>Negative Factors</i>
<i>I n t e r n a l</i>	<p><b>Strengths:</b></p> <ul style="list-style-type: none"> <li>-Strong relationship with the government, partner organisations and stakeholders involved in rebuilding Nepal.</li> <li>-Have district teams for all 14 districts, people in the field</li> <li>- Sharing of Governments information in ways that NGOs can grasp and implement</li> <li>-Service to organisations</li> <li>-Help organisations to implement government guideline as there can be huge confusion about assessment.</li> <li>-Understand what they can and can't do.</li> <li>- Act as a platform for questions and answers</li> <li>-Questions from households</li> <li>- Strongly involved in information sharing</li> <li>-Gathering and dispersing organisations throughout the country</li> </ul>	<p><b>Weaknesses:</b></p> <ul style="list-style-type: none"> <li>-High dependence on the government.</li> <li>-Being seen as a go-between for organisations takes more time than linking organisations.</li> <li>-Lack of knowledge in the field, have to educate and reach a large number of people</li> </ul>
<i>E x t e r n a l</i>	<p><b>Opportunities:</b></p> <ul style="list-style-type: none"> <li>-Biggest one with poor technical assistance high levels of non-compliance.</li> <li>-Operationalising technically retrofitting grants</li> <li>-Engineers go to houses all done physically</li> <li>-Increasing the Inspection process, which has just started but is going well now.</li> <li>-Strengthening traditional houses, code &amp; inspection does not cover that type of housing.</li> </ul>	<p><b>Threats:</b></p> <ul style="list-style-type: none"> <li>-NGOs starting rebuilding without following guidelines, high noncompliance</li> <li>- Some households are moving quickly and cannot be penalised when they are done but this is difficult to see after it has been constructed</li> </ul>

## 15.7 Conclusion

Every partner has their own implementation method and their own vision on how to implement with the greatest impact and largest efficiency. From the previous SWOT analyses these differences become clear. Between organisations working in the field there is a difference in focus on quantity (as much shelter as possible) vs. quality (sustainability), education (teach how to) vs. implementation (build themselves), amount and type of partners to collaborate with.

The impact of the projects of the five organisations differ as well, in terms of long-term impact. The knowledge about current implementation methods is guiding in the focus of the following chapters. Later in this report, in the long-term plan, the implementation method and strategy for SSN will be developed.



# PART VI. RISK ASSESSMENT





# 16 Risk

## Assessment

When designing the house, the main goal is for it to be earthquake resilient. Therefore, a design is necessary which can be constructed according to the building methods. However, building a house in a Western country is different than building in a country such as Nepal. Differences in social standards, traditions, the needs and wishes, government's regulations, but also external control and labour availability have to be considered. External factors can lead to a high-risk project.

An example of this is the pilot building in Ratankot. A house was promised to the locals, but due to lack of time this house has not been optimally calculated and validated beforehand. The result is that it is not allowed for the people to live in the house. After interviewing the locals, the outcome was surprising. The locals were impressed by the house; however, they were not fully convinced to want to live in the house; the roof is too high, storage in the roof is lacking, there is no room for animals and two separate rooms is not ideal for a family to live in. There are lessons to be learned in this example, but what is the cause of those risks and which factors have to be looked at critically to make the project successful in the future?

Therefore, risk assessment is an important aspect in project management, especially in a project such as Shock Safe Nepal. Culture differences play a large role in success as well as knowing how to construct earthquake resilient building. The outcome of the risk assessment is a risk strategy in how to cope with possible risks.

The following framework will be used for the risk assessment. First, the risks will be identified. Second, the risks will be assessed by determining the probability, impact, consequences and priority. Third, after the identification and assessment, risk response

will be set up through strategy to treat the risks by transferring, avoiding, reducing or accepting. This process is also to be seen in Figure 90 below. The extensive risk analysis can be found in Appendix II.C

**Risk Process**

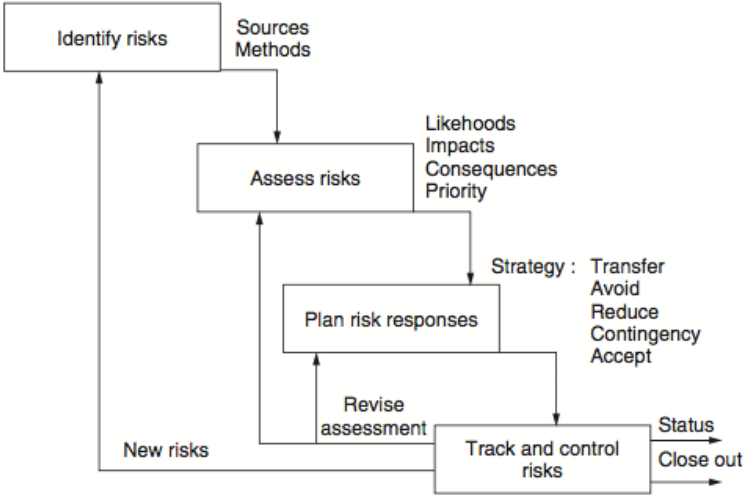

Figure 90: Risk management elements and process. (Nicholas & Steyn, 2012, p.352)

## 16.1 Identify risks

The risks are divided into three types, which are broken down in components, the affected elements, the failure mode, the cause and the consequence. The three types of risks are external risks (E), design risks (D) and construction risks (C). The components and elements of external risks are physical environment regarding location, consumer needs and wishes, costs regarding the price of the house, government's regulations regarding the NBC and Design Catalog, labour availability regarding manpower and external control regarding technical assistance. (Nicholas & Steyn, 2012). The components of the design risks and construction risks are the used materials of the pilot house in Ratankot. The elements of design risks are divided into structural and secondary elements and the elements of the construction risks are divided into the used materials bamboo, bricks and concrete. To give a clearer overview of this, a decomposition of the house is shown below in Figure 91.



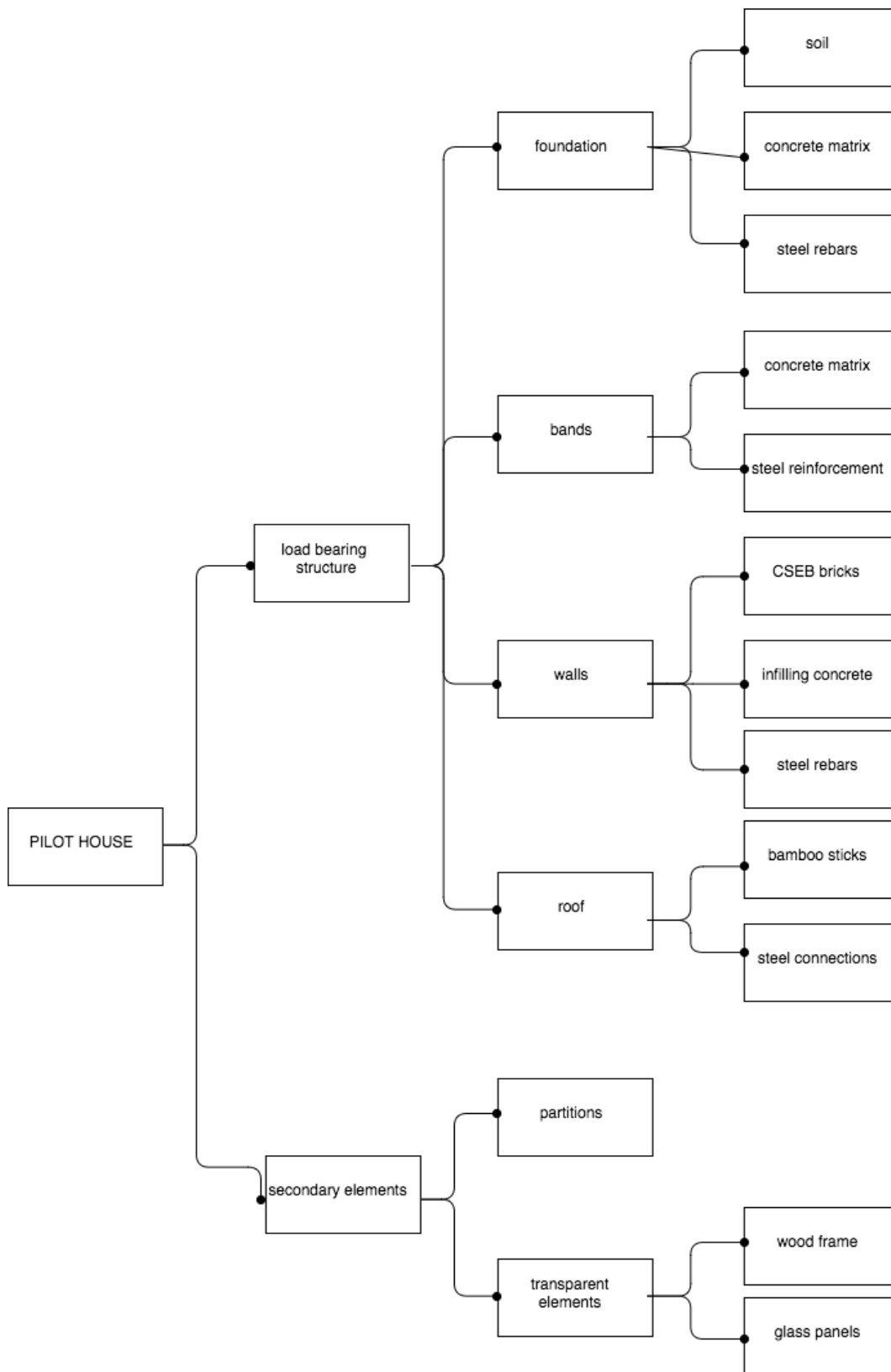

Figure 91: Decomposition of pilot house in Ratankot

### **External risks**

E1: If the house is built on either a landslide or a slope more than 20%, due to the environment, the house is not safe.

E2: If the house is not according to the needs and wishes of the consumer by mistake of the designer, the house will not be lived in

E3: If the house is unaffordable or consumers are not willing to pay, due to materials, unmanageable supply chain, lack of manpower or too expensive, then it is not possible to build the house. Therefore, funding is essential.

E4: If the house is not build according to the NBC and/or Design Catalog, the design will not be accepted by the government and no grants will be given.

E5: If there is not enough manpower to build the house, due to too little or non-educated workforces, it will result in a low performance building

E6: If there is no technical assistance, due to lack of management and capacity, then the house will probably not be build according to the earthquake resilient design, see '*construction risks by the locals*'.

### **Design risks by technicians**

D1, D2, D3: If the dimensions of the cross section of the elements are not right, and/or if the connections between the structural elements are poor, and/or if the reinforcement is insufficient, then the structural performance will be low. This is due to lack of knowledge and thus lack of

technical assistance and money as well, as alternative methods will be found to be cheaper.

D4: If the wrong type of material is used, such as bamboo and steel, the structural performance will be low. Furthermore, some materials are not socially accepted and there is a chance this material is not in the NBC or Design Catalog, which means that the design will not be accepted and there will be no funding.

D5: If the quality of the material is low, meaning the components of the material, then the structural performance will be low as well, due to lack of technical assistance by choosing the material

D6: The secondary elements do not contain high risks.

### **Construction risks by the locals**

C1: Treatment of bamboo is essential. If the bamboo is wrongly treated, or not treated at all, then the structural performance will be low. This can be due to lack of knowledge and thus technical assistance, effort of the constructors, no money for the treatment and time.

C2: Bamboo will be exposed to external conditions which damages the material. This happens when the bamboo is not or wrongly treated.

C3: If a different type of bamboo is chosen, because the assigned type is not locally available and it is too expensive and time-consuming to obtain the right type of bamboo, the weight and dimensions of the material will be different which affects the structural performance.

C4: Lack of knowledge about construction will result in low structural performance as well. This is due to the lack of technical assistance and could be effort of the constructors as well.

C5: The durability of bamboo depends on the environment and time and whether the bamboo is treated right. It will damage the bamboo and thus will not be structurally safe.

C6: Low quality of the bricks can be caused by lack of the CSEB machine and lack of knowledge, because constructors do not know how to make the bricks properly or are not able to. Money can be an aspect as well, as CSEB bricks of different quality might be available elsewhere. This is all due to lack of technical assistance.

C7: Lack of knowledge about construction results in low structural performance due to lack of technical assistance.

C8: The durability of the bricks depends on the environment and time and whether the bricks are produced right. It will damage the bricks and thus will not be structurally safe.

C9: If the mixture of the concrete is insufficient, then the structural performance will be low. This is due to lack of knowledge

and thus lack of technical assistance, but also the available tools, materials and money.

C10: Lack of knowledge about construction the house will not be built in a proper way which causes low structural performance, due to either effort of the constructors and/or technical assistance.

C11: The durability of the concrete depends on the environment and time and whether the mixture of the concrete is sufficient as well as the construction. It will damage the concrete and thus will not be structurally safe.

#### 16.1.1.1 Risk assessment

After the risks have been identified, the probability, impact and priority have been determined. An elaborated overview of the risk assessment is to be found in Appendix II.C. With the risk identification and risk assessment the risk response can be set up through strategies to treat the risks. According to DeLoach (2009), risks management strategies consists of the classic four; reduce, avoid, retain or transfer, as can be seen in Figure 92

## Risk management strategies

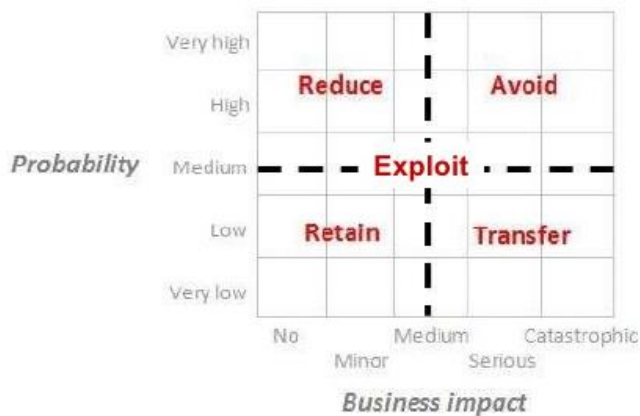

Figure 92: Risk Management Strategies. (De Loach, 2000)

High probability and high impact risks means that the risks are extremely critical and should be avoided. Low probability and high impact risks should be transferred, to reduce the impact of the events. High probability and low impact risks should be reduced, to reduce the likelihood of the events. Low probability and low impact risks are not as harmful and can be retained and thus accepted.

As to be seen in Appendix II.C, most of the risks have medium to high probability as well as impact, therefore many critical

components. In addition, most of the risks are dependent on each other. Based on the criticality of the risks, strategies will be chosen to reduce the risks to a certain level of acceptance. However, it should be considered that when being realistic, this is not always the case.

The outcome of the risks (probability \* impact) is shown in the charts per type of risk in Figure 93 below.

## Level of risk per failure mode

### External risks

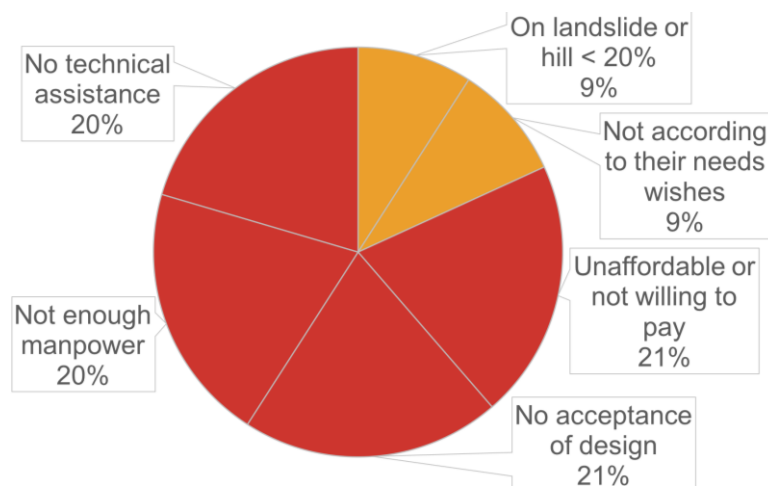

## Design risks

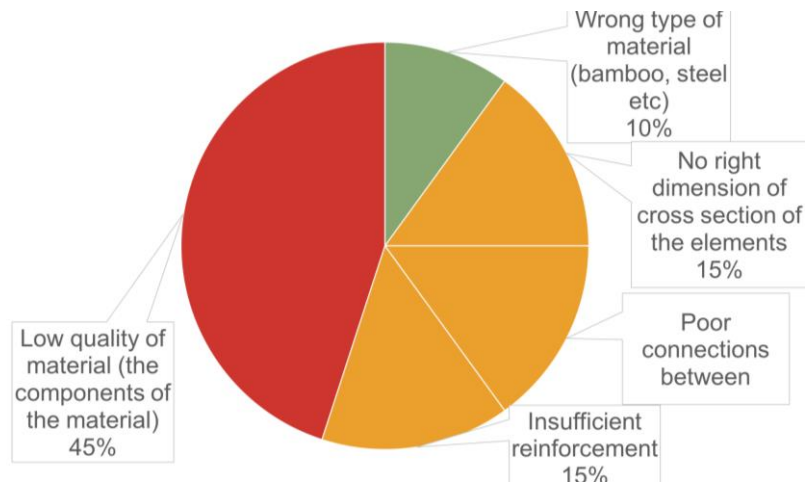

## Construction risks

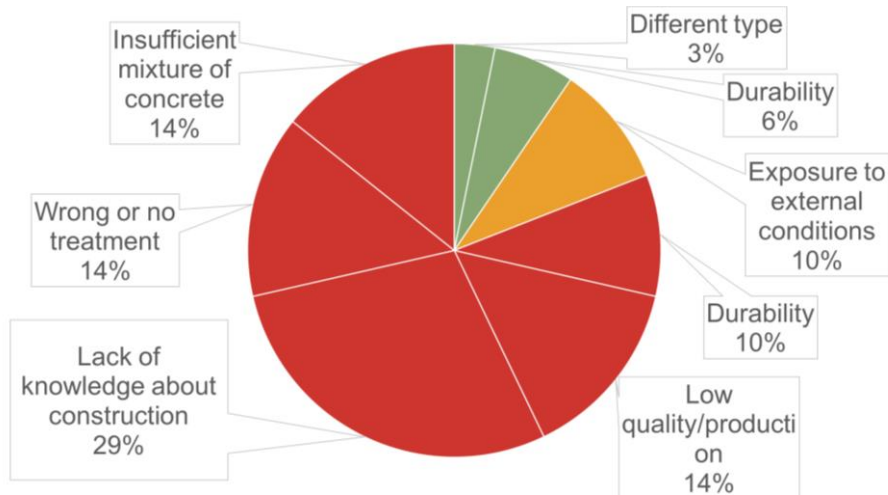

Figure 93 Charts with external risks, design risks and construction risks divided into levels per failure mode

## 16.2 Risk strategies

### 16.2.1 External risk strategy

E1: lands owners have a certain land availability in terms of dimension and quantity. The possibility to build buildings in sites different from those they already own means they should invest money to buy other lands, which is not possible due to the low money availability for villagers in a common situation as stated in §14.1. Then,

the owner must be warned by technicians about the risks linked to build a certain building in a certain area, depending on the characteristics of the field (soil composition, pendency, presence of obstacles, etc.). The decision to build or not to build is then transferred to the land owner depending on the state of his land and his needs. However, the feasibility of this approach is low as the owner is bound to the land, therefore the strategy is to retain the risk.

E2: The owner needs must be discussed with the subjects directly interested (the designers) in the construction of a certain

building. They could change situation by situation, even depending on the social aspects linked to them as stated in §14.1. For example, in the north building with dry stones is the tradition. It is up to the designers to analyse the requirements that must be included in a certain intervention. The risk can be reduced by discussing the dimensions, layout and size with the client, with respect to the current building codes that are valid in a certain area.

E3: The project must not exceed the budget fixed based on the money availability of the client. The risk can be avoided by designed according to the building code, because then grants will be given to the client to build the house. However, the design provided should be dependent on the needs of the client. The costs can be reduced using locally available materials, cutting costs linked to the transport of them but still without influencing the quality of the house, that must be above a certain level of safety and durability. Local workers permit to cut costs regarding the manpower, however, as seen in risk E6 this is not feasible.

E5, E6: There is too little manpower, due to the lack of knowledge about construction operations that is commonly visible in rural villages. Not to compromise on the final quality of the building, technical assistance in terms of supervision and/or training sessions provided by experts is generally required, to avoid the risk.

E6: In terms of earthquake safety level of the house, guidelines and recommendations are provided by the government. This can be achieved by external control through supervision and technical assistance.

E2-E6: As these risks have medium or high probability and impact, those risks should, and theoretically can, be avoided. However, in practice the feasibility of avoiding those risks is low. Due to the local lack of

knowledge about earthquake safety of buildings, the complexity of the subject and looking at the current situation of the country in terms of money availability and technical expertise, generally speaking, putting effort into providing innovative solutions that could be safer is not a suitable choice for because of the factors that follow:

the amount of money that would be required to get to a solution that would be safer than the one already provided by the government, in terms of studies and analysis that should be done beforehand and then about the design itself;

the risk no to get funding from the government for a certain intervention because the fact that recommendations provided by that have not been respected or the time and money that would be required to convince the governmental bodies that the solution offers a certain level of safety even not respecting the provided recommendations;

the lack of technicians that could provide a better solution and their compensation that should be paid by the clients themselves;

E4: Instead of providing an innovative design that is not included into the current building code, technical solutions that are already suggested by the government should be adopted to get funding to build houses. This gives the villagers the possibility to get money back linked to the construction of houses, but it stays valid only for solutions that are advised directly by the governmental bodies. In this phase, technical assistance as supervision is still required to control that the money provided by the government will be invested into the construction processes to get to a final quality result which is related to what has been accorded during the design stages.

### 16.2.2 Design risk strategy

D1+D2+D3: looking at the common practice that is current in the country, technicians



used to design temporary and permanent housing solutions according to the building code given by the government, without making actual calculations or analysis about the adopted solutions. This gives the high probability to the villagers to get funding when they have to build a house. During the design phase, the probability that guidelines given by the building code are not fulfilled becomes then low. The structural performance that is then get to be equal to the one described by the building codes themselves. It is not common that designers try to provide new solutions that could be earthquake safer or cheaper, because the risk for villagers not to get funding from the government could incur because the procedure to promote solutions that are not included into the building code through the governmental bodies requires time and money and it is not always appreciated.

The solutions adopted during the design phases have high impact on the final structural performance of the housing solution. However, common thinking for people, especially in the rural areas, is that when a house fulfils the requirements given by the building code it can be seen as earthquake safe, or at least it is already sufficient because it is the first requirements necessary to get funding, which is the heaviest factor for people who have limited money availability. However, recommendations inside the building code are still insufficient to get to solutions that can be seen as highly earthquake safe. This aspect could be made better and more complete improving the building code about the information that are inside that and the procedure and calculations necessary to promote different solutions, not to provide standardized solutions for local people but giving them the possibility to personalize them according to their needs and again in collaboration with technicians that would be able to approve and/or translate people's

needs into technical solutions. The probability that a design will not fulfill the guidelines given by the building code, in both the situation for an already-made or innovative solution is then low, or at least much lower than the impact that the construction processes of the same design could have on the final structural performance.

### 16.2.3 Construction Risk Strategy

C1+C2+C3+C5: bamboo has been already used in many cases as a building material as both partitions and structural elements, even it has not been included into the building code yet. This meant that the bamboo application visible so far did not follow guidelines given by the government, and, because people want to get funding from the government and this would not be ensured using materials that are not indicated by the building code, it has been used only for singular elements or limited parts of the houses. This is explained by the high availability of this material for certain areas and villages, making the costs to build a house lower and the construction time quicker thanks to the local accessibility of that. The material has been used, to ensure a certain structural and durability performance, the quality of the material must be known and treatment should be applied.

Firstly, because of the high dependency of the material properties on the nature and characteristics of the material itself, a certain knowledge about the nature of bamboo should be had by workers and villagers. The performance of bamboo as building element depend on the ages of the material and if and how it has been treated; these phases can be improved providing tools and knowledge to villagers with technical assistance and/or training session, to give them a rough but necessary knowledge about the processes that should be done, as how it should be cut, when, what is the most suitable treatment

that could be done looking at the local situation of the village and the money availability, checking the possibility to use gravity as pressure driving during the treatment, etc. Setting up a treatment centre for bamboo elements is from on hand expensive for the villagers but, on the other hand, can provide new jobs for local people and incomes selling the treated elements. Furthermore, it must be said that rough but still effective treatment of bamboo can be realized even with simple and cheap tools that can however improve the properties of the material considerably (e.g. Ratankot). However, this process would take long time, not only for the treatment itself but because villagers have no knowledge about this topic: to buy a treated bamboo stick instead of a non-treated-one, local people want to see the actual performance of the two compared to each other, which means that several years must be waited. Secondly, the point of view of technicians are needed to place bamboo in certain conditions that cannot be damaged by external factors, to avoid the risk that it should be replaced during its working service life. This depends on the specific situation that is analysed, as linked to the weather conditions, the presence of aggressive components nearby the elements and the boundary conditions as the contact with soil or damaging factors. The risk can be mitigated if not avoided even applying covers to protect the material from aggressive conditions, improving the durability performance of the material but paying attention to the covers materials as they should be aggressive for the bamboo sticks in contact with that and not toxic for the people that would live the house. Using bamboo is common when it is locally easily available for villagers; however, many types of bamboo are present in nature and their characteristics (and then performance) change type by type. A technical assistance about the quality of the bamboo, and the possibility to use that as a building material or not, should be then provided to the

villagers. However, this could mean that they should not build with locally available material (that means that is cheaper than others) but that they should buy money to get other types; this step would not be taken by villagers with high probability because of their lack of money availability. In this case, not to compromise the structural and durability performance of the housing solution, the material should be replaced with more suitable ones or at least treated as good as possible to improve their properties.



*Figure 94: bamboo treatment with borax and boric acid and using gravity as pressure driving*

C4: the common practice regarding the actual construction of bamboo structures, as the connections between sticks, is based on making the construction processes as easy as possible. No attention is paid to where and how the sticks should be connected, and many times other materials are added to bamboo elements to make the connections between elements more rigid, as wood for example. This can be explained by the fact that bamboo has a circular shape that makes the connections between the sticks more difficult. Furthermore, bamboo sticks should be connected far from the natural joints present into the material, because those are weak points talking about the structural performance, because of their inner chemical composition (see bamboo properties for more information); this step is not always considered because the lack of knowledge about this topic for the workers.

The shape of the structure should be modelled beforehand, and calculations should be made, firstly to check the actual structural stability of the elements and then to distribute the loads in the best way possible to the load bearing structure of the house. It is common practice using bamboo to build the roofs and partition elements, while the main structure is generally made of bricks and reinforced concrete elements. A technical point of view is needed to make the structure as safe and stable as possible, and then on site application and connection should follow the prescriptions given by technicians. However, the actual common practice is far from the just-mentioned one, where workers do not follow a specific design or, if they do that, they change the connection points to other that make the construction easier, but with the risk of compromising the structural performance of the bamboo structure. Training session should be organized to teach the workers how and where to connect the bamboo sticks with each other, and on-site supervision would be a perfect check the workers making the structure as it has been designed. A load distribution, both for the bamboo structure itself and then to transmit the forces to the load bearing structures, must be analysed, in order to create a whole structure which is equally loaded without weak points and not to overload certain elements locally. To avoid a wrong construction of bamboo structures, because of the natural complexity of the characteristics of the material itself and the complexity of the structural design, technical assistance in terms of teaching and supervising is needed.



*Figure 95: Insufficient structural connections*



*Figure 96: Insufficient structural connections*

C6: bricks are generally used to make the load bearing structure (walls) of the house in the common practice. When bricks are bought from bricks production companies, the quality is already checked during the production stages and the information given by the producers are assumed to be reliable, as regulated by the current norms. However, many villagers cannot afford to buy bricks directly from the producer and making bricks by themselves is a practice that is developing more and more, to cut costs for the materials. Many NGOs already provided machine to make bricks directly close to the site and to provide the possibility to get incomes if they are sold to other people. On the one hand, this helps the villagers to get money from what they produce by themselves and/or having close material which is suddenly utilisable when needed. On the other hand, because of the properties of the bricks depend on their composition and the material used into the mix, technical assistance should be provided to the

villagers to inform them if and what kind of locally-available materials they can use to get to a satisfactory final performance of the structural components. Bricks machines have been already provided by local NGOs to many villages as a source of income and for self-support, and this operation would be useful if not necessary for a lot more villages. This is not financed by the government; collecting money from NGOs and abroad organization is the only way to make it more possible for many more situation, because generally villagers cannot afford to pay for machines by themselves. Bricks are made of clay, sand, cement and water. The common practice for self-produced bricks do not consider the nature of these components, and no analysis on their suitability is usually conducted. It must be said that only certain types of sand and clay are suitable to be used to make bricks with certain properties, factor that is commonly underestimated. Analysis should be conducted beforehand about the nature of these components by technicians. Furthermore, treating bricks is another main phase that should be conducted to improve their structural and durability properties. To reduce the risk that people use bricks as building components which are not already performant because not treated, training session and direct demonstration should be conducted showing them the properties of treated and non-treated bricks compared to each other. This can be easily done by a drop off test on the ground without specific devices, to aware villagers about the importance of this step.



*Figure 97: Damaged not-treated brick at the village of Pipaltar*

C7: the on-site construction of brick walls includes the use of mortar and steel rebar's when interlocking system is used. During the conducted on-site inspections, it has been noticed that the construction is often conducted by local villagers without skills and expertise. In the construction phase, often weak and instable points are created due to the not straight application of bricks; this is made easier to do by bricks with interlocking system, permitting the application of brick layers perfectly one on each other. When a mortar layer is necessary between bricks, it is generally made too; the mix of the mortar is always made by feelings, without following a certain mix proportion of the components and then compromising the whole collaboration between bricks; for interlocking bricks, to cut the costs of the house, steel rebar's are putted as less as possible and still generally only when strictly imposed by the building code. The walls are often plastered at the end of the construction, to hid the construction imperfections that inevitably have been done without knowledge of the workers. This is enough to give to the villagers the feeling that houses have been well-built. As it is easily understandable, these processes, especially when combined with each other, provide housing solutions that have not satisfactory performance, not only when an earthquake happens but even in a working situation. It is not feasible thinking that all the villagers can afford to pay



expert workers when building a house is needed, due to their lack of money availability. However, the structural performance of the house and even its appearance can already be improved with simple measures. Firstly, training session given by NGOs can aware local people about how they should make the house, as it is already done for many villages. A certain mix composition of the mortar that could be generally suitable, with precise proportions of materials that must be used not to compromise the efficiency of the material, should be provided to the local workers not to let them work and making the mix only based on their experience. However, it has been noticed that of all the construction steps that should be followed when building a house, in many cases the lack of knowledge about on-site application of bricks is much better than phases that include making material directly on site, as it happens for the concrete. Training sessions about steps that must be followed by the workers in this phase and a precise mix for the mortar could be already enough not to compromise the structural performance and appearance of the house.

C8: the durability issues linked to the building elements made of masonry bricks are linked to two main aspects: firstly, the composition of the bricks themselves, and secondly, the environment and boundary conditions where the house has been built. About the first, no problems incur when bricks are bought directly from a certified producer, where it is reasonable to assume that the composition of the bricks I has been beforehand designed and checked during production phases. However, this would require higher amount of money than the situation when villagers locally produce their own bricks, using local materials. In this case analysis on the quality and the nature of the used materials should be conducted to verify if they are suitable or not for their purpose.

The point of view of a technician is in this case needed. About the environmental conditions, it is important that the walls are made straight and compact and that the mortar layer is made as thin as possible not to create infiltration points into the building element. Then, the field characteristics must be considered to build houses located far from obstacles and aggressive components, as not in direct contact with soil or close to inclined lands. Before starting the construction of buildings, once again the point of view of a technician is needed to analyse the best location for a certain intervention.



*Figure 98: Construction on site*



*Figure 99: Construction on site*

C9: during on-site inspections about the local construction phases that are followed by villagers, the most critical topic that has been noticed is the lack of knowledge about making concrete. Because of the nature of the material itself, that includes the fact that it must be mixed and made directly on the site just before its application, a high level of

attention and knowledge is required during this stage not to compromise the final quality of the material when hardened and then the structural performance of the concrete elements. As already well-known, concrete is made of cement, sand, aggregates and water. The cement is directly bought from producer; no attention is paid to the quality or the type of cement, the choice is usually made on a money base. However, it would be more suitable if houses were built using Portland cement instead of Pozzolanic cement, because the latter one requires more time to be hardened and generally a low level of treatment is applied: because Portland cement requires less time and water to be hard and the price difference is not usually highly remarkable, the first would be more suitable, at least generally speaking. When the money availability of the owners is high enough, sand is bought directly from a supplier; in this case, the suitability of this component for building purposes is certified and no problems generally incur. However, when costs must be cut, sand is even taken directly from local sites, depending on situation by situation, close to local rivers or caves. Here, no analysis about the composition of the sand are conducted. It must be said that because of the aggressive components that could be present into the soil, certain types of sand are definitely not suitable for a building purpose, for example salty sand or one close to industries, where the probability to find aggressive chemical components into that is higher. It is then advised, whenever it is possible, to buy the sand to make concrete directly from a certified producer. The used aggregates are usually obtained by cutting local stones. The size of them is generally made randomly and by feelings by local workers, without paying attention on the round shape that aggregates should have to give better cohesion and compaction. It must be said the aggregates and compaction are the two main factors that give the strength to the concrete; a not suitable shape or size of

them can highly compromise the structural performance of the concrete when hardened, as well as its durability that will be described deeper later. Even more that how it is valid for the sand, because of the importance of the aggregates into the determination of the concrete properties, whenever it is possible aggregates bags should be bought directly from a producer instead of making them locally, trying to cut the costs to the house, when this is a problematic factor, from other aspects.



*Figure 100: Mixing concrete on site*

C10: when the mix of the concrete is defined, the material is then made. The proportions of components are generally defined beforehand, at least for cement, sand and aggregates: it is common practice to use a ratio of 1:2:3 respectively. However, the amount of each material is based on volume measures instead of mass ones and again it is determined roughly, using low quality devices and with low level of precision. Furthermore, the amount of water is determined only by feelings of the workers and their past experiences. It must be said that these two aspects highly influence the properties of the material when hardened. Finally, the material is then mixed by hand because of the lack of specific mixing devices and the impossibility to buy them. Not to compromise the properties of the concrete or to make a final mix that is suitable for the structural purpose it has been designed for, technical assistance or at least a technical concrete recipe, determined beforehand by technicians, should be



provided to the workers. Already training session have been provided in many villages; however, without an on-site supervision when concrete is made, it has been noticed that local workers tend to follow their own experience instead of the indications given during the training session. Supervision from a technician during these phases would be a useful solution to check the making phases follow the indications beforehand determined, however it would require money that normally are not affordable for villagers. The concrete is then applied on the site by hand, without using moulds. The result is often that the shape of the concrete elements is not straight and with several weak points. When applied on the site, the concrete is then treated for a certain time that varies from 2 to 7 days depending of the needs of the owner and the expertise of the workers. Even if a 28-days-treatment is not applied, 7 days of curing are already a reasonable treating time looking at the current situation. However, during this time the construction keeps going on and brick layers are applied on the top of concrete elements even during the treatment. This compromise the compaction processes that incurs: the concrete should be left free from external loads at least for the treating time. The result of this processes is the not straight shape of concrete elements both vertically and horizontally, and the early creating of weak points.

Common practice is then plastering the concrete to hide the imperfections made during the construction stages; however, this cover can improve only the appearance of them, but the structural and durability performance of the elements stay compromised. It is highly important that workers are warned about the importance of these waiting and treating time. Looking at the current situation, because of the lack of knowledge of local people about construction processes, it means that more

effort is put about the appearance of the house and its elements instead of their actual performance as building elements, for example plastering or covering imperfections that have been made. Without a direct on-site supervision or a specific ability or knowledge of the workers, this procedure will keep going on.



*Figure 101: Concrete element with no planarity at the village of Ratankot*



*Figure 102: Concrete element with no planarity at the village of Ratankot*

C11: the quality of the concrete directly influences its reaction against aggressive environment and components, as well as the composition of the material itself. The size of the aggregates and the amount of water used into the mix, then its compaction factor, influence the protection behaviour that concrete has related to the steel rebar's. A not adequate composition of the material

causes spalling of the material itself, leaving the rebar's unprotected and highly subjected to aggressive components, risk causing corrosion initiation for the steel elements. Furthermore, if the quality of the concrete surface is poor, with high presence of deep and not distributed voids, aggressive components can get easily inside the mix transported by water, making the pH of the material dropping down and causing carbonation for both the concrete and the steel elements. For the concrete elements, carbonation mechanisms can be at least reduced if not denied using Portland cement instead of Pozzolanic cement. However, the necessity of a homogeneous surface with suitable quality and treatment stays valid to keep the steel rebar's protected. The planarity of the surface can be improved applying concrete in moulds on the site, that give the shape to the elements instead of applying the concrete by hand without guidelines. These aspects must be considered with high priority even considering the fact that maintenance operation is more expensive than choices at the design stage; in a context with lack of money availability, this risk can be reduced by a certain beforehand-determined quality of the material and adequate construction operations.

### 16.3 Conclusion

As a result of the risk assessment, the level is high regarding building earthquake resilient housing in Nepal. The highest external risks are no technical assistance, not enough manpower, unaffordable housing or not willing to pay for it and no acceptance of the design. The highest design risk is the low quality of materials and the highest construction risks are exposure to external conditions, low quality and production, lack of knowledge about construction, wrong or no treatment of the

materials and an insufficient mixture of the concrete. Overall, the external risks and construction risks are the highest.

In the risk strategy, a mitigation plan is set up to avoid, reduce or transfer these high risks. External risks can be mitigated to take the external factors into account when designing the house, such as social standards, traditions and cultural differences, but also technical assistance for the locals to be able to receive grants. Construction risks can mainly be mitigated with technical assistance, as there is a lack of knowledge on **how** to build. However, on paper these risks seem to be easily mitigated but in reality, it is extremely difficult. First, to have more technical assistance, more experts need to be trained and the process has to be supervised. This costs manpower, time and money. Second, the right building method needs to be applied in order for the locals to receive grants. With the complex government, this is difficult. Third, the house has to respect the social standards. To achieve those three factors and be compliant is a challenge.

# PART VIII. LONG-TERM PLAN



# 17 Long-term plan for upscaling of implementing earthquake resilient housing

Ratankot has been the right choice for a case study, but now it is time to look at the bigger picture again. After five teams, SSN is not just a multidisciplinary project anymore, but SSN is going to take the next step. What **is** the future plan of SSN exactly and which direction is the right one? What strategy does SSN have to take on to fully use the available resources and maximise the opportunities? And which stakeholders can help SSN to be successful in the future?

In the previous chapters the house has been validated and recommendations for optimisation have been made, an analysis of the context regarding upscaling has been done as well as a risk strategy. With all this information combined a long-term plan for upscaling of implementing earthquake resilient housing has been created. First, the strategy for SSN is described with an implementation method and how to minimise the weaknesses and optimise the strengths. Second, an engagement plan that explains how SSN can collaborate with stakeholders to successfully achieve the long-term plan. Third, the long-term is visualised in a pathway with the essential future steps.

## 17.1 Strategy for SSN

### 17.1.1 Strategy

The SWOT analysis in the previous chapters have shown the best practices of different organisations. In this chapter that research is used as a base for the strategy for SSN and practices and strengths, weaknesses and opportunities that are important to consider in the future.

The power of Shock Safe Nepal lies in the fact that it is a knowledge organisation and affiliated to the students of TU Delft who are doing independent research. Its knowledge is based on technology which is a crucial factor in the quality of current and future rebuilding of Nepal. It is important to realise why organisations that SSN works with are chosen.

Certain organisations have a large rebuilding capacity but regarding the technical aspect they are mainly focused on complying with the Nepali building code. This building code however still gets altered occasionally and is not necessarily perfect. The choice can also be made to work with knowledge institutions. However, in this case it is important to realise the meaning of the research and which (implementation) organisations/actors need the research done and how it can improve implementation of building in Nepal and go from theory to into practice.

SSN is **not an implementing partner** and does not have the capacity (or legal status) to be so in the near future. It can however do research that is valuable to implementing partners, the NRA and the DUDBC. It is important to realise who the research will be linked back to and who might find the research useful.



## Areas

Shock Safe Nepal is not seen as a partner organisation of the government, SSN is **not legally bound to certain areas** in Nepal where they have agreed to give technical assistance. Partner organisations/NGOs sign up to be contractually bound to areas in Nepal and have a responsibility towards HRRP of sharing their progress in this area. SSN is currently not an NGO and should therefore work with organisations who handle the legal aspects to implement the design in suitable areas where the organisations are located.

An opportunity that arises from this fact is that there are numerous areas in Nepal where there is no technical assistance or implementation partners active (through social media, SSN has received requests for help in rebuilding in areas where there is no assistance (yet). In these areas, the design could be very valuable, currently also because of the fact that CSEB bricks can be produced onsite in remote areas. The pilot house was built in Ratankot, which is located in the district Sindhupalchowk. There are 13 other districts in Nepal that need technical assistance and where rebuilding is needed.

It is however important to realise that SSN is a knowledge institute. Another option is to share the research with those organisations active in implementation countrywide. In this case SSN has to realise the importance in sharing of information with possibly interested organisations. These organisations can then decide if the design and the materials used are a good combination with a certain area that they are responsible for.

## Community

### *Owner/community driven approach*

Organisations often say *'we do not build; we use the owner driven approach and the people build themselves. We just build a demo house which is then copied.'* It is important however to **show people how** to build. If SSN were to work with implementation of houses it is important to use an owner driven approach and set up a system in which people build themselves. However technical assistance is important during the building. A community driven approach is also a possible approach to building the optimised design of the house.

When residents control the major decisions, and are free to give their own input to the design, construction or management of their housing and it stimulates individual and social well-being. However, when people have no control over, or responsibility for key decisions in the housing process, it may instead become a barrier to personal fulfilment and a heavy load on the economy. (J. Turner, 1976)

### Optimal impact

It is important to realise what the external effects (positive and negative) of building can be. The positive impact of a house can be increased by increased working with the local community and empowering them through the building of the house. Optimal impact has to be achieved.

### The design of the house

The design of the house should be socially optimised before being implemented. For this the PASSA approach can be used, interviews can also be done regarding the needs of the villagers (Bajracharya, 2011).

The following ways to implement the design assume that the building design is technically validated. In March 2017, the Building Catalog has been published. In the Building Catalog the use of Compressed Earth Interlocking Bricks was accepted. This means that if the design using interlocking bricks is to be chosen, the household will receive a grant for it. That is, if the Mandatory Rules of Thumb have been used in the design

### 17.1.2 Implementation Methods

#### Implementation method for Ratankot

To implement the validated design in Ratankot a blank design has to be handed in at the VDC. As the use of CSEB has recently been added in the Design Catalog (March 2017) this will now be possible without going through the DUDBC as the VDC can approve the design. However, the design will have to be checked with the local community to optimise it in terms of traditional organisation of a house. A business around the CSEB brick press can be set up in the

village and the treatment of bamboo in the village can also be further developed to reduce costs.

#### Implementation method for Sindhupalchok

The organisation that is active in Sindhupalchok that SSN has close contact with is Habitat for Humanity. There are also other organisations active in Sindhupalchok that SSN could possibly be working with (HRRP, 2017). Therefore, to implement further in Sindhupalchok it is important to collaborate. The design would have to be handed in at DUDBC and to be accepted on district level.

#### Implementation method for the whole of Nepal

An implementation method that would be effective is to implement the design throughout Nepal. This can be done by 'donating' the design to NGOs and INGOs and their implementing partners in the field.



### 17.1.3 SWOT/TOWS of SSN

A SWOT analysis of SSN is shown below in Figure 103. In combination with the analyses the TOWS matrix is set up by maximising the opportunities and minimising the threats through strengths and weaknesses. The TOWS matrix indicates which steps need to be taken, and which not, to be as efficient as possible in the long term. This can be seen as the conclusion of SSN's strategy.

#### SWOT

	<i>Helpful</i>	<i>Harmful</i>
<i>Internal</i>	<p><b>Strengths</b></p> <ul style="list-style-type: none"> <li>• Approachable, barrier is low as we are students</li> <li>• Multidisciplinary team</li> <li>• Different team roles</li> <li>• Quality control; advice and feedback from professors from one of the best universities of the world (TU Delft)</li> <li>• New/fresh/innovative view on certain problems</li> <li>• Deliverable of high quality research</li> <li>• Interest in project from previous Shock Safers is High</li> <li>• Analytical thinking</li> <li>• Project initiated by students of TU Delft</li> </ul>	<p><b>Weaknesses</b></p> <ul style="list-style-type: none"> <li>• SSN is part of the TU Delft curriculum, which has boundaries for the project</li> <li>• Inconsistent money flow</li> <li>• Is a student project, not run by professionals?</li> <li>• Lack of greater structure and foundation</li> <li>• Lacks fulltime member in Nepal/The Netherlands</li> <li>• Lacks connection between research/educational institutes such as TU Delft and Tribhuvan University</li> <li>• A team is only available for 2/3 months</li> <li>• Determination of the problem is time consuming</li> <li>• Knowledge exchange between teams not efficient</li> <li>• Students underestimate the complexity of the problem before starting the project</li> </ul>
<i>External</i>	<p><b>Opportunities</b></p> <ul style="list-style-type: none"> <li>• Collaborating with (I)NGOs</li> <li>• Enthusiastic students from the TU Delft</li> <li>• Course of TU Delft, Possibilities in expansion in the structure of education of the TU Delft</li> <li>• Research into different aspects of Earthquake resilient building</li> <li>• Previous team members that are doing their thesis about aspects of SSN now</li> <li>• Funding possibilities through network</li> <li>• Supporting technical assistance in building in Nepal through research</li> <li>• Collaborating with other research institutes</li> </ul>	<p><b>Threats</b></p> <ul style="list-style-type: none"> <li>• Lack of sufficient knowledge transfer between teams which results in loss of essential information</li> <li>• Lack of continuity</li> <li>• Distracted/ getting too involved by the goal of the NGOs</li> <li>• More involvement than 8 weeks is necessary for the team</li> <li>• The wrong approach being chosen because of lack of investigation</li> </ul>

Figure 103: SWOT Analyse

#### TOWS

Based on the SWOT analysis as described before, a TOWS matrix has been developed to match the threats and opportunities with the project's weaknesses and especially its strengths (Wehrich, 1982). The TOWS matrix describes the interaction between the four sets of variables as described in the

SWOT analysis - strengths, weaknesses, opportunities and threats - and provides the strategies that need to be followed to on the one hand maximize the strengths and opportunities and on the other hand minimise the weaknesses and threats that are related to SSN.

	<p><b>Internal Strengths (S):</b></p> <ol style="list-style-type: none"> <li>1. Approachable, barrier is low as we are students</li> <li>2. Multidisciplinary team</li> <li>3. Different team roles</li> <li>4. Quality control; advice and feedback from professors from one of the best universities of the world (TU Delft)</li> <li>5. New/fresh/innovative view on certain problems</li> <li>6. Deliverable of high quality research</li> <li>7. Interest in project from previous Shock Safers is High</li> <li>8. Analytical thinking</li> </ol>	<p><b>Internal Weaknesses (W):</b></p> <ol style="list-style-type: none"> <li>9. SSN is part of the TU Delft curriculum, which has boundaries for the project</li> <li>10. Inconsistent money flow</li> <li>11. Still a student project</li> <li>12. Lack of greater structure and foundation</li> <li>13. Lacks fulltime member in Nepal/The Netherlands</li> <li>14. Lacks connection between research/educational institutes such as TU Delft and Tribhuvan University</li> <li>15. A team is only 2 months available</li> <li>16. Determination of the problem is time consuming</li> <li>17. Knowledge exchange between teams not efficient</li> <li>18. Students underestimate the complexity of the problem before starting the project</li> </ol>
<p><b>External Opportunities (O):</b></p> <ol style="list-style-type: none"> <li>1. Collaborating with (I)NGOs</li> <li>2. Enthusiastic students from the TU Delft</li> <li>3. Course of TU Delft, Possibilities in expansion in the structure of education of the TU Delft</li> <li>4. Research into different aspects of Earthquake resilient building</li> <li>5. Previous team members that are doing their thesis about aspects of SSN now</li> <li>6. Funding possibilities through network</li> <li>7. Supporting technical assistance in building in Nepal through research</li> <li>8. Collaborating with other research institutes</li> </ol>	<p><b>SO: maximize - maximize (O,S)</b></p> <ul style="list-style-type: none"> <li>• 7,6 Create structurally solid design through research and that follows the building code</li> <li>• 1,6 Set up network between research institutes such as Tribhuvan and an NGO such as ASF and improve building code with information from research done</li> <li>• 8,6 Setting up a cooperation between the TU Delft, Grenoble University, University of Tribhuvan around a shake table in Kathmandu.</li> <li>• 1,6 Implementation of the research design of SSN by NGO</li> <li>• 5,7 Use knowledge of thesis of previous team members to design the house &amp; effectively disseminate research to where it is needed</li> <li>• 6,3 Creative methods of acquisition of funds before departure of teams</li> <li>• 1,4 Work closely with actors working on technical assistance (ASF, HRRP)</li> <li>• 3,9 Research in more detailed aspects through other courses from TU Delft</li> <li>• 4,2 Send more than 1 research group at a time to research different aspects of the design</li> <li>• 8,1 Easy to collaborate with research institutes as we are students.</li> <li>• 5,6 Possibilities of research into radically new/innovative retrofitting methods</li> <li>• 2,7 Maintain SSN as an ongoing project and create a knowledge platform</li> <li>• 2,1 Make it easy for TU students to get involved in the project/ research</li> </ul>	<p><b>WO: minimize - maximize (O,W)</b></p> <ul style="list-style-type: none"> <li>• 11/13 Create a foundation for the structure and the continuity of SSN regarding supervision in order to establish realistic goals, constant information and money flow</li> <li>• 18, Optimise knowledge transfer to future SSN teams</li> <li>• 6,11 Acquire constant funds by collaborating with companies and NGOs</li> <li>• 8,15 Setting up a cooperation between the TU Delft, Grenoble University, University of Tribhuvan around a shake table in Kathmandu.</li> <li>• 2,18 Involve Nepalese students at the TU Delft closely with the project. Use unused potential in the project and as advisors</li> <li>• The multidisciplinary future teams should consist of at least 2 structural MSc students for the structural aspects and CME/TBM students for the project management for the project as a whole</li> <li>• Feedback of professors for the research is easily accessible and this will help achieving a certain level of quality</li> </ul>
<p><b>External Threats (T):</b></p> <ol style="list-style-type: none"> <li>9. Lack of sufficient knowledge transfer between teams which results in loss of essential information</li> <li>10. Lack of continuity</li> <li>11. Distracted/ getting too involved by the goal of the NGOs</li> <li>12. More involvement than 8 weeks is necessary for the team</li> <li>13. The wrong approach is chosen because of lack of investigation</li> </ol>	<p><b>ST: maximize - minimize</b></p> <ul style="list-style-type: none"> <li>• 6,7 Use members of previous teams to ensure transfer of knowledge</li> <li>• 7. Set up a foundation which consists of enthusiastic previous team members as point of contact and for continuity</li> <li>• 6. Set up protocol for knowledge transfer to the future team</li> <li>• 6,2 Approach students who follow courses regarding earthquake resistant building</li> <li>• 10,4 Bring professors and students together about SSN on a more regular basis, professors as advisors that are involved not only regarding grading</li> <li>• 8. Dissemination of relevant research questions to students of the TU Delft from NGOs</li> </ul>	<p><b>WT: minimize - minimize</b></p> <ul style="list-style-type: none"> <li>• 6/8/7/9 Use and elaborate further on the long-term plan of SSN team 5 as the base for following relevant and meaningful research.</li> <li>• 8, Approach someone working full time in Earthquake resistant building in Nepal as advisors of the SSN foundation</li> <li>• 6,19 Create a documentary to explain the project and problem in a direct visual way, improve communication of the project.</li> <li>• 7/8,13 Scoping and defining of the goal of SSN, mission and vision and implementation pathway</li> <li>• 9,12 Make readymade relevant and important research questions for capita selecta/thesis</li> </ul>

Figure 104: TOWS Analyse

## 17.2 Engagement Plan

To set up a strategy on how to cooperate and collaborate with stakeholders, the engagement plan for Shock Safe Nepal is developed mainly through the stakeholder analysis. In the extensive stakeholder analysis in Appendix II.A the problem perception and goal

of all the stakeholders are determined, as well whom they can collaborate with and whom they might be in conflict with. The scope of this engagement plan is solely stakeholders that affect SSN. The approach of this engagement plan is the process, which consists of consultation, participation, partnerships and communication. The objectives belonging to these aspects are defined as to be seen in Figure 105 below.

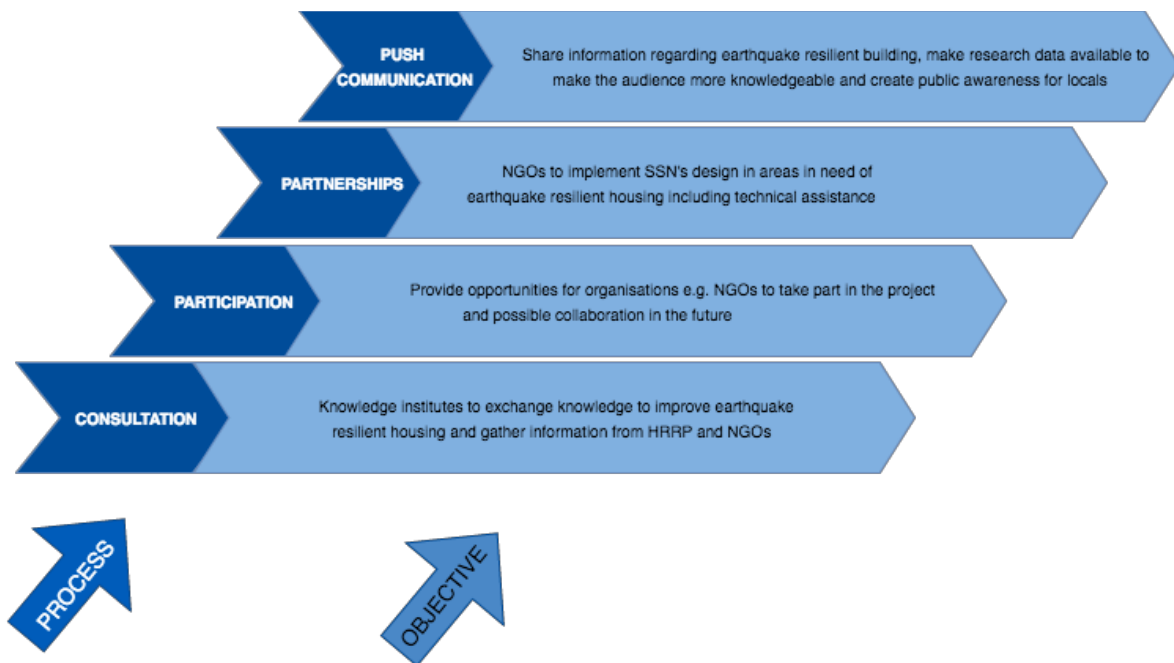

Figure 105: Engagement plan for SSN (adapted from Stakeholder Engagement 2017)

### 17.2.1 Process and objectives

#### *Consultation*

In order to create an optimised earthquake resilient house consultation of other knowledge institutes is essential. As SSN has been doing research knowledge exchange can take place. Furthermore, gathering information from the umbrella organisation HRRP is important in order to know the status of rebuilding in Nepal as well as what other organisations are focusing on and make the research done meaningful. NGOs can provide SSN knowledge about the implementation methods and technical assistance.

#### *Participation*

Contact organisations to create opportunities to participate in SSN in either knowledge exchange, funding or implementing.

#### *Partnerships*

As concluded from the analysis of the implementation methods, it is not feasible to implement the design by ourselves. Furthermore, with the risk strategies in mind, lasting technical assistance is essential in the process, which SSN cannot do as it is research based. Therefore, NGOs are needed for the implementation.

#### *Communication*

Research has been done and needs to be shared to reach those who need it as soon as possible. From the analysis of the external factors we can conclude that sharing knowledge is one of the main aspects. This can be done through trainings and technical assistance with the help of research institutes through organisations such as NSET and HRRP. Through communication SSN can share information

and make research data available regarding earthquake resilient building with and through organisations such as NGOs, HRRP, governmental organisations. Also, communication with the inhabitants of Nepal is necessary, as public awareness is essential.

### 17.3 Implementation pathway

The steps that have been identified in the engagement plan in previously are organised in the following implementation pathway. The steps are colour coded into regulatory, implementation/pilot/ technical and organisational. The regulatory goals are difficult to influence as SSN is still a small organisation. Recognising these goals can show the importance to other stakeholders active in Nepal who are involved in regulations. Implementation regards the building of the design in the future. Technical goals are goals that are currently defined of holes in the technical knowledge that are important for the end goal of a completely validated and as much as possible earthquake resistant design. In reaching these goals the organisational goals are also essential to help shape the future research.

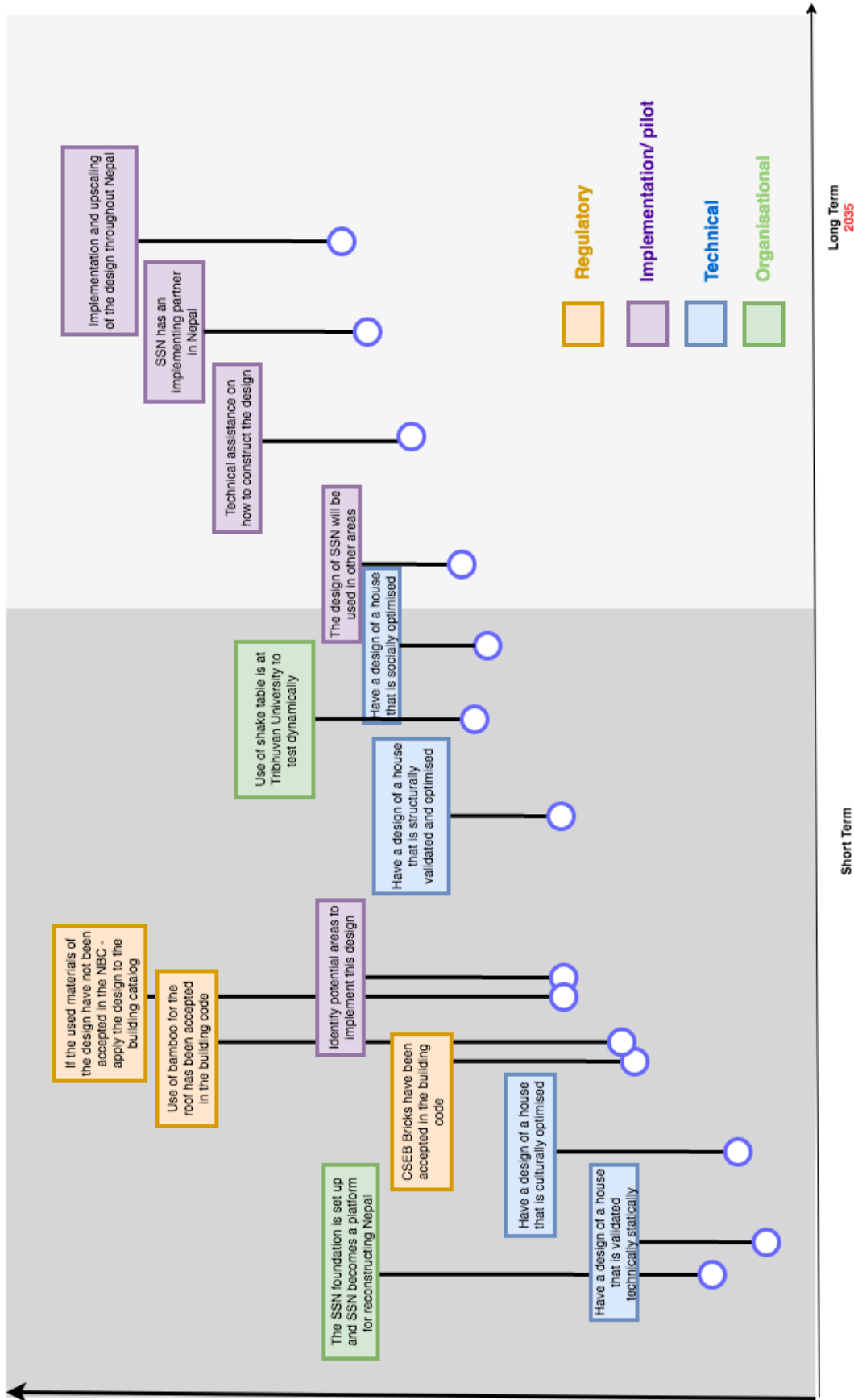

Figure 106: Implementation pathway of SSN



### 17.3.1 Steps in the implementation pathway

As stated in Figure 106 above, certain steps have to be taken in a specific order. Those steps are further explained in this paragraph.

#### Technical /design of the house

1. Have a design of a house that is validated technically statically
2. Have a design of a house that is culturally optimised-- amount of rooms, traditional roof, cows and sheep area, storage option
3. Have a design of a house that is validated technically Dynamically/ on a shake table
4. Final costs of the base house.
5. Design for self-sufficiency of water use
6. Design for self-sufficiency in terms of energy Research into other building methods/ retrofiting

#### Regulatory/Legal

1. CSEB Bricks have been accepted in the building code
2. Use of bamboo for the roof has been accepted in the building code
3. IF CSEB has not been accepted in the NBC - apply the design to the Building Catalog

4. If CSEB is accepted into the Building Catalog, check of this is with or without a frame -> choice between continuing with design of pilot house or altering design to make walls fully loadbearing.

#### Organisation

1. Team 6 - at least two structural (Structural Engineering, Building Technology), building technology at least one architecture BSc background.
2. Identifying key areas where this design would be feasible
3. A shake table is available at Tribhuvan university
4. A board of SSN is set up and SSN becomes a platform for reconstructing Nepal
5. Research done at the TU Delft in Courses

#### Implementation

1. SSN has an implementing partner in Nepal
2. SSN builds pilot house 2 in Ratankot
3. People in Ratankot are taught how to build the design
4. The basic design can be given to NGOs looking for designs for areas suitable for the design

## 17.4 Conclusion long-term plan & implementation pathway

An implementation pathway and long-term plan have been developed. However, it is a pathway that should be seen as a guideline but can be altered. The context in Nepal changes all the time and this will have an influence on the long-term plan.

To be able to implement the planned elements the project has to gain momentum at the TU Delft, for this it is important to continue working closely with professors and hopefully setting up the foundation will help in this. There are certain aspects in the implementation pathway that are more feasible than others and this can be considered in the future.

A photograph of a traditional, rustic structure, possibly a kitchen or storage area, with a thatched roof made of dried leaves or straw. The structure is built with mud and wood. The background shows a dirt path and a lush, green hillside. The text "PART IX. DISCUSSION, CONCLUSION, RECOMMENDATIONS" is overlaid in white, bold, sans-serif font across the upper portion of the image.

**PART IX.**  
**DISCUSSION, CONCLUSION,**  
**RECOMMENDATIONS**





# 18 Discussion

This chapter will elaborate on the limitations of the results of this report. These should be considered by future Shock Safe Nepal Teams, interested parties involved in construction in Nepal and general readers. The discussion aspects are organised according to the main subjects analysed in the report.

## General information

This report is the result of the Multi-disciplinary Project at the TU Delft, carried out by students. The results of the pilot house can be used by other parties in Nepal, however the design should **never** be built without thorough technical assistance in Nepal. There is only so much research that one team can conduct in the given time and therefore it is essential for readers in Nepal to see this report as guidelines but not the design as ready-to-implement.

## Scope

Before departure, a project plan was drawn up with the aim of a long-term plan for upscaling and implementation. After working on the project for two weeks and a detailed inventory, the project plan did not seem to be feasible and the scope seemed too broad. Due to the complexity of the project, the country and its circumstances, the scope had to be adjusted. However, in order to be able to draw up a long-term plan and to be able to upscale the project, the pilot house in Ratankot had to be validated first and an analysis of the context had to be made thoroughly. Therefore, the scope was still not realistic which results in a comprehensive report - the final goal of SSN5 was to create a foundation for the inhabitants of Nepal, for future teams and the SSN Foundation.

## 18.1 Technical discussions

A large part of the project was dedicated to the technical aspects of the pilot building. It considers the validation of the materials, the structure and quasi static situations. It should therefore be discussed how and why these analyses, calculations, decisions and practical works, have been executed.

The design mainly follows from the Nepalese Building Code and the Design Catalogue. The socio-cultural aspects of building have not been sufficiently considered. It would be necessary to further research people's needs regarding housing of rural areas. The implementation and materials were specifically validated in Ratankot and are therefore not necessarily valid in other areas.

Even though the implementation was validated, the construction site is not ideal for the construction of the house. It has been built on sloped ground. One of the general rules of earthquake safe building is making sure that the slope is stable. This has not been done by previous teams and should have been considered a higher priority before and after construction. During the stay in Nepal, it was found that slope stability is a problem in many places and can form a danger for both people and housing.

which are the bottlenecks of the structure, further, after which calculations are in order.

### **Material analysis**

The bamboo analysis in this report, regarding bamboo, steel and CSEB, are mainly based on sources and laboratory tests done by other researches with limited documentation of the test setup. It shows limited information and results in less credible assumptions and decisions regarding the materials used in Ratankot. Therefore, laboratory tests using the materials from Ratankot should have been conducted for comparisons and more credible results.

Concrete quality has been analysed through laboratory tests and on-site inspections. It was noticed to be poor about both structural performance and durability. However, the compression strength of the material seems to give structural strength high enough to bear static loads in a working situation. These results have been achieved through using a Schmidt hammer, which makes the results reliability lower than if a certain mix design receipt would have been given. However, values given by the Schmidt hammer have been compared to compression strength tests results, gaining reliability.

### **Static calculations**

When installing the roof onto the walls, it was noticed that the connection between the walls and the roof did not align and fit. Primarily upon arrival, help was offered to the previous team to help finish the roof. It should have then been stated that this is not the way to build and connect the roof. Furthermore, when calculating the roof, it was assumed that these connections were rigid, but in fact the roof just lies on the walls. It should have been a higher priority to investigate and optimize these connections,

Static calculations for the load bearing walls of the house have been conducted consulting Indian Building Code and Nepalese Building Code parallel. When they lacked some contents, parameters have been determined using Eurocode. Steel rebar's have not been considered into calculations of the structural performance of the walls due to the uncertainties about their location into the walls. Based on the conducted material properties analysis, verifications of the walls structural performance have been made following indications of Eurocode mainly, which has been considered the most reliable source. Using the same source for both parameters determination and verification might have made the verification process more linear and reliable.

When determining the soil parameters, to validate the structural properties of the foundation, solely visual and minor practical tests and observations have been done. Because of these visual and minor practical tests and observations, many parameters remain assumptions. To form a greater and more profound understanding of its properties, more thorough analysis should have been done, by both previous teams and the current team.

Since assumptions were made, the credibility of these parameters is debateable, as will be the results of these calculations. Furthermore, the calculations on sliding and settlement may be considered, as sliding due to wind forces could have been assumed redundant beforehand as this is very unlikely to happen. The primary settlement has already taken place, since the house is already built, so these

calculations are mainly useful before construction.

### **Quasi-static calculations**

The acceleration of the ground that is needed to initiate the collapse of the walls has been calculate and then compared to the actual PGA that might be registered in an earthquake situation. In this case, the presence of embedded rebar's has been considered assuming the walls collapse mechanisms as three-pointed ones. This assumption might be affected by relevant uncertainties. Earthquake-related applied loads and structural response have been determined consulting Eurocode indications mainly due to the frequent lack of information of IS and NBC. More context-and-location-related source and indications might have been more suitable to be used. Further calculations related to the static non-linear and dynamic behaviour of the structures have not been conducted due to the topic complexity and lack of time.

The quasi-static calculations on the seismic bearing capacity are only based on a single source. The integration of multiple sources gives more inside in possible mistakes and a more credible result as a comparison is possible. The Eurocode 8 should have been consulted when performing these calculations, but due to a shortage of time, this was not done.

After finalising the excel sheet regarding the CSEB drop tests, for Build Up Nepal, the credibility was not further tested. The drop tests should have been carried out following the computed excel sheet. As for the shear test, initiative was taken to build a two pilot walls together with Build Up Nepal and the university of Tribhuvan. However, due to time shortage and lack of communication

with Build Up Nepal, the test was not finished.

The bamboo treatment test carried out in the village of Ratankot were successful. However, shortage of time and meetings, resulted in little education on independent operations by the villagers. The mechanics and proceedings of the device should have been elaborated on and better taught. Many conclusions have been drawn from the joint connections. It was understood, after analysing, that they lacked on multiple mechanical and safety grounds. These concerns should have been shared in more detail and with more urge.

The most important discussion is the knowledge transfer. This continuous to be both an issue and an opportunity. Regarding the knowledge acquired during this project, much was discussed with the villagers and other involved parties. However, many concerns were left unspoken and some knowledge was left uneducated. More thought should have been paid to this subject.



## 18.2 Discussions about the context, upscaling and future of SSN

The socio-cultural aspects of building have not been considered as much as would be needed to build. Although it is possible to find possible future owners of a house based on the SSN design, that matches to the house, it would be necessary to further research people's needs regarding housing of rural areas.

The pilot house that is analysed and that parts of this report build on is a very specific design. The choice for the use of CSEB bricks by team 4 in the pilot house was in part made as the cooperation with Build Up Nepal was possible. Although the use of these bricks and the resulting design are researched, this is not the most favourable design method in all areas of Nepal. Although the implementation is validated (under certain circumstances) in Ratankot this is not therefore valid in other areas.

### Stakeholder analysis

The stakeholder Analysis is done as thoroughly as possible, however, as the analysis is based on interviews it can be subjective. Information gathered was checked in other interviews to get the most accurate results, and was optimising the information was an ongoing process. The inventory of stakeholders, power-interest grid, attitudes and the stakeholder network represent the current situation. It is important to recognise that changes in this can happen quite suddenly over time.

### External factors

The report gives an extensive oversight of the results of research on the external factors that influence building in Nepal, this

is based on the current situation. The large part of this research will remain valid, however, legislation and the political organisation can change. In that case, the results in this report can be used as a base for future teams to add alterations to should they find changed external factors.

### Implementation methods

Implementation methods are used in the research of widely varying organisations. These are chosen based on links with SSN and differences in methods. However, there are many other organisations working in Nepal, whose implementation methods will vary from the results given here. For the purpose of refining the implementation strategy and long term goals of SSN these case studies are significant. The final outcomes are based on interviews and therefore are affected by this form of research. They are based on the answers given by employees of companies and the interpretation of the SSN team. Threats in the SWOT analysis were therefore also more difficult to get into the results accurately as organisations are less willing to discuss these.

### Risk assessment

The risk assessment determines the risks regarding the external-, design-, construction risks. Mitigating those risks do not look difficult in theory, but due to many factors the feasibility is affected. Those factors, such as external factors and stakeholders involved. Therefore, the external factors have been considered when the strategy was created.

As Nepal is a complex country, the source of the problems has to be solved before the risks can actually be mitigated.

## **Long-term plan for upscaling of implementing earthquake resilient housing**

The long-term plan in the final chapters of this report is based on the research done and following steps that were determined throughout the project. It is formed by the SSN team but following teams have the freedom to add, remove or reorganise goals if the significance or priority if this is seen as important.

# 19 Conclusion

The goals of this report were to validate and optimise the design of the pilot house technically, analyse the current context of Nepal and its implications for the SSN in future projects and develop a preliminary strategy for further implementation of the design in Nepal.

The research question will be answered by the sub-questions in the next paragraphs.

*To what extent is the structural design of the house earthquake resistant and what is required to create a long-term plan to upscale in rural areas in Nepal?*

## 19.1 Technical conclusions

Preliminary to the research conducted in Nepal it was desired to determine the structural and technical properties of the pilot house and the feasibility of the required materials. The information on the structural and material properties, are intertwined with the question as to what extent is the design earthquake resilient and how it can be optimised. In the following part these subjects will be discussed and revised.

*What are the structural and technical properties of the pilot house, and what is the accessibility and feasibility of the required materials?*

From the research on bamboo, particularly Bambusa Balcooa, it has been found that the mechanical properties of this material are difficult to predict and rigidly determine. Solely relying on literature research, gives a wide range in values for several properties. However, after roof calculations, taking the lower values from these ranges, it showed that the material was strong enough. It can therefore be concluded that bamboo is indeed a strong material to build with, but

thorough research and safety measures must be taken. Regarding the structural performance of the roof, the joints were immensely misconstrued, the structure over dimensioned and therefore too heavy, but mechanically safe on bearing the induced loads.

The load bearing capacity of the house, given by CSEB brick walls, has been estimated for an ordinary working situation. Assumptions have been taken estimating the loads combination, per Indian Standards, as well as the structural properties of the CSEB, based on tests conducted by Build Up Nepal. However, some wall compartments did not match guidelines' limit values (e.g. eccentricities) due to an inhomogeneous distribution of the loads to the structure. Infilled rebar's have not been considered while conducting structural calculations but bricks only, then the structural performance of the house should be safer than already estimated.

From site inspection and an earthquake safe building point of view, the site has been determined as an unfit construction location, due to sloped ground, little construction area and no retaining structures. The soil properties have been mainly determined, making assumptions and following limited research data. They are therefore still unreliable but a good start. After bearing capacity, sliding resistance and settlement calculations, using these properties, it was found that the soil and the foundation are structurally performing as required. However, it was found that the foundation is largely over dimensioned.

In general, the used materials and the structure of the pilot house have been thoroughly researched and tested. The mechanical properties of the materials and the structural performance of the house is acceptable and of required capacity. It must, however, be said that the quality is still relatively low which can and should be

improved. Even though it has been found that the structure is wall-bearing, it can be said that the overall static, structural performance of the pilot house works properly, taking all assumptions into consideration.

*To what extent is the design earthquake resilient and in which ways can it be optimised?*

The load bearing capacity of the CSEB walls has been investigated in an earthquake situation. Shear and bending stresses caused by earthquake-related forces have been estimated following the Eurocode guidelines. Mostly stresses have been determined higher than the (expected) induced stresses for safety reasons. The ground acceleration necessary to cause compartments collapse has been determined and then compared to the PGA. Two different scenarios have been investigated. If concrete bends guaranteed the box-behaviour of the structure, 3-points collapse would happen. Due to poor properties of the concrete, a punctual overturning collapse might happen, which can be caused by lower PGA values. In this case, most of the compartments could not bear the ground vibrations. Rebar's have not been considered in the structural calculations, their contribution should make the house performance safer for both bending and shear stresses. The investigated situation represents a small part of the whole panorama of verification that might be done to analyse the structural safety of the house. This scenario gives only insights about the potential performance, because dynamic loads are applied statically. For these reasons, to analyse more deeply the performance of the house, non-linear or dynamic calculations could be conducted as well as FEM modelling.

Regarding an earthquake situation, the foundation was solely researched and calculated following quasi-static conditions.

The earthquake conditions were derived from the Peak Ground Acceleration, which does not necessarily give an indication to the magnitude on the scale of Richter. The calculations only consider the bearing capacity of the soil. It was found that in case a PGA of 0.6g occurs, the bearing capacity will hold. Increasing the PGA further than 0.7, would mean in some cases failure regarding the assumed internal angle of friction. However, it must be said that no further thorough investigation was done regarding this matter. It is also not investigated to what extent the foundation would be effected because of the inertial effect on and of the superstructure would be. The assumed situation is therefore not complete and yet partly unreliable.

Regarding the optimisation of the house, a lot can be accomplished. The most important part is that the people in Nepal must be aware of the importance of good material. Casting concrete with the perfect mixture, curing bamboo the right way and connect material together with sustainable solutions are for now far from desired. The quality of the CSEB can be investigated with the suggested drop test so that the load bearing wall capacity is high enough to bear the loads. The blocks also must be protected against extreme weather conditions to maintain the strength of the individual blocks at the bottom part of the structure. For now, the villagers often don't know the right approach of using materials. After site visits it has been noticed that the lack of knowledge can result in dangerous situations. Therefore, professional technical assistance is one of the priorities in the coming years. This will save a lot of money for the villagers and will provide a faster and safer rebuilding of the country.

## 19.2 Upscaling and future of SSN

*What are the most important factors regarding the context and the requirements to upscale and implement further in rural Nepal?*

Nepal is situated between India and China and economically very dependent on them for import and export. It is vulnerable regarding climate change and its mountainous geography makes transport and infrastructure underdeveloped. Nepal has an unstable political system and earthquake reconstruction falls under the ministry of urban development, federal affairs & local development as well as the more recently initiated National reconstruction authority. Complicated social structures and an embedded caste system add to the external factors that have to be understood when building in Nepal. The large number of NGOs working in different ways and the government trying to keep track of and in some cases, organise the stakeholders makes for a complex system of reconstruction. This can be seen especially in terms of logistics, which takes time and leaves many locals still without housing nearly 2 years after the earthquake. Government institutions can be difficult to work with; processes are slow and corruption has to be considered. Getting designs accepted by government institutions is time-consuming and not feasible for SSN without working together with other stakeholders. The NBC (National Building Code) is imperfect and largely based on the Indian building code.

*What are the possibilities for SSN in rebuilding Nepal?*

To be most valuable it is necessary for SSN to recognise itself as a knowledge organisation, in between the large number of organisations currently active in rebuilding. SSN will be of most value if it stays in this role and improves technical quality in designs rather than implement the design themselves, and should keep focusing on quality over quantity of houses. The stakeholder analysis shows the large complexity of the stakeholder network and ties between governmental organisations, platform organisations, inter- and non-governmental organisations, knowledge organisations and locals. The differences between stakeholders in terms of power, size, previous interactions of SSN and implementation methods combine in the importance of SSN having to keep working with organisations as Build Up Nepal, Habitat for Humanity, architects sans frontiers and HRRP as there is no use in doing research that is not based on and for organisations on the ground.

*What is the most feasible role of SSN in rebuilding Nepal for the long-term?*

The most feasible role of SSN in rebuilding Nepal is based on all the results of the prior research and combined in an upscaling plan, engagement plan and implementation pathway. Regulatory, implementation, technical and organisational goals need to be accomplished in the long term to work on developing and disseminating knowledge regarding the quality of earthquake resistant housing.

# 20 Recommendations

It is important that the house that has been built in Ratankot is seen as a pilothouse. The design must be completely validated, structurally and socially. We also recommend professors to be critical in this project as it regards a design of a house that is meant to be built and not solely a theoretical design. The further process with the design has to be tracked as a house that is built by students of the TU Delft, however the students are not responsible for the final use of the house and are not setting a certain safety level.

To improve some characteristics of the design, the earthquake safe building knowledge and this project, together with a more in-depth and reliable validation, general technical recommendations are in place.

Structural and durability-related characteristics of the pilot house have been determined through on-site analysis, laboratory tests and calculations. The conclusions regarding the static and quasi static performance of the house, are based on the current available, found and used sources. These might not be the most reliable or complete sources and could be investigated further, especially on quasi-static grounds.

It was found that the quality of building materials is generally lower than expected and necessary. This is caused by the overall lack of knowledge and concern on-site, especially while casting the concrete, pressing CSEB and connecting bamboo

sticks. In general, many operational mistakes are made. For future operations and construction, improvement of guidelines and technical assistance are required. Moreover, knowledge transfer and technical education is something that could be more elaborated on.

The load-bearing function of the house is built using CSEB bricks. Even if that is a well-known technology for the context, only a few tests about these bricks properties have been conducted, especially about their shear stresses, strongly related to earthquake situations. It could be beneficial and more earthquake safe if other materials are investigated. Furthermore, the structure relies on a wall load-bearing structure. This solution is generally weaker than frame load-bearing structures; the latter could be considered for further and safer future housing solutions.

It was noticed that little to no specific site analyses were conducted to find the most suitable location for construction. Also regarding technical validation or calculations not enough research have been executed. Earthquake safe building is largely effected by such research, especially due to the soil composition and the site layout. Therefore, a new, but similar design can be taken under consideration. More technical knowledge, physical data and calculations have been acquired by Shock Safe Nepal Team 5. This could be used, designing a better and optimized pilot building.

It is important to keep in mind that it is a research project, research has to be done into the design, the building and implementation of the design should therefore be done in cooperation with an organisation on the ground that can maintain



continuity and check that the implementation is done correctly.

Moreover, the researching subject should also be specific for the goals, interests and knowledge of this specific partner.

The research that has been conducted in Nepal, by SSN team 5, was relatively broad. To gain more in-depth results and research a more specific scope should be applied. Meaning a choice on a specific subject, examples of this are an in-depth research on CSEB, quasi-static research on the foundation or walls and/or tests on the soil. It has become more important for Shock Safe Nepal to gain more specific and detailed information on different topics. To achieve this in a structured way, scoping should be paid more attention to than it generally should for a project, due to the severe and life threatening nature of earthquake safe building.

The NBC should be seen as a guideline, as students from the TU Delft, technical research is the main goal and it is therefore essential that the design has been validated. However, the guidelines of the NBC need to be followed as this makes the acquiring of government grants possible for future house owners.

Shock Safe Nepal team 5 has started a cooperation with the University of Tribhuvan. The professors are willing to help and this is something to continue working with. Furthermore, it is important to incorporate the university in such technical operations to preserve and develop knowledge. Moreover, the university can be a great help and opportunity to start the construction of a shake table, which could be a great asset for Shock Safe Nepal.

The University of Technology in Delft contains a vast and diverse set of disciplines. The research topics are different

for every team. The teams should have affinity with the specific topic and should know beforehand what and how their contribution will be to this specific topic. It is recommended that the next team should consist of a minimum of two structural engineering students, preferably in their masters and a CME/TBM student regarding project management.

Create and share individual research topics that can be carried out as master theses. This can be done for NGO's in Nepal and SSN will function as a catalyst between students from the TU Delft and Nepal. This is however secondary to the research that is in the main focus of SSN.

When dynamic and quasi static calculations are considered as a research topic. It is recommended to use and compare multiple programs, specific to the topic. For example, TreMuri is a recommended to computer program to investigate and Finite Element method has not been considered further as well. This could be great for Shock Safe Nepal to pick up off.

It is recommended to further explore the space use of the house design and its social implications, as the house needs to fit in with the needs of people, yet not be structurally effected by these possible changes.

For other research, it would be of value to look into the houses that were traditionally built and ways of improving them. Our design is "new" and needs time put into education. The fact that the bricks can be made onsite however means it is very applicable in certain areas.

Explore the financing methods of building houses, look at how money moves through the supply chain and how materials can be

used that will benefit the whole community, get the \$3000 grant into the small-scale village economic cycle instead of straight to the larger cities. This way the \$3000 grant can function as a kick-start for the success of a whole village instead of solely the person who is able to now build his house and the companies that the owner buys his materials from.

## 21 References

- 1, S. T. (2015). *Shock Safe Nepal Team One*. Delft, The Netherlands: TU Delft.
- Adhikary, N. (n.d.). *Experiment with a locally constructed boucherie treatment plant in Nepal*. Retrieved from Abari : <http://abari.earth/treatment/>
- Agency, C. I. (2016). *The World Factbook*. Retrieved from <https://www.cia.gov/library/publications/the-world-factbook/geos/np.html>
- Agency, I. -U. (2016). *Foundation of Hope: Year One of Relief, Recovery and Reconstruction in Nepal*. Retrieved from <https://www.youtube.com/watch?v=IUGtQKzS2gg&feature=youtu.be>
- Andrew, B. (2016). *One Year Later: The Politics and Stories of Post-Earthquake Nepal*.
- Arce, O. (1993). *Fundamentals of the design of bamboo structures*. Eindhoven: Technical University of Eindhoven.
- Architecture Sans Frontières International*. (2017). Retrieved from <http://www.asfint.org/>
- Arya, A. S. (2013). *Guidelines for Earthquake Resistant Non-Engineered Construction*. UNESCO.
- Atlas, M. (n.d.). Retrieved 04 2017, from <http://atlas.media.mit.edu/en/profile/country/npl/>
- auroville. (2012). Retrieved from Website van auroville earth institute: [http://www.earth-auroville.com/earth\\_in\\_auroville\\_introduction\\_en.php](http://www.earth-auroville.com/earth_in_auroville_introduction_en.php)
- Auroville. (2012). *Auroville Earth Institute*. Retrieved from [http://www.earth-auroville.com/compressed\\_stabilised\\_earth\\_block\\_en.php](http://www.earth-auroville.com/compressed_stabilised_earth_block_en.php)
- Auroville. (n.d.). *Compressed stabilised earth blocks*. Mutter, India: Auroville .
- Awareness, I. (2011). PASSA - Participatory Approach for Safe Shelter.
- Bambus. (2002, October 27). *Mechanical properties of bamboo*. Retrieved from Bambus: [https://static1.squarespace.com/static/53407b1de4b05fdb12d8f4a7/t/536252b5e4b0fcd157661f25/1398952629903/mechanical\\_properties\\_of\\_bamboo.pdf](https://static1.squarespace.com/static/53407b1de4b05fdb12d8f4a7/t/536252b5e4b0fcd157661f25/1398952629903/mechanical_properties_of_bamboo.pdf)
- Bhatterai, K. (2016). *Nepal's Unending Political Instability*. Retrieved March 2017, from Nepal's power tussle is overshadowing pressing national issues: <http://thediplomat.com/2016/07/nepals-unending-political-instability/>
- Billingsley, K. (2016). *Structural Inequality and Disaster Management in Nepal*. Tennessee: Department of Anthropology, Disasters, Displacement and Human Rights Program Center for the Study of Youth and Political Conflict, University of Tennessee Knoxville.
- Bisri, M. B. (2016). Analyzing the National Disaster Response Framework and Inter-Organizational Network of the 2015 Nepal/Gorkha Earthquake. *Procedia Engineering*, 159, 19-26.

- Bowles, J. E. (1996). *Foundation Analysis and Design (5th Edition)*.
- Bryson, J. M. (2004). *What to do when stakeholders matter- Analysis Techniques*, 6(1), 21–53.
- BuildUpNepal. (2016). *Earth brick engineer report*. Kathmandu: Build up Nepal.
- Butcher, J. (2006). The United Nations International Year of Ecotourism: A Critical Analysis of Development Implications. *Progress in Development Studies* 6 (2), 146–156.
- Casagrande, A. (1952). *Unified Soil Classification System*.
- Cascone, E., & Casablanca, O. (2016). *Static and seismic bearing capacity of shallow strip footings*. Agata Messina, Italy: Elsevier.
- CDPS. (2015). *Nepal Earthquake 2015 : A Socio-Demographic Impact Study*. (Central Department of Population Studies) Retrieved from [http://nepal.iom.int/jupgrade/images/stories/CoM/NEQ\\_Study\\_Report\\_Final\\_24May2016.pdf](http://nepal.iom.int/jupgrade/images/stories/CoM/NEQ_Study_Report_Final_24May2016.pdf)
- CDSP. (2015). *Nepal Earthquake 2015: A Socio-Demographic Impact Study*. Central Department Population Studies (CDPS), Tribhuvan University for the Ministry of Population and Environment (MoPE) with support from the United Nations.
- Centre, U. N. (2015). Retrieved from <http://www.un.org.np/resources/maps>
- Chamlagain, D. (2009). Earthquake scenario and recent efforts toward earthquake risk reduction in Nepal. *Journal of South Asia Disaster Studies*, 2(1), 57-80.
- CIA. (2015). *The World Factbook: Nepal*. Retrieved from <https://www.cia.gov/library/publications/the-world-factbook/geos/np.html>
- Construction, D. o. (2017). *Functions*. Retrieved May 2017, from <http://www.dudbc.gov.np/about-dudbc/functions>
- Dave Hodgkin, F. P. (2016). *Bamboo in Nepal* . Kathmandu : HBC.
- Department of Urban Development and Building Construction*. (n.d.). Retrieved May 2017, from [www.dudbc.gov.np](http://www.dudbc.gov.np): <http://www.dudbc.gov.np/about-dudbc/functions>
- Dijkshoom, K., & Huting, J. (2009). *Soil and Terrain database for Nepal*. ISRIC World Soil Information.
- Dyson, R. G. (2004). Strategic development and SWOT analysis at the University of Warwick. *European journal of operational research*, 152(3), 631-640.
- EN.1997-1. (2004). *Eurocode 7: Geotechnical design - Part 1: General rules*.
- Fan, C., & Fan, H. (n.d.). *Test Methods for Determination of Mechanical Properties of Bamboo*. Harbin University of Civil Engineering and Architecture.
- Farm, K. (n.d.). *Methods of preserving bamboo*. Retrieved from Kitil Farm : [http://www.kitilfarm.com/bamboo\\_preserving.php](http://www.kitilfarm.com/bamboo_preserving.php)
- Fellenius, B. H. (2006). *Basics of Foundation Design* . Calgary, Alberta, Canada.
- FromTheGroundUp. (2016). *HI CSEB*. Retrieved from DOCPLAYER: <http://docplayer.net/33071608-Hi-cseb-from-the-ground-up.html>
- Geale, S. (2012). The ethics\_of disaster management. *Disaster Prevention and Management*, 21(4):445-462 . Retrieved from

- [https://www.researchgate.net/publication/235274778\\_The\\_ethics\\_of\\_disaster\\_management](https://www.researchgate.net/publication/235274778_The_ethics_of_disaster_management)
- Goda, K., Kiyota, T., Pokhrel, R., Chiaro, G., Katagiri, T., Sharma, K., & Wilkinson, S. (2015). The 2015 Gorkha Nepal earthquake: insights from earthquake damage survey. *Front. Built Environ.*
- Godbole, V., & Lakkad, S. (1986). *Effect of Water-Absorption on the Mechanical Properties of Bamboo*. Bombay: Chapman Hall Ltd.
- Habitat for Humanity*. (2017). Retrieved from <https://www.habitat.org/where-we-build>
- Habitat for Humanity*. (2017). (How to support Habitat for Humanity Halton-Mississauga) Retrieved from <https://www.habitathm.ca/single-post/How-to-Support-Habitat-for-Humanity-Halton-Mississauga>
- HBC. (2013). *Bamboo in Nepal*. Kathmandu, Nepal : Humanitarian bamboo .
- Inbar. (2015). *Nepal Gears up to Build Earthquake resistant structures using bamboo* . Retrieved from Inbar news : <http://www.inbar.int/nepal-gears-up-to-build-earthquake-resistant-structures-using-bamboo/>
- International Organization for Migration*. (2017). Retrieved from [www.iom.int](http://www.iom.int): <https://www.iom.int/about-iom>
- Ipinge, I. (2012). *Durability of compressed stabilised earth blocks*. Sandton: University of the Witwatersrand.
- IS.1498.1970. (2000). *CLASSIFICATION AND IDENTIFICATION OF SOILS FOR GENERAL ENGINEERING PURPOSES*.
- Janssen, J. J. (2000). *Designing and Building With Bamboo*. International Network for Bamboo and Rattan .
- Jones, S. O. (2014). Governance struggles and policy processes in disaster risk reduction: A case study from Nepal. *Geoforum*, 57, 78-90.
- Lee, A. (2016). Barriers to evidence-based disaster management in Nepal: a qualitative study. *Public health*, 133, 99-106.
- Li, X. (2004). *Physical, Chemical and Mechanical Properties of Bamboo and its Utilization Potential for Fireboard Manufacturing* . Beijing .
- Mahzuz, H. M. (2013). *Determination of Several Properties of a Bamboo of Bangladesh*. Bangladesh: Journal of Civil Engineering Research.
- Maplecroft. (2011). *Climate Change Vulnerability Index 2011. vol 2015*.
- Maylor, H. (2010). *Project Management*. Harlow: Pearson. Retrieved from <https://doi.org/10.1097/00124645-200307000-00007>
- Mbuge, D. O. (2000). *Mechanical Properties of Bamboo (Bambusa Vulgaris) Grown in Muguga, Kenya*. Nairobi.
- Mellagard, H. (2016). *Compressed stabilised earth blocks in Nepal*. Retrieved from <http://publications.lib.chalmers.se/records/fulltext/248154/248154.pdf>
- Ministry of Finance, N. (2016). *Nepal: Economic Survey 2015/2016*.

- Murray-Webster, R. &. (2006). Making sense of stakeholder mapping. *PM World today*, 8(11), 1-5.
- Naik, P. N. (2012). *Mechanical and Physico-Chemical Properties of Bamboos carried out by Aerospace Engineering Department*. Bombay. Retrieved from [users.telenet.be/jeffstubble/thesis/images/mechanicaltesting.pdf](http://users.telenet.be/jeffstubble/thesis/images/mechanicaltesting.pdf)
- Nepal Corruption Rank*. (2017). Retrieved from Trading Economics: [www.tradingeconomics.com/nepal/corruption-rank](http://www.tradingeconomics.com/nepal/corruption-rank),
- Nepal, N. (2015). *Nepal Earthquake 2015: Post Disaster Needs Assessment*. Kathmandu: National Planning Commission.
- Nicholas, J. M. (2012). Project Management for Engineering, Business, and Technology. Project Management for Engineering, Business, and Technology (4th ed.). Oxon: Routledge. Retrieved from <https://doi.org/10.1016/B978-0-08-096704-2.50030-2>
- Obrzud, R., & Truty, A. (2012). *THE HARDENING SOIL MODEL - A PRACTICAL GUIDEBOOK*.
- Ozer, M. (2012). *Comparing Methods for Predicting Immediate Settlement of Shallow Foundations on Cohesive Soils Based on Hypothetical and Real Cases*.
- Pant, R. R. (2016). *Laboratory Test Results Stabilised Earth Brick*. Kathmandu, Nepal: Central Material Testing Laboratory.
- Prasad, D. S. (2013). *Bearing Capacity of Soil*.
- Red Cross unhappy with govt's NGO policy on reconstruction*. (n.d.). Retrieved December 2017, from <http://www.myrepublica.com/news/10610>
- Regmi, K. D. (2016). The political economy of 2015 Nepal earthquake: some critical reflections. *Asian Geographer*, 33(2), 77-96.
- Regmi, K. D. (2016). The political economy of 2015 Nepal earthquake: some critical reflections. *Asian Geographie*, 33(2), 77-96.
- Regmi, K. D. (2016). The political economy of 2015 Nepal earthquake: some critical reflections. *Asian Geographer*, 33(2), 77-96.
- Sapkota, P. K. (2016). Social production of vulnerability to climate change in the rural middle hills of Nepal. *Journal of Rural Studies*, 48, 53-64.
- Sharma, E. S. (2016). *Build up Nepal*. Retrieved from <http://www.buildupnepal.com/>: <http://www.buildupnepal.com/wp-content/uploads/2017/04/DESIGN-CATALOGUE-VOLUME-II-FINAL.pdf>
- Shrestha, S. &. (2017). *Handmade Houses for the Ex-Kamaiyas: A Pattern Language for the Production of Low-Cost Self-Help Housing in the Western Terai Regions of Nepal Paperback*.
- Simoës, A. (n.d.). *The Observatory of Economic Complexity. Nepal*. Retrieved from <http://atlas.media.mit.edu/nl/profile/country/npl/>
- Social Welfare Council, N. (2017). *NGOs affiliated with Social Welfare Council*. Retrieved from [http://www.swc.org.np/wp-content/uploads/2016/01/SWC\\_NGOs\\_2034\\_071-asadh\\_-Final-in-bhadra-2072.pdf](http://www.swc.org.np/wp-content/uploads/2016/01/SWC_NGOs_2034_071-asadh_-Final-in-bhadra-2072.pdf)



- Sowman, M. &. (1998). *A place called home: Environmental issues and low-cost housing*. Cape Town: University of Cape Town Press.
- SSN4. (2017). *Shock Safe Nepal Team four*. Delft, the Netherlands: TU Delft.
- Statistics, C. B. (2016). Retrieved from Annual Household Survey 2014/15 (Vol. 15): [http://cbs.gov.np/image/data/2016/Annual Household Survey Report](http://cbs.gov.np/image/data/2016/Annual%20Household%20Survey%20Report)
- Statistics, C. B. (2017). *Poverty & Labour*. Retrieved from [http://cbs.gov.np/sectoral\\_statistics/poverty](http://cbs.gov.np/sectoral_statistics/poverty)
- Statistics, C. B. (2017). *Environment*. Retrieved from [http://cbs.gov.np/sectoral\\_statistics/Environment](http://cbs.gov.np/sectoral_statistics/Environment)
- tu-braunschweig*. (n.d.). Retrieved January 2017, from <https://www.tu-braunschweig.de/Medien-DB/geoekologie/nepal-palikhe.pdf>
- Vaessen, M., & Janssen, J. (1997). *Analysing of the Critical Length of Culms of Bamboo in Four-Point Bending Tests*. Eindhoven.
- Van de Poel, I. &. (2011). *Ethics, Technology and Engineering. An introduction*. Wiley-Blackwell, Ed.
- Verruijt, A. (2012). *Soil Mechanics*. Delft University of Technology.
- Visit Nepal*. (2012). Retrieved from [://www.visitnepal.com/nepal\\_information/ngo\\_in\\_](http://www.visitnepal.com/nepal_information/ngo_in_)
- Wehrich, H. (1982). The TOWS matrix—A tool for situational analysis. *Long range planning*, . 15(2), 54-66.
- WorldBank. (2017). *Nepal*. Retrieved from <http://data.worldbank.org/country/nepal>
- Zaidi, A. M. (2010). *A brief review of Compressed Strabilized Earth Brick (CSEB)*. Malaysia : National Defense University of Malaysia .





**APPENDIX I.**  
**Technical**



- distributed voids, deep < 2 mm aproximately
- surface damages, 2 mm < deep < 5 mm aproximately
- localised deep damages, > 5 mm aproximately

10 mm 100 mm



10 mm 100 mm

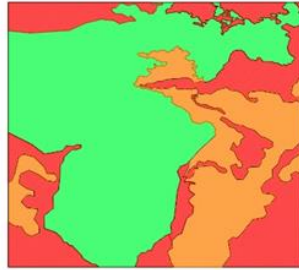

10 mm  
90 mm



10 mm 100 mm



10 mm 100 mm

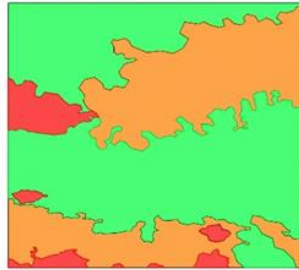

10 mm  
90 mm



10 mm

10 mm

10 mm 100 mm



10 mm 100 mm

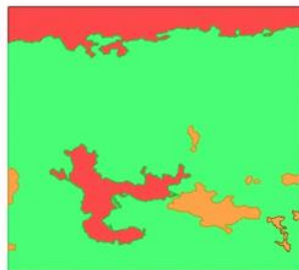

10 mm  
90 mm



BLOCK	SIDE	POINT	HAMMER 1	HAMMER 2
1	U	1	18	21
		2	20	17
		3	18	23
		4	17	24
		5	28	30
		6	18	22
		7	24	28
		8	24	27
		9	21	28
	B	1	21	24
		2	21	27
		3	21	21
		4	21	21
		5	25	29
		6	25	29
		7	20	23
		8	19	22
		9	19	22

BLOCK	SIDE	POINT	HAMMER 1	HAMMER 2
1	R	1	21	26
		2	26	25
		3	19	21
		4	23	26
		5	22	25
		6	21	28
		7	17	18
		8	17	18
		9	19	26

Figure 107: Schmidt hammers used for testing concrete block 1

BLOCK	SIDE	POINT	HAMMER 1	HAMMER 2	
2	U	1	18	21	
		2	20	26	
		3	15	18	
		4	16	11	
		5	18	25	
		6	16	19	
		7	14	18	
		8	18	24	
		9	18	24	
		1	*	*	
		2	18	24	
		3	*	*	
		4	*	*	
		B	5	*	*
			6	*	*
	7		16	24	
	8		*	*	
	9		*	*	
	1		*	*	
	2		*	*	
	3		*	*	
	4		*	*	
	R		5	18	26
			6	*	*
			7	*	*
		8	*	*	
		9	*	*	

Figure 108: Schmidt hammers used for testing concrete block 2

BLOCK	SIDE	POINT	HAMMER	HAMMER
			1	2
		1	23	28
		2	22	27
		3	18	20
		4	21	23
	U	5	21	29
		6	19	28
		7	20	21
		8	21	30
		9	21	23
		1	18	24
		2	21	24
		3	18	21
3		4	20	28
	B	5	26	25
		6	24	27
		7	22	24
		8	16	22
		9	*	*
		1	18	24
		2	20	26
		3	20	22
		4	*	*
	R	5	24	27
		6	20	28
		7	*	*
		8	19	29

*Figure 109: Schmidt hammers used for testing concrete block 3*

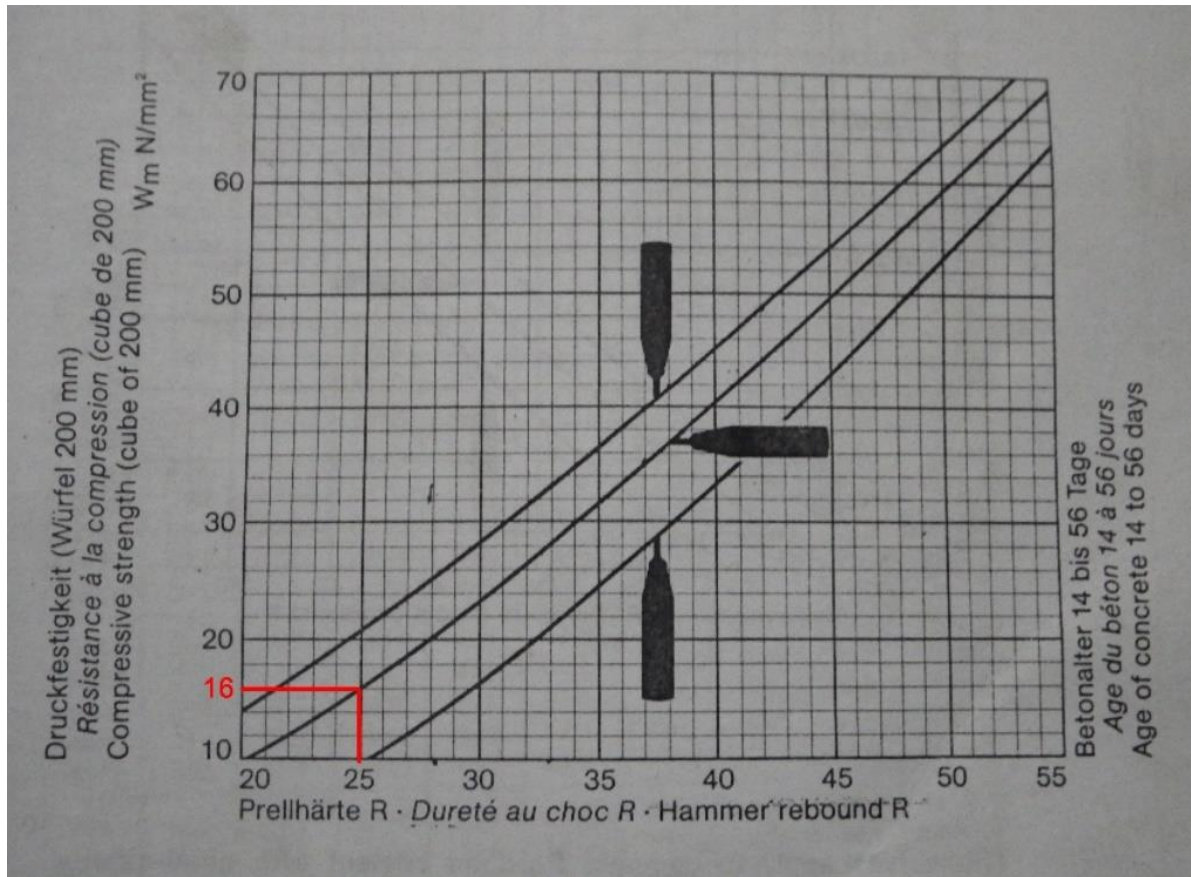

Figure 110: Compressive strength of a 200mm cube and how to define the strength of it with the Schmidt hammer



# EXAMPLE OF PGA FOR COLLAPSE INITIATION – XL FILE

INPUT	WALL GEOMETRIC DIMENSIONS					
	wall thickness $s$ [m]	height of wall compartment $h$ [m]	distance of application point for upper loads due to upper levels $d$ [m]	$d_v$ [m]	$h_v$ [m]	distance of application point for upper loads due to floors $a$ [m]
	0,15	1,20	0,33	0,03	1,50	
INPUT	LOADS					
	specific weight of the wall material $\gamma$ [kN/m <sup>3</sup> ]	self weight of the wall $W$ [kN]	floor loads $P_s$ [kN]	upper levels loads $N$ [kN]	arches loads vertical $F_v$ [kN]	arches loads horizontal $F_H$ [kN]
	20,00	3,60		31,45	18,45	10,60

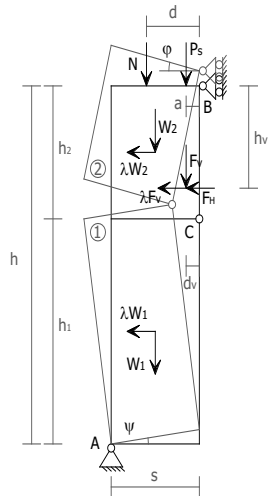
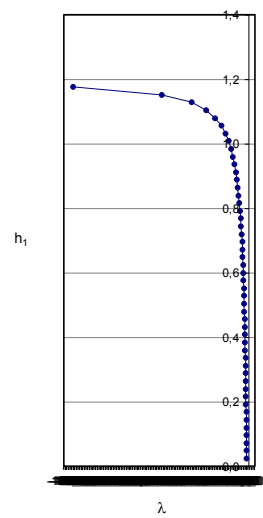

Fig. 1 - static scheme

Variation of  $\lambda$  depending on the height of the middle rotation point C



acceleration factor $\lambda$				
minimum $\lambda$	$h_1$ related to the minimum gamma [m]	$\lambda$ if $h_2 = h_v$	hinge height $h_1$ [m]	minimum $\lambda$
-151,892	1,18	-1,412	1,18	-151,892

PGA	mass that collaborates to the cinematics $M^*$	collaborative mass fraction $e^*$	spectrum acceleration $a_0^*$ [m/sec <sup>2</sup> ]	height of the wall from the foundation $H$ [m]	height of the base of the walls from the foundation [m]	height of weight forces barycenter $Z$ [m]	soil factor $S$	structure factor $q$	PGA of collapse (SLU)
	0,410	0,182	-8169,416	7,00	0,00	-0,15	1,25	2,00	-1377,606

Figure 111: EXAMPLE OF PGA FOR COLLAPSE INITIATION

R	14-56 Days						7 Days					
	W <sub>m</sub>			W <sub>min</sub>			W <sub>m</sub>			W <sub>min</sub>		
	kp/cm <sup>2</sup>	N/mm <sup>2</sup>	psi	kp/cm <sup>2</sup>	N/mm <sup>2</sup>	psi	kp/cm <sup>2</sup>	N/mm <sup>2</sup>	psi	kp/cm <sup>2</sup>	N/mm <sup>2</sup>	psi
20	101	9.9	1440	54	5.3	770	121	11.9	1720	74	7.3	1050
21	113	11.1	1610	64	6.3	910	132	12.9	1880	83	8.1	1180
22	126	12.4	1790	75	7.4	1070	145	14.2	2060	94	9.2	1340
23	139	13.6	1980	86	8.4	1220	157	15.4	2230	104	10.2	1480
24	152	14.9	2160	98	9.6	1390	169	16.6	2400	115	11.3	1640
25	166	16.3	2360	110	10.8	1560	183	18.0	2600	127	12.5	1810
26	180	17.7	2560	122	12.0	1740	196	19.2	2790	138	13.5	1960
27	195	19.1	2770	135	13.2	1920	210	20.6	2990	150	14.7	2130
28	210	20.6	2990	149	14.6	2120	225	22.1	3200	164	16.1	2330
29	225	22.1	3200	163	16.0	2320	239	23.4	3400	177	17.4	2520
30	241	23.6	3430	178	17.5	2530	254	24.9	3610	191	18.7	2720
31	257	25.2	3660	193	18.9	2750	269	26.4	3830	205	20.1	2920
32	274	26.9	3900	209	20.5	2970	285	28.0	4050	220	21.6	3130
33	291	28.5	4140	225	22.1	3200	300	29.4	4270	234	23.0	3330
34	307	30.1	4370	240	23.5	3410	315	30.9	4480	248	24.3	3530
35	324	31.8	4610	256	25.1	3640	331	32.5	4710	263	25.8	3740
36	342	33.5	4860	273	26.8	3880	348	34.1	4950	279	27.4	3970
37	360	35.3	5120	290	28.4	4120	365	35.8	5190	295	28.9	4200
38	377	37.0	5360	307	30.1	4370	381	37.4	5420	311	30.5	4420
39	395	38.7	5620	324	31.8	4610	398	39.0	5660	327	32.1	4650
40	413	40.5	5870	341	33.4	4850	416	40.8	5920	344	33.7	4890
41	432	42.4	6150	359	35.2	5110	434	42.6	6170	361	35.4	5130
42	450	44.1	6400	377	37.0	5360	451	44.2	6410	378	37.1	5380
43	469	46.0	6670	395	38.7	5620	470	46.1	6690	396	38.8	5630
44	488	47.9	6940	414	40.6	5890	488	47.9	6940	414	40.6	5890
45	507	49.7	7210	432	42.4	6140	507	49.7	7210	432	42.4	6140
46	526	51.6	7480	451	44.2	6410	526	51.6	7480	451	44.2	6410
47	546	53.5	7770	470	46.1	6690	546	53.5	7770	470	46.1	6690
48	565	55.4	8040	489	48.0	6960	565	55.4	8040	489	48.0	6960
49	584	57.3	8310	508	49.8	7230	584	57.3	8310	508	49.8	7230
50	604	59.2	8590	527	51.7	7500	604	59.2	8590	527	51.7	7500
51	623	61.1	8860	546	53.5	7770	623	61.1	8860	546	53.5	7770
52	643	63.1	9150	565	55.4	8040	643	63.1	9150	565	55.4	8040
53	663	65.0	9430	584	57.3	8310	663	65.0	9430	584	57.3	8310
54	683	67.0	9710	603	59.1	8580	683	67.0	9710	603	59.1	8580
55	703	68.9	10000	622	61.0	8850	703	68.9	10000	622	61.0	8850

Figure 112:: Cube compressive strength as a function of the Rebound's number R



TAX INVOICE

# MRS Enterprises

Tripureshwor Kathmandu, Tel: 4101129

Invoice No.: **478**

VAT No.: 304723827

M/S: ..... Transaction Date: .....

Address: ..... Issue Date: .....

Buyer's VAT/PAN No.: [ ] [ ] [ ] [ ] [ ] [ ] [ ] [ ]

*2073/11/19*

Mode of Payment: Cash/Credit/Cheque/Others

S. No.	Particulars	Qty.	Rate	Amount
1	Boric Acid 500gm	2.304	648	1296.
2	Borax Powder 500gm	2.132	626	1352
				<b>2</b>

Rs. in Words: <i>Rs. Two thousand</i>	SubTotal	<i>2648.</i>
<i>one hundred ninety two</i>	Discount	-
<i>\$ Perse. purity amount</i>	Taxable Amount	<i>2648.-</i>
	% VAT	<i>344.24</i>
	GRAND TOTAL	<i>2992.24</i>

E. & O.E. \_\_\_\_\_  
 Received by: ..... For: MRS Enterprises *[Signature]*

Figure 113: Total costs Borax en Boric acid

The total costs of the borax and boric acid for the preservative is 2992,- NPR or 26.72 EUR per 2 kg.



Mr. Focco - Vons				11/17
1	Connection Pipe 1/2"	5	250	1250
2	GI Flange 1/2"	1	274	274
3	Ball Valve 1/2" Gasi	2	330	660
4	CPVC Male Socket Cap	12	29	348
5	Brass O-ring 1/2"	2	55	110
6	Thread Seal Tape	3	20	60
7	CPVC Solvent 50ml	2	537	1074
8	CPVC Flange 1/2"	4	529	2116
9	CPVC Elbow 1/2"	4	34	136
10	CPVC Tee 1/2"	5	40	200
11	CPVC Pipe 1/2"	2	206	412
12	CPVC Union 1/2"	2	240	480
13	CP Hex Nut 1/2"	5	85	425
14	Group 1/2" x 3	1	2295	2295
15	Pressure Gauge	1	550	550
				8117,95
2040 - 2022,95				len. 2574,95
2289 - 308				5540

E3/11/17				
1	Ag. Release Nut	4	250	1000
2	CPVC R/Socket 2x3/4	5	328	1640
3	CPVC R/Bust 2x1/2	5	20	100
4				/
5				2740
6			le	1240
7				1500
8	CPVC Pipe 1/2"	h	678	239
9				1839
10			le	152
11				
12				
13				
14				
15				
				1687
				1500

Figure 114: Total costs bucherie machine

The total costs of the material to build the bucherie machine is 7227,- NPR or 65.54 EUR.

Cement content		5%			
Sand content		55%	50%	45%	
Clay		10%	15%	20%	
Gravel		15%	15%	15%	
Silt		15%	15%	15%	
Results					
2 days of treatment	Block fail after	# blocks / kg	# blocks / kg	# blocks / kg	
		# blocks / kg	# blocks / kg	# blocks / kg	
		# blocks / kg	# blocks / kg	# blocks / kg	
		# blocks / kg	# blocks / kg	# blocks / kg	
5 days of treatment	Block fail after	# blocks / kg	# blocks / kg	# blocks / kg	
		# blocks / kg	# blocks / kg	# blocks / kg	
	Drop test	[m]	[m]	[m]	
		[m]	[m]	[m]	
Compression test	MPa	MPa	MPa		
	MPa	MPa	MPa		
7 days of treatment	Drop test	[m]	[m]	[m]	
		[m]	[m]	[m]	
	Compression test	MPa	MPa	MPa	
		MPa	MPa	MPa	
14 days of treatment	Drop test	MPa	MPa	Mpa	
		MPa	MPa	MPa	
	Compression test	MPa	MPa	MPa	
		MPa	MPa	MPa	
21 days of treatment	Compression test	MPa	MPa	MPa	
		MPa	MPa	MPa	
		Mpa	Mpa	Mpa	
		MPa	MPa	MPa	
Final strength (average of 21 days compression test)		MPa	MPa	MPa	

Figure 115: CSEB dropping test



Pictures of the bamboo treatment training







Figure 116: Pictures of the bamboo treatment training





## Appendix II. Context

# II.A Stakeholder Analysis

STAKEHOLDER	ACR	TYPE	DESCRIPTION	POWER	INTER EST	ATTIT UDE	BLOCKING POWER	POWER	INTEREST	PROBLEM PERCEPTION	GOAL	COLLABORATION	CONFLICT
General Government of Nepal	GoN	Government	Government on national level, responsible for legislation CL-PIU	+++	-	-	Yes	High power due to their blocking power as a legislative body	Wasting funding and controlling and monitoring rebuilding	Lack of internal structure, unclear responsibility and complex responsibility	Respecting rights, security and welfare for the society of Nepal	HRRP, research institutes, Go India, Go China	NGOs concerning funding, Go India, Go China
Central Level Project Implementation Unit	CL-PIU	Government	Central level authority, responsible for legislation CL-PIU organization since designs are handed in for approval on national level	++	-	-	Yes	High power due to their blocking power as a legislative body	Regulate the designs and materials in CL-PIU and coordinate with DUDBC on national level	Lack of technical knowledge and knowledge sharing	Mission to expedite the reconstruction of houses affected from the devastating earthquake activities with continuous and aggressive coordination and communication	Coordinating forums, GOs, NGOs, & NGOs, design experts and other development partners	NGOs concerning legislation of designs
District Level Project Implementation Unit	DL-PIU	Government	Established under CL-PIU in the 14 most affected districts. Responsible for legislation DL-PIU organization where designs are handed in for approval on district level and responsible for technical assistance	+	-	-	Yes	High power due to their blocking power as a legislative body	Regulate the designs and materials in the NSC and design catalogue in collaboration with DUDBC on district level	Lack of technical knowledge and knowledge sharing	Mission to expedite the reconstruction of houses affected from the devastating earthquake projects at the district level if they cannot approve it	CL-PIU (designs go from DL-PIU to CL-PIU if they cannot approve it)	NGOs concerning legislation of designs
Village Development Committees	VDC	Government	Responsible for municipality level	+	-	-	Yes	Their power is less than the CL-PIU, however only one house specific, in the VDC. Have to send designs to CL-PIU for approval and not to VDC	Can approve building design if design is in the design catalogue and building code approve for one household	Do not have experts, such as to send designs to CL-PIU for approval	Regulating development, justice, security and safety of houses affected from the devastating earthquake projects by being directly in contact with this village	Speakers NGOs, higher governmental organizations, locals	Higher governmental organizations
Department of Urban Planning & Building Construction	DUDBC	Government	Organizing large scale projects to rebuild Nepal. Besides the reconstruction of houses, focuses on urban development and construction.	++	-	-	Yes	High power since they are a governmental department, however constrained to governmental budgeting.	Responsible for Design Catalogue Vol 1 and 2	Lack of knowledge	Increase and promote safe, feasible and resilient building designs with respect to traditional or building designs with respect to traditionalism	HRRP, NRA, NGOs, research institutes to gain more knowledge for the legislation	NRA, NSET, NGOs
National Reconstruction Authority	NRA	Government	Organization that is set up after the earthquake in 2015, responsible for leading and managing recovery and the reconstruction programme in a sustainable and planned manner. Has developed a long term development strategy for Nepal (Envisioning Nepal 2035)	++	+	+	Yes	High power, because part of government and they created PIU which created PIU.	Structured approach towards the knowledge through research and educational institutes.	Lack of supplies, technical assistance and knowledge.	Oversee all reconstruction activities after the earthquake to direct the process in general	HRRP, DUDBC, Tribhuvan University, CL-PIU, DL-PIU	NGOs, DUDBC
National Planning Commission	NPC	Government	Apex advisory body of the government on vision, strategies and policies. Assesses resource needs, identifies sources of funding, and allocates budget for socio-economic development. Has developed a long term development strategy for Nepal (Envisioning Nepal 2035)	+/-	+	+	Yes	Medium/high power: the NPC is an advisory body, but the highest of the GoN.	Advising the GoN, sharing information, functioning as an intellectual hub regarding development topics.	Getting knowledge to the implementation of the knowledge	Only research, therefore low power regarding implementation of the knowledge	GoN as they advise them on planning, development partners	GOA, as they advise them but not the planning sector
TU Datt	TUD	Research/Know edge	Educate, knowledge and research institute focused on engineering	+++	-	++	No	Low since universities function as a knowledge/research institute.	Increasing welfare by giving education and expanding the board areas of knowledge by giving education and expanding the board areas of knowledge in a society, not directly involved in research into reconstruction.	Only research, therefore low power regarding implementation of the knowledge	Through SSN research on earthquake resilient housing in Nepal	Tribhuvan University to exchange knowledge through SSN	VDC, DL-PIU, CL-PIU implementation of building design and getting design approval.
Tribhuvan University		Research/Know edge	Educate, knowledge/research institute focused on engineering, based in Nepal	+++	-	++	No	Medium since universities function as a knowledge/research institute	HRRP supports government authorities (NRA, DUDBC, DL-PIU, CL-PIU) in facilitating cooperation with the national and international organizations, the (farm families) and public associations involved in recovery and reconstruction by IOM and UNHABITAT, as of the beginning of JANUARY 2016.	Only research and as advisory body for the NRA, regarding implementation of the knowledge	Research on earthquake resilient housing in Nepal	NRA, DUDBC to give knowledge about SSN and TU Datt through SSN to exchange knowledge	NRA, DUDBC by not taking the advice
Health, Recovery, and Reconstruction Platform - Nepal	HRRP	Information platform	HRRP is a platform for coordination, strategic planning and reconstruction and to support the Government of Nepal in coordinating the national reconstruction programme.	-/+	+	++	No	Medium power, as it is a platform umbrella organization	Keeping track of NGO's working in Nepal	No transparency, NGOs for example do not share their knowledge and not have all information to share as platform.	It is transparent and share all knowledge regarding earthquake resilient building with all affected and interested parties.	HRRP, DUDBC, CL-PIU, DL-PIU, Local people through district offices	GOA, NRA, DUDBC, NGO's as they are transparent and share all knowledge with these and are a collective voice of stakeholders to the government.
Social Welfare Council	SWC	Information platform	All NGOs have to be registered under this organization	-/+	+	++	No	Medium power, as it is an inter-organizational body, works closely with UN and chairman is prime minister	Keeping track of NGO's working in Nepal	Lack of clarity about NSC, building catalog and new building catalog and new ones that long in Nepal as it does not compared to other NGOs.	Clearly being drafted and submitted to the government for approval, and social registry registration benefits migrants and society.	Nations (UN) at several levels.	GOA, DUDBC - if agreements about use of funding cannot be made due to regulation from the government
Intersectoral Commission for Migration (IOM Migration Agency)	IOM	IGO	Leading inter-governmental organization in the field of migration	+	-	+	Yes	Medium power, as they have a strong foundation in technical and scientific experience, being a branch of Engineers Without Borders	Trying to create a network where all knowledge is shared and actors strengthen each other.	Lack of clarity about NSC, building catalog and new building catalog and new ones that long in Nepal as it does not compared to other NGOs.	Implementing housing in affected areas in certain districts in Nepal.	NRA, DUDBC, Tribhuvan University	CL-PIU and DL-PIU as ASF is the implementation of the regulation from the government cannot be met due to regulation from the government
Architects sans frontiers	ASF	NGO	Aiming to contribute to the sustainable development of disadvantaged communities in Nepal by sharing technical and scientific expertise, thereby helping communities improve the quality of their lives	-/+	+	++	No	Medium power, as they have a strong foundation in technical and scientific experience, being a branch of Engineers Without Borders	Trying to create a network where all knowledge is shared and actors strengthen each other.	Lack of clarity about NSC, building catalog and new building catalog and new ones that long in Nepal as it does not compared to other NGOs.	Implementing housing in affected areas in certain districts in Nepal.	NRA, DUDBC, Tribhuvan University	CL-PIU and DL-PIU as ASF is the implementation of the regulation from the government cannot be met due to regulation from the government

STAKEHOLDER	ACR	TYPE	DESCRIPTION	POWER	INTER EST USE	BLOCKING POWER	POWER	INTEREST	PROBLEM PERCEPTION	GOAL	COLLABORATION	CONFLICT
UN-Habitat	NGO		UN-Habitat envisions well-planned, well-governed, and efficient cities and other human settlements, with adequate housing, services such as water, energy, and sanitation. UNICEF in Nepal mainly focuses in the 15 lowest performing districts of Nepal but our impact is nationwide especially with our services, budget, and resources. We are developing mechanisms that enable the survival, development, protection and participation of children, adolescents and women.	+/-	+	++	No	Promoting shelter for all with emphasis on urban poor and vulnerable population in rural areas. Promoting disaster risk reduction policy level and in implementation. Running humanitarian projects on local level. Promoting local parties to improve local living conditions and giving immediate help when needed. The mission of the Nepal Red Cross is to provide relief and support to reduce vulnerability through community participation and mobilization of an increased number of volunteers, by strengthening the organizational structure of the society and by building links with governmental and non-governmental organizations.	Lack of clarity about NBC, building catalog and grants.	UN-Habitat envisions well-planned, well-governed, and efficient human settlements, with adequate housing, services such as water, energy, and sanitation. Goal is to relieve human suffering and to reduce vulnerability through mobilization of volunteers and participation from communities, organizations, and non-governmental organizations.	Governments, local authorities, NGOs, the private sector, and civil society.	GoN on policy and implementation of funding. The use of funding cannot be met as per regulation from the government.
Unicef	NGO		Nepal Red Cross Society shall remain as efficient, self-sustainable, and independent humanitarian organization committed to provide immediate relief to human suffering and reduce vulnerability, under the Fundamental Principles of the International Red Cross and Red Crescent Movement throughout the country working closely with communities and governmental and non-governmental organizations in a democratic, transparent and participatory way.	+/-	+	++	No	Running humanitarian projects on local level with local parties to improve local living conditions and giving immediate help when needed. "A word where everyone has a deed" to be the motto of UNICEF. Nepal to attract their incentives as well as to promote human rights, social justice and pro-poor development.	Lack of clarity about NBC, building catalog and grants.	Developing community level activities to build the health and well-being of children, but development of an earthquake resilient Nepal after the 2016 Earthquake.	Government, other NSOs	GoN, when policies block them
Nepal Red Cross Society	NRCS	NGO		-	+	++	No	Running humanitarian projects on local level with local parties to improve local living conditions and giving immediate help when needed. "A word where everyone has a deed" to be the motto of UNICEF. Nepal to attract their incentives as well as to promote human rights, social justice and pro-poor development.	Lack of clarity about NBC, building catalog and grants.	Goal is to relieve human suffering and to reduce vulnerability through mobilization of volunteers and participation from communities, organizations, and non-governmental organizations.	Government, other NSOs	Government, Donors - if agreements about use of funding cannot be met due to regulation from the government
Habitat for Humanity	NGO		Non-governmental organization who provides locals with decent housing.	+/-	++	++	No	Low power, as they are dependent on donors for grants, on the government and implementation partners in order to be able to design and implement projects. UNICEF is a political organization, however politically non-partisan organization. Medium power, as they are dependent on government functions as a non-governmental functions as a knowledge in the field, however NSET consists of ex-governmental members.	Lack of clarity about NBC, building catalog and grants.	Rebuilding shelter for people of Nepal, reaching those who lost their houses in the earthquake.	Other NGOs, HRPP	DUIBEC, DL-FIU, CL-FIU, Donors - if agreements about use of funding cannot be met due to regulation from the government.
NGO Federation of Nepal	NGO		Umbrella organization for NGOs in the aftermath of democratic political change and establishment of multiparty system.	-	-	+	No	Medium/high power, as they work closely with the government. NCDM is the operational partner with UN and Red Cross as well as other private organizations.	Lack of clarity about NBC, building catalog and grants.	Bringing together NGOs and acting as one representative towards other organizations, fighting for promoting human rights, social justice and pro-poor development.	Other NGOs, HRPP	NGOs
National Society for Earthquake Technology	NSET	NGO	Nepal non-governmental organization working on reducing earthquake risk and increasing earthquake preparedness in Nepal as well as other earthquake prone countries.	+/-	++	+	No	Assess damage, train masons and construction workers, create awareness on disaster reduction, Earthquake Safe Generators nationwide, assesses among the people on disaster risks and their management. Work on the capacity building of local communities on reconstruction. Exploit all available resources to support the UN and Red Cross as well as other private organizations.	Lack of clarity about NBC, building catalog and grants.	Gather information about rebuilding Earthquake resistant.	GoN, HRPP, Research institutes	
Nepal Centre Disaster Management	NCDM	NGO	Helps to effectively mitigate the impact of disasters in the country. The Centre is registered in the Kathmandu District Administration Office. Government of Nepal. NCDM is also operational partner with UN and Red Cross as well as other private organizations. Several projects regarding disaster risk management, including earthquakes, flooding, drought and avalanche.	+	++	+	No	Medium/high power, as they work closely with the government. NCDM is the operational partner with UN and Red Cross as well as other private organizations.	National awareness needs to be improved as well as disaster risk management generating ideas.	Concerned organizations, including the Government, local authorities, and institutions to manage and mitigate the risk of natural or other disasters. Also work on disaster preparedness between the sectors of policies and the government agencies at times of disasters.		
SupportNepal	NGO (local)		Works on improving living standards in Ratanakot and collects funds from Belgium.	-	+	+	No	Low power, as they are only focusing on the village Ratanakot. Have implementing power as they used in many places and a complete idea behind the technique, are useful to NGOs but do not have power over other organizations.	Lack of clarity about NBC, building catalog and grants.	Rebuilding Ratanakot and doing research into the needs of Ratanakot.	GoN, Donors in Europe	GoN - if agreements about use of funding cannot be met due to regulation from the government.
Build Up Nepal	NGO (local)		Works as an implementation partner. Empowering local people using local materials, providing machines and training for rural communities, teaching them to make SCEEB and rebuild their own village together with NGOs and NGOs.	-	+	+	No	Use technology to promote human rights, social justice, mitigation of earthquake resistant measures and pro-poor development in smaller scale areas.	Lack of clarity about NBC, building catalog and grants.	Be the implementing partner for other NGOs who want to rebuild houses in Nepal.		DUIBEC as CSBEB are not in the building code yet
Representatives Ratanakot	Locals		Karma Lama and Shyam Lama who have had a large role in the development of Ratanakot. Shyam regarding development of Ratanakot and Karma regarding funding, knowledge and partner.	-	++	++	No	Promote human rights, social justice, mitigation of earthquake resistant measures and pro-poor development in smaller scale areas.	Lack of money, lack of knowledge, lack of manpower as young generation moves to cities, lack of clarity from government regarding grants.	Rebuild houses in their village.	SupportNepal, SSN, Lof Foundation, VDC	VDC their designs need to be approved by VDC to get government grant.
Inhabitants Ratanakot	Locals		700 people living in Ratanakot where houses are destroyed.	-	++	+/-	No	Being able to live according to their standards and being able to fulfill the needs.	Lack of money, lack of knowledge, lack of manpower as young generation moves to cities, lack of clarity from government regarding grants.	Rebuild houses in their village.	Representative of Ratanakot	VDC their designs need to be approved by VDC to get government grant.
Workers Ratanakot	Locals		People who helped with building the pilot house in Ratanakot, both from surrounding villages and Ratanakot itself.	-	+	+	No	Can money and improve earthquake resistant constructions.	Lack of money, lack of knowledge, lack of manpower as young generation moves to cities, lack of clarity from government regarding grants.	Rebuild houses in their village through their skills.	SupportNepal, Inhabitants of Ratanakot	VDC their designs need to be approved by VDC to get government grant.
Inhabitants surrounding villages of Ratanakot	Locals		7 areas of Ratanakot.	-	++	+/-	No	Being able to live according to their standards and being able to fulfill the needs.	Lack of money, lack of knowledge, lack of manpower as young generation moves to cities, lack of clarity from government regarding grants.	Rebuild houses in their village.	Representative of Ratanakot, SupportNepal, other local NGOs	VDC their designs need to be approved by VDC to get government grant.
Inhabitants villages in other rural areas	Locals		To be informed	-	++	+/-	No	Being able to live according to their standards and being able to fulfill the needs.	Lack of money, lack of knowledge, lack of manpower as young generation moves to cities, lack of clarity from government regarding grants.	Rebuild houses in their village.	Representatives of their village, other local NGOs	VDC their designs need to be approved by VDC to get government grant.

# INVENTORY OF SSN AND PARTNERS

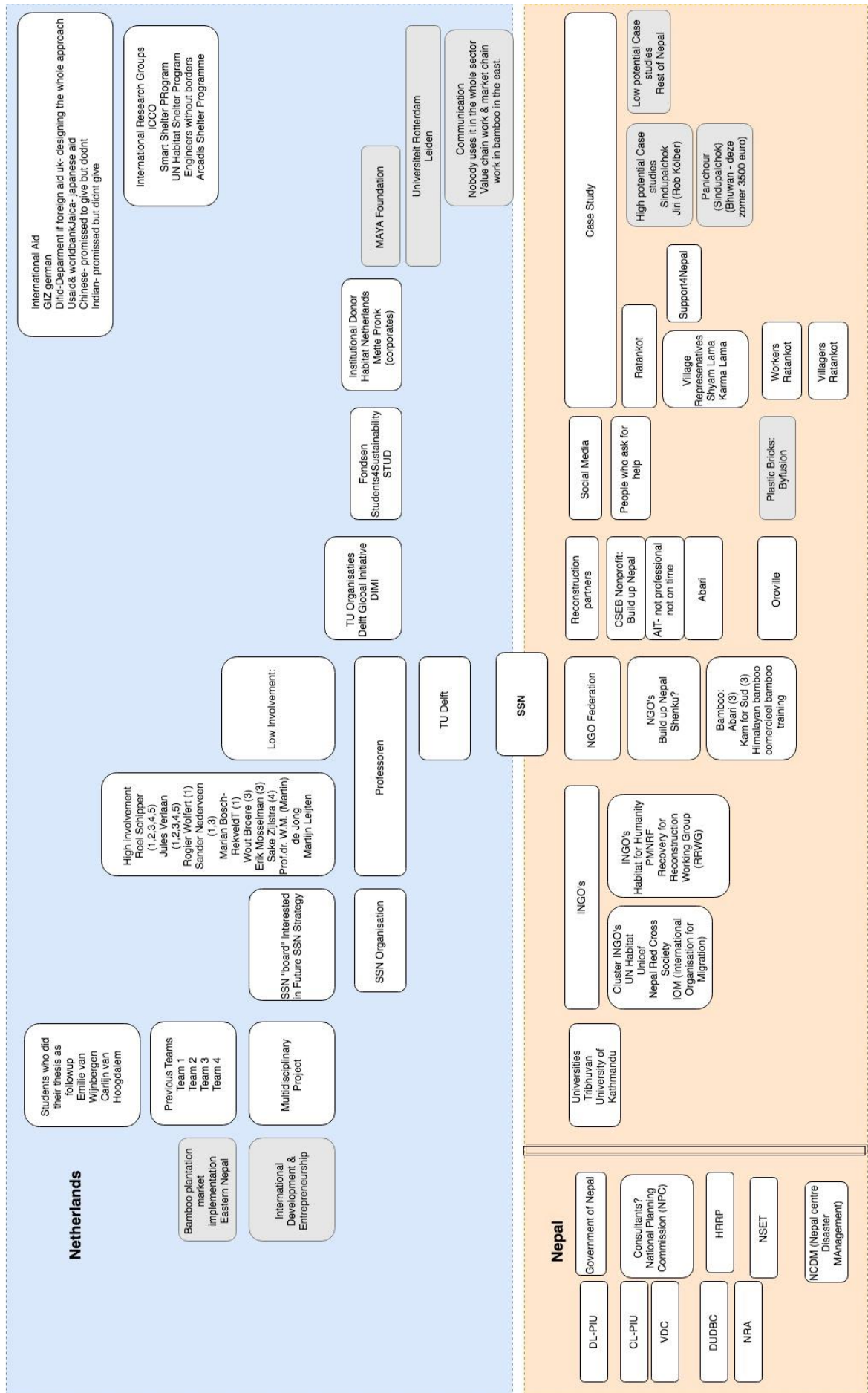



# II.C Risk Assessment

RISK	TYPE	COMPONENTS	ELEMENT	FAILURE MODE	CAUSE	CONSEQUENCE	PROBABILITY (high/medium/low)	IMPACT (high/medium/low)	PRIORITY FOR CURRENT STUDY (H/M/L)	STRATEGY (Transfer/Avoid/Reduce/Accept)	EXTRA	INFLUENCE BY SAFETY	INFLUENCE BIOLOGICAL	INFLUENCE ENVIRONMENTAL	INFLUENCE ECONOMIC	INFLUENCE LEGAL/POLITICAL
E2	External risks	Physical environment	Location	On landscape or hill < 20%	Environment	No safe house	Medium	Medium	Low	Retain	Consumer is bound to land					
E3		Consumer needs	Wishes and needs	Not according to their needs/wishes	Designer/architect	Consumer does not want to live in house	Medium	Medium	Medium	Reduce	Respect the wishes as much as possible, however not harming the structural					
E4		Costs	Price of house	Unaffordable or not willing to pay	Materials supply chain, manpower too expensive	Not possible to build house	High	High	High	Avoid	Use locally available materials and create a design NBC or Design Catalog in order to get funding	X	X	X	X	X
E5		Government's regulations	Building code	No acceptance of design	Not according to NBC	No funding	High	High	High	Avoid	Create a design NBC or Design Catalog in order to get funding				X	X
E6		Labor availability	Manpower	Not enough manpower	No educated people	Low performance building	High	High	Low	Avoid	Technical on site and training sessions	X			X	X
E7		External control	Technical assistance	No technical assistance	No management	House not according to earthquake resistant design	High	High	Low	Avoid	Supervisor (technical assistance)				X	X
D1	Design risks by technicians	Materials	Structural elements	No right dimension of the elements	Lack of technical assistance, knowledge, time	Low performance	Low	High	Medium	Transfer	Research in earthquake resistant building, improve building code	X			X	X
D2				Poor connections structural elements	Lack of technical assistance, knowledge	Low structural performance	High	High	High	Avoid	Technical assistance	X			X	X
D3				Insufficient reinforcement	Lack of technical assistance, knowledge	Low structural performance	Low	High	High	Transfer	Research in earthquake resistant building, improve building code	X			X	X
D4				Wrong type of material (bamboo, steel etc)	Lack of knowledge and locally available materials	Bad in building code thus no funding, low structural performance	Low	Medium	Medium	Transfer	Research in earthquake resistant building, improve building code	X	X	X	X	X
D5				Low quality of components of the material	Lack of technical assistance, availability of materials, time	Low structural performance	High	High	High	Avoid	Technical assistance	X		X	X	X
D6			Secondary elements	-	-	-										
C1	Construction risks by the locals	Materials	Bamboo	Wrong or no treatment	Toxic knowledge/technical assistance, effort, money, time	Low structural performance	High	High	High	Avoid	Technical assistance	X	X		X	
C2				Exposure to different conditions	Tools knowledge/technical assistance, effort	Damaging material	Medium	High	Medium	Avoid or transfer	Avoid cover Transfer: renew material	X		X		
C3				Different type	Environment, other materials, time	Different weight and dimension	Medium	Low	Low	Retain	Too expensive to change type of change type	X		X		X

C4			Lack of knowledge about construction	Knowledge/tech assistance, Environment and time, wrong or no treatment	Low structural performance	High	High	High	High	Avoid	Technical assistance	X	X	X	
C5			Durability	Environment and time, wrong or no treatment	Damaging material so not structurally safe	Medium	Medium	Medium	Medium	Reduce	Improve properties of materials	X	X	X	
C6		Bricks	Low quality/product on	Knowledge/tech assistance, CSEB machine, money	Low structural performance	High	High	High	High	Avoid	Technical assistance, provide CSEB machine through funding	X	X	X	
C7			Lack of knowledge about construction	Knowledge/tech assistance, Environment and time	Low structural performance	High	High	High	High	Avoid	Technical assistance	X	X	X	
C8			Durability	Environment and time	Damaging material so not structurally safe	Low	Low	High	High	Ignore	-	X	X	X	
C9		Concrete	Mixture of concrete	Knowledge/tech assistance, money, tools, available materials	Low structural performance	High	High	Medium	Medium	Avoid	Technical assistance, provide tools, ensure funding	X	X	X	
C10			Lack of knowledge about construction	Knowledge/tech assistance, Environment and time	Low structural performance	High	High	High	High	Avoid	Technical assistance	X	X	X	
C11			Durability	Environment and time	Damaging material so not structurally safe	High	Medium	Medium	Medium	Reduce	Improve properties of materials	X	X	X	

# II.D ADDITIONAL VISUALISATION

## Conclusion diagrams to keep up to date

To further structure the long-term plan of Shock safe Nepal, certain communication diagrams have been created to organise the process. These have helped structure the long-term process and plan and can be of use for following teams

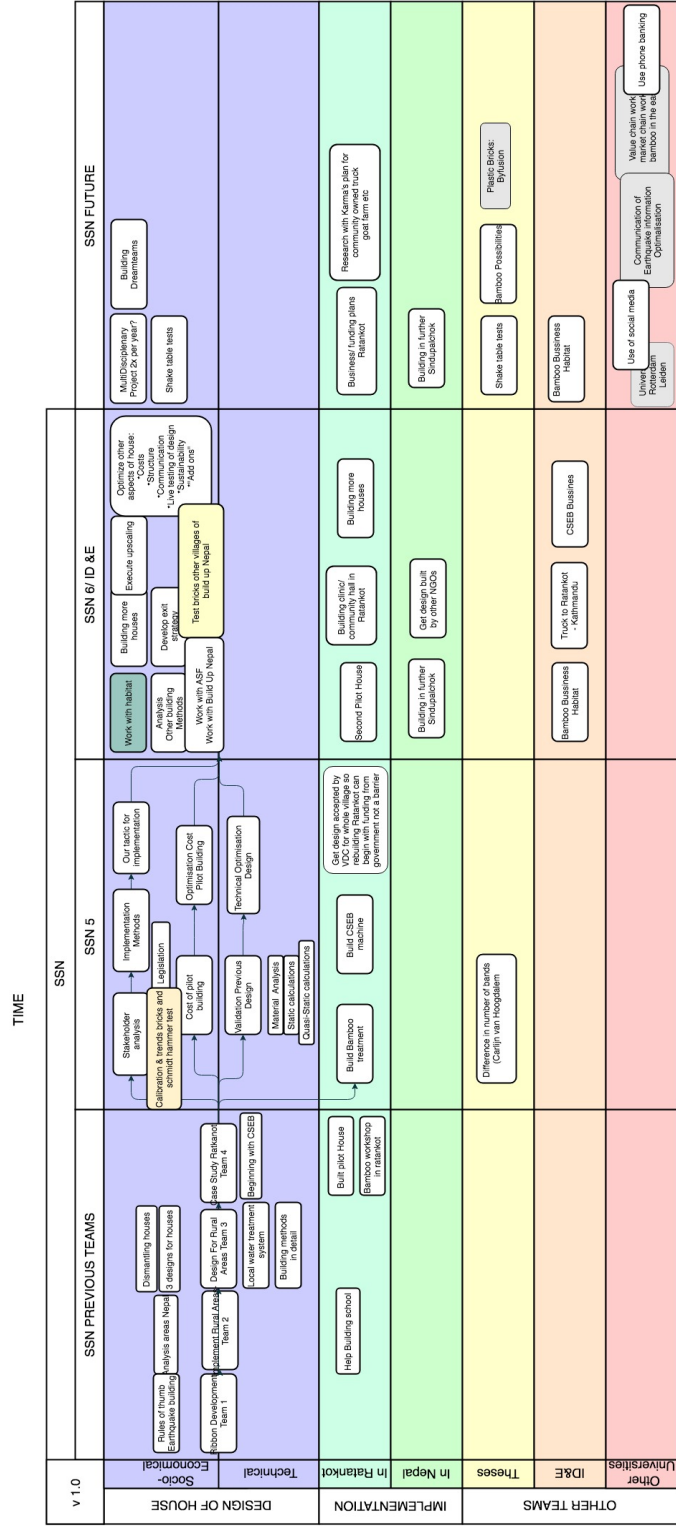

Scope/Subject

## BRAINSTORM OF FUTURE ROLE OF SSN WITH ALL SSN TEAMS

<p><b>Onsite ttesting of CSEB</b> 2/5 tonne hydraulic test cube of 8x8</p>	<p><b>Shaketable tests and good videos of it.</b> In: India Italy</p>	<p><b>Mensen Helpen</b></p>	<p>"Ik denk dat als het nu lukt om dat huis te valideren en zo tot een echt goed ontwerp te komen wat we keer op keer kunnen verbeteren tot een volwaardig huis een prachtig doel is. Ik denk dat zo'n huis niet zomaar af is. Het eerste doel was natuurlijk om <b>het huis aardbevingsbestendig en betaalbaar te maken</b>. Vervolgens zou je kunnen kijken om het <b>steeds beter of duurzamer te ontwerpen</b>. Bijvoorbeeld door een <b>echt watersysteem, of zonne-energie, bepaald kookstysteem, duurzame materialen, etc.</b></p> <p>Dus tot een volwaardig ontwerp te hebben van een huis komen dat men ook kan opschalen. Een huis dat in principe ook de 'normale' Nepalees kan bouwen en waarvoor niet alleen hulpgeld nodig is. Misschien wel een twee versies met beide een verschillende prijs. Bovendien is er misschien wel voor elk gebied een ander soort huis nodig (i.v.m. met andere omstandigheden, ondergronden etc.) maar dat is iets voor de verre toekomst. <b>Eerst 1 goed huis!</b></p> <p>Ben vooral nu erg benieuwd naar jullie validatie onderzoek, wie weet blijkt dat er toch een andere methode handiger of beter is i.v.m. wat dan ook...</p> <p>SSN binnen de TU: Verder zou het denk ik goed zijn als SSN een project is waar mensen op kunnen afstuderen en misschien ook hun PhD over kunnen doen. Ik zou nooit iets met bijvoorbeeld bachelor studenten doen. Ik zie het als een Master of dus Master+ project.</p> <p>Verder: Ik wil van SSN een stichting maken, ook om de continuïteit te waarborgen, met bestuur en al. Ik heb al met de KvK en notaris hierover contact gehad. Zo kunnen we makkelijker fondsen aanspreken en ook een rekeningnummer openen waar we een klein bedrag op kunnen zetten om verdere projecten te waarborgen."</p>
<p><b>Compressive strength</b> Early tests</p>	<p><b>Social Entrepreneurship</b></p>	<p><b>Knowledge about/research into disaster relief processes/ planning/ technical assistance</b></p>	
<p><b>10000 Houses built with Build up nepal as implementation partner</b></p>	<p><b>Building manual in Nepali</b></p>	<p><b>Water system DIY</b></p>	
<p><b>Gebruiksvriendelijke Software/website ontwikkelen voor lokaal gebruik (doorberekenen)</b></p>	<p><b>Videos on how to build earthquake resistant</b></p>	<p><b>Energy system DIY</b></p>	
<p><b>25 (?) Students a year working on the project</b></p>	<p><b>SUSTAINABLE! Buildings: Recyclable LCA of the building Local Material Use Closed Loop designs in terms of material transport &amp; livelihood</b></p>	<p><b>Organisation comparable to the Motown Movement?</b></p>	
<p><b>Fulltime Representative in Nepal and in NL</b></p>	<p><b>Provide hard evidence about Earthquake resilient building</b></p>	<p><b>Previous Teams on the role of SSN: Learning by doing instead of reading</b></p>	
<p><b>SSN FESTIVAL!!! Artist coming together showing the use of bamboo, traditional building methods &amp; new building methods. People meeting each other, art (how to build beautifully into the culture). Raise money for earthquake resistant building. Spread knowledge.</b></p>	<p><b>"Elk huis dat gebouwd wordt door..... Is doorberekend door de TU"</b></p>	<p><b>Information exchange between teams through workshops</b></p>	
<p><b>Knowledge Center</b></p>	<p><b>"I don't believe in entrepreneurs themselves testing the bricks. If the community knows how to test the brick- need to empower the people to test. Absolutely crucial."</b></p>	<p><b>Beursvloer with little projects from every team</b></p>	
		<p><b>Wellknown project for students, Umbrella organisation that has research questions/ assignments available</b></p>	
		<p><b>Broader research : eg other countries. Pakistan, India, Bangladesh, Haiti Other studies: eg Social, Political, Economical</b></p>	

### FUTURE RESEARCH INTO EARTHQUAKE RESISTANT BUILDING

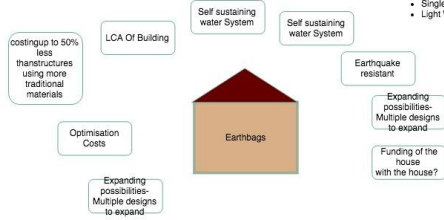
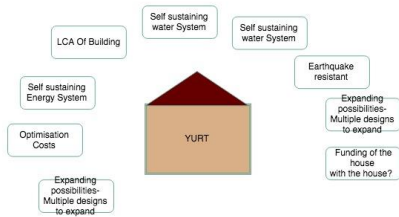
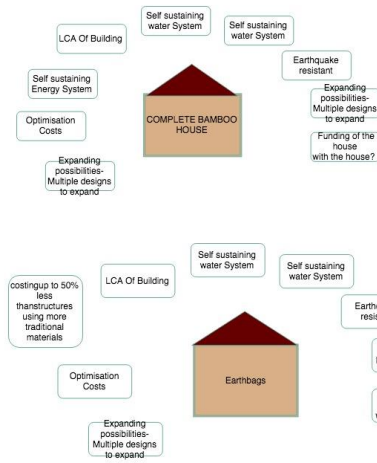
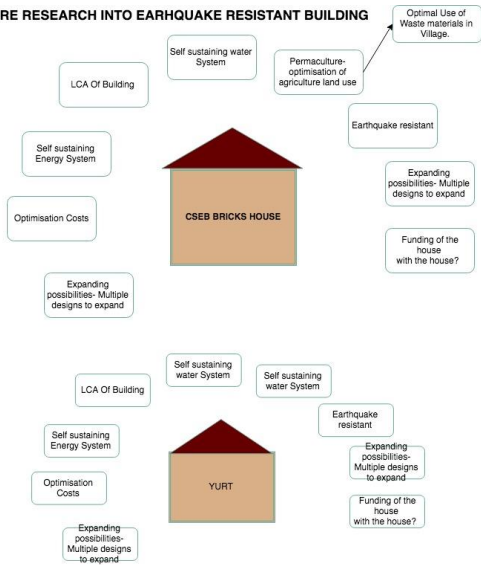

### LIST OF POSSIBLE BUILDING METHODS (Team 3)

- Low strength
- values (stone) masonry
- Low strength
- (brick) masonry
- Stone masonry in cement mortar
- Brick masonry in cement mortar
- Confined masonry
- Hollow concrete
- brick masonry
- Cement
- Concrete
- Concrete in-situ
- shear wall
- Timber
- construction
- Adobe
- Reinforced cement concrete frames
- Dhajji Deware
- Rammed Earth
- Steel
- Confined masonry
- Bamboo
- Earthbags
- Prefab-framed in-situ concrete
- Single Panel Walling System
- Light Weight Steel Profile building system

Text

As there are so many different types of building methods used in Nepal currently, and the building method that was used in Ratankot for the case study might not be optimal in every part of Nepal, this document was created. In it, project can be added that come across but do not necessarily fit into the scope of the group at the particular moment. By using this document, the research questions can be structured, a database of information regarding different building methods can be created and/or ways of comparing building methods (and implementation feasibility) can be explored.



## MONEY FLOWS RATANKOT

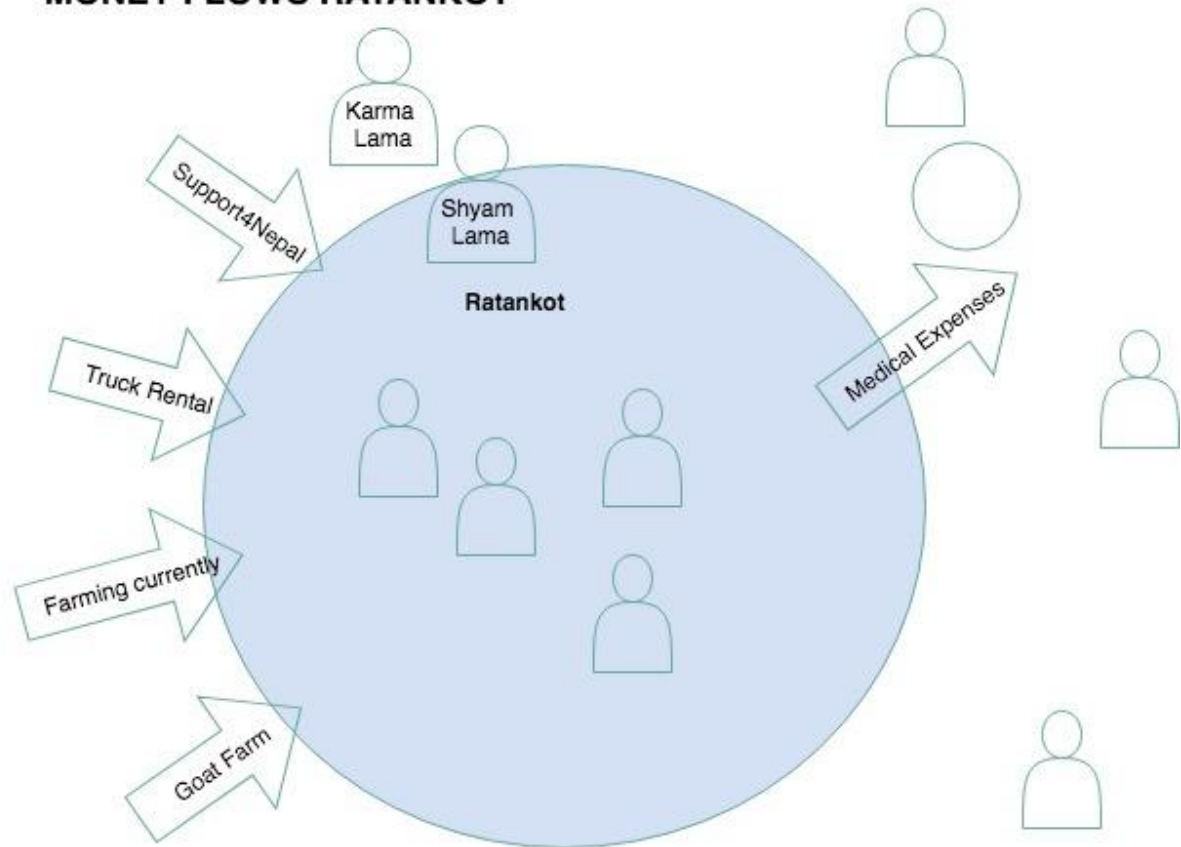

## Timeline disaster response

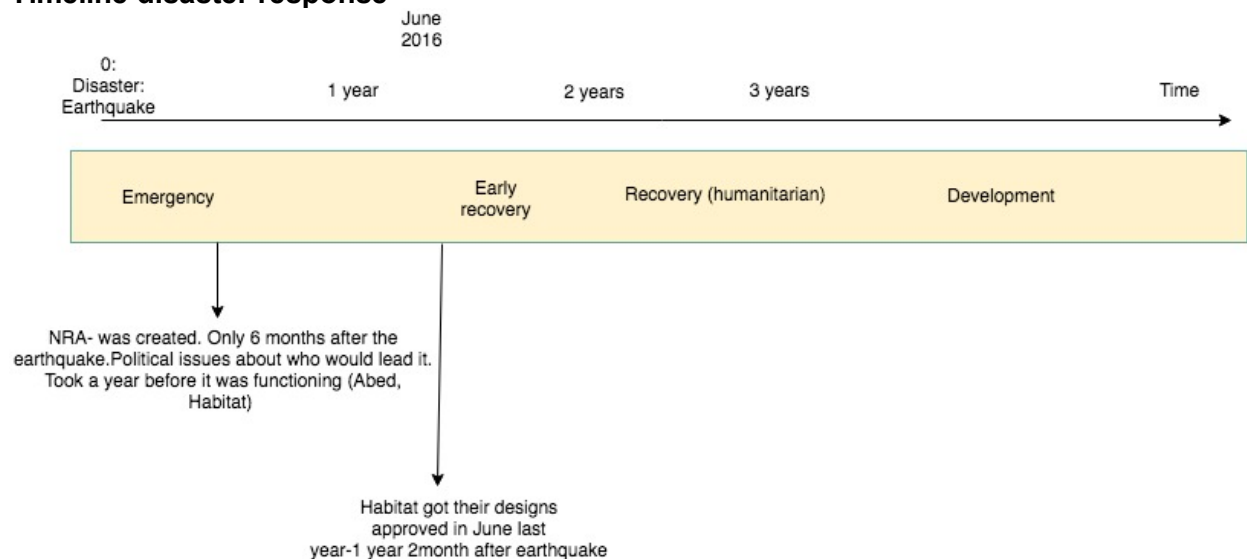

Exit strategy within two years is not possible- more within 5 or 10 Recovery strategy shouldnt take more than 2 years maybe 3 First year there no powercuts Microhydro in villages work better than electricity new

