

D4.

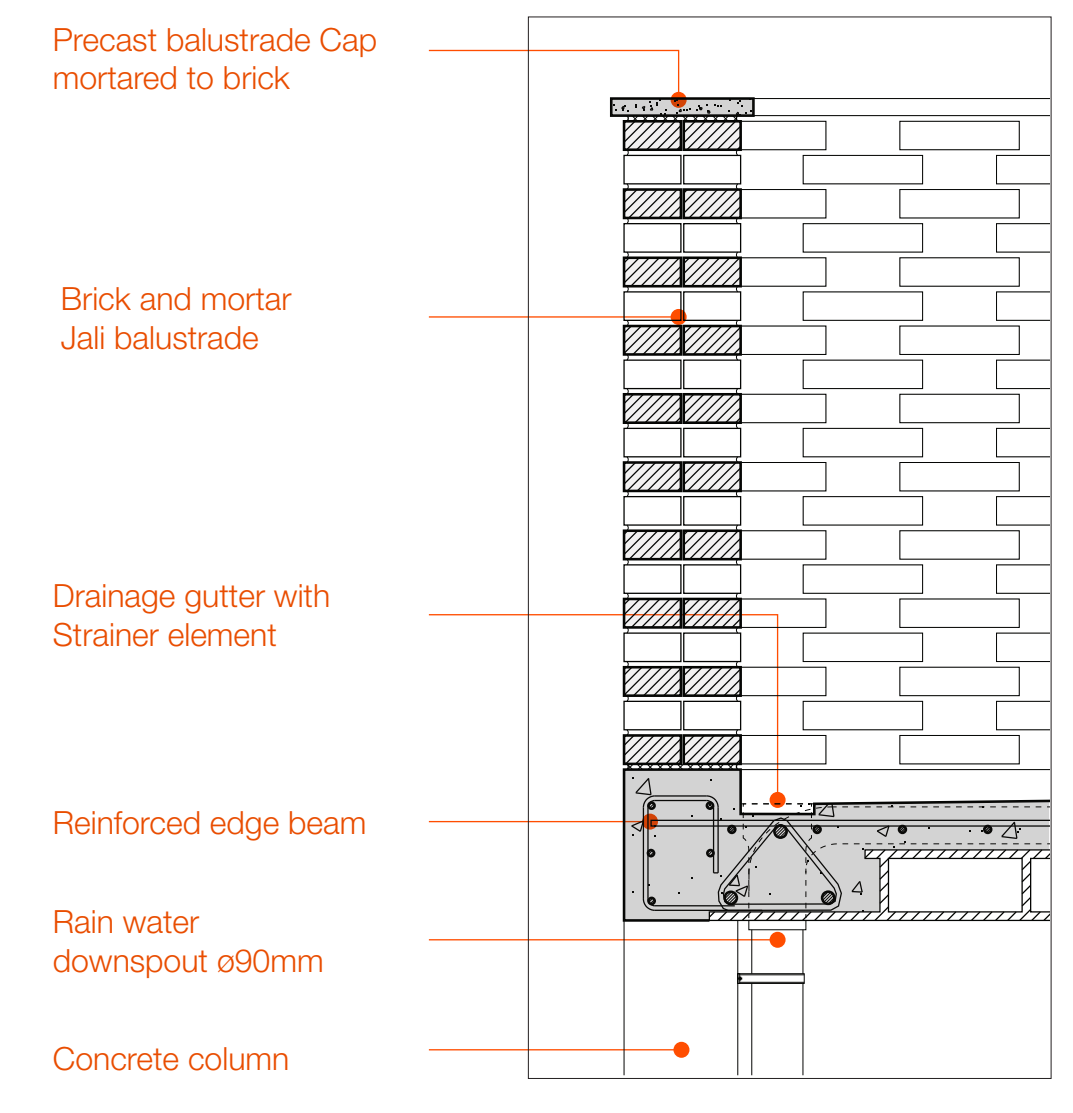

D3.

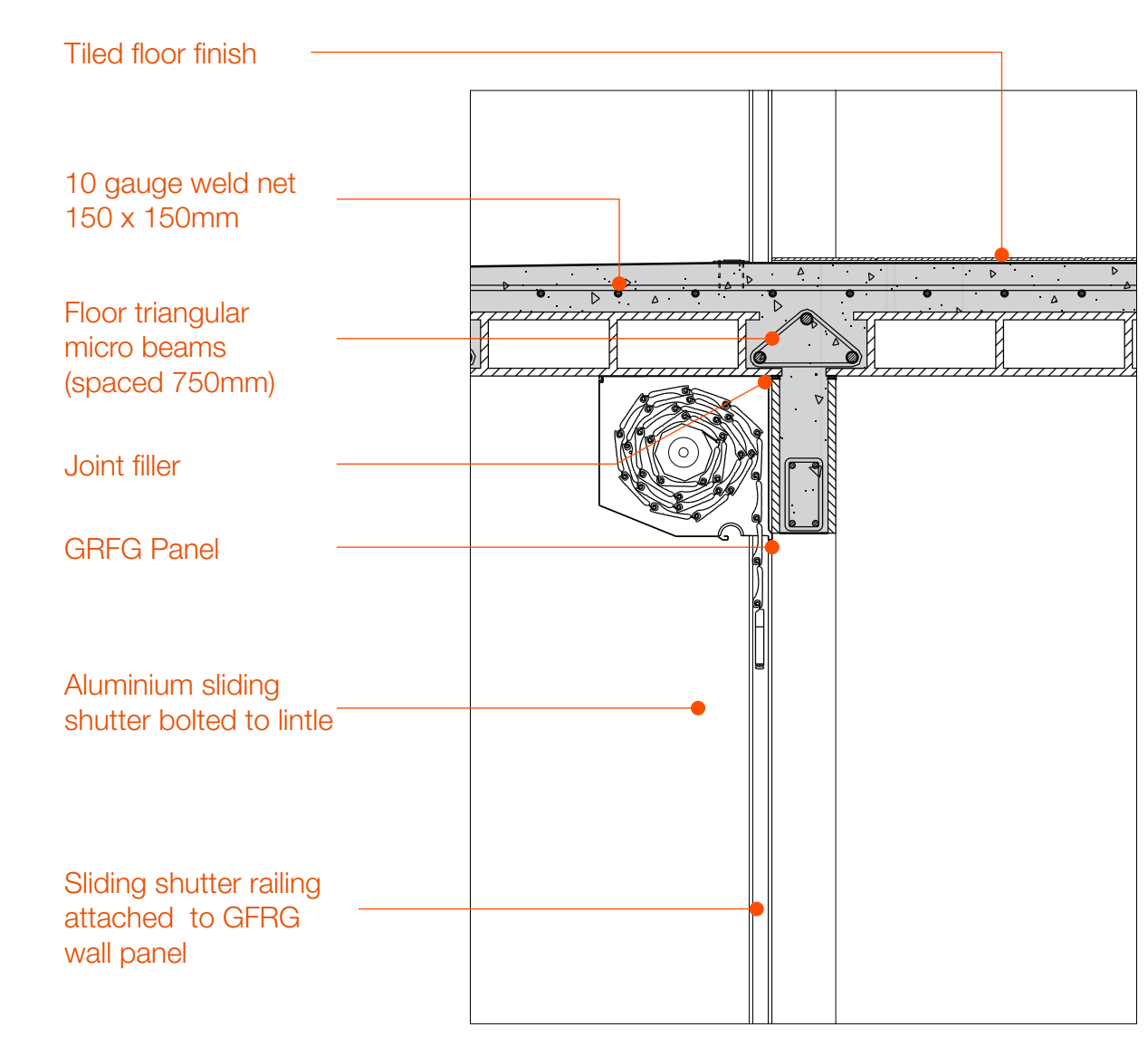

D2.

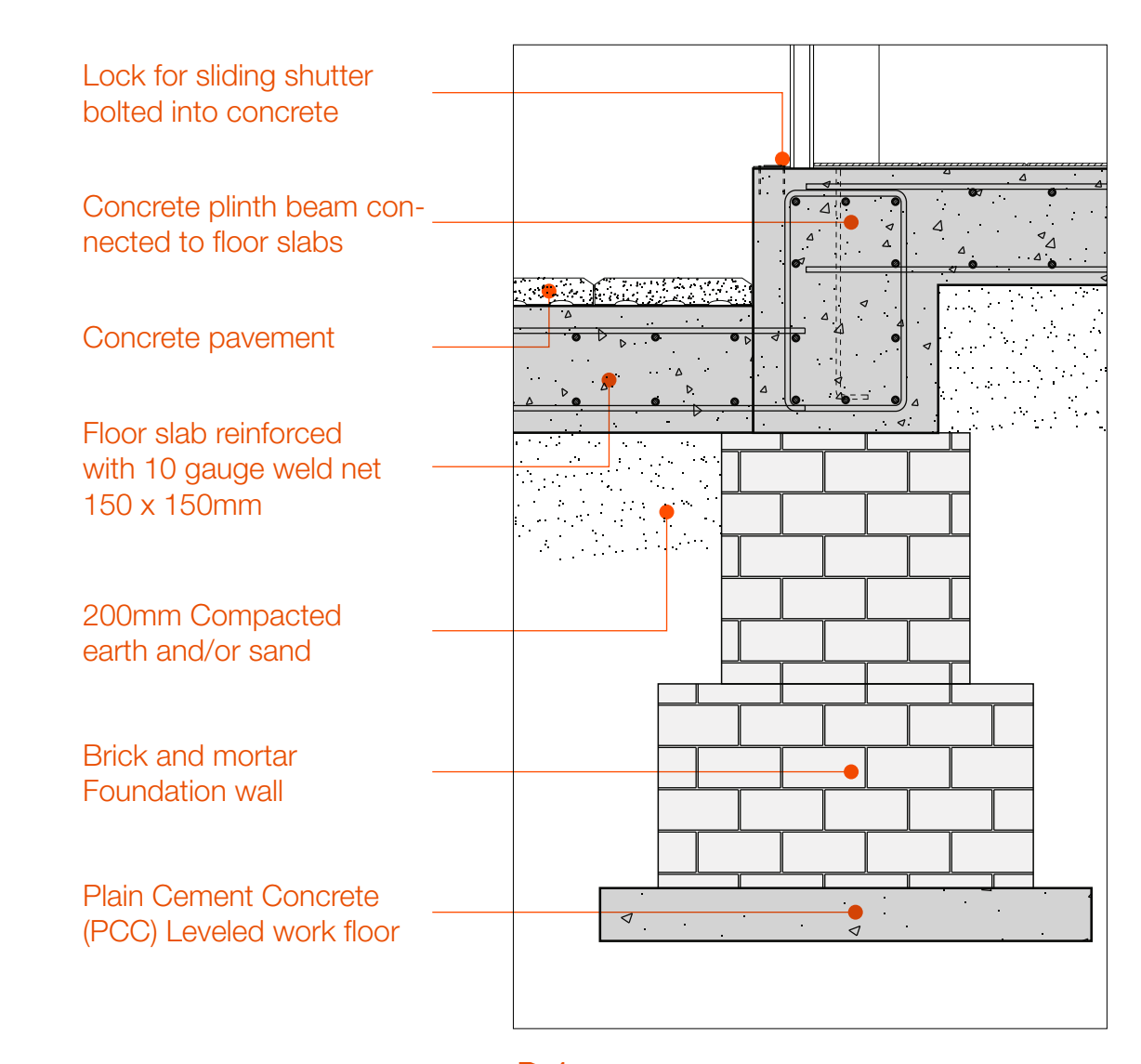

D1.

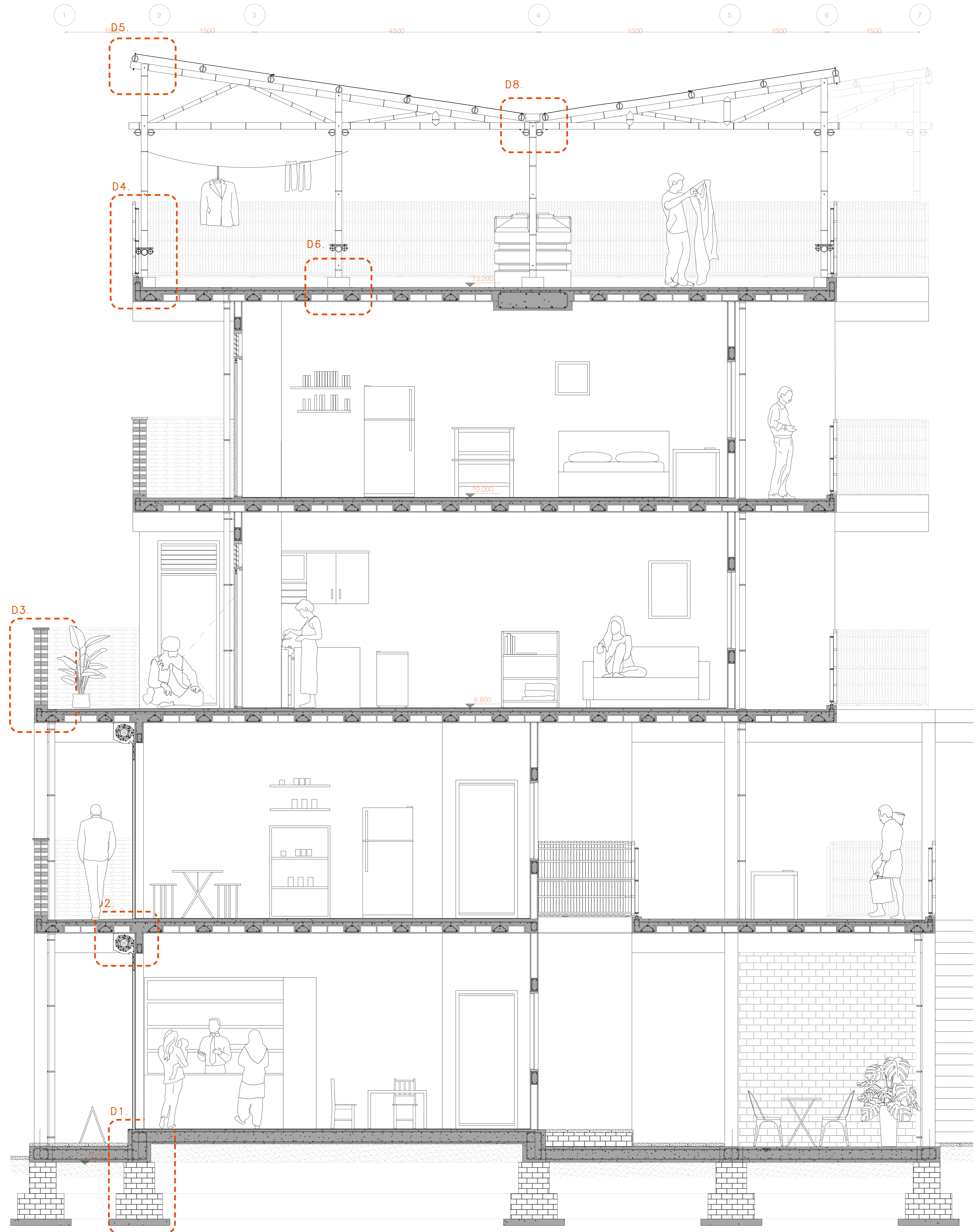

DETAIL SECTION 1:25

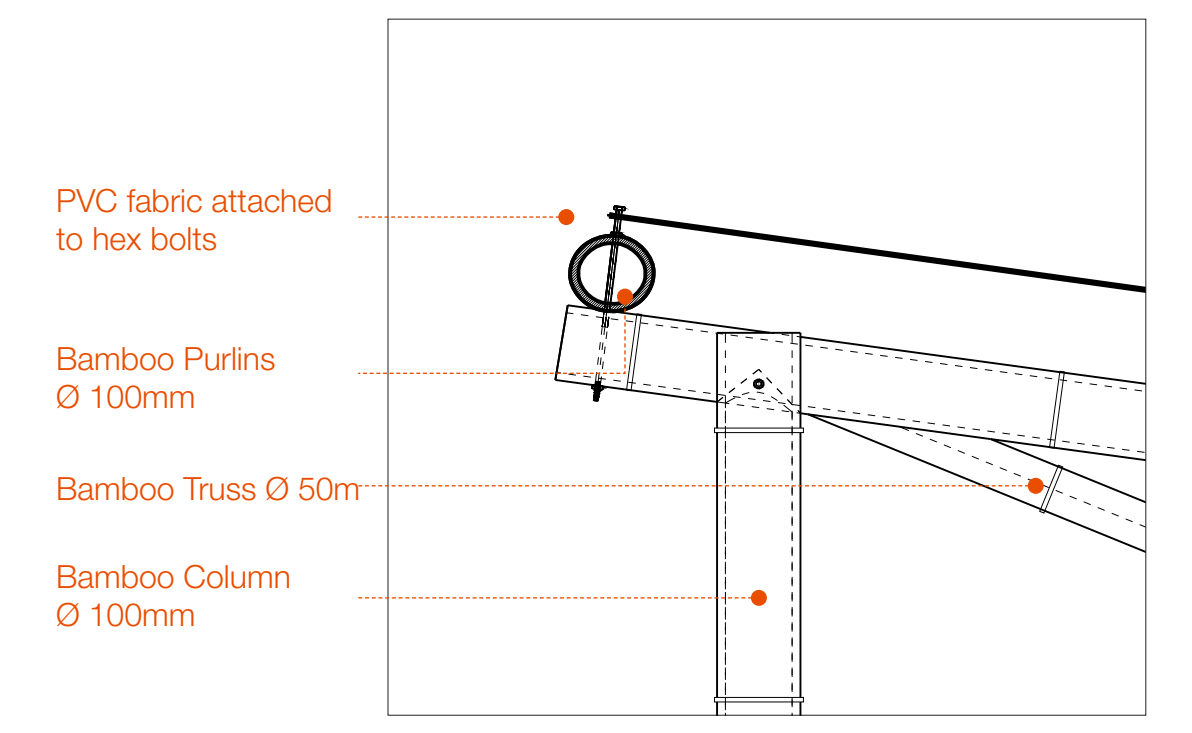

D5.

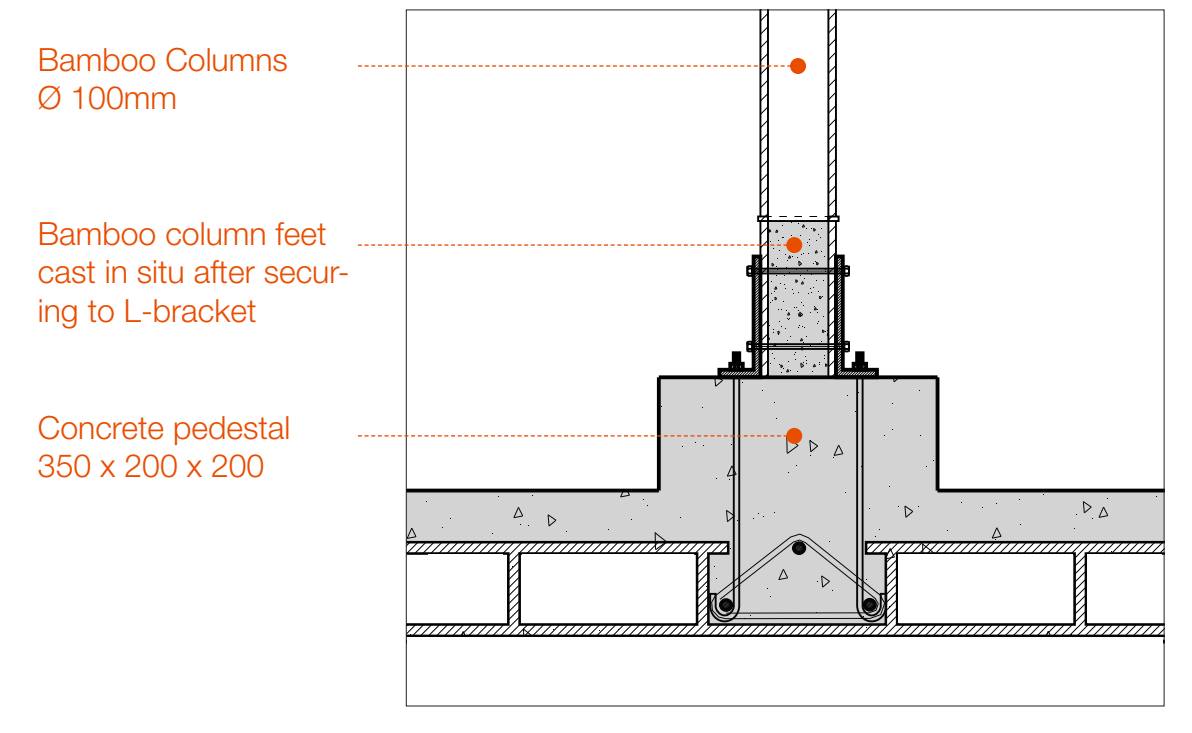

D6.

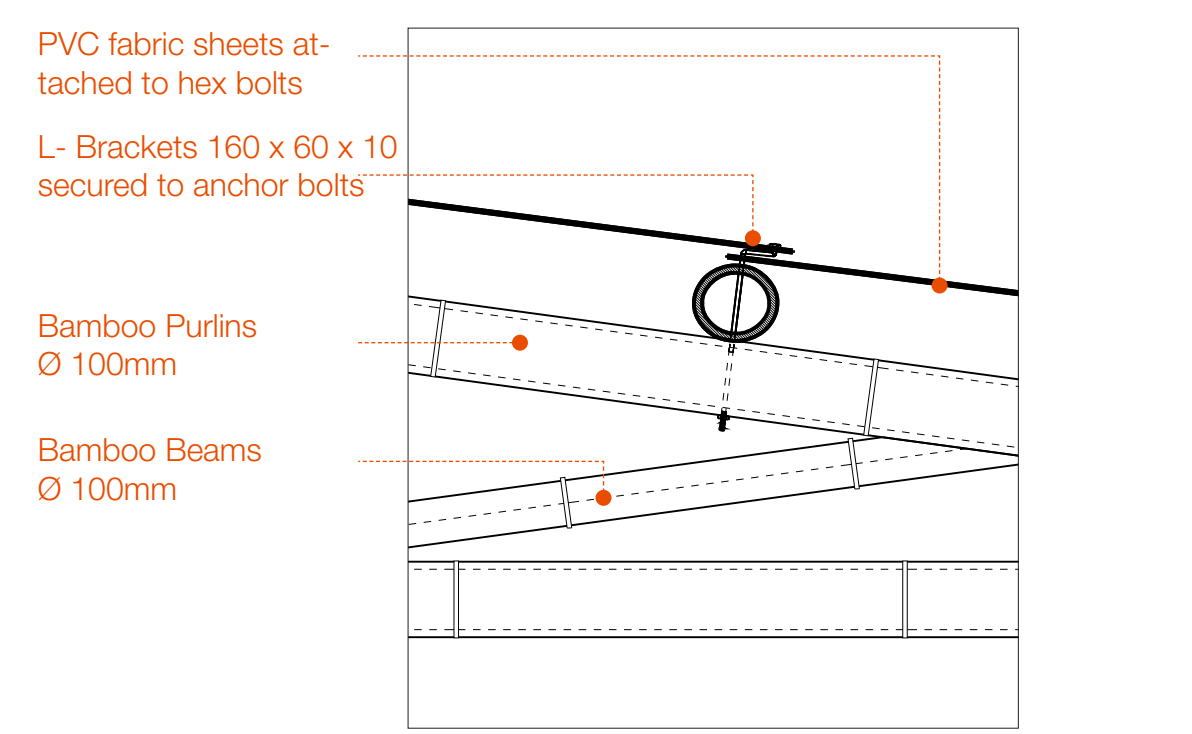

D7.

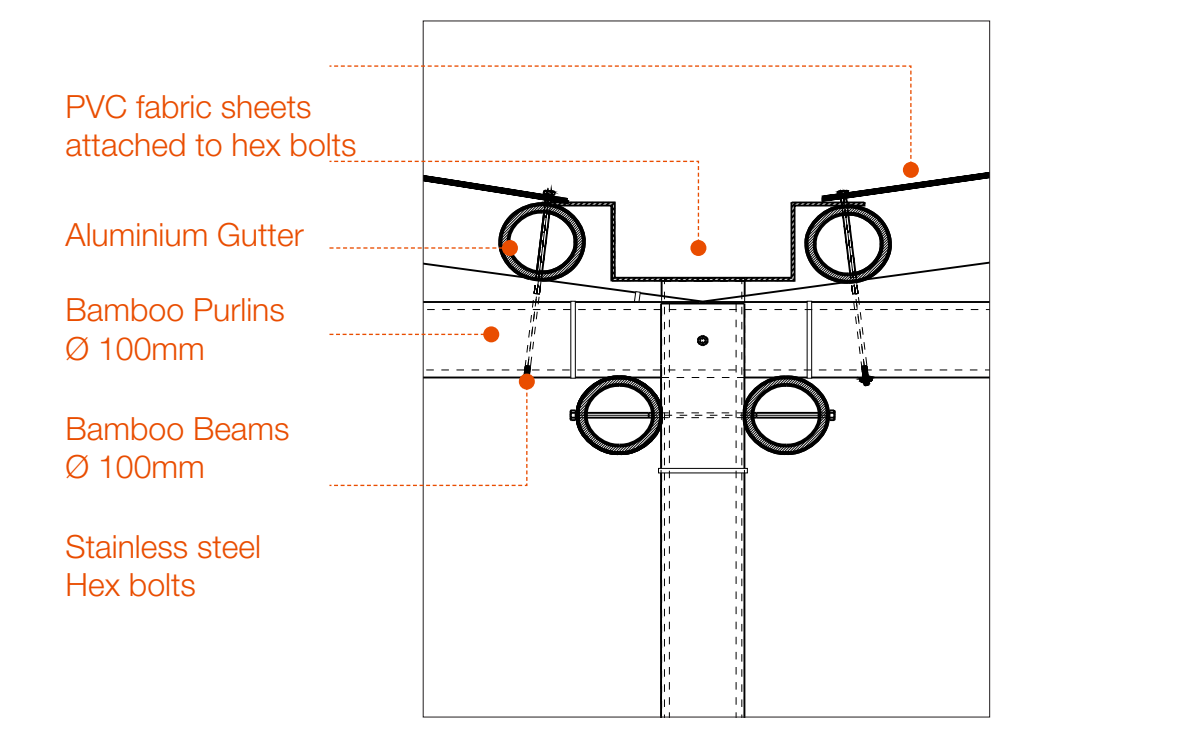

D8.

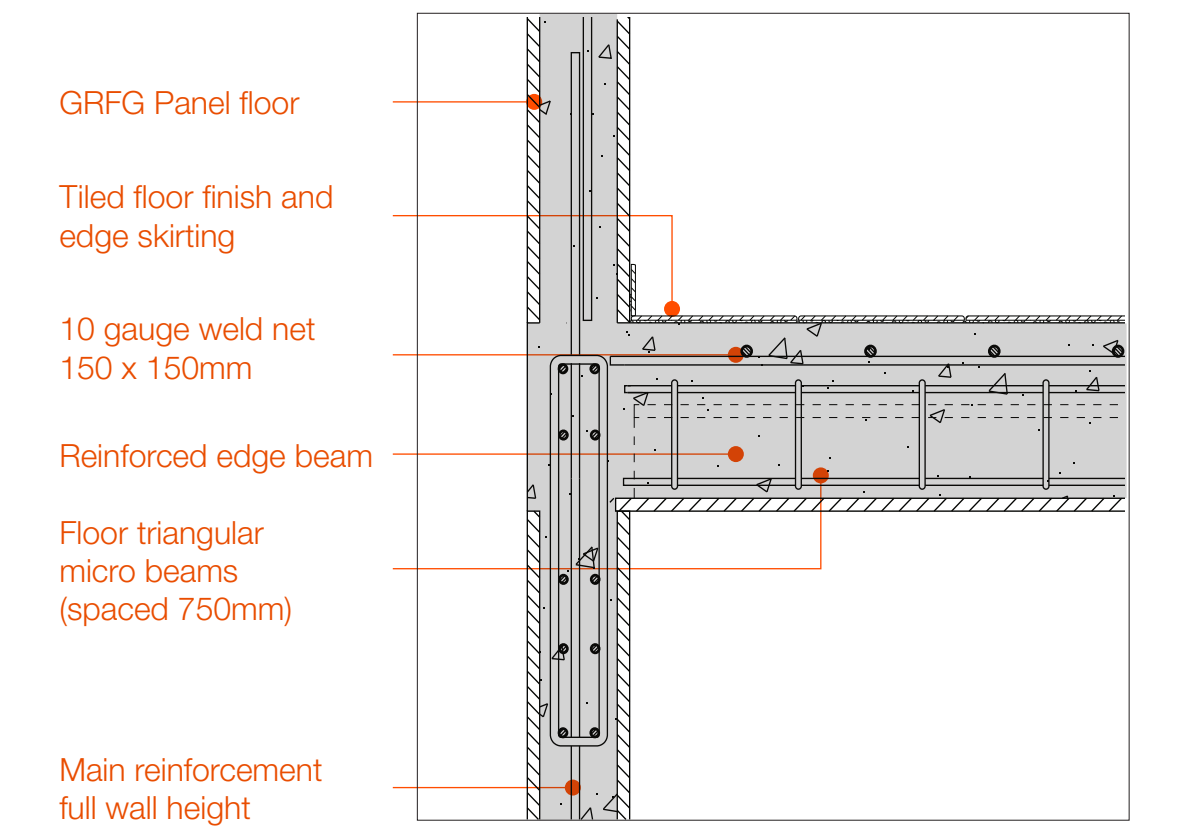

STRUCTURAL D9.

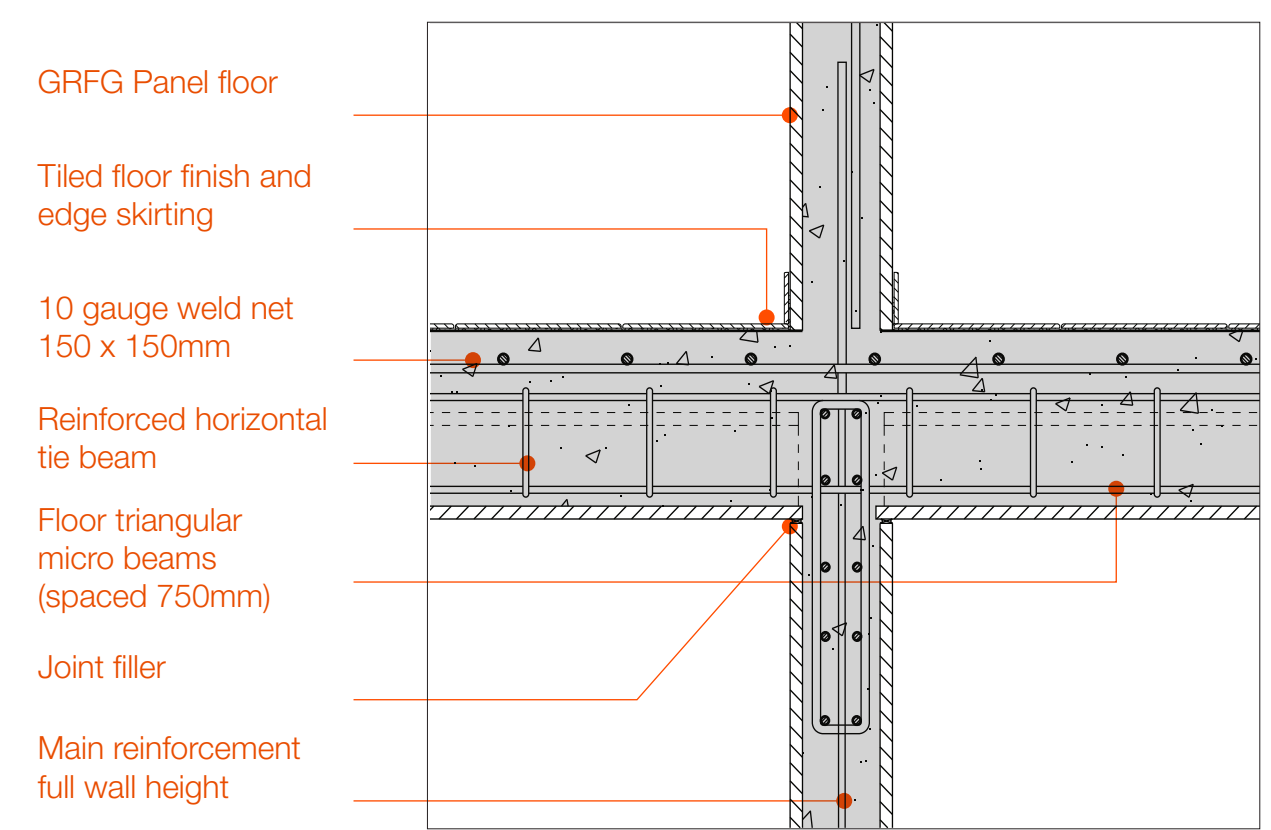

STRUCTURAL D10.



SCENARIO I: ACCIDENTAL DEVELOPMENT



GROUND FLOOR PLAN: MARKET STREET



FIRST FLOOR PLAN: COMMUNAL PLINTH

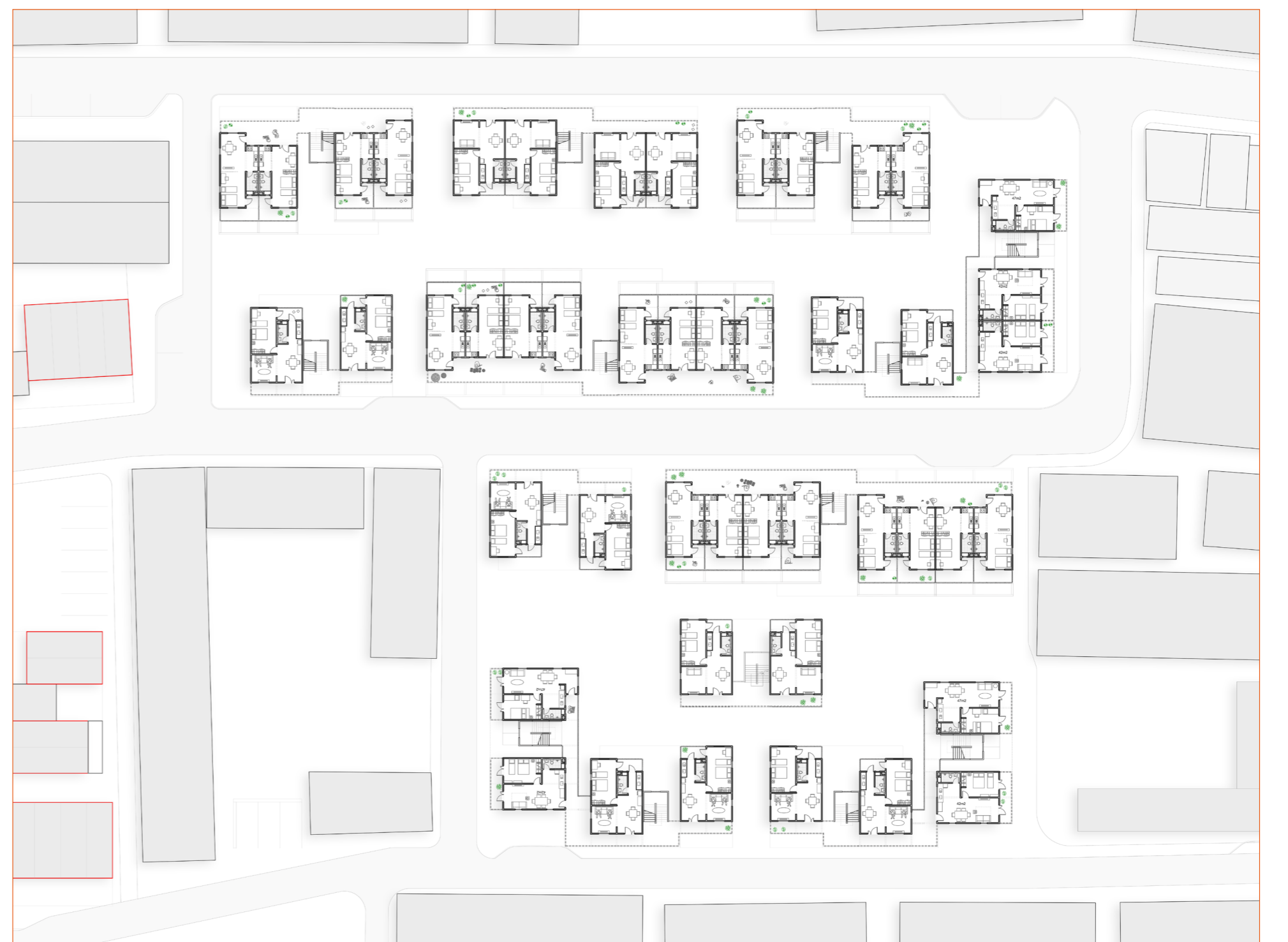

SECOND FLOOR PLAN: RESIDENTIAL FLOORS

SCENARIO II: MASTERPLAN DEVELOPMENT

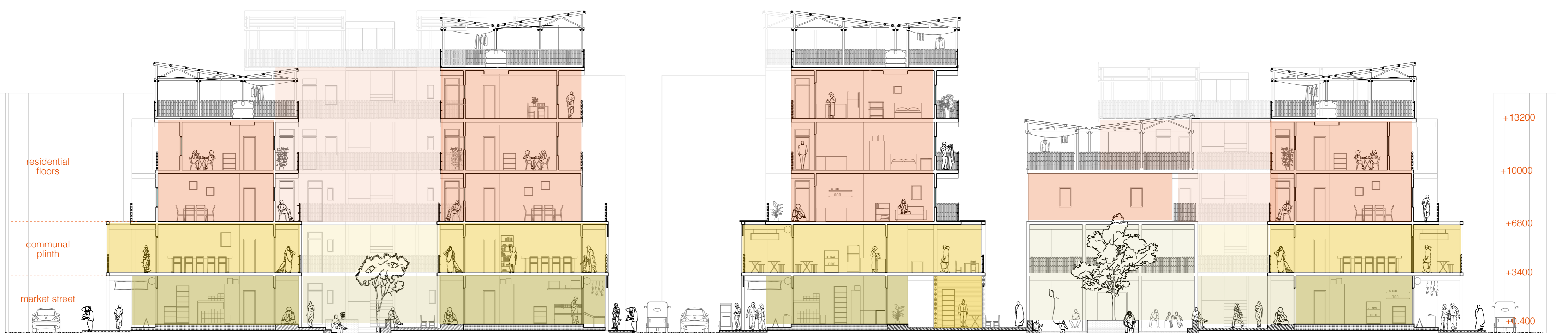
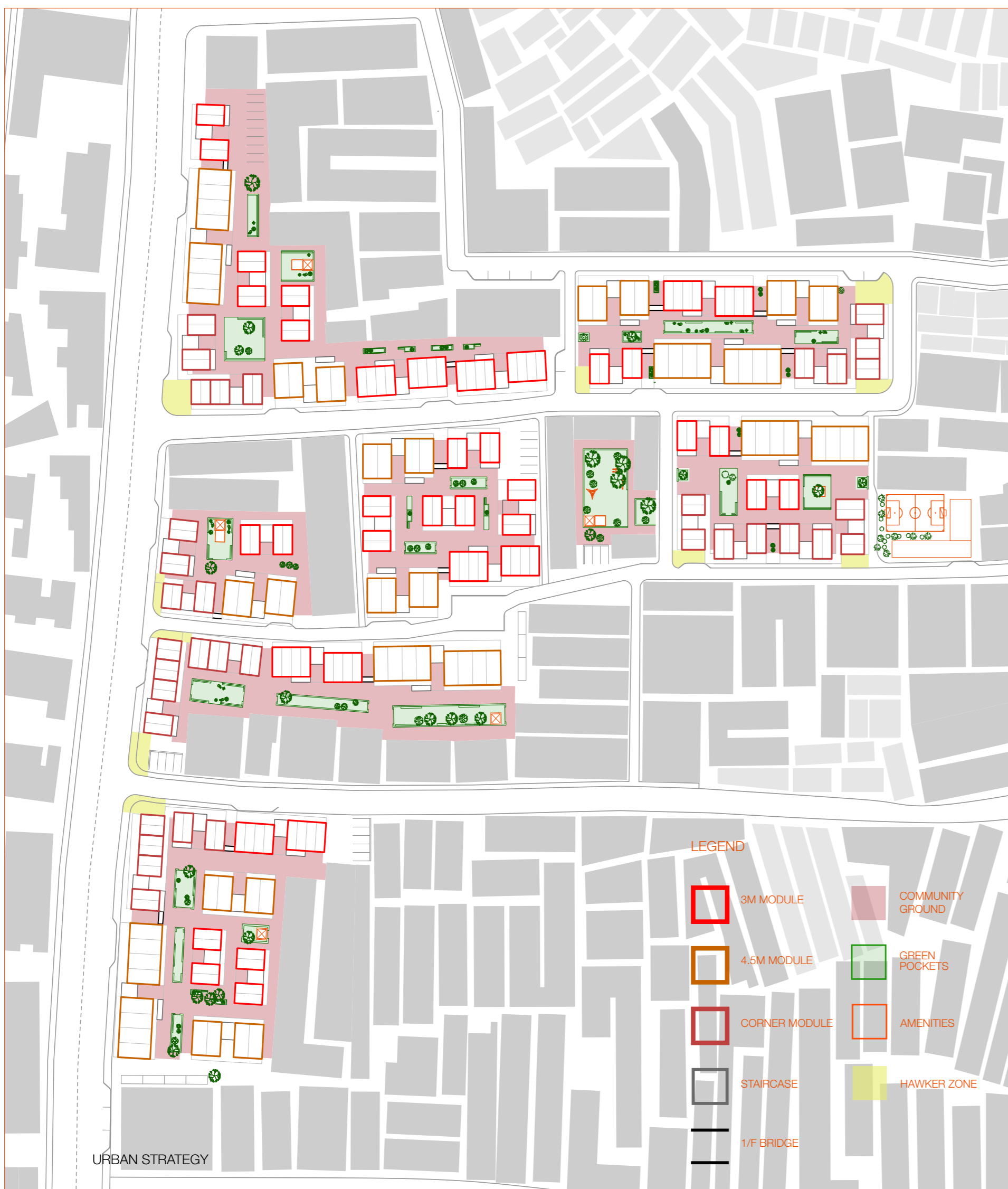



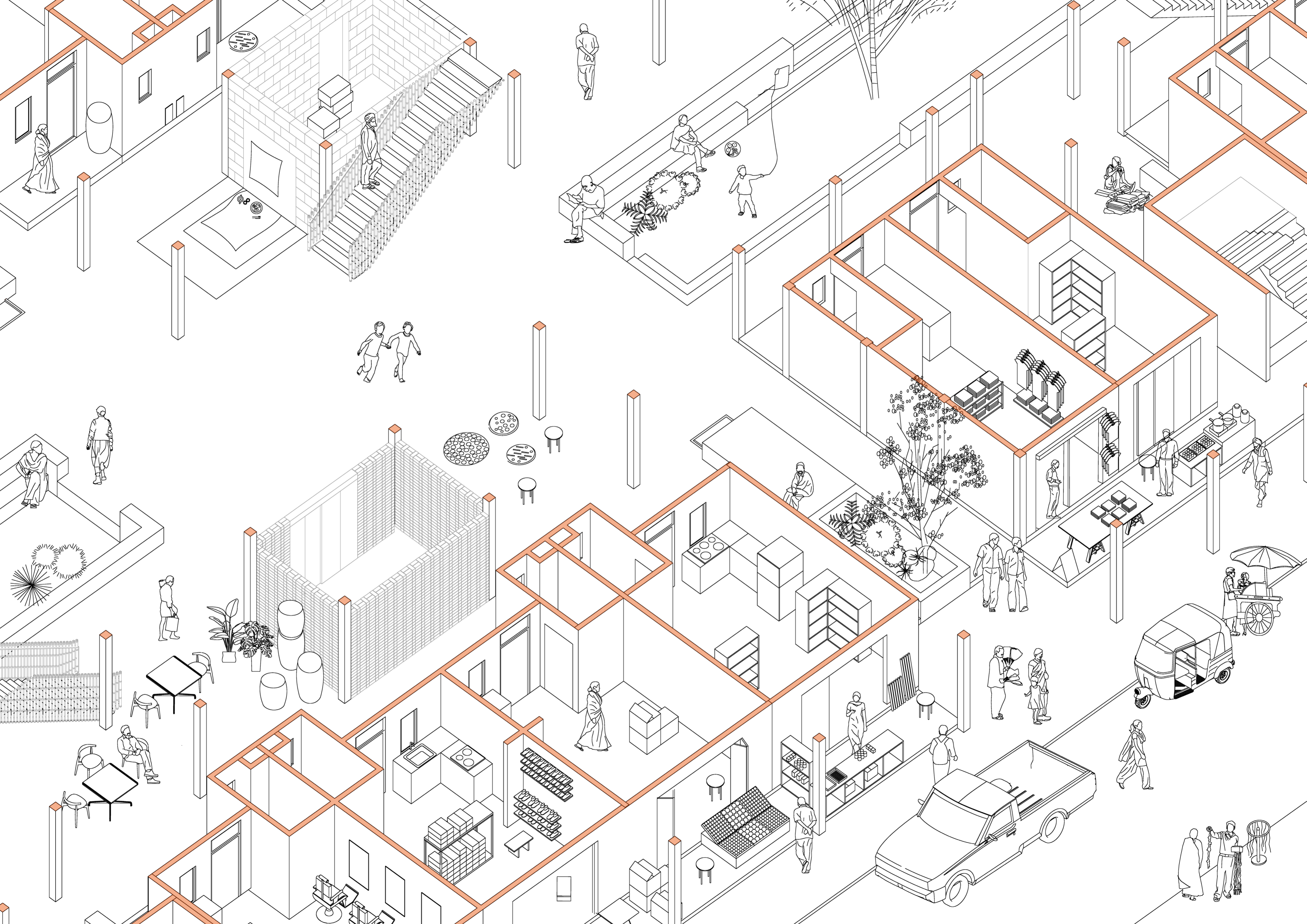



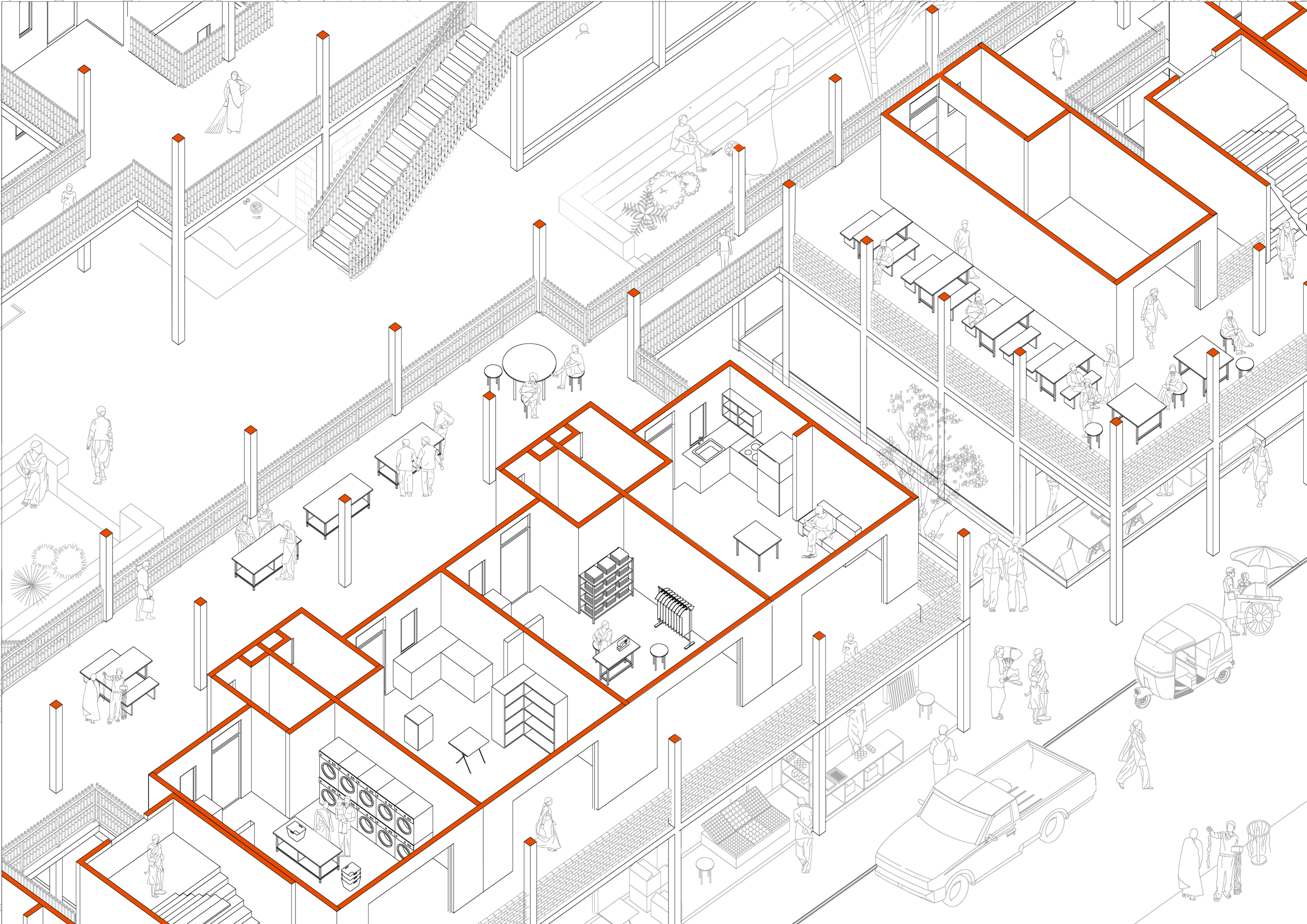





लिविंग सि  
मॉडर्न लाइफ

श्री पूरबजी  
जनरल स्टोर्स



















