

Interface on the skin

Designing through a user centered approach



Designing an interface on the skin

Through a user-centered design approach

Master Thesis
Delft, January 2020

Author

Thom Masselink
4460545
Design for Interaction

Supervisory team

Prof. dr. ir. Jansen, K.M.B.
Professor of Emerging Materials
Department Design Engineering
Delft University of technology

Dr. Ghodrat, S.
Assistant Professor
Department Design Engineering
Delft University of technology

External advisor

Dr. ir. Romero Herrera, N.A.
Assistant professor
Human centered design
Delft University of technology

Delft University of technology

Industrial design engineering
Landbergstraat 15
2628CE Delft
The Netherlands

Abstract

Since technological devices become smaller and our devices are more fused with our bodies, the logical next step is that technology will be placeable on our skin. In this thesis the design process towards a useful application of an interface on the skin is described. To get towards this design, several methods are used in the process. To shape the design challenge, a VIP inspired method is used, which provides a clear design goal and domain. For further developing the design, a user-centered approach is used, where the use of small prototypes helps improve the design. This resulted in a tattoo-like interface on the skin, which enables the user to have more unexpected interactions with others around him. This has been designed as a counter product towards the trend of people turning towards their devices in public situations. This tattoo offers a way of increasing real social interaction, and therefore decreases the social need of interaction through our smart devices. The design can be customly build up to fit the corresponding context, which makes it applicable in many social situations where people might have the need for more social interactions.

Preface

A trend involving technological devices is that they become smaller and more portable. We now carry our devices everywhere we go. Where we can still leave our phone on the table, a smart watch is already attached to your body and is more difficult to put away. A logical next step in the development of technical wearables is that they will be inside our bodies and on our skins.

It is therefore important that designers already try to figure out how these new devices might look like. My personal interest as an industrial designer to design innovative products, was something that resonated with the project brief of this assignment. To design a futuristic product as an interface on the skin, which does not yet exist, sounded like a problem I wanted to tackle.

In this thesis I will showcase how design can add to the development of these new, innovative devices that at one point will be integrated within everyone's daily life's.

Table of contents

| | | | | | |
|--------------------------------------------------|-----------|----------------------------------------------------------|------------|-----------------------------------------------------------|------------|
| 1 Exploring context and direction | 9 | 3.7 Technical analysis (Mechanochromism) | 61 | 6.4 Context: In a hostel | 114 |
| 1.1 Introduction exploring context and direction | 10 | 3.8 Electroluminescence | 62 | 6.5 Context: During the university introduction week | 115 |
| Societal analysis | 12 | 3.9 Technical analysis (Electroluminescence) | 65 | 6.6 Helping kids with social difficulties | 116 |
| 1.2 Factors that describe the domain | 14 | 3.10 Tactile augmented reality | 66 | 6.7 Helping elderly with arthrose | 117 |
| 1.3 The 11 clusters | 14 | 3.11 Technical analysis (Tactile AR) | 67 | 6.8 Layer build up | 118 |
| 1.4 Creating a future context and vision | 17 | 3.12 Shape memory materials | 68 | 6.9 Introduction to the prototype | 120 |
| 1.5 Narrowing the domain | 19 | 3.13 Technical analysis (SMM) | 70 | 6.10 Electronical build up | 121 |
| 1.6 The effects of technological stimuli | 22 | 3.14 Production of an interface on the skin | 72 | 6.11 Flow chart | 124 |
| 1.7 Design of desired interaction | 25 | 3.15 Working in the chemical lab | 74 | 6.12 Building the mesh | 125 |
| 1.8 Defining interaction qualities | 29 | 3.16 Conclusion exploring context and direction | 76 | 6.13 Making the prototype | 126 |
| 1.9 Conclusion societal analysis | 30 | 4 Exploring solution space | 78 | 6.14 Creating the visuals | 130 |
| 2 Personal analysis | 32 | 4.0 Introduction exploring solution space | 79 | 6.15 Conclusion Focus | 131 |
| 2.1 Introduction personal analysis | 33 | 4.1 Generating ideas | 80 | 6.16 Reflection on user adoption and persuasive design | 132 |
| 2.2 User Adaptation | 34 | 4.2 Clustering the ideas | 82 | 7 Conclusion | 134 |
| 2.3 Functional needs | 36 | 4.3 How do we use our time on the phone? | 84 | 7.1 Conclusion | 135 |
| 2.4 Cognitive attitude | 37 | 4.4 Target group | 85 | 7.2 Limitations | 136 |
| 2.5 Social aspects | 38 | 4.5 Exploration of awareness of relationship | 86 | 7.3 Recommendations for further research and verification | 137 |
| 2.6 Physical aspects | 38 | 4.6 Connecting to others through unexpected interactions | 90 | 7.4 Reflection | 138 |
| 2.7 Demographic characteristics | 40 | 4.7 Conclusion exploring solution space | 92 | 7.5 References | 139 |
| 2.8 Technological experience | 40 | 5 Defining solution | 94 | | |
| 2.9 Summary 6 factors for user adaptation | 41 | 5.0 Introduction defining solution | 95 | | |
| 2.10 Persuasive design | 42 | 5.1 Explorative user test | 96 | | |
| 2.11 Conclusion personal analysis | 47 | 5.2 The variables | 99 | | |
| 3 Technical analysis | 48 | 5.3 Contextual user test | 103 | | |
| 3.1 Introduction Technical analysis | 49 | 5.4 Conclusion defining solution | 105 | | |
| 3.2 Capacitive sensing | 52 | 6 Final concept | 106 | | |
| 3.3 Resistive sensing | 54 | 6.0 Introduction final concept | 107 | | |
| 3.4 Thermochromism | 58 | 6.1 Ealy adopters | 108 | | |
| 3.5 Technical analysis (thermochromism) | 59 | 6.2 Context: At a party (1) | 110 | | |
| 3.6 Mechanochromism | 60 | 6.3 Context: At a party (2) | 112 | | |

Project brief

Context

Electronic devices are more and more involved in our daily lives and routines. It seems that devices get fused with our bodies more over time. Where in the past devices stayed in one place (computer at work, tv in the living room), we now carry our phone and laptop everywhere we go. Where the laptop and phone could still be put away when we don't want to use them, the smartwatch is already always in our sight. Technology is becoming part of us and new devices are becoming more present in our daily rituals. It is likely to assume that technology will become even more connected to us, which involves using bodily gestures to control devices, and using sensors and actuators to express our current states.

In current smart devices and wearables, the input and output is mostly limited to a (small) screen. Yet, when sensors and actuators could be more integrated in our daily products or with our body, the user will have more possibilities of controlling devices, monitoring the body or expressing himself. With technology becoming smaller and smaller, these possibilities become more realistic, resulting in this study which explores the possibilities of interfaces on the skin.

Possibilities

Interfaces on the skin provide new ways of interaction between users and interface. These new ways of interaction can result in devices that can help the user in situations or extend the users experience, for which conventional interfaces are insufficient or are not preferred.

Scope of the research

The main focus of this assignment will be on searching for and development of a useful application of a thin, flexible/stretchable interface that can be placed on the skin.

A specific area of implementation has yet to be found, which will be part of the design process. When a useful implementation area of interfaces is found, a human-centered design approach will be used in a further search for, and development of this idea. Interactions, and functional and aesthetic properties are important and will be kept in mind during the research, exploring solution and defining solution phases. Because of limited time, the

research will focus mainly on finding and designing a new application for an interface, and will not focus on improvement of the technical workings of thin sensors/actuators.

Assignment

Designing an interface using thin and flexible/stretchable sensors and actuators, for future human computer interaction located on the body. The device should have a useful purpose and help the user in performing an interaction that improves or enhances the users experience or execution of a certain activity.

Approach

During this graduation project, different methods are used to come to a final design. For narrowing the design goal as stated in the design brief, a Vision in Product-design (from here: VIP) (Hekkert, 2011) inspired method was used. From here, an initial product idea is further conceptualized using an user-centered design approach.

VIP

The VIP approach is a method that is suited for (re) design of both existing as new products. In this case a new product will be designed, and the VIP approach can be seen as a guiding tool to come to an idea that also links to today's world. The VIP method helps in analyzing today's context, and see the bigger picture of it. The designer can then determine how their product should take its place within that context and towards the user.

User-centered design

Throughout the design process, the user will be included in the process. During the exploring solution space the user will be included and can help through broadening the view and give opinions on possible ideas. During the defining solution phase, early prototypes will be tested with the user to gain their opinion, and find out which interactions in the product are preferred and which are not.

These two techniques are divided over three design phases:

Exploring context and direction

In this phase, the VIP approach is used to narrow the design brief by converging the context, and determining the desired interaction for the product.

Exploring solution space

Here, the user will be involved to generate and define possible product ideas. This will be done through several creative sessions.

Defining solution

An initial idea will be tested with the user through several early prototypes and their opinions can help to detail the concept.

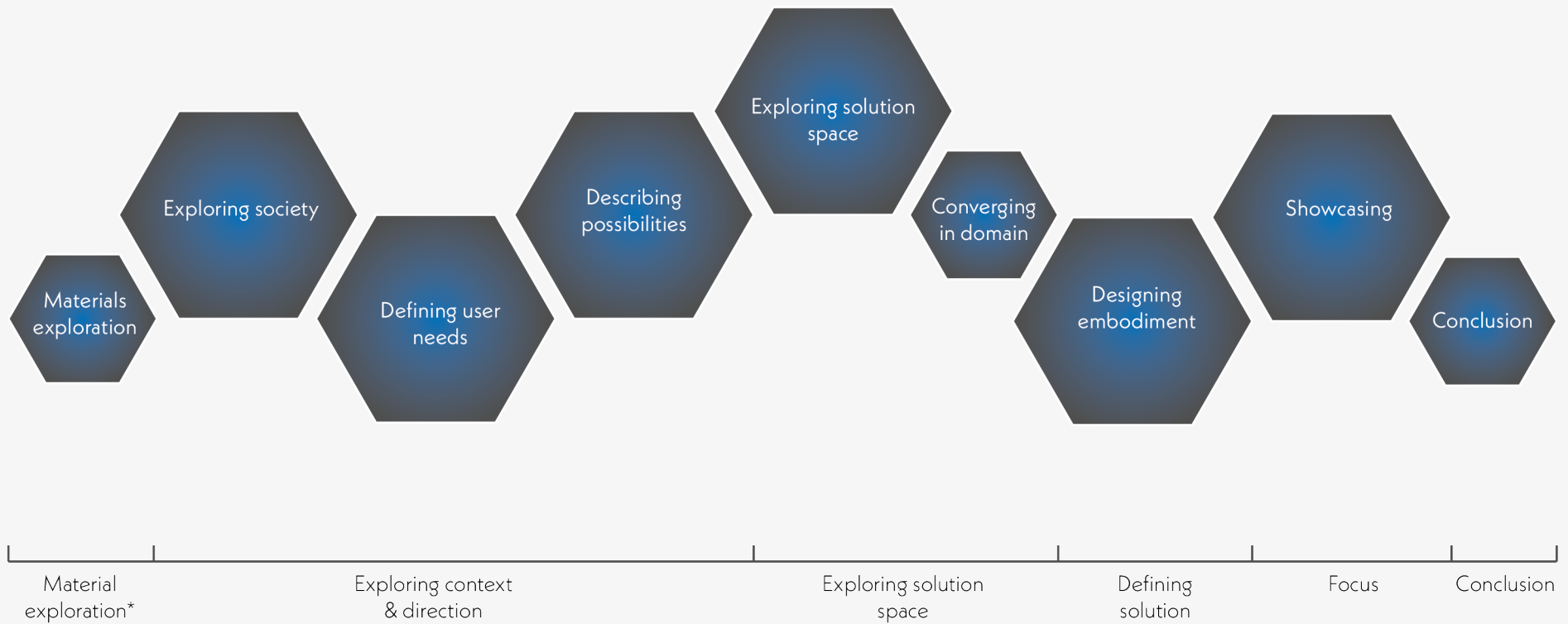

* The material exploration is a separate research report. An overview of this report can be found in appendix A

**Phase:
Exploring
context & direction**



1.1 Introduction: Exploring context and direction

The main purpose of the exploring context and direction phase is creating a foundation to build on during the following parts of the graduation project. This includes inspiration and guidelines for the exploring solution space, and technical knowledge and know-how for further development. The exploring context and direction phase can be roughly split into three different components (figure 1.1)

1.1.1 Analyzing societal aspects

Here, a vision is created and the domain is converged. Since the assignment is very open, a convergence of the domain is necessary. What should the interface on the skin achieve? What are important factors to achieve that? And how should it be perceived? In order to answer these questions, the current context will be analyzed, which results in a vision and a desired interaction.

1.1.2 Analyzing personal aspects

This chapter is creating the bridge between the desired vision, and the interface on the skin. It will not so much describe the physical aspects of the product, as it will provide guidelines on user factors that are important to reach the desired goal.

1.1.3 Analyzing technical aspects

This chapter contains the technical possibilities which are defined and help to map out possibilities and limitations for this project. This can function as inspiration for the exploring solution space, and it provides more knowledge on what is feasible and what is not, which is helpful in the phases of defining solution and during prototype building.

These three sub-chapters all provide information on different levels, which are valuable in different ways. All the information provided in this chapter functions as a foundation for the next phases and define the direction on the technical, social and societal level.

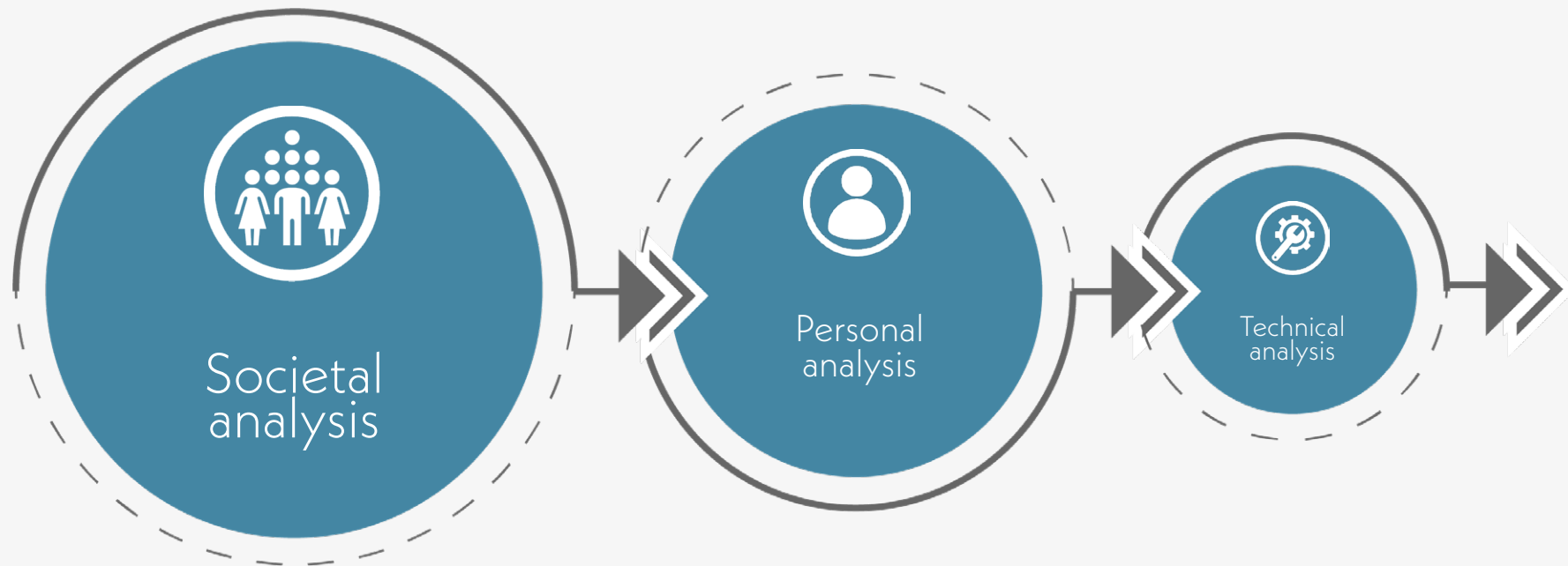

Figure 1.1: The different steps in the exploring context and direction phase.

1

**Societal
analysis**

To design a futuristic device, first a good understanding is required on how this future possibly could look like. Analyzing how consumer technology itself, but also the interaction between people and their technology developed over time, can help to get an understanding of which direction people and consumer technology are probably heading. A tool that helps in the analysis process is the VIP method:

Define interaction qualities

Which words characterize this future interaction? Finding a suitable analogy helps in describing these interaction qualities.

Describe the current context

Collecting different factors that help to describe what is currently happening in the chosen context.

Design of the desired interaction

Determine how the interaction between user and product should be, based on the vision and product function.

Clustering of context factors

Clustering can be used in order to decrease the amount of factors, by putting together the factors that describe the same phenomenon.

Converge the design direction

The clusters will be used as well to narrow down the design domain, to give more direction to the idea generation phase.

Creating a future context

Between all clusters, a pattern can be found, which describes what is happening in the world. How you respond to this development, will be your vision.

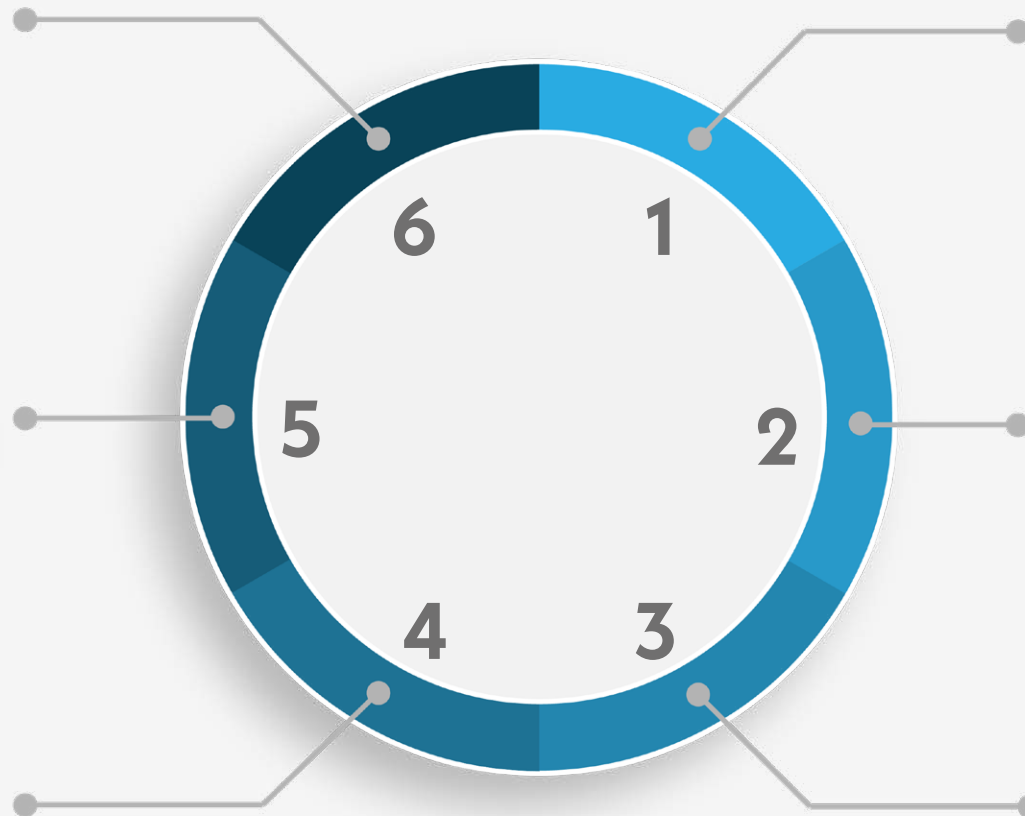



1.2 Factors that describe the domain

To come to a vision for the future interaction between user and the interface on the skin, the broad domain of interactions and technology is explored and expressed using factors. These factors can be classified as developments, trends, states, or principles (Hekkert, 2011) and help to describe the domain and how it is developing. These factors can be obtained through many ways, such as searching the news or through own observations. Everything that seems relevant to the domain can be listed. Different scientific areas are used to keep the range of results broad enough. How does technology behave within these different scientific areas, and how are people affected by that? The result is a little over 100 factors that all tell a lot about the domain of interactions and technology. All factors (appendix A) are clustered in coherent groups, in order to see the bigger picture of what is happening in this domain. From here a choice can be made: Do you like what you see or would you like to see it differently? The response that is given to this question can be interpreted as the design vision.

1.3 The 11 factor clusters

1.3.1 Technology is causing global environmental problems

With the advancement of technology comes the advancement of humanity. Less people die of diseases and more people have access to technology and the internet. The downside is that it is pressuring the environment. More natural resources are needed, there are more people that pollute, and the technological waste is difficult to process.

1.3.2 Technology is improving humanity

Technology has numerous benefits for people in general. It is easier and more efficient to provide people with their basic needs such as food and shelter, but it can also help people emotionally: for example elderly feeling less lonely. Technology can solve many big environmental- and demographic issues.

1.3.3 A human response to technology

Technology has many positive and negative influences on our lives, which are rapidly changing. Sometimes people long back for past times where this abundance of technology was not yet shaking up their lives: back to simpler times. This could for example be reached by periodic absence of technology, or by doing activities that involve a lot of real world interaction.

1.3.4 People polarize more in their opinions

It is easy to give an anonymous opinion on someone on-line, without any consequences. Because of this anonymity, people tend to give their opinion without giving it much thought beforehand. This results in on-line social judgment and people being more polarized in their opinions and ways of speaking.

1.3.5 The world is becoming smaller and people's lives are more connected

You can see any street in the world from your computer, and actually traveling to far away places has become more accessible. Although it might not always be convenient to visit relatives that live far away, it is still possible to see them and talk to them, with a click of a button. People are coming closer to you, which also can be negative. Problems of countries often become problems of other countries or continents as well.

1.3.6 Technology empowers people to be more independent

People are more in control of their own lives. The information on the internet allows for own opinion forming and self enrichment, and people have more control on which media they watch. It has also become easier to take care of yourself: people can create their own energy and devices enable them to be more mobile and in control of their own bodies.

1.3.7 There is more influence of others on your way of living and your thoughts.

Many people gain self esteem through on-line popularity. People's emotions are influenced by likes, and by what is seen on social media. Yet, what is seen is determined by algorithms and people working at technological companies. Not only do these companies have influence on their moods but also on politics, since these companies are amongst the biggest in the world and can influence and pressurize politicians.

1.3.8 Technology is constantly changing the shape of jobs and products.

The advancement of technology is constantly improving the efficiency of people and companies. This changes the way we do things and the form of our products. Think of the online store replacing the physical one. This saves shoppers a lot of time, but takes away the job of the salesman.

1.3.9 People are becoming less responsible and more dependent.

People have become more dependent of on-line services, which we provide with all our private data. Technology is distracting people from their surroundings, causing dangerous situations in traffic or losing sight of their children.

1.3.10 People live more in the digital world than in the real world.

With the rise of the internet and social media, people live more in the digital world, which is at the expense of interactions in the real world. Social media is addictive, which makes it distract people from things they are doing in the real world. This results in for example quality time with the family, or less efficient working hours.

1.3.11 People are overwhelmed by the amount of stimuli they receive.

In general, people receive a lot more stimuli compared to some years ago. This is not only more exhaustive for people since the brain has to process all these impressions, but it can also make people addicted to it. Many people find old movies too slow now, and people get bored easily and distracted quickly when they have to do tasks that involve very few stimuli. They start to search for something that provides more stimuli, which often means time that is wasted.



1.4 Creating a future context and vision

1.4.1 The context

Looking at the clusters, it became visible that there are a lot of contradictions between them. Technology has positive impact on our daily lives, but at the same time confronts us with difficult new problems that we should cope with, as individuals and as a society. Technology makes our lives easier and our jobs more efficient, but on the other hand more complicated. Technology can be used to benefit the environment, but the production of technological devices also harms it. People have to find a way to benefit from the positive effects, and deal with the negative ones.

A good example is the interconnected world that the internet has created. Nowadays it is very easy to connect and talk to anyone through the internet, and this provides people with numerous benefits. On the other side, the internet allows people to insult others anonymously, without any consequences or social judgment. People are able to benefit of the positive aspects of open internet, but not able to deal with the negative possibilities this provides: People do not think about the consequences of their words for the person who is at the receiving end.

Another example is people sharing their lives on social media. On one hand this is positive, since it connects people's lives through sharing events. By receiving likes from others, people's self-esteem can grow which could be beneficial for them in real life. A negative aspect is that this showing off on-line can cause others to become insecure. Only positive aspects of someones live are shown, which is causing unrealistic expectations for others.

Technology also has an influence on our way of interacting with products, and with the people around us. Products are becoming smarter, therefore there are more ways of interacting with our products. Our products are on their turn better in understanding what we expect from them. Algorithms cannot only understand what we say, but also learn from it, and therefore improve itself.

Our ways of interacting with each other also has changed. We are living more in the digital world than we used to do, and therefore interact less with our physical surroundings. People spend less quality time with their families and in public areas almost everyone is busy with their phones. This again demonstrates the contradictions of technology. We become more social with people that are far away, and less social with our direct surroundings.

1.4.2 The vision

These downsides of technology are inevitable. It is about how to deal with them and how to let them affect your mood and actions. Many people do not notice the bad side and are just focused on the good. Therefore the vision for the future interface on the skin is that it should create awareness for the user on his/her actions, both on- and off-line.

“The user should become more aware of his/her actions, either on- or offline”



1.5 Narrowing the domain

1.5.1 Clusters

We used the clusters to create a vision for our future product. Another purpose of these clusters is that they can help to narrow the domain. The context factors in appendix A, describe a domain that is too broad. There is not yet a purpose that the interface on the skin should fulfill. By focusing on one of the context factors, the idea generation which will take place in the next chapter, can be narrowed down to a more specific part within the broad domain that we have now.

1.5.2 Choosing focus

To determine which cluster to choose, all clusters are put into the graph as seen in figure 1.2. To determine what should be on the axis, we look at our design goal and at our 'bigger picture', found in the previous part.

In the design goal it states that the interface on the skin has to be useful. Useful is a somewhat vague concept, since products can be useful for some, but do not have to be for others. In general, solving

a problem is being considered as useful. As was evident in the bigger picture that was found, there are a lot of contradictions within the clusters. Some make life easier, and some cause problems. Therefore, problems and solutions are a characteristic which can be placed on one axis. Since our product should be useful and thus solve a problem, we want to focus on one of the clusters that is marked as being problematic.

Another contradiction found in the clusters is that some are focused on the individual, and some on society. Since our interface on the skin will be focused on the individual, we want to address a cluster that is also about the individual.

Now we know what should be on both axis, we can add the clusters, which is visible in figure 1.2.

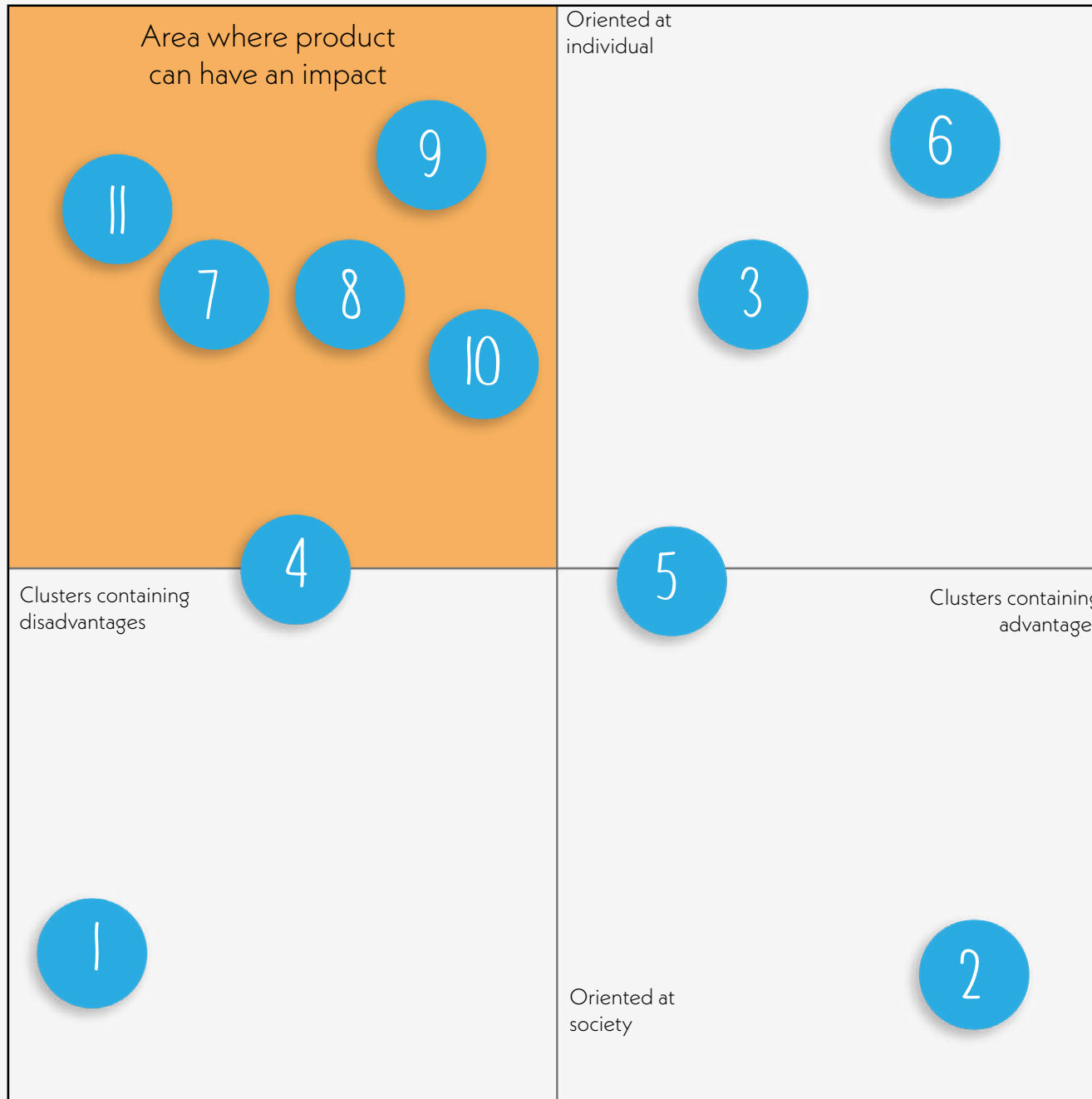

Figure 1.2: all clusters placed in the graph.

1.5.3 Clusters

1. Technology is causing global environmental problems
2. Technology is improving humanity
3. A human response to technology
4. People are more polarized in their opinions
5. The world is becoming smaller and people's lives are more connected
6. Technology empowers people to be more independent
7. There is more influence of others on your way of living and your thoughts.
8. Technology is constantly changing the shape of jobs and products.
9. People are becoming less responsible and more dependent.
10. People live more in the digital world than in the real world.
11. People are overwhelmed by the amount of stimuli they receive.

1.5.4 Choosing

The clusters that are situated in the upper left corner (orange) are the most interesting: these clusters contain both a problem and are focused on the individual. From these five clusters, number 9, 10 and 11 are considered to be more reachable to tackle within this project.

From these three clusters, number 11 has my personal preference. Overwhelming experiences by technology is something that can result in serious difficulties for people. This cluster also contains a lot of opportunities to diverge into different sub-directions, which makes it well suited for this project.

Domain of focus

“The overwhelming effect of the stimuli received by technology”

1.6 The effects of technological stimuli

1.6.1 Why technology can be overwhelming

The domain that fits best with this project, is about the overwhelming effects of technical stimuli. To get a better understanding of this category, some research is required on the causes and effects of technological stimuli.

That people nowadays receive a lot of stimuli is common knowledge. As Edward Hallowell states in his paper *Overloaded circuits* (2005): Never in the history has the human brain been asked to track so many data points. Everywhere people rely on their cell-phones, e-mail, and digital assistants in the race to gather and transmit data, plans, and ideas faster and faster. Stimuli are signals that are sensed by the body through touch, smell, sight, hearing and taste, and have to be processed by the brain.

In the past, stimuli were mostly provided by things around us: conversations, nature, etc. Yet, with the rise of technology and the internet there is now an endless stream of impulses within reach. Luckily,

the system (brain) acts like a filter, only letting the most important impulses pass. (Researchers at the helmholtz association) Although our brain seems capable of handling and filtering this increased amount of impulses, the origin of these new kinds of impulses have some negative effects.

These effects come down to three categories, which are:

- **Distraction**
- **Addiction**
- **Mental exhaustion**

1.6.2 Distraction

Our brains are designed to always seek for new information. (Eric Barker) And technology provides an unlimited amount of new information for the brain. It is no wonder that we get distracted quickly when our phone buzzes, since it means new information for the brain. According to Microsoft (*Microsoft Attention Spans Research Report*), our attention span has decreased from 12 seconds in 2000, to 8 seconds in 2013. The most important causes are: Multi-screen working, social media, technology adoption and the increased volume of media consumption. The brain gets used to this increased frequency of impulses, which means it starts to look for new impulses whenever they do not receive the usual amount. This means a short attention span and becoming easily bored. People experiencing more difficulties to maintain focus, or finding old movies too boring are two resulting examples.

1.6.3 Addiction

Addiction in general is mainly caused by the brain producing too much dopamine, and getting used to this new amount. There are two important factors that the brain causes tech addiction.

Social interaction

A key feature of our success as a species, is that humans evolved towards social creatures. (Heynes, 2018) Smartphones now allow us to carry immense social environments in our pockets. Apps (especially social media), uses this human aspect, to trick us into thinking we are socially active when we use these apps. As a result, the brain rewards this (fake) social behaviour with dopamine, which makes the use of it addictive.

Achievement

Rewards or achievement are also aspects that the brain rewards with dopamine. (Heynes, 2018) Games, but also social media, use this to keep people engaged with their platform. As visible

in figure 1.3, the brain not only creates dopamine when a reward is gained, but also when expecting a reward. Therefore people check their phones every minute when they have uploaded a photo: waiting for the likes already creates dopamine in the brain. A lot of games use the element of rewarding through providing continuous small rewards for playing. As a result the brain constantly creates dopamine, which results in addiction.

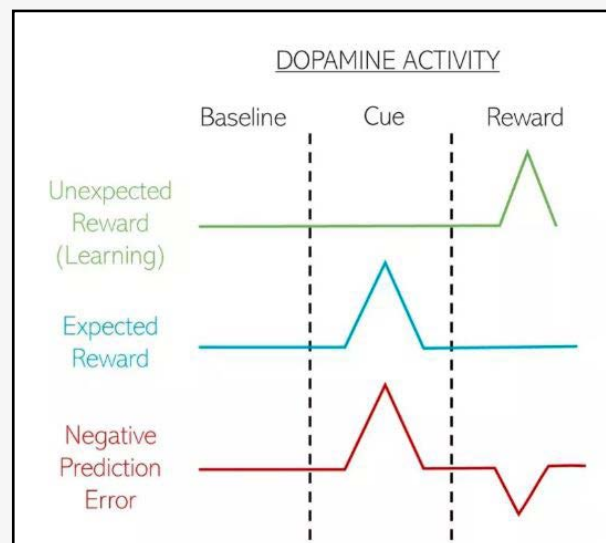

Figure 1.3: The different stages of rewards where the brain creates dopamine.

1.6.4 Mental Exhaustion

Besides distraction and addiction, these new impulses can also cause exhaustion in the form of stress, burn-out or depression. Mental exhaustion can be caused by three effects.

Overload

Overloaded individuals feel that they not only have to work more but also have to work faster to cope with the amount of information available in the social web (Wang et al. 2008). Overload can trigger stress, frustration and dissatisfaction; overload often also results in a feeling of loss of control over a situation and sometimes in feelings of being overwhelmed. (Brod, 1984)

Invasion

Different parts of life 'invade' each other, for example if you receive work-related messages at home. This can lead to increased distress, a less satisfying family life, poor decision-making, particularly in the course of performing complex tasks and, burnout syndrome. (Weil & Rosen 1997)

Uncertainty

Technology constantly reminds us of what we do not have or what we are not. There is so much choice and so much to achieve, and technology constantly reminds us of that. This is proven in an study by Perdouly et al., (2015), who showed that women have a more negative mood and worse image of themselves after spending time on Facebook. Women compared themselves on appearance, social status and life experiences.



1.7 Design of desired interaction

1.7.1 Introduction

Now we have a vision and a clear domain, we can look at how the desired interaction between the user and the new product should look like. Hekkert (2011) states that the interaction is something you aim to achieve, and that the product is just the mean to reach that desired interaction. Therefore to design the product, the character of the desired interaction should be determined before. What can help us to do this, is to create an analogy. This analogy makes it easier to think about how you would like your interaction between user and product to be, since you have a reference to compare to. Moreover it might provide new insights concerning your own interaction, which otherwise you maybe wouldn't have thought of.

1.7.2 Habits

The vision for the future interface on the skin is that it should create awareness for the user on his/her actions, both on- and off-line. Awareness can mean many things. You can be aware of people or surroundings, but also of behaviour. Being aware means being more in the moment, and thinking about what you are doing and what its consequences are. Actions with negative results on the long term can be related to this: They are often the result from unconscious actions. It is impossible to be constantly aware, and to think about every action you take. This would ask too much energy from your brain. Luckily our brain developed a trick to avoid thinking about everything you do all day, which are called habits. Habits are actions you perform so often your brain is able to remember them without consciously thinking about it. An example of a habit is brushing your teeth: you remember to do it every day, yet when you think about it, it is not really clear why you remember this. There is no reason for you to think about brushing your

teeth, and yet you do. This is called a habit, which takes between 21 and 254 (average of 66) days to create. (Lally et al., 2010) You need to repeat an action many days continuously before you do them without conscious thinking. To execute the same behaviour for that many days continuously, most people need a little bit of help. This external guidance can, for example, be an app that functions as a reminder, or it can be an already existing habit that you connect to your new habit, and the old habit will help reminding you of the new one.

1.7.3 The approach

An easy way to change behaviour is through punishment. And although punishment is an effective way to change outward behaviors in the short term, punishment has limited outcomes beyond changing observable behavior, and many behavior change experts frown on using it. (Fogg, Cuellar, Danielson, 2007) Since our behavioural change goes beyond the observable, creating awareness and (hopefully) a new mindset, a positive attitude

is more preferred here.

With positivity in mind, the following 4 keywords on the next page describe the essence of how I would like to see the interaction between the user and the future product.

Fitting analogy

“The relation between someone and his personal trainer at the gym”



Figure 1.4: The analogy of a pe



Person and his personal trainer

1.7.4 Description of analogy

With these characteristics in mind an analogy can be created. The interaction that is desired between a user and an interface on the skin, can be compared as an analogy to one between a person and his personal trainer at the gym. The personal trainer has to be **motivational**, which is something that is needed to prevent giving up.

He has to be **constructive** in his feedback, since the tone of this feedback is something that can either motivate or demotivate someone.

A personal trainer helps someone to become more **conscious** about his habits and the consequences of those habits for their body.

Small and **realistic** steps end with the most results, since you're less likely to give up.(Fogg ,2009)
Failing heavy exercises results in demotivation. The personal trainer is there to help in reaching the goal through a realistic approach.

Motivational

To give the user purpose and help to prevent giving up to achieve behaviour change

Constructive

It should be constructive and positive, to make the change towards new behaviour experienced as a pleasant one.

Conscious

It should help te user to become more aware: It should create more consciousness with the user

Realistic

It should be realistic, both in its goal as in its way of reaching that goal.



1.8 Defining interaction qualities

1.8.1 Approach

Possible new insights can be gained on the desired interaction between user and product, by observing the analogy. The analogy of the user and the personal trainer at the gym contains many factors that are influencing this relationship and the general experience of going to the gym, which might apply to our desired interaction as well.

Finding and looking at these factors could reveal new insights about our own interaction, which might have been overlooked or found much later on in the process.

In appendix B, a small brainstorm can be found on factors that influence the experience of going to the gym, and for the relation between user and personal trainer.

1.8.2 Insights

Looking at these factors, an important insight came to my mind. Not only do all these factors influence the experience of the user in the gym, they are all key elements that determine whether someone stays dedicated to the gym and trainer, or decides

to leave. If only one of them becomes too negative, the user will probably decide to leave. This is an key element for our desired interaction as well: If the product contains one or more elements that are perceived as negative for the user, he will not use the device. It means that user adaptation is just as important as the functioning of the device. Without looking at and analyzing this analogy, this important factor might have been overlooked, or found much later in the design process. In the Second part of the exploring context and direction, on the personal level, it will be described which factors exactly are important and that have a good user adoption as result.

“User adoption is a key factor in the design process of the interface on the skin”



1.9 Conclusion societal analysis

1.9.1 Finding a vision

Using a VIP inspired method, a vision has been created that captures the core of the desired future interaction between the interface on the skin and the user. This resulted in the following vision: People should be more aware about their on- and off-line actions.

1.9.2 Narrowing the domain

Using the factor clusters that were also used to create a vision, a more concrete working domain has been determined. This was done by placing all factor clusters on a spectrum, to determine which fitted best with this project brief. The domain that the focus will be on from now is: The overwhelming effects of the stimuli received by technology.

As discussed before, there are quite some negative effects related to these technological impulses people receive nowadays. Together with the vision, this domain can lead to a new design goal: reducing the amount of negative technological

impulses through the creation of awareness. This goal should be reached through a positive approach, to gain results that are more oriented at the long term.

New goal

“Reduce the amount of negative technological impulses through the creation of awareness”

This new design goal, and the analysis of the analogy result in two important factors that the future interface on the skin requires to abide to:

1. It should seduce the user in some way to adapt to this new wearable: If no one wears it, it is not capable of having any impact and evoking change.

This factor has been derived from the analogy: analyzing this analogy resulted in an insight that user adaptation is an important element which should be kept into account in the design process early on, and should be tested through user testing during the defining solution phase.

2. It should be capable of changing the users behaviour.

This can be derived from both the vision and the diverged domain, which resulted in a new design goal that aims to reduce the users impulses that are gained from technology.

Both these factors are occurring at a more personal level and have to be evoked per individual. The following chapter will scale down from society to the individual, and explain how these two key factors could be taken into account in the next steps of the design process.

2

**Personal
analysis**

2.1 Introduction personal analysis

2.1 Introduction

In this chapter the context will be analyzed on a persona, user oriented level. This chapter is creating the bridge between the desired vision and the product functionalities, by analyzing the two elements that chapter one concluded with. This will not yet result in physical properties for the product, but it will provide guidelines on social factors that are important to reach the desired vision and design goal.

The societal analysis provided us with a vision and a domain. Combining these with the original goal resulted into a revised goal: decreasing the amount of technological impulses to benefit the mental and physical health of the user, through usage of an interface on the skin. In order to reach this goal, two things are of importance, which will be explored in this chapter.

1. The willingness of the user to adapt to this interface on the skin

As concluded in the previous chapter, reaching the desired interaction requires commitment from the side of the user. Not only should the user be tempted to adopt the new device, he/she should also stay committed over a longer period of time.

2. The ability of the interface on the skin to motivate and persuade the user to adjust his behaviour, through creation of awareness.

If the user is committed, it still does not mean that behaviour change will occur. The device might not function well but still look good, which could be a reason for people to keep wearing it. In this sub-chapter some key elements of persuasive design will be discussed, that could help the interface on the skin to reach the goal of behaviour change.

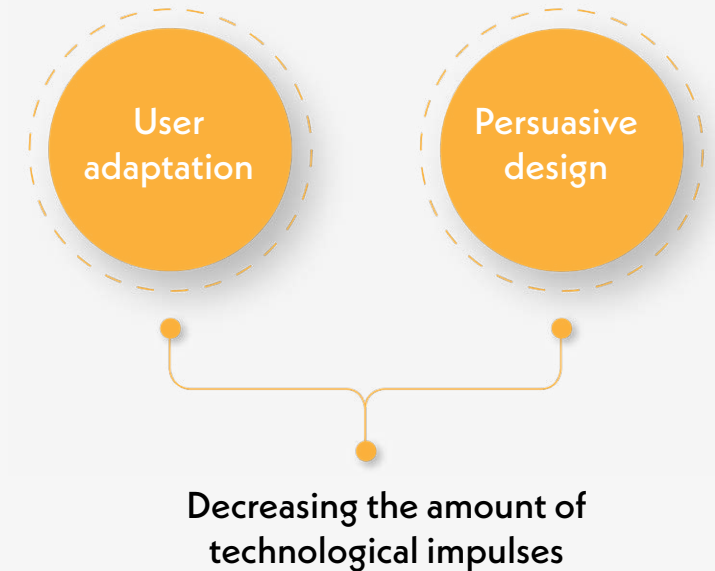



2.2 User Adaptation

2.2.1 Introduction

As already mentioned, the analogy characteristics all have in common that they can contribute to individual commitment. Since this is also a key element in our interaction, it would be valuable to know what determines the user adaptation for technological wearables. This is described in by Buenaflor and Kin in their paper: Six human factors to acceptability of wearable computers. They describe six factors that together determine whether a person will accept and adopt a wearable computer or not.

2.2.2 Six factors for wearable adaptation

Interesting enough, all factors that influence the experience when going to the gym, fit with one of the six factors for wearable adaptation as well. This provides three new insights

1. The analogy fits well with the desired interaction. The characteristics that determine whether someone commits to a personal trainer, correlate to the factors that determine whether someone commits to a wearable.
2. It confirms that wearable adaptation is important for the whole concept to work, just as commitment to the gym is required to get to results.
3. The six factors provide space for further research on key aspects of what is important for acceptance of the user to the wearable.

**Functional
needs**

**Cognitive
attitude**

**Social
aspects**

**6 factors that determine
user adaptation**

**Physical
aspects**

**Demographic
characteristics**

**Experience
with the topic**

2.3 Functional needs

This factor describes the six hierarchical needs, as described by Maslow (1943, figure 2.1). These needs are examined by Duval et al (2010) in a study about the relation between the needs and smart textiles. The study showed that people are attracted to smart textiles containing one of the two primal needs: Physiological needs and safety and security.

Therefore having elements of one of those two factors in the product, will increase the likeliness of user adaptation. Ultimately the interface on the skin aims for the user to achieve a healthier mental state. Health is in the second layer of the Maslow pyramid, and thus something people are attracted to. An important note is that people should also be aware of the presence of this healthy element.

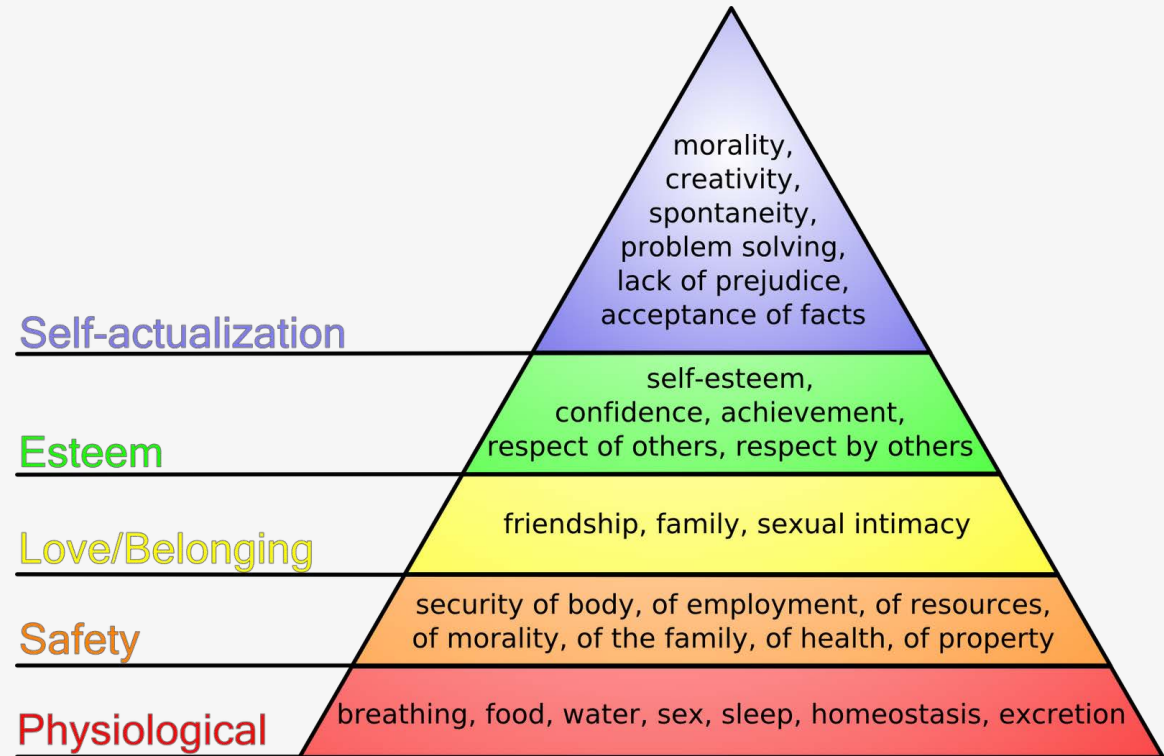

Figure 2.1: Maslows pyramid of hierarchical needs (1943)

2.4 Cognitive attitude

Buenoflor and Kim describe this factor as acceptance of technology, and use the Technology Acceptance Model (Vankatesh and Davis) (figure 2.2) as a way to define what is acceptance. This model focuses on two factors essential for the acceptance of novel technology.

2.4.1 Perceived usefulness

The perceived usefulness relates to the perception of the user on how well the wearable is capable of helping to enhance the performance on a certain task. This perception is based on pros and cons of the device. A device might enhance a person's performance on a certain task, but cause complications on another part of his/her life. As long as this person believes that what he/she gains is more important than what he loses, the device will be considered useful.

2.4.2 Perceived Ease of use

When a technology is easy to learn and operate, users will be more comfortable and confident in using it, thus it is more likely to be accepted. (Buenafior & Kim). On the other hand, if a system is perceived to be complicated and difficult to use, users tend to become anxious and worry about making mistakes that would cause harm, since the device is worn on the body. This expected danger leads to lower confidence in using the device. (Schaar and Ziefle)

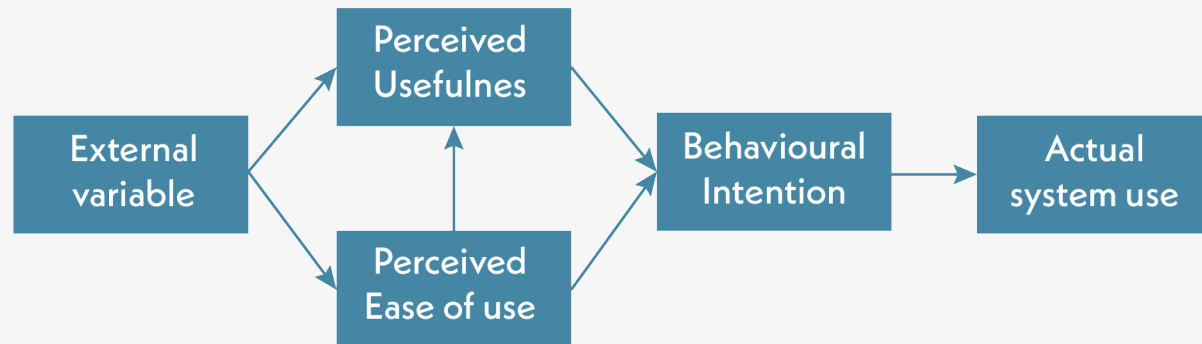

Figure 2.2: Technology acceptance model

2.5 Social aspects

2.5.1 Two factors

Social aspects concern everything that has to do with the relation of the user with other people, that can influence how the user perceives or enjoys the product. Buenaflor and Kim describe two important factors:

2.5.2 Privacy

Privacy is a critical issue, particularly in an environment of ubiquitous and pervasive computer use (Kurkovsky et al., 2008) People are cautious in sharing personal data with others. According to Boscart et al, (2008) comfort and security in accessing and sharing data are important factors in the acceptability of the wearable device. Transparency of which data is being collected and what is done with it is essential. If this is ambiguous, people are more suspicious and cautious with sharing their data.

2.5.3 Influence of others

The impact a gesture can have on a social situation is expressed by Toney et al., (2003) as social weight. For example executing a voice command while in a conversation is something that has a big social weight, since it disrupts the conversation. According to Toney et al, (2013) this social weight depends on :

Cognitive load

How much effort does it take to perform a gesture?

Physical presence

How present is the technological device and the interaction?

Technology apprehension

How much do others know and understand the technology and gestures?

Social convention

What is socially accepted in the context that the user is in?

Being aware of this social weight during the design process is important. It can be avoided or can be used in the design.

2.6 Physical aspects

2.6.1 Important properties

The physical aspect concerns everything that has to do with the physical properties of the wearable. Buenaflor and Kim use the following three key points to describe how the physical properties of a wearable affect user adaptation.

2.6.2 Comfort and safety

Comfort and safety are two essential aspects for user adaptation. Comfort is determined by the portability and wearability of the device. (Rosenthal et al., 2018) Important aspects are weight, size, and how it affects the users movement. A device that has minimal weight, shape and movement constraints, while it still executes its function properly, is preferred by people. (Bodine and Gemperle, 2003) Another barrier is safety. People might experience fear for the possibility of a technical failure. (Boscart et al., 2008)

2.6.3 Aesthetics and experience

Aesthetics of wearables define a group identity. Other people identify you as being part of a certain group, based on your looks. For wearables, this could be handicapped, sportive or high-tech, depending on aesthetics and context. (Dunne, 2010) With wearing certain products, the wearer wants himself to be associated with a group, which expresses his self image. Self-image affects the way we feel about ourselves, which may increase or decrease self-confidence, and thus is important for wearable adaptation. (Dunne, 2010) In figure 2.3 it is visible that an identity is formed by aesthetic characteristics of the product and the user, within a given context.

Wearable products have two types of aesthetic characteristics:

- Expressive: Their shape, color etc
- Referential: created by the viewer. What do they think of it and refer it to?

The identity that is assigned by others always depends on a combination of user and product, which cannot be seen separately. An example is a bandana, which worn by one person can define this person as a biker, whilst being worn by someone else can define him as a surfer. The addressed identity depends on the wearers and product properties, within a specific context. Bell (1992) described this context as "sartorial morality" the codes and mores established by a society that govern "appropriateness" of dress. What is appropriate in one context, might not be in another, and thus a different identity can be ad-

dressed to this person. A surfer in the water might be identified as just a surfer, while a surfer in the city might be identified as someone who wants to express his relaxed attitude and mindset.

2.6.4 Mobility

Mobility of the wearable is an important physical characteristic as well. If the wearable requires a connection of some sort, or requires to stay in the same location in order to function properly, the device is not mobile which decreases user adaptation.

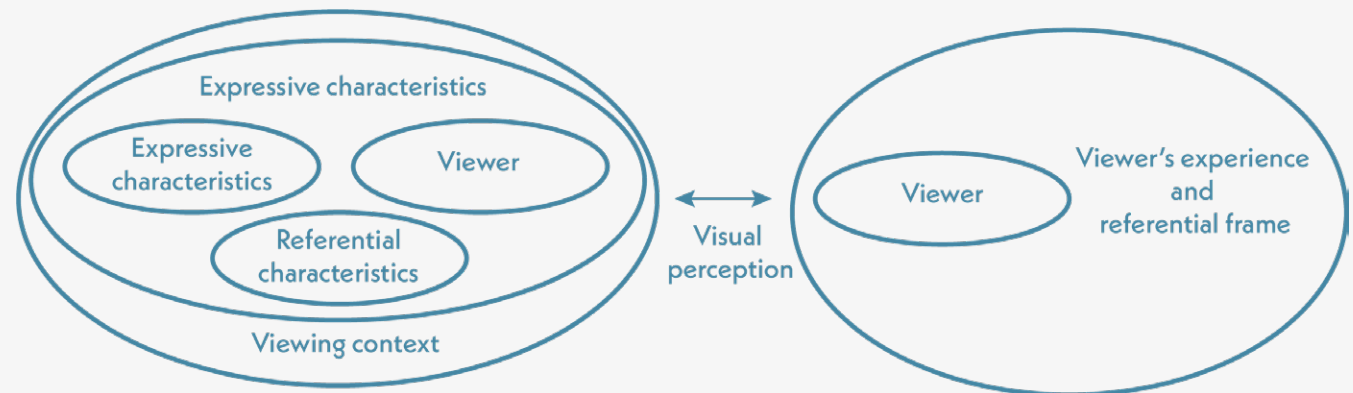

Figure 2.3: Assignment of group identity

2.7 Demographic characteristics

A very logical aspect of wearable adaptation are demographics. One might have an income that does not allow for purchasing such a wearable. Another demographic constraint is for example elderly people, who are not accustomed to technology and find computer systems difficult to understand. (Steele et al., 2009) Rudell (1991) found that women believe that they were less knowledgeable about science and technology and a higher proportion of men have a high level of interest in the use of new inventions and technologies. Demographic characteristics affect user adaptation and a wearable should be designed that fits all different demographic groups within a certain target group.

2.8 Technological experience

Knowledge on current technology and the wearable itself is essential to understand and embrace these new technology devices. One person might not be able to control a wearable since he is not familiar with used or similar technology, hence doesn't see the benefits of the wearable, while someone who has experience with similar devices finds it easy to control. These results in more confidence which is a more positive feeling towards the wearable and therefore this person is more likely to adapt the new device. An example that substantiates this is given by Duval et al., (2010), who concluded that there was much more interest for smart clothing in Japan than in France. This can be attributed to the fact that Japanese people are much more familiar with technical devices compared to the French.

2.9 Summary 6 factors for user adaptation

Functional needs

Duval et. al. (2010) discovered that people are strongly attracted to wearables offering one of the two primal needs from the hierarchy of needs (Maslow)

- Containing one of the two primal elements from Maslows hierarchical pyramid of needs.
- Expressing this element to the user.

Cognitive attitude

This describes the user's attitude towards the new technology in terms of perceived usefulness and ease of use

- There should be more advantages than disadvantages (perceived usefulness)
- People should be confident in using the device (ease of use)
- People should not fear wrong usage (ease of use)

Social aspects

Other factors that might influence acceptance such as social or cultural influences, or privacy related matters

- Data collection should be clear and transparent (Privacy)
- The social weight should be at an acceptable level (influence of others)

Physical aspects

Does the wearable look appealing? Is it comfortable? Is it safe? All aspects in relation to the physical properties of the product

- The device should not restrict people in their movement
- The product image should fit with the group identity that people want to express with this product
- The device should be appropriate for the contexts that it will be used in.

Demographic characteristics

Age, sex etc that influence the adaptation of the wearable)

- The benefits of the device should be experienced in the same way by different demographic groups

Experience with the topic

Experience with similar products

- The device should contain characteristics that are already known to people, such as swiping or moving the fingers to zoom in.



2.10 Persuasive design

2.10.1 Introduction

Now we know what is needed for people to adapt to the new product, it is also valuable to gain insight into how to persuade people towards changing their behaviour.

In this chapter the latter will be discussed. As mentioned before, creating awareness has as a underlying purpose to change a behaviour. This can be done through habit creation or alternation.

2.10.2 The behaviour model

To change a behaviour or learn a new one, three important factors are required, which are presented by B.J. Fogg in his behaviour model. (A behaviour model for persuasive design, 2009) This model describes what is needed to persuade someone into taking a certain action or change a certain behaviour. In this model, which is visible in figure 2.4, two key factors are placed on the axis: motivation and ability (simplicity). In this graph, an actuation line is drawn and when the user finds

himself in a position in the graph that is above this line, a trigger will activate him to take action.

In this model, motivation and ability are intertwined, which results in the boundary line being a slight curve going from the upper left corner to the lower right corner. Being intertwined means in this sense that both factors can influence each other. If someone has a high motivation to do something, he might find ways to do it anyway. The other way around this works as well. If someone has a low motivation to do something, but it is very simple to do, he will be more likely to take action. An example is taking the car instead of the bike. One might want to bike, which means the motivation to take the car is much lower compared to taking the bike. Yet taking the car is much easier, since it saves time and physical effort. Although the motivation to take the car is very low, one will probably still choose this option since it is easier.

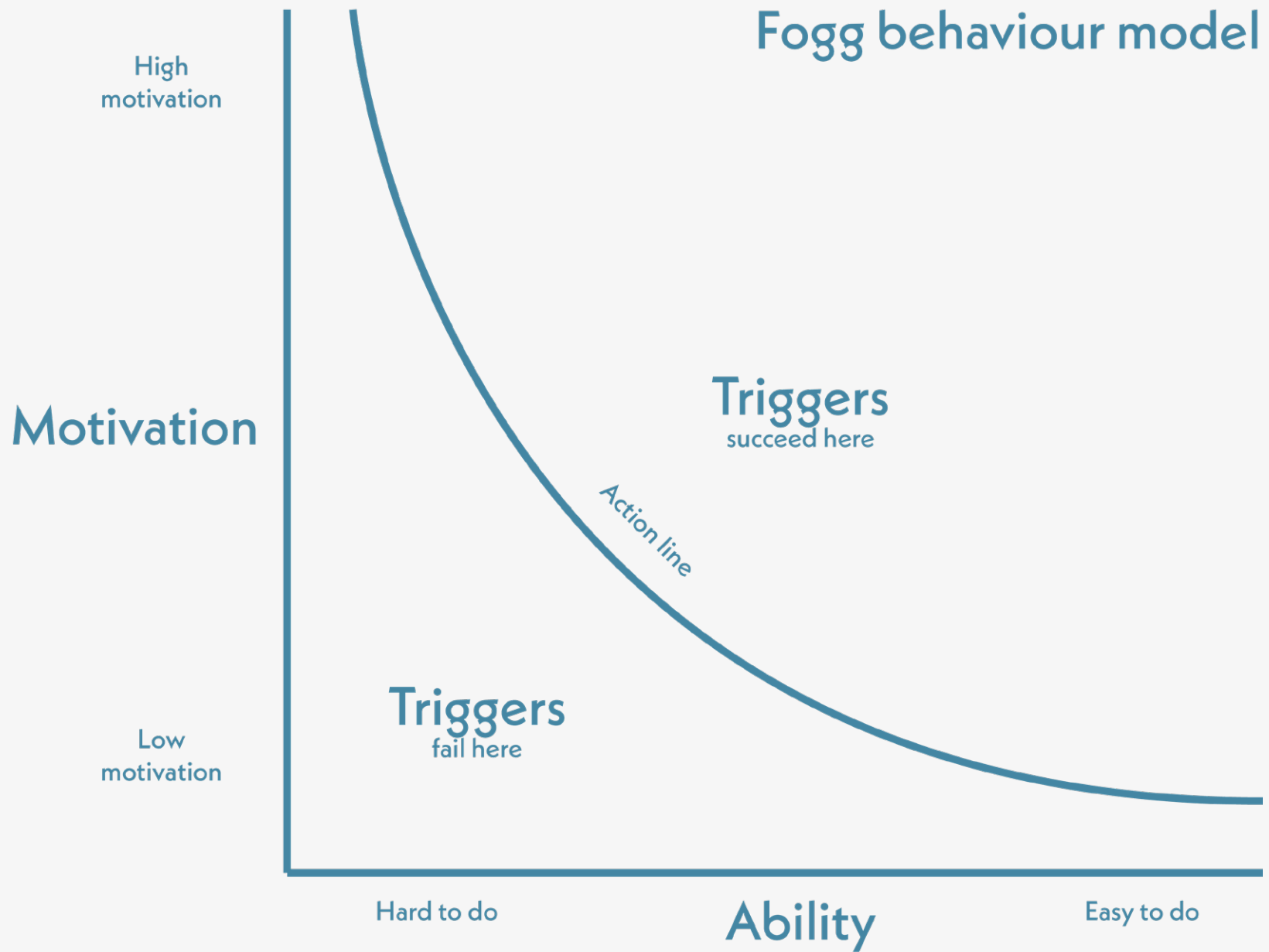

Figure 2.4: The behaviour model, by B.J. Fogg

2.10.3 Motivation

A first important factor for behavioural change is motivation. Having low motivation makes it unlikely that someone will adjust his behaviour, and having high motivation makes it more likely that he will. According to Fogg (2009), motivation comes in three different shapes:

Pleasure/Pain

Requires almost no thinking and responds to the moment: You get rewarded, which motivates to continue behaviour or get punished which demotivates.

Hope/Fear

Taking action because you hope for a certain outcome, or to prevent something from happening.

Social acceptance/Rejection

Taking action to become or stay part of a group.

2.10.4 Ability

On the other axis there is ability, or simplicity. This describes how easy it is for someone to take action, measured at the moment the trigger occurs. If you have a high motivation to visit relatives since you haven't seen them for a long time (motivation), but you are only reminded to do so when you pass their house (trigger) when you're on your way to work, you will have a low ability to do so. Other times you might have time to do so, but at those moments there is no trigger to remind you of your relatives. Therefore ability is measured at the moment a trigger occurs. According to Fogg (2009), there are six different factors that together determine ability and that all need to be present in order to take action. It should also be noted that for one person it is easier to take action as it is to someone else. A 55-year old has more money compared to a 20-year old and therefore it is easier to go on for example a holiday.

The six factors are:

Time

If there is no time at the moment a trigger occurs, no action will be taken.

Money

Having little money can prevent someone from taking action as well.

Physical effort

If an action requires a lot of physical effort, it becomes less simple to execute.

Brain cycles

If something requires a lot of intensive thinking, it might not be simple to execute.

Social deviance

If an action requires someone to go against the norm, it becomes less simple.

Non-routine

People often stick to their routine. If they do something that is not part of that routine it requires more effort.

If all these factors concerning a task are considered simple, the task itself is considered as being simple.

2.10.5 Trigger

If the combination of motivation and ability is high enough (if the user can be found above the line in the graph), a trigger causes the user to take action. But even if motivation and ability are high, the user still might not take any action. If someone has high motivation to visit relatives, and has the ability, he still might not do so, since he is not thinking about it at that moment. A trigger can therefore be seen as a call for action: it tells the user to do something. If a trigger occurs but ability or motivation are low, this works in the opposite way and might be considered as annoying or frustrating.

Triggers come in three different ways:

Spark

A spark is a trigger that reminds you of your motivation. For example, putting 20 euros in your savings account every time you see a photo of the place where you will go on holiday when you have saved enough.

Facilitator

A trigger that makes a task easier. An example

mentioned by Fogg is that of installation software. The software makes this process so much easier for the user, that it just requires a few clicks.

Signal

This last trigger can be used when both motivation and ability are high enough. It will simply remind the user that specific moment is the right time to take action.

2.10.6 Changing a habit

Now we know better why people perform certain actions, but not perform others, we can have a look at how we can use this to change behaviour. There are two ways of changing a habit. One is decreasing the current habit, and the other is changing it into/or adding a new one. Decreasing a habit can be done by taking away motivation, ability or the trigger. Think of silencing notifications on your phone (taking away trigger), or increasing the tax on gasoline (decreasing ability to drive a car). Adding a new habit can be done by attaching it to an already existing one. For example, every time you set an alarm to go to bed, a notification will remind you to read a book for 10 minutes. Eventually you won't need the reminder anymore and simply setting the alarm reminds you to start reading a book for 10 minutes.

2.10.7 Credibility

According to Fogg, Cueller and Danielson (2007), credibility of the interface is a key element in

persuading people. Just as people require credibility and believability to persuade others, so do interfaces. Seven categories are described where credibility is important:

Fogg, Cueller and Danielson (2007) provide tips to convey credibility to the user, through an interface design:

When interfaces act as knowledge repository

The data that is being provided should be reliable.

When interfaces instruct or tutor users

They should teach the right things.

When interfaces report measurements

These should be accurate.

When they report on performed work

For example whether a software package is installed correct.

When interfaces report about their own state

For example how much battery is left.

When interfaces run simulations

For example flight simulations that need to be realistic.

When a virtual environment is rendered

Credibility is important to make this environment believable.

2.11 Conclusion personal analysis

2.11.1

This chapter discussed two key factors that are required on a personal level, in order to reach its goal of reducing the amount of negative technological impulses through the creation of awareness. The product should be adapted by the user. The design should persuade the user into behavioural change.

2.11.2 User adaptation

According to Buenaflor and Kim, there are six different key aspects that determine user adaptation of a new smart wearable. All six are important and cannot be neglected during the design process.

Functional needs

Duval showed that users tend to adapt quicker to devices that contain one of the two most primal human needs, according to Maslovs hierarchy of needs. Therefore the product should address one of the two primal needs, and make the user aware of it.

Cognitive attitude

The interface on the skin should be easy to learn and control, and it should be perceived as useful in a sense that it fulfills its intended function.

Social aspects

The user should not have privacy concerns while

using the product. The social weight of the interface on the skin should be at a level where people accept the device in public situations.

Physical aspects

The device should be comfortable to wear and should conform the user that it will not harm him in any way. Wearing the interface on the skin should allow the user to create a self-image in which he feels secure. The interface on the skin should allow the user to be mobile.

Demographic characteristics

Different demographic groups experience the functions and advantages of the device in the same way.

Technical experience

The product should contain elements which are already familiar to people.

2.11.3 Persuading design

According to Fogg (2009) and Fogg, Cueller and Danielson (2007) there are several key elements that need to be present in order to make people become aware of something, and eventually change a behaviour.

There should be motivation, ability, and a trigger to persuade the user to take action. The interface can take several roles in this, as being the device that provides one of those three factors. In this, credibility of the interface is of big importance to achieve change. The device can also take the

opposite role, by taking away one of these elements from a current habit, which would result in non-routine and eventually loss of the habit.

2.11.4 Next steps

The information gathered in this chapter can be used as a foundation for the user tests in the defining solution phase. Are all the elements for successful user adaptation present? And does it persuade people to change their behaviour? The presence of all aspects mentioned in this chapter can be tested through user tests.

Technological analysis

Now we know which aspects are needed in the product to reach the design goal, we can go one step further, to the product level. This contains the technical aspects of sensing on the skin. What kinds of possibilities are there for sensing and actuating on the skin, and what are their (dis)advantages? This will be discussed in the next chapter.

3

**Technical
analysis**

3.1 Introduction Technical analysis

To create a better understanding of current developments of sensing and actuating on the skin, a research course has been conducted prior to this graduation project. The goal is to gain more insights on promising developments, and to decide which developments are interesting enough to use as inspiration for this graduation project. To make this decision, a method is used which is inspired by the Harris profile (Harris, J., 1995). In this method, all devices are rated on predefined criteria, which allows them to be compared (Appendix C). Since all devices contain different functions, it might be hard to compare them. Therefore criteria are used that are derived from the design goal, and are not influenced by the function of the device:

- Conforming to the rounding of the body.
- Being comfortable to wear.
- Being stretchable, up to 32%.
- Customizable

One criterium is added which can be derived from the deliverable of a functioning prototype in the end of the project:

- Being constructible at the TU Delft, within the given time period

These criteria allow all found sensors and actuators to be compared and ranked. To decide which devices to continue with, two things were important:

- The overall ratings based on the above-mentioned criteria
- Offering a wide enough variety to continue with

This resulted in two sensory devices, and 5 actuators that were interesting enough and offer a wide enough variety to generate ideas within the exploring solution space. These sensors and actuators, and their underlying principles, will be briefly explained in this chapter.

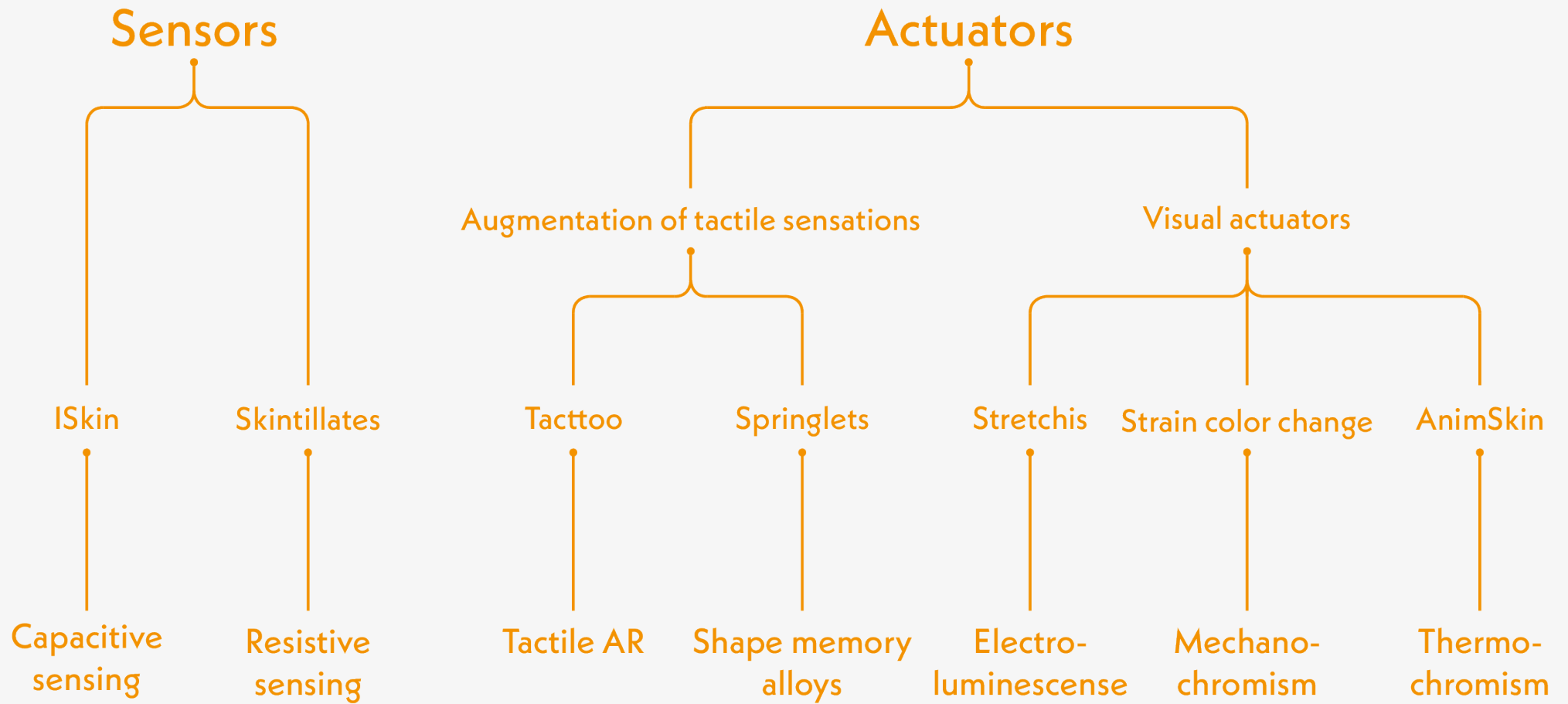



Figure 3.1: An example of electroluminescent material

3.2 Capacitive sensing

3.2.1 Components

Capacitive sensing allows for measuring touch and proximity. A capacitive sensing device can simply be made by attaching a piece of conductive solid material to a microcontroller that can measure capacitance, such as an arduino. A capacitive sensor senses if a conductive material is close-by or touching.

3.2.2 The capacitor

When a finger comes close to the electrode, the finger and the electrode will form a capacitor. (Figure 3.2) A capacitor is a device that is capable of storing energy. How much energy a capacitor can store, is expressed in Farads (F) and is called capacitance. The formula to calculate capacitance is $C = \epsilon \cdot A / d$.

Here, C is the capacitance measured in Farads, ϵ is the permittivity of the insulating layer (constant), A is the surface of the capacitor and d is the distance between the electrode and the finger. (figure 3.3) What can be concluded from this is that when a

conducting object is closer, d will become smaller and thus C will become bigger. There is a direct relation between the distance between finger and electrode, and the capacitance.

3.2.3 Measuring capacitance

Capacitance can be measured through a microcontroller, such as an arduino.

The arduino is capable of measuring the time it takes to charge the capacitor. From this time, the capacitance can be calculated, which then can be used to determine the distance of the finger, using the formula mentioned above.

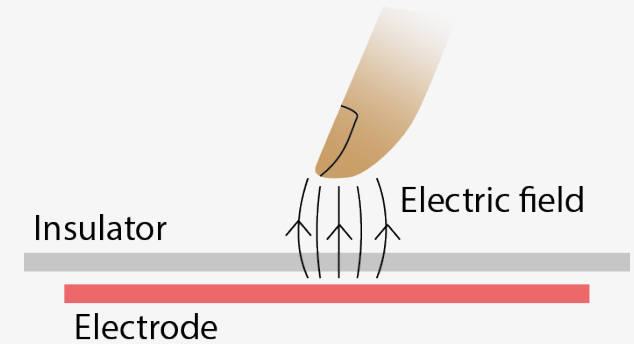

Figure 3.2: An electric field between finger and electrode

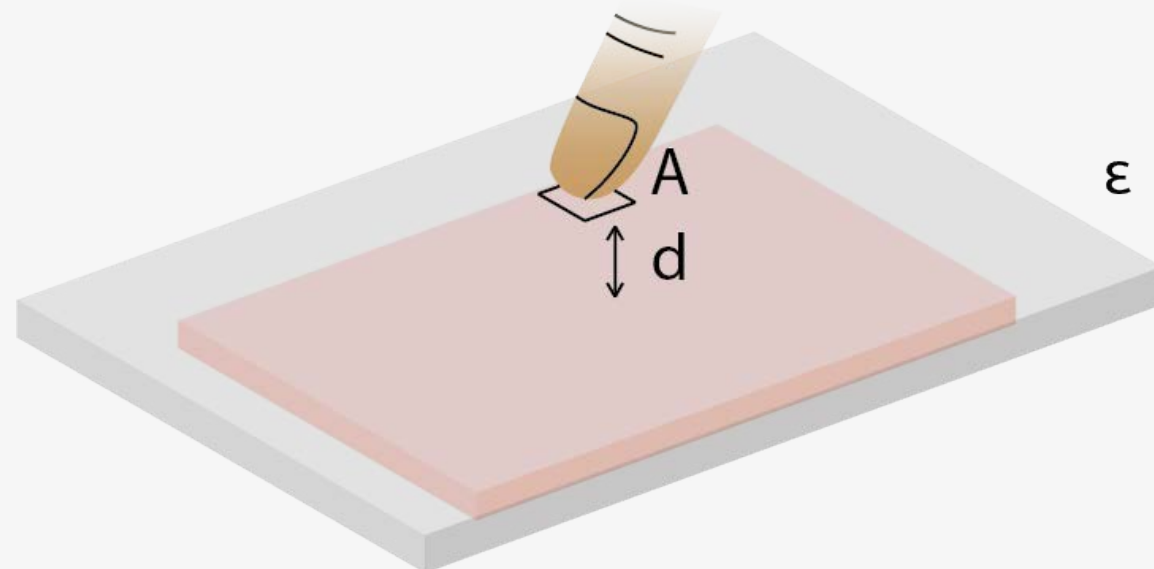

Figure 3.3: The parameters used in the formula for capacitance

3.2.4 Capacitive sensing on the skin

ISkin is a stretchable capacitive touch sensor. It consists of two parallel electrode layers, which are made of a carbon particle containing silicon. These two layers are separated by a silicone dielectric. The insulating layer in the middle contains holes, which allows the sensor to sense the difference between a gentle and a firm touch. When the sensor is touched gently, it will function as an ordinary capacitive sensor: It can measure a difference in capacitance. Yet when the sensor is touched firmly, the two electrode layers will touch which provides a distinctive signal.



Figure 3.4: Capacitive sensing used to control music

3.2.5 Stretchable capacitive sensor

The device Stretchis shows many similarities to ISkin. The difference is that the dielectric layer does not contain holes, and that a phosphor layer is added. This layer consists of a mixture between phosphor powder and silicone, and provides electroluminescent light. (More on electroluminescence can be found in chapter 3.8) To both sense and emit light, a technique called time multiplexing is used. This means that the devices switches really quickly between emitting light and sensing, which makes it seem like it is doing both at the same time. A more elaborate description of this device is given in the research report.

3.2.6 Location of touch

There are two ways of sensing the location of a touch-point through capacitive touch sensing:

- By creating separate small capacitive sensors, which function as buttons.
- Through usage of a matrix shaped sensor. In this matrix, one electrode contains rows and the other electrode contains columns. Every row and column is measured and if capacitance changes in one row and column, the touch-point will be on the crosspoint of those.

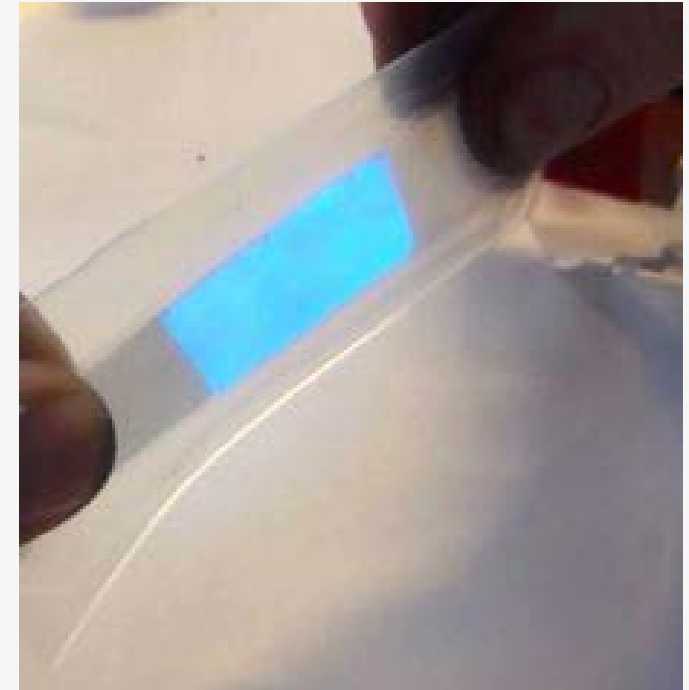

Figure 3.5: Stretchable electroluminescent device

3.3 Resistive sensing

3.3.1 Components

Resistive sensing is based on measuring a change in resistance in a material. In the paper Skintillates, resistive sensing is used to sense strain. Yet, there are more ways to use resistive sensing that allow for sensing touch and the location of touch on the skin.

3.3.2 Measuring resistance

Measuring resistance is a method that can be applied and which can have different goals. It could for example function as a simple touch sensor, to determine the location of touch, or as a strain gauge. All these functions are based on the same principle, which is measuring a change in the resistance of the material.

3.3.3 Skintillates - Measuring touch

To make a distinction between gentle and firm touch, ISkin uses both capacitive and resistive sensing. When the device is firmly pressed, two electrodes are pressed together through the dielectric layer which can be sensed. (Figure 3.6)



Figure 3.6: touch sensor

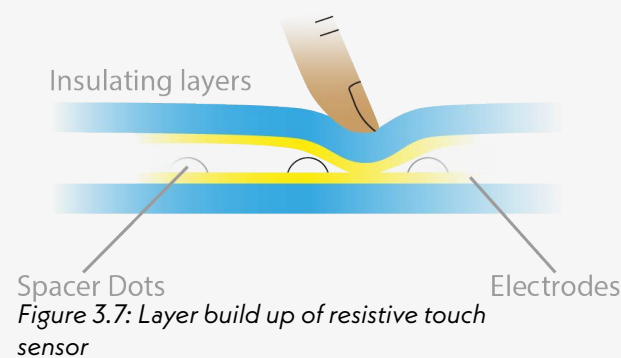

Figure 3.7: Layer build up of resistive touch sensor

3.3.4 Measuring strain through resistive sensing

A strain gauge is able to measure applied strain on a material. It can for example sense if a material is bent or not. It does this by connecting the material to a wheatstone bridge. This is a device that is able to measure the resistance by comparing it to already known resistance. Since stretch or bending adjusts the resistance in a material, this will be noticed and can be translated into information on the deformation of the material. This way of sensing is presented in the paper Skintillates. Skintillates is a device that is placed on a joint, and can sense if the user stretches this joint.

3.3.5 Determining point of touch

4-wire sensing can be used to determine the location of a touch-point on a surface. The build up is visible in figure 3.10. When applying a voltage on the top electrode, the bottom electrode is used as a sensor. (Figure 3.10) This works the same when applied the other way around.

The voltage in the top layer is applied on Y+ and goes to Y-, where it is 0. When the two layers are pressed together, the non-charged layer is able to measure the voltage at the touch-point. From this value, the y-coordinate of the touch-point can be derived. The same principle works to determine the x-coordinate. Sensing of x and y happens not simultaneously, but in very fast cycles. First one layer has a voltage applied and the other is the sensor, and then the other way around. This way x and y coordinates can be determined very fast and movement can be registered as well.

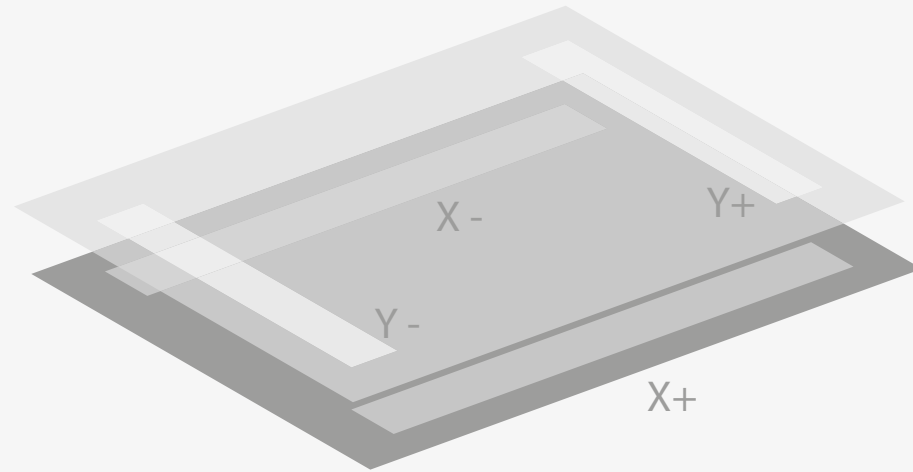

Figure 3.9: Sensing strain using resistive sensing

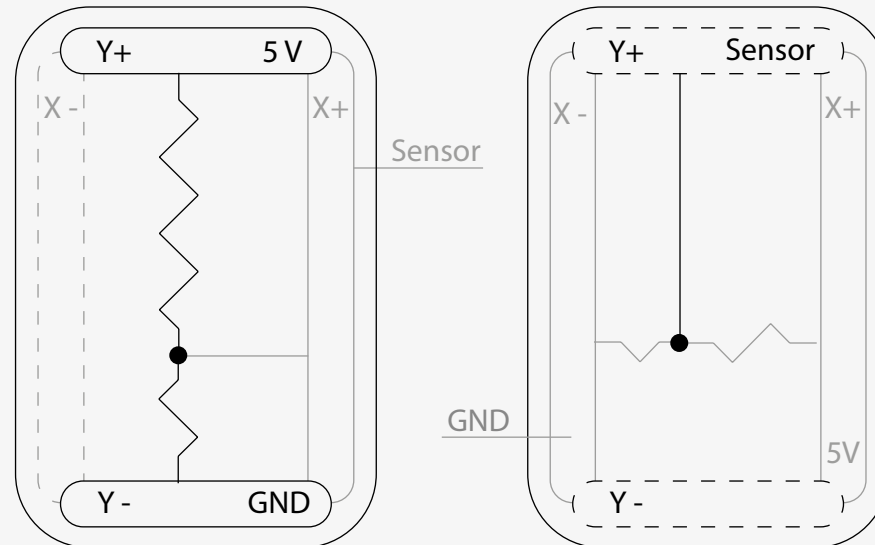

Figure 3.10 & 3.11: Sensing location of touch

Resistive sensing

Capacitive sensing

Advantages

Allows for sensing touch through pressure, therefore also an object such as a stylus can be used

Allows for sensing deformations through strain sensing.

The sensor values are not influenced by water, dust, etc.

Can sense movement of a touching object.

The skin can function as the grounded electrode layer

Making a conductive device stretchable brings less complications

Can sense the location of touch (when matrix shaped capacitive sensor is used)

Allows for multiple simultaneous touchpoints being sensed.

Has the capability to sense touch and proximity

Capacitive sensing has a high sensitivity

Capacitive sensing is capable of sensing circular and linear movement.

Resistive sensing

Capacitive sensing

Disadvantages

Not always reponses properly and sometimes requires a firm press

Therefore the device is also more prone to damage

Multiple simultniuous touch points are not possible with resistive sensing

Bending could cause unintentional touch of layers and creation of signals.

The capacitive sensor requires to be calibrated when placed on the skin.

The capacitive sensor only allows touch from conducting objects such as a finger.

The device is culnerable to outside stimuli such as water.

Other electronic devices that are closeby might influence the measurement results.

3.4 Thermochromism

3.4.1 Thermochromism

Thermochromic materials are pigments in powder state that change color when heated up. This powder can be mixed with a liquid material to apply it as a paint. There are two variants within thermochromic materials: Liquid crystals and leuco dyes. The changing temperature of liquid crystals can be very accurately determined, but only two different colors can be created in the spectrum. Leuco dyes can contain a wider range of colors, but it is difficult to determine the exact temperatures where color change occurs.

3.4.2 Changing color

Thermochromic pigments usually consist of multiple components. (White & LeBlanc, 1999) The color former itself, a color developer and a co-solvent. This color former can be a leuco dye which reacts with the color developer, and together determine the wavelength of the emitted color. At low temperature, the co-solvent is in a solid state, and the colour former mostly reacts with the

color developer. When the temperature rises, the co-solvent melts and the interaction between color developer and co-solvent becomes dominant. The dye does not really interact anymore with the color development, causing the mixture to lose its color. (Aitken et al., 1996)

Temperatures

There are plenty of different thermochromic materials available, with a conversion temperature ranging between -15 and 65 degrees Celsius. Yet, most materials are split into three main categories, namely cold (10°C), body-heat activated (31°C) and warm (43°C). (Kulcar et al, 2010)

Heating element (6)

To produce enough heat, electric energy needs to be transformed to heat, a process which is called joule heating, or resistive heating. A current runs through a material with a high resistance, causing the material to heat up. Excellent materials that can be used for Joule heating are metals such as gold,

silver or copper. These metals have a high melting temperature, high resistance, and low temperature coefficient of resistance (the resistance of the material will not decrease much as temperature of the material rises).



Figure 3.12: Thermochromic tattoo

3.5 Technical analysis (thermochromism)

3.5.1 Materials

Thermochromic paint

Leuco dyes
Liquid crystals

Substrate

Ecoflex (silicone-rubber)
PDMS
PVC film
PU film
tattoo paper

Stretchable conductors

Carbon filled PDMS (cPDMS) (Lu et al., 2014)
EGaIn (Lu et al., 2014)
PEDOT:PSS (Lu et al., 2014)
Carbon nanotubes PDMS (Cao & Rogers, 2009)
Graphene (Kim et al., 2009)
Hydrogels (Yang et al., 2016)

Heating element

Silver (AgNW) filled PDMS (Lu et al., 2014)
Conductive wire (Wang et al, 2017)
Gold leaf (Kao et al, 2016)

3.5.2 Parameters

Voltage
Current
Thickness
Surface size
Usage time
color
Switch temperature
Shape

3.5.3 Screenprinting

Painting
drop casting

3.5.4 Limitations

Scalability
Production time
Usage time
Costs
Safety concerns
Changing speed

3.5.5 Possibilities

No deformations
Revealing underlying graphics

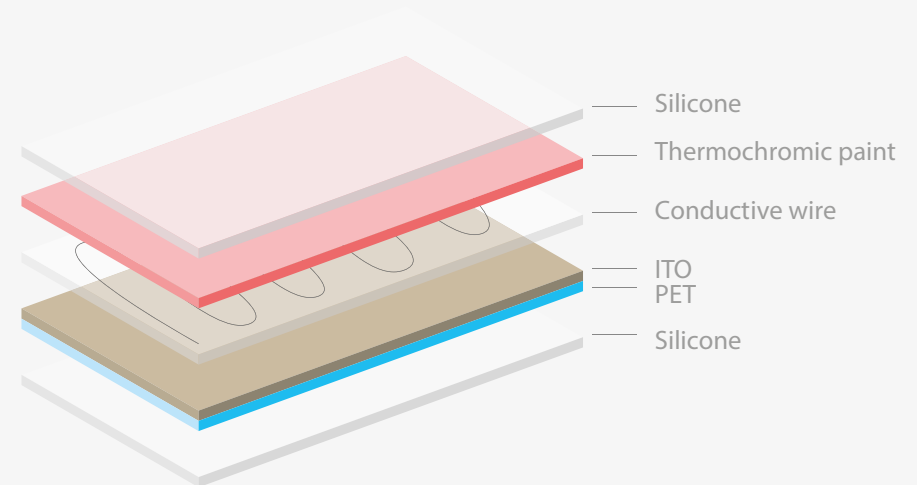

Figure 3.13: Layer build up of thermochromic tattoo

3.6 Mechanochromism

3.6.1 Mechanochromism on the skin

Mechanochromism is a process that allows color change in devices, due to mechanical deformations. Depending on the materials and production techniques that are used, the amount of stretch that needs to be applied to obtain visible color change can differ drastically. In a research paper by Zeng et al. (2016), only 5% stretch is required to see a slight color change, and already with 40% stretch, a full change of color has been reached. A mechanochromic device presented by Kinami, M., Crenshaw, B. R. & Weder, C (2006) showed visual color change between 100 and 500% strain.

3.6.2 Transparency change (as presented by Zeng et al, 2016)

This device consists of two layers. The bottom layer is made of PDMS, which is stretchable and transparent. The top layer is a PVA/laponite composite which is also transparent and contains small cracks. When in undeformed state, the device is completely transparent, when stretched the top layer will open up and its surface will bend and crack a little. (figure 3.17) The little cracks and bending in

the top layer cause the light that falls on it to scatter instead of go through it, which makes the device non-transparent. (Figure 3.14) Wrinkles caused by mechanical stress in polymers cause the polymer to absorb substantially more light compared to a relaxed state of the polymer. (Kim et al, 2012)

3.6.3 Color change (as presented by Zeng et al., 2016)

The color changing device shows similarities to the transparency changing device, as it uses opening of the top layer to change its status. The device is built up out of two layers, both containing PDMS mixed with fluorophores. Fluorophores have the capability to emit light, and this is mixed with PDMS to make it stretchable. Both mixtures emit different colors. One is applied as top layer, making that the main color of the device. The other color is covered under the top layer, and embedded in a uv-shielding material preventing it from emitting light in any direction. (figure 3.17) When the device is stretched the top layer will open up and the underlying layer will become visible. (figure 3.17)

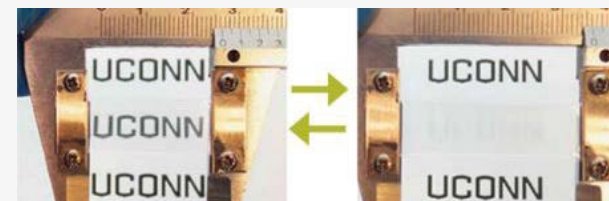

Figure 3.14: Transparency change

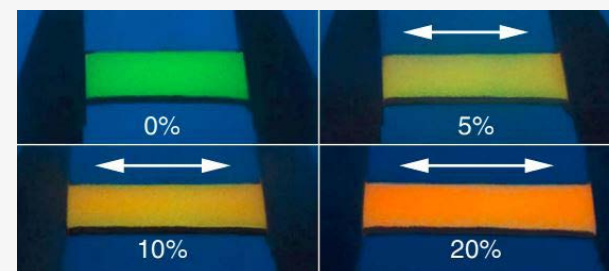

Figure 3.15: Color change



Figure 3.16: Fluorophores in different colors

3.7 Technical analysis (Mechanochromism)

3.7.1 Materials

Fluorophores

- Green: fluorescein
- Red: rhodamine B
- Yellow: rhodamine 6G
- Blue: quinine
- Purple: quinine/rhodamine 6G

UV shielding layer

A mixture of PVA/TiO₂ (Yang, Zhu & Pan, 2004) (1,5 micrometer: Zeng et al, 2016)

Substrate

- Ecoflex (silicone-rubber) (+1mm thickness)
- PDMS (+1mm thickness)

Light scattering layer

PVA/Laponite (5,1 micrometer) (Zeng et al, 2016)

3.7.2 Parameters

- Amount of strain
- Usage time
- Usage cycles
- Color
- Transparency

3.7.3 Processes

- Thin film casting
- Drop casting
- Spray coating
- screen printing

3.7.4 Limitations

- Form complexity
- Decay of fluorophores

3.7.5 Possibilities

- No specialized equipment needed
- High transparency (>88%)
- Large stretch cycle times (>5000)
- Customizability

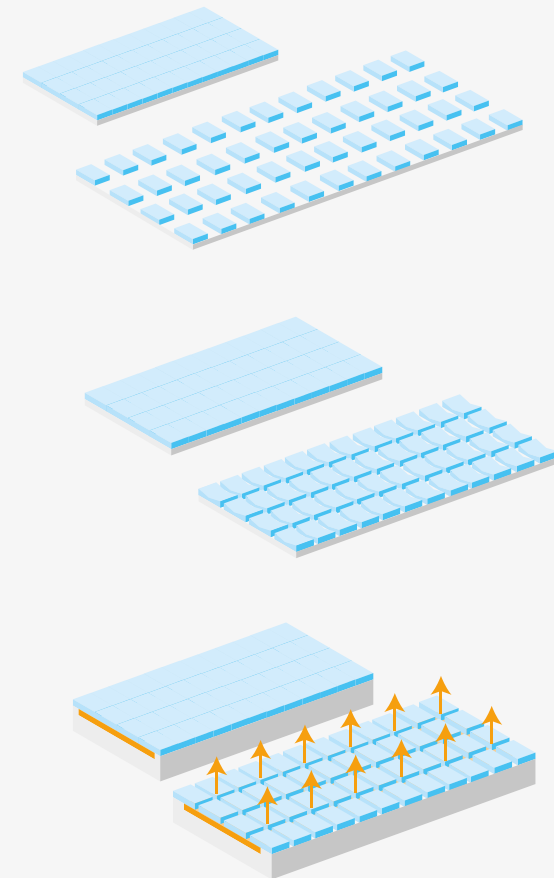

Figure 3.17: Schematic drawing of transparency and color change in the materials

3.8 Electroluminescence

3.8.1 Electroluminescence (EL)

An EL device is a thin material that emits light from its surface. (Figure 3.18) It consists out of multiple layers of different materials that together form this device. In the middle, there is a layer of phosphorus material, which, when activated, emits light. The layer build up can be seen in figure 3.21. The phosphor is activated by an electric field between the two electrodes, which is created by applying an alternating current on the device. A DC-AC inverter is used to power the EL device. This typically generates a AC voltage between 60 and 115 V, at a frequency between 50-1000 Hz. Increasing the frequency result in a brighter light from the EL device. (Dupont, 2012) Although high voltages are used, EL devices are relatively safe, since they use a low current. (Olberding, Wessely, & Steimle, 2014) Often the substrate also functions as an insulating protective layer between electrode and the skin.

3.8.2 Substrate

The substrate is the base layer on which the other layers will be applied. It requires to be insulating:

a high resistivity is typically between 100 ohm/sq (sheet resistance, expressed in ohm/square) and 300ohm/sq (Dupont, 2012), stretchable and preferably transparent (if light emittance from two sides is preferred). A smooth surface of the substrate is important, since it results in more homogeneity of the additional applied layers.

3.8.3 Electrode

Two electrode layers are placed parallel to each other to create an electric field, when AC current is applied. This electrode should be a material that is conductive, stretchable and preferably transparent. Two types of materials can be used as electrode in a stretchable device: A stretchable conductive material, or a stretchable non-conductive material that is mixed with conductive particles. After stretching the electrode the first times, the resistance irreversibly increases, due to small, irreversible cracks that occur in the electrode material. (Lipomi et al., 2012) Applying a lot of stretch results in higher resistance in the electrode, which ultimately results

in a breaking point, where the resistance is too high and the electrode cannot conduct anymore. (Wessely, 2016)

3.8.4 Dielectric

The dielectric is a material which prevents the two electrodes from touching and causing a short circuit. It therefore should have a high resistivity. The thickness of the dielectric is a factor that influences the capacitance of the EL device. ($C = e \cdot A / d$) The thickness of the dielectric should therefore be as thin as possible to reach a higher capacitance and thus more luminance.

3.8.5 Phosphor

The phosphor (powder) material consists of a host and activator. A widely used and available host is zinc sulfide (ZnS). The activator is an additive material that determines the color of the light. The ZnS is a metal containing, inorganic compound and when in liquid form, its electrons can move freely.

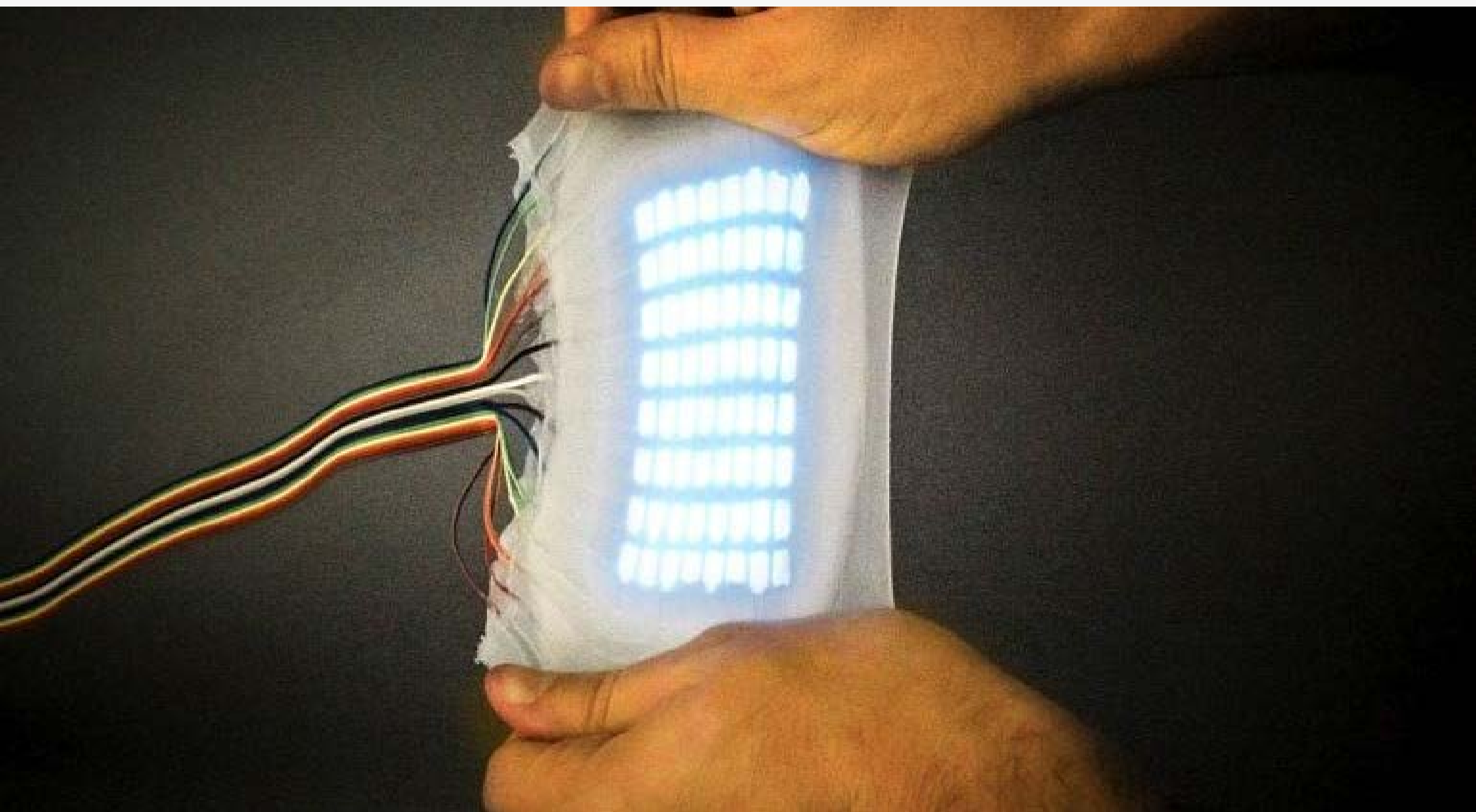

Figure 3.18: a stretchable el device

(physicsopenlab, 2019) These electrons are then captured by the activator. This process releases energy in the form of a photon. (Study.com) The wavelength of this photon depends on what is used as an activating material. The colors will provide a light: this can be in different colors, depending on which phosphor mixture is used. The phosphor layer can be made flexible by mixing the powder with a flexible material, such as silicone.

5.8.6 Coplanar EL device (Xu et al., 2017)

This EL variant is build up out of two stacks both containing one electrode, which are connected through a bridge: which can be a thin film conductor, a conducting liquid or graphite. (Figure 3.19) This device has the same luminance as a conventional EL device. The bridge should be transparent, otherwise the emitted light is not visible.

5.8.7 Matrix (Olberding, Wessely, & Steimle., 2014)

The matrix is a variety on the conventional EL device, that contains rows in one electrode, and columns in the other electrode. The attached micro-controller knows which cross-points of

rows and columns need to light up, and applies a current accordingly. Through quick scanning, these cross-points are lit up, but one by one. This way unintentional lit up of cross points is avoided. This scanning happens so fast, that the human eye perceives it as if all the right cross-points are lit up at the same time.

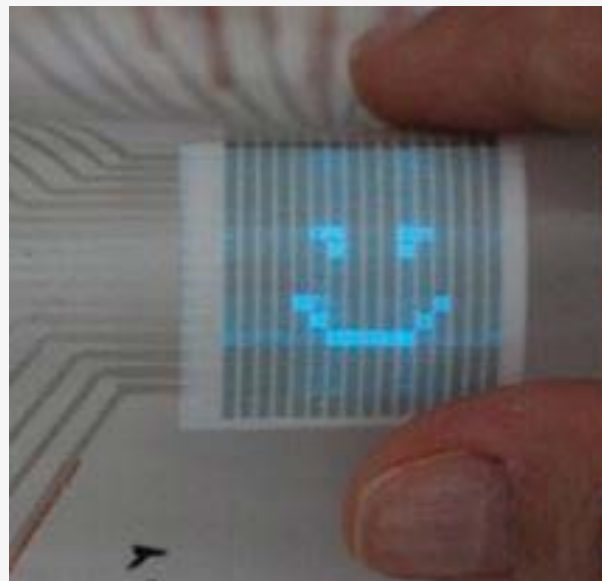

Xu et al., 2017 & Olberding, Wessely, & Steimle, 2014

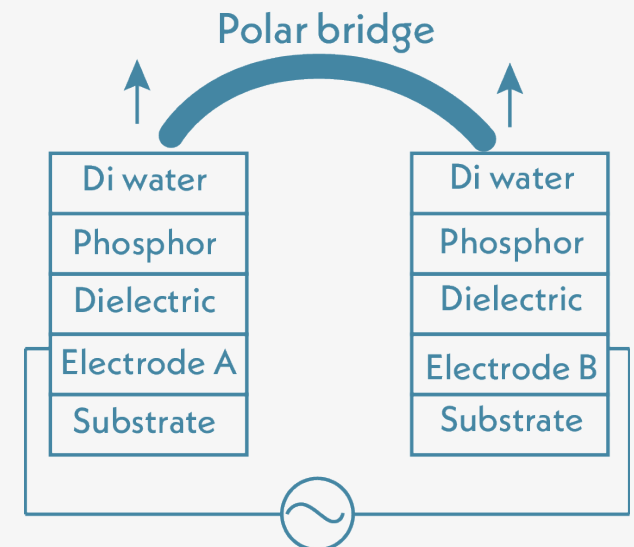

Figure 3.19: schematic view of polar bridged el device

3.9 Technical analysis (Electroluminescence)

3.9.1 Materials

Stretchable conductors

Silver (AgNW) filled PDMS (Lu et al., 2014)
Carbon filled PDMS (cPDMS) (Lu et al., 2014)
EGaIn (Lu et al., 2014)
PEDOT:PSS (Lu et al., 2014)
Carbon nanotubes PDMS (Cao & Rogers, 2009)
Graphene (Kim et al., 2009)
Hydrogels (Yang et al., 2016)

Stretchable substrates and dielectrics

Ecoflex (silicone-rubber)
PDMS
PVC film
PU film
tattoo paper

Phosphors (Yen, Shionoya, & Yamamoto., 2007)

ZnS:CuI (purple)
ZnS:CuCl (blue)
ZnS:CuAl (green)
ZnS:CuMnCl (yellow)
ZnS:Cu (red)

5.9.2 Parameters

Voltage
AC Frequency
Energy efficiency
Capacitance
Surface size
Usage time
Applied strain

5.9.3 Limitations

Decay
Decrease of uniform glow when size increases.
Less luminance compared to conventional light
Price
Breaking point

5.9.4 Possibilities

Uniform surface illumination of complex shapes
Thin, flexible and lightweight
Low power consumption
Very low heat generation
Vibration and impact resistant

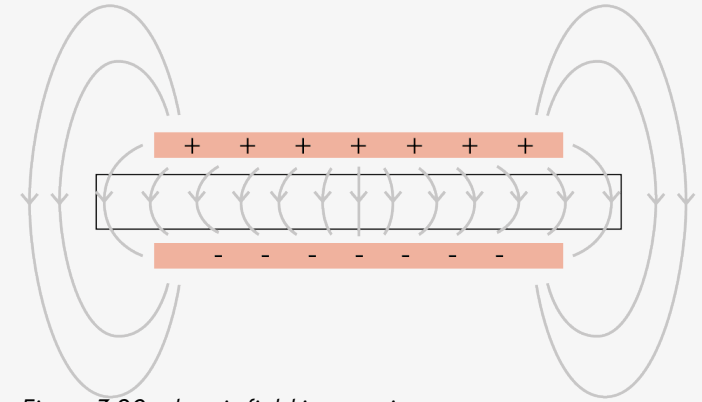

Figure 3.20: electric field in capacitor

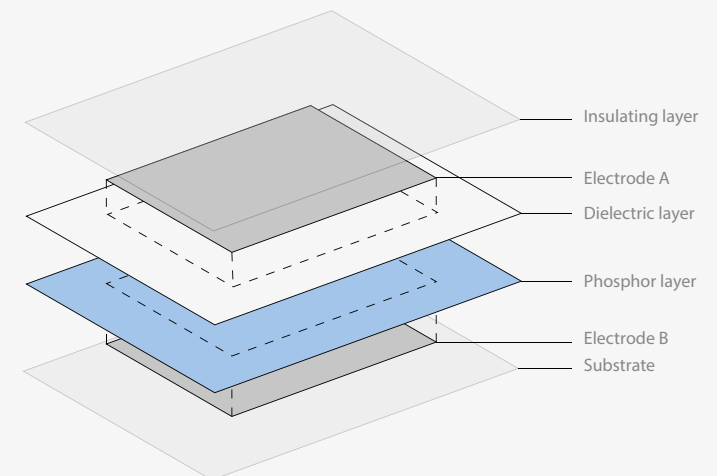

Figure 3.21: Layer build up of el device

3.10 Tactile augmented reality

3.10.1 Tactile AR on the skin

A tactile augmented reality device is a device that sends tactile signals to the user through small electrodes. (Figure 3.22) These signals are sent when the user is touching a product, and simulate a certain tactile sensation with the user. This tactile sensation is perceived as to be part of the product although not actually being there, hence the name augmented reality. Two versions of tactile augmented reality are available. One is presented in the paper Tacttoo (Withana, Groeger and Steimle, 2018), where the user is wearing a tattoo-like device on its skin that is providing the electricity to the skin. In another variant, the electrodes are encapsulated in the product itself, as is presented in for example REVEL (Bau & Poupyrev, 2012).

Depending on the intensity of the signal, this message can be perceived as different kinds of sensations. For example, a low current is perceived as touching sand, while a high current is perceived as touching a sharp object (Withana, Groeger and Steimle, 2018).

To create a realistic and high quality sensation, the location of touch on the body is important. Certain locations contain more nerve density that allows

to feel the difference between certain points. For example, the tip of the finger is capable of sensing the difference between two points when they are separated only 1 or 2 mm from each other. On the forearm, two points need to be apart between 8 and 10 mm to be perceived by the skin as separate points. (Lederman & Klatzky, 2009) To create a realistic experience, the electrode density should ideally match these discrimination values, yet this could cause short circuiting in the device more easily.

3.10.2 Thin device

Placing a tactile AR device on the skin requires the device to be very thin (around 35 micrometer), in order to maintain sensing capabilities of the skin. As tested by Withana, Groeger and Steimle (2018) there is no perceivable difference in acuity when wearing a thin tactile AR device (35 micrometer) compared to clear skin. Yet there is a measurable difference when the user wears a thicker device (100 micrometer) Not losing acuity means the notability of the device is low, which adds to the realistic experience of the tactile AR device.

3.10.3 Small current on the skin

The amount of current that is sent to the skin

through the electrodes determines the tactile experience of the user. The voltage applied to the skin should be below 500V, otherwise the resistance of the skin starts to break down, allowing the current to flow more freely through the body. (Grimnes, 1983) According to the NIOSH (2009), the current that can be applied on the skin at voltages below 500 volt, should be between 1 and 16mA. At 16mA the experience is bearable for only a few seconds. Therefore, the current applied on the skin should never reach near 16 mA. A realistic value in practice to bring across sensations to the user would be when a current between 0,96 and 1,83 mA is used. (Withana, Groeger and Steimle, 2018)

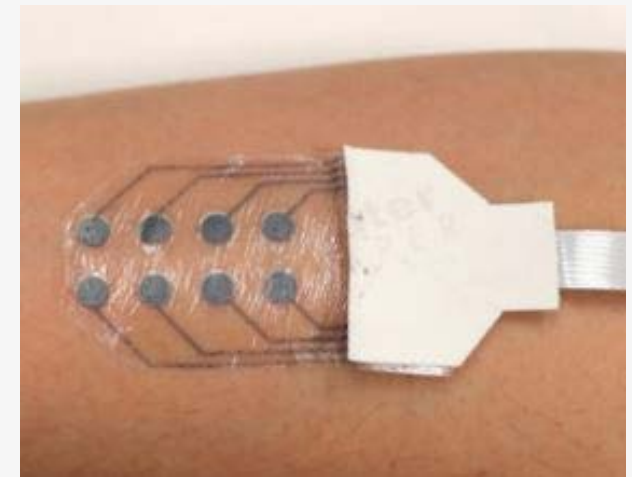

Figure 3.22: Tactile AR device on the skin

3.11 Technical analysis (Tactile AR)

3.11.1 Materials

Substrate

Silicone-rubber
PDMS
PVC film
PU film
tattoo paper

Conducting traces & electrode

Silver (AgNW) filled PDMS (Lu et al., 2014)
Carbon filled PDMS (cPDMS) (Lu et al., 2014)
EGaIn (Lu et al., 2014)
PEDOT:PSS (Lu et al., 2014)
Carbon nanotubes PDMS (Cao & Rogers, 2009)

Insulator layer

Binder
Silicone rubber
Insulating spray

3.11.2 Parameters

Current
Frequency
Thickness
Usage time
Surface size
Electrode density
Electrode size

3.11.3 Limitations

Form complexity
Safety concerns
Scale
Deformations
Short circuiting
Sensitive to water

3.11.4 Possibilities

Feel through experience
Dynamic orientation landmarks on the skin
Sticks to the skin

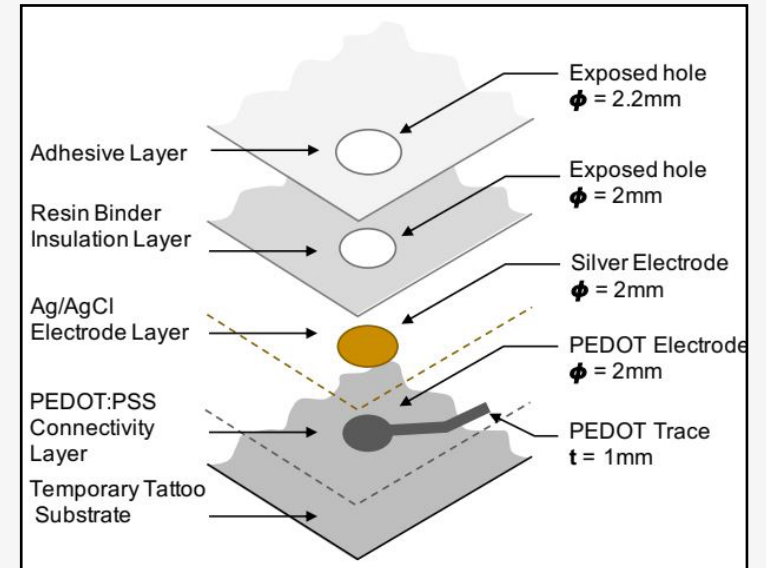

Figure 3.23: Layer build up of tactile device

3.12 Shape memory materials

3.12.1 SMA's

In the paper of Hamdan et al., (2019) the device Springlets (figure 3.24) is presented. This is a shape memory alloy (SMA) based patch that can be placed on the skin to provide tactile feedback to the user. SMM's (shape memory material) are materials that are capable of changing shape when circumstances change. As a result, SMM actuators provide an excellent technological opportunity to replace conventional actuators. (Hartl & Lagoudas, 2007) Two important SMM's are the SMA and the SMP (Shape memory polymer).

3.12.2 The SMA (heat responsive)

The SMA exists in a one-way form and a two way form. (figure 3.25) The one way form can memorize one state: the Austenite state. When the SMA is cold it can be deformed, and it will return to the Austenite state when heated.

The two-way SMA also can memorize the Martensite state, which reverts the effect (Buehler, Gilfrich, & Wiley, 1963). The SMA starts transitioning to the Martensite state when the temperature decreases. A common way to train the SMA (creating the memory) is described by Guide (2004) and involves heating the SMA on a certain temperature for 10 to 25 minutes, when it is in a fixed position, and afterwards cooling down the SMA quickly. A helical spring is the most popular SMA shape for an actuator because it can produce the most displacement. (Jani et al., 2014) Another shape the

SMA can assume the form of a thin film: SMMs are deposited directly onto micro-machined materials or as stand-alone thin films to become micro-actuators. (winzek et al., 2004) NiTi is a much preferred alloy, due to the attributes as high actuation force, displacement, (Kahny, Huffz, & Heuer, 1998) stability and practicability. (Wilkes, Liaw, & Wilkes, 2000)

The SMA (responsive to magnetic field) - The MSMA (magnetic SMA) receives energy through a magnetic field instead of heat, which results in relatively fast actuation, up to 1kHz. (Tellinen et al., 2002) Unfortunately, MSMA's are very brittle and stiff. (Czimmek, 2004)

3.12.3 The SMP

In general, SMPs are formed by two active phases. One is the fixity phase and the other one acts as the 'switch phase'. In the fixity phase the shape changes to its memorized form, and in the switch phase the temporary form can be adjusted. SMP's respond to heat, which can be generated through different ways:

The SMP (electric field responsive) - The SMP is mixed with fillers (such as carbon nanotubes) which can transform the electric energy into thermal energy when they are immersed in an electric field (Liu et al., 2009)



Figure 3.24: SMA on the skin

The SMP (magnetic field responsive) - The SMP is mixed with magnetic nanofillers which are super-paramagnetic and they produce heat when they are immersed in a magnetic field. (Mohr et al., 2006)

The SMP (light responsive) - The SMP is mixed with carbon nanotubes, which enhance thermal conductivity. An infrared light causes heat and the SMP will return to its fixed state. (Wong, & Venktraman, 2010)

3.12.4 Conclusion

SMPs are claimed to be a superior alternative to SMAs. It is more energy efficient, cheap and operates at lower temperatures. (Voit et al., 2010) A drawback is its slow actuation response (1Hz), and low stiffness, although this could be overcome by adding reinforcements to increase the stiffness. (Gopi et al.) SMAs based on heat are still preferred for applications that require higher actuation forces and faster response, (Jani et al., 2014) and are preferred in an helical shape or thin film. Based on the desired application, a decision can be made between the SMA and SMP, and the preferred activation type of the SMP.

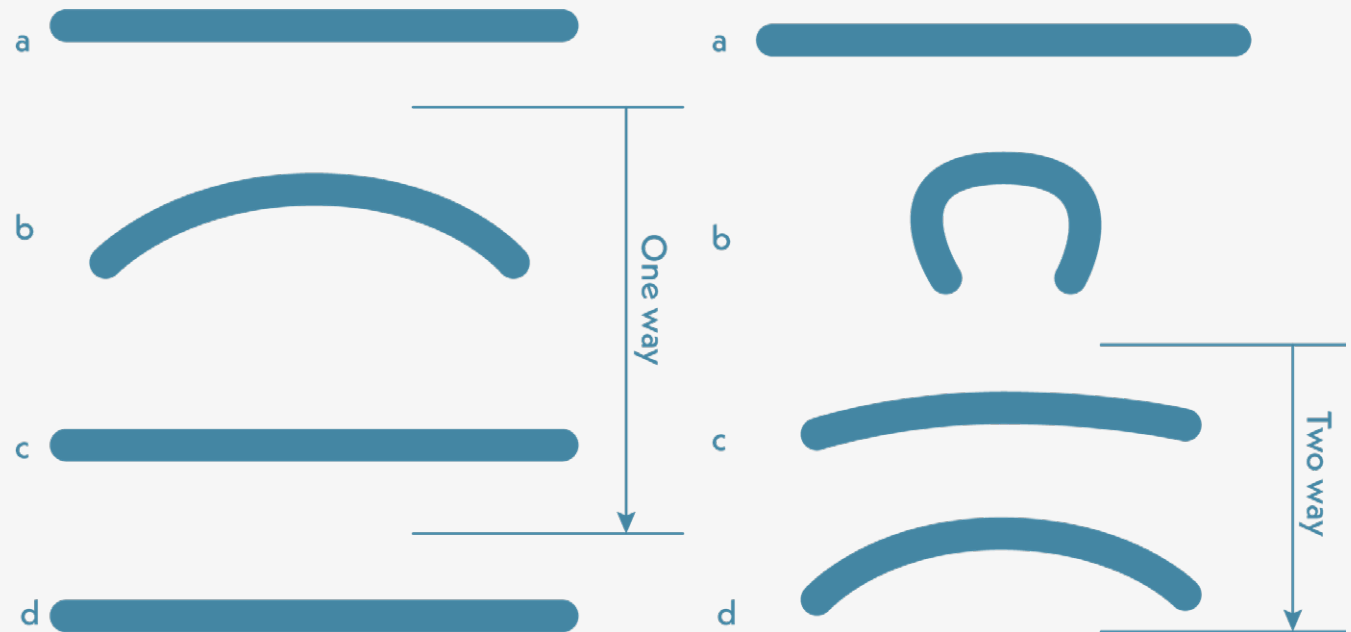

Figure 3.25: One way and two way SMA

3.13 Technical analysis (SMM)

3.13.1 Materials

SMA alloys (Kohl, 2010)

NiTi based
Cu based
Fe based
Ag based
Au based
Co based

SMP polymers (Liu & Qin, 2007)

PTFE
PU
Poly-caprolactone
EVA + nitrile rubber
PET-PEG

3.13.2 Parameters

Operating temperature (Ochonski, 2010)
Operating speed (Ochonski, 2010)
Cost (Ochonski, 2010)
Deformation force (Ochonski, 2010)
Energy efficiency (Ochonski, 2010)

3.13.3 Processes

NiTi production (Karamichailidou, 2016)

Vacuum Induction Melting (VIM)
Vacuum Arc Melting (VAM)
Electron Beam Melting (EBM)

Self propagating High temperature Synthesis (SHS)
Conventional Sintering (CS)
Metal or Powder Injection Molding (MIM)
Space Holder Technique (SHT)
Hot Isostatic Pressing (HIP)
Spark Plasma Sintering (SPS)
Laser Sintering (SLS)
Selective Laser Melting (SLM)
Laser Engineered Net Shaping (LENS)
Electron Beam Melting (EBM)

Training (Karamichailidou, 2016)

Shape setting
Shape memory training
Stress-induced martensitic transformation training
Thermal cycle training under constant load
Over-deformation training

3.13.4 Disadvantages SMA on the skin

Safety concerns due to high temperature (Hamdan et al., 2019)
Low recovery speed (Jani et al., 2014)
Low energy efficiency (Jani et al., 2014)
Low accuracy (Jani et al., 2014)

3.13.5 Advantages SMA on the skin

Stronger actuation force (Hartl, & Lagoudas, 2007)

Can memorize two shapes (Buehler, Gilfrich, & Wiley, 1963)

3.13.6 Disadvantages SMP on the skin

Low recovery speed (between 1 sec and several minutes) (Ochonski, 2010)
Low stiffness (its shape is easily deformed by force) (Gopi et al.)

3.13.7 Advantages SMP on the skin

Relatively low temperature (Less harm to the skin) (Gopi et al.)
Cheap material (Ochonski, 2010)
Easy shape training process (Ochonski, 2010)
Is energy efficient (Gopi et al.)
Recovery precision of over 99% (Lendlein, & Kelch, 2002)

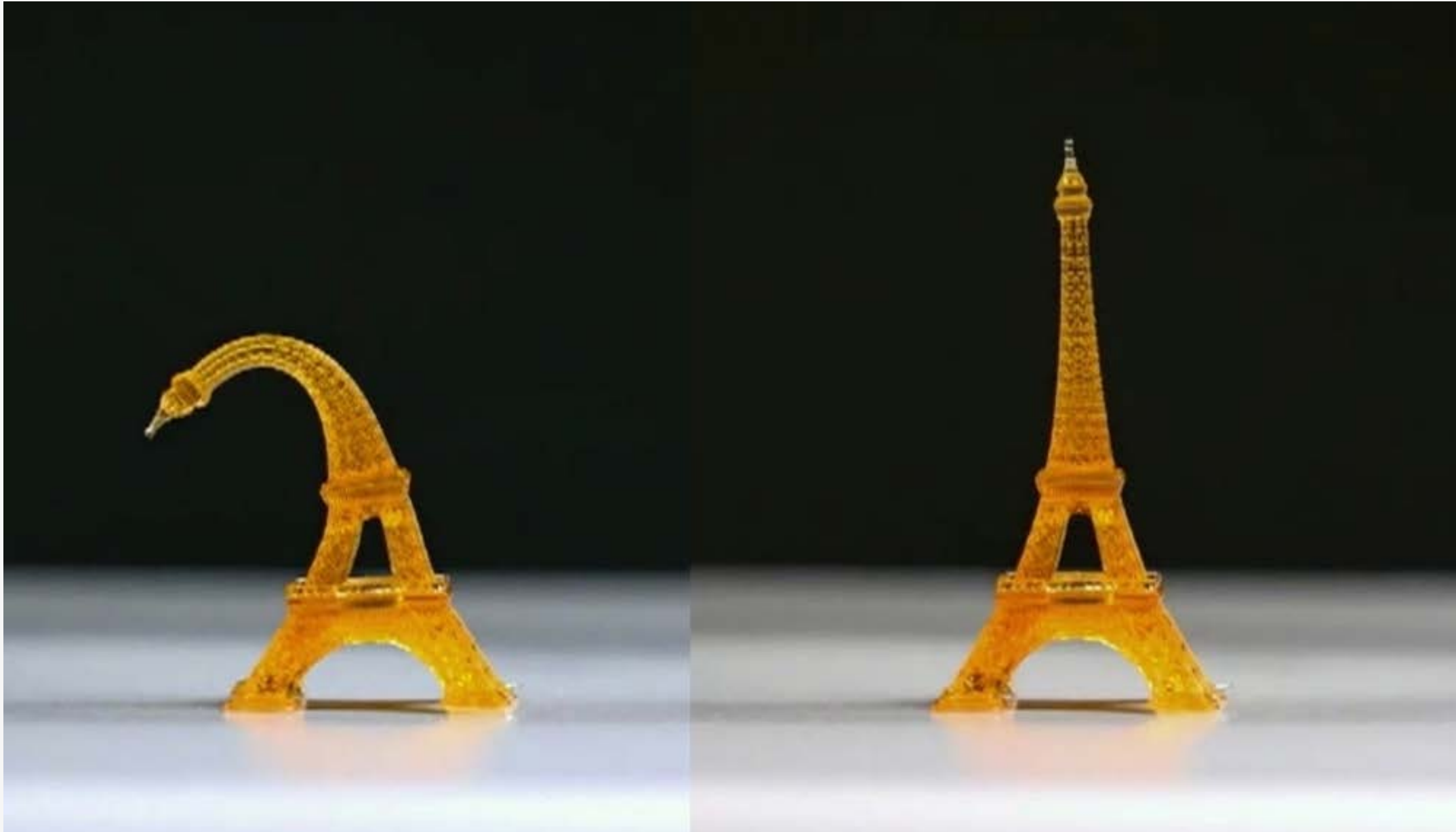

Figure 3.26: Example of shape memory polymer in use

3.14 Production of an interface on the skin

3.14.1 Screen printing

The most common and accessible way to create thin interfaces is through screen-printing. Screen printing is a production process that uses a mesh and a doctor blade to apply multiple, thin layers of material on top of each other. As a base layer, a substrate is placed under the mesh. A vinyl stencil is applied on top of the mesh, and the material is pressed through the mesh only at places which are not covered by the stencil, using the doctor blade. Through this method, a thin layer of material can be applied on top of a substrate. After applying each layer, the layer needs to be dried, which is called curing. Curing can either be done by using an oven, an air blower or by just waiting, depending on the material that has been applied. Screen printing has as advantages that it allows for inexpensive and fast prototyping at a low volume. (Olberding, Wessely, & Steimle, 2014)

3.14.2 Production time

Using this method, it will take around 1 or 2 hours to create a thin device. This time is mostly used as curing time, since every layer requires time in the oven to cure and dry. This time could possibly be diminished, as, for example, is shown by Randy Wajwakana in his master thesis (2017). In this thesis an electroluminescent device is created using a mixture of phosphor and UV-resin. With this method, the phosphor layer only requires to be put under an UV-lamp for 1 or 2 minutes, which results in a total production time of only 10 to 15 minutes.

3.14.3 Improving through experimenting

Through iterative experimenting with different materials and production methods, more tools could be used to improve the production quality and speed of the interface creation. Promising developments involve laser-cutting of the interface, which allows for more complex forms and is a faster and more accurate way compared to vinyl cutting. Another interesting development is the use of insulation spray as dielectric. Using this spray to develop the interface decreases the drying time drastically, and results in less errors. Where it is common to use materials such as BaTiO_3 as dielectric, errors occur easily due to small holes in the layer causing the electrode layers to connect. Using a silicone spray results in more homogeneous surfaces.





3.15 Working in the chemical lab

3.15.1 Goal

To get more familiar with thin materials that can be applied on the skin, time was spent in the chemical lab at the TU Delft.

The main goal was to make a device that would be applicable on the skin, using the facilities available at the applied labs at the IDE faculty. To give this device more purpose, its goal would be to emit electroluminescent light.

3.15.2 Finding the right materials

Through trial and error, the right materials had to be found to produce an electroluminescent display on the skin.

3.15.3 Screen-printing

As a result of working in the chemical lab, more experience was gained on the method of screen-printing. How to work with the materials in screen-printing is important, since there are many factors in this process that can cause faults in the device.

3.15.4 Results

During the sessions I managed to make thin, working electroluminescent devices. In figure 3.28, an electroluminescent device is visible that is printed on tattoo paper. Continuing this process would lead to more homogeneous luminance of the light, and a device that is more resistant to damage when bending.

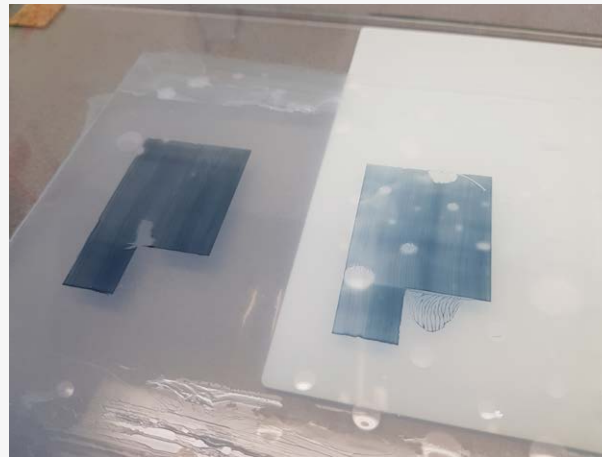
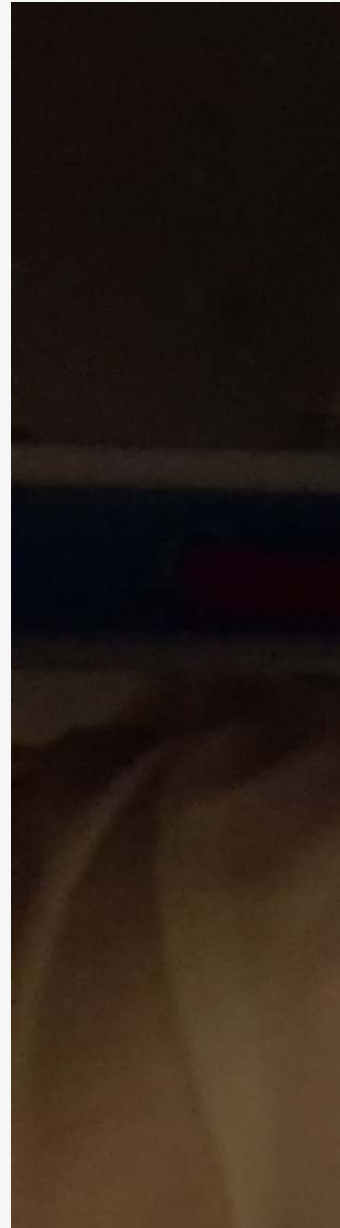
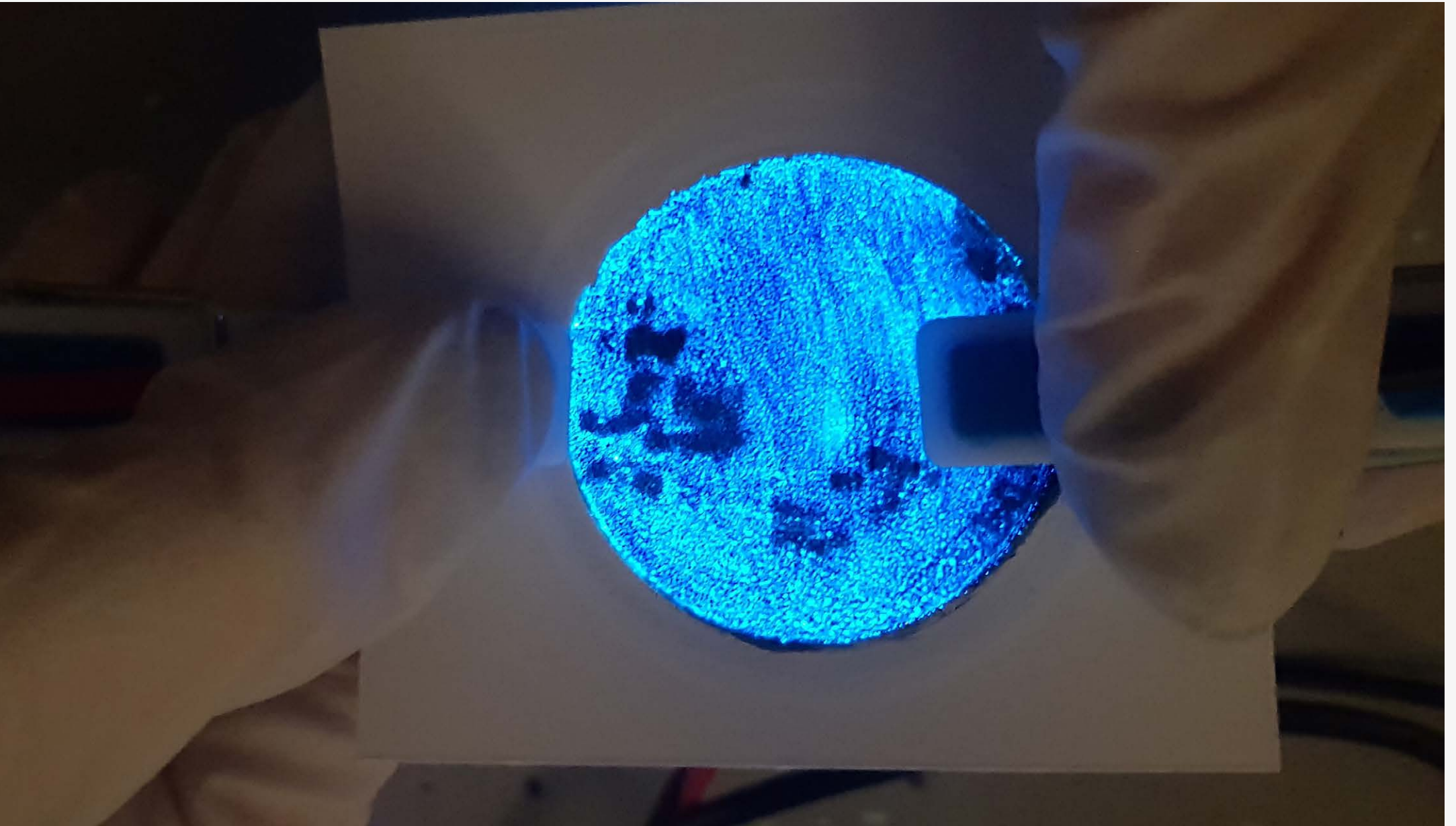

Figure 3.27: PEDOT screenprinted on a layer of silicone-rubber





3.16 Conclusion Exploring context & direction

3.16.1 Progress

Societal analysis

This exploring context and direction phase started off with the societal analysis in which the design goal and domain of design have been converged. This is done with the VIP method as a guidance. With this converged goal and domain, a design analogy was created: an analogy interaction that helps articulating how the interaction between user and to-be designed product should be.

Personal analysis

This analogy was analyzed and resulted in two key design factors which were analyzed in the next phase: the personal analysis. The two key factors that were analyzed were user adaptation and habit change.

Technical analysis

The last part of the exploring context and direction phase involved the more technical aspects of the potentially used materials. This part is meant to be used to provide better understanding of possibilities and limitations during further ideation within the process.

3.16.2 Results

Societal analysis

Using the VIP method, a new design goal was created: reducing the amount of negative technological impulses through the creation of awareness. The domain has been converged to the following sub-topic: The overwhelming effect of the stimuli received by technology. The design analogy that was created with this new design goal and domain is: The product should be interacted with as one interacts with their personal coach at the gym. It should be motivational, conscious, constructive and realistic.

Personal analysis

Further analysis of this analogy resulted in two important key design factors: user adaptation and persuasive design. User adaptation states 6 factors that determine user adaptation:

- Functional needs
- Cognitive attitude
- Social aspects
- Physical aspects
- Demographic characteristics
- Technical experience

Persuasive design consists of two important factors (motivation & ability), which when both present, require a trigger to enable habit change.

Technical analysis

In this sub-chapter, several predetermined materials and sensing techniques have been investigated and this resulted in more understanding of their workings, together with a list of their advantages and disadvantages.

3.16.3 Following steps

The research done during the exploring context and direction phase can help during different stages of the design process. The new design goal and domain can be used as a guideline for the rest of the project.

During the exploring context and direction phase, the material analysis will be used to generate the first ideas. Doing research on the different materials helps with estimating the feasibility of these ideas.

Further on during the design process, the insights gained in the personal analysis come in helpful for further development of the concept.

During the whole design process, the design analogy can be consulted to test whether the idea is still moving into the right direction.

The next phase of the design process will be the exploring solution space. Here, the concept will take its first steps towards becoming more concrete.



Phase: Exploring solution space

4.0 Introduction exploring solution space

In this chapter, the solution space is explored and discussed in the sub-chapters, *Generating ideas*, *Clustering the Ideas*, *How do we use our time on the phone?*, *Target Group*, *Exploration of awareness of relationship*, and finally *Connecting to others through unexpected interactions*. An initial concept is built on the findings of this chapter.

4.1 Generating ideas

To find the possibilities that an interface on the skin could offer, the five actuators were all explored. What can you do with them, what could their function be or how could it assist someone to become 'more aware'?. How and where on the body could the different techniques be applied, and what different technical stimuli could they combat? On the right, a grasp of the exploring sketches can be seen, to give an impression of the directions. All ideas were generated within the context of reducing technical stimuli, or creating more awareness around technical stimuli for the user. From here, already some interesting ideas were developed: People could maybe get in touch with each other through tactile interactions over a distance, or could use the interface on the skin to bring groups together and have more real-life contact. All ideas were put together and, through clustering, provided some interesting general idea directions.





A necklace that senses when you look down (to your phone)

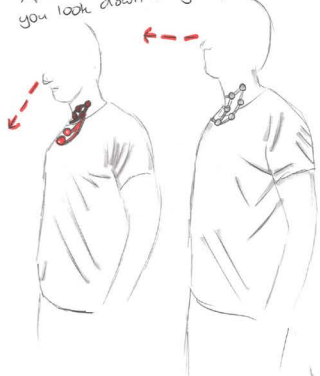

Shirt shows how many times phone has been grabbed



Color change on the shoe makes you aware that you are looking down (to your phone)



A message can be revealed on the body



You decide how frequent you receive notifications



SMA mimics a breathing pattern to help relax



Be more relaxed using SMA

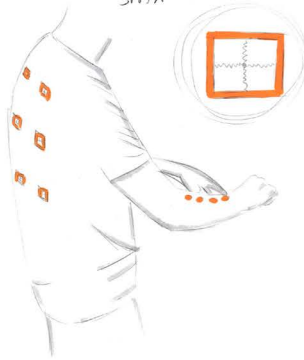

A shirt that shows how active you've been lately



A graphic that grows when you don't use your phone



Clothes that change color at places of inactivity

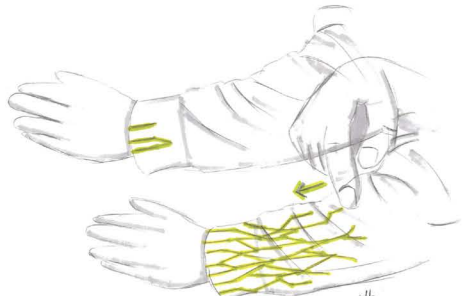

Visuals that decrease with phone use and have to be placed back manually

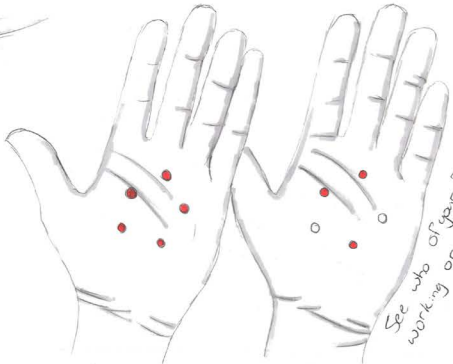

See who of your friends is working or distracted

Color of the shirt changes when kids play



Shirt that senses where light comes from



A color changing bar that helps you remind it is working time now



4.2 Clustering the ideas

Next, all these ideas were clustered. Interesting was that some ideas were addressing and evoking awareness in the user in a different way compared to others. It became clear that awareness to reduce stimuli could come in different shapes. A device that makes you feel more connected to your environment provides a different type of awareness to the user compared to a device that connects people. Awareness can both be restrictive of the negative and enhancing of the positive. If only attention is paid to awareness of negative habits, the area or search stays limited. If awareness of the positive is also considered, the amount of different search areas grows. All ideas could be roughly divided over five different types of awareness.

4.2.1 Awareness of location

A device that allows you to be more aware of, and enjoying the moment. Something that makes you more aware of where you are and enjoy the moment more.

4.2.2 Awareness of time

Ideas that make you think of what you are currently spending your time on. The thought behind this category is that the interface on the skin can be used to make people think about how they would like to spend their time.

4.2.3 Awareness of function

These ideas put more emphasis on function. People are often grabbing the phone for one function and get distracted by others. By isolating one specific function, distraction can be avoided.

4.2.4 Awareness of relationship

Creating more awareness on current or new relationships in real life, diminish the need for social experiences through the phone or computer, such as social media.

4.2.5 Awareness of a purpose

More awareness of a goal and of reasons for doing things should result in less distraction and more determination. It reminds and evokes motivation to focus on your current tasks, and not on less important activities.

4.2.6 Direction

The direction that I chose is awareness of relationship. To decide whether this is the right direction to go with, I looked into the most commonly used technical devices, and which have the most impact on our lives. Putting the emphasis of awareness on this specific part could potentially have the biggest impact.

From all technical devices people use during the day, the phone is by far used most frequently (figure 4.1). Besides this frequency, these uses are also spread out over the whole day (figure 4.2), making the phone the most present technical device in our daily lives. Given the high frequency it can easily be concluded that the phone is interrupting our daily tasks, but what do we do on our phones?

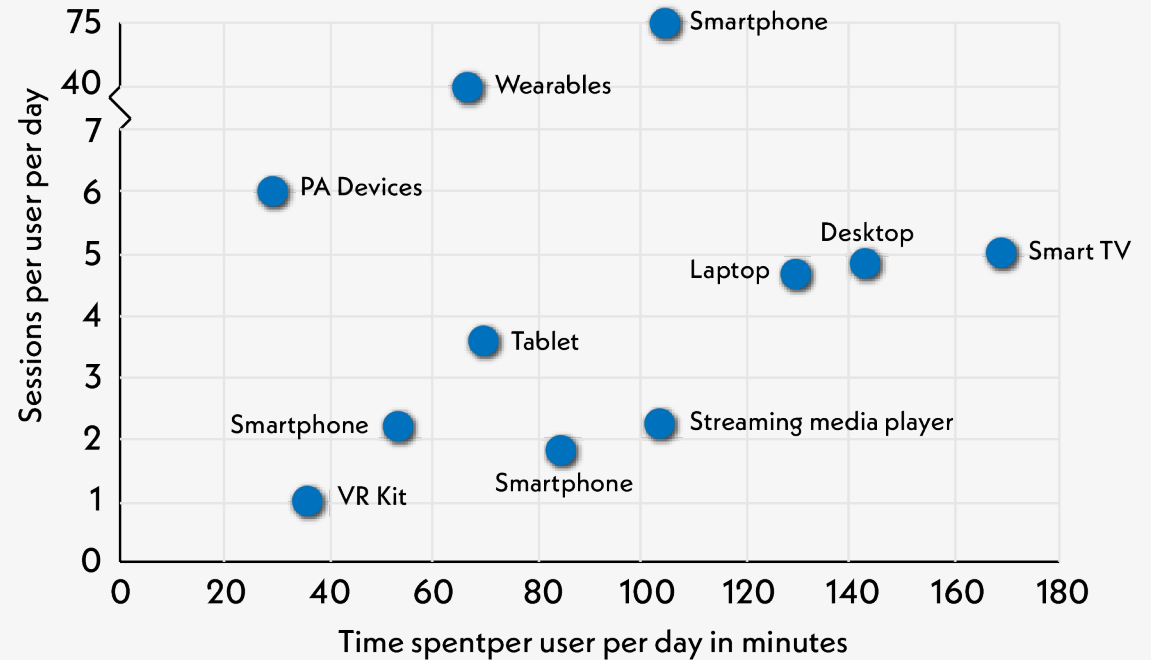

Figure 4.1: Schematic view of amount of sessions and time spend on different technologies
<https://www.vertoanalytics.com/chart-of-the-week-which-devices-are-used-most-often/>

Devision of phone sessions of an average user

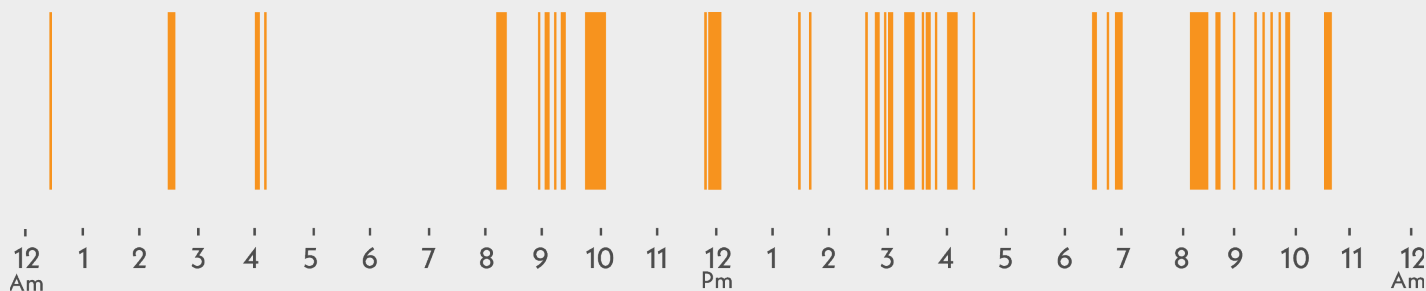

Figure 4.2: Devision of phone sessions over the day
<https://blog.dscout.com/mobile-touches>

4.3 How do we use our time on the phone?

When we look at what we do on the phone, it becomes clear that social media/messaging are by far the most time consuming (figure 4.3). Social media and social interaction through the phone are mainly addictive because of the instinct of people to constantly search for social interaction, which we are able to receive infinitely through our phones. To decrease this social need, more emphasis could be put on real life interactions, and on creating more awareness of relationships that people already possess, or possibly could create in social situations.

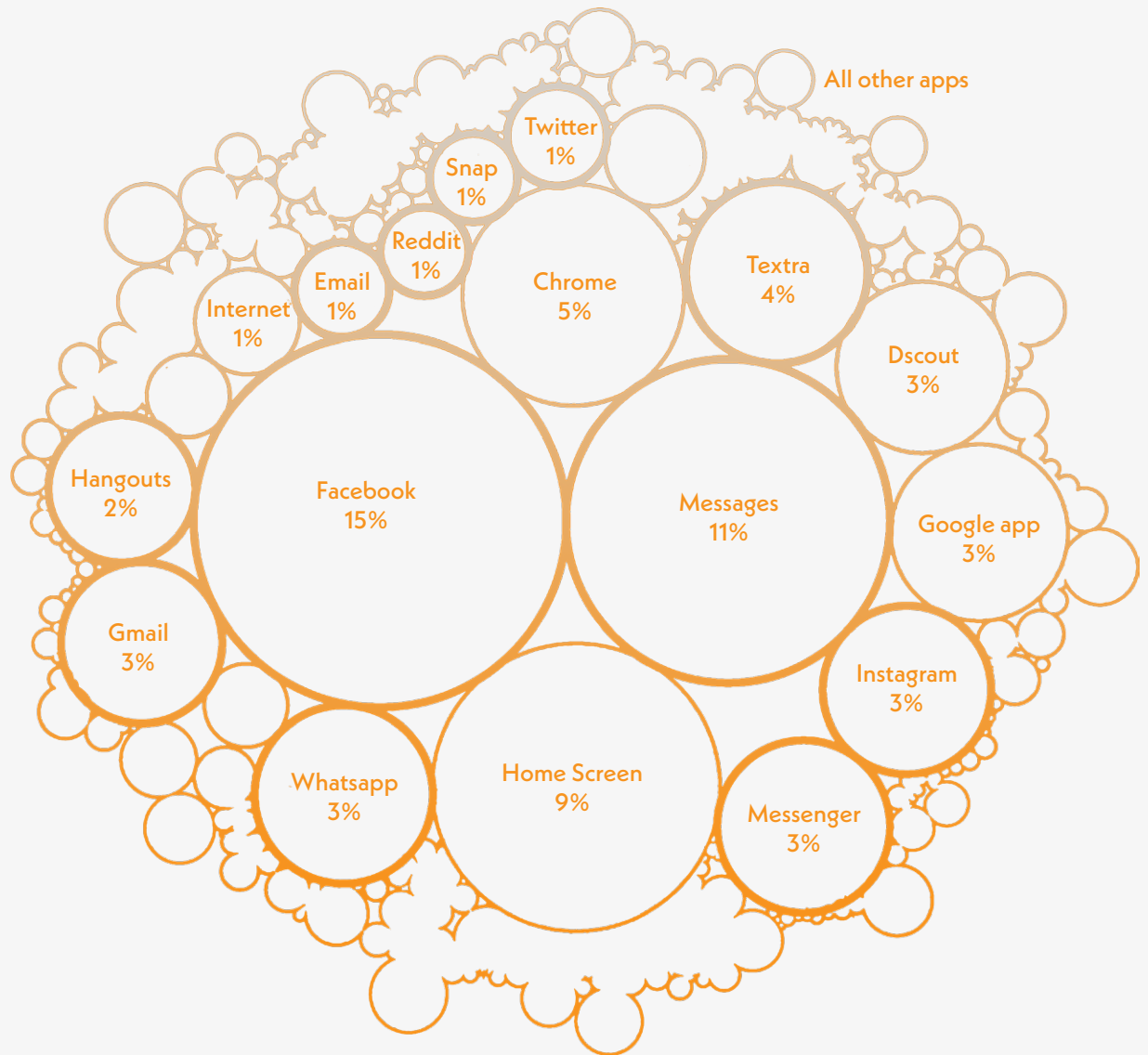

Figure 4.3: What people spend their phone time on, expressed in percentages (From: <https://blog.dscout.com/mobile-touches>)

4.4 Target group

The group that is most affected by smartphone use, and shows most symptoms of addiction, is the age group of adolescents between 20 and 34 years old. (Csibi, Griffiths, Demetrovics, & Szabo, 2019) In figure 4.4, different age groups are compared on levels of addiction. These levels are expressed in the SABAS: Smartphone application-based addiction scale. This scale is based on 6 characteristics that describe addiction (Griffiths, 2005) The age group 20-34 scores particularly high on salience, which is defined by how preoccupied we are with the smartphone. This makes sense, since social life, travel, and job-seeking is relatively typical in this age group, the highest level of salience may not necessary reflect addiction, although it clearly shows that this age group is highly dependent on their smartphone (Long et al., 2016)

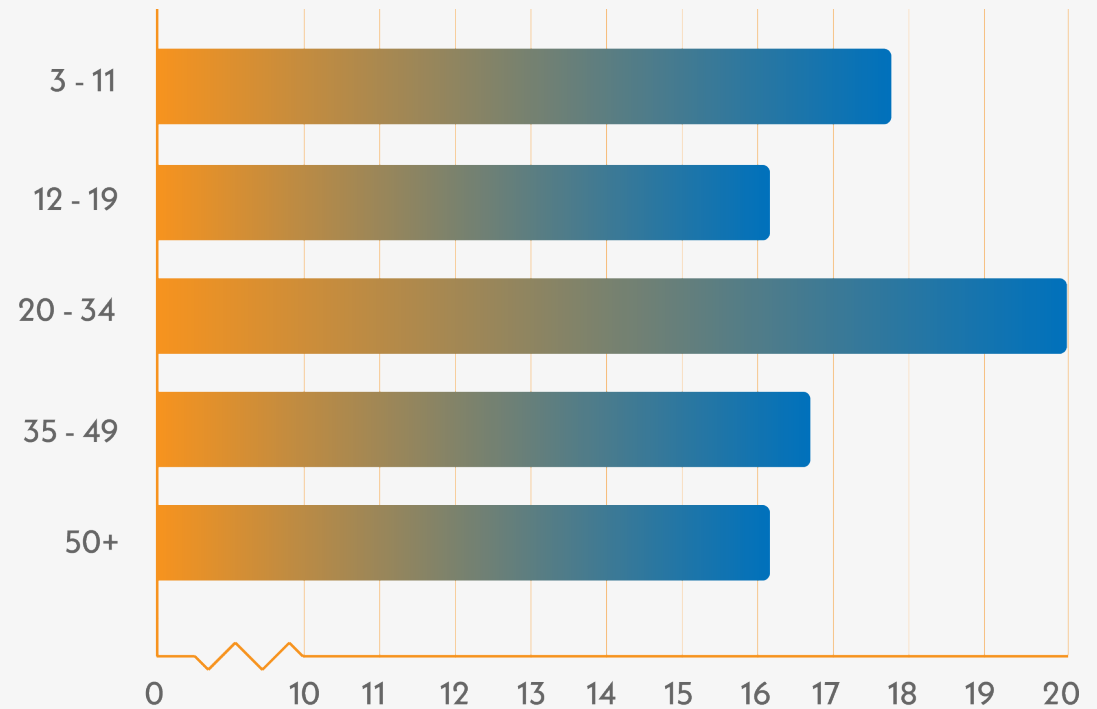

Figure 4.4: The SABAS score per age-group (Csibi, Griffiths, Demetrovics, & Szabo, 2019)

4.5 Exploration of awareness of relationship

4.5.1 The goal

To explore the topic of awareness of relationship, a creative session has been conducted. In this session, people were asked to reflect on their own lives and interactions and relations that they have. Why do people feel the need to get more social interactions through technology instead of through real life interactions with the people around them? A few exercises helped the participants to get more familiar with the topic and helped them to express their opinions. In this chapter some interesting and helpful insights are shared which resulted in a further specification of the design direction within the topic of creating more awareness of relationship.

4.5.2 Enjoyment of real life interaction

What do people enjoy about their real life interactions, when they are compared to the interactions that are gained through technological devices? What was mentioned the most here were interactions that are difficult to receive and provide through technology.

Physicality in the interaction

One major enjoyment of real interactions was the physical aspect of it. Hugs and kisses add a new layer to the interaction, but even a small touch on the arm is already something that makes the interaction so much more valuable compared to an interaction through the phone.

Expressing yourself

Something else that is difficult through technological communication is expressing yourself. When people communicate, they do this partially with non-spoken messages expressed by the body. Technology is a big barrier in this, since it is difficult to express feelings through a text message.

Technology lacks randomness

Technology also lacks the random interesting conversations people sometimes have with others. Conversations through technology most of the time serve a purpose and if not, they often lack profundity. Real life conversations can occur everywhere and with everyone about anything, and conversations through technology are mostly with a predefined topic with a specific person from your contact list.

Real life interactions can contain more than the communication alone

Interactions of people in real life can contain much more than just the communicational part. People can do all sorts of activities while interacting, making the general experience much more complete and valuable compared to an interaction through the phone. You create shared experiences with others which results in much stronger connections to the people you interact with.



Figure 4.5: Different creative sessions

“I like to show my appreciation through hugs and kisses”

“Sometimes I still check my phone even if I didn’t receive a notification”

4.5.3 Connection to others

There are quite some reasons why people connect to others. These reasons partially determine the type of connection and interactions between people, but fully determine whether people have a reason to elaborate on a first contact or decide to neglect the relationship. A first contact is often based on shallow motivations or no motivations for contact at all. A first contact could be made out of curiosity or interest for the other person, but mostly occurs at random. (Bumping into someone in the metro can already be a reason to spark a conversation) The lack of randomness online explains why people make much less new connections through technology, and it also explains the popularity of apps such as Tinder: they bring back the randomness that is often needed to meet and interact with new people. Maintaining relationships with people often requires more meaningful reasons.

Having things in common, things you can do together.

One of the drivers of maintaining relationships is having shared interests. Shared interests provides you with activities to do together, and topics to talk about with others. In this, the topic often does not even matter, it is about doing things together and sharing experiences.

Helping each other

Another reason for maintaining relationships is benefiting from each other. The relationship between people can grow, since the benefit that each side gains keeps bringing people together and helps growing an emotional connection with the other.

Accepting each other/having shared memories/feelings

A third reason to maintain a connection to someone can be acceptance. With acceptance often comes respect and people become willing to open up more to the other and find courage to share stories they maybe wouldn't share with others. Sharing things with others strengthens a relationship, since it reflects a mutual trust between people.

4.5.5 Clustering

During the session, people answered several questions revolving around their interactions with others. All these answers have been put together and clusters were formed, resulting in the following 5 clusters.

- Benefits of communicating in real life instead of on-line
- Connecting people through unexpected interactions
- Communicating over a long distance, other than through writing or speaking
- Showing appreciation to others
- Connection to people who are not on-line

2.3.6 Connecting to people through unexpected interactions

Within the group, most attention was paid on how to connect people through unexpected interactions which, in my opinion, is a very interesting direction to explore and also fits the design goal. As the search for social interactions is one of the

main drivers of people's extensive phone use, more off-line social contact should result in less need of social apps, and encouraging unexpected interactions is an interesting method for reaching that. Moments of boredom often result in phone usage, but in these moments an unexpected interaction with someone close to you could prevent you from doing so. Often, the only reason for grabbing the phone instead of starting a conversation is convenience. Grabbing the phone is easy and doesn't bother anyone, while a good incentive to start talking to someone random. This lack of reason is creating a threshold which often is too big for most people to cross. Having more unexpected interactions with either familiar people or strangers could reduce the social need that people feel, which is why connecting people through unexpected interactions is an interesting scope within the creation of awareness of real life relationships.

'Connecting people through real life unexpected interactions, to increase the awareness of relationships'

4.6 Connecting to others through unexpected interactions

4.6.1 Brainstorm sessions

To explore the concept of unexpected interactions more thoroughly, and to come to more concrete product ideas, two brainstorm sessions were conducted. The goal was to end with a product idea, that enhances unexpected interactions in an interesting and innovative way, using (one of the) provided techniques.

4.6.2 The context

To come to concrete ideas, external factors such as context should become more concrete as well. As many different contexts were generated where people would like to have more real life interactions, or less on-line interactions. Through discussions, one of those topics was chosen to be explored more thoroughly. In this case, the context that would be explored was the hostel. The hostel is a confined space where people partially come to interact, but where often still a threshold constrains people from connecting to strangers. Yet in this context, connecting with strangers could be very beneficial, since you could find people to spend time or do activities with.

4.6.3 Exploring the context

To find out where and how unexpected interactions could occur or could be most useful, an exploration of the context itself was carried out. All different findings could be clustered and resulted in the following beneficial clusters:

- Finding someone to travel to other places with
- Receiving recommendations from others (where it is nice to eat, work etc.)
- Having someone that initiates activities (Can be group related)
- Learning from others (a new language for example)
- Going to the same hostels with the same people
- Connecting to a local
- Finding people that could help you (Where to buy certain things; where to exchange money etc.)
- Finding people with the same interests, who you can do activities with
- Having more social interaction on itself

All these clusters are reasons to get in touch with others: to cross the threshold and interact. In the follow up exercise the participants were asked to embody a product which could result in one of these interactions/benefits. This embodiment had to be an interface on the skin which made use of touch as an input, and either visual or tactile as an output. From this, some interesting ideas arose.

4.6.4 Back to the essence

What became evident after looking and comparing the ideas, was that they were applicable on multiple contexts. They could work in a hostel, but could also work during introduction week at the university. After looking better at the ideas, it became evident that most of the ideas had the same essentials: either they used an element that was inviting to interact with, or the device was used to communicate with others. Fitting more in the topic of unexpected interactions, would be the prior: a device that invites to be interacted with. What also was noted, was that the special role of the skin was

lost in these interactions: most of the ideas could also be carried out using a wearable, 3d-printed device. To include this element of skin in the concept, it was decided that the device should become tattoo-like. Therefore the concept that will be further developed is:
a tattoo-like interface on the skin that evokes curiosity and invites to be touched, and therefore sparks an unexpected interaction between two people.

“A tattoo-like interface on the skin that evokes curiosity and invites to be touched, and therefore sparks an unexpected interaction between people”

4.7 Conclusion Exploring solution space

4.7.1 Summary and results

This phase started with ideating initial ideas, which were then clustered and resulted in five different types of awareness creation, awareness of:

- Location
- Time
- Function
- Relationship
- Purpose

It is then argued that what people require the most is awareness of relationship. Through a creative session, this topic was further explored, which resulted in five directional clusters revolving awareness of relationship:

- Benefits of communicating in real life instead of online
- Connecting people through unexpected interactions
- Communicating over a long distance, other than through writing or speaking
- Showing appreciation to others
- Connection to people who are not online

The cluster to continue with will be connecting through unexpected interactions, as it is argued that through more unexpected interactions, people feel less need to receive social stimuli through their technical devices.

Through several brainstorm sessions with different people, this cluster and its opportunities have been explored, only to come to the conclusion that the final solution should not be contextual oriented. Yet, it should contain an essence that will be applicable on several different contexts. Therefore, the idea that is decided to continue with is basic in its form, and is stated as:

A tattoo-like interface on the skin that evokes curiosity and invites to be touched, and therefore sparks an unexpected interaction between people.

4.7.2 Next steps

In the following defining solution phase, attention will be given to exploring the possibilities of evoking curiosity of others through a tattoo-like device. This will be done through user-centered methods such as brainstorms and user tests. Throughout the next phase, the device will get more embodiment, which in the end should result in a fully developed concept.



Phase: Defining solution

5.0 Introduction defining solution

5.0.1 Design goal

From the exploring solution space, a new design goal derived: Design a tattoo-like interface on the skin that evokes curiosity and invites to be touched.

Using this new design goal a shift can be made in which materials should be used further on in the design process.

5.0.2 The materials

SMA: Shape memory alloys are suited to initiate (small) movements on the user's skin. Yet there are several reasons why SMA's are not a good fit to continue with given this design brief:

Unlike a tattoo, using an SMA results in a relatively thick device on the skin.

The SMA is more oriented towards the wearer instead of others, and since its relatively small size it is also not noticed as quickly by others as for example electroluminescence.

Mechanochromism: Using mechanochromism on the skin is also not a good fit given this new context. The material changes color or transparency, based on deformation. As a result, the user would have to move to change the material's color. This property is therefore considered to be too limiting within this design goal.

Tactile AR: The tactile augmented reality device also does not fit well with the new design goal. It is mainly oriented towards the wearer, thus not evoking curiosity in others.

Electroluminescence and thermochromism. Both these techniques fit well with the new design goal. They can be produced in a thin device, can evoke curiosity since they are visually interesting, and are not limiting the designer in its possibilities as to the tattoos shape and interaction types. An additional benefit is that both techniques show similarities in their build-up of layers, which makes it easier to possibly combine both techniques.

“Given the new design goal, electroluminescence and thermochromism are considered a good fit to continue with in the next phase of defining solution”

5.1 Explorative user test

5.1.1 Introduction

The tattoo should evoke curiosity and should invite to be touched. Yet it is still unclear how the tattoo can do such things. To find out more about the tattoos capability to evoke curiosity and invite for interaction, an exploitative user test was conducted.

5.1.2 Goal of the user test

The main goal of the user test was to gain insights on four different topics:

How can the tattoo evoke curiosity from others?

How can it be inviting to interact with?

How is being touched by others perceived?

How should the design of the tattoo look like?

This test was meant to uncover peoples opinions on these topics, and to find whether or not some aspects of the interactive tattoo would be universal, disregarding the context it is used in.

5.1.3 Setup of the user test

The user test was performed through conducting separate interviews with 6 different participants, at a confined space at the TU Delft. Every interview was recorded and transcribed afterwards. The user test is a qualitative user test, whereas the

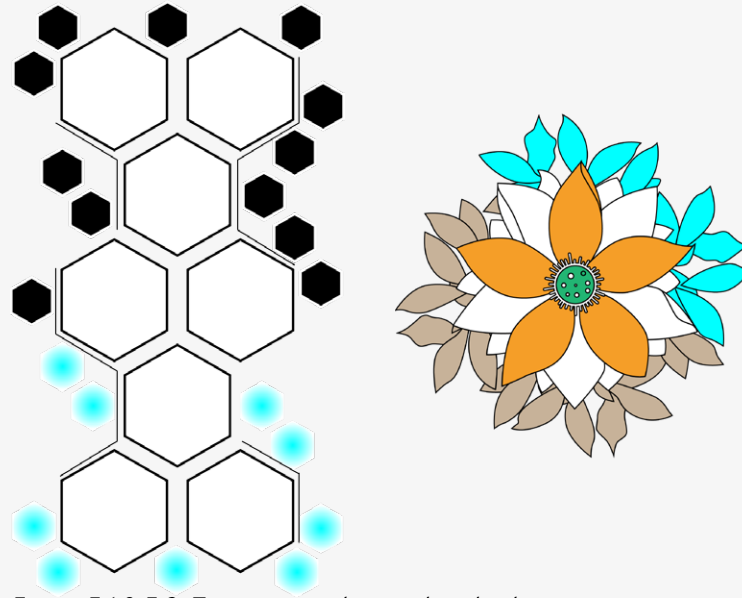

Figure 5.1 & 5.2: Tattoo examples used to display interactions



figure 5.3: Participant testing the tattoo

feedback that is given during the test is taken into account during further development of the concept. The people that were chosen were based on the earlier defined age group, consisting of 3 men and 3 women. Their feedback is only used as input and no major design decisions will be based on quantitative data from this user test. Therefore, characteristics such as background and education are considered less important for this test.

To make sure the users would experience the tattoos as realistic as possible, several mock-ups have been made. The user could interact with two example tattoos displayed on the phone (figure 5.3) to create a feeling for which type of interactions are possible. To get more feeling for the type of light that the tattoo emits, and the feeling of the material, an EL material and tattoo paper were shown to the user. At the beginning of the interview, all of these elements were introduced to the participant, and during the interview the participant also had the option to look at and experience these different elements of the tattoo.

5.1.4 Results

After the interviews were conducted, all records were transcribed and from these transcripts, quotes were written down. All these quotes were then clustered (figure 5.4) which resulted in some helpful insights.

5.1.5 Conclusions

Variables

The main insight concerns variability in the tattoo. Depending on which context the tattoo is used in, the following aspects can be different.

- Purpose
- Visuals and size
- Location of placement
- Who wears it and who interacts with it
- Interaction types and response types

What implies interaction

From the test it became clear that the used examples did not imply interaction. 4 out of 6 participants mentioned that movement in combination with a use cue would work.

What draws you to other people's tattoos?

4 out of 6 people mentioned they would be more likely to approach someone with a tattoo, if there is somehow an element in that tattoo that they can connect with. Examples are a shared interest, or a similar emblem that the participant might also wear.

Maintaining interest in different tattoos

To prevent multiple tattoos from getting boring, 5 out of 6 participants mentioned the tattoo should contain a personal or different element than other tattoos.

4.1.6 Next user test

To find out more about the variables in specific contexts, a second user test will be conducted. The goal of this second test will be to create two examples of how the interactive tattoo can be applied in a certain concept.

5.2 The variables

5.2.1 Introduction

From the exploitative user test, it became evident that there are a few aspects of the tattoo that are variable and depending on the context. In this chapter these variables are mapped out and it is briefly explained how and to what extend they can vary.

5.2.2 Size

The size of the tattoo is dependent of the placement on the body, and of the graphic of the tattoo. A limitation lies in the size of electroluminescent or thermochromic surfaces, since increasing these surfaces decreases the homogeneity of the luminance or color change.

5.2.3 Placement on the body

On the outer figures, the possible placement locations of the tattoo are indicated. These include the face, arms and legs. On the middle figures, areas are indicated that possibly inflict with the tattoo, since the skin wrinkles drastically in these places with movement. On the inner figures, it is shown which locations on the body are variable depending on the context. The arms might not be available due to sleeves, or the legs due to long pants.

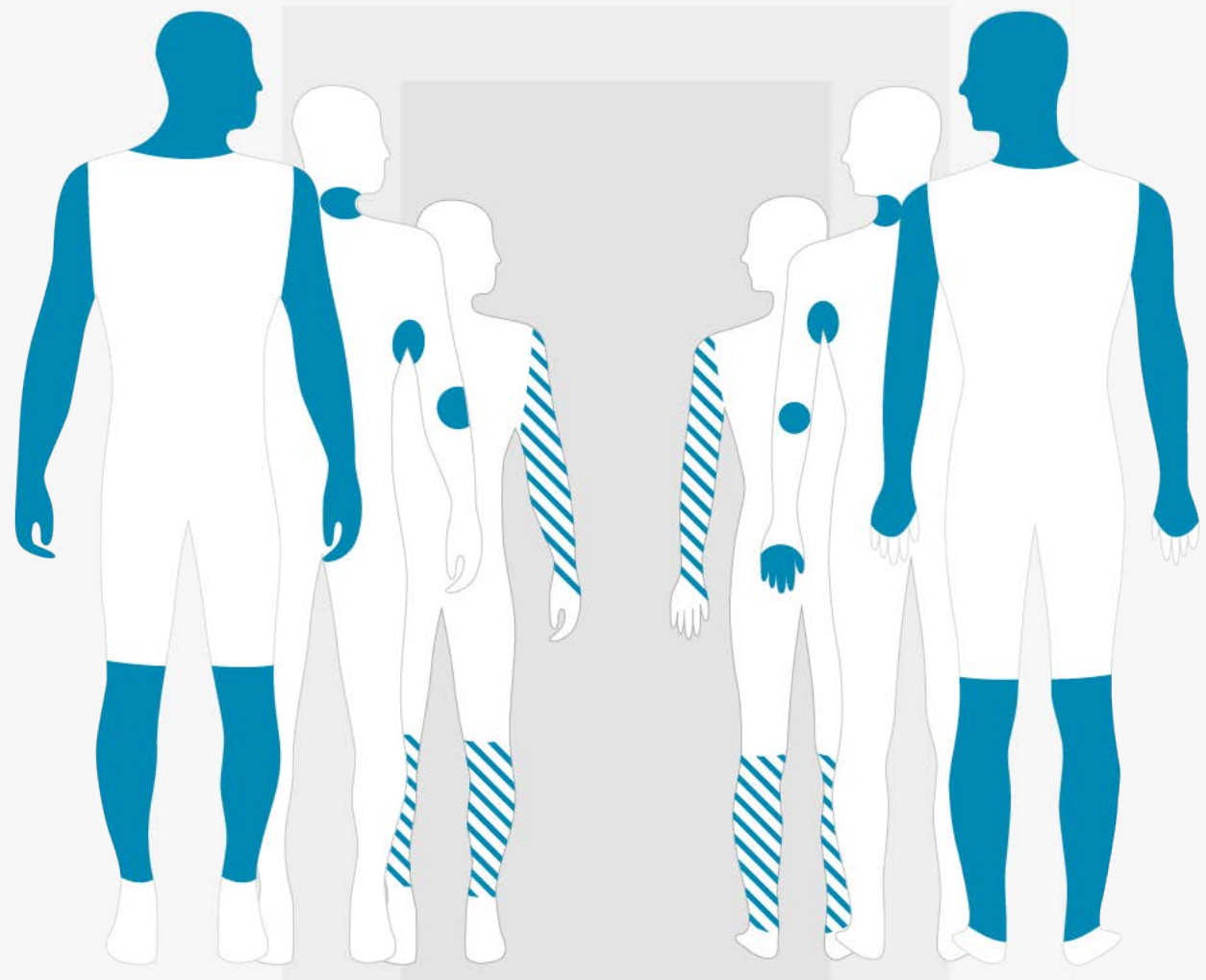

Figure 5.5: Different locations on the body where the tattoo could be placed

5.2.4 Purpose

The goal of the tattoo is evoking curiosity with others. Yet there are different meanings this tattoo could get that are able to reach this goal. Four meanings are identified here. It could express the emotional status of the wearer, it could represent the wearers identity (adding to the experience of how the wearer would like to be perceived), it could express connectivity to a group through recognition or resemblance, and it allows the user to express his interests to others.



Figure 5.6: Expressing emotional status (left) and identity (right).



Figure 5.6: Expressing connectivity (left) and interests (right).



Figure 5.7: Who wears and interacts with the tattoo?

5.2.5 Who wears it

Depending on the context, it can differ if it is either one person who wears this tattoo, multiple selected people or everyone within a restricted space of context. Depending on the context and goal of the tattoo, this can differ.

5.2.6 Who interacts with it

Just as who wears it, contains the question who interacts with it also multiple answers based on the context that the tattoo is used in. It can be either the user itself, another, a preselected person, or random people.

5.2.7 Interaction/movement types

The interaction and movement types are related to the possibilities that capacitive sensing offers. These include touch or multi touch (on different surfaces), but exclude for example the pinching movement often used in touch screens to zoom in or out.

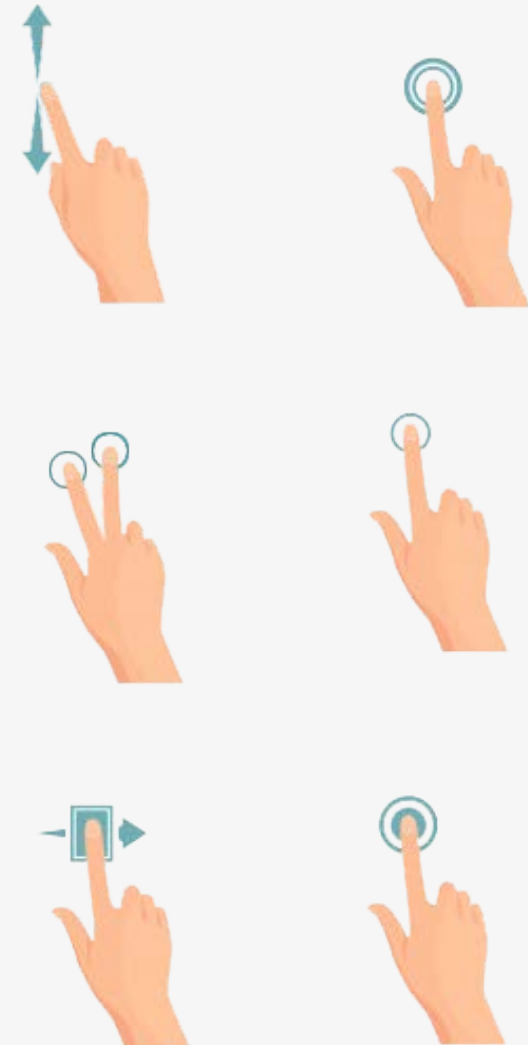

Figure 5.8: Different possible interactions



Response types

The response types are dependent of the possibilities or electroluminescent and thermochromic materials. The tattoo could light up, which could take different forms such as pulsating or at random. Thermochromic inks allow the tattoo to reveal underlying colors, resulting in color change on the tattoo.

Shape

There are many different possibilities in the shape. The tattoo could for example be futuristic or more classic. This depends on both the context as on the personal preference of the wearer. Limitations in shape lie mainly in the amount of responsive separated surfaces, and in realism. Although an extra graphic layer of ink still allows difficult shapes in the tattoo.



Figure 5.9: Different possible responses the tattoo can give

Figure 5.10: Examples of different shapes the tattoo can take

5.3 Contextual user test

5.3.1 Introduction

From the previous user test, it became clear that some aspects are context depended. To give more concrete examples of how this temporary interactive tattoo could be used in certain contexts, a follow up user test was conducted.

5.3.2 Goal

The goal of this task was to find out, for each context, which variables would be chosen, and why.

5.3.3 Setup

To enable participants to imagine the given context and options, everything was visualized. 10 participants were randomly chosen for this test. Up front, some orienting questions were asked about the user, to find out if for example their view on tattoos would bias their answers. Following, the variables and materials were introduced (figure 5.11)

The users were asked to choose their variables, per context.

Four different contexts were used during this test, which were based on the creative session results in chapter 2.5.

These contexts were:

- A party
- A festival
- A hostel
- A housewarming

5.3.4 Results

During the interviews, notes were made by a second person. After the test, these notes were summarized and combined (appendix D), to get a clear overview.



Figure 5.11: Example of the tattoo paper applied on the skin

5.3.5 Conclusions

From the four contexts, two contexts were chosen which showed the most uniform answers amongst the participants.

One of these was the party, where 7/10 indicated it could be used to display their identity. 8/10 mentioned everyone would wear one, and that the preferred interaction would be a simple tap to turn it on or start pulsating. Interesting ideas that were mentioned by participants were finding a buddy, and high fiving to turn on each others tattoos. Everyone would place it on the arm, and 7/10 said that the design should be drawing a lot of attention (e.g. big, lots of light, flashy). People also indicated the looks of the tattoo should depend on the theme of the party.

The other context was the hostel, where 6/10 mentioned the tattoo could express the wearers interests. Everyone mentioned the wearer should be only those who would like contact with others. Interaction is also mainly done by yourself (10/10), and should consist only of simple taps (8/10). Everyone would place the tattoo somewhere on the arm. Also people indicated the tattoo should be smaller than at the party (medium 5/10, small 4/10).

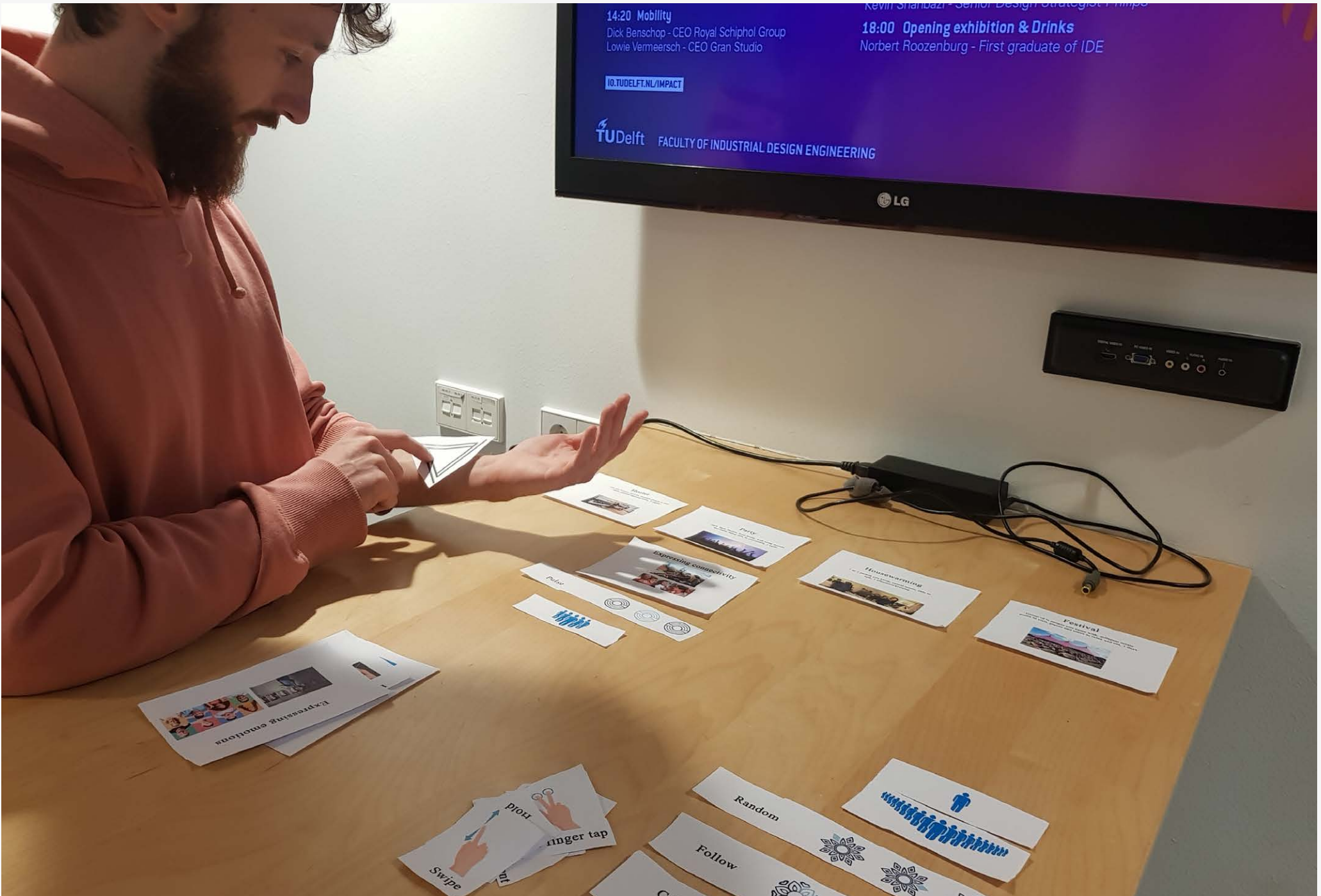

Figure 5.12: A participant trying the different interactions on his arm

5.4 Conclusion Defining solution

Through multiple user tests, the initial product idea has been detailed while going through this phase of the process. What started with just an idea, ended with a better understanding how the interface should look like, given a certain context. It also gave a better understanding of which elements should be included in the interface to spark and maintain interest, and to create connectivity to others.

5.4.1 Exploitative user test

A first qualitative exploitative test was conducted to gain insights on two prototypes. These prototypes contained many opposites, which made it easier for the participants to compare them. One was for instance more modern, whilst the other one had the shape of a more classical tattoo. The user test resulted in some interesting knowledge:

- People need to see a bit of movement in the tattoo to understand that it can be interacted with.

- If recognition is present in the tattoo of someone else, people tend to be more drawn towards that person, to start the interaction. Similarities make it easier to approach others.
- Interest is kept when the tattoos show a personal element, thus making them different. It is even more interesting if this personal or random element is hidden at first and needs to be revealed.
- The user test also resulted in a clear understanding of which properties are variable and context dependent.

5.4.2 Contextual user test

Next, a qualitative contextual user test was conducted to find out how people would design their tattoo's given certain contexts, and whether there are any similarities amongst the participants. This resulted in some new insights, for example that in some contexts people all tend to move towards the same type of design, whilst in other contexts people create really different designs. The insights from these user test helped to create the examples

found in the next chapter: Focus.

5.4.3 Next steps

The following chapter will showcase how the design can be visualized, given different contexts. It provides the final steps towards a final product, and shows its possibilities, but also its limitations.

Phase: Focus

*Introducing:
The Unexpected Tattoo*

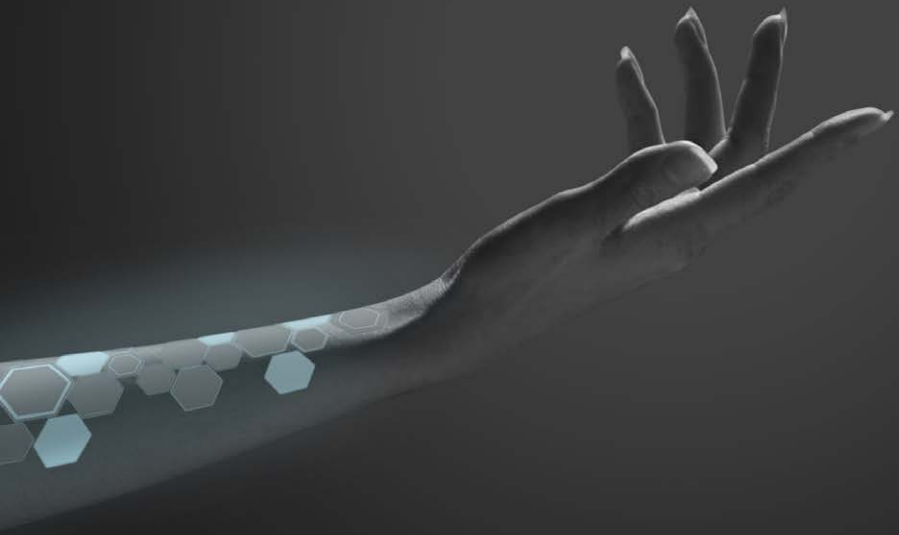

6.0 Introduction final concept

6.0.1 Developments

From the exploring solution space the initial concept arisen of a tattoo on the skin, that should evoke spontaneous interaction. To do so, it should evoke curiosity in others, and lower the threshold to approach.

Through two extensive user tests it was found out which aspects of the tattoo are variable, what draws attention in a tattoo, how the threshold to approach can be lowered, and how tattoos can maintain interest and differentiate from other tattoos. From this, the unexpected tattoo was developed. The unexpected tattoo is a tattoo that enhances unexpected interactions in multiple contexts.

6.0.2 The variables

As determined in the phase of defining solution, there are certain variables which will be dependent of the context that the unexpected tattoo will be used in, and that can be specified by the designer for that context. These variables are:

Size - The unexpected tattoo can be big or small, depending on the design and purpose

Location - Depending on the context and size, the unexpected tattoo can be placed and designed for different places on the body

Purpose - The unexpected tattoo can express:

identity, connectivity, interests and emotional status

Who wears it - It can either be one person who wears the unexpected tattoo, or many people at a certain event.

Who interacts with it - The wearer can interact with the unexpected tattoo himself, or the goal could be for others to interact with it.

The types of interaction - Depending on the design of the unexpected tattoo, the types of interactions can vary.

The type of responses - Same as the interaction types, this variable depends on what the designer would like to achieve.

The shape - This should be something that fits the context, but leaves a lot of freedom for creative input of the designer.

6.0.3 The chosen contexts

To show the different possible applications of the unexpected tattoo, the decision was made to showcase 6 different contexts and their corresponding possible usages and looks within this context. Since one of the main elements of the

unexpected tattoo is electroluminescence, which is most exciting and vivid in dark places, this was chosen as the main example. Within this context, two themed series of unexpected tattoos have been designed, which also meet the results gained from the contextual user test executed in chapter 5.3. This context also fits well within this assignment, since the barrier of approaching strangers is somewhat lower at a party compared to a regular context. Furthermore, in the context of a party people often try to stand out through their looks, which is something that this unexpected tattoo can contribute to as well.

To show that the unexpected tattoo can reach its goal through different functionalities and within different contexts, two more examples have been worked out. Here, the unexpected tattoo is displayed in the context of a hostel and during the introduction week of a school, all with the same goal of evoking unexpected interactions and enhancing the real-life social experience of the wearer.

That an interactive tattoo does not only have to be used for fun but can also help people, two more scenarios have been developed. In these scenarios, the tattoo is able to help the wearer, both with physical as with social issues.

6.1 Early adopters

As earlier discussed, one of the factors that determine user adoption is social weight. Social weight consists of four factors, of which one is social convention (Toney et al., 2013): How socially accepted is the unexpected tattoo? In order to become more known, the unexpected tattoo should be worn by early adopters, but how does this group of early adopters look like?

The early adopters are mainly young people who like to stand out from the rest and show that they do so. They want to travel to places where others around them haven't gone yet. They are busy people, who are studying but also try to meet with their friends often, either for a coffee or to go to a party. They want to use their time to the fullest, and do as much as possible. These people are most of the time connected to others through their media, to share and be social at any time.



Likes to travel

Always connected

Wants to experience and share



Very busy

Standing out from the rest



Figure 6.1: A collage of how the early adopters could look like

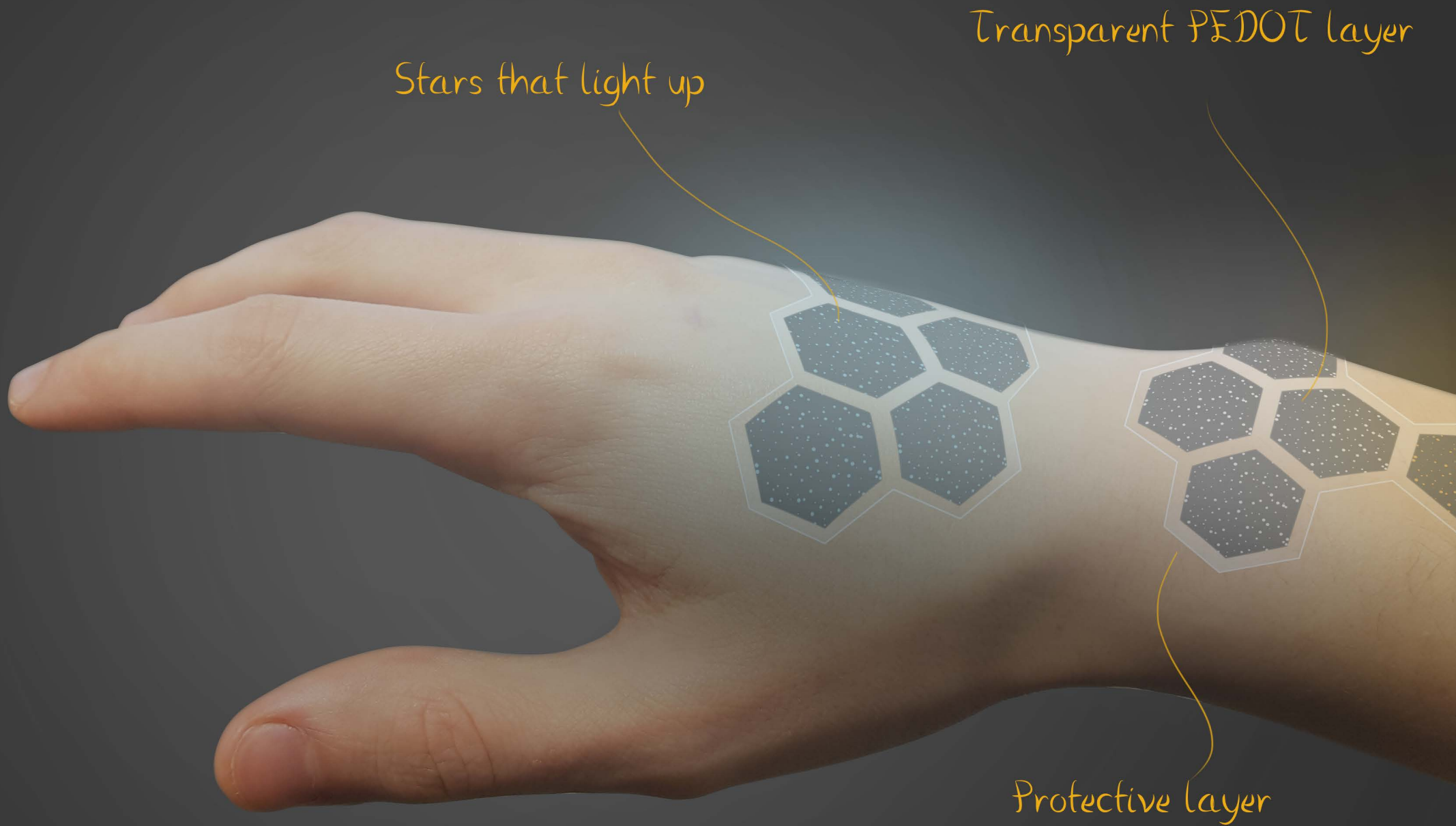

Figure 6.2: A visualization of the unexpected tattoo

6.2 At a party (Jungle theme)

A first example context of usefulness of the unexpected tattoo will be at a party, where it could be used to increase interest of other people to create unexpected interactions. One could imagine that in such a context people could wear the unexpected tattoo as an additional themed, temporary, acces-

sory. In the particular example visible on this page, the unexpected tattoo contains an element of surprise, which can vary amongst different people, and which creates an extra element of mystery and therefore interest.



Figure 6.3: People wearing the unexpected tattoo at a party



Figure 6.4: The wearer is approached by someone else

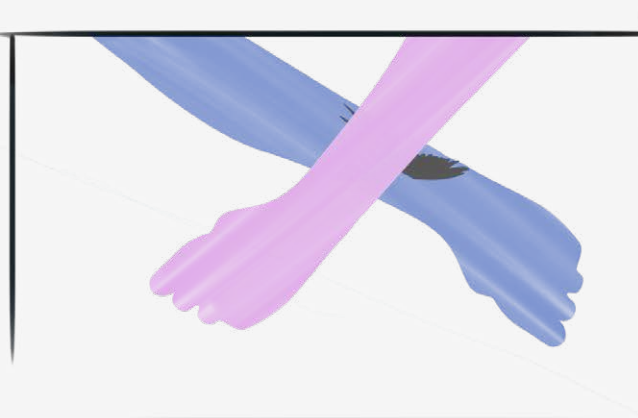

Figure 6.5: They touch their tattoos together

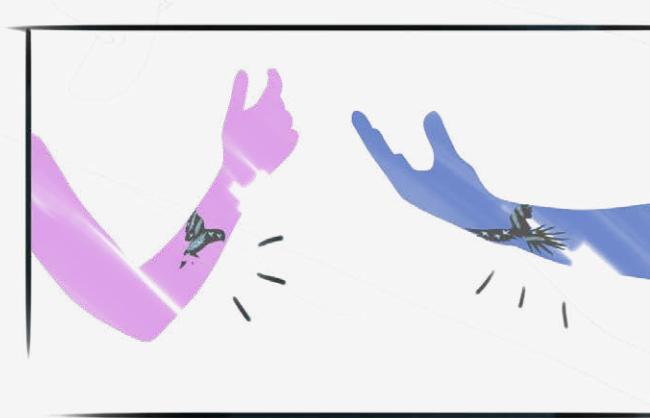

Figure 6.6: Both tattoos light up, revealing the hidden graphic.



Figure 6.7: Several examples of how the unexpected tattoo could look like in a party context

6.3 At a party (Futuristic theme)

The unexpected tattoo can be customly designed and can fit the theme of for example a party. Within this theme there is still room for creativity in design and interaction (figure 6.9) There are more possibilities than simple task and response combinations, as is visible in figure 6.8, where the unexpected tattoo is responsive to the human finger and lights up where ever the finger touches the unexpected tattoo. This will add an extra layer

of interaction between the touching person and the unexpected tattoo, and widens the options of interacting with it.

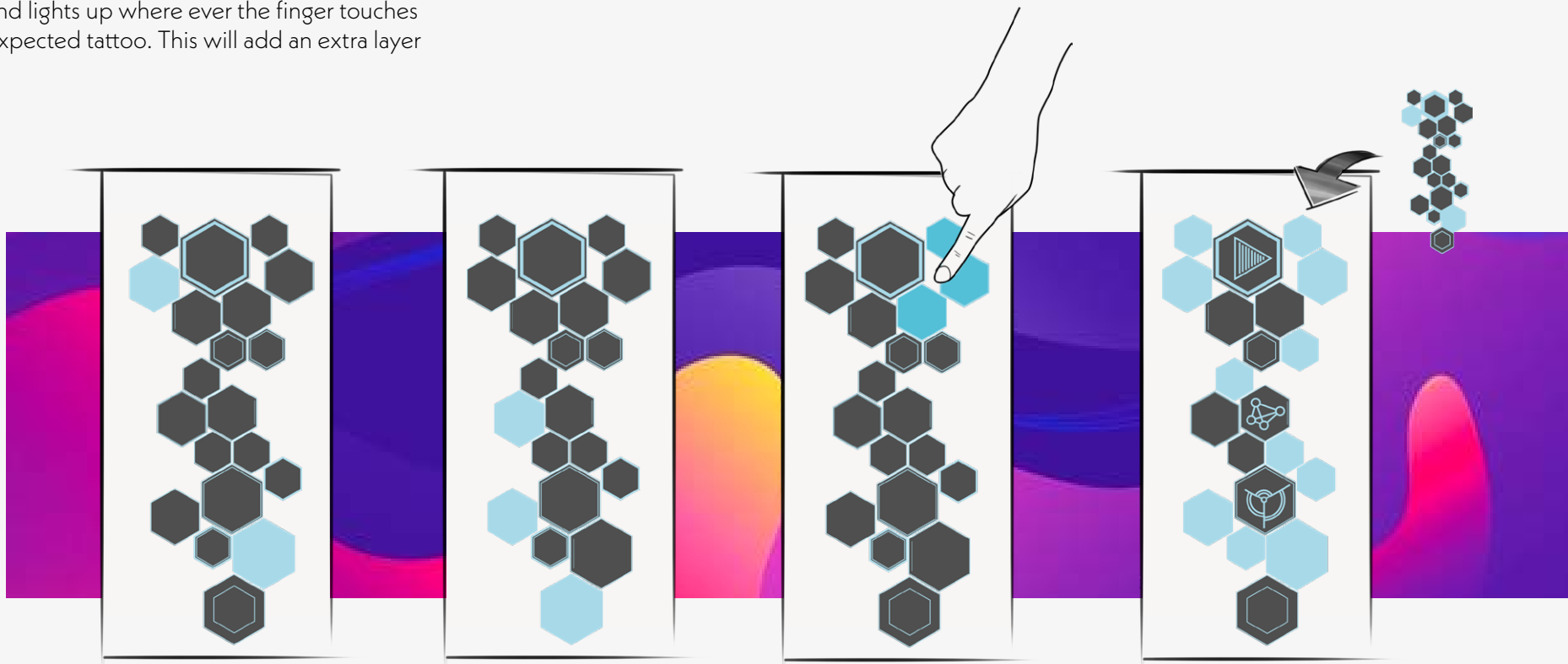

Figure 6.8: Storyboard on how to interact with the unexpected tattoo: It lights up under the finger

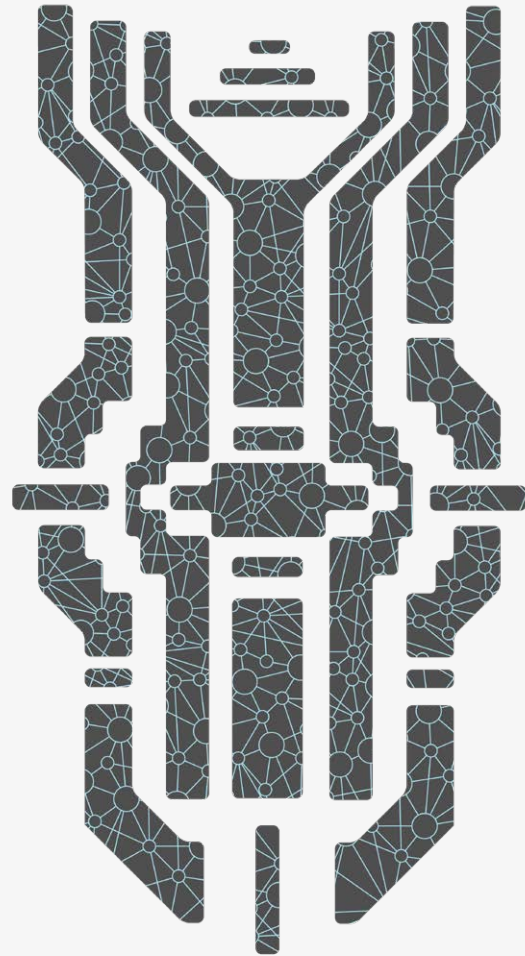
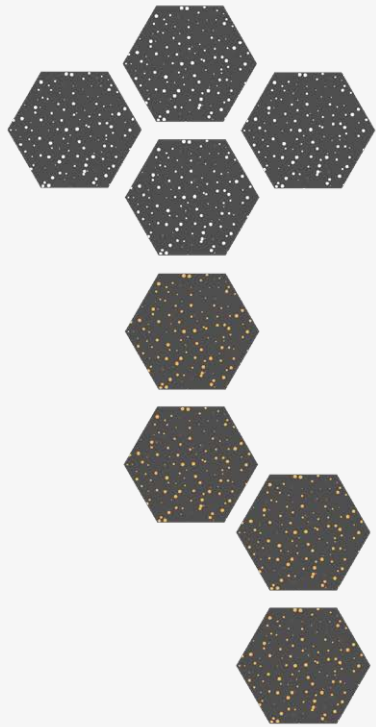
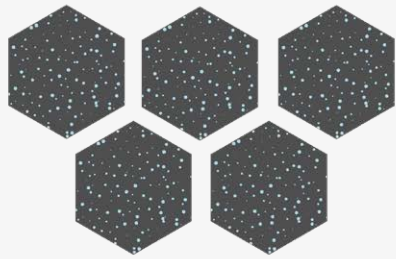

Figure 6.9: Several visualizations of how the unexpected tattoo could look like at a party

6.4 In a hostel

The unexpected tattoo could also serve a useful purpose in a hostel. The people who would like to meet new people there could wear one, which shows what they're up for doing. It makes use of thermochromic inks, which could be used to reveal parts of the unexpected tattoo and is less present compared to electroluminescence. When the wearer would like to visit a museum with someone, he could show this to others by tapping the corresponding part of the unexpected tattoo, thus revealing the image of the food bowl. When the wearer does not want to be bothered, the unexpected tattoo can be simply turned to be all black.

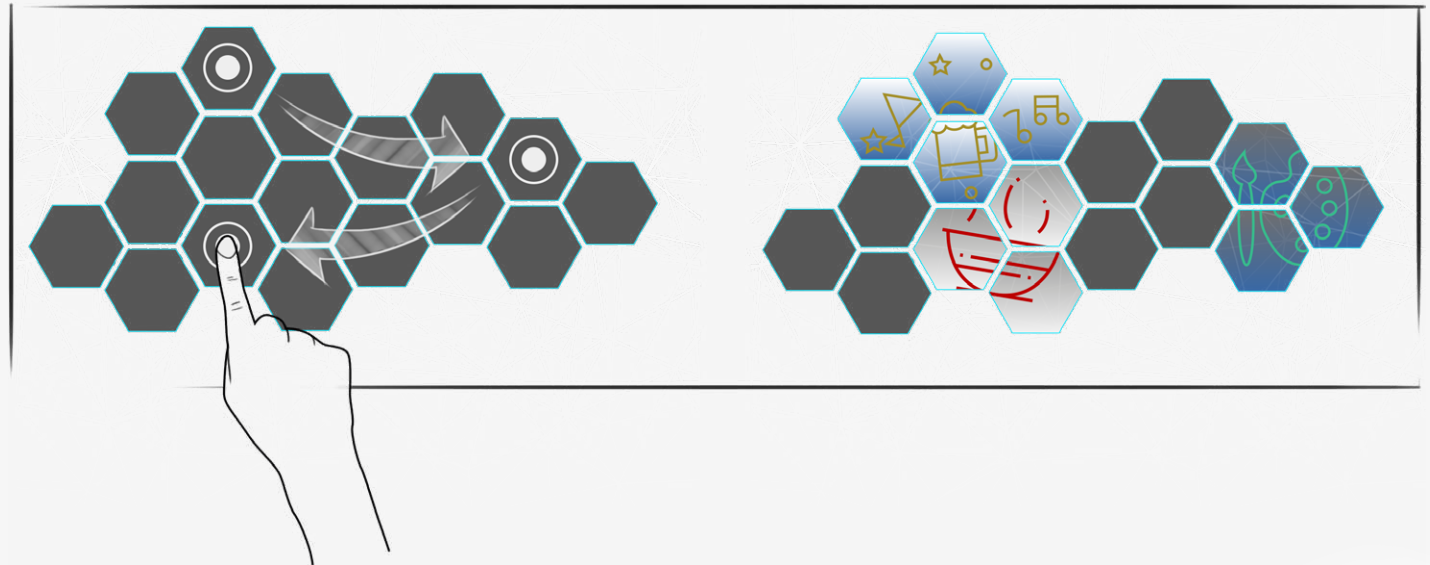

Figure 6.10: Clicking on parts of the unexpected tattoo to reveal the underlying image

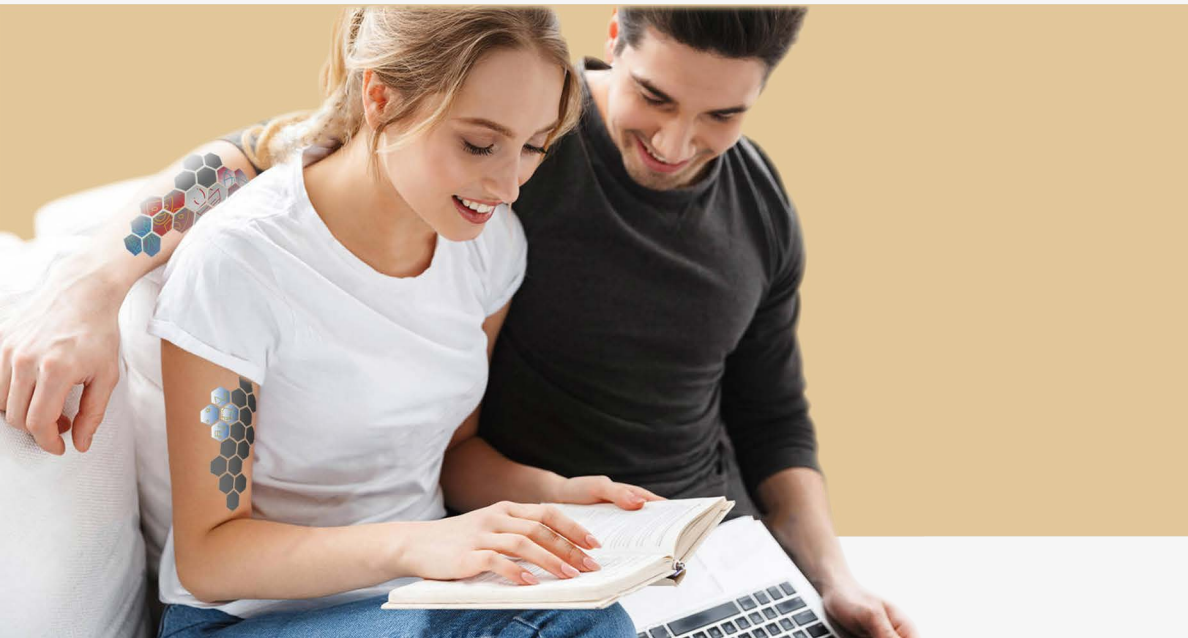
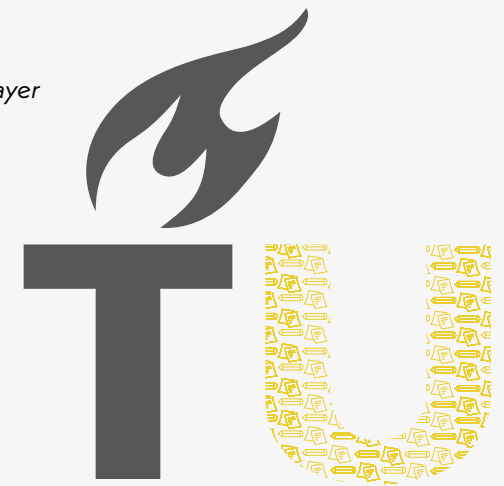

Figure 6.11: How it could be explained in a hostel what every part of the tattoo means

Figure 6.12: The TU logo as tattoo: the underlying layer of the U reveals which faculty you're from



6.5 During the university introduction week

To meet new people during an introduction week, the unexpected tattoo could be a handy tool. In this particular context, people could wear the logo of their university, to indicate them being part of the introduction week. Once two people make their unexpected tattoos touch, it can reveal something new and interesting about that person, for example which faculty he or she is from. Just as in the example of the hostel, this revealing can be done by using thermochromic inks in the top layer. In its working mechanisms, this concept

example shows much resemblance to the context of the party. This shows that there is more than one possibility where this mechanism can be used to enhance unexpected interactions.



Figure 6.13: The scenario of being new at a school and city

6.6 Helping kids with social difficulties

This context is an example of using the same principles to achieve different functionalities. Here, the unexpected tattoo can be designed for children in such a way that it can help them to get in touch with other kids. The unexpected tattoo can spark interest of others and can be used to express children in a fun and low-key way. The unexpected tattoo can for example reveal their favorite superhero or TV-show when interacted with. This should spark interest from other children and can be a first step of interaction towards a more profound level of bonding with other kids.



Figure 6.14: Different visuals that are appealing to kids

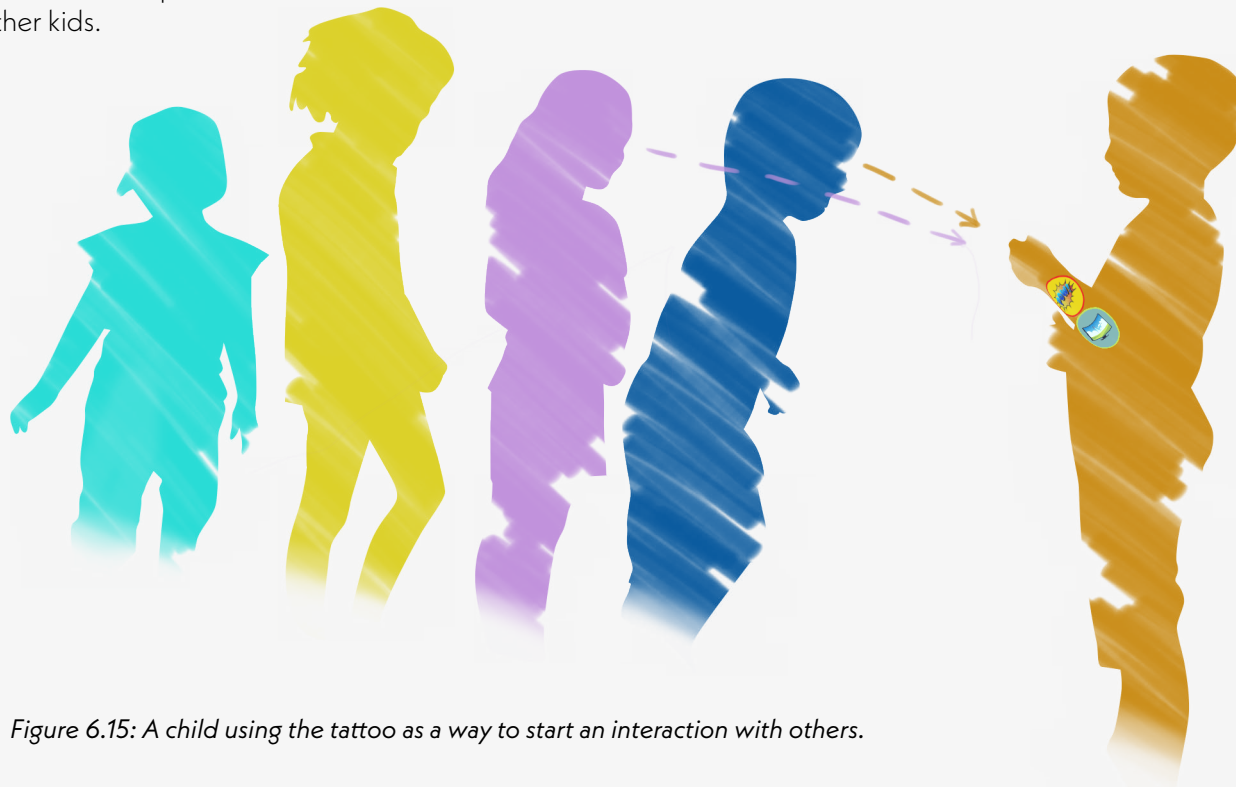

Figure 6.15: A child using the tattoo as a way to start an interaction with others.

6.7 Helping elderly with arthritis

In all previous examples, the unexpected tattoo used capacitive sensing to sense whether someone is interacting with the tattoo. With the same materials, another form of sensing can be achieved: resistive sensing. With resistive sensing the tattoo measures the resistance in the tattoo, when the resistance changes it means that something happened. This change can occur through touch of another person's hand, but it also happens when the material is bent or stretched. This opens up for new opportunities. In this example it can be placed on the arm of an elderly person to help managing arthritis. This disease requires joints to move occasionally to prevent them from getting stiff which results in pain. The tattoo can be placed on the arm and can sense whether the wearer

moves their wrists and elbows enough. If not, it can send a warning to the user. In this case that warning is embedded in a part of the same tattoo where thermochromic inks show an image when movement is needed.

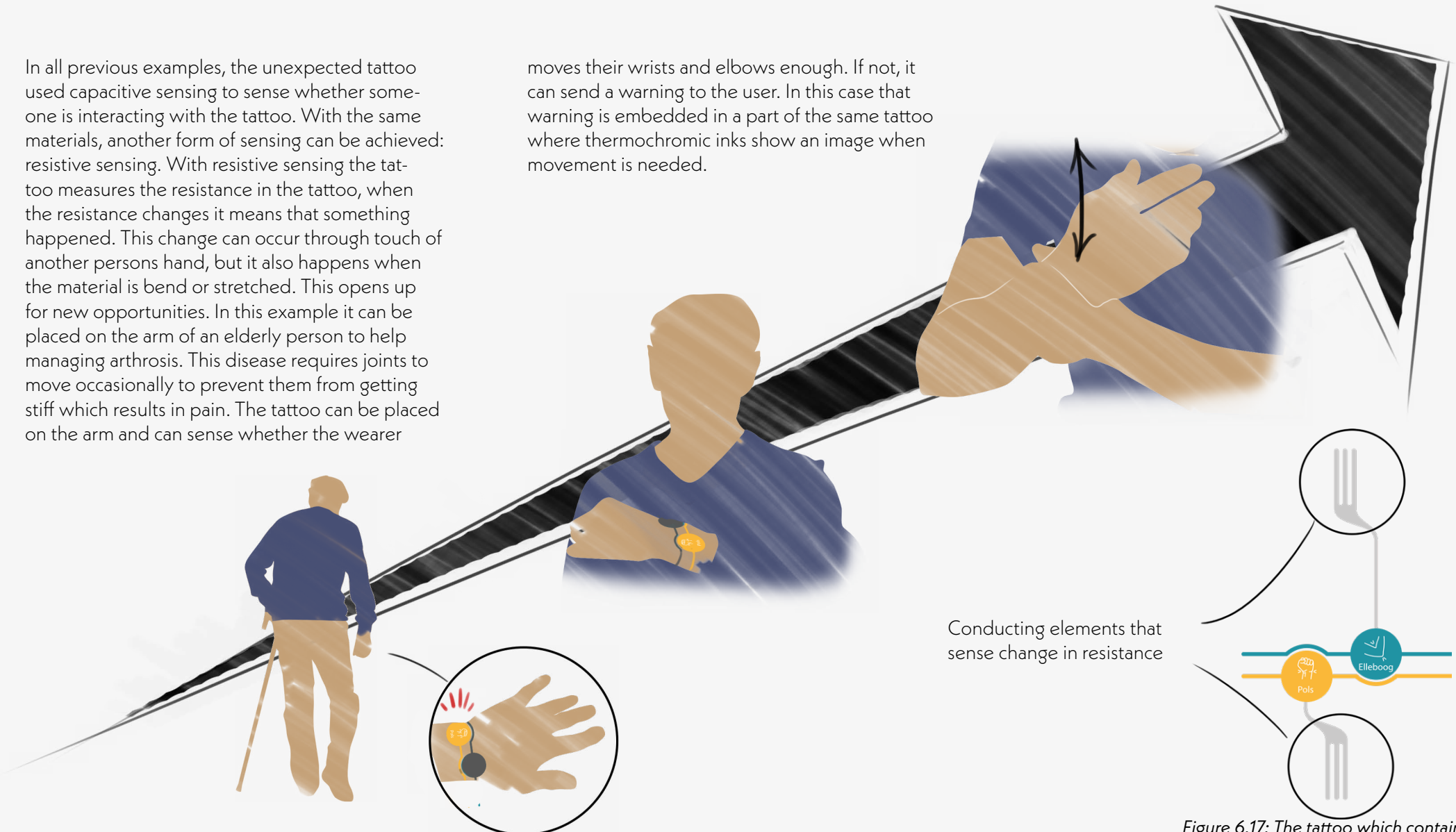

Figure 6.16: An elderly man noticing that his bracelet turned orange, which means he has to move his wrist

Figure 6.17: The tattoo which contains sensing areas

6.8 Layer build up

6.8.1 Two versions

The tattoos as described in this chapter come in two different versions. The first version is one which emits electroluminescent light (Figure 6.17, left) and the second one uses thermochromic paint to reveal an underlying layer (Figure 6.17, right). Both versions can be used in different contexts and depending on the context one fits better than the other. A context where it is mainly dark, for example in the evening, would have better use of the electroluminescent device, since it is more visible. Both versions show similarities in their build up, which will once again be explained below.

6.8.2 Electroluminescent tattoo

- Substrate: This layer protects the skin from the first electrode. It should be insulating to prevent conduction of current to the skin. A suitable choice here is the stretchable, transparent polyurethane foil.
- Electrode: Since this layer is located under the light emitting layer, it does not have to be transparent. A material such as silver conducts very good and is therefore applied here.
Phosphor: This layer emits light, and contains the graphic.
- Insulating layer: A layer between the electrodes that prevents current flow. It should be insulating and thin and therefore silicone spray is used for this layer.
- Electrode: The second electrode should let through the light from the phosphor layer, and therefore should be transparent. A suitable transparent conductor is the material PEDOT:PSS.
- Protective layer: to prevent people receiving a shock from the high voltage in the device, a preventive insulating layer should be applied on top. This layer also requires to be transparent and therefore insulating spray is a good choice here.

6.8.3 Thermochromic tattoo

The thermochromic tattoo knows two extra layers:

- Ink layer: This layer consists of regular ink and can be applied using an ink-jet printer and tattoo paper onto a stretchable substrate.
- Thermochromic layer: A layer that covers the ink layer and becomes transparent when it reaches a predetermined temperature.

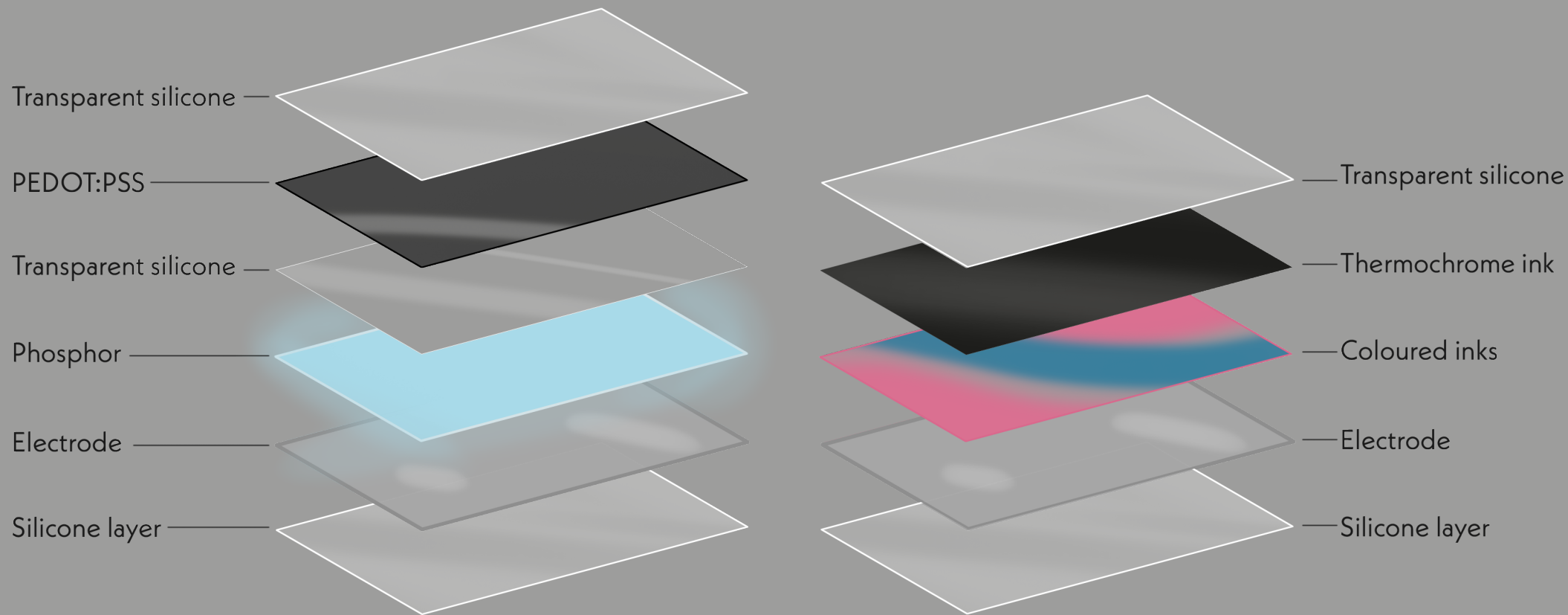

Figure 6.17: The layer build up of electroluminescence (left) and thermochromic (right) tattoos

6.9 Introduction to the prototype

6.9.1 The prototype

The final part of this project includes creating a functioning prototype to show how the unexpected tattoo would function. Since the product can take many different shapes, a choice had to be made on what the prototype should do and how it should look. During the project, much experience has been gained on creating thin EL devices, and therefore the decision was made to create this for the final prototype as well. Since it will become an interface, the device should also be responsive to input (touch), and to showcase other possibilities, the decision was made to add a fading effect to the EL part. The full flowchart of the prototype can be seen in chapter 6.11.

6.9.2 Limitations

Since designing the unexpected tattoo is easier than actually making it, and also because not every option can be in the prototype, some concessions had to be made here.

Graphic - A first concession lies in the graphic. In chapter 6.2 (party example), the graphics of the part that lights up are quite detailed. Since multiple layers of this detail have to be placed on top of each other, this would become quite difficult to create. Therefore in the prototype, a slightly simpler graphic area has been used.

Functionalities - It was not possible to include everything in this prototype. For example thermo-chromic inks are not used here, although they are shown in some of the context examples. Also there are different possibilities in the types of interaction, for example lighting up under the finger, which are not included here.

6.9.3 The graphic design

The final design is visible in figure 6.18. It contains one round tattoo and one longer one, that can be placed on either the hand or the arm. They both have lines on the outside that will fade when the unexpected tattoo is not touched, and the inner part will light up when the unexpected tattoo is interacted with.

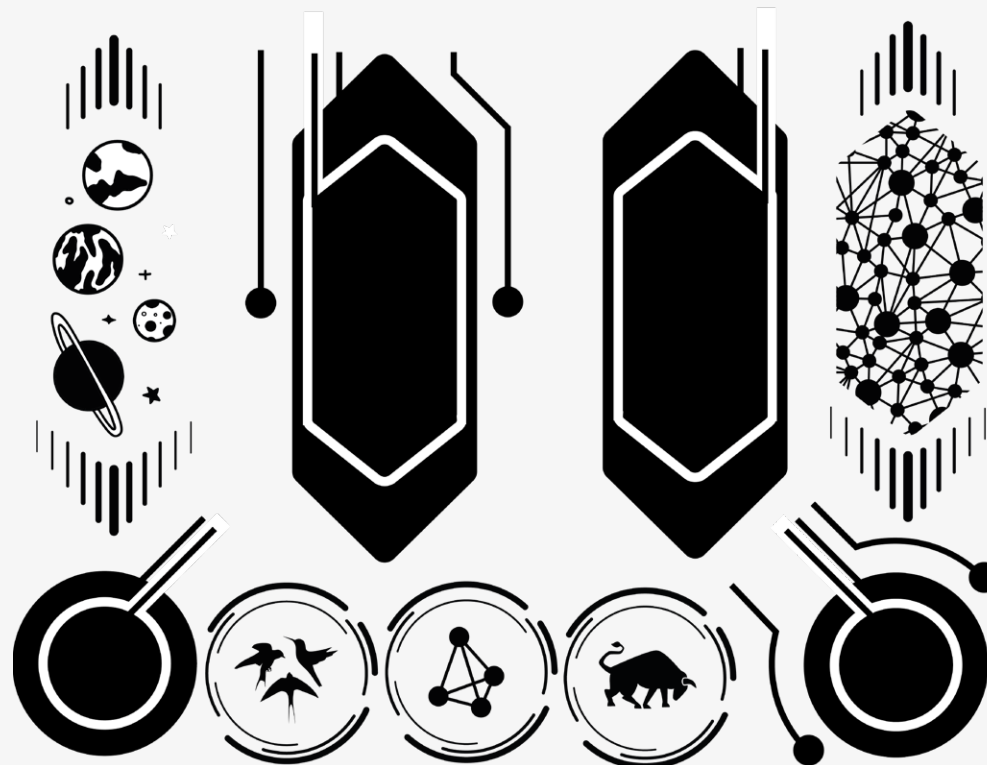

Figure 6.18: The graphic that is used to create the final prototype

6.10 Electrical build up

The tattoo prototype is built for touch detection and triggering different luminescent areas during operation. A circuit schema of the prototype is illustrated in figure 6.19 on the next page. The full arduino code can be found in appendix F.

6.10.1 Used parts

- Arduino UNO board
- n-MOSFET x2
- Resistor 10 M Ω
- Power bank (5V)
- AC converter
- Printed tattoo
 - 2 Electro Luminescent areas
 - 1 conductive area (for capacitive sensing)

6.10.2 Capacitive sensing area

Arduino's capacitive sensing configuration is used for the touch detection in the prototype. Pins 2 and 4 are connected to the resistor's edges, where pin 2 is also connected to the conductive area on the tattoo. The capacitive sensor value is measured in the code and triggered a change of state in case of detection.

6.10.3 EL areas

Arduino's PWM property is used to control the switching and brightness of the luminescent areas. n type MOSFET is connected between the ground of the Power bank and the ground of AC converter. When positive voltage is applied to the gate, MOSFET connects the source and drain. Arduino's ground is connected to the source pin of MOSFET to set a common ground between Arduino and the Power Bank. Duty cycle of the wave applied to the gate of MOSFET determined the brightness of the subject luminescent area. Digital pins 6 and 8 are configured to connect to the gates of the MOSFETs.

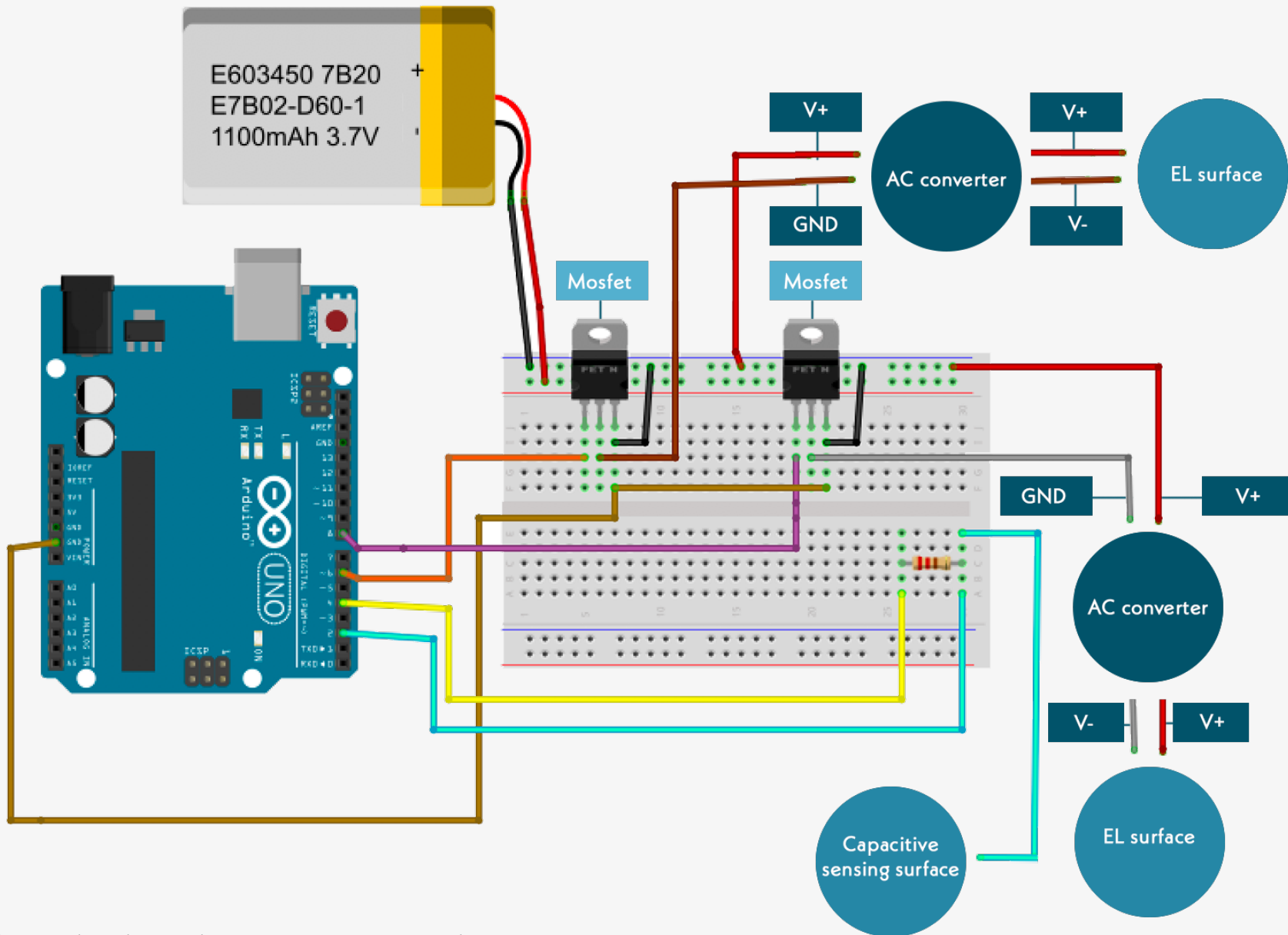
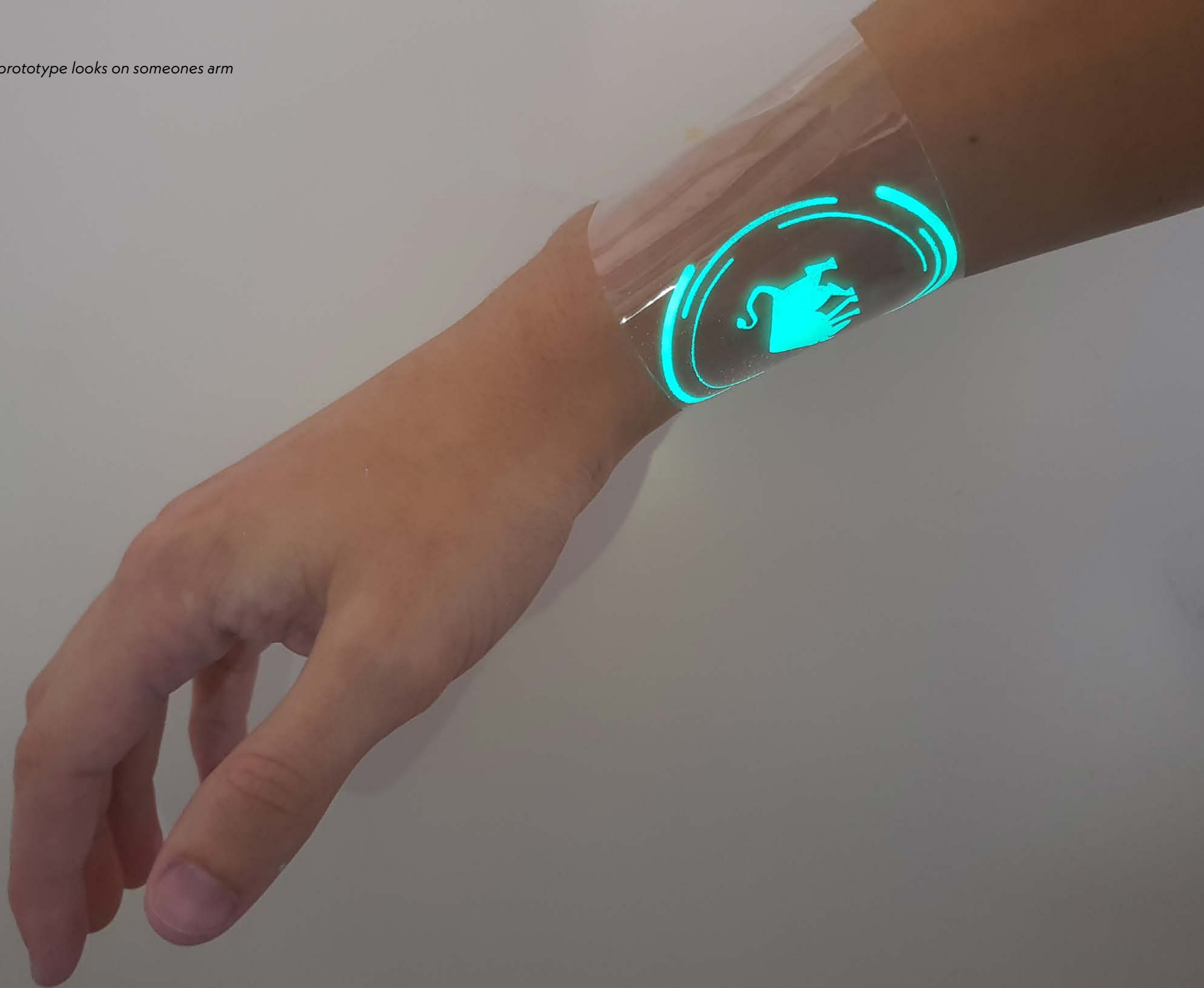

Figure 6.19: How the arduino and its components are connected

Figure 6.20: How the prototype looks on someones arm



6.11 Flow chart

I used Arduino's capacitive sensing library for sensing a touch on the tattoo, and Pulse Width Modulation (PWM) feature of Arduino. PWM is used for both for switching on/off and adjusting the brightness of the luminescent areas.

6.11.1 Lighting up

PWM enables to control the cycle of the high-low signal sent to the switches. This way, a square wave is created by switching on and off. Changing the "on time" of the square signal enables us to control the input voltage - in other words wave - supplied to the AC converter. Cycle values can be configured between 0 to 100% in Arduino, by using values between 0 to 255 with `analogWrite()` function. A smooth fading (lighting up) is achieved by using for loops and decreasing (increasing) the cycle gradually.

6.11.2 Sensing

For sensing a touch, capacitive sensing pins (configured to pin 2 and 4 in the code) read the capacitance of the human body in case of a contact. In the code, approximately every 0.1 seconds, sensor value is evaluated for a touch. A threshold value is picked based on previous readings of the test set-up. If the capacitive sensor reads above threshold, the luminescent areas are set to full brightness for 10 seconds. After then, code continues to listening for a touch and pulsating the 1st luminescent area to signal that a touch is expected.

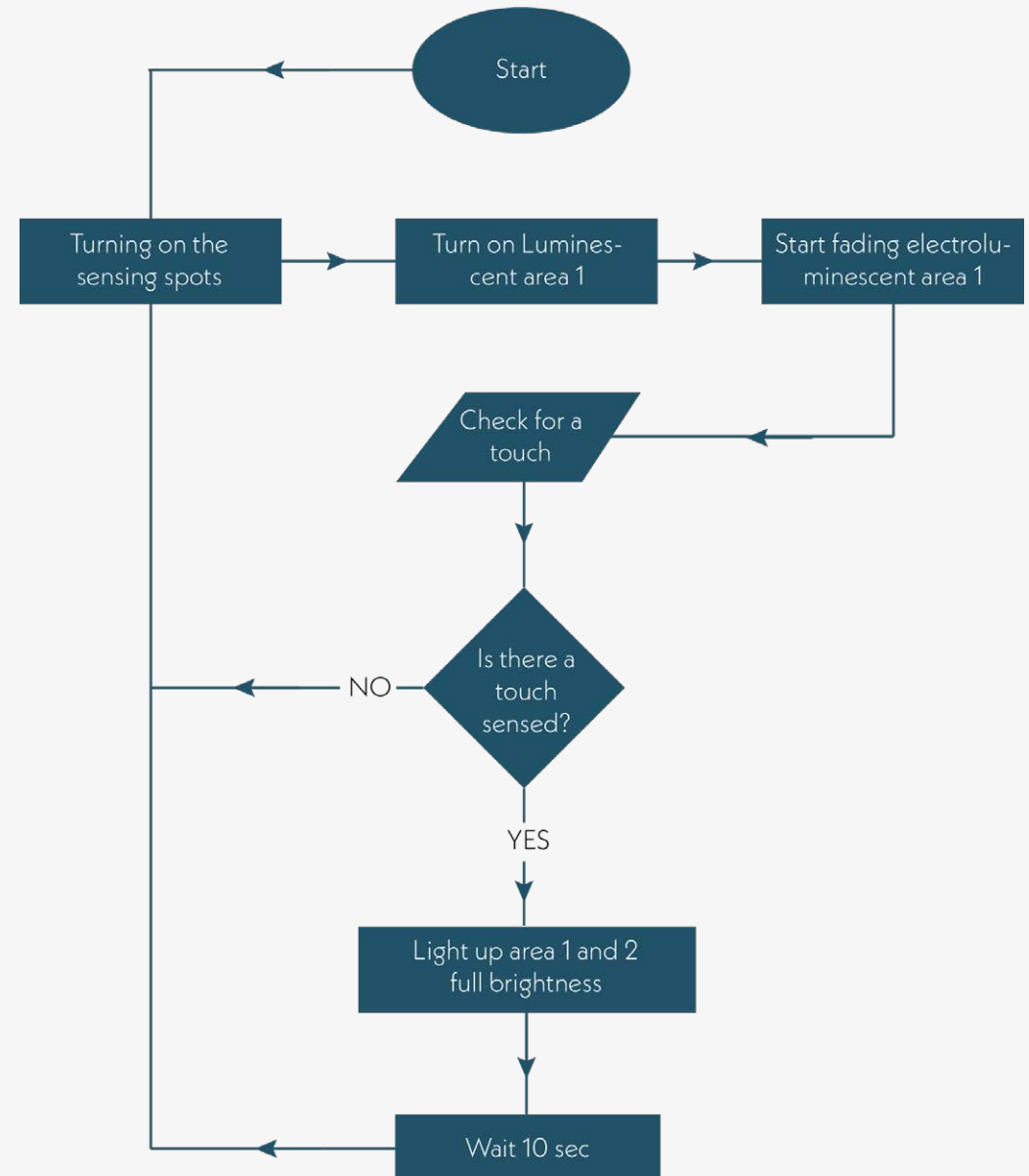

Figure 6.21: The flow chart of the prototype design

6.12 Building the mesh

To make the prototype, a mesh with the necessary prints needed to be created. Where previous small lab prototypes were created using vinyl, to create simple shapes, a more advanced shape requires a mesh. A mesh contains holes with a very high density, which can be used to apply thin layers of for example paint on a substrate, a process previously explained in chapter 3.14. To create the necessary mesh, you fill the parts of the mesh you don't want to use with an emulsion, that hardens under UV-light. The parts you do want to use you can cover with black during the curing process, which results those parts not to cure. After this process, you can wash away the parts that are not cured, and the parts that are cured will stay stick to the mesh. This way you can create your own graphic onto the mesh. A more thorough guide of making this mesh is available in appendix E.



Figure 6.22: The mesh that the prototype is created with

6.13 Making the prototype

6.13.1 Electronics

Creating the prototype consists of two parts: creating the tattoo and creating the electronics. As visible in figure 6.24, the electronic components were created using a simple tattoo version containing three surfaces where two emitted EL light and one was used to sense touch. To create the electronics, first a digital drawing was created. Next the device was built accordingly, and the corresponding code was written. To test whether the code and components worked as they should, an trial and improve approach was used here. In the end, the electronics made possible that the tattoo can fade an EL area, and completely light up when touch is sensed. To connect the tattoo with the electronics, a very thin insulated conductive wire will be used, as visible in figure 6.23.

6.13.2 Tattoo

Eventually the tattoo itself was build using the screen print method and the created mesh. For this device, the layer build up from chapter 6.8 is used. It was created in the chemical lab at TU Delft. Every layer required to be applied separately and then cured for 10 minutes in the oven at 100 degrees. As a base material, transparent polyurethane foil has been used.

6.13.3 Prototype testing

On the following pages, a brief overview of the most interesting prototype tests are visible in chronological order. Many more prototype tests have been conducted during this project, of which many also failed.



Figure 6.23: The insulated conductive wire that is used to connect the tattoo with arduino



Figure 6.24: Testing the hardware of the prototype

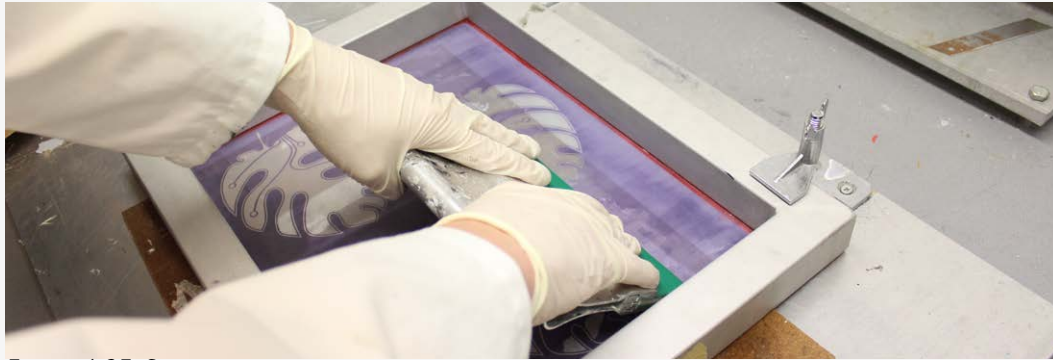

Figure 6.25: Screenprinting in process



Figure 6.26: The materials that are used to create the prototype



Figure 6.27: An older version of the prototype under UV-light



Figure 6.28: Working on the prototype

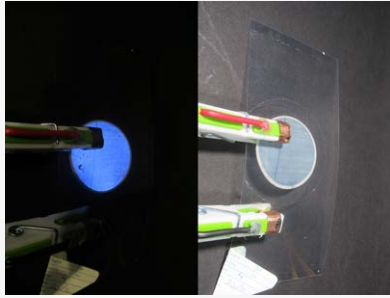

1 Simple EL device

ITO Sheet
Phosphor-White
Insulating spray
PEDOT:PSS 5%wt

2 PEDOT electrodes

PET sheet
PEDOT:PSS 5%wt
Phosphor-Blue
Insulating spray
PEDOT:PSS 5%wt
Silver for contact points

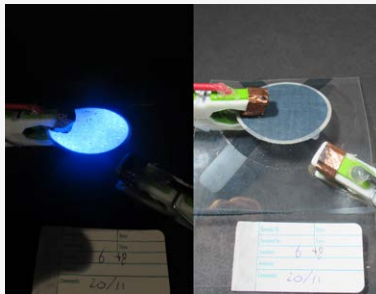

3 Using foil

PU foil (white)
PEDOT:PSS 5%wt
Phosphor-Blue
Insulating spray
PEDOT:PSS 5%wt
Silver for contact points

4 Adding wires

PET
PEDOT:PSS 5%wt
Phosphor-Blue
Insulating spray (x2)
PEDOT:PSS 5%wt
Silver and conductive wire

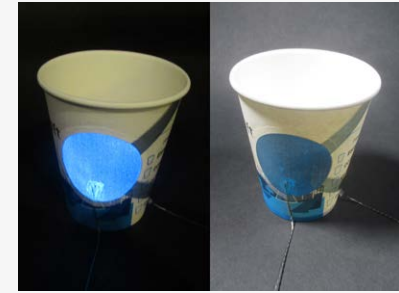
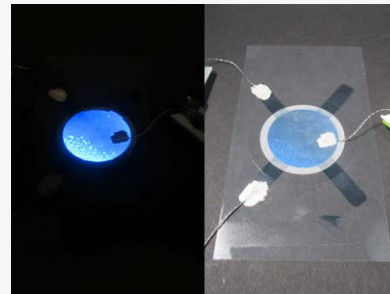

5 Tattoo paper

Tattoo paper
PEDOT:PSS 5%wt
Phosphor-Blue
Insulating spray (x2)
Silver
Silver and conductive wire

Figure 6.29: An selection of the prototypes that are made during the process

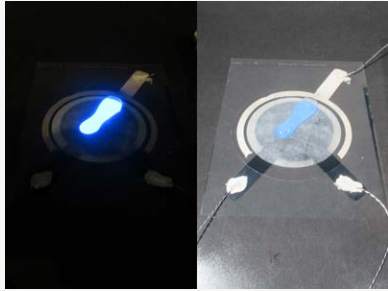

6

Water

PET sheet
 PEDOT:PSS 5%wt x2
 Phosphor-Blue
 Insulating spray (x2)
 Silver
 Silver and conductive wire

Colored inks

PET
 Aquaplast + black
 thermochromic pigment

8

Transparent PU

Transparent PU film
 Silver
 Phosphor-Blue
 Insulating spray 2x
 PEDOT:PSS 5%wt
 Silver and conductive wire



Small design

ITO sheet
 Insulating spray (x3)
 PEDOT:PSS 1,3%wt (x2)

10

Mesh density

Phosphor
 Silver
 PEDOT:PSS 1,3%wt



7



9

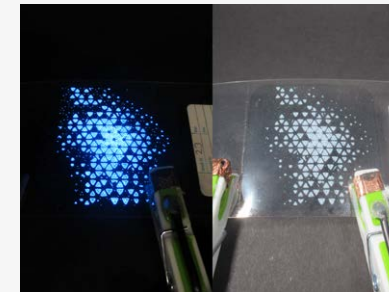

6.14 Creating the visuals

To show and experience how the unexpected tattoo would feel on the skin, and how it would be perceived when worn, a graphic was put created using the mesh. In figure 6.31, a perception is visible on how the tattoo would look when worn by someone. One thing that stood out was that a bigger tattoo is more complicated to fold around the arm. Parts of the unexpected tattoo that are not supposed to light up, should therefore be cut to create more freedom when folding the unexpected tattoo around the arm.

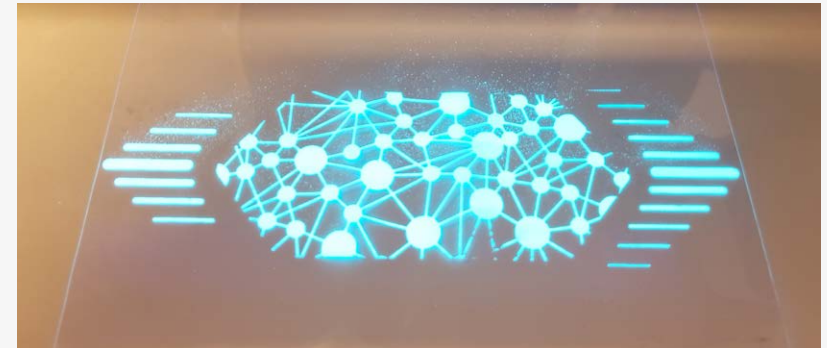

Figure 6.30: Two of the final graphics under UV-light

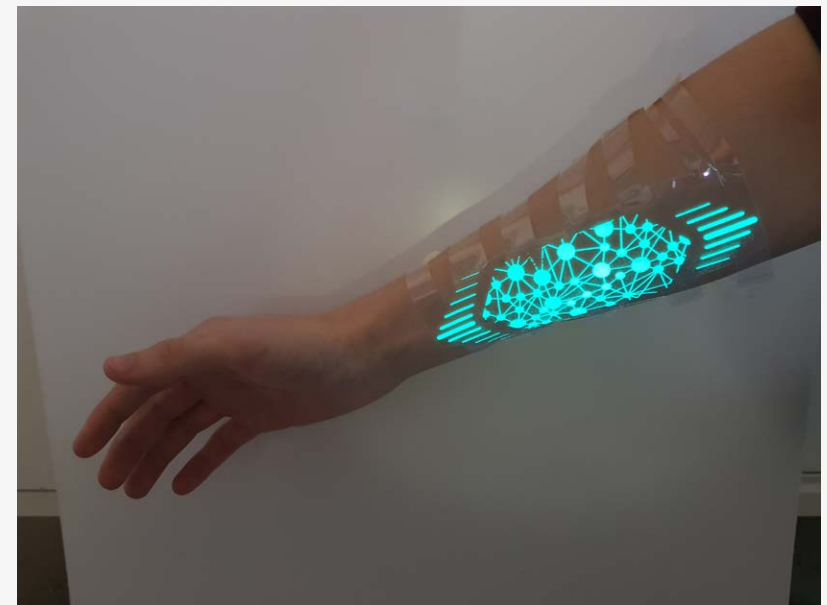

Figure 6.31: One of the graphics onto an arm

6.15 Conclusion Focus

In the chapter focus, the final concept gained example embodiments within predetermined contexts. As in the contextual user test in chapter 5.3 resulted in one context where the design was most distinctive and uniform, the context of a party was chosen to be expressed most elaborate. This context shows two different themes, to express the expressive and functional freedom the design has to fit to the user group's needs, even within the same context. To show how the same principals of revelation and connectivity within the tattoo can be applied into different contexts but for the age group, the examples of the hostel and introduction week are shown. In these examples, the user requires less attracting tattoos and therefore thermochromic inks are used here.

To showcase that an interactive tattoo on the skin can be used for more purposes than in the area of 'fun', two extra examples are added. In one, the tattoo can help kids that have social difficulties to get in touch with others of their age, since the

tattoo gives them a conversation starter or something that sparks the interest of others. In the other example the tattoo can be used to remind elderly to move their joints regularly, to prevent them to stiffen up.

There are many more of these types of examples that one could think of, which are not about communication to oneself or others. The tattoo could for example emit UV-free blue light to the user's skin, as a psoriasis treatment to the skin, which makes the skin smoother. This application can be placed in the category of healthcare, which has numerous uses for the tattoo.

6.16 Reflection on user adoption and persuasive design

6.16.1 Criteria

To assess and evaluate whether the product is likely to reach its goal (enhancing unexpected interactions), we can look back at chapter 2. This chapter states that for the product being able to execute its functions successfully, two factors are important: the design should persuade the user and successful adoption by users should be present.

6.16.2 Persuasive design

Motivation - Looking at Foggs behavior model in chapter 2.10, a product can either add to motivation, ability or serve as a trigger. In this case, the motivation should be more present in the user than that it is stimulated from the product. If you would like to meet new people in real life, than you have a higher motivation to wear this product.

Ability - Here, the product has added value. It makes it easier to cross the barrier of approaching another person, since it gives people something in common or a reason to approach.

Trigger - This device is not so much a trigger for the wearer, but more for others around him. Once others see it on your body, they could potentially start thinking about approaching you. It would work the same the other way around: when you see someone else's tattoo it could spark the thought of approaching that someone within yourself.

6.16.3 User adoption

Functional needs - Looking at Maslows pyramid of hyarchical needs in chapter 2.3, the benefits of this product can be scaled in the third layer: bringing love/belonging.

Cognitive attitude - Cognitive attitude can be split in two parts: perceived usefulness and perceived ease of use. Perceived usefulness expresses how well the product is at enhancing its main task: having unexpected interactions. This is something that requires an in context test in order to be assessed properly. On perceived ease of use it would be rated good, since the device only contains an easy

basic interaction: it requires to be touched by the user or by others.

Social aspects - As stated in chapter 2.5, this aspects can be split into 4 factors:

Cognitive load - The effort to perform a gesture with this product is not more than the interactions with a phone, it just requires a simple touch on the tattoo.

Physical presence - The device is present and hidden at the same time. It requires to be present and be seen by others to execute its function, but can be perceived as a normal tattoo as well which doesn't attract attention.

Technology apprehension - The device requires introduction and showcasing by early adopters or influencer for the gestures and technology to be more understood by the big public.

Social convention - The device would probably be socially accepted, since it has much resemblance with conventional tattoos, which people are used to. This can be compared to the smart watch which

is also widely accepted because people were already used to others wearing conventional watches, and the switch is therefore not that big.

Physical aspects - This factor can be divided into two:

Comfort and safety - The comfort can be rated as high, since the device is very lightweight and barely noticeable when wearing. It is also safe to use, since it contains insulating layers on both sides of the tattoo, which prevents people from receiving a shock.

Aesthetics and experience - With the tattoo, people can express themselves, since the tattoos are customizable and thus can be altered depending on the wearer. The device could for some refer to conventional tattoos, which do not for everyone have a positive stigma.

Mobility - The device is very portable. It does not require any effort to be carried, and can be easily put on and taken off the body.

6.16.4 Conclusion

The tattoo is sufficient on most criteria stated above. For some, for example referential aesthetic experience, a user test would be helpful as a way to find the true sufficiency of the product. Using the above-mentioned criteria are also helpful in assessing whether on which points the device would require most improvements when the concept would be further developed.

Phase: Conclusion



7.1 Conclusion

7.1.1 Has the Assignment been met?

The assignment, as stated in the project brief is: Designing an interface using thin and flexible/stretchable sensors and actuators, for future human computer interaction located on the body. The device should have a useful purpose and help the user in performing an interaction that improves or enhances the users experience or execution of a certain activity.

This assignment can be split in four different parts on which can be reflected:

An interface containing thin and stretchable sensors and actuators

It can be concluded that this part of the assignment has been met: the final design has the capability to either contain a capacitive or resistive sensor. It also contains an actuator: either thermochromic inks or electroluminescent materials that cause a response towards the user input.

For future HCI

Using the VIP method, the concept that has been developed during this project was aimed at futuristic and novel HCI. Since it includes a product that is not yet on the market, nor is a similar product, it contains corresponding types of interactions that are not yet common. More bodily technology will include different and new types of interactions with others, since its placement and function will be different from what there is currently on the market.

Useful purpose

The design has as an underlying function to decrease the use of conventional technology in unwanted situations, and its corresponding effects. Therefore the design can be considered as being useful for the user.

Enhances user experience or improves executing a certain activity

During the design process, a human centered approach was used in order to move towards a design that meets the users preference as much as

possible. The goal of evoking unexpected interactions amongst people has as a result it will enhance people's experiences and certain contexts. Yet, a proper final evaluation test with several functioning prototypes will give more insurance whether or not the device in its current shape really enhances user experience within a given context.

7.1.2 Has the design brief been met?

The final concept meets all requirements that follow from the project assignment. Yet, a final evaluation test allows for more validation on the degree of presence of enhanced user experience and to which extend the device really enables people to have more unexpected interactions with others.

7.2 Limitations

There are certain things and decisions that are made during the design process, that could have contained more in depth research or user testing, but had to be done considering the time that was given for this project. In this chapter, three points during this process will be highlighted and a suggestion will be given how these points can be improved when having more time.

7.2.1 The openness of the assignment

This assignment was started with a very open brief: Design an interface on the skin. To come to a concrete product, this brief had to be narrowed down. As there were many areas of possible usage that were left unexplored. You could think here about medical purposes or functionalities for people with disabilities. A direction had to be chosen but with more time available, other areas can be potentially interesting to discover.

7.2.2 Materials

Given the direction the assignment was tending towards, the choice was made to continue with both electroluminescence and thermochromic inks. Yet, if the process would've gone into a different direction, other materials might have been interesting to use as well.

It would also have been interesting to do more research on the different substrates that could be used on the skin. There are many materials that could be used for this, and now the decision to go for a certain material has been partially limited by time and was based on already present opportunities and knowledge.

7.2.3 Evaluating test

Due to the lack of context, it was difficult to execute an overhauling usertest of which the results would be applicable within every possible context of the tattoo. Given more time, it would be interesting to find out how people experience such a device within a specific context.

7.3 Recommendations for further research and verification

During this design process, the direction was chosen to stay true to the essence of the product: developing a tattoo-like device that is evoking unexpected interactions. Although this design brief was fulfilled up to a satisfying level, there are still several things that are recommended to work on, when this project would be continued by someone else.

7.3.1 Final evaluation test

A first point of recommendation is to execute an evaluating concept test. For this, one of the given example contexts could be chosen to be developed into a functioning prototype, which then can be tested in that actual context.

How could that test look like?

As a start, people can wear this tattoo in a low-key setting such as a cafe, whereas you can get to know how other people look towards this new type of technology, and how the wearer himself feels when wearing the tattoo. Following this, a more

extensive user test can be executed where multiple unfamiliar people wear the tattoo and through observation it is then possible to evaluate whether or not the tattoo reaches its desired effect.

7.3.2 More context oriented applications

It would be very interesting to dive deeper into a specific context. How would for example the tattoo work best during the introduction week of the TU Delft? This concept can then be further developed through user-centered design with a focus on students who are new to a city and experiencing this introduction week for the first time. The example in this report is only an estimated view of how the tattoo could work in such a situation, but it is not extensively tested which would result in much additive value for the design.

7.4 Reflection

Looking back at the design process, there have been many things that I learned and which I think made me grow as a designer.

One of the aspects that was most difficult to deal with was the openness of the assignment. Up front it seems like something that only makes it easier, since it does not limit the possibilities. Yet, it is also very constraining since there are no handles that help me in making decisions during the design process. I first had to create these handles for myself, before I could use them for decision making. Dealing with this openness was difficult, but also taught me how to deal with the situation, and how I found ways to deal with this uncertainty within the design process.

Looking back at the approach of the design process, going through the process of VIP, and doing the corresponding research was the right way of tackling this assignment and resulted in the desired final concept. Yet doing more practical research

would've helped me during the process in order to be able to better estimate feasibility of certain ideas and directions.

A third point of attention that I would do differently if I would go through this process again, is to make quicker decisions on certain things. I found it difficult to make decisions, especially during this project, always feeling that I needed more back-up to make the right decision. Yet, I feel it would have saved me time if I had just made a decision at certain points, even if later on I would have found out it is not the right one. Sometimes designing through trial and error and going with your gut feeling is a better approach than trying to find every argument within a decision you have to make.

7.5 References

- [1] Adam, H., & Galinsky, A. D. (2012). Enclothed cognition. *Journal of Experimental Social Psychology*, 48(4), 918-925.
- [2] Aitken, D., Burkinshaw, S. M., Griffiths, J., & Towns, A. D. (1996). Textile applications of thermochromic systems. *Review of Progress in Coloration and related Topics*, 26, 1-8.
- [3] Barker, E. (2018). This Is How To Increase Your Attention Span: 5 Secrets From Neuroscience. Retrieved 20 August, 2019, from <https://www.bakadesuyo.com/2018/03/attention-span/>
- [4] Bau, O., & Poupyrev, I. (2012). REVEL: tactile feedback technology for augmented reality. *ACM Transactions on Graphics (TOG)*, 31(4), 89.
- [5] Bell, Q. (1992). *On Human Finery*. : Allison & Busby.
- [6] Benafan, O., Noebe, R.D., Garg, A., Bigelow, G.S., Padula, S.A., Gaydosh, D.J., Schell, N., & Vaidyanathan, R. (2013). High Temperature Shape Memory Alloy.
- [7] Brod, C. *Technostress: The Human Cost of the Computer Revolution*, Publisher Addison-Wesley (February 1984)
- [8] Bodine, K., & Gemperle, F. (2003, October). Effects of functionality on perceived comfort of wearables. In *Seventh IEEE International Symposium on Wearable Computers, 2003. Proceedings.* (pp. 57-60). IEEE.
- [9] Boscart, V. M., McGilton, K. S., Levchenko, A., Hufton, G., Holliday, P., & Fernie, G. R. (2008). Acceptability of a wearable hand hygiene device with monitoring capabilities. *Journal of Hospital Infection*, 70(3), 216-222.
- [10] Buehler, W.J., Gilfrich, J.V., & Wiley, R.C. (1963). Effect of Low-Temperature Phase Changes on the Mechanical Properties of Alloys near Composition TiNi.
- [11] Cao, Q. and Rogers, J. A. (2009), Ultrathin Films of Single-Walled Carbon Nanotubes for Electronics and Sensors: A Review of Fundamental and Applied Aspects. *Adv. Mater.*, 21: 29-53.
- [12] Cossu, M. (2011). *Silkscreen Basics: A Complete How-to Handbook*. : Ginko Press.

- [13] Csibi, S., Griffiths, M. D., Demetrovics, Z., & Szabo, A. (2019). Analysis of Problematic Smartphone Use Across Different Age Groups within the 'Components Model of Addiction'. *International Journal of Mental Health and Addiction*, 1-16.
- [14] Czimmek, P. (2004). Characterization of magnetic shape memory material. Siemen VDO Automotive Engineering Report.
- [15] Davis, M. (2018). What Are Inorganic Compounds?. Retrieved 20 August, 2019, from <https://study.com/academy/lesson/what-are-inorganic-compounds-definition-characteristics-examples.html>
- [16] Duerig, T. W., & Pelton, A. R. (1994). Ti-Ni shape memory alloys. *Materials properties handbook: titanium alloys*, 1035-1048.
- [17] Dunne, L. (2010). Smart clothing in practice: key design barriers to commercialization. *Fashion Practice*, 2(1), 41-65.
- [18] Dunne, L., Profita, H., & Zeagler, C. (2014). Social aspects of wearability and interaction. In *Wearable Sensors* (pp. 25-43). Academic Press.
- [19] Dupont. (2012). Processing Guide for DuPont Luxprint® Electroluminescent Inks. Retrieved 25 July, 2019, from https://www.dupont.com/content/dam/dupont/products-and-services/electronic-and-electrical-materials/documents/prodlib/EL_Processing_Guide.pdf
- [20] Duval, S., Hoareau, C., & Hashizume, H. (2010). G. Cho (Ed.), *Smart Clothing: Technology and Applications*. CRC Press. Chapter 7, pp. 153-187.
- [21] Electrical4u. (2018). Materials Used for Heating Elements. Retrieved 8 July, 2019, from <https://www.electrical4u.com/materials-used-for-heating-elements/>
- [22] Fardouly, J., Diedrichs, P.C., Vartanian, L.R., Halliwell, E.(2015). Social comparisons on social media: The impact of Facebook on young women's body image concerns and mood. *Body Image: Vol: 13, March 2015, Pages 38-45*.
- [23] Fluorophore. (2019). Fluorophore. Retrieved 5 July, 2019, from <https://en.wikipedia.org/wiki/Fluorophore>
- [24] Fogg, B. J., Marshall, J., Laraki, O., Osipovich, A., Varma, C., Fang, N., ... & Treinen, M. (2001, March). What makes Web sites credible?: a report on a large

quantitative study. In Proceedings of the SIGCHI conference on Human factors in computing systems (pp. 61-68). ACM.

[25] Fogg, B. J., Soohoo, C., Danielson, D. R., Marable, L., Stanford, J., & Tauber, E. R. (2003, June). How do users evaluate the credibility of Web sites?: a study with over 2,500 participants. In Proceedings of the 2003 conference on Designing for user experiences (pp. 1-15). ACM.

[26] Fogg, B.J., Cueller, G., Danielson, D., (2007). Motivating, influencing and persuading users: An introduction to captology. The Human-computer interaction handbook: 109-122

[27] Fogg, B. J. (2009, April). A behavior model for persuasive design. In Proceedings of the 4th international Conference on Persuasive Technology (p. 40). ACM.

[28] Gausby, A. (2015) Microsoft Attention Spans Research Report. Retrieved 5 June, 2019, from: <https://www.scribd.com/document/265348695/Microsoft-Attention-Spans-Research-Report>

[29] Gopi, Kumar, Sravanth, Aravind. (2006). SHAPE MEMORY POLYMERS. Retrieved 18 August, 2019, from <http://www.dstuns.iitm.ac.in/teaching-and-presentations/teaching/undergraduate%20courses/vy305-molecular-architecture-and-evolution-of-functions/presentations/presentations-2007/seminar-1/P9.pdf>

[30] Griffiths, M. (2005). A 'components' model of addiction within a biopsychosocial framework. *Journal of Substance use*, 10(4), 191-197.

Grimnes, S. (1983). Dielectric breakdown of human skin *in vivo*. *Medical and Biological Engineering and Computing*, 21, 379-381.

[31] Hamdan, NAH, Wagner, A., Voelker, S., Steimle, J., & Borchers, J. (2019, April). Springlets: Expressive, Flexible and Silent On-Skin Tactile Interfaces. In Proceedings of the 2019 CHI Conference on Human Factors in Computing Systems (page 488). ACM.

[32] Hartl, D. J., & Lagoudas, D. C. (2007). Aerospace applications of shape memory alloys. *Proceedings of the Institution of Mechanical Engineers, Part G: Journal of Aerospace Engineering*, 221(4), 535-552.

[33] HEKKERT, P., & DIJK, M. (2011). *VIP-Vision in Design: A Guidebook for Innovators*.

- [34] Helmholtz Association of German Research Centres. (2012). Brain filter for clear information transmission: Neuronal inhibition is key for memory formation. ScienceDaily. Retrieved August 10, 2019 from www.sciencedaily.com/releases/2012/09/120906112605.htm
- [35] Heynes, T. (2018, 1st May). Harvard university. [Weblog]. Retrieved 28 August 2019, from <http://sitn.hms.harvard.edu/flash/2018/dopamine-smartphones-battle-time/>
- [36] Jani, J. M., Leary, M., Subic, A., & Gibson, M. A. (2014). A review of shape memory alloy research, applications and opportunities. *Materials & Design* (1980-2015), 56, 1078-1113.
- [37] Kahn, H., Huff, M. A., & Heuer, A. H. (1998). The TiNi shape-memory alloy and its applications for MEMS. *Journal of Micromechanics and Microengineering*, 8(3), 213.
- [38] Kim, K.S., Zhao, Y., Jang, H., Lee, S.Y., Kim, J.M., Kim, K.S., Ahn, J., Kim, P., Choi, J., & Hong, B.H. (2009). Large-scale pattern growth of graphene films for stretchable transparent electrodes. *Nature*, 457, 706-710.
- [39] Kim, J. B. et al. (2012) Wrinkles and deep folds as photonic structures in photovoltaics. *Nat. Photon.* 6, 327–332 .
- [40] Kinami, M., Crenshaw, B. R. & Weder, C. (2006). Polyesters with built-in threshold temperature and deformation sensors. *Chem. Mater.* 18, 946–955.
- [41] Kohl, M. (2013). *Shape memory microactuators*. Springer Science & Business Media.
- [42] Kulčar, R., Friškovec, M., Hauptman, N., Vesel, A., & Gunde, M. K. (2010). Colorimetric properties of reversible thermochromic printing inks. *Dyes and pigments*, 86(3), 271-277.
- [43] Kurkovsky, O. R., Rivera, O., & Bhalodi, J. (2007). Classification of privacy management techniques in pervasive computing. *International Journal of u-and e-Service, Science and Technology*, 11(1), 55-71.

- [44] Lally, P., Van Jaarsveld, C. H., Potts, H. W., & Wardle, J. (2010). How are habits formed: Modelling habit formation in the real world. *European journal of social psychology*, 40(6), 998-1009.
- [45] Lederman, S. J., & Klatzky, R. L. (2009). Haptic perception: A tutorial. *Attention, Perception, & Psychophysics*, 71(7), 1439-1459.
- [46] Lendlein, A., & Kelch, S. (2002). Shape-memory polymers. *Angewandte Chemie International Edition*, 41(12), 2034-2057.
- [47] Lipomi, D. J., Lee, J. A., Vosgueritchian, M., Tee, B. C. K., Bolander, J. A., & Bao, Z. (2012). Electronic properties of transparent conductive films of PEDOT:PSS on stretchable substrates. *Chemistry of Materials*, 24(2), 373-382.
- [48] Liu, Y., Lv, H., Lan, X., Leng, J., & Du, S. (2009). Review of electro-active shape-memory polymer composite. *Composites Science and Technology*, 69(13), 2064-2068.
- [49] Long, J., Liu, T. Q., Liao, Y. H., Qi, C., He, H. Y., Chen, S. B., & Billieux, J. (2016). Prevalence and correlates of problematic smartphone use in a large random sample of Chinese undergraduates. *BMC psychiatry*, 16(1), 408.
- [50] Lu, T., Finkenauer, L., Wissman, J., & Majidi, C. (2014). Rapid prototyping for soft-matter electronics. *Advanced Functional Materials*, 24(22), 3351-3356.
- [51] Liu, C., Qin, H., & Mather, P. T. (2007). Review of progress in shape-memory polymers. *Journal of materials chemistry*, 17(16), 1543-1558.
- [52] Markvicka, E., Wang, G., Lee, Y. C., Laput, G., Majidi, C., & Yao, L. (2019, April). ElectroDermis: Fully Untethered, Stretchable, and Highly-Customizable Electronic Bandages. In *Proceedings of the 2019 CHI Conference on Human Factors in Computing Systems* (p. 632). ACM.
- [53] Maslow, A. H. (1943). A Theory of Human Motivation. *Psychological Review*, 50(4), 370-96.
- [54] Merck kga. (2019). PDMS based polymer. Retrieved 14 September, 2019, from <https://www.sigmaaldrich.com/materials-science/material-science-products.html?TablePage=113790985>

- [55] Mohr, R., Kratz, K., Weigel, T., Lucka-Gabor, M., Moneke, M., & Lendlein, A. (2006). Initiation of shape-memory effect by inductive heating of magnetic nanoparticles in thermoplastic polymers. *Proceedings of the National Academy of Sciences*, 103(10), 3540-3545.
- [56] Ochoński, W. (2010). Application of shape memory materials in fluid sealing technology. *Industrial Lubrication and Tribology*, 62(2), 99-110.
- [57] Olberding, S., Wessely, M., & Steimle, J. (2014). PrintScreen: fabricating highly customizable thin-film touch-displays. UIST.
- [58] Ooe, M., Satoh, R., Naka, S., Okada, H., & Onnagawa, H. (2003). Painting Method for Organic Electroluminescent Devices.
- [59] PhysicsOpenLab (2019). Zinc Sulphide Phosphorescence. Retrieved 29 August, 2019, from <http://physicsopenlab.org/2019/02/06/zinc-sulphide-phosphorescence/>
- [60] Rosenthal, J., Edwards, N., Villanueva, D., Krishna, S., McDaniel, T., & Panchanathan, S. (2010). Design, implementation, and case study of a pragmatic vibrotactile belt. *IEEE Transactions on Instrumentation and Measurement*, 60(1), 114-125.
- [61] Rudell, F. (1991). Boys' toys and girls' tools? An exploration of gender differences in consumer-decision-making for high tech products. In *Conference on Gender and Consumer Behavior*. Salt Lake City (pp. 187-198).
- [62] Smooth-on. (2019). Ecoflex™ 00-30. Retrieved 10 September, 2019, from <https://www.smooth-on.com/products/ecoflex-00-30/>
- [63] Steele, R., Lo, A., Secombe, C., & Wong, Y. K. (2009). Elderly persons' perception and acceptance of using wireless sensor networks to assist healthcare. *International journal of medical informatics*, 78(12), 788-801.
- [64] Tellinen, J., Suorsa, I., Jääskeläinen, A., Aaltio, I., & Ullakko, K. (2002, June). Basic properties of magnetic shape memory actuators. In *8th international conference ACTUATOR* (pp. 566-569).
- [65] The National Institute for Occupational Safety and Health. Worker deaths by electrocution. NIOSH Publication No. 98-131. 2009, Retrieved 20 March, 2019, from <http://www.cdc.gov/niosh/docs/98-131/overview.html>

[66] The silhouette cameo store. (2019). Silhouette Temporary Tattoo Paper White. Retrieved 16 September, 2019, from <https://silhouettecameo.nl/winkel/materiaal/speciale-media/silhouette-temporary-tattoo-paper-white/https://www.sigmaaldrich.com/materials-science/material-science-products.html?TablePage=113790985>

[67] Thermo-chromism. (2019). Thermo-chromism. Retrieved 5 August, 2019, from <https://en.wikipedia.org/wiki/Thermo-chromism>

[68] Trease, B. (2004). Shape Memory Alloy Shape Training Tutorial, A Teacher's Guide To Teaching SMA Shape Training. Retrieved 20 June, 2019, from <http://www-personal.umich.edu/~btrease/share/SMA-Shape-Training-Tutorial.pdf>

[69] Toney, A., Mulley, B., Thomas, B. H., & Piekarski, W. (2003). Social weight: designing to minimise the social consequences arising from technology use by the mobile professional. *Personal and Ubiquitous Computing*, 7(5), 309-320.

[70] Wang, K., Shu, Q., & Tu, Q. (2008). Technostress under different organizational environments: An empirical investigation. *Computers in Human Behavior*, 24(6), 3002-3013.

[71] Weil, M. M., & Rosen, L. D. (1997). *Technostress: Coping with technology@ work@ home@ play* (pp. 29-32). New York: Wiley.

[72] Wessely, M., Tsandilas, T., & Mackay, W. E. (2016, October). Stretchis: Fabricating highly stretchable user interfaces. In *Proceedings of the 29th Annual Symposium on User Interface Software and Technology* (pp. 697-704). ACM.

[73] White, M. A., & LeBlanc, M. (1999). Thermo-chromism in commercial products. *Journal of chemical education*, 76(9), 1201.

[74] Wilkes, K. E.; Liaw, P. K.; Wilkes, K. E. (2000). "The fatigue behavior of shape-memory alloys". *JOM*. 52(10): 45.

[75] Winzek, B., Schmitz, S., Rumpf, H., Sterzl, T., Hassdorf, R., Thienhaus, S., ... & Quandt, E. (2004). Recent developments in shape memory thin film technology. *Materials Science and Engineering: A*, 378(1-2), 40-46.

- [76] Wong, Y. S., & Venkatraman, S. S. (2010). Recovery as a measure of oriented crystalline structure in poly (L-lactide) used as shape memory polymer. *Acta Materialia*, 58(1), 49-58.
- [77] Xenos-Despina, S., & Gregory, N. (2016). The unique properties, manufacturing processes and applications of near equatomic Ni-Ti alloys.
- [78] Xu, X., Hu, D., Yan, L., Fang, S., Shen, C., Loo, Y. L., ... & Meng, H. (2017). Polar-electrode-bridged electroluminescent displays: 2D sensors remotely communicating optically. *Advanced Materials*, 29(41), 1703552.
- [79] Yang, C. H., Chen, B. , Zhou, J. , Chen, Y. M. and Suo, Z. (2016), Electroluminescence of Giant Stretchability. *Adv. Mater.*, 28: 4480-4484.
- [80] Yang, H. , Zhu, S. and Pan, N. (2004). Studying the mechanisms of titanium dioxide as ultraviolet-blocking additive for films and fabrics by an improved scheme. *J. Appl. Polym. Sci.*, 92: 3201-3210.
- [81] Yen, W. M., Shionoya, S., & Yamamoto, H. (2007). *Phosphor handbook*. Boca Raton, FL: CRC Press/Taylor and Francis