

TYPOLOGIES:  
SMALL COMMUNITIES FOR BIG ENCOUNTERS



**MAXIMILIAN MEHL**  
MASTER THESIS  
ADVANCED HOUSING DESIGN

**Maximilian Mehl** | 5379210

Master Thesis

June 2022

Faculty of Architecture and the Built Environment

TU Delft

Advanced Housing Design (AR3AD100)

Supervised by:

Dr. Anne Kockelkorn

Ir. Olv Klijn

Ir. Ferry Adema



## ABSTRACT

Anonymity in cities and a lack of architectural identity are some of the social-architectural challenges of our time, with profound consequences for urban life. Not only does architecture have a major impact on how we experience cities and buildings, it also has an impact on our health, wellbeing and behavior. The aim of this research is to find out how residential architecture can create identity and positively influence the mental and physical health of its inhabitants. This involves architectural design principles that can respond to users' conscious and subconscious needs to their living environment.

An extensive literature search in the main areas of architectural psychology and active architecture provides insights into these issues. In addition, an analysis of case studies illustrates these issues and how they can be implemented spatially. The results show the great influence that architecture has on large parts of our lives. Among other things, it influences emotions, behavior patterns, health or the way people interact with each other. On this scientific basis, residential architecture can be designed to exert a positive influence on social, private and public life.



# CONTENT

<b>01</b>	<b>Research</b>	8
	I. Introduction	8
	II. Issues in contemporary housing	12
	III. Architectural Psychology	17
	IV. Healthy & Active Architecture	28
	V. Architectural Solutions on the example of case studies	52
	VI. Conclusion	76
<b>02</b>	<b>Urban Masterplan</b>	80
<b>03</b>	<b>Design Concept</b>	92
<b>04</b>	<b>Floorplans, Sections &amp; Elevations</b>	114
<b>05</b>	<b>Unit Type</b>	126
<b>06</b>	<b>Building Technology</b>	138
<b>07</b>	<b>Exterior Impressions</b>	152





The background of the entire page is an aerial photograph of a city, showing a dense grid of streets and buildings. A semi-transparent orange color is overlaid on the entire image, creating a monochromatic effect. The text '01 Research' is positioned in the upper right quadrant of the page.

# 01 Research

## I. INTRODUCTION

The challenge of the Graduation Studio Advanced Housing Design (AR3AD100) is to design a livable, affordable and sustainable neighborhood at a central location in Rotterdam Blijdorp, which reduces the ecological footprint and provides social inclusion to its inhabitants. The emphasis is on a holistic approach to tackle the challenges of society and to not look at them in isolation from each other.

### Theme of Investigation

The subject of this research, in short, addresses a Human Centered Design approach to residential architecture. It is a social approach that centers people in the design process to optimize positive interactions between people and buildings and can act as an improvement to the quality of life

of the inhabitants. Physical and mental needs to our built environment are largely unconscious and are expressed in behaviors, emotions, health, and wellbeing (Voegeli, 2020). The primary method of the research is based on architectural psychology, which is a subcategory of environmental psychology and studies the interactions between people and architecture (Burke, 2016). The goal is to provide a scientific approach to designing buildings in a way that satisfies the psychological needs of the users. Some of these needs are, for example, connectedness to fellow citizens and neighbors, the sense of identity and belonging to a place, the relationships we shape in our homes or aesthetic and functional needs to the built environment. Investors and communities are mostly interested in commerce or cost-cutting while architects design based on their own intuition or aesthetic values without drawing on scientific

basis (Keedwell, 2017). The second primary topic of this research addresses a healthy and active architecture. It comes with guidelines of improving the mental and physical wellbeing by design means, promotes physical movement through design solutions or helps to activate urban live through a human scale. The positive or negative effect of the built environment on our society is often underestimated. It can make us healthy or sick, smart or stupid, cheerful or depressed, motivated or apathetic (Goldhagen, 2020).

The user group I include in my thesis consists of solo dwellers and young families in the lower to middle income range, who on the one hand will make up the largest population of the city of Rotterdam in the future and on the other hand also have a difficult, financial position in the housing market. The user groups are analysed in more detail in chapter three.

## Problem Statement

In the age of globalization, cities worldwide are experiencing rapid population growth, which is accompanied by high density and expensive housing prices. This acute housing crisis is forcing people into smaller dwellings and the balance between social life and private life is becoming more difficult (Sim & Gehl, 2019). In Rotterdam alone, 34,000 households are actively looking for a house to buy, but there are only 16,900 available homes for sale (as of Oct 2021) (Kooyman, 2021). Due to the population increase together with the development of technologies and (social) media, a growing trend of anonymity in cities is emerging. While some people prefer the big city precisely because of its anonymity, which offers more privacy than suburbs, it can also have negative effects not only on social life but also on the urban city

structure. People feel pushed away and alienated from their own city and often have a negative attitude towards modern residential architecture because of their anonymity and lack of identity.

(Gorski & Sredzińska, 2017).

Another critical issue is the health of city dwellers. Loneliness, stress and depression are widespread in almost all social groups, especially in large cities, with a negative impact on mental health. In Rotterdam alone, 15% of people report feeling seriously lonely (as of Sep 2020). According to the dutch National Institute of Health & Environment RIVM, this is a high number (de Vries, 2020).

Additionally to mental health, physical health also plays an important role. Due to constant technological progress, people now sit and work with computers far more often than they did 20 years ago. Another factor is the increasing comfort of our living environment. While barrier-free access,

elevators or online deliveries of groceries, clothing and entertainment make life more comfortable, the consequence of these developments is that people move less actively and leave the house less often. A lack of movement promotes an unhealthy lifestyle and a decline in wellbeing (BETA office for architecture and the city, 2016).

Our built environment is not the sole cause of these problems, but it does play a significant role. Architects are challenged to solve many problems of our society architecturally and holistically. It is important that architects not only assess the needs of users, but also understand people's lives and their psychological connections to their living space. Architecture schools teach little to nothing about the psychology of people in relation to their environment. Yet this knowledge is essential to design appropriate living space (Wu & Zhang, 2015).



## Research Question

Based on this Problem Statement, my Research Question is as follows:

How can architecture promote a healthy, active and social lifestyle and a sense of wellbeing among residents?

How can mid-rise residential architecture strengthen a sense of community and belonging among solo dwellers and young families by design means?

## Personal Motivation

Due to the great impact architects have on the quality of people's lives, I see my biggest passion and responsibility in residential architecture. Therefore, the social character of this Advanced Housing Design studio was one of my main reasons

for choosing it. I feel a strong interest in the built environment and how the people around me perceive it differently. As an architect, I feel it is my duty to respond to the problems and challenges of our cities and to have a sound knowledge not only about technical and aesthetic aspects, but also about people and their real needs. Moreover, the heated housing market concerns me personally as well. I am shortly about to finish my master's degree and would like to buy an apartment in the near future. However, the chances on the housing market are frustratingly low with a starter salary. In addition, I have lived in various apartments, cities and countries, some of which have made me feel very uncomfortable and lonely. From my own experience I know how difficult it can be to get out of such a housing situation and that especially loneliness is not only an issue for social fringe groups but can affect anyone. I want to convert my

negative experiences by learning about psychology to understand how to architecturally influence the wellbeing of people.

## II. ISSUES IN CONTEMPORARY HOUSING

A holistic approach is needed today to address issues in a sustainable way, rather than dividing them into small pieces and addressing them separately. The built environment plays a significant factor in the way people behave and feel. As Winston Churchill once said, „We shape our buildings so that they can later shape us“. Cities around the world are experiencing rapid population growth, which poses challenges not only to planners, architects and communities, but to almost the entire urban population. Housing is in short supply. According to research by Rigo for Research & Advice, in Rotterdam alone, there is

about 50% less housing available for purchase than households actively looking for a home to buy (as of Oct 2021). This mainly affects first-time buyers and young people with a starter salary who have little chance of getting a suitable and affordable apartment for sale in the housing market (Kooyman, 2021). But not only population growth plays a role in the housing shortage, investors do as well to some extent. As shown in the 2020 data of the land registry RTV Rijnmond, 38% of the freehold apartments are sold to investors. Due to low interest rates, buying and then renting is lucrative. This leads to rising real estate prices (Lalor, 2021).

The uncontrolled growth of the population in cities also brings a growing trend of anonymity. According to the World Youth Report, in the age of globalization, the crisis of the modern city is the uneven expansion of anonymity (Gorski & Sredzińska, 2017). But it should not be seen

negatively in all aspects. Many people prefer the city precisely because of its anonymity. It offers more privacy, which they cannot find in suburbs. Most people also feel safer talking about things that might be unpopular, uncomfortable, or embarrassing. It can allow equality and free speech and encourages free personal expression (Bachmann et al., 2017). Anonymity arises in the human subconscious and is a consequence of the lack of relationships between people and space (Gorski & Sredzińska, 2017). But what are the negative effects of anonymity in cities? According to author and psychiatrist Dr Paul Keedwell, social interaction can be affected negatively as other people are perceived as irrelevant and the understanding and willingness to help towards different social groups diminishes. On the other hand, anonymity can negatively influence the perception of urban places. Undefined, random and uniform places

function primarily for passing through and may deepen the sense of anonymity in the city. No human-to-human or human-to-space relationships take place in these spaces. Social bonds or a sense of identity cannot develop, which can alter social relationships in the long term (Keedwell, 2017).

Furthermore, a lack of architectural identity can result in people not feeling connected to, caring for, or looking after their living environment. Architectural identity is a collection of values of various historical, cultural, economic or community aspects. They distinguish one place from another and give them meaning (Bahtiyar & Yaldiz, 2021). Buildings should reflect the identity of the community. According to PhD Author Martha Szejnfeld, identity describes the relationship between an individual and a space in different contexts. Architecture is about creating places that are friendly, close to people, and with which people

can identify. If this is not successful, they become only passive observers instead of interacting with these places (Gorski & Sredzińska, 2017). This topic will be discussed in more detail in chapter three.

The issue of loneliness is playing an increasingly important role in mental health in our society. It does not only affect marginalized groups and the elderly, but the number of young people suffering from loneliness is increasing, too. Loneliness is the misalignment between perception and expectations of the relationship with the environment: an unhappy relationship between people and the city. Research from the Utrecht Public Health Monitor shows that certain factors contribute to a higher risk of loneliness. These are people with a lower level of education, being part of a single-parent family, living alone, having a migrant background, being unemployed, and being 80+ years old (de Vries, 2020). According

to Dirk De Wachter, one of the most famous psychiatrists in the Netherlands says that there have rarely been so many people who have to walk alone in their lives. He sees the reason for this in the individualization, urbanization and the rise of social media (Berger, 2019). According to information from the Posad Maxwan Loneliness map, there are 56% single person households in Rotterdam Blijdorp. Of these, 13% feel seriously lonely (as of Oct 2021). However, Jacko de With, health expert of the municipality of Utrecht says that numbers don't tell the whole story. The degree of loneliness differs by neighborhood and the time of measurement. New housing projects can combat (or increase) social loneliness. It is important that neighborhoods allow and encourage people to meet. In addition, it is important to understand that severe loneliness not only has mental, but also physical health

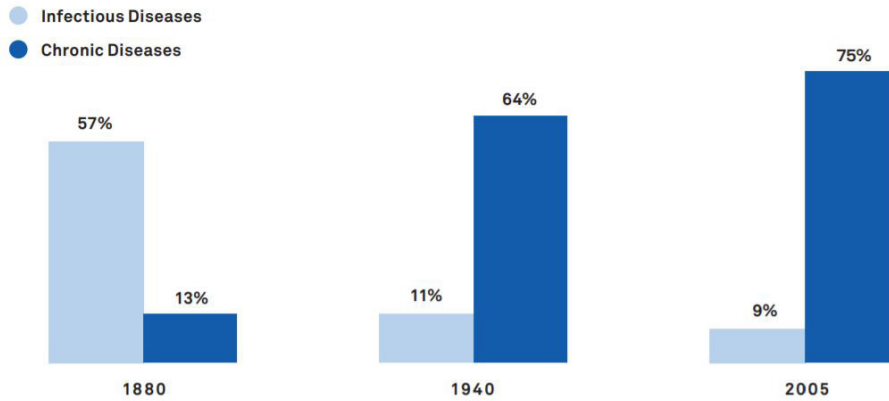


Figure 1: Development of Infectious & Chronic Diseases

effects, such as high blood pressure, diabetes, sleep problems, and a weakened immune system (de Vries, 2020). Ultimately, the built environment plays a part in our mental and physical health. One of the biggest health problems of our time is caused by overweight. Chronic diseases such as heart disease, strokes, cancer and diabetes are mainly caused by overweight, which can be traced back to physical inactivity and poor nutrition. These are major costs to the health care system (Figure 1).

Futhermore, the factor of comfort should not be overlooked. We have the possibility to have things like food, clothes or goods delivered to our doorstep. This saves a lot of time that we can use for our own leisure activities or personal relationships. However, this kind of convenience leads to significantly less physical activity (Department of Design and Construction et al., 2010). 90% of

our lifetime is spent indoors. Cities and buildings can be designed to benefit our health through active design. The global pandemic has greatly impacted health in general and the way we live, work and communicate. It has raised awareness about designing cities and buildings to promote health and wellbeing (Hojniak & Hvid, 2021).

### III. ARCHITECTURAL PSYCHOLOGY

#### A. Why a psychological approach is crucial in architecture

This section addresses the need for architectural psychology, what exactly it is, and why it can help to combat problems and challenges in architecture.

Especially in times of the pandemic, many have become aware that the spaces in which we live and work have a significant impact on personal wellbeing. Spaces influence our behavior, our relationships and our mood. They can encourage - or discourage- communication and togetherness. Architectural psychology is concerned with this interplay between spaces and emotions. Its findings can help to enhance the quality of life in our built environment (Püringer, 2021).

Architecture influences the emotional life of every person who comes into contact with it, whether positively or negatively, says British neuroscientist and author Collin Fischer (Margarete, 2018). Perceptual and thought processes, feelings, attitudes, reactions and behaviors are subjects of psychological research. Architectural psychology is the part of environmental psychology that deals with the relationships between people and the built environment. For example, why people feel a space is home or what drives people to spray graffiti on a blank wall or what makes public places worth visiting (Flade, 2020). Consequently, the appearance of buildings and neighborhoods is important not only to satisfy aesthetic needs, but to promote mental health and give places character and identity (Keedwell, 2017). According to aesthetics theory, too much simplicity promotes

vandalism and can be attributed to under-complexity (Flade, 2020). Thus, architectural psychology is a scientific research that interrelates people with space. It aims to fulfill conscious and unconscious needs and can improve mental health and wellbeing.

Architecture is omnipresent; we spend almost our entire lives in it. Buildings and cities determine how we move, how we interact with each other, and how we live and withdraw. It determines public, social, professional, commercial and private life. It can harm and isolate us, or it can uplift us and keep us active. Many architects know very little to nothing about the psychological impact of their buildings, as it is rarely taught in architecture schools. They usually design based on subjective perception. They are under pressure to consider not only social and aesthetic aspects, but also

costs, time and quality demands (Margarete, 2018).



Figure 2: The illustration shows, how school children learn the difference between a „house“ (left) and a „home“ (right)



## B. Solutions to contemporary housing issues

The following section addresses the architecture psychological approach with specific aspects of how architectural elements can enhance the wellbeing of residents. It explains the issues of identity and belonging to the home and how people respond to their built environment.

Psychiatrist and author Dr Paul Keedwell conducted a survey in 2009 with 1000 homeowners to find out how connected they felt to their home. The result was that one third of the respondents did not feel emotionally connected to their own home, even though they owned it themselves. Keedwell explains that attachment to one's home is not always possible due to stressful environments or psychological mismatch. This could be influenced by housing types, design, space, character or a

stressful location (Figure 3).

As mentioned in the previous chapter, the theme of identity, both urban and in the home, is an important factor in architecture. In an urban world that is subject to constant change and influence, the identity of the home environment becomes all the more important. It offers security, permanence, self-development and a sense of connection with the past and the future (Keedwell, 2017). People use their homes to consciously or unconsciously express something in them. On the conscious level we design our home to invite guests and to show what values we have. On an unconscious level, home becomes an expression from imprints of life, childhood, a deceased relative or relationships (Marcus, 2006). An important factor in creating identity in the home lies in having maximum control of the own living space. This control is

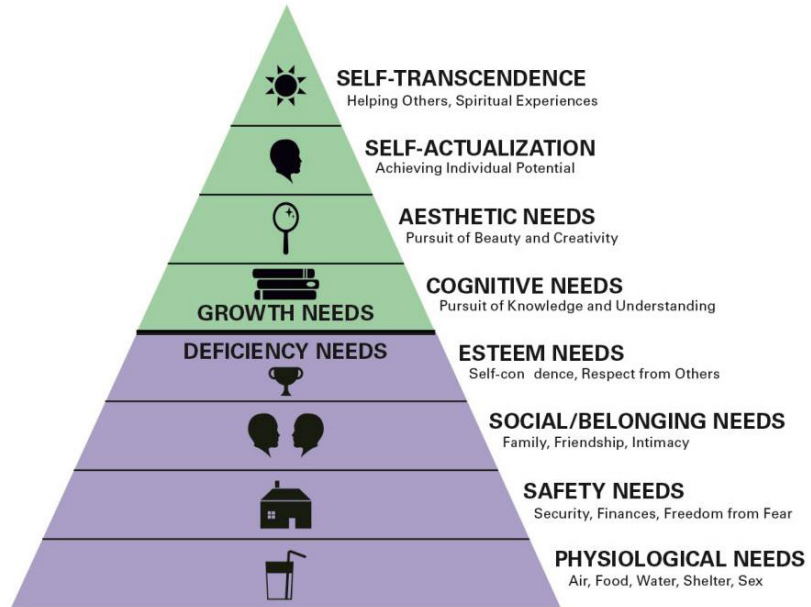


Figure 3: Maslow's hierarchy of needs- Design and Architecture impact

expressed in the design of the floor plan and the living space, the decoration, the furniture, with whom it is shared and personal objects.

An already imposed floor plan usually allows little room for structural adjustments to match individual living conditions. It involves high costs and effort that many residents are not comfortable with or can't afford. The result is living spaces that do not always meet the psychological needs or living circumstances of the residents. As a result, people may feel unconsciously limited in their lives and self-expression. Architects can respond to this by designing dwelling structures based on free, empty floor plans that can be individually designed and modified by residents before they move in. This type of design also allows future residents to easily reconfigure and customize the apartment structure and floor plan to meet future

needs and living situations. Not only does this give a sense of maximum control, but it also leads to people feeling more comfortable in general and staying in their apartment longer. Author Olivier Marc describes in his book *Psychology of the House* that the most aesthetically pleasing and psychologically healthy living space is one that is organically designed from the own needs and with local materials. This is also confirmed by Mike Hardwick, project manager and self-build expert for the National Self Build & Renovation Centre. He says those who self-build are in control of planning their own current and future needs and lifestyle. This creates a much stronger sense of place. The own ideas in the design become an expression of the own personality and create identity. Self-building not only lowers construction costs, thereby creating more living space in cities

where it is scarce, but also almost always leads to a stronger sense of belonging to the house and the neighborhood (Figure 4).

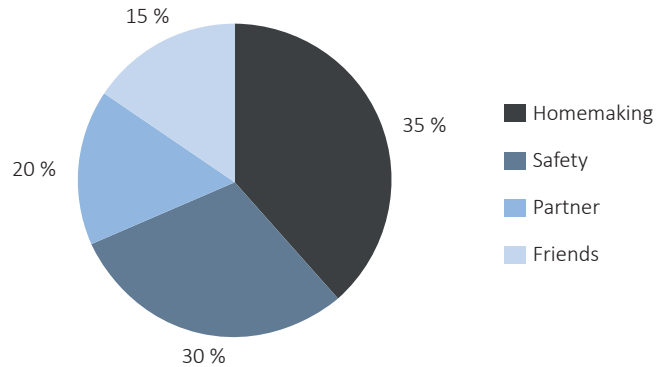


Figure 4: EVA Factors affecting the emotional value of your home

Keedwell, in his book *Headspace*, talks about the „Stamp of Personality“; how a person’s personality determines the way we live and design our home. Being able to express the own personality is an important component of identity. For example,

extroverts prefer busy and vibrant inner-city places to live, or prioritize social relationships over withdrawal and privacy. A study by Associate Professor Carl Matthews, of the School of Architecture at the University of Texas, dives deeper into this topic. Its findings indicate, in terms of interior design, that extroverts prefer direct access to spaces and less separation between public and private rooms. They also prioritize large window areas in the exterior façade to open the living space to the outside world. Bathrooms open to bedrooms and bedrooms open to living spaces. Introverts, on the other hand, tend to prefer enclosed spaces, more privacy and retreats. But his study differentiates even further between different character traits. Sensing, factual personalities, for instance, have a need for concrete information. They prefer order, symmetry and a grid-based

layout. Free thinking, intuitive personalities, on the other hand, like design to be more nuanced through patterns and textures such as concrete or wood. Thinking, logical personalities prefer a more rational, symmetrical design based on a grid. They tend to avoid open interiors. Empathic, feeling personalities, on the other hand, prefer open layouts, direct access, and have a drive toward social spaces because of their strong empathy and emotional intelligence. However, Matthews also points out that this study should be taken with a grain of salt, as it is not sufficient as a single medium to determine the ideal living space. Nevertheless, it indicates how personality traits can influence the perception of spaces (Keedwell, 2017).

A room that we enter or a façade that we look at immediately evokes an emotional response, even before sensory impressions can

be analyzed. Studies show that buildings made primarily of glass and steel, for instance, can affect our wellbeing and create a feeling of isolation (Nielsen, n.d.). Furthermore, room height plays an important factor in how a room is perceived. The minimum room height in Europe is 2.4 meters. However, people prefer more headroom, literally and figuratively. The psychologist and author John C. Baird published a study in the *Journal of Applied Psychology* about the ideal room height at home. According to this study, it is 3.04 meters, which is about 60 cm above the standard. However, rooms that are too high (for example, more than 2 stories) are perceived as rather negative, as they can make you feel exposed. In general, higher rooms are perceived as more beautiful, are more likely to be entered and appear more accessible. This can be particularly beneficial for ground floors,

which are often considered the least attractive floor (Keedwell, 2017). The premise that a space is perceived as beautiful is dependent on a positive emotional response. It is spaces that can be instantly grasped. Psychologist and author Antje Flade describes three characteristics of preferred and aesthetic environments.

**1. Coherence:** When individual parts make up a coherent whole, elements are related to each other and form a whole.

**2. Readability:** Environments are readable when it is easy to represent them cognitively. A spatially structured city is more readable than an unstructured one consisting only of uniform buildings. Readability fulfills the need for security and control.

**3. Complexity:** It is the number and variety of elements. The more numerous and diverse they are,

the higher the complexity. However, the balance should be appropriate to not overwhelm the viewer. Elements can be different colors, columns, different facades, windows and doors, ornaments, roof and building shapes. Trees and plants also add complexity to the environment and are thus perceived as more beautiful. Plain, uniform blocks of houses with no decoration are not complex and should be avoided (Flade, 2020) (Figure 5). The point of readability and complexity is also addressed by author and architecture critic Sarah W. Goldhagen in her book *Welcome to Your World*. She says that patterns and coherence support the readability of a building. Humans, because of their sensory cognitive system, are always on the search for repeating patterns in order to recognize a quick identification of basic shapes. This identification creates a sense of pleasure in the area of our

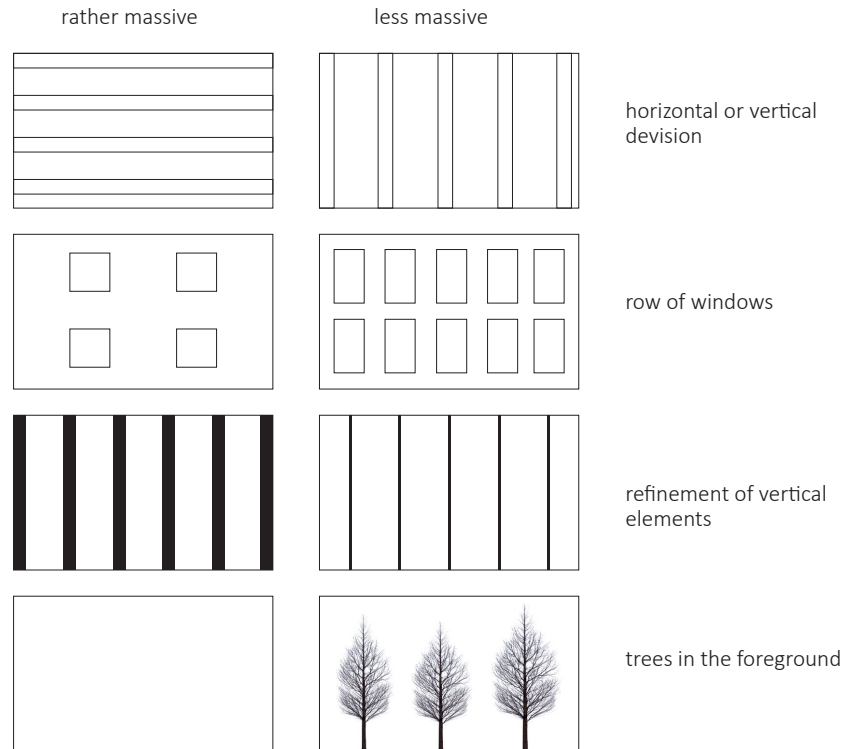


Figure 5: Reduction of the impression of massiveness

brains associated with our „sympathy“ system. Humans are naturally attracted to symmetry because it is satisfying, predictable, and navigable. The most important thing to humans is other humans, whose face and body shape are vertically symmetrical. It also describes that patterns without complexity are perceived as negative. Housing complexes with identical facades are therefore considered negative from a psychological point of view. Patterns must convey complexity. This can be derived from nature, which also conveys complexity and patterns (Figure 6).

In summary, architectural psychology can identify complex relationships that point a different perspective on the built environment and housing. How people respond to their living environment can provide an important design basis for architects to make buildings more engaging, aesthetically



Figure 6: Gaudí's Casa Batlló, Barcelona



pleasing and to create a sense of identity to their residents, often without additional costs.

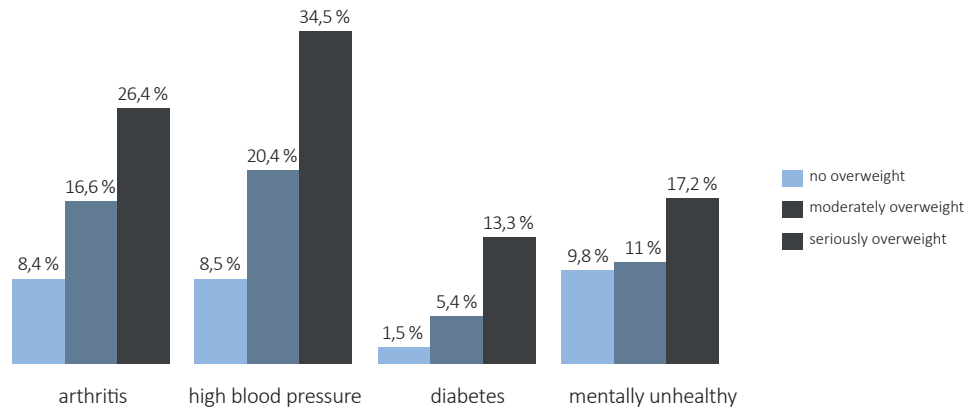
Regarding my own design project, these findings can help me to think about the effects that design solutions will have on the residents. The flexibility of floorplans and the complexity of the facade design can be a starting point for the design concept. Especially the findings on how to influence the identity of a home are valuable factors for my community driven design approach. However, it should be considered that the elements of flexibility react differently in the different tenures of owner-occupied houses and cooperative houses.

## IV. HEALTHY & ACTIVE ARCHITECTURE

### A. Stimulating physical and mental health

The following section addresses the health impact of buildings on people and explains concrete design principles on how active architecture can contribute to a healthy lifestyle. To start with, there has to be a differentiation between mental health and physical health. Physical health can be promoted through physical activity and a healthy diet. Architecture and cities can help to encourage people to be physically active and to provide a healthy living environment. However, mental health can only be influenced to a limited extent by concrete architectural means. The human psyche is very complex and profound. Mental conditions such as loneliness and depression can have various

causes and cannot be universally addressed. When people who feel lonely get into a room with other people, it can have a very helpful effect for some. For others, however, this situation can intensify feelings of loneliness. Contrary to what many think, communal areas or shared housing can have a counterproductive effect on social behavior. The „behavior setting“ expresses that the willingness to behave socially and to help others decreases, when too many people are present. None of them feels responsible, the so-called „diffusion of responsibility“. But not only the number of people is relevant, but also the type of people must be right in order to promote social interaction. People need control over social relationships. A loss of control, for example by too many unknown people, leads to social stress (Flade, 2020). That being said, architecture and cities may very well contribute



**Figure 11: Chronic disease and overweight**

no overweight, BMI < 25,0 kg/m<sup>2</sup>

moderately overweight, 25,0kgm<sup>2</sup> < BMI < 30,0 kg/m<sup>2</sup>

seriously overweight (obesity), BMI > 30,0 kg/m<sup>2</sup>

to overall wellbeing. As explained in the previous section, cities, buildings, and spaces influence emotions, behaviors, and wellbeing. These psychological factors, along with active design and healthy lifestyles, can indirectly contribute to overall positive mental health.

To make peoples lives healthier and more active there are two aspects that play a key role: First, external factors such as incorporating nature, for instance, can be brought into and around buildings to improve quality of life and health. Second, specific design principles of active design, such as using stairs instead of elevators, can promote physical activity.

## Healthy Environments

The World Health Organization recommends that cities provide 9 m<sup>2</sup> of green space per citizen.

However, many cities in Europe have difficulty implementing this due to their density. Several studies show that there is a correlation between a person's proximity to nature and their physical health and wellbeing. Furthermore, proximity to nature also promotes physical activity, social contacts and creates spaces for physical and mental recreation. Especially serious diseases such as heart disease, obesity and depression can be reduced. The positive effects of nature on health and wellbeing are numerous and sufficiently proven. Plants incorporated into the living space bring many benefits. They improve air quality, concentration levels, general wellbeing and job satisfaction. They also reduce irritation and stress and have a positive effect on productivity and creativity. But plants are not only beneficial indoors. A view of greenery also plays an important

role in daily wellbeing. All these mentioned benefits are also attained by looking into the green from inside the building (Hojniak & Hvid, 2021). Not only real nature has a positive effect on people, but also the imitation of nature through, for example, photographs, organic ornaments or even the color green. Stephanie Lichtefeld from the University of Munich studies experiments on the „green effect“. Green is associated with growth (physical and psychological) and promotes vitality and concentration (Keedwell, 2017). Cecil van Konijnendik, Professor of Urban Forestry at UBC, suggests a 3-30-300 rule: Everyone should be able to see 3 trees from home, have at least 30% tree canopy (or vegetation) in a neighborhood, and be no more than 300 meters from the nearest green space. However, it is not only the quantity, but more importantly the quality of the green space

that matters. It is not enough to plant only trees and green structures and elements. The quality is important and how the green space is perceived and experienced by the user. Care should be taken to use local and native species and plants with the best potential for the area. They can be stress reducing and provide a sense of social cohesion. However, in addition to green spaces, air quality is also of great importance. Air pollution is the biggest environmental health risk in Europe. This can be addressed in two ways. By transforming streets into pedestrian zones and bike lanes, and considering better ventilation of indoor spaces during the planning phase. Indoor spaces suffer far too often from poor ventilation and high CO<sub>2</sub> concentrations.

Light, whether natural or artificial, also contributes to overall health and affects people mentally and

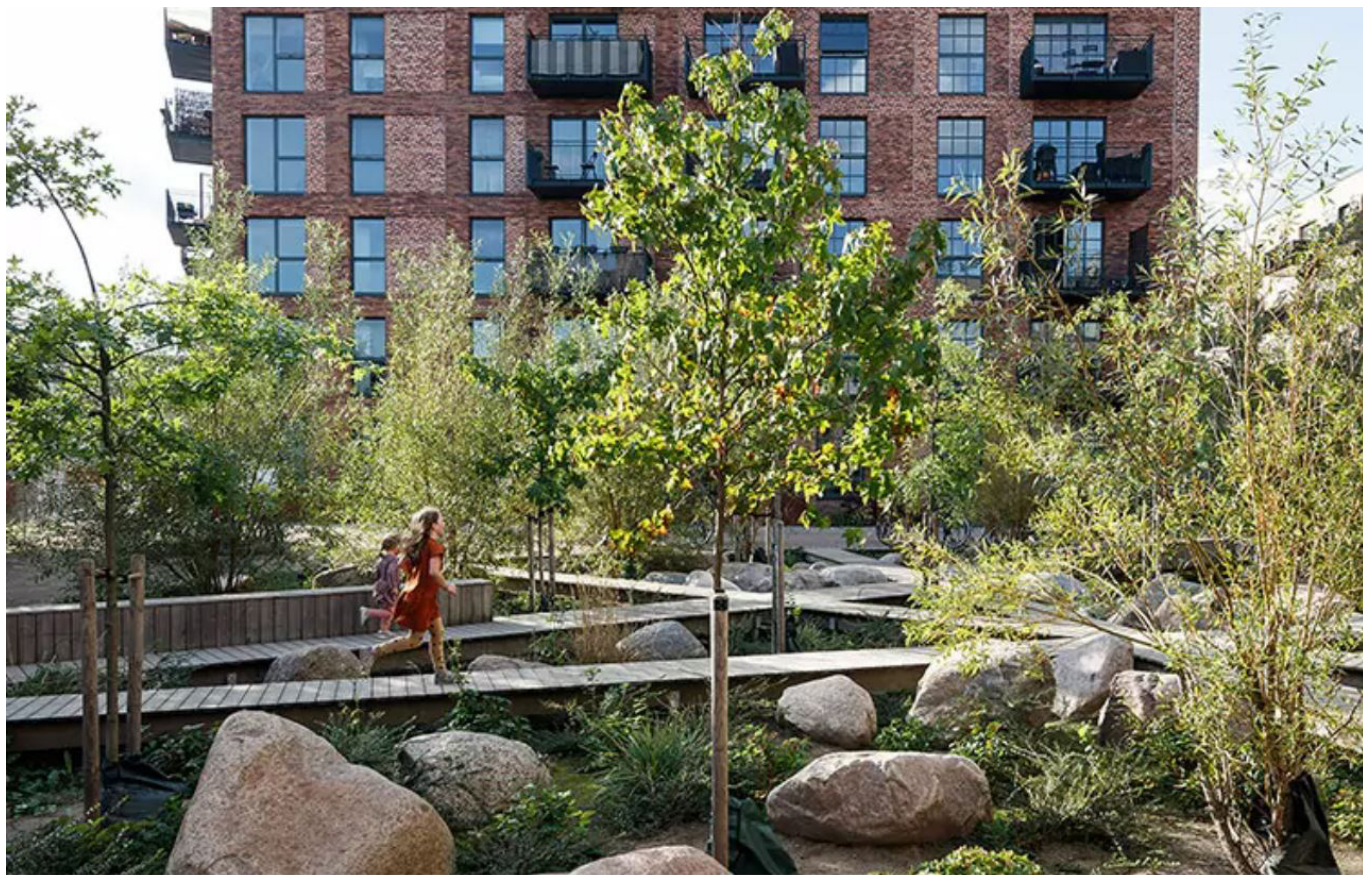


Figure 12: Gronttorvet, Copenhagen, Denmark. The green heart of the district, a park is created for the benefit of the residents.

physically. From an evolutionary perspective, humans are biologically wired by the natural light cycle. Special attention should be paid to provide interior spaces with enough daylight. Lastly, noise is also a major health risk. 113 million people suffer from harmful noise exposure in Europe, leading to 48,000 heart diseases and 12,000 premature deaths. 82 million citizens are exposed to road traffic noise of more than 55 decibels, which is the noise limit according to guidelines issued by the European Environment Agency EEA (Hojniak & Hvid, 2021). These basic aspects of healthy living are beneficial to both physical and mental health.

## Active Design

The topic of active design focuses on concrete structural aspects to positively influence the physical movement of the inhabitants. Spatial conditions play a significant role in the degree to which people move through the city and buildings. Physical activity adds years to life, reduces overweight, helps combat school dropouts, and leads to overall better performance, lower health care costs and absenteeism from work. The spread of infectious diseases decreased significantly between 1890 and 1937 in the Netherlands due to better housing conditions brought about by the Housing Act of 1901. Today, chronic diseases are the leading cause of death in the Netherlands. While life expectancy has steadily increased in recent decades, so has the amount of chronic diseases. According to the Harvard School of Public

Health, the negative impact of this development is significant for the healthcare system. Yet chronic diseases can be prevented by a different lifestyle and daily exercise. The most common causes are comfort, stress, poor diet and alcohol. The Dutch Standard of Healthy Exercise recommends at least 30 minutes of moderate exercise per day. Physical activity can be found and encouraged in the most insignificant daily routines. Active design must be based on human biology and psychological needs. According to Patrick Whitney, Dean of the Illinois Institute of Technology, active building design can be divided into two directions. 1. discourage passive behavior by making decision unattractive or unfavorable. 2. encouraging active behavior by making decisions attractive and favorable. For example, elevators can be placed in a less visible area to emphasize the use of the stairs. People



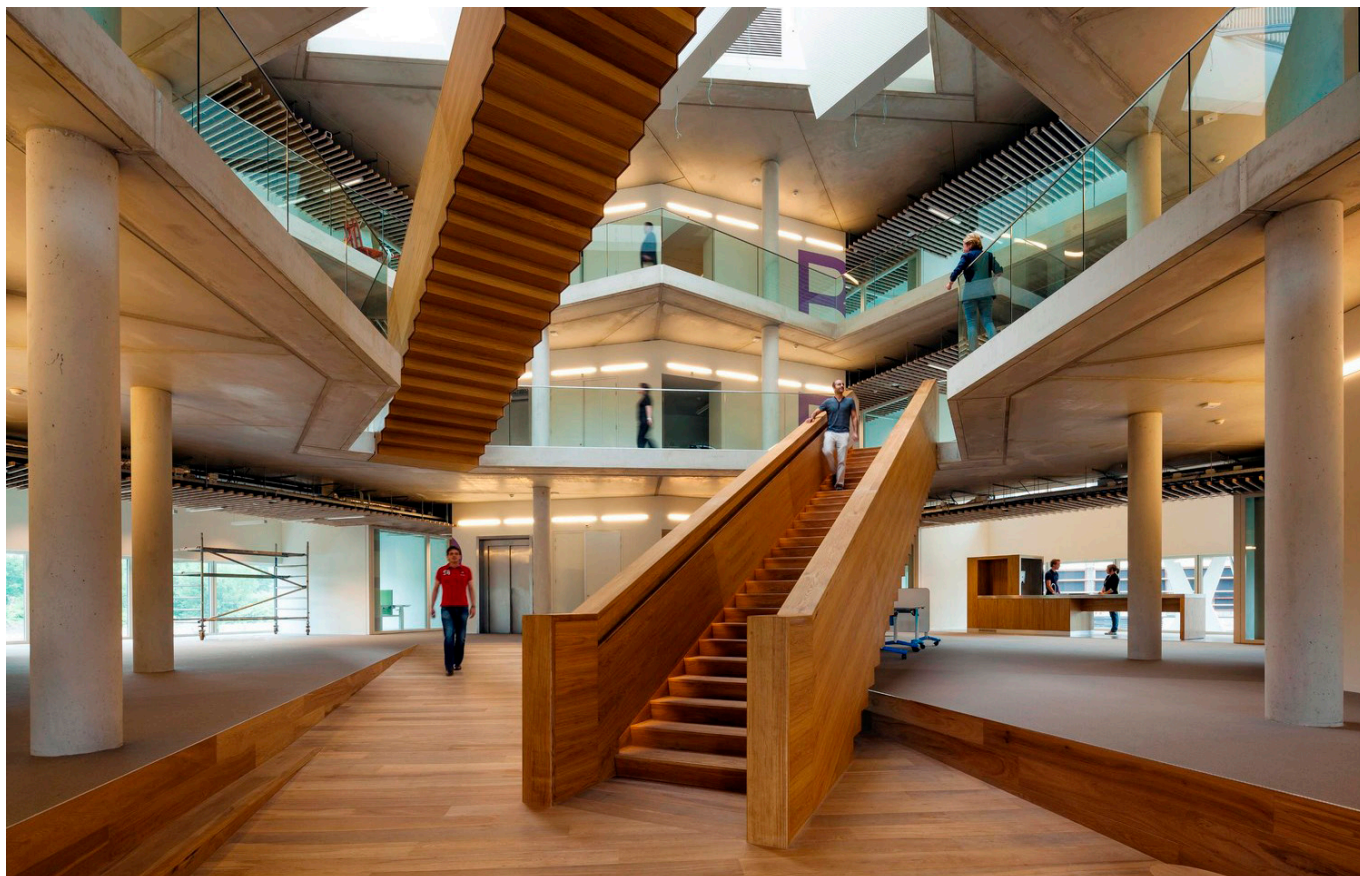


Figure 15: Highlighted, open stairs in the entrance, Tetra Office Building

are constantly weighing effort against efficiency. Laundry or work spaces can also be placed outside the apartment in the building to increase movement through the house and promote interactions between neighbours.

Access and circulation spaces such as stairs, corridors, elevators or ramps determine how people move through the building. Stairs can be attractively designed as a central point in the entrance for vertical circulation, while the elevator is placed in the background. The staircase must have aesthetic, spatial, and comfort qualities. Stairs can be opened up to the outdoors, or be designed with attention to detail. Corridors are often dull and can also be designed so that people have a positive experience when walking through them. This can be stimulated by a play of quality materials, transparency, (day) light, and spatial and

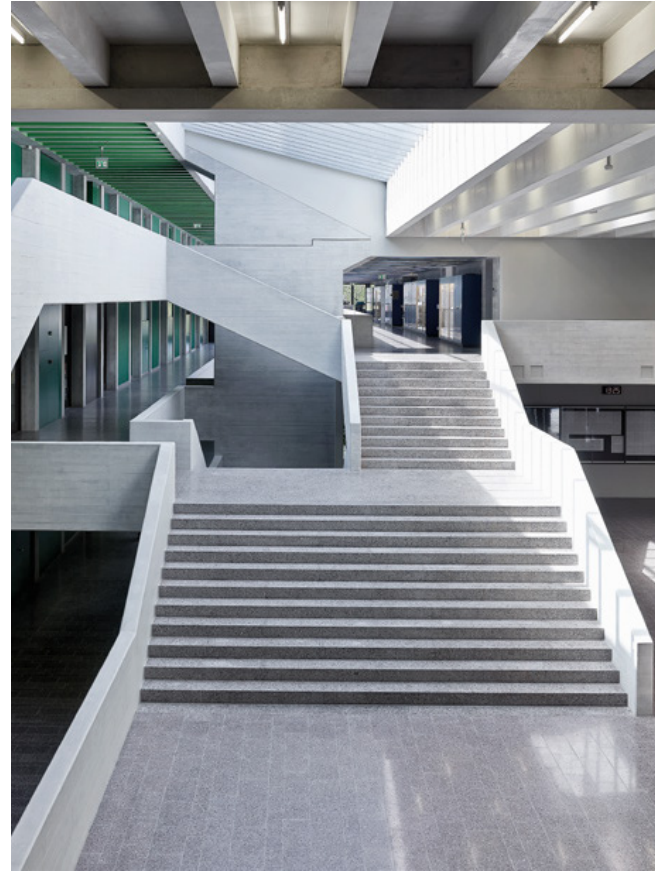


Figure 17: Spacious stairs with qualitative materials and daylighting



Figure 18: Designed hallway with colors, light and texture

programmatic differences. Split-level access points can also provide variety to increase movement (Department of Design and Construction et al., 2010). In addition, strategic destination points within a building can be placed to encourage movement between these areas. Building features directly related to physical activity, such as fitness, bike storage, or active office furniture can be integrated into the building. When placed so that they are visible, this can encourage movement by combining facilities and comfort related to physical activity. Courtyards should be easily accessible not only from the ground floor, through multiple access points and active landscaping, but should also provide a gathering place for residents. If possible, they should be semi-public to increase liveliness and encounters. Sports facilities, seating, plantings, and trees are beneficial for an active

courtyard. Buildings influence the immediate environment through massing, materials, degree of transparency, and programming. Wide, windy and anonymous spaces, as well as monotonous facades, are examples of how the walkability of an area is hindered. Buildings should offer different functions, multiple, attractive entrances and a pleasant human scale. Great emphasis should be placed on unique detailing at eye level of ground floors, entrances, and facades. Ground floors should be designed according to the „Eyes on the Street“ principle, that is, with a prevailing openness to enhance safety and security (BETA office for architecture and the city, 2016).





Figure 20: Apartment entrance hall, attractively designed with high ceiling and daylight. The stairs is present in the middle of the room.

## B. The Human Scale

The following section discusses the topic of human scale in cities and in architecture. More specifically, it deals with morphological and social issues, how cities and buildings can be planned in times of densification so that people can live (together) in a pleasant, healthy and active way. The following is an introduction to what human scale means exactly, followed by concrete (design) principles and how they can improve people's quality of life.

To begin with, it is necessary to define the concept of the „Human Scale“ in order to avoid misunderstandings and to be able to make a clear assertion. Human scale is an ambiguous term and it cannot be assumed that everyone understands the same by it. „Scale“ is interpreted by many as „size.“ For example, door openings, window heights, or

stair flights are designed to human scale and serve as a more technical indicator of spatial dimensions. In literature, however, human scale is defined in a different way. It includes many principles, which can be conceived differently depending on the author. For the social orientation of this thesis, the principles of architect and author Jan Gehl and David Sim are fundamental. They see the human scale in social issues and spatial forms in relation to the built environment and is strongly connected to environmental psychology. But also author Cliff Moughtin, Leon Krier or Jane Jacobs treat the issues of the human scale in their literatures mainly from social and spatial points of view (Mackesy-Buckley, 2012). To name an example of the human scale, public spaces are designed in a dimension, to allowing people to have visual contact with each other in order to see their faces and emotions and

thus increase the likelihood of communication with each other (Gehl & Koch, 2011). There is a strong relation to environmental psychology and active design, which is relevant as a complementary part in the topic of this thesis.

### Scale vs. size

Scale does not necessarily have to be considered in the size of a building. The Chrysler Building in New York, for example, is a large building in volume on the one hand, and is identified from afar by large, visual gestures such as the prominent roof peak. A distinctive detailing of the relatively small main entrance on the other hand, responds to the visual needs of pedestrians, and are only recognized in its immediate proximity (Figure 24). It is characterized from the small to the large scale. Similar to a tree, which forms a large whole with other trees.



Figure 25: Chrysler Building, New York



Figure 24: Entrance of the Chrysler Building with detailing on eye-level

The closer you step, the more you recognize its shape, its crown, the large branches, the twigs, the texture of the bark and finally the leaves and its leaf structure. Many modern buildings look interesting in their outward form, but the closer you get to them, the less detail there is to engage with. A lack of detail and elements communicates a detachment between people and buildings. The human scale needs to be represented in different levels and should relate to the human form (Donnelly & Morales, 2016).

### Building height

In relation to social aspects, and similar to Active Design in residential architecture, a building should respond to a person's biology. The human field of view is aligned horizontally, where we can see very little above and a little more below. This



comes from an evolutionary perspective where we had to watch rather downwards than upwards. The field of view affects how we perceive the height of buildings. The closer you stand to a building, the less you can see what is happening on the upper floors; you have no connection to this area. Only when you step into the distance you can see what is happening on the upper floors. This increases the distance to the building, which means that there is no connection and communication happening. Communication from the street can perfectly take place up to the 1st and 2nd floors, and is still possible up to the 3rd, 4th and 5th floors, as the connection to the street is still strong and details such as faces and gestures can be recognized. Floors above that have little to no connection to the street (Gehl & Rogers, 2010). Up to the 5th floor, you can still participate in city

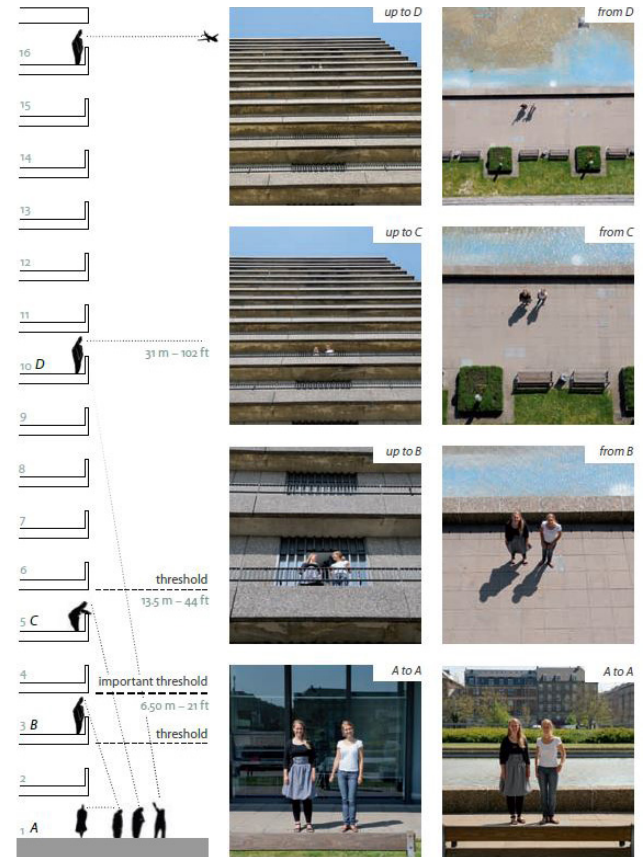


Figure 28: Visual connection between streetlevel and different floor heights

life, calling out to children playing in the backyard or calling out to someone you know. In addition, most people can walk up 3 to 4 stories without effort. In addition to physical activity, stairwells can also function as social forums where neighbors can meet. Low-rise buildings reduce the number of apartments and households, giving residents more social control and making it easier for intimate situations to arise. As learned from chapter three Solutions to contemporary housing issues, social control in the home is essential in getting to meet your neighbours. The likelihood of knowing your neighbors increases when you live in a low-rise building, rather than a high-rise. The staircase is a valuable buffer zone between the outside world and private living space and functions similarly to a gated community, with the advantage that this space is not isolated from the city (Gehl, 2019).

## Walkability

To encourage active and social street life, buildings and neighborhoods must be designed to promote walkability. The likelihood that people will communicate and engage in social activity increases with the frequency with which they go outside. Walkability is the starting point from which many other activities emerge: Street trading, window shopping, short stops, longer stays, conversations and meetings, sports, recreation, children playing and so on (Gehl & Rogers, 2010). Social activities require the presence of other people. In this regard, the space should not be solely for foot traffic, but must appeal to people's senses to encourage them to walk and communicate with their surroundings. This can be done in a variety of ways. Following the principle of Sven-Ingvar Andersson, professor of landscaping at the school of Architecture, Royal



Figure 30: Dinan, France. Active groundfloors and narrow streets make places seem more lively





Figure 31: Residential street in Haarlem with active street life and a small dimension. Emotions and details can be easily recognized

Danish Academy of Art, „Make spaces smaller than necessary“ will make public spaces and streets appear more alive. This way, building details and other people in the environment and their facial expressions can be recognized. Experiences become more intense. The environment is perceived as warm, personal and welcoming. In urban areas with large buildings, wide streets and squares, there is little to experience. These places often seem empty, impersonal, formal and detached.

### Mix of users and functions

However, density alone does not simultaneously lead to a vibrant city. A city becomes vibrant when there is quality urban space and a critical mass of people who want to use that space. Attention to the smallest scale at eye level is most important to promote active street life (Gehl & Rogers,

2010). Density, different building types and the uses from the same places creates good urban qualities. Architectural diversity provides constant stimulus and information and conveys a pleasantly complex environment. Different, even opposing users and uses can very well coexist as long as the neighborhood provides a suitable space. The example of the Cross Section of Parisian houses around 1850 was meant to express the miseries of society and to represent the economic segregation of classes (Figure 32). However, it can be seen in another way: It is impressive that all these people share the same address, they are neighbors, and once they enter the street they are all part of the same community and have equal access to the commons of the city. Comparing this heterogeneous mix of different classes of society to a forest, a broad mix of different plants and trees

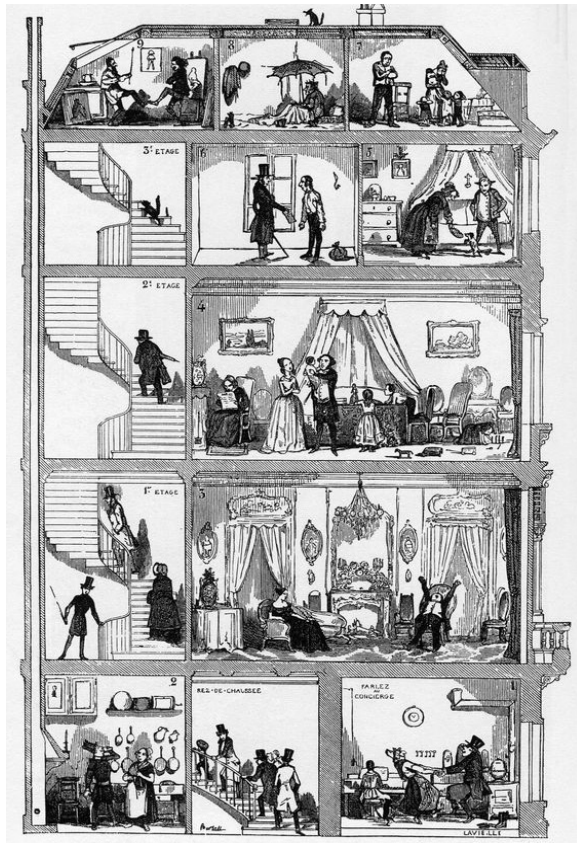


Figure 32 : Cross section of a Parisian house about 1850 showing the economic status of tenants varying by floors

leads to a biodiverse complexity at different levels, which makes the forest healthy and resistant to diseases, storms or fires. A shared identity with a community comes from sharing the same places and resources. Local identity is often stronger and more important than national, cultural, or ethical identity and is a healthy form of collective identity (Gehl & Koch, 2011).

### Parcelling & control

Different parcels in a building block can be developed and managed independently, offering greater flexibility in building design, typology, construction, tenure, use, and development over time. But this independence is not just a matter of form or design. Individual owners can make their own decisions about the development of the building in terms of ownership, rental, commercial use, subletting and so on.

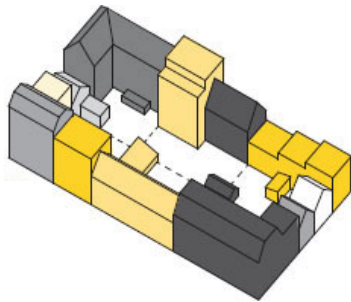


Figure 34: The system of joining up and juxtaposing allows diversity in each block



Figure 35: Individualised building block creates diversity in architecture, function and users and increases the level of control with individuals

## Layering

Furthermore, buildings can be designed in layers to place different functions and typologies on top of each other. The difference between layering and stacking is that in stacking, mainly the same functions and types are placed on top of each other. Ideally, urban buildings should be differentiated into layers to characterize the functions and emphasize the advantages of each floor. The ground floor has direct visual contact with the street and can have a positive impact on function and promote street life. They are very flexible in their use, can be extended to the outside and are easily accessible. An open ground floor with visual connection to the outside enhances the „eyes on the street“ principle and increases security. Next to stores, ground floors can also contain apartments, workspaces or other service functions.

The upper floors have close contact with the street, yet privacy and security. They differentiate themselves in how they are accessed by stairwells and more daylight. The top floor is often seen as attractive because it gets more daylight from all sides, has better views, and the floor plan can vary greatly because there are no load-bearing walls. Often the prices are higher, making them popular for penthouses. This increases the social-economic diversity and dynamism of the building. Medium height buildings have a greater advantage

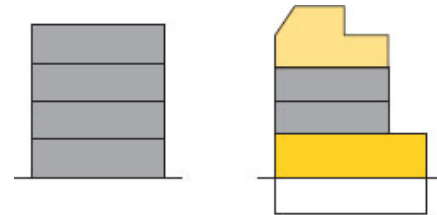


Figure 36: Stacking vs Layering





Figure 38: Principle of layering, Nya Hovås, Gothenburg, Sweden

in layering than tall buildings because the first floor and attic have proportionally more floor area. Together they often make up half of the volume, increasing the economic value of the building (Sim & Gehl, 2019).

### Conclusion

In conclusion, the principles of the Human Scale is comprehensive and can essentially build on the findings of previous chapters such as *Architectural Psychology* and *Active & Healthy Design* in a complementary way. Especially the detailed and spatial dimensions and the small scale are one of the main factors of my design concept which contribute to an active life and thus create a socially equitable design proposal. The built environment responds to the biological needs of people by stimulating their senses.

## V. ARCHITECTURAL SOLUTIONS ON THE EXAMPLE OF CASE STUDIES

### Case Study 1: Lokdepot, Berlin

<b>Project Name:</b>	Lokdepot
<b>Location:</b>	Berlin- Schöneberg
<b>Architect:</b>	Robertneun
<b>Year of realization:</b>	2012- 2016
<b>Client:</b>	UTB GmbH
<b>Plot size:</b>	21.000 m <sup>2</sup>

#### Abstract

The Lokdepot is an urban development and includes high quality freehold apartments. The project includes different building typologies for a wide range of different users. The main concept of these buildings is the open layout of the apartments, which can be freely and individually

designed by the residents (Kleilein, 2014). The reason for choosing this project is precisely this aspect, which offers a collective urban living, with the concept of individualization of the own living space. The advantages of self-control, free expression in the own living space and the mixture of different users have been studied in this research. These themes will be exemplified by the Lokdepot as to how such concepts can be implemented architecturally. Another aspect for the choice of this project is the morphology, together with the individual typologies and the proximity to the train tracks, which has strong similarities with my individual design project and thus creates a link between research and design.



Figure 39: Street front of the Lokdepot

## Urban morphology

The building complex was created as a completion of the building block on a formerly derelict plot of land. The incomplete block was closed with a series of building volumes lining up lengthwise the block and the traintracks (Kleilein, 2014). The typical Berlin back houses were omitted in order to obtain a collectively usable backyard, which is assigned to the individual buildings parcels. The challenge was to develop an inner-city residential concept along the busy train tracks as a reconfiguration of the site while retaining its atmospheric charm

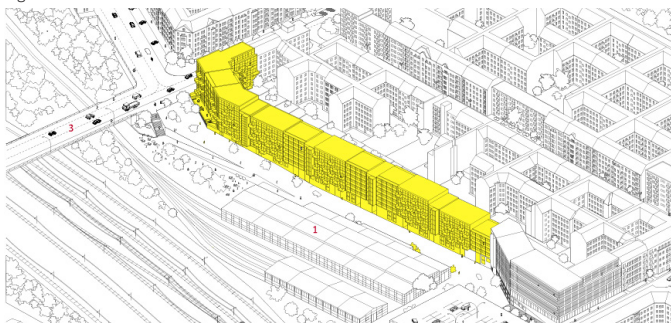
of the historic lokdepot. The project thus acts as an urban edge, differentiating private space from public space. Due to the sloping topography of the site, which varies in height, the ground floor is used as a kind of „urban plinth“ for commercial use (Figure 42). The living space is located above. A coherence of the different looking typologies is attained through the materialization of red colored concrete and red metal panels. The red color is a reference to the rust-red tracks that characterize the landscape along the building (BauNetz, 2019).








Figure 40: Areal view

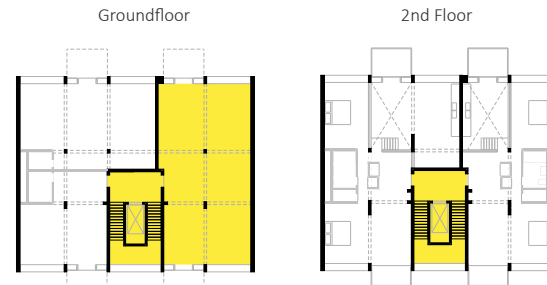
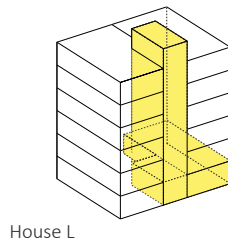


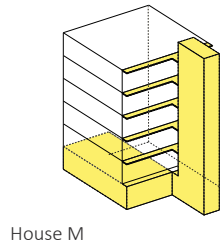
## Circulation

The circulation space is the space within a building that serves the movement of people and from which access is provided to apartments and other spaces. Since the circulation space is mainly used by residents, encounters between residents often occur there. In the Lokdepot, great attention was paid to the entrances, as they not only provide access to the apartments, but also connect the public outdoor space with the collective backyard.

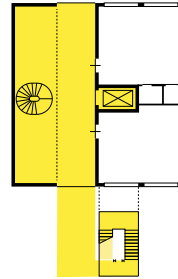
Entrance spaces are sized in a dimension to provide space for activities such as neighborhood gatherings, children playing, or simply a short conversation to neighbors. The exterior staircase of House M increases the floorspace of the apartments and is specifically intended to function as a communication space between residents and to the courtyard (Die rote Wohnfabrik | BDA | der architekt, 2016).

 Circulation space

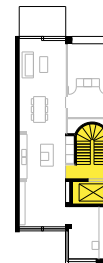
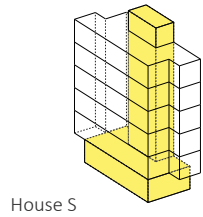
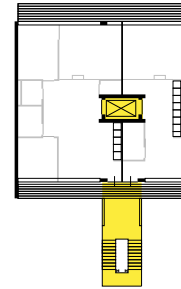




Groundfloor



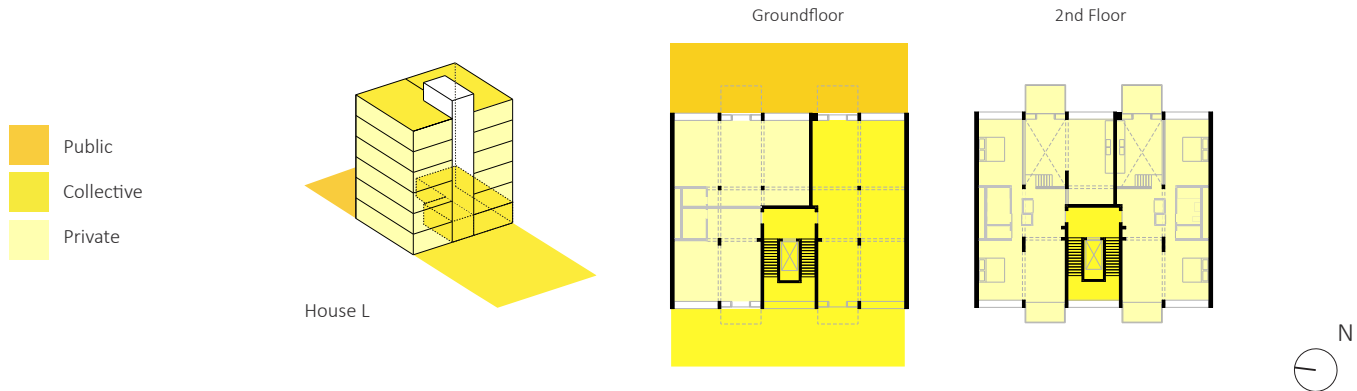
2nd Floor



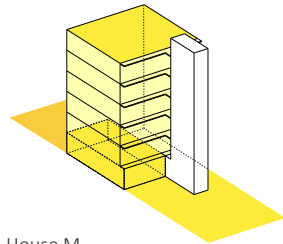
## Private, Public, Collective

A distinction between private, public and collective spaces is important for a clear differentiation and design of spaces and to meet the urban needs of public and community life, as well as for withdrawal. The Lokdepot forms a clear division between the public street space and the collective area, which is available to the residents through the shared backyard, the large entrance areas, as well as the

collective roof gardens. The apartment buildings have collective gardens and are referred to as „courtyard gardens“. It provides an appropriate frame for building a community within the building. (Die rote Wohnfabrik | BDA | der architekt, 2016). The private living area is located above the ground floor and as such is visually and spatially separated from the semi-public ground floor (Buschmann).

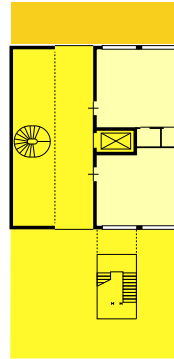




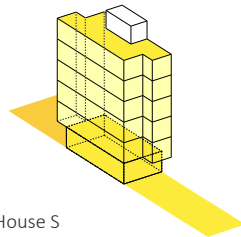
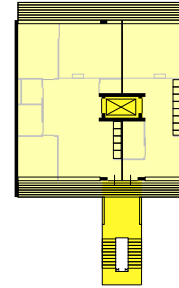


House M

Groundfloor



2nd Floor



House S



## Case Study 2: Superlofts, Amsterdam

<b>Project Name:</b>	Superlofts
<b>Location:</b>	Amsterdam, Houthavens
<b>Architect:</b>	Marc Koehler
<b>Year of realization:</b>	2016
<b>Client:</b>	Era Contour BV
<b>Plot size:</b>	18.000 m <sup>2</sup>

### Abstract

Superlofts is an architectural development where the residents are involved in the design project from the very beginning. It is a co-housing project that is financed by the residents and the architects association itself. Thus, there is no developer aiming for profits. This allows the residents to co-design the concept, the living space and the

facade, creating a strong community and a sense of belonging (arqa.editorial, 2019). Designed like an „urban village“, the issue of loneliness and isolation is addressed through communal and hybrid spaces (N.S. Program, 2018). The project targets a community of people with creative and entrepreneurial mindsets who live hybrid lifestyles with specific spatial requirements. The apartments are based on an open floor plan principle, with multiple shafts to ensure maximum freedom of the dwelling design. The architects have designed each apartment together with the residents and can be developed gradually (MKA, n.d.). For this reason, I chose the Superlofts as a case study. Similar to the Lokdepot, the Superlofts concept emphasizes free development and freedom for the residents.



Figure 62: Street front of the Superlofts

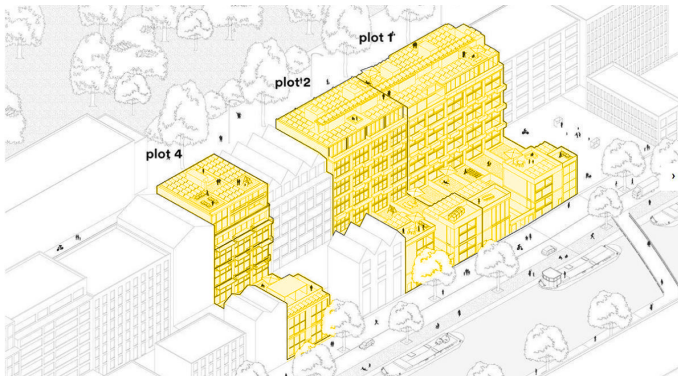
## Urban morphology

Three building volumes (Plot 1, 2 & 4) form a segment of the building series and are part of a large urban development in Amsterdam Houthavens. The building volumes each consist of an apartment building of 30 meters height, and opposite townhouses of 12 meters height. Between them on the first floor is a courtyard situation, which is used by the adjacent buildings as collective gardens. Below the gardens on the

groundfloor are parking garages and storage space, and are also used collectively (MKA, n.d.). The morphology of the project resembles a typical Dutch narrow building block, which is permeable on one side through lower buildings and openings, providing the courtyard with sufficient daylight. This increases the quality of this space as a place to stay and can efficiently function as a private refuge.




Figure 63: Areal view

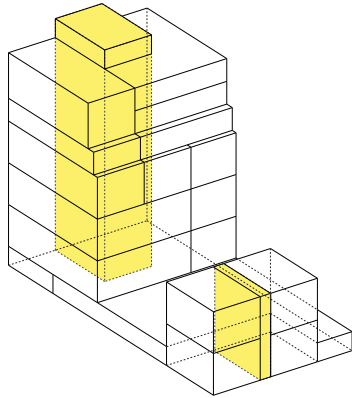


## Circulation

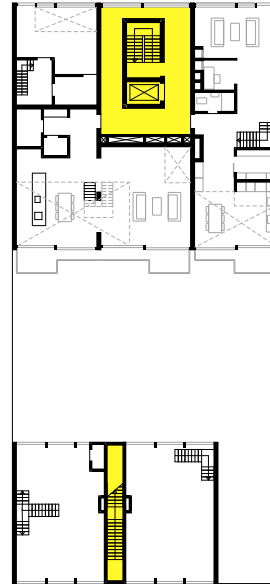
As such, the circulation space in the Superloft is designed to be very efficient and simple. The stair core, as mentioned earlier, is located at the exterior facade to create an efficient apartment layout and provide natural daylight to the circulation space. Due to the apartment building's height of 30 meters and 10 floors, the access is mainly provided by the elevator (MKA, n.d.). The stairwell itself is closed off from natural daylight and serves purely functional purposes. Casual encounters take place mostly in the elevator, or on the floor

level to its direct neighbors in the hallway. The access to the townhouses is also purely functional. Due to the low height of the townhouses, access is provided solely via the staircase and connects to two additional apartments on the upper floor. From personal observation from a field visit, the potential to use the stair space as a potential collective space by emphasizing encounters was hardly used. This aspect is different from the circulation spaces in the Lokdepot, which connects the access with collective spaces.

 Circulation Space



1st floor



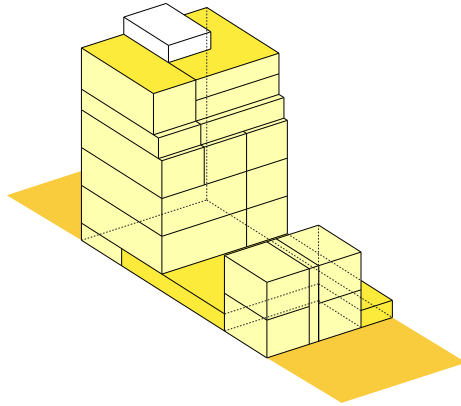
## Private, Public, Collective

The concept of the „urban village“ is largely obtained through the co-housing concept, as the residents organize themselves collectively and design concepts together. This provides a framework for residents to get to know each other and to network and come together (Melvin, 2020). An urban village in a dense development as in the example of the Superloft can only spread little in width, and much more in height. Some collective spaces are present in the project and offer the possibility of networking and coming together. Collective spaces include the rooftop terrace and the elevated courtyard, which according to the architect is intended as a space for all residents. However, from my research, floor plans and diagrams, and from my site visit, it was not

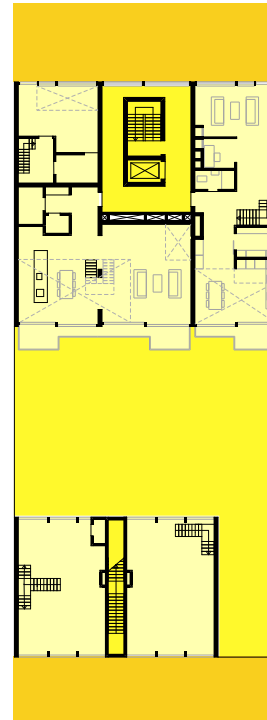
apparent to me how the courtyard is collectively used and can be accessed from different floors. The roof terrace provides a space for gatherings. However, this space has to be actively entered and as such is hardly attractive architecturally or through planting. It offers little incentive to be used permanently. The quality focus of the superlofts is clearly on the private living areas and the free and qualitative design possibilities of the residents. Likewise, the public street space is seen as an extension of the living space by the ground floor apartments especially by the townhouses and its southern orientation. This became apparent during the site visit in the lush planting and furniture along the facade, and the way the living space and the public street space are interchanged.



- Public
- Collective
- Private



1st floor



## Case Study 3: Spreefeld, Berlin

<b>Project Name:</b>	Spreefeld
<b>Location:</b>	Berlin- Kreuzberg
<b>Architect:</b>	Fatkoehl Architekten, BARArchitekten & Carpaneto Schöningh
<b>Year of realization:</b>	2011-2013
<b>Client:</b>	Genossenschaft Spreefeld
<b>Plot size:</b>	7.400 m <sup>2</sup>

### Abstract

The Spreefeld project in the inner-city of Berlin is a cooperative housing development with the main focus on the community. Similar to the Superloft, the Spreefeld does not have a developer, but is financed by a community of future residents and

the housing cooperative and was designed together with three architecture firms. The focus was less on the individual residential units, but much more on how a community can be architecturally designed (Bau- und Wohngenossenschaft Spreefeld Berlin eG, n.d.). Different types of apartments such as the cluster housing and the standard private apartments are designed to accommodate a broad mix of different users with different financial resources. Through the cooperative concept even people with low income can live in the Spreefeld. Furthermore, the focus was on the public and collective ground floor, which can be used for commercial and especially for collective purposes (Balhausen & Kleilein, 2014).



Figure 88: Areal view

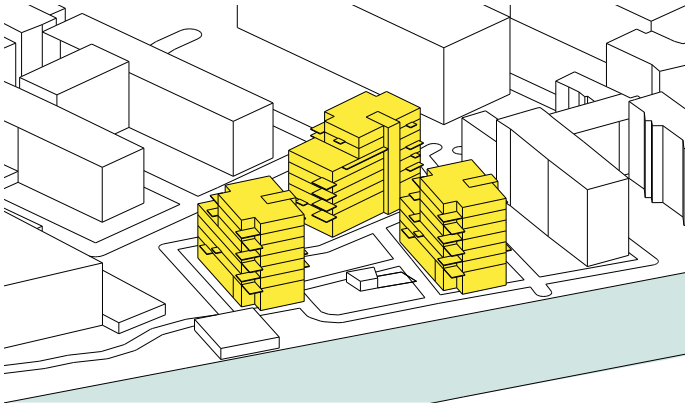
## Urban morphology

The project consists of three building volumes that are arranged offset to each other and form a central space between the buildings. The architects paid attention to an open structure in order to leave the site and the riverbank of the Spree accessible to the public and to allow almost every resident a view of the river. As a result, there is no clearly defined front and back, but instead forms a flowing urban space. In addition, the riverbank is to the north and the sun is to the south. So it's

not entirely clear which side is the more attractive one. The architects and the cooperative saw the project as an urban extension, which meant that the public should not be excluded. The buildings consist of six stories, each with a community roof terrace and private vertical gardens. The roof terraces were seen as a compensation for the residents, as the inner area and the waterfront remain open to the public (Balhausen & Kleilein, 2014).

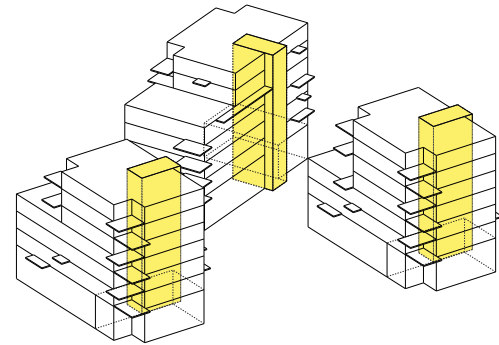


Figure 89: Waterfront

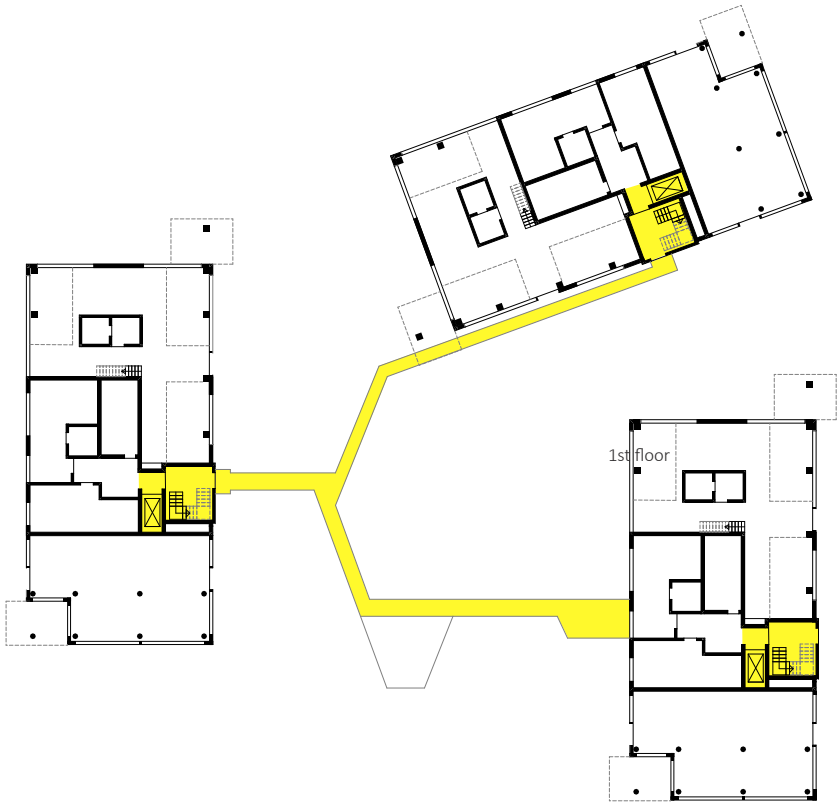


## Circulation

The circulation space in the Spreefeld is efficiently designed and serves the main function of the access. The stairwells are opened up to the outdoors and partly extend outside the building. The reason for this is, on the one hand, the fire safety regulations, as the open structure counts as an outside staircase (Balhausen & Kleilein, 2014). On the other hand, the staircase is designed to be of high quality and to connect the staircase with the surrounding nature. Thereby the spatial quality should be increased to promote encounters among residents. Furthermore, the stairs are connected to the roof gardens and can be reached via a gallery access. A walkway spans between the three building volumes and connects the central winter garden.



 Circulation Space

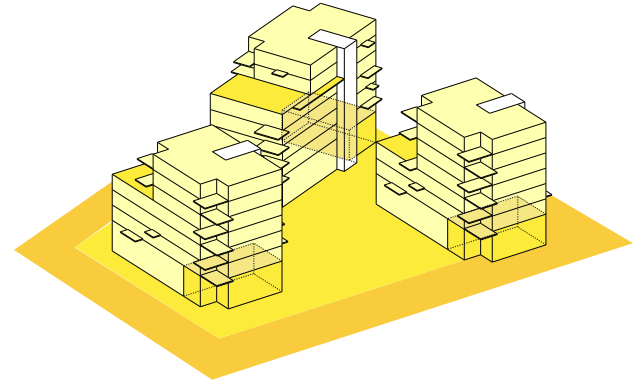





## Private, Public, Collective

The focus of the cooperative was on the inclusion of the public to the river bank, as well as the permeability and accessibility of the property. Accordingly, the collective areas are very large compared to the Lokdepot and the Superloft. The central courtyard mainly serves the residents and functions as a multifunctional space for various activities such as playing, gathering, gardening or relaxing. In addition, each of the three buildings has so-called „option rooms“ in the groundfloors and were deliberately not assigned to any specific function. The architects left these spaces largely un-designed to allow spontaneous adaptations by the residents to organically happen. They are used collectively by the residents or can be rented by outside parties as long as they are not used exclusively for profits and retail space. The entire

ground floor does not include a residential function, but remain open to the collective and the public. Thus, there are office spaces, a carpentry and workshops, which can be used by the residents, or studios and commercial spaces. The private living spaces are located above the ground floor. The three roof gardens are exclusively accessible to the residents and can be freely cultivated and utilized by them (Sánchez, 2021).



 Circulation Space



## VI. CONCLUSION

The goal of this research was first to find out how architecture creates the framework for healthy and active living and how residents can better interact with each other through design principles. Second, it was to find out how to create and strengthen a community and a sense of belonging in mid-rise residential architecture. Based on extensive literature research on the main topics of psychology and healthy living, and analysis of case studies, a clear conclusion can be drawn. The result of the first point is that physical health in particular can be influenced by architectural and spatial design aspects. An increase in physical activity can be achieved in simple daily movement patterns, and has a positive effect not only

on general health, but also on the overall wellbeing. This can be achieved, among other things, through attractive and strategic design of circulation space and common areas, and the implementation of nature, healthy materials and a strong connection between inside and outside. The aspect that active design has on mental health can only be answered to a limited extent. Due to the complexity of factors influencing mental health, a universal, architectural solution is not feasible. Promoting health and general wellbeing, as well as a healthy and friendly living environment and creating a sense of community, can have a positive effect on the psyche for many. However, social issues such as loneliness or stress cannot be counteracted across the board for everyone through positive influences of the living environment, which means that the effect of active design on mental

health is only indirect. The creation and design of collective spaces within a housing complex can provide the framework for residents to interact with each other and form a sense of cohesion. However, quality and lasting interaction requires the willingness of residents, making spatial influence on social interactions also indirect.

The result of the second point shows that the formation of a community within a housing complex is not only influenced by spatial structures, but largely by the housing tenure. Thus, especially through the analysis of the case studies in the comparison between owner-occupied apartments and housing cooperatives, it becomes apparent that a strong sense of community among residents and the prevention of loneliness must be actively organized and should go beyond random encounters in collective areas. However, regardless

of the housing tenure, a qualitative spatial design of the collective areas can help to promote encounters between residents and invite them to linger. That people can identify with their living environment and develop a sense of belonging is strongly favored by a sense of community. However, residents also need control over their living space, which can be provided through adaptive design and making spatial adjustments possible for the residents. The design and appearance of a building can be identity-building if it reflects the psychological and biological needs of the occupant.

My key takeaway from this research is the psychological impact that architecture has on the user, mainly subconsciously, and what profound effects take place on the psyche, behavior, emotions, or wellbeing. Buildings not only define the appearance of a city and a neighbourhood, but

also influence us in many different ways. Creating architecture with a strong identity has a positive impact on social coexistence and an active urban life and is not only based on aesthetic or subjective views, but can be scientifically-psychologically substantiated. The findings of this thesis will greatly shape my attitude towards residential architecture and my own design projects, and make me even more aware of my responsibility as an architect.

Based on these findings, urban and architectural designers should consider that their designs do not merely have a superficial effect on urban and private life, but have a profound impact on the quality of life and on the development of users and neighborhoods. From the learned insights of this thesis, it can be assumed that architects have not only the opportunity but also the responsibility to

design buildings that can sustainably satisfy the needs of users and promote active, urban living. This research is aimed to provide insight into the interrelationships of architectural psychology, which is little known in today's building industry. Ultimately, the Scientific Psychology approach to residential architecture can lead to a better understanding of how people respond to their environment and can explain behavioral patterns that can be considered in the design process.







An aerial photograph of a city grid, overlaid with a semi-transparent orange filter. The image shows a dense network of streets and buildings, with a prominent circular intersection in the lower-left quadrant. The text '02 Urban Masterplan' is centered in the upper half of the image.

# 02 Urban Masterplan



## Project Location - Rotterdam-Blijdorp









## Project Location - Rotterdam-Blijdorp







## Existing Situation

The centrally located site of Walenburghof in Rotterdam-Blijdorp is characterized by two busy streets and a large intersection, separating the site in two parts and occupying the urban space by large car infrastructure. The heterogeneous building types are occupied by conflicting functions such as a car-rental, colleges and elderly homes, creating friction between the different user groups. The urban spaces are mainly wide, open and undefined, lacking clear orientation and use options for pedestrians and residents. The studio's task was to turn the site of Walenburghof into a liveable, qualitative and friendly neighbourhood.

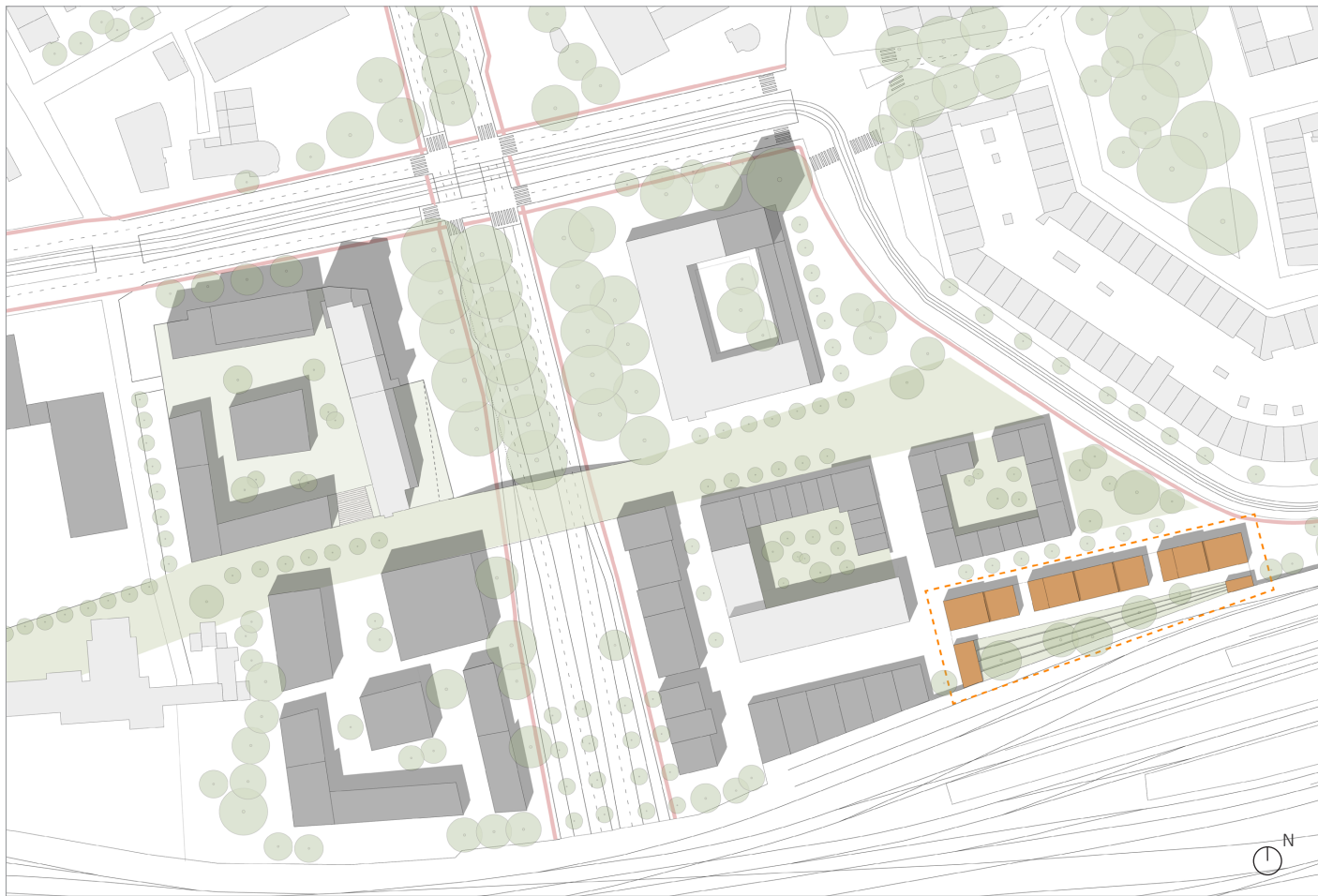




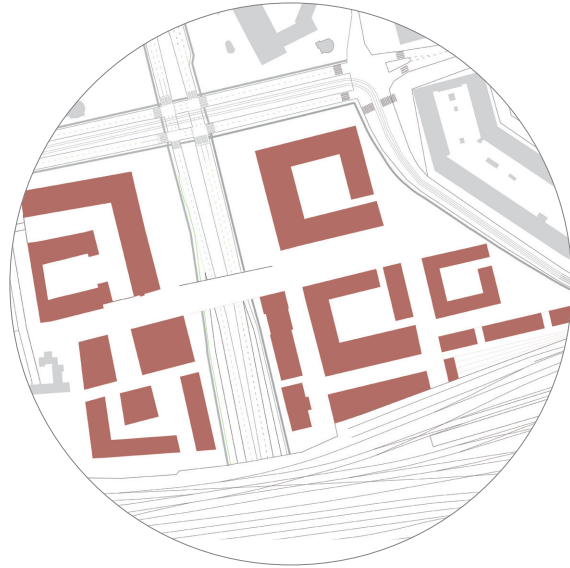
## Masterplan Proposal

The groups masterplan responds to the challenges with four ambitions: creating a neighborhood center, providing social sustainability through cooperative housing tenure, providing healthy living conditions and adapting urban morphologies to the human scale.

The northeast area of the master plan serves as a neighborhood center with commercial spaces and public facilities. In the middle, a new pedestrian bridge connects the west and the east of Walenburghof over the Statenweg and continues as a planted promenade. The new housing development responds to the building scale of the existing Blijdorp neighborhood: low- to midrise buildings and a small-scale urban layout define public streets and private backsides. The mix of housing and tenure types, functions and typologies cater to different age and income groups, thus offering the grounds for a socially inclusive living environment.



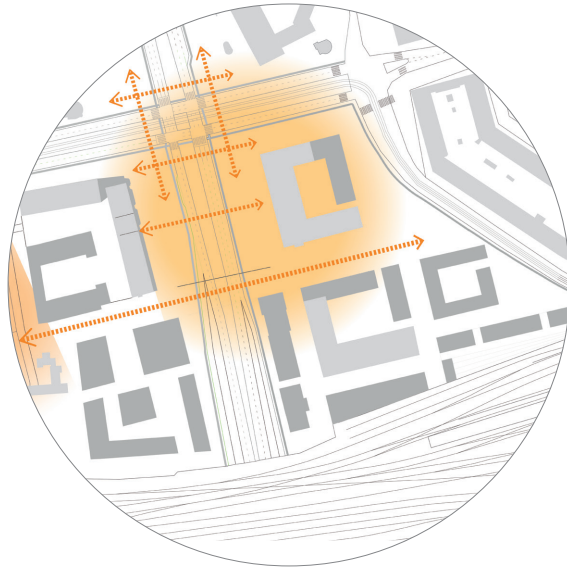
## Masterplan Ambitions



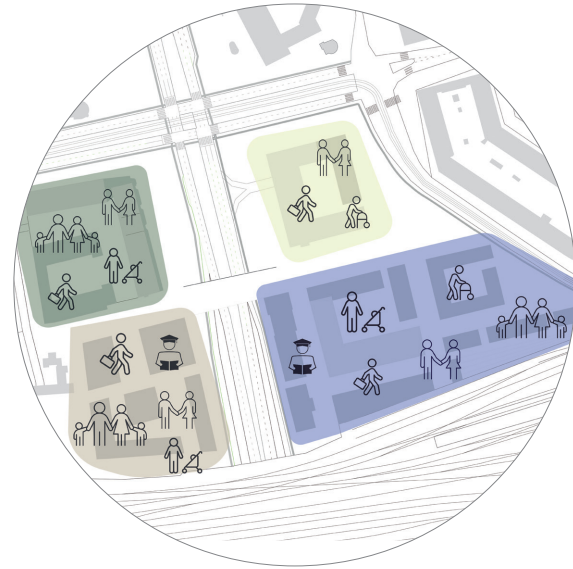
Establish a defined urban fabric through low-to midrise buildings



Make a green connection & narrow down the busy road



Establish a neighbourhood center & improve accessibility to the area



Create a wide social mix through a variety of tenures and typologies

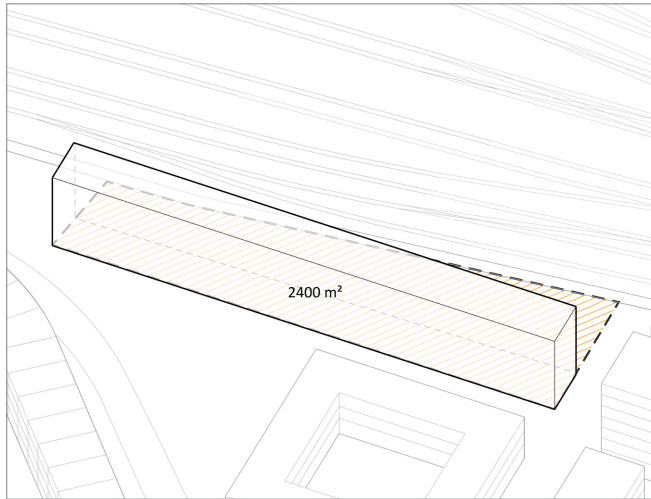




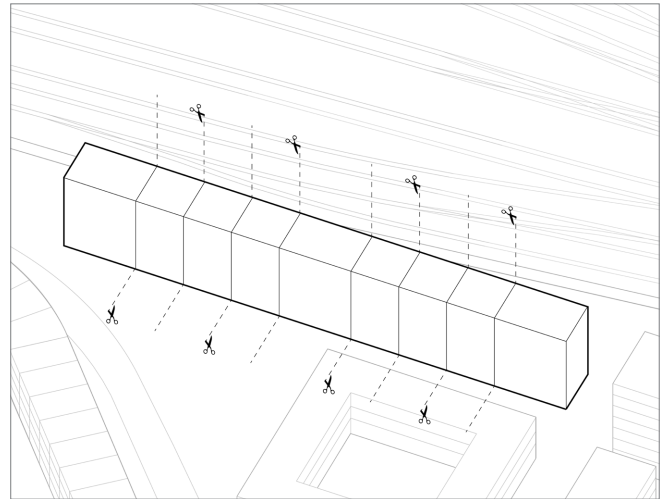
An aerial photograph of a city grid, overlaid with a semi-transparent orange filter. The image shows a dense network of streets and buildings, with a prominent circular intersection in the lower-left quadrant. The text '03 Design Concept' is centered in the upper half of the image.

# 03 Design Concept

# Project Development

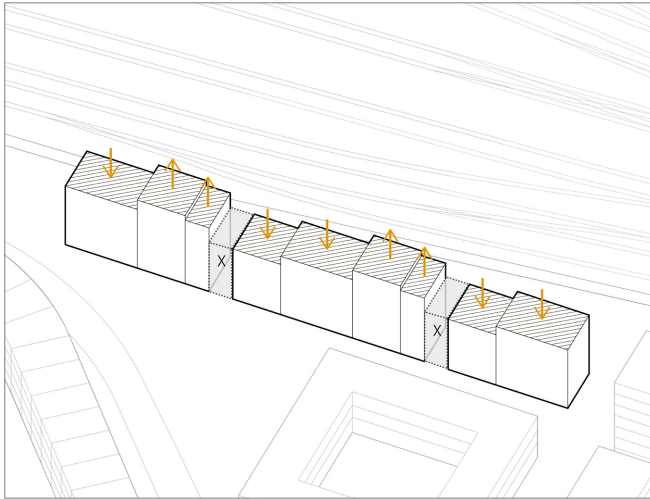


Site & building volume

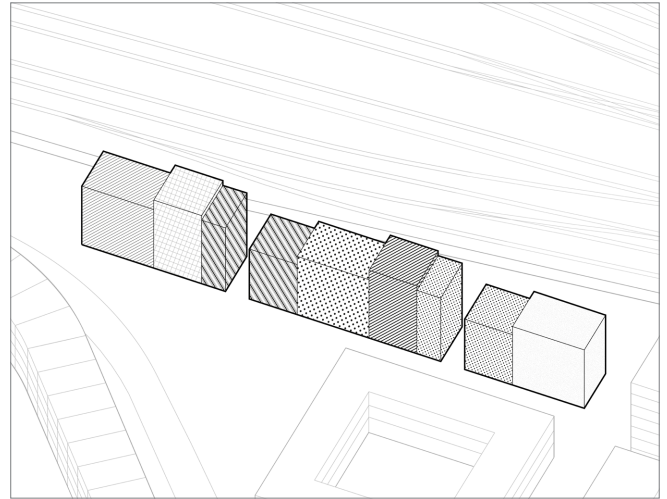


Partition in smaller volumes



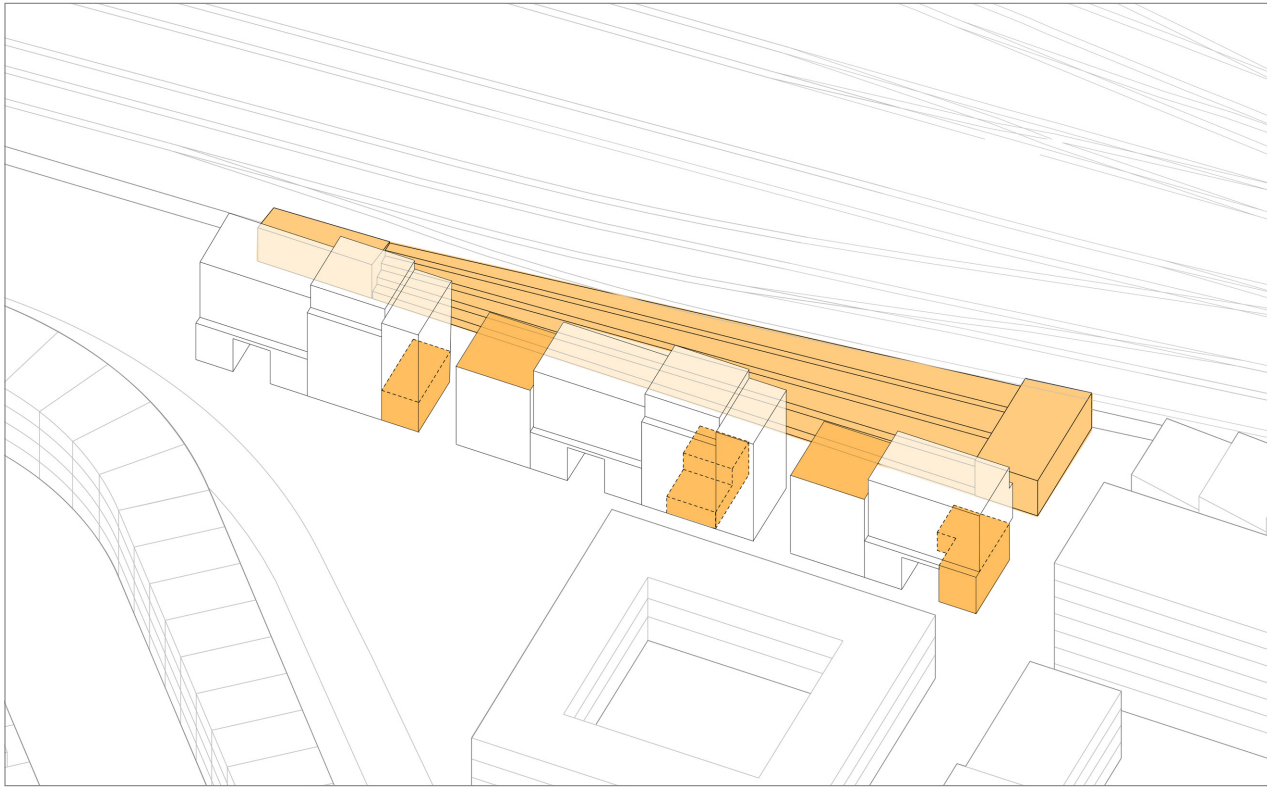


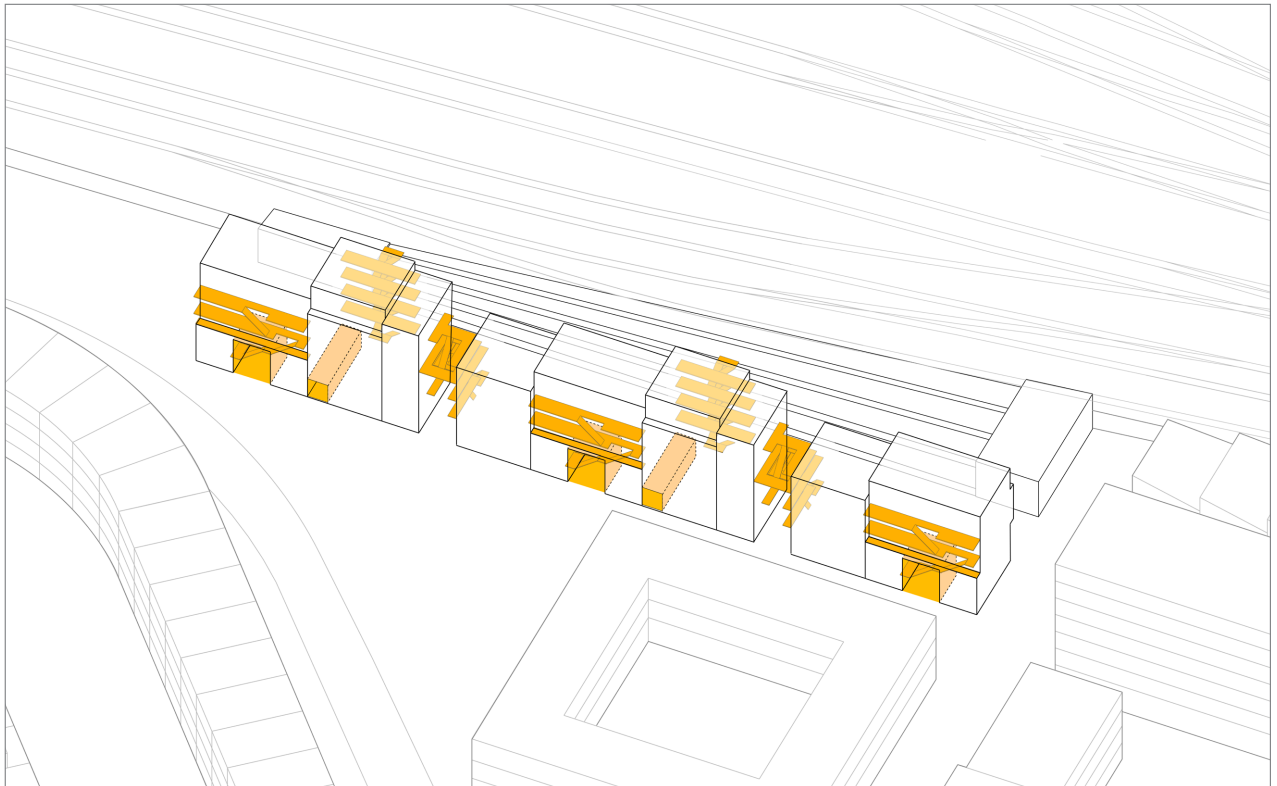
Variation in height & width



Individualize in typologies, tenures and appearance

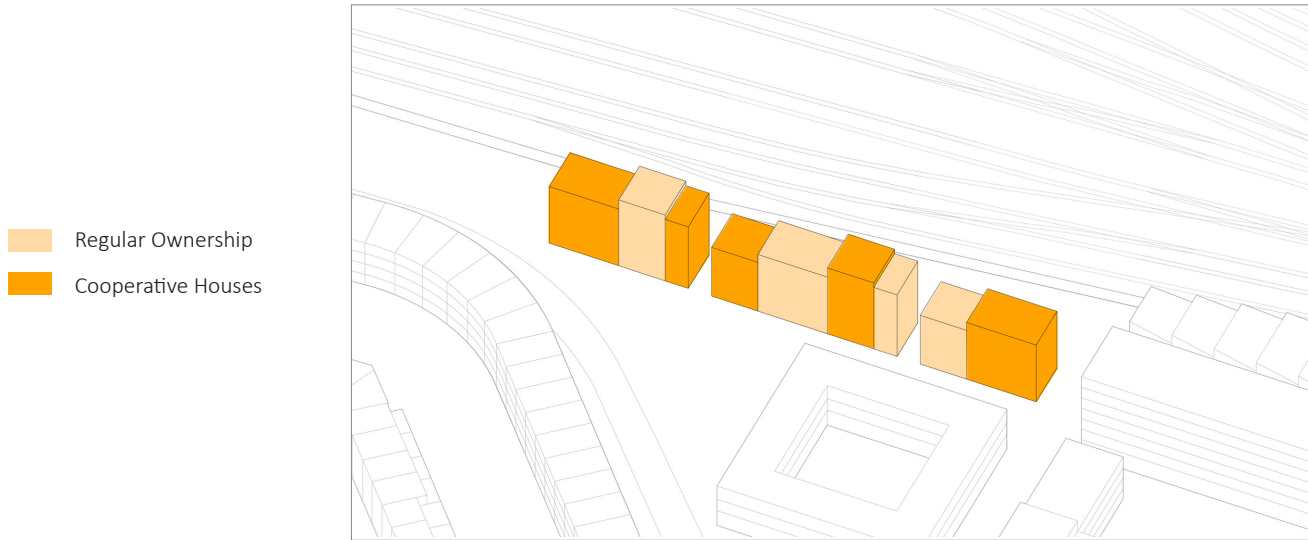
## Shared Spaces

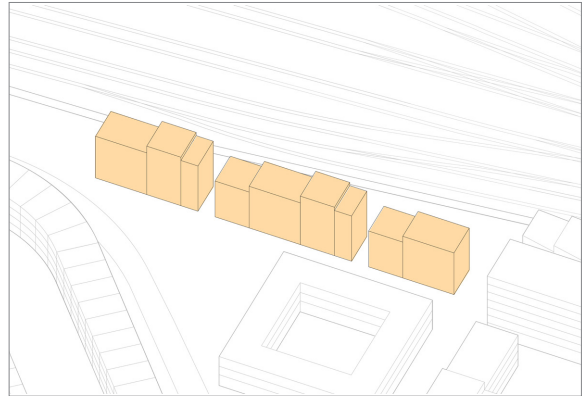
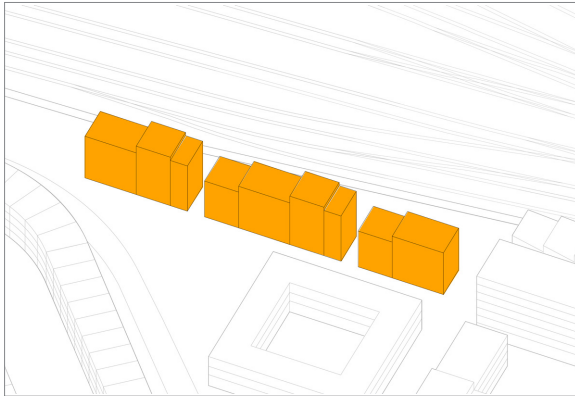
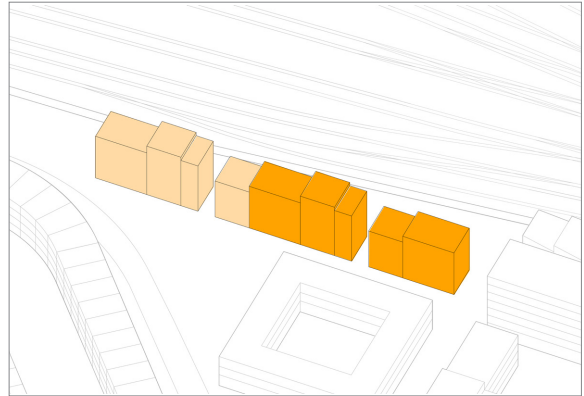
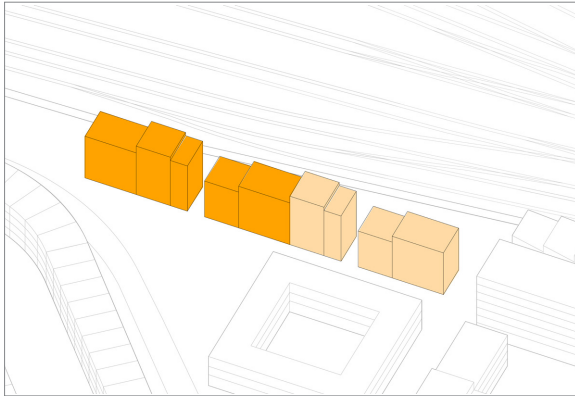




## Tenure Mix

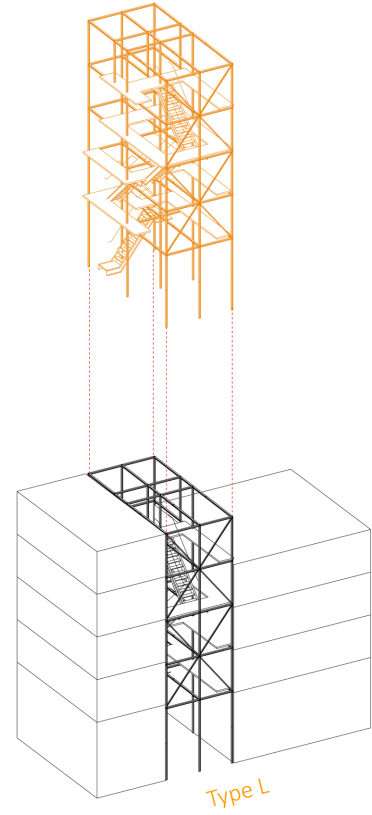
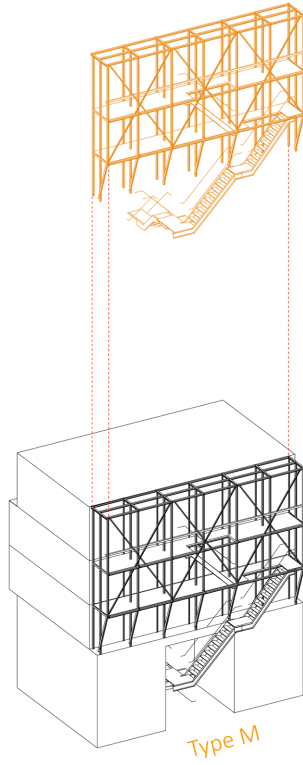
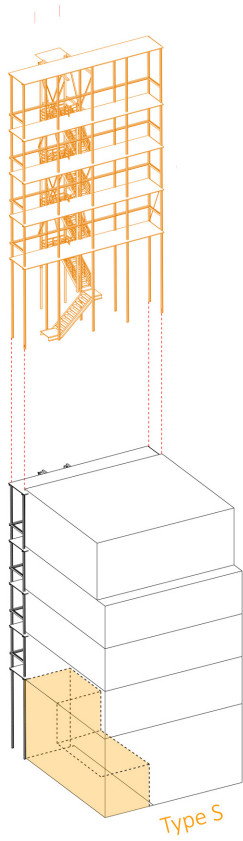
To allow a wide mix of different user groups with different social demands, income levels and expectations to the living environment, my project mixes two types of tenure: Regular apartments in ownership and cooperative houses for community living. As the concept of the buildings are flexible, with each typology repeating itself, the form of tenure of each building could be adapted until a late stage of the development. Even after completion, the simple construction allows for future adaptations





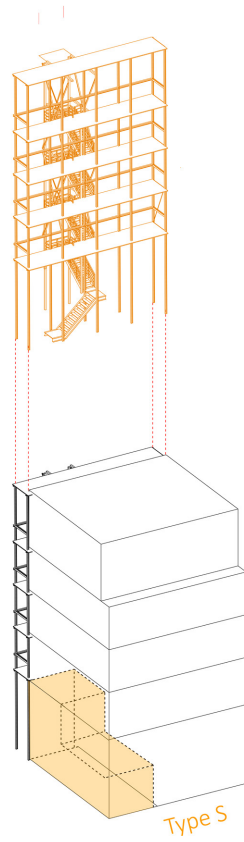
## Typologies & Circulation Spaces

One of the main aspects of the design are the three buildinging typologies and the exterior stairs. Each buildinging typology is dedicated to a particular user group. House S serves as a hybrid building providing living space for individual living situations for people, that are struggling to find suitable living space on the regular housing market. These group of people could be single parents or elderly living alone, for instance. House M is designed for different sized families with different needs, and House L is designed for solo dwellers or couples with small, functional apartments and a particular focus on collective spaces for casual encounters. By combining similiar user groups as one building community, common interests are likely to be established among residences. The stairs play an essential role of each building, serving, next to the access to the apartments, also as an outdoor extension of the private living space. This way casual encounters between residences are being promoted by turning the typically functional character of the stairs into a pleseant social zone to sit and stay.



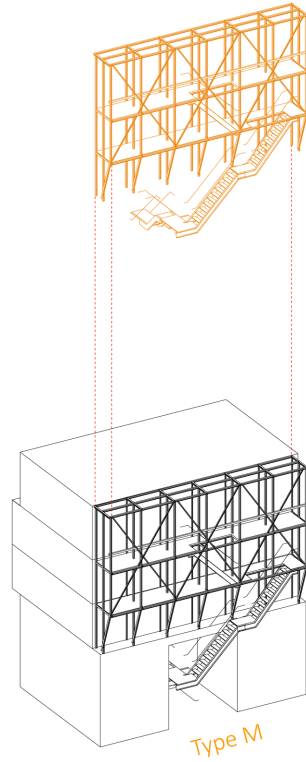


Type S





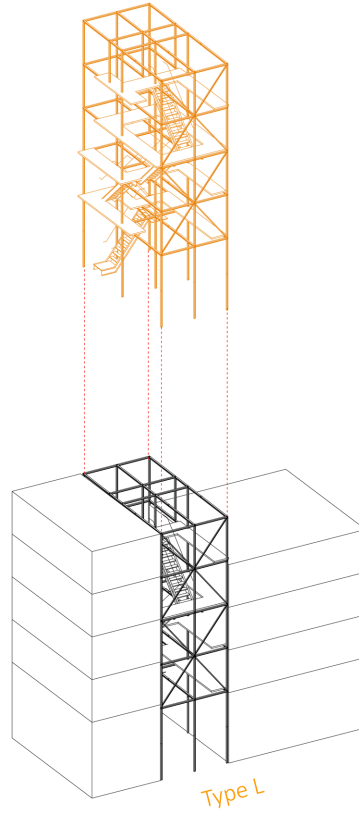
# Type M







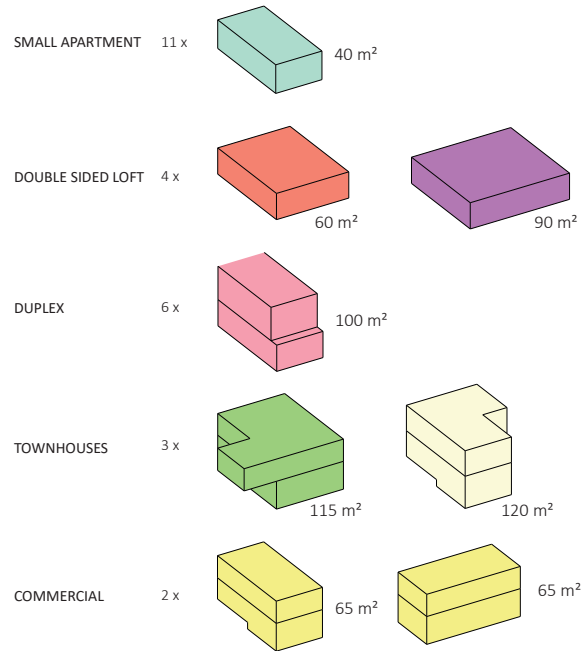
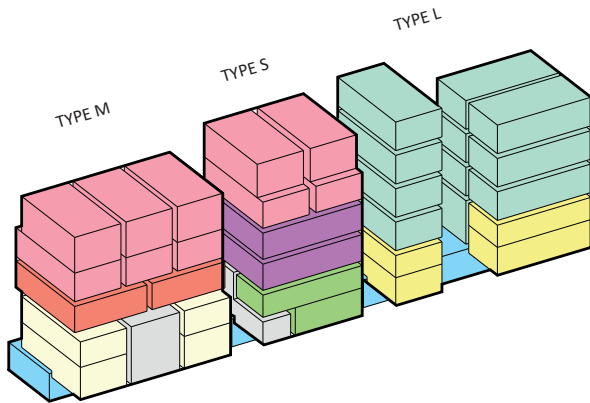
# Type L





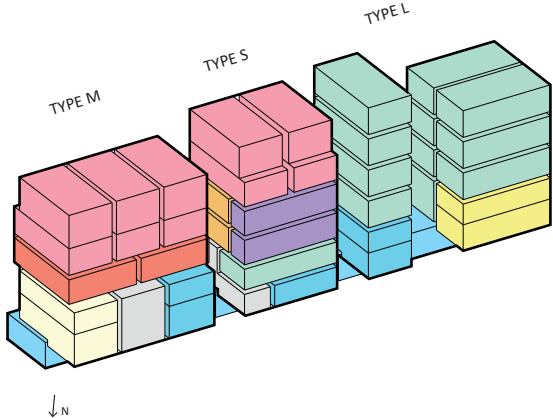




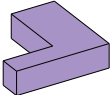
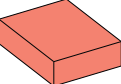
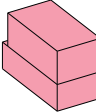
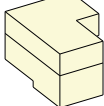
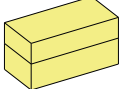
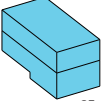
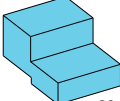
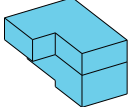
# Apartment Typology - Ownership Houses





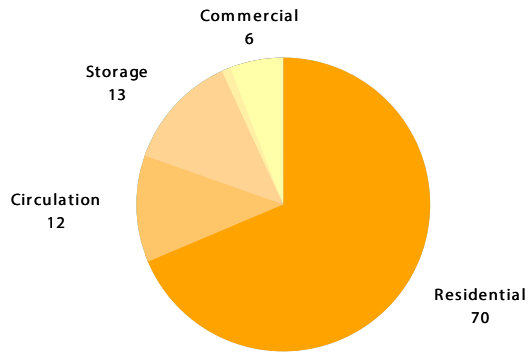
# Apartment Typology - Co-op Houses



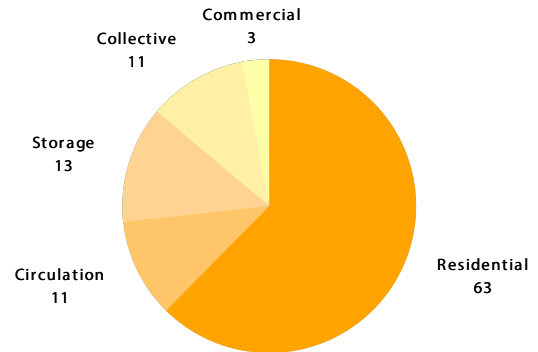
SMALL APARTMENT	14 x	 30 m <sup>2</sup>	 40 m <sup>2</sup>	
DOUBLE SIDED LOFT	4 x	 60 m <sup>2</sup>	 60 m <sup>2</sup>	
DUPLEX	5 x	 100 m <sup>2</sup>		
TOWNHOUSE	1 x	 120 m <sup>2</sup>		
COMMERCIAL	1 x	 65 m <sup>2</sup>		
COLLECTIVE SPACE	3 x	 65 m <sup>2</sup>	 80 m <sup>2</sup>	 90 m <sup>2</sup>

# Percentage of Gross Floor Area

## Ownership

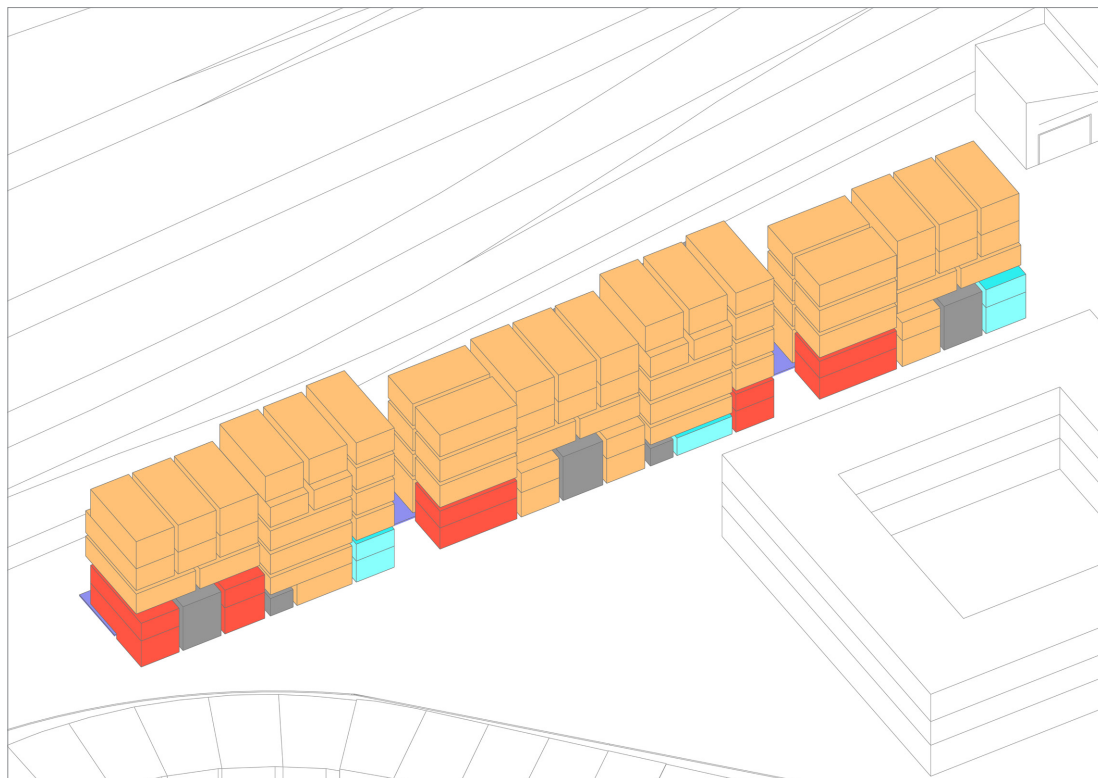


## Co-op



# Functions

- Residential
- Collective Spaces
- Commercial
- Entrance



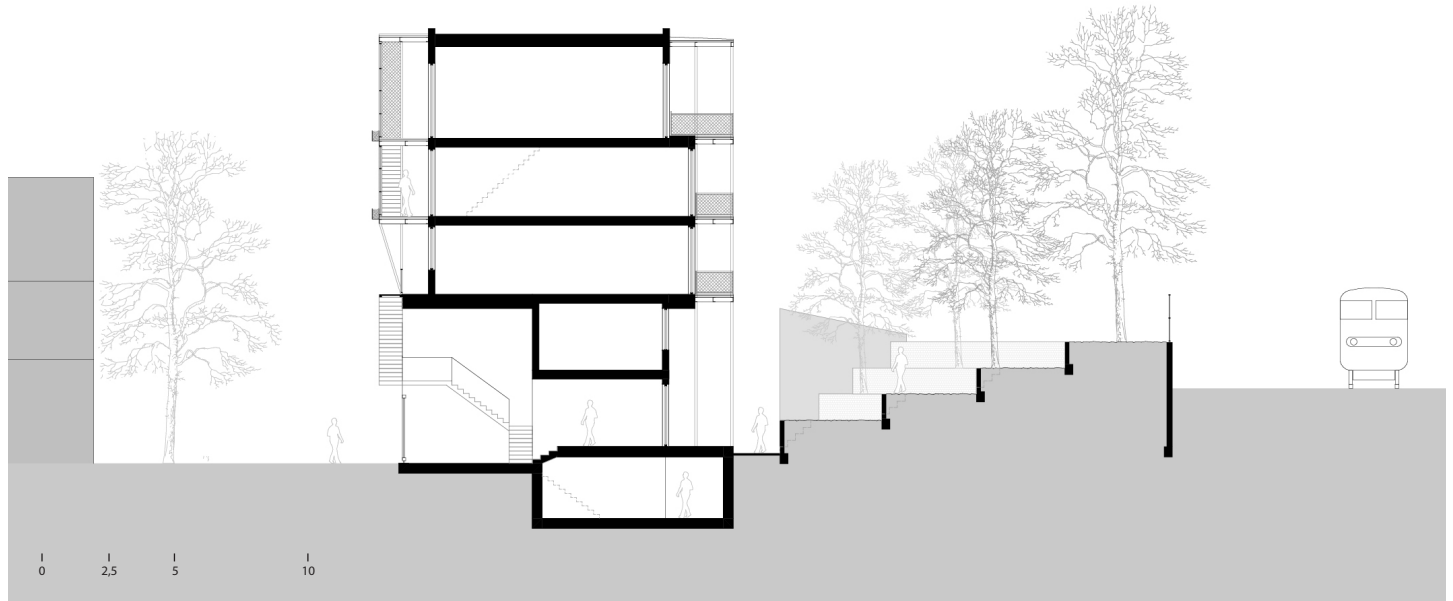
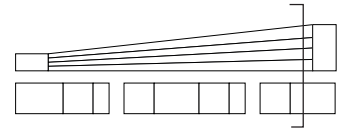




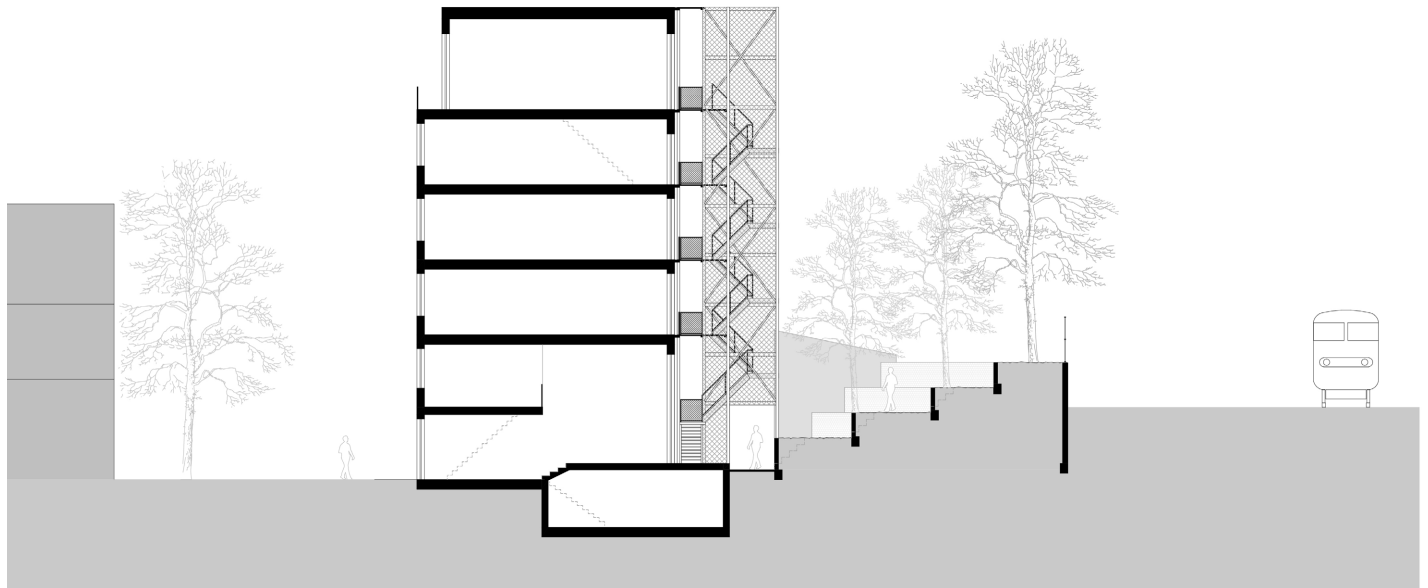
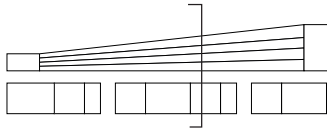
An aerial photograph of a city grid, overlaid with a semi-transparent orange filter. The image shows a dense network of streets and buildings, with a prominent circular plaza or roundabout in the lower-left quadrant. The text '04 Floorplans, Sections & Elevations' is centered in the upper half of the image in a white, sans-serif font.

# 04 Floorplans, Sections & Elevations

# Section House M

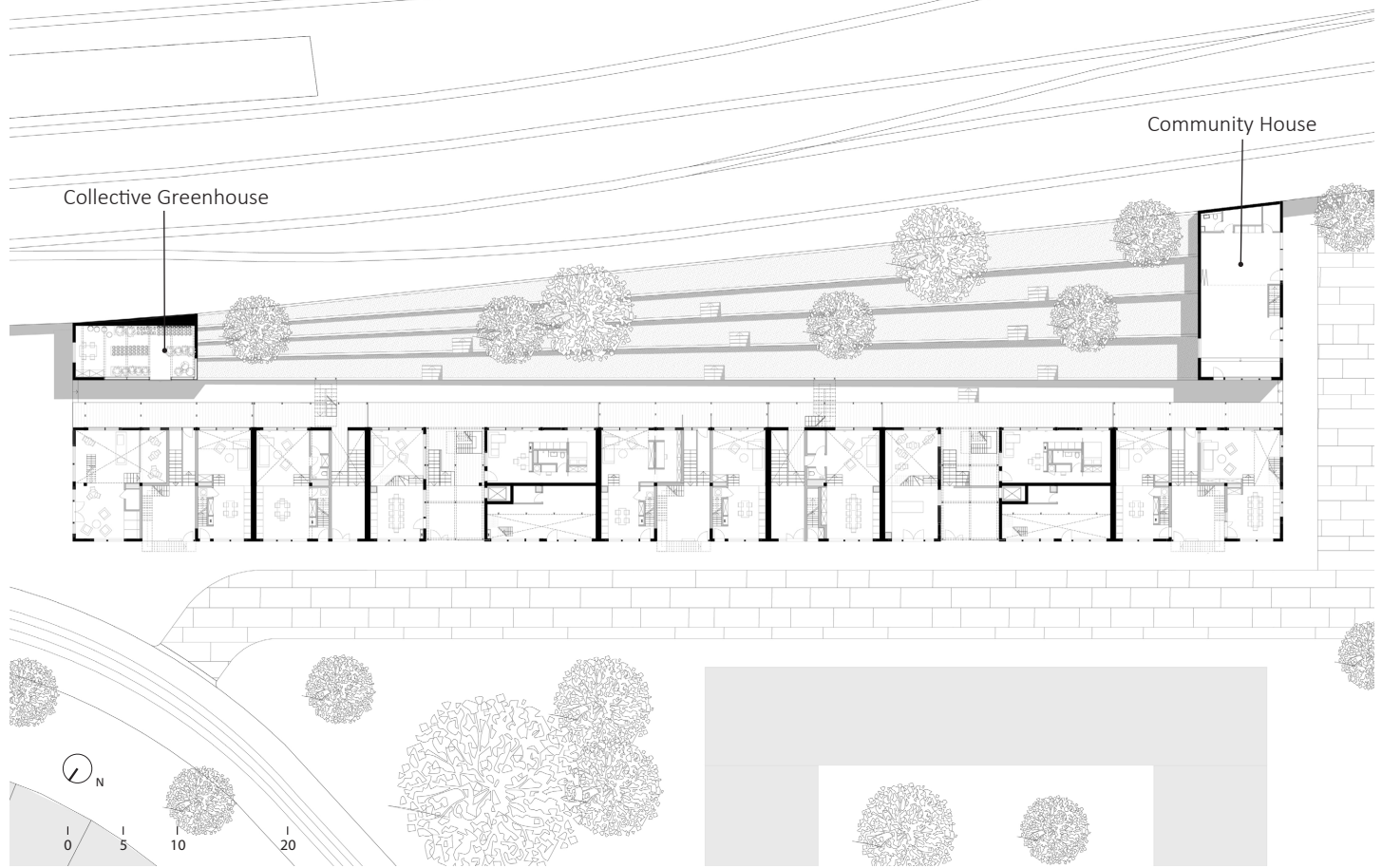


Section House S

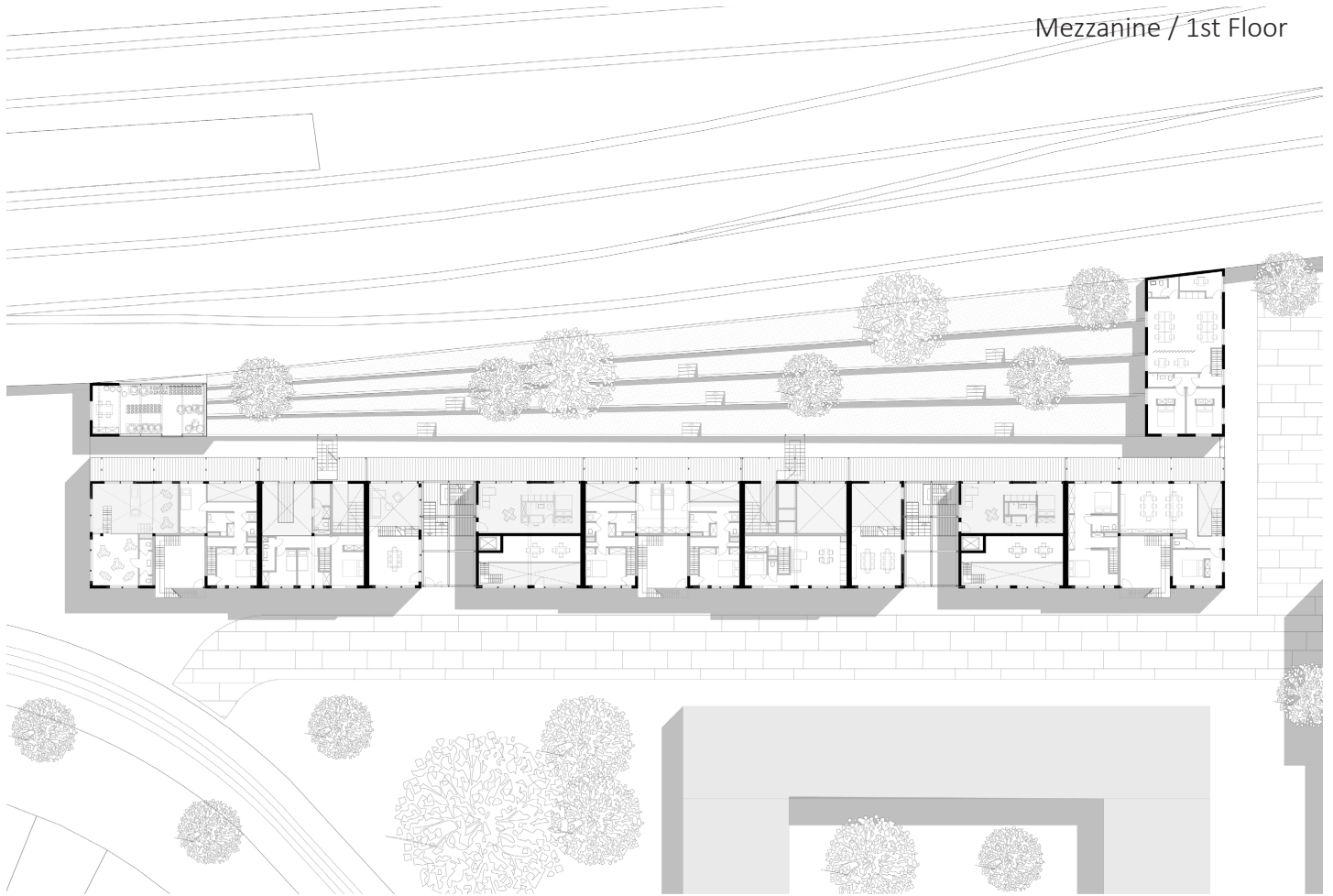




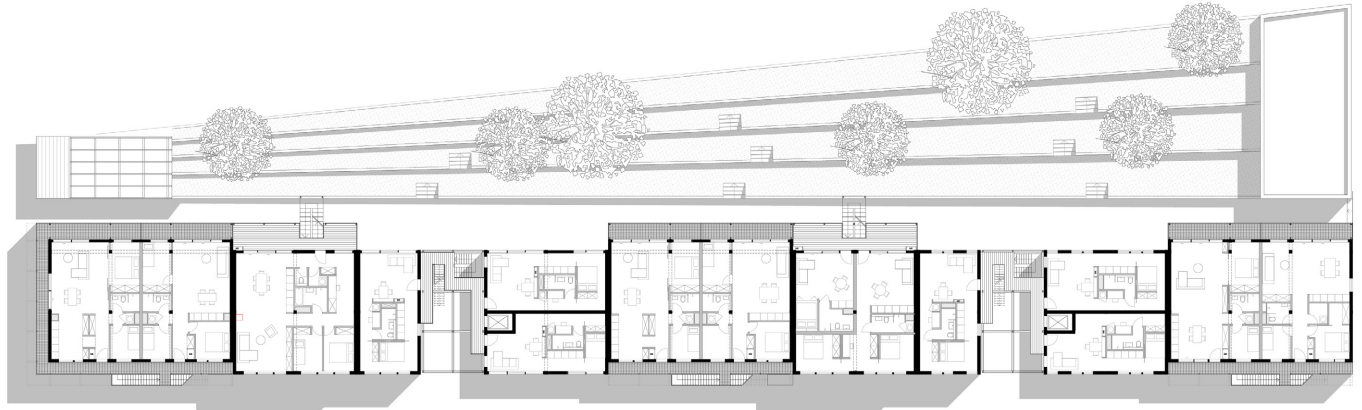
Groundfloor



Mezzanine / 1st Floor

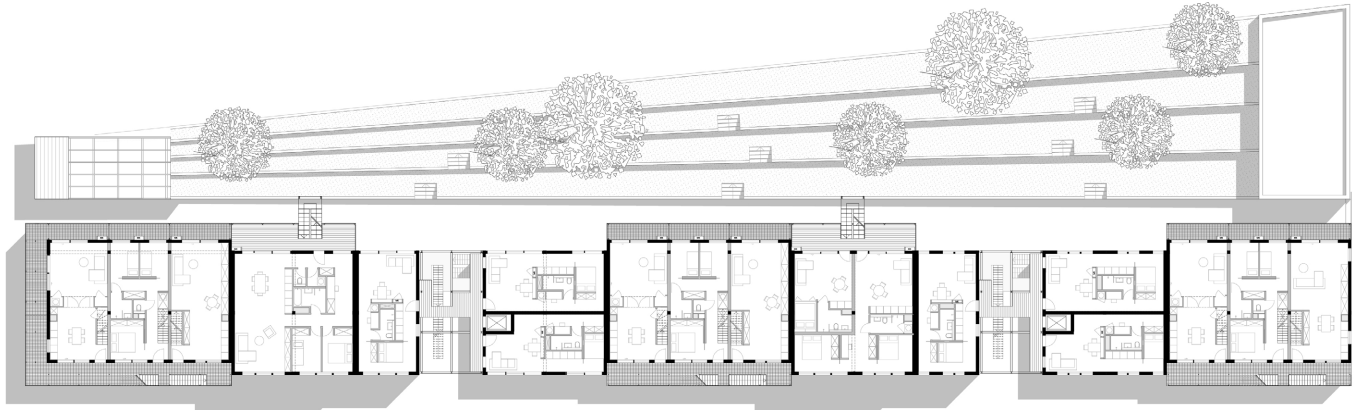


# 2nd Floor

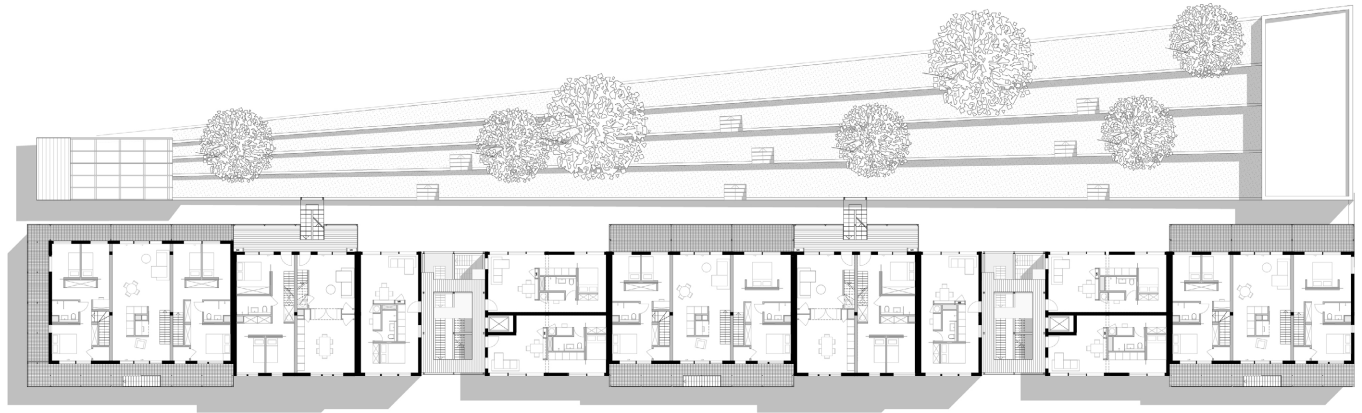


0 5 10 20

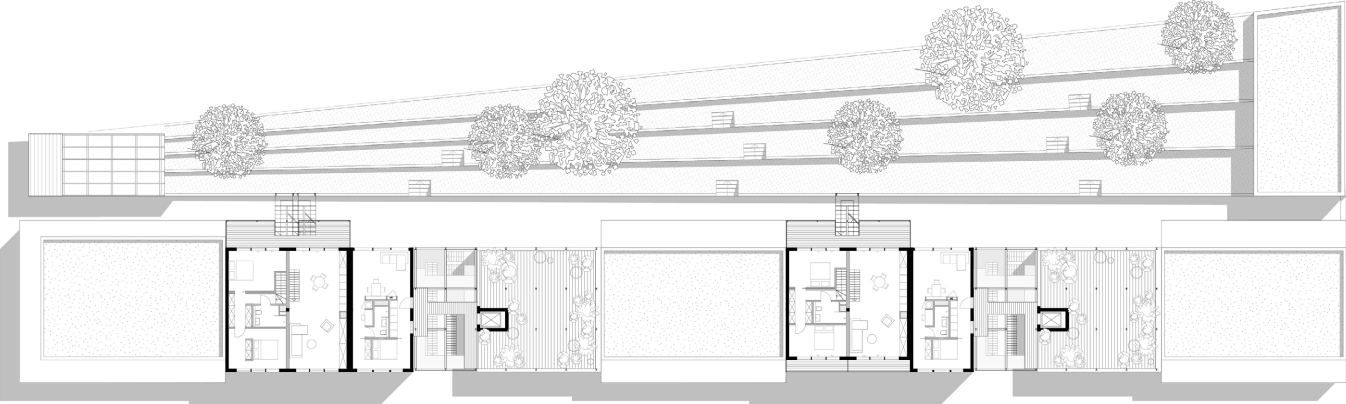
3rd Floor



# 4th Floor

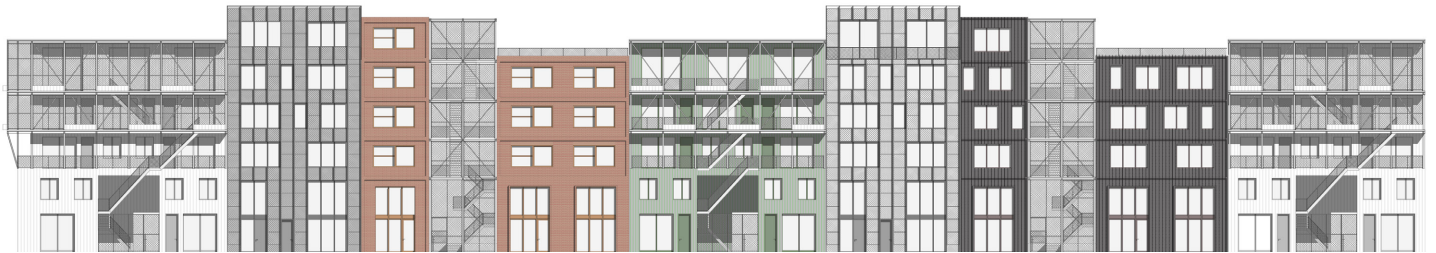


0 5 10 20



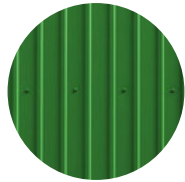
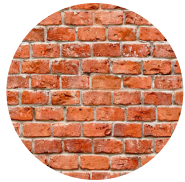
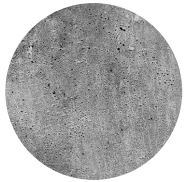


# Street Elevation



0 5 10 20

## Facade Material Palette





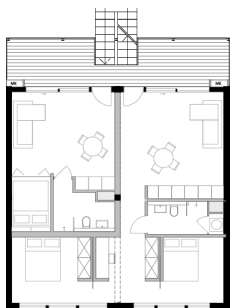
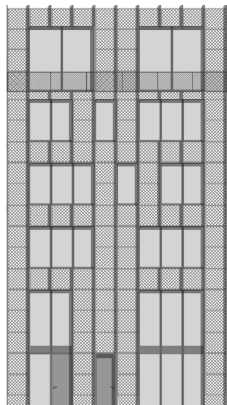


The background of the slide is an aerial photograph of a city, showing a dense grid of streets and buildings. The entire image is covered with a semi-transparent orange filter. In the upper right quadrant, the text '05 Unit Types' is displayed in a white, sans-serif font. The number '05' is significantly larger than the words 'Unit Types'.

# 05 Unit Types

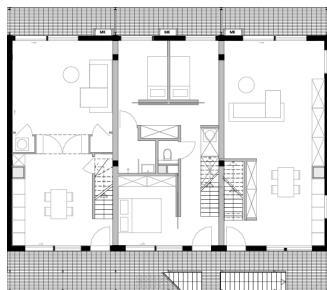
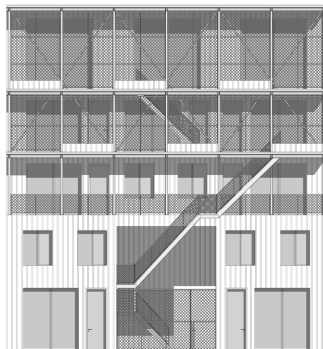
## HOUSE S

Hybrid



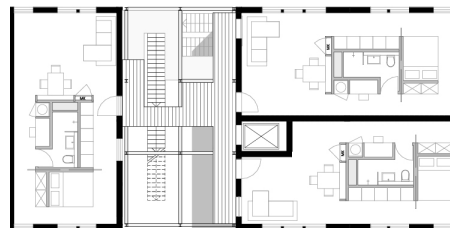
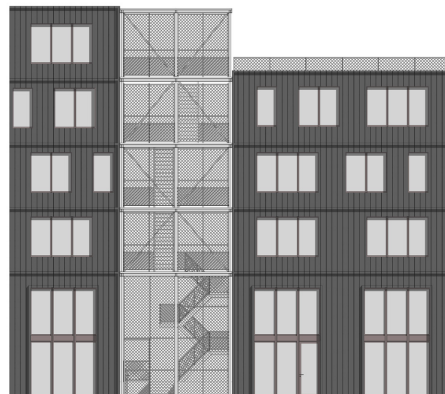
## HOUSE M

Family Type

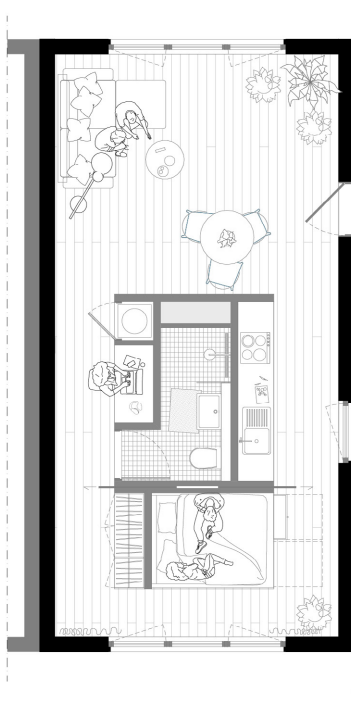
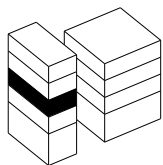


## HOUSE L

Solo Living

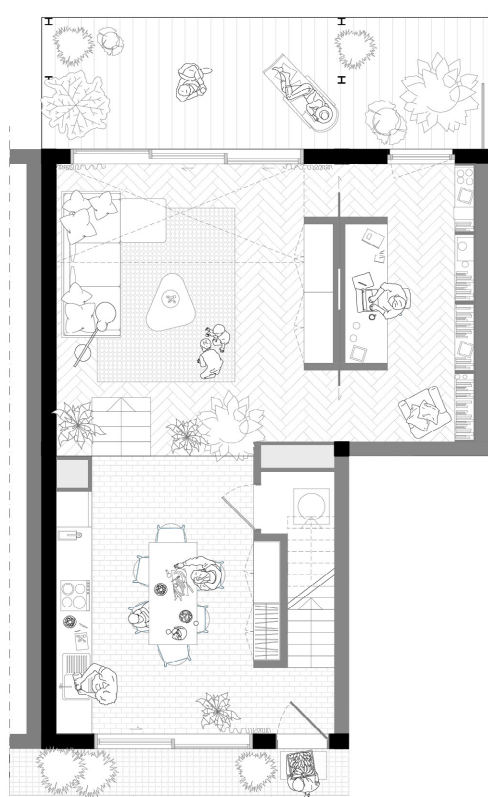
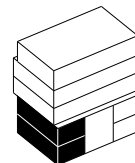


House L - Solo/Couple apartment

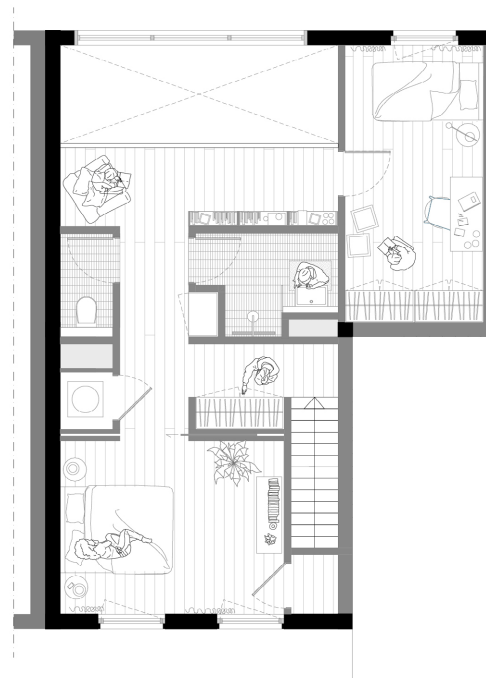




# House M - Townhouse apartment



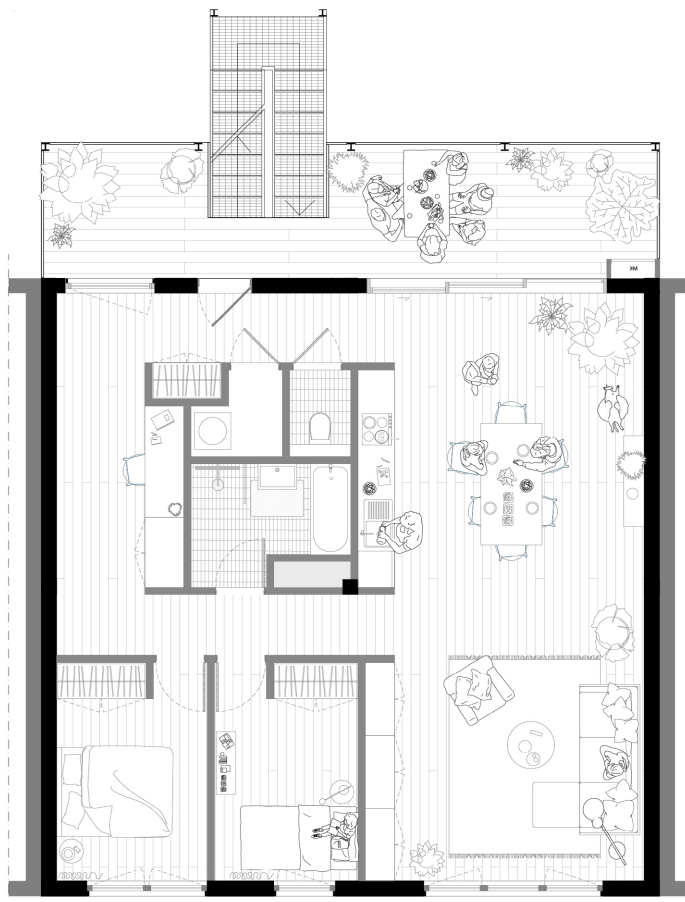
Groundfloor



1st floor



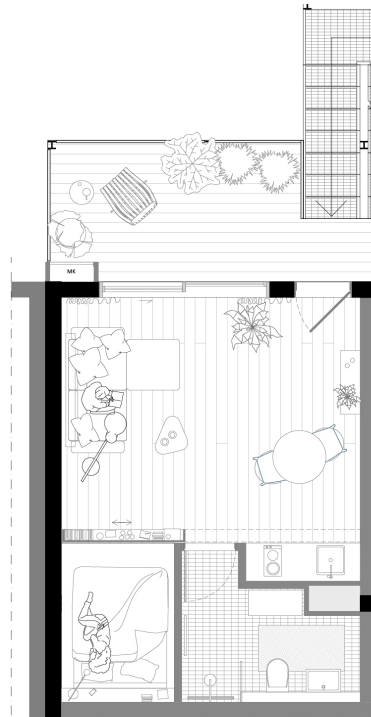
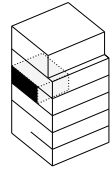
# House S - Loft apartment







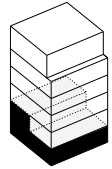
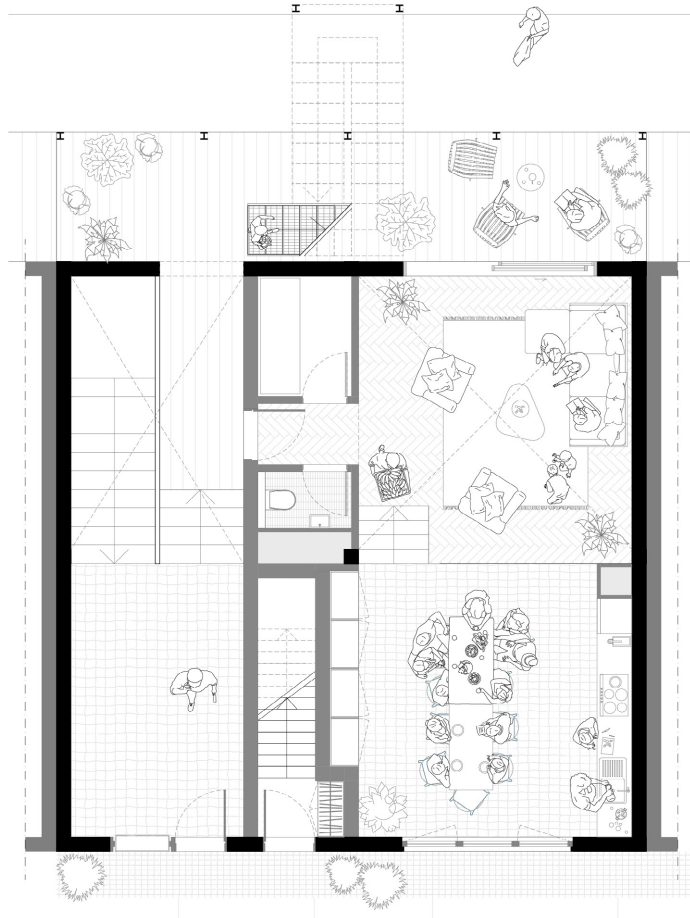
# House S - Micro apartment







House S - Collective Livingroom







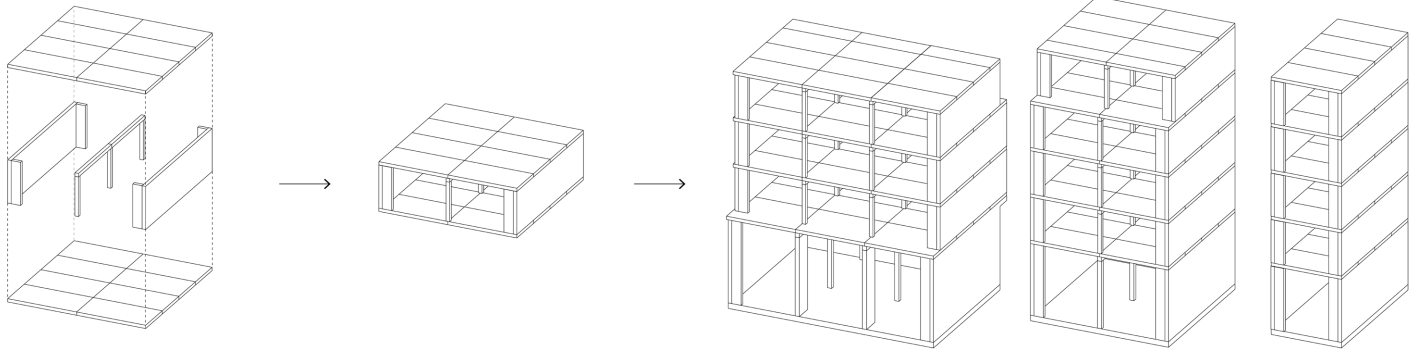


An aerial photograph of a city grid, overlaid with a semi-transparent orange filter. The image shows a dense network of streets and buildings, with a prominent circular intersection in the lower-left quadrant. The text '06 Building Technology' is centered in the upper half of the image.

# 06 Building Technology

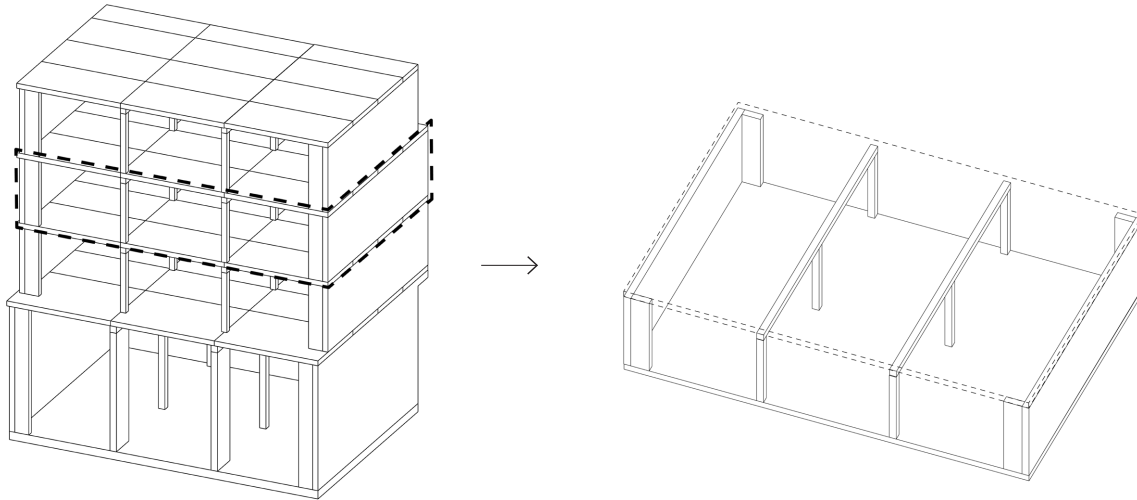


## Loadbearing Structure - CLT Timber construction



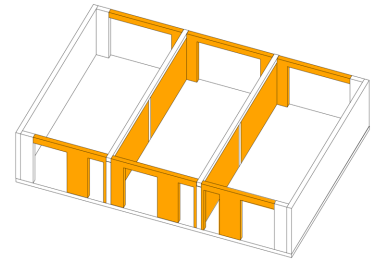
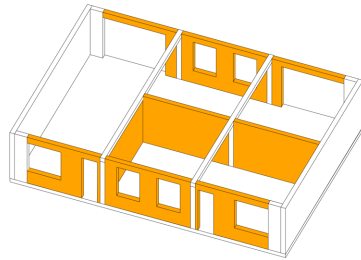
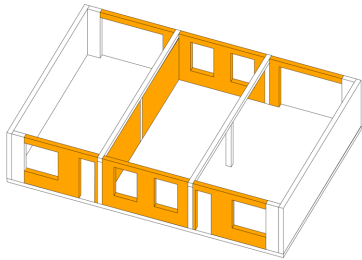
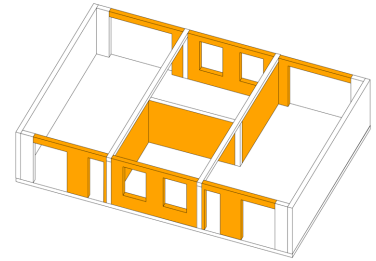
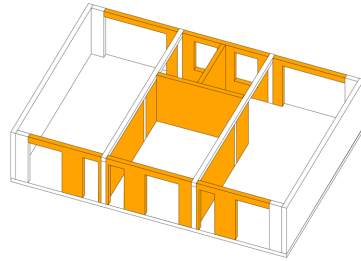
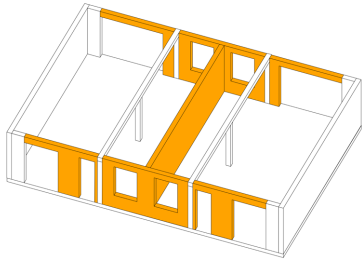


Flexible infill for future adaptations

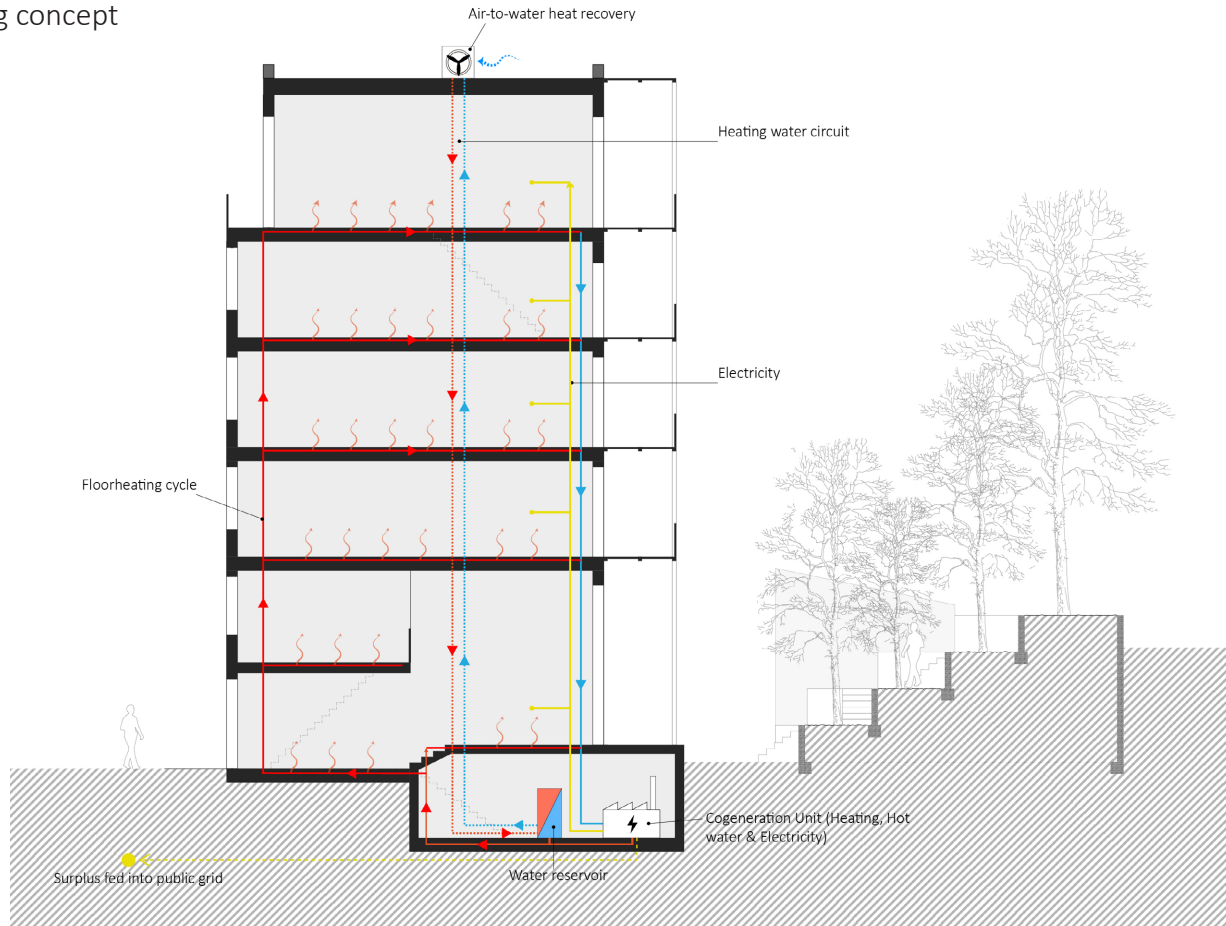


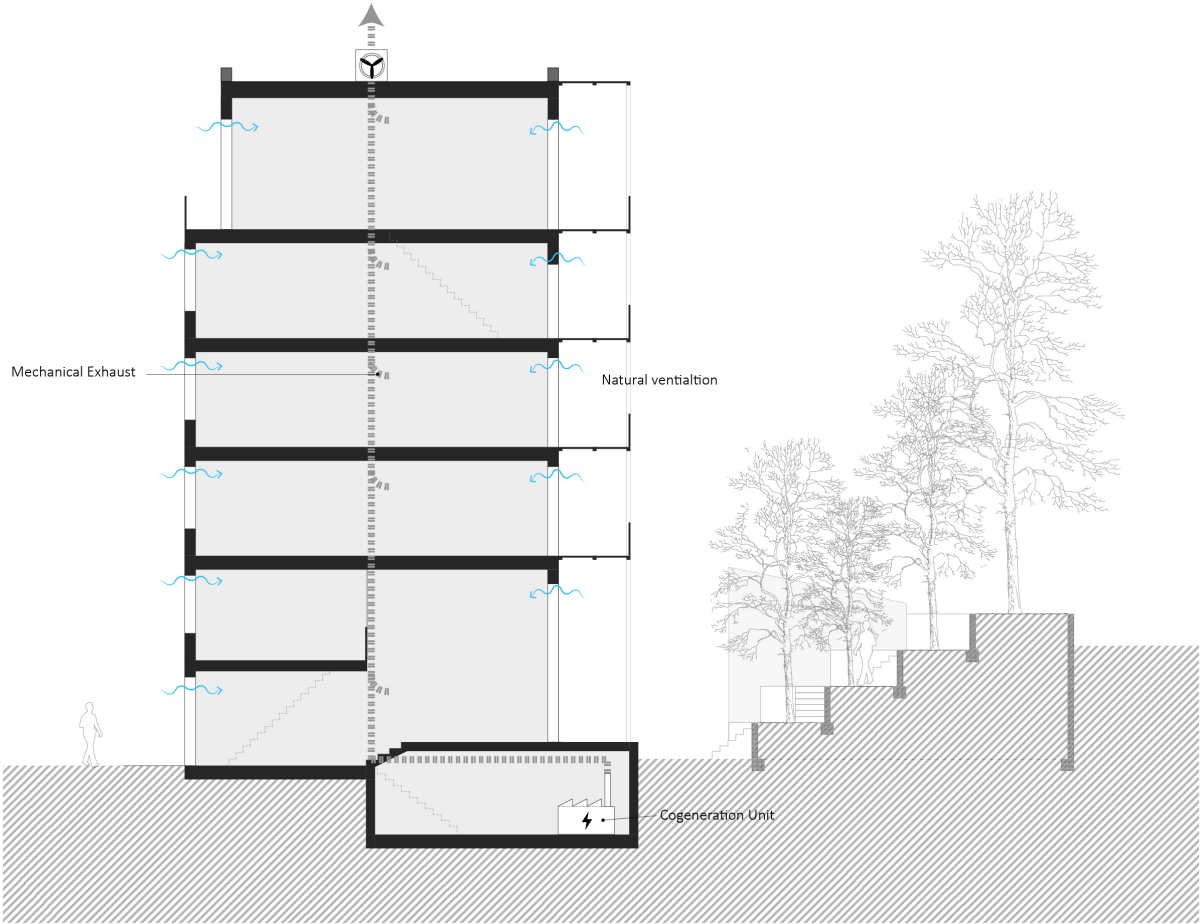
## Flexible infill for future adaptations

The loadbearing structure is designed in an open manner through a column-beam construction to allow flexible infills. Walls can be re-drawn in the future in various ways without interfering with the main construction. This way the apartments and the facades can be easily adapted and transformed to future needs.



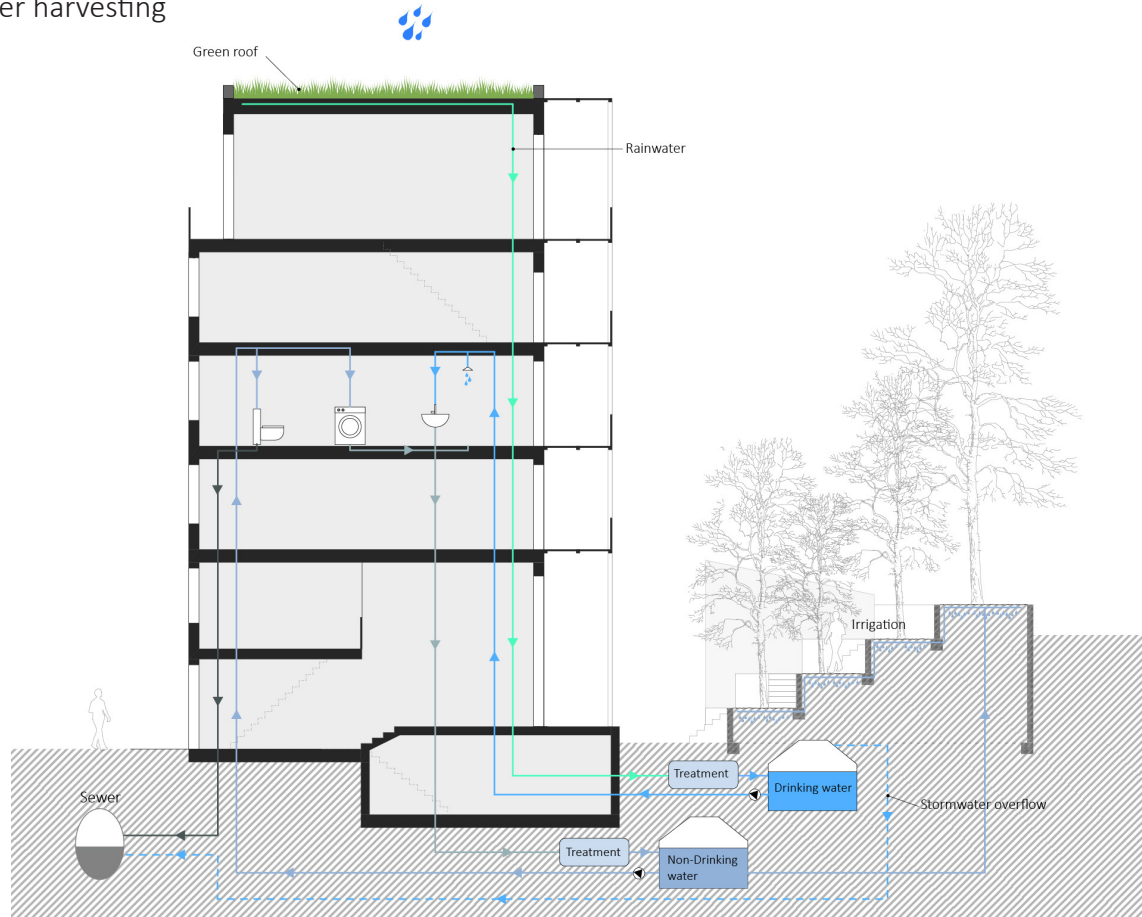
# Heating concept



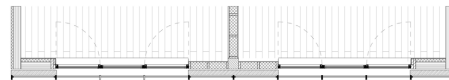
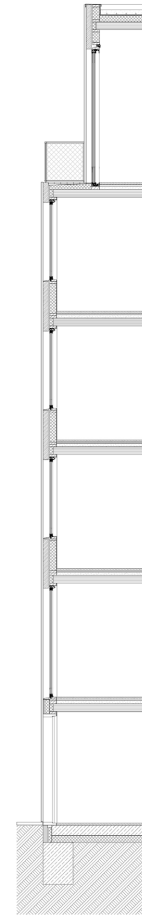
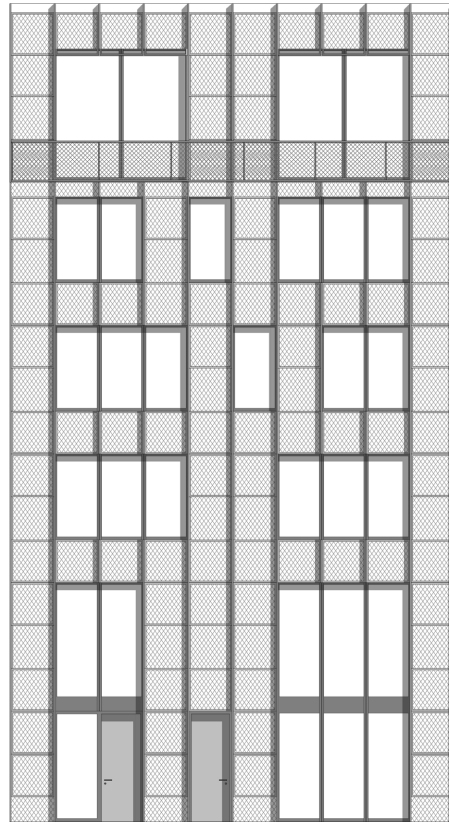




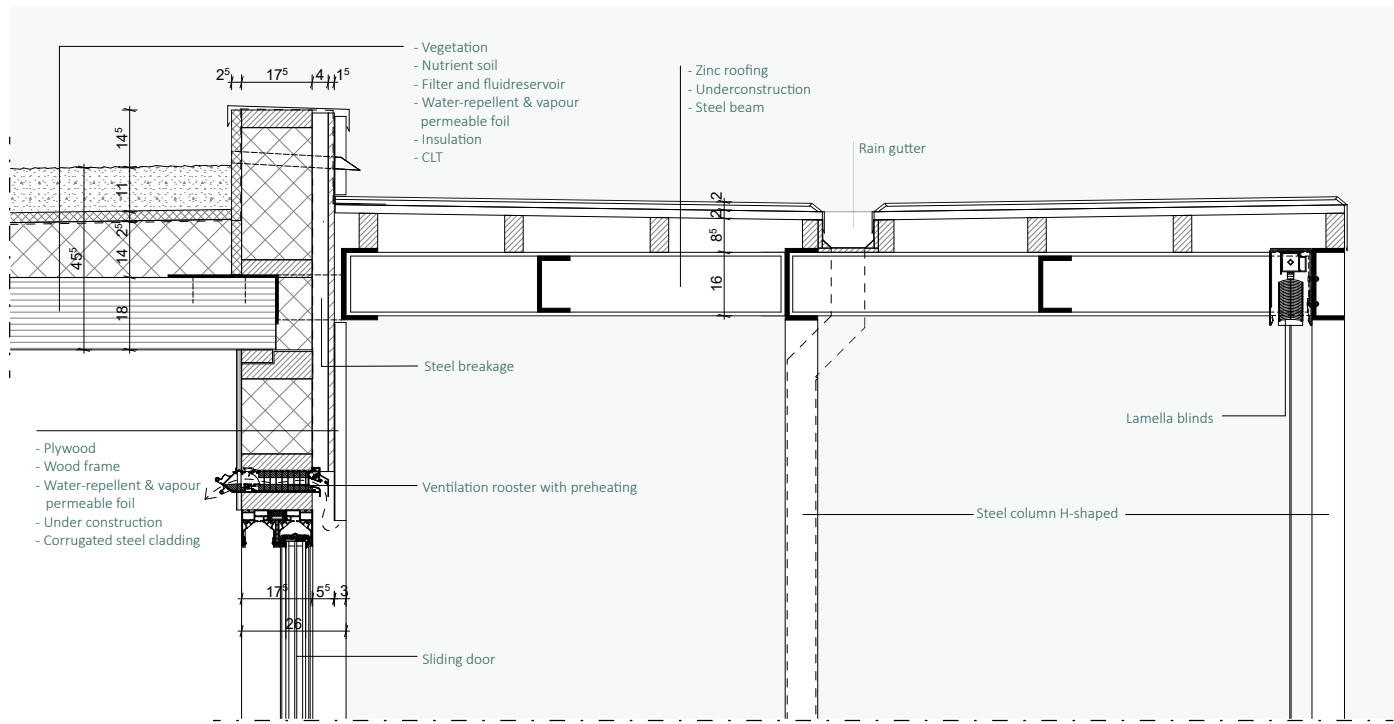
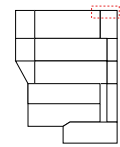
# Rainwater harvesting

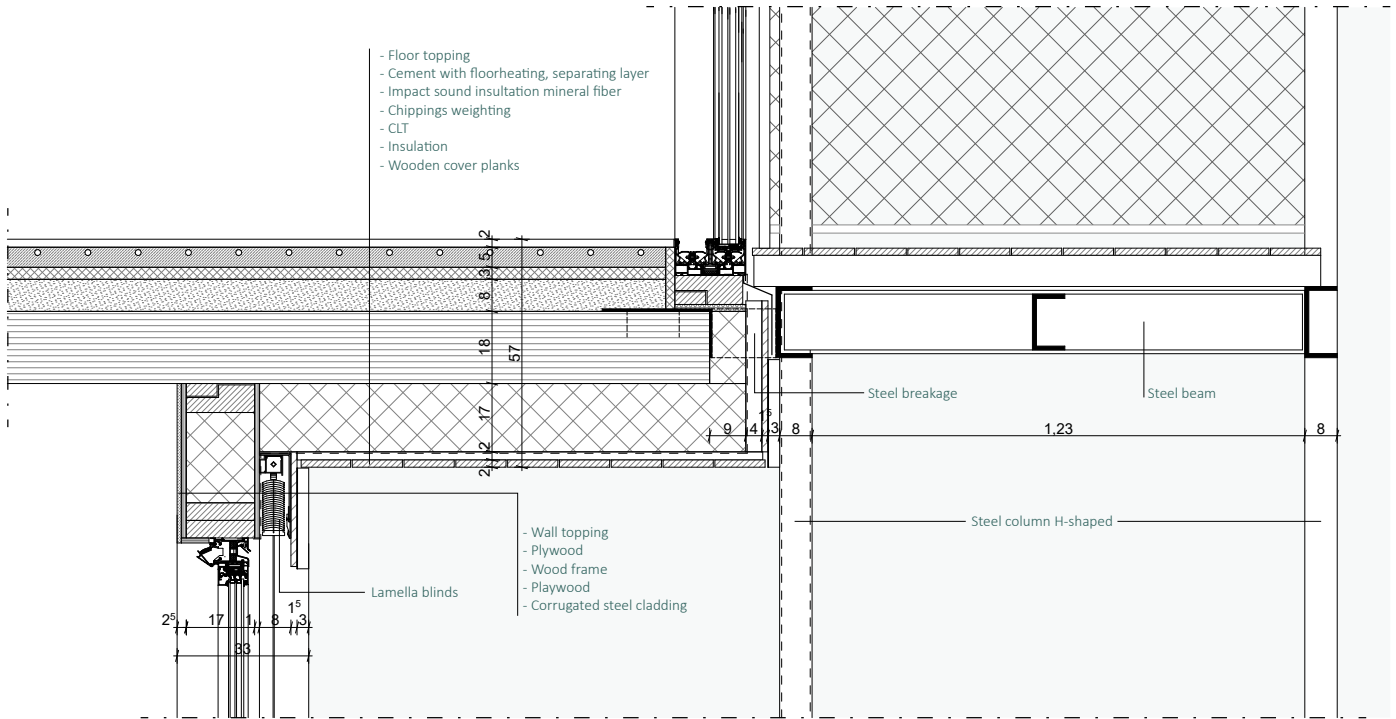
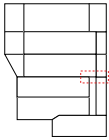


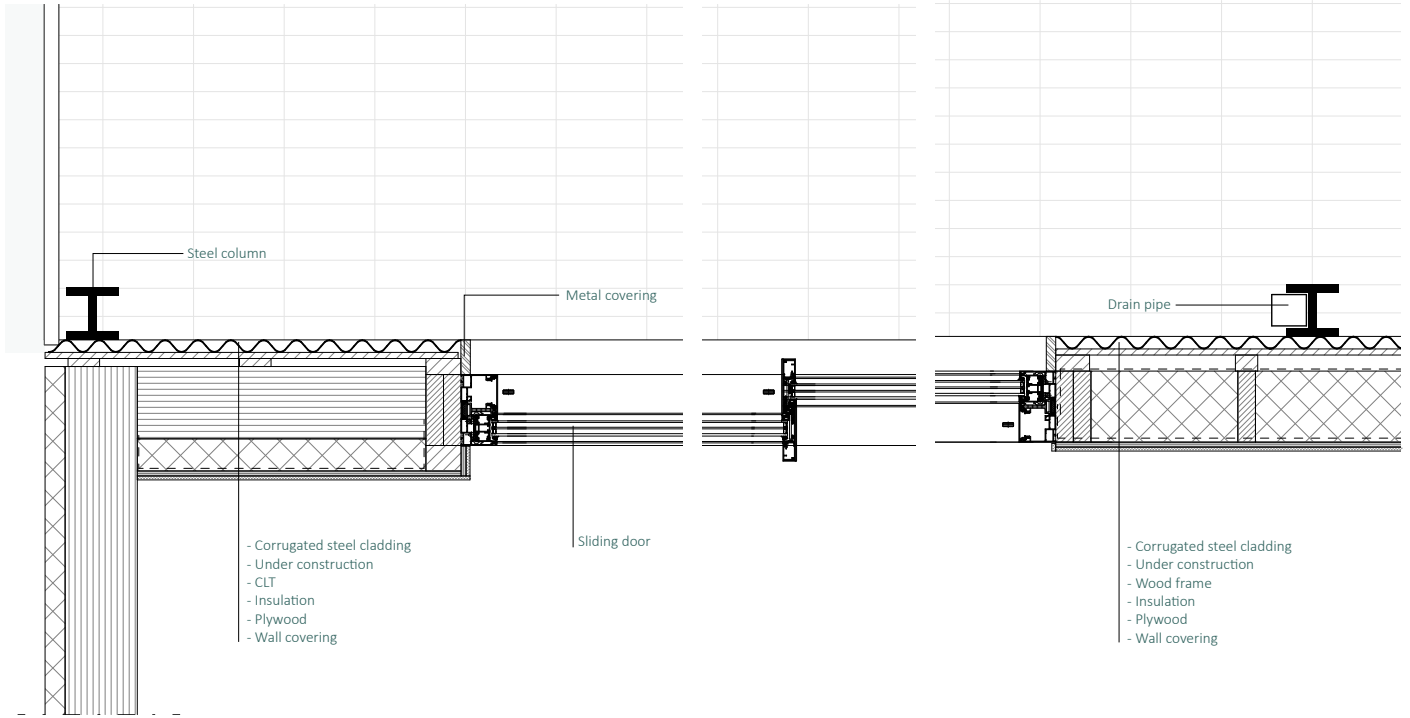
# Facade Fragment



0 1,25 2,5 5

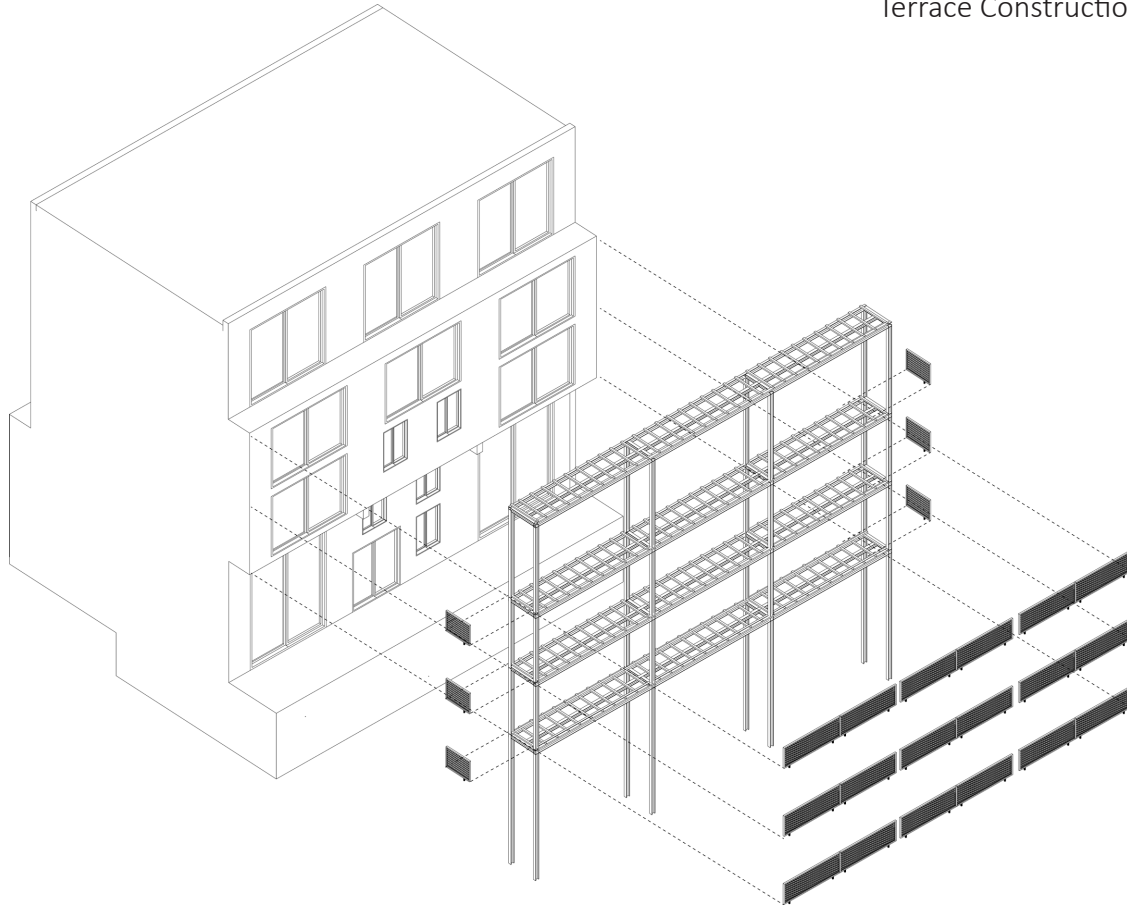








## Terrace Construction Principle







An aerial photograph of a city grid, overlaid with a semi-transparent orange filter. The image shows a dense network of streets and buildings, with a prominent circular intersection in the lower-left quadrant. The text '07 Exterior Impressions' is centered in the upper half of the image.

# 07 Exterior Impressions



West garden entrance

Community House for gatherings,  
co-working & guest rooms





Residence walkway

Collective garden with seating areas







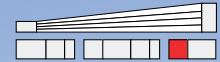


Collective Greenhouse &  
East garden entrance





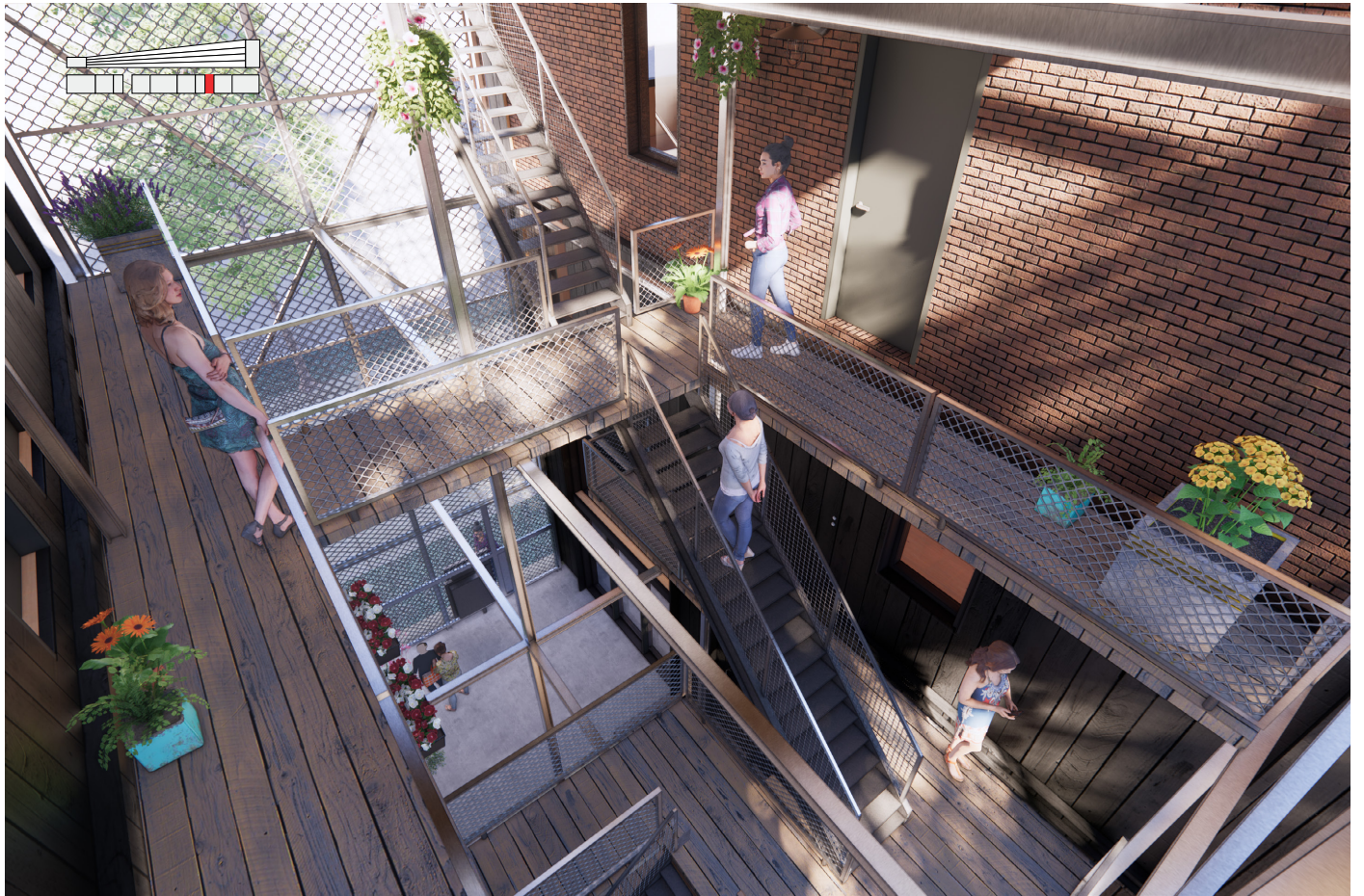




Collective Rooftop with indoor kitchen











**Maximilian Mehl** | 5379210

June 2022  
Faculty of Architecture & the Built Environment  
TU Delft  
Advanced Housing Design (AR3AD100)

Supervised by:  
Dr. Anne Kockelkorn  
Ir. Olv Klijn  
Ir. Ferry Adema