

# Sustainable Water Management scheme for the Negin Safari Park

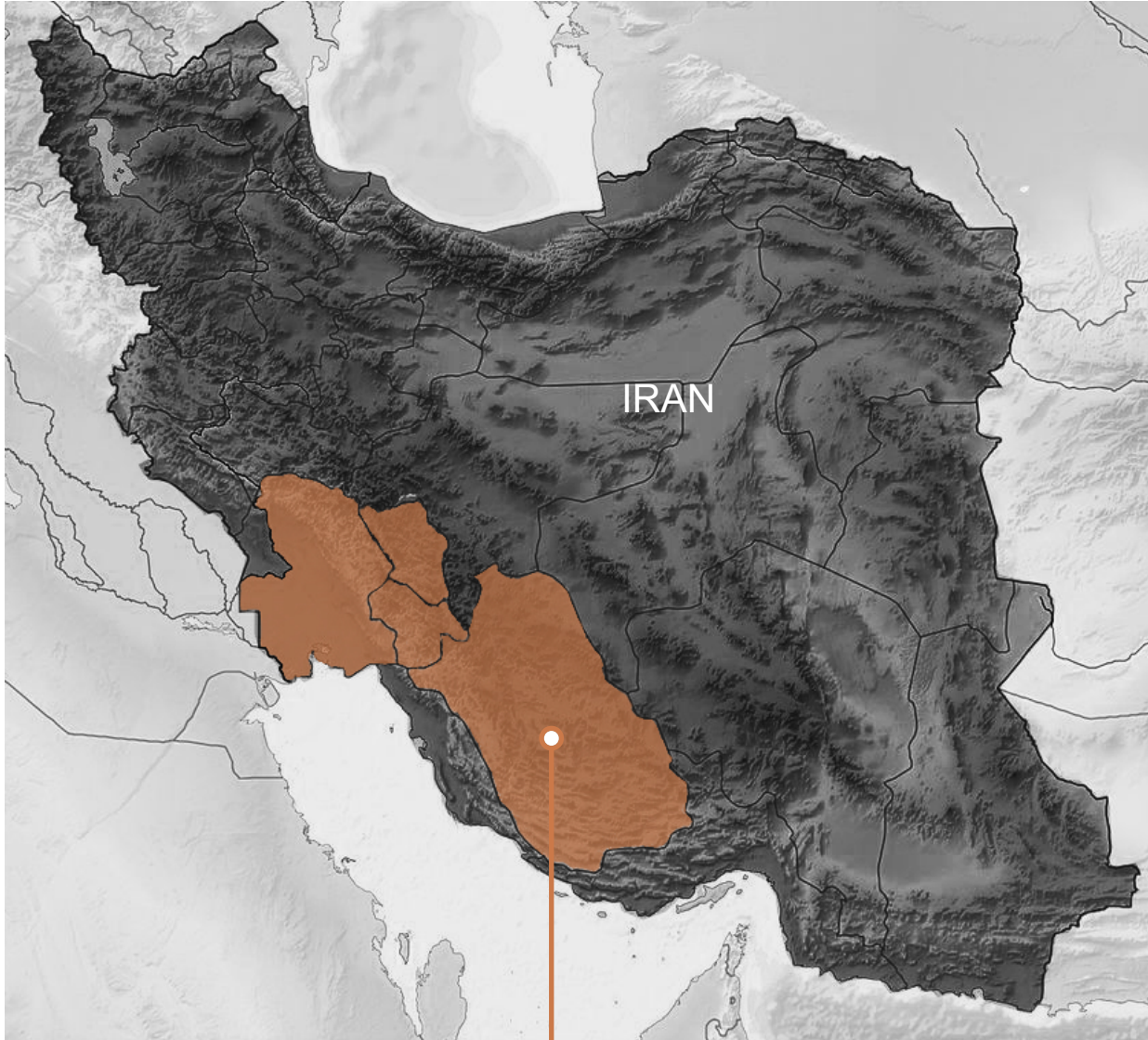

# CONTEXT



40,000 Qashqai nomads exist

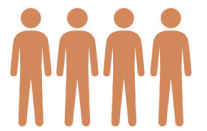

# CONTEXT



Live in tents



# CONTEXT



Drink water from wells



# CONTEXT



Occupation - Animal husbandry

# CONTEXT



Occupation - Carpet weaving

# CONTEXT



Occupation - Agriculture



# CONTEXT



Drought





# CONTEXT

Difficulty in finding grazing land for flocks

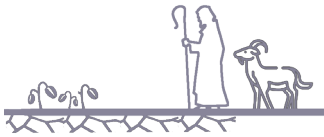

forcing community into Sedentism

Difficulty in finding grazing land for flocks

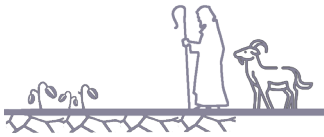

No platform to sell handicraft

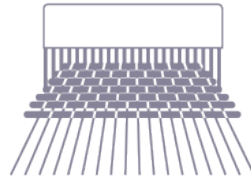

forcing community into Sedentism



Decline in sale

# CONTEXT

Difficulty in finding grazing land for flocks



No platform to sell handicraft

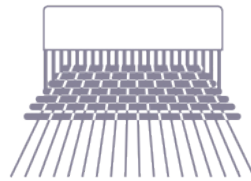

Youth migrating to city



forcing community into Sedentism



Decline in sale



Lack of people to take care of flock

Economic upliftment

Tourist influx



Local Qashqai community



Safari park

  
**TU Delft**  
Technolog, Policy  
and Management



# CONTEXT

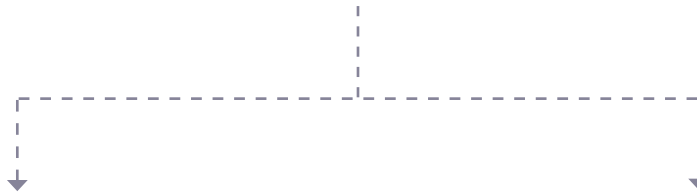
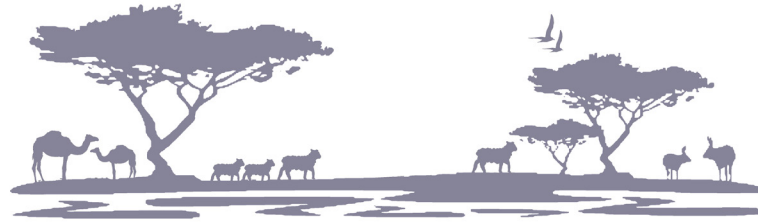

Participation in  
daily activities of  
the Qashqai



Revival of lost  
ecosystem

# PROBLEM STATEMENT

World resource institute : water resource graph in 20 years

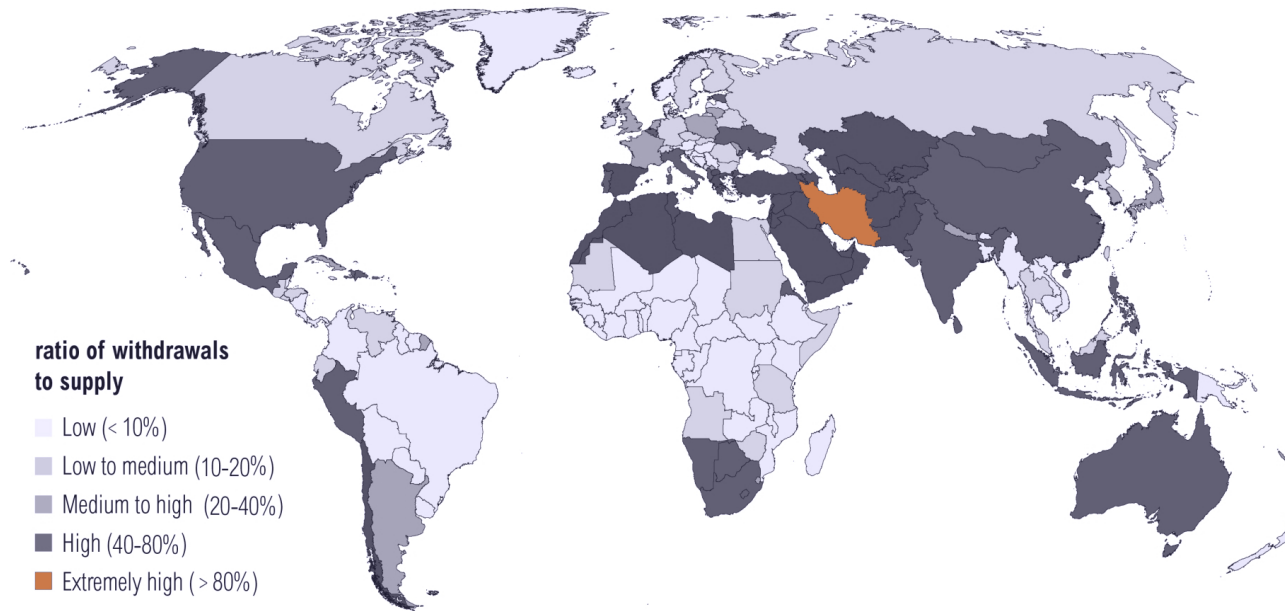

## PROBLEM STATEMENT - Drought



Environmental degradation



Ground water level depression



Water allocation controversies



Migration of birds and animals



Depletion of drinking water

# PROBLEM STATEMENT

## Tourist influx statistics versus annual rainfall for March 2017 - March 2018

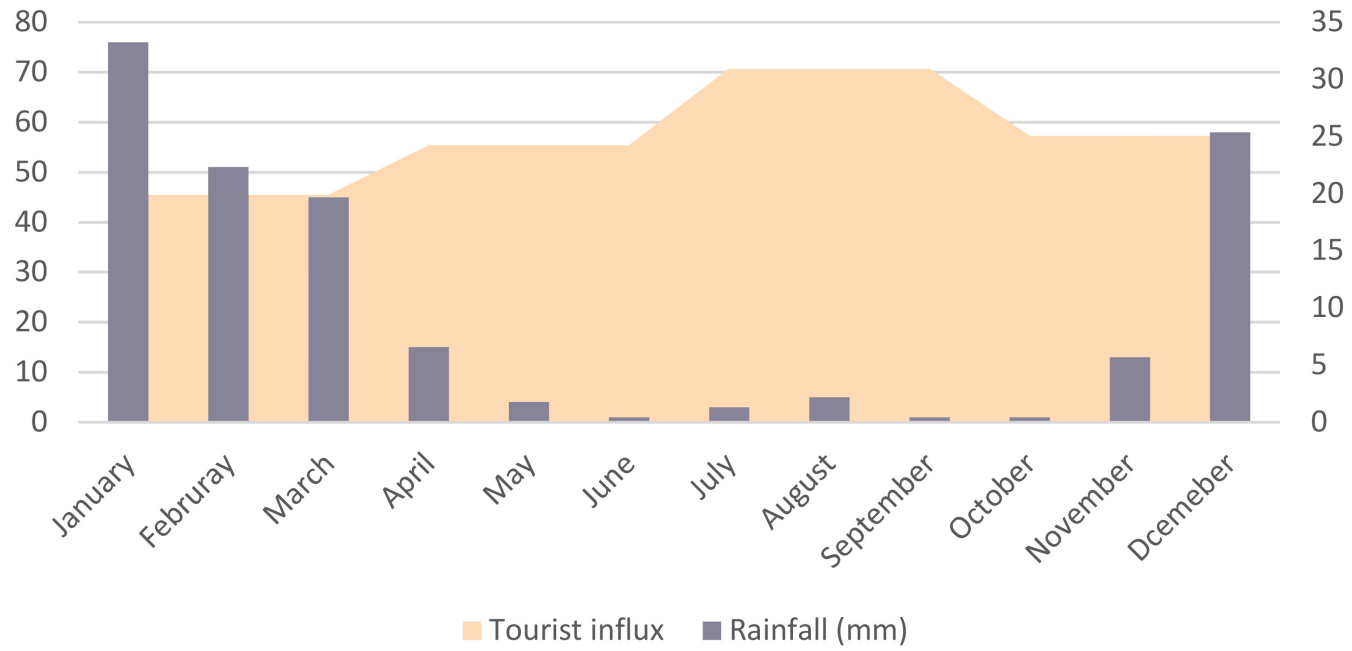



# PROBLEM STATEMENT

Urban water management challenge : Water quality considered as a binary entity

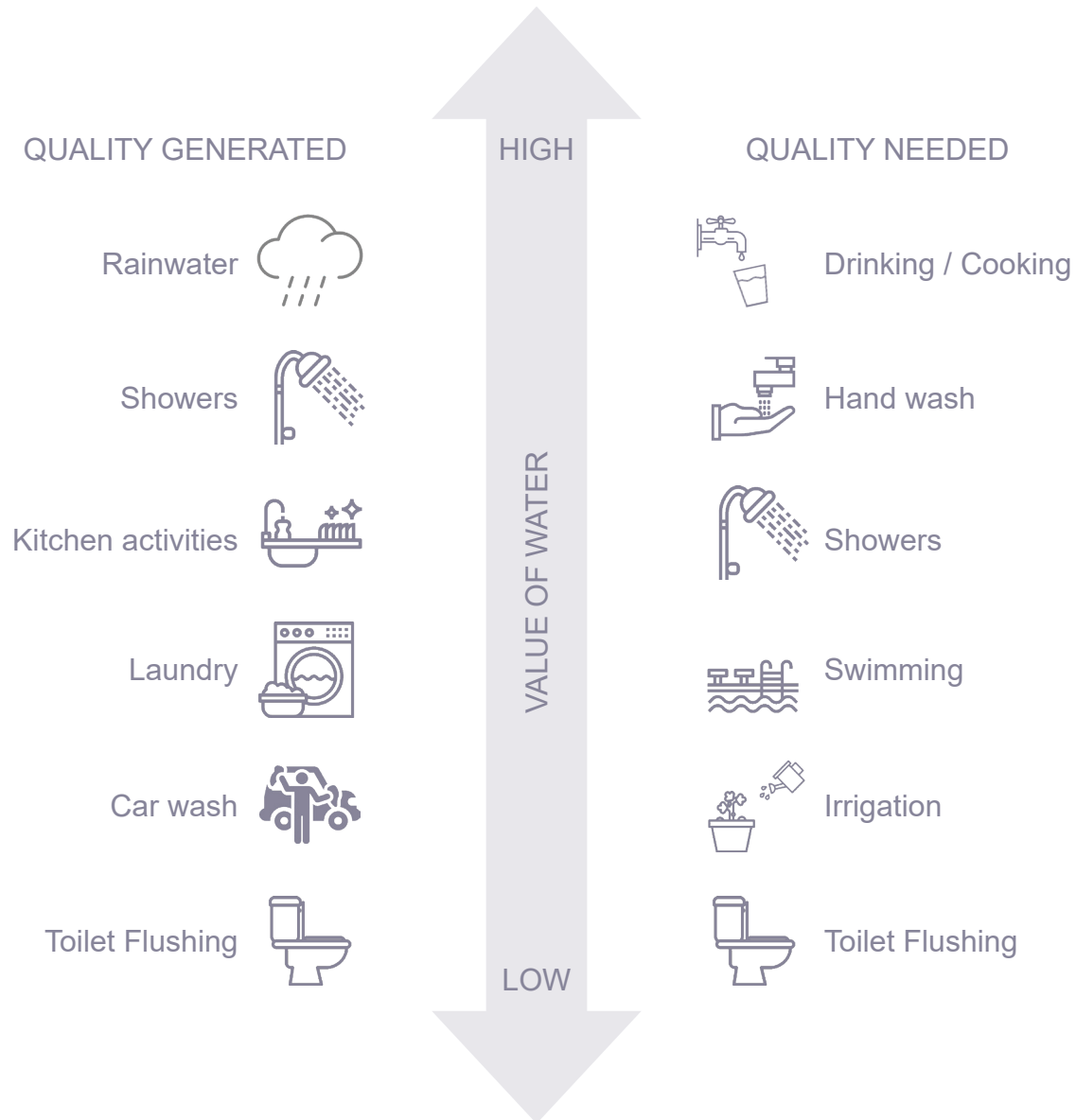

## RESEARCH QUESTION

What sustainable water management scheme is possible for the Negin project, and what is its potential in the built environment?

## RESEARCH QUESTION

What sustainable water management scheme is possible for the Negin project, and what is its potential in the built environment?



Water statistics and technologies

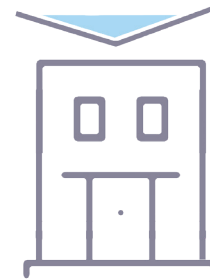

Impact on built form

SITE LOCATION - 23.4 Km from city of Firoozabad

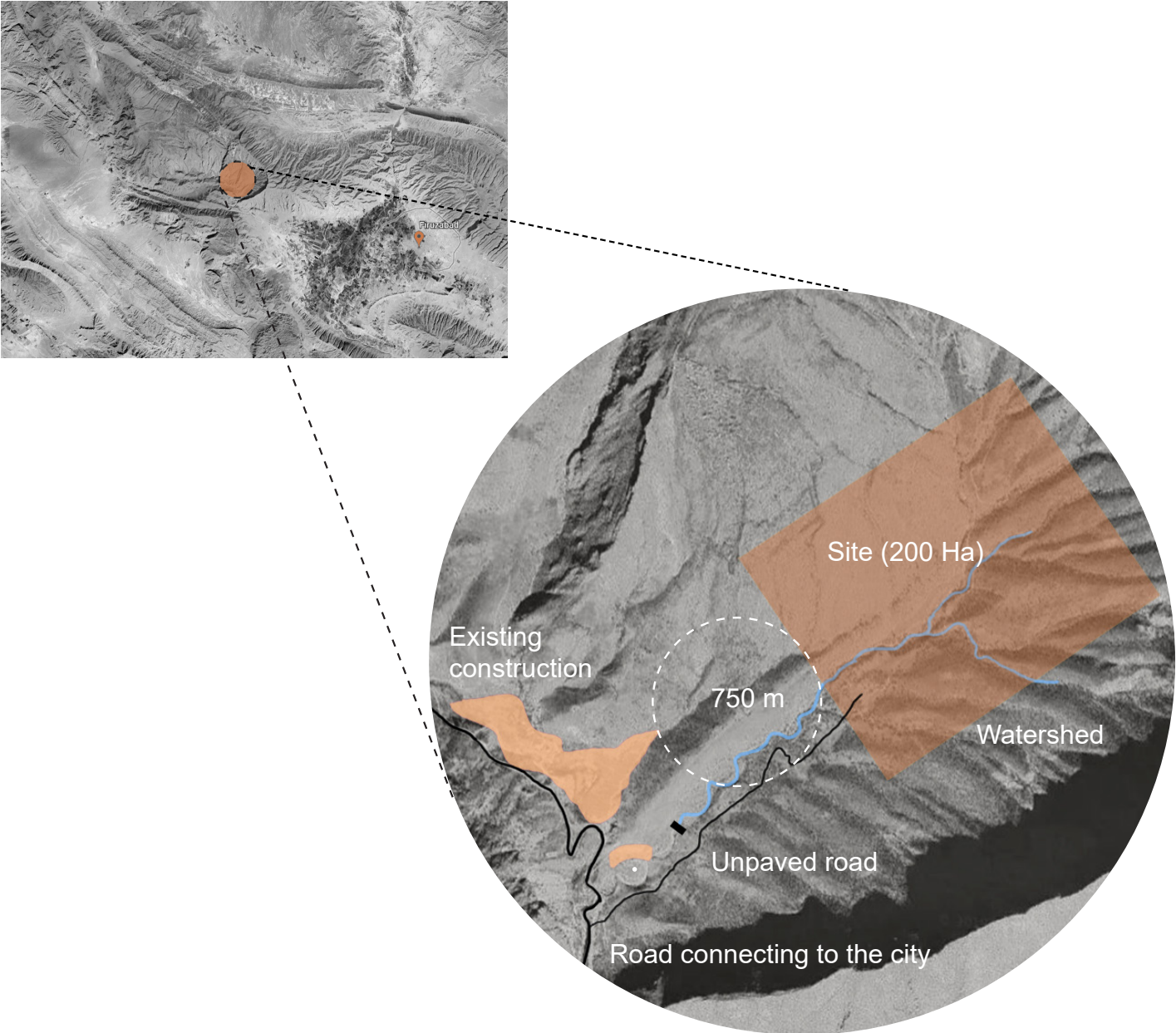



# RELATIVITY CHART

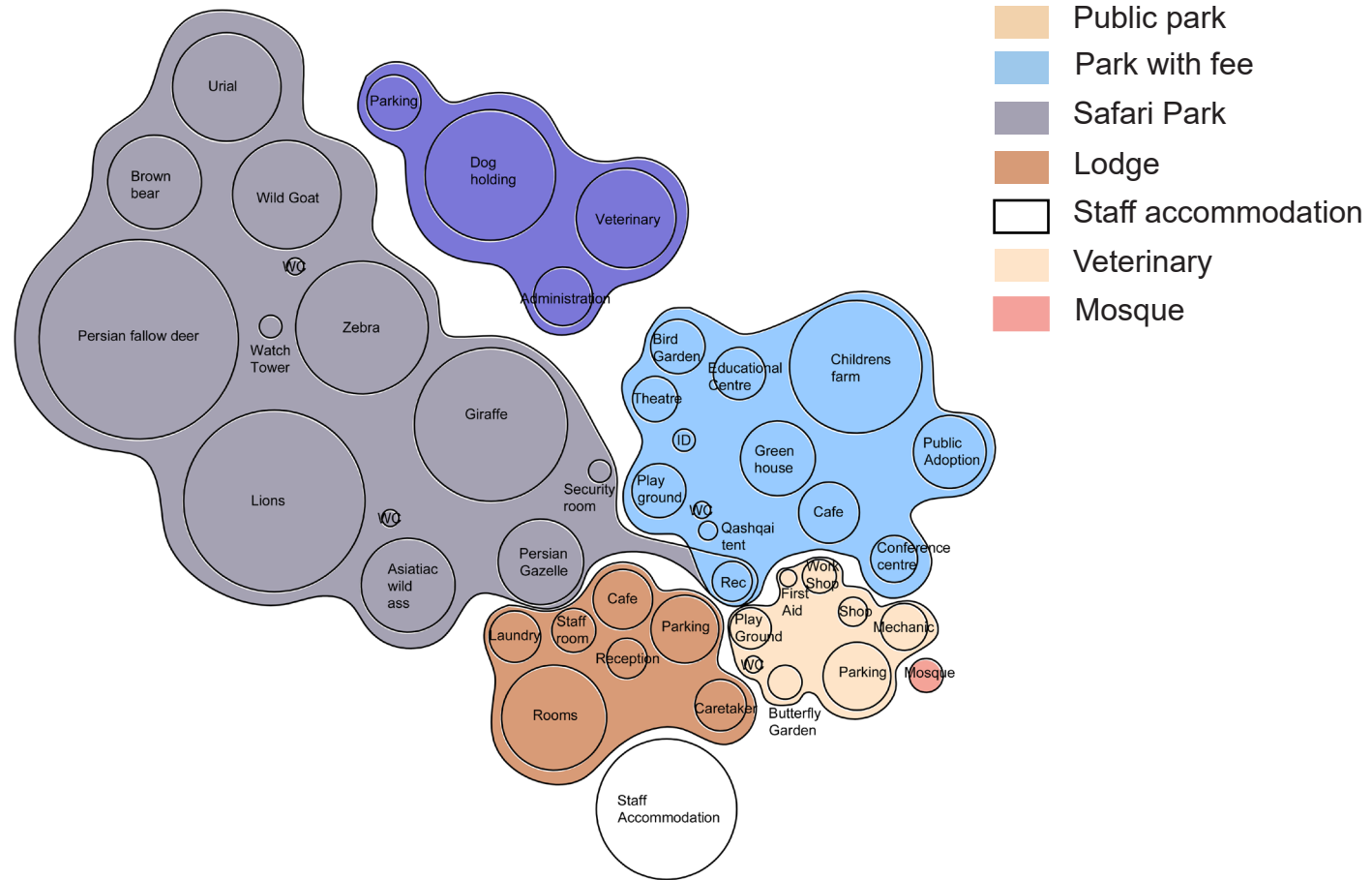

# WATER STATISTICS

Daily water demand : 19m<sup>3</sup>

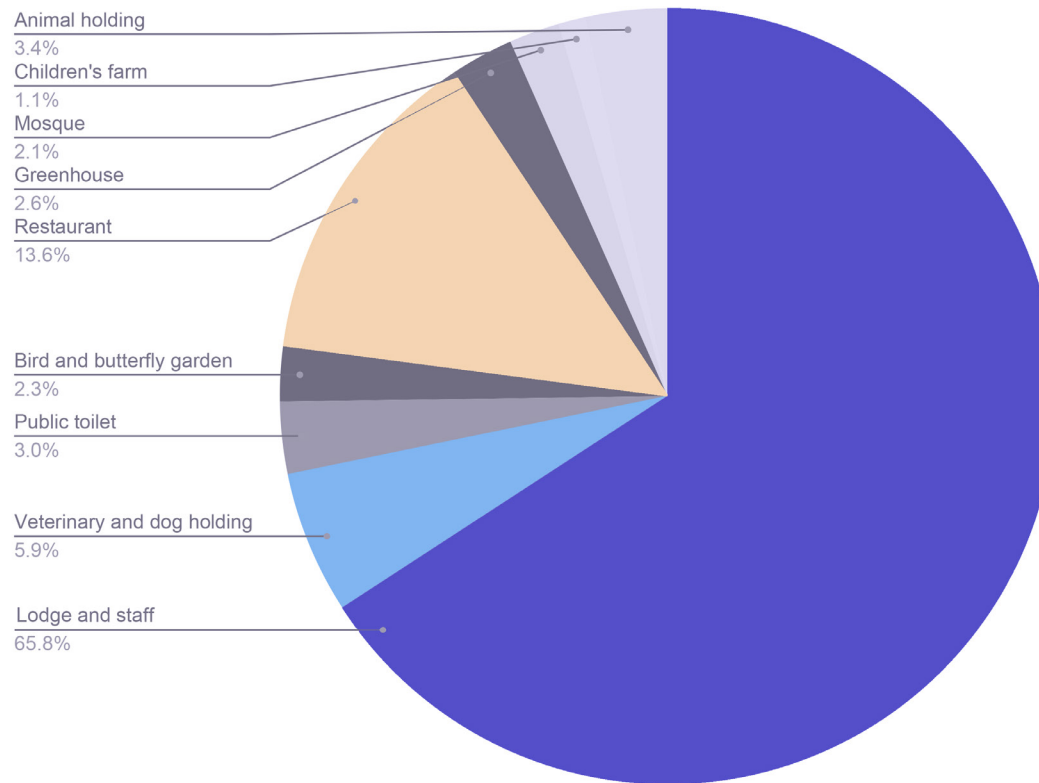

# WATER STATISTICS

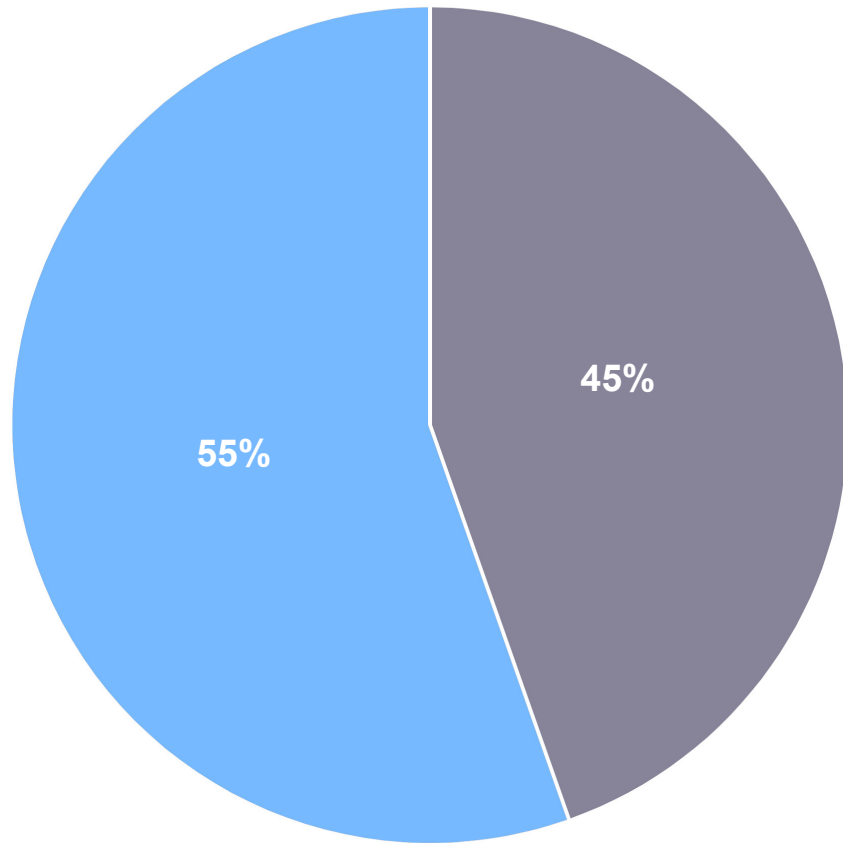

● Potable water consumption    ● Non potable water consumption

Potable water demand  
(Consumptive use)



Non- Potable water demand  
(Non-Consumptive use)



# WATER STATISTICS

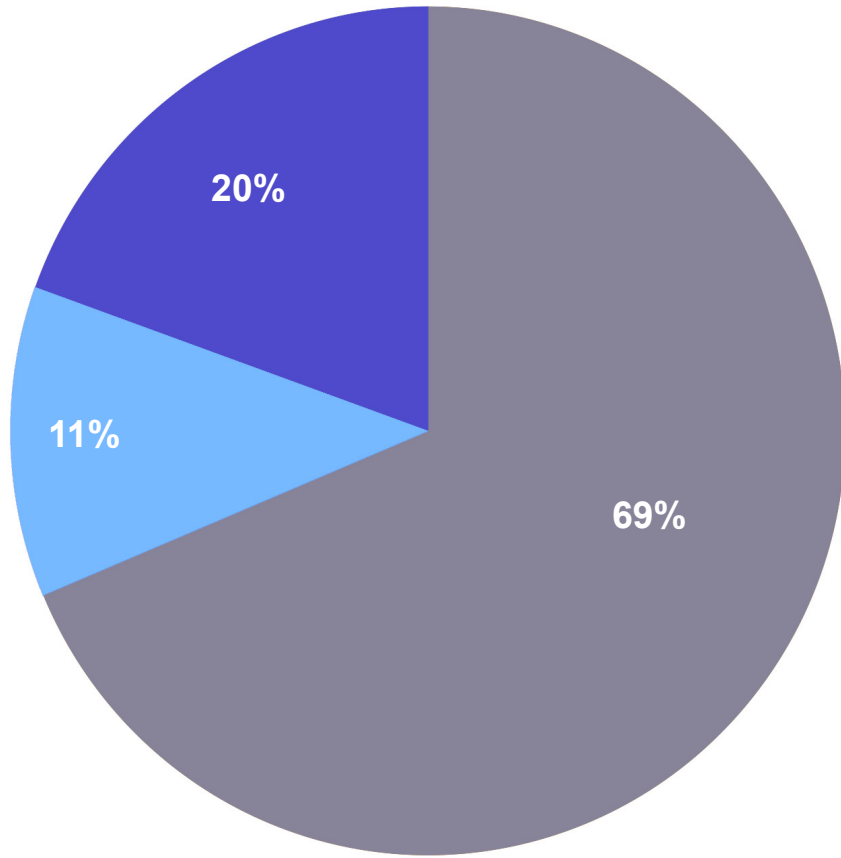

● Light greywater    ● Dark greywater    ● Black water

Light grey water



Dark grey water



Black water



# WATER TECHNOLOGIES - Sourcing water

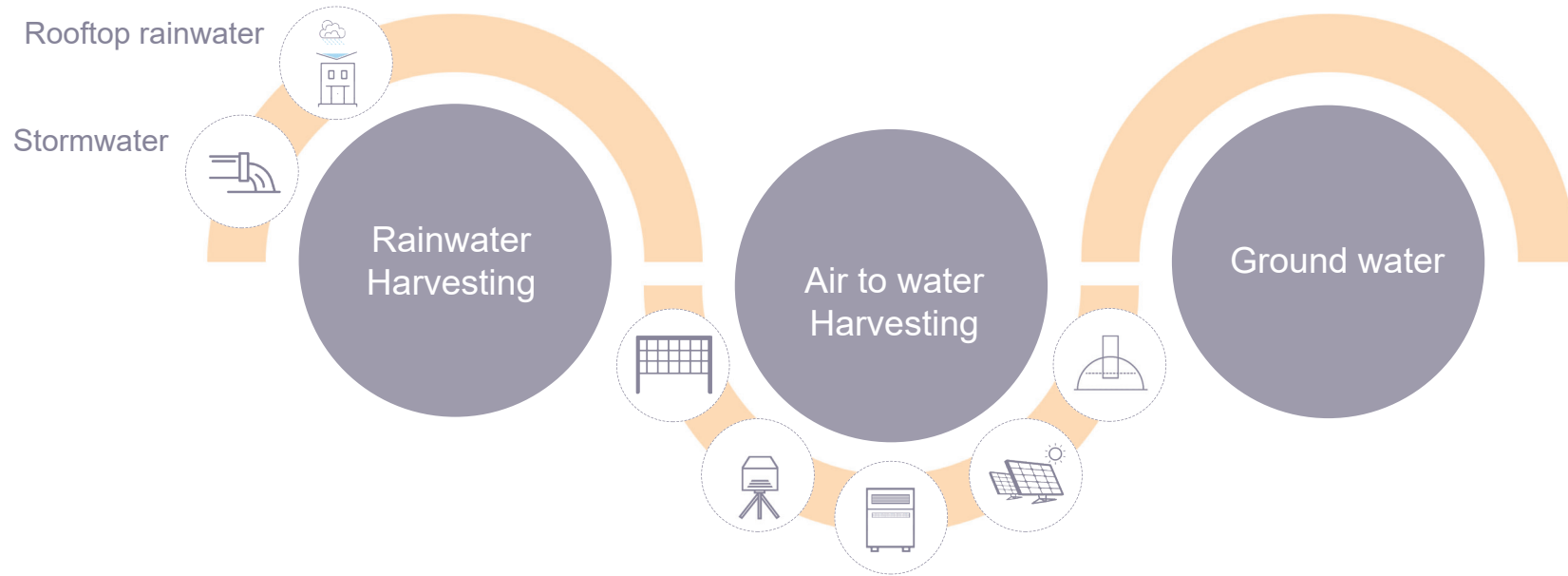

# WATER TECHNOLOGIES - Sourcing water

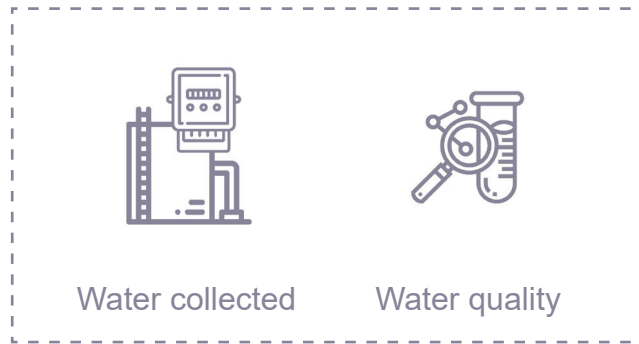
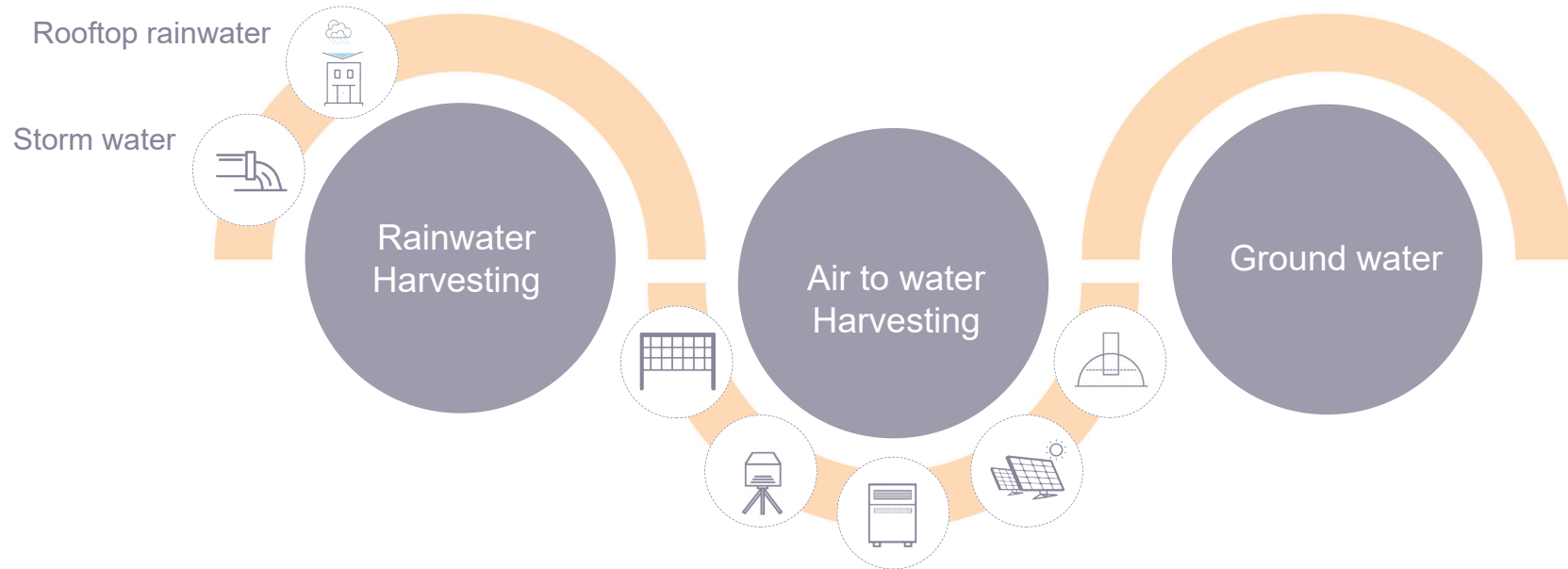



# WATER TECHNOLOGIES - Rooftop rainwater

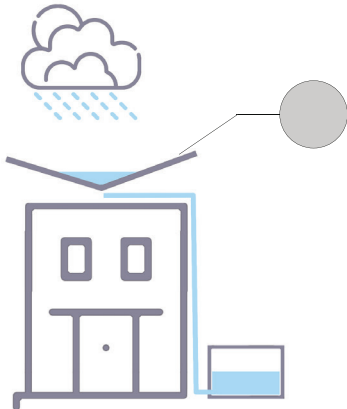

A metal roof installed at an angle has the highest run off coefficient and provides best quality of water

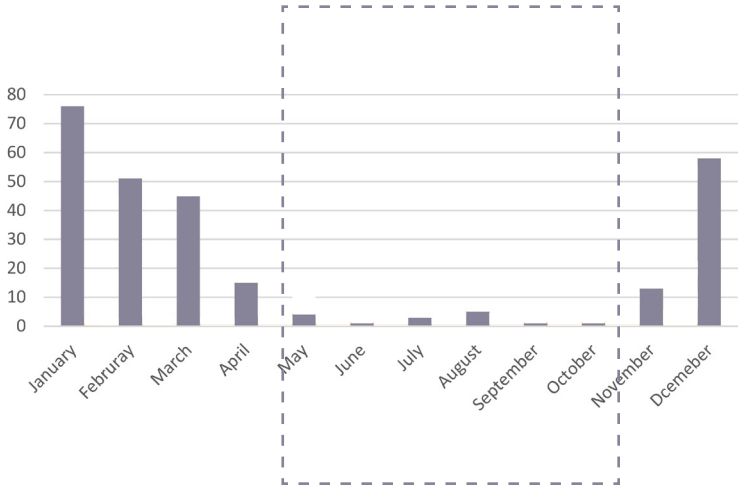

Requires storage of water for 6 months

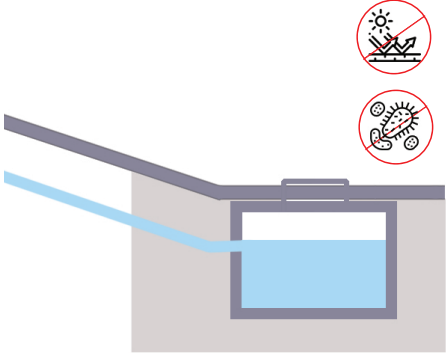

Underground storage of water avoids contamination of water and growth of organisms

# WATER TECHNOLOGIES - Sourcing water

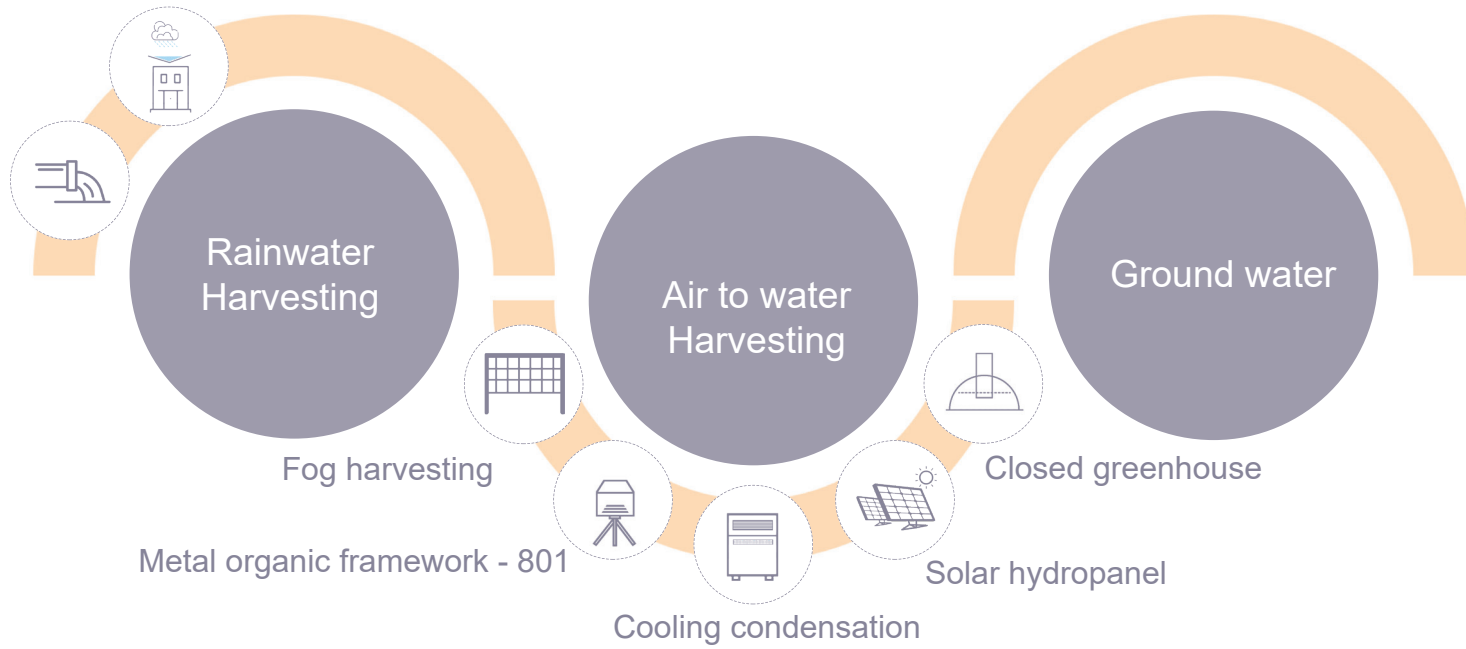

# WATER TECHNOLOGIES - Sourcing water

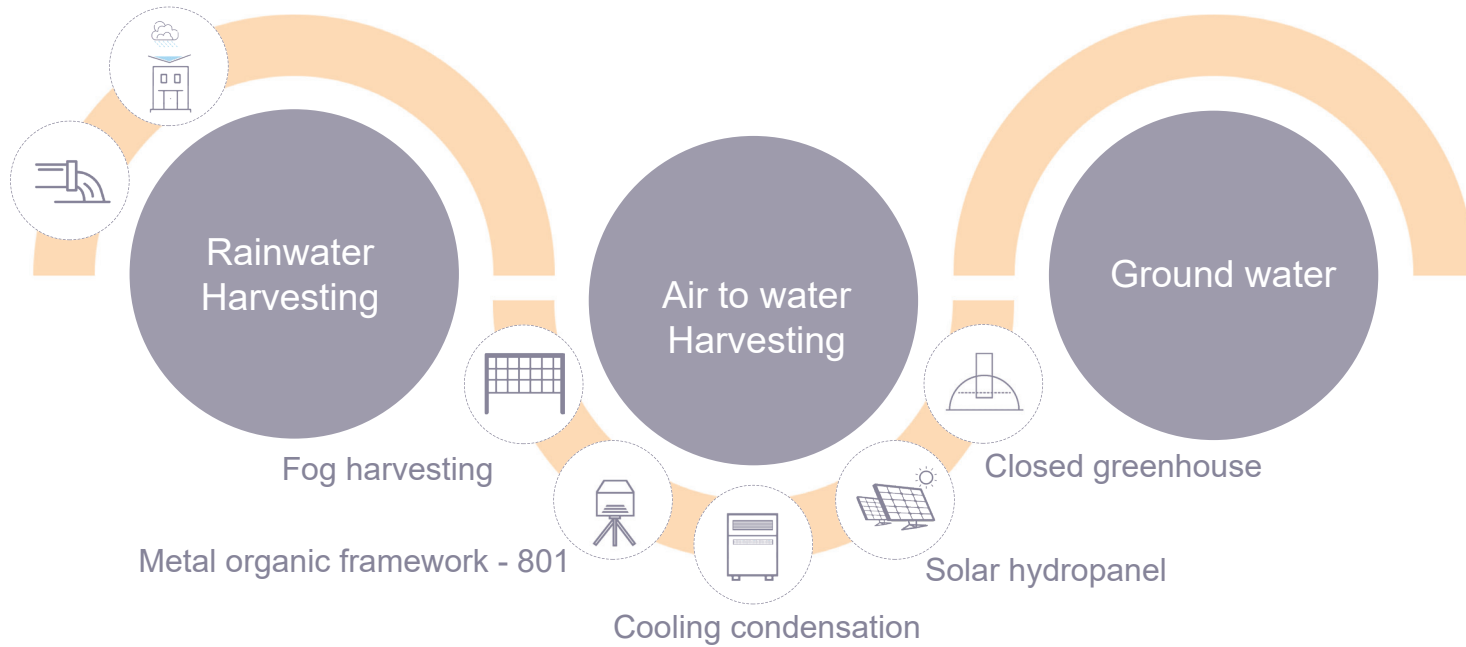

# WATER TECHNOLOGIES - Closed greenhouse

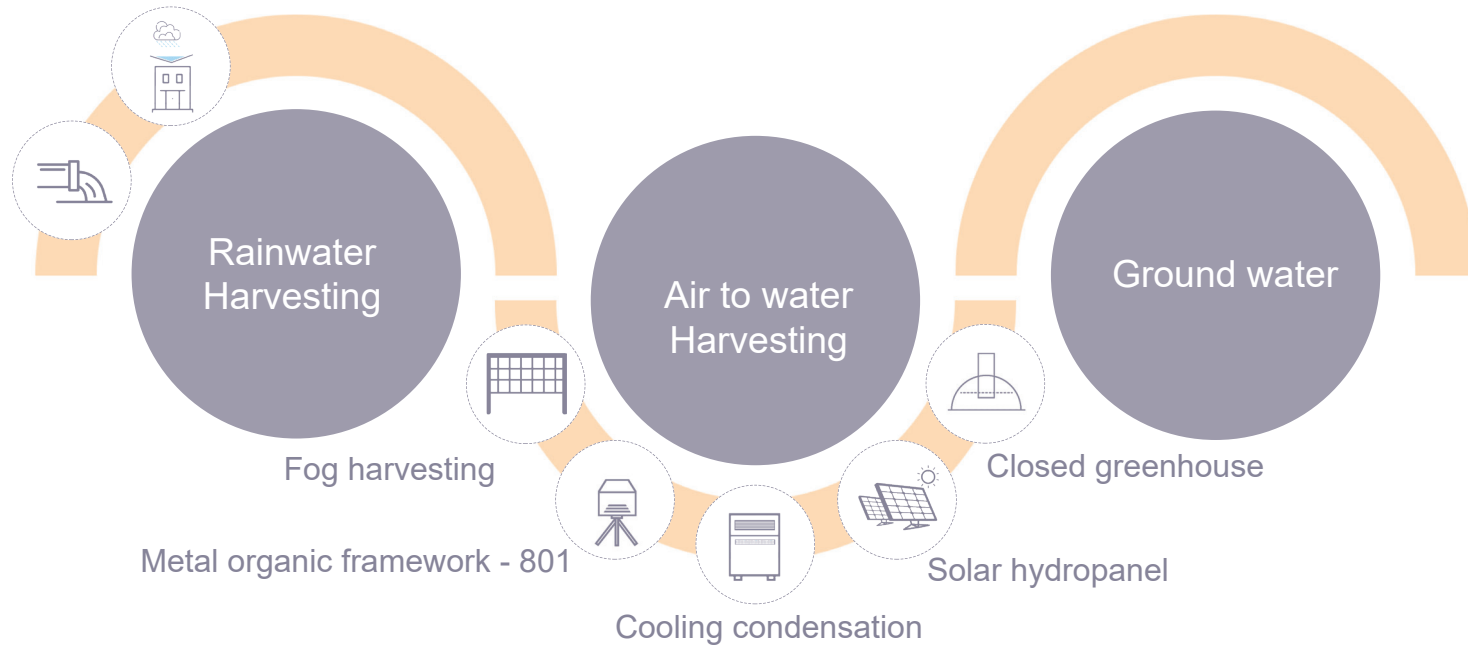

# WATER TECHNOLOGIES - Closed greenhouse

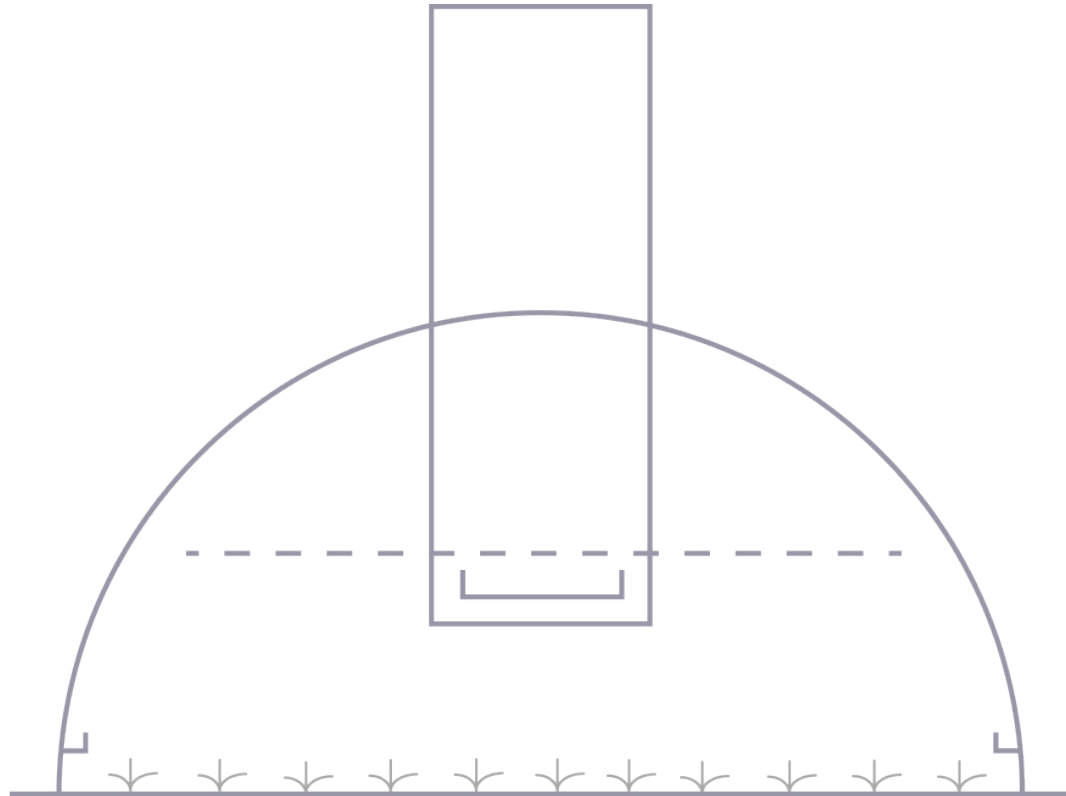

# WATER TECHNOLOGIES - Parts of closed greenhouse

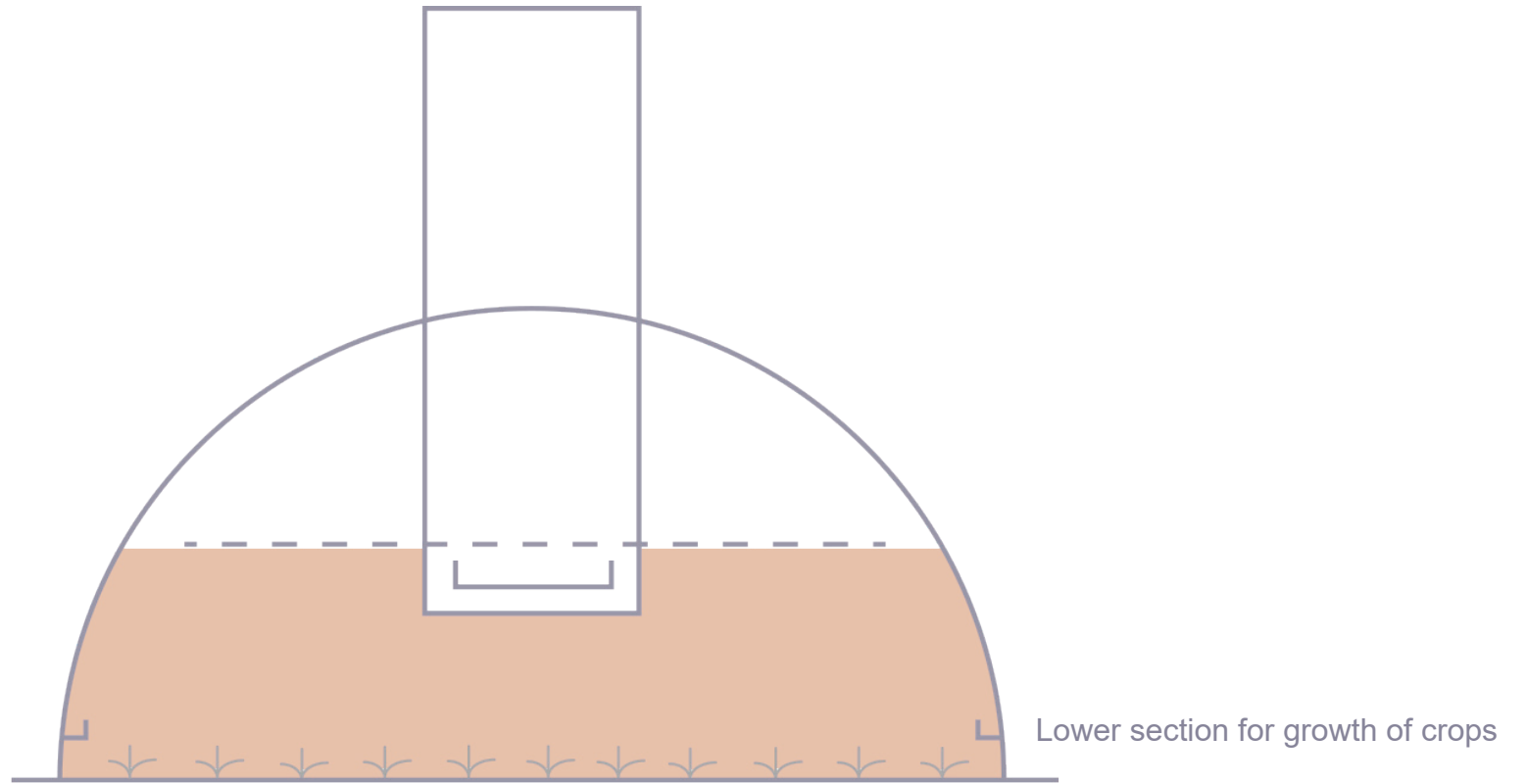

# WATER TECHNOLOGIES - Parts of closed greenhouse

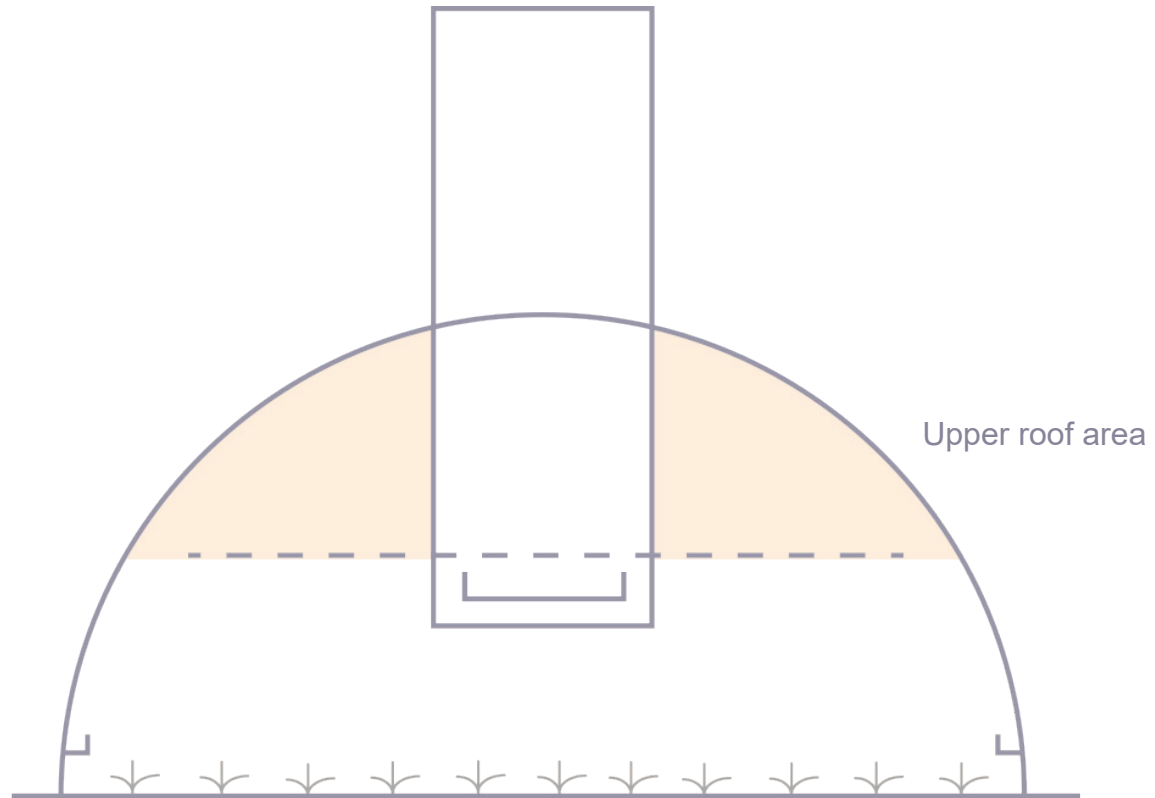

# WATER TECHNOLOGIES - Parts of closed greenhouse

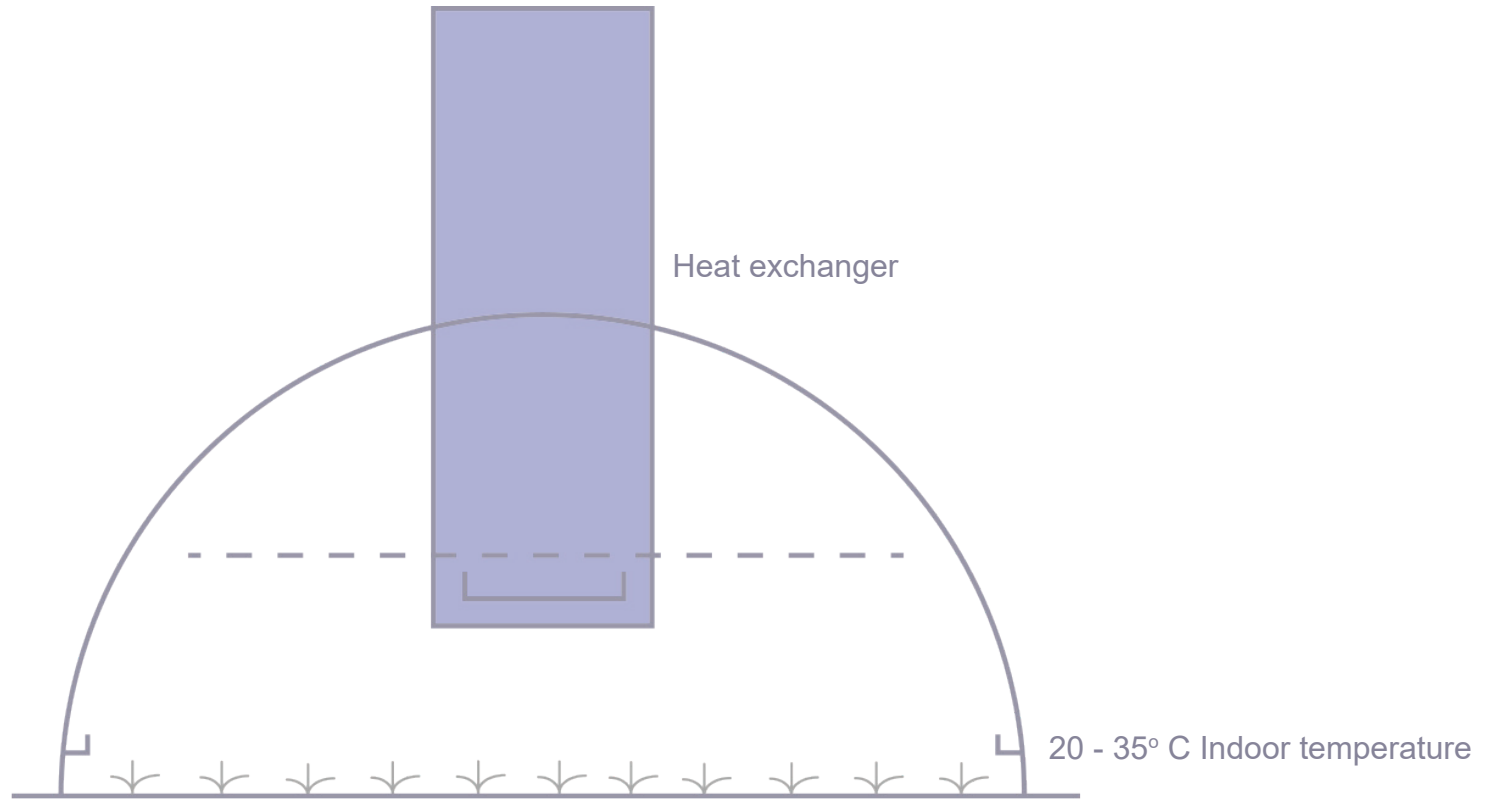



# WATER TECHNOLOGIES - Closed greenhouse

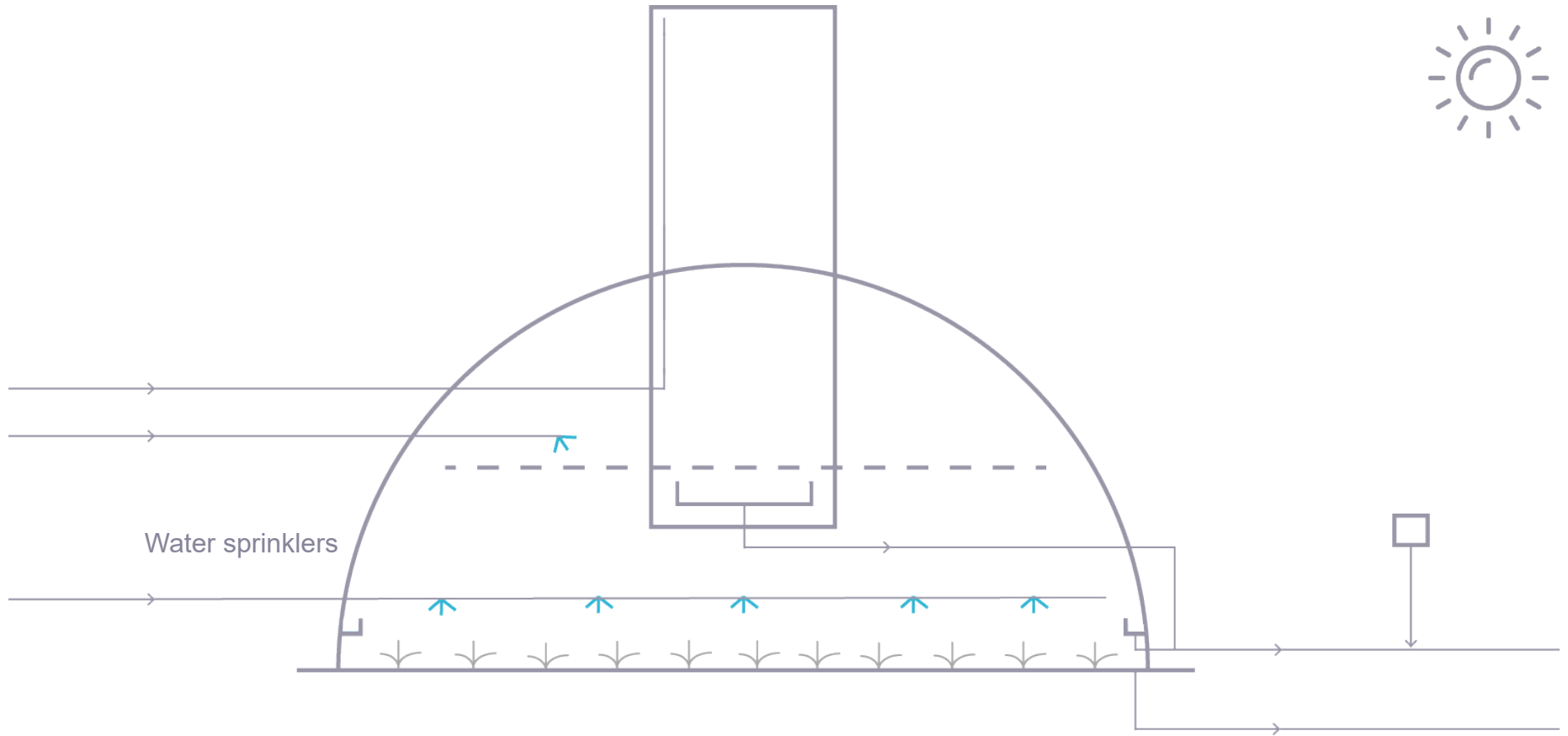

# WATER TECHNOLOGIES - Closed greenhouse

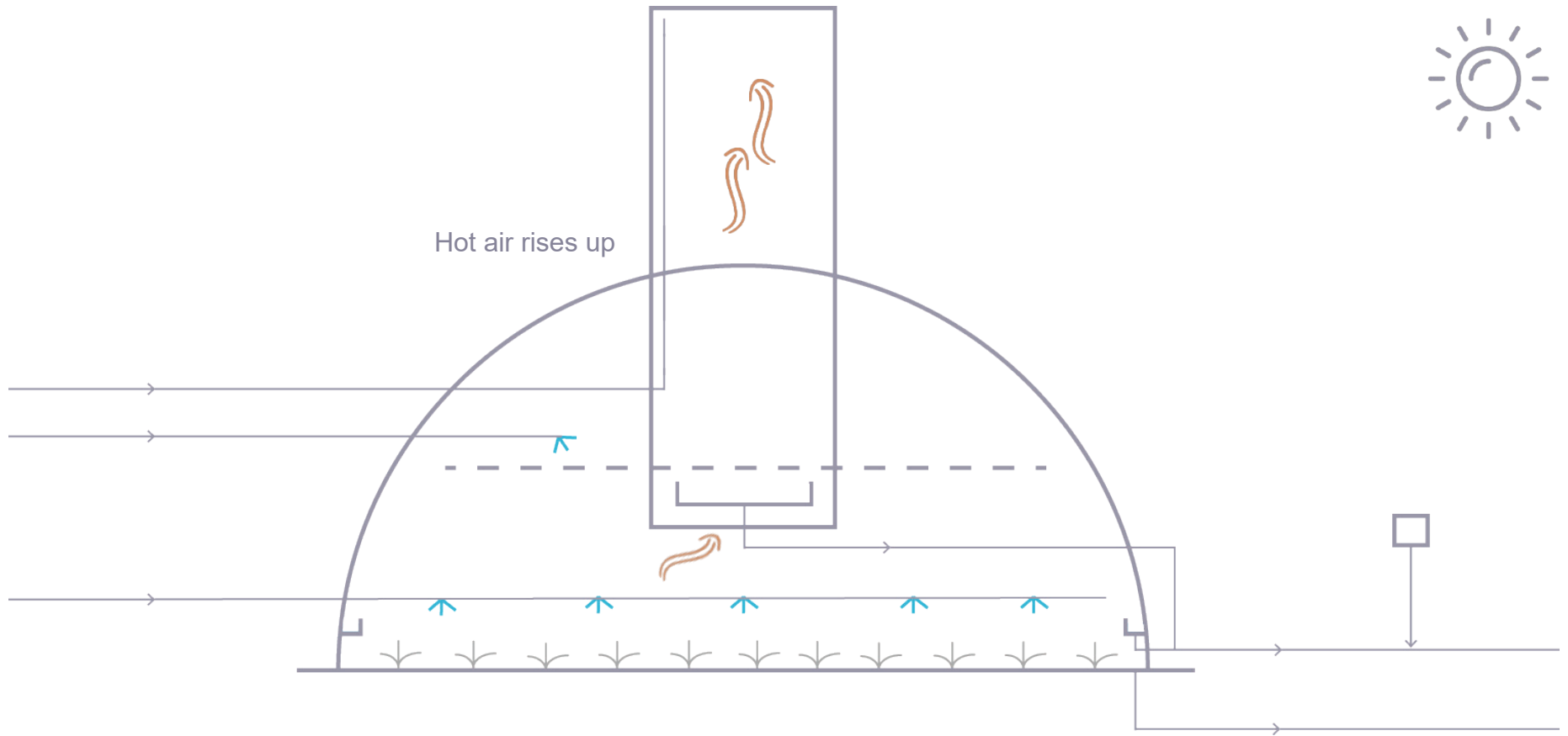

# WATER TECHNOLOGIES - Closed greenhouse

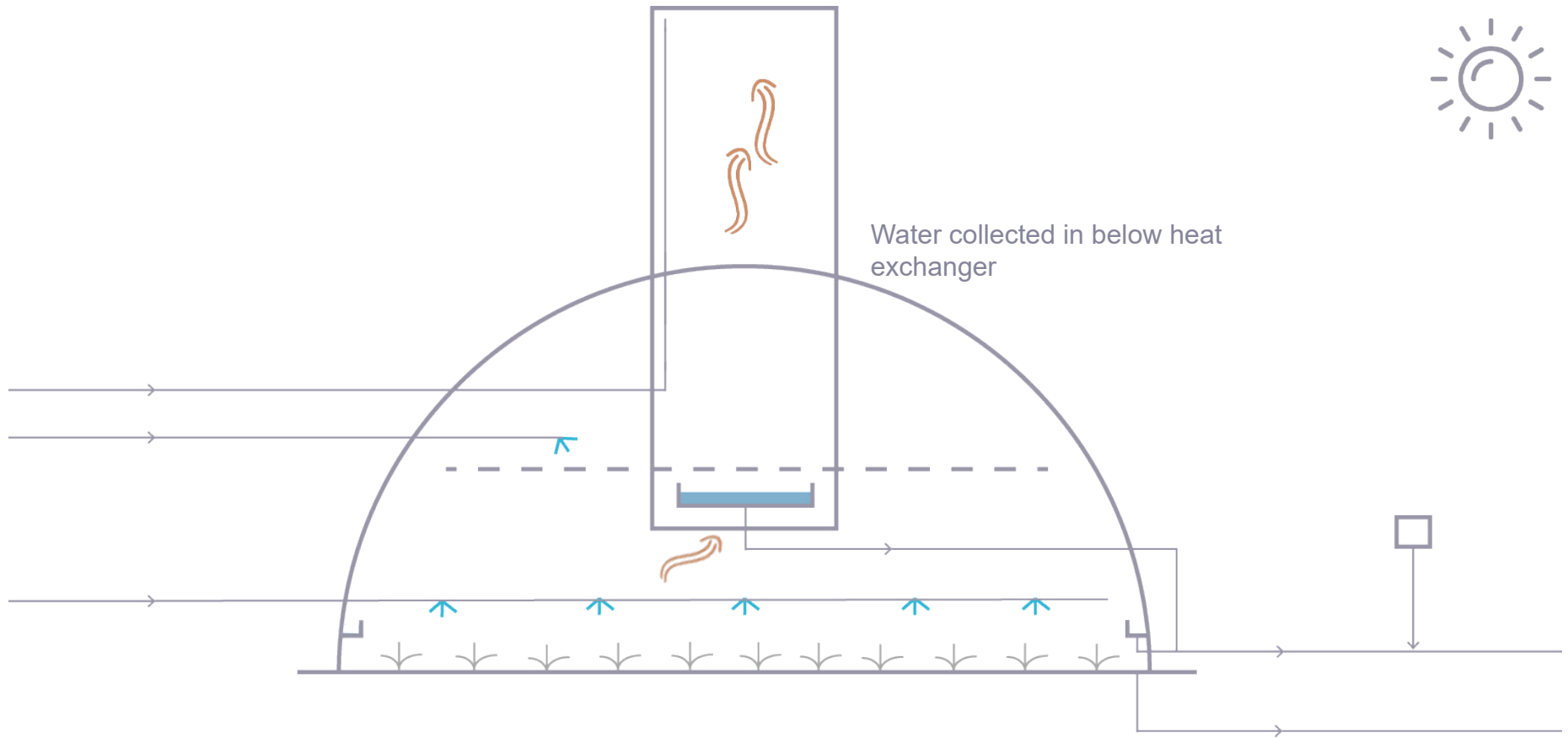

# WATER TECHNOLOGIES - Closed greenhouse

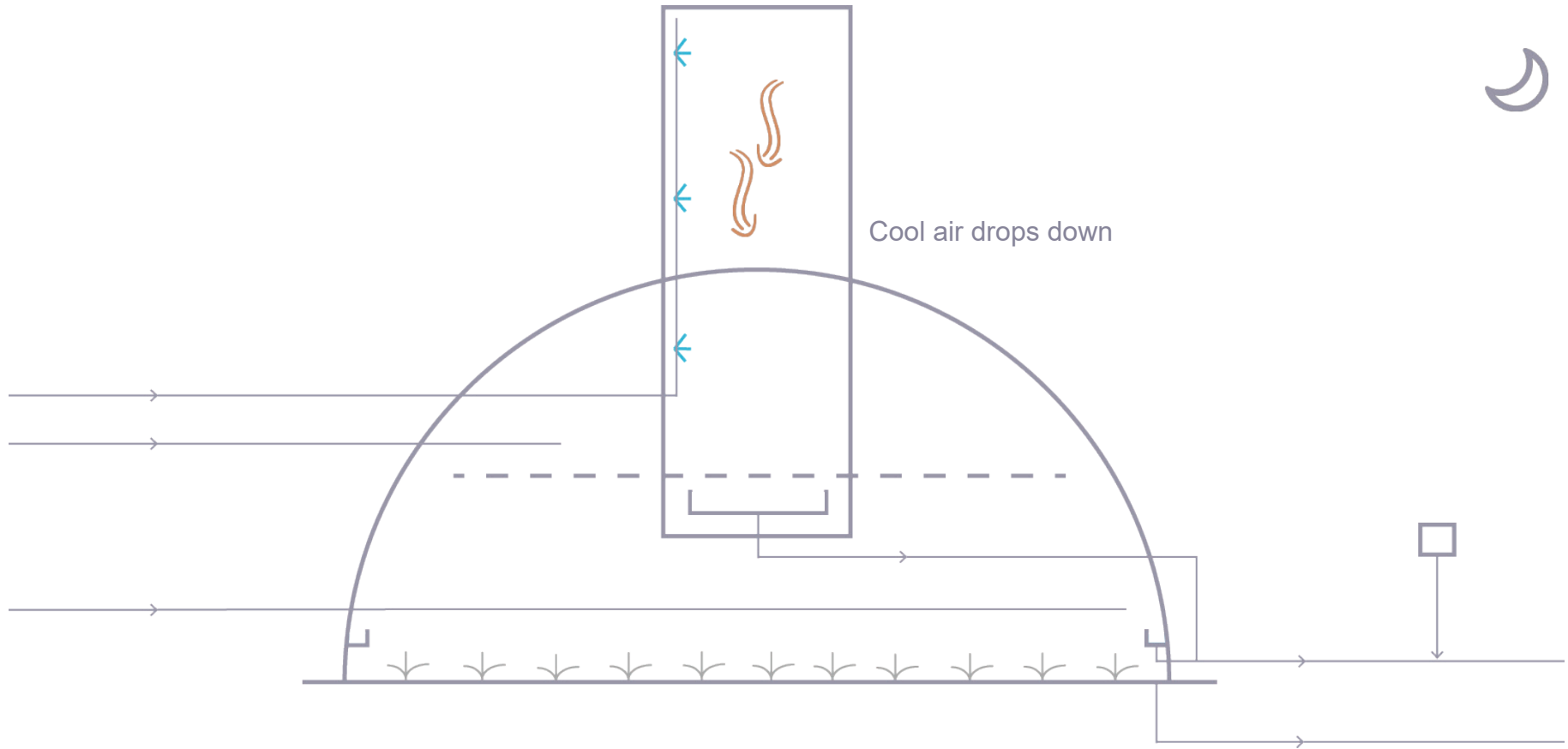

# WATER TECHNOLOGIES - Closed greenhouse

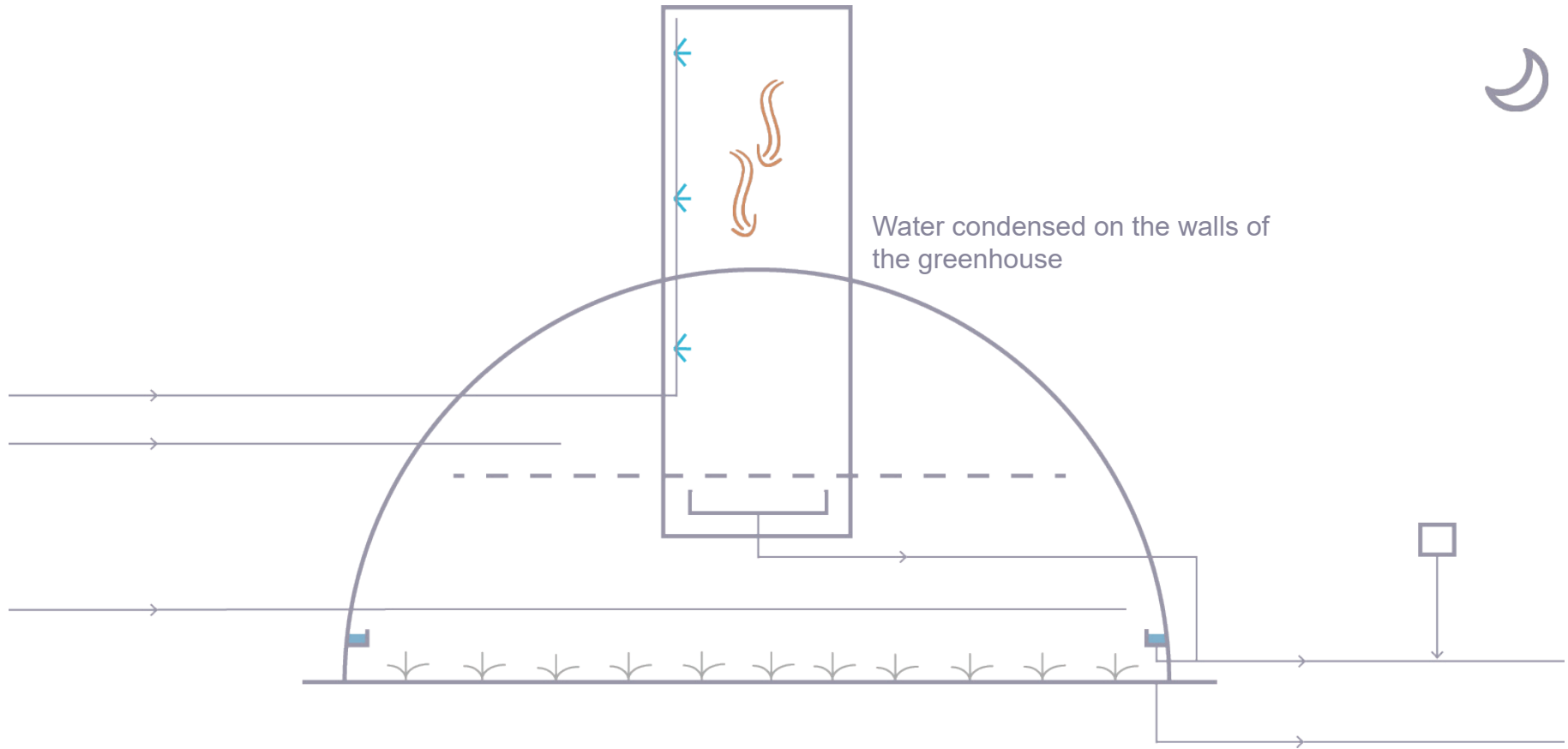

# WATER TECHNOLOGIES - Waste water treatment

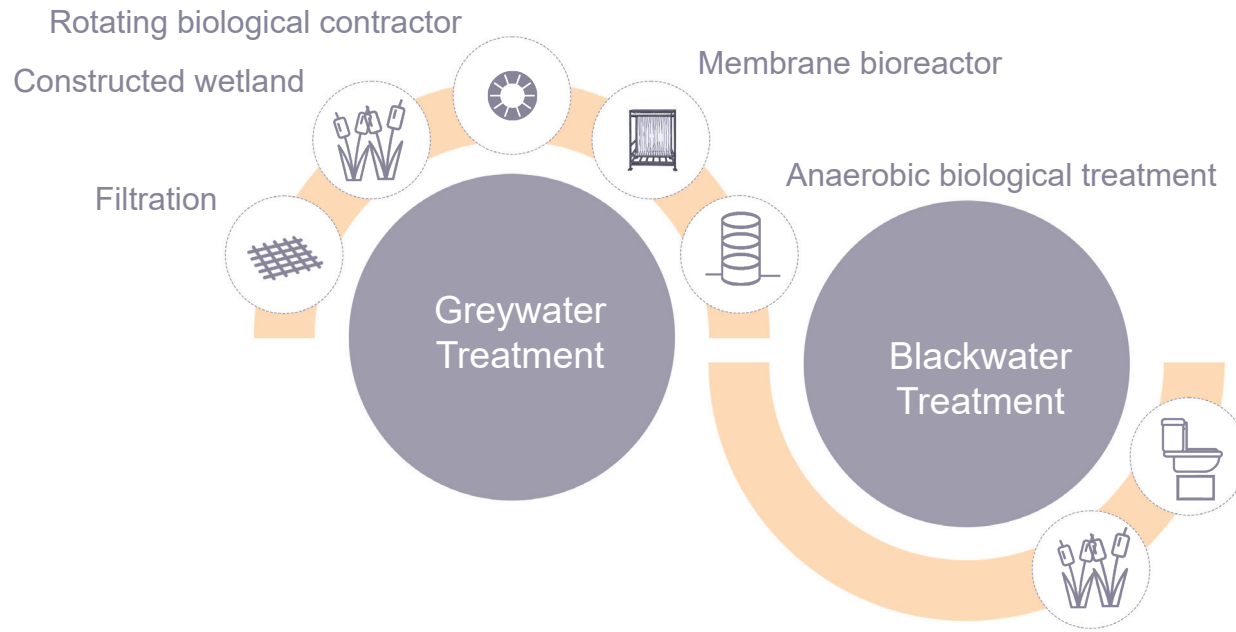

# WATER TECHNOLOGIES - Waste water treatment

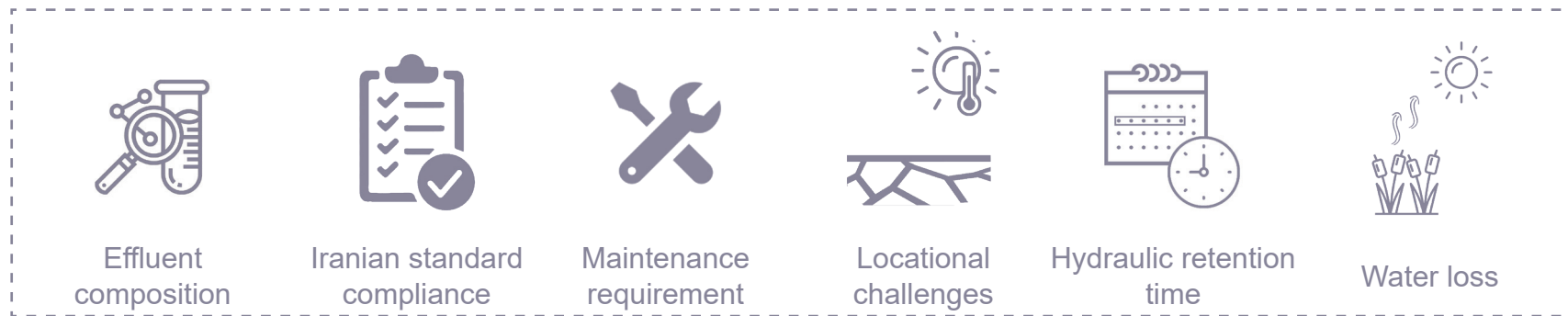
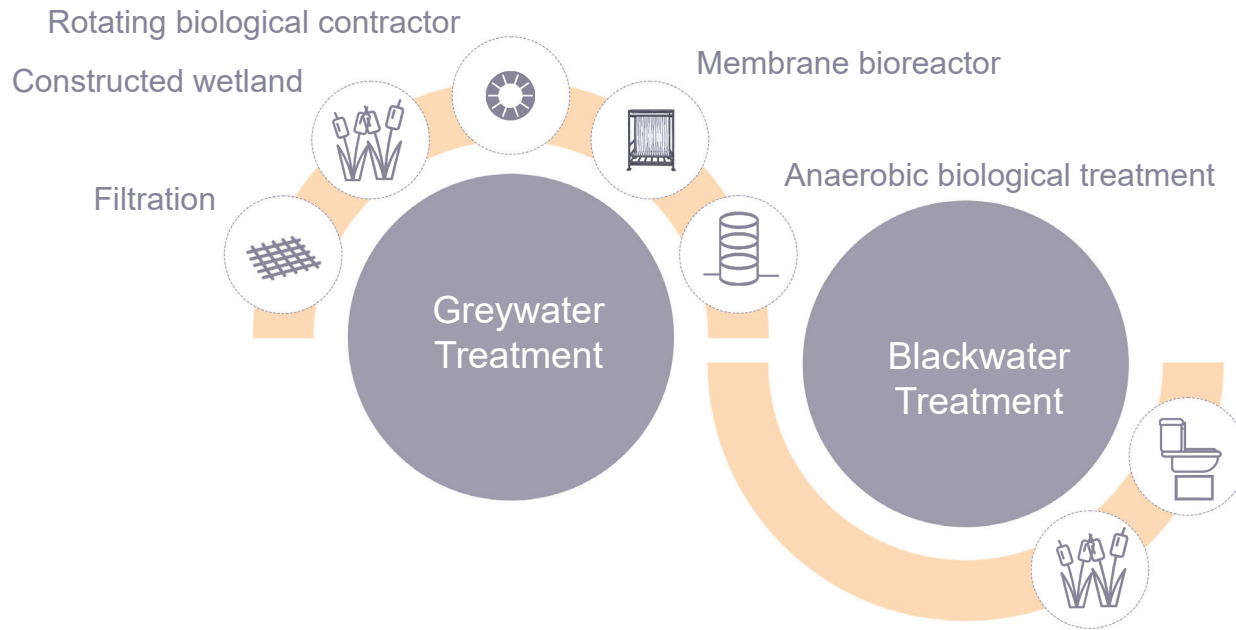

# WATER TECHNOLOGIES - Membrane bioreactor

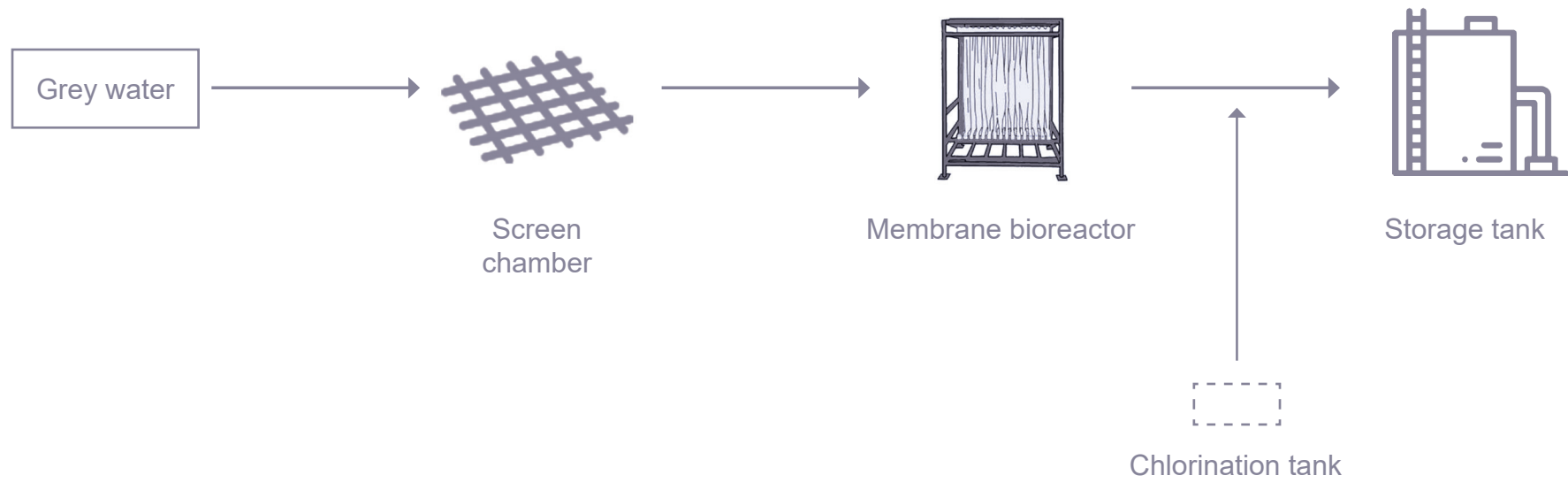



# WATER TECHNOLOGIES - Waste water treatment

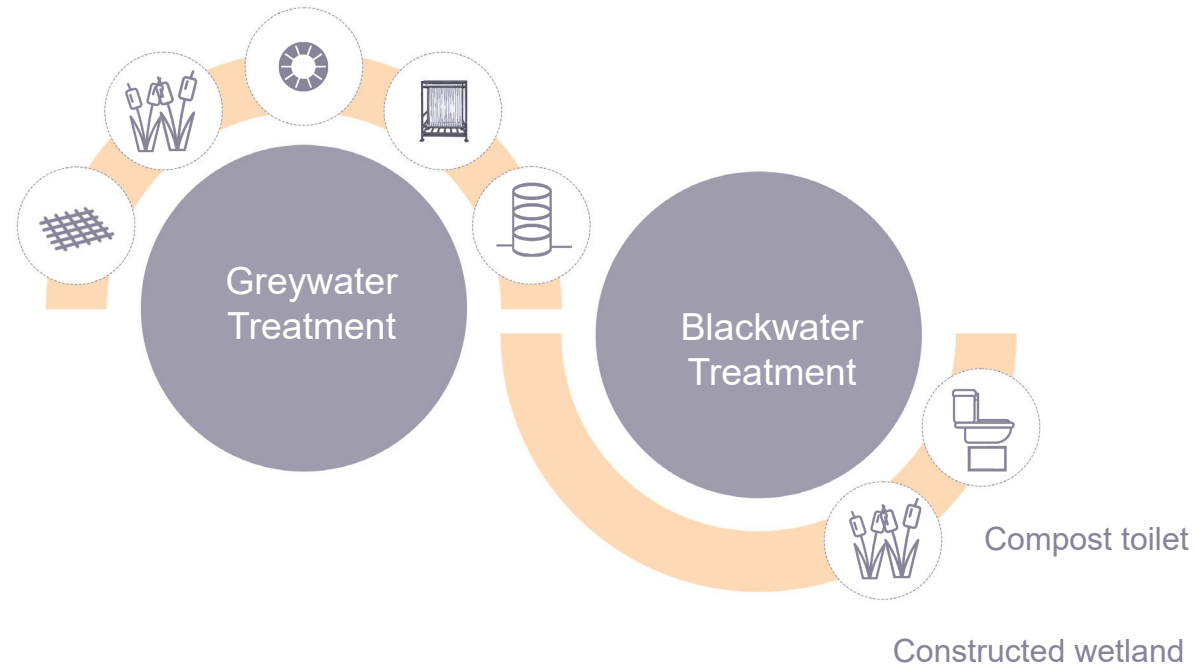

# WATER TECHNOLOGIES - Waste water treatment

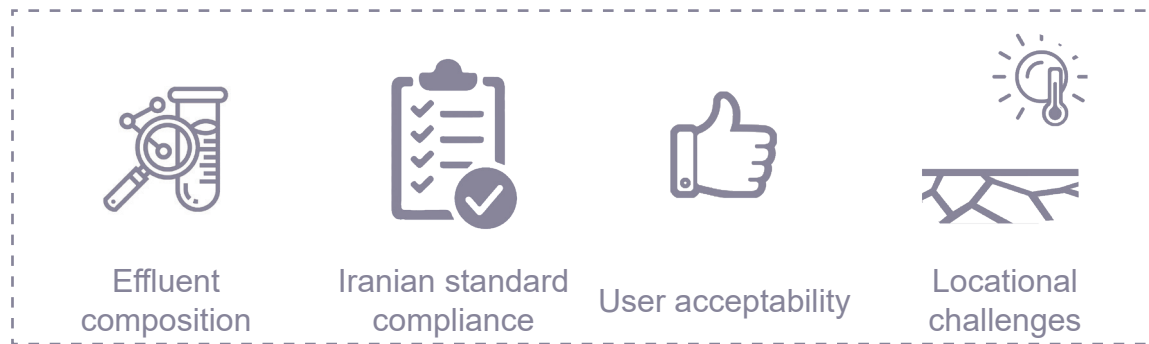
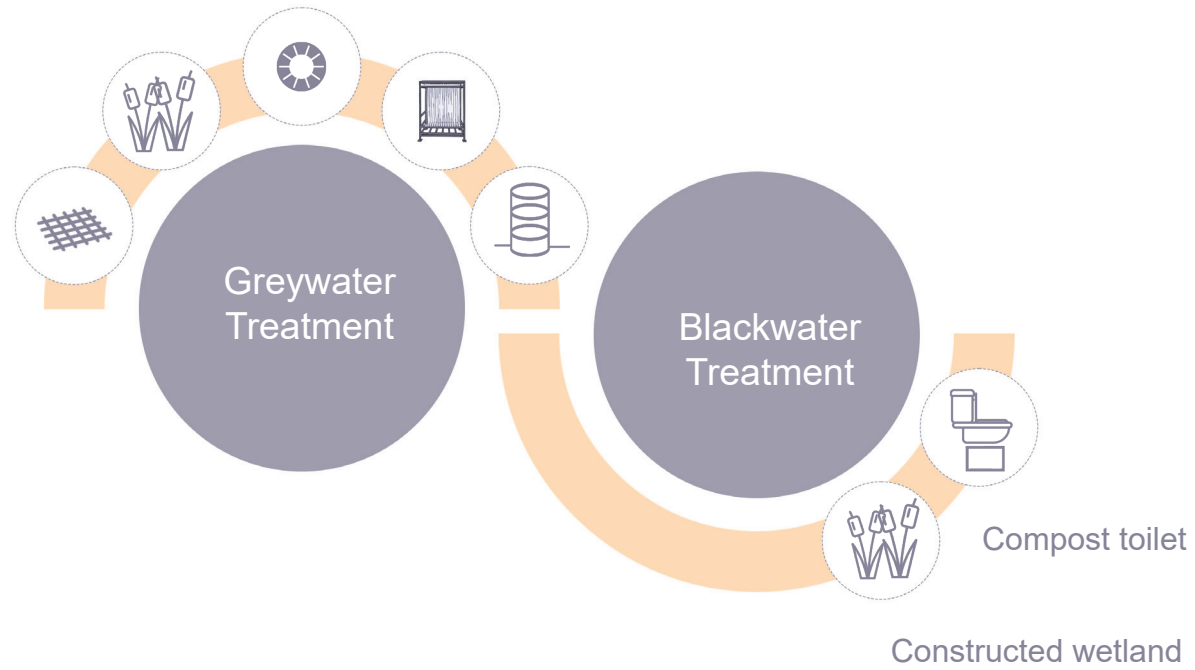

# WATER TECHNOLOGIES - Constructed wetland

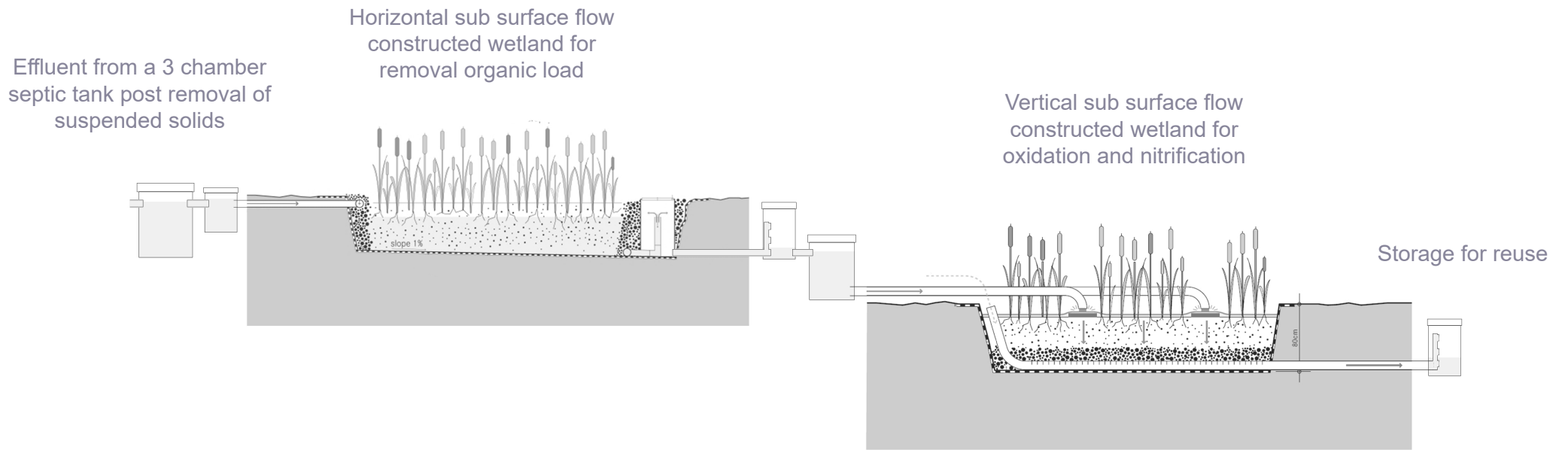

# Water management scheme - concept

Sourced Water quality

Water quality demand

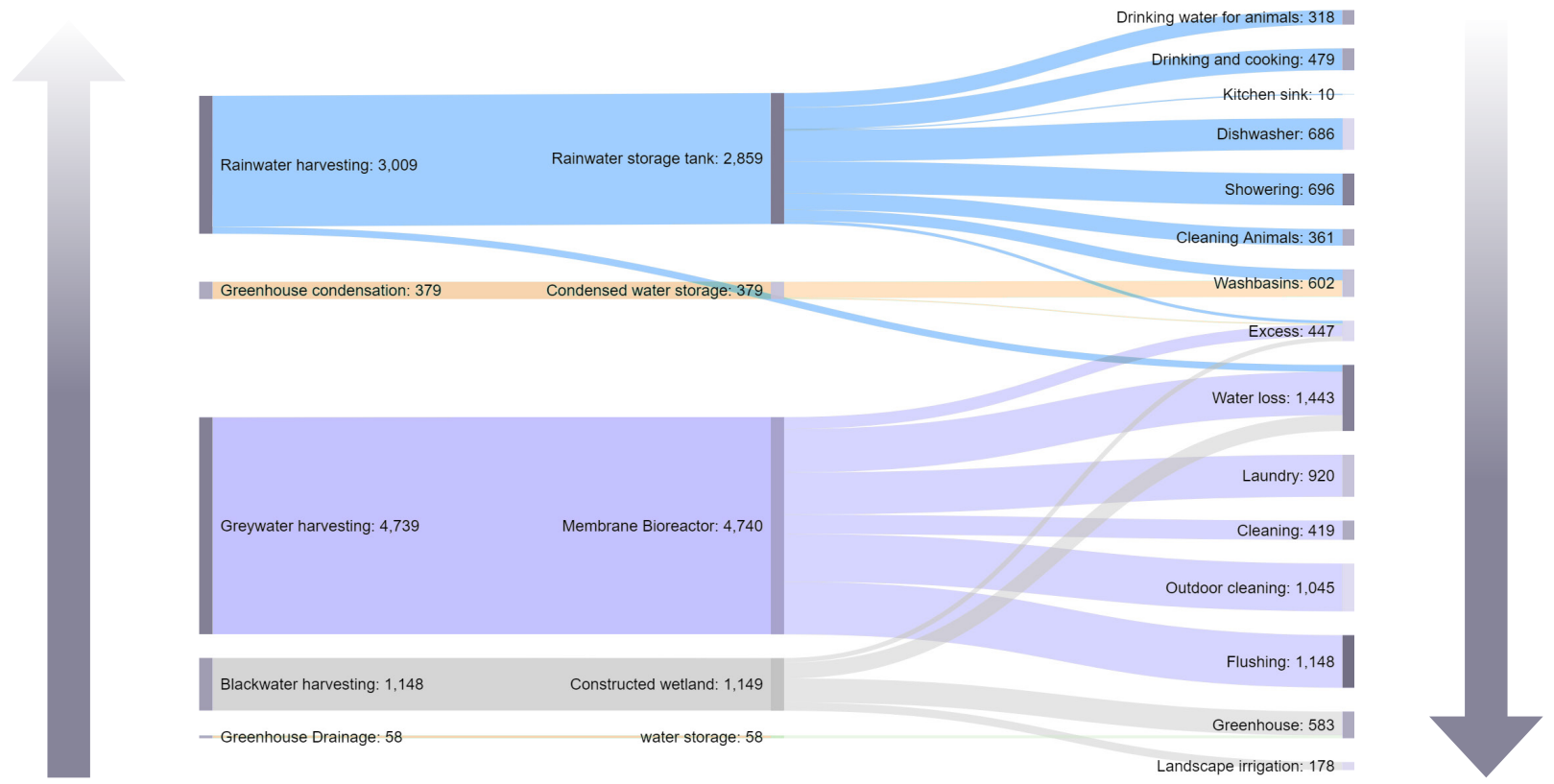

# Water management scheme - Quantified water demand

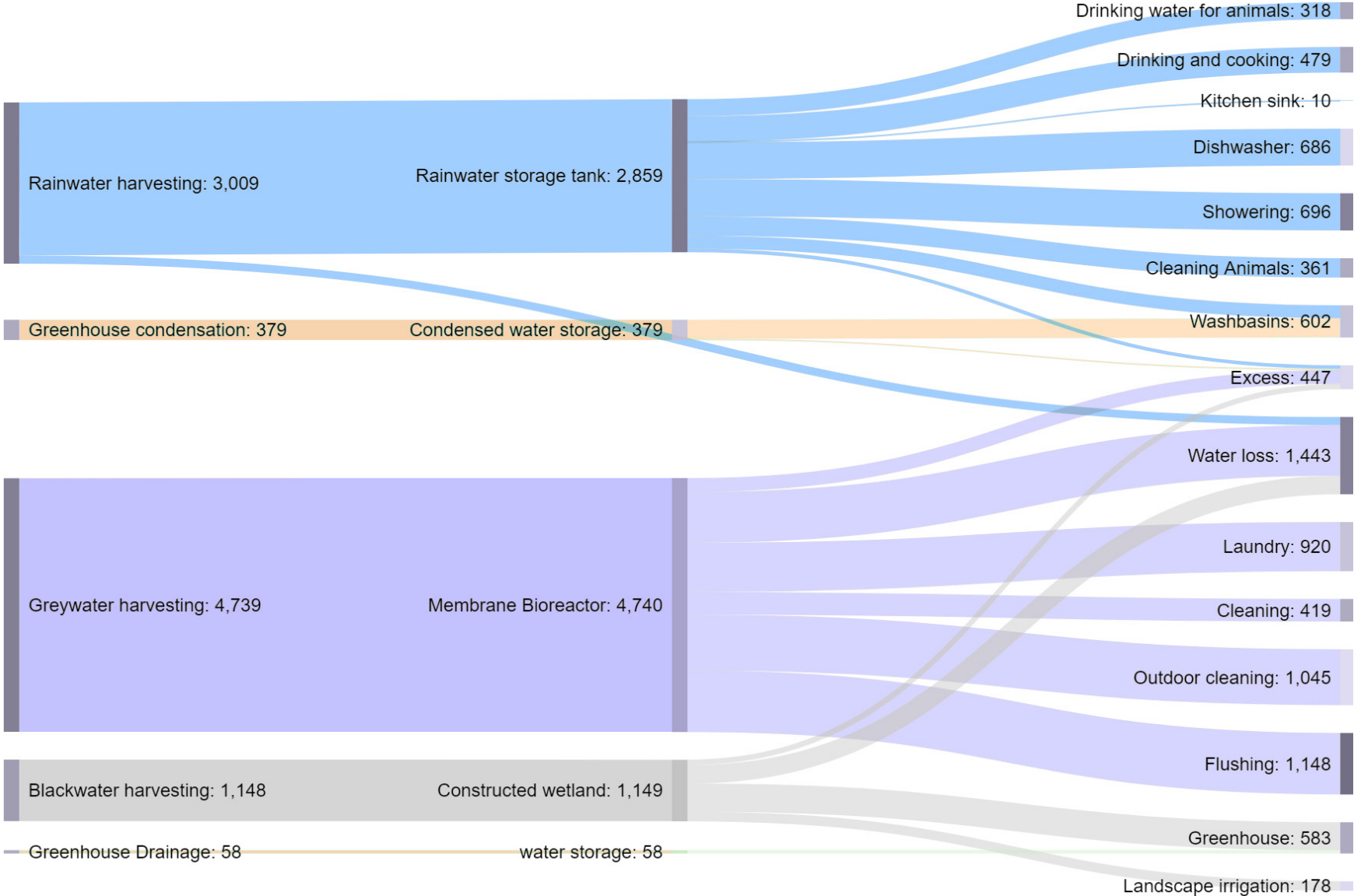

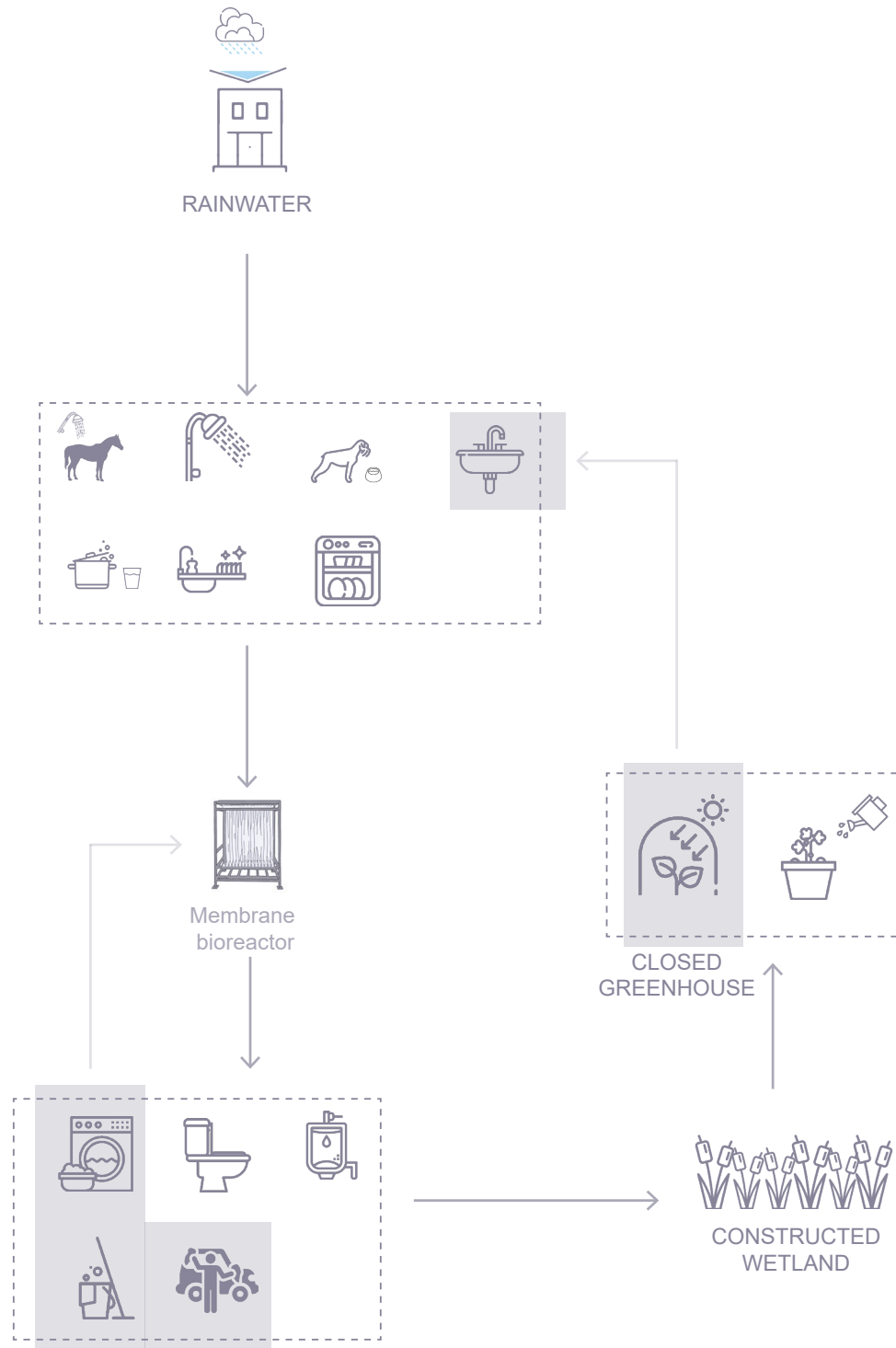



# Site plan



# Closed greenhouse



## Closed greenhouse



Promote participation  
of local community



Waste water  
treatment and reuse



Production of  
Non-native  
vegetables



Economic generator



Water conservation

# Rainwater harvesting



## Rainwater harvesting - Roof design

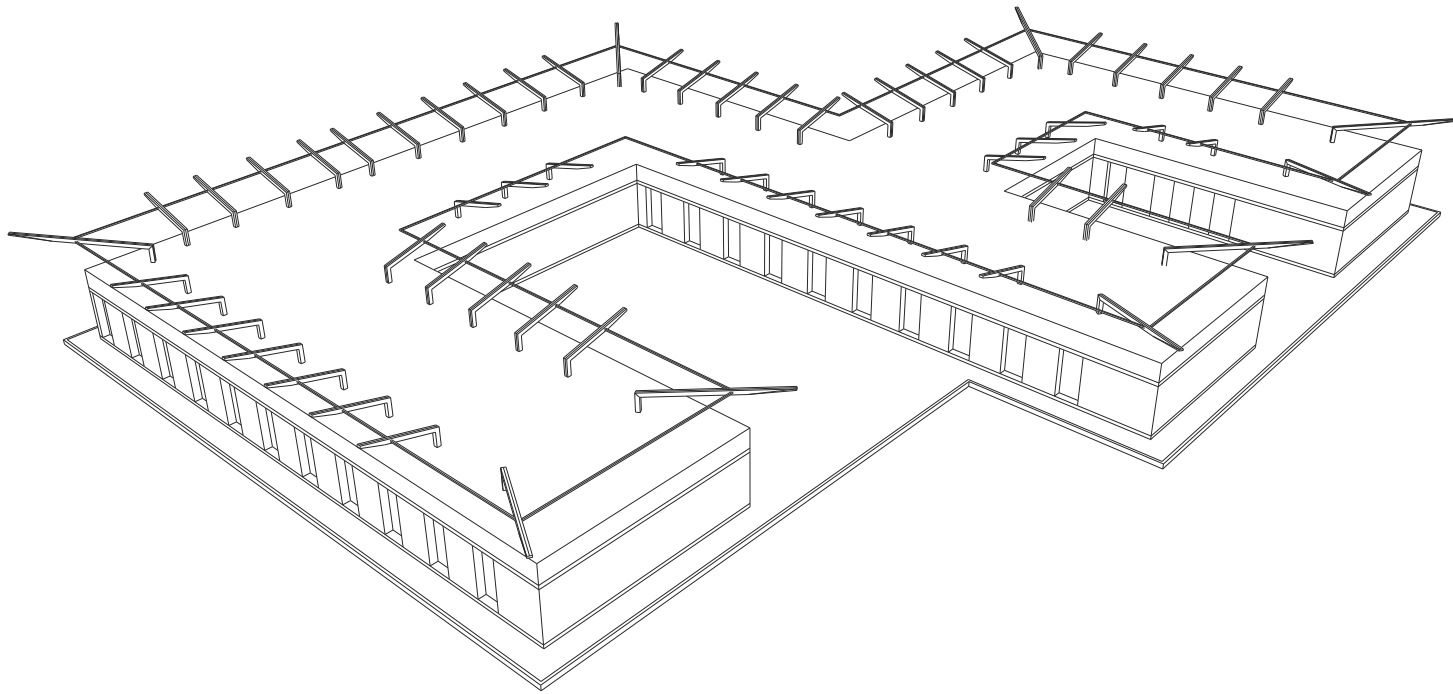

## Rainwater harvesting - Roof design

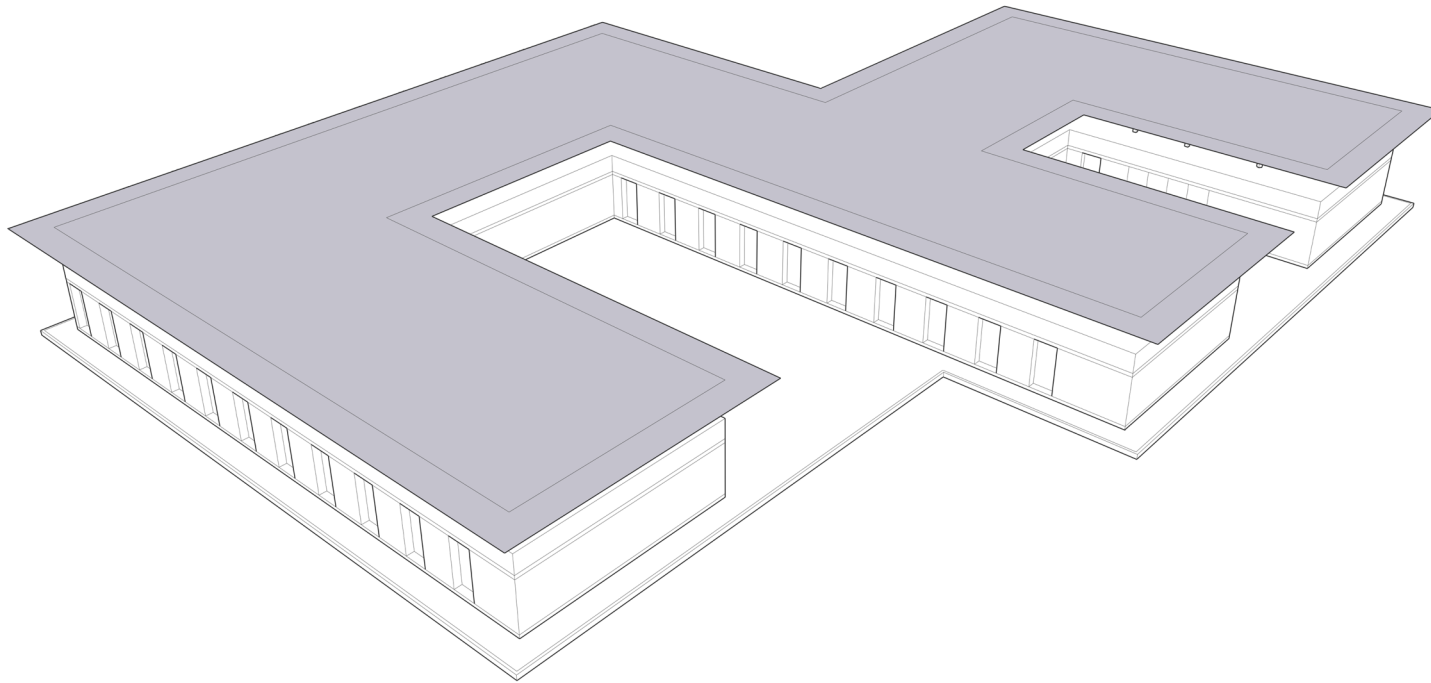

## Rainwater harvesting - Roof design

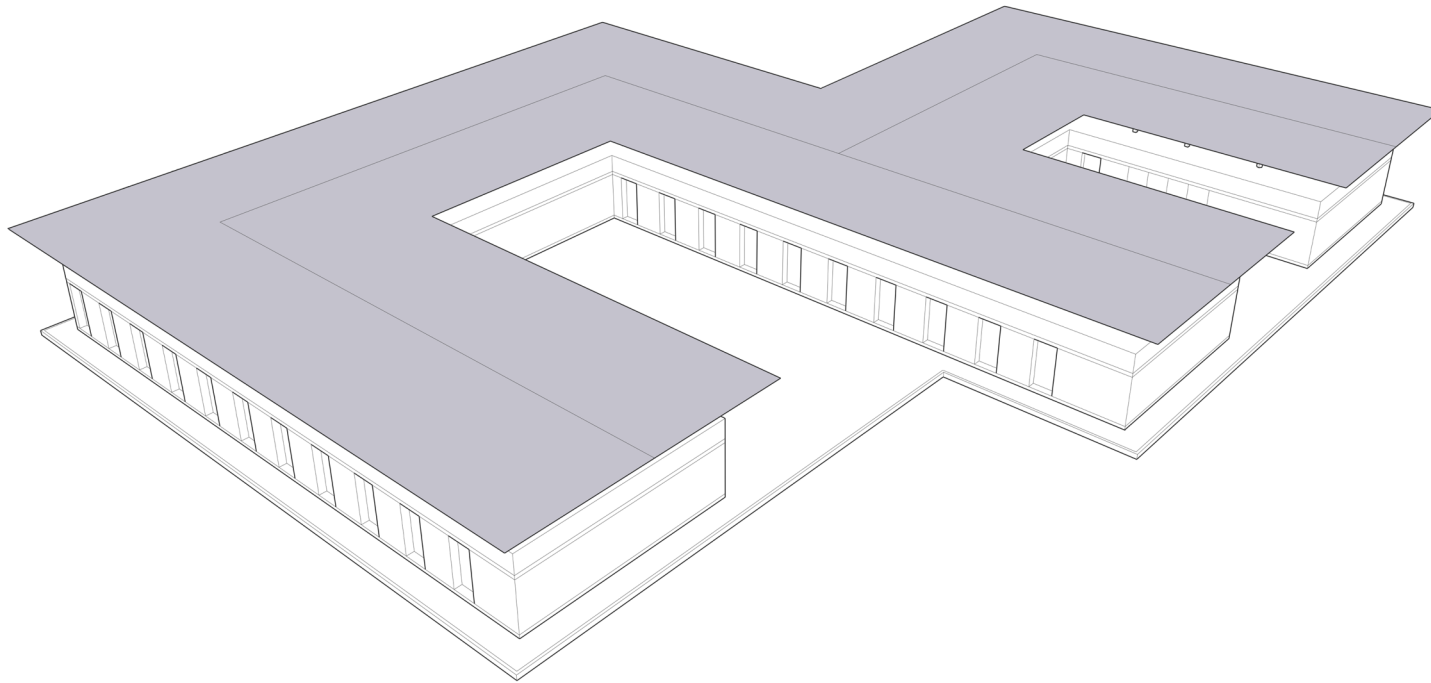

## Rainwater harvesting - Roof design

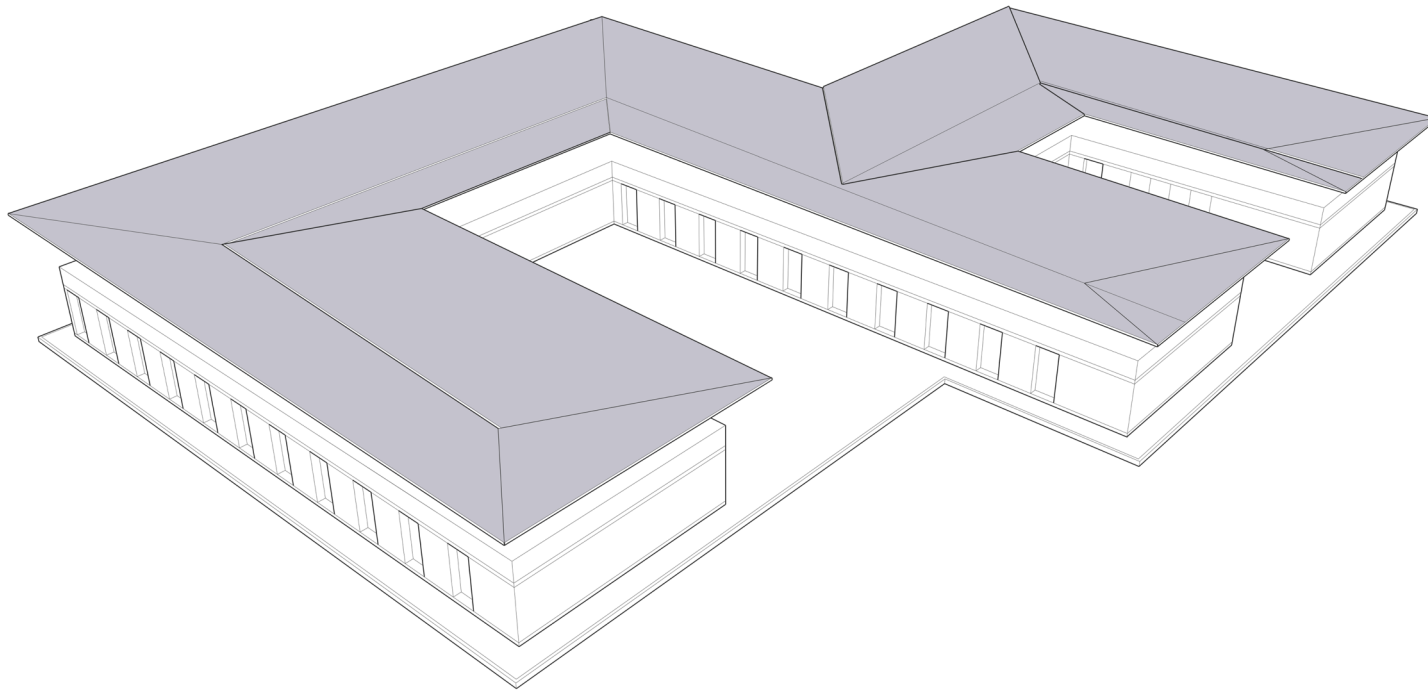





# Membrane bioreactor



## Constructed wetland

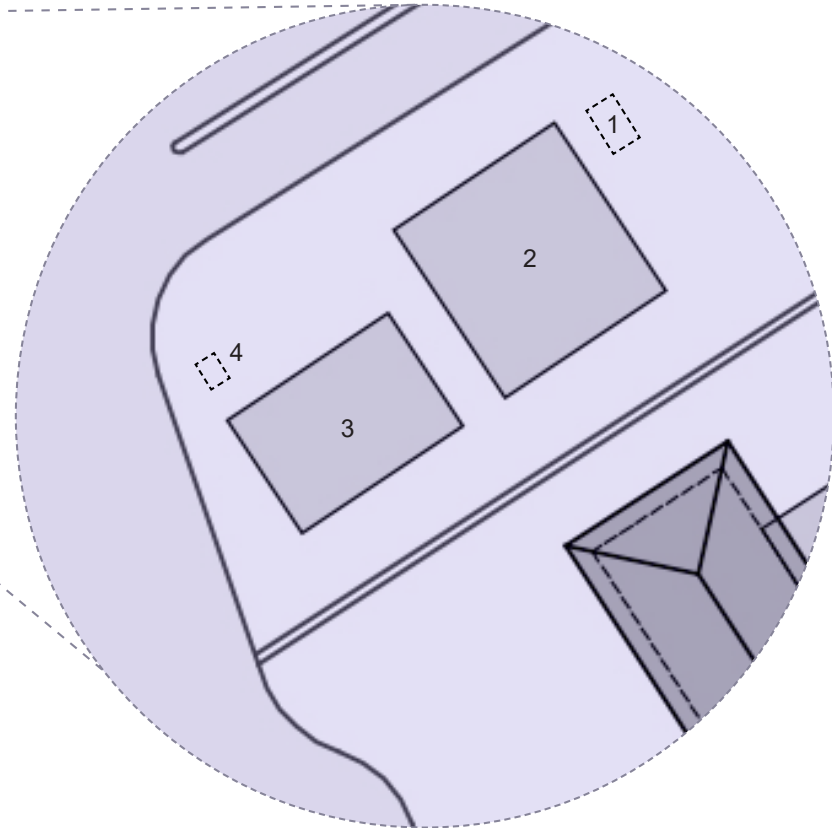

1. Septic tank
2. Horizontal subsurface flow constructed wetland
3. Vertical subsurface flow constructed wetland
4. Storage tank



Promote preservation  
of ecology



Water conservation



Mitigation of damage  
to environment

# Conclusion

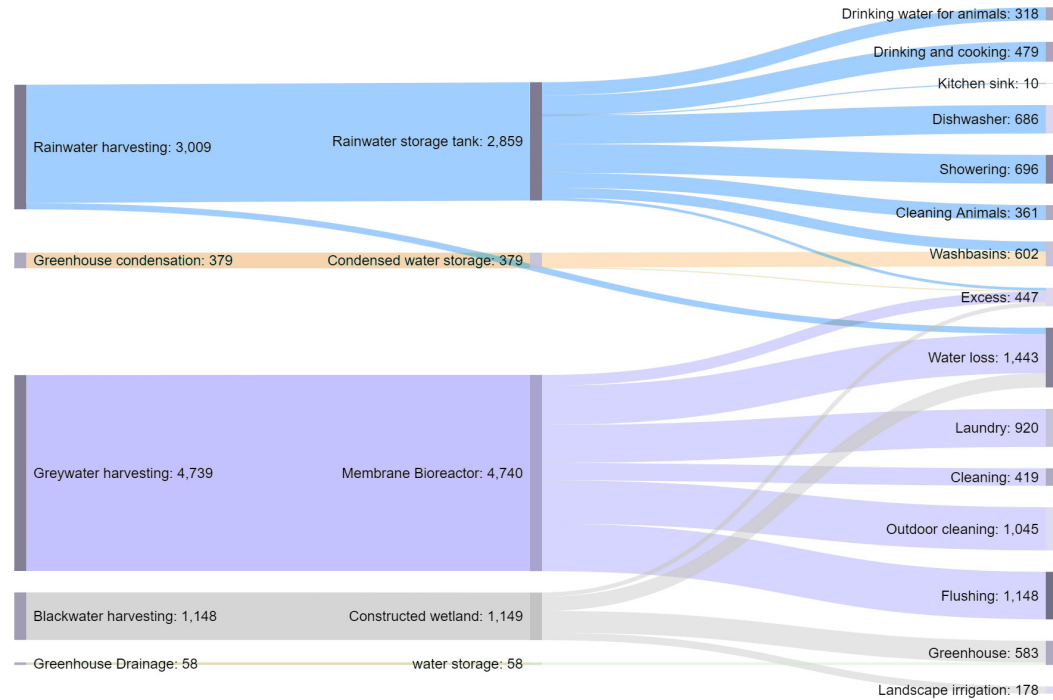

## Sustainable water management scheme



Impact on built form

*The world business council has stated that business cannot survive in a society that thirsts and business is part of the solution and its potential is driven by engagement.*