

MUSIC BUNKER

COMMEMORATIVE PERFORMING ARTS CENTER



INTRODUCTION

BERLIN, HISTORY OF DIVIDED CAPITAL



Introduction

BERLIN - HISTORY



Introduction

BERLIN - HISTORY



Introduction

BERLIN - HISTORY

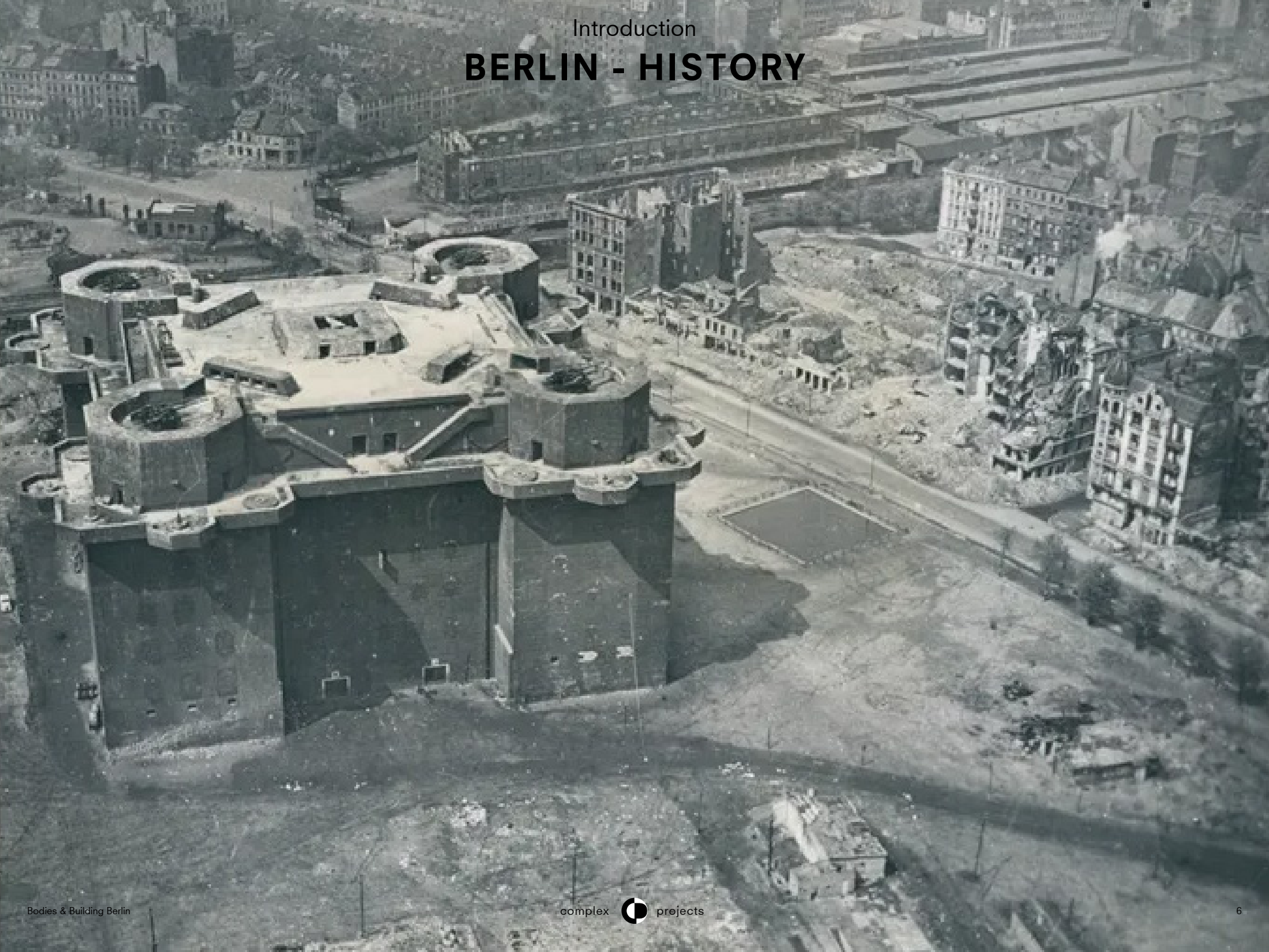

BERLIN - HISTORICAL TRAUMA

Müller-Hegemann noticed that these patients, and dozens of others, had something in common—they all lived close to the Berlin Wall.

In his 1973 book, he gave the syndrome a name: **Mauerkrankheit**, or

Wall Disease.

Annals of Inquiry
Do Walls Change How We Think?
By Jessica Wapner

March 28, 2019

BERLIN - HISTORICAL TRAUMA

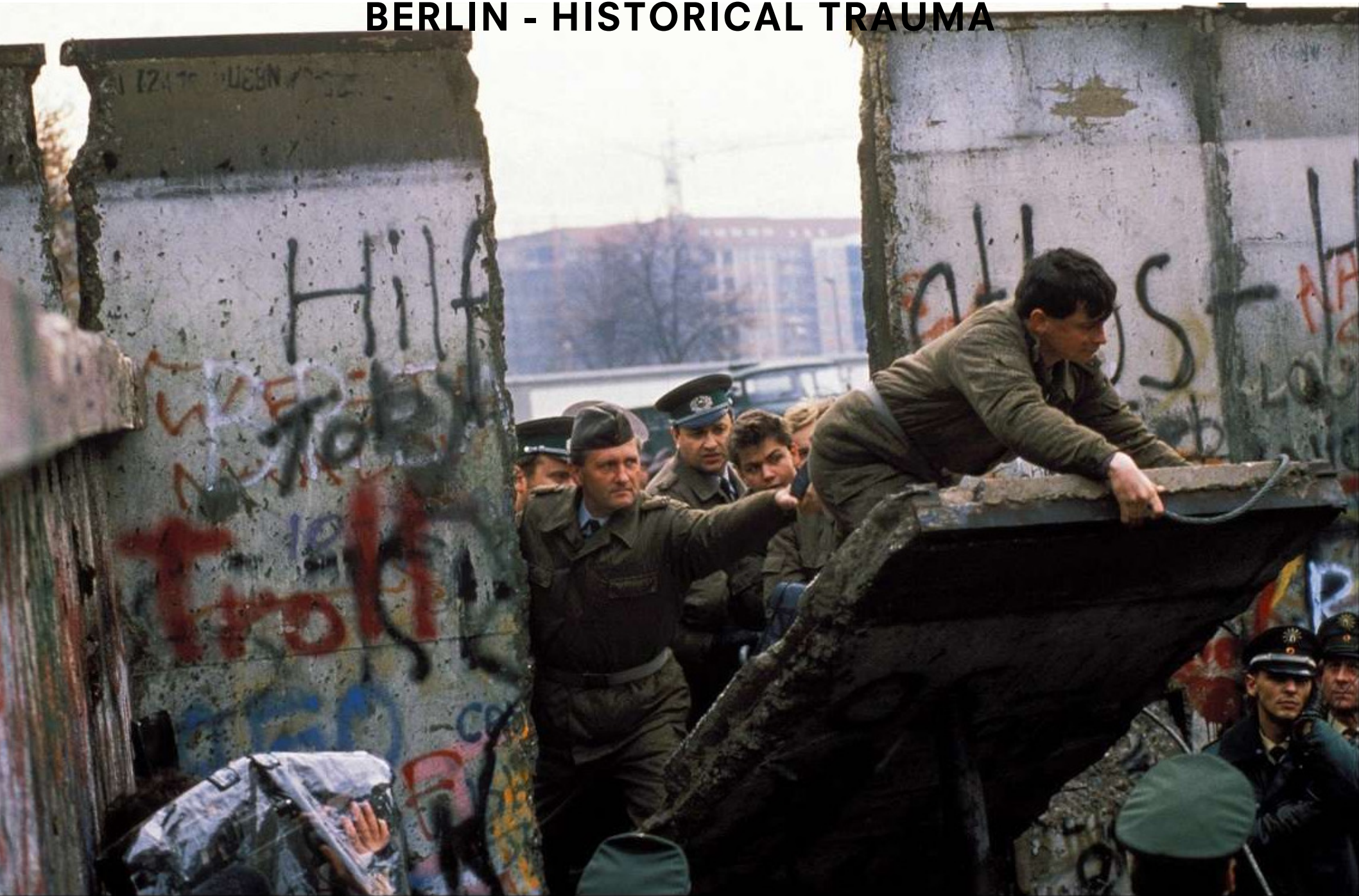

BERLIN - HISTORICAL TRAUMA

In the years after German reunification, psychologists there realized a new syndrome had replaced wall disease: die Mauer in den Köpfen, or
“the wall in the head.”

...According to his study, published in *Psychonomic Bulletin & Review*, in 2005, the participants consistently overestimated the distances between cities that had once been on opposite sides of
the barrier.

Annals of Inquiry
Do Walls Change How We Think?
By Jessica Wapner

March 28, 2019

BEYOND TRAUMA

PERFORMING ARTS
TRAUMA

TRAUMA AND PERFORMING ARTS

Theater/ Performance



Catalyst to re-embodying traumatic experience

Duggan, Patrick Gerald, Who's Who, 2007

TRAUMA AND PERFORMING ARTS

Theater/ Performance



Catalyst to re-embodiment traumatic experience

Duggan, Patrick Gerald, Who's Who, 2007

CULTURAL PARTICIPATION IN GERMANY

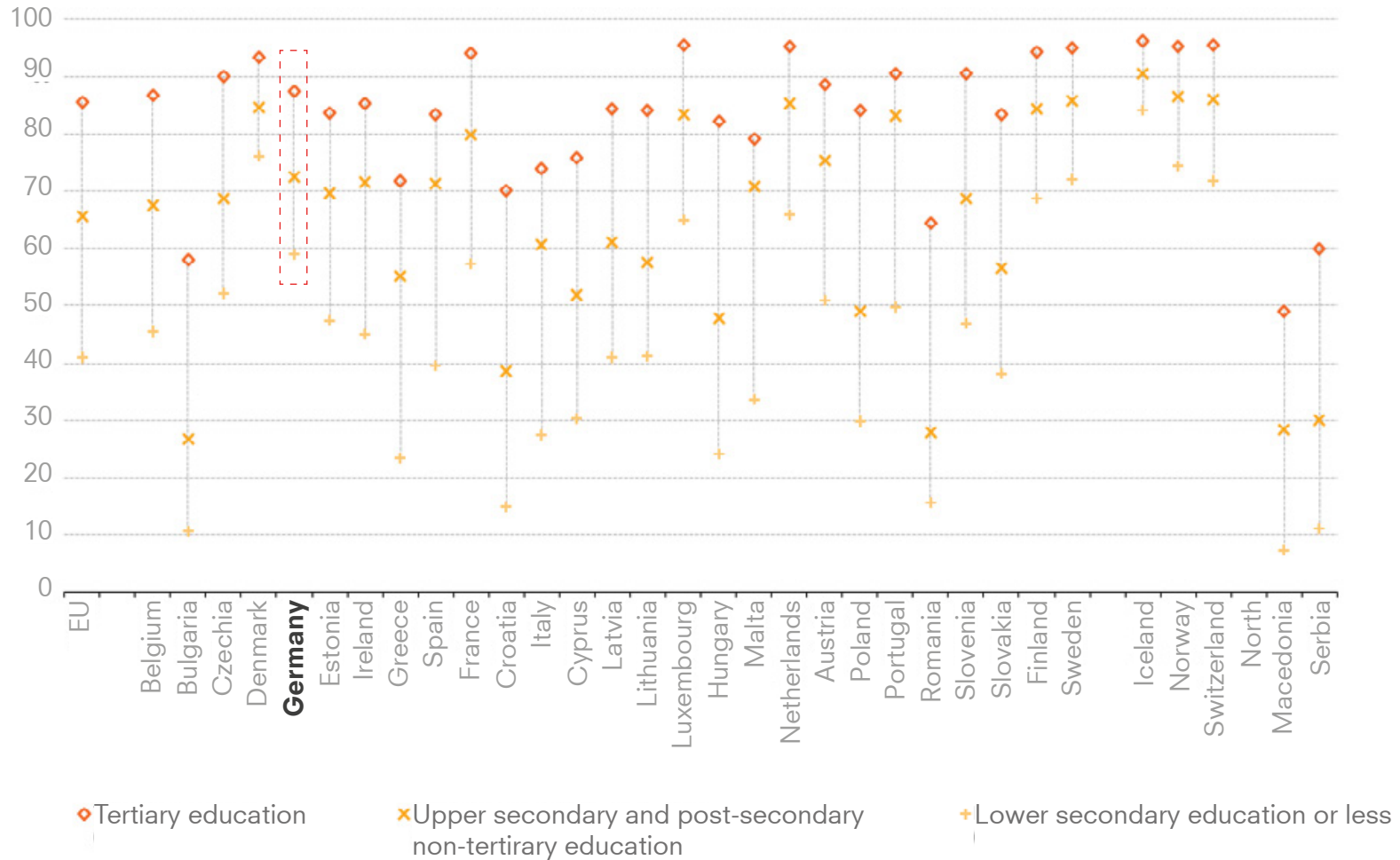

Cultural participation during the previous 12 months
by a low level of education attainment, 2015

CULTURAL PARTICIPATION IN GERMANY

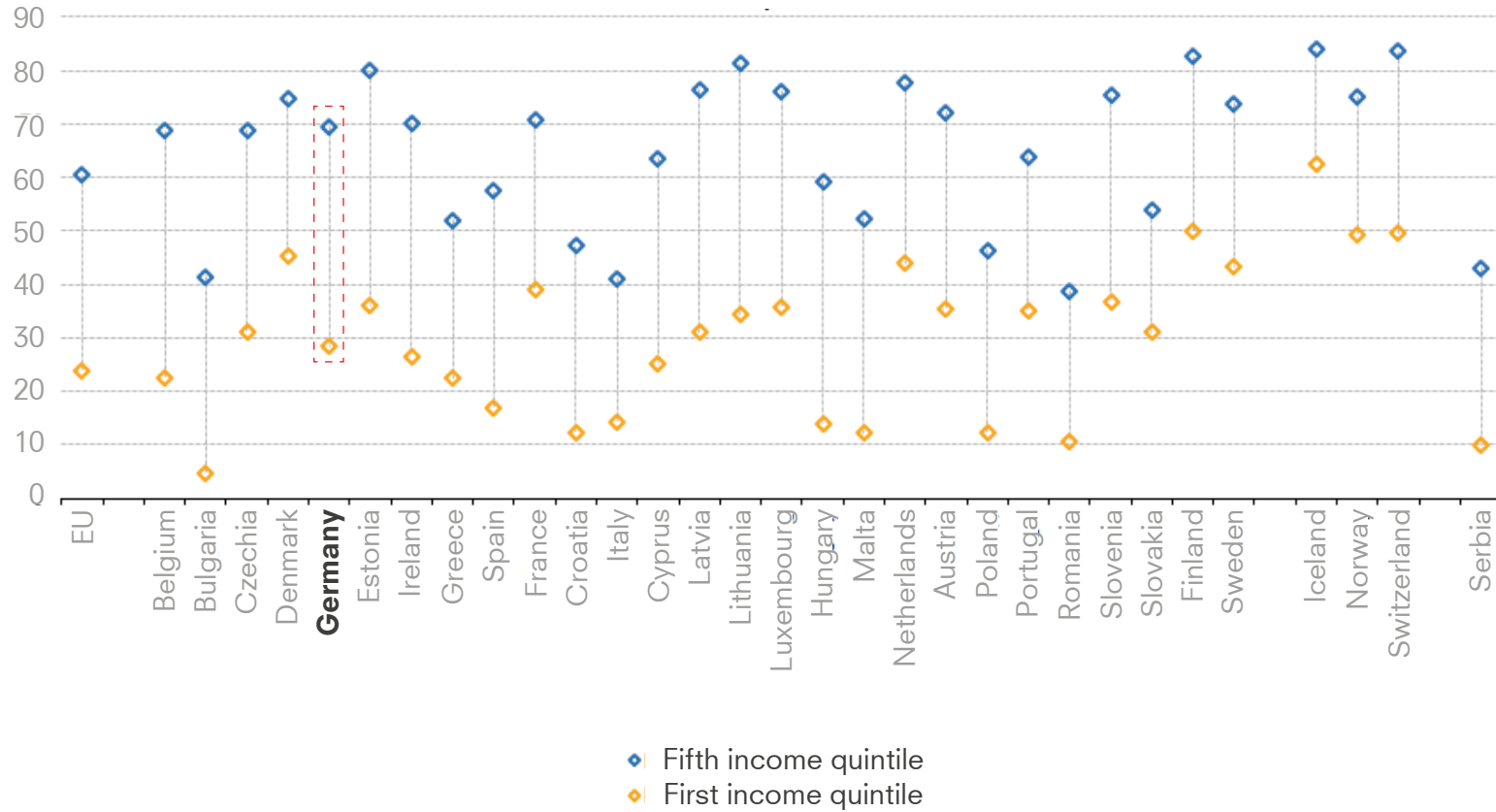

Cultural participation of live performances during the previous 12 months, by income quintile, 2015

CULTURAL PARTICIPATION IN GERMANY

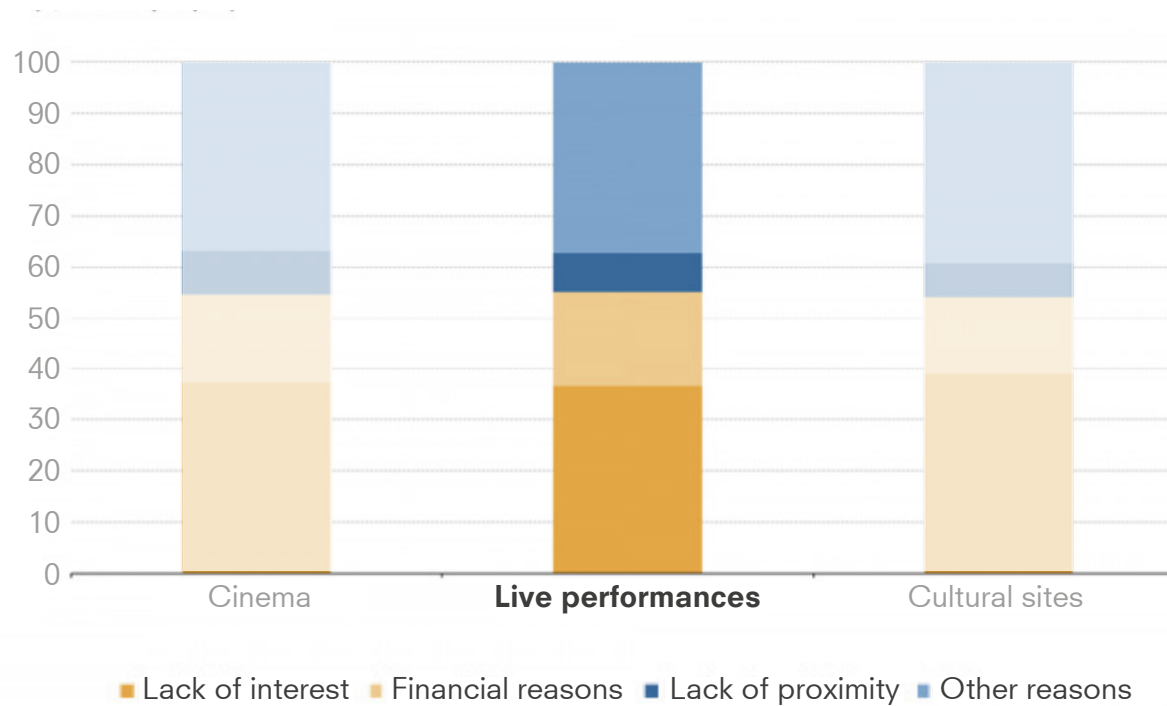

Main reasons for not participating in cultural activities during the previous 12 months, EU, 2015



Over-Sized Ostentatious Performing Arts Center?



Over-Sized Ostentatious Performing Arts Center?

Performing Arts Center Next Generation

Localized & Site specific

Interact in one's life

Performing Arts Center Next Generation

BUILDING

Local Berlin Site specific

BERLIN

interest in urban life

BODY

What if?

Could a contemporary performing arts center
in a historical remnants site heal the **wound of history?**

RESEARCH QUESTION

How can a **bunker**, a historical remnant of World War II, be reused and turned into a **performing arts venue** to heal Berlin's historical wounds?

ADAPTIVE REUSE STRATEGY

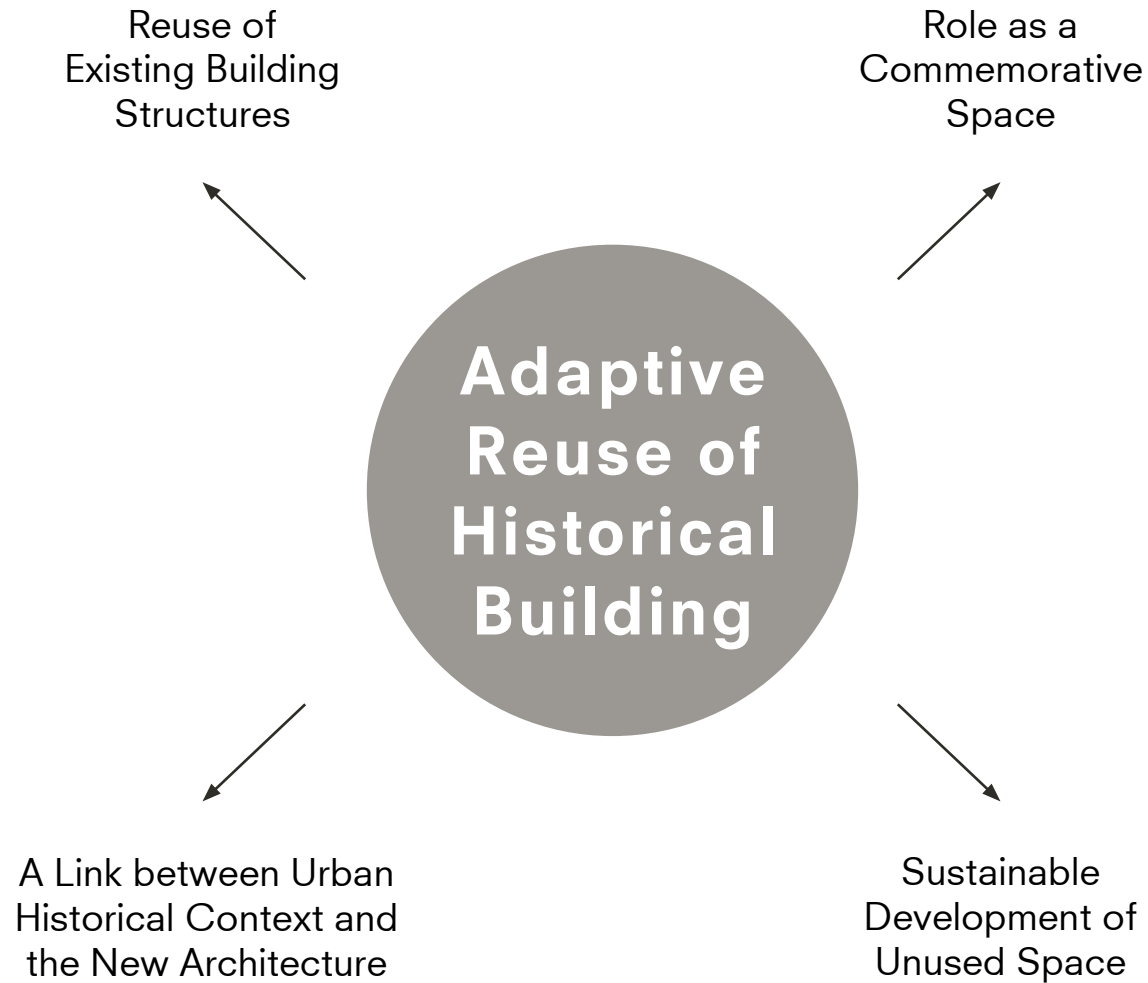

RESEARCH

AUDIENCE - PERFORMER ARRANGEMENTS

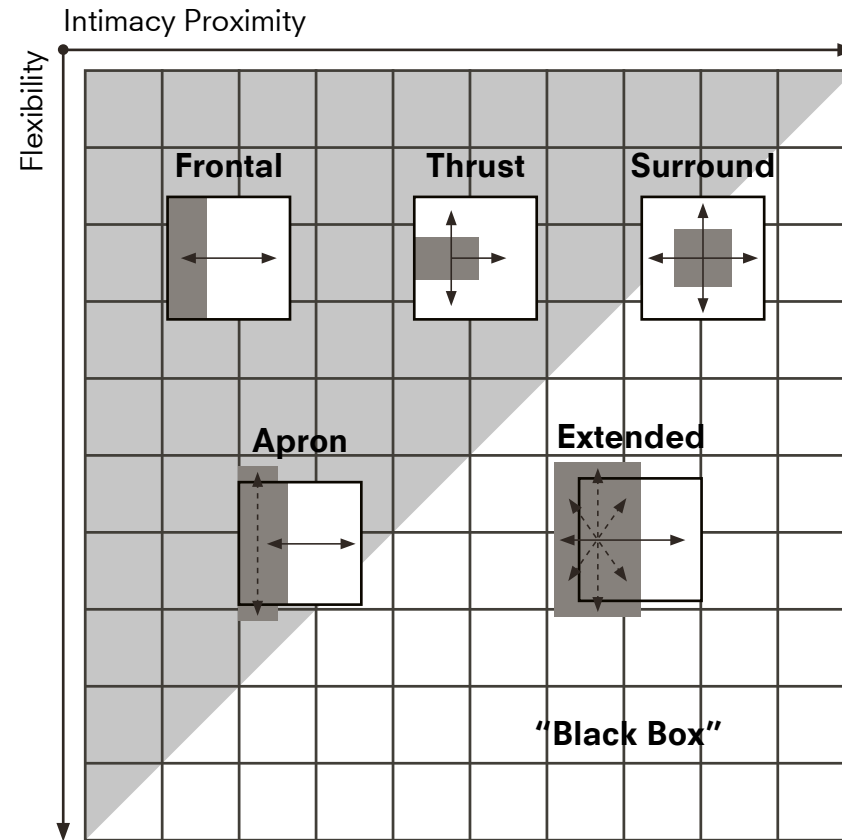

© J.Paul Guyer 2014

AUDIENCE - PERFORMER ARRANGEMENTS

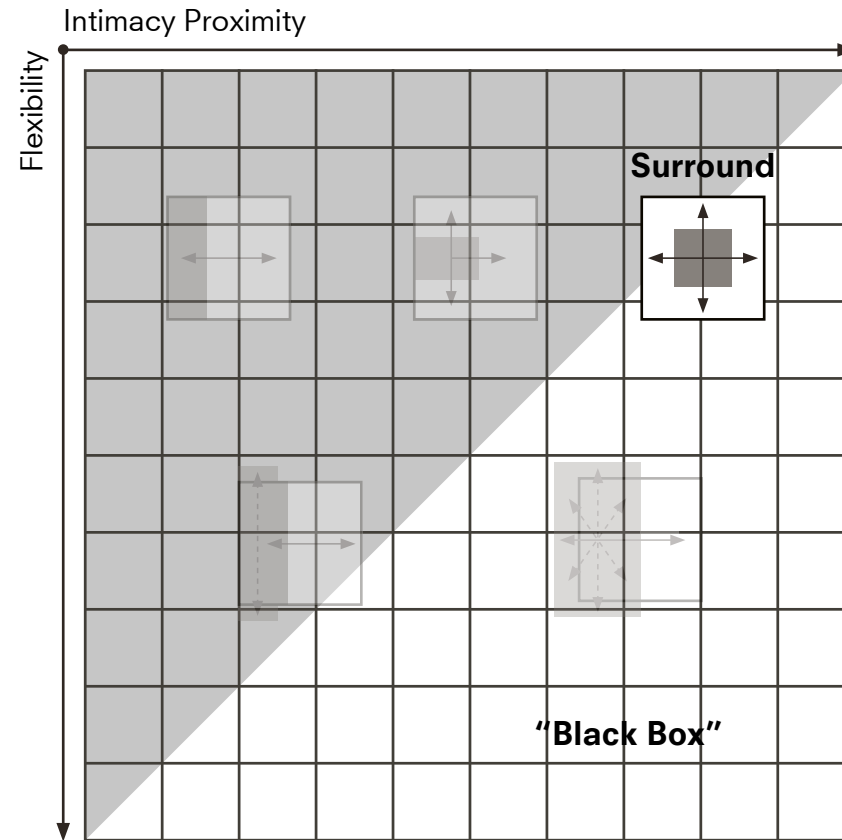

© J.Paul Guyer 2014

REVIVAL OF CLASSICAL CONCERTS IN GERMANY



attendance of 18.2 million
40% more than the football Bundesliga



More concertgoers
aged 20-29 than aged 50-5

Statistics by Deutsche Orchester-Vereinigung DOV, 2017

MODERN TO CONTEMPORARY THEATER TYPES

(Neo) Baroque

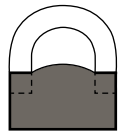

Theater of the restoration

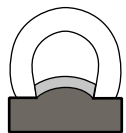

Horseshoe-shaped auditorium
Proscenium stage

Contemporary

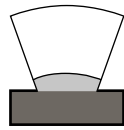

Fan-shaped auditorium
Proscenium stage



Thrust stage

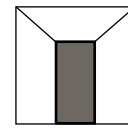

Thrust stage

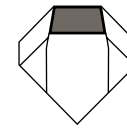

Chambre music
theatre

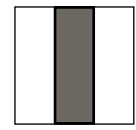

Traverse stage

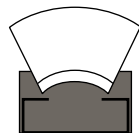

Fan-shaped auditorium
Proscenium, apron,
caliper stage

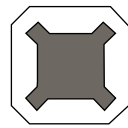

In-the-round stage

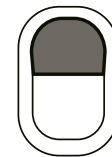

Shoebox hall

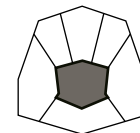

Vineyard concert hall

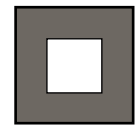

Promenade theatre

MODERN TO CONTEMPORARY THEATER TYPES

(Neo) Baroque

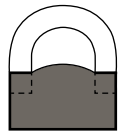

Theater of the restoration

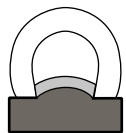

Horseshoe-shaped auditorium
Proscenium stage

Contemporary

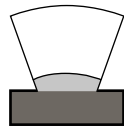

Fan-shaped auditorium
Proscenium stage



Thrust stage

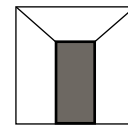

Thrust stage

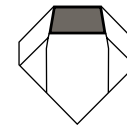

Chambre music
theatre

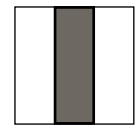

Traverse stage

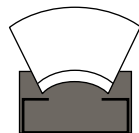

Fan-shaped auditorium
Proscenium, apron,
caliper stage

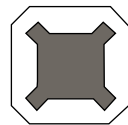

In-the-round stage



Shoebox hall

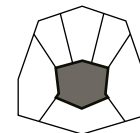

Vineyard concert hall

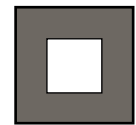

Promenade theatre

Research

THEATER TYPES



Vineyard Style Concert Hall
Classical Concerts



Black Box Theater
Experimental Performing arts

SPATIAL SEQUENCE

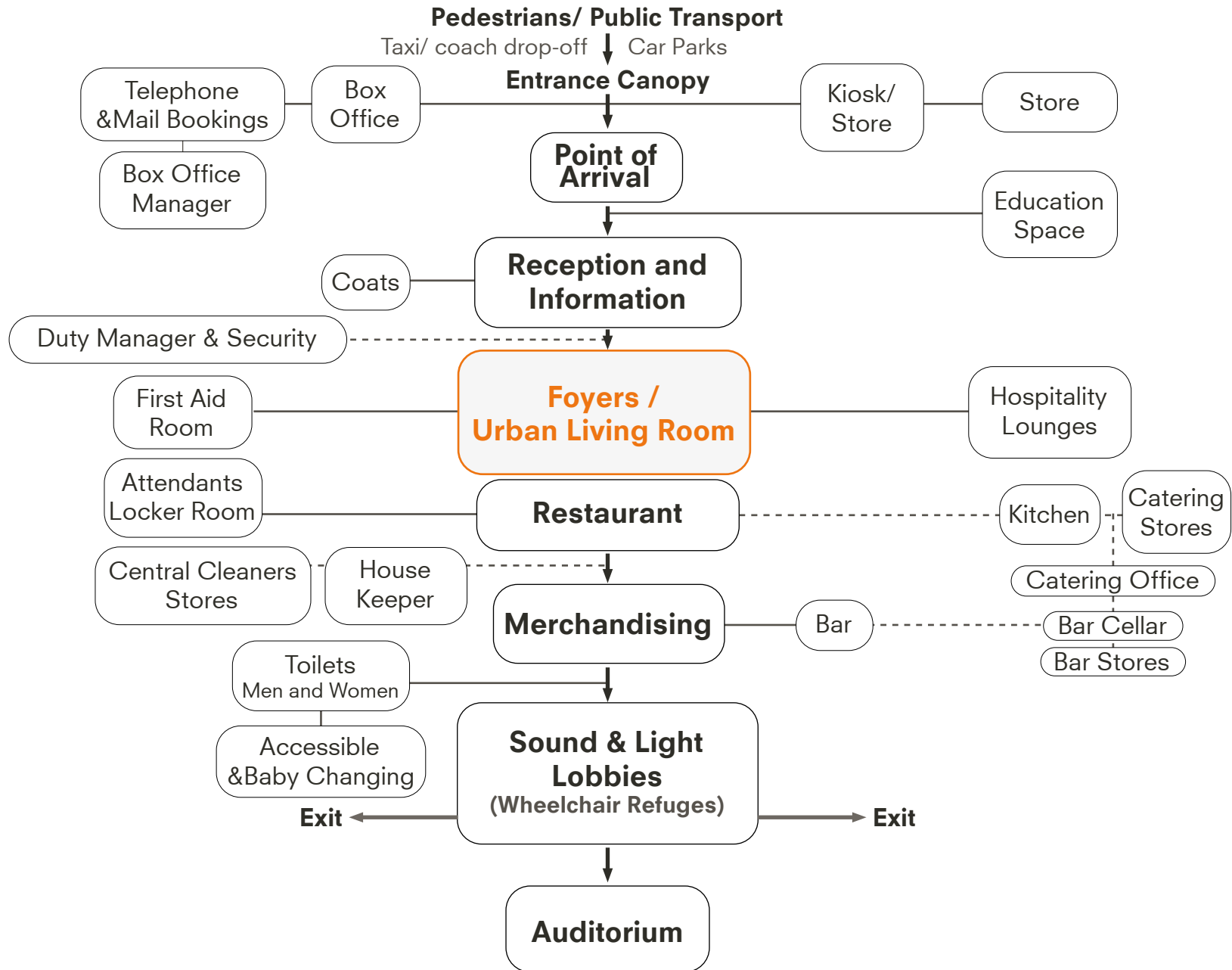

DESIGN BRIEF

PROGRAM

Program

CASE STUDY

01 The Past



Theatre of Epidauros
Greece, late 4th century BC



Teatro Olimpico
Vicenza, 1585



Teatro alla Scala
Milano, 1778



Opera Garnier
Paris, 1875



Royal Albert Hall
London, 1871



Berliner Philharmonie
Berlin, 1963

02 The Present



Lincoln Center
New York, 1969



Oslo Opera House
Oslo, 2007



Margot and Bill Winspear Opera House
Texas, 2008



Dee and Charles Wylie Theatre
Texas, 2009



New World Center
Florida, 2011



Casa da Música
Porto, 2011

03 The Future



Elbphilharmonie
hamburg, 2017



Taipei Performing Arts Center
Taipei, 2014



Taichung Metropolitan Opera House
Taichung, 2014



National Kaohsiung Center for the Arts
Kaohsiung, 2017



Dalian International Conference Center
Dalian, 2012



Harbin Opera House
Harbin, 2015

Program

CASE STUDY

01 The Past



Theatre of Epidauros
Greece, late 4th century BC



Teatro Olimpico
Vicenza, 1585



Teatro alla Scala
Milano, 1778



Opera Garnier
Paris, 1875



Royal Albert Hall
London, 1871



Berliner Philharmonie
Berlin, 1963

02 The Present



Lincoln Center
New York, 1969



Oslo Opera House
Oslo, 2007



Margot and Bill Winspear Opera House
Texas, 2008



Dee and Charles Wylie Theatre
Texas, 2009



New World Center
Florida, 2011



Casa da Música
Porto, 2011

03 The Future



Elbphilharmonie
hamburg, 2017



Taipei Performing Arts Center
Taipei, 2014



Taichung Metropolitan Opera House
Taichung, 2014



National Kaohsiung Center for the Arts
Kaohsiung, 2017

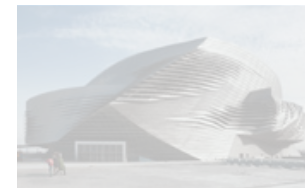

Dalian International Conference Center
Dalian, 2012



Harbin Opera House
Harbin, 2015

Program

CASE STUDY

Elbphilharmonie



National Kaohsiung Center for the Arts



Oslo Opera House

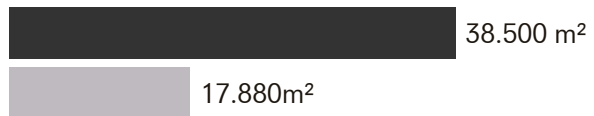

Taipei Performing Arts Center



Casa da Música

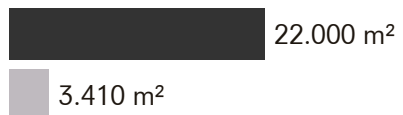

■ Gross floor area
■ Building footprint

Program

CASE STUDY

Elbphilharmonie

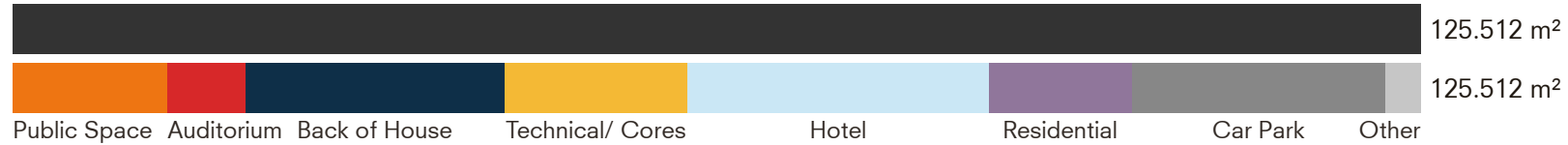

National Kaohsiung Center for the Arts



Oslo Opera House



Taipei Performing Arts Center



Casa da Música



Program

PROGRAM BREAKDOWN

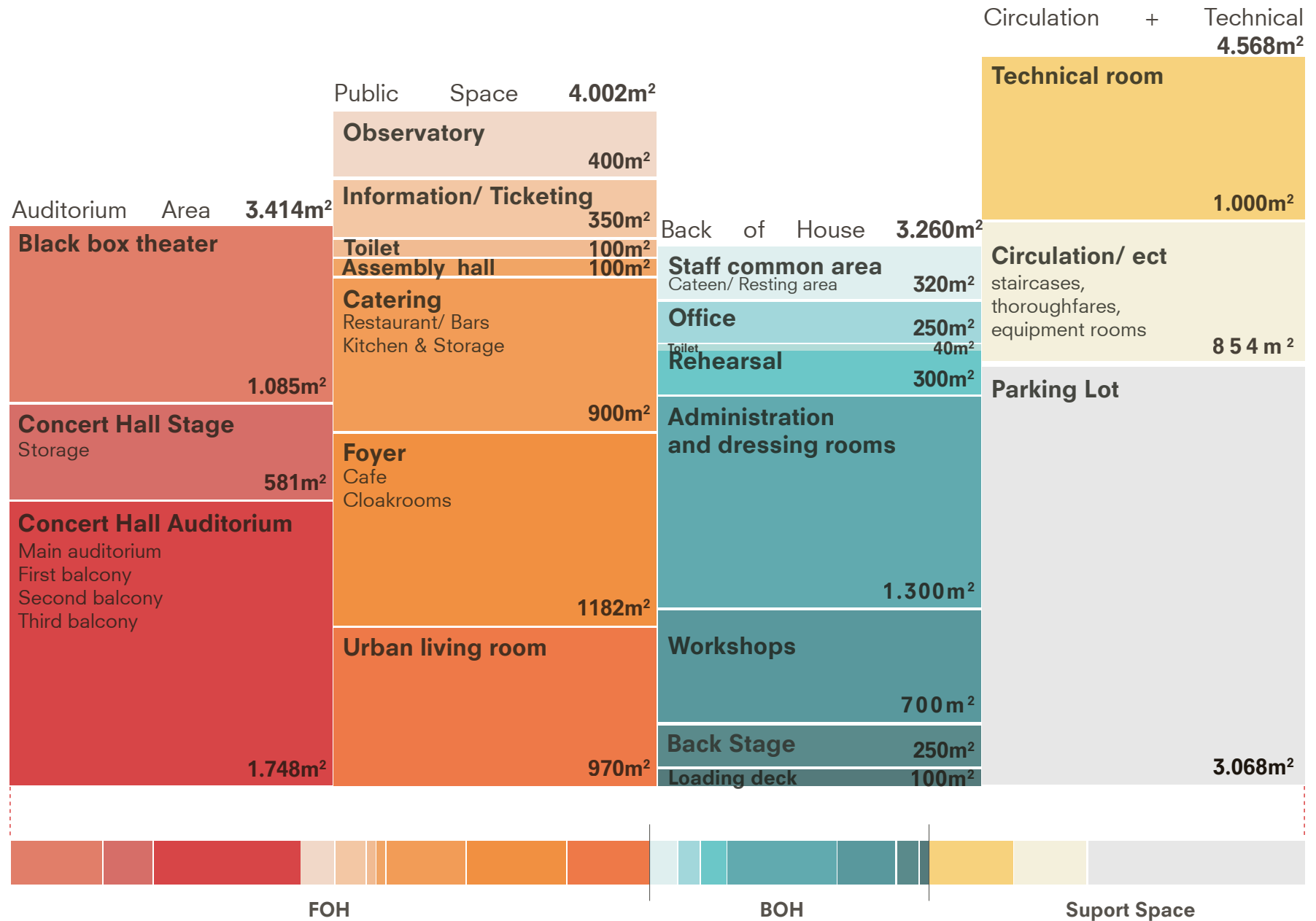

SPATIAL RELATION DIAGRAM

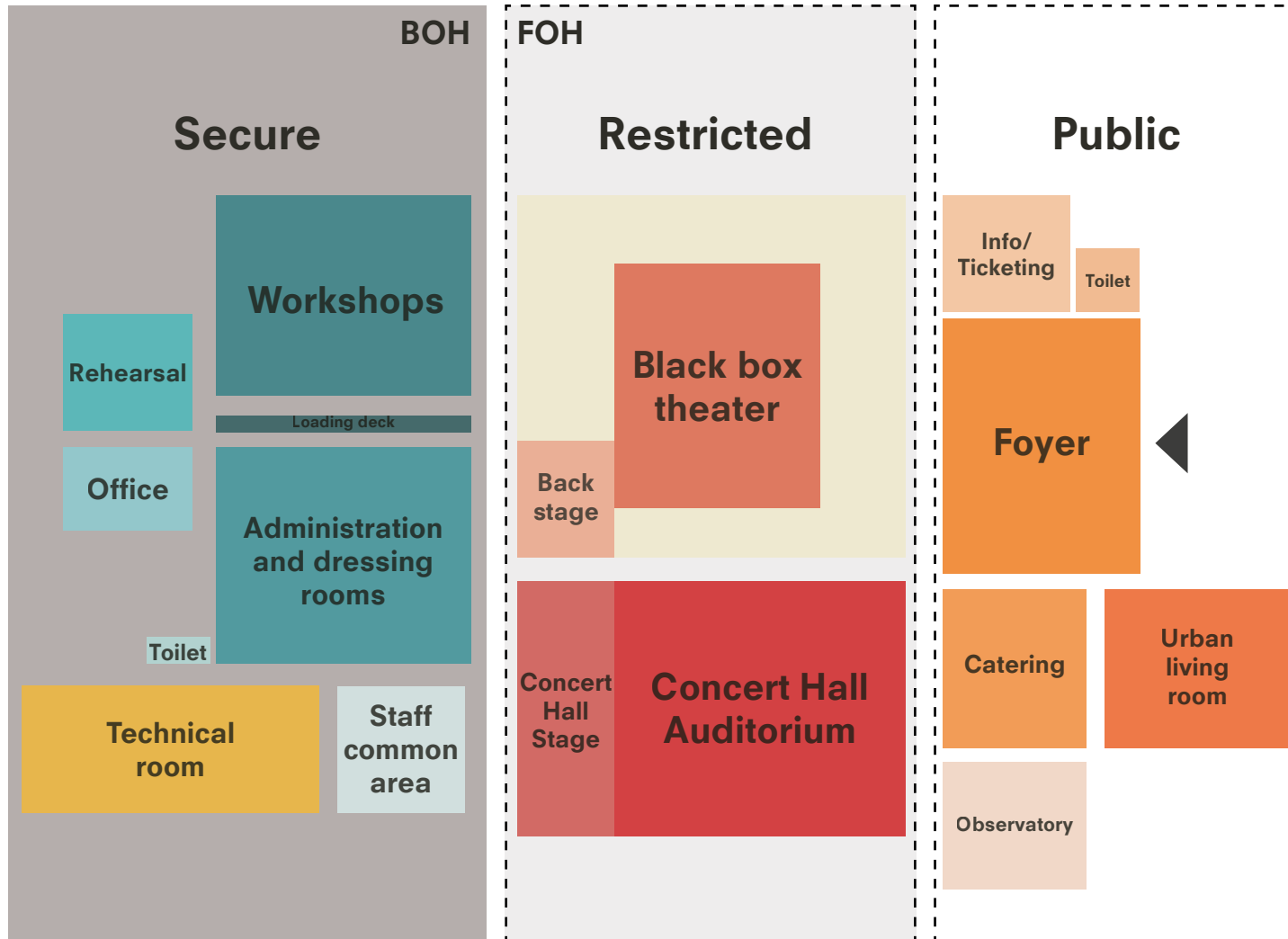

SITE

Site SITE SELECTION

01 THE TWIN BUNKERS



02 SCHONHOLZER HEIDE BUNKERS



03 GESUNDBRUNNEN BUNKER

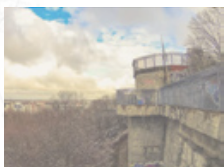

04 BOROS COLLECTION BUNKER



05 DER KEGEL

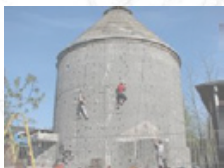

06 BERLIN STORY BUNKER



07 HOCHBUNKER PALLASSTRASSE



08 FICHTE BUNKER

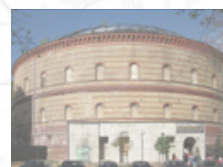

09 TEMPELHOF BUNKER



10 HOCHBUNKER EISWALDTSTRASSE



Site SITE SELECTION

01 THE TWIN BUNKERS
1940, World war II bunker, **Car repair shop**



02 SCHONHOLZER HEIDE BUNKERS
Before 1940, Air raids shelter



03 GESUNDBRUNNEN BUNKER
1944, Civilian bomb shelter

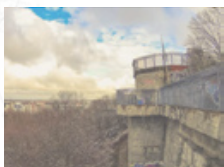

04 BOROS COLLECTION BUNKER
1943, Air-raid shelter, **Art gallery and private apartment**

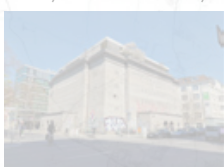

05 DER KEGEL
Around 1940, Air-raid shelter, **Rock Climbing gym**

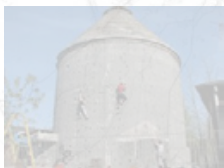

06 BERLIN STORY BUNKER
1942, World war II air raids shelter, **Museum**



07 HOCHBUNKER PALLASSTRASSE
1945, Air raids shelter



08 FICHTE BUNKER
1884, Gasometer/ Air raid shelter

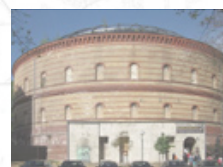

09 TEMPELHOF BUNKER
Around 1940, Air raid shelter



10 HOCHBUNKER EISWALDTSTRASSE
Around 1940, Air raid shelter

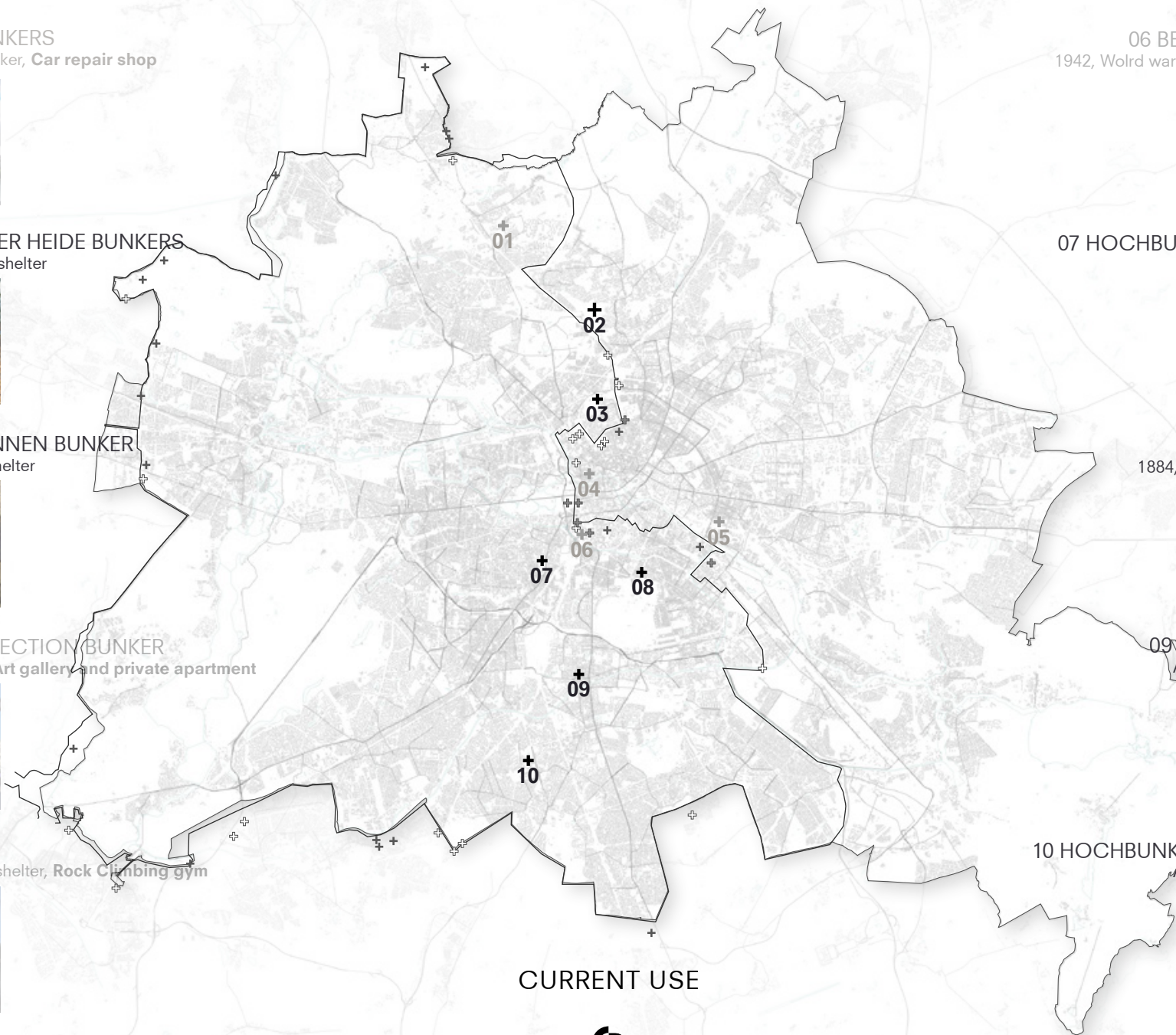

CURRENT USE

Site SITE SELECTION

01 THE TWIN BUNKERS

1940, World War II bunker, Car repair shop



02 SCHONHOLZER HEIDE BUNKERS

Before 1940, Air raids shelter



03 GESUNDBRUNNEN BUNKER

1944, Civilian bomb shelter



04 BOROS COLLECTION BUNKER

1943, Air-raid shelter, Art gallery and private apartment



05 DER KEGEL

Around 1940, Air-raid shelter, Rock Climbing gym



06 BERLIN STORY BUNKER

1942, Air raids shelter, Museum



07 HOCHBUNKER PALLASSTRASSE

1945, Air raids shelter



08 FICHTE BUNKER

1884, Gasometer/ Air raid shelter



09 TEMPELHOF BUNKER

Around 1940, Air raid shelter



10 HOCHBUNKER EISWALDTSTRASSE

Around 1940, Air raid shelter

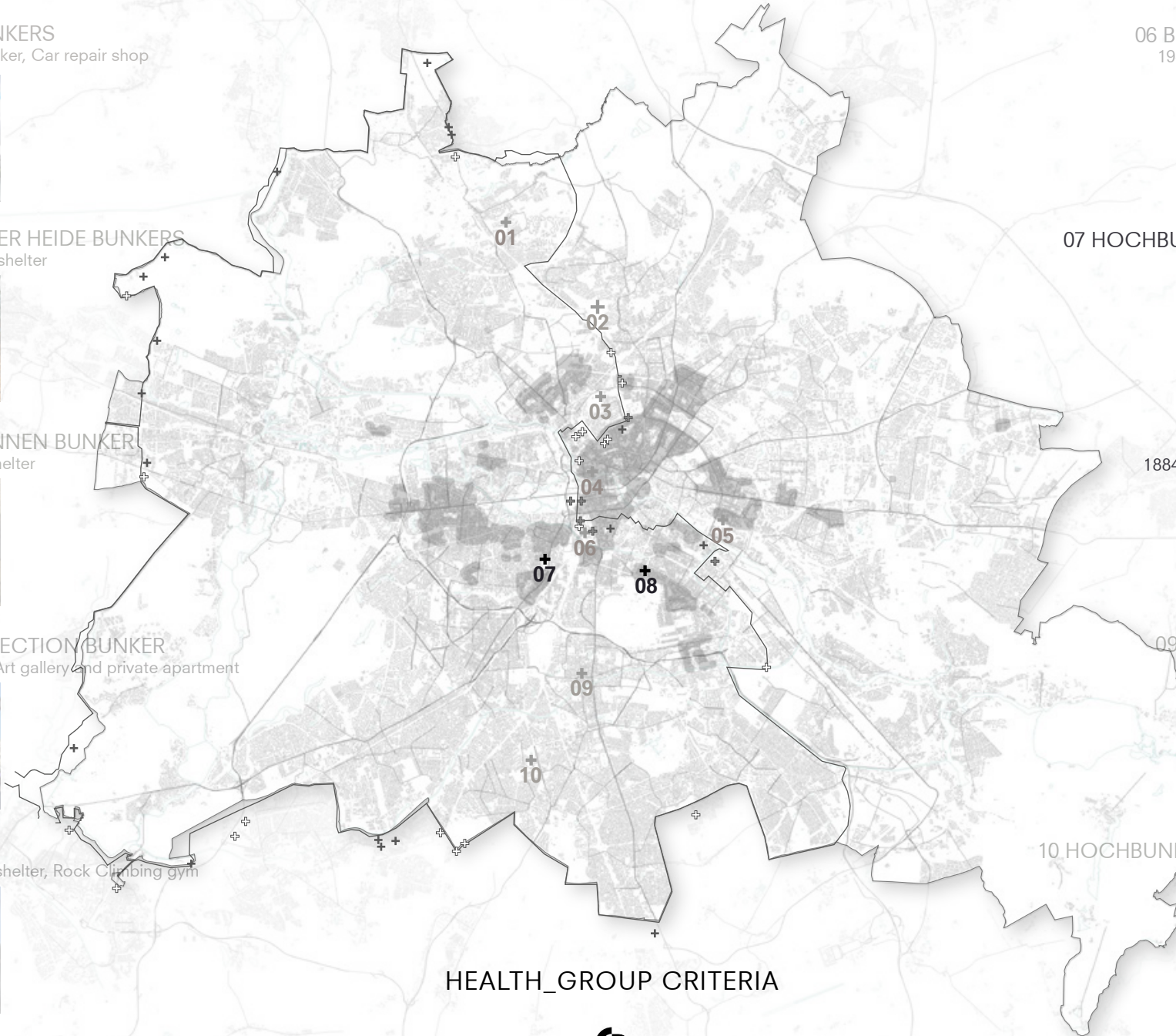

HEALTH_GROUP CRITERIA

Site SITE SELECTION

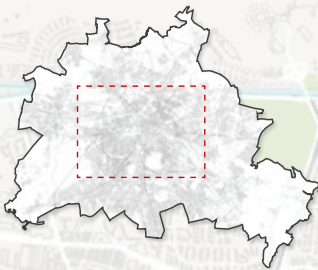

OTHER PERFORMING ARTS SPACE

- a Uferstudios GmbH
- b Max-Schmeling-Halle
- c HALLE TANZBÜHNE BERLIN
- d Lyrik
- e Velodrom
- f Acker Stadt Palast
- g Clärchens Ballhaus
- h Ballet - and dance school TanzZwiEt
- i Sophiensaele
- j Berliner Residenz Konzerte
- k Admiralspalast
- l Haus der Kulturen der Welt
- n Staatsoper Unter den Linden
- m Komische Oper Berlin
- o Pierre Boulez Saal in Berlin
- p Pierre Boulez Saal in Berlin
- q Deutsche Oper Berlin
- r Rundfunk-Sinfonieorchester Berlin
- s Radialsystem
- t Philharmonie Berlin
- u Astra Kulturhaus
- v Haus des Rundfunks
- w Mercedes-Benz Arena
- x HAU Hebbel am Ufer
- y Treptow Arena
- z Neuköllner Oper
- a' Café in the Schwartz Villa
- b' "Connecting You" Dance School
- c' Deutsches Theater Berlin

LEGEND

- BUNKER SITE**
- 07 HOCHBUNKER PALLASSTRABE**
- 08 FICHTE BUNKER**

ADJACENT PERFORMING ARTS SPACE

- A** Speakeazy Stage & Studio
- B** Havana La Discoteca Latina
- C** Tanzfabrik Berlin
- D** Huxleys Neue Welt
- E** Labor Gras
- F** Dance School "Traumtänzer"

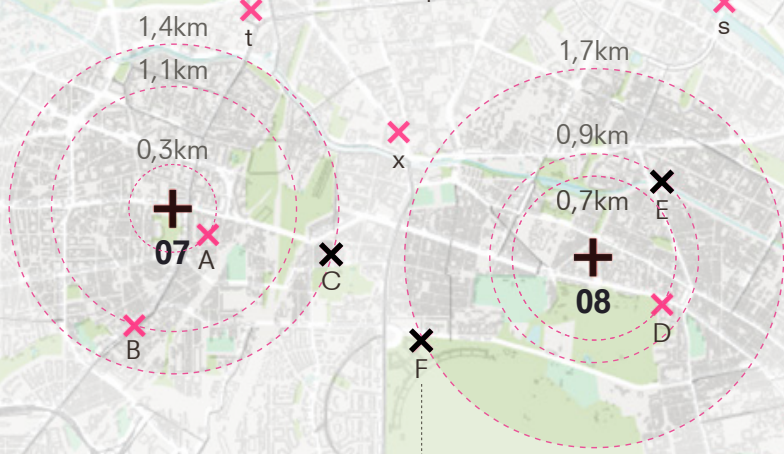

Potential Collaborative Facility

Site

FICHTE BUNKER



Location : Fichtestraße 6, 10967 Berlin

Site
FICHTE BUNKER



Site SITE ANALYSIS

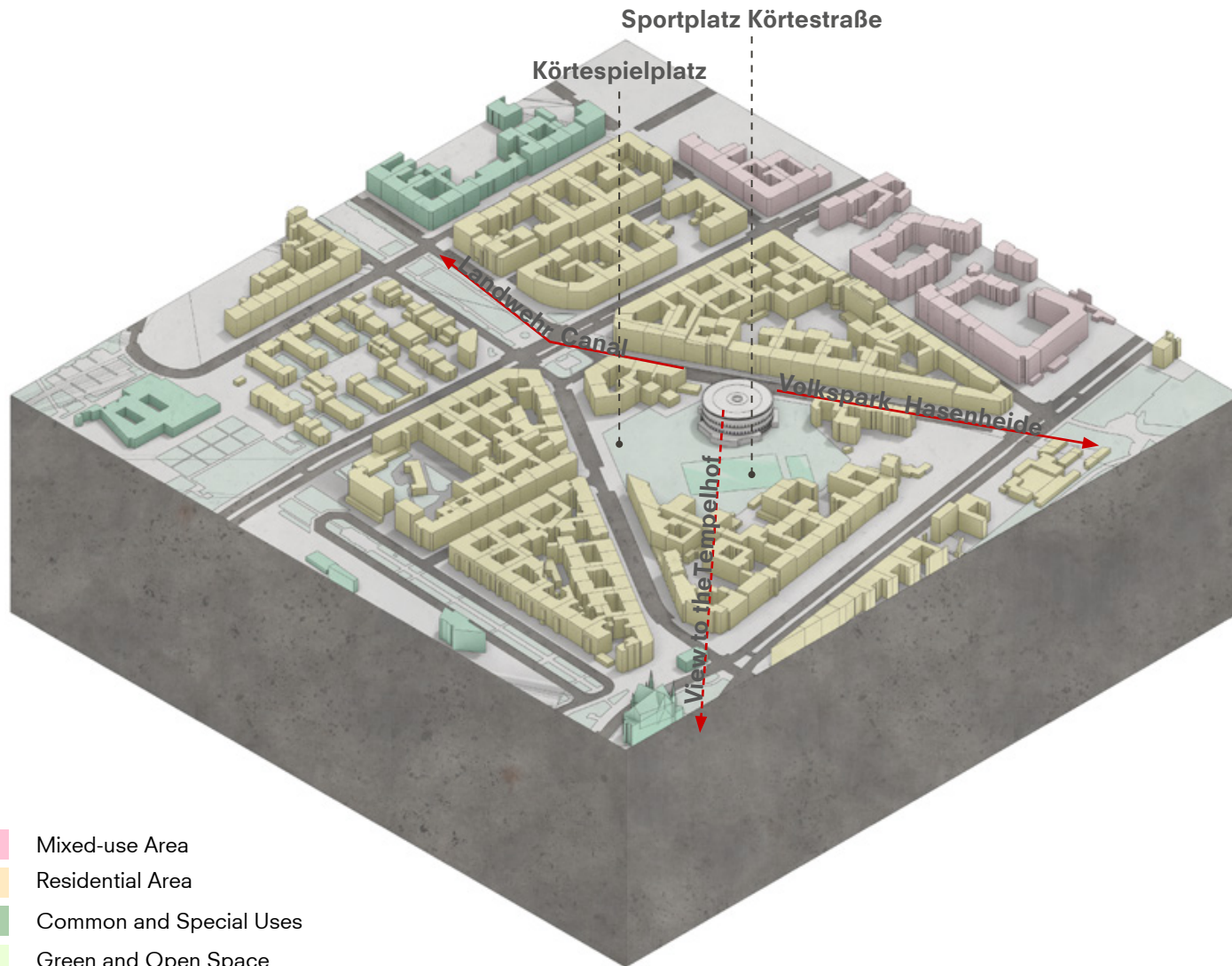

- Mixed-use Area
- Residential Area
- Common and Special Uses
- Green and Open Space

CLIENT

Client

STAKEHOLDERS

Main Stakeholders

Investment decision maker
Federal government commissioner
for culture and media

Senior responsible owner
Senate Department for Culture
and Social Cohesion

Project sponsor
Berliner Philharmoniker

Relevant Stakeholders

Project board

The LAFT Berlin

Local Dacnce Institutes
(Traumtänzer, Labor Gras)

Berlin Underworlds Association

Main Users

Audience

Berliner Philharmoniker

The LAFT Berlin

Artists/ Performers

Locals

Local Dacnce Institutes (Traumtänzer, Labor Gras)

Client

MAIN STAKEHOLDERS

Investment decision maker



Federal government commissioner
for culture and media

Senior responsible owner



Senate Department for
Culture and Social Cohesion

Project sponsor



Berliner Philharmoniker

Client

WHO IS RUNNING THE FITCHTE BUNKER?

"Our primary aim is to explore and document the city's underground architecture and **make it accessible to the public**. We try to conserve historically relevant underground structures and preserve them for future generations."

Berlin Underworlds Association

Client

RELATED STAKEHOLDERS



The LAFT Berlin – State Association of Free Performing Arts Berlin eV – represents the interests of **Berlin's professional independent performing arts artists** towards the public and politics. With the regional association they have created an instrument with which they can effectively support their artistic activities through representation, publicity and services.

LAFT Landesverband freie
Theaterschaffende Berlin e.V.
BERLIN

DESIGN CONCEPT

Design Concept

HISTORY AND FUTURE

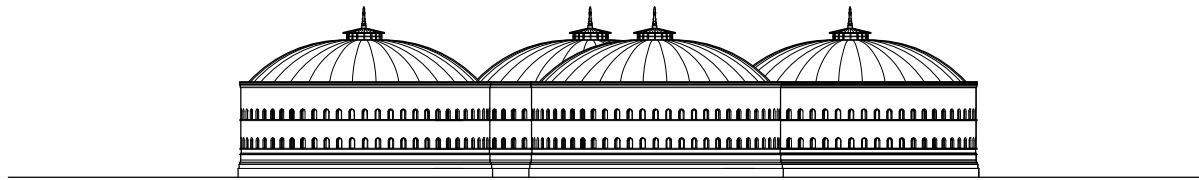

1871 Gas Holder

Design Concept

HISTORY AND FUTURE

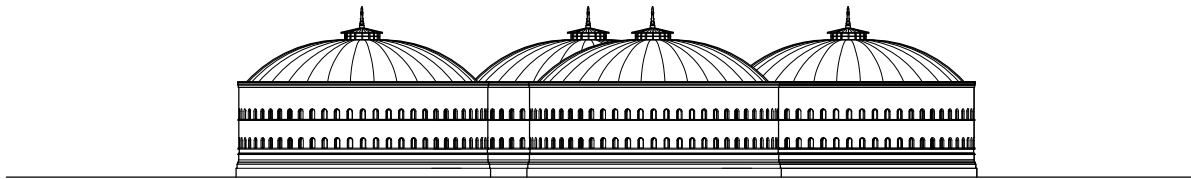

1871 Gas Holder

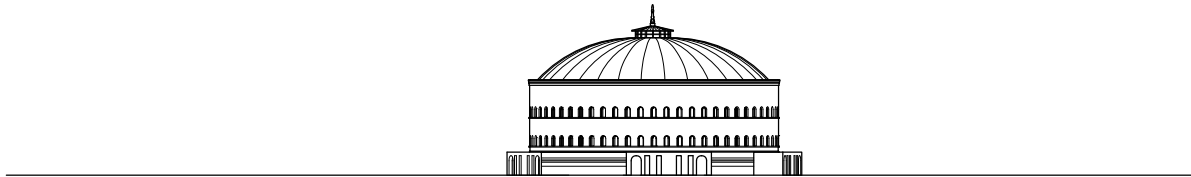

1941 Air-raid Shelter for Women and Children

Design Concept

HISTORY AND FUTURE

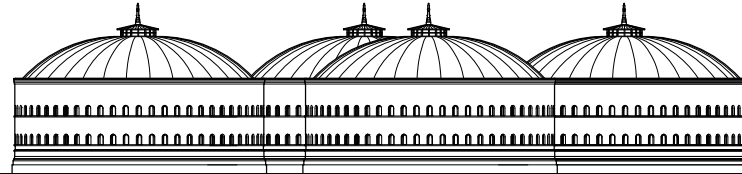

1871 Gas Holder

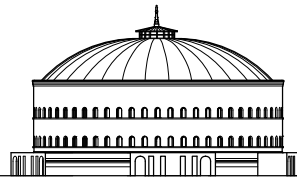

1941 Air-raid Shelter for Women and Children

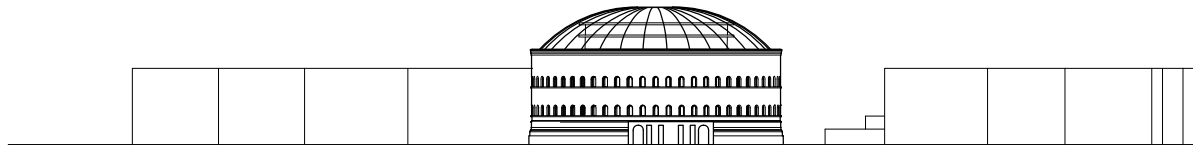

2010 "Circlehouse" of 13 Condominiums on Top of the Bunker

Design Concept
HISTORY AND FUTURE

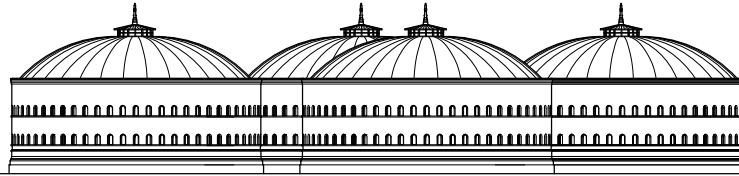

1871 Gas Holder

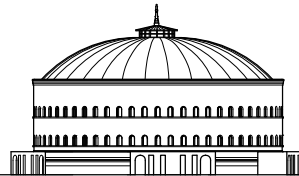

1941 Air-raid Shelter for Women and Children

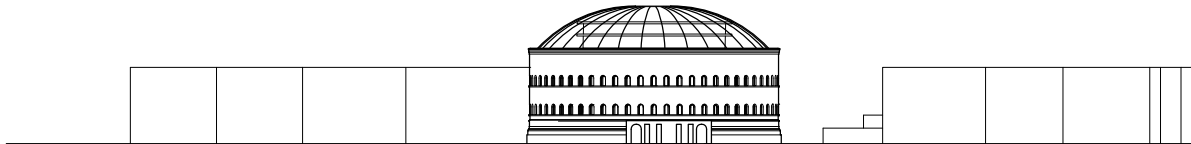

2010 "Circlehouse" of 13 Condominiums on Top of the Bunker

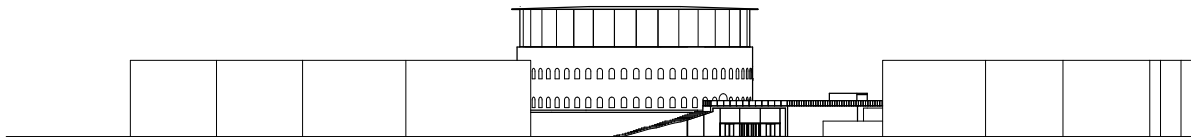

2024 ???

Design Concept

MASSING STUDIES

Program inside the bunker

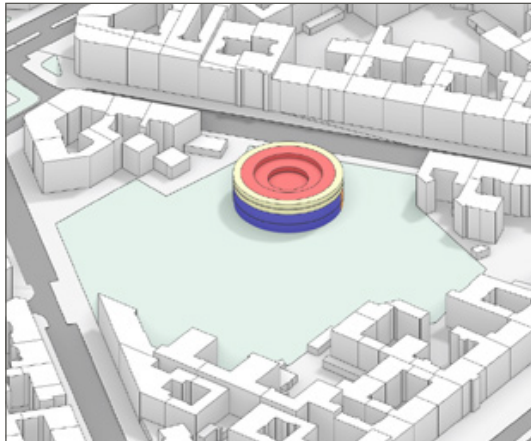

Height : 21m
Building footprint : 2.463m²

Extension Alternative 1 _ Vertical

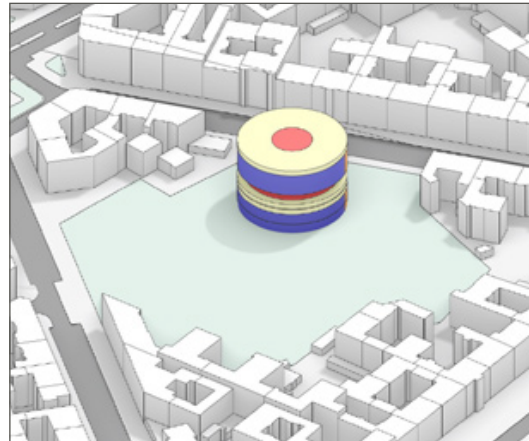

Height : 35m
Building footprint : 2.463m²

Extension Alternative 2 _ Twin

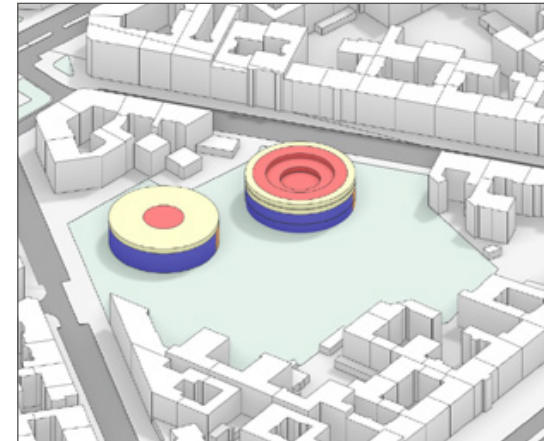

Height : 21m, 14m
Building footprint : 4.926m²

Extension Alternative 3 _ Flat

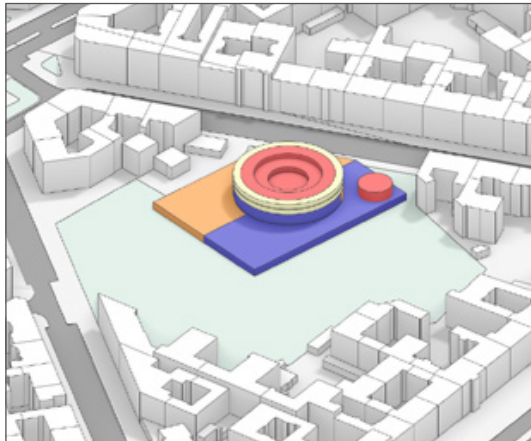

Height : 21m, 5m
Building footprint : 6.603m²

Extension Alternative 4 _ Offset

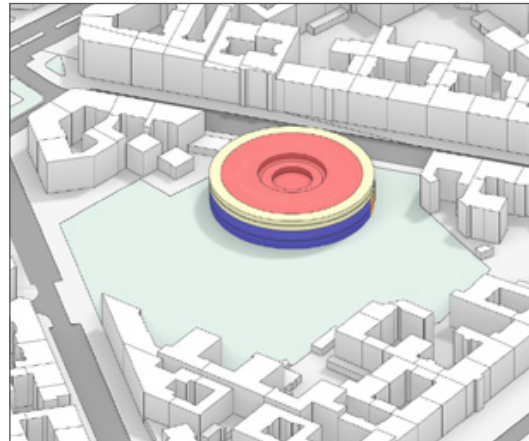

Height : 21m
Building footprint : 4.620m²

Extension Alternative 5 _ Vertical + Flat

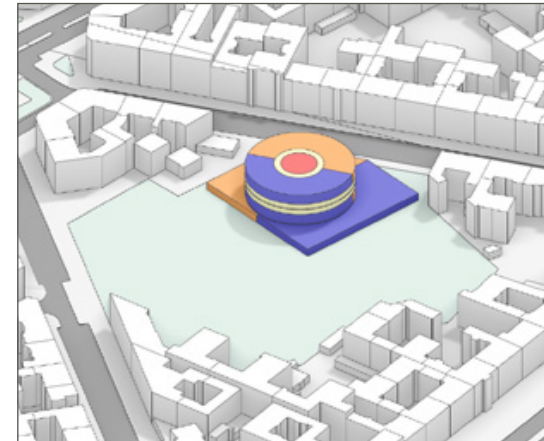

Height : 21m, 5m
Building footprint : 4.828m²

Design Concept
MASSING STUDIES



COMMEMORATIVE
LANDSCAPE



COMMEMORATIVE
LANDSCAPE

FROM ABANDONED TO AN OPEN BUNKER

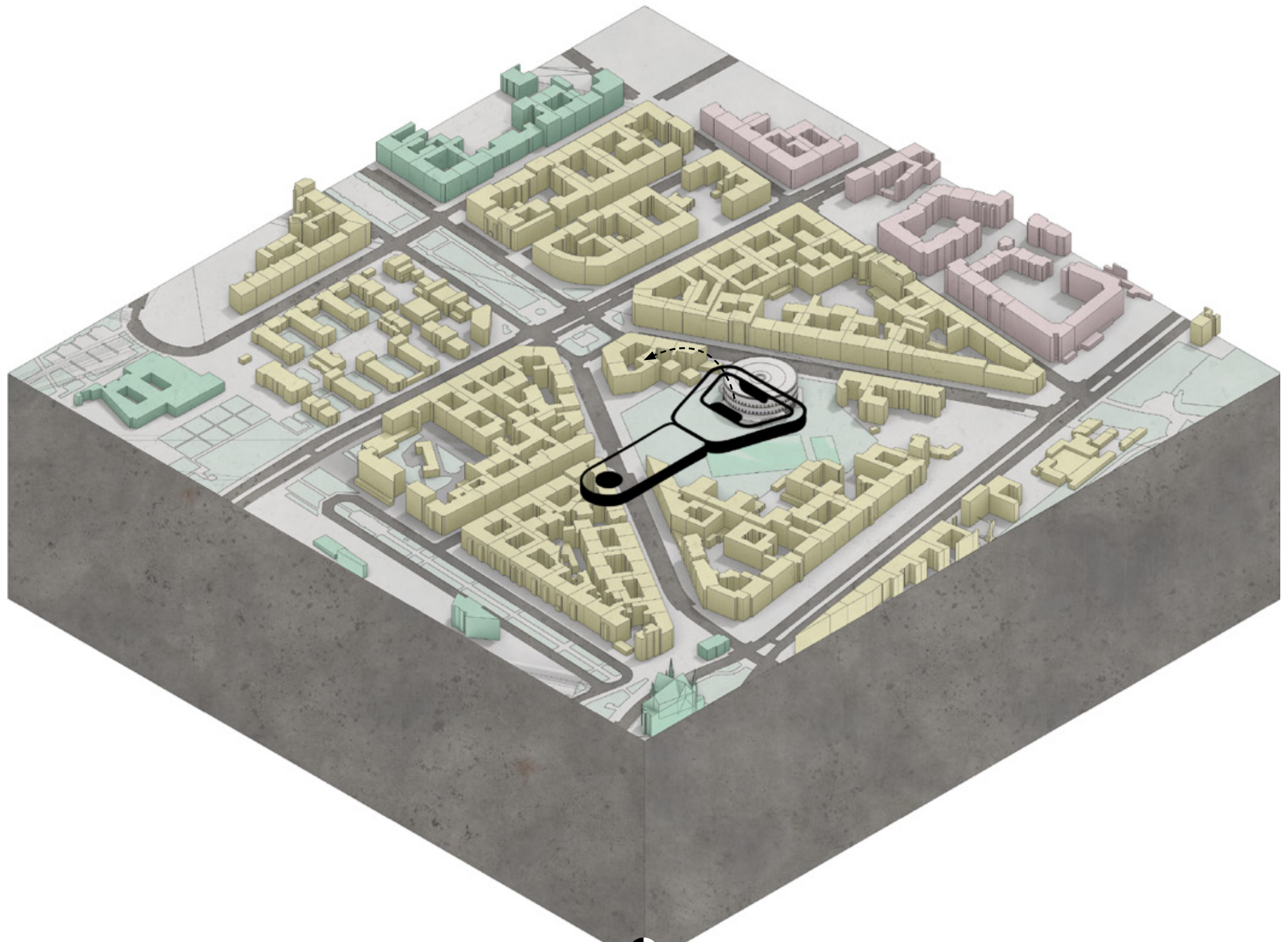

FROM ABANDONED TO AN OPEN BUNKER

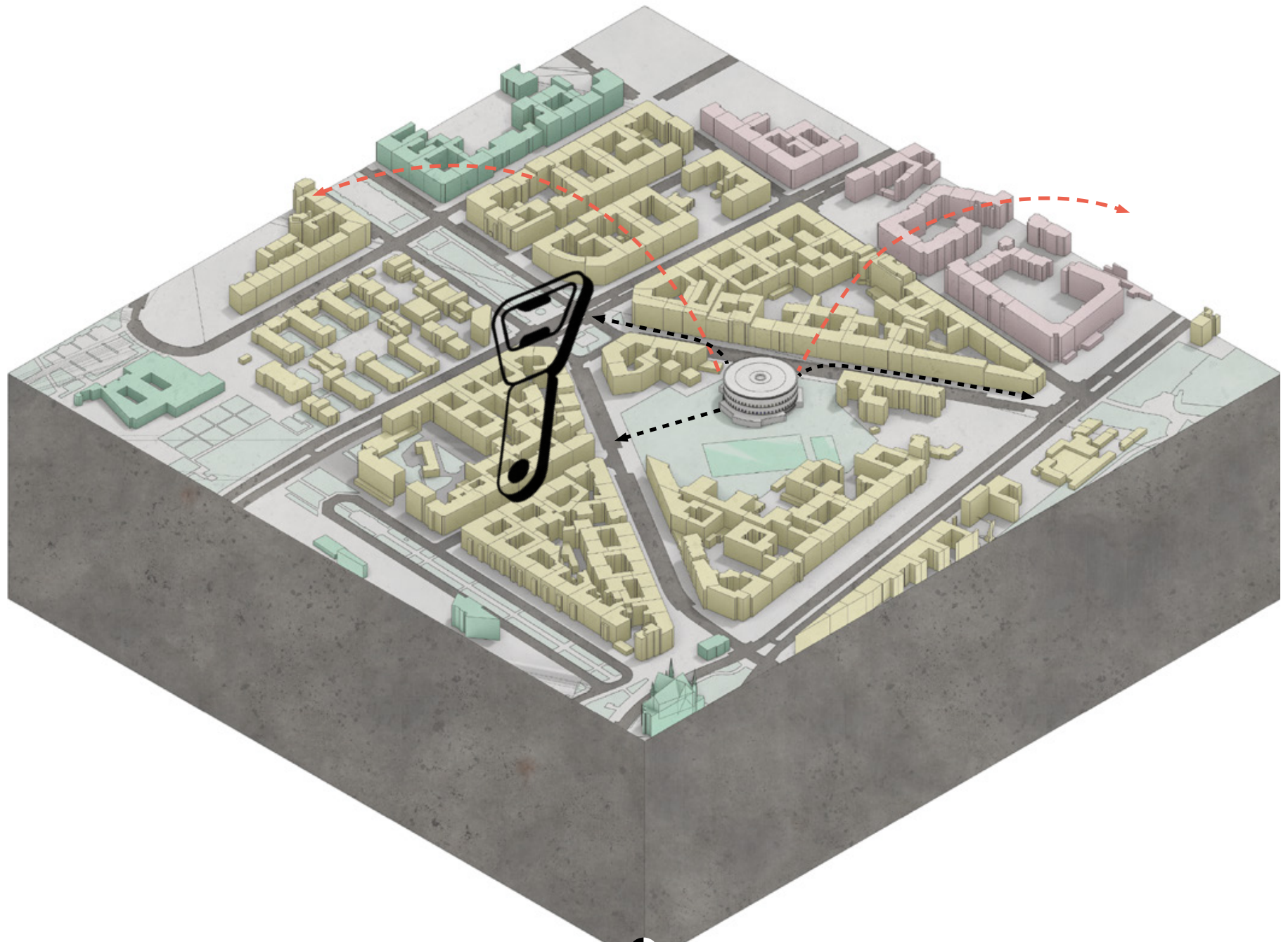

Design Concept

CURRENT SITE CONDITION

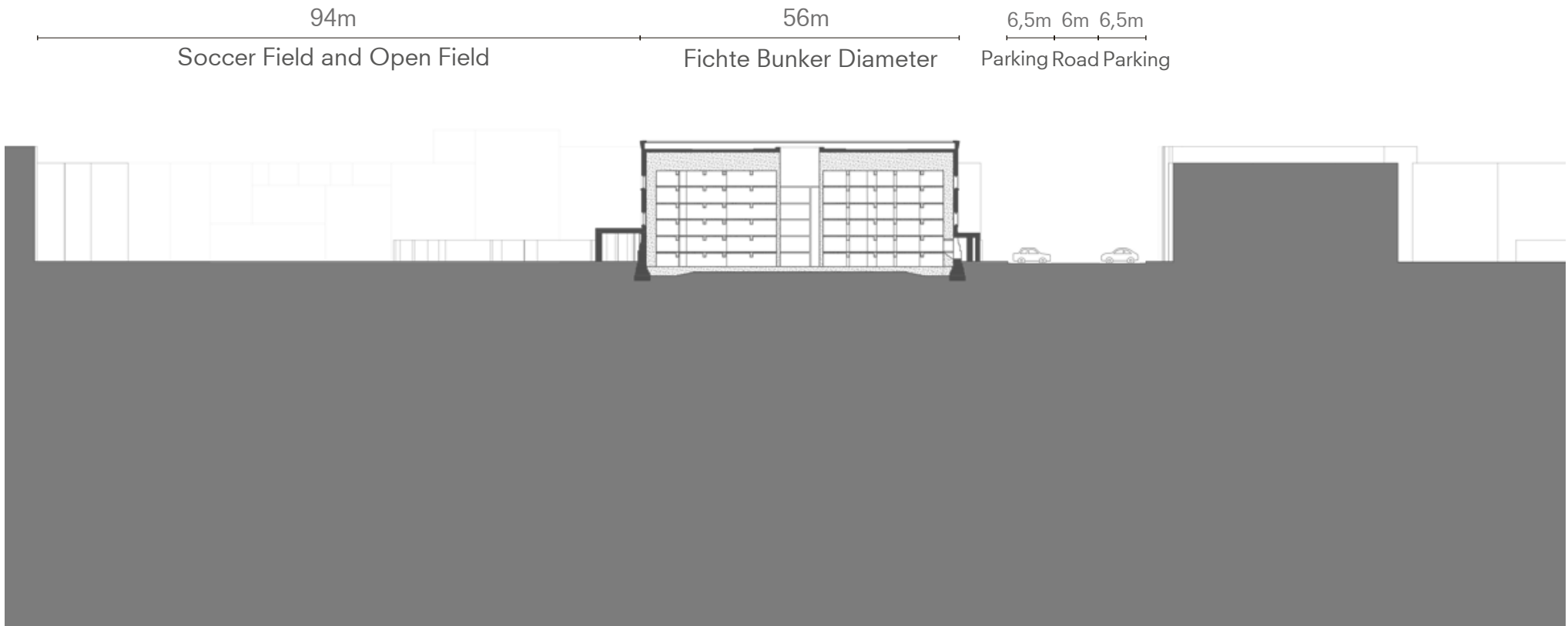

Design Concept
MUSIC BUNKER

50.8 m

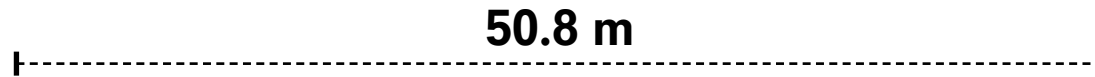
A horizontal dashed line with vertical end caps, indicating a width of 50.8 m.

18.6 m

A vertical dashed line with horizontal end caps, indicating a height of 18.6 m.

Available bunker interior space

Design Concept
MUSIC BUNKER

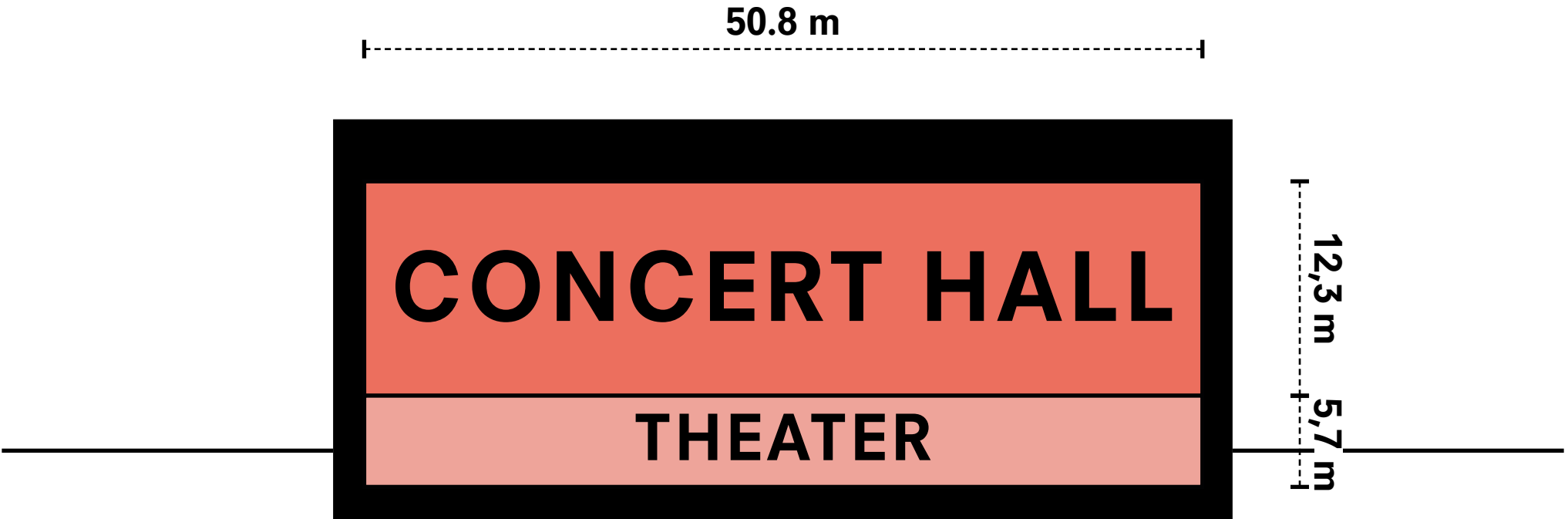

Utilize the bunker's interior as a cultural venue for historical experiences by vertically staking two performing arts spaces based on required height

Design Concept
MUSIC BUNKER



Performing arts space types for intimate theatrical/ musical experience

Design Concept

MUSIC BUNKER

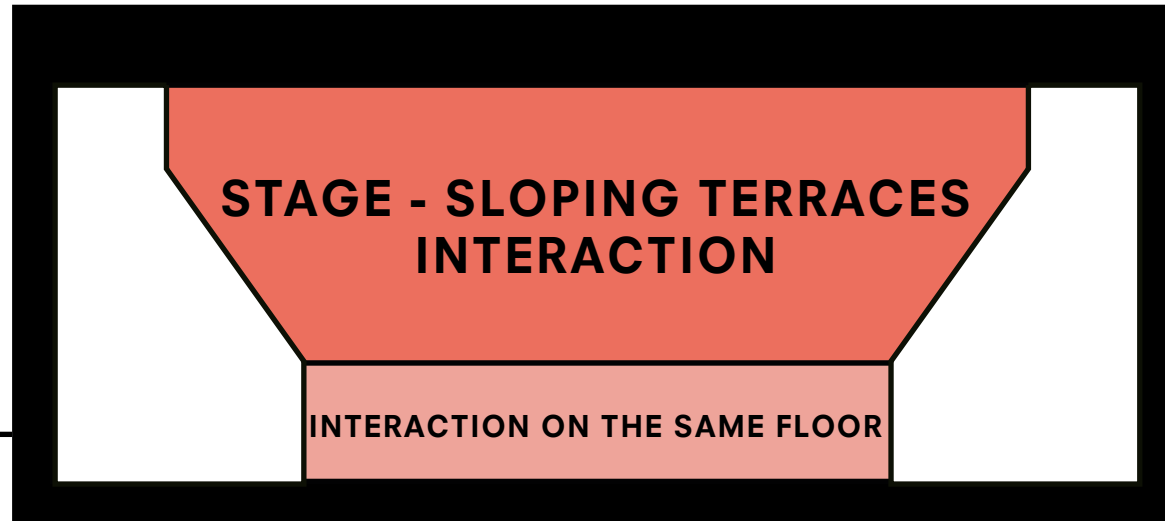

Performing arts space types for intimate theatrical/ musical experience

Design Concept
MUSIC BUNKER

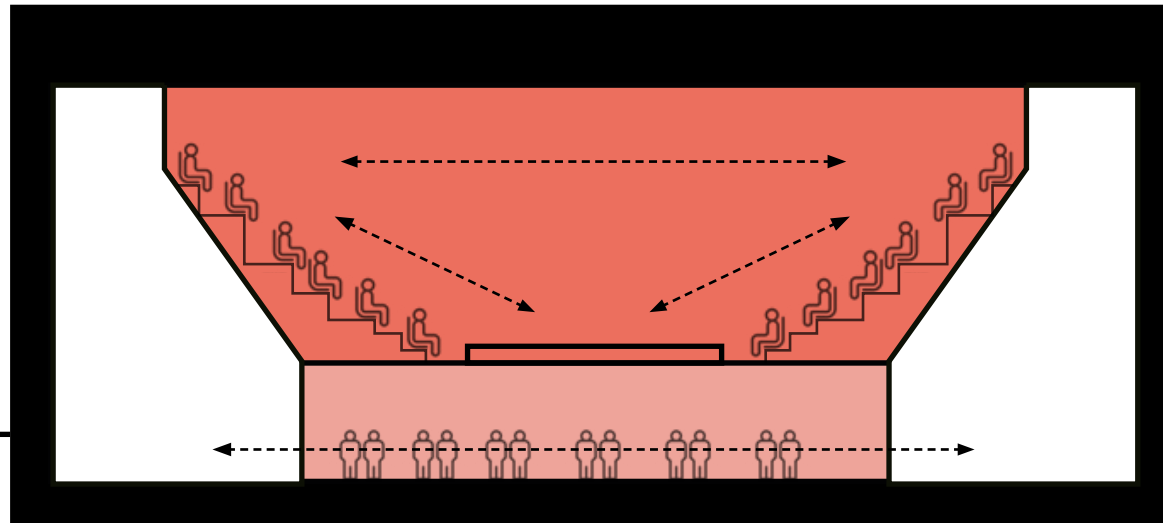

Performing arts space types for intimate theatrical/ musical experience

Design Concept

MUSIC BUNKER

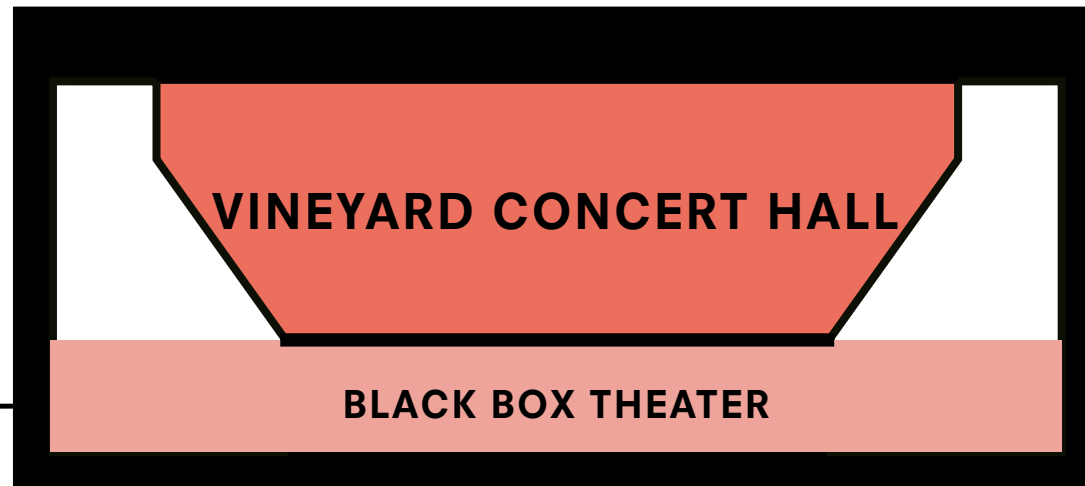

Design Concept
MUSIC BUNKER

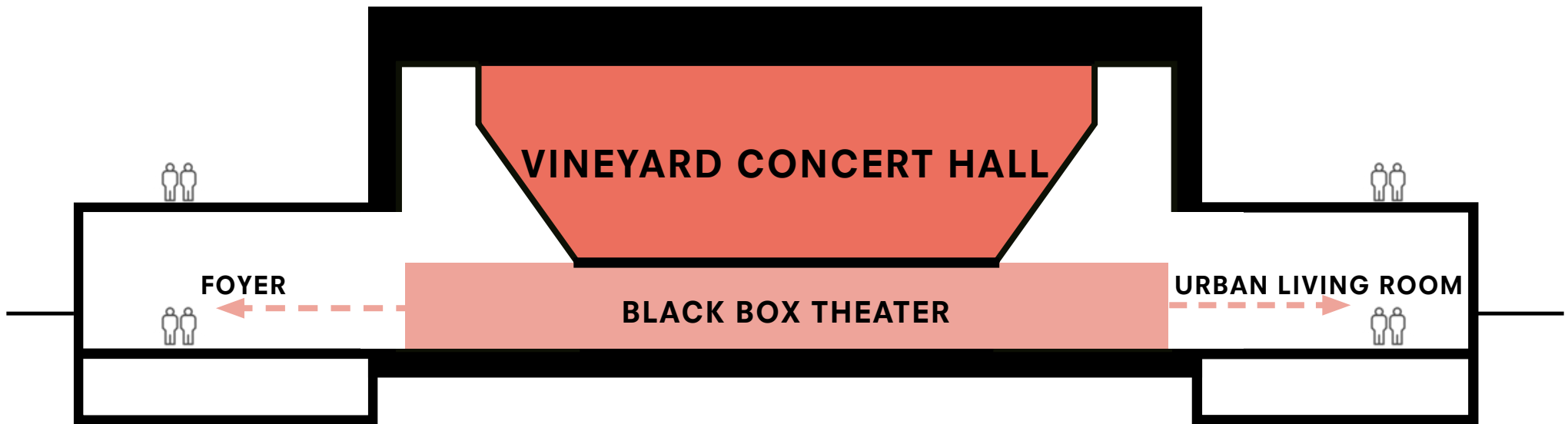

Horizontal extension - Expansion and utilization of bunker strata

Design Concept
MUSIC BUNKER

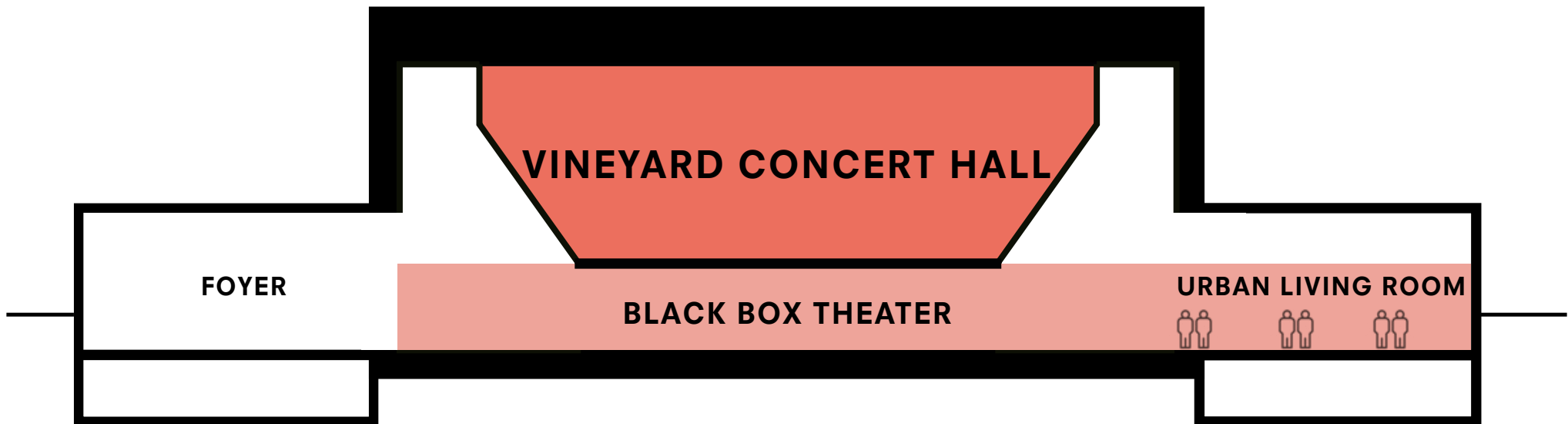

Horizontal extension - Expansion and utilization of bunker strata

Design Concept
MUSIC BUNKER

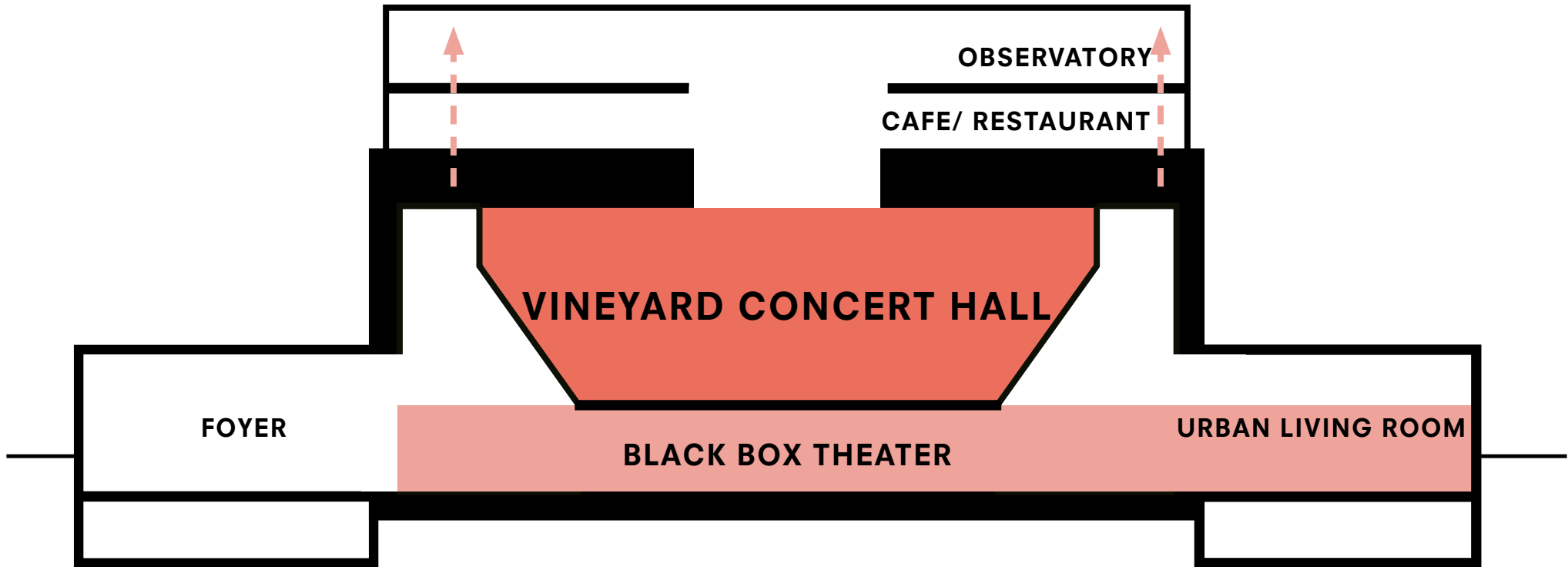

Vertical extension - Possibility of expansion of public space

Design Concept
MUSIC BUNKER

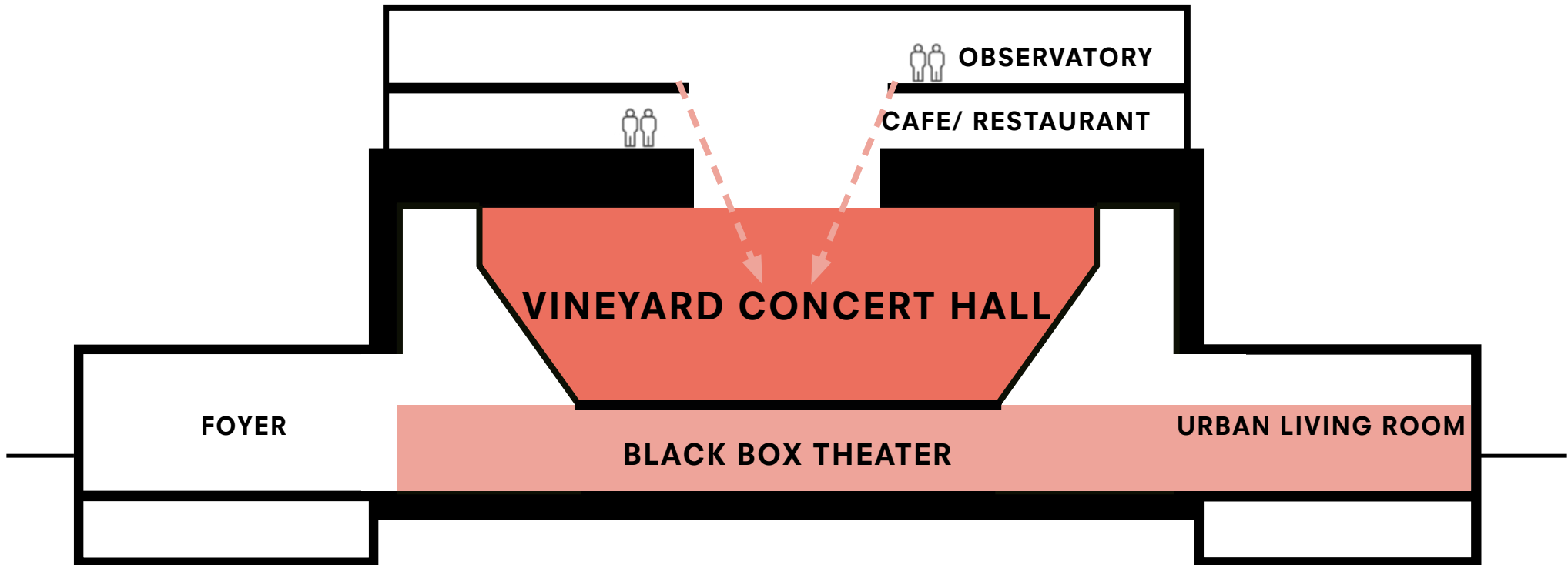

Vertical extension - Possibility of expansion of public space

Design Concept

MUSIC BUNKER

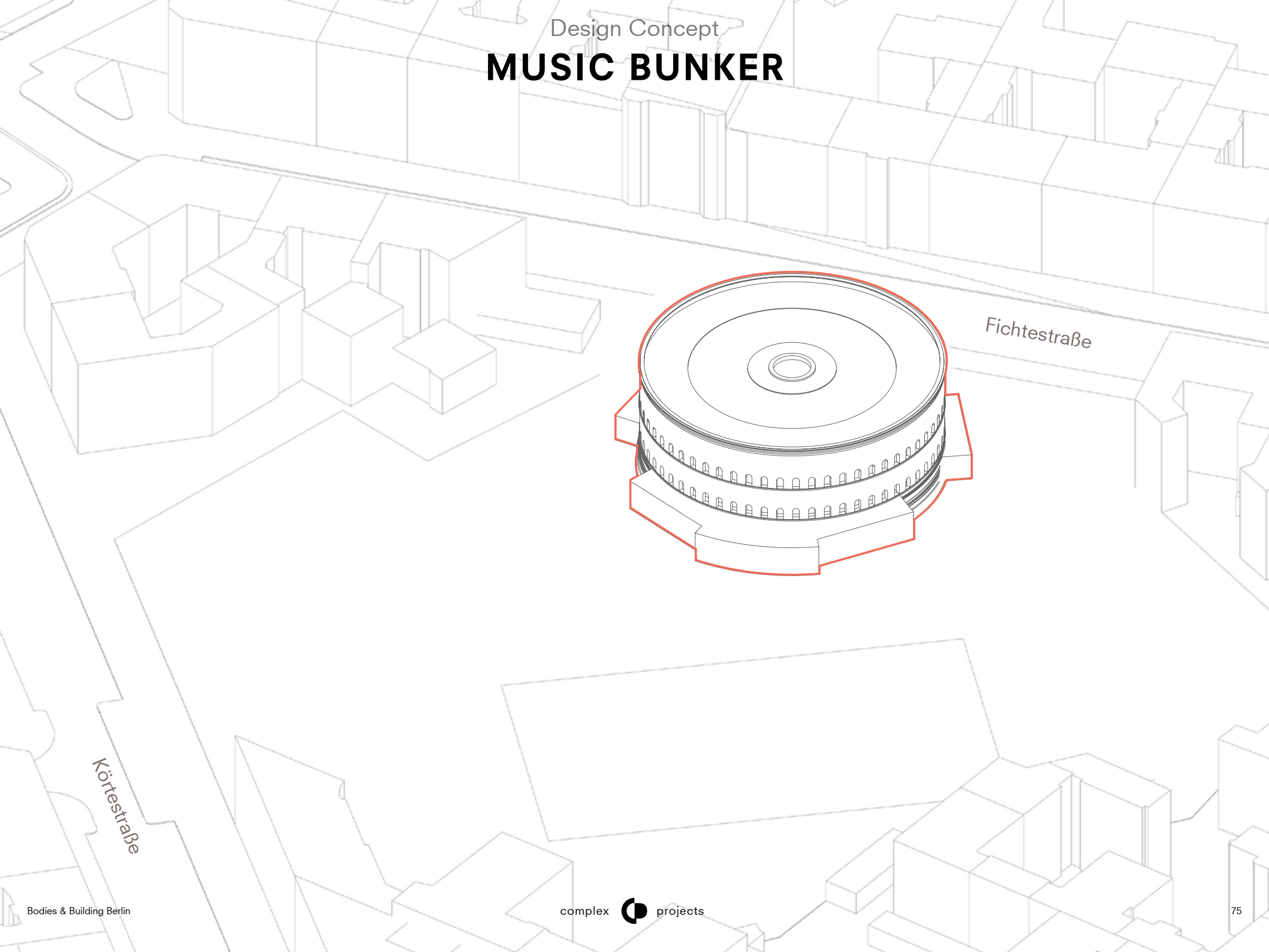

Fichtestraße

Körtestraße

MASSING DIAGRAM

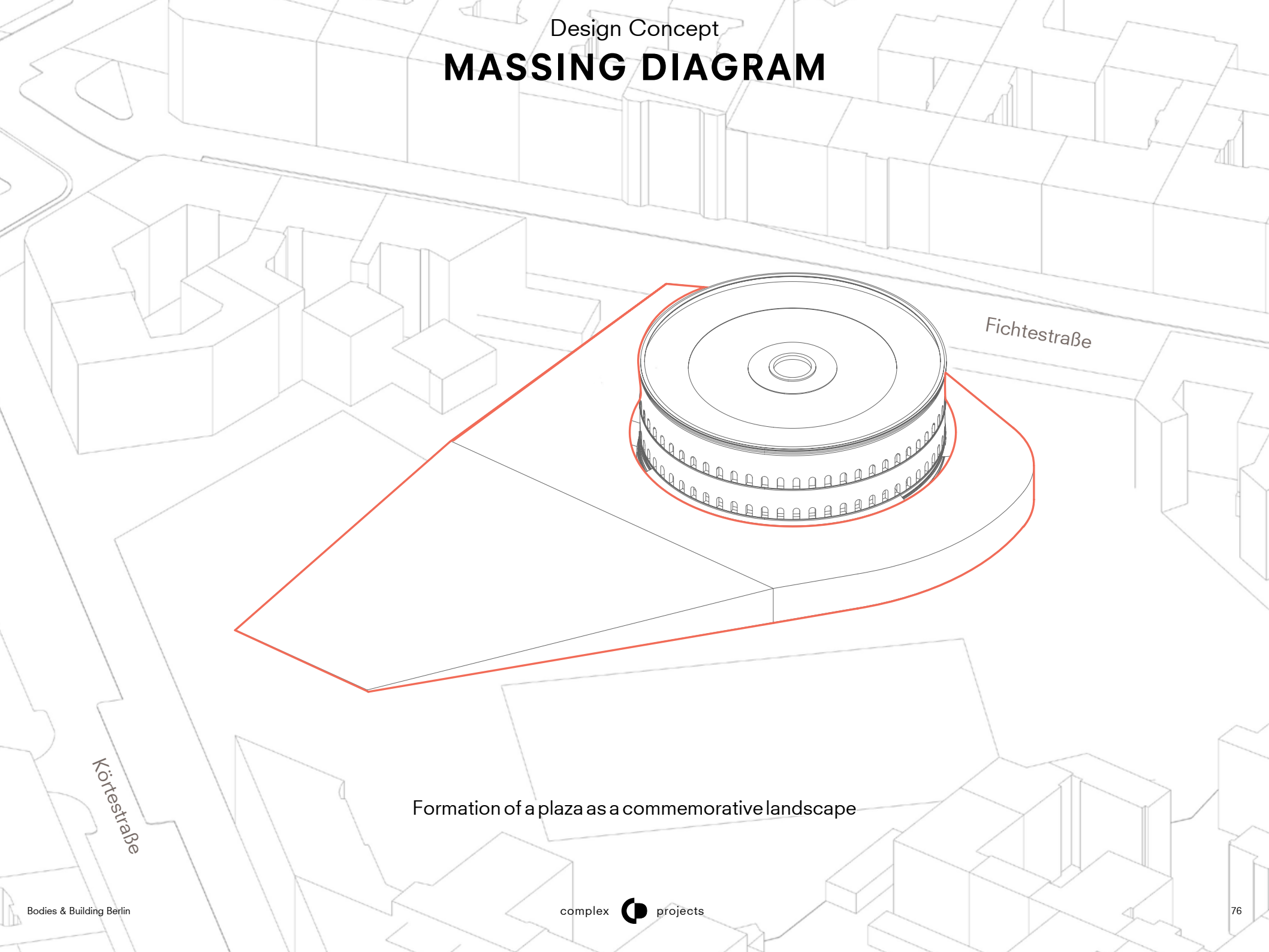

Fichtestraße

Körtestraße

Formation of a plaza as a commemorative landscape

MASSING DIAGRAM

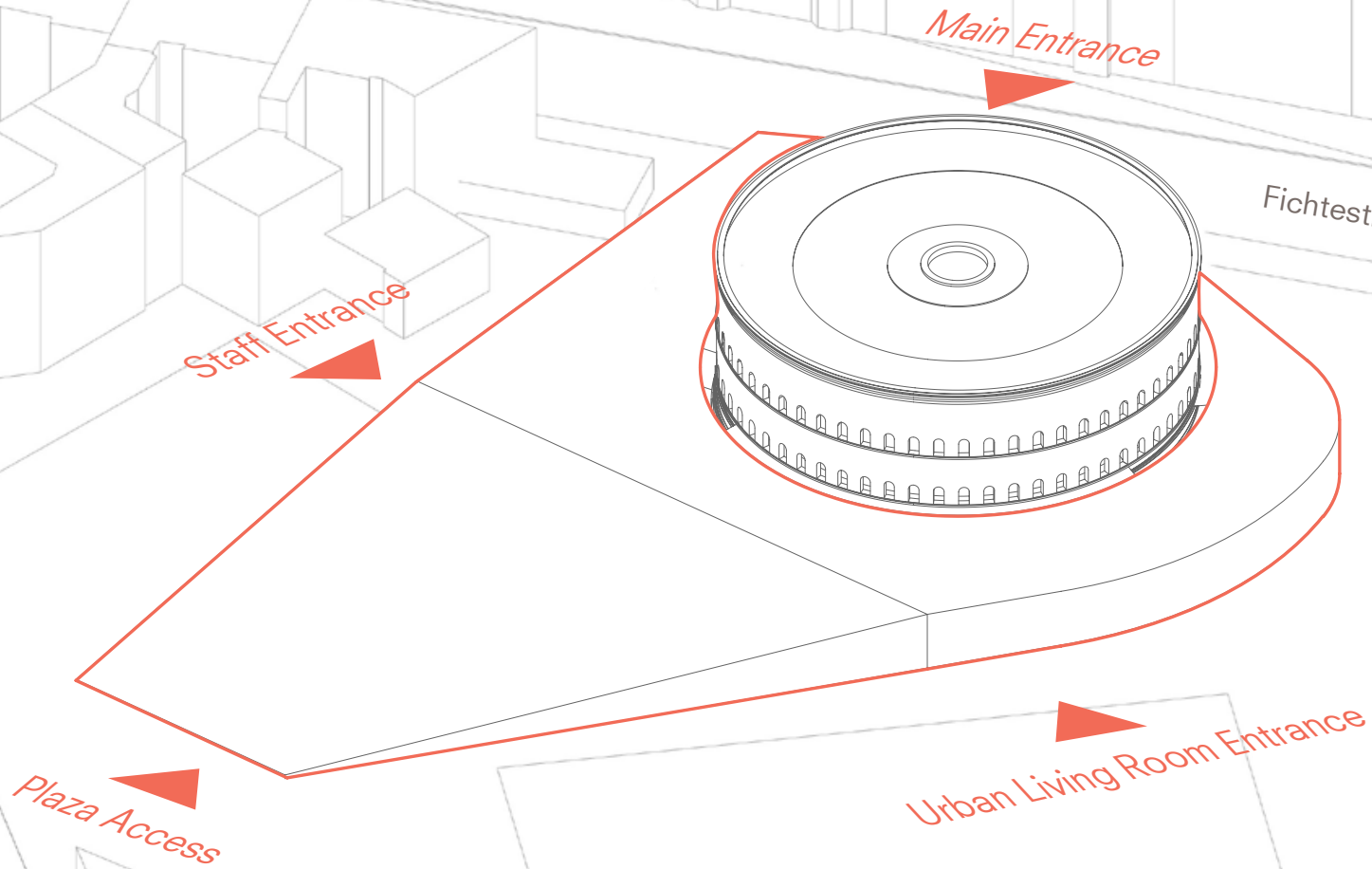

Classification of various user group circulation and improve accessibility of buildings

MASSING DIAGRAM

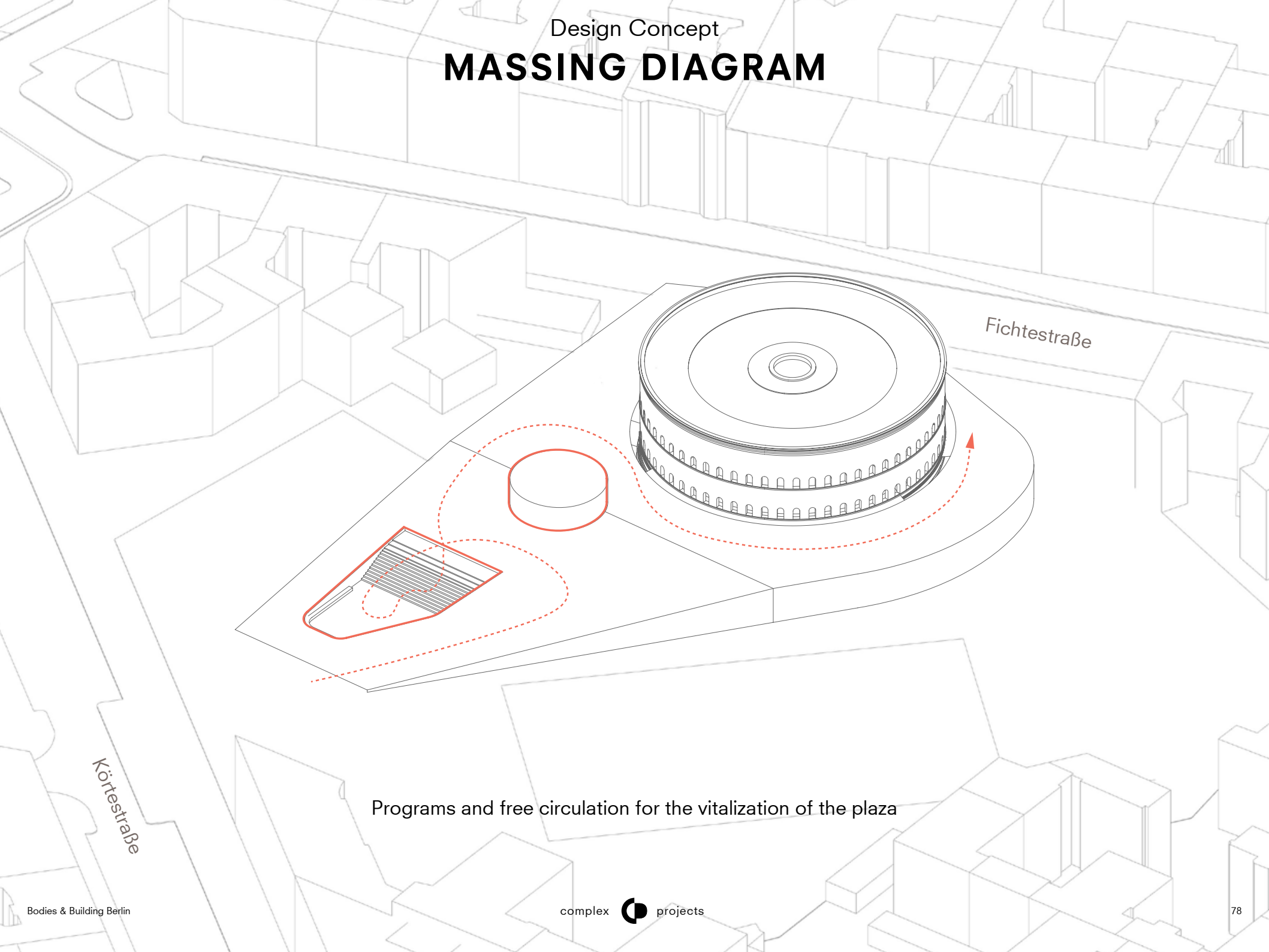

Fichtestraße

Körtestraße

Programs and free circulation for the vitalization of the plaza

MASSING DIAGRAM

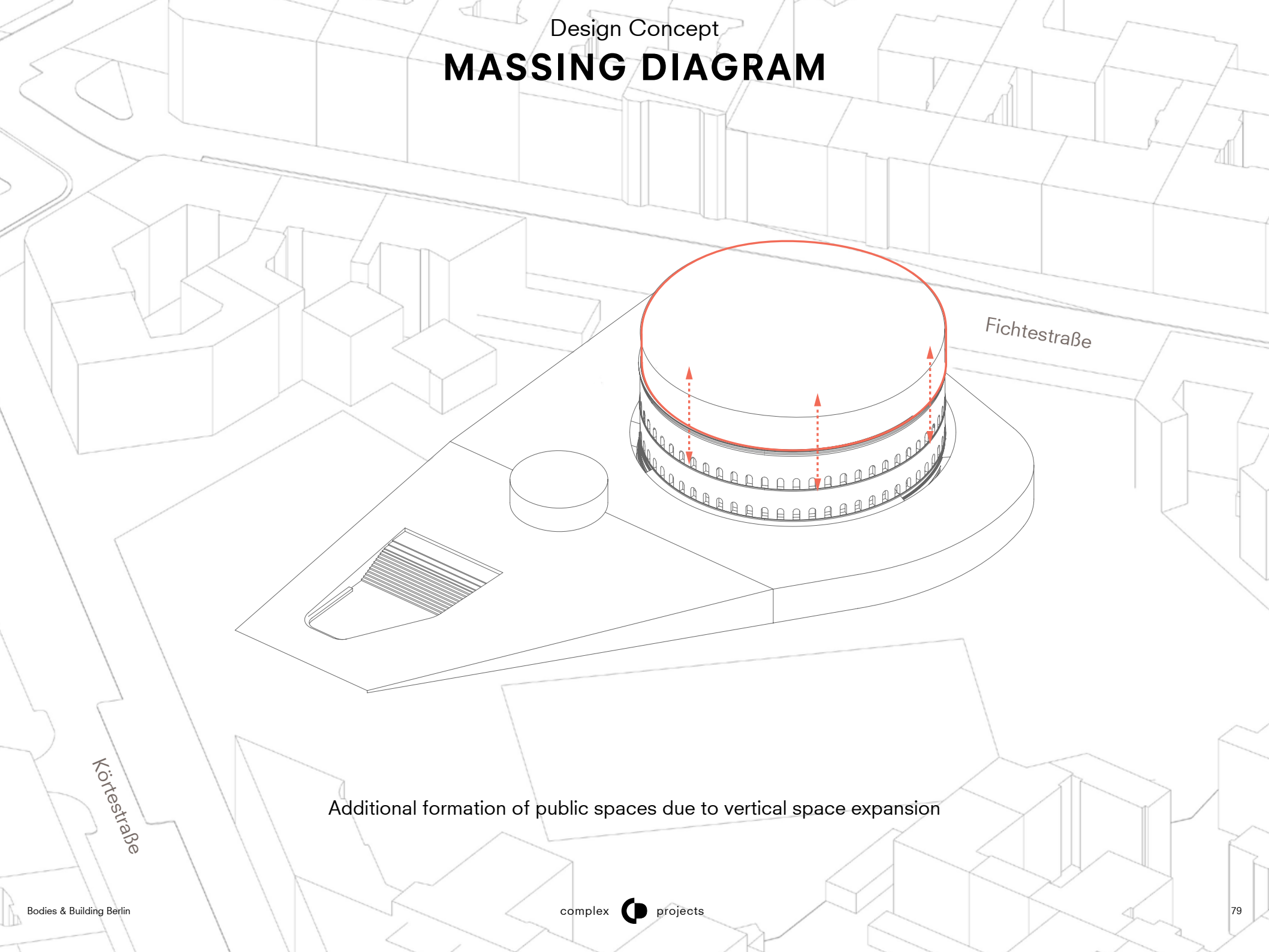

Additional formation of public spaces due to vertical space expansion

Design Concept

PROGRAM MASSING DIAGRAM

Auditorium Area

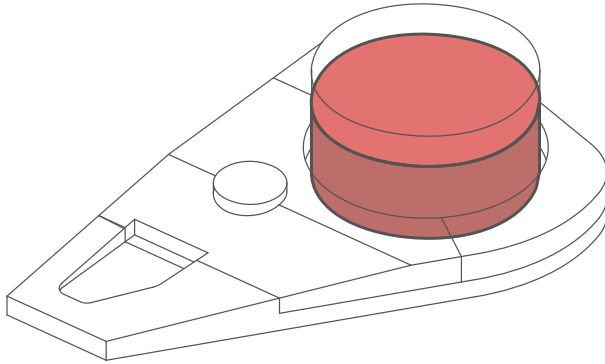

Main Concert Hall + Black Box theater

PROGRAM MASSING DIAGRAM

Auditorium Area

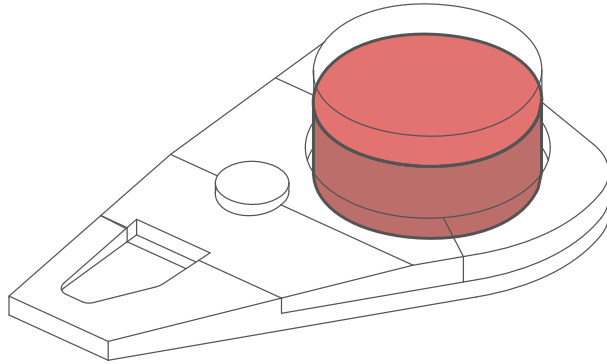

Support Space

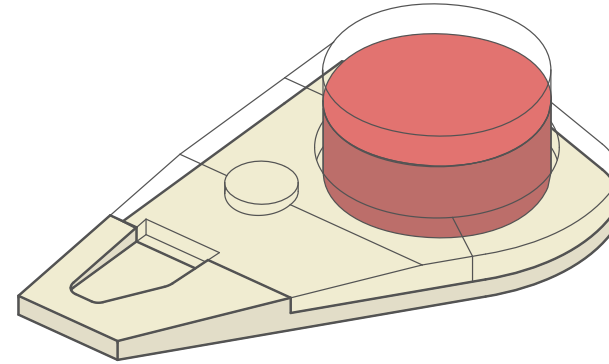

Circulation + Technical + Parking Lot

PROGRAM MASSING DIAGRAM

Auditorium Area

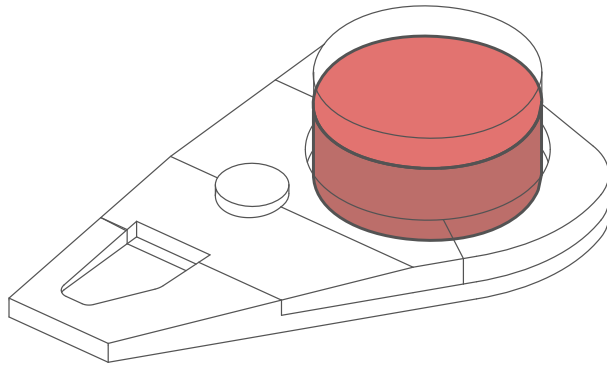

Support Spcae

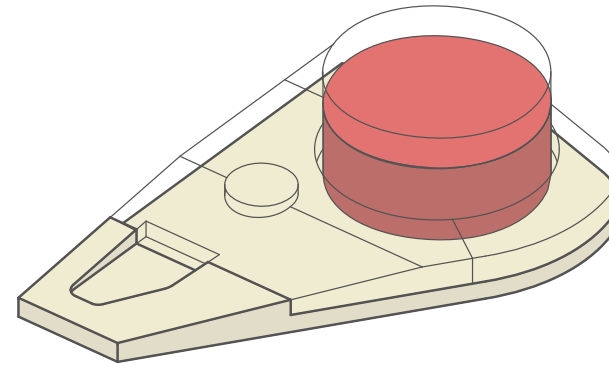

Public Space

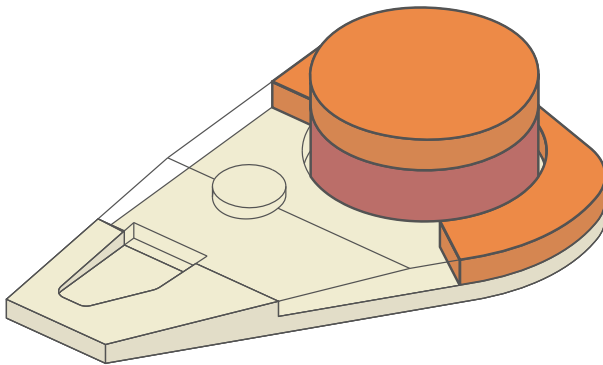

Foyer + Urban living Room + Restaurant

PROGRAM MASSING DIAGRAM

Auditorium Area

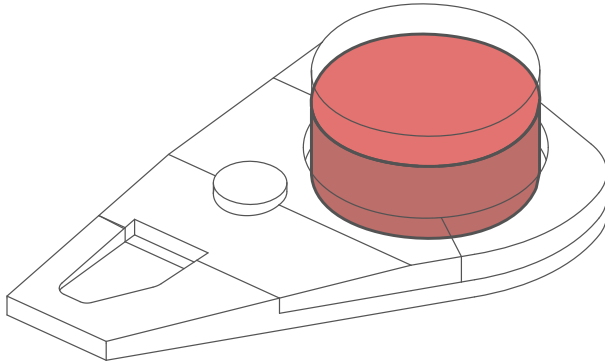

Support Spcae

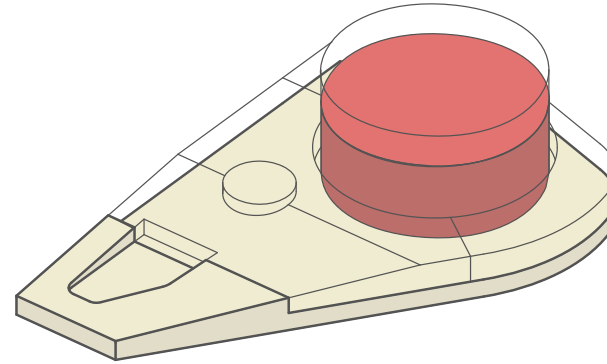

Public Space

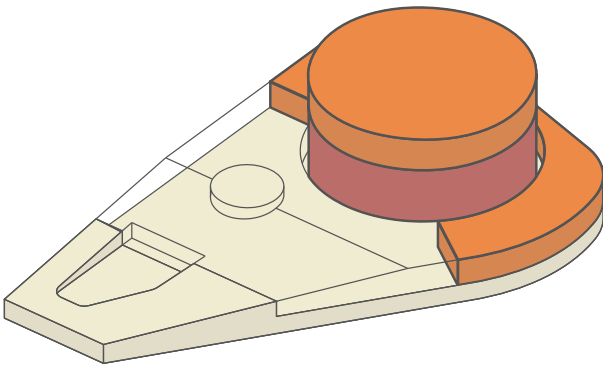

Back of House

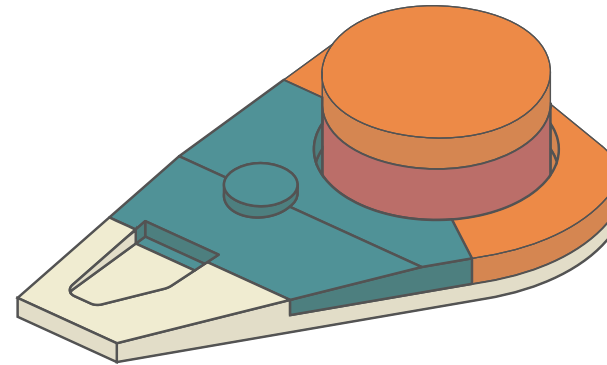

Workshops + Administration

DESIGN STRATEGY



Mercury Store, CO Adaptive Architecture



Royal National Theatre, Denys Lasdun



Perelman Performing Arts Center, REX



DCPA Theatre , Semple Brown Architects







Design Concept

CONTRAST BETWEEN OLD AND NEW



CONTRAST BETWEEN OLD AND NEW

Heaviness and Lightness
Solid and Transparency
Shadow and Light



IMPLEMENTATION

Implementation

GROUP SITE PLAN

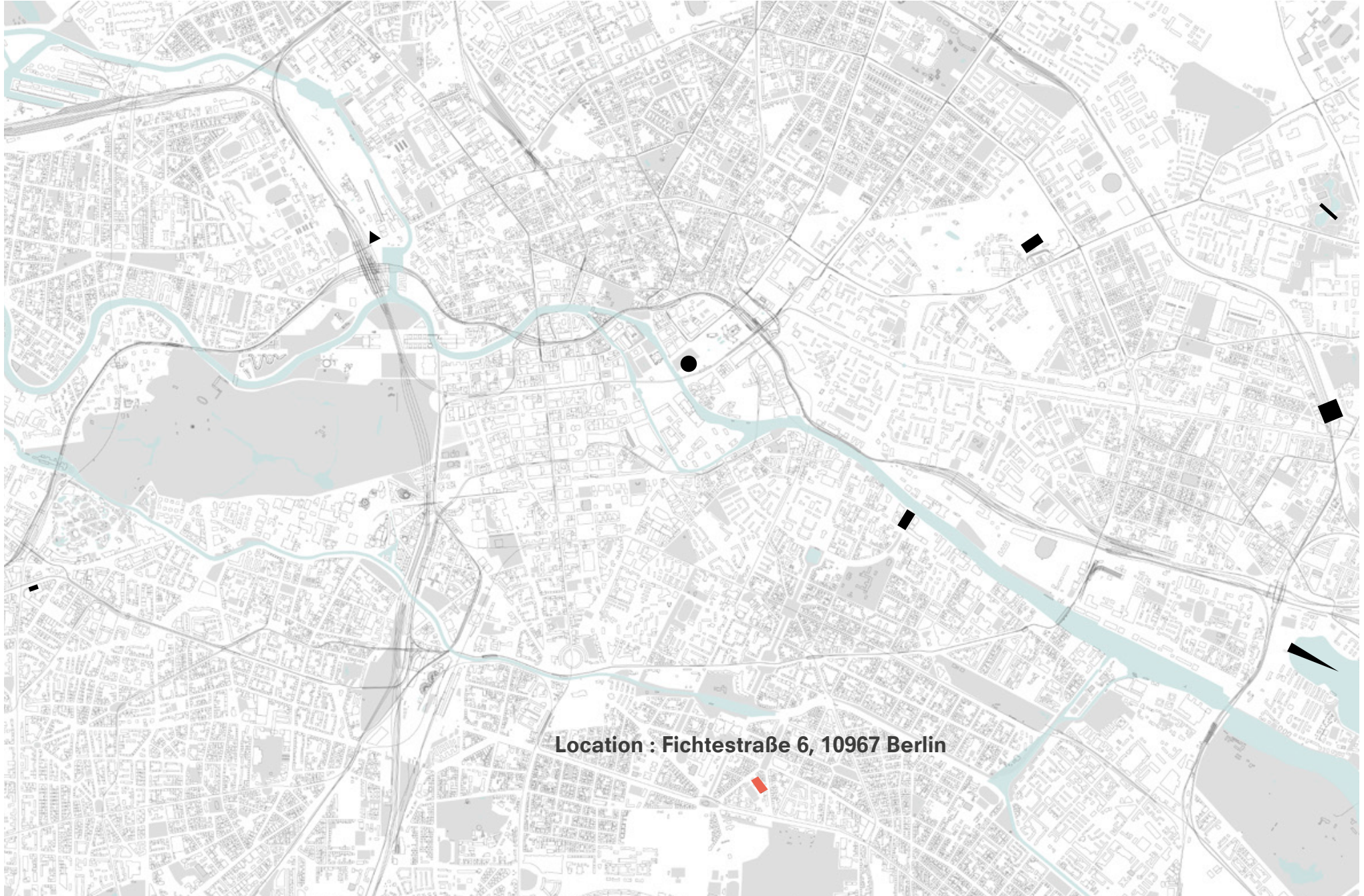

Location : Fichtestraße 6, 10967 Berlin

Implementation SITE PLAN



Building Footprint Area : 8.700m²
Gross Floor Area : 15.244m²
Accessible Area of Plaza : 4.500m²

Implementation

ZONING AND CIRCULATION

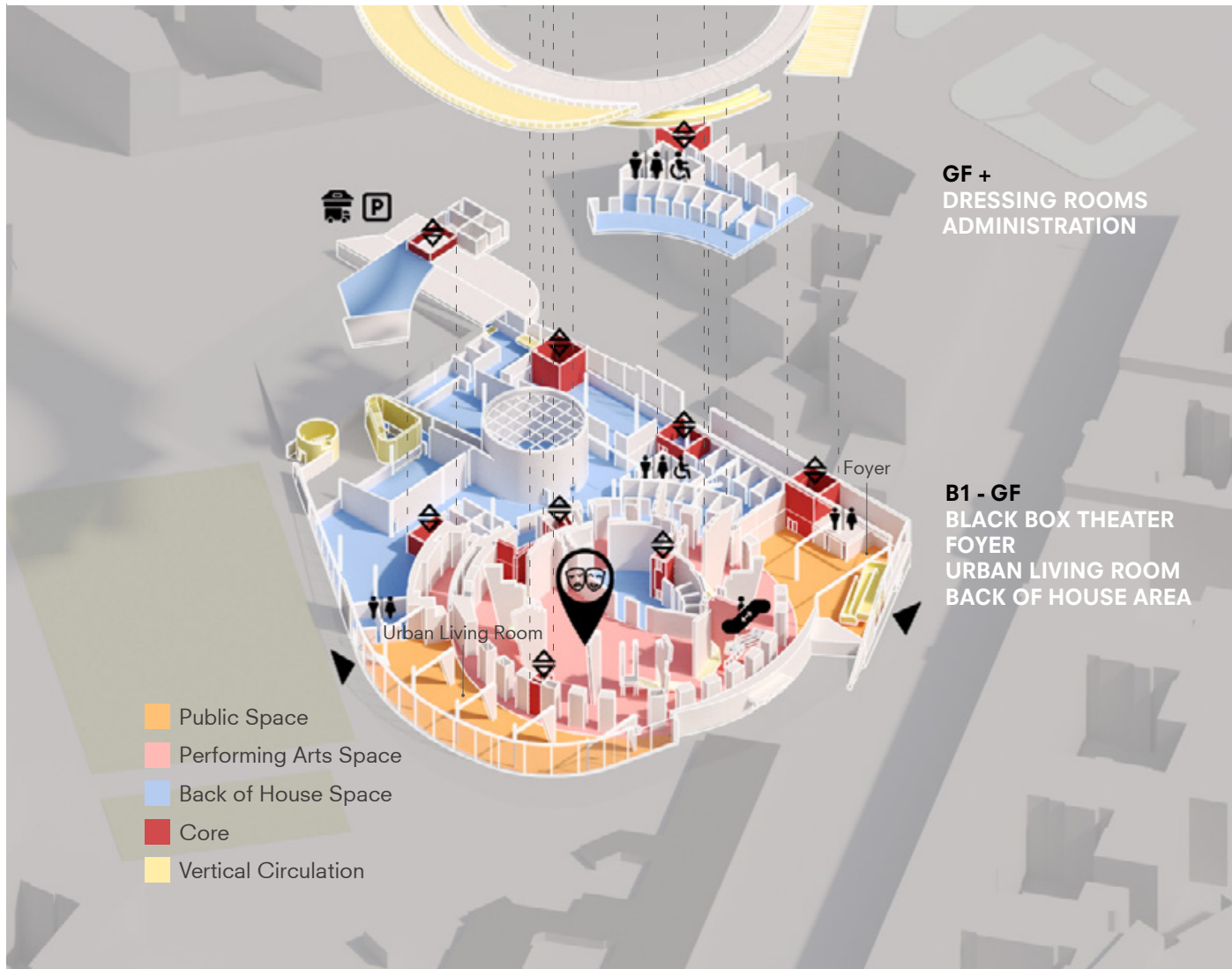

Implementation

ZONING AND CIRCULATION

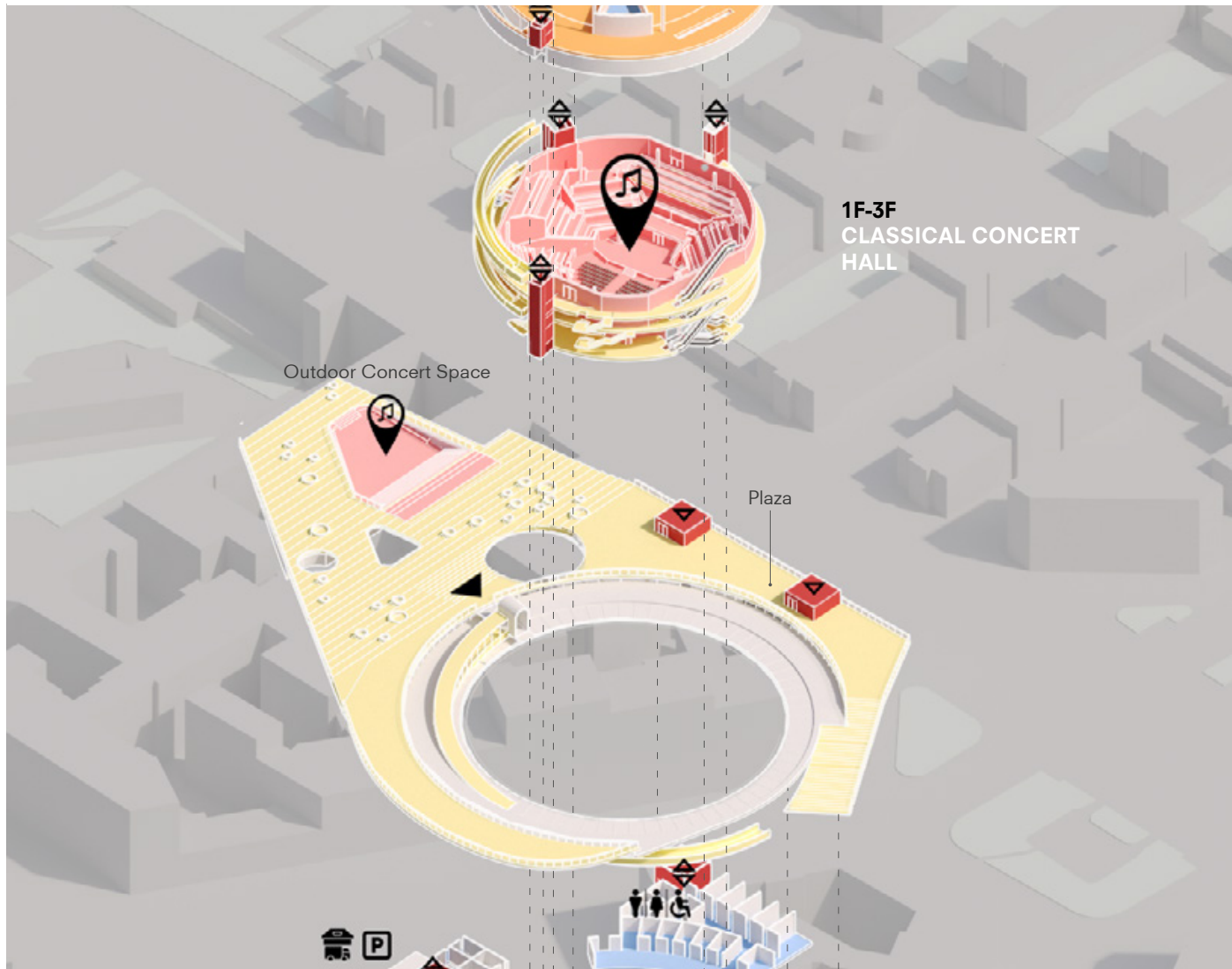

Implementation

ZONING AND CIRCULATION

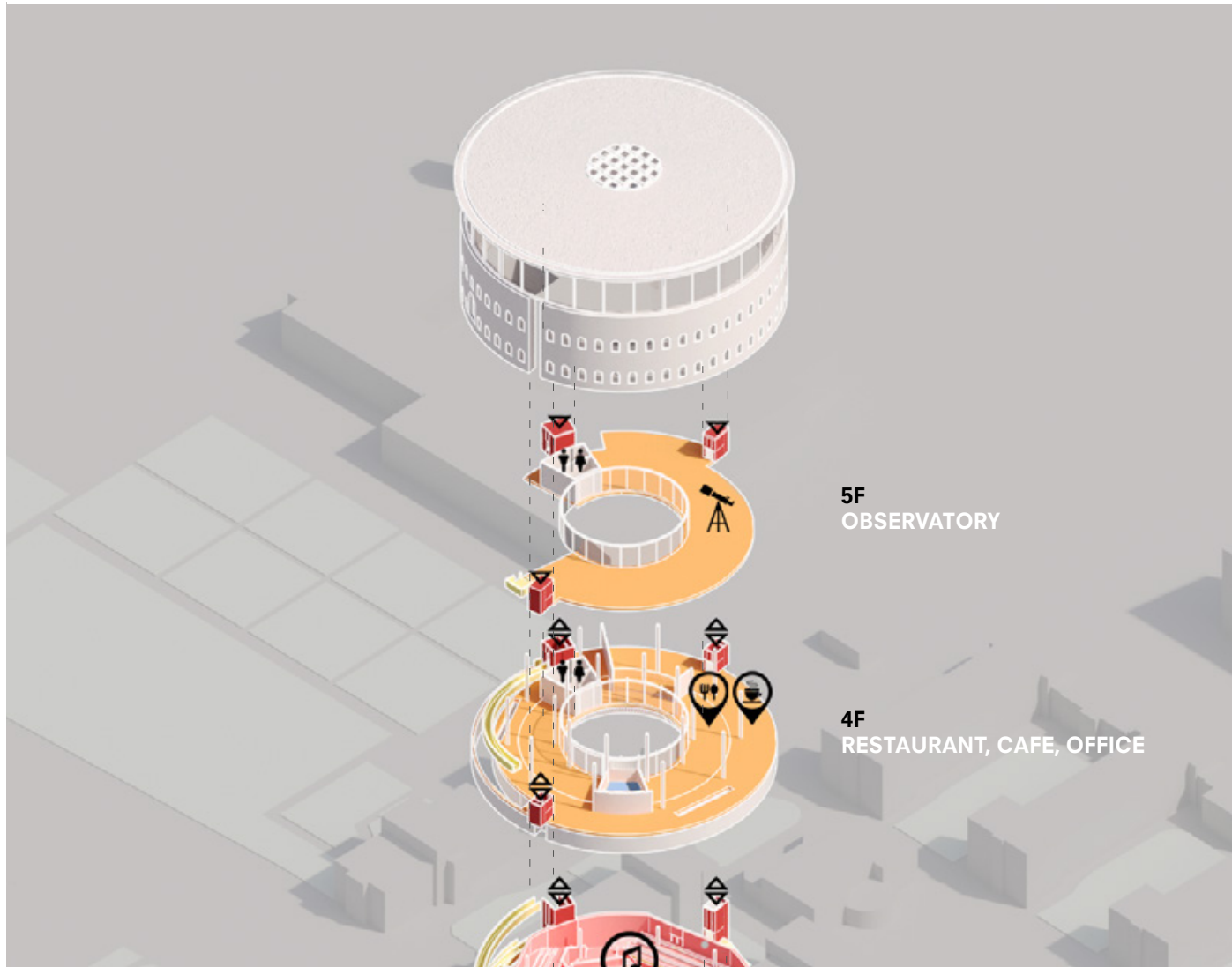

Implementation

URBAN IMPLEMENTATION

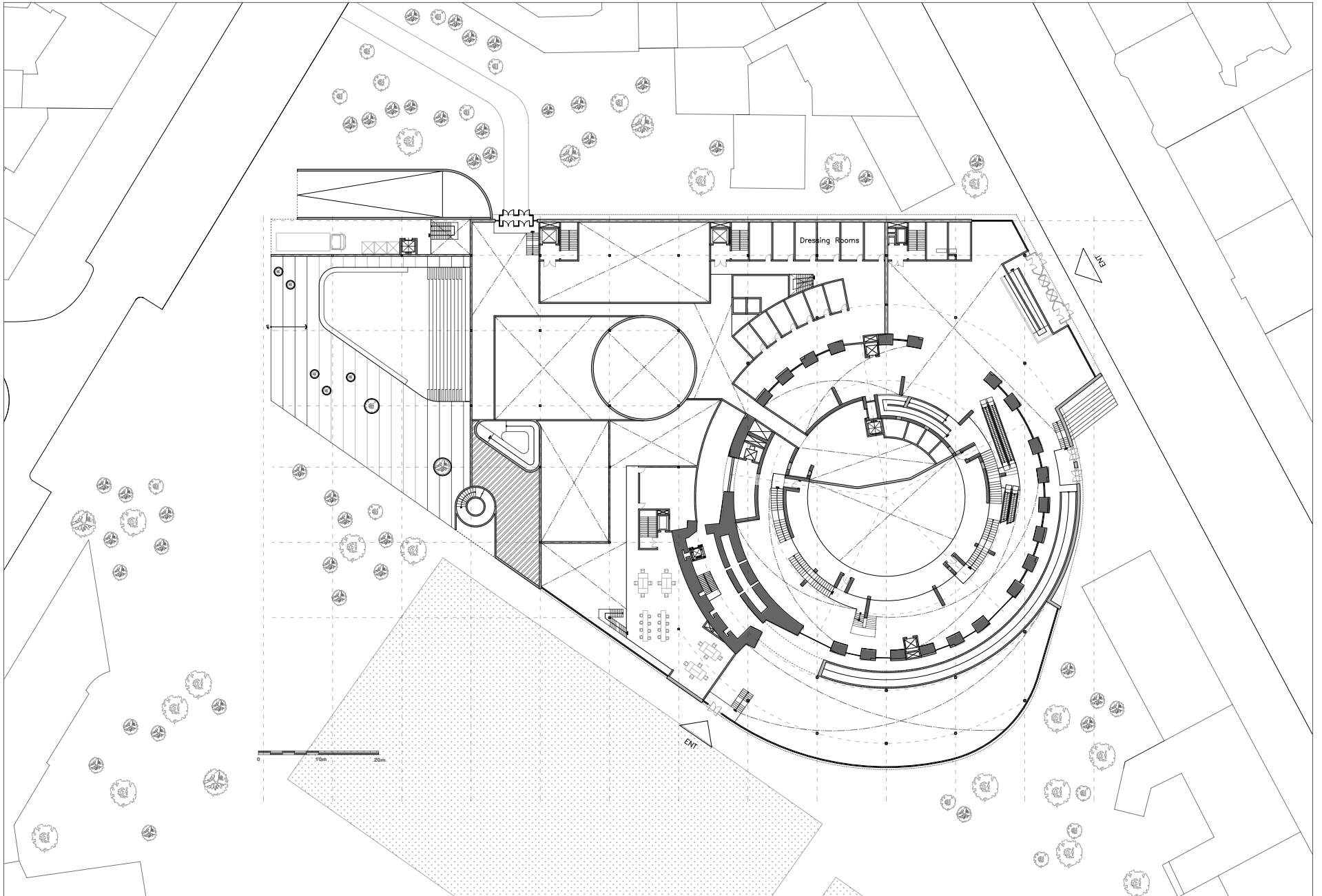

URBAN IMPLEMENTATION

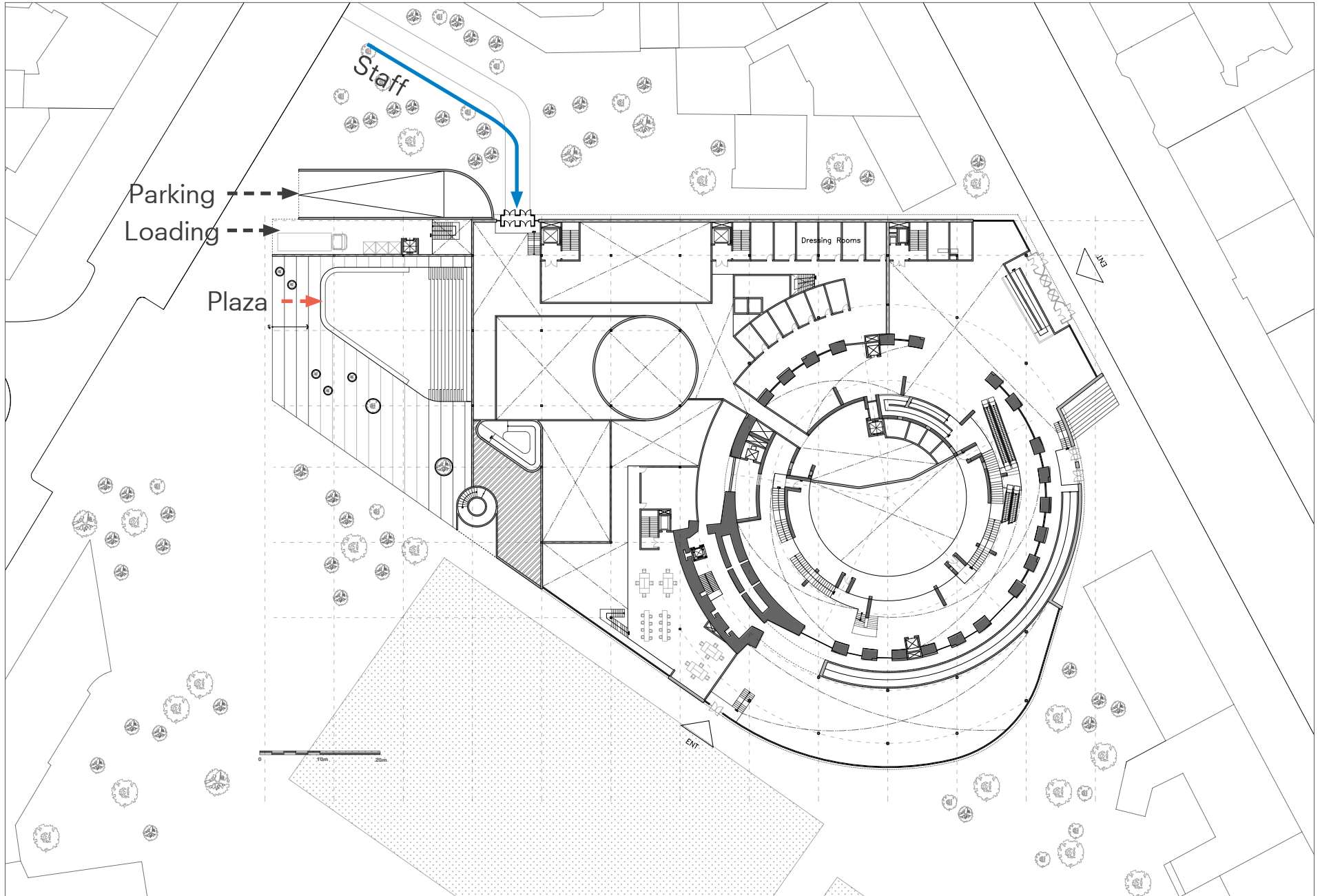

Implementation
PLAZA ACCESS



URBAN IMPLEMENTATION

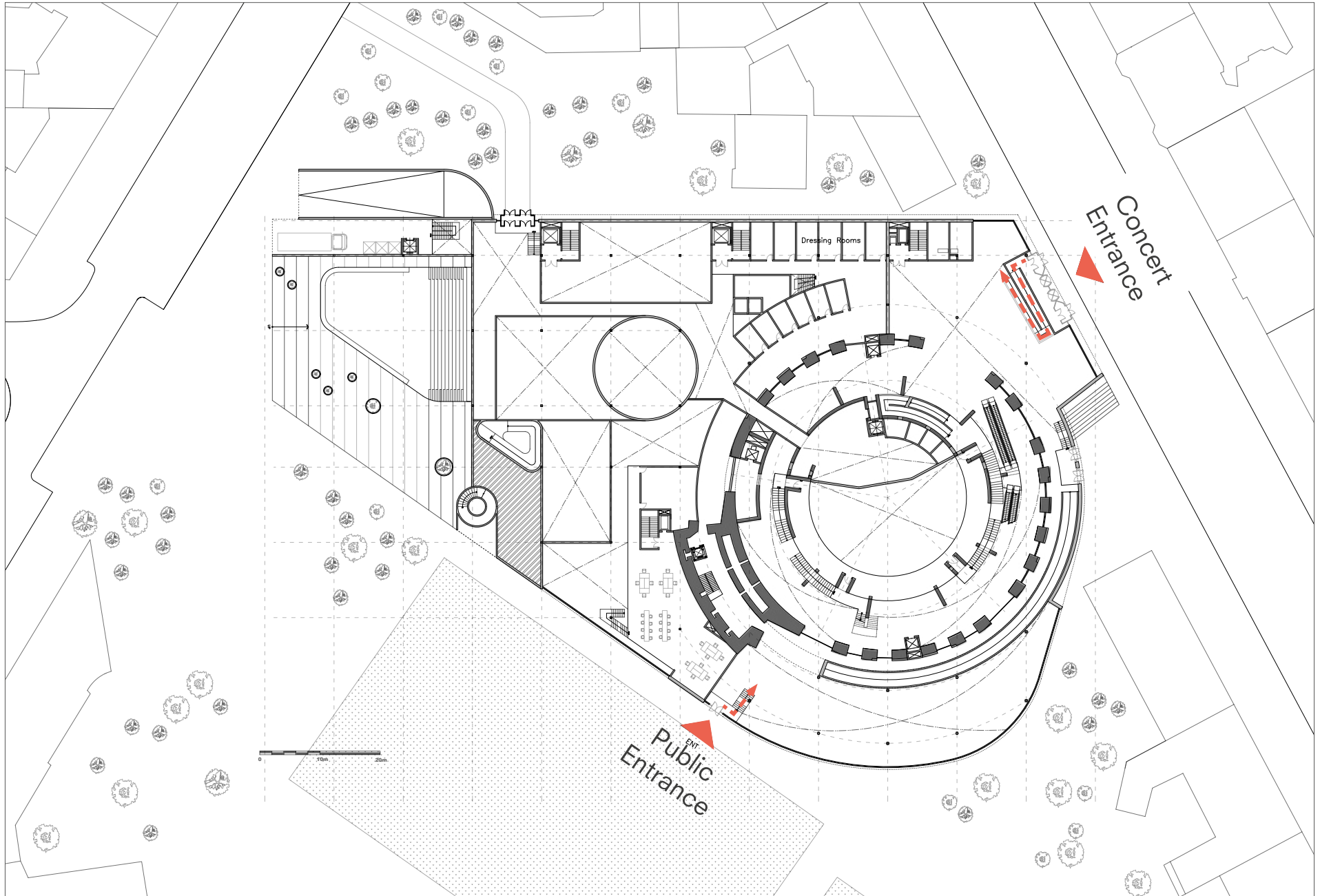

Implementation
EAST FACADE



Implementation

FIRST BASEMENT FLOOR PLAN

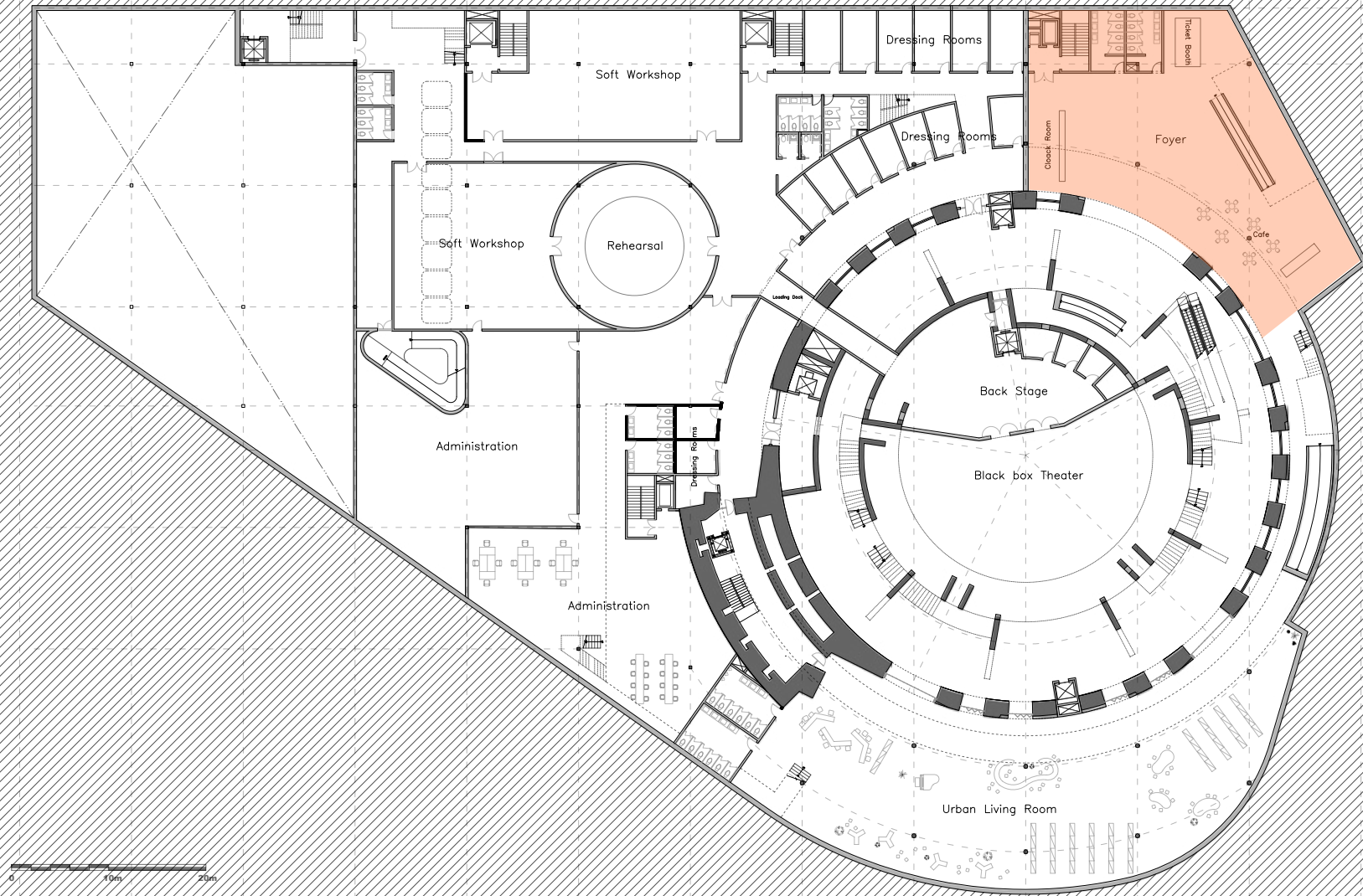

Implementation

FOYER



Implementation

FIRST BASEMENT FLOOR PLAN

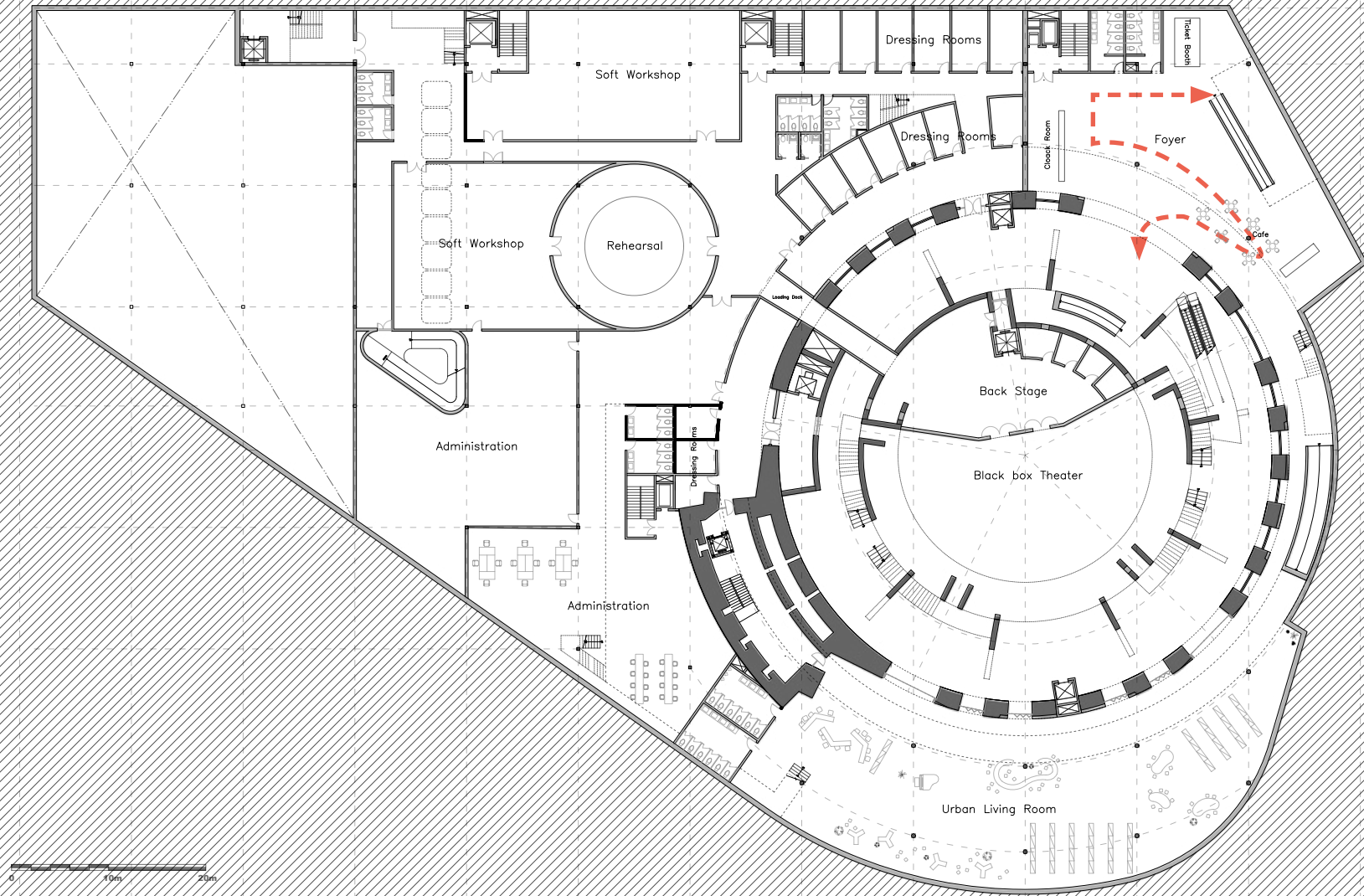

Implementation
HALLWAY



Implementation

FIRST BASEMENT FLOOR PLAN

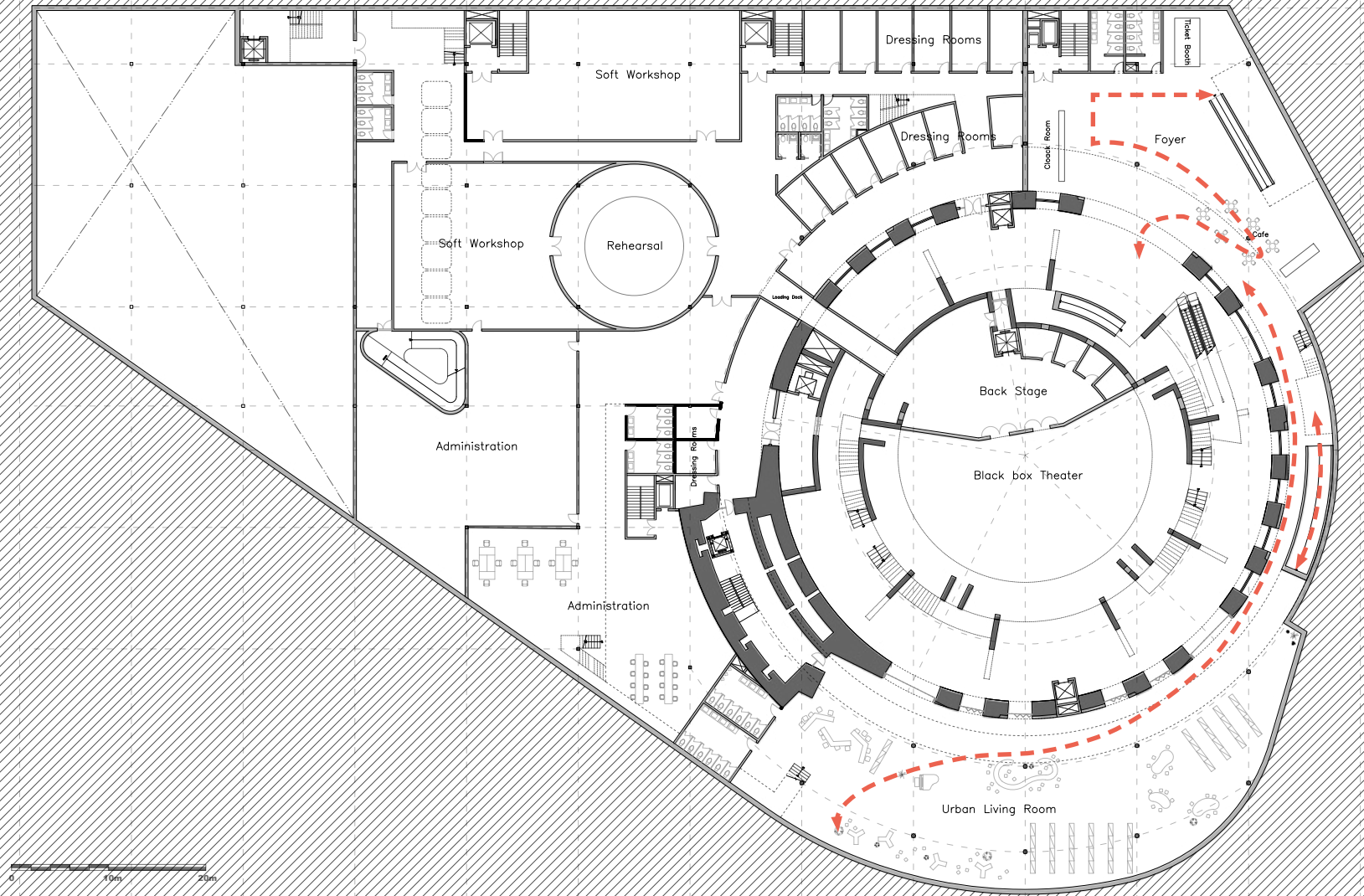

Implementation

FIRST BASEMENT FLOOR PLAN

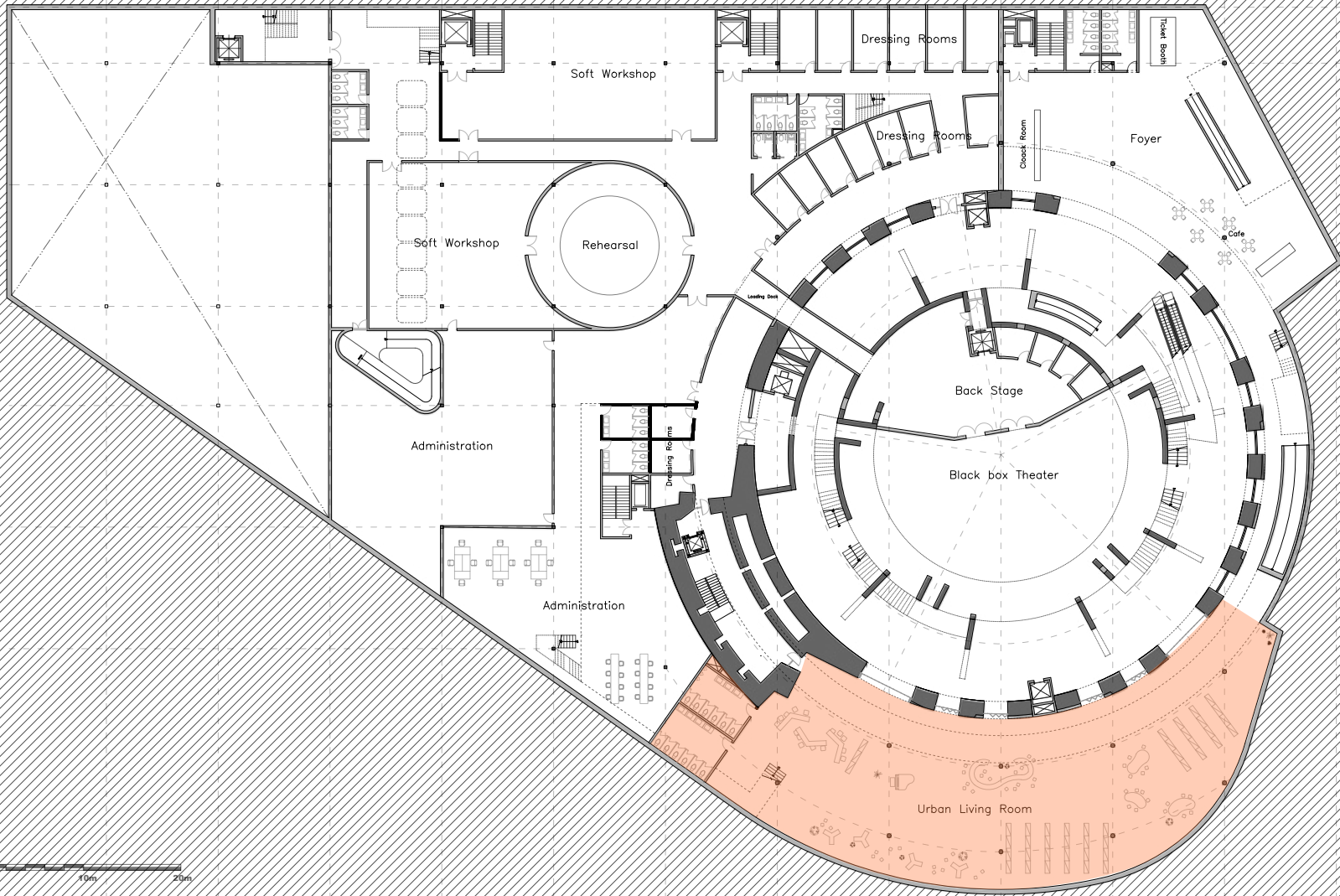

Implementation
URBAN LIVING ROOM



Implementation

FIRST BASEMENT FLOOR PLAN

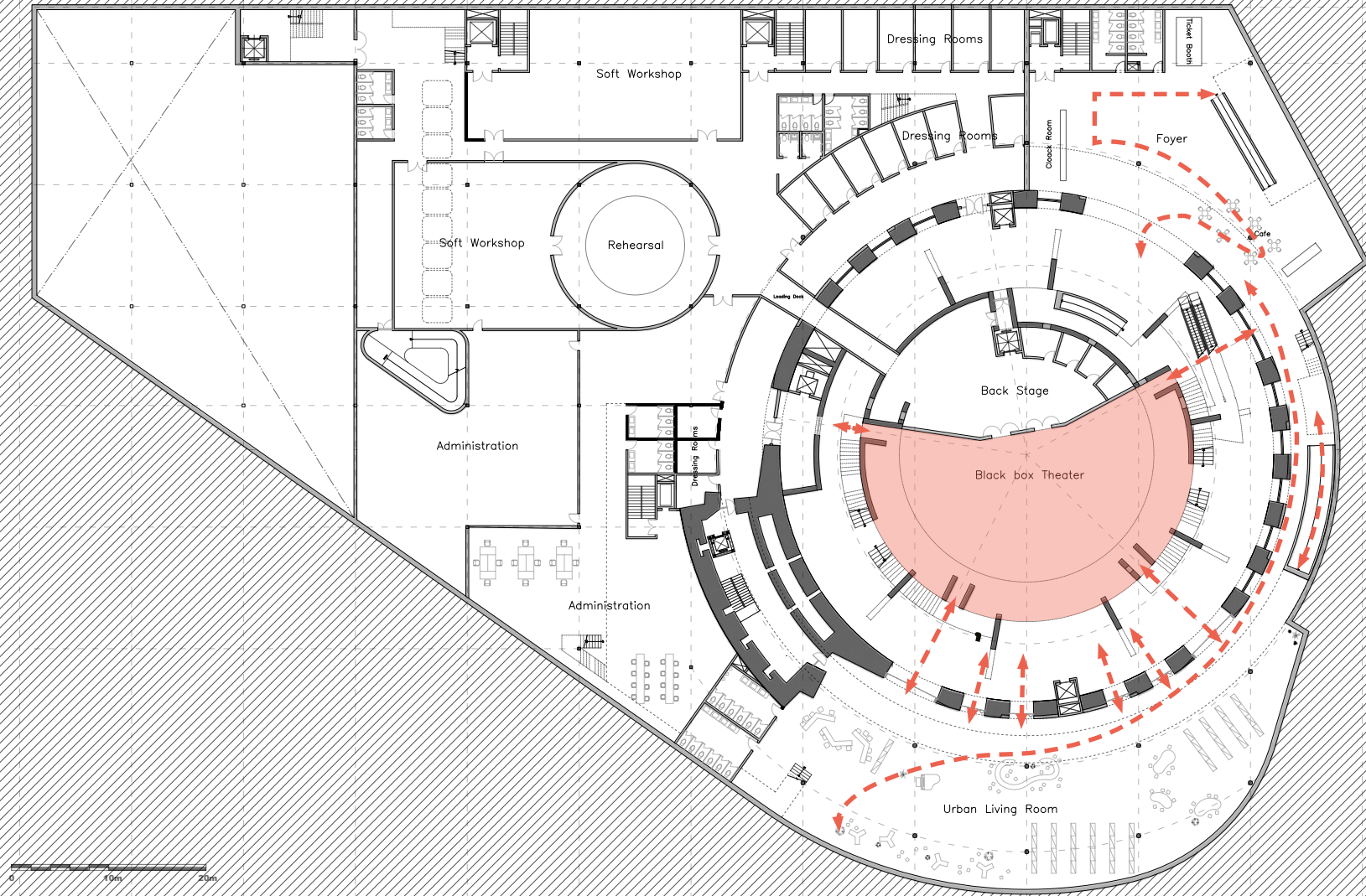

FIRST BASEMENT FLOOR PLAN

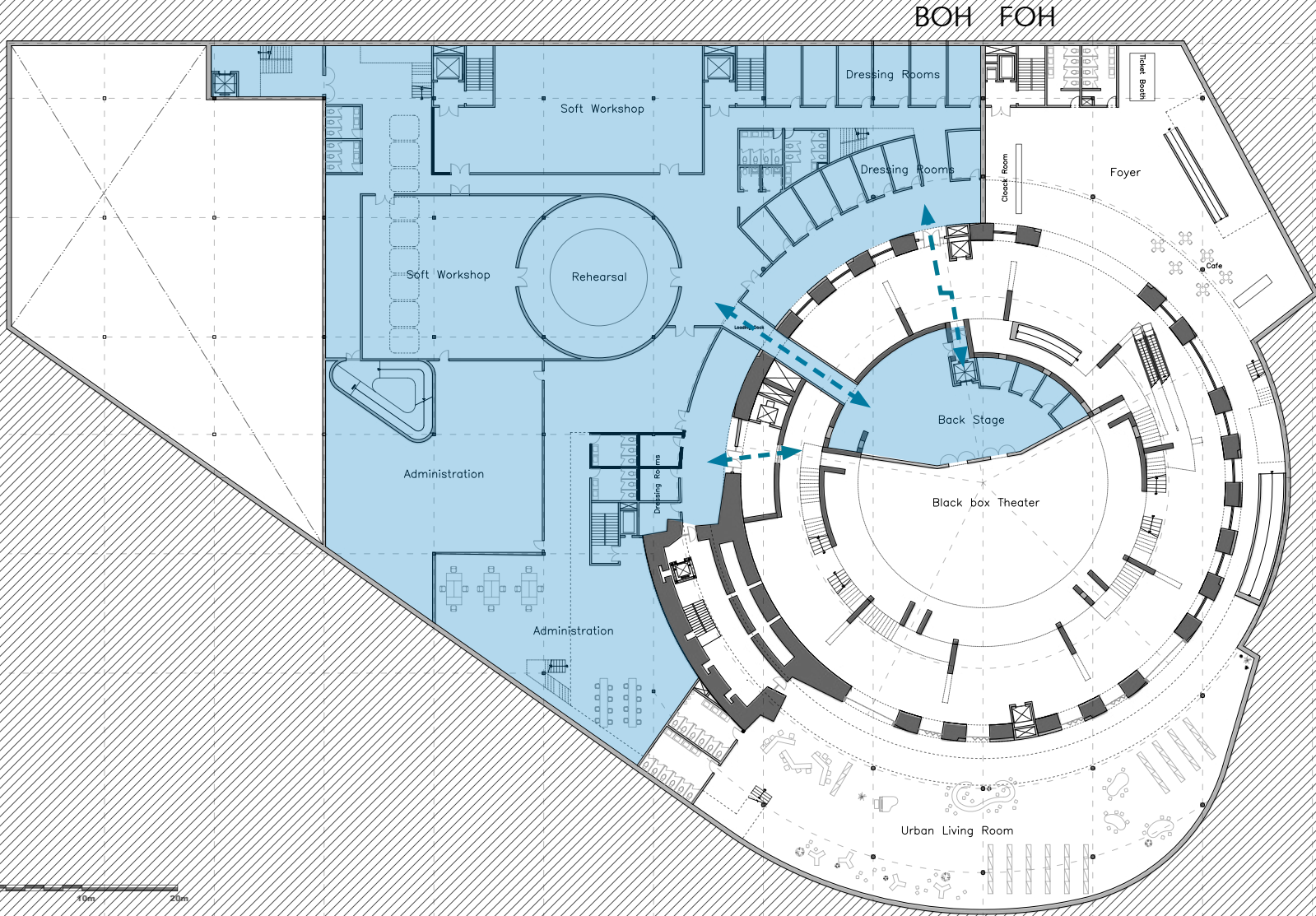

Implementation

GROUND FLOOR PLAN

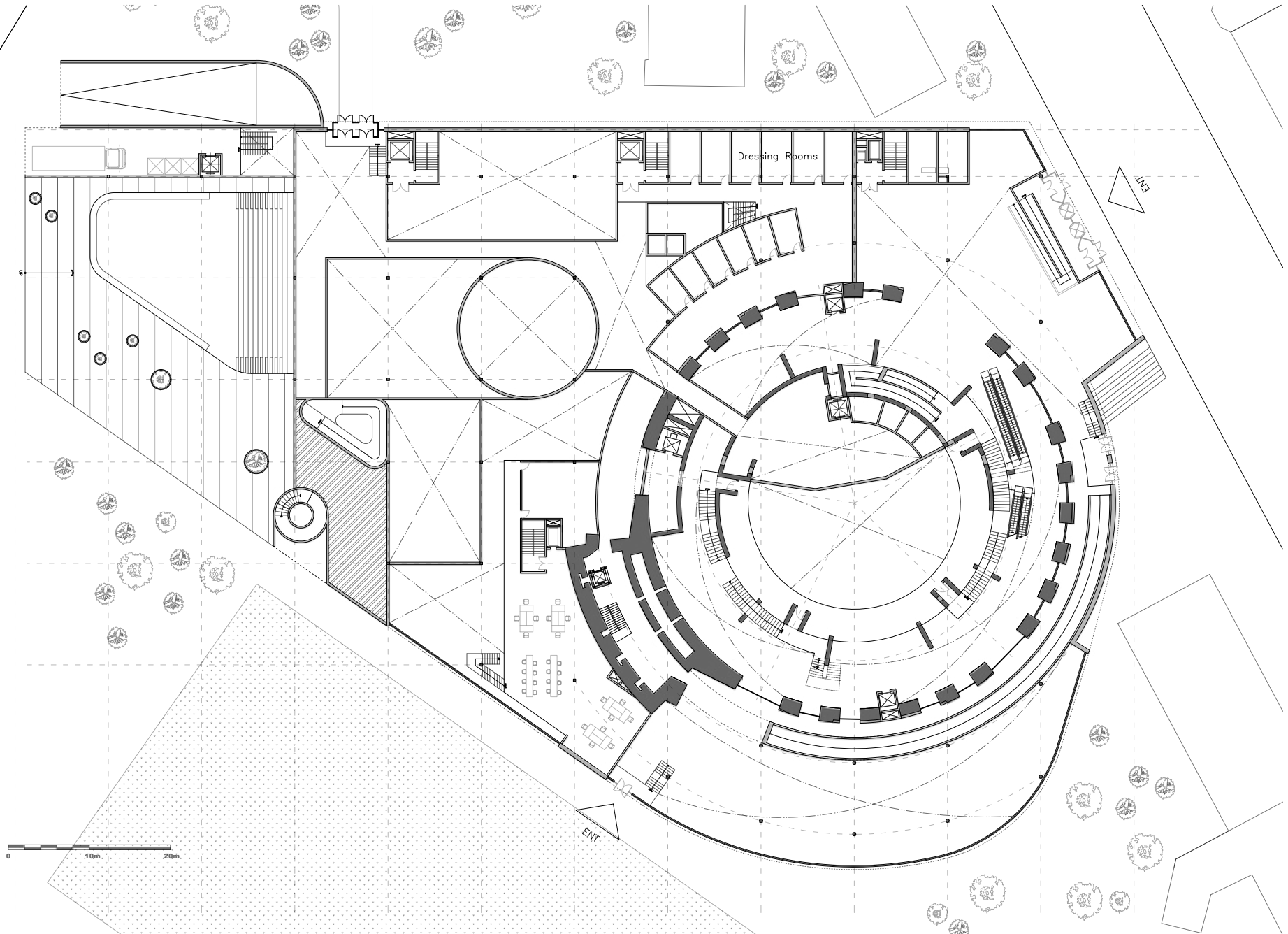

Implementation

GROUND FLOOR PLAN

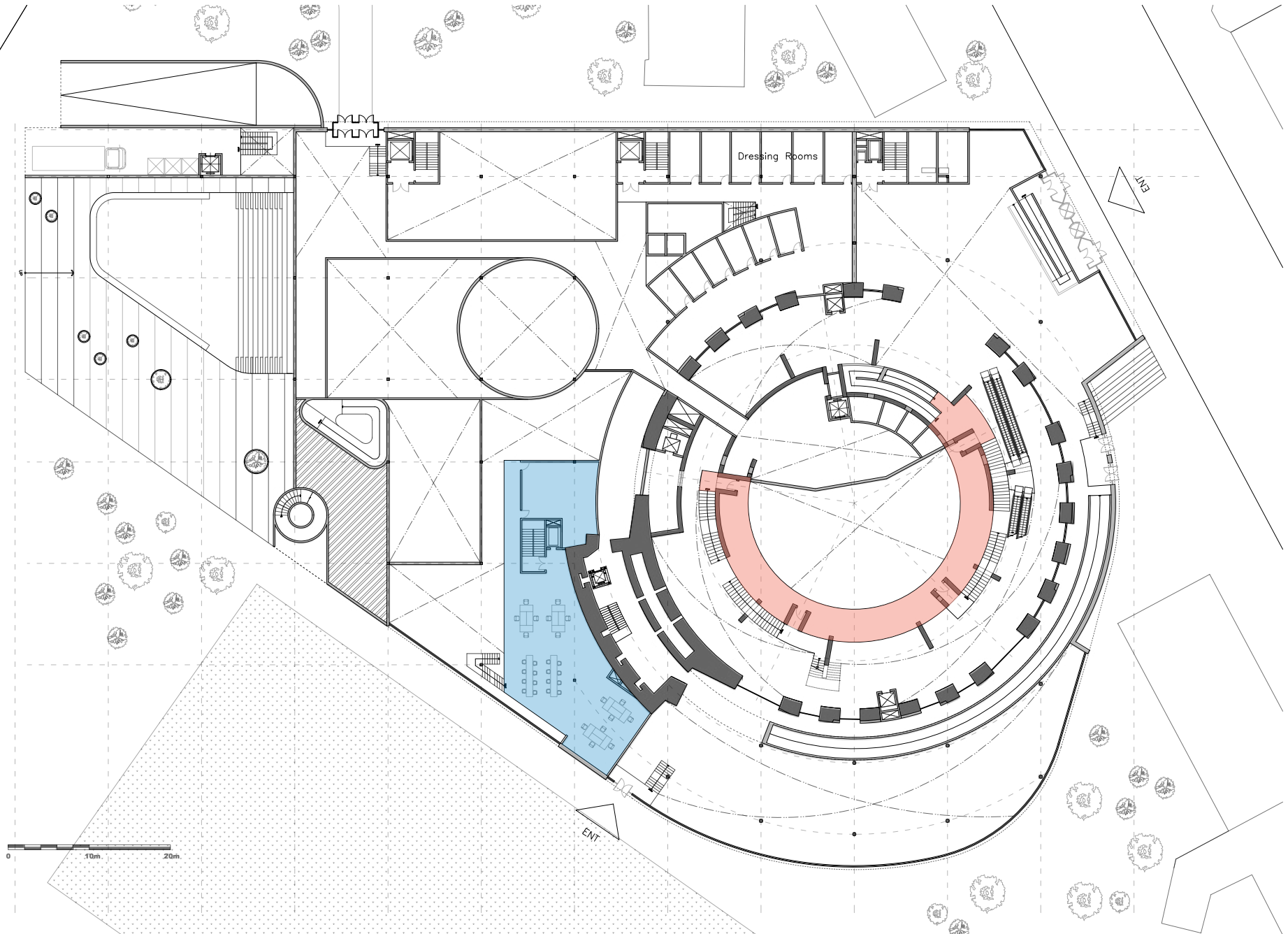

Implementation

FIRST FLOOR PLAN

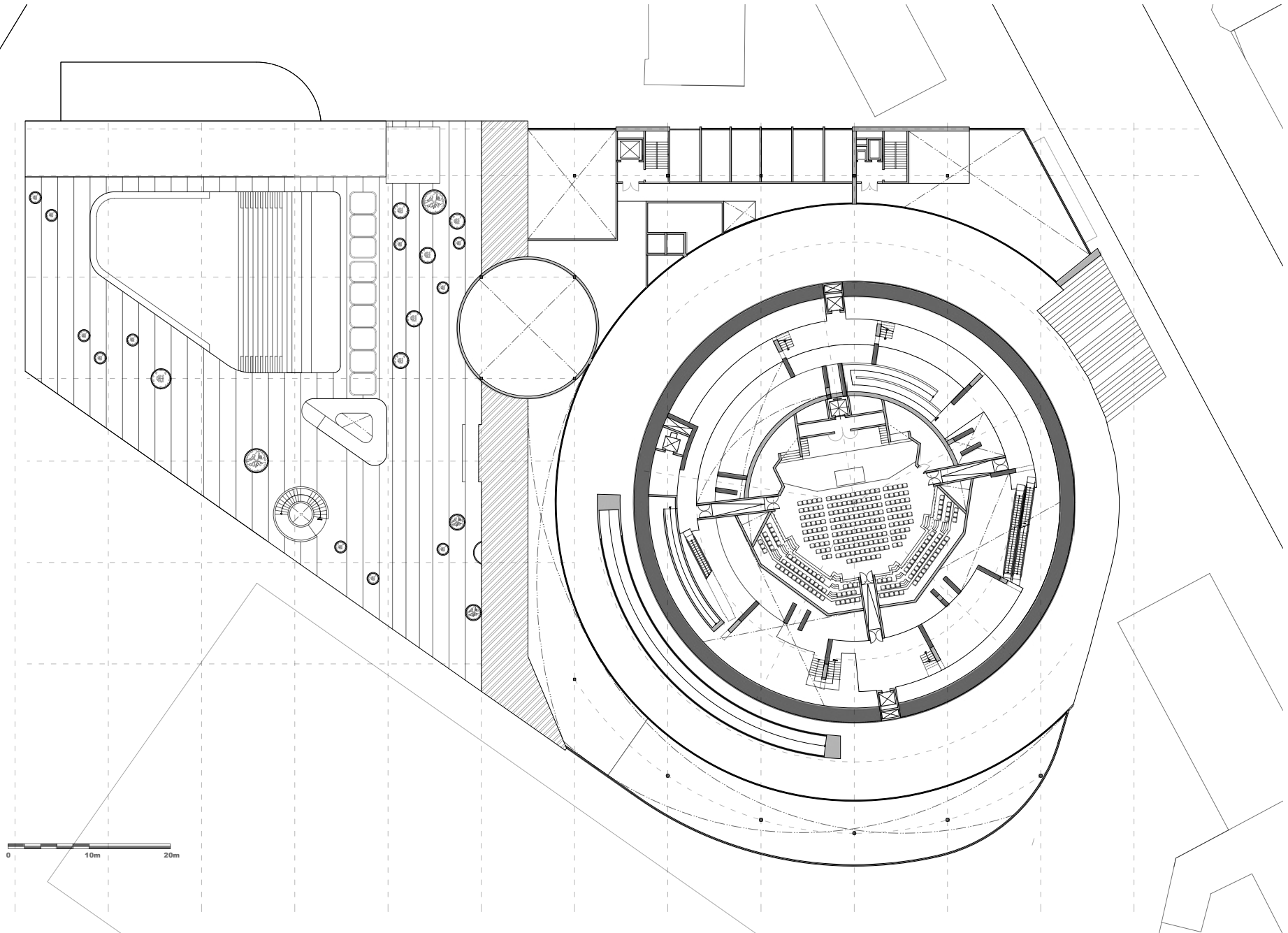

Implementation

FIRST FLOOR PLAN

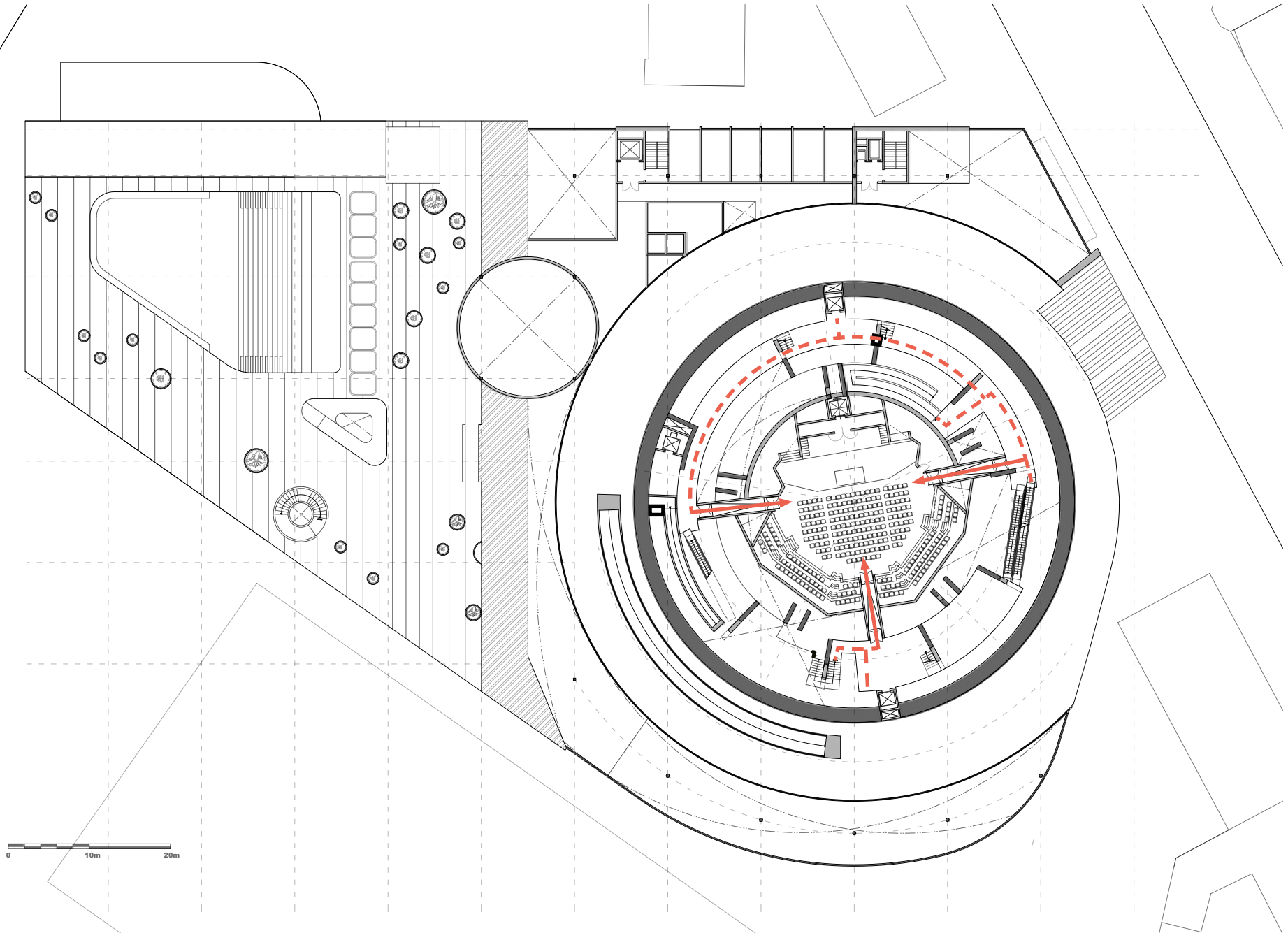

Implementation
SECOND FLOOR PLAN

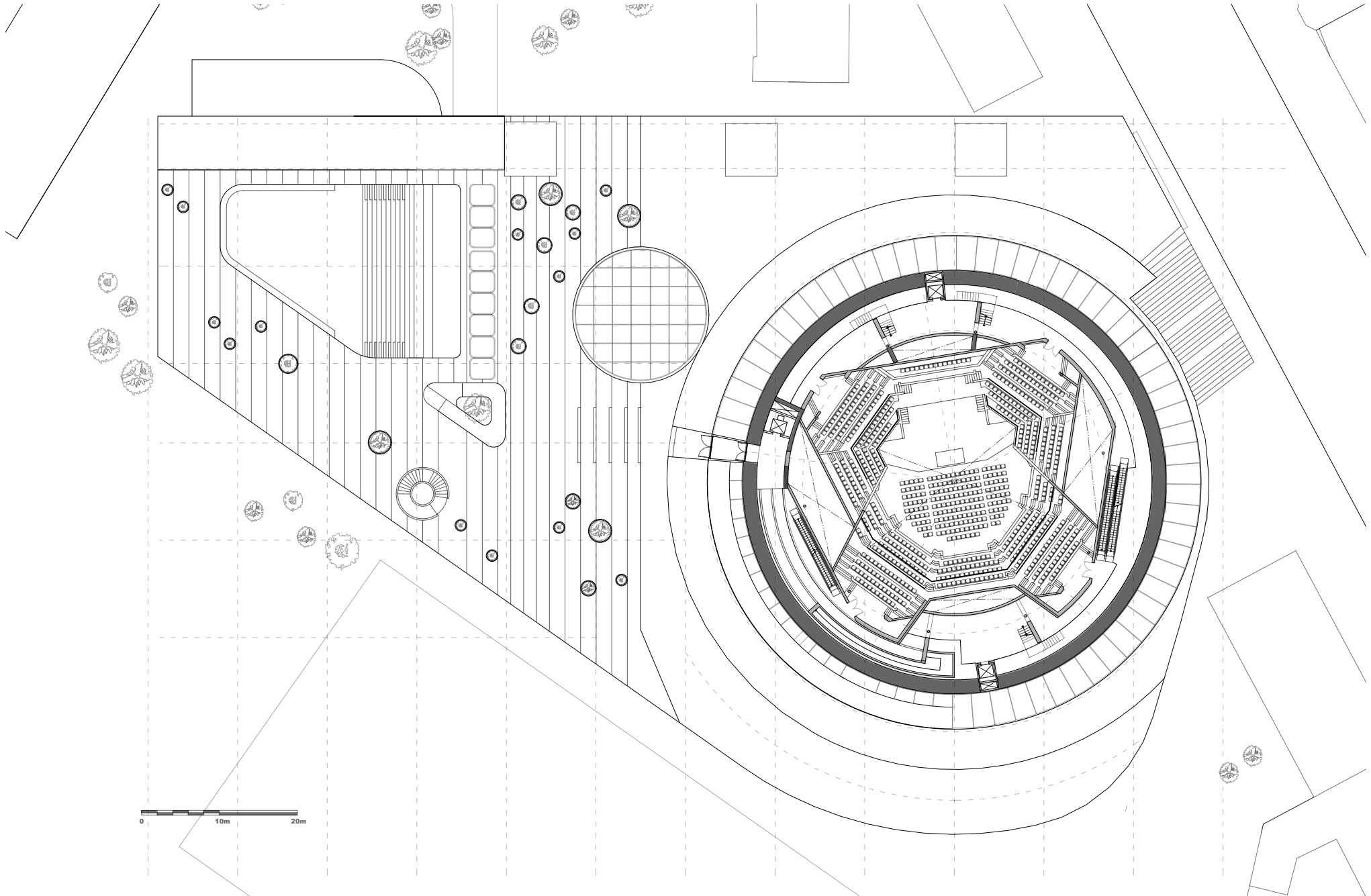

Implementation
SECOND FLOOR PLAN

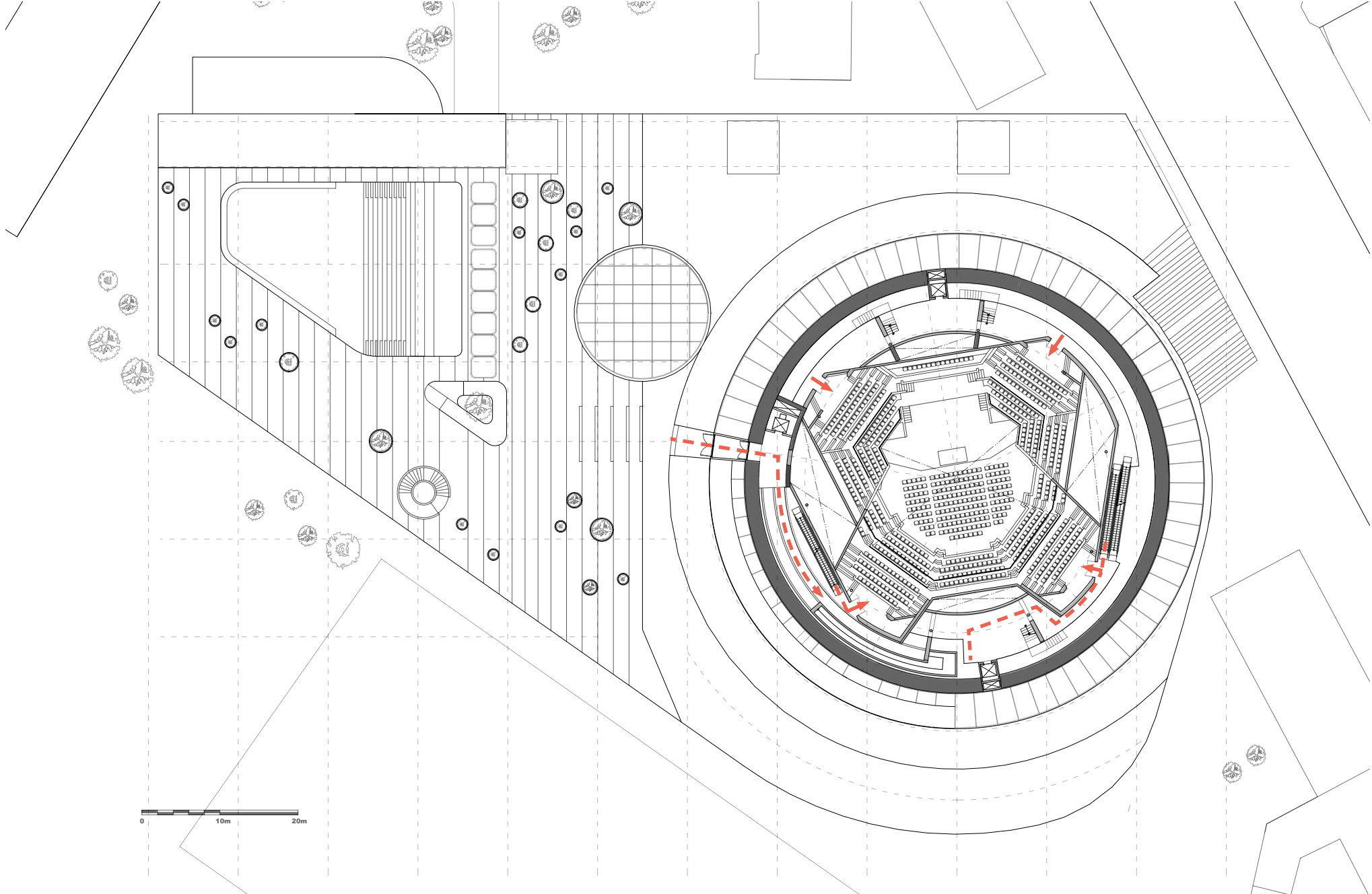

Implementation
THIRD FLOOR PLAN

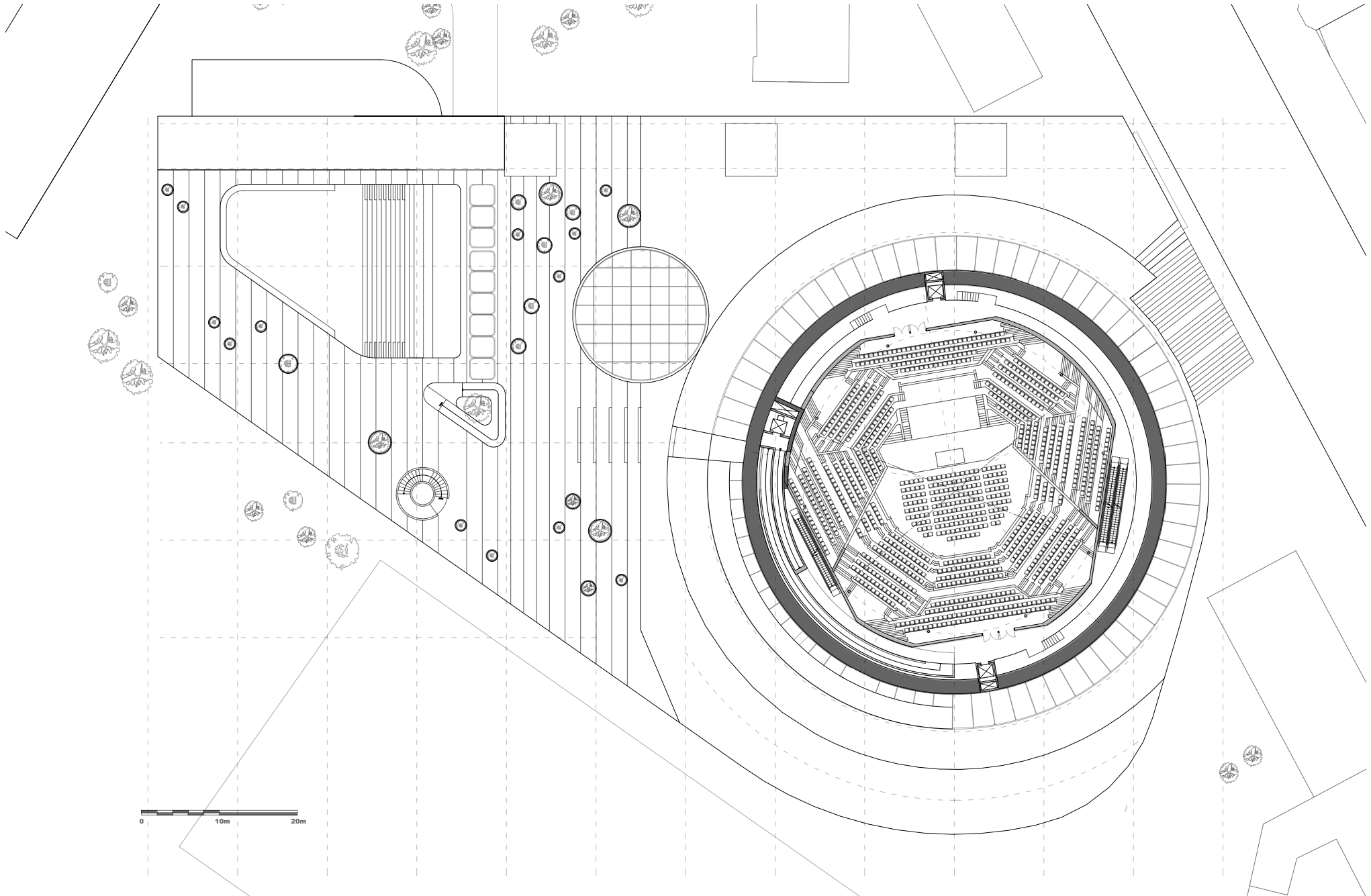

Implementation

THIRD FLOOR PLAN

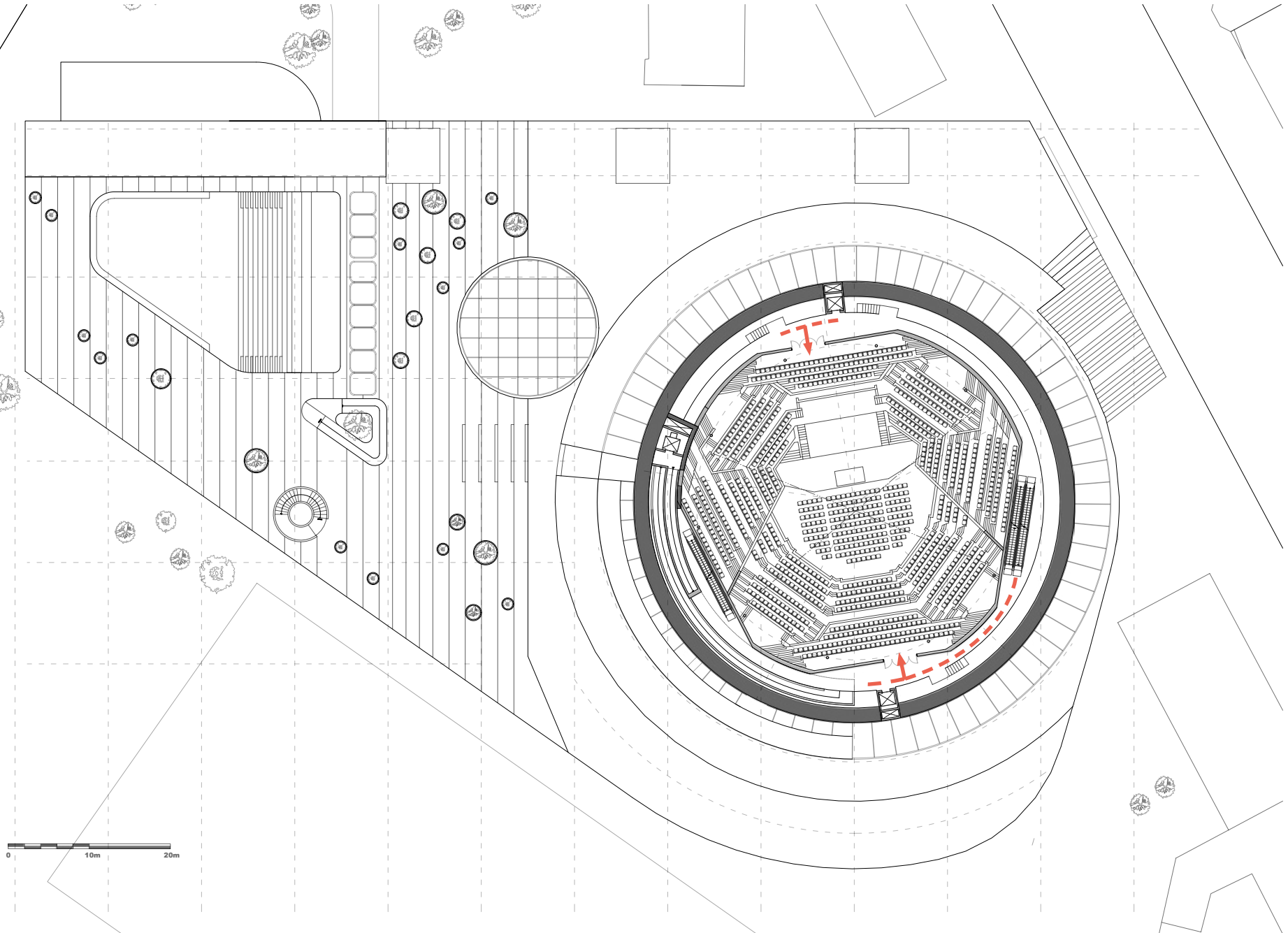

Implementation

CLASSICAL CONCERT HALL



Implementation

FOURTH FLOOR PLAN

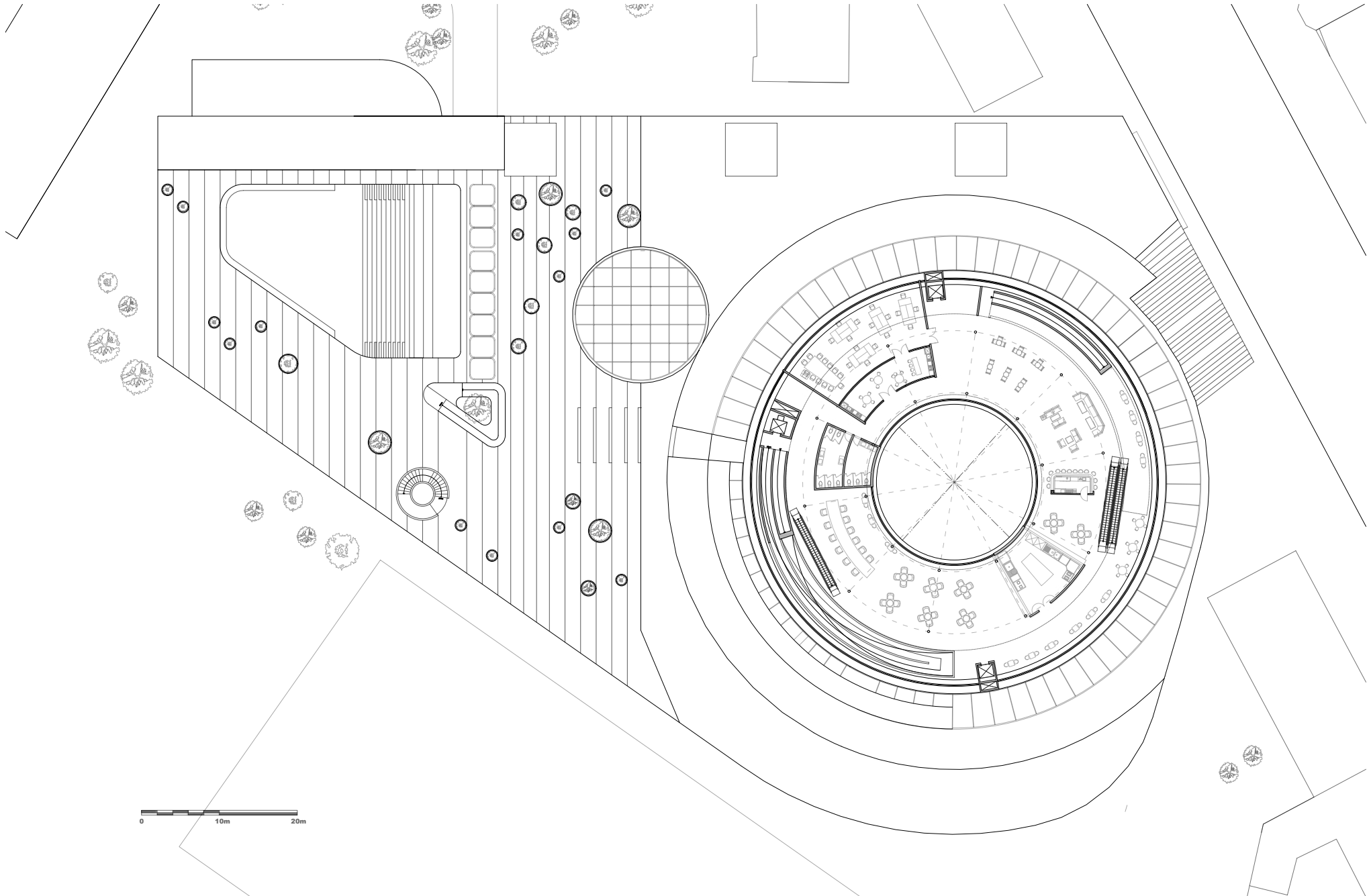

Implementation ROOFTOP



Implementation **ROOFTOP**



Implementation

ROOF FLOOR PLAN

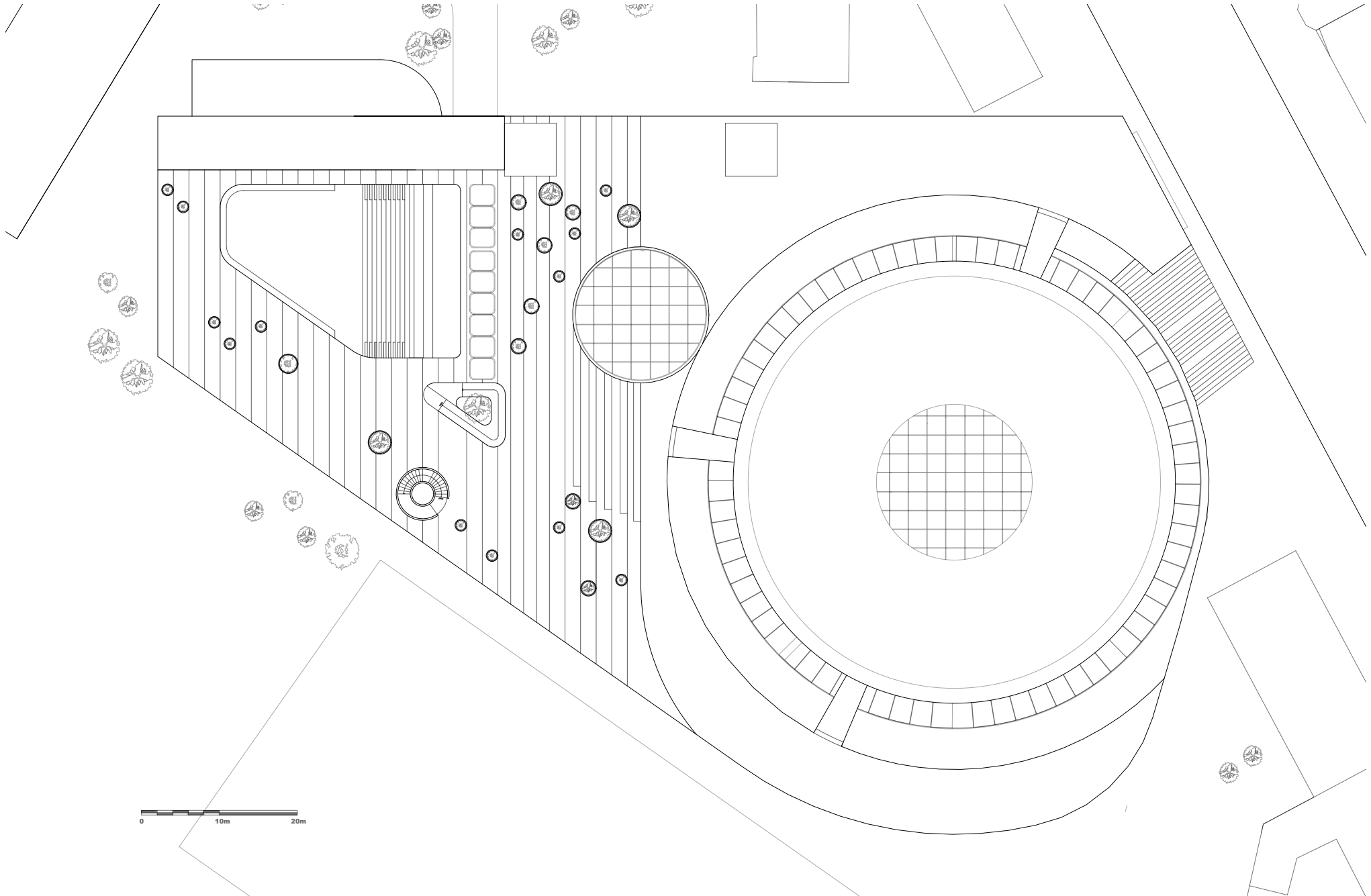

Implementation
KEY SPACE DRAWING

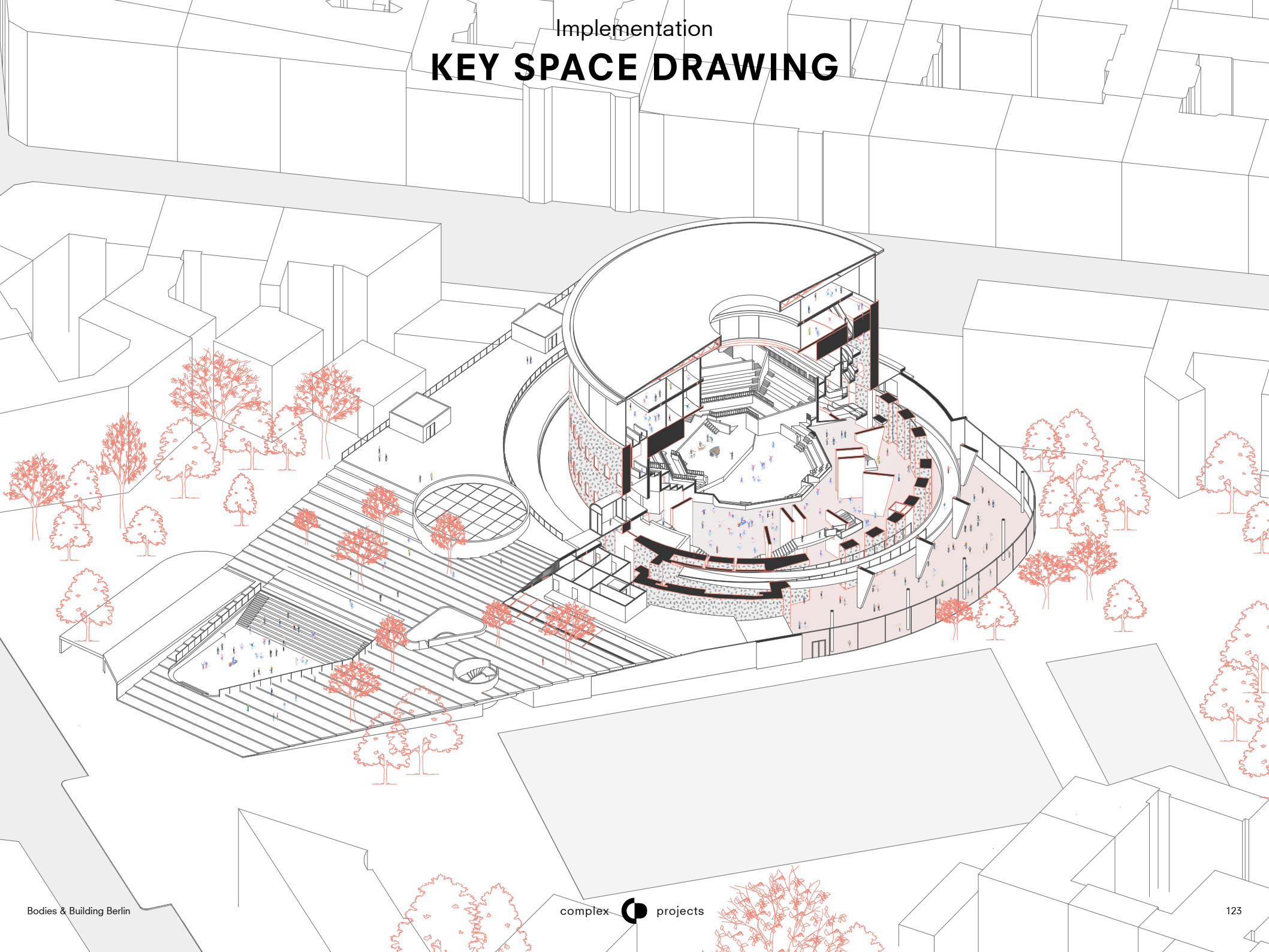

Implementation KEY SPACE DRAWING

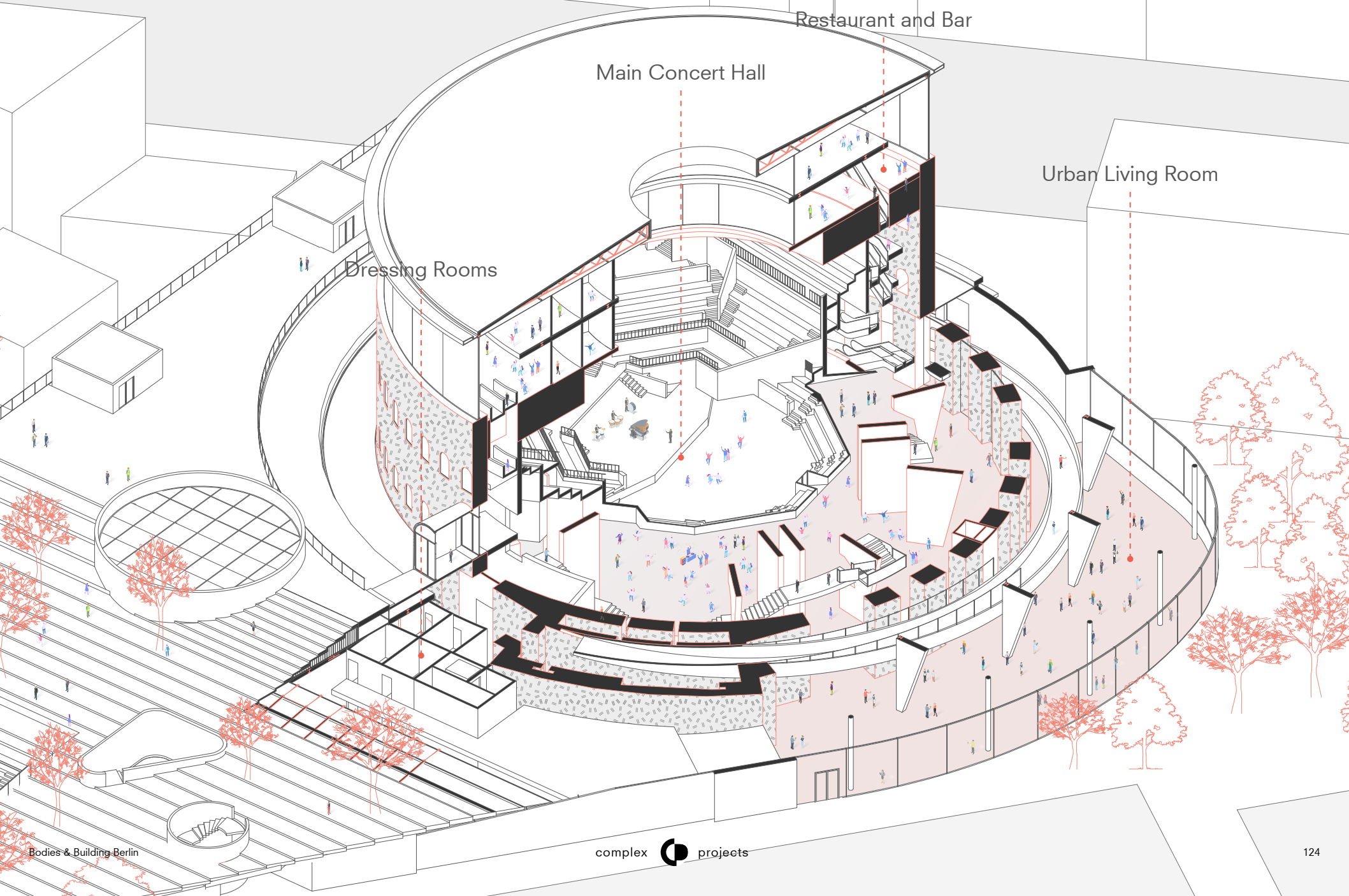

Implementation KEY SPACE DRAWING

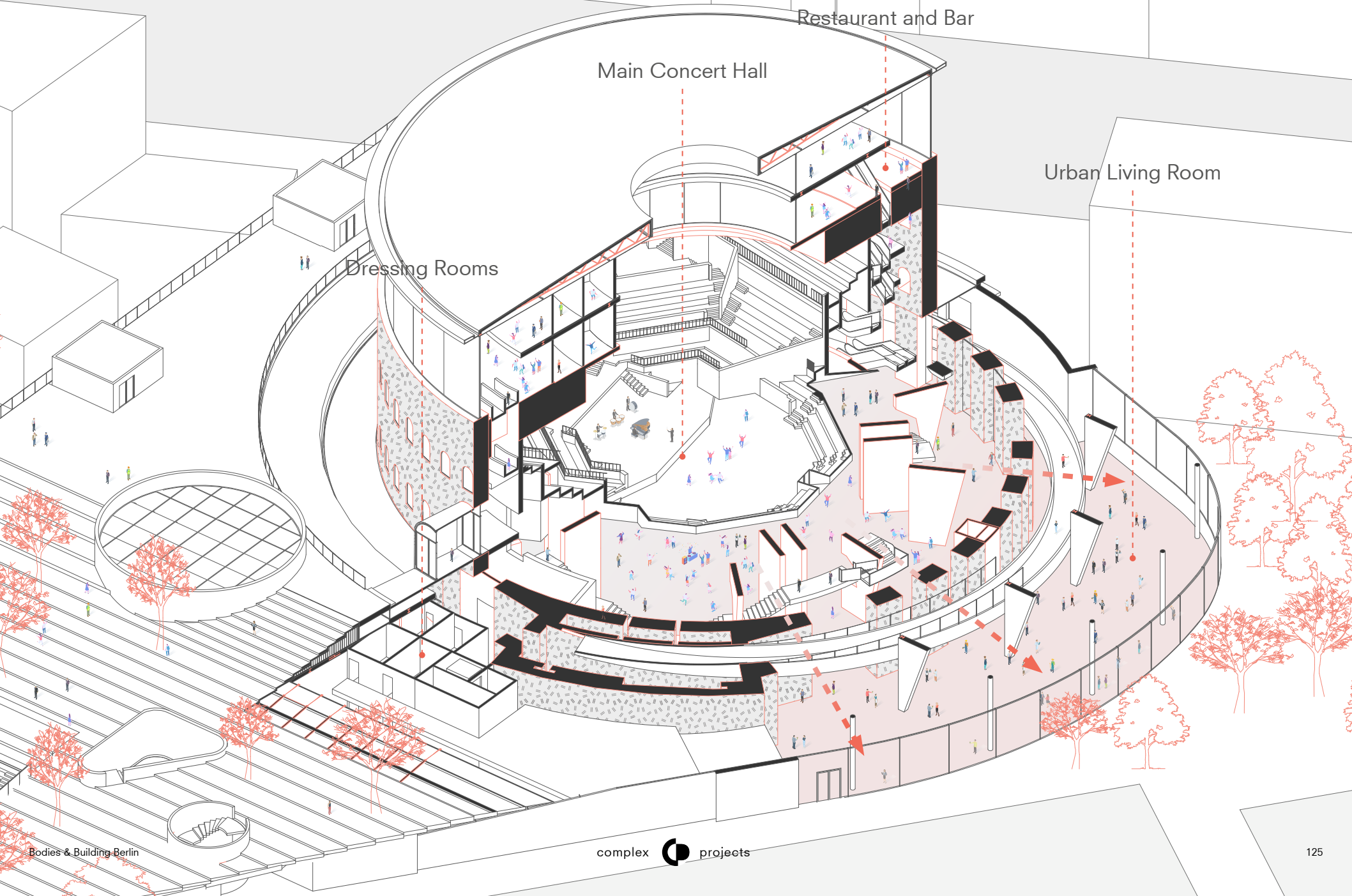

Implementation
PERSPECTIVE SECTION

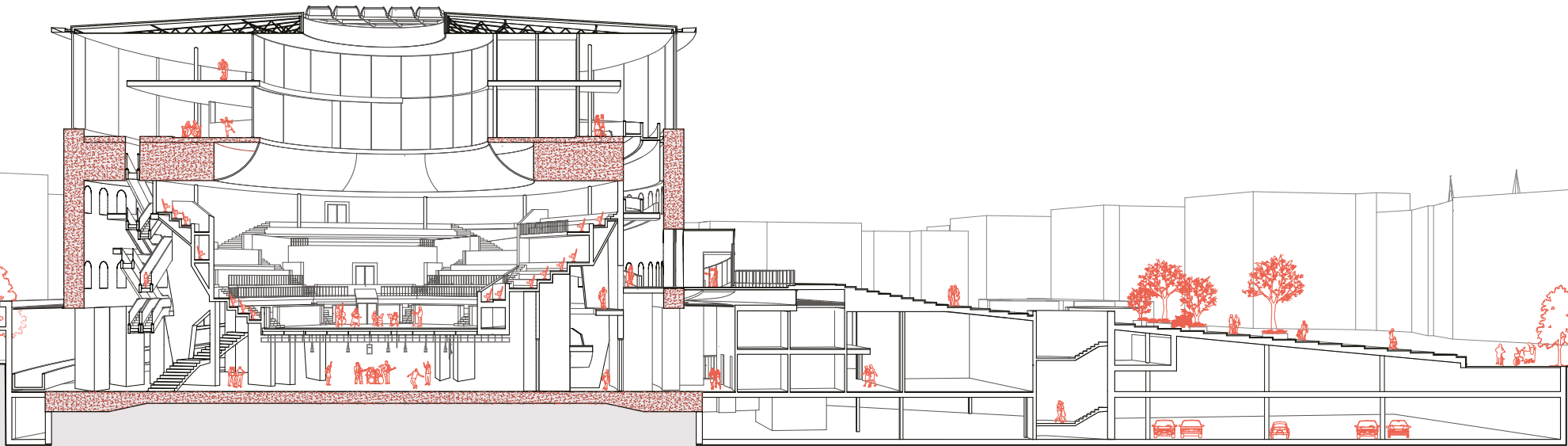
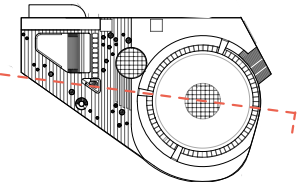

Implementation
PERSPECTIVE SECTION

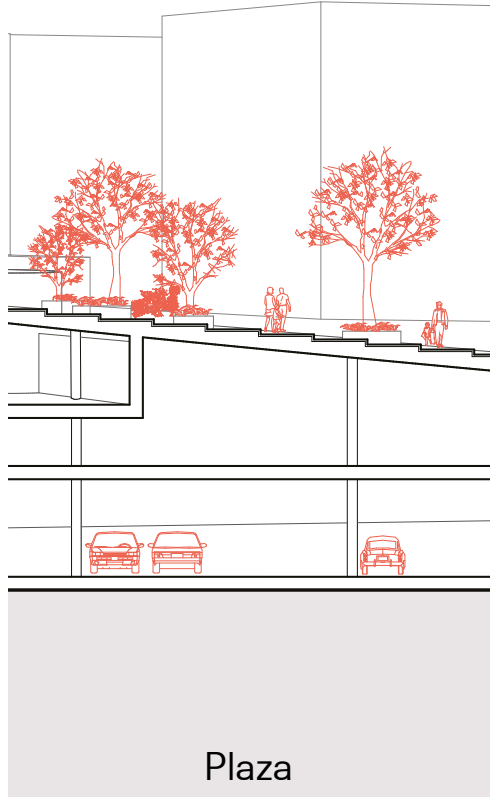
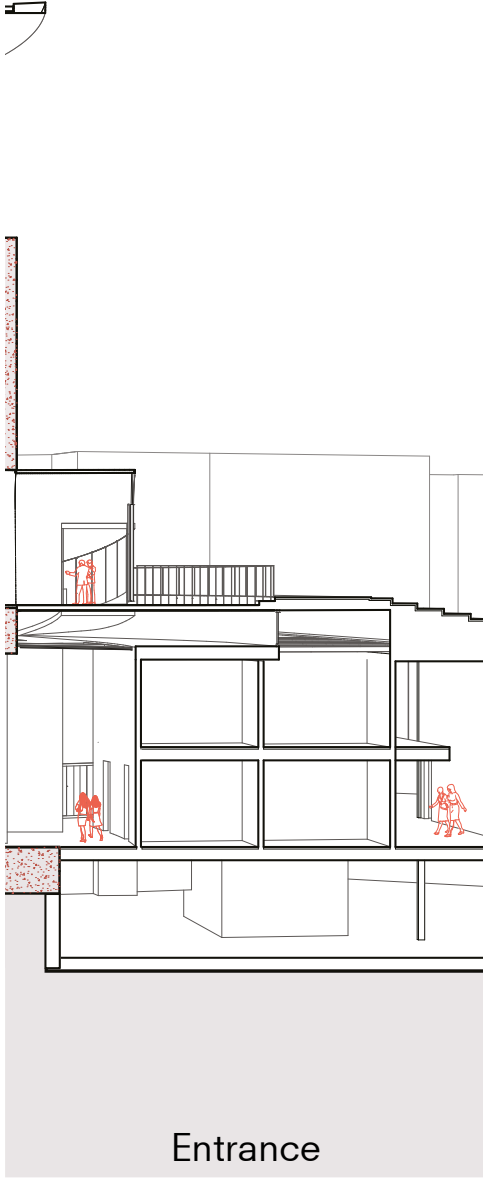
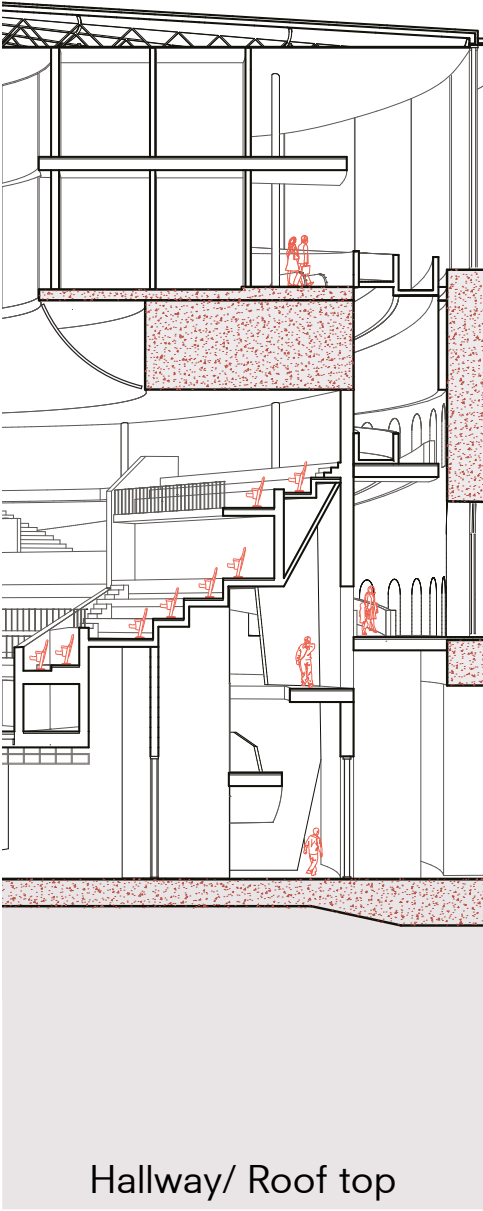
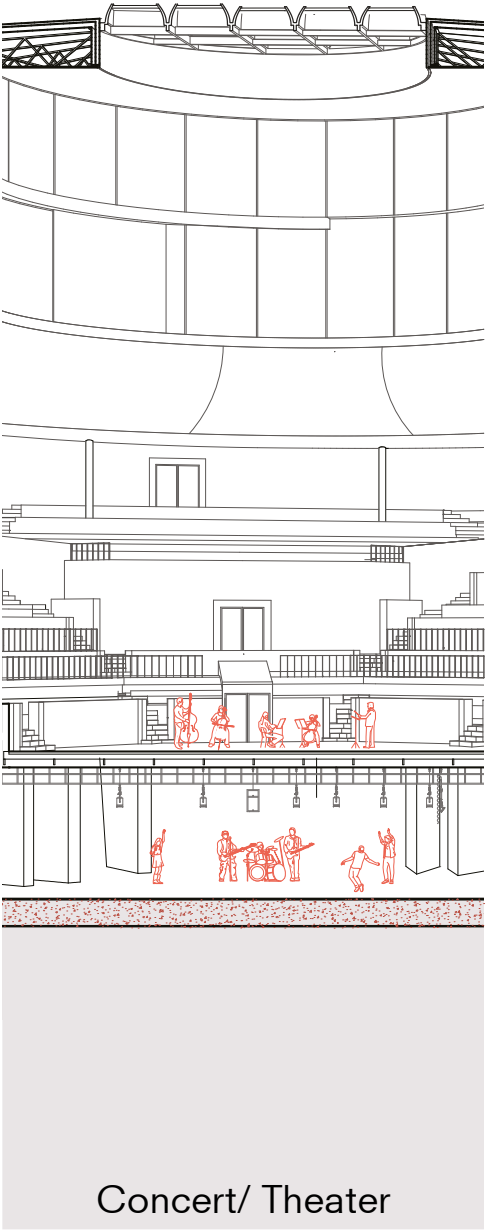

DEVELOPMENT

Development FACADE MATERIAL

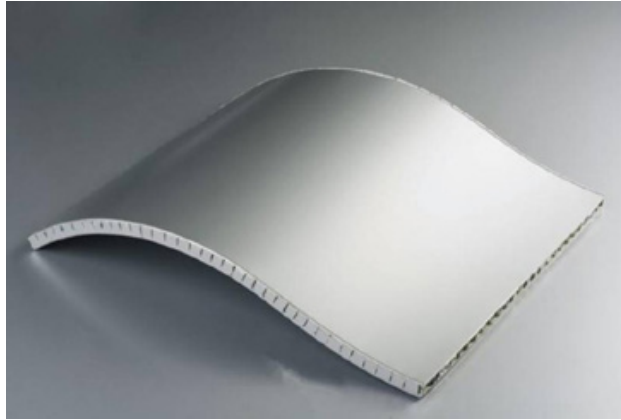

Curved Aluminum Honeycomb Panel

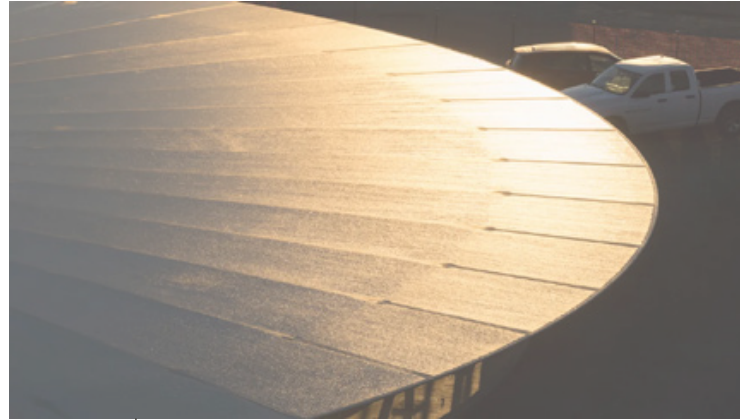

Carbon Fiber Roof



Curved Glass Wall



Development

FICHTE COMMEMORATIVE PLAZA

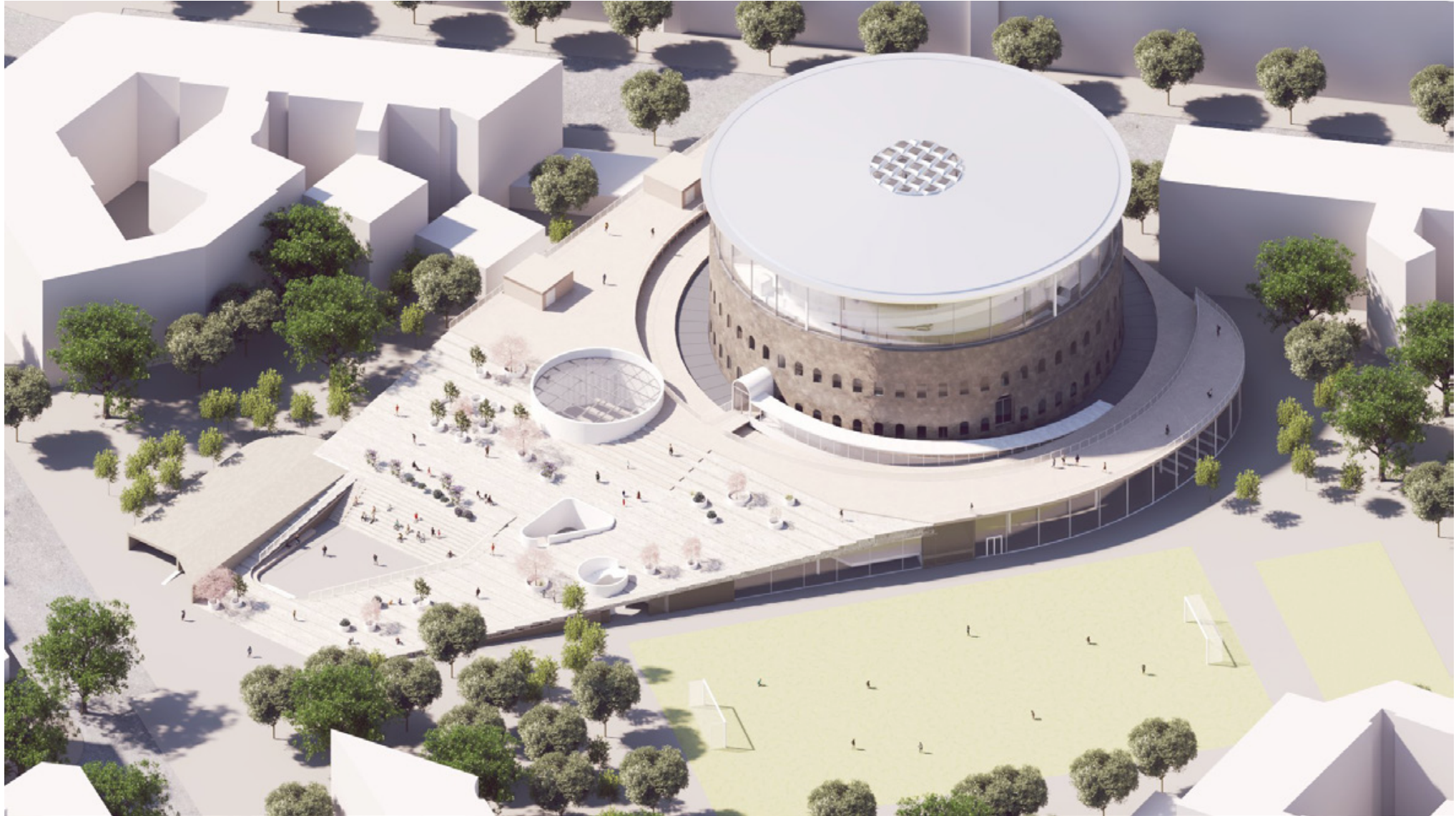

FICHTE COMMEMORATIVE PLAZA

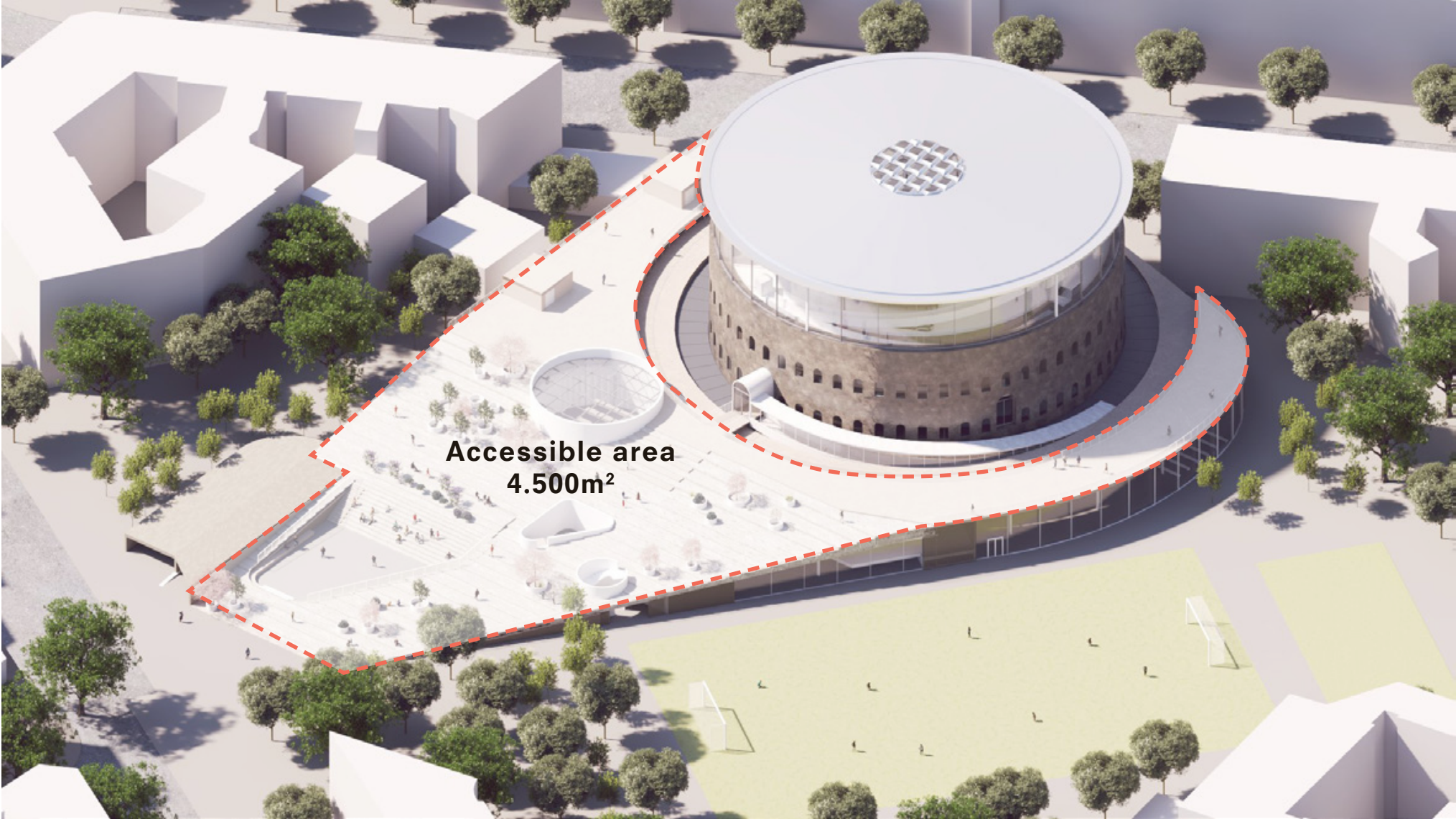

FICHTE COMMEMORATIVE PLAZA

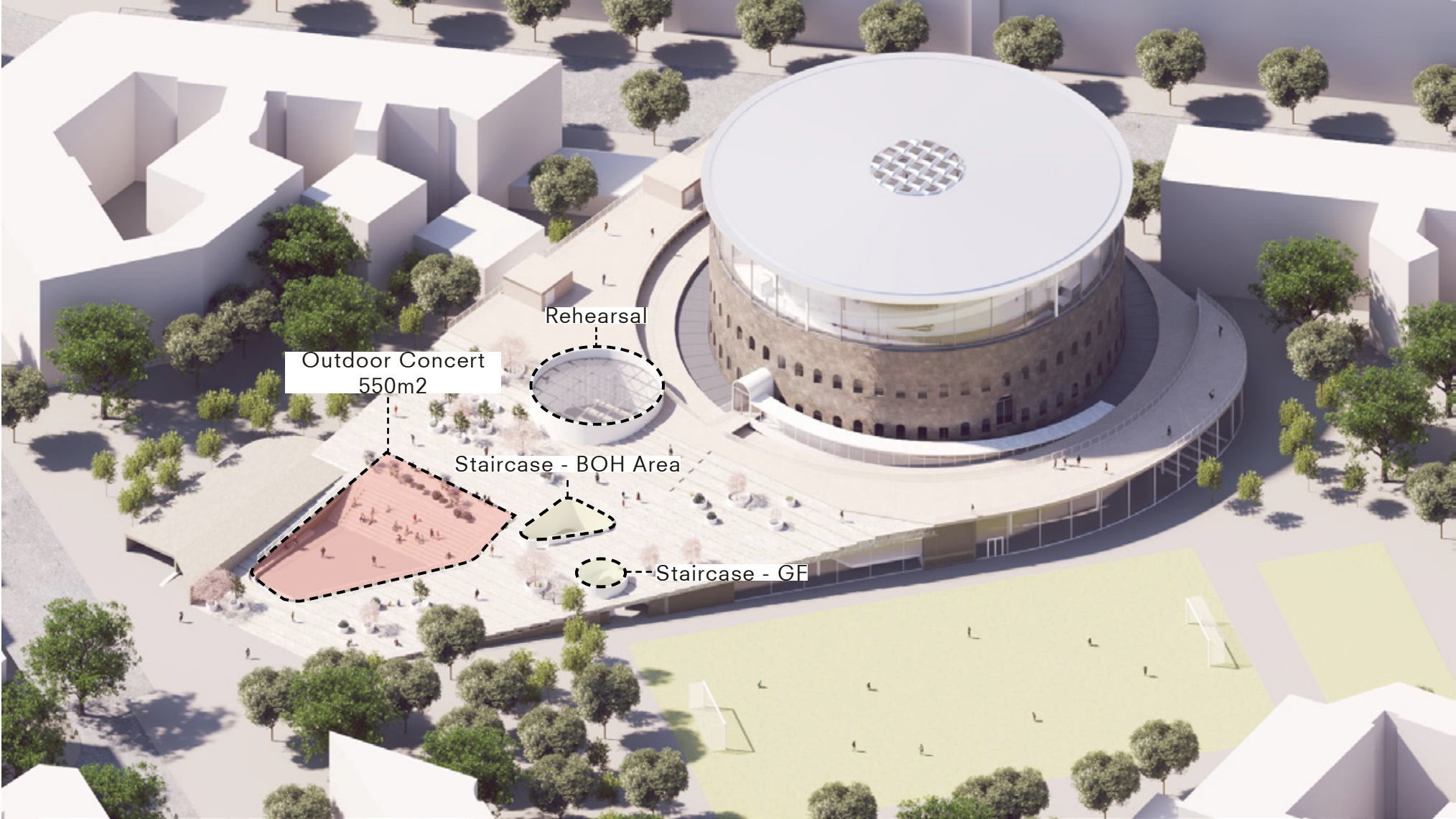

MATERIAL REUSE FROM FICHTEBUNKER

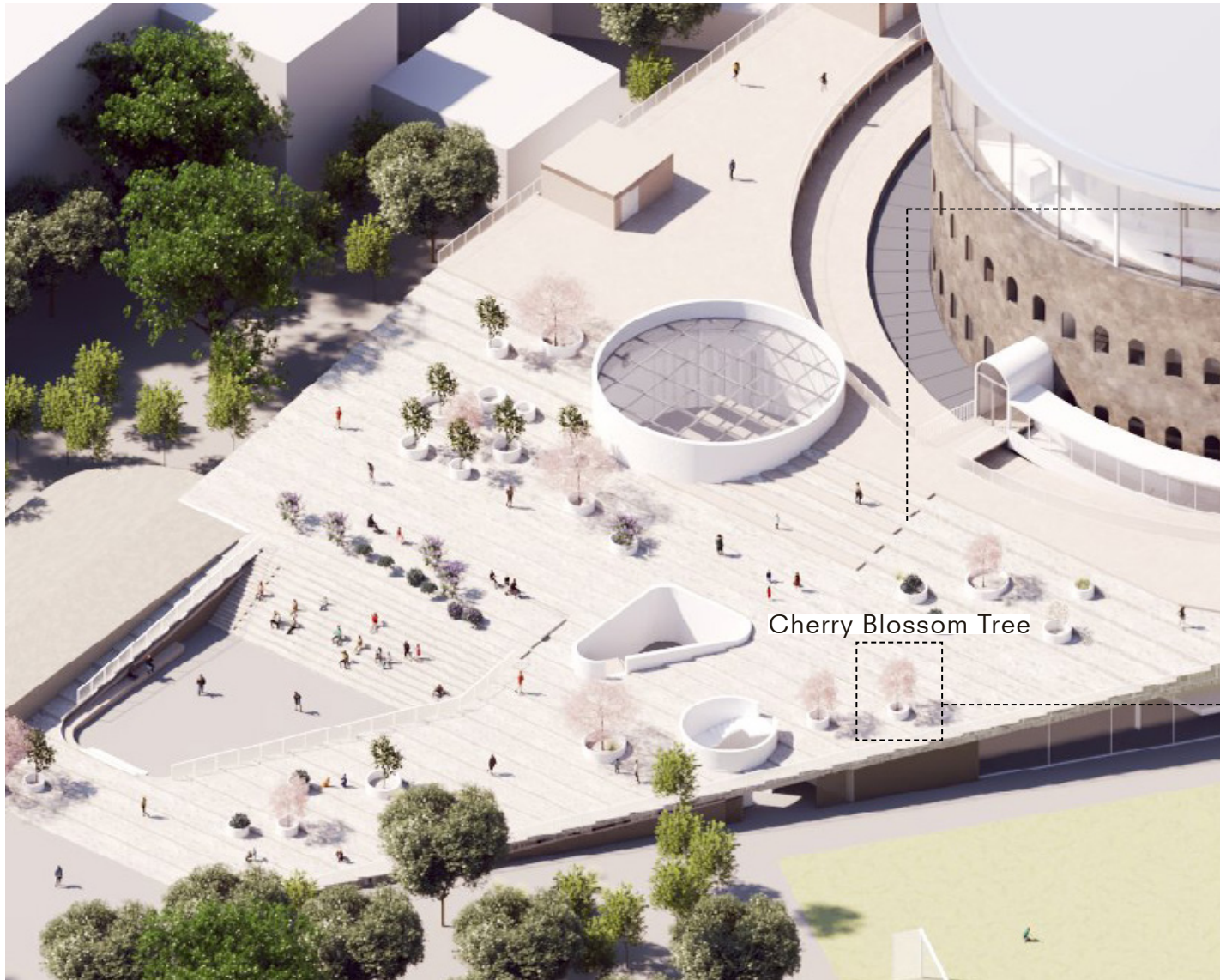

Brick from Fichte Bunker



Plaza Flooring



Concrete Waste



Sand for Plant Pots on Plaza

Development
SECTION 1 : 200

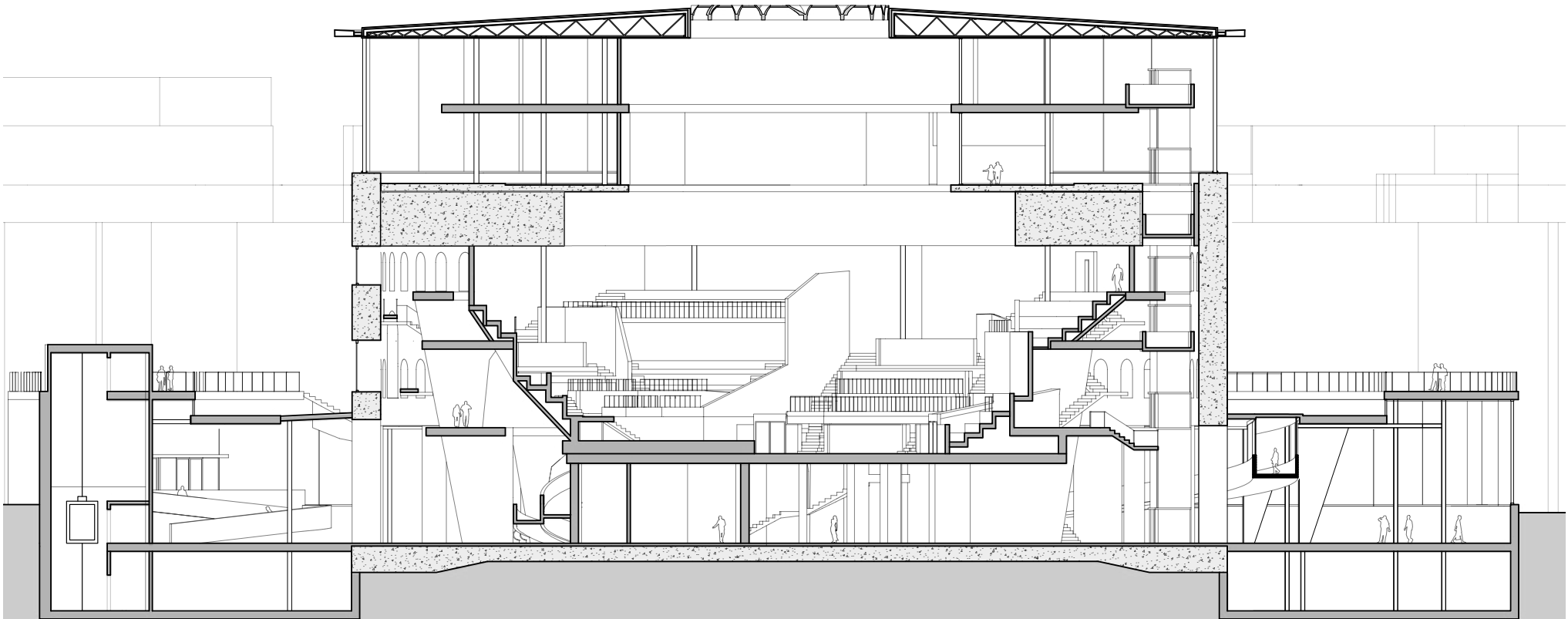
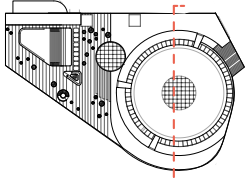

Development
SECTION 1 : 200

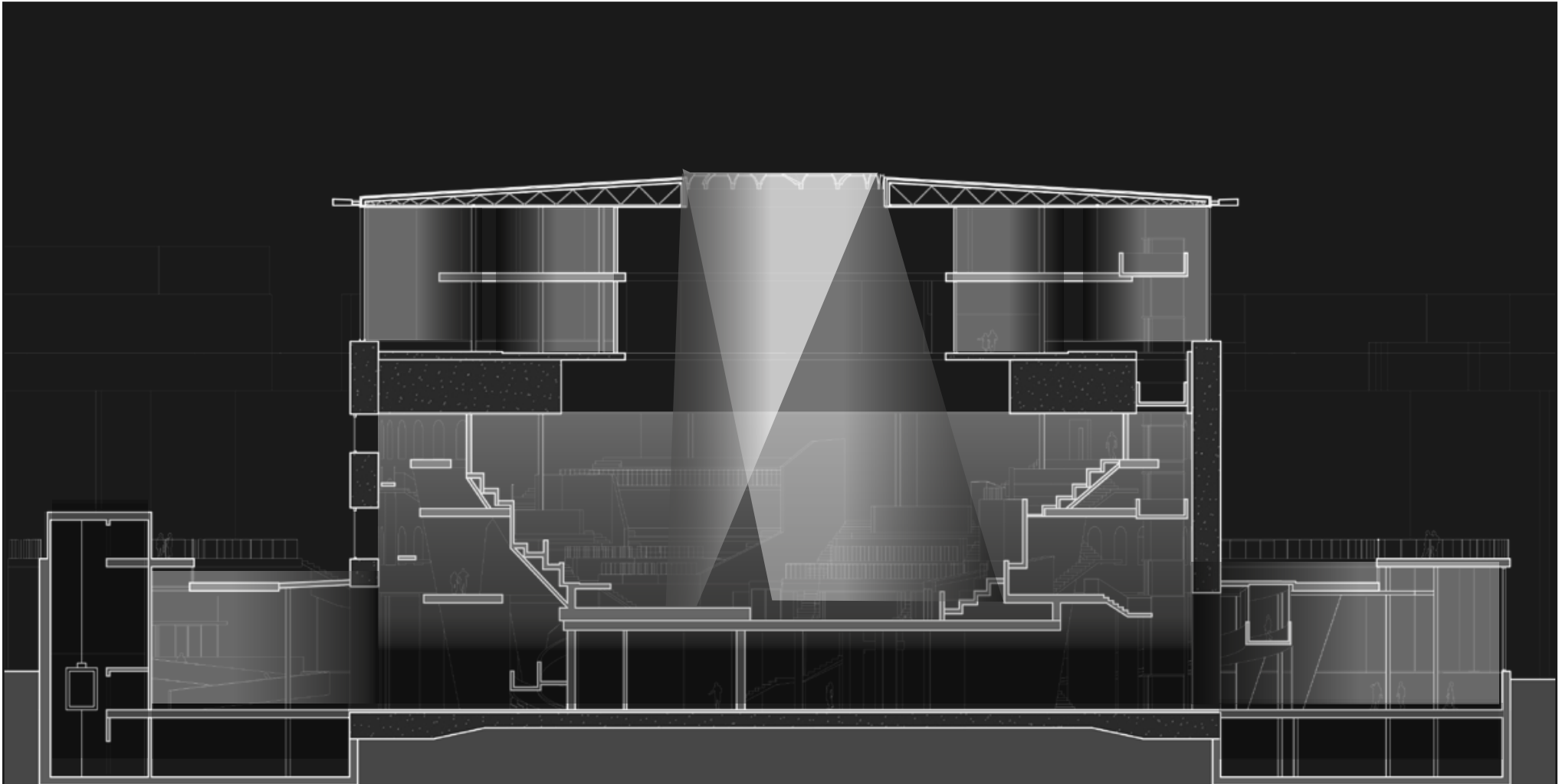
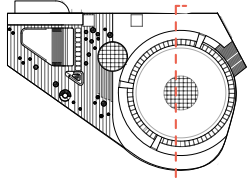

Contrast of Light and Shadow

Development
INTERIOR FRAGMENT

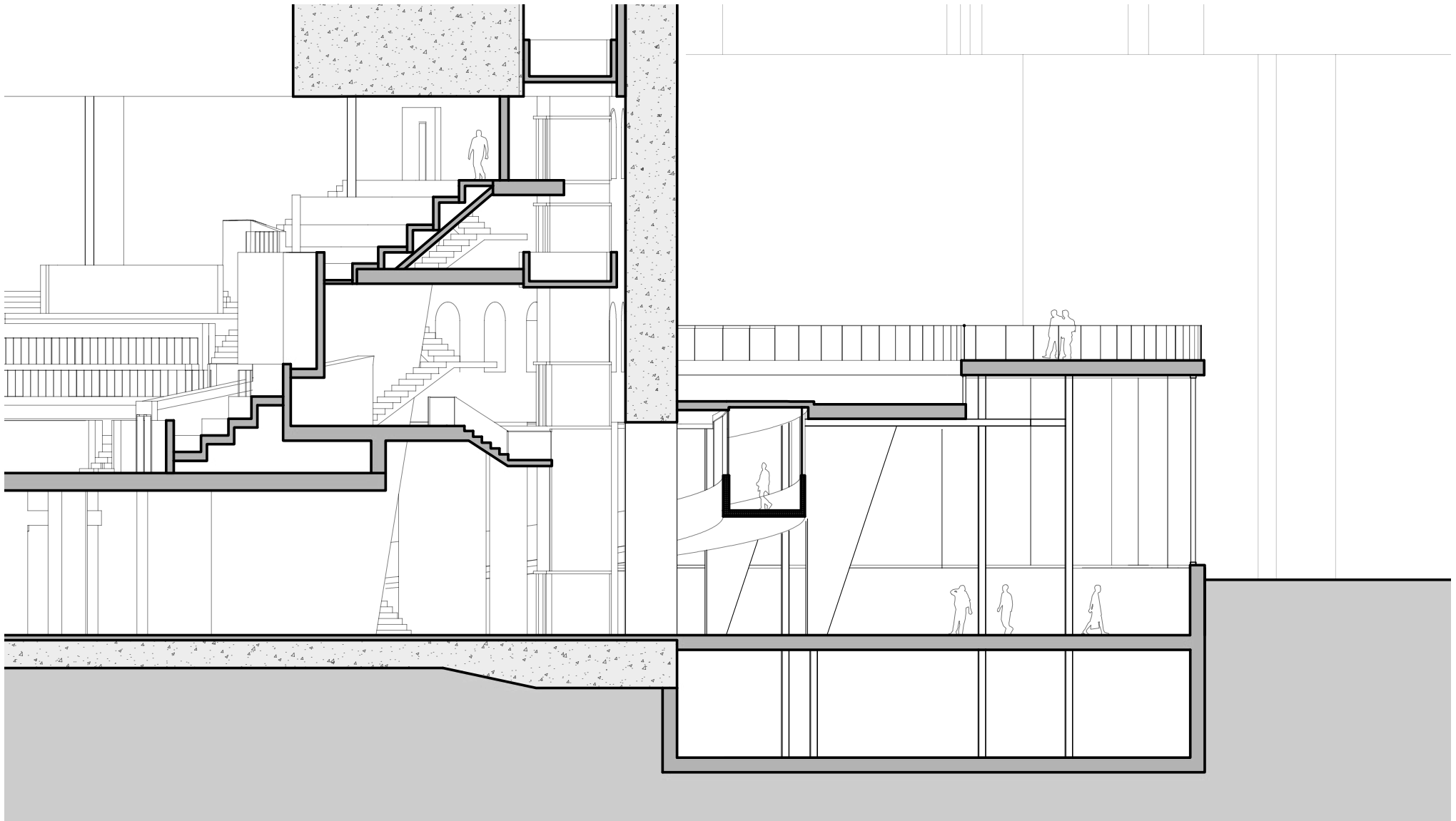

Architectural element and transition of spaces

Development
INTERIOR FRAGMENT

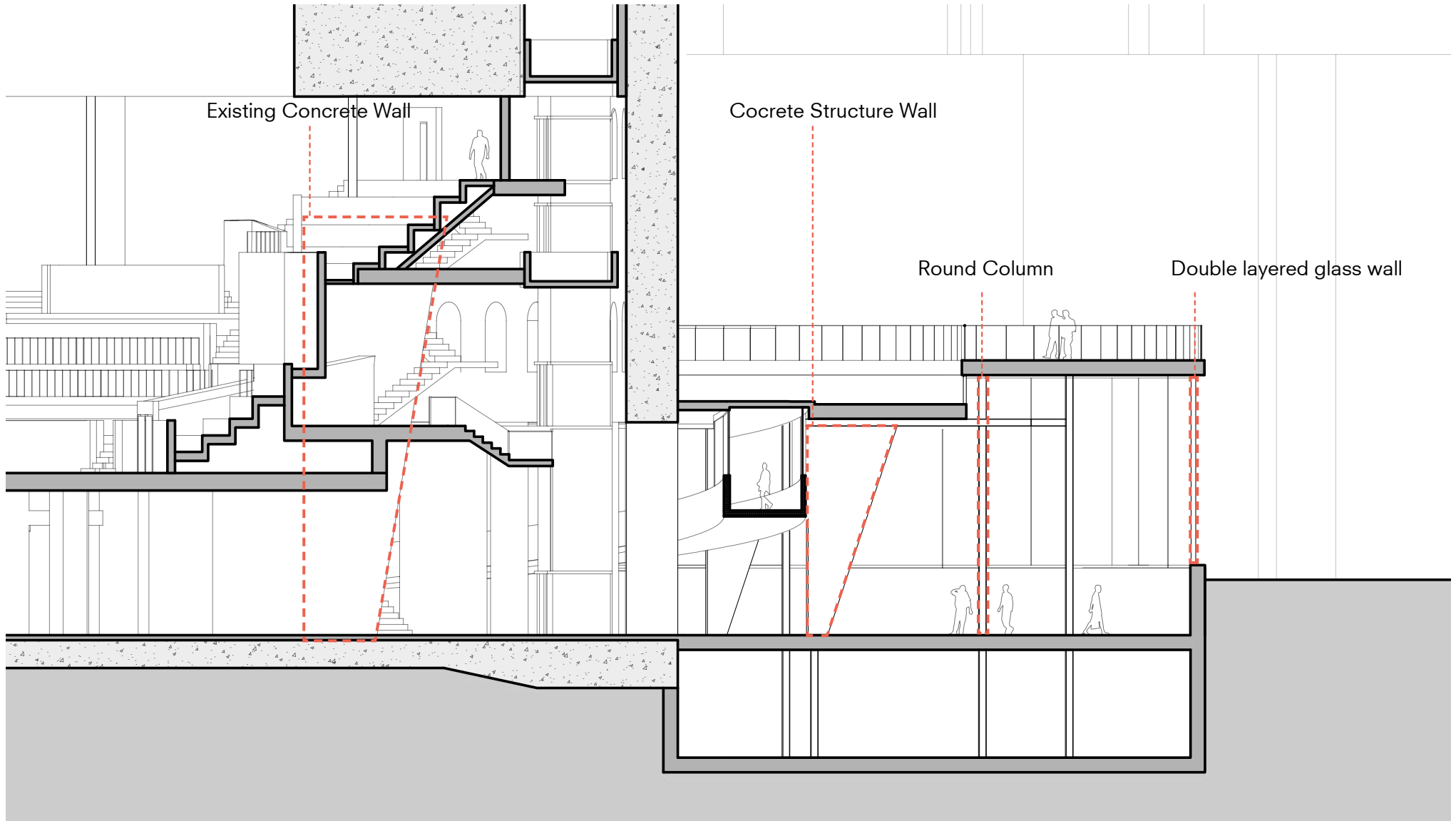

Architectural element and transition of spaces

IMPRESSION PLAZA AND FACADE



1 Plaza Access

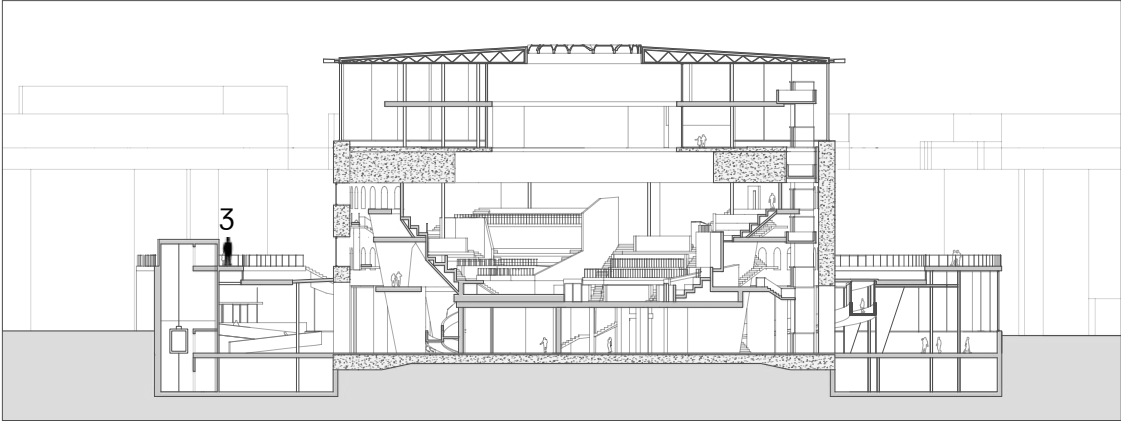

2 East Facade



3 Plaza with Bunker

IMPRESSION HALLWAY AND FOYER



1 Foyer

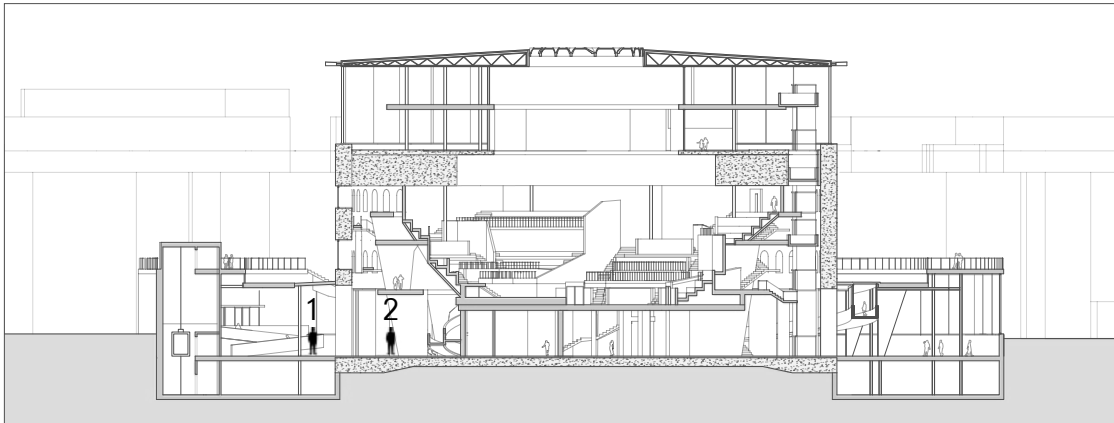

2 Hallway

IMPRESSION CONCERT HALL AND ROOFTOP



1 Classical Concert Hall

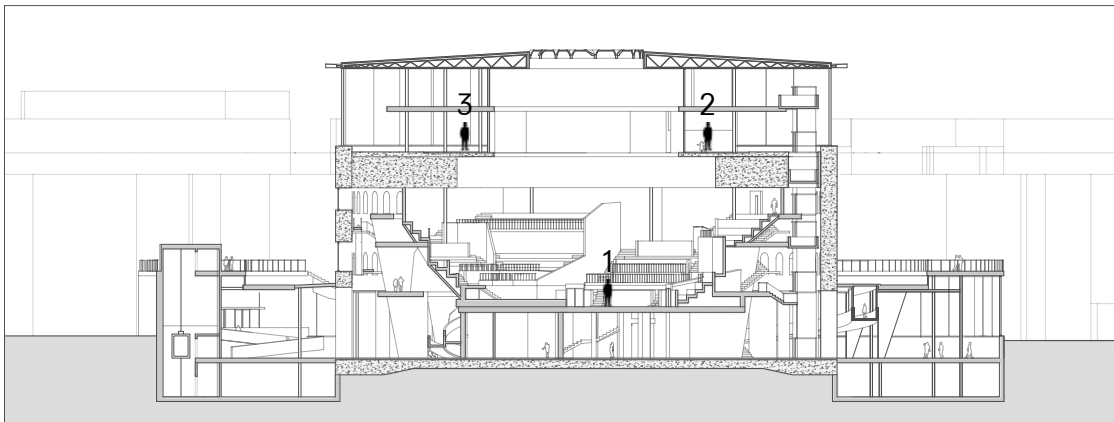

2 Rooftop 1



2 Rooftop 2

Development
STRUCTURE

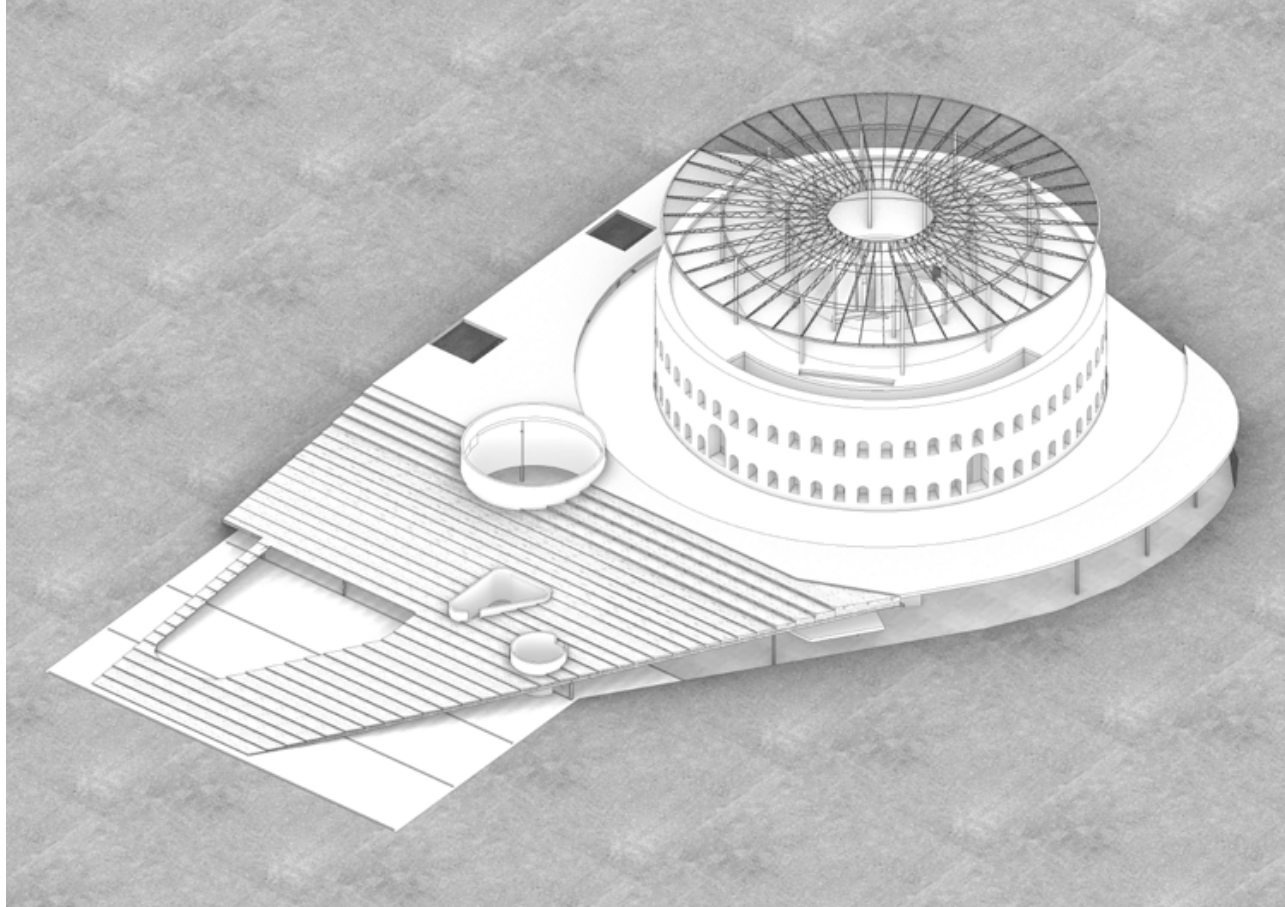

Reinforced concrete structure + Steel frame roof

ENVELOPE FRAGMENT 1 : 20

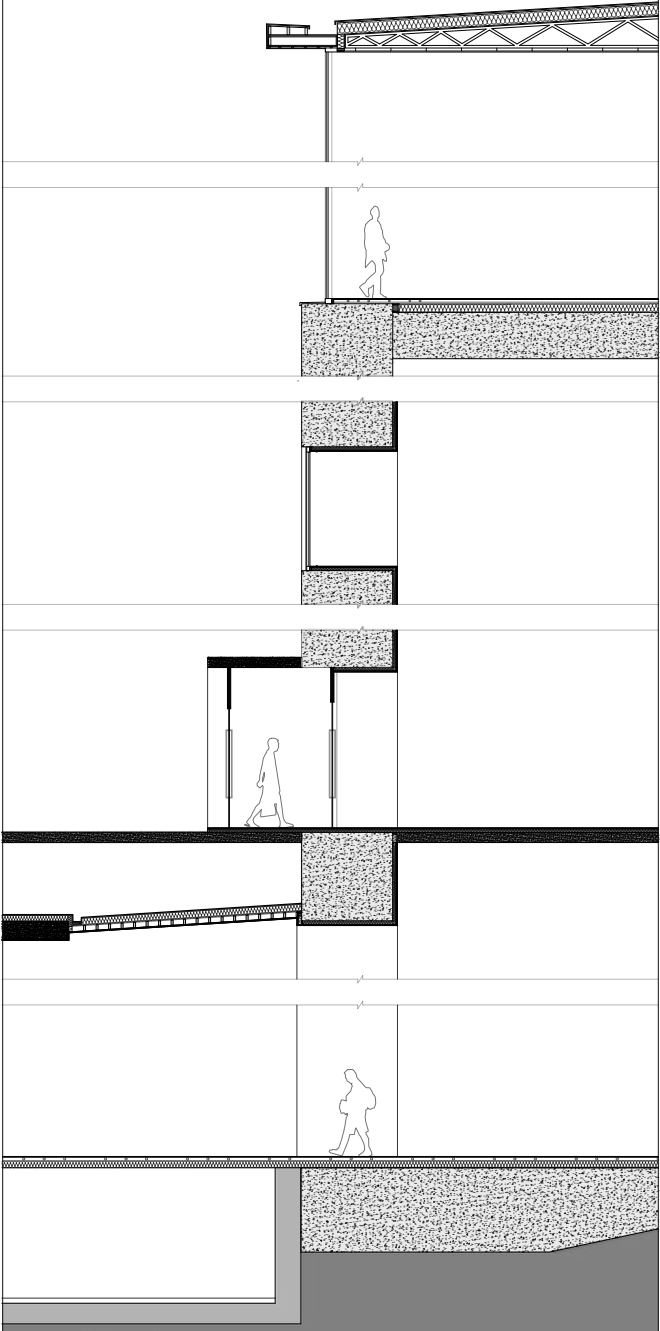
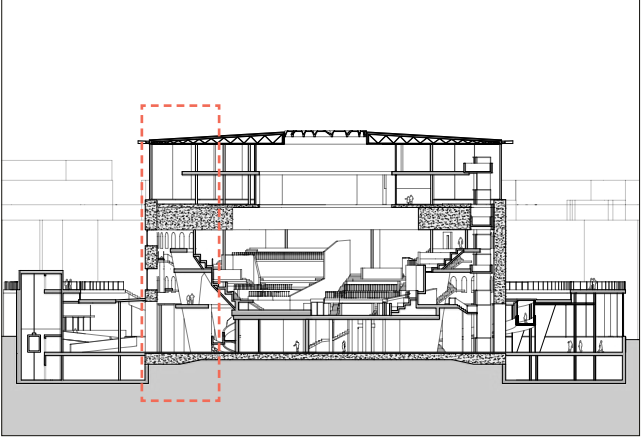

Development

SECTION DETAIL 1:5 1

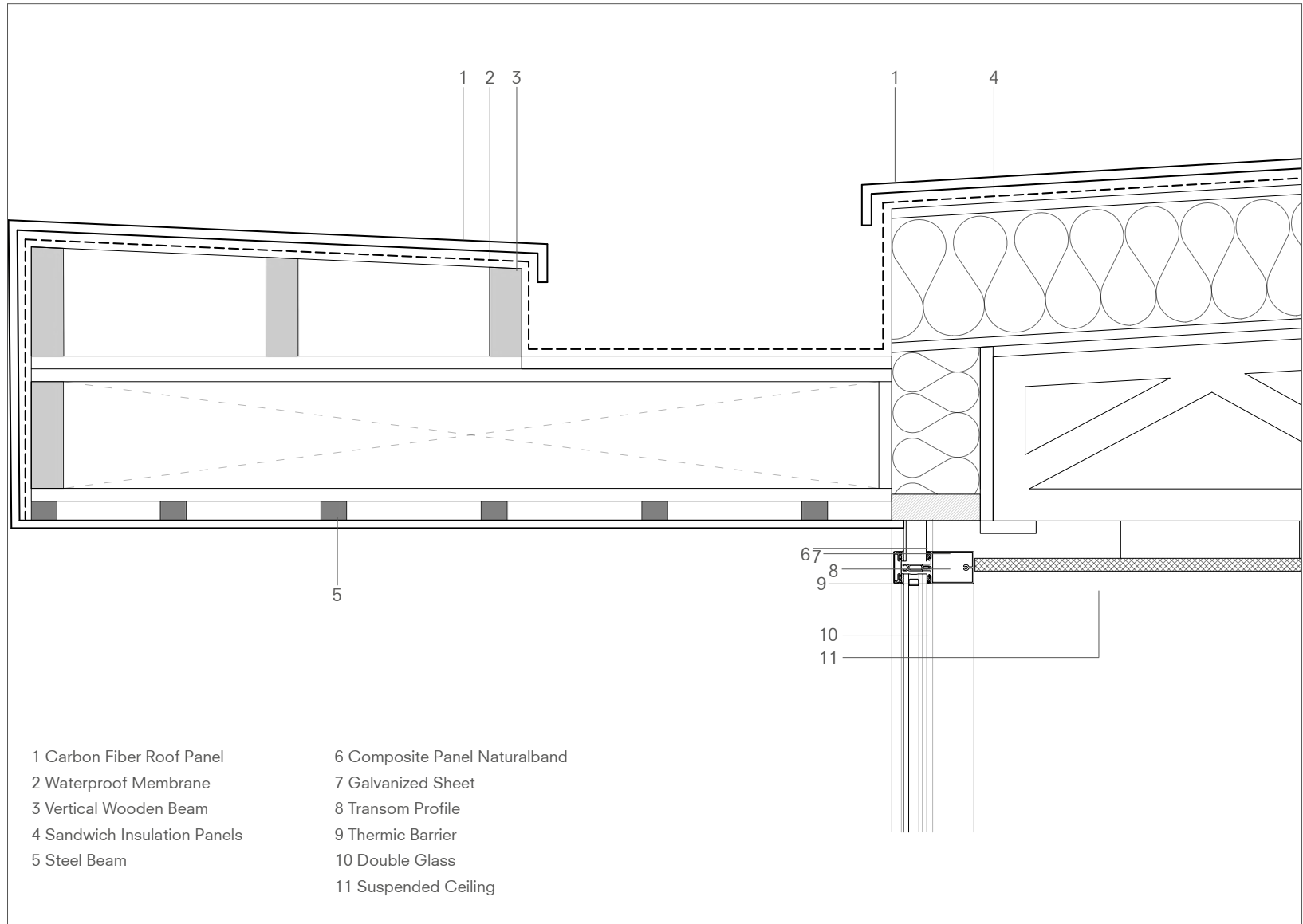
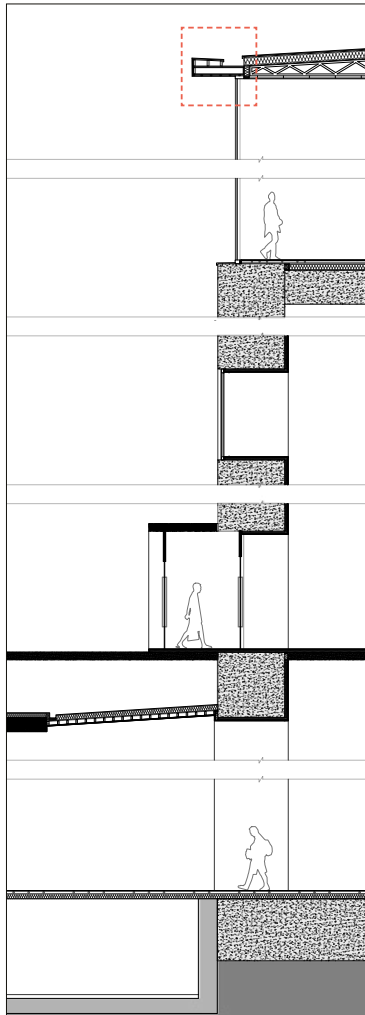

- | | |
|------------------------------|-------------------------------|
| 1 Carbon Fiber Roof Panel | 6 Composite Panel Naturalband |
| 2 Waterproof Membrane | 7 Galvanized Sheet |
| 3 Vertical Wooden Beam | 8 Transom Profile |
| 4 Sandwich Insulation Panels | 9 Thermic Barrier |
| 5 Steel Beam | 10 Double Glass |
| | 11 Suspended Ceiling |

Development
SECTION DETAIL 1:5 2

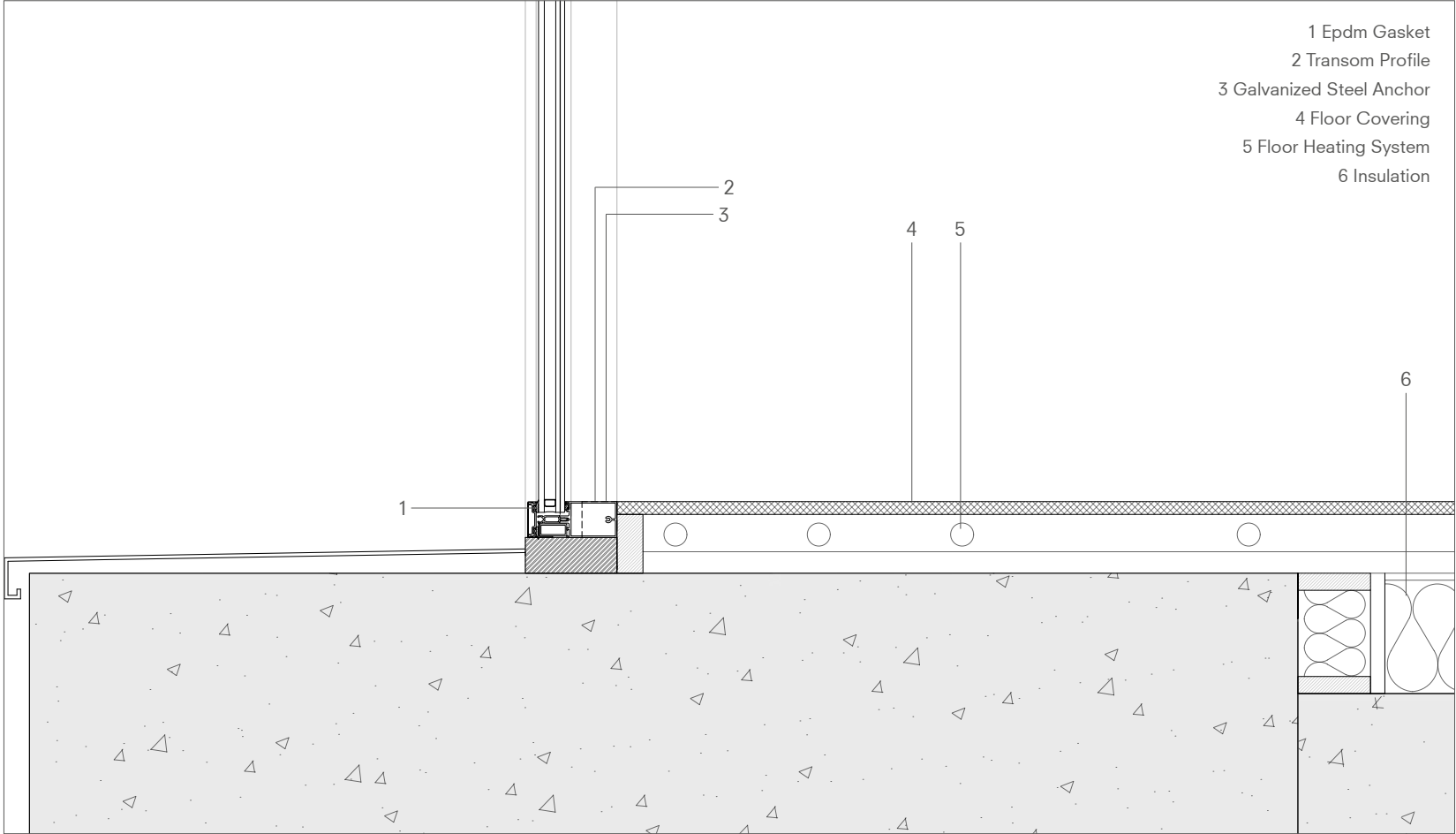
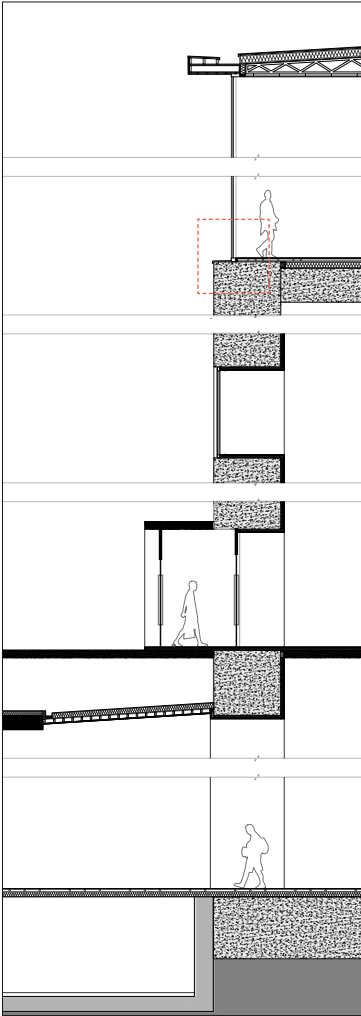

Development
SECTION DETAIL 1:5 3

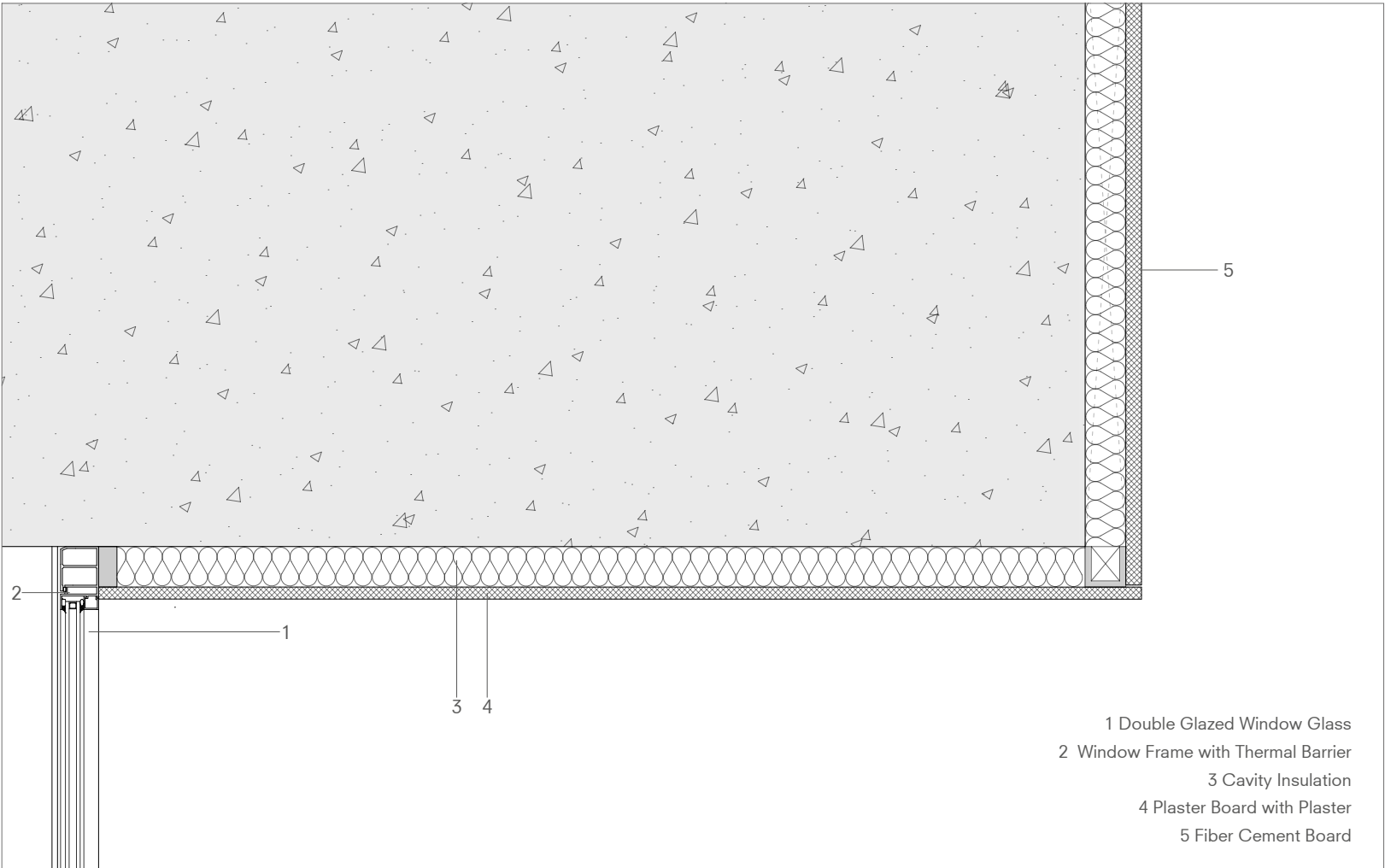
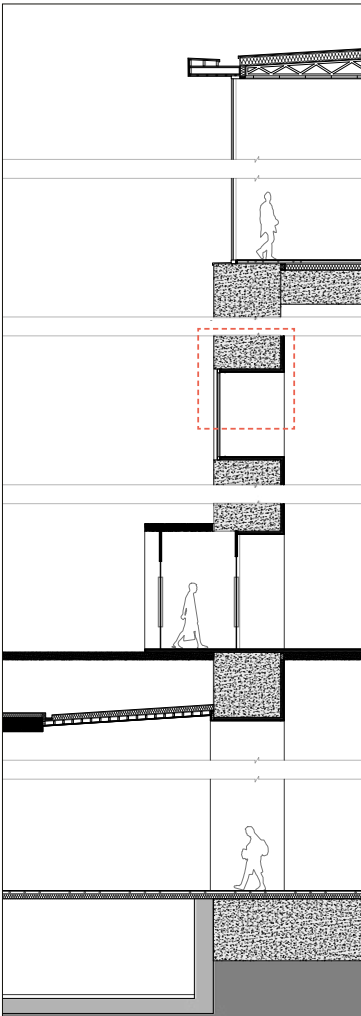

- 1 Double Glazed Window Glass
- 2 Window Frame with Thermal Barrier
- 3 Cavity Insulation
- 4 Plaster Board with Plaster
- 5 Fiber Cement Board

Development
SECTION DETAIL 1:5 4

- 1 Aluminum Roof
- 2 Aluminum Head Flashing
- 3 Wooden Plate
- 4 Wooden Beam
- 5 Fiber Cement Board
- 6 Insulation
- 7 Plaster Board with Plaster

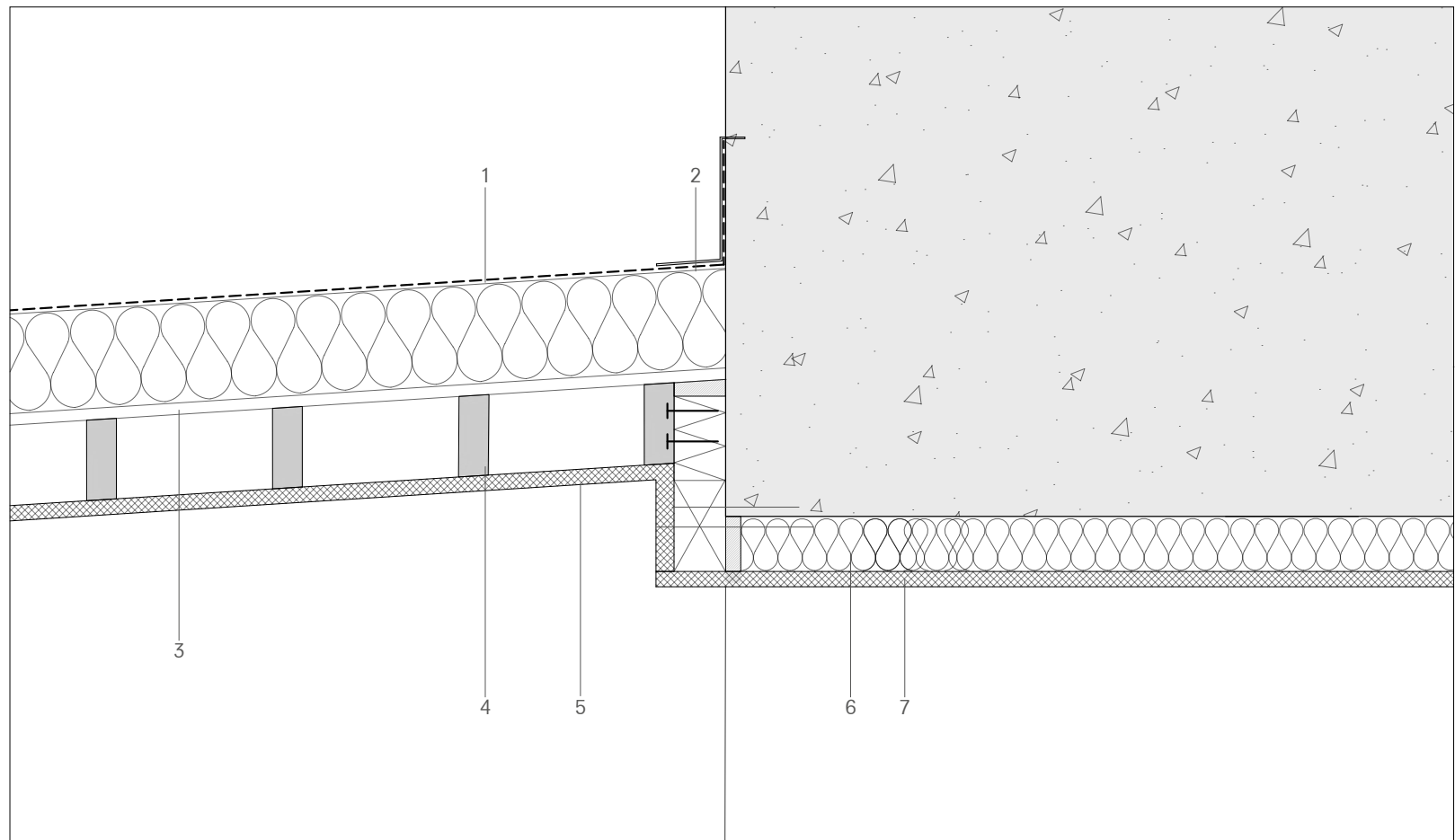
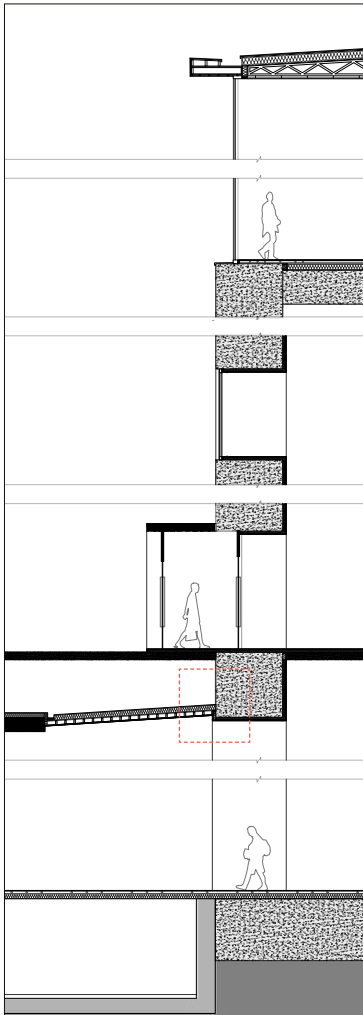

Development
SECTION DETAIL 1:5 5

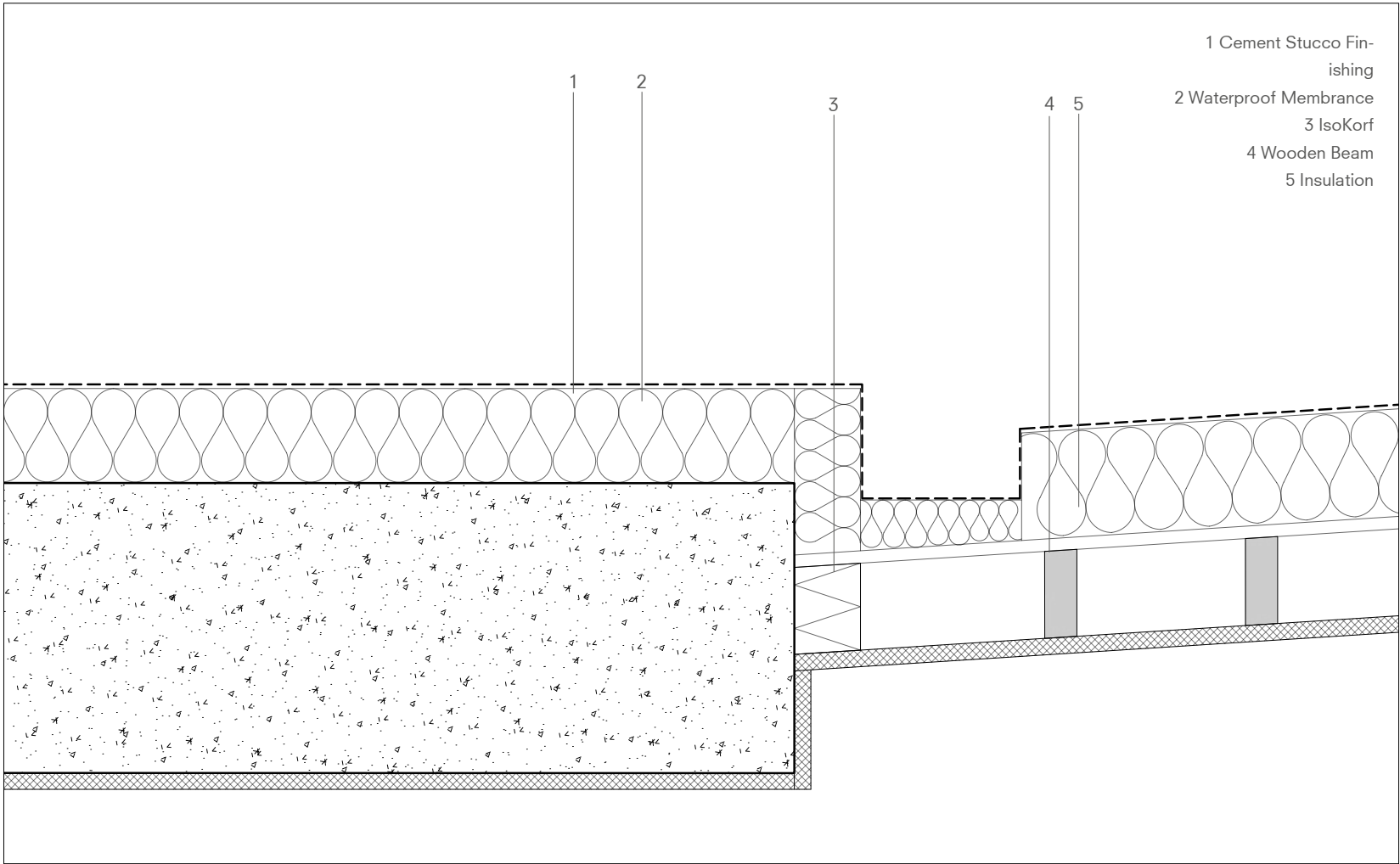
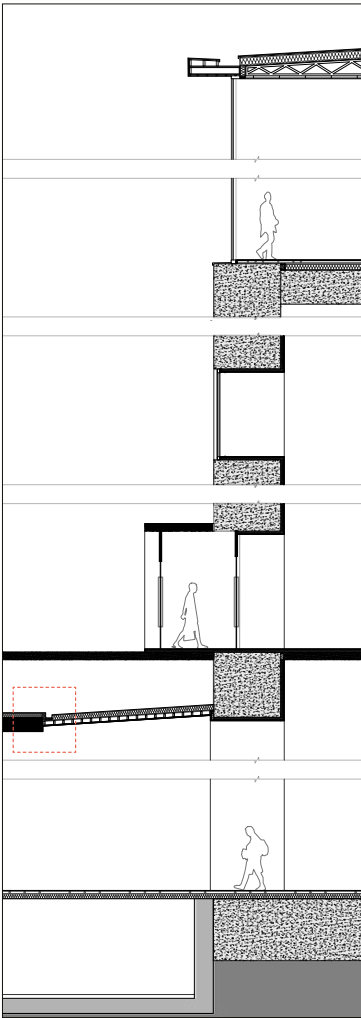

Development
SECTION DETAIL 1:5 6

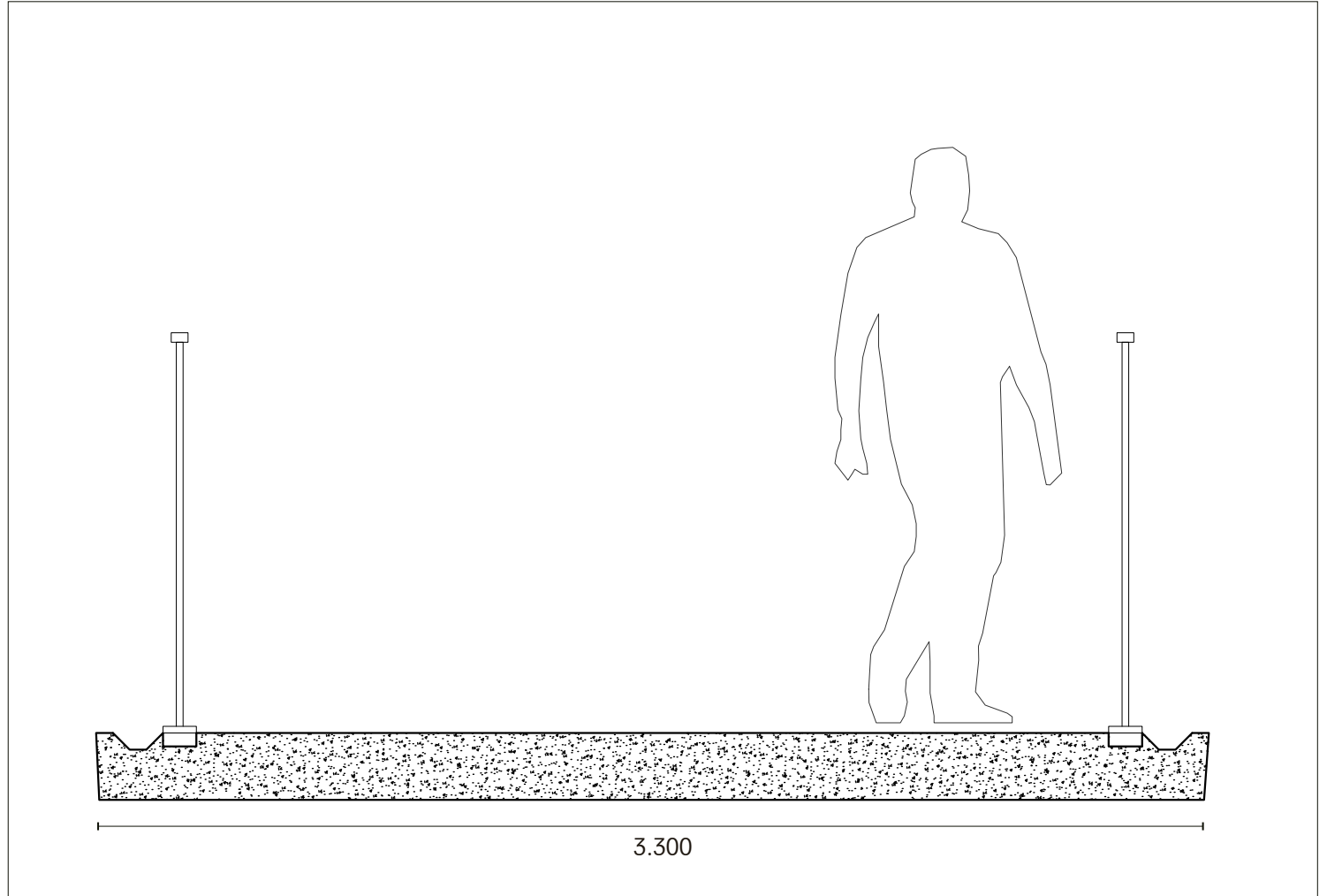
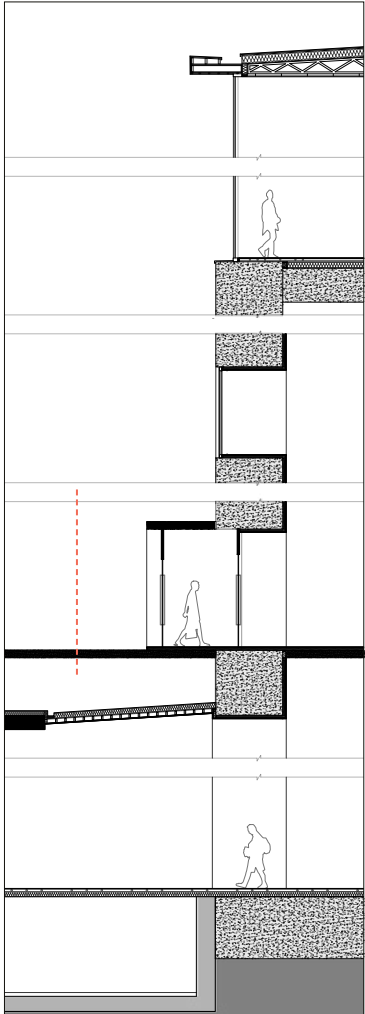

Development

RAIN WATER REUSE

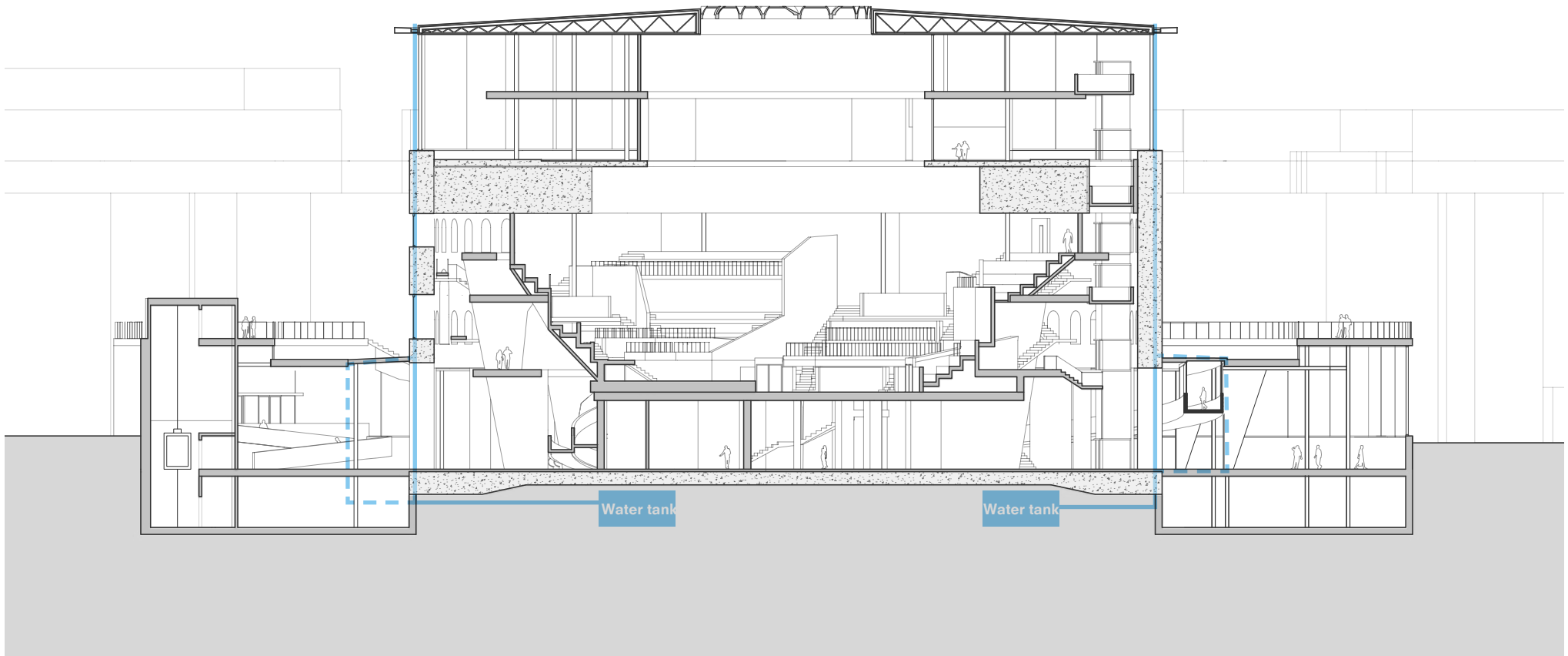

Development

INSULATION AND CLIMATE ZONES

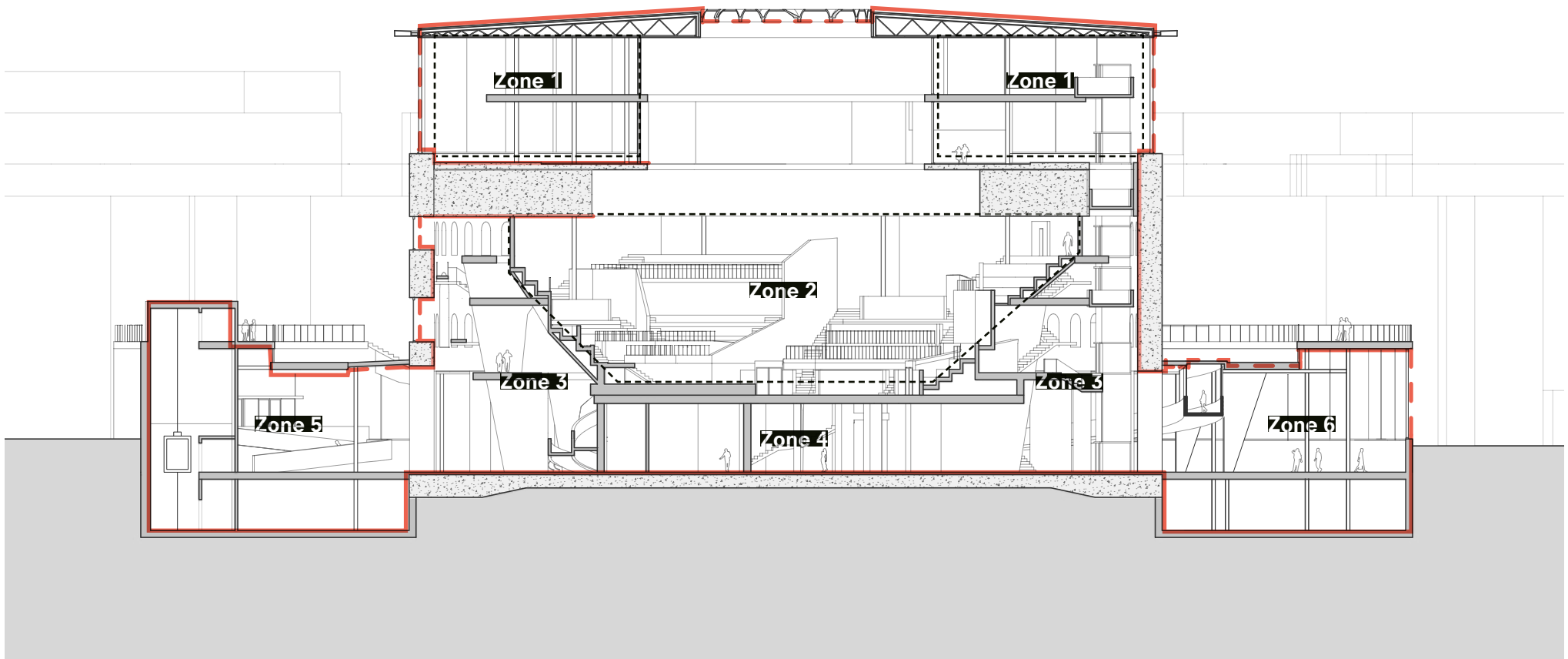

Development

CLIMATE CONTROL AND VENTILATION

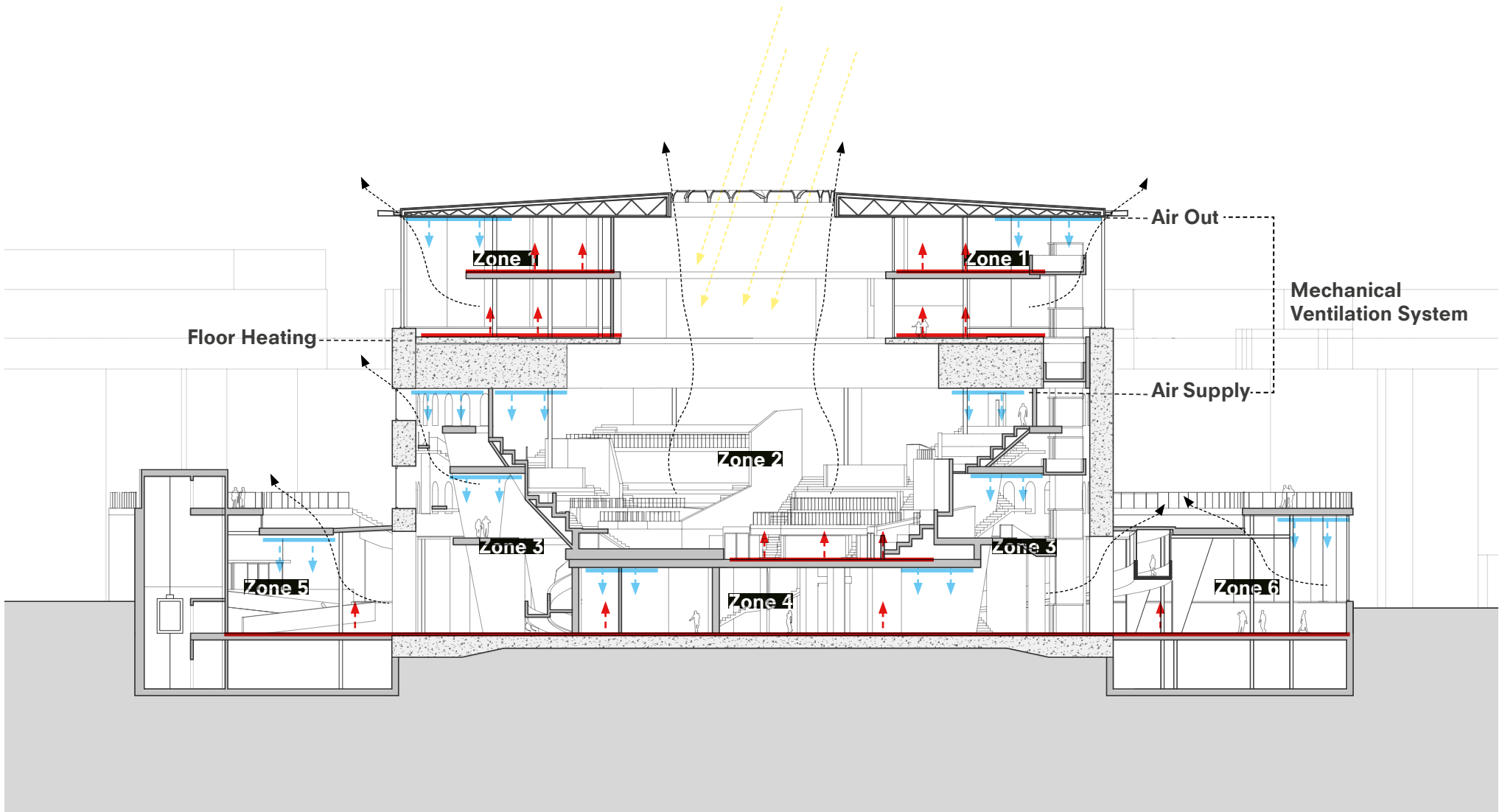

CONCLUSION

Conclusion

REFLECTION



Conclusion

REFLECTION

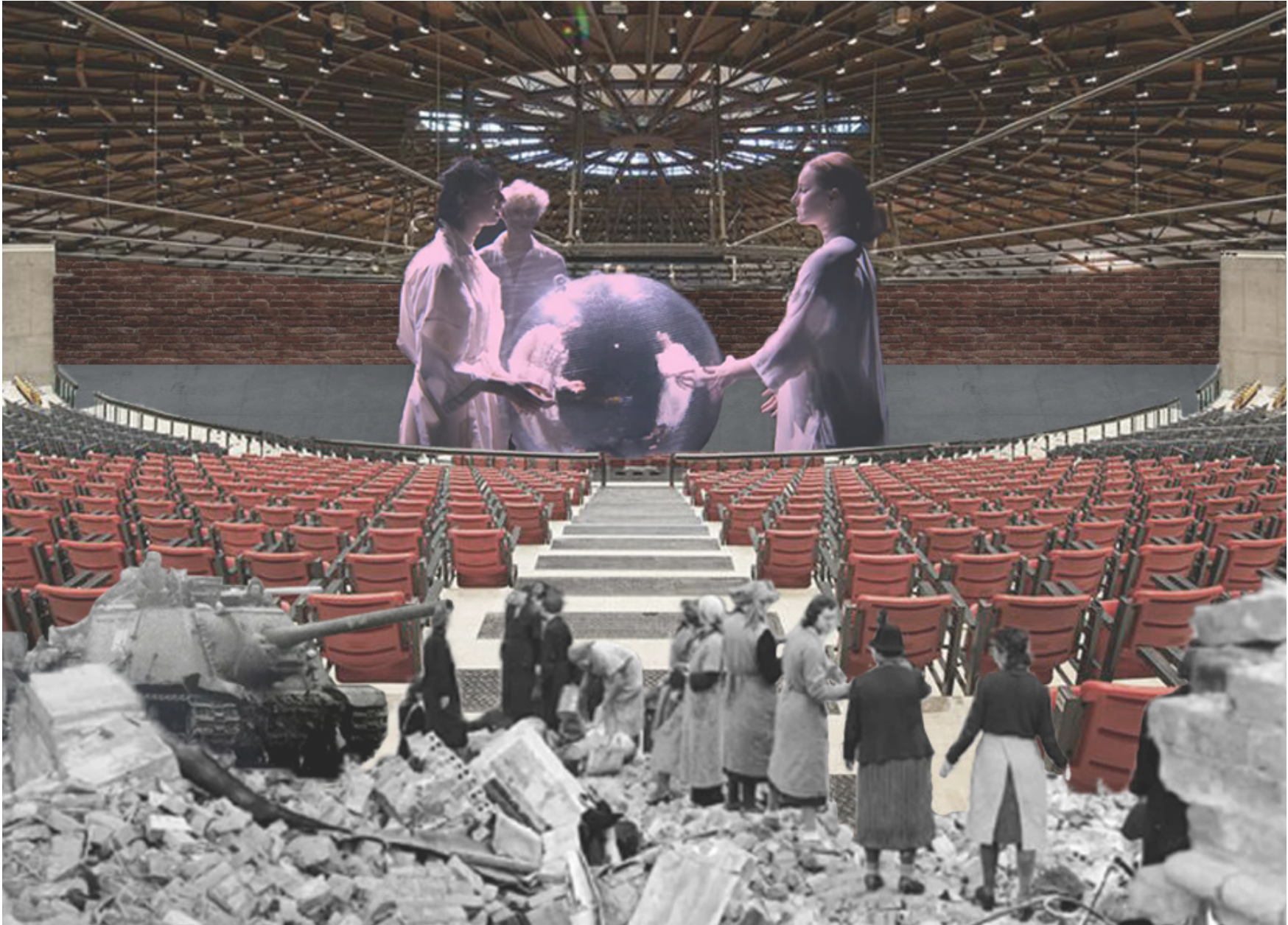

Conclusion
REFLECTION



Thank you!