

AIR GUARD

CIRCULAR
SKI-HELMET

A Vision for Transitioning
Ski-Helmets into the
Circular Economy and its
Systems of Maintaining,
Increasing & Regaining
Product Value.



Martin Steffner
Integrated Product Design
MSc. Graduation Thesis

 **TU Delft**

 **ATOMIC**

AIR GUARD

CIRCULAR SKI-HELMET

A Vision for Transitioning Ski-Helmets into the Circular Economy and its Systems of Maintaining, Increasing & Regaining Product Value.

MSc. Graduation Thesis
July, 2021

Martin Steffner

Integrated Product Design
Faculty of Industrial Design Engineering
Delft University of Technology

Chair

Bas Flipsen

Circular Product Design
Sustainable Design Engineering

Mentor

Wouter Kets

Design Aesthetics
Human Centered Design

Company Mentor

Peter Wirthenstätter

Atomic Skis

ACKNOWLEDGEMENT

I would like to say 'Thank You' to everyone who was directly or indirectly involved in this project and supported me throughout this time.

To Peter, as he was the main driver in starting this project and involved as expert, mentor and colleague. To my team at Atomic for challenging my concepts and supporting me from a distance with expertise, data and physical products. To Wouter, providing his mentorship, weekly digital coffee meetings and friendly conversations. To Bas, for making time in his schedule and supporting me with cutting edge Circular Design methodology and tools. To Jos, for supporting me and helping me to reflect on- and refine my ideas. To my team in China — to Ling, Brian, Hugo and Alvin for helping me bringing concept ideas further, for challenging my assumptions and for keeping me supplied with samples and materials. To my friends of Ammos, for participating in creative-sessions and providing creative input, wherever needed. To Marcel, for providing his experience in designing and consulting for the Circular Economy. To my colleagues at TU, helping me trial-run, test and refine my ideas. Last but not least, thank you to my friends, my family, and to Valentina for the support.

ABSTRACT

This thesis project aims at exploring the challenges of sustainability within the segment of ski-helmets. It should lead to locating opportunities for transitioning them into the Circular Economy.

Ski-helmets are single-impact items, comprised of multiple different materials in inseparable product assemblies that prevent disassembly and recyclability. They are discarded after critical impacts, when safety critical parts fail. This also happens, when product parts with crucial perceived value deteriorate visually or fail to fit current fashion trends. Facilitating repair or refurbishment is currently obstructed through certifications and future developments seem promising but unsure. After discarding, helmets are not recycled, which leads to the loss of resources, energy and value.

Different ski-helmets were analysed on their ease of disassembly and their environmental impact using tools like HotSpot-Mapping, Disassembly Maps and Life Cycle Assessment. A survey and interviews were conducted for gaining insights into user-behaviour and expertise in ski-helmets and beyond.

The project's outcome is a visionary concept for transitioning ski-helmets into the Circular Economy — the Airguard concept. The proposal includes a novel approach on energy-management, rather than using single-impact EPS-foam. A system of TPU air-vessels enables the absorption of multiple impacts and the structure can be easily restored through remanufacturing.



The Airguard concept is developed to fit into processes like recycling and remanufacturing. It is integrated into an assembly base with less different materials used, enabling product disassembly and improved access to parts with high impact, embedded energy and economic value — The priority parts.

The assembly base includes the possibility to change parts which subject to deterioration, like visors and soft-liners. Additionally, it provides a modular base for product add-ons and upgrades, increasing usability, flexibility and longevity. After the product's end of use, an incentive take-back system should enable retrieving used products to regain their value through recycling and remanufacturing.

As an intermediate step, the Eco-Savor concept was developed, focusing on recycling, while using the same assembly base as the Airguard concept, built around a core of trusted EPS. As a stepping stone, it should be used to improve product architecture and for gathering insights on part durability for later remanufacturing. A roadmap was developed to indicate development steps over the timeline of six years.

In the end, both concepts should stand as a vision towards sustainability, with many features to further explore and the possibility to gradually decrease environmental impact in ski-helmets.



1	Introduction	2
1.1	Problem statement & research question	4
1.2	Research & design approach	7
2	Context	10
2.1	Ski-helmets	12
2.2	Atomic skis	21
2.3	Circular economy	22
2.4	User behaviour & helmet lifecycle	26
2.5	Impact Assessment	32
3	Assessment of Current Ski-Helmets	36
3.1	Priority parts	38
3.2	Assessment setup	42
3.3	Hotspot analysis	46
3.4	Disassembly maps	50
3.5	Ecological impact & economic value	66
4	Key Findings	76
5	Concept & Vision	88
5.1	Concept strategy	90
	Project Vision	93
5.2	Vision Overview	97
5.3	Evolution & Revolution	100

6	Product Design	106
6.1	Airguard System	108
6.2	Re-Design for Disassembly	120
6.3	Maintaining Product (Part) Value	135
6.4	Increasing Product Value	144
6.5	Re-Design Evaluation	146
6.6	Airguard Shell	160
6.7	Sustainable Evolution	164
7	Discussion & Conclusion	170
7.1	Discussion	172
7.2	route to Circularity	176
7.3	Conclusion	180
8	References & Indexes	188
8.1	References	190
8.2	Indexes	194
9	Appendix	198
	Graduation Brief	200

ABS	— Acrylonitrile butadiene styrene
BOM	— Bill of materials
CO ₂	— Carbondioxide
CO ₂ -eq	— Carbondioxide-equivalent
e.g.	— example given
EPS	— Expanded polystyrene
EoL	— End of Life
EoU	— End of Use
Fig.	— Figure
HSM	— HotSpot Mapping
J	— Joule
kN	— Kilonewton
LCA	— Lifecycle Assessment
max.	— maximum
mJ	— megaJoule
ms	— Milliseconds
N/A	— not applicable
PC	— Polycarbonate
PET	— Polyethylene terephthalate
Tab.	— Table
TPU	— Thermoplastic Polyurethane
TRL	— Technology Readiness Levels
UV	— Ultraviolet (Radiation)
σ	— Standard deviation
Ø	— average





1 INTRODUCTION

Ski-helmets are currently considered as unsustainable — From materials used and a mostly inseparable product-assembly to a linear approach of marketing them. This thesis focuses on re-designing ski-helmets into sustainable products by transitioning them into the Circular Economy. This chapter outlines the approach of analysing the status-quo and redesigning the product in focus, including relevant research questions.

**1.1 PROBLEM STATEMENT
AND RESEARCH
QUESTIONS 4**

**Problem Statement
Company Involvement
Research Questions**

**1.2 RESEARCH & DESIGN
APPROACH 7**

**Process
Methodologies
Scope**

1.1 PROBLEM STATEMENT & RESEARCH QUESTIONS

1.1.1 PROBLEM STATEMENT

Climate change, resource depletion and loss of biodiversity are accelerated by the linear consumption pattern of take-make-waste or 'cradle-to-grave'. An opposing model of the linear economy is the Circular Economy. It is a systemic approach on keeping products and resources in infinite loops and therefore retain resources and maintain their value.

Ski-helmets are a lifesaving companion of the major part of the skiing- and snowboarding population, but are also considered a fashion item to most users.

Ski helmets are currently not designed with focus on the Circular Economy. They consist of multiple different materials assembled in in-mold- or glued-construction. These integrated assemblies are difficult to separate, they consist of unsuitable materials, like EPS and are therefore unqualified for recycling, which makes them unsustainable.

This is further catalysed by helmets being safety crucial items, which are advised to be replaced after a critical impact scenario. Furthermore, many users consider helmets as fashion items and replace them as they become psychologically obsolete. Also, as especially exposed parts are prone to wear and tear, environmental influences and the continuous placement in near proximity to people conducting sports activities, parts like shells and textiles are crucial for perceived value and can be therefore also subject to discarding the helmet, even before its real function would seize.

The unconditional requirements for the safety of the product are the main limitations and a challenge to overcome in re-designing the product to being implemented in the Circular Economy. At the same time, the safety and quality regulations, but also the users desirability to buy and use the product for a specific amount of time are essential in defining the vision and concept for the re-design of the product.

1.1.2 COMPANY INVOLVEMENT

Atomic is an Austrian manufacturer of skis and related products, including bindings, boots, garments and protective items like goggles and helmets. In 2020, Atomic sold up to 200.000 ski-helmets, compared to a global annual sales volume of 5 Million.

As Atomic currently transforms into a business model of 'Sustainable Value Creation', the current conditions are contradictory to these envisioned values.

This project should stand as a vision for Atomic for transitioning their product portfolio towards a circular business model. It would be a novel approach in a sector which is currently defined by unsustainable product design paired with high demands in safety, but also high volume and short lifecycles. It could provide Atomic with a new USP and the possibility to position themselves as a sustainable sporting goods manufacturer. The focus on recycling and remanufacturing can also improve Atomic's customer-retention, as it keeps them closer to the brand.

1.1.3 RESEARCH QUESTIONS

As previously stated, due to the composition of ski-helmets and the materials these inseparable in-mold or glued assemblies contain, they are not suitable for fitting the value flows of the Circular Economy.

Projects by De Fazio (2019 & 2020) and Vermaat (2020) focused on proposing re-design opportunities for specific product categories to fit into the repair- and refurbishment-cycles of the Circular Economy. However, the integration of ski-helmets and related products into these processes still has to be established. Ski-helmets are safety critical, strictly regulated, highly integrated and are prone to short lifecycles, caused by damage or psychological obsolescence. Therefore, the main- and sub-research questions of this graduation project will be:

Which development aspects need to be considered when embedding **highly integrated & safety critical consumer products** with **crucial perceived-value** into the framework of the **Circular Economy?**

INTRODUCTION

RQ1 What ensures the safety critical functionality of ski-helmets?

- RQ1.1 Which parts of ski-helmets are safety critical?
- RQ1.2 How can material health of safety critical parts be assessed to inform about their intactness and prevent early-discarding?

RQ2 Why are ski helmets currently discarded?

- RQ2.1 What is the current time of use for ski-helmets?
- RQ2.2 What are the most often recurring failures?
- RQ2.3 Are there non-safety-critical parts that are associated with the helmet's discarding?
- RQ2.4 What is the users current stance on sustainability within this product-category?

RQ3 What is the current state of ski-helmets regarding the Circular Economy?

- RQ3.1 What is the current market situation on ski-helmets and possible sustainable alternatives?
- RQ3.2 What are possible challenges with certification or legislation?
- RQ3.3 What is the current status regarding dis- & reassembly?
- RQ3.4 What is the current ecological impact?
- RQ3.5 What are possible challenges regarding used materials?

RQ4 How can ski-helmets be re-designed to fit into the concept of the Circular-Economy, in a timeline of five years?

- RQ4.1 Which strategies of the Circular Economy fit to ski-helmets?
- RQ4.2 How can the main functionality be re-designed to fit the Circular Economy?
- RQ4.3 How can the product architecture be re-designed to fit the Circular Economy?
- RQ4.4 Are there necessary intermediate steps to achieve the desired concept?

1.2 RESEARCH & DESIGN APPROACH

1.2.1 PROCESS

An important step towards re-design will be to assess current products in close detail, including their impact and their dis- and re-assembly, linked to their current product architectures.

Another important step will be to finding out about current user behaviour in ski-helmets, about parts that are prone to malfunctioning and ski-helmet's current time-in-use, about the user's preferences in buying helmets and their stance towards sustainability.

After this, a concept should be developed, providing a vision on how ski-helmets could be handled in a business-model after the transition from the Linear Economy.

Following this, the challenge will be to re-design the in-mold product or glued architecture with its many integrated parts. It is defined by industrialisation and the focus on safe fixation of elements, cost and production time. It should be designed to fit the proposed concept of maintaining value and for dis- and re-assembly. Lastly, the integrating element, the EPS foam is industry standard and finding an alternative solution or material for the function of absorption and deceleration in an impact scenario is essential for the re-design.

The design proposal should include a solution for a time of industrialisation of five years, yet also intermediate steps, leading towards this point with possible intermediate product states. Technology Readiness Levels (TRLs) should give a clear indication on maturity of developments and draw important milestones.

Different prototypes should be developed, to visualise the design choices made and the workings of the concept. Also, as this project includes the possibility to rethink energy-management as it is, possibilities for testing should be considered.

1.2.2 METHODOLOGIES

The thesis project includes usage, testing and reviewing the methodologies Hotspot-Mapping and Disassembly Maps. Furthermore, to assess product impact, fast-track lifecycle-assessments (LCAs) are used. To gain insights in the current behaviour of users, a quantitative survey is used, and for learning from the experience of professionals in design- and the ski-helmets industry, informal qualitative interviews are conducted on a regular basis. To gain input, creativity methods like 6-3-5 brainwriting should be used, but also hands-on, iterative development of design solutions through ideation, working models and early prototypes.

Technology Readiness Levels should be used to indicate maturity of development steps, Design Roadmapping the tool at hand to develop the advisory timeline.

The project follows the methodology of diverging and converging of the double-diamond approach, yet the planning focuses on using small time-increments of the Design-Sprint method.

1.2.3 SCOPE

The scope of this graduation project will be to conduct a case study on ski-helmets. This includes investigating their current ability to fit into the Circular Economy and the needed development aspects to improve or enable this fit. The solution space includes re-designing a representative Atomic ski-helmet to fit into the system of the Circular Economy and its adjacent business-models, enabling the product to flow within these circles. It can be assumed, that due to current certification boundaries, ski-helmets cannot be transitioned into a circular future at once, but intermediate steps need to be taken. Therefore this thesis should focus on providing a concept-vision for a future outlook of five years and a possible intermediate step as one of the first building blocks in reaching this vision.





ATOMIC

ENGINEERED IN AUSTRIA

2 CONTEXT

This chapter outlines the current knowledge base in helmet products, the company's current efforts in sustainability and the principles and strategies of the Circular Economy. It investigates current user behaviour and how impacts can currently be assessed, without analysing a product in full detail.

2.1 SKI HELMETS 12

**Helmets are Safety Crucial
Functionality & Ergonomics
Shell & Liner
Current Market
Scope
Standards & Regulations**

2.2 ATOMIC 21

2.3 CIRCULAR ECONOMY 22

**Definition
Resource Cycles
Design Strategies
Design for Ease of Disassembly
Product Value**

**2.4 USER BEHAVIOUR &
HELMET LIFECYCLE 26**

**Current Knowledge Base
Quantitative Survey**

2.5 IMPACT ASSESSMENT 32

**Passive Impact Indicators
Active Impact Assessment**

2.1 SKI-HELMETS

2.1.1 HELMETS ARE SAFETY CRUCIAL

Helmets are a live-saving companion of users in many different fields. From people working in construction sites to motorized transportation like motorbiking, they are an important piece of personal safety gear. Besides professional usage and high speed protection, helmets are spread over many different disciplines of recreation — mostly in sports. From biking to horse-riding, from skating to snowboarding and skiing, helmets play an intricate role within these activities.

Their main functionality is keeping their users safe in the event of a crash and to prevent injuries to the brain, the skull and the scalp,

especially concussions and severe head injuries. In sporting, head injuries account for almost 50% injuries per body region and concussions make 15% of all sports injuries. (McIntosh et al., 2011)

Depending on the direction of the impact, forces acting on the brain yield different loads. A radial impact to the head will cause linear acceleration while a tangential impact to the head's centre of gravity will cause acceleration in a rotational

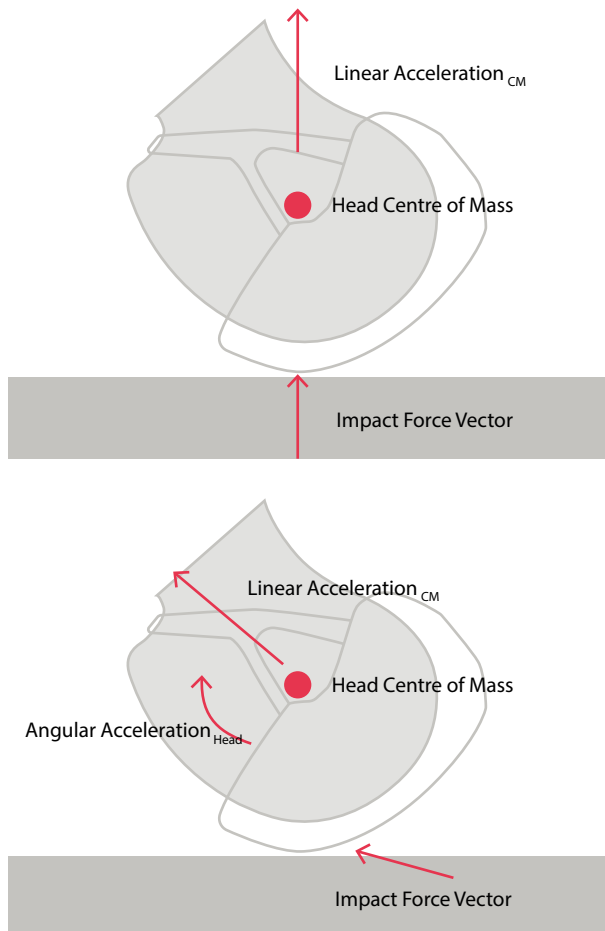

Fig. 1 — Linear and oblique-impact (McIntosh et al., 2011; own visualisation)

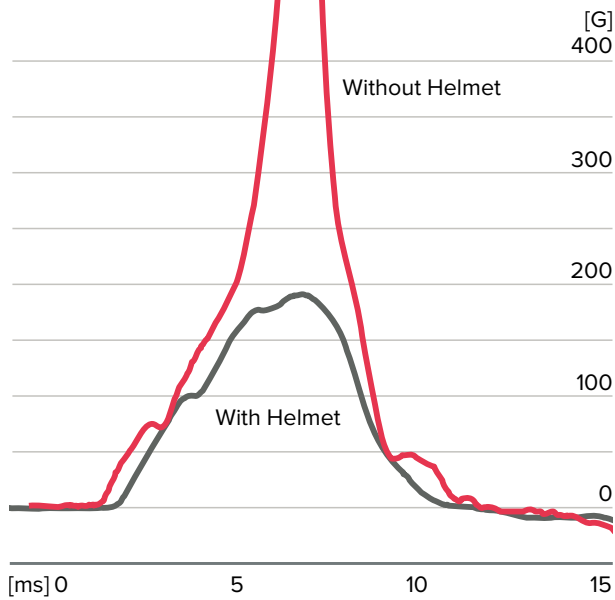

Fig. 2 — Schematic of impact-scenario forces (Mills & Gilchrist, 2006; own visualisation)

matter — two scenarios that almost never appear in a pure way, but rather in combination — in direct or oblique-impacts. These can cause strain to the brain-tissue and lead to severe brain injuries. (Gennarelli et al., 1987; Fig. 1)

Energy Management

The occurring acceleration is acting with forces of multiple kN onto the brain and is followed by a sudden deceleration. Helmets are developed to extend the time period in which the user's head is accelerated and decelerated in the event of an impact — usually by around 6ms, rather than under 1ms, and therefore decreasing the peak-impact acting on the brain. (Fig. 2) This is mostly



Fig. 3 – Explosion graphic of current Atomic helmets

CONTEXT ANALYSIS

achieved through the helmet core (liner), which is made from crushable foam, transforming the impact energy through compressing without being fully compressed and without springing back in an elastic way. This is dependent on the thickness and density of the foam. Before that, the initial incoming force is spread over a larger surface area by a hard outer material — the shell. The shell increases the partition of foam actively engaged in transforming the energy and will even crack from severe impacts. (Newcomb, 2017; helmets.org, n.d.-1; Mills & Gilchrist, 2006)

Multi-directional impacts

This protective mechanism is mainly effective in direct impact scenarios with linear accelerations. However it can also help in reducing the loads occurring in angled and multi-directional impacts,

with added rotational acceleration. Better protection in such impact scenarios is proposed through technologies that aim at allowing the user's head to move inside the helmet in a defined extent and reduce harmful rotational motion that could be transferred to the brain-tissue. Brands like *Mips* are well known to tackle multi-directional impacts and add a separate layer of moving surface between the user's head and the liner. Atomic uses a self-developed technology called *AMID (Atomic Multi-directional Impact Deflector)* to achieve the same effect, using dual-density foam pads at the same position. Other technologies with similar functionality are also available from other brands. (McIntosh et al., 2011; Mips, n.d.; Atomic, n.d.-1)

Fig. 4 — Atomic helmet features



2.1.2 FUNCTIONALITY & ERGONOMICS

Optimal placement and fixation to the user's head is important for the helmet's liner and shell to deliver their functionality in the event of an impact. This requires that the helmet is properly fitted to the user's head and the head is correctly positioned in the helmet. This also demands, that the helmet is fixated in a way, that it doesn't come off within an impact.

Fitting System

Most helmets, including bike-helmets and ski-helmets are provided in different sizes, fitting to different circumferences of heads. For fine-adjustment to the individual head-circumference & -shape, most products are equipped with a flexible fitting system. This can be also combined with a height-adjustment system to position the circumference-adjustment and further cater to the different head-shapes of users. The fit is further secured by soft paddings that are placed in strategic positions — or, in the case of ski-helmets by full-cap soft-liners, also covering the ears. Next to safe placement, the padding ensures comfortable wearing, thermal properties like keeping the user warm, as well as hygienic measures, like anti-odour and anti-microbial properties. However, they fully compress in impact scenarios and besides positioning, don't add safety properties. (Atomic, n.d.-1)

Retention-System

In addition, helmets are equipped with a system to securely fixate the helmet to the head, especially in impact situations. This usually comprises a textile band that runs under the user's chin — the chinstrap. It can be adjusted to the user's head-dimensions and is safely locked mechanically via a buckle system, most often including a male and female part with a quick release. Other systems are also available, e.g. magnetic systems. All mentioned items are important considering user interaction, as they have to be easy to adjust. (helmets.org, n.d.-2; thingsthatfold.com, 2020-1)

Ventilation

Furthermore, most helmets are designed for providing suitable ventilation to the user's head, as hot outside-temperatures, physical activities and insulating materials like foams can lead to heat-induced discomforts through increased

skin-temperature and sweating. Bike-helmets bear large ventilation-holes and inside channels for air-flow, depending on the discipline. In addition, ski-helmets even provide the possibility to open and close ventilation holes through mechanical ventilation-units. (Bogerd et al. 2014; Atomic, n.d.-1)

Visor

Lastly, ski-helmets can be designed for different optical systems to be used in combination. This can include ski-goggles or glasses that are not integrated into the product architecture, however, temporary fixations like goggle-strap clips are usually provided then. Helmets can also include an integrated lens (visor) which can be rotated to be set in place and usually interchangeably mounted through different mechanical solutions.

CONTEXT ANALYSIS

2.1.3 SHELL & LINER

Liner

Foam is still the main part of helmets nowadays, being the main material used for the liner, which is responsible for the energy management in impact situations. As there are different foam-materials in use, EPS (Expanded Polystyrene) is most commonly included in bicycle-, ski- and other sports-helmets. It is crushable and therefore suitable in scenarios of a single, hard impact. The impact acceleration is slowed down, some energy is transformed into heat and the material doesn't push back but stays crushed and only recovers ignorable. This is also a downside to the material, as it caters to the one-use property of the product — one significant impact and the material is not usable anymore in that area, ultimately introducing the item's end of use.

EPS is molded by filling a pressure mold with polystyrene granules (beads), with an average diameter of about 0,3mm. Following this, the granules are expanded via pressure, heat and a blowing agent like Pentane. Through this, the beads are tightly connected and form a solid structure. (helmets.org, n.d.-3 & n.d.-4)

Fig. 5 — Different helmet-technologies

From ABS-hardshell (red) to PC in-molded shells (blue) and different hybrids in-between.



Shell

The shell can be made from multiple different materials, from PET in cheaper helmets to ABS and Polycarbonate in more expensive models. Both thermoplastics are strong and rigid, yet flexible — they provide high impact resistance and are suitable for usage in hot and cold temperatures. ABS is used in helmets that need a harder, more durable and scratch-resistant shell, it is however also heavier than PC and needs thicker wall-thickness to provide the needed impact-protection. Polycarbonate is used for products that have a focus on lightness, with the ability to provide higher impact-strength than ABS and can therefore be used in thinner wall thickness — 0,7mm is a common wall-thickness. (Granta, 2019-1 & 2; thingsthatfold.com, 2020-2)

The foam-liner and the shell can be joined in different ways, depending on use case and needed properties, e.g. durability and weight.

Hardshell-Construction

In this product architecture, the EPS foam and the shell (mostly mold-injected ABS) are pre-fabricated and then are mounted together with glue or adhesive tape. This construction is mostly used, because ABS has great properties in surface-durability and it makes the helmet more rigid and stable. However, it is also heavier, than its counterpart — the In-Mold construction. Another downside to the hardshell-construction is that possible damages of the helmet after a crash can be difficult to assess. The ABS-shell can hide dents



and bad product-health, leading to damages being overlooked.

In-mold Construction

The main difference to the hardshell-construction is that the shell (thermoformed Polycarbonate) is added to the foam-injection mold and is then already in place, when the foam (most likely EPS) gets expanded. This achieves a great bonding between liner and shell, with a lighter construction, as the PC is significantly thinner. The adhesion of the EPS to the shell also provides a much better assessibility of product health, as dents are visible through the shell. (Peter Wirthenstätter, 15.02.2021, Appendix B)

According to a current Atomic models' bill of materials (BOM; Appendix F), the in-mold construction also includes other parts, needed for the fixation of fitting-mechanisms, the soft-liner and the retainer-straps. These parts, like inserts and baskets, are in-molded with the EPS too, even in hardshell-systems. Materials in use are Nylon (as it has a high melting point and is durable, also in the molding process) and furthermore stainless-steel, steel or brass for snaps and pins. (Granta, 2019-3)

According to Peter Wirthenstätter (12.04.2021; Appendix B), the in-mold construction was ski-helmet's latest 'paradigm-shift', as it allowed the production of lighter helmets.

Hybrid Systems

Both systems, as priorly stated, have desirable properties and also downsides, therefore hybrid constructions exist to combine the systems for dif-

ferent use-cases. These constructions can include in-mold and hardshell partitions — in two way splits with partitions of side and top parts, and also more sophisticated helmets with three different sections, made from ABS and/or PC. (Fig. 5) Parts not involved in the in-molding process are mostly mold-injected prior to the assembly process.

Other marketed technologies

Next to the helmet-systems mentioned before, there's also other solutions available. Koroyd offers a technology, based on a honeycomb structure of plastic tubes — about the diameter of a plastic straw — welded together forming a lightweight structure that can act as energy transforming part of helmet liners while providing breathability. (Koroyd, 2020) Smith, amongst other companies, offers helmets with this technology, combined with an EPS foam structure, keeping them in place. (Smith, 2020; helmets.org, n.d.-5) The technology is promising, however it can produce skin-abrasions due to friction, inflicted by sharp edges of the honeycomb material. (Peter Wirthenstätter, 15.02.2021, Appendix B)

Wavecel is a similar technology, with a three-dimensionally formed mesh, placed alongside an EPS-liner. The technology is designed to fulfil a part of the energy-management system, but also to tackle oblique-impacts, like the MIPS-system delivers. (wavecel, n.d.) (Fig. 7)



CONTEXT ANALYSIS



Fig. 6 – EPS- & cork-liner helmet (Bollé, 2021)

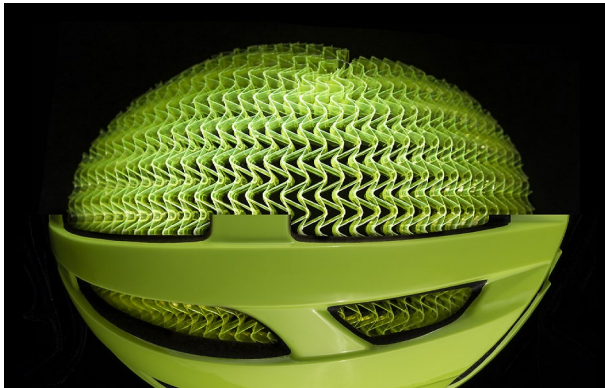

Fig. 7 – Wavecel technology (Wavecel, n.d.)



Fig. 8 – Folded paper helmet concept (Shiffer, 2017)



Fig. 9 – ABUS cardboard helmet (Stevenson, 2015)

Sustainable alternatives

HEXR takes a similar approach as Koroyd and Wavecel, the company produces bike-helmets with a 3D-printed hexagonal honeycomb structure, consisting castor bean oil, with other parts being made from undeclared petroleum based plastics. The helmet is customized via 3D scanning and the outer shell can be detached from the liner. (hexr.com, 2020; helmets.org, n.d.-5)

Ski- and bike-helmets are also in variants following more sustainable approaches. Bollé and BBB both recently introduced helmets with EPS-liners, containing up to 20% cork particles, next to the traditional EPS-beads. (Bollé, 2021; BBB, 2021) Suppliers like Strategic Sports (n.d.) offer concepts like Biodome, containing helmet liners made from recycled EPS, paddings from bamboo fabric and other plastic components made from 100% recycled plastics, however, still in the traditional in-molded product assembly.

Other technologies focused on a more conceptual approach, like the eco-helmet (Fig. 8), using folded paper to mimic the energy-management capacity of standard EPS-helmets. In this concept, no shell was used. (Shiffer, 2017) Companies like ABUS took this approach further and combined a core made from corrugated-cardboard with a sturdy shell. This concept was not perceived well because of weight, functionality and the overall look, and was discontinued therefore. (Stevenson, 2015)

2.1.4 CURRENT MARKET

The global ski-market includes around 110 million users, with 60 million users in Europe alone. The segment of ski-helmets is currently benefiting by the growing acceptance and use of helmets by the general population of skiers.

The global annual sales volume of ski-helmets is estimated to around five million units, with Atomic selling 193.911 ski-helmets in 2020. (Fabian Zeidler, 15.02.2021, Appendix C)

2.1.5 SCOPE

Considering the availability of alternative, sustainable options, these are still niches on the market, or are never brought to market. The analysis and re-design approach within this graduation thesis focuses on ski-helmets that are commonly sold — more precisely three ski-helmets intended for usage with goggles and two helmets with visors. Out of these, two are designed as in-mold- and one as hardshell-construction and two as hybrid solutions. As the available time within this thesis is limited, these two product-variants are used as representatives of the category of helmets and are expected to yield results, usable for products of the whole category.

2.1.6 STANDARDS & REGULATIONS

Certification process

Ski-helmets are safety crucial products, and as such are therefore subject to strict standards and regulations regarding their performance. These standards, like CE EN 1077 (European standard) and ASTM F 2040 (American National Standard) focus on helmets for non-motorized snow-sports and define safety features within this category, but also how these should be tested.

The standards include testing of energy-management and deceleration during linear impacts, resistance to penetration, the effectiveness of the retention system and the overall strength of the retention system. They also include various conditionings under which the helmets are tested, including room temperature (20°C), cold temperatures of -25°C and artificial ageing, involving alternating heat- (70°C) and UV-exposure.

Within CE EN 1077, the shock absorbing capacity is measured in the amount of acceleration reaching the headform, in a simulated scenario of dropping the headform and helmet from a height of 1.500mm onto a flat anvil. The measured peak acceleration should not exceed 250 g in the European standard (300 g in the ASTM standard). When tested for penetration, a striker is used to punctuate the helmet, which should not lead to the striker touching the headform. The retention-system effectiveness measures if the helmet comes off the headform, if an impact force is acting on it. The retention-system strength measures the elastic and plastic deformation of

the chinstrap in an impact scenario (max. 35mm elongation during impact and max. 25mm plastic deformation). Additionally, durability is assessed, regarding sharp edges and other dangers that can arise after the product being exposed to the before mentioned impact scenarios. Impact scenarios and conditionings are combined. CE EN 1077 includes two classes of protection (A & B), separating helmets with class A protecting a larger area of the head and B leaving the ear-section unprotected but providing better hearing. The standards furthermore include regulations for information that is visibly marked on the helmet and additional information supplied by the manufacturer. This also includes the notion, that helmets which have been subject to violent impacts should be discarded. (European Committee for Standardization, 2007; ASTM International, 2011)

Status on repair, refurbishment and remanufacturing

Current legislation makes repair or refurbishment of safety-critical parts difficult, as only original materials and production processes are valid. (Wirthenstätter, 11.02.2021, Appendix B; CEN/CENELEC Webinar 18.03.2021, Appendix E) Parts with crucial perceived-value, like soft-paddings can be replaced, but it is either not possible to remove these (chin-paddings), or spare parts are not available. Organisations like CEN/CENELEC made first improvements to the repair, reuse and upgrade of energy-related products with the standard EN 45554 (CEN/CENELEC, 2017), however such a standard is still not in place for safety-critical products. To tackle this, CEN/CENELEC is part of many workgroups dealing with progresses in this area, and webinars are held with members of personal-protective-equipment industry, policy and standardisation.

There is further progress within the industry, with associations like the Austrian association of sporting goods manufacturers and sports equipment suppliers (VSSÖ — Verband der Sportartikelerzeuger und Sportausrüster Österreichs) is actively looking into gaining influence in certification processes, and also create more sustainable movement within their own industry, to be prepared for upcoming legislations, both on the level of the European Union, but also internationally. The driver here is, that products like skis are considered 'products with high embodied-energy', which makes processes like incineration difficult. Ski-hel-

CONTEXT ANALYSIS

mets can be considered to also follow in that direction. (Holzer, Director anticipation & advanced research Atomic, 08.04.2021, Appendix D)

Remanufacturing involves the OEM (Original equipment manufacturer) of the product, and would be a feasible way to achieve recertification, as this involves original material and processes. (Ellen Waßmann, Chairwoman german footwear and leather goods industry, CEN/CENELEC Webinar, Appendix E) However, as OEMs of personal-protective equipment commonly and currently are located in China, the facilitation of this process becomes difficult again, as logistics are difficult to maintain. This is relevant, as most helmets, including the Atomic ones, are produced in China.

The certification of ski-helmets currently involves a lengthy and expensive process, taking times of up to one year and involving investments in four-digit Euro-amounts. Any change, made to an already certified product demands a re-certification — even if the change only includes a different coloured EPS liner, e.g. (Peter Wirthenstätter, 15.02.2021, Appendix B)

2.2 ATOMIC SKIS

Atomic — officially Atomic Austria GmbH — is an Austrian company specializing in manufacturing and selling skiing-related products, like skis, bindings, poles, helmets and other protective items and apparel and gear, but also services like fitting and customization. Looking at this product portfolio, Atomic offers a full range of products to the skiing population. (Atomic, n.d.) The company was founded in 1955 by Alois Rohrmoser and is since then based in the Austrian Alps, with its main factory in Altenmarkt, opened in 1971. Atomic was acquired by Finnish company Amer Sports in 1994, after its insolvency and is now part of Amer’s brand portfolio, next to other sporting-goods brands like Wilson, Salomon, Suunto, Arc’teryx, Armada etc. (Atomic, 2014) Furthermore, Amer Sports was acquired by Chinese Anta Sports in 2018. (Reuters, 2018) Looking at the global ski-market, this is a distinct situation, being part of a sporting-goods only conglomerate.

Atomic and sustainability

Following the commitment proposed by the European Union of reducing emissions by 55% until 2030, Atomic has set further measurements for sustainability into place. Current projects focus on using renewable energy for heating ski-presses and the excess heat is used to heat the factory buildings. Within the production process, plastic waste is re-used through direct recycling, reducing the usage of primary material in ski-production by 22%. Efforts in industrialisation, with focus in lean-manufacturing has led to reductions in production waste, including full products. (Fig. 10)

Next to production orientated measures, Atomic supports organisations like Protect our Winters, an organisation in place to countering climate-unfriendly behaviour. (Atomic, 2019)

Currently, efforts for sustainability are process based, with no specific measurements in place for products and their End-of-Life. However, as stated on the previous pages, Atomic is currently collaborating with the Austrian association of sporting goods manufacturers and sports equipment suppliers, in dawn of stricter legislations demanding OEM’s to facilitate the EoL scenarios of their own products. (Holzer, 08.04.2021, Appendix C)

Fig. 10 – Atomic ski manufacturing

Sustainability within Atomic currently concentrates on lean-manufacturing and process-

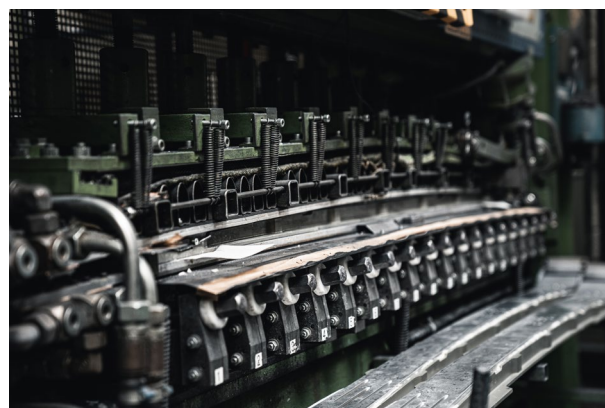

2.3 CIRCULAR ECONOMY

2.3.1 DEFINITION

The Circular Economy is a concept that stands in opposition to the current economical principle of the Linear Economy. This aims at replacing the approach of ‘cradle-to-grave’ — as is producing products which are destroyed after their consumption, with either incineration or landfill at their End of Life (EoL). The Circular Economy inherits an approach of keeping resources and values in on-going circular flows. (Ellen MacArthur Foundation, 2012; Bakker et al. 2019)

As nowadays, there is a multitude of definitions of the Circular Economy available, with different focus points, Kirchherr et al. (2017) developed the following definition, after analysing 114 different definitions:

[The Circular Economy is an] economic system that replaces the ‘end-of-life’ concept with reducing, alternatively reusing, recycling and recovering materials in production/distribution and consumption processes. It operates at the micro level (products, companies, consumers), meso level (eco-industrial parks) and macro level (city, region, nation and beyond), with the aim to accomplish sustainable development, thus simultaneously creating environmental quality, economic prosperity and social equity, to the benefit of current and future generations. It is enabled by novel business models and responsible consumers.

Concluding from these sources, the Circular Economy is a combination of reducing, reusing and recycling activities, with the need of new business models and the necessity of a systemic shift.

2.3.2 RESOURCE CYCLES

Slowing Resource Loops

Products should stay in loops longer, without losing their integrity. This can include designing long-life goods and extending product-lives through

services of repair, refurbishment and remanufacturing. (Bakker et al., 2019; Bocken et al., 2016)

Closing Resource Loops

Ultimately, products should be recyclable, to build the connection between the product’s EoL and the production of new products. Materials should be suitable to fit either in technological- or biological-cycles (as defined by the Ellen MacArthur foundation, 2012), but can also include bioplastics that can be recycled, even if they are based on materials located in both cycles. (Bocken et al., 2016; Bakker & Balkenende, 2020)

Narrowing Resource Flows

This aims at decreasing the amount of material and the number of different materials used within a product. It opens up possibilities for lightweight design that decelerates resource-use, energy consumption and more effective recycling systems. (Bocken et al., 2016; Beukers & van Hinte, 2020)

2.3.3 DESIGN STRATEGIES

80% of all product’s environmental impacts are determined in the design phase. This points at the designers’ responsibility to make choices for strategies that allow for a positive sustainable impact. (European Commission, 2012) The described resource loops and flows demand the application of dedicated design-strategies. Following the statements of Bakker et al. (2019) and Bocken et al. (2016), product life extension can comprise of several different strategies therefore, including design for:

- Attachment and trust
- Durability
- Standardization & compatibility
- Ease of maintenance & repair
- Upgradability & adaptability
- Refurbishment & remanufacturing

An underlying dimension in these strategies is the integrity of the products that are involved within, meaning the overall intactness of the original parts of the first product configuration. Looking at the list of strategies, the integrity decreases from top

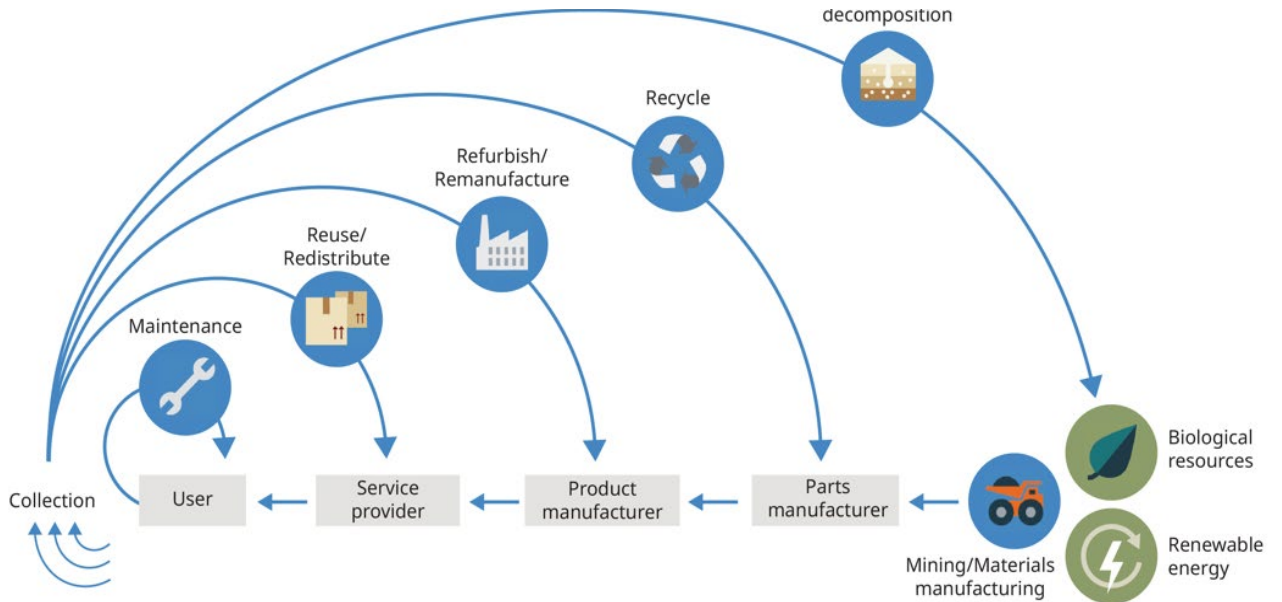

Fig. 11 – Resource flows in the Circular Economy (Bakker & Balkenende, 2020)

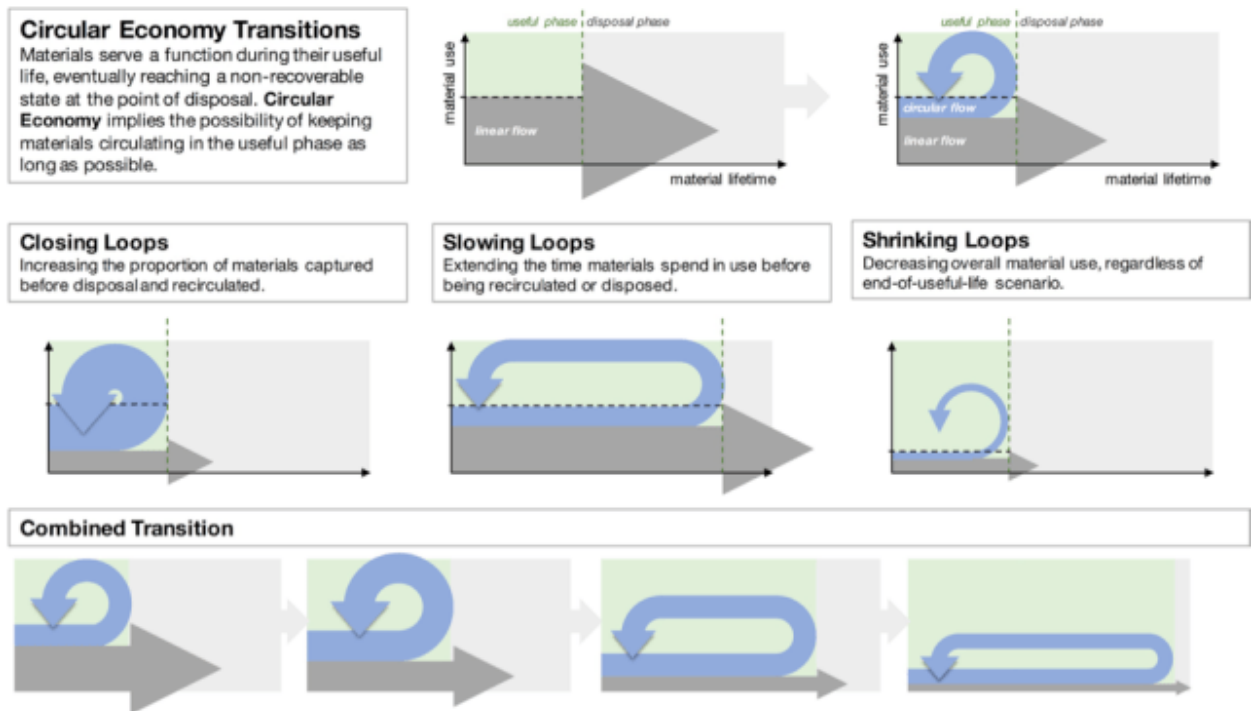

Fig. 12 – Conceptual depiction of closing, slowing and shrinking Loops. (discardstudies.com)

CONTEXT ANALYSIS

to bottom (with recycling — or worst case — energy recovery and landfill at the very end). (Bakker et al., 2016) The Ellen MacArthur foundation (2012) is also referring to the *power of the inner circles*, with the same notion of preferring the inner circles with high product integrity. Products that flow within the inner loops demand less resources and energy and are therefore ecologically and economically preferable. (Korhonen et al., 2017) Further definitions of the described loops and strategies & principles therefore are following:

Maintenance & Repair

Repair refers to setting a product back to its working state after an error occurred or it was rendered faulty or broken. Repair can be considered as corrective, whereas maintenance describes a pre-emptive and possibly scheduled process. (BS8887-2-2009 in Bakker et al., 2019; CEN/CENELEC, 2020)

Reuse

Reuse is “any operation by which products or parts thereof are used again for the same purpose for which they were conceived” as defined by the EN 45554 European Standard (CEN/CENELEC, 2020). This includes direct reuse of a product that is kept fully intact, by another user, other than the first owner. (CEN/CENELEC, 2020).

Refurbish

This describes the functional or aesthetical maintenance or repair of a product to restore it to its original state, an upgraded state or another pre-determined form of functionality. (CEN/CENELEC, 2020).

Remanufacture

Remanufacturing points towards a production process, using parts that were previously used to produce products that are supposed to be used anew. (CEN/CENELEC, 2020).

Recycle

Recycling indicates retaining value by recovery operations that reprocess waste materials into products, materials or substances, either for the original state of the product or other purposes. (Bakker et al., 2019)

Energy Recovery

Energy Recovery is referring to energy generation by incinerating waste, therefore restoring only part

of the initially embodied energy the product held. It is not considered a sustainable strategy and should be avoided.

2.3.4 DESIGN FOR EASE OF DISASSEMBLY

An intricate feature for turning the strive to slow down and close resource loops into a working scheme, is the strategy of designing products for assembly, dis- & reassembly. Ease of disassembly also plays an important role in the recycling of goods. Controlled disassembly enables the highest degree of recovery, compared to other recycling processes. However in this case, especially with using destructive connections, the disassembly could be a forceful one, with no possibility of reassembly. (Boothroyd & Alting, 1992; Jorden, 1987) The distinction between product architectures for mere disassembly and those designed for subsequent reassembly is eminent. In this case, it is important, that the product architecture can be put back into a working state, after possible assessment and replacement of parts. (Bakker et al., 2019) Design for ease of disassembly enables cost-effective operations and products that fit into the strategies of repair, refurbishment, re-manufacturing, parts reuse and recycling that are immanent in the Circular Economy. (Flipsen, 2020)

2.3.5 PRODUCT VALUE

Value Hill

The way in which value is created, changed and destroyed (or retained) facilitates a strong distinction between the Circular Economy and its linear counterpart. This main differentiation is depicted in a visualization by Achterberg, Hinfelaar & Bocken (2016) — The *Value Hill*. The Value Hill shows how value moves through the product lifecycle. (Fig. 13) Creating value through extracting resources, refining, manufacturing and assembling them into products, then shipped to customers — for them to use, or rather ‘consume’ them, is the approach of the Linear Economy. This scheme ends with the destruction of value in the post-use phase through incineration or landfill. Ultimately leading to lost value. The system can only work through companies producing more and selling faster, unsustainable so, as a finite system cannot be exploited forever. On the other side stands the

Schematic of the Circular Economy, with the aim of keeping value as long within a product as close to the usage phase as possible with processes like repair & maintenance, reuse & redistribution, refurbishment, remanufacturing and lastly, recycling.

The linear economy



with

The circular economy

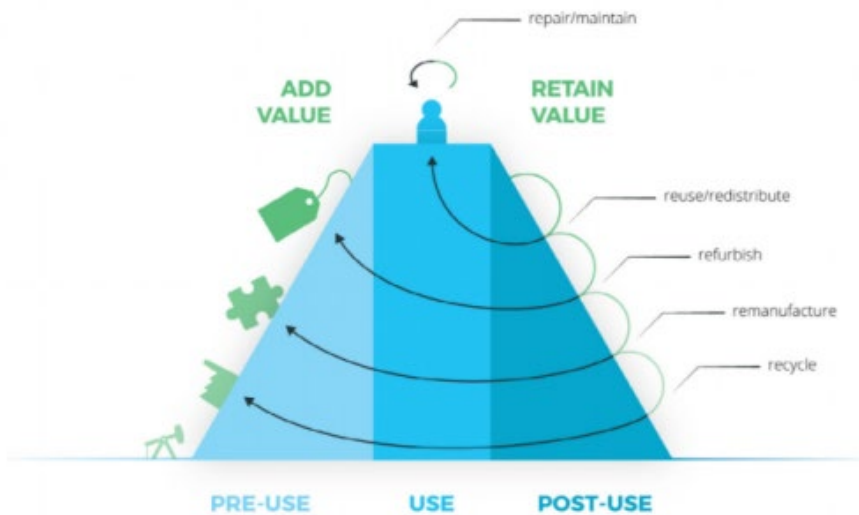

Fig. 13 — Value Hill within the Linear- & the Circular Economy (Achterberg et al., 2016)

2.4 USER BEHAVIOUR & HELMET LIFECYCLE

2.4.1 CURRENT KNOWLEDGE BASE

This project’s main focus is re-designing ski-helmets as representative products of safety-crucial products with highly functional and integrated product architectures. An important framework for this work is the user behaviour around buying, using and discarding current products.

Helmets are safety items, currently advised to be replaced after one crucial impact. However there might be different reasons why users replace their current product with a new one. There’s different suggestions on the latest point of replacement of helmets. The United States Consumer Product Safety Commission (2017) refers to five to ten years of usage until replacement. Other sources state three years, mostly recommended by helmet-brands. (O’Neill, 2018; Loria, 2020)

Next to the foam liner and the shell other parts can fail, even due to normal wear and tear or being exposed to sweat, cosmetic products or environmental influences like heat or UV radiation. This can include the shell, the retention system, fitting systems or the soft inside-padding. Other reasons for replacement could include upgrades to newer technologies or to new models with more current aesthetics. (Loria, 2020)

2.4.2 QUANTITATIVE SURVEY

Focus

Other than these sources, currently, no reliable data is available regarding the reality of usage-times of ski-helmets — especially why users replace their product and what happens to the old item. To gain better insight on these topics, a quantitative survey was conducted. This leads the focus on the secondary research questions of this thesis project:

RQ5 RQ2 What is the current time of use for ski-helmets?

- RQ5.1 RQ2.1 Why are ski-helmets discarded?
- RQ5.2 RQ2.2 What are the most often recurring failures?

The survey also aims at assessing other topics (The questionnaire can be found in Appendix K):

- General usage frequency of helmets
- Focus-points, when buying new helmets
- Current features in helmets that are prone to damages
- Importance of replacement after a crash
- User-behaviour with helmets that are no longer used
- General acceptance of sustainably-designed helmets

Process and Documentation

The survey was conducted through an online survey-program, with a combination of multiple-choice questions, Likert-scales for assessing levels of importance and interest, and open questions for qualitative answers.

The survey was conducted in English and German, it was placed in multiple interest-groups on social-networks, also in personal networks.

The results were collected in a spreadsheet-tool and analysed using statistical descriptive methods, but also qualitative collection of relevant information from the open questions.

Fig. 14 – Gender proportion of participants

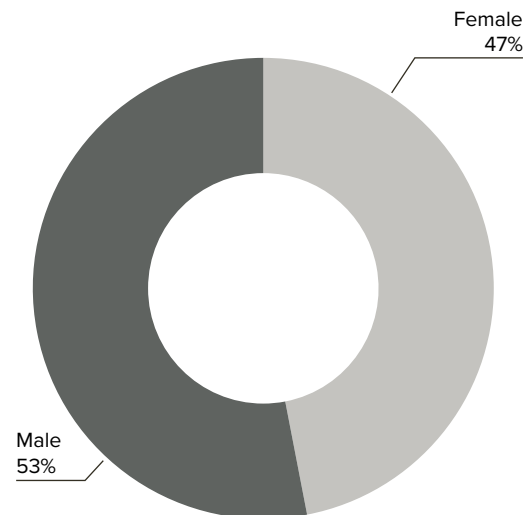

n = 230

Fig. 15 – General acceptance of helmets

Do you use a helmet in any [...] recreational activities or sports?

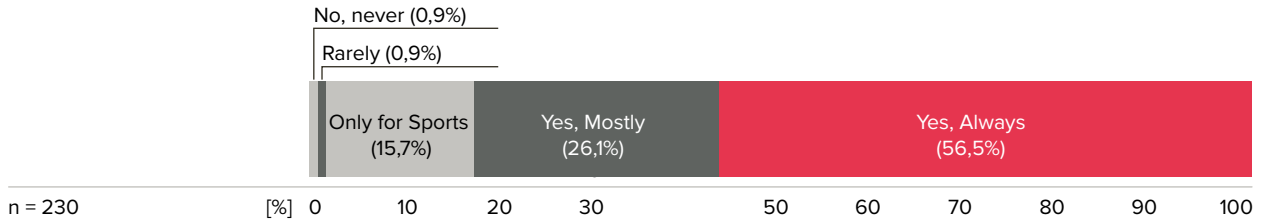

Demographics

The participants of the survey identified with the female- in 47% and the male-gender in 53% (Fig. 14). Furthermore, the average age of the participants is 43 years, with the largest age group being the group between 46 and 55 (29%), followed by 26 and 35 (25%) and 36 to 45 (20%). (Fig. 16) Lastly, 45% of the survey-participants have German-nationality, 37% Austrian and 11% are citizens of the United States. Other participants had nationalities of the countries Switzerland, Italy, the Netherlands, the United Kingdom, Poland, Belgium, Slovenia, Romania and Canada. (Fig. 17)

95% of participants identified themselves as skiers or snowboarders, 81% as users of bicycles. Other sports activities were climbing (7%), rollerblading (3%), horseriding (1%), kayaking (1%), wakeboarding (1%) and windsurfing and skateboarding with one answer each.

Results

The first question focused on the usage frequency of helmets. Generally stated, 99% of all participants at least sometimes wear helmets, only two participants stated, that they don't wear helmets – one of them answered, that he finds them bothersome (Participant #105) 56,5% always wear helmets, 26% wear them most of the time, and roughly 16% wear them when they are following sports-activities.

Fig. 16 – Participant age-groups

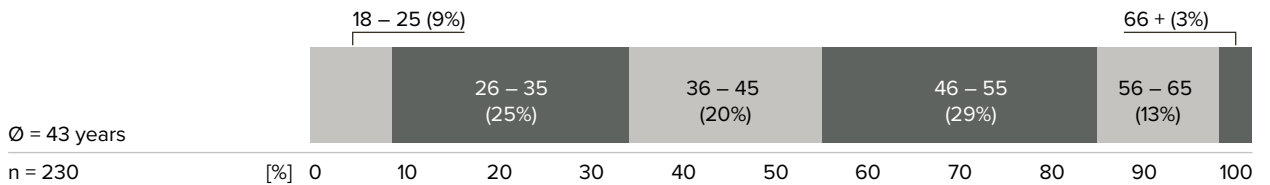
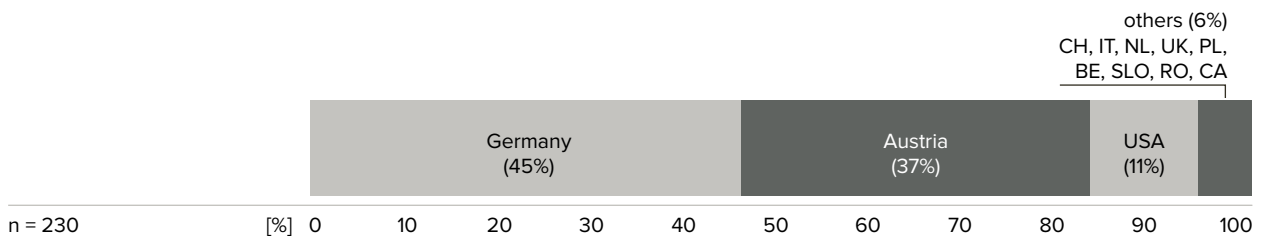

Fig. 17 – Nationality of participants



CONTEXT ANALYSIS

Fig. 18 — Key buying-factors

When you buy a new helmet — How important are the following factors for you?
(1 — Low importance / 6 — High importance)

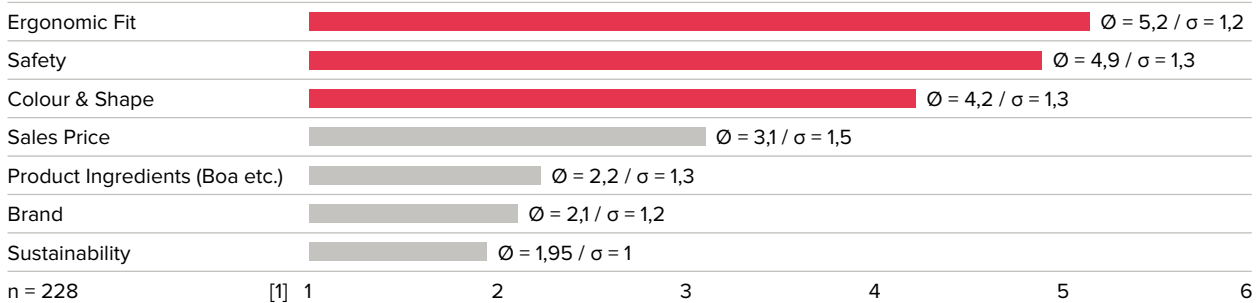

The participants were asked about their focus points, when buying a new product. Most important was the ergonomic fit, with an average of 5,2 on a six-step Likert-scale, in which one accounts for low- and six for high importance. The next properties were safety (4,9) and colour & shape (4,2). Sales price, product ingredients and brand followed in the ranking, with sustainability at the low end (1,95). 30% of participants stated, that sustainability is not important in their decision to buy, 3% assigned this question a 'very important'. Other participants also declared weight as a key factor, but also compatibility with goggles, quality indication labels, adjustable ventilation and the availability of spare-parts like paddings and brims.

If the ecological sustainability was shown in helmet-products, [this factor would be] very important' [to me].

Participant #76

This comment was made by one participant, suggesting that there is currently no clear indications of sustainability and therefore no possibility for comparison between different helmet-products.

When are helmets discarded and why?

The average time-in-use of helmets is 5,87 years. The majority of participants uses their helmets between three and five years. 30% use them between six and eight years. Fourteen percent use them even longer, between nine and ten years.

The smallest group accounts to three percent, people in this group use their helmets between one and two years. (Fig. 19)

Three percent of participants use their helmets for one or two years, Fig. 20 shows, that 65% of participants answered, that they discard their helmets when they are damaged and no longer intact. 43% discard them, because old products become obsolete, as new technologies arise. 40% discard their helmets, even as they are only worn, but still intact, which is connected to 36% of helmets being discarded because they are no longer aesthetically pleasing.

Fig. 21 visualises the answers to the question on the participant's behaviour with their helmets after their end-of-use. 76% discard their used product, damaged or still intact, 28% put them in storage and 14% pass it on to friends or relatives. Merely 7% consider reselling an option and only two percent return damaged goods.

Fig. 19 – Average time-of-use of helmets

How long do you use your helmet, until you replace it? (on average)

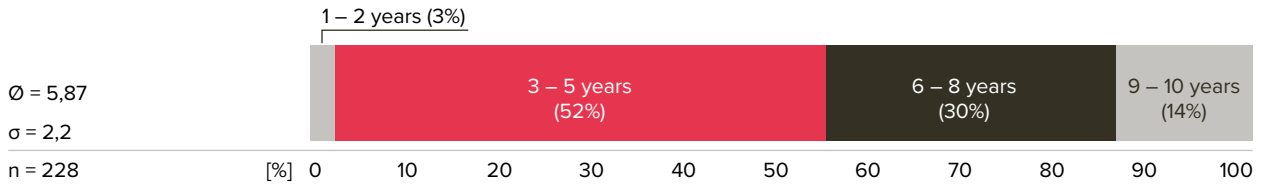

Fig. 20 – Key factors for the replacement of helmets

If you replace your old helmet with a new model, why are you making this choice? (Multiple answers possible)

The helmet is ...

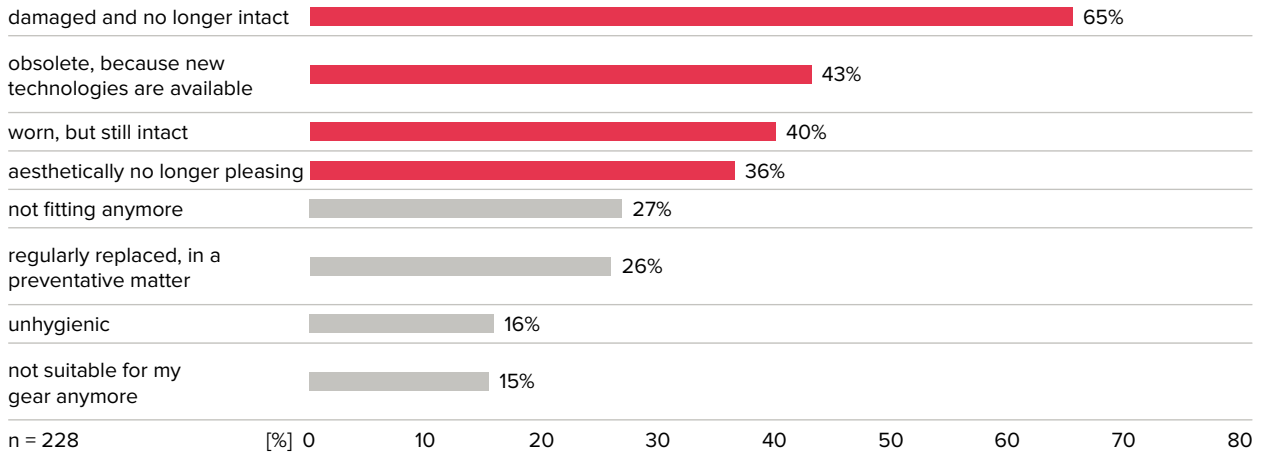
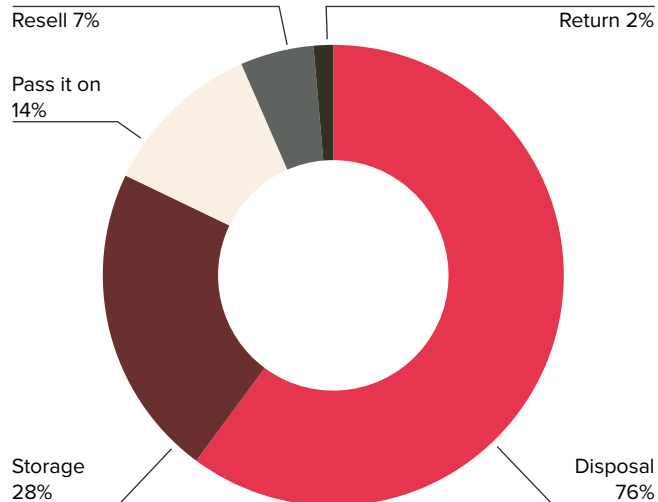

Fig. 21 – User-behaviour at the end-of-use

What do you do with old helmets, after their time of use? (Multiple answers possible)



n = 228

CONTEXT ANALYSIS

Fig. 22 — Replacement of helmets after a critical impact

How important is it to you, to replace the helmet after an impact?

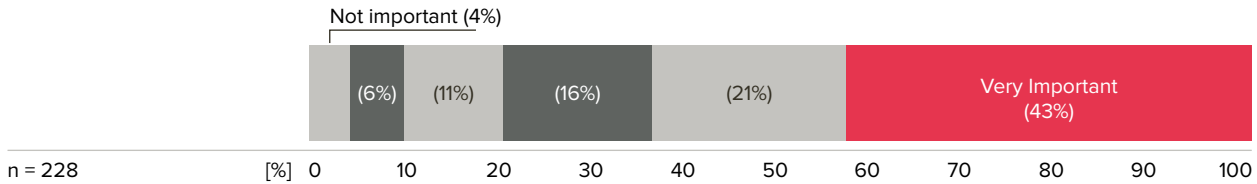

Participants were further asked about the importance of replacing helmets after critical impacts. (Fig. 22) 43% of all participants consider this ‘very important’ and only 4% see no importance in this habit.

Concerning specific parts that are prone to damages and therefore lead to the product’s discarding, survey results are visualized in Fig. 29, in chapter 3.1.

The real Importance of Sustainability

Sustainability is currently not of importance in the process of buying new ski-helmets. This can be related to larger importance of other factors in a product like this, but also, as some participants suggested, the mere absence of competitive products in this sector.

This assumption was also tested in the survey, and participants were asked about their interest in products that followed a more ecological-sustainable approach. Fig. 23 indicates, that participant’s interest in sustainable products is considerably higher than their current focus when buying helmets. Interviewees assigned this question with an average of 3,7 on a scale from one (not interesting) to six (very interesting).

Concerning the selection on the general interest in sustainable products, a follow up question was raised, asking participants to further elaborate their answer.

Some participants stated, that they already consider helmets as being sustainable, as they use it quite long. (participant #43 & 199) Others were interested in sustainability, but also liked to update their gear every few seasons (#216). Some were hesitant on sustainable sporting-goods, and there was a large rejection of the possibility of another product using ocean plastics (#183) — also going into the direction of participants #177 and 49, who stood in strong opposition against green-washing practises. Participant #49, however, was still interested in real ecological benefits.

Many participants stated, that they would be interested in sustainable solutions, yet safety, design and functionality must be top priority. If these features would be fully in place, a sustainable option, in addition, would be a key-driver in the buying-process. Some participants signalled acceptance of sustainable products and went even further — proposing service concepts to take back products (#78) and to prevent old products from sitting in storage (#224).

I don’t want to be sold yet another product made from ocean-plastics.

Participant #183

Fig. 23 – Current importance of sustainability versus interest in sustainable products.

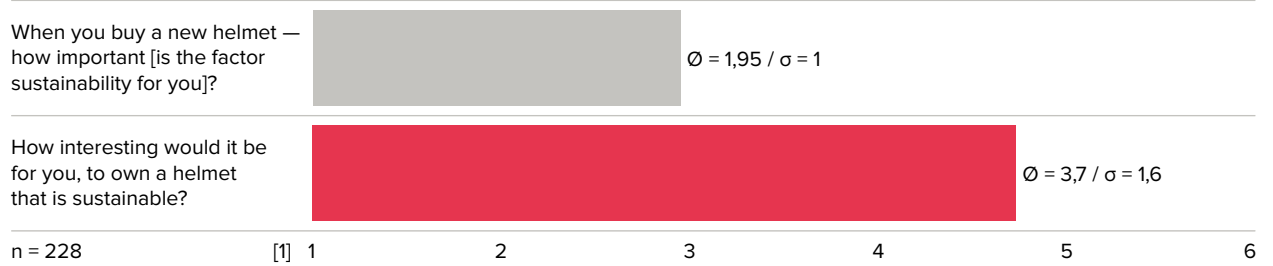

2.5 IMPACT ASSESSMENT

If helmets are fully functional is largely dependent on the structural health of parts like the EPS-core, the shell parts, chinstraps etc. Currently, it is very difficult to analyse their status from the outside, and detailed assessment would be needed — mostly involving the helmet’s full destruction, as parts cannot be disassembled in this extent.

Solutions that aim at closing this knowledge gap are available, with use cases in different industries, from monitoring impacts in the shipment of goods to sensors already implemented in helmets. These sensors measure impact-accelerations (g-forces) and are available in sensitivity ranges of up to 500G; from passive to active, from analogue to digital.

2.5.1 PASSIVE IMPACT INDICATORS

Examples for passive impact sensors are Omni-GWS (Fig. 24), Shockwatch Tube (Fig. 25) or Drop-N-Tell (Fig. 26) These sensors are triggered by acceleration forces and indicate impacts upon examination. They provide information about whether or not an impact above a certain threshold has occurred, yet not about the extent of impact forces.

The Omni-GWS provides a mechanical solution, involving springs and metal-spheres. Accelerations can be indicated up to 500G and in two

dimensions. The system works in temperatures from -73°C to 135°C. Once a threshold is reached, spheres and springs fall out of their position, yet they can be re-aligned and therefore the sensor can be reset. The current downside is the diameter of 38mm, the weight of 57g and the high pricepoint, upwards of 100€ on wholesale. (Sercalia, 2020; Conservatis, 2021)



Fig. 25 — Shockwatch tube mini impact indicator (Sercalia, 2020-b)

The Shockwatch tube sensor is an item that is advertised as tackling the problems with large dimensions of different impact sensors. It is supposed to fit into even small electric gadgets. However, currently no acceleration values, dimensions or pricepoints can be deduced, even as it is offered on different websites. Furthermore, it is a single-use sensor — once triggered, it has to be replaced. (Sercalia, 2020-b)



Fig. 24 — Omni-GWS two-dimensional passive impact sensor (Sercalia, 2020-a)



Fig. 26 — Drop-N-Tell reversible (Ströbel, 2021)

Another passive impact sensor that can be reset is the Drop-N-Tell sensor. It is a single-directional sensor that is available up to 100G (sensitivity threshold). It shows that an impact occurred through coloured indicators and can be reset by inserting a metal wire, multiple times. Analogue to the Omni-GWS, with 51mm in length, 21 in width and 7mm and depth, the dimensions are also considerably large, even as the shape is rectangular and flat. (Ströbel, 2021)

The Tozuda head impact sensor is the last example of passive indication units. It was developed to



Fig. 27 — Tozuda head impact sensor for concussion awareness (Plastics Today, 2020)

sense impact accelerations in sports helmets at a threshold of 85G, which, as the developers claim, indicates a 60% likelihood of concussions. It has dimensions of 40mm x 15mm x 15mm, weighs 8 grams and is constructed from Polycarbonate and a metal spring. The product is sold for around 40€ in wholesale. (Garcia, 2019; Tozuda, n.d.)

2.5.2 ACTIVE IMPACT ASSESSMENT

A different approach on impact assessment is the active monitoring thereof. Atomic is currently testing a sensor system called ‘Shocksense’. (Fig. 28) At this point, it is placed in a special model of Atomic’s top of the line race-helmet and is connected to an app, informing the user about accelerations that occurred. This does not only cover accelerations from crashes, but also the impact slalom-gates have on the helmet as these two items get in contact often and they also can lead to damages of the helmet.

Shocksense is an analogue three-dimensional acceleration sensor, measuring accelerations of up to 200G, sampling impacts real-time at 7kHz and communicating with the user’s smartphone through Bluetooth. The values of all three-dimensions, transmitted from the sensing unit are translated within the app into a three-dimensional impact model, indicating which areas of the helmet were subject to impacts.

The system is powered through a small battery, over a period of ca. 60 days. After this period, the battery needs to be replaced.



Fig. 28 — Atomic Shocksense active impact sensor





3 ASSESSMENT OF CURRENT SKI-HELMETS

Ski-helmets were analysed on possible hotspots within their architecture concerning impact, value and indicators for their ease of disassembly. Safety crucial parts and parts with crucial perceived value were defined and integrated into the analysis.

3.1 PRIORITY PARTS 38

Functional Priorities
Failure Probability
Crucial Value Perception
Priority Parts

3.2 ASSESSMENT SETUP 42

3.3 HOTSPOT ANALYSIS 46

Disassembly Steps and Tasks
Disassembly Time
Tools & Fasteners
Hotspots

3.4 DISASSEMBLY MAPS 50

Structure
Connection to HotSpot-Mapping
Results

3.5 ECOLOGICAL IMPACT & ECONOMIC VALUE 66

Current Impact
Materials in Use
Inseparable Components
Impact of Materials and Compounds
Impact of Priority Parts

3.1 PRIORITY PARTS

The fit of ski-helmets into the Circular Economy is dependent on the identification of priority parts. This includes parts that are either of high functional importance or have an above average probability for failures. These attributes, and the parts connected to them, have been analysed in preparation for the following product assessments (Chapter 3.2 - 3.5) and for decisions for re-design, following from chapter 5.

3.1.1 FUNCTIONAL PRIORITIES

Ski-helmets, and helmets in general can be defined by catering to three different kinds of functions:

- Safety critical function
- Ergonomic function
- Aesthetic function

These functions are connected to different parts of the product, yet some parts can be responsible for multiple different functions, however they are placed in the main-category which they belong to.

Safety critical function

The main functionality of helmets is their energy-management capabilities, designed to protect their users in the event of an impact to the head. As previously described in chapter 2.1, components within this category are responsible for transforming the impact energy (shell and liner) and prevent penetration by sharp or pointy objects (shell), but also ensuring the proper fixation on the user's head (chinstrap and retainer system).

Although not specifically regulated, fit also plays an intricate role in the safety crucial functionality of helmets. Therefore the main functional priority also includes these elements.

All parts with safety critical functionality are parts that are necessary to use the product in a safe way, and their intactness is therefore inextricably linked to the product's usability.

Ergonomic function

Whereas failures in safety critical function parts will render the helmet useless in its core-function, failures in parts with an ergonomic function can still leave the product functionally sound, yet

provide discomfort and decreased usability to the user. These elements within helmets are mostly textile-liners and paddings, in place to provide wearing comfort. Goggle retainers and visors, but also ventilation systems are furthermore included in this category.

Aesthetic function

Ski-helmets, as they are designed with a specific focus on safety and ergonomics don't have many components with a pure aesthetic function. Elements belonging to this category are mainly decorative stickers and badges, showing information about brand, model or product ingredients, but also purely graphic, styling orientated elements. These parts have no impact on functionality and the perception of usability.

3.1.2 FAILURE PROBABILITY

Failure due to critical impact

Current ski-helmets are considered a single-impact item. Once they were involved in a critical impact scenario and provided their function, they need to be replaced — as is the suggestion regarding all current ski-helmets. This is mostly related to the EPS-liner and the outside-shell, as they can deform due to the high energies in an impact. Failures can also occur in the retainer system.

The results of the survey conducted in chapter 2.4 refer to an average time between the purchase and the replacement of sports helmets of 5,85 years (n=230). This number allows the estimation, that these critical impacts only rarely happen in proportion to the general population. Therefore it can be concluded, that ski-helmets are prone to critical-failures, yet they don't occur that often.

Failure due to wear and tear

Other than the previously described extreme forms of functional errors, normal forms of usage lead to certain forms of deterioration on a regular basis. The elements closest to the user are most likely to show these signs of wear. 114 participants in the survey stated, that they witnessed damages of the helmet's soft-padding. (Fig. 29) This can also be true to the chinstrap webbing, with

78 participants noting this item as being prone to damages. Hereby, the wearing process is related to sweat, sunscreen and other skin-care products acting on the material.

Furthermore, shell elements can wear over time. 71 survey participants discovered damages with these elements. The parts can be scratched from usage, storage and transportation and other damages like softening of the paint can occur:

“I replace my old helmet with a new model because the outer-shell becomes sticky.”
(survey participant #37)

In more extreme, yet isolated cases of continuous wear and tear, the shell can come off from the EPS-liner. (survey participant #132) This is a damage that makes the product unusable.

Damages from normal wear and tear can also be found in the fitting-system, chin-buckle and ventilation adjustment sliders. These parts can either break mechanically and loose their functionality, but also can deteriorate due to continuous adjustment, which would affect their perceived quality and not their function.

3.1.3 CRUCIAL VALUE PERCEPTION

As helmets are used in close proximity to the user, the perceived product integrity is important for users deciding between keeping or replacing the product. Like previously stated, this is especially the case for parts closest to the user, like paddings and textiles that can deteriorate over time, and even develop unsightly stains or colour changes from skin-care products, etc. The same perceived quality is also true to exterior parts, like scratched shells and parts that wear from continuous adjustment, like chinstrap buckles, fitting system toggles or ventilation sliders.

The perceived product integrity is also important in product lifetime extensions like refurbishment or repair. Certain elements are more visible than others and signs of wear and tear can lead to users refraining from purchasing or using these, even as the main functions — safety and ergonomic fit — might still be fully intact.

As the current version of the HotSpot-Mapping tool provides space for an extra requirement, next to failure frequency and the functionality indicator, the perceived product integrity should be defined as extra requirement to give stronger emphasis to this.

Fig. 29 – Common damages

With which of the following components did you experience any damages during your helmet’s time of use?
(Multiple answers possible)

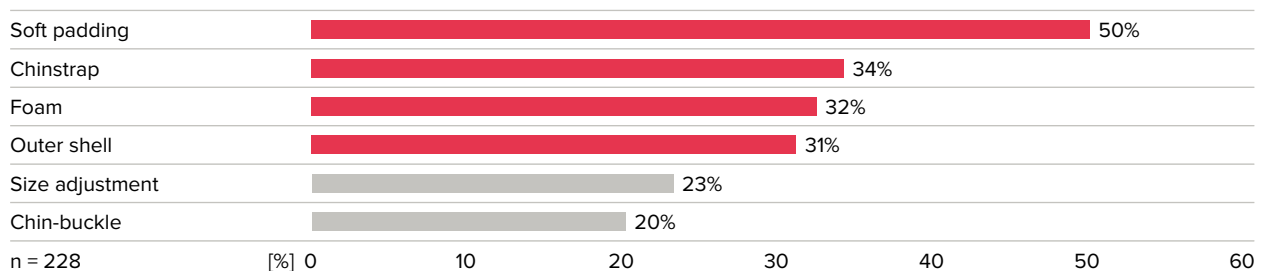

ASSESSMENT OF CURRENT SKI-HELMETS

3.1.4 PRIORITY PARTS

The following product analyses, focusing on the environmental and economic impact of the different parts, and the disassembly process involved in taking them apart, demands the definition of a hierarchy following the importance of specific parts.

The different functional priorities are defined as:

- Safety critical function
- Ergonomic function
- Frequent failures
- Perceived quality

Tab. 1 shows these different priorities. Parts with more priority indicators are located higher up in the priority hierarchy. Parts marked with (X) mean, that only parts of the compound are considered as a priority.

Tab. 1 – Priority Parts
 Priorities in different sections,
 from safety critical functionality
 to the parts crucial value
 perception

Part Name	Safety critical function	Ergonomic Function	Crucial Value Perception	Frequent Failures
Foam liner (EPS)	X	X		X
Shell	X		X	X
Chinstrap	X	X	X	X
Chinstrap fixations	X			
In-mold fixations	X	X		
Buckle	X	X	X	
Oblique-impact system	X	X		
Fitting mechanism	X	X	(X)	X
Fitting headband	X	X		
Soft liner		X	X	X
Chinstrap pad		X	X	X
Earpads		X	X	X
Goggle retainer		X	X	X
Visor		X	X	X
Ventilation system		X	(X)	

3.2 ASSESSMENT SETUP

As previously stated, many strategies of the Circular Economy demand the re-designing of products for the ease of disassembly. Before decisions on re-design can be made, current products have to be assessed on their current disassembly-performance. To base design decisions on an informed knowledge, assessment methods for disassembly were developed from the 1990’s on and are following ongoing processes of modernization. Two current tools, used for assessment and visualization of disassembly-structures within this thesis project are the HotSpot Mapping method (Flipsen et al. 2020) and the Disassembly Map. (De Fazio, 2020; Vermaat, 2020) These tools were used to analyse and build a comparison-basis for benchmark products.

Products

Five ski-helmets were analysed concerning their ease of disassembly — Three helmets, intended for the use with external glasses or goggles, and two with integrated visors. The products were chosen because of their representation of current products on the market and because they incor-

porate different product-features and production methods. The selection includes in-mold-, hard-shell- and hybrid-helmets, it also includes products with third-party features like Boa fitting-systems or MIPS for multi-directional impact scenarios — but also proprietary counterparts of these product-ingredients. The different products are depicted, next to further information, in figure Fig. 30.

Assessment Method

The analysis of the ease of disassembly of the previously described products follows the HotSpot Mapping method. The HotSpot Mapping method, developed by Bas Flipsen is a further improvement of a selection of methods, namely developments within the standards EN45554:2020 and EN45555:2019. The first defines a method with a definition and ranking system following parts that are likely to undergo replacement or upgrading, the suitability of such parts for reuse and the main functionality of the components. The latter focused more on the recyclability and recoverability rate of products and their components within processes of recycling and recovery. The limitations

Fig. 30. — Disassembly Analysis Products



BRAND	ATOMIC	HEAD
MODEL	SAVOR GT AMID VISOR	RACHEL
Helmet Build	Hybrid — Top-Shell ABS Hardshell / Bottom PC In-Mold	PC In-Mold
Features (Fit / Safety / etc.)	Proprietary — AMID & Life-Fit	BOA Fitting System
Retail Price	300 €	200 €
Assessed Size	59-63 (Size L)	59-63 (Size L)

of these two standards were defined as the lack of acknowledgement to avoid production of primary material and the possible EoL potential of product components. (Flipsen et al. 2020)

The HotSpot Mapping method (Flipsen, 2020) focuses on critical parts within a product assembly, with interest in priority parts, necessary for functionality and maintenance and valuable parts that possess economic value or embodied environmental impact. The method is based on a spreadsheet-program, recording general part-properties, like name, the part's status as sub-assembly or belonging to other subassemblies, its material and weight.

Next, all activity properties are recorded, related to steps or activities in the disassembly process. This includes the type of activity, the used tool, task frequency and the time needed for disconnection. Further task-related information is recorded to document difficulty of access, including needed force, the ad hoc accessibility and the needed precision of positioning.

Furthermore, every part's functional sensitivity is recorded, with specific decisions made for this specific product. For maintenance, this follows the results of the conducted survey and the main function of the safety-crucial item — one critical crash can render the product obsolete. All elements in direct contact with the user (padding,

textile straps, etc.) and all safety-crucial parts were assigned that these 'wear during use'. Considering the product's long average lifetime of 5,87 years, no parts were assigned a high chance of breaking.

The functionality-rating follows the functional priorities of the product. Safety crucial elements (also including elements ensuring proper fit) are rated as 'main functional elements'. Elements connected with ergonomics are rated as 'sub-functional' and all elements connected to being purely aesthetic are assigned 'no-to-low functionality'.

Lastly, an extra requirement was established for parts that are connected to visual or emotional failures, like scratches on the helmet's shell or unsightly textile parts.

After this documentation, the method highlights the following 'hotspot indicators':

- Time needed for disconnecting parts
- Difficulty of access
- Failure rate and / or maintenance need (Priority Part)
- The part's embodied environmental impact
- The part's economic value

Disassembly Process

The assessed items were disassembled step-by-step, in the order of which they became accessible. As this thesis project's approach lies on keeping the product integrity as intact as possible,



ATOMIC	SMITH	POC
SAVOR AMID	VANTAGE MIPS	FORNIX SPIN
ABS Hardshell	Hybrid — Top-Shell ABS Hardshell / Bottom PC In-Mold	PC In-Mold
Proprietary — AMID & Life-Fit	MIPS / Koroyd / BOA Fitting System	Proprietary — SPIN Multi-Directional Impact System
130 €	260 €	180€
59-63 (Size L)	51-55 (Size S)	55-58 (Size M-L)

ASSESSMENT OF CURRENT SKI-HELMETS

the approach only includes reversible — non destructive — disassembly. However, in some products non-reversible methods had to be used to access crucial points in the assembly. In general, all products were disassembled to a point where no further components could be separated.

Throughout some of these products, there were possible shortcuts in the order of disassembly, mostly through textiles or thin plastics that could be pushed out of the way. If these shortcuts led to a steep increase of difficulty of access, precision or force needed, the ‘original’ order was continued and the shortcut remained unused.

Documentation

All disconnected parts were weighed and catalogued, documenting their name, weight and material. If the specific materiality of a part was not known, the materiality of a similar part with known specifications was used as a substitute.

A DSLR Camera placed on a tripod with remote controlled shutter was used to document the disassembly process in high-resolution detail. For the possibility to later come back on the real-time process to document real disassembly times etc., a smartphone camera was used to film the process from a different angle.

Following the disassembly process, the gathered information from photos, videos and the part-documentation was compiled in HotSpot Mapping spreadsheets. (Appendix G) As suggested in the HotSpot Mapping user guide (Flipsen, 2020), the process was put into a first visualization on the platform Miro. (miro.com)

Next, all disassembly-related results and the outcomes of the HotSpot Mapping spreadsheet were visualised in the Disassembly Map (DeFazio, 2019) with considerations of suggestions of improvement and minor changes by Vermaat (2020). The depicted priority parts are defined by the author in chapter 3.1, and the outcome of the HotSpot Mapping tool. The resulting visualisations can be found in chapter 3.4.

Lastly, all relevant data was put into Bill of Materials for every product (Appendix F), these were used to create Fast-Track Life Cycle Assessment Analyses for the products, to gather information on their ecological footprint (CO₂) and their embedded Energy (J). CES EduPack 2019 was used for this assessment, the results can be found in chapter 3.5.

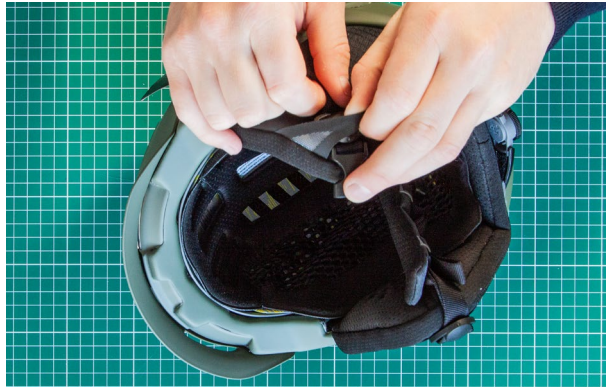

Fig. 31 — Pull chinstrap through textile strap

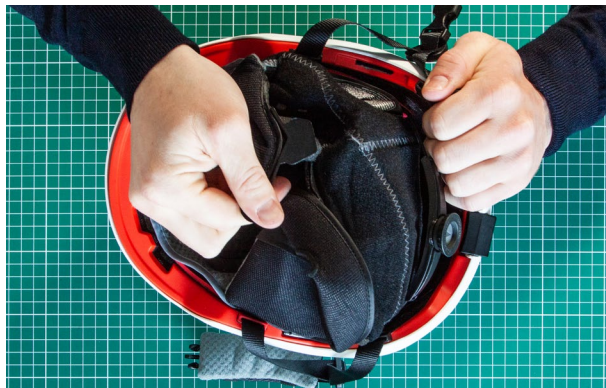

Fig. 32 — Remove soft-liner and earpads

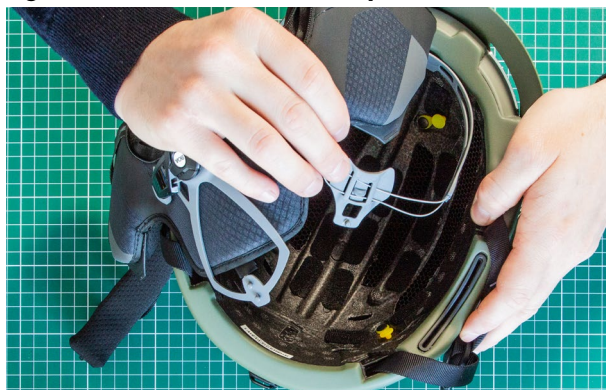

Fig. 33 — Remove fitting-system



Fig. 34 — Remove inside parts



Fig. 35 – Remove chinstrap



Fig. 36 – Unscrew goggle-retainer



Fig. 37 – Remove top-shell



Fig. 38 – Remove visor

Tools

The following tools were used for the disassembly of the previously stated products:

- Diagonal cutters
- Half-round nose pliers
- Metal spudger pry tool
- Hexagon socket keys (Allen keys)
- Screwdrivers for cross-recessed heads (Philips & Pozidriv)
- Utility knife with snap-off blades
- Scissors
- Tweezers

Disassembly Sequence

First, an underlying common disassembly sequence in the analysed products was discovered, however slight differences are in place between products. Many tasks can be facilitated already in the upper layers of assembly, although fully removing parts is often only possible after going further into the assembly.

In general, the process includes opening the chinstrap buckle (FFig. 31), and pulling the two sides of the chinstrap through the holding straps on the earpads. After this, the soft-liner can be removed. (Fig. 32) Following this, parts located on the inside can be removed, this includes parts responsible for multi-directional impact management (Fig. 34), but also the fitting system. (Fig. 33). Next, the chinstraps can be removed and disassembled. The soft liner can also obstruct access to parts like the goggle-retainer, in some products these can be also accessed solely from the outside (Fig. 36). In some builds, precisely hybrid constructions with top-shells are constructed as ABS hardshells. (Fig. 37) In visor-models, these parts can also be reached from the outside. (Fig. 38)

3.3 HOTSPOT ANALYSIS

3.2.1 DISASSEMBLY STEPS AND TASKS

The five analyzed products differentiate firstly in number of different parts: From the Atomic Savor AMID with 34 different parts and 68 parts in total to the Smith Vantage MIPS with 52 different parts and 126 parts in total.

These amounts also give a first impression on the number of steps and tasks, needed for the disassembly. Steps describe different actions followed in the disassembly process, whereas total tasks are a product of all steps and the repetition of these, in order to remove multiple parts in one single step.

Fig. 39 and Fig. 40 indicates, that the Smith Vantage MIPS helmet, with its large number of parts also has the highest number of steps (58) and needed tasks (139) to disassemble it fully. The Atomic Savor AMID, which has the lowest number of total parts also shows the lowest number of different steps (39), however, with 73 tasks, it is positioned only in the mid-field. Considering this, the lowest number of total tasks is set with 64 by the POC Fornix SPIN helmet, closely followed by the Head Rachel model with 66 total tasks.

Considering these numbers — as derived from the HotSpot Mapping tool — they give a first impression on the product architecture of the assessed items, yet no insights on their disassembly depth and the specific disassembly sequences. This insight will be given in the Disassembly Maps (chapter 3.4)

3.2.2 DISASSEMBLY TIME

The time needed to disassemble the different products does not correlate with the number of components in the assessed products — within this selection. The shortest disassembly-time, with 276 seconds, was measured in the Atomic Savor GT AMID Visor helmet. (figure Fig. 41) The longest duration, and this stands in diametrical opposition to the product's low number of parts, was found in the Atomic Savor AMID (529 seconds). However, this number is only due to the fact, that in this product the full ABS hardshell was removed — this

process alone took 300 seconds. A process that was not possible in the other products and was therefore not facilitated. A limitation to this is also, that the analyzed product, the Atomic Savor AMID, was received as a sample from the company, with an already partially loose shell, which made the process possible. This might not be realistically done in a store-bought product. Besides this, the Smith Vantage MIPS has the second-longest disassembly time, with 398 seconds.

3.2.3 TOOLS & FASTENERS

The range of tools needed to disassemble the items ranges from three, in the Head Rachel helmet, to seven in the Atomic Savor GT AMID Visor and the Smith Vantage MIPS helmets, apart from the disassembler's hands. (figure Fig. 42)

Most connections could be loosened without the use of tools, such as hook and loop fasteners (velcro) and glued parts (based on double-sided tape) which could be accessed easily by hand or fingernails. Hands and fingers were also usable for the opening of push-buttons, exclusively in use for opening the chinstrap. Fixations located on the chinstrap, like side dividers and buckles could also be loosened by the use of hands only.

A number of snap-joints, like parts locked within in-molded snap-baskets, where enough space was available could also be manipulated by hand. Furthermore, friction-fitted parts, like ear-pads, which are placed in large in-molded baskets could be removed in this same approach.

A lever / prybar-tool in form of a metal spudger was used as allround tool, especially for opening snap-joints, which were hardly reachable by hand. It was also used to remove items that couldn't be reached by hand, like tiny mechanical parts in Boa-fitting systems (Fig. 43) or stainless-steel pins that were placed in an obstructed way. It was further used for peeling off stickers or elements based on double sided tape, like foam elements, decorative stickers or velcro-strips.

Some parts were removable by using screwdrivers — Namely cross-recessed screwdrivers like Philips or Pozidriv and also hexagon socket keys (Allen keys).

Fig. 39 – Number of different steps
The different steps needed to fully disassemble the product.

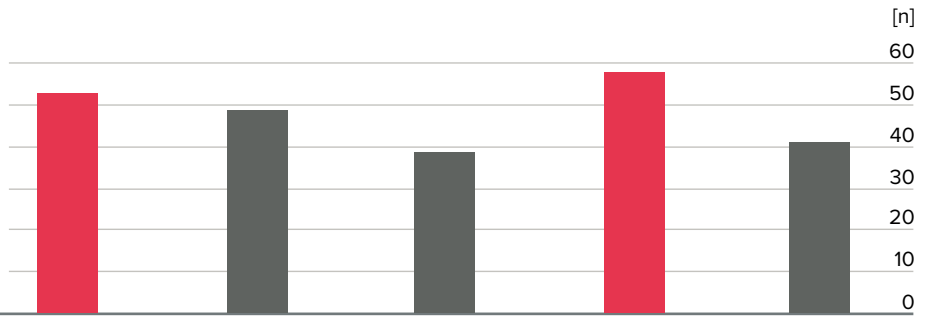

Fig. 40 – Total number of tasks
The total number of individual tasks, including repetition of similar tasks.

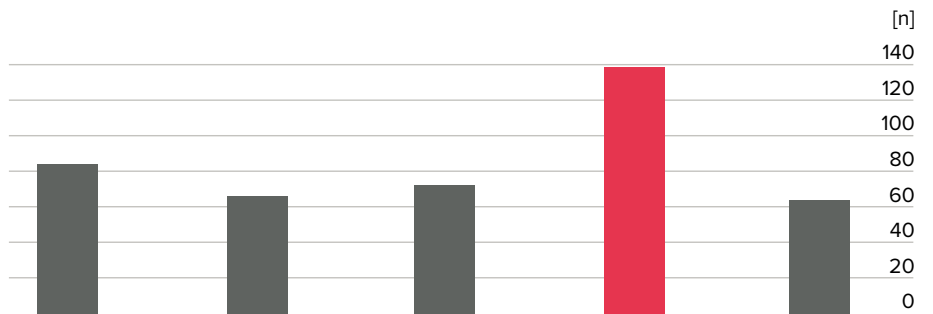

Fig. 41 – Disassembly time
The total time needed to disassemble the product.

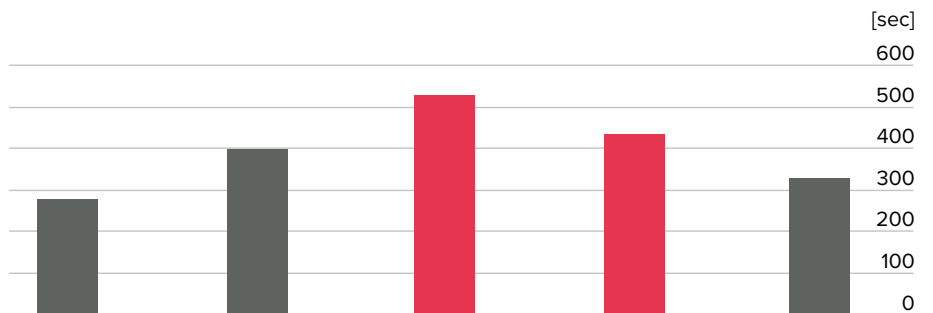
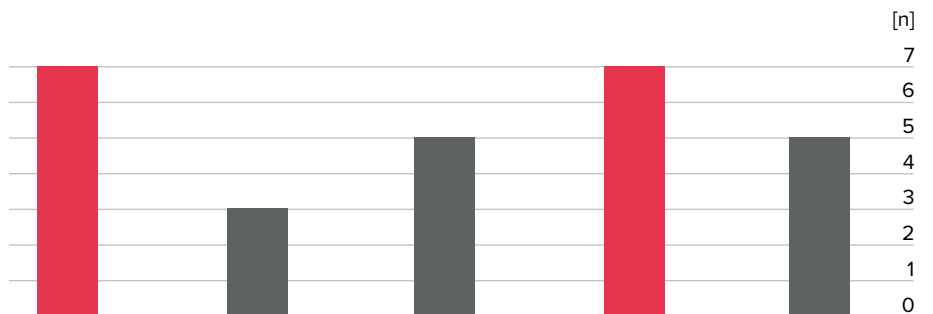

Fig. 42 – Number of tools
The number of different tools needed to disassemble the product, not considering hands.



Brand	Atomic	Head	Atomic	Smith	POC
Model	Savor GT AMID Visor	Rachel	Savor AMID	Vantage MIPS	Fornix SPIN

ASSESSMENT OF CURRENT SKI-HELMETS

Pliers were used in different forms: Half-round nose pliers were used to extend the ends of chinstrap from in-molded baskets, followed by removing stainless-steel pins who are there for form-fit-connection; Diagonal cutters were used to make precise cuts, like removing the ends of Boa-cables, to make them removable from the inside-disk of Boa-systems; Tweezers were used to remove tiny parts.

Scissors were used in the special case of the helmet model by POC, which followed a different approach on fixation and had to be cut open in two positions to give access to the chinstrap's other parts.

A utility knife was used to open threads and remove the male-hooks from the two Atomic models' soft-liners. It was also used to remove the EPS-piece, fixating the ventilation system of the POC helmet.

Textiles are also in place to facilitate fits, like soft liners holding fitting systems in place (Fig. 44), elastic-strings being fixated through knots, before going to the outside of the helmet to hold goggles in place — or even tying the whole visor unit to the helmet.

A special kind of form-fit solution is the in-mold construction, all analysed helmets use. In this case, this turns the removal of elements into a task that is fully destructive and of uneconomic duration. Therefore, this process was not undergone in the analysis.

3.2.4 HOTSPOTS

The HotSpot-Mapping spreadsheet tool indicates hotspots, or point of interests, including disassembly time, difficulty of activities and the environmental impact and economic value of the product's components.

Time-HotSpots

The hotspot-indicator for time was commonly plotted for removing the chinstrap pins and pulling the chinstrap through the side-dividers. It was also commonly in place when small pieces of velcro or stickers had to be removed in high numbers, also counting the AMID foampads and large glued-pieces. Individual activities with a long duration were the removal of the visor in the Head Rachel model, even as this function is marketed as quick release (Head, 2021; Fig. 45) — this finding can of course be due to a faulty mechanism in

a single product. Furthermore this includes the removal of the hardshell in the Atomic Savor AMID and the removal of the EPS piece covering the ventilation disk in the POC model. (Fig. 46)

Activity-HotSpots

These two parts were also marked with activity-hotspots. Other Activity-Hotspots were assigned for tasks like removing the main pin of the Boa-system and to remove the base POM-ring of the Boa-system. Furthermore removing chinstrap pins, but also for removing the stainless-steel ventilation holders (ten pieces) with the help of pliers in the Smith model and loosening the friction-fit earpad hooks in the Atomic models, as large force and a precise movement is needed to facilitate the disconnection.

Priority-HotSpots

Priority-Hotspots, as defined in chapter 3.1, are marked throughout all products as safety critical parts, like the EPS-liner, outer shells and the bottom ring, and also the safety-critical retainer parts like the chinstrap-webbing and the buckle. Hygiene-critical parts, prone to fast wear-and-tear and optical degradation were also flagged, like soft-liners, earpads and chin-fabrics. Lastly, fixation elements, in close contact with the user, like toggles, etc. were also marked.

Environmental & Economic HotSpots

Hotspots for the environmental impact (CO₂ equivalent) and the economic value of materials were found throughout all products. Collectively, this refers to parts like soft-liners, the outer shells and bottom rings, but also for the EPS-liners. In helmets with integrated visors, the transparent Polycarbonate elements are also indicated as parts with large environmental footprint. The same goes for parts like MIPS domes and other larger parts made from thermoformed PC, e.g. in fitting-system headrings. It can be concluded, that the HotSpot-Mapping tool assigns hotspots from analysing materiality and weight, which puts the focus on heavy parts in the assembly (if no parts of high-impact or -value material are included).



Fig. 43 – Using a metal spudger to remove BOA-pin



Fig. 44 – Textile form-fit around fitting-system



Fig. 45 – Visor-removal with help of a metal spudger



Fig. 46 – Removal of the EPS-disk to remove ventilation

3.4 DISASSEMBLY MAPS

The Disassembly Map tool was developed to visualize the structure of product's disassembly structures and to pinpoint the location of critical parts within the product-architecture. It was developed within a thesis-project of Francesco de Fazio (2019), in collaboration with the company Philips and was further improved by de Fazio (2020) and Bente Vermaat (2020), in a related thesis-project.

It is a tool that aims at giving a quick overview about all important information about the process of disassembling a product — from different tasks to perform, the tools needed and the sequence in which these tasks need to be carried out. The Disassembly Map enables a quick overview about the location of priority-parts within the assembly-tree and also about components with high economic value or environmental impact. Furthermore, the visual approach also enables the comparison of different products, their disassembly process and the layout of their assembly (linear and parallel sequences).

3.3.1 STRUCTURE

Building blocks

The main elements of the Disassembly Map are parts and activities. Parts are indicated through a grey circle (light or dark grey), containing a part identification, connected to a Bill of Materials. Activities are labelled through long rectangular shapes with rounded edges and contain information about type of fastener, tool used and number of tasks to perform. These labels are connected through lines between two or more tasks. (DeFazio, 2019).

Further illustration can be found in Fig. 47. Normal parts, without any priority are marked with light-grey, circular labels (1). Priority-parts are labelled with a light-grey circle with a bright-red outline (2). If parts can be removed in form of a subassembly, this subassembly is labelled through a dark-grey circle. (3)

Activities, as shown in number (4), give insight into which kind of activity is used to remove the part, the tool used and the number of single actions involved. The different tool-types are illustrated by labels in different colours and in abbrevi-

ations in brackets. The type of fastener is indicated next to the brackets. Information on used abbreviations can be found in adjacent legends. In the example (4), two snapfits were removed by the usage of hands to access part A. Furthermore, it is possible that multiple different activities are necessary, in sequence, to remove a single part.

Priorities in safety crucial parts and parts with crucial value perception are labelled through this symbol.

Sequences

The Disassembly Map makes use of two different sequences: Linear and parallel sequences. In linear sequences (5), parts have to be removed in one single order, e.g. part A has to be removed before priority-part B can be removed. In parallel sequences (6), two parts can be removed in any order. As in the example, priority-part A or priority-part B can be removed in any order, if no further requirements are in place.

As improvement on previous versions of the tool, the depth-levels of the Disassembly Map are now based on a constant grid, along all assessed products for improved comparability. (DeFazio, 2020)

And/or relationships

Parallel sequences can be in place, with the requirement to remove two parts, located in parallels to access a part located below. This is described as an 'and'-relationship. The difference to the logic stated in the previous example — the 'or'-logic, is that it is absolutely necessary to remove both parts. However, the similarity is that there is no specific order in which these parts need to be removed. As shown in example (7), an 'or'-relationship indicates two accessible parts, A & B, which need to be removed to fulfil a following 'and'-relationship to remove priority-part C.

Subassemblies

Some parts can be removed as part of a subassembly (a compound of parts still in connection after removal from the main assembly). In this case, the subassembly can be removed from the main assembly in one piece, with the possibility to further disassemble the compound later, or

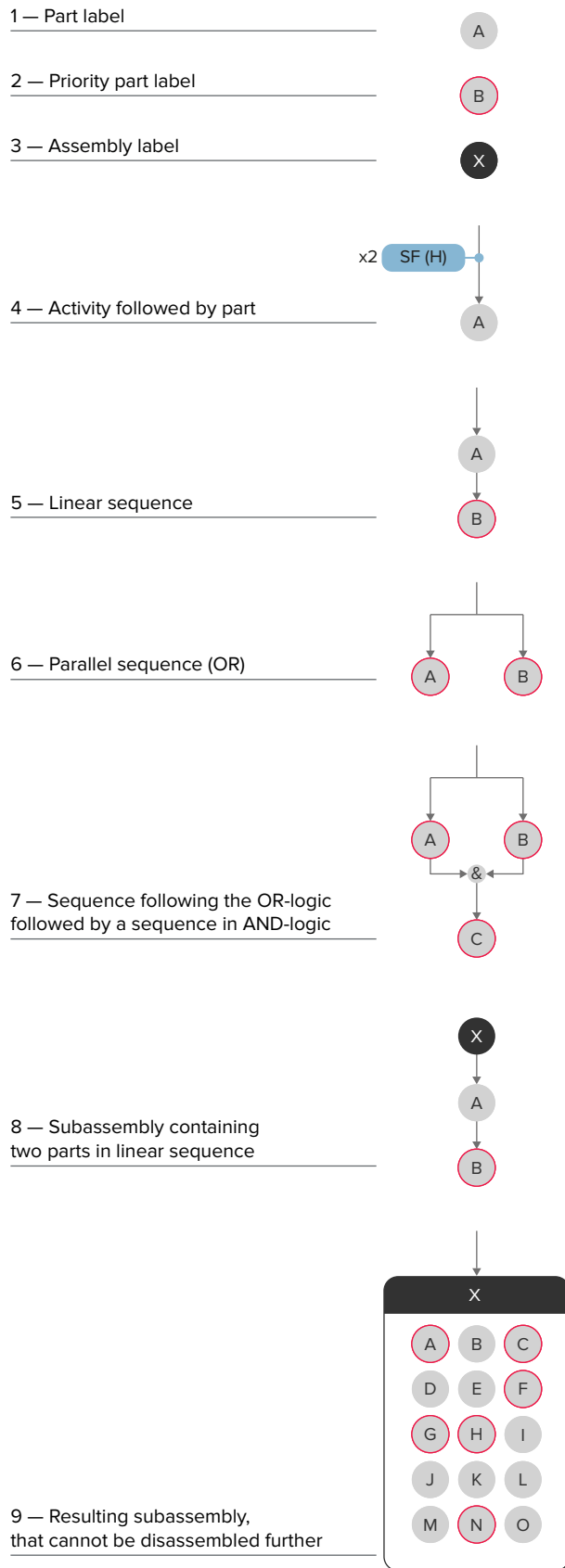

Fig. 47 — Structure and logic of the Disassembly Map
 An illustrative example, showing the functioning of the Disassembly-maps and how to read them.

ASSESSMENT OF CURRENT SKI-HELMETS

further access the main assembly. In example (8), subassembly X can be removed, which then gives access to parts A and B, in a linear approach.

Inseparable Subassemblies

In some cases, parts cannot be taken further apart, which is caused by fixations destroyed once opened. These inseparable collections of parts are referred to as resulting subassemblies, which are labelled with a subassembly index-letter, and individual part- & priority-part labels within the subassembly. In example (9), resulting subassembly X includes parts A to O, out of which six parts are considered priority-parts.

3.3.2 CONNECTION TO HOTSPOT-MAPPING

Within this thesis-project, the Disassembly Map tool was used in close connection with the HotSpot Mapping tool. Next to the sequence and structure visualized in the Disassembly Map, HotSpot Mapping provides information about activities, tools and the number of tasks performed. Furthermore, it provides information on the difficulties of the undergone tasks performed and other hotspots concerning parts and their weight and materiality. This information is shown as circular labels, with a single corner, in the Disassembly Map, to further give overview about relevant information concerning the product's disassembly.

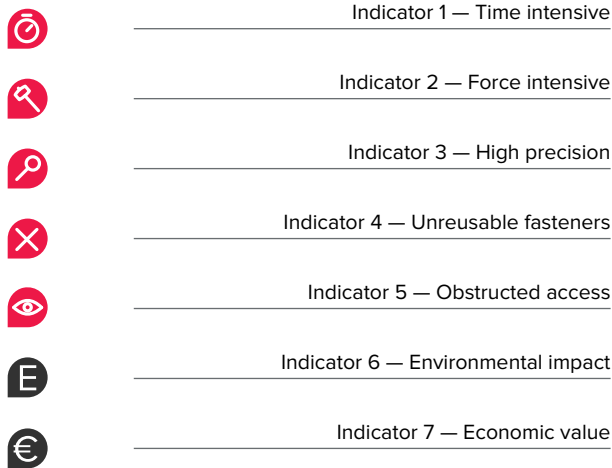

Fig. 48 — Activity and part-priority indicators

Indicators considering the parts removal and part indicators

(Fig. 48) Analogue to the HotSpot Mapping tool, indicators in the Disassembly Map follow red-flags in different priority sections, if not stated differently. Red-flags mark the 90th percentile of parts and activities, in their respective section. (Flipsen, 2020)

Activity indicators

These indicators (1 – 5), shown as bright-red labels, describe difficulties with certain tasks performed and focus on multiple different properties.

- (1) Time intensive: Indicator labelling activities analogue to the red-flagged time-hotspots in the HotSpot Mapping tool. (Appendix G)
- (2) Force intensive: Marking activities with the selection 'heavy resistance' in the HotSpot Mapping tool.
- (3) High precision: Activities with the selection 'high precision' in the HotSpot Map.
- (4) Unreusable fasteners: Fixations that were only removable in a destructive way, and therefore could not be reused for re-assembly.
- (5) Obstructed access: This indicator labels activities with the selection 'obstructed' in the HotSpot spreadsheet.

Part indicators

These indicators label parts with high environmental impact (6) or economic value (7). Both labels follow flagged parts from the HotSpot Mapping spreadsheet.

3.3.3 RESULTS

The Disassembly Maps of all five assessed products can be found on the following pages. The ease-of disassembly of specific safety-critical parts and parts with crucial value-perception, as parts are commented in the following points. The first being required for the product to function properly, the latter being crucial for the product to be perceived as being functional and accepted by the user.

In general, all products follow similar approaches in their product assembly, pointing towards certain industry standards within this category. However, all products also showed many differences in their product architecture. The levels of assembly hierarchy ranges from seven in the Head Rachel model, to twelve in the Smith helmet model. (Fig. 57 to Fig. 61)

Parts with safety critical function

Both sides of the chin-strap can be removed after removing interior parts, obstructing access to the chin-strap baskets. After this, the chin-strap can be pulled out with the use of pliers, the stainless-steel pin removed and then pulled out of the helmet entirely. In both Atomic models and the Head Rachel model, 18 or 19 steps are needed to perform this task, the Smith model, as it has more layers of interior parts, needs 28 steps to perform this. (Tab. 2) The POC model provides a shortcut, yet the chin-strap has to be cut to be removed.

The chin-strap buckle is accessible in two or four steps after the chin-strap was removed, depending on the side.

The fitting-systems differ largely between the models. In both Atomic models, the mechanical part of the fitting-systems can be removed in a sound subassembly, after eleven steps were taken out. After the soft-liner was removed, two snap-joints and a formfit lock the fitting-system in place. In the models with Boa-systems (Head and Smith model), the fitting system is far more integrated. In the Head helmet model, the removal of the

fitting-system demands a destructive opening of the fitting-system pin and the cutting of the Boa-cable. In the Smith-model, the system can be removed fully, yet access is largely obstructed and many parts need to be removed in prior. The POC model follows a non-destructive approach, yet access to the closing screws is obstructed and parts can only be removed individually.

The solutions for oblique impact protection are differently solved in the different products. In the POC model, the SPIN system can be removed in one step, as it is integrated in the main padding. In the Atomic models, the AMID foam-pads can be removed in 16 steps and in the Smith Vantage MIPS helmet, the system needs five steps to be removed. In both these models, the soft-liner has to be removed, and then either the parts are hold by adhesive surfaces (AMID) or form-fitted rubber-holders (MIPS).

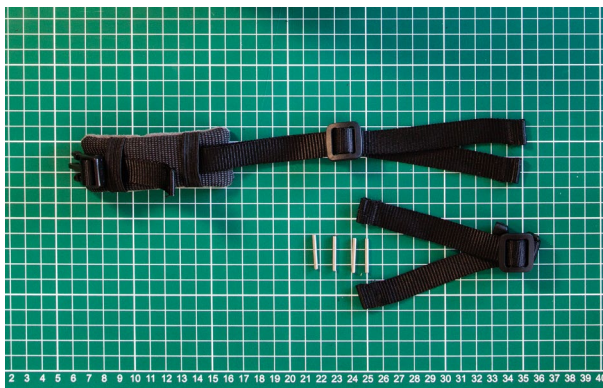

Fig. 49 – Chinstrap parts after removal

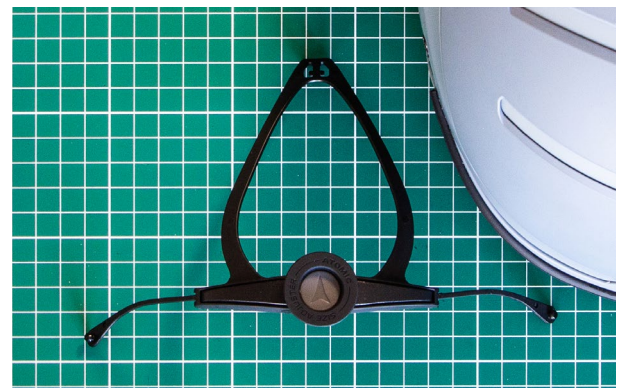

Fig. 51 – Fully intact mechanical parts of fitting-system



Fig. 50 – Removing the POC fitting-system



Fig. 52 – Removing the MIPS-system

ASSESSMENT OF CURRENT SKI-HELMETS

As main safety-crucial part, the EPS liner and the shell are found almost at the end of the assembly in all assessed products. As was the common outcome, these parts are found within in-mold assemblies, with other parts, like the bottom-ring, chin-strap fixations and other fixation elements. These subassemblies can not further be taken apart and contain up to twelve different parts (and even more individual parts). This includes many parts with safety-crucial priority or parts with crucial value-perception, but also parts with high economic value and environmental impact.

Parts with crucial value-perception

Soft liners and inside paddings are, next to shell parts, important elements for the user's perception of the products quality and intactness. For these elements, different approaches are in place, from a fully integrated soft liner and earpad system in the Atomic helmets, to separated systems of soft-liner and earpad and ear- and neck-systems.

The Atomic models' soft liners are removable in ten steps, after pulling the two sides of the chinstrap through textile holders on the earpads and releasing the earpads' friction-fits.



Fig. 53 — Remaining in-mold assembly parts



Fig. 55 — Textiles and soft-paddings in the POC model

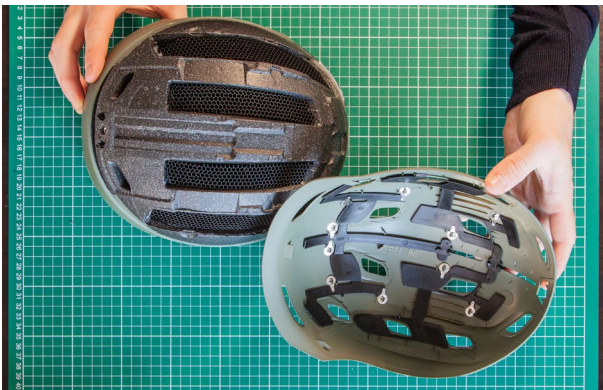

Fig. 54 — In-mold assembly and top-shell parts

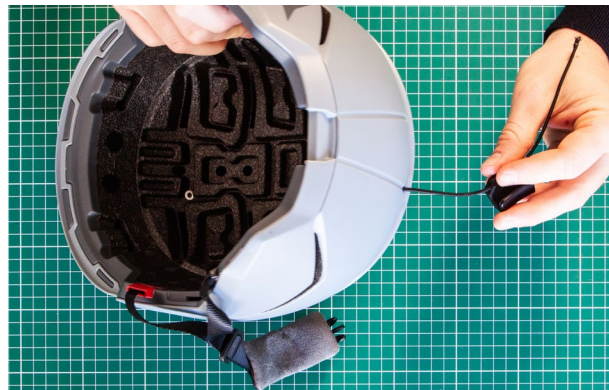

Fig. 56 — In-mold assembly and top-shell parts

In some models, (parts of) the shell can be removed from the compound. In the Atomic Savor GT AMID Visor model, the top-shell is removable in two steps, after removing a screw, hidden behind a decorative sticker. In the Smith model this follows a similar approach — 19 steps are needed to open the goggle-retainer, remove the sticker, the screw and the stainless holders of the ventilation-sliders. In the Atomic Savor AMID helmet, the shell is glued onto the in-mold assembly and is removable in 14 steps. However, this process is timely and can damage the in-mold assembly.

In the other models, the soft liners can be removed within one (Poc & Smith) or two steps (Head), however the earpads require further actions: From five steps in the Head model to thirteen in the Smith model. The earpads in the Head and Poc models can be removed after pulling the chinstrap through textile straps on the earpads, and then removing two friction fits. In the Smith model, the Boa-system, particularly the cable has to be removed first, and then the ear- and neck-padding can be removed, leading to 14 needed actions.

The POC model also has a neck-padding section, which is fixated to the fitting system by two screws, needing eight additional steps, totalling at 18 actions to remove all soft paddings from the helmet's inside — the largest number, comparing to the other models.

In visor-helmets, removing the lens also takes a different amount of steps and sequences. In the Head-model, the visor is held by two snapjoints. In the Atomic model, two screws have to be unscrewed and then both sides holding parts removed. Considering the low number of steps, the Head-model involved a larger amount of difficulty, compared to the Atomic model.

Other parts, that can degrade in their perceived value are contact parts, involved in user-interaction, like toggles of fitting-systems and slider-grabs in ventilation systems or goggle retainers. In goggle retainers, there are different approaches in place. The POC Fornix SPIN model allows full removal of the goggle-retainer after

unhooking the retainer-rubber and removing three screws with an Allen-key. In the Atomic models, the inside soft-liner has to be removed to access the inside fixation. The full removal involves ten steps and includes cutting off the holding knot of the retainer rubber, if it cannot be untied. In the Smith model, the top-shell has to be removed to access the rubber-fixation. Six steps are necessary to remove the part.

Removing the fitting-system toggle ranges from twelve steps in the Atomic helmets to two steps in the Boa-models. In the latter case, the Boa-pin can only be removed in a destructive way.

Ventilation slider-grabs are removable in five steps in the Atomic Savor GT AMID Visor and the Smith model, after removing the top-shell. In the Head-model, this is facilitated within one step, however the removal of the snap-fit deforms the holding part. In the POC model, a EPS-part has to be removed in two steps from the inside before removing the ventilation slider, this is a fully destructive process.

Tab. 2 – Number of tasks to remove different parts

A selection of priority parts and what it takes to remove them.

Chinstrap	18	19	18	28	13
In-Mold Assembly	48	38	39	65	33
Top-Shell	2	-	14	19	-
Fitting System	11	5	11	13	11
Oblique impact system	16	-	16	5	1
Soft-paddings & textiles	10	7	10	14	18
Soft liner	10	2	10	1	1
Neckpad	-	-	-	-	8
Earpads	-	5	-	13	9
Visor	4	2	-	-	-
Goggle retainer	10	-	10	6	4
Ventilation sliders	5	1	12	5	2



Brand	Atomic	Head	Atomic	Smith	POC
Model	Savor GT AMID Visor	Rachel	Savor AMID	Vantage MIPS	Fornix SPIN

ASSESSMENT OF CURRENT SKI-HELMETS

Disassembly Map Atomic Savor GT AMID Visor



Parts

- 1 part
- 2 safety critical / hygiene priority Part
- A subassembly
- B resulting subassembly with included parts
- 3

Activities

- (H) hands
- (Sc) screwdriver
- (S) spudger
- (P) pliers
- (K) knife

Indicators

- ⌚ time intensive
- 🔧 force intensive
- 🔍 high precision
- ⊗ un reusable fastener
- ♻️ environmental impact
- € economic value

Abbreviations

- PB Push Button
- SF Snap-Fit
- FF Friction-Fit
- VC Velcro

Part List

- A Liner Assembly
 - 1 EPS
 - 2 Snap Basket
 - 3 PC Basket
 - 4 Middle Shell
 - 5 Lower Shell
 - 6 Lower Ring
 - 7 Screw Basket
 - 8 Insert Basket snap
 - 9 Side insert part
 - 10 Earpad insert female
 - 11 Strap Baskets
 - 12 FS Fixation Part
- 13 Chinstrap Pins
- 14 Top Shell
- 15 Ventilation System
- 16 Star Sticker
- 17 Star Sticker Screw
- B Fitting System
 - 18 FS Screw
 - 19 FS Knob
 - 20 FS Pin
 - 21 FS Gear
 - 22 FS Arms
 - 23 FS Top Cover
 - 24 FS Holder
- C Fitting Headband
 - 25 Live-Fit Snaps
 - 26 Live-Fit Velcro
 - 27 Live-Fit Foam
 - 28 Live-Fit Carrier
- 29 Goggle Retainer Cord
- 30 Goggle Washers
- 31 Goggle Hook
- 32 Velcro pads
- D1 Chinstrap Right
 - 33 Side Divider
 - 34 Chin Fabric
 - 35 Buckle
 - 36 Rubber Ring
 - 37 Chinstrap Webbing
- 38 AMID Foampads
- 39 Visor Screw
- 40 Visor Side Plastic Part
- 41 Visor
- 42 Visor face foam
- 43 Visor bottom frame
- 44 Visor Top Seal
- 45 Visor Alu Logo
- E Soft Liner Assembly
 - 46 Soft Liner
 - 47 Earpad hooks male

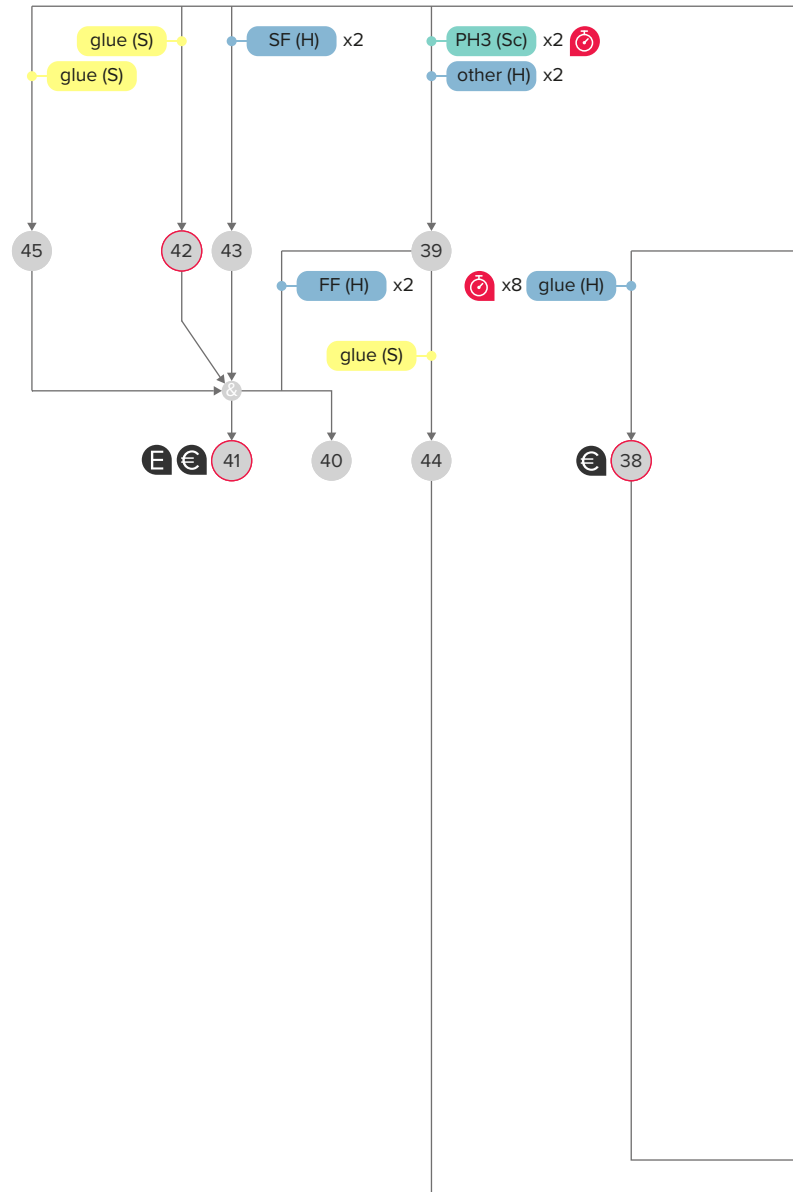

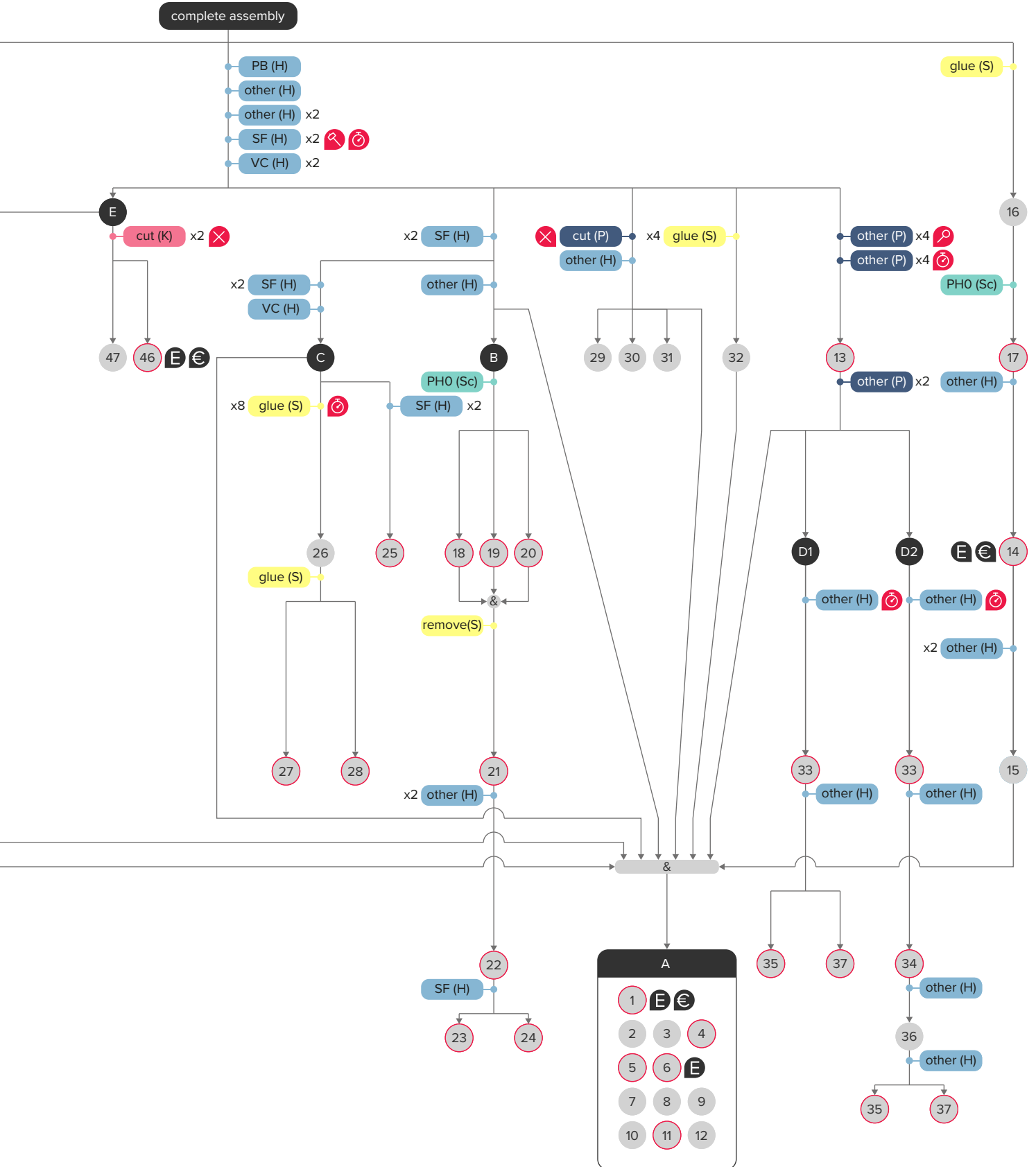

Fig. 57 – Disassembly Map Atomic Savor GT AMD Visor

ASSESSMENT OF CURRENT SKI-HELMETS

Disassembly Map Head Rachel



Parts

- 1 part
- 2 safety critical / hygiene priority Part
- A subassembly
- B resulting subassembly with included parts
- 3

Activities

- (H) hands
- (Sc) screwdriver
- (S) spudger
- (P) pliers
- (SC) side-cutter pliers

Indicators

- time intensive
- force intensive
- high precision
- un reusable fastener
- obstructed access
- environmental impact
- economic value

Abbreviations

- PB Push Button
- SF Snap-Fit
- FrF Friction-Fit
- VC Velcro
- FoF Form-Fit

Part List

- A Liner Assembly
 - 1 EPS
 - 2 Lower Ring
 - 3 Topshell
 - 4 Decorative Elements (green)
 - 5 Vent Guide
 - 6 Vent guides male
 - 7 Strap Baskets
 - 8 Earpad Baskets
 - 9 Visor Holder Basket
 - 10 Fitting System Holding Surfaces
 - 11 Visor Elastomer Tunnel
- 12 Chinstrap Pins
- 13 Vent Slider
- 14 Vent Plates
- B Fitting System
 - 15 Fitting Cap Front
 - 16 Fitting Cap Back
 - 17 Fitting System Pins
 - 18 Velcro Strips
 - 19 Boa Tube
 - 20 Boa Tube Stickers
 - 21 Boa Pin
 - 22 Boa Toggle
 - 23 Boa Inside-Ring
 - 24 Boa Inside-Disk
 - 25 Boa Inside-Lever
 - 26 Boa wire
 - 27 Boa Base Velcro
- C Boa Base Assembly
 - 28 Boa Base Ring
 - 29 Boa Base
- D1 Chinstrap Right
- D2 Chinstrap Left
 - 30 Side Divider
 - 31 Chin Fabric
 - 32 Rubber Ring
 - 33 Buckle Fidlock
 - 34 Chinstrap Webbing
- 35 Earpads
- 36 Soft Liner
- E Visor Assembly
 - 37 Visor Hooks
 - 38 Visor
- F Visor Elastomer Assembly
 - 39 Visor Elastomer Ends
 - 40 Visor Elastomer

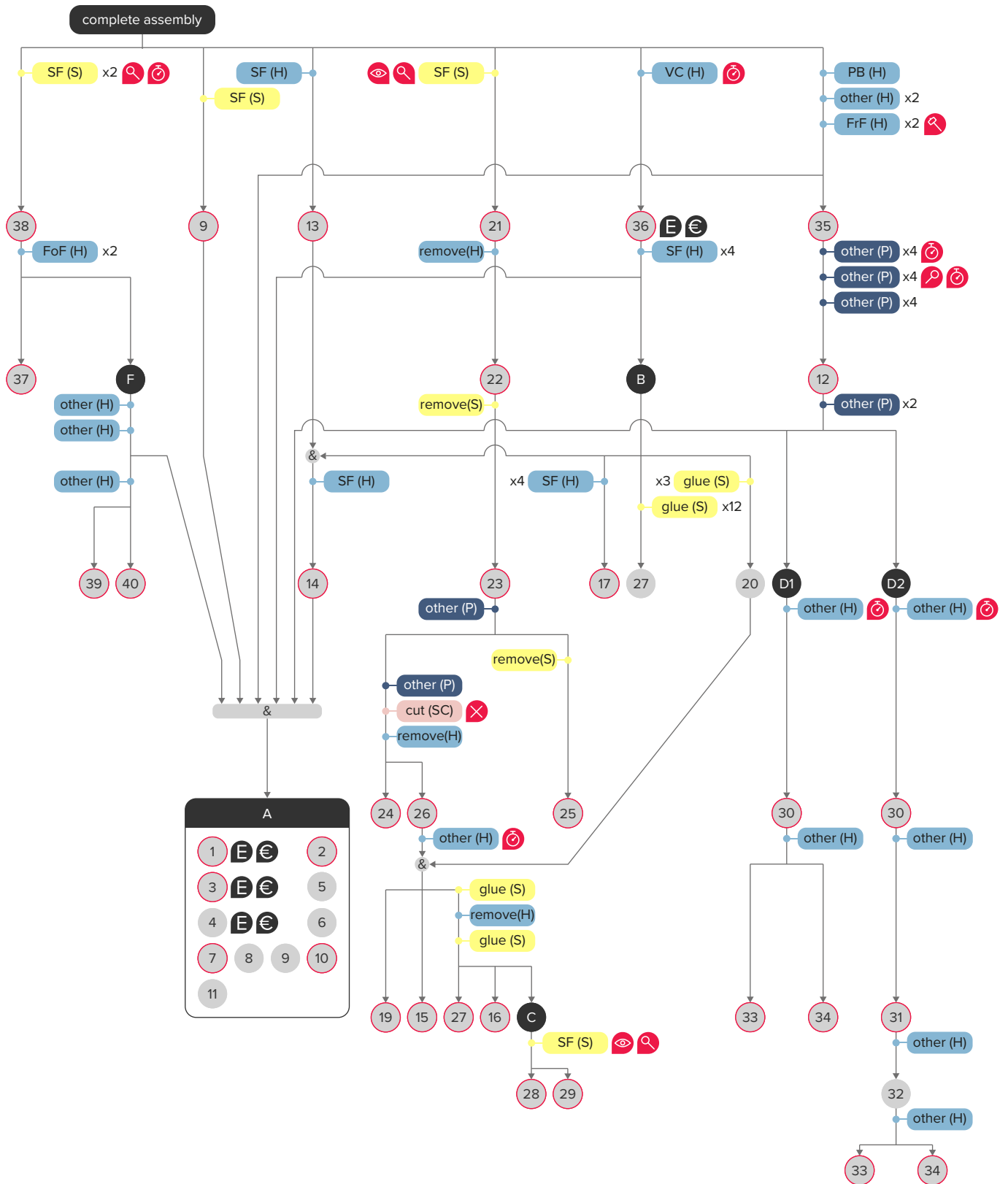

Fig. 58 — Disassembly Map Head Rachel

ASSESSMENT OF CURRENT SKI-HELMETS

Disassembly Map Atomic Savor AMID



Parts

- 1 part
- 2 safety critical / hygiene priority Part
- A subassembly
- B resulting subassembly with included parts
- 3

Activities

- (H) hands
- (Sc) screwdriver
- (S) spudger
- (P) pliers
- (K) knife

Indicators

- time intensive
- force intensive
- high precision
- un reusable fastener
- environmental impact
- economic value

Abbreviations

- PB Push Button
- SF Snap-Fit
- FF Friction-Fit
- VC Velcro

Part List

- A Liner Assembly
 - 1 EPS
 - 2 Lower Ring
 - 3 Snap Basket
 - 4 Earpad insert female
 - 5 Adjuster Inside Holder
 - 6 Strap Baskets
 - 7 Shell Guiding Inserts
 - 8 Chinstrap Pins
- B Topshell Assembly
 - 9 Top Shell
 - 10 Ventilation Holders
 - 11 Ventilation Sliderplate
- C Fitting System
 - 12 FS Screw
 - 13 FS Knob
 - 14 FS Logo Plate
 - 15 FS Gear
 - 16 FS Arms
 - 17 FS Top Cover
 - 18 FS Holder
- D Fitting Headband
 - 19 Live-Fit Snaps
 - 20 Live-Fit Velcro
 - 21 Live-Fit Foam
 - 22 Live-Fit Carrier
- 23 Goggle Retainer Cord
- 24 Goggle Washers
- 25 Goggle Hook
- 26 Velcro pads
- E1 Chinstrap Right
- E2 Chinstrap Left
 - 27 Side Divider
 - 28 Chin Fabric
 - 29 Rubber Ring
 - 30 Buckle
 - 31 Chinstrap Webbing
- 32 AMID Foampads
- F Soft Liner Assembly
 - 33 Soft Liner
 - 34 Earpad hooks male

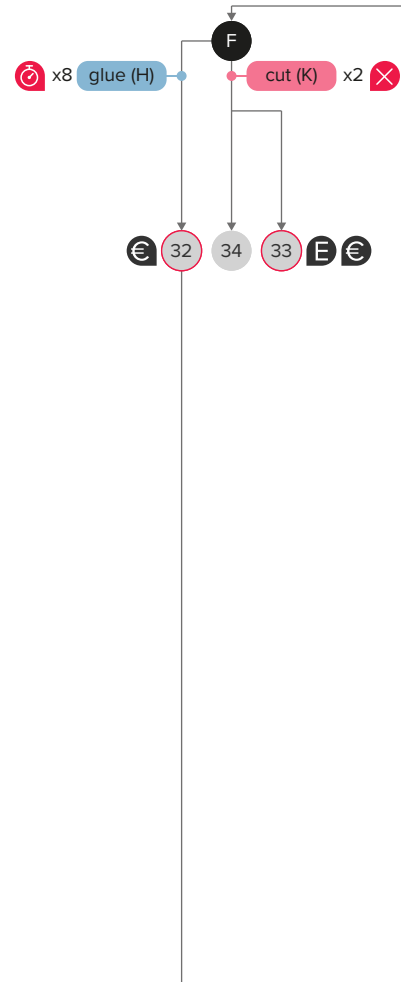

DISASSEMBLY MAPS

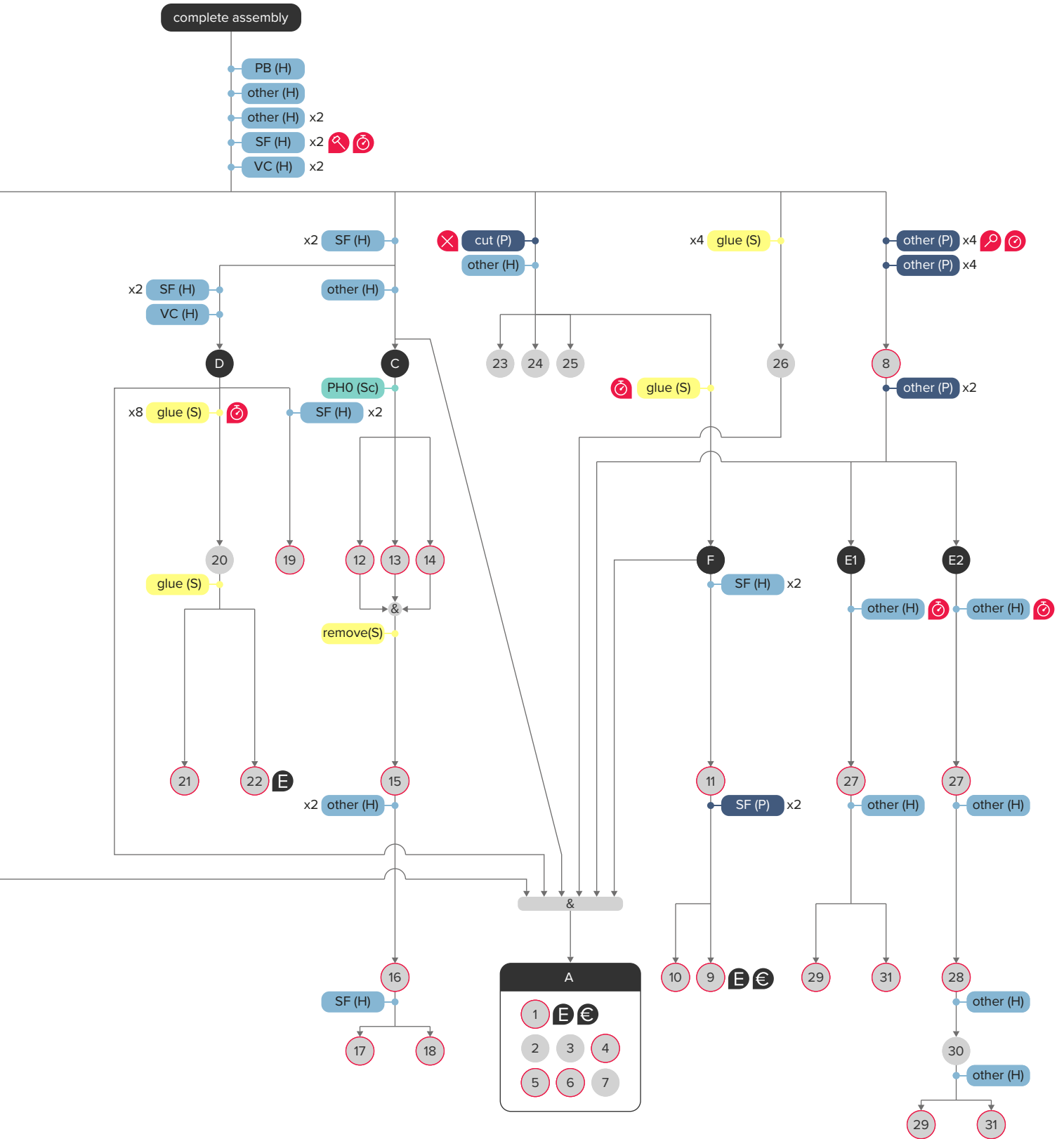

Fig. 59 – Disassembly Map Atomic Savor AMID

ASSESSMENT OF CURRENT SKI-HELMETS

Disassembly Map Smith Vantage MIPS



Parts

- 1 part
- 2 safety critical / hygiene priority Part
- A subassembly
- B resulting subassembly with included parts

Activities

- (H) hands
- (Sc) screwdriver
- (S) spudger
- (P) pliers
- (SC) side-cutter pliers

Indicators

- ⌚ time intensive
- 🔍 force intensive
- 🎯 high precision
- ⊗ un reusable fastener
- 👁️ obstructed access
- ♻️ environmental impact
- € economic value

Abbreviations

- PB Push Button
- SF Snap-Fit
- FrF Friction-Fit
- VC Velcro
- FoF Form-Fit

Part List

- A Liner Assembly
 - 1 EPS
 - 2 Lower Ring
 - 3 Lower Shell
 - 4 Topshell Screw Basket
 - 5 Koroyd Outside
 - 6 Koroyd Inside
 - 7 Snap Basket Front
 - 8 Snap Basket Back
 - 9 Snap Basket Side
 - 10 MIPS Baskets
 - 11 Strap Baskets
 - 12 Earpad Insert Female
- B Topshell Assembly
 - 14 Top Shell
 - 15 Ventilation Holders
 - 16 Foam Spacers
 - 17 Ventilation Slider
 - 18 Ventilation Sliderplate
 - 19 Screw Cover
 - 20 Topshell Screw
- C Goggle Retainer Handle
 - 21 Retainer Cord
 - 22 Retainer Grab
 - 23 Goggle retainer holder
 - 24 Goggle Hook Screw
 - 25 Goggle Hook
 - 26 Fitting System Front
 - 27 Fitting System Side
 - 28 Fitting System Covers
 - 29 Boa Pin
 - 30 Boa Toggle
 - 31 Boa Inside-Ring
 - 32 Boa Inside-Disk
 - 33 Boa Inside-Lever
 - 34 Boa wire
- D Boa Base Assembly
 - 35 Boa Base Velcro
 - 36 Boa Base Ring
 - 37 Boa Base
- E1 Chinstrap Right
 - 38 Side Divider
 - 39 Chin Fabric
 - 40 Rubber Ring
 - 41 Buckle
 - 42 Chinstrap Webbing
- E2 Chinstrap Left
 - 38 Side Divider
 - 39 Chin Fabric
 - 40 Rubber Ring
 - 41 Buckle
 - 42 Chinstrap Webbing
- F MIPS System
 - 43 MIPS Dome
 - 44 MIPS Edge Protectors
 - 45 MIPS Velcro
 - 46 MIPS Rubber Holders
 - 47 MIPS Base Elements
 - 48 Liner Velcros
 - 49 Ear and Neck Padding
 - 50 Earpad Foam
 - 51 Soft Liner
 - 52 Logoplate

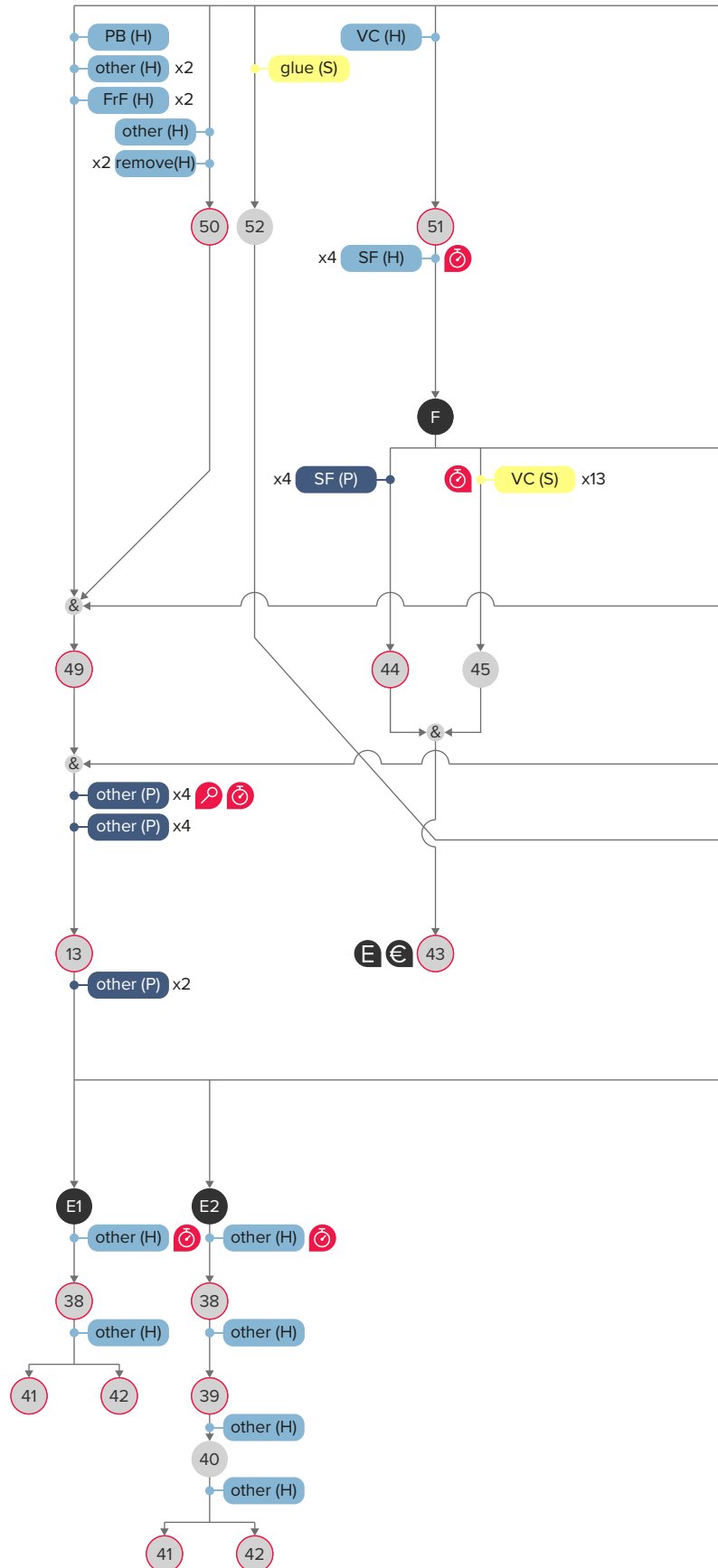

DISASSEMBLY MAPS

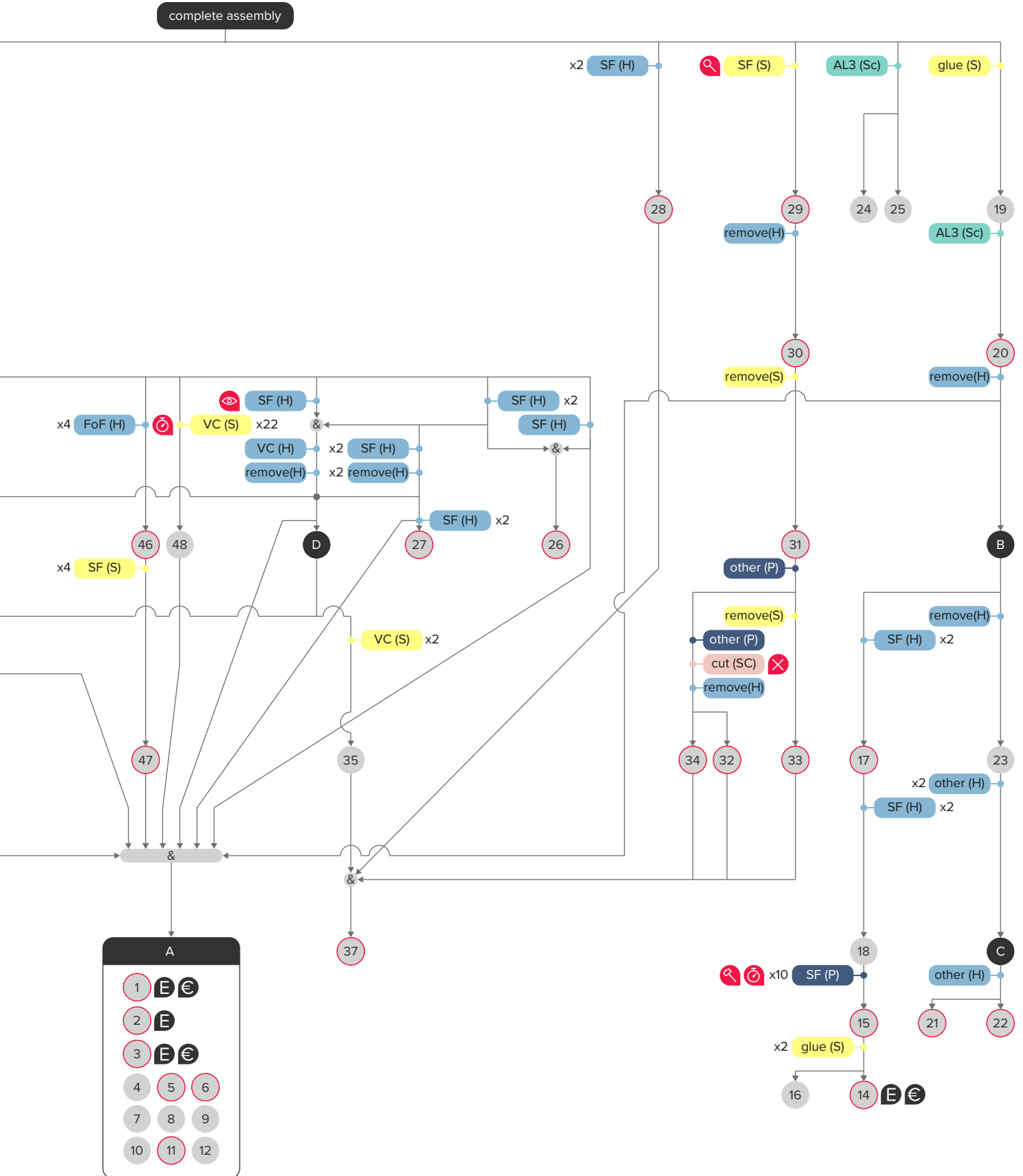

Fig. 60 – Disassembly Map Smith Vantage MIPS

ASSESSMENT OF CURRENT SKI-HELMETS

Disassembly Map POC Fornix SPIN



Parts

- 1 part
- 2 safety critical / hygiene priority Part
- A subassembly
- B resulting subassembly with included parts
- 3

Activities

- (H) hands
- (Sc) screwdriver
- (S) spudger
- (Sci) scissors
- (K) knife

Indicators

- ⌚ time intensive
- 🔍 force intensive
- 🔎 high precision
- ✂️ un reusable fastener
- 👁️ obstructed access
- ♻️ environmental impact
- € economic value

Abbreviations

- PB Push Button
- SF Snap-Fit
- FrF Friction-Fit
- VC Velcro
- FoF Form-Fit

Part List

- A Liner Assembly
 - 1 EPS
 - 2 Top Shell Outside
 - 3 Top Shell Aramid
 - 4 Lower Ring
 - 5 Strap Baskets Male
 - 6 Strap Baskets Female
 - 7 Strap Basket
 - Closing Element
 - 8 Earpad Baskets
 - 9 Goggle Retainer
 - System Positioning Part
 - 10 Goggle Retainer
 - System Screw Baskets
 - 11 Rear Snap Basket
 - 12 Front Snap Baskets
 - 13 Ventilation Liner
 - 14 Ventilation Disk
- B Fitting System
 - 15 Fitting System Holder
 - 16 Fitting System Spring
 - 17 Fitting System Toggle
 - 18 Fitting Ring Velcro
 - 19 Fitting System Pin
 - 20 Fitting System Screws
 - 21 Fitting System Ring
 - 22 Fitting System Lock
- C Fitting System Base
 - 23 Fitting System Cover
 - 24 Fitting System Plate
- D1 Chinstrap Right
 - 25 Side Divider
 - 26 Chin Fabric
 - 27 Rubber Ring
 - 28 Buckle
 - 29 Chinstrap Webbing
- D2 Chinstrap Left
 - 25 Side Divider
 - 26 Chin Fabric
 - 27 Rubber Ring
 - 28 Buckle
 - 29 Chinstrap Webbing
- 30 Earpads
- 31 Main Padding
- 32 Liner Velcro
- 33 Vent Stoppers
- 34 Neck Padding
- 35 Retainer Screws
- 36 Retainer Rubber
- 37 Retainer Hook

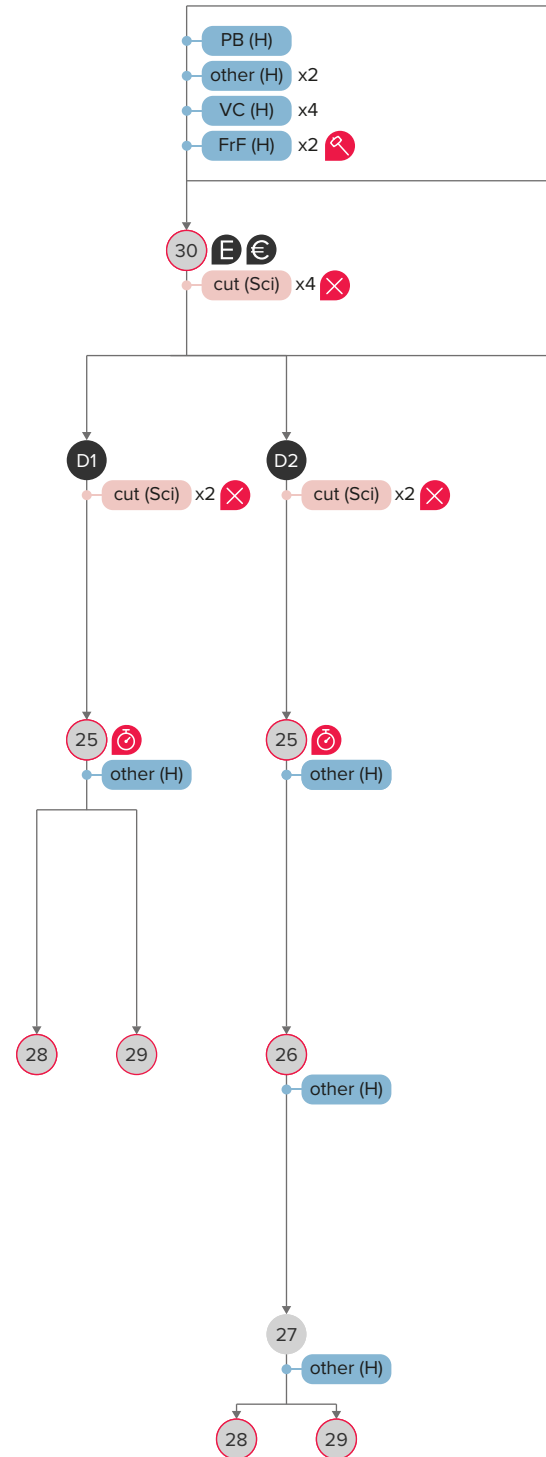

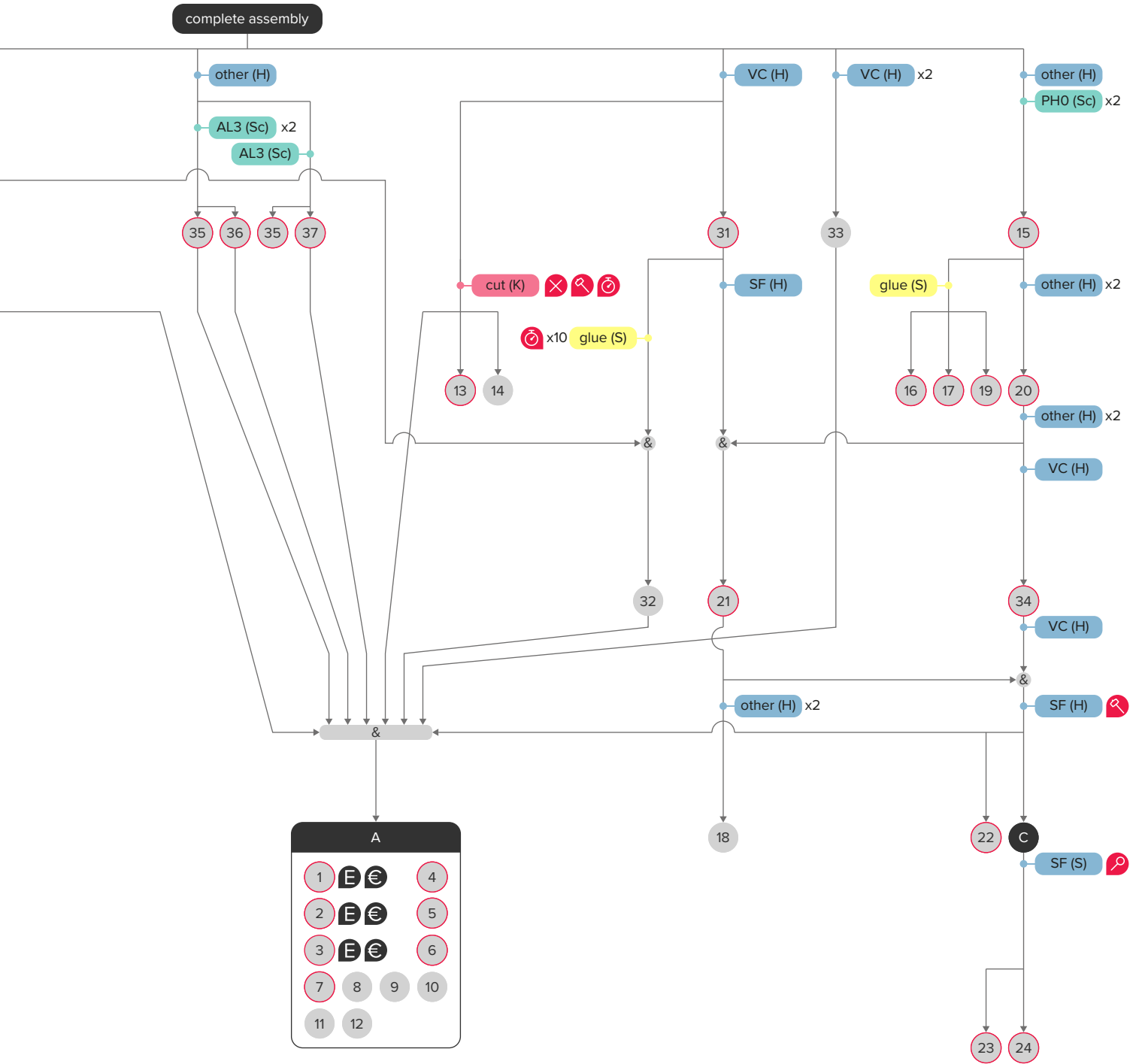

Fig. 61 – POC Fornix SPIN

3.5 ECOLOGICAL IMPACT & ECONOMIC VALUE

3.5.1 CURRENT IMPACT

The products in focus were also analysed using the Lifecycle Assessment-method (LCA). The materials and part-weights in the Atomic products were taken from detailed bills of materials. For the other products, assumptions on material-specification were made, based on similar parts in the Atomic models. For the assessment, the software Granta Edu Pack was used. To also gain information about the proportionate impact in different lifecycle phases, information about manufacturing, transport and end-of-life scenarios were added:

- For manufacturing, the last production stage was selected in the assessment system, e.g. thermoforming, mold-injection, etc.
- For transport, the seafare-transport from the factory in China (containership), the transport from Rotterdam to the middle-European storage-facility (long haul truck) and the transport to the client (short distance) was estimated at roughly.
- For end-of-life, metals were assumed to be downcycled, all other materials to be incinerated.

Other than the material-stage, where detailed data was available, the data on manufacturing, transport and end-of-life is subject to large uncertainties, as no detailed information is available on these. Yet, for a comparison of impact-proportion in different lifecycle-stages, this data is valid.

Looking at Fig. 62, the majority of the impact on carbon footprint- (73%) and embedded energy-level (84%) is located in the material lifecycle-stage.

Furthermore, the end-of-life scenarios of downcycling or incinerating of certain parts allows an energy-regain of 7%, but also leads to an increase of 32% in the emitted CO₂.

ECOLOGICAL IMPACT & ECONOMIC VALUE

Fig. 62 – Environmental impact and embodied Energy
Average values of the products analysed to illustrate the proportion of their impact. Most impact is found in the material lifecycle-stage.

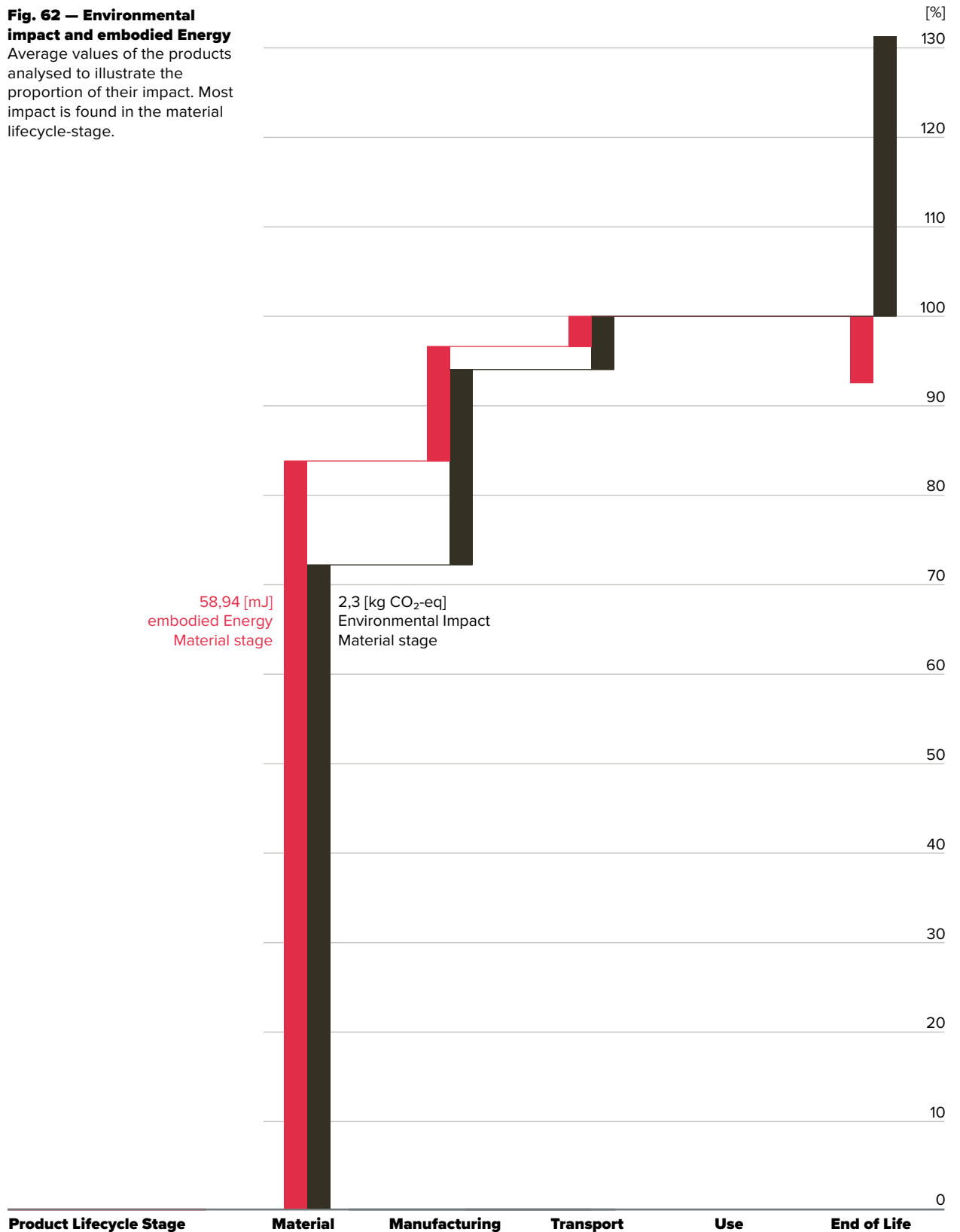

ASSESSMENT OF CURRENT SKI-HELMETS

Carbon footprint on material level

The differences in carbon-footprint between the different products is mainly caused by products using visors and products without, but also in different sizes of products, available for the comparison. (Fig. 63) Most CO₂-impact is found in the Atomic Savor GT AMID Visor model (2,7 kg CO₂-eq), the least is found in the Atomic Savor AMID model (2,05 kg CO₂-eq)

3.5.2 MATERIALS IN USE

Considering the different materials used in the assessed products, there are certain similarities. (Fig. 64) In the Atomic Savor GT AMID Visor, 15 different materials are used. In the other Atomic model, but also the Head and the POC models, 14 different materials are used. Commonly used materials are collected in Tab. 3, the example follows the materials used in the Atomic Savor GT AMID Visor.

Material	Weight [g]	Proportion of Weight [%]
PC	161,5	24,2%
EPS	160	24,0%
ABS	84	12,6%
PA66 (Nylon)	79,3	11,9%
Dacron (Polyester fibers)	78,4	11,7%
EVA (Ethylenvinylacetat)	29,4	4,4%
TPU (Thermoplastic PU)	20,0	3,0%
Polyethylene Foam	20,0	3,0%
Merino	11,0	1,6%
POM (Polyoxymethylene)	9,0	1,3%
Aluminium	6,3	0,9%
Stainless Steel	5,9	0,9%
Brass	1,8	0,3%
Steel	0,5	0,1%
Latex	0,4	0,1%

Tab. 3 – Materials Savor GT AMID Visor

As also indicated by Fig. 64, 19 different materials are used in the Smith Vantage MIPS model. These materials are elastomer foam, PVC, a rubber material for the MIPS fasteners and nylon (PA11) for the Boa-wire.

3.5.3 INSEPARABLE COMPONENTS

As visualised in the Disassembly Maps, many parts are located in the inseparable in-mold assembly, holding everything from the EPS-liner, shell parts to different in-molded fixations. These in-mold assemblies are accountable for a large portion of the total weight of the helmet. Fig. 65 shows, that especially in helmets with full in-mold construction, like the Head and POC models, the assembly is accountable for over 50% of the full weight. In helmets with removable top-shell, like the Atomic Savor GT AMID Visor or Smith Vantage MIPS models, this accounts for 38% or 36%, respectively. Only the helmet with hardshell-technology has a rather low proportion of 28% — if the shell is removed.

Within these in-mold assemblies, different materials are inseparably joined. From five different materials in the Atomic Savor GT AMID Visor, the Smith and the POC models, to three materials in the other Atomic- and the Head-model. (Fig. 66) Materials typically included are EPS, PC, PA66, Stainless Steel, Aluminium or Brass.

ECOLOGICAL IMPACT & ECONOMIC VALUE

Fig. 63 – Carbon-footprint on material level
Showing the carbon-equivalent of the used materials in the different products

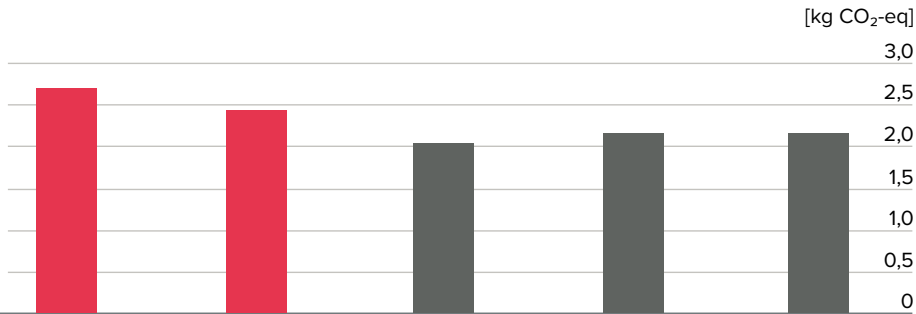

Fig. 64 – Number of different materials used
Many different materials are used in ski-helmets

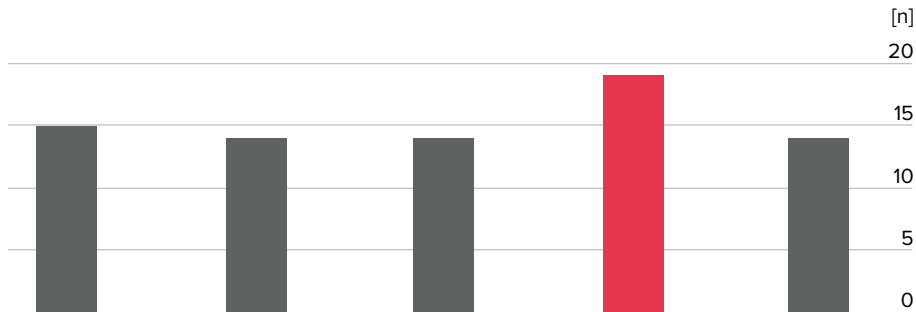

Fig. 65 – Weight proportion of unseparable in-mold liner
The unseparable in-mold assembly holds a specific amount of weight, this is connected to the build of the helmet

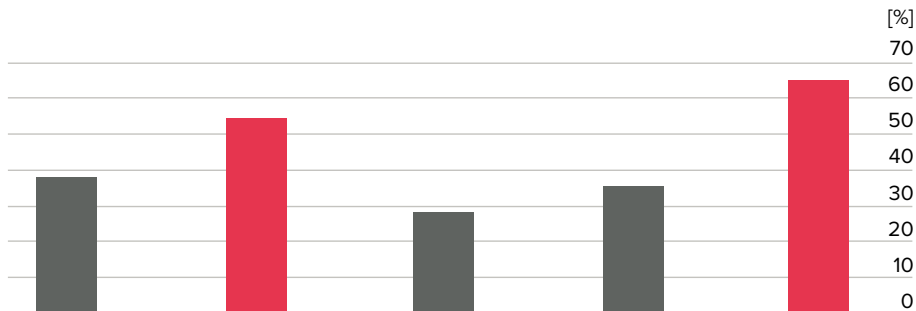
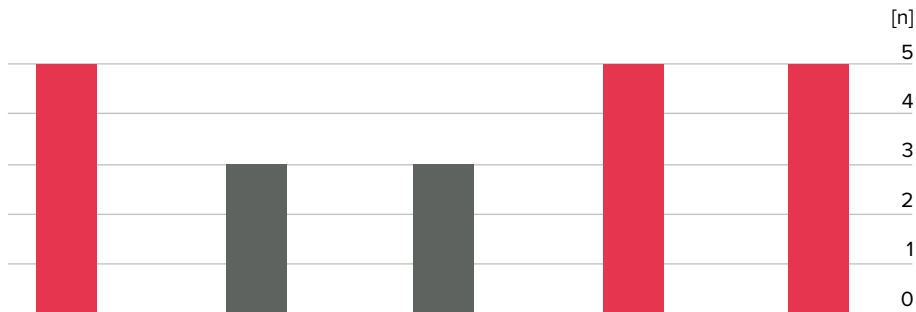

Fig. 66 – Number of materials in in-mold liner
The in-mold liner also holds up to five different materials



Brand	Atomic	Head	Atomic	Smith	POC
Model	Savor GT	AMID Visor	Rachel	Vantage MIPS	Fornix SPIN

3.5.4 IMPACT OF MATERIALS AND COMPOUNDS

As previously specified, the in-molded assemblies at the core of the majority of ski-helmets has a significant portion of the products total weight. Fig. 67 indicates their connection to large portions of the helmet's embodied energy, the CO₂-footprint and the economic value of the materials used.

Looking at the bottom of the graphic, the embodied energy and the economic value make a smaller portion of the overall impact, in relation the weight of the in-mold assembly. The CO₂-footprint is even smaller in proportion, but still accounts for ca. 30% of the product's total impact.

Another inseparable part, the padding parts (including the soft-liner and chinstrap-padding) have a much larger CO₂-footprint proportion, than their weight-proportion would suggest. In closer detail, the Dacron-material (Polyester), used for textile webbing, has only half the proportion in the economic value. Opposite to that stands the Polyethylene foams, with large economic value. Furthermore, merino-wool, has a tremendous increased CO₂-footprint in relation to the used weight.

A value that is not included in the graphic is the water usage. Wool makes almost 90% of the total water used for the product's materials, with 170.000 liters per kilogram material, not considering the manufacturing.

Other parts with a proportionately larger impact and value are functional nylon parts (PA66) with high values in energy, impact and value. This is also true for parts made from Aluminium, with significantly larger portions in the embodied energy and their carbon-footprint.

Fig. 67 – Environmental impact and embodied Energy
Average values of the products analysed to illustrate the proportion of their impact. Most impact is found in the material lifecycle-stage.

Aluminium Parts made from this metal have increased embodied energy and carbon-footprint.

Nylon parts (PA66) These parts have significantly higher impact, embodied energy and value, compared to their weight.

Soft paddings and textiles These inseparable elements have large CO₂-impact, compared to their total weight.

In-mold assembly
The structural core of the product has the largest proportions in impacts and value, even as their proportions are lower than the total weight.

ECOLOGICAL IMPACT & ECONOMIC VALUE

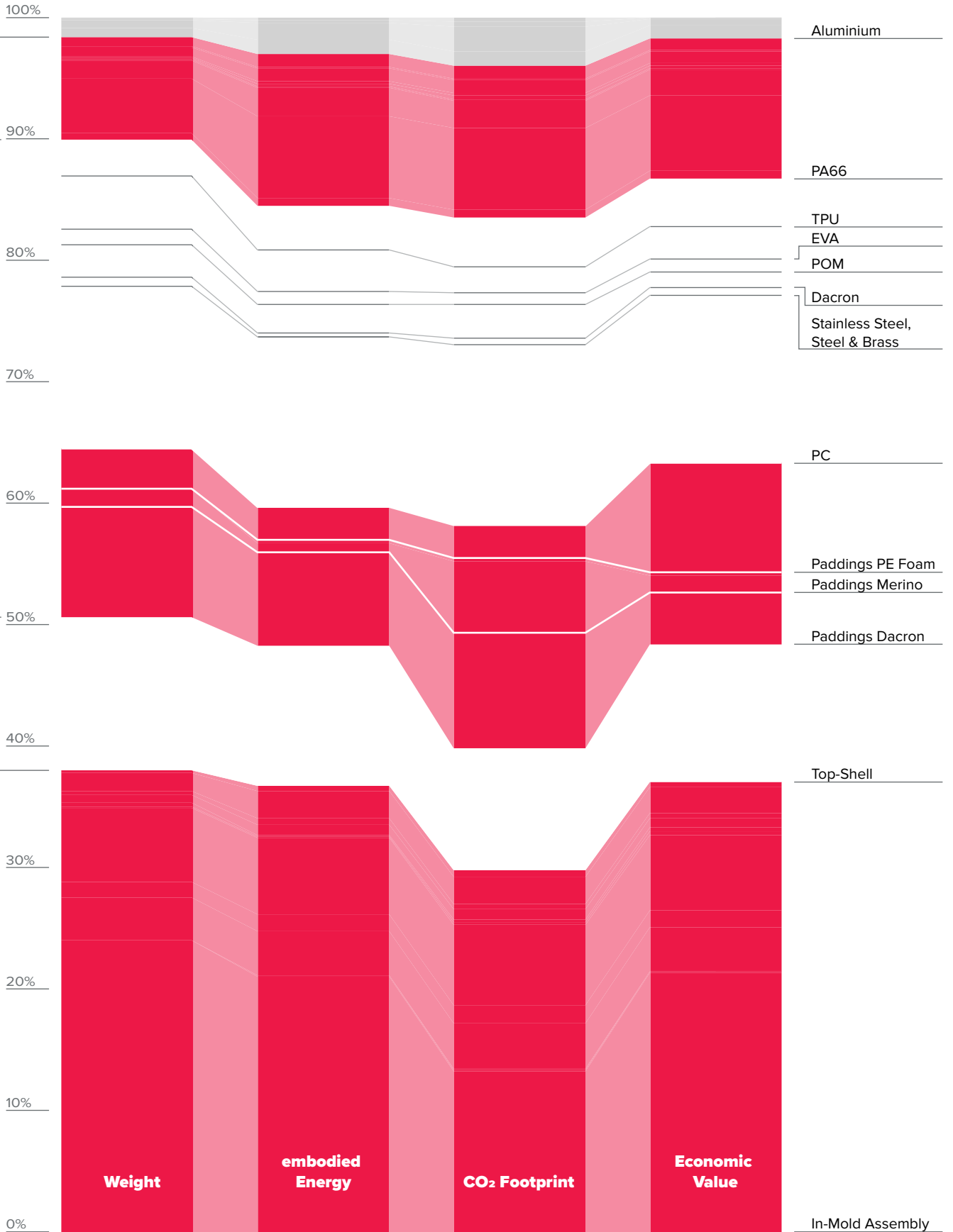

3.5.5 IMPACT OF PRIORITY PARTS

Large priority parts also have large influence on the product's total carbon-footprint, the embodied energy and embedded economic value. Fig. 68 shows these elements:

- EPS-Liner – as previously stated, the EPS-liner, as biggest part of the in-mold assembly also bears the largest portion of embodied energy and economic value, and a large part of the carbon-footprint of the product.
- The shell-parts, precisely the in-molded PC shells and lower-rings made from PC and the ABS top-shell collectively hold between 22% and 23% of the respective impacts and values.
- The soft-liner, as a priority part with crucial perceived value, was described in detail in chapter 3.5.4

Furthermore, as parts with only partial priority, or as parts that are not included in all products:

- The ventilation sliderplates, as large PA66 parts also follow the description in the previously stated chapter
- In visor models, the visor, being a large part of thermoformed Polycarbonate (PC), the proportions of impact and value follow the large weight

In conclusion, seven individual parts with large priority and a total weight proportion of 61% of the total product account for 55% of the total embodied energy; 53% of the CO₂-footprint and 58% of the total economic value.

Fig. 68 – Environmental impact and embodied Energy
Average values of the products analysed to illustrate the proportion of their impact. Most impact is found in the material lifecycle-stage.

Large plastic parts, like ventilation sliders or helmet visors

The PA66 ventilation slider has a larger proportion of impact, compared to its weight, PC parts are spread more evenly

The soft liner is single-part with the second-largest impact, after the EPS Liner

Shell parts All shell parts combined make the largest portion of the product's total impact.

EPS-Liner Even as the impact is considerably lower than the part's weight, it is still a large portion of the impact, only considering the material

ECOLOGICAL IMPACT & ECONOMIC VALUE

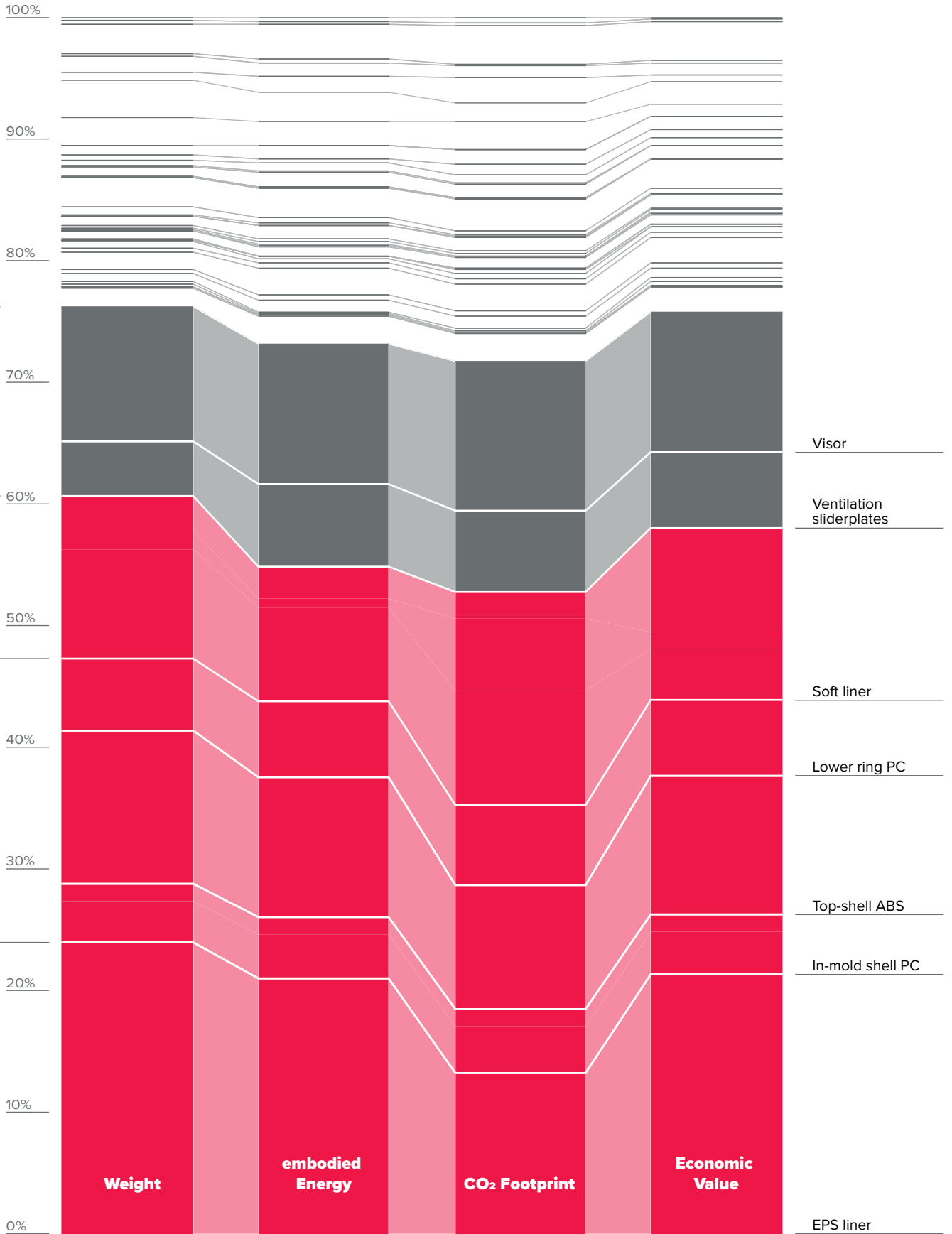

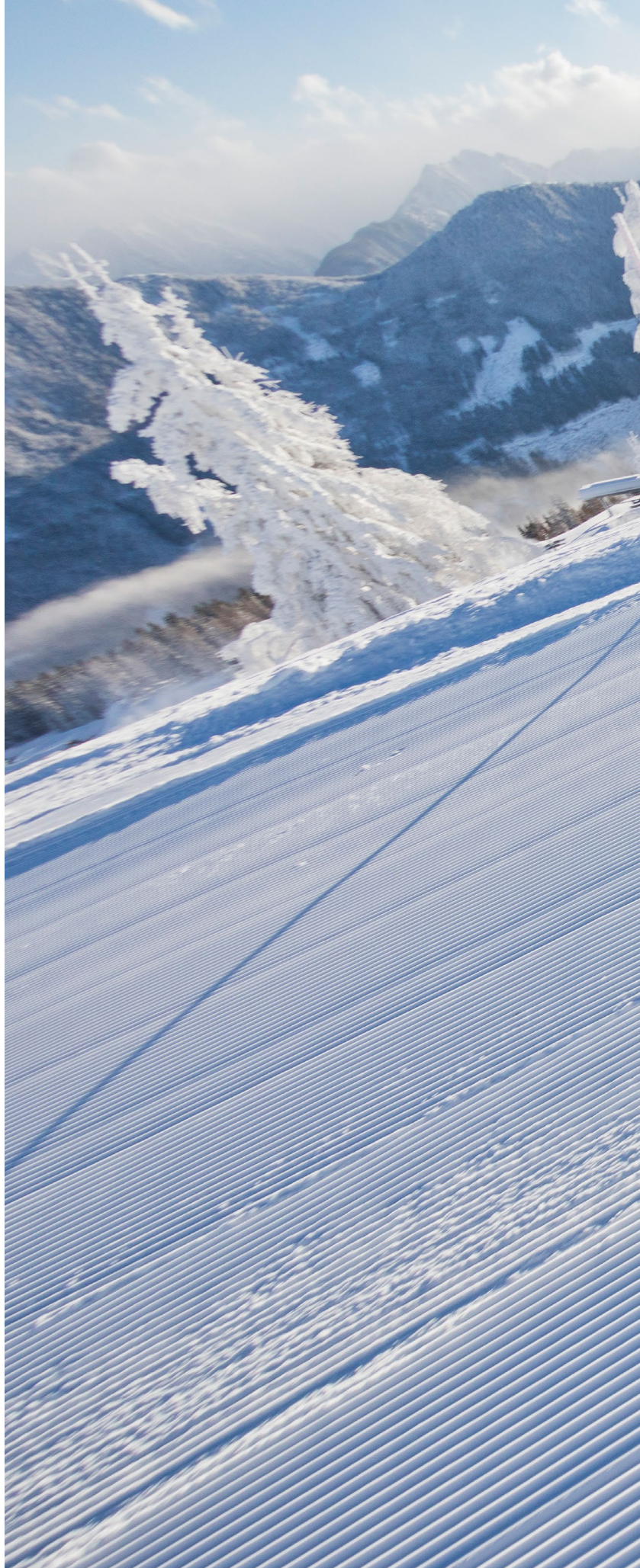



4 KEY FINDINGS

This chapter shows a collection of research findings, puts them into relation and answers the first sub research-questions.

1

Helmets are single-impact items. Most users adhere to this and replace them accordingly.

RQ1 What ensures the safety critical functionality of ski-helmets?

- RQ1.1 Which parts of ski-helmets are safety critical?
- RQ1.2 How can material health of safety critical parts be assessed, to inform about their intactness and prevent early-discarding?

EPS-foams and outer shells made from ABS or PC are an industry-standard and responsible for energy-management through spreading impact energy over a large surface area and then let impact energy be transformed by crumbling of the EPS cells. This deformation leads to helmets being unusable after a critical impact. Currently, there are no largely-used possibilities for impact assessment — if helmets are damaged is difficult to diagnose. Atomic is developing an IoT system consisting of impact-sensors and an app to assess impacts in real-time and indicate product-health to users. However, the battery life of 60 days, and the environmental impact of electronic components is a large downturn for using this in a product with focus on sustainability. Other sensors, passive ones, would be better suitable for this but an acceptable option regarding dimensions, weight, axis measured or pricepoint does not exist yet.

Replacement of helmets after critical impacts is recommended. 43% of survey participants stated that they replace their helmet after any critical impact.

Parts involved in the safety-intactness of the product are referred to as safety critical priority parts.

2

Helmets are discarded because of obsolescence — but also because soft-paddings, textiles and shells are worn.

RQ2 Why are ski helmets currently discarded?

- RQ2.1 What is the current time of use for ski-helmets?
- RQ2.2 What are the most often recurring failures?
- RQ2.3 Are there non-safety-critical parts, that are associated with the helmet's discarding?

Helmets are currently recommended to be discarded after critical impacts. Yet, they are also discarded because of other reasons — The survey indicated, that 43% of users stop using these products because they become obsolete, as new technologies become available. Furthermore, 40% replace their helmet, when they are just worn, but still usable and 36% because they don't find the aesthetics pleasing anymore. Helmets are used considerably long, at an average of 5,86 years, yet 55% of users use them for less than five years.

Parts like soft-paddings & textiles, chinstraps and the outer shells are the parts most prone to damages. They are either closest to the user, involved in handling or adjustment, or can develop an unpleasant exterior, due to scratches and dents, or become obsolete because newer styling targets current fashion-trends.

These parts, textiles, paddings & shells, but also visors and interaction elements are referred to as priority parts with crucial value-perception.

3

Priority parts are not easily accessible and subassemblies can not be removed in one piece.

RQ3.3 What is the current status regarding dis- & reassembly?

Ski-helmets offer a rather horizontally-structured assembly, with six to nine levels of hierarchy. Many parts can be accessed from the first layer of assembly. However, many priority parts can only be removed after removing other parts — mostly following a linear approach, including cross-dependencies with other parts. Subassemblies, like fitting-systems are not always removable in one piece. The Atomic helmets both allowed full removal of the fitting-system's mechanics yet, this was not possible in the models with a Boa system.

During the disassembly process, the helmet's orientation has to be continuously altered, with parts fixed to the inside and others accessible from the outside. This increases disassembly time and difficulty.

4

Screws, snap-fits, form-fits and friction-fits instead of destructive connections.

RQ3.3 What is the current status regarding dis- & reassembly?



Fig. 69 — Destructive snap-fits in the Head Rachel helmet

Most connectors in the assessed helmets were either snap-fits, form-fits, friction-fits or systems involving screws. As most of these were non-destructive and therefore re-appliable, images like Fig. 69 (a destroyed snap-fit with a thermoformed, in-molded holderpart) show, that also destructive systems are in existence. Certain elements needed to be cut to remove (POC chinstraps and Boa-system cables) and some snap-fits developed damages, when being removed.

As screws are applicable for re-appliable connections, anodized screws developed unpleasant scratches and in screws, that are too soft, the drive deteriorates over time, making reoccurring application difficult.

5

Industry standards, similarities and differences – difficult and inspiring approaches in current helmet product-architectures

RQ3.3 What is the current status regarding dis- & reassembly?

The assessed helmets showed many similarities, and also large differences. Similarities were found in chinstrap-fixations and to use in-molded snap-fits as common fixation part. Differences were found mostly in fitting-systems (Toothed tracks versus Boa-cables), visor-fixations, goggle retainers (elastic-bands versus rubber hook), ventilation sliders (flat slider-sheets, elaborate mold-injection parts or rotational slider discs) and their accessibility, and also the POC approach of demanding the chinstrap-webbing to be cut to be removed.

However, the industry-standard approach of fixing the chinstrap through stainless-steel pins in baskets through form-fit also is difficult. It demands time and precision to perform as the access angle on the helmet's inside is troublesome and obstructed by different neighbouring parts.

The approach of letting the top-shell (partially) be removed via an inconspicuous fastener, e.g. in the Atomic Savor GT AMID Visor- and the Smith-model, is interesting. It gives non-destructive access to critical parts without obvious indication.

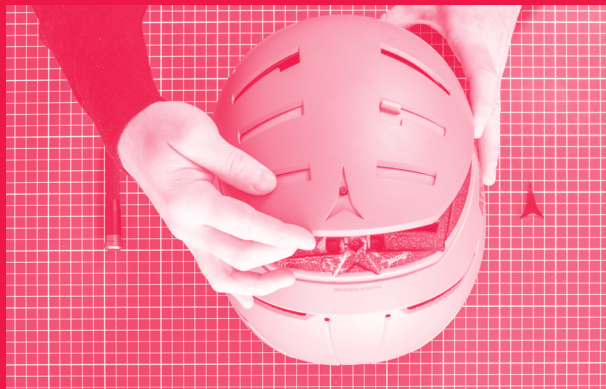

Fig. 71 – Destructive snap-fits in the Head Rachel helmet

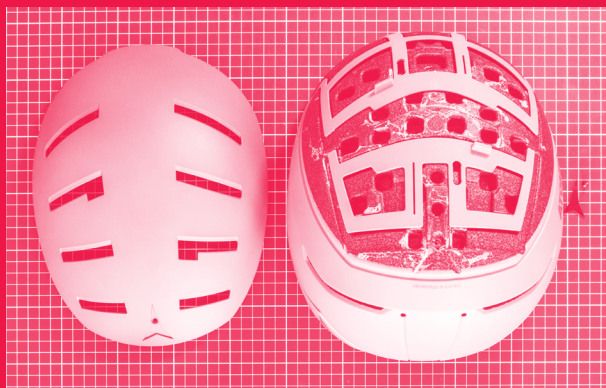

Fig. 70 – Destructive snap-fits in the Head Rachel helmet

6

The in-mold assembly — Paradigm shift and monstrous hybrid

RQ3.3 What is the current status regarding dis- & reassembly?

RQ3.4 What is the current ecological impact?

Another industry-standard, and considered as ski-helmet's latest 'paradigm-shift', is the in-mold construction. It consists of the EPS-liner, multiple different fixation parts in different materialities and (parts of) the helmet's shell, including the bottom ring. This subassembly is the core of the disassembly process and cannot be further taken apart, without tremendous time-consumption or fully destroying the parts.

It contains safety-critical parts, like the EPS-liner, the shells and chinstrap-fixation, but also parts with crucial value-perception, like the non-removable shells — This especially would create a large need for non-destructive removal.

In the case of the Savor GT AMID Visor model, the in-mold assembly is accountable for 37% of the total product-weight, 37% of the total embodied energy, 30% of the CO₂-footprint and 37% of the material-value, only on material level. Considering the removability of the top-shell in this model (as described in finding 6), this is considerably lower compared to products with fully in-molded shell, like the POC Fornix SPIN model, in which the in-molded liner has a weight portion of 65%.

In the definition of Braungart and McDonough (2017), this is considered a 'Monstrous Hybrid' and a large contradicting element to the concept of Cradle to Cradle and the Circular-Economy.

7

Five parts are accountable for 55% of the material-impact out of which, EPS can not be recycled.

RQ3.4 What is the current ecological impact?

RQ3.5 What are possible challenges regarding used materials?

The product's material makes 73% of the carbon footprint and 84% of embedded energy-level. Out of this, five parts are accountable for 55% of CO₂-footprint, 53% embodied energy and 58% of the material's value.

These parts, again are the EPS-liner, the PC- or ABS- shell-parts and the soft-liner — the main safety-critical priority-parts and priority-parts of crucial value-perception. A further problem is, that currently there are no processes in place, to lead the used EPS back into recycling processes. EPS can be recycled, but not in this configuration.

The soft-liner, with its dacron-textiles, its foam pads and the added merino-wool stands as an even truer example of Cradle to Cradle's monstrous hybrid, as it inseparably combines synthetic and natural materials.

8

Collections of product add-ons increase complexity, number of parts and materials and obstructs access to parts.

- RQ3.3 What is the current status regarding dis- & reassembly?
- RQ3.5 What are possible challenges regarding used materials?

Helmets address multiple different functions, from energy-management in linear impacts (EPS-Foam), oblique impacts (MIPS systems or proprietary options), fitting systems (BOA or other solutions) and other ergonomic parts. These systems are added to the product-base and lead to overcomplex structures with many materials involved. This was exemplary demonstrated in the case of the analysed Smith model (MIPS, BOA, Koroyd), with 52 individual parts, 19 different materials and 139 individual tasks needed for full disassembly.

The perpetual addition of features and layers within the product also leads to difficulties, as parts become obstructed to access. This either leads to high forces or precisions needed, or just to longer disassembly processes. This is also visible in the Head-model, where the fitting-system's dome is blocking many fixations.

9

Current alternatives either follow greenwashing, eco-design, or are inferior in quality or fully conceptual.

- RQ3.1 What is the current market situation on sustainable alternatives for ski-helmets?

EPS in in-mold constructions is the current standard for the production of helmets. Brands try to tackle the non-sustainable notion connected to this with either eco-design or greenwashing. They use blends of cork and EPS (monstrous hybrid), offer secondary EPS, sourced from bulk automotive-industry packaging, yet no post-consumer content. Others fund sustainable organisations to clear their image of being non-sustainable.

Other alternatives are either too conceptual, or inferior because of function or aesthetics. Folded-paper helmets are not equipped with a shell and secure fixations. Helmets with cardboard-structures (Fig. 72), until now, are heavy, provide inferior functionality or are not accepted by the user, because of their aesthetics.



Fig. 72 — Destructive snap-fits in the Head Rachel helmet

10

Most helmets are discarded after use and repair, refurbishment and remanufacturing of helmets is currently difficult.

RQ3.2 What are possible challenges with certification or legislation?

After users stop using their helmets, 76% of products are discarded, most likely leading to their incineration with minor downcycling of metals. 21% of helmets are being actively reused, either by friends or relatives or users buying these from second-hand marketplaces. Current legislation makes repair or refurbishment of safety-critical parts difficult, as only the usage of original materials and production processes are valid, a process that is currently difficult to facilitate, as OEM factories are located in China. Parts with crucial perceived-value, like soft-paddings can be replaced, but it is either not possible to remove these (chin-paddings), or spare parts are not available.

Organisations like CEN/CENELEC made first improvements to the repair, reuse and upgrade of energy-related products with the standard EN 45554. Progress in the field of personal-protective equipment, with strict regulations outweighing sustainable developments is currently in development. Policymakers, the industry and organisations like CEN/CENELEC or VSSÖ are involved in this. Yet, details are currently not available.

Manufacturers and marketers of sporting-goods are still following the classic long-life model of selling products to user, with little or no further connection during their product-lifecycle after the point of sale. Atomic still conducts their business fully in this way, yet it is expected that brands like Atomic will be made responsible for the end-of-life processes of their products in the future. This development, but also legislations on usage of primary plastics can further accelerate progress of sustainable development.

11

No greenwashing, no ocean plastics and no downgrade on safety, function or design — users want ‘real’ sustainability, as ‘must-have’ addition.

RQ2.4 What is the users current stance on sustainability within this product-category?

Sustainability is currently not an important criteria to buy helmets (rating 1,95 on a scale from one to six, where six signals the most importance), yet if it was clearly declared and comparable, and as real sustainable products would exist, customers would be interested in considering these products. (Increase to 3,7 on same scale)

Safety, functionality and design still has more importance, but as an addition, users would welcome more sustainable products. The conducted survey also made interesting opinions visible: Users are tired of greenwashing, green packaging, recycled contents and ocean plastics, they are under the opinion, that nowadays products should be sustainable anyways. Many users consider their helmets as sustainable products, as they use it for a long time. Some participants even stated, that they would be interested in solutions for take-back and sustainable services, if available.

12

Ski-helmets are currently not suitable for the Circular Economy!

RQ3 What is the current state of ski-helmets regarding the Circular Economy?

As previously stated, helmets are not monolithic-products, rather they are highly integrated products with different functions and parts being responsible for these. Helmets are safety critical, and as such are advised to be replaced in the event of a critical impact. However, helmets are also discarded because they show signs of wear and tear on their exterior parts and interaction elements, or develop an unpleasant perception of their textiles and paddings. These were defined as the parts with crucial perceived-value.

Currently, a failure in one of these parts, safety related or not, would ultimately lead to the full product's discarding, even as the helmet's safety properties or other parts would still be intact. Discarded helmets are most likely incinerated, and all value of resources and labour, that was built over time (as is indicated by the concept of the value hill) is lost, with only little regain of energy and additional CO₂ emitted.

This is mostly caused by the difficulty to dismantle the product to extract and replace crucial parts, and also ultimately recycle valuable materials to lower the total impact. Materials, including materials currently not suitable for the Circular Economy, like EPS, are inseparably joined with other materials and can never be easily brought back and their value kept intact.

Currently, the business-model of selling ski-helmets is a linear one, with most focus on providing an appealing product at the point of sale, and then provide no further services to maintain or extend its lifecycle.





5 CONCEPT & VISION

After investigating the possible fit of ski-helmets within the Circular Economy, a Vision is built to accommodate this gap of opportunity. The chapter outlines the concept and shows intermediate steps and their influence on sustainability. From Evolution to Revolution, from status quo to Circular Design.

5.1 CONCEPT STRATEGY 90

**Where do Ski-Helmets Fit?
Boundaries
Concept Strategy**

VISION STATEMENT 93

5.2 VISION OVERVIEW 97

**Airguard System
Design for Disassembly
Maintaining Product Value
Increasing Product Value**

**5.2 EVOLUTION &
REVOLUTION 100**

**Sustainable Evolution
Requirements**

5.1 CONCEPT STRATEGY

5.1.1 WHERE DO SKI-HELMETS FIT?

Most ski-helmets follow the 'classic long life' business-model of selling products with focus on the product as main component of value proposition. No further services are included and only few replacement parts available. Ski-helmets are located on the category lifecycle stage of maturity. Bakker et al. (2019) suggest, that for products in this business-model and category lifecycle stage, the transition should be made from 'classic long life' to the models 'hybrid', 'access' or 'performance'. These business models focus on accompanying the marketing of a tangible product with the increased marketing of services, from short-lived consumables (Hybrid) to a full product-service-system orientation (Performance).

The entry level stage into the Circular Economy is the usage of materials and product-architectures that are suitable for recycling. Recycling itself is considered merely the last step within this system, with other measures in place before.

Business-models that go further than 'business-as-usual plus recycling' are focusing on maintaining or improving the product integrity and therefore the product's value over time. These concepts focus on repair, refurbishment and remanufacturing and keeping products intact for as long as possible, including modular product-architectures that are able to update and upgrade. The longevity is subject to product health, but also to retrieving products pre-emptively to use them in refurbishment or remanufacturing, or when newer technologies are available. (den Hollander, 2018)

5.1.2 BOUNDARIES

Key finding 10 stated the current limitation of certification processes preventing sustainable business-models in ski-helmets. Repair of safety-crucial product parts, refurbishment, but also product-updates and aftermarket customisation that would include safety-crucial elements of the product is currently not possible because of connected liability issues. Replacing product parts that were subject to the certification process leads

to these liabilities being void. However, remanufacturing, if it was processed by the OEM, would be currently within the legal possibilities.

The importance of sustainably-designed personal protective equipment is currently increasing and different parties are involved in creating movement-space for better options in sustainable design within product certification of personal protective equipment.

5.1.3 CONCEPT STRATEGY

Taking in mind the current limitations, but also the possible future developments, the re-design concept focuses primarily on building a future vision on sustainable ski-helmets, with a timeline of around five years of industrialisation. In addition, a direction on an intermediate step should be proposed. (Fig. 73)

Following the proposed business-models of Bakker et al. (2019), the a direction was taken following parts of the 'classic long life' and 'hybrid'-models. The proposal focuses on introducing additional generated revenue through replacement parts and introducing aftermarket upgrades to counter the market-saturation in ski-helmets. This should drive product longevity and increase the perceived value, attachment and trust of the users. The proposal also focuses on increasing the company's control over its resources through gradually introducing recycling and remanufacturing. Lastly, impact should be decreased gradually, aiming at improving the environmental impact of the current baseline model.

Design interventions like design for standardization & compatibility, ease of maintenance & repair, upgradability & adaptability benefit these set goals. The focus on design for dis- & re-assembly drives all the before mentioned interventions.

Fig. 73 – Concept Strategy

From baseline-product to sustainable revolution — the proposed concepts focus on increasing product integrity, product value and decreasing environmental impact

	SAVOR	ECO SAVOR	AIR GUARD
Product Development Stage	Status quo	Sustainable Evolution	Sustainable Revolution
Maintaining & Increasing Value	Maintenance	Maintenance	Maintenance
		Update	Update
		Upgrade	Upgrade
Product Take-back System	No take-back system	Controlled take-back system	Controlled take-back system
		Recycling	Remanufacturing
Regaining Value			Recycling
Losing Value	Uncontrolled Disposal & Incineration		



Enabled by Design for Standardisation & Compatibility, Ease of Maintenance, Upgradability & Adaptability, Dis- & Re-assemble



Ski-helmets should be embedded into the Circular Economy, by **increasing the time of use of single parts, improving the ability to dis- and re-assemble the product, using sustainable materials only and providing users with a product that maintains and increases its value.**



Fig. 74 — Airguard-Concept
The concept-proposal for the sustainable revolution

ATOMIC

AIR
GUARD



CONCEPT & VISION

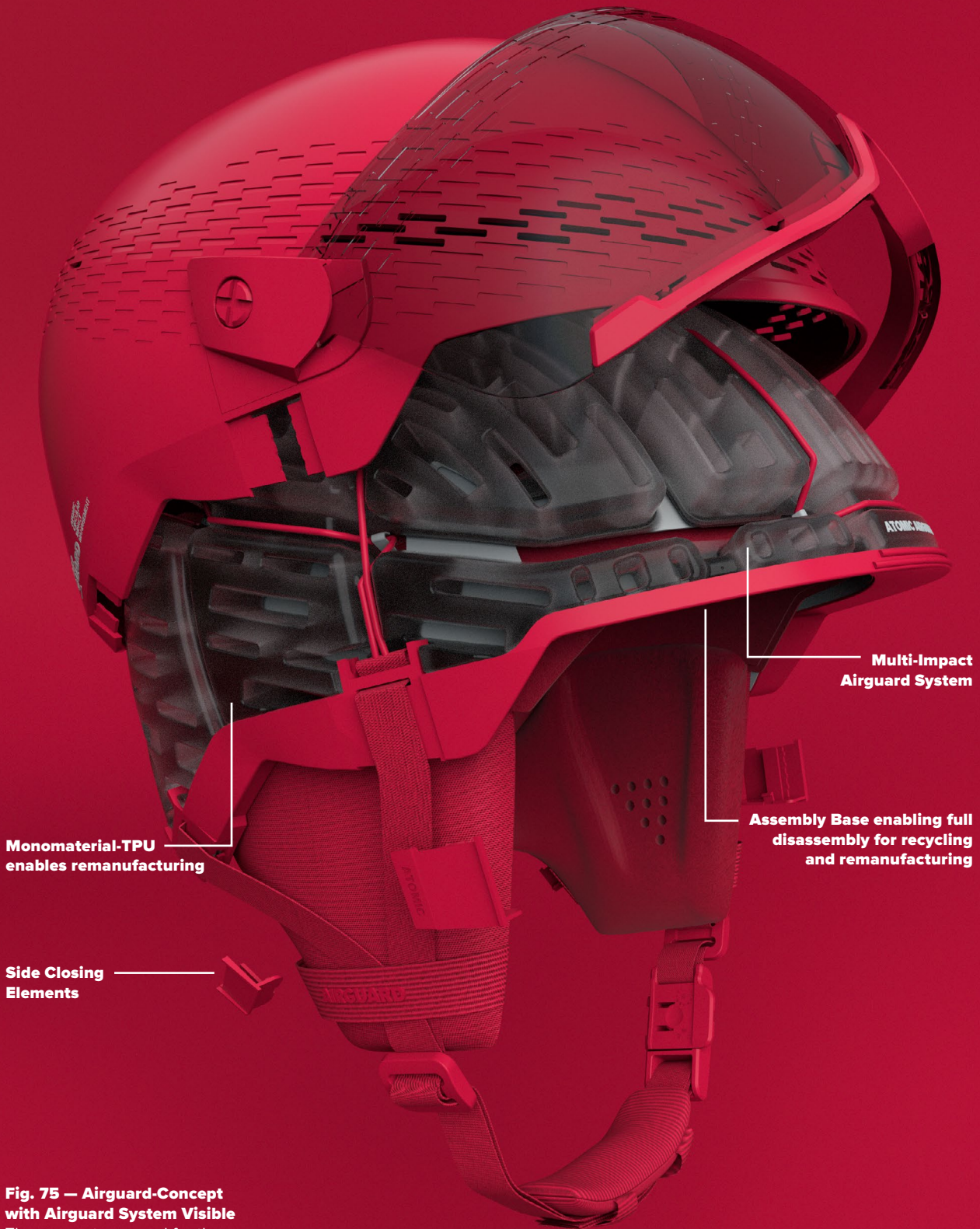

Fig. 75 — Airguard-Concept with Airguard System Visible
The concept-proposal for the sustainable revolution with the core technology — The TPU-airbladder structure

5.2 VISION OVERVIEW

The concept vision — the sustainable revolution — stands as a future concept for recycling and remanufacturing, but also updating and upgrading. Ideally, significant parts of the product could be remanufactured within new products by the OEM, going through the expertise of the OEM, decreasing their impact significantly. Additionally, it should provide a possible direction on improving product features like the single-impact property, both directional as well as oblique. Lastly, it should propose an inspiration on facilitating main functionality in ski-helmets, with possibilities of improving ergonomic fit and other features.

5.1.4 AIRGUARD SYSTEM

The vision-concept includes a novel form of energy-management — the Airguard system. It uses a network of air-filled TPU-bladders with hollow columns for deformation within impacts and defined orifices providing a controlled release of inside pressure. The Airguard system offers protection during multiple impacts, different impact velocities and oblique impacts. A large monomaterial TPU-structure is used, which is optimal for recycling. The TPU parts are easy to clean and offer durability that is beneficial for product longevity and remanufacturing.

5.1.5 DESIGN FOR DISASSEMBLY

The sustainable revolution concept builds onto a product architecture that is fully disassemblable. It follows the requirements of making safety crucial parts only accessible through the hardshell and only giving users access to ergonomic parts, like visor exchanges and removing the soft-liner.

The full assembly can be taken apart within 36 actions (compared to 53 in the baseline-model Atomic Savor GT AMID Visor), by only using hands and a lever/prybar tool. The product assembly is designed for integrating fixation elements into multi-functional fixation compounds, reducing the total number of parts- and materials to support recycling and product remanufacturing.

CONCEPT & VISION

5.2.1 MAINTAINING PRODUCT VALUE

The concept aims at maintaining product value and improving product longevity. Single parts should stay in use as long as their part-health allows and options should be available to not discard full helmets because of single broken parts. Parts that are linked to crucial value-perception, yet are not connected to safety crucial functionality, like soft liners and visors can be easily removed, cleaned and replaced by the user. Once products are no longer used, a product take back program should be put in place, motivating users to send back products to the OEM rather than discarding them. The OEM can then disassemble these products, assess their health and either put them in controlled recycling or use defined product parts for remanufacturing. Parts used for this represent big parts with the majority of impact, yet also parts that are not subject to deterioration.

5.2.2 INCREASING PRODUCT VALUE

To increase the product value while still in use, the concept offers a product architecture that enables functional upgrades. The product can be used with only goggles — visors can be attached to it — yet also equipment like headlamp-holders or chin guards for racing.

Shell parts — the helmet's exterior — are safety-critical, yet also parts that lead to emotional obsolescence and decrease in perceived-value. They are subject to scratches, denting and paint that becomes sticky through external influences like UV radiation or cleaning agents. The hardshell can be removed by the OEM or authorized third parties, after which updated hardshells can be set in place to replace old, worn ones or to accommodate new aesthetic trends. These measures should prevent helmets being discarded because different functionalities are needed or the old item is not considered as pleasant anymore. This feature however would demand a change of current regulation processes.

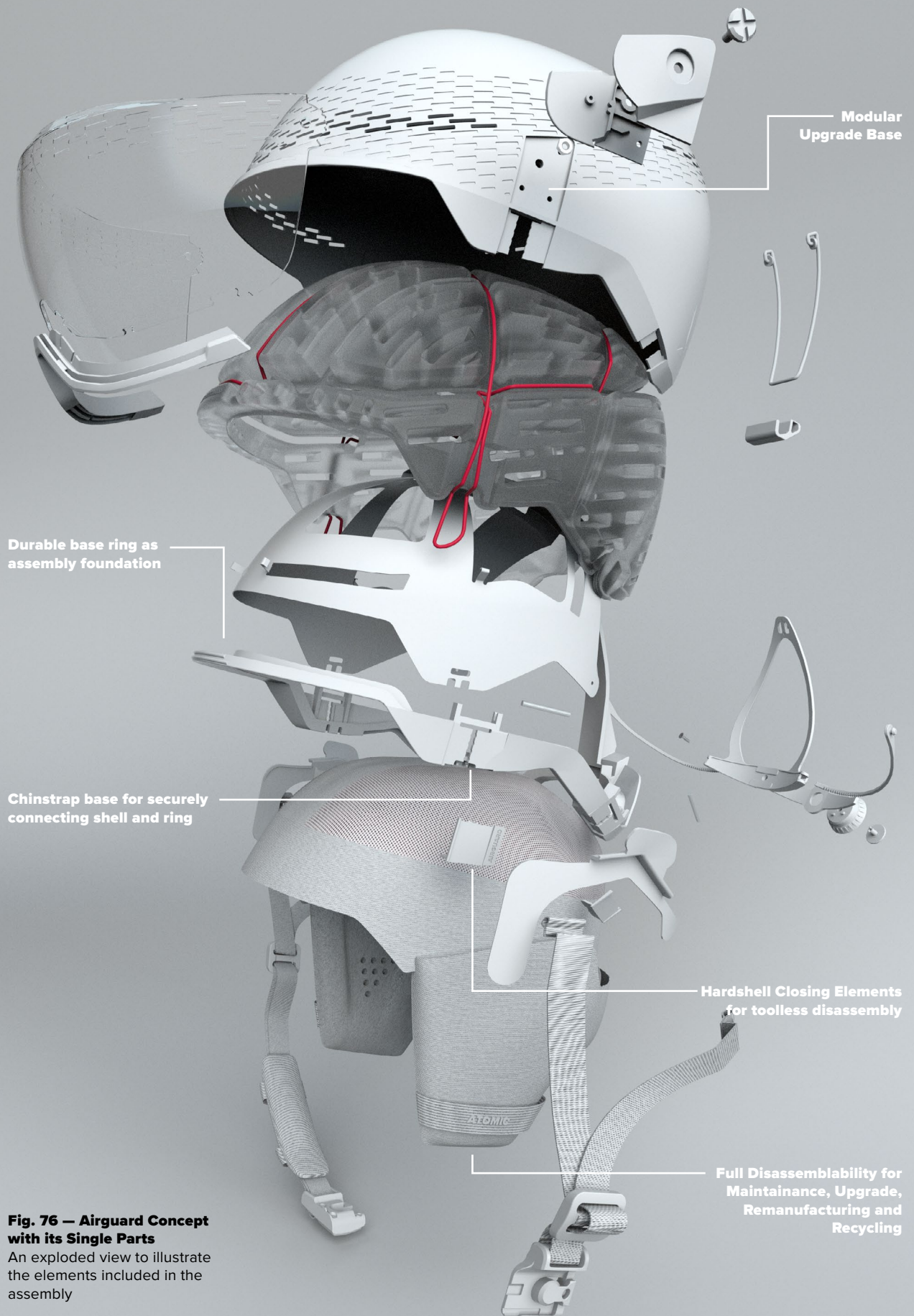

Fig. 76 — Airguard Concept with its Single Parts

An exploded view to illustrate the elements included in the assembly

5.3 EVOLUTION & REVOLUTION



ECO SAVOR

5.3.1 SUSTAINABLE EVOLUTION

Having this vision in mind, an intermediate step — the Eco-Savor — a sustainable evolution should be the first development step towards sustainability within the currently known product-archetype. It should be seen as a near-future, feasible option. It focuses on recyclability by improving the product architecture, while still relying on the known product functionality. Yet, it should also lay the base of product-architecture development towards the vi-

sion, e.g. assembly and disassembly principles for the future-vision should already be tested on this concept stage, ultimately leading to continuing improvements. Furthermore, it should help building expertise on durability of parts later used in the remanufacturing process. The timeline for this intervention would be around one or two years of industrialisation.

Fig. 77 — Airguard and Eco-Savor Concepts

The Eco-Savor is still using EPS foam, while the Airguard uses a different approach on energy management. Both rely on the same assembly base.

**AIR
GUARD**

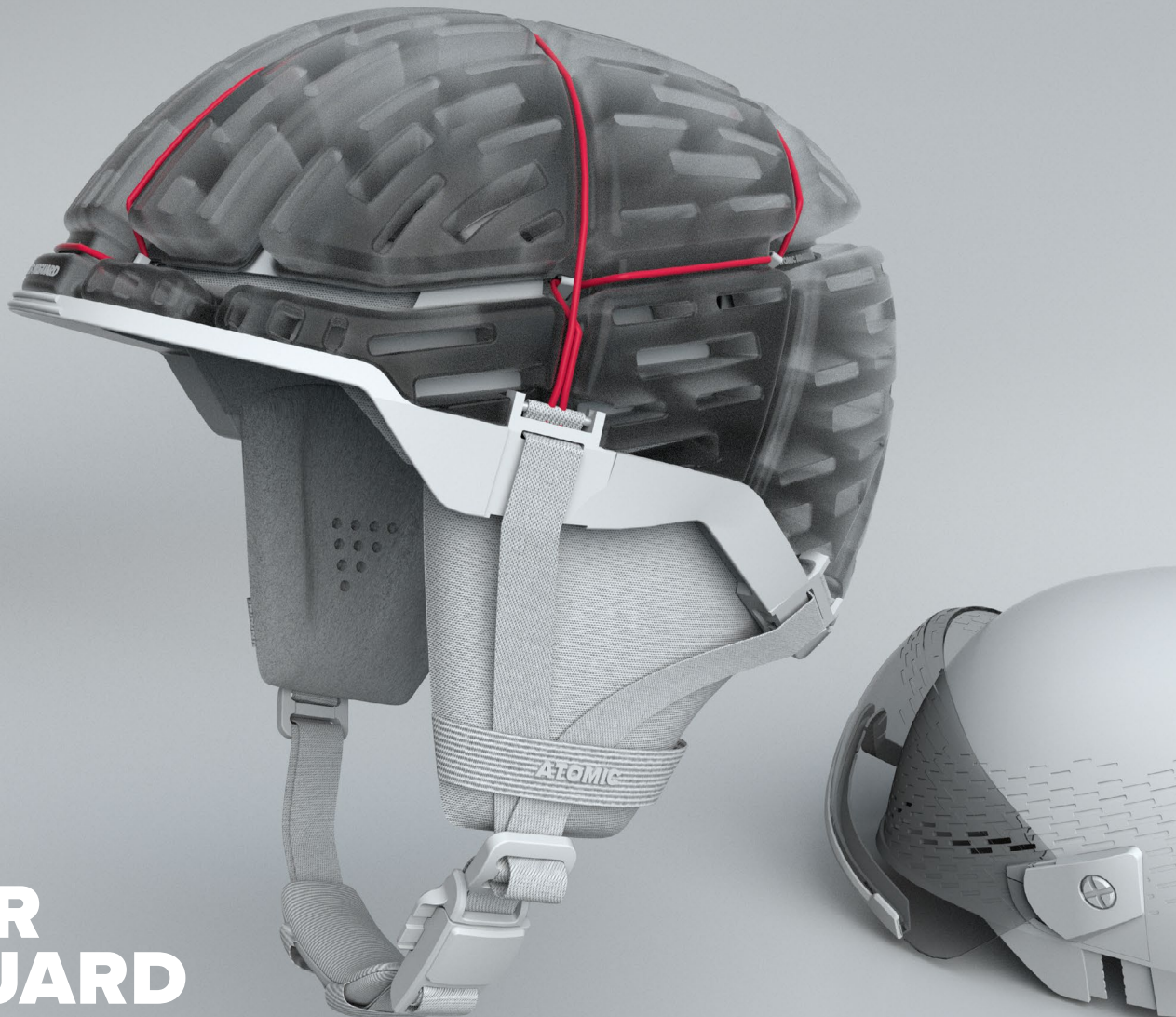

CONCEPT & VISION

5.3.2 REQUIREMENTS

To make ski-helmets fit into the proposed concept, certain requirements need to be met. These can be separated in requirements for the safety crucial functionality, the product's value, including the parts with crucial value perception, the product architecture and the product's materials and resulting impact. (Tab. 4)

Due to the conceptual nature of the project, with focus on proposing a vision on the sustainable re-design of ski-helmets, with an industrialisation time of five years, these requirements are defined with no hard numbers assigned to them — yet. For the time being, and with the possibility of proposing a whole new providing of the safety-critical functionality, they should stand as a guideline for further re-design processes.

Tab. 4 – Main requirements

Conceptual-requirements, in different categories show the framework the re-designed product should follow, and its sustainable targets.

Category	ID	Requirement
Safety crucial functionality	SC1	Safety above all else.
	SC2	Multi-use above single-impact.
	SC3	Product health should be known at all time.
	SC4	Safety critical parts must be fully removable.
	SC5	Safety critical parts should not be removable by the average user.
Product value	PV1	Keep product integrity intact for as long as possible.
	PV2	Interior parts should be removable by the user.
	PV3	Shell parts must be fully removable.
	PV4	Shell parts should not be removable by the average user.
Product architecture	AR1	All parts of different materiality must be fully separable.
	AR2	Functional groups, like fitting-systems, should be removable together.
	AR3	The number of total parts should be reduced.*
	AR4	The number of different steps should be reduced.*
	AR5	The number of total tasks should be reduced.*
	AR6	The number of different fasteners should be reduced.*
	AR7	All fasteners should be easily reachable, without using complicated shortcuts.
	AR8	The number of different tools used should be decreased.*
Materials and impact	MI1	The number of total materials should be decreased.*
	MI2	Only materials suitable for the Circular Economy should be used.
		* improvements refer to the Atomic Savor GT AMID Visor, as baseline product





6 DESIGN

This chapter focuses on the outcome and the development steps of re-designing the baseline model into the Eco-Savor and Airguard concepts — From stating the proposals to evaluating them.

6.1 AIRGUARD SYSTEM	108	6.6 AIRGUARD SHELL	160
Impact Energy Management			
Monomaterial Structure			
Case Studies			
Concept Testing			
Concept Development		6.7 SUSTAINABLE EVOLUTION	164
6.2 RE-DESIGN FOR DISASSEMBLY	120		
Hardshell Access			
Airguard Subassembly			
Functional Base			
6.3 MAINTAINING PRODUCT (PART) VALUE	135		
User Access			
Recycling			
Remanufacturing			
Take-Back System			
6.4 INCREASING PRODUCT VALUE	144		
6.5 RE-DESIGN EVALUATION	146		
HotSpot Analysis			
Disassembly Map			
Product Weight			
Ecological Impact & Economic Value			
End of Use & End of Life Scenarios			
Technology Readiness			

6.1 AIRGUARD SYSTEM

6.1.1 IMPACT ENERGY MANAGEMENT

The Airguard system is the concept for a new energy management system, used within this helmet-redesign to replace the EPS-liner. The system is comprised of an integrated system of air-bladders and an inside structure with radial hollow columns in two opposing directions. The air-bladders are open to the outside atmosphere — small defined holes allow air to travel.

Impact energy management is facilitated through a combination of structural deformation of the system’s inside columns and air flowing to the outside of the bladder through holes, triggered by the increase of inside air-pressure following the bladder being compressed. (Fig. 78)

Dual Bladder-System

The system within this concept includes two air-bladders, as a proposal for providing protection against different impact velocities. The outside air-bladder is designed to give the helmet its main contour, therefore having an almost constant thickness of 19mm. This can also cater to high velocities and giving more structural stability. On the inside, at a smaller area, closest to the user’s head, a thinner bladder can be placed. The thin extent, but also a different inside structure, can provide safety against low velocities and adapt to the headform of the user. The usage of two air-bladders allows using a more dynamic shape of the helmet, which would be less ‘balloon-like’ (analogue to using variable thicknesses of EPS to create these shapes). Multi-velocity impact protection is currently achieved by using different densities of foam within one integrated foam-liner. (helmets.org, n.d.-3)

The concept includes a defined array of cushioning bodies with inside structure, and thinner, transition elements to create better head-fit.

Oblique Impacts

Bi-directional radial elastic columns provide protection from oblique impacts. Through the connecting hollow columns, the structure on the user’s side can move in different velocities and directions than the opposing side, creating a sliding plane effect, commonly found in other oblique

impact systems. (Fig. 78; bottom image) Furthermore, the vessels are connected to the helmet’s assembly through elastic TPU-cords, creating more protection from oblique-impacts.

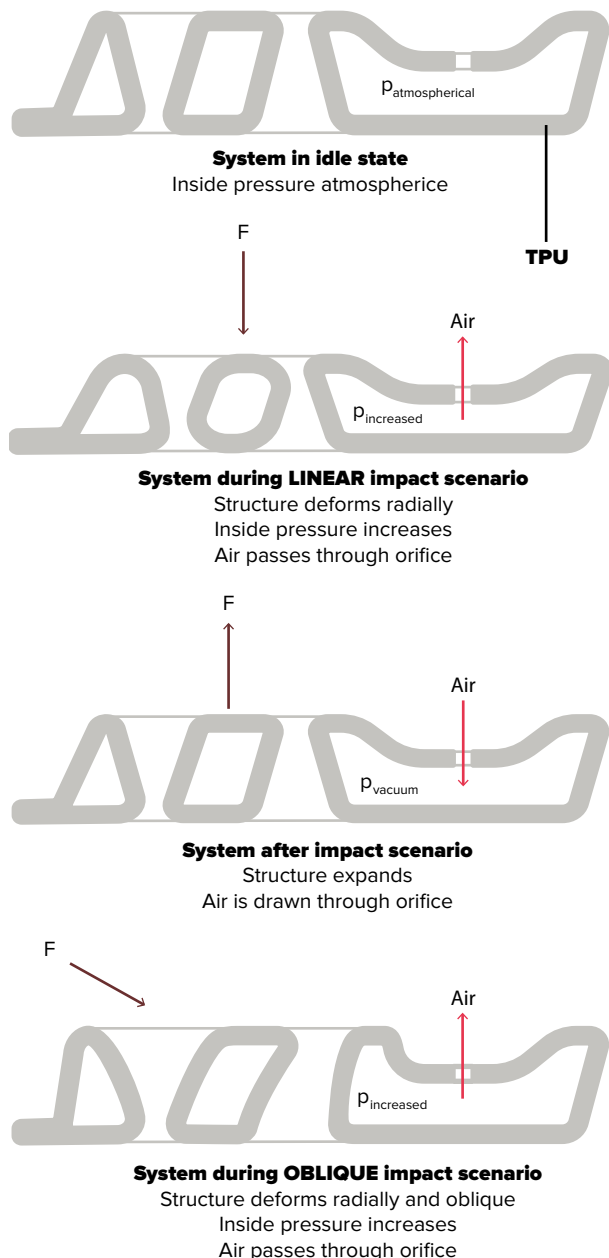

Fig. 78 — Airguard function schematic

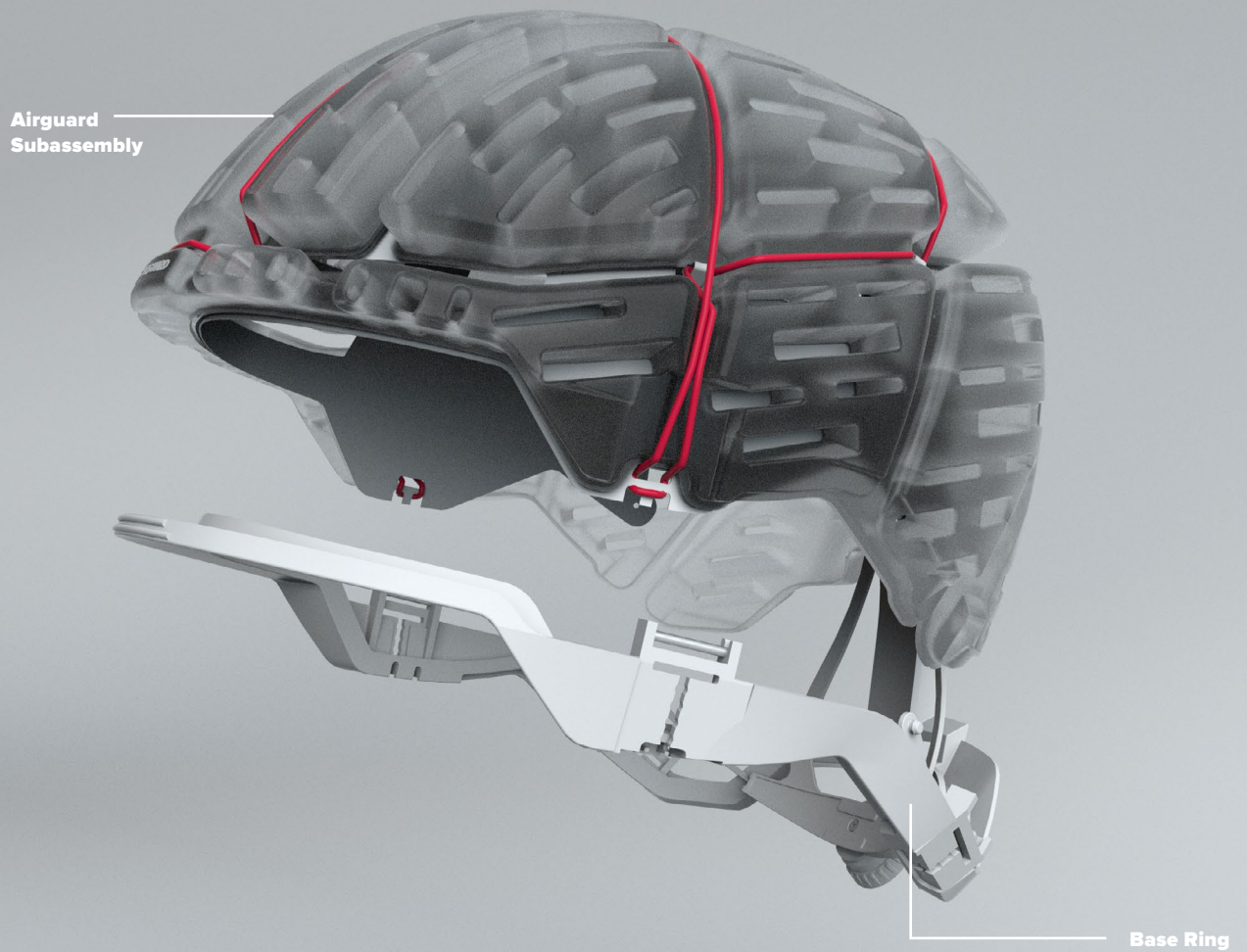

Fig. 79 – The Airguard-system with mounting base
The structure with its two bladders forms a subassembly that is mounted to the helmet's Base-Ring element.

DESIGN

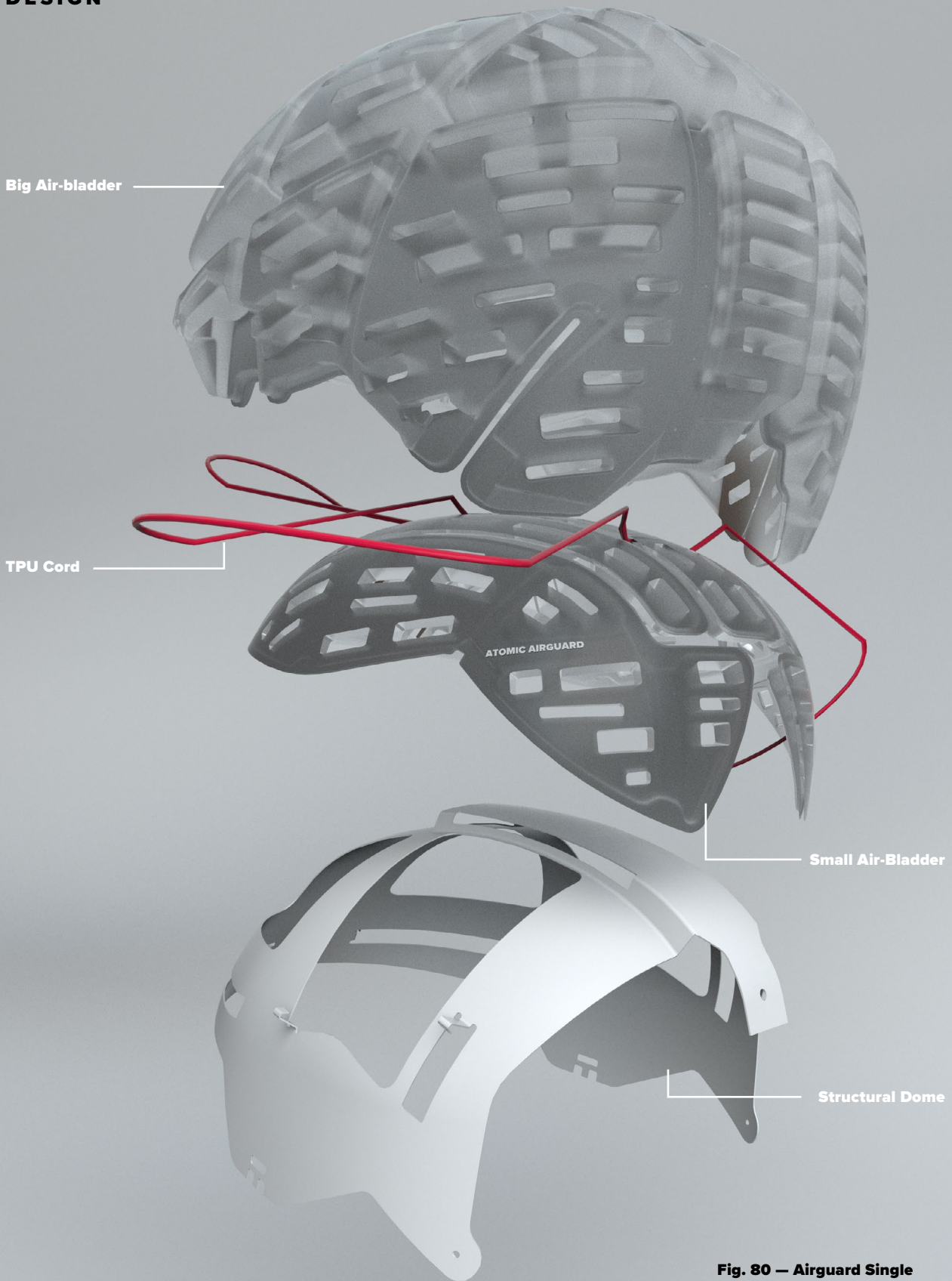

Fig. 80 – Airguard Single Parts The system in exploded view showing both bladders, the holding elastic TPU-cord and the structural dome on which the system is mounted.

Ventilation

The hollow columns allow the opening of a large area of the helmet's liner. This is a great feature for ventilation and letting sweat and body temperature be transported from the user's head in warm temperatures or high levels of activity.

Multi-use

After an impact occurred, the elastic properties of the structure will realign in their original position. This creates low atmospheric pressure and drawing air back into the air-bladder. It opens the possibility for helmets not being rendered useless after a single impact-scenario and to re-use the structure in remanufacturing.

6.1.2 MONOMATERIAL STRUCTURE

The full structure is made from monomaterial TPU. The outside shell and the walls of the hollow columns are made from the same sheet of TPU-material. The structure is produced flat, with two sides of tools and an attached inside pressure, guiding the material to the side of the tools. In a thermoforming-process, the two sheets of material are brought into shape and then welded to be airtight. The defined orifices can be lasercut or stamped prior to thermoforming. (Fig. 81)

Fig. 81 — Top and Bottom side of the Flat Airbladder

Schematic visualisation showing top- and bottom of the big airbladder in flat orientation.

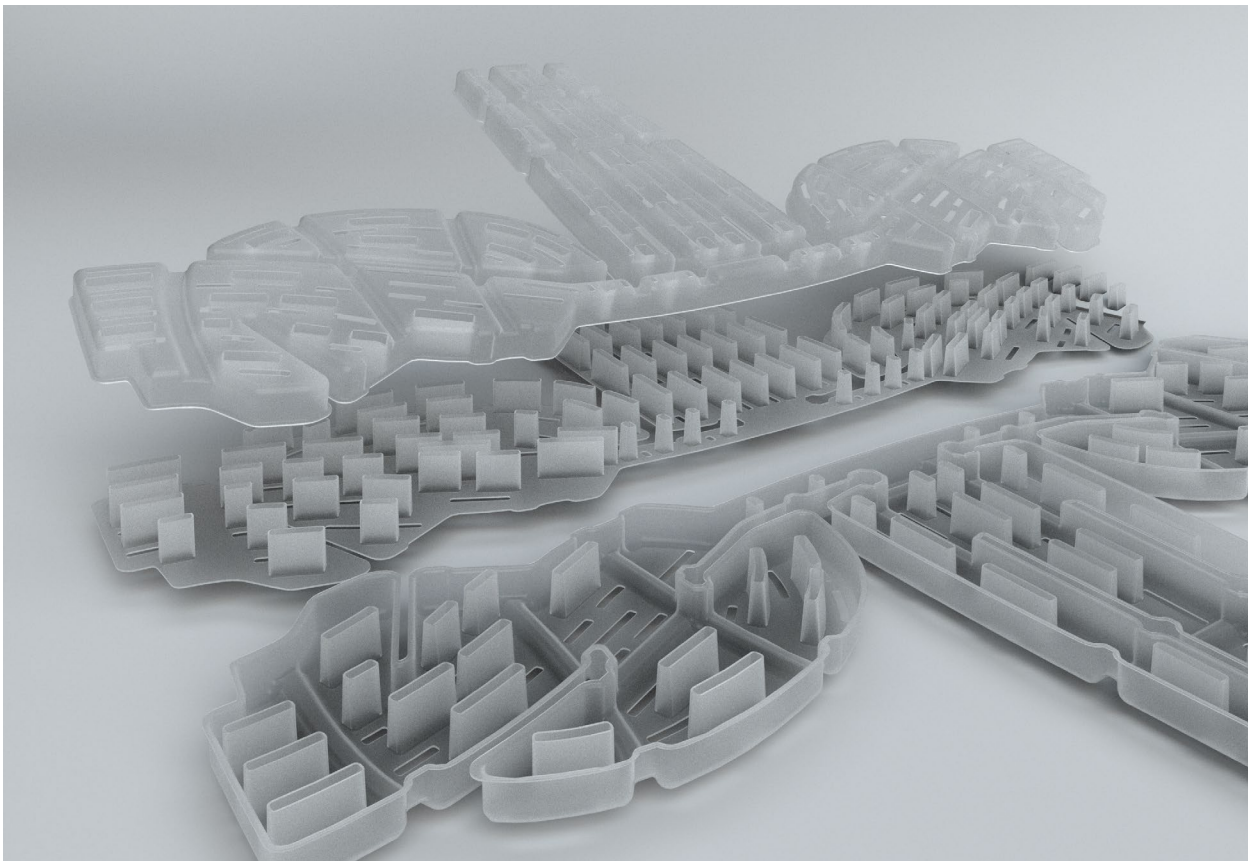

DESIGN

6.1.3 CASE-STUDIES

The Airguard concept is based on findings made in previous research and case-studies:

Schutt TPU Cushioning

The inside system takes inspiration in an approach used in football-helmets, sold by the company Schutt since 2003, in multiple technology generations. The company equips 37% of players within the United States National Football Association (NFL) with helmets and protective gear. (Schutt, 2017-1) Within Schutt's helmets, a TPU structure with radial columns in opposing directions is attached to the inside of the helmet's shell. (Fig. 82) Their proposal is that the deforming TPU structure has better impact management properties than foam parts usually used within football-helmets. It should supersede traditional foam-structures by 45% more impact absorbed. Furthermore, Schutt claims that their TPU-parts are virtually not afflicted by changes in protection properties in hot and cold temperatures, while offering great cooling through not using insulating foam.

The combination of TPU's elasticity and the hollow columns used within the structure allows the padding to retake it's original shape, yet not to bounce back immediately. The structure shows no compression-set, even after thousands of impacts and does not demand a break-in period as it provide instant fit to the user's head.

The TPU-parts can withstand sweat and other influences that lead to their further deterioration and can be easily cleaned to recondition the helmet. The TPU used in Schutt's helmets is impervious to mold, mildew, fungi and bacteria and the it rarely needs to be replaced, if ever (as claimed by the manufacturer). (Schutt, 2012)

Schutt offers full reconditioning of their helmets, with all interior parts removed, checked and cleaned, with the possibility of replacement with new OEM parts. The reconditioning may include polishing and re-painting shells and re-issuing the helmets with certification stickers and season labels. (Schutt, 2017-2)

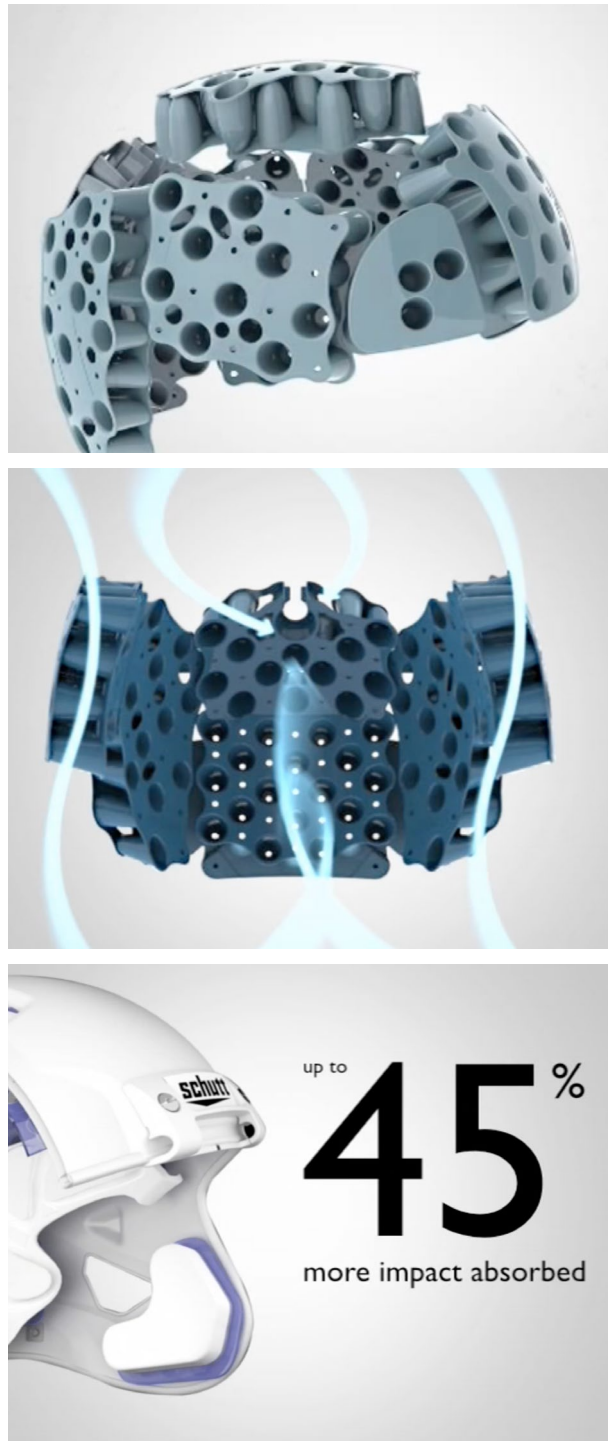

Fig. 82 — Schutt TPU-Impact management system (Schutt, 2012)

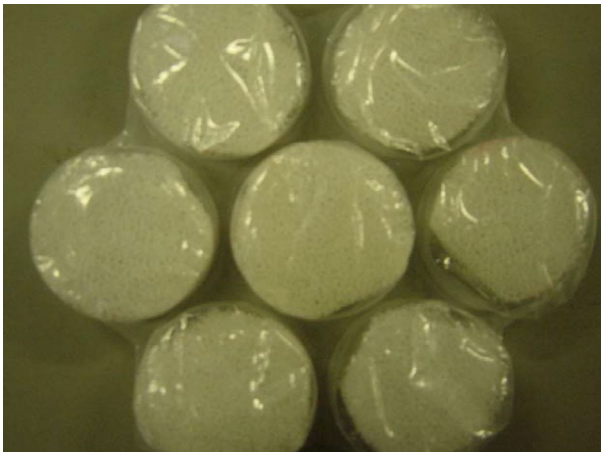

Fig. 83 — Baseline testing sample of foam-filled air-bladders with orifices (Tanaka et al., 2009)

Leak Allowed Air-Cushion for Hip-Protection

Using holes to transform impact energy and to decrease acting acceleration was subject to research by Tanaka et al. (2009). The research focused on testing different hip-protecting equipment, e.g. for elderly people with fragile hips. The group would inspect hip-protectors using closed air-filled bubbles, comparable to bubble-wrapping foil used in packaging, filled with Polyurethane foam. (Fig. 83) After testing acceleration forces with these structures, orifices were pinched into the vessels. One testing analysed a setup with a single orifice, with different diameters between 0,5mm and 3mm. The next testing focused on multiple holes with a set dimension of 0,5mm, with a number between one to 36 holes.

The key findings of this paper was that, for the investigated volume, the impact attenuation ‘sweet-spot’ was reached at a orifice diameter of 1,5mm (Fig. 84) and at a number of 25 holes with a diameter of 0,5mm. (Fig. 85) This therefore points towards large increases of impact-managing performance with the right dimension and pattern of holes and the possibility to improve such a structure largely.

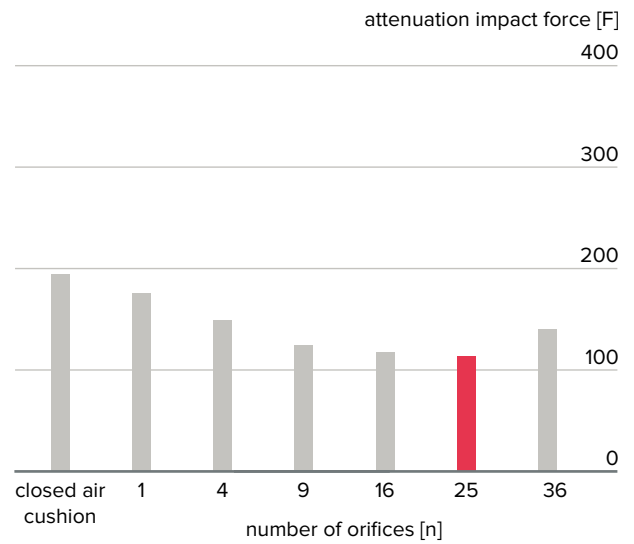

Fig. 84 — Impact attenuation of air-bladders with different diameters of orifices

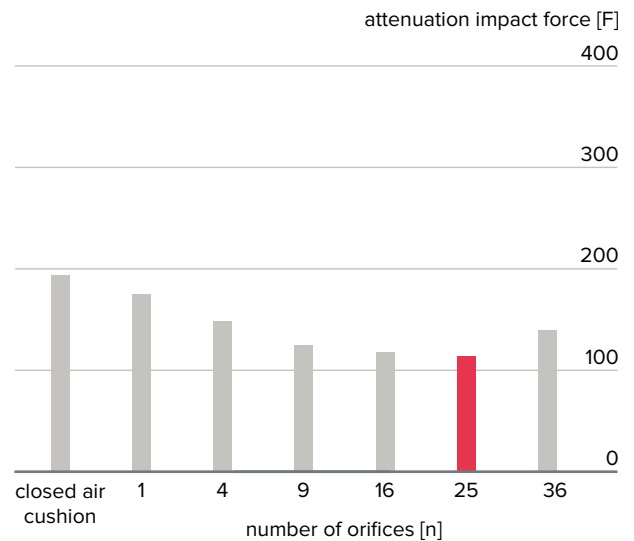

Fig. 85 — Impact attenuation of air-bladders with different numbers of orifices

DESIGN

6.1.4 CONCEPT TESTING

To get a better view on the feasibility of concept, an experimental test was conducted, with the help of two Chinese companies. One of these companies is specialised in producing TPU air-bladders, another one is one of the leading manufacturers of helmets, and therefore has a testing-laboratory with industry standard machinery on their disposal.

Tested configurations

The test should be used to test air-bladders with different inside structures against the same inside structures without an air-bladder involved. These samples were placed in-between a textile cloth, representing a soft liner and a piece of flat PC, representing a helmet's shell. The air-bladders were equipped with a hole, yet the hole diameter was undefined, as the insights produced by the Japanese researchers were not known at this point. All samples were made in a similar thickness of 30mm, as a maximum thickness commonly found in helmets. The setup included:

- Impact Absorption foam
- Impact absorption foam in an air-bladder, with a hole (Fig. 86)
- EPS as benchmark

Testing setup

The samples were placed on a testing machine, usually used for testing helmet's suitability for certification standards like EN 1077 or ASTM 2040. The samples were attached to the top part of the testing apparatus, where usually the headform and the helmet would be mounted. (Fig. 87)

Procedure

The samples were then dropped from 100cm and 200cm onto a flat anvil. 200cm represent the standardized dropping height within the ASTM standard, which is 50cm above the dropping height in the EN standard. The acceleration values were measured and plotted within a testing documentation. (Fig. 88)

Results

The acceleration values deduced from the testing signalled, that the benchmark technology — the EPS — has consistent properties in spreading the energy over a wide timeframe and therefore taking off peak G-forces in an impact scenario. Especially in the case of drop-height 200cm, the EPS



Fig. 86 — Samples prepared for the concept testing



Fig. 87 — Concept testing setup

is clearly superior to the other samples. At this height, the impact absorption foam led to G-forces at almost 400G. Interestingly, the same foam, located within the air-bladder with a punctured hole decreased the impact acceleration by 50G.

At a drop-height of 100cm the shock-absorption foam set the lowest score, with 96G reaching the sensor, compared to 123G in a comparable EPS configuration.

The produced testings clearly indicate the current superiority of EPS within these scenarios. However, they resulted in proving that the air-bladder does have an effect, when comparing the setup to a piece of impact absorption foam without the hull. Furthermore, the low-velocity scenario resulted in a safer acceleration, compared with normal EPS.

The testing produced a strong signal, that the assumptions made can lead to feasible solutions using mono-material airbladders with inside impact-managing structures in the future. Lastly, EPS is the main material of helmet-construction for decades now. It can be assumed, that within this long period, countless improvement-measures were taken to engineer the material to fulfil its function as good as possible. A new concept-idea is very unlikely to yield better results on first try. Further development and tuning of the material properties and geometrics used might lead to large steps of improvement.

Fig. 88 – Accelerations measured in different testing samples

Measured G-forces of different samples, from different heights

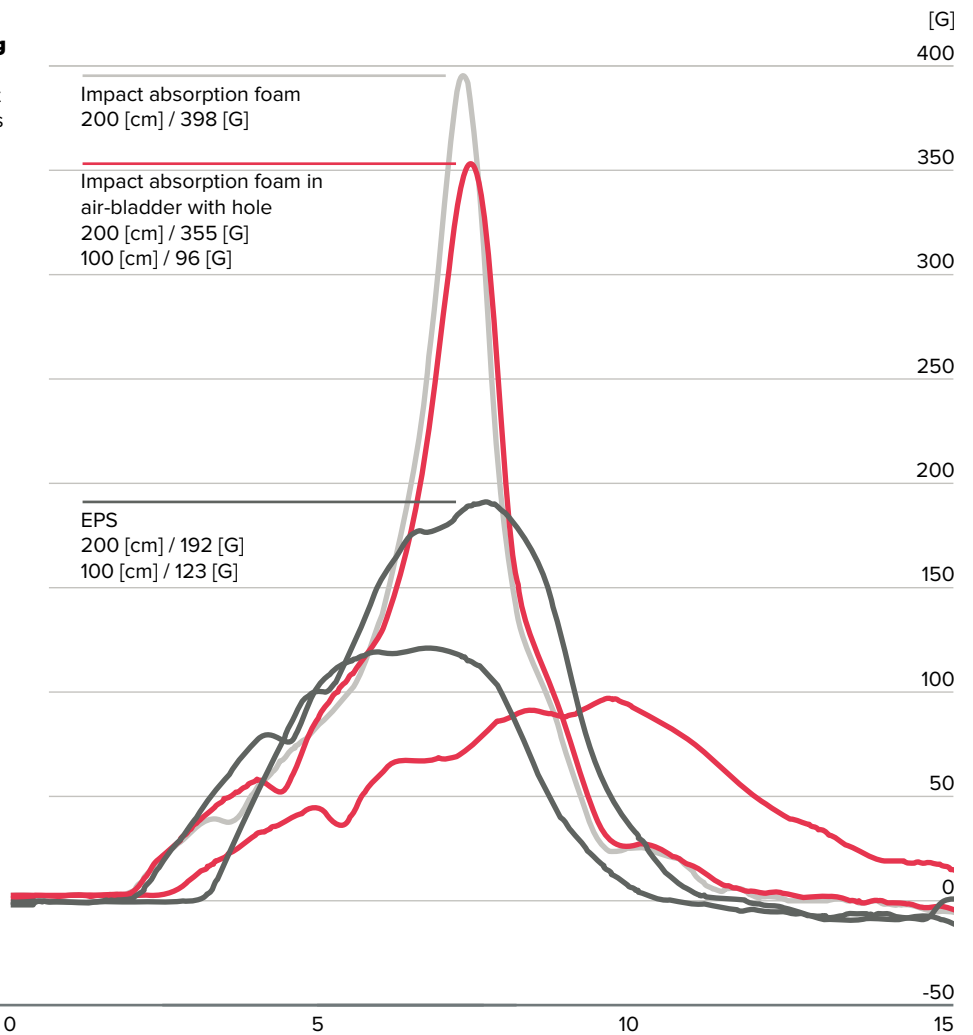

DESIGN

6.1.5 CONCEPT DEVELOPMENT

Brainwriting-Method

The Airguard concept is the outcome of a conceptualization process, looking for a replacement of the EPS in-mold assembly. Out of the defined requirements, AR1 & MI2 focus on either making all materials separable or only using materials that are suitable for the Circular Economy. The EPS-liner is the industry-standard and a crucial element in current ski-helmets. One of the challenges therefore focused on replacing this part with a sustainable option, suitable for use in the CE, in a five-year timeline for industrialisation. The concept should stand as a vision and the decision was made to refrain from using mere material-replacements of the EPS foam, but to take an exploratory direction.

For the five-years timeline, the replacement should focus on solutions outside of only replacing the EPS-material with an alternative foam, but to rethink energy-management in its entirety. To open up the idea-finding process, a creative session was facilitated, including five Master-students of Integrated Product Design, from the faculty of Industrial Design Engineering at the University of Technology in Delft.

The method used for this session was the 6-3-5 brainwriting method, a structured approach on brainstorming — An example of the results is shown in Fig. 88, the results can be found in Appendix H.

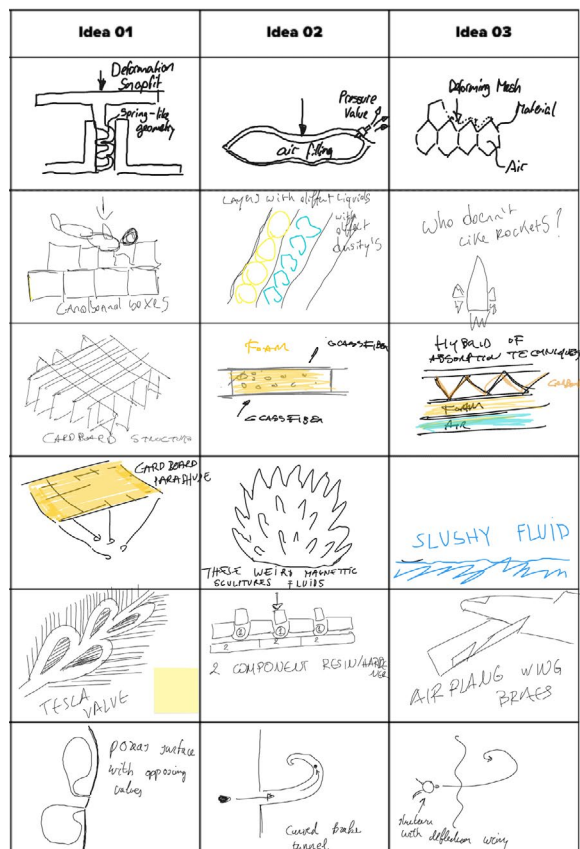
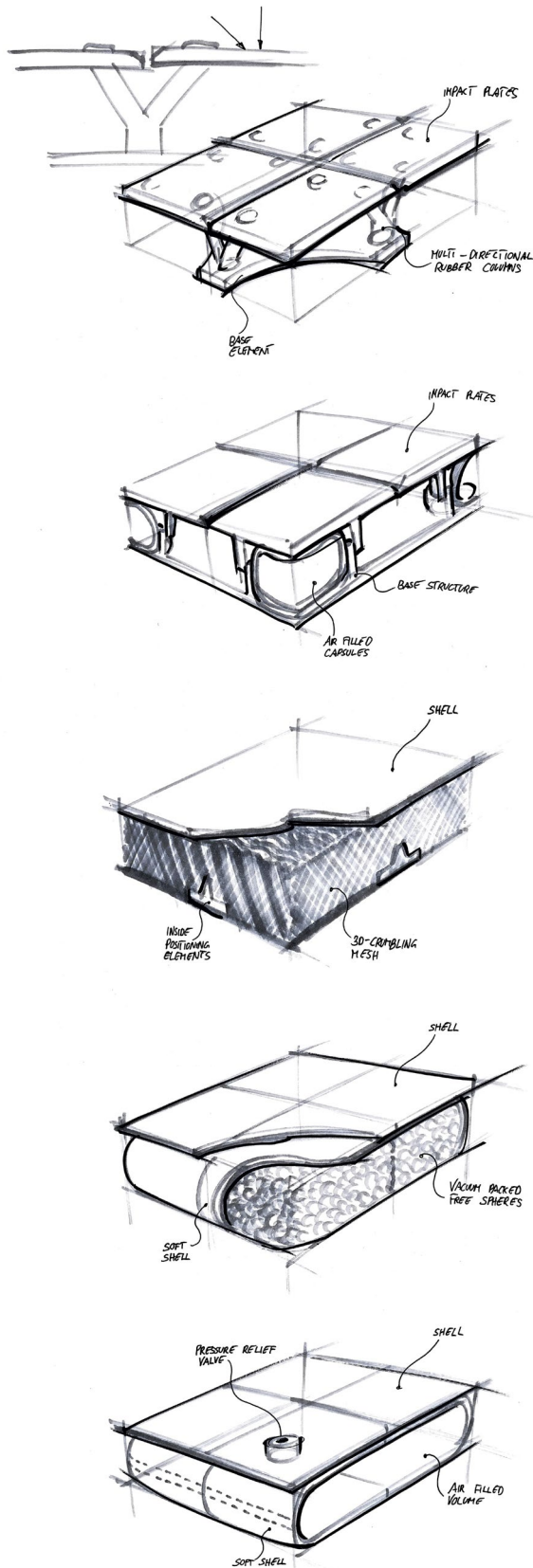

Fig. 89 — Brainwriting method result

One of the results of the brainwriting method, showing a variety of ideas, on one out of six pages.



Energy management ideation

After analysing the results of the creative session, first concept-ideas were developed, visualised and discussed with the project’s mentors, both on the sides of the company, and the university.

Fig. 90 shows parts of the idea-collection process from the brainstorming with interesting ideas further developed. These ranged from decelerating movement through rubber columns (top), through crushing mesh structures (middle), using free-moving plastic beads, held in place by a vacuum (second from bottom) to the bottom image, showing an idea involving an air-bladder, in this stage equipped with a pressure relief valve. The collected and visualised ideas were then discussed with the client company, aiming at gaining more insight on the idea’s first appeal. Within this communication, it became apparent, that most concept ideas were already tried on the market, and failed or seemed too expensive or subject to other boundaries like unsuitable fit, weight or failure in delivering proper impact management. (Wirthenstätter, 31.03.2021, Appendix B)

An idea worth pursuing, and interesting because of multiple reasons, including weight, simplicity, possible benefits for sustainability and the fact that it wasn’t tried before on the market was the idea involving an air-bladder system.

Fig. 90 – Alternative energy management techniques

Schematic drawings of different possibilities to decelerate an impact movement

DESIGN

Airguard development

Fig. 91 shows different ideation and conceptualization steps that led to the concept proposed within this thesis. The concept evolved from using an air-bladder without an inside structure, yet using a pressure-relief valve to open at a set pressure level and close at another set pressure level. The initial concept had numerous potential challenges to encounter, which the current concept aims at solving:

- The closed air-vessel would likely change its functional behaviour (and volume) in different atmosphere pressures at different elevation levels;
- The bladder can be punctuated and seizes its functioning;
- The bladder would need an active re-pump once the valve was activated, or it would need a very complicated schematic to re pump automatically;
- Letting the user do the re-pump would be questionable in terms of liabilities, using a third party would create a complicated process;
- The bladder with only air-filling would be very difficult to fit into the surrounding product architecture, as it is unstable;
- The bladder and valve would create a complex structure, with many mechanical developments needed.

The latest concept stage of Airguard provides an open system, which is not (or to much smaller extent) prone to different altitudes as the system is open to the atmosphere. The bladder has an inside structure and pre-defined open holes. A punctuation would alter the functionality, yet less than a closed system. The elasticity of the airbladder automatically re-pumps the bladder, without any outside mechanism needed. The structure made from stable TPU can follow geometries, steps, ribs and other structural elements and can be easily fit into the surrounding structure. Lastly, the system is made from monomaterial TPU with holes that can be easily cut with a laser or a stamping tool.

Fig. 91 — Air-tech with inside air-bladder Collection of visualisations of the air-bladder's development process and how it could provide safety, fit and ventilation.

AIRGUARD SYSTEM

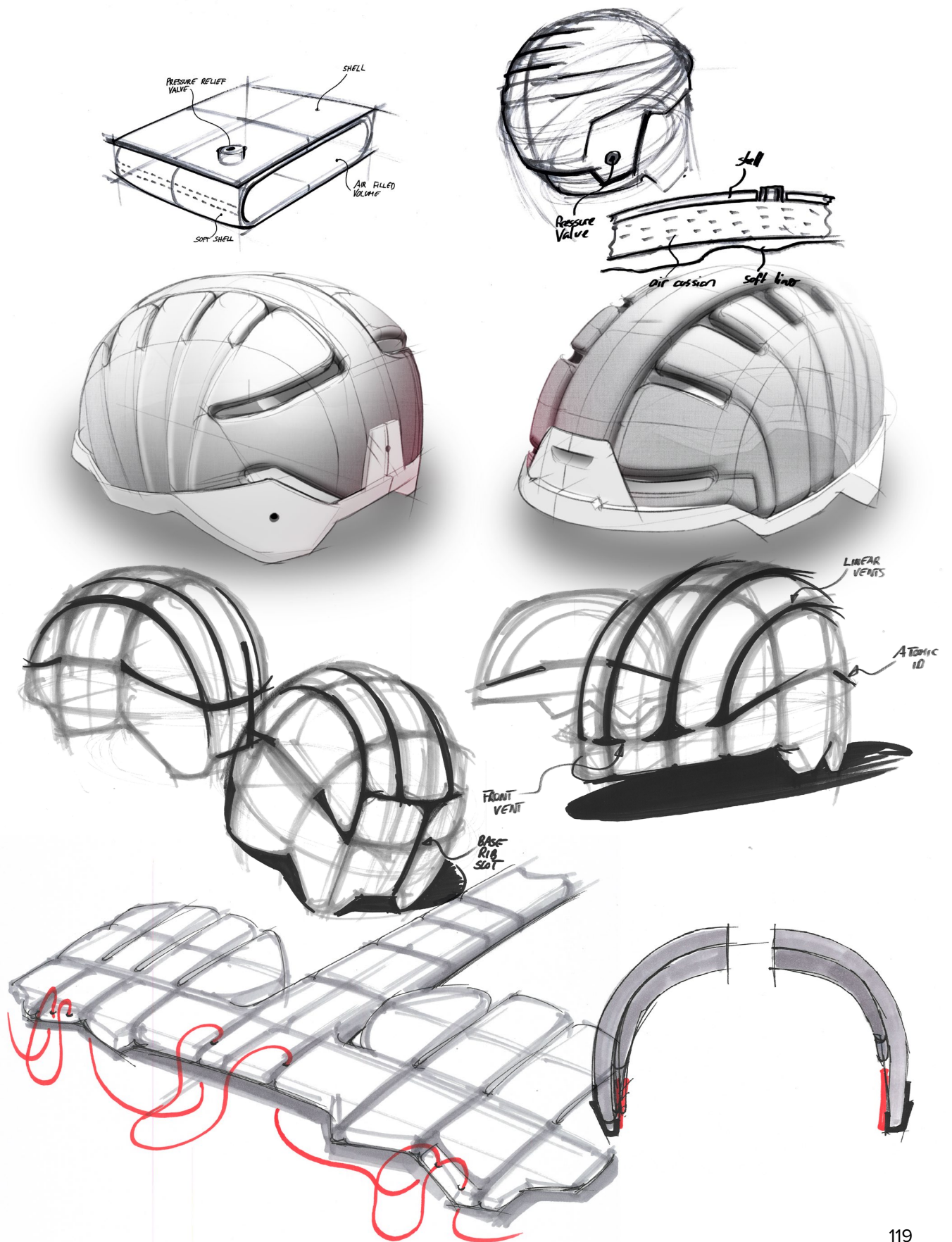

6.2 RE-DESIGN FOR DISASSEMBLY

6.2.1 HARDSHELL ACCESS

A main priority for the re-design of the product architecture was incorporating all safety crucial parts, yet also making them accessible for assembly and disassembly by authorized experts. Average users, on the other hand, should be prevented from accessing safety crucial parts.

Access to safety crucial priority parts

The decision was made to make all safety-crucial parts accessible by removing the hardshell, as the main closing element. The hardshell should be in place for delivering impact energy over a large inside area, yet also for protection against penetrating objects. The hard-shell is also responsible for the structural integrity of the helmet.

The inside structure, containing the Airguard sub-assembly and the Base Ring are enclosed by the hardshell. These two elements can be merged by placing the inside structure into the shell, and then rotating the structure within, until the two parts fit together. (Fig. 93 & Fig. 94) The movement is limited by the surfaces of the goggle retainer holding geometry touching each other. This connection allows a great form-fit, with movement only possible in one side. For better closing properties, and to create a certain threshold of force before opening the structure, friction fit elements were set into place in the front and the back of the helmet.

The full BOM of the Airguard concept can be found in Appendix F.

Development Steps

The hardshell-access was firstly designed with a front hook and a screwed connection in the rear of the hardshell. After testing the available space for placing the hardshell onto the inside-liner, the idea was discarded in favour of an rotational option. Furthermore, the possibility to not using a screw was interesting.

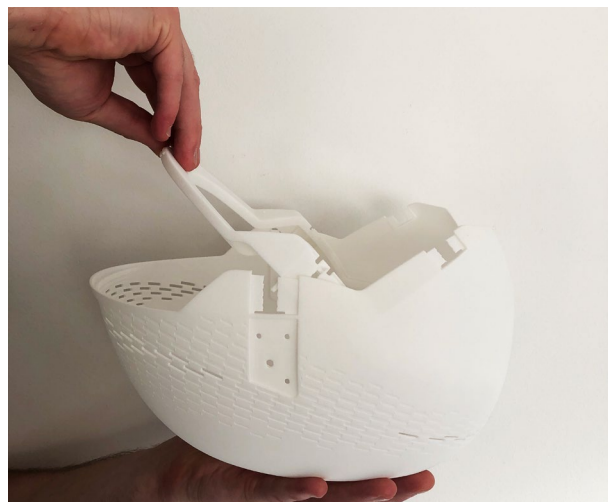
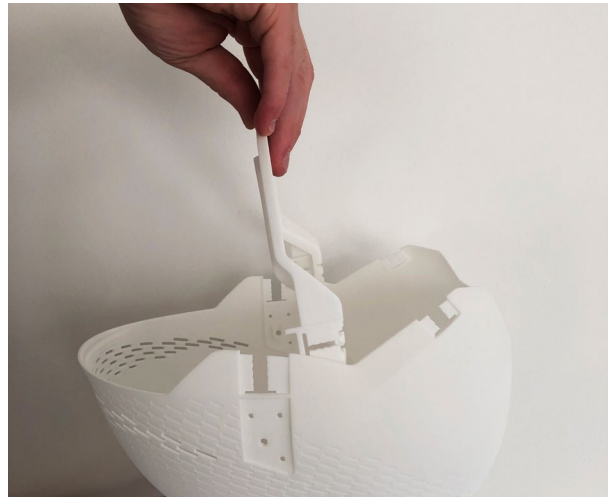

Fig. 92 — Hardshell-Access prototype setup Testing the assembly of hardshell towards Base-Ring.

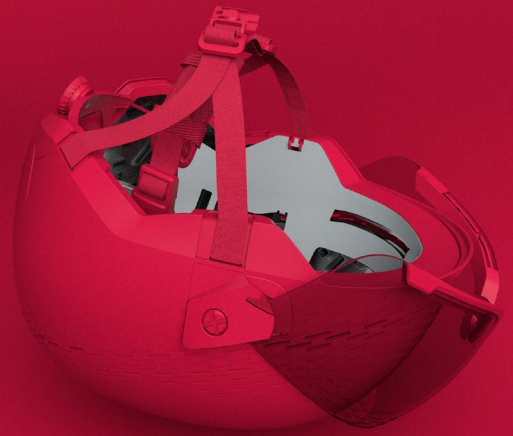

Fig. 93 — Hardshell access sequence

Removing the hardshell and accessing the interior parts in four steps.

Fig. 94 — Hardshell access

The hardshell in the beginning phase of the rotational process

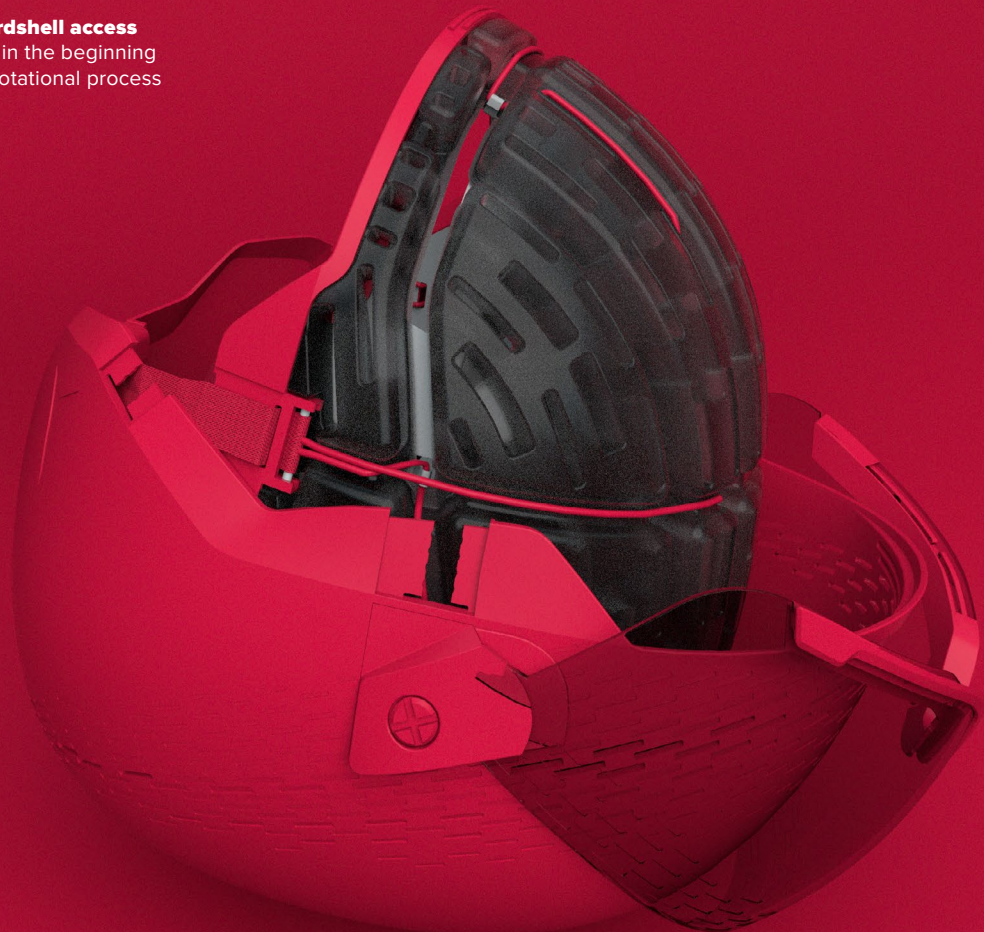



Fig. 95 – Side closing elements and chinstrap as connecting element

Combined closing elements with friction fit increments, guides and a main snap-fit. The chinstrap holds shell and base ring together and creates extra securement of parts.

Sideways closing elements

The secure fit between shell and base ring is provided by side closing elements, located behind the chinstraps in tangent direction to the inside head. Fig. 95 shows these parts outside of their designated positions. The elements have different functions:

- Preventing the helmet's inside from rotating outwards the shell
- Synchronising the positions of shell and base ring
- Creating stable gap-widths between shell and base ring

The position of both items is placed in a way to block the possible rotational movement of the inside of the helmet towards the shell, as seen in Fig. 93. Next, a defined guiding rail centres both parts, the shell and the base ring towards another, the vertical alignment is then defined by toothed resistance-knobs found on the elements, with counterparts in shell and base ring. For even gap-widths, the surfaces of the side elements push the shell towards the base ring.

In order to not loosen the elements once the chinstrap creates tension, a snap-fit element secures the elements towards the base ring. The fixations can be removed by using a lever, e.g. a metal spudger with pointed tip, to open the snap-fit and lift the elements out of their position. The decision for these elements was made because fasteners in this close proximity to the user's head should ideally be tangential, rather than radial. Furthermore, the possibility to locate the elements behind the chinstraps was interesting. Hiding the functionality can already prevent inexperienced users from trying to interact with the elements and tinker with the safety crucial parts of the product. The fact, that a metal spudger is needed to remove these elements provides the second hurdle.

Chinstrap as connecting tool

Another element that is securing the fit between shell and base ring is the chinstrap itself. It is fixated in the base ring, yet then reaching the outside through slots within the shell. When being fastened, and especially in the event of a crash, the chinstrap pulls shell and base ring towards another and is creating a strong bond between these items.

Before the shell can be removed from the other elements, the chinstrap has to be unhooked

from the shell's slots by pulling it through the open guides after the side fixation parts are removed.

The side elements and the chinstrap are pointed in the same direction to create a visually integrated functional fixation compound.



Fig. 96 — Chinstrap as fixation element (functional test)

DESIGN

Removal of chinstrap

After the shell is removed from the inside structure, the first internal safety crucial elements can be accessed. (Fig. 99) The chinstrap pins, holding the chinstraps securely in place, can be reached from the outside, by lifting them with a lever, e.g. a metal spudger. Afterwards, the chinstrap pins can be removed and the full chinstrap can be dismounted by pulling the part downwards.

The chinstrap is secured through a pin, which is held in a pocket through form- & friction-fit, preventing downward movement. The chinstrap passes through the base ring through a slot, can then be equipped with the pin and then fixated in the top pocket.

Fig. 97 shows ideation sketches towards the shown solution. A proposal was also made to cut the front part of the Base-Ring to save weight, yet arguments were made from the client's side to not show the TPU bladder to the front.

Goggle retainer

The goggle retainer, including cord and hook can be removed once the shell is taken off the product. The hook, made from PA66, is connected to the shell through a TPU cord. The cord-outlet is integrated into the backside of the shell and the cord is fixated to the inside of the shell, using form- & friction-fit to hold the end parts of the cord. (Fig. 100 & Fig. 98)

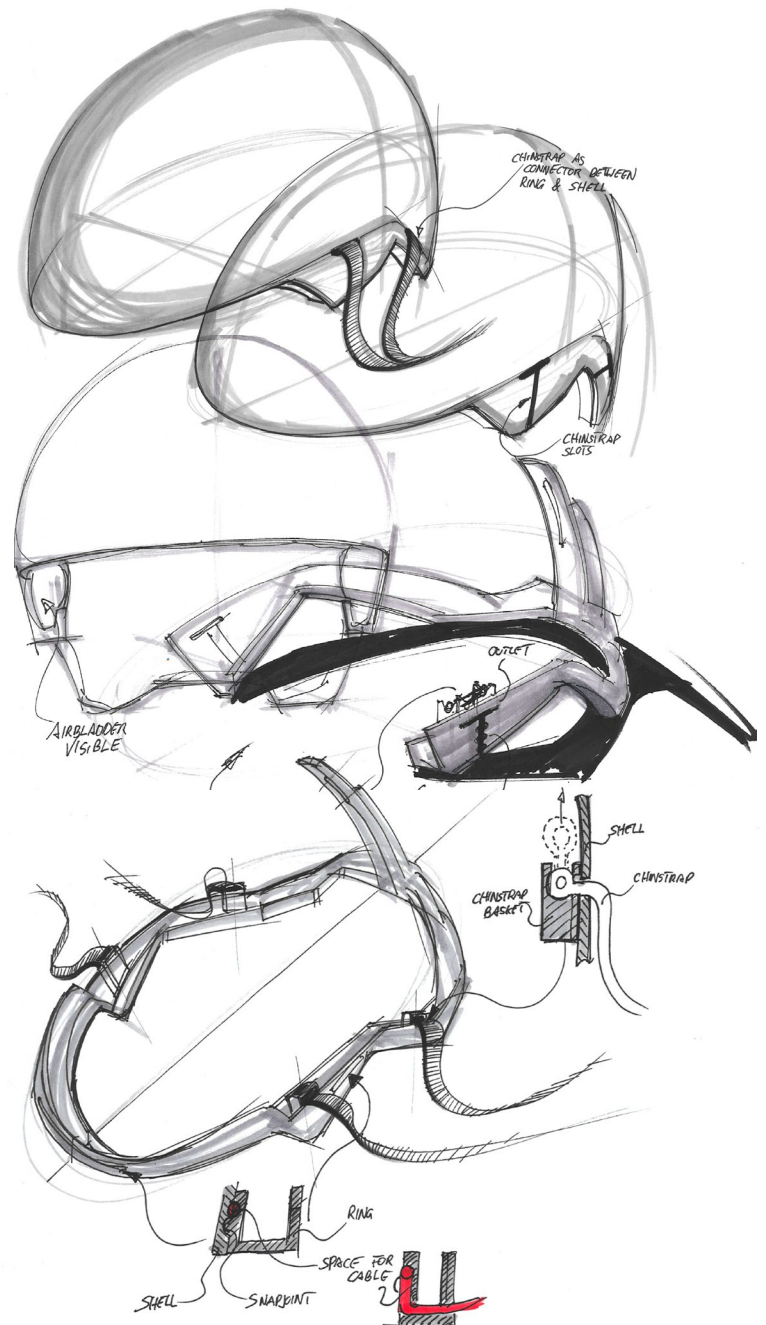

Fig. 97 — Chinstrap integration ideation Concept sketches for exploring the possibilities of integrating the chinstrap into the Base-Ring

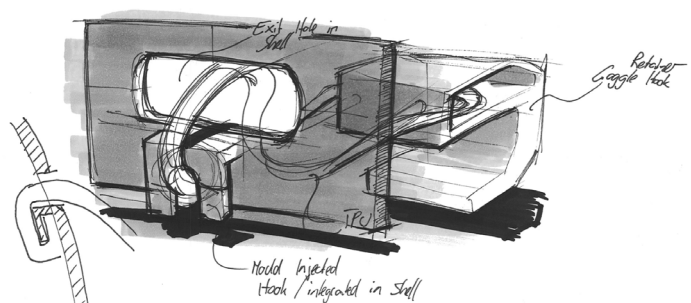

Fig. 98 — Goggle Retainer Fixation ideation sketch Development step towards the Goggle retainer fixation

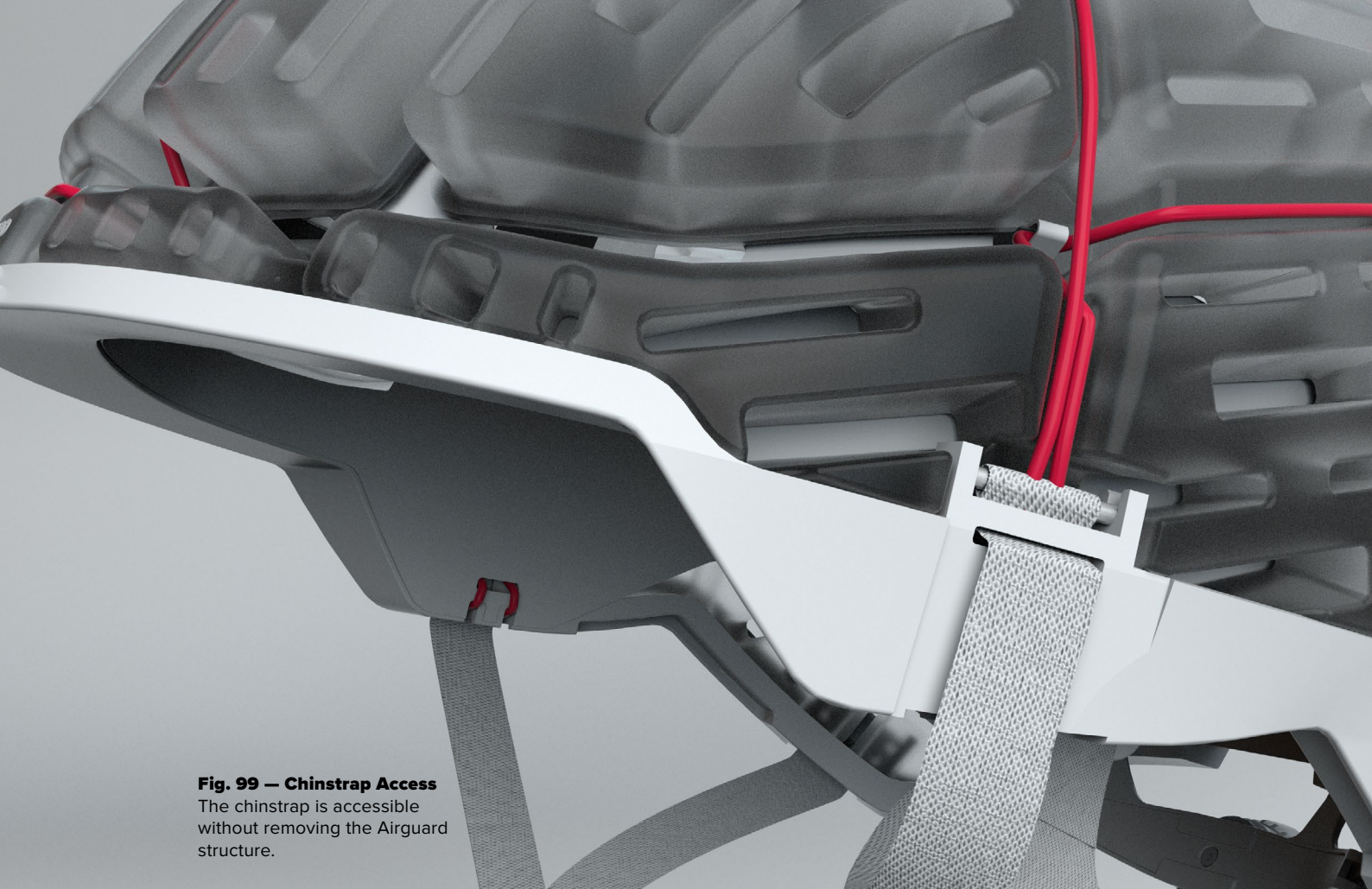

Fig. 99 – Chinstrap Access

The chinstrap is accessible without removing the Airguard structure.

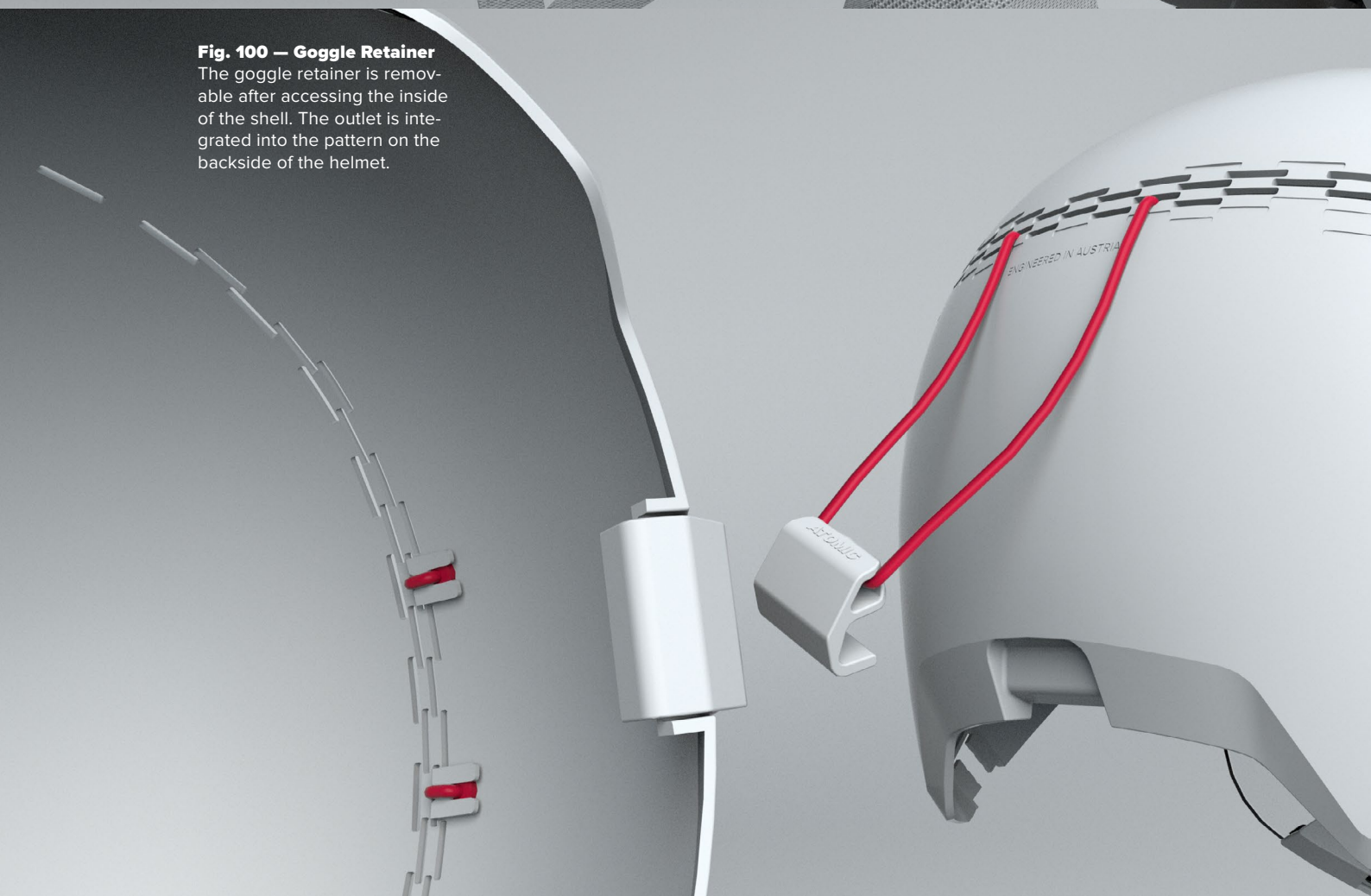

Fig. 100 – Goggle Retainer

The goggle retainer is removable after accessing the inside of the shell. The outlet is integrated into the pattern on the backside of the helmet.

DESIGN

6.2.2 AIRGUARD SUBASSEMBLY

The Airguard system is comprised of two air-bladders with integrated structures of hollow TPU columns. The structure is supported through an inside structural dome, which is connected to the base ring in the rear and the fitting system. The air-bladders are held through TPU cords, which connect them to the base ring. (Fig. 102)

Dual bladder system

The core of the Airguard system is the large outside air-vessel with linear thickness and the smaller vessel with varying, lower thickness. The air-bladders are placed over one another, the outside bladder provides the main shape of the system, also filling the space in-between the ring and the shell. Inside the large air-bladder, the small bladder creates the variable thickness for the human head to fit.

Structural dome

The Airguard system is supported from the inside through the structural dome, holding the air-bladders in place. The thermoformed structural dome, made from Polycarbonate is in place for positioning the air-vessels. Small thermoformed hooks (Fig. 101) are in place to guide the air-bladders in place. On the top of the dome, a channel is situated, guiding the middle part of the small bladder into place, centring the system.

In the rear, following the direction of the channel, the structural dome is connected to the base ring's tongue through a snap-fit joint. (Fig. 102) This holds the dome securely in place, yet gives enough flexibility for the dome to fit to all head forms in the respective helmet size.

The structural dome is a main part of the fitting system. For its integration, the two arms of the fitting system connect to the rear sides of the structural dome through snap-fits on the arms.

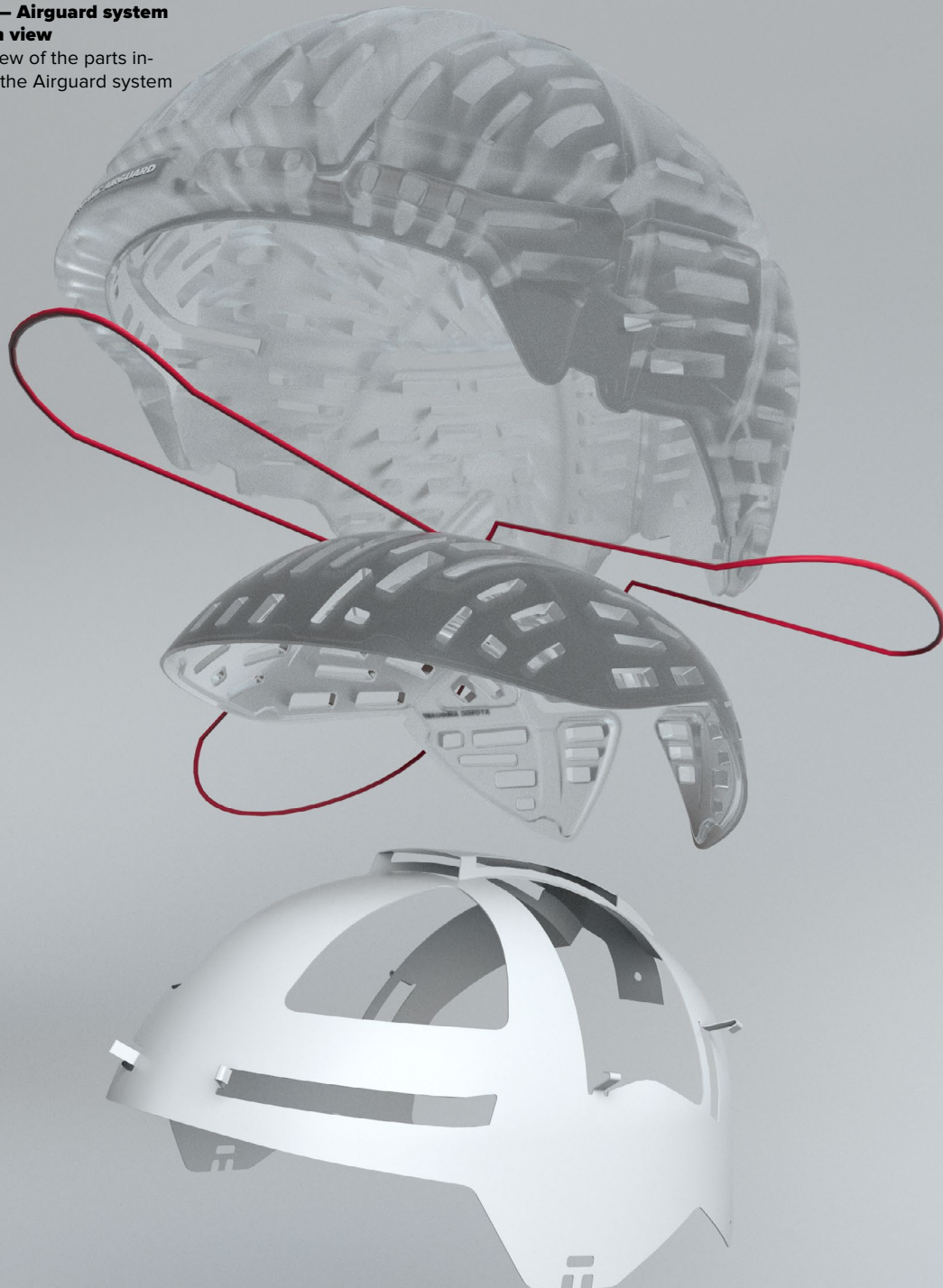

Fig. 101 – Structural dome guiding hook

Small thermoformed elements are in place to hold and guide the TPU cord

**Fig. 102 — Airguard system
explosion view**

An overview of the parts involved in the Airguard system



DESIGN

TPU elastic cord

The small bladder is equipped with a TPU cord, being sandwiched and welded between the inside- and outside sheet of the TPU structure. The TPU-cord is the connecting element between the air-bladders, the structural dome and the base ring. The cord is released through sideways openings in the dome, then follows the air-bladder's sidelines and is guided and fixated through the thermoformed hooks on the dome. (Fig. 105 ff on the following page) The cord then is drawn into the inside of the dome, from which it leaves the dome on the bottom side, connecting to a hook on the bottom of the base ring.

Fig. 103 shows development steps of the fixation between structural dome, air-bladders and base-ring. At first, options were explored, including snap-fit connections, amongst others. During the process, it became apparent to use an elastic TPU-element for fixation to save parts and create a mono-material structure. For better spacial understanding, physical prototypes were used for exploration. (Fig. 104)

Fig. 104 — Structural dome, base-ring and TPU-cord prototype testing

Explorative setup of a development step of the TPU-cord's connection to the structural dome with the bottom hook visible.



Fig. 103 — Airguard fixation and TPU cord development sketches Development steps for the TPU cord as the main connector within the Airguard system including early exploration steps for fixation

RE-DESIGN FOR DISASSEMBLY

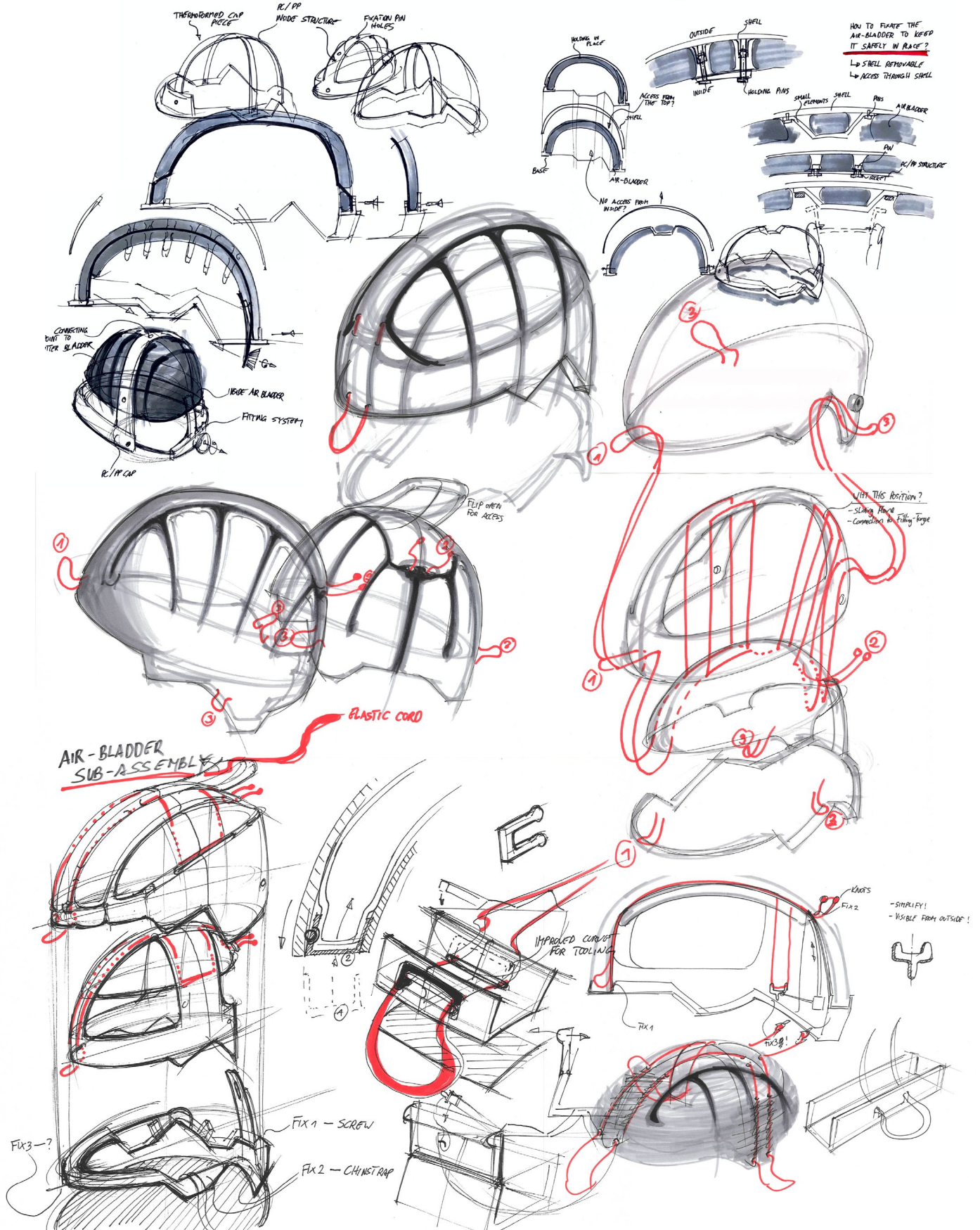

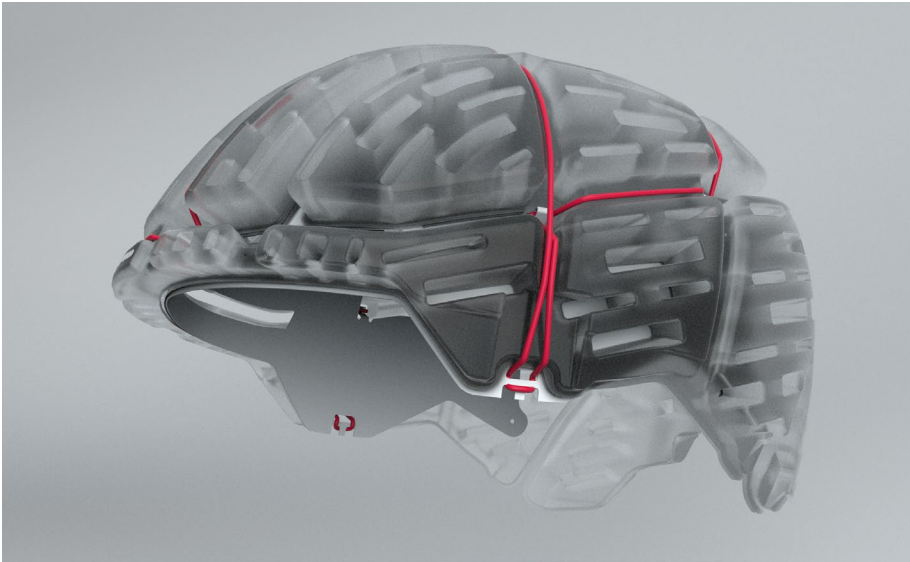

Fig. 105 — Airguard Subassembly
The Airguard system is removable and re-attachable without disassembling further

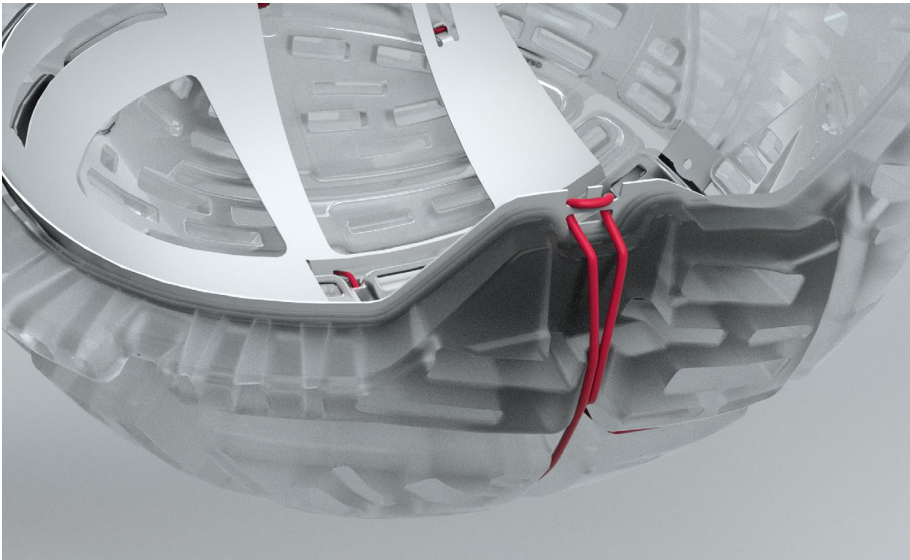

Fig. 106 — Cord in idle state
The TPU cord is placed on a bottom hook, ready for assembly

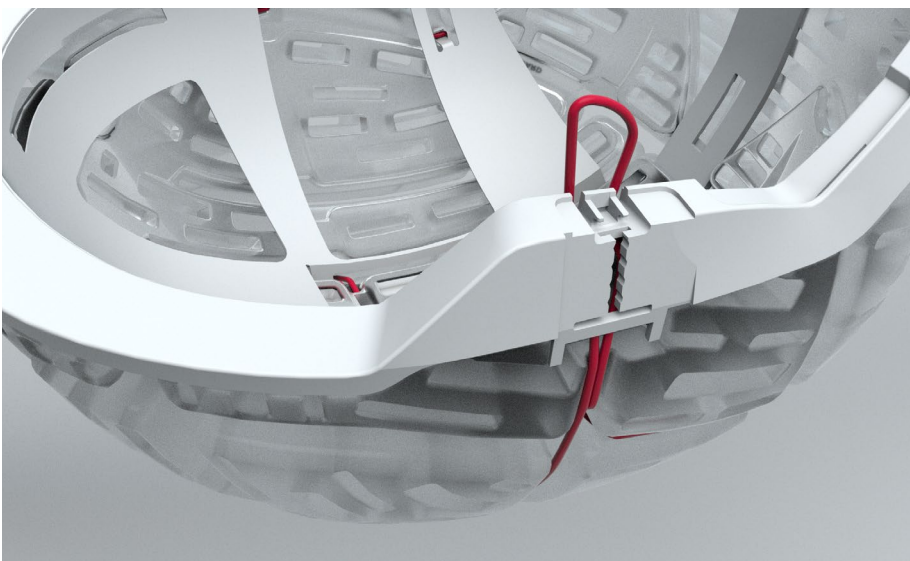

Fig. 107 — Cord placed on base ring hook
The connection to the base ring is established through placing the cord onto the bottom hook of the base ring

Airguard Subassembly

The two airbladders and the structural dome together form the Airguard subassembly. This compound is held together by the TPU cord and is removable and re-attachable in one piece, without further disassembly. (Fig. 105)

In pre-assembly state, the TPU cord can be fixated onto a hook on the structural dome's bottom. (Fig. 106) When being attached to the base ring, the cord is replaced from the hook on the structural dome's side and is placed on the hook in the base ring. (Fig. 107) This connection is then closed off through the sideways closing elements. (Fig. 108)

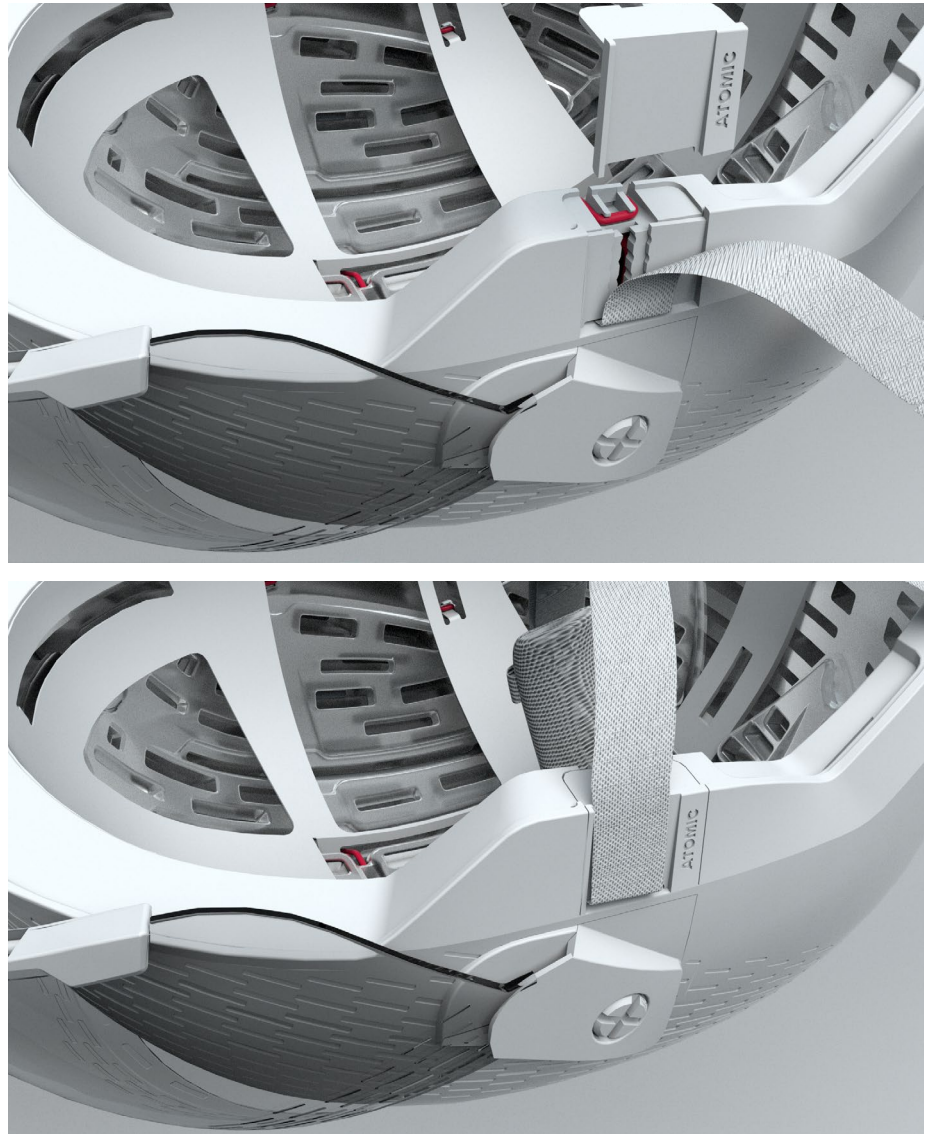

Fig. 108 — Sideways closing element

The side-fixation elements close off and secure the connection between base ring and TPU cord

DESIGN

6.2.3 FUNCTIONAL BASE

The main foundation for the Airguard subassembly, the fitting system, chinstraps, earpad-hooks and finally the hardshell, is the 'base ring'. (Fig. 110) This structural base is designed as a 360° ring, following the inside of the Shell. The ring is made as a U-profile, which holds the big bladder in place, once it is inserted.

Fitting system connection

In the rear, the base ring-tongue is in place. The tongue accommodates a guide for holding the fixation system. It allows the fixation system to be adjusted within three increments, with resistance points as thresholds to overcome and to set the three fitting levels. At the top of the tongue, a snap-fit joint for the structural dome is available.

Airguard connection

Next to the snap-fit on the top of the tongue, the Airguard subassembly is connected to the base ring through TPU cords. For these TPU cords, two hooks are in place on the bottom of the base ring.

Earpad hooks

The earpad hooks are connected to the base unit through slots in the middle of the item's sides. When these parts are connected, the whole earpad hook is located flush within the structure.

Closing elements

In the front- and back-third of the part's sides, the connecting points for closing the shell are located. These are equipped with toothed guides, a defined slot for the chinstrap to move through, and the bearing for the chinstrap pins to rest on. Furthermore, to the bottom of the element, the counterparts for the closing element's snap-connectors are placed.

These closing elements, when put in place, are resting flush within fitting pockets in the base ring. To support base and ring with holding their position, friction-fit elements are put in place in the front and the back of the item.

Manufacturability

The base ring is the main connecting item, replacing many in-mold assembly fixation parts. To decrease the complexity, focus was put on limiting the number of directions for tooling and demolding later.

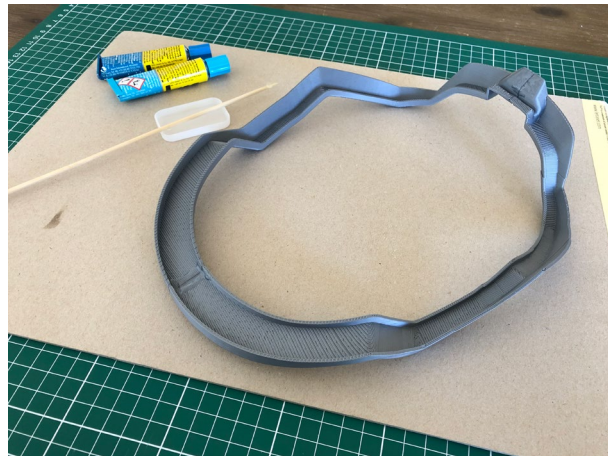

Fig. 109 — Prototyping and testing stages of the base-ring Assumptions on fixations were tested quickly within rough prototypes

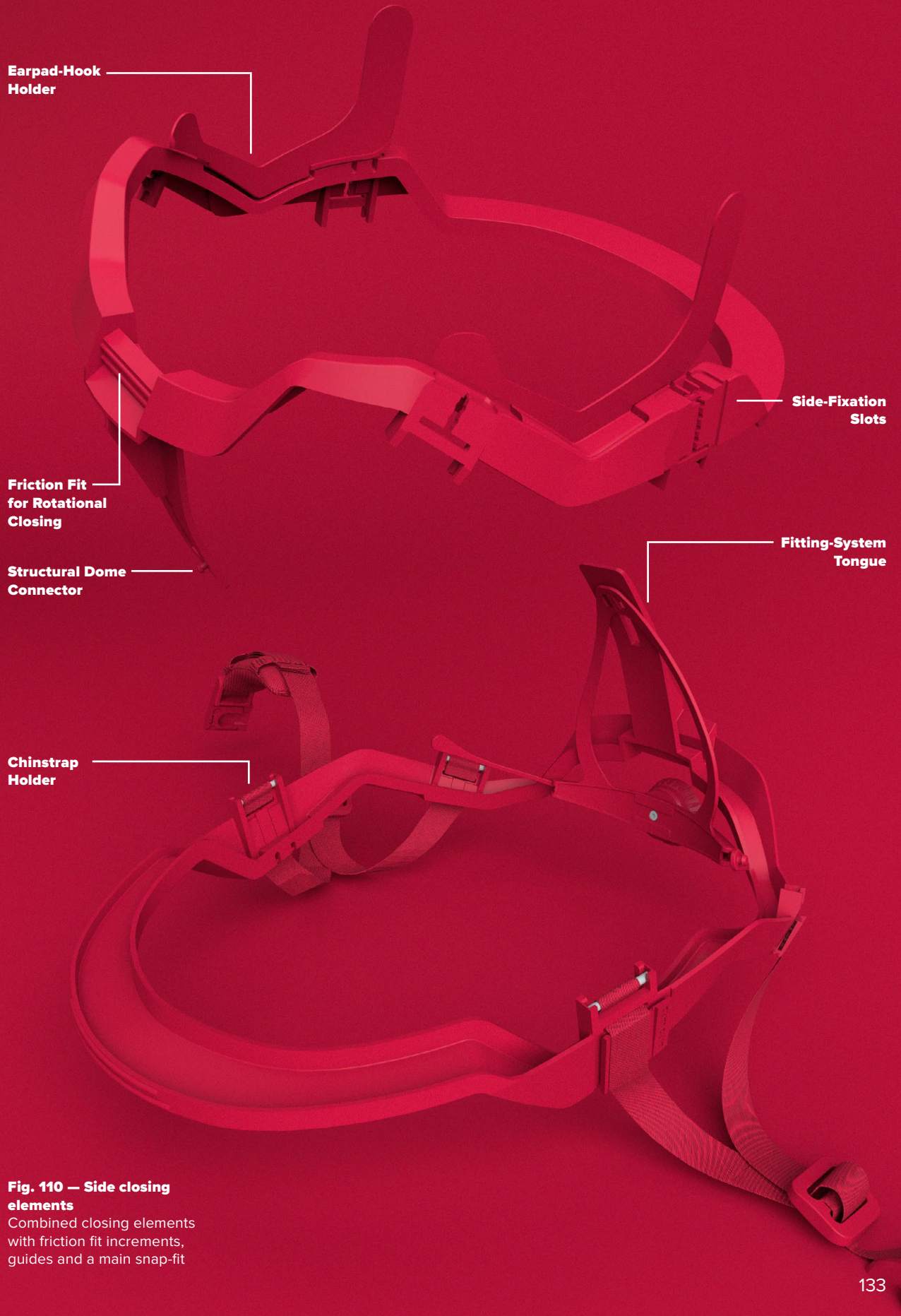
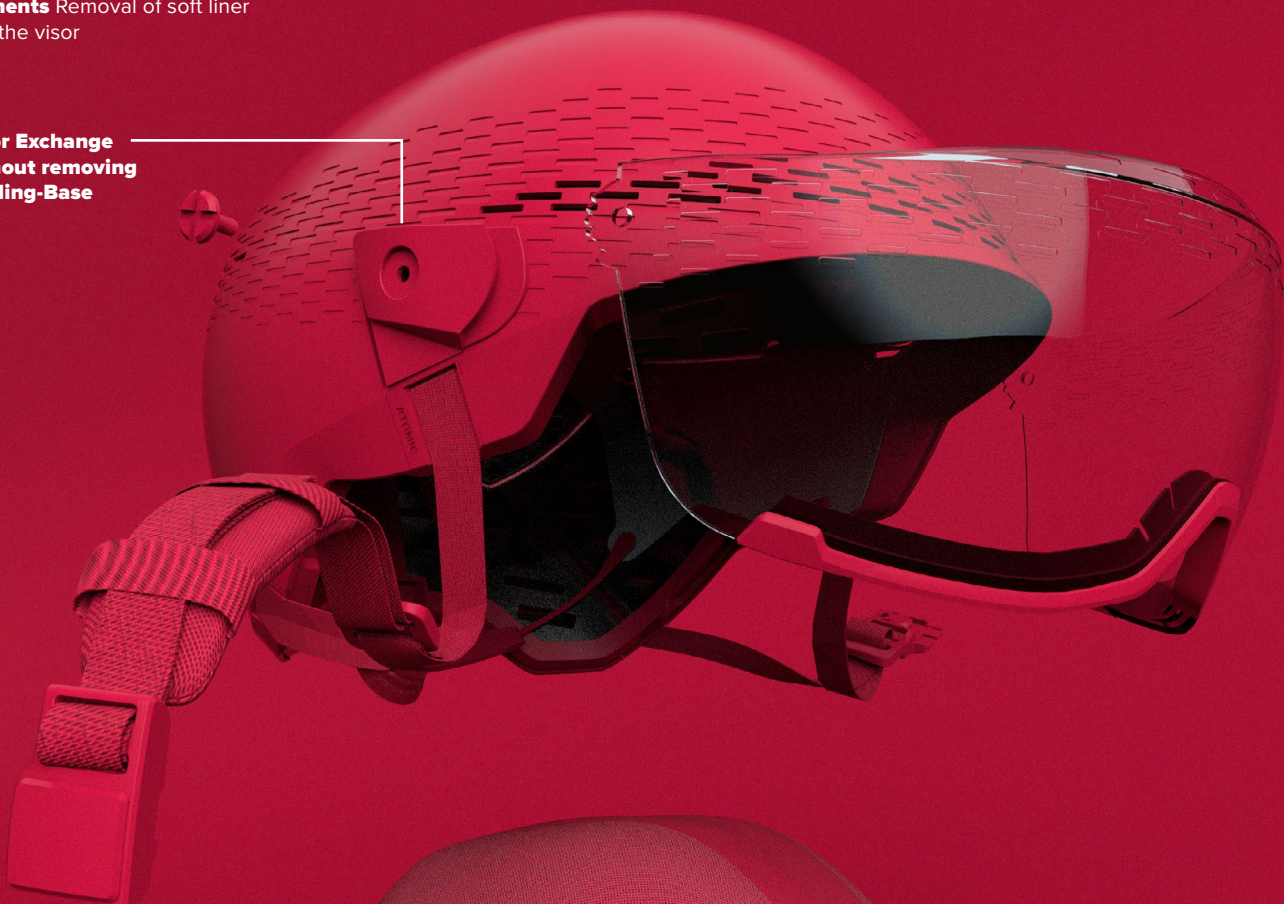

Fig. 110 — Side closing elements
Combined closing elements with friction fit increments, guides and a main snap-fit

Fig. 111 — User access elements
Removal of soft liner and the visor

Visor Exchange without removing Holding-Base



Earpad-Hook

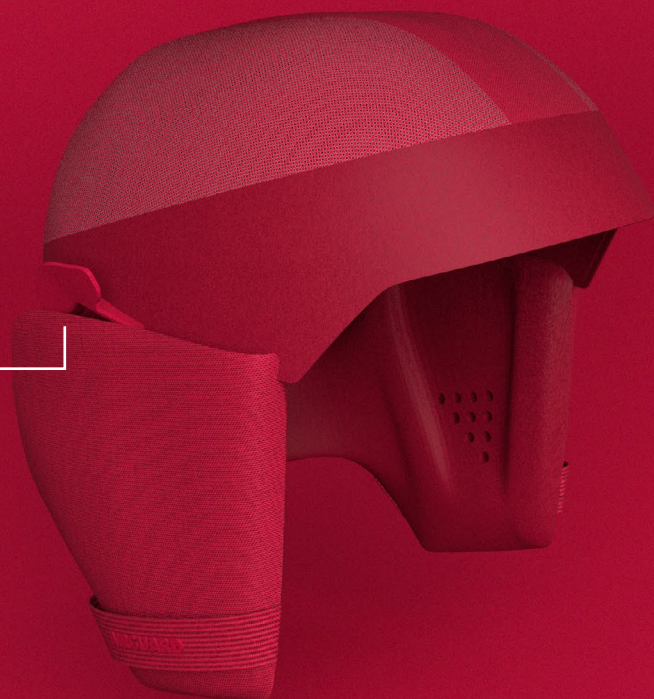

6.3 MAINTAINING PRODUCT (PART) VALUE

6.3.1 USER ACCESS

A focus within the re-design was, to collect all safety crucial product parts behind the protection of the hardshell, but still allow users to access non safety relevant elements linked to crucial value perception. This includes the soft liner and the helmet's visor. (Fig. 111) The soft liner and the visor are parts associated with being in constant contact with the user and being exposed to outside influences, leaving scratches or other signs of wear. Exchanging or replacing these parts is very important to keep the perceived value of the products up, and save the impact of fully replacing the helmet once these signs of deterioration appear.

For making this worthwhile, the manufacturer has to offer replacement parts of similar quality, parts with updated aesthetics or parts with updated technologies, once these are available (e.g. better active fabrics in soft liners, better visual performance in visors).

Removal of the Soft Liner

The soft liner is connected to the structural part of the helmet through hooks made from PA66. The hooks are held in place within the soft liner through form-fit. The parts are slid into the ear-pad section, with the connecting parts then leaving the textile through designated slots (in the baseline model, this was facilitated through sewing these parts to the soft liner — therefore only removable in a destructive manner).

After adding the hooks to the soft-liner, the textile piece can be installed to the helmet by hooking the elements on one side, and then rotating the other side into the slots. Through that, form- & friction-fit is in place, keeping the soft-liner conveniently in place. The liner can then also only be removed after following this exact movement. (Fig. 112)

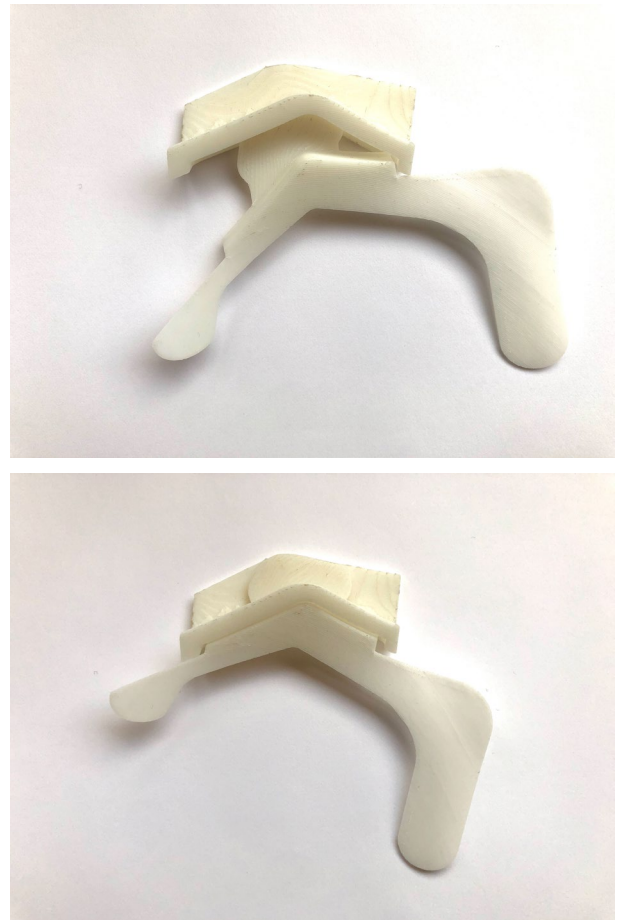

Fig. 112 — Earpad-hook mechanism testing

DESIGN

Visor Exchange

The visor is removable by the user. The visor lens is held in place by two elements, mounted on either side of the shell, within a mounting pocket. The full system is fixated through M4 screws, that can be handled by a Philips screwdriver in size 3 aiming at being removable with standard tools. The screws are countered by nuts located on the inside of the shell, held in place by form- & friction-fit. (Fig. 114)

The visor fixation elements (PA66) are made of two parts, one base- and one closing-element. (Fig. 113) The base element is equipped with two positioning pins towards the shell, and one pin towards the visor, being its pivot point. Furthermore, a surface for the visor to rest on, and two teeth are in place, giving the user increments on which the visor can be rested when opened.

After the base element is in place, the visor can be put onto it, by using the pivoting element to position the lens. Afterwards, the closing element comes into place. It fits around the base-element through form-fit. One additional pin is positioning the part to the base-element and the shell, one pin closes the connection to the pivoting point. The added screw then presses the two holding elements and the visor's lens towards the shell, providing a secure fixation.

When the visor needs to be replaced, the screws can just be loosened, the holding elements opened slightly, and the new visor lens can be inserted. Fully removing the three parts is not necessary. Upon recycling, the visor can be removed and the holding elements can be removed together, creating more convenience.

Fig. 113 – Visor fixation elements Base and cover elements, including screws and the inside nut. The nut is already placed inside the shell, the outside elements can be replaced by the user.

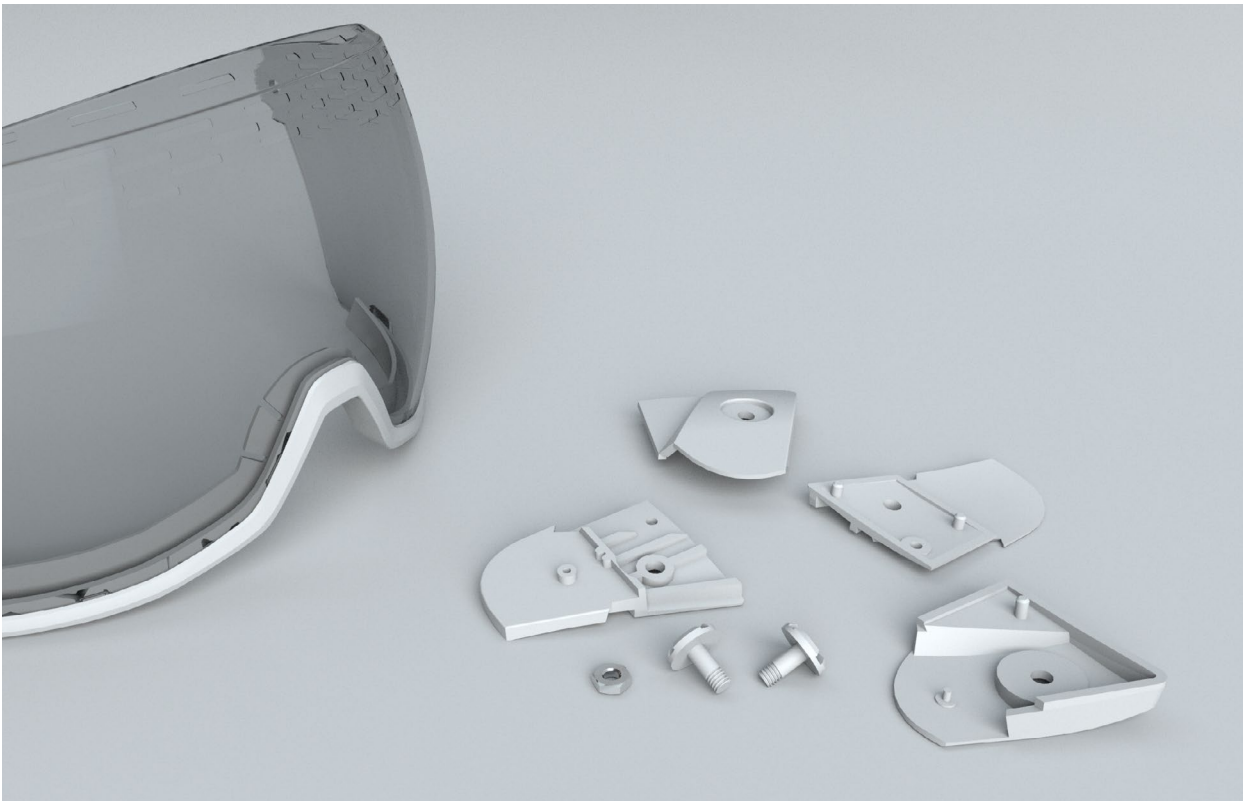

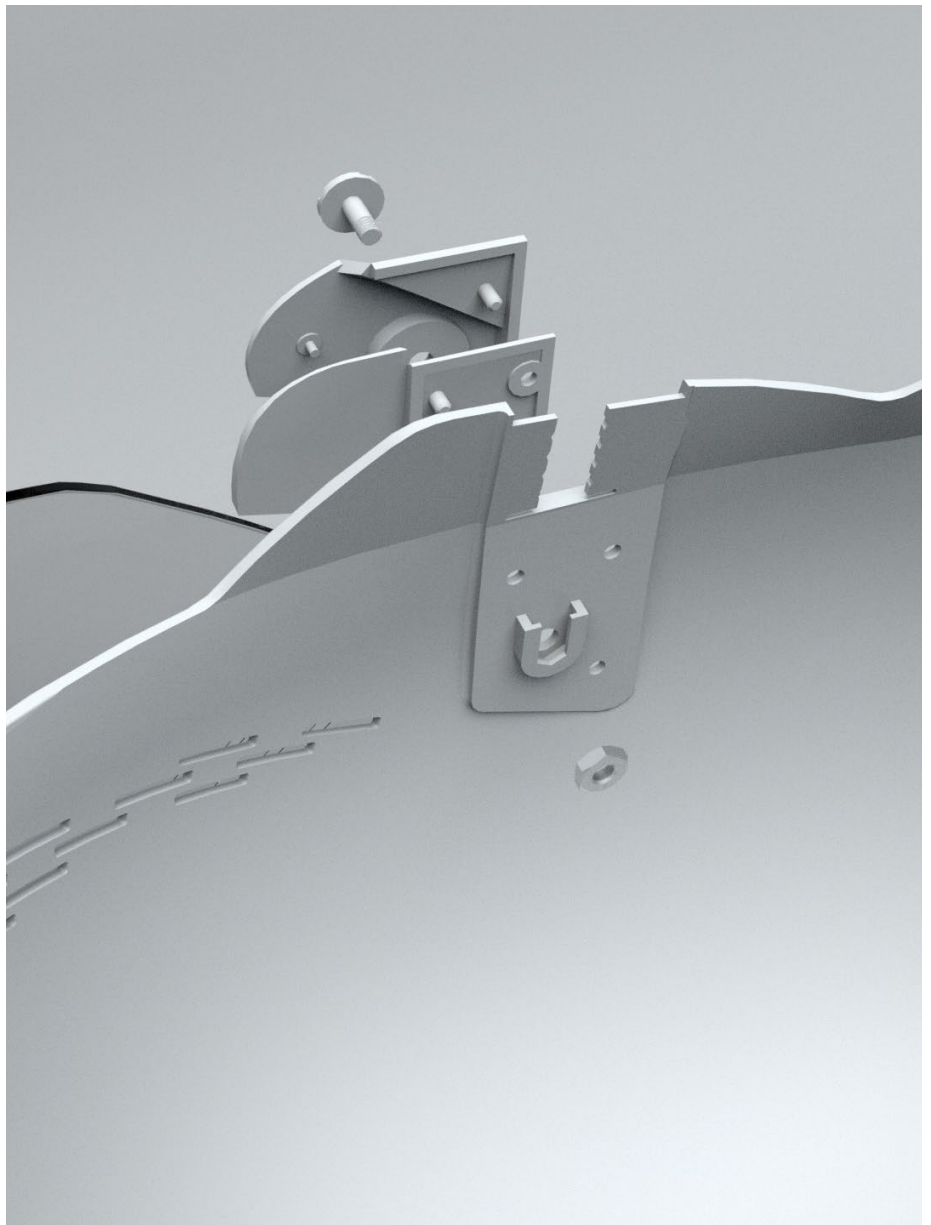

Fig. 114 — Screw counterpart on the shell's inside
Schematic visualisation of the fixation array for the visor.

DESIGN

6.3.2 RECYCLING

The basic requirement for the Circular Economy is, that used parts and materials can go back into the circles by being recycled. The re-designed product architecture enables the separation of parts of different materiality for suitable recycling. Furthermore, the number of materials was reduced from 15 in the baseline model to eight different materials in the re-designed model. (Tab. 5)

Material	Weight [g]	Proportion of Weight [%]
TPU (Thermoplastic PU)	260,9	34,1%
ABS	210	27,4%
PC	97,5	12,7%
PA66 (Nylon)	86,8	11,3%
Dacron (Polyester fibers)	78	20,2%
Polyethylene Foam	23,1	3,0%
Stainless Steel	9,1	1,2%
POM (Polyoxymethylene)	0,5	0,1%

Tab. 5 – Materials Atomic Airguard

Material Used

The Airguard's main material is TPU. It is used for the air-bladders and the goggle retainer cord. ABS is used for the hardshell, PC for the visor and the structural dome, supporting the air-bladders. Nylon (PA66) is used for mechanical parts, where durability is needed, like the base ring, most parts of the fitting system (except a gear made from POM) and the closing elements on the side. Dacron (Polyester) is used for textile parts with PE-foam for paddings. Lastly, stainless steel is the only metal used. Elements like screws and nuts are made from this material.

Full Recycling and Recycling of Main Parts

Ideally, the full product would be recycled, with all single parts following a collection process. For further discussion, this scenario is referred to as 'Full Recycling' or 'Recycling Scenario 2'. However, also the recycling of only the main parts of the product would regain the largest part of impact. While this is a trade-off scenario, it should stand as a proposal for a feasible recycling scenario, also for early movements into the recycling-direction. shows the parts with the largest proportional impact highlighted within the full product assembly, including proportions of their weight, CO₂

impact, energy consumption and economic value. (A detailed analysis of the part's impact, compared to the benchmark product follows in chapter 6.5.4, starting on page 153) These elements would be the shell, the visor, the Airguard-bladders, the structural dome, the base ring and the textile liner. The recycling of these elements is referred to as 'Main-Recycling' or 'Recycling Scenario 1'.

6.3.3 REMANUFACTURING

In order to regain more of the product's impact, the EoU scenario of this re-designed ski-helmet should include remanufacturing of specific (durable) parts. Remanufacturing, within this case, would be a step to use the full lifecycle of specific parts that are not subject to fast deterioration. Through that, cost can be saved and environmental impact can be avoided. Fig. 117 shows parts that are considered for this scenario.

Airguard System

The first part included in the remanufacturing scenario is the Airguard's dual air-bladder system. TPU has high elasticity and therefore is able to re-take its original form, even after large numbers of impacts. The brand Schutt places this material in a comparable system within football-helmets and makes use of the absence of plastic deformation, or 'material break-in'. TPU is impervious to sweat, molds and other environmental influences. It can be easily reconditioned and a part of Schutt's business is providing reconditioning of their products, including the TPU impact cushions. This stands as a case-study for remanufacturing the TPU-parts in the Airguard system. Another part within the Airguard system is the PC-structural dome. This part can also be included in the remanufacturing case.

Parts not Involved in Impact-Management

Next to the TPU air-bladders and the PC-dome, parts like the base ring, the fitting system without its toggle and the earpad-hooks can be part of the remanufacturing process. These are parts not involved in impact-management and also not outside parts that are linked to visible deterioration and crucial value perception. Items in this category are made from PA66 and therefore strong, with decent flexibility and also durable. These parts, and the parts within the Airguard system are included in 'Remanufacturing Scenario 1', or 'Remanufacturing of Main-Inside Parts'.

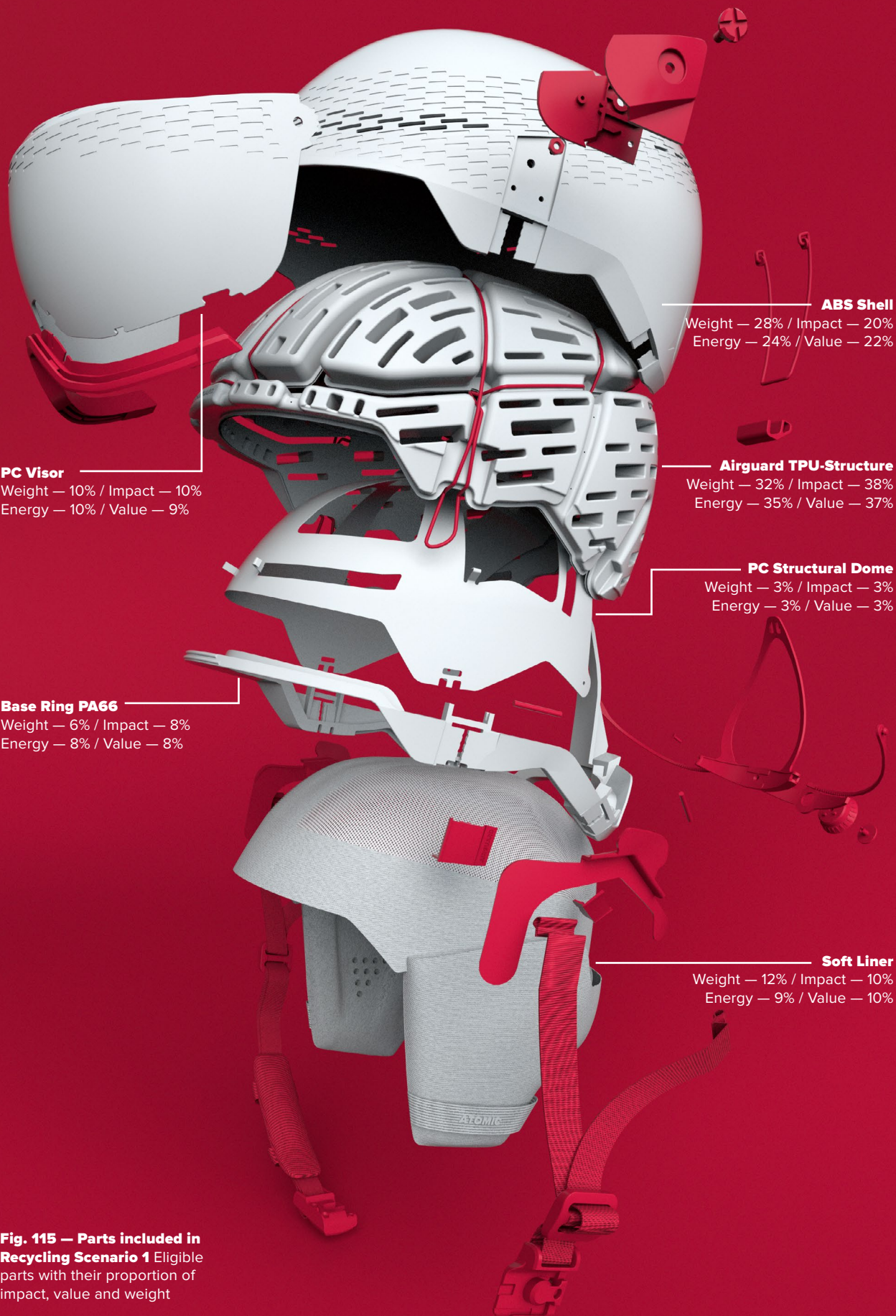

Fig. 115 — Parts included in Recycling Scenario 1 Eligible parts with their proportion of impact, value and weight

DESIGN

Remanufacturing of the Shell

An additional scenario for remanufacturing includes all before mentioned parts, plus the shell. The shell is a large part with a large portion of weight, impact and value. This part could be cleaned and rebuilt into an as-new product. However, the shell is a part that can be damaged in impacts and loses its functionality. Also, it can deteriorate visually over time, with a decrease in its perceived value. In order to bringing this system into reality, there must be a process of investigating part-health, and processes of reconditioning the part in a way so it becomes acceptable as an 'as-new' or 'used, but safe' product. This scenario is referred to as 'Remanufacturing Scenario 2', or 'Remanufacturing of Main-Parts'.

Product Health Investigation

Parts like the TPU system or the base ring are durable and can withstand multiple impacts. However, knowing about the actual occurrence of critical impacts is crucial for the remanufacturing process. Products that are being analysed as non-impacted can undergo different assessments than parts within impacted products.

In chapter 2.5, different impact assessment devices were shown. However, these are either not suitable for helmets in their dimension, too expensive or add environmental impact to the product. Therefore, the product health assessment should make use of a simpler, analogue technology. The defined holes within the impact-management system should be equipped with impact indicators. The sensors could be designed as indication-stickers, placed on the outside of the holes. They could have a mesh-like or perforated-surface, with openings that allow air to pass freely until a defined threshold. When this threshold is being overcome, the perforation could allow the sticker to rip. Upon examination, these indicators can be visually analysed. Shown damages would point towards an impact above a certain threshold and remanufacturing-parts could be either subject to more thorough examination or be excluded from the process entirely.

An inspiration for low-tech sensor solutions like this can be found in high-tech products like Apple MacBooks. On the inside of these devices, analogue sensors are used to indicate possible water-damages. When certain thresholds of humidity are passed, these indicators show a red colour, leading to the liability being void. (Fig. 116)

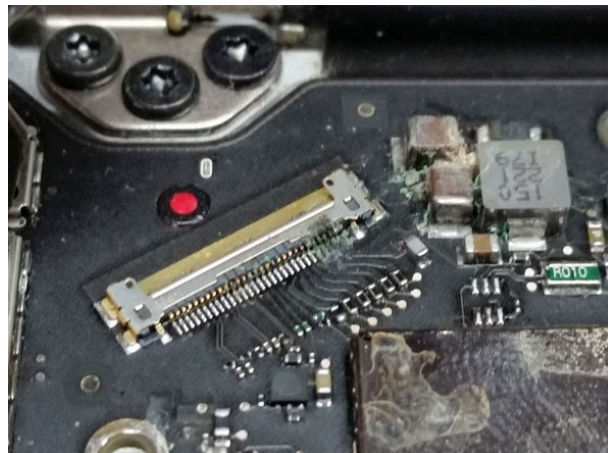

Fig. 116 — Humidity Sensors within MacBook Pro (Vale, 2017)

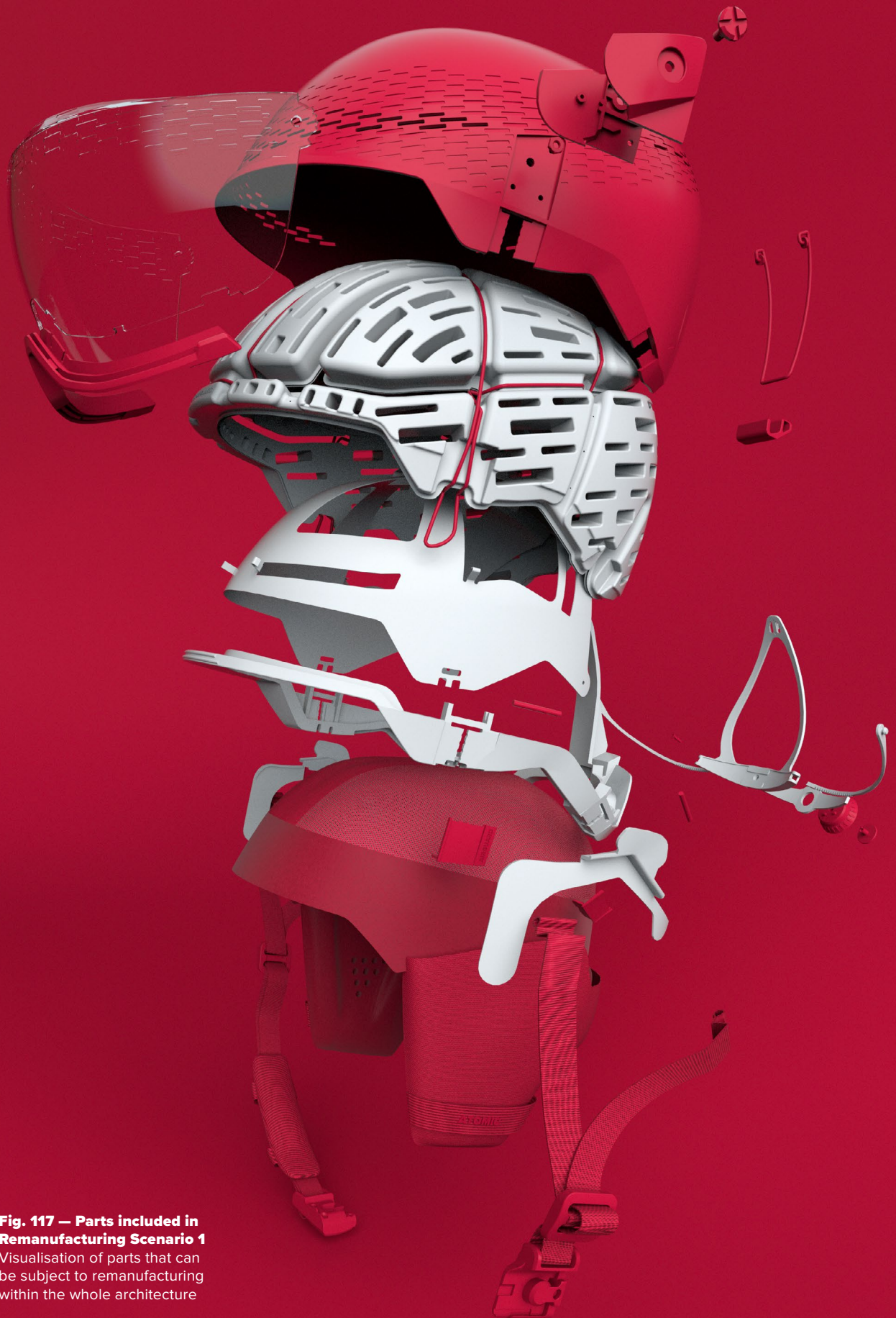

Fig. 117 — Parts included in Remanufacturing Scenario 1
Visualisation of parts that can be subject to remanufacturing within the whole architecture

DESIGN



Product in Use

Up-Trade Collection Structure

Collection Process

Part Separation

Part-Health Analysis

Closing the Loop

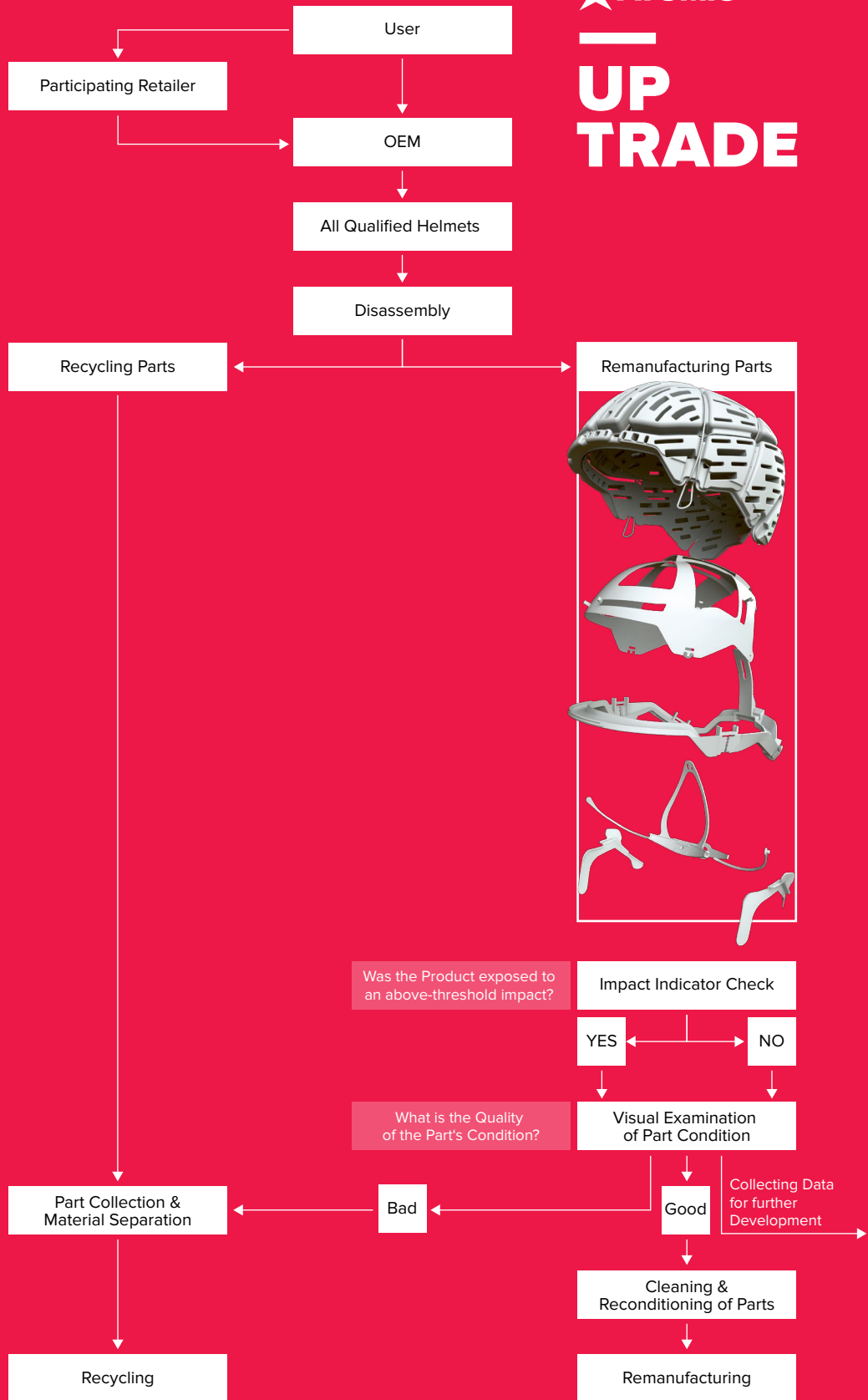

6.3.4 TAKE-BACK SYSTEM

For the proposed services of controlled recycling and OEM facilitated remanufacturing, a controlled take-back system should be set in place. This take-back system — the Atomic Up-trade Service — can include direct take-backs from the OEM's side and also collaborations with selected and trusted retail-stores. (Fig. 118) Eligible Products (helmets with full disassemblability) can be returned through the postal-service, directly to the manufacturer. Additionally — as this should be more convenient for many users — the process can be facilitated through an Atomic-affiliated retailer. As users walk into shops to buy a new helmet, the retailer then would collect the customer's used products and send them back to the manufacturer. This would be a feasible solution, as these stores already receive shipments from the manufacturer and can use these logistics to retrieve used helmets to the OEM.

After declaring the return of a used product, or returning it at a certified dealership, a new helmet of the same brand can be bought at a discount price. Companies like Sonos offer a similar system, with eligible speaker-products being taken back by the company and offering discounts of 30% on the retail price of a new product. (Sonos, 2021) An example from within the sports industry is given by Woom, an Austrian manufacturer of children's bicycles. Woom offers a take-back system with up to 40% money-back once an old bike is exchanged into a new model of a larger size. Within their 'up-Cycle' programme, they connect this service to a membership, sold at €47 and through that simulate the 'growing' of the bicycles, analogue to the children's growth. (woom, 2021)

User Loyalty

Customer Retention is tremendously important for companies like Atomic. Many different companies offer comparable products, with the user's decisions for purchase often made directly at the shelf. With building an Atomic-owned take-back service, connected to an incentive to upgrade to a newer Atomic model, customer loyalty and retention could be improved. Ideally, users would gain discounted access to the newest models available, which could lead to loyal customers and users.

Fig. 118 — Atomic Up-Trade Schematic

Description of the removal of soft liner and the visor

6.4 INCREASING PRODUCT VALUE

Recycling and remanufacturing are solutions to regain value after the product's end of use or end of life. Next to these, another focus for more sustainability within ski-helmets should be keeping the good's value intact and even increasing it over its time in use.

Currently, ski-helmets are sold as fixed configurations within a brand's product portfolio. At this point, Atomic offers four different models of helmets in 21 different configurations — only in their male-segment offered on their website. 82 models are available, when including all offered colour-ways. This includes helmets with and without visor and also helmets with other functions, like headlamp-holders and fixations for chin-guards for ski-racers. Currently, the replacement of visors is possible but not upgrading to a visor from a non-visor helmet (or vice versa). In this case, a new helmet has to be bought. Chin-guards are sold as accessory for specific models.

Upgrading ski-helmets

The concept developed within this thesis includes the possible upgrading of ski-helmets through a modular mounting base, located in the shell, in the position of the visor fixation. This base can hold visors, which are held in place through screws. It can also close this slot, when goggles are used instead of a visor. In this case, a cover can be held in place with a snap-fit solution. It can also hold headlamp fixations and let a chin-guard be screwed to the system. The mounting plate for the chinguard can include an angular adjustment system for fitting to the user's needs.

These solutions cover the current product segment, offered by Atomic. It can also include different functionalities, e.g. mounting points for helmet-cameras, or customisation options, e.g. for children's helmets.

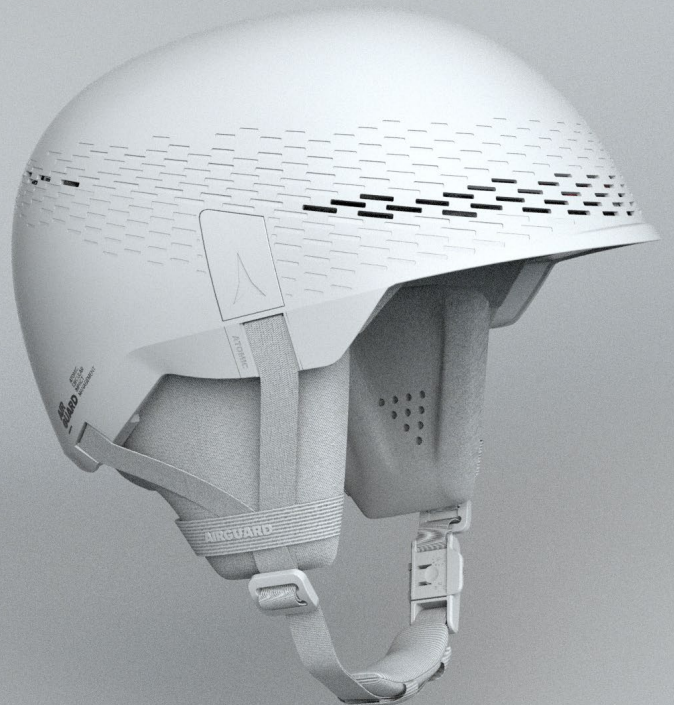
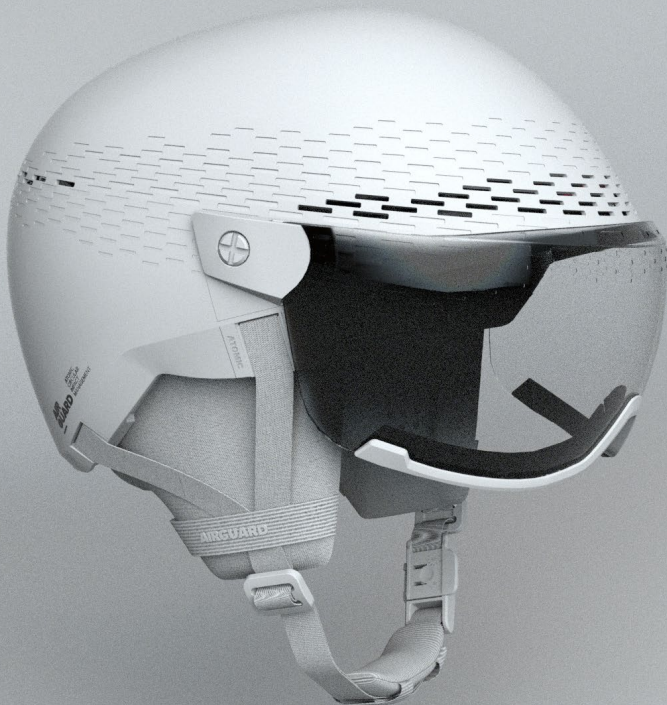

INCREASING PRODUCT VALUE

Fig. 119 — Product Eco-System within one model

The modular mounting base enables the development of a product-add on portfolio, offering aftermarket additions to an existing product.

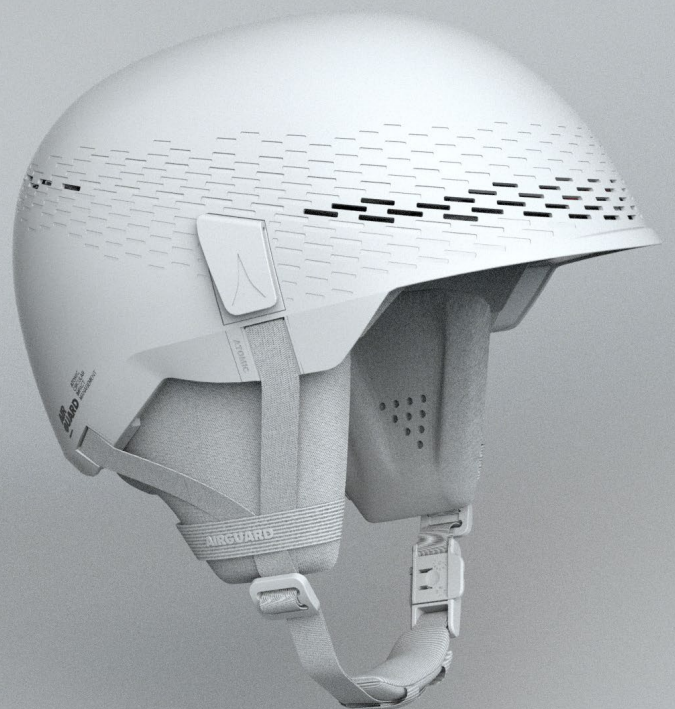

6.5 RE-DESIGN EVALUATION

6.5.1 HOTSPOT ANALYSIS

Number of Different Parts

Firstly, the re-designed Atomic helmet — the Atomic Airguard — shows less parts than any other helmet that was subject to analysis. (Fig. 120) The Atomic Airguard is made from 32 different parts, while the analysed helmet with the lowest number was the Atomic Savor AMID, with 34 parts (no visor). An improvement was especially made to the baseline model Atomic Savor GT AMID Visor, with 47 different parts.

Disassembly Steps and Tasks

The comparison of needed steps and tasks for full disassembly provides an indication of improvement of disassemblability. However, the evaluation is made compared to ‘full-disassembly’ of products that were not able to fully take apart, because of in-mold assemblies. However, a comparison is still valid. Compared to the assessed products, and the baseline product, the Atomic Airguard concept shows a decrease in the number of steps needed for full disassembly. (Fig. 121) The concept demands 36 steps for full disassembly. The baseline model needed 53.

When considering all undergone actions and their repetition needed to dismount similar parts, the concept accounts for 70 different tasks. (Fig. 122) Compared to the baseline model (84), this is an improvement. However, other models, like the Head Rachel model (66) or the POC Fornix SPIN model (64) settled at lower numbers. Again, the disclaimer has to be made, that this left out many parts that couldn’t be removed at all.

Tools and Fasteners

An important finding in the analysed products was the number of different tools needed for disassembly. This included levers, screwdrivers, but also long nose pliers, side cutters, and knives.

The concept was re-designed to use less tools. For full disassembly, three tools are needed: A Philips screwdriver (PH3), a Torx screwdriver (T6) and a metal spudger. Compared to the baseline model, this is an improvement, as this model needs seven different tools. Only the model Head Rachel uses the same number of tools. (Fig. 123)

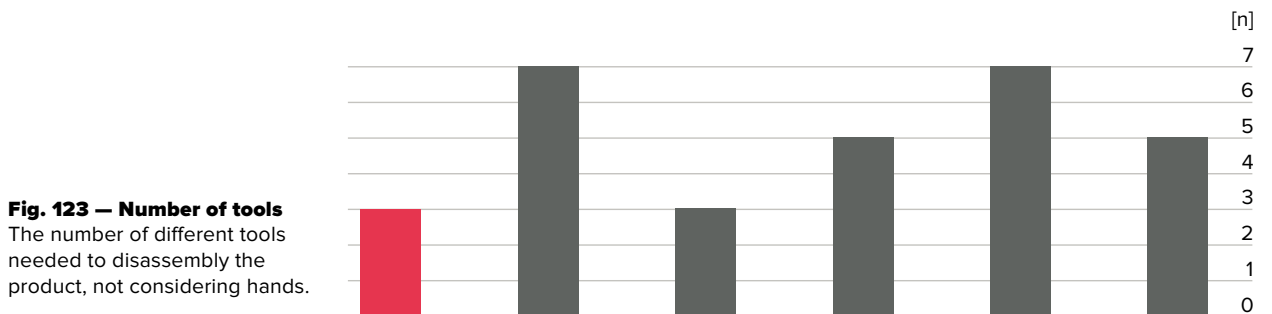
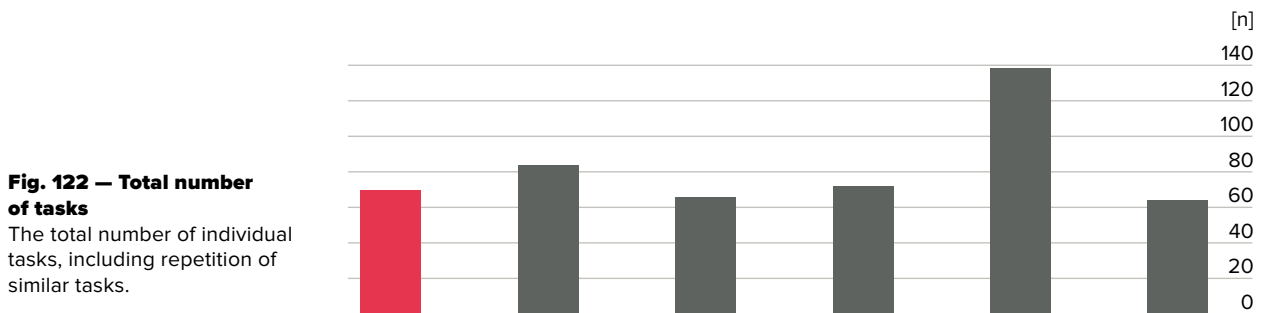
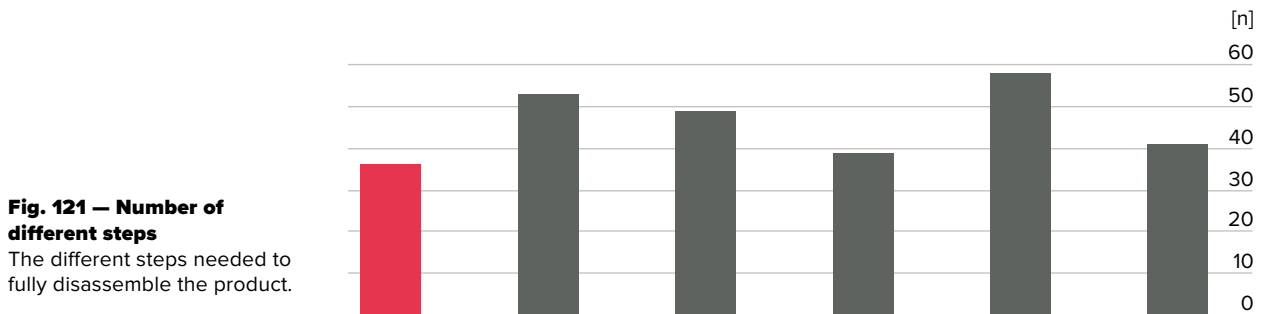
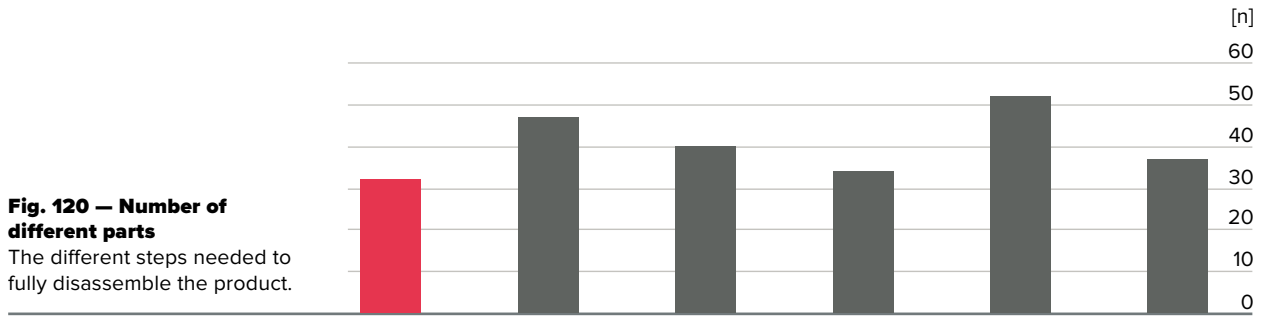

Brand	Atomic	Atomic	Head	Atomic	Smith	POC
Model	Airguard	Savor GT AMID Visor	Rachel	Savor AMID	Vantage MIPS	Fornix SPIN

DESIGN

Fig. 124 — Tasks needed to remove key parts
Number of tasks for the removal of important parts and subassemblies

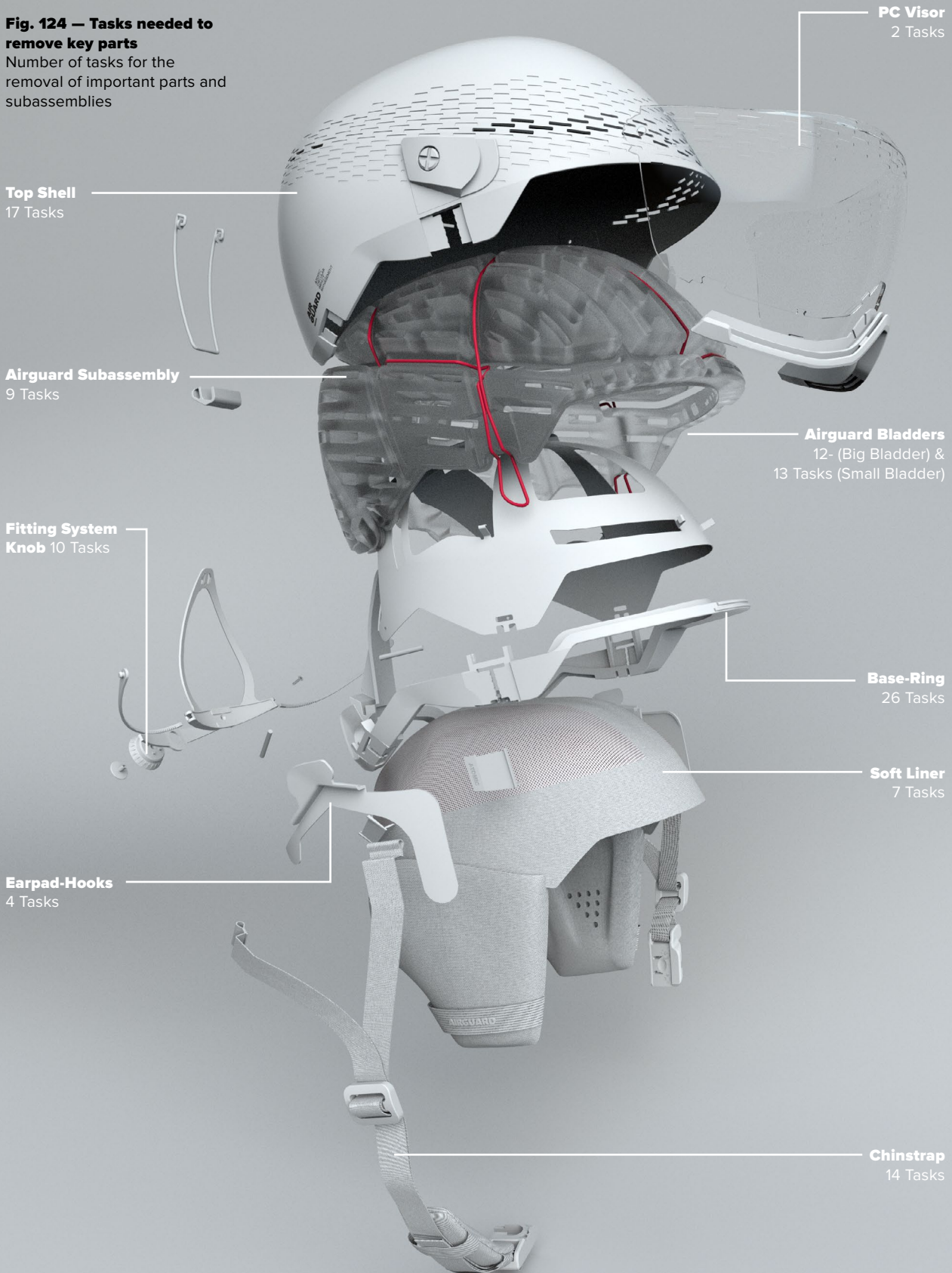

6.5.2 DISASSEMBLY MAP

Fig. 124 shows the needed tasks to dismount the most important product parts. This is either important for access in situations involving the harvesting of parts, for remanufacturing and recycling, but also for the user undertaking small replacements, like soft-liners and visors.

The core of the product, the Airguard system, can be removed within nine steps. The big and small bladder can be removed in twelve or thirteen individual tasks, respectively. The dome can also be removed within 13 tasks. The Soft Liner can be removed in seven tasks, including opening the buckle, pulling the chinstrap through its textile holders and then removing the friction fits and the soft liner from velcro elements on the inside. The Visor can be removed within two tasks. Compared to the baseline model (Tab. 6), this is an improvement. (Ten- and four tasks, respectively) Parts with more tasks necessary are the shell (17),

as it carries many other parts like visor and goggle retainer and the Base-Ring (26), as it also holds many different parts. The Atomic Savor GT AMID Visor shows two steps needed for this, yet this only accounts for the small, upper part of its shell. Furthermore, the earpad hooks can be removed in four tasks, and the whole fitting system in nine, compared to eleven in the baseline model. The chinstraps can be removed with the help of 14 tasks, which is the best value in the comparison, if the number in the POC model is disregarded as of its destructive nature.

Lastly, the fitting-system knob, the part that is in direct contact with the user's hands during adjustment, can be removed within ten steps, compared to twelve steps in the baseline model.

The re-design's full disassembly map can be found on the following page. (Fig. 125)

Tab. 6 – Number of tasks to remove different parts

A selection of priority parts and what it takes to remove them.

Chinstrap	14	18	19	18	28	13 (destructive)
Top-Shell	17	2	-	14	19	-
Fitting System	9	11	5	11	13	11
Soft-paddings & textiles	7	10	7	10	14	18
Soft liner	7	10	2	10	1	1
Neckpad	-	-	-	-	-	8
Earpads	-	-	5	-	13	9
Visor	2	4	2	-	-	-
Goggle retainer	9	10	-	10	6	4



Brand	Atomic	Atomic	Head	Atomic	Smith	POC
Model	Airguard	Savor GT AMID Visor	Rachel	Savor AMID	Vantage MIPS	Fornix SPIN

DESIGN

Disassembly Map Atomic Airguard



Parts

- 1 part
- 2 safety critical / hygiene priority Part
- A subassembly
- B resulting subassembly with included parts
- 3

Activities

- (H) hands
- (Sc) screwdriver
- (S) spudger

Indicators

- time intensive
- force intensive
- high precision
- un reusable fastener
- environmental impact
- economic value

Abbreviations

- PB Push Button
- SF Snap-Fit
- FF Friction-Fit
- VC Velcro
- HL Hook and Loop Fastener

Part List

- A Shell Assembly
 - 1 Shell
 - 2 Visor Nut M4
 - 3 Goggle Retainer Cord
 - 4 Goggle Retainer
 - 5 Visor Holder Cover
 - 6 Visor Holder Base
 - 7 Visor Screw
 - 8 Visor
 - 9 Visor face foam
 - 10 Visor bottom frame
 - 11 Locking Element Front
 - 12 Locking Element Back
- B Bladder Assembly
 - 13 Bladder Big
 - 14 Bladder Small
 - 15 Dome
 - 16 Liner Velcro
 - 17 Dome Padding
- C Fitting System
 - 18 FS Screw
 - 19 FS Knob
 - 20 FS Pin
 - 21 FS Gear
 - 22 FS Arms
 - 23 FS Top Cover
 - 24 FS Holder
 - 25 Chinstrap Pins
 - D1 Chinstrap Right
 - D2 Chinstrap Left
 - 26 Side Divider
 - 27 Chin Fabric
 - 28 Buckle
 - 29 Rubber Ring
 - 30 Chinstrap Webbing
 - 31 Soft Liner
 - 31 Earpad hooks male
 - 32 Base Ring

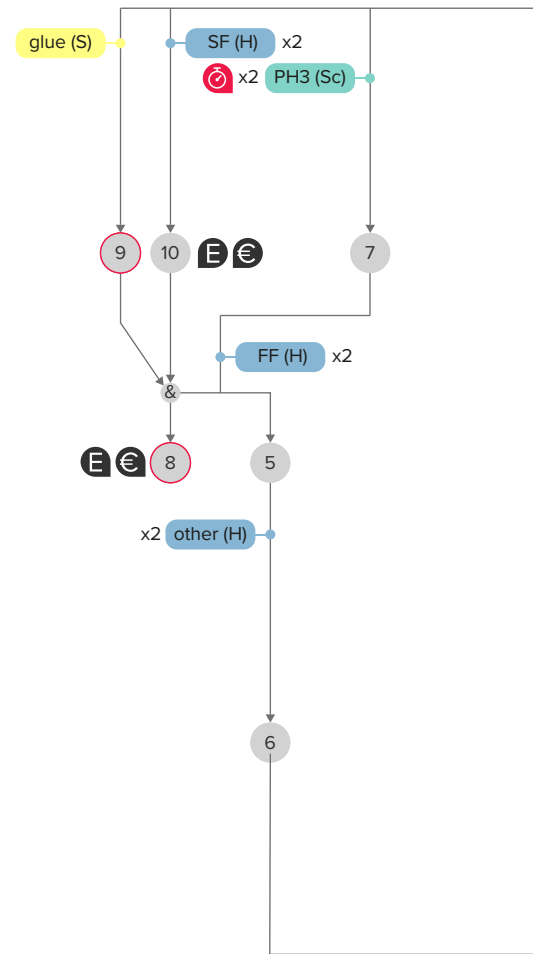

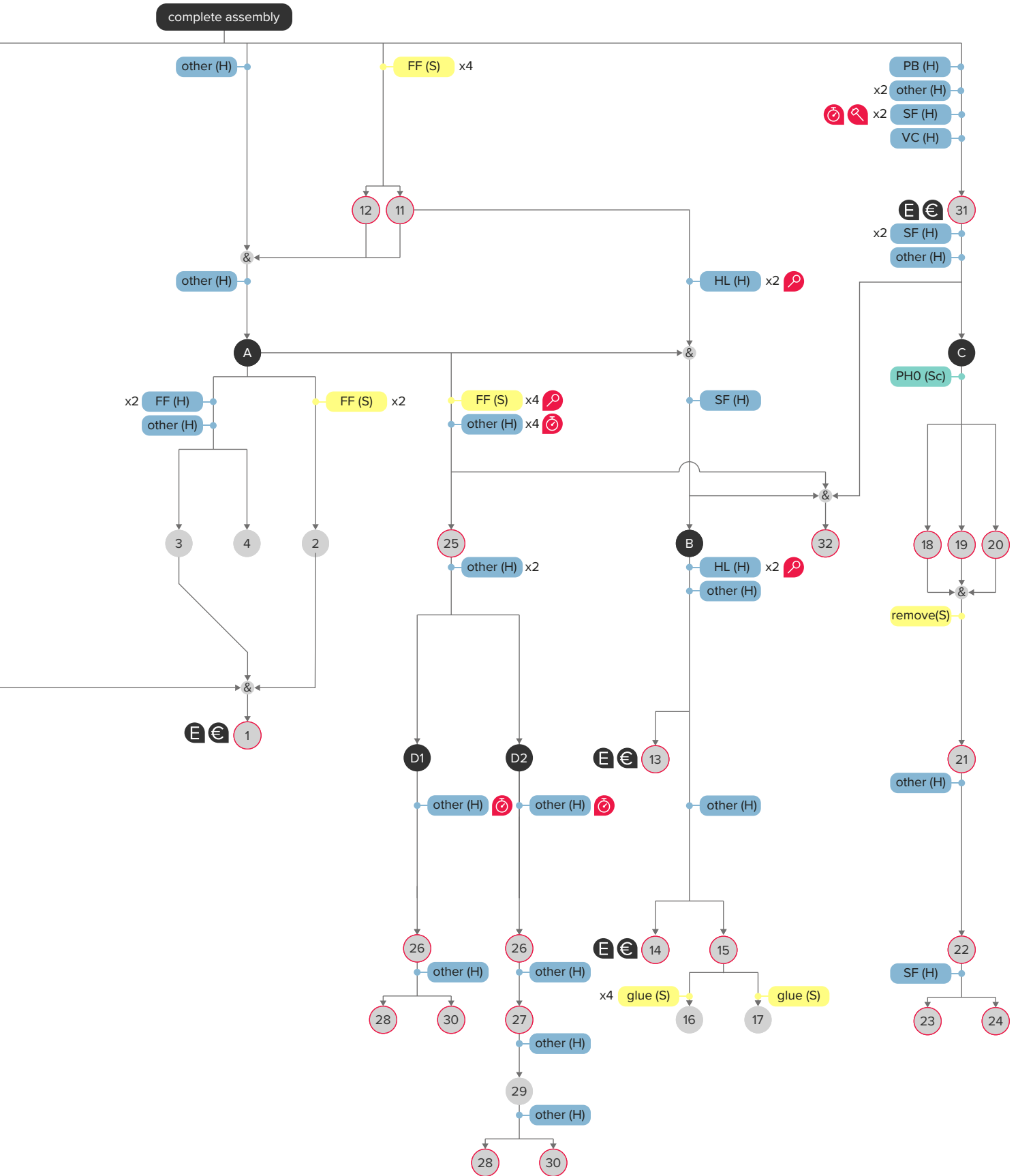

Fig. 125 – Disassembly Map Atomic Airguard

DESIGN

6.5.3 PRODUCT WEIGHT

The baseline model Atomic Savor GT AMID Visor was weighed at 670 grams. Compared to this benchmark, the re-designed concept currently shows a 15% increase in total product weight, at around 760 grams. (Fig. 126) The two major differences between the baseline- and the re-designed model are the novel form of energy management and the product architecture with focus on disassembly. Firstly, TPU, as the major part of energy management, accounts for the largest part of weight in the product (Tab. 7) and is considerably heavier than the baseline material EPS. However, this proposal can be considered a first concept — Further optimization and industrialisation can yield large improvements on the current state. Furthermore, the re-designed concept uses a full ABS-hardshell, compared to thin PC-shells and a smaller piece of ABS in the baseline model. Also in this case, further developments and material experiments can yield better results.

Material	Weight [g]	Material impact [g CO ₂ -eq]
TPU (Thermoplastic PU)	260,9	1500
ABS	210	725
PC	97,5	461
PA66 (Nylon)	86,8	558
Dacron (Polyester fibers)	78	351
Polyethylene Foam	23,1	74
Stainless Steel	9,1	30
POM (Polyoxymethylene)	0,5	2

Tab. 7 — Material-Weight and -Impact Atomic Airguard

Fig. 126 — Atomic Airguard Product Weight

Comparison with the benchmark product Atomic Savor GT AMID Visor

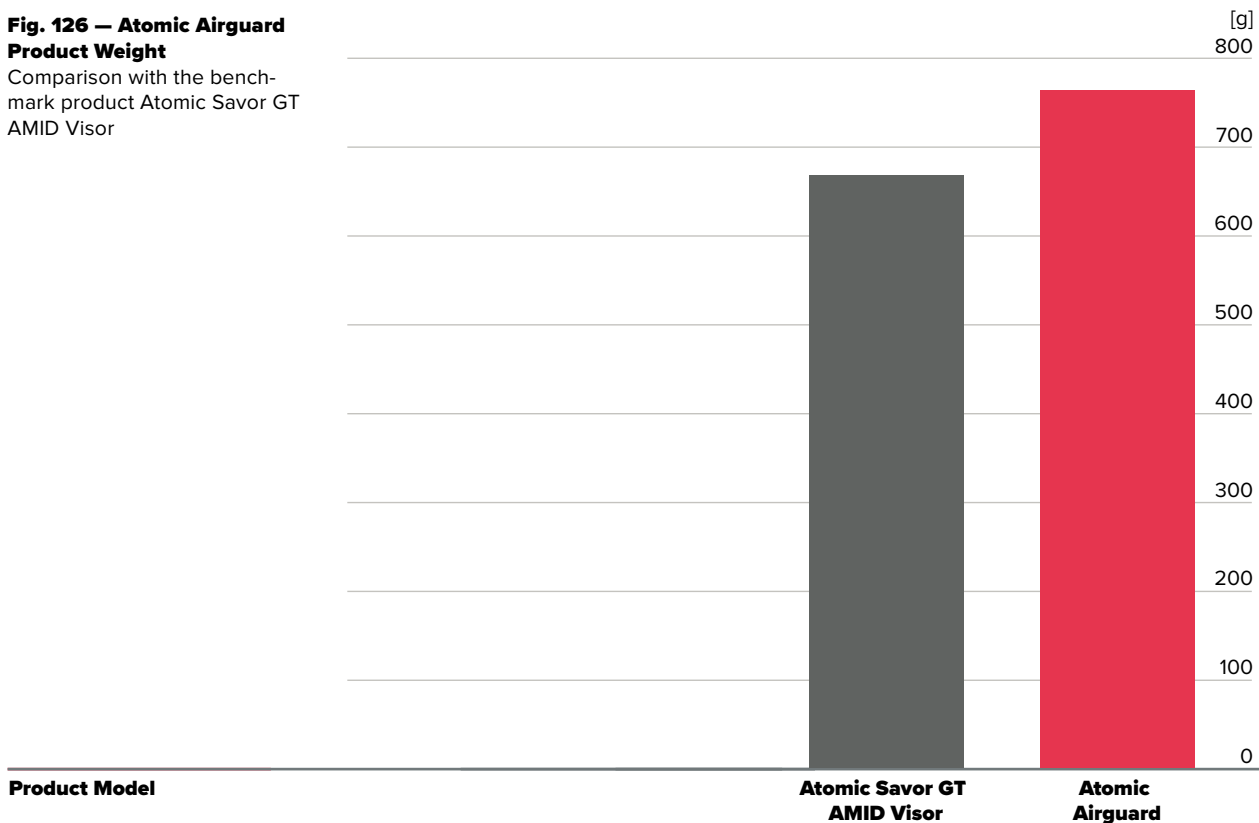

6.5.4 ECOLOGICAL IMPACT & ECONOMIC VALUE

Material Impact

Analogue to the difference in weight, the re-designed concept also shows significantly more impact, compared to the baseline model. The Savor GT AMID Visor was evaluated at 2,3 kg CO₂-eq., in material stage impact. The Atomic Airguard was evaluated at 3,7 kg CO₂-eq. Both values were calculated using the LCA-tool CES EduPack. (Fig. 127). The largest portion of impact stems from the TPU structure. The concepted structure within this product was measured at 261g, which already accounts for 1,5 kg CO₂-eq. The replaced material, EPS, weighed 160g and accounted for 380 g CO₂-eq, in the baseline model. Again, multiple steps of optimization can lead to improved results, looking at the structural design itself (e.g. wall thicknesses), and the type and shore hardness of TPU used.

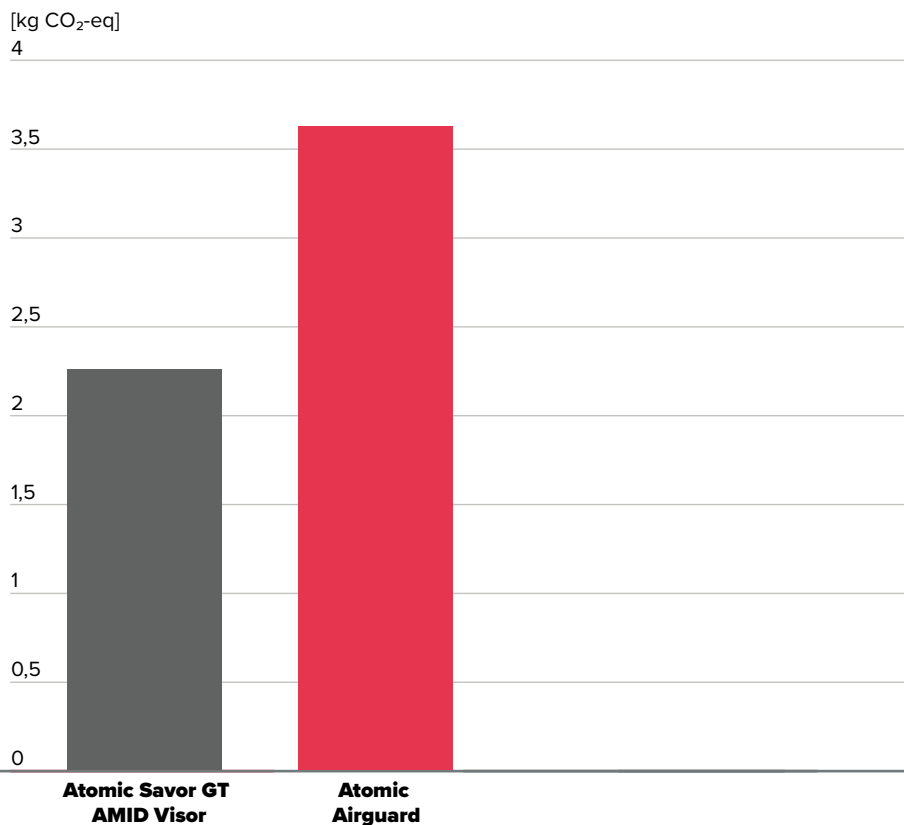

Fig. 127 — Atomic Airguard Material Impact
Comparison with the benchmark product Atomic Savor GT AMID Visor

DESIGN

Impact of Priority Parts

As stated in chapter 3.5.5, large priority parts have large influence on the product's total carbon footprint, the embodied energy and embedded economic value. Looking at the parts with the highest priority, either on the safety crucial- or the value-perception side. (Fig. 128)

Looking at the baseline product, seven individual parts with large priority and a total weight proportion of 61% of the total product accounted for 55% of the total embodied energy; 53% of the CO₂-footprint and 58% of the total economic value.

In the Atomic Airguard concept, the seven largest individual parts, which are also considered the main priority parts, account for around 88% — In weight, impact and value.

Fig. 128 — Proportions of Weight, Impact and Value

Comparison of the proportions in impact and value of individual parts of the Airguard concept

PC Visor The visor, as purely ergonomic element distributes an even amount of 10% over all impact sections

Soft-Liner Polyester and PE foam has a medium amount of weight and impact.

Base-Ring The PA66 part has large amounts of impact and value, compared to its weight.

ABS-Shell The part makes a large part of the weight, with decreasing proportions in impacts and value.

PC Structural Dome The structural dome in the Airguard system has minor weight, impact and value, yet can be removed in combination with the TPU parts.

TPU Airbladders The parts have the largest portion of weight, embodied energy, CO₂-footprint and economic value. The impacts and monetary value are over-proportionally distributed. Compared with EPS, TPU has more impact and value in relation to its weight.

RE-DESIGN EVALUATION

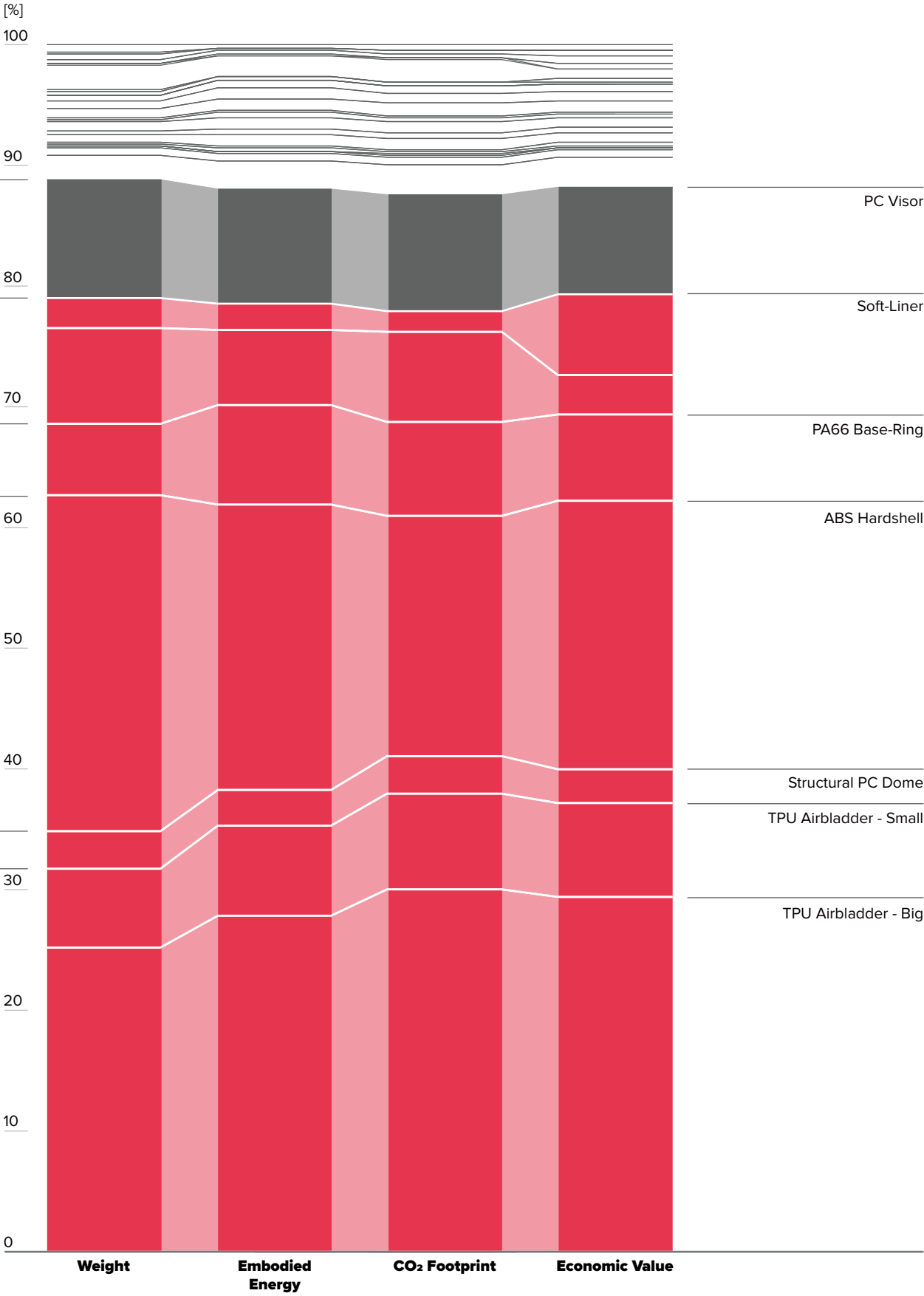

DESIGN

6.5.5 END OF USE & END OF LIFE SCENARIOS

Only looking at the proportion of impact and value of the before mentioned seven individual parts does not yield a clear view on sustainability yet — especially when considering the significant increase of total impact.

For a better impression of the improvement of impact, a further stage of the product lifecycle has to be considered: The product's end of use (EoU) and end of life (EoL).

Baseline Model

The CO₂-impact on material level of the baseline model is considerably low, compared to the re-designed concept. However, as this is only the material stage, further impact must be considered for a comparison. The current product's EoL, at best, involves incineration, a process that has the mere focus on recovering some of the product's embodied energy. Next to this, it further emits CO₂. Fig. 129 shows, that the energetic recovery emits another kilogram of CO₂-equivalent.

Airguard Recycling

The Airguard concept has a significantly increased impact, even compared to the baseline model and the EoL scenario added. This is where recycling scenarios come in to decrease CO₂-impacts:

- Recycling Scenario 1 (Recycling of Main Parts) — This scenario involves the recycling of the seven biggest parts, analogue to the parts in focus in Fig. 128. The parts would be collected and then undergo controlled recycling, either by a third party or the part manufacturer itself. This would regain more than 50% of CO₂ emitted.
- Recycling Scenario 2 (Full Recycling) — Additionally to the recycling of the main parts, all other parts would also undergo a controlled collection and recycling process. Considerably, the proportion of CO₂ saved would only be increased in a small amount, yet the total amount of avoided carbon footprint would be over 2 kg CO₂-eq.

Fig. 129 — Comparison of Impact in different scenarios

Comparison between the incineration of the baseline product and different scenarios of recycling and remanufacturing.

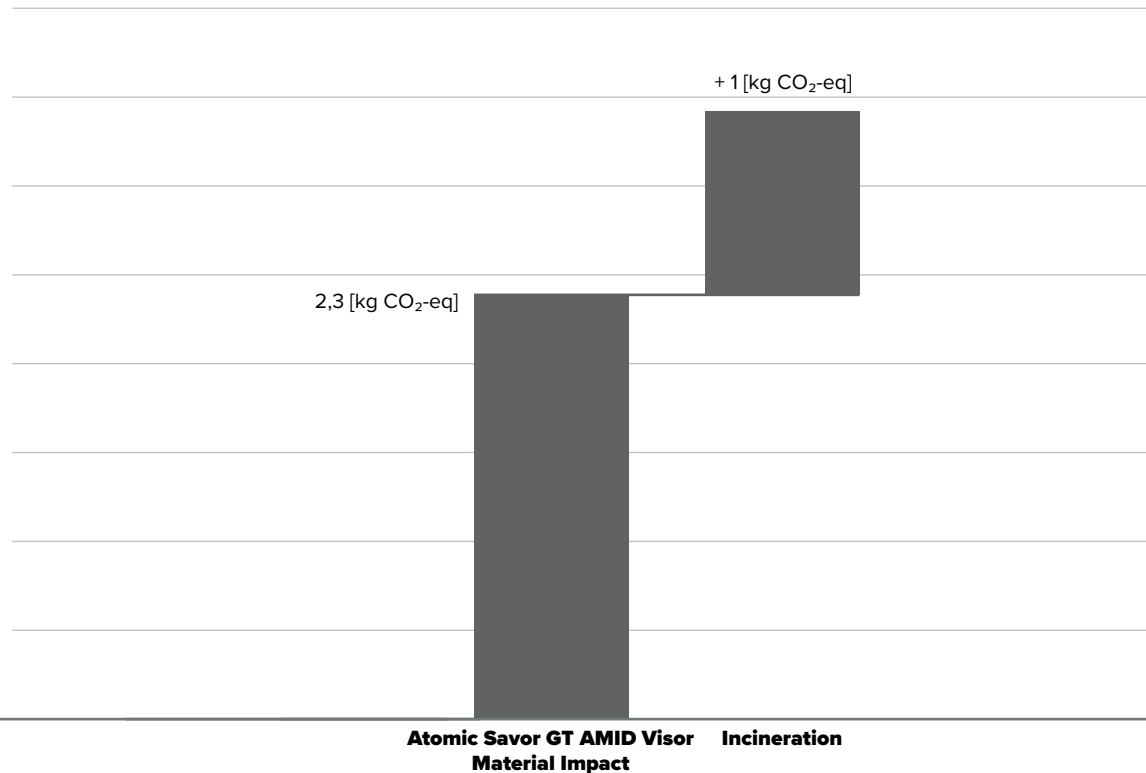

Airguard Remanufacturing

With further re-use of parts, even more impact can be avoided:

- Remanufacturing Scenario 1 (Remanufacturing of Main Inside Parts) — Durable inside parts, like the Airguard system including the dome, the Base Ring, and PA66 parts like the fitting system and earpad hooks can be the subject of remanufacturing. This would further decrease the total impact by 740 g CO₂-eq.
- Remanufacturing Scenario 2 (Remanufacturing of Main-Parts) — This scenario furthermore includes remanufacturing the shell. This would save an additional amount of 245 g CO₂-eq.

In the remanufacturing scenarios, all parts not involved in remanufacturing would undergo controlled collection and recycling.

Maintaining and Increasing Product Value

This evaluation only considers impacts saved or prevented through recycling or a combination of recycling and remanufacturing. It does not consider the prevented impacts that stem from using products longer and therefore postponing buying a new product. Measures like cleaning or replacing soft-liners as a preventative action to maintaining perceived product value, or upgrading a helmet with a visor and increasing the full product life also have the potential to prevent impact.

In reality, a combined palette of measures to prevent and regain emitted CO₂, embodied energy and value have to be set in place.

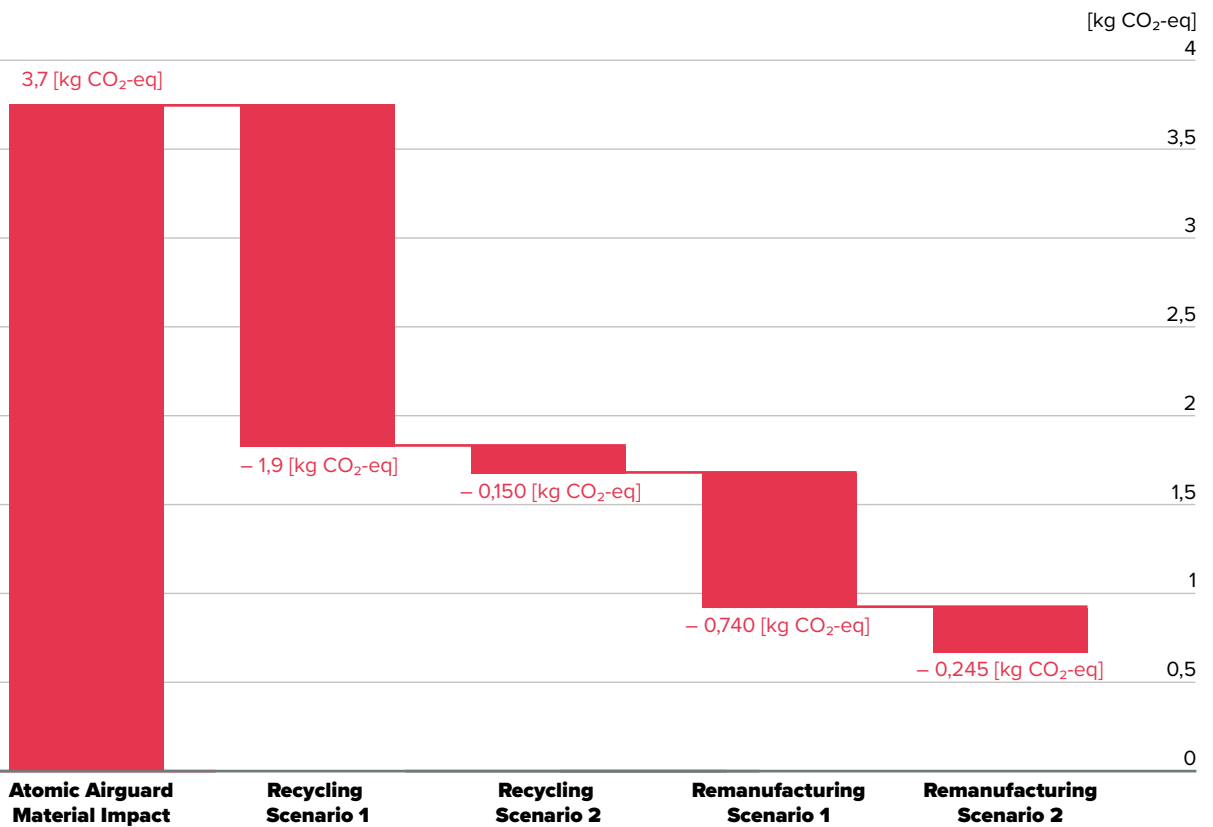

DESIGN

6.5.6 TECHNOLOGY READINESS

The Atomic Airguard concept is a proposal for an improved energy management system, with multiple future possibilities to further improve ski-helmets in impact scenarios and provide improved protection and functionality to users. The concept includes a proposal for innovative properties for easy disassembly and making the product available for controlled recycling and remanufacturing to prevent impacts made — and value lost. The concept includes the possibility to replace parts, yet also to upgrade different functions. The Atomic Airguard should stand as a vision-concept for a sustainable revolution.

Technology Readiness Levels

The Airguard system currently bases on ‘Proof of Concept’-testing, on the case study of Schutt football-helmets and the research conducted by Tanaka et al. (2009). In the system of ‘Technology Readiness Levels’, or TRLs, it would be located in TRL3 — ‘Proof of Concept’, with the next step being concept validation. (Smulders, 2019; Fig. 130) As this is still considered a ‘Laboratory’-stage, it is still far from becoming a production-reality. Other proposals within the concept are closer to a real product. The product architecture with fixations focused on mounting elements either to a structural base structure and the helmet’s hardshell are close to feasibility. They still demand fine-tuning, testing and possible iterations but these measures can already be considered part of ‘Product Development’, and therefore are located between TRL6 (Demonstrate Design) and TRL7 (Demonstrate final Design). The same is true for fixation solutions enabling upgrading the product, which can be industrialised in a short time. The Technology Readiness Levels stretch over nine different stages, with production & deployment in TRL8 and TRL9. (Fig. 131)

The In-between Step

The Airguard concept stands as a future vision, it should propose possible directions for the brand’s product designers to design future sustainability into their products. However, considering the low TRLs of some product features, some parts of the concept can be used already in near-term product development. This can be used to improve the product’s sustainability, yet also to prepare, test and analyse design decisions for further concepts.

Fig. 130 — Technology Readiness Levels

TRLs and their implications in Design, Testing and Industrialisation (Smulders, 2019; own visualisation)

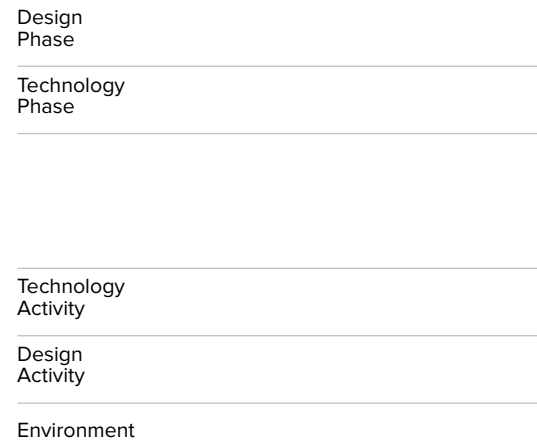
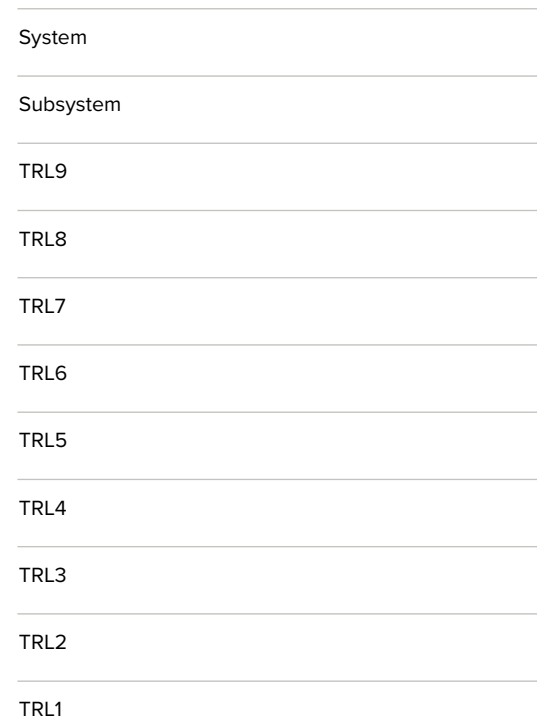

Fig. 131 — Atomic Airguard Technology Readiness

Technology matureness of different product features within the proposed concept



6.6 AIRGUARD SHELL

The Airguard technology proposes a new direction within the helmet industry. To communicate this also in a novel way, the helmet's exterior should visually derive from known helmet shells. Current helmets — and this is true to most available brands and models — use exterior shells with added material and gaps, or separate parts (Hybrid constructions between in-molded- and hard-shells) for creating the brand's desired styling lines and identity. Furthermore, this includes large holes in the front, the rear and the top for ventilation, which also add to the helmet's styling. (Fig. 132 to Fig. 134) As this is mostly connected to the geometries available in the EPS-in-molding process, the Airguard concept should develop a different, more conceptual styling.

Inspiration

The Airguard system with its main functionality — the usage of air-flows to dampen an impact (next to the deformation of TPU) — proposes an interesting metaphoric connection. The connection can be made to air and to wind and the effects these have on their environment, like transporting particles, from a dense structure to a light mix of particles and air. Particles can also be found in surface patterns, or hole patterns, following the same gradual approach, transforming between a solid structure and a more mesh-like — open structure.



Fig. 132 — GIRO Aria (Pomelo-Sport, 2021)



Fig. 133 — Head Rachel (Snow-How, n.d.)

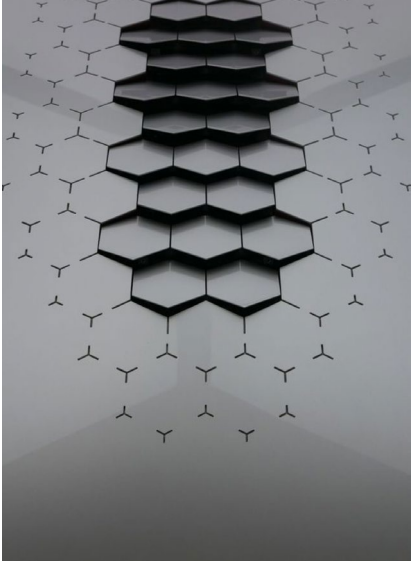
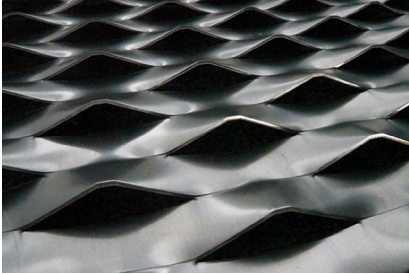

Fig. 134 — Atomic Savor GT AMID Visor

- Fig. 135 — Wind Particles 01 (Chaudhry, unsplash.com)
- Fig. 136 — Wind Particles 02 (Hasselmann, unsplash.com)
- Fig. 137 — Wind Particles 03 (Tamasi, soundcloud.com)
- Fig. 138 — Stretch-metal (GTI-Gitter, n.d.)
- Fig. 139 — Surface Pattern (Pinterest, n.d.-1)
- Fig. 140 — Facade panels (Pinterest, n.d.-2)
- Fig. 141 — Gradual Air Inlet (Pinterest, n.d.-3)
- Fig. 142 — Gradual Pattern Holes (Pinterest, n.d.-4)
- Fig. 143 — Car-Seat Pattern (Pinterest, n.d.-5)

(Figure order follows reading direction)

AIRGUARD SHELL



DESIGN

The styling-process started with sketches, finding a visual language that fits a modern conceptual helmet. As the Airguard concept evolved more, it became apparent that the surface styling needed a change towards a different direction, as described on the previous page.

The surface styling was then iterated to holding many small holes, opening the structure in places where ventilation is needed, and then gradually transitioning into a closed, solid surface. This pattern was linked to a pattern defined in the Atomic Style Guide, a pattern related to the Atomic logo-sign in its dimensions. (Fig. 145) The combination of this pattern and the inspiration found on the previous page led to the final surface pattern used. (Fig. 146) It should resemble a dense structure in the front, with the wind then dissolving the structure towards the end, transitioning from a broad surface to a thin line in the end, only opening needed holes for ventilation. The Air-pattern starts on the shell, and then subtly stretches onto the visor, to create a shading area on top of the piece, analogue to a sunshade in car-windows.

The remaining surfaces on the helmet were left clean, with only using branding elements in small extents. The goggle retainer cord is integrated into the pattern, leaving the shell through ventilation holes.

To link the TPU-structure and the outside of the helmet, the TPU-columns were also designed analogue to the used Atomic-own pattern.

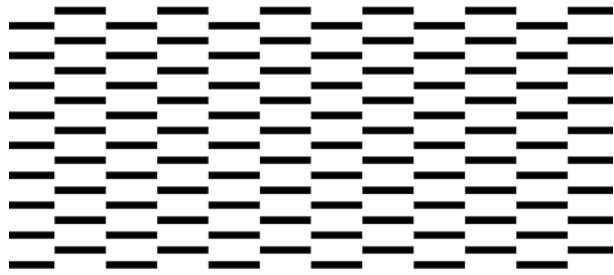

Fig. 145 – Atomic identity pattern

Fig. 146 – Airguard Concept with characteristic surface pattern

The defined Air-pattern on hardshell, visor and TPU-airbladder

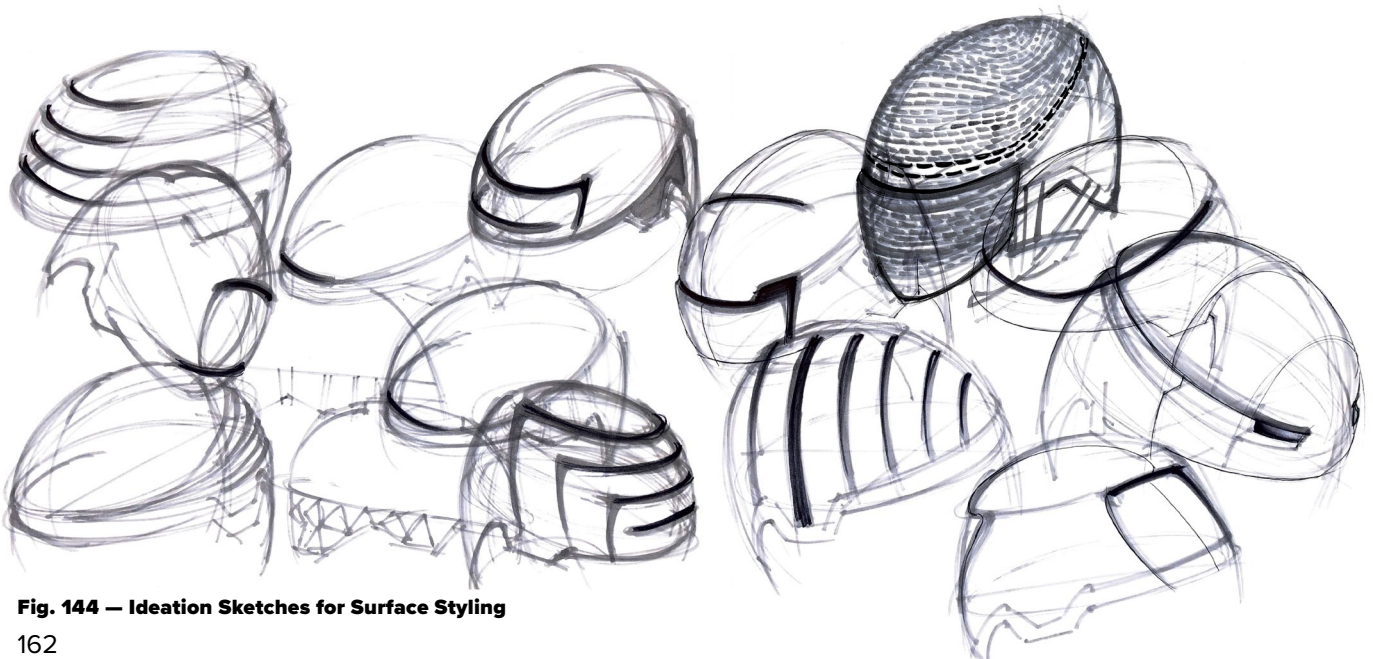
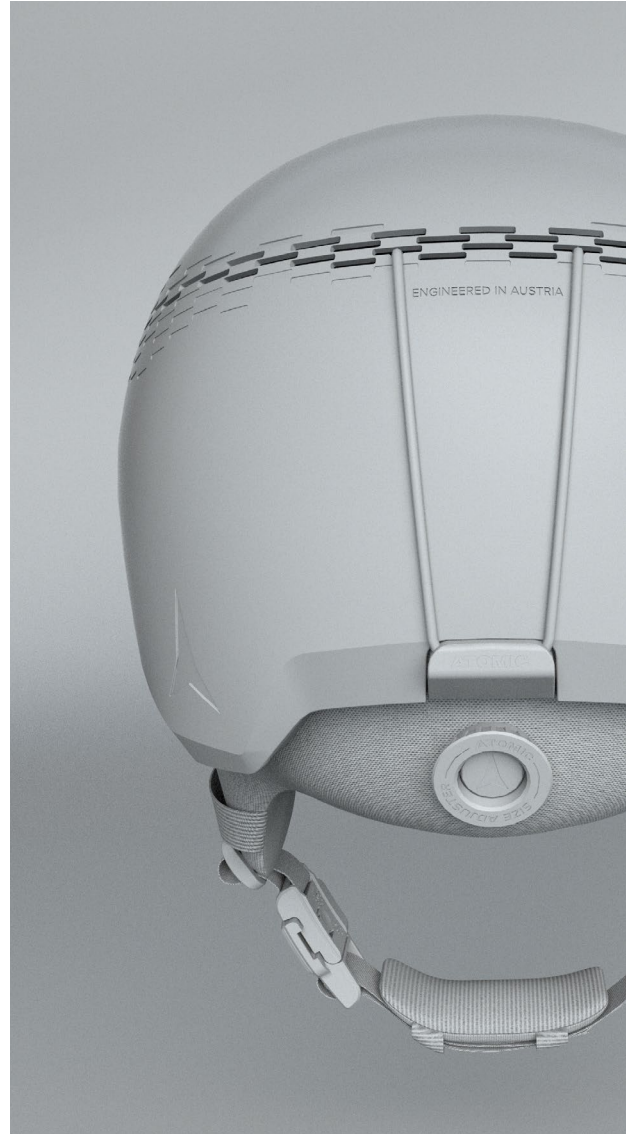
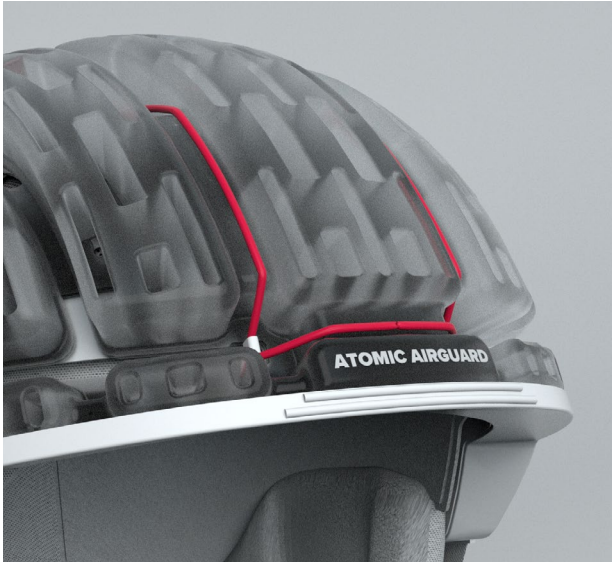
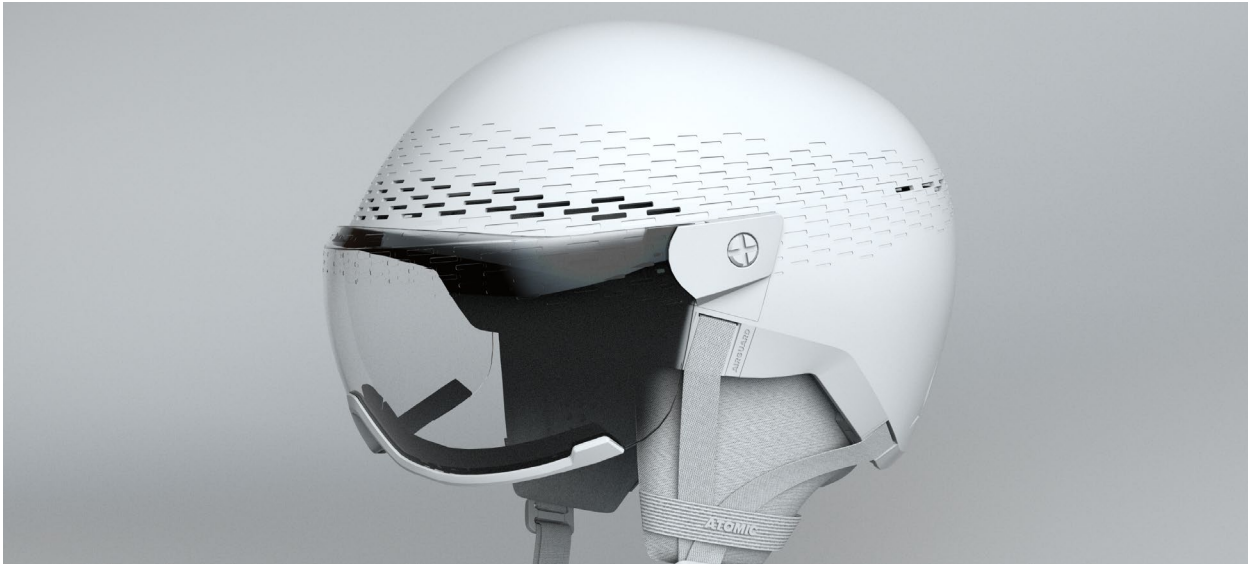

Fig. 144 – Ideation Sketches for Surface Styling

AIRGUARD SHELL



6.7 SUSTAINABLE EVOLUTION

Atomic Eco-Savor

The proposal for an intermediate step — the sustainable evolution — should include product features within the proposed concept that are close to production and deployment (TRL8 & TRL9).

The concept — Atomic Eco-Savor — is a proposal for full disassemblability. It is built on the product architecture-base of the Airguard concept, yet uses an EPS-liner for impact management. EPS known form of energy management.

The base of the structure is the durable Base Ring made from PA66. This foundation holds the earpad-hooks and the chinstraps. Furthermore, connected to the rear tongue, the fitting system is set into place. A difference is, due to the absence of the Airguard system, that a separate fixation is set in place to hold the current LiveFit Ring, Atomic's current proprietary size-fitting headband. This connection is made through side-tongues with integrated pins for a snap-fit connection. Without the Airguard-system, no fixation hooks are needed to hold the TPU-cord and the adjacent TPU-bladders.

The Base Ring holds the EPS-core in place. This core is inserted into the ring from the top and is held by the ring's outside walls.

Then, the known hardshell subassembly, including visor and goggle retainer closes off the assembly, following the same rotational movement as seen in the Airguard concept, including pulling through the chinstraps as main fixation elements. Afterwards, the side closing-elements create the needed fixation to securely lock shell and ring together.

The concept also includes the possibility to exchange and clean soft-liners, yet also the upgrading to different functionalities. From using the helmet with goggles to using a visor, equipping the model with chin-guards for ski-racing, amongst others.

Focus on Recyclability

This concept focuses on sustainable re-design for enabling proper recycling of ski-helmets. The product architecture allows access to all parts and gives the possibility to separate, collect and recycle all parts made from different materials.

Similar to the Airguard Concept, ideally every single part would be recycled. Yet, even recycling of the main biggest parts would decrease the total impact. This would include the shell, the EPS-core, the bottom ring, the visor and the soft liner. (Fig. 147)



Fig. 147 — Atomic Eco-Savor

The in-between concept for sustainable evolution uses a similar approach on product architecture, yet uses a tried and tested EPS core for energy management

DESIGN



Product in Use

Up-Trade Collection Structure

Collection Process

Part Separation

Part-Health Analysis

Closing the Loop

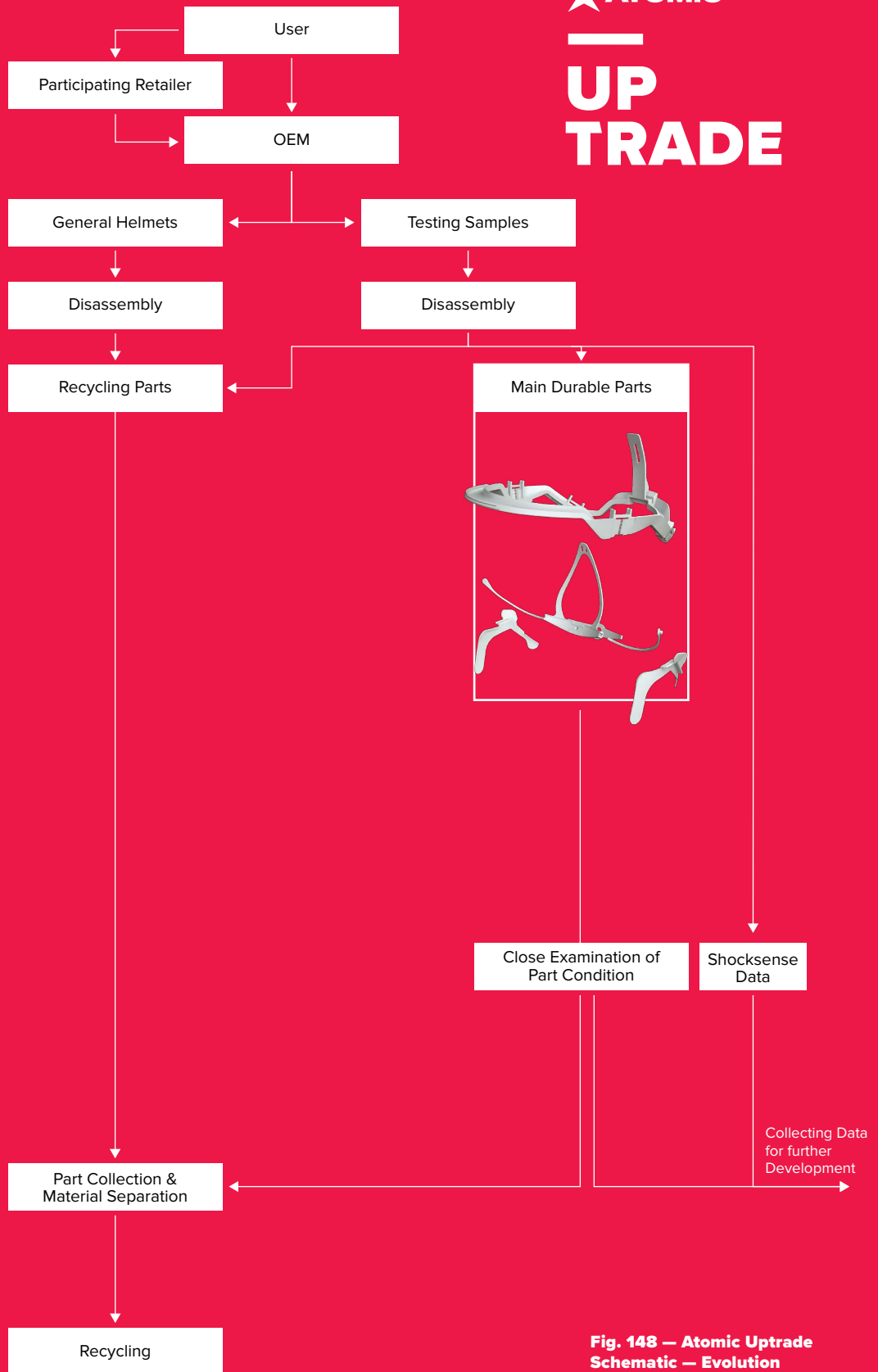

Fig. 148 — Atomic Uptrade Schematic — Evolution
 Description of the removal of soft liner and the visor

Take-back Programme

To ensure controlled recycling, the take-back programme proposed in chapter 6.3.4 should be set in place for the evolution concept. Within this system, incentives like discounts should be rewarded to customers that retrieve their helmets. These are to be collected, disassembled and the harvested parts recycled. (Fig. 148)

Remanufacturing Ramp-Up

As preparation for the remanufacturing schematic within the Airguard system, similar parts can already be analysed and tested, focusing on their durability and suitability for remanufacturing. Parts like the Base Ring, but also shells, amongst others, can be analysed on their structural health. These findings should be documented and be used to guide further development steps.

As a further step of building a database on impacts and their consequences on part health of structural parts, a defined amount of testing products can be launched. These test products can be equipped with Atomic’s active impact-sensor and are connected to a mandatory take-back system. After retrieving, the data collected on impact scenarios can further feed into a database. To increase the relevancy of this testing round and the impact on part-durability, the testing group can include ski-racers as they are more prone to receiving impacts from slalom gates.

Weight and Impact

The product within the evolution concept weighs 676 grams, compared to 670 grams of the baseline model. Even as the weighs are almost similar, the impact of the evolution concept is slightly increased. While the materials used in the baseline model accounted for 2,3 kg of CO₂ equivalent, the re-designed model reaches a level of 2672 grams of CO₂-eq. The increase stems from the increased impact ABS has within the compound. The 210g of ABS are responsible for 725g of CO₂-eq. on the material level, compared to a 130g EPS liner with 309 g of carbon footprint on the material level.

Material	Weight [g]	Material impact [g CO ₂ -eq]
ABS	210	725
EPS	130	309
PC	97,5	461
PA66 (Nylon)	86,8	558
Dacron (Polyester fibers)	78	351
PE Foam	23,1	74
TPU	20,9	120
EVA	20	42
Stainless Steel	9,1	30
POM (Polyoxymethylene)	0,5	2

Tab. 8 — Material-Weight and -Impact Atomic Airguard

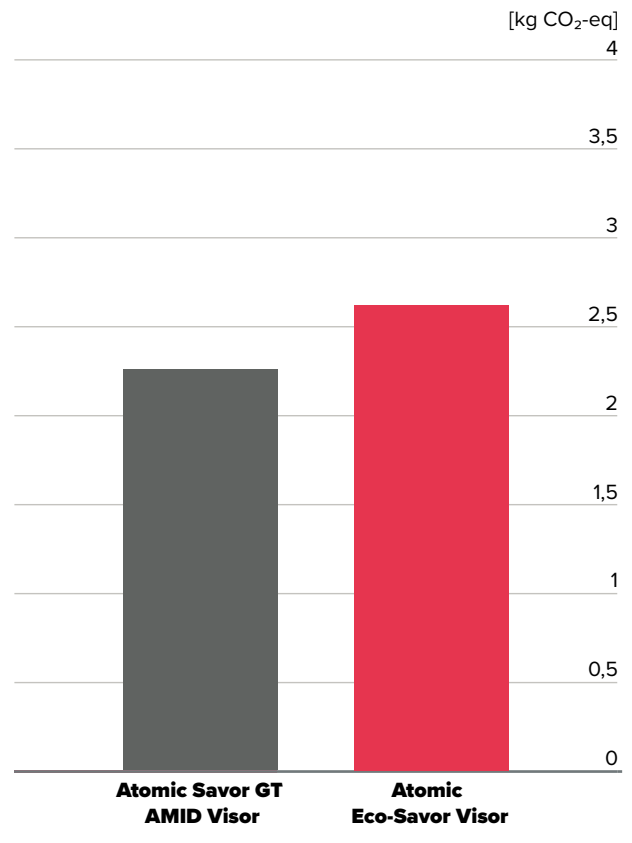

Fig. 149 — Atomic Eco Savor Material Carbon Footprint
The evolution concept’s CO₂-impact, compared to the baseline models value





7 DISCUSSION & CONCLUSION

The most important aspects of the proposed re-designed are analysed and brought into perspective of People, Planet and Profit. The last set of sub research-questions will be answered, leading to a client advice, using a roadmap. The conclusion will provide recommendations, but also will put the product ski-helmet into the bigger picture.

7.1 DISCUSSION 172

**7.2 ROUTE TO
CIRCULARITY 176**

7.3 CONCLUSION 180

7.1 DISCUSSION

This thesis focused on re-designing current ski-helmets into a vision-concept for the company Atomic as a guiding element in their pursuit of a more sustainable product portfolio. The project included research in current consumer behaviour with (ski)helmets, product architecture and resulting disassemblability. The main priority-parts within helmets are safety crucial, yet many parts can also be considered crucial for perceived value. Furthermore in focus was the current product's economical value and environmental impact, resulting in indicating additional priority parts through the HotSpot-Mapping tool.

Lastly, research was conducted in the possibilities of transitioning ski-helmets into the Circular Economy, the current limitations in certification and liabilities and the future prospects, which could influence the product-segment.

Current helmets are considered as single impact items, yet they are not only discarded because safety critical elements were subject to damage, but also because parts with crucial perceived value are linked to deterioration from wear and tear. About 40% of users replace their helmets because of technological or emotional obsolescence, resulting from wear and tear. When these products are then discarded, they are rarely disassembled for recycling. Priority parts are not easily accessible and subassemblies often cannot be removed in one piece. Even as there are practical — non destructive — fixations in place, many parts can only be removed in a destructive matter. This is especially true for the EPS in-mold assembly — an industry standard and commonly found in most available helmets. It holds the majority of parts within the helmet safely in place, however it prevents further disassembly and narrows the window of EoL-opportunities to merely incinerating the compound. EPS is also amongst five parts holding the majority (55%) of the product's material impact. Material makes 73% of the full lifecycle-impact, accounting for 2,3 kg CO₂-eq., on average.

Current developments in ski-helmets already focus on sustainability, however this is mainly limited to Eco-Design or even greenwashing. Customers become aware of these developments and are

becoming evermore suspicious of false claims in sustainability. Positively, users would be open for sustainable options and clear communication thereof — which are lacking, as ski-helmets are currently not following the concepts of the Circular Economy.

Which development aspects need to be considered when embedding highly integrated & safety critical consumer products with crucial perceived-value into the framework of the Circular Economy?

Main research-question

After summarising all relevant research-findings, a concept was developed, following a re-design of product and services. Following this, the last set of research-questions can be answered, including the main research-question. The statements can be found on the following pages.

1

Maintaining, upgrading, remanufacturing & recycling are the suitable strategies for ski-helmets.

RQ4 How can ski-helmets be re-designed to fit into the concept of the Circular-Economy, in a timeline of five years?

RQ4.1 Which strategies of the Circular Economy fit to ski-helmets?

Ski-helmets should become sustainable by not only looking at their primary impact, but rather on maintaining their value over a longer period of time, with the possibility to even increasing value and decreasing impact. All parts should be able to dis- and re-assemble for recycling, but also remanufacturing, with suitable materials in use.

Some parts with crucial perceived value are not safety crucial, like soft-liners and visors. These should be replaceable by the user. The assembly-base of the visor should stand as a modular base for upgrading the helmet from goggle use to visor – and make it adaptable for usage of lamps, cameras, chinguards, e.g.

2

A multi-impact energy management system, suitable for remanufacturing as vision for sustainable ski-helmets.

RQ4 How can ski-helmets be re-designed to fit into the concept of the Circular-Economy, in a timeline of five years?

RQ4.2 How can the main functionality be re-designed to fit the Circular Economy?

The Airguard concept stands as a sustainable vision — a solution for a product architecture that is ready for assembly and disassembly, but also a novel way of energy management. The impact management system within — a system combining the elastic deformation of TPU with the controlled decrease in pressure of air-bladders equipped with orifices. The system can be subject to multiple impacts without deterioration and can be cleaned and reconditioned easily, therefore be put into remanufacturing and used in new helmets.



Fig. 150 — Atomic Airguard from the rear

3

Combining full disassemblability and mono-materiality are go-to directions towards Circularity.

RQ4 How can ski-helmets be re-designed to fit into the concept of the Circular-Economy, in a timeline of five years?

RQ4.3 How can the product architecture be re-designed to fit the Circular Economy?

The product architecture was re-designed for full disassemblability, to a point where all materials can be separated and collected for recycling. This was achieved by separating the accessibility for parts considered as safety crucial and parts that are merely connected to crucial perceived value. All safety relevant items can be removed after removing the hard-shell — by only using connectors that can be re-applied. For all other connections, indestructive solutions were used. The secure access through the hard-shell was also used to create a singular direction to mount and dismount crucial parts, without alternating the position of the product. Connections like chin-straps are now accessible from the outside.

Compounds, like the Airguard system were designed as a monomaterial structure, with functional elements and fixation elements being made from one material — TPU.

Fig. 151 — Comparison of Impact in different scenarios

Comparison between the incineration of the baseline product and the possible impact of sustainable evolution and revolution

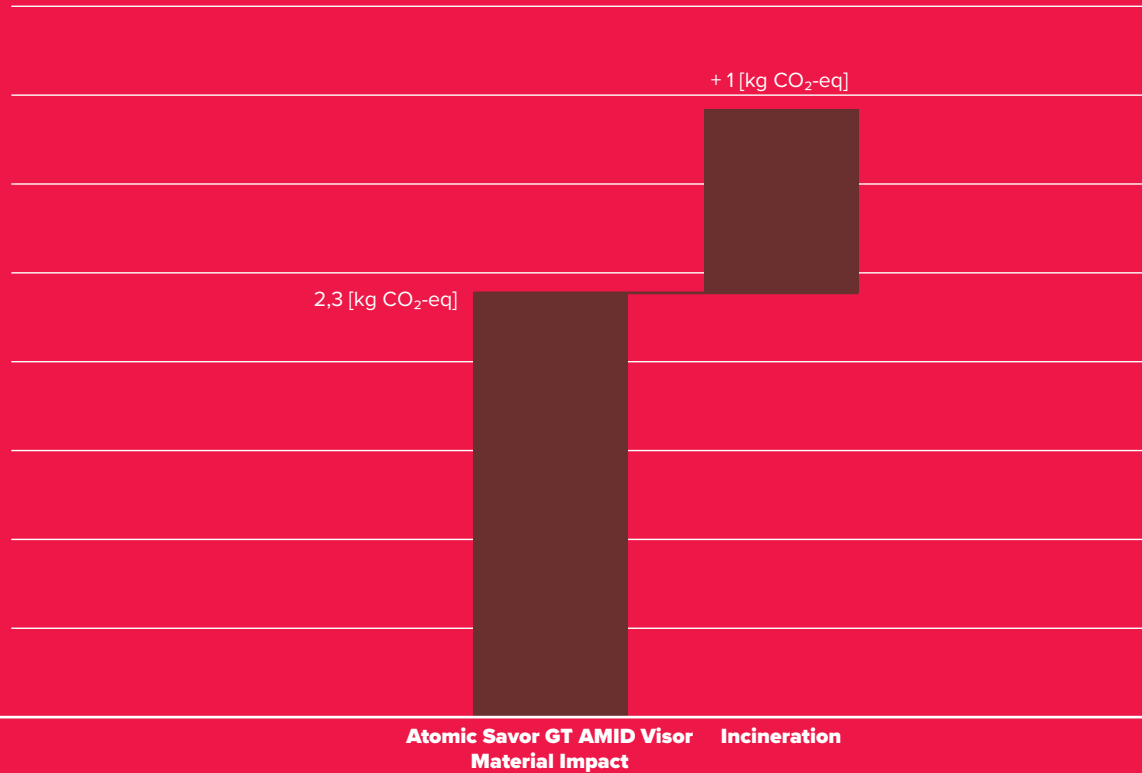

Product Model and Impact Scenarios

4

From Evolution to Revolution. Step – By – Step decreasing impact towards Circularity.

RQ4 How can ski-helmets be re-designed to fit into the concept of the Circular-Economy, in a timeline of five years?

RQ4.4 Are there necessary intermediate steps to achieve the desired concept?

The two concepts — Atomic Eco-Savor and Atomic Airguard — propose a gradual build-up of sustainability within Atomic's helmet portfolio. From introducing recyclability through a re-designed product-architecture to rethinking energy-management for remanufacturing. Fig. 151 shows, that by following this approach, the impact can be gradually reduced. In the baseline-model, the impact increased over its whole lifecycle, as it was incinerated at its EoL. The Eco-Savor, with the concept of recycling only main parts (EPS-core, shell, base-ring, visor, soft-liner) already decreased the impact on material level to ca. 1,5 kg CO₂-eq., compared to a sum of almost 3,5 kg of emitted carbon in the baseline model.

Adding remanufacturing to the calculation, combined with full recycling of parts that cannot be subject to remanufacturing (yet), the CO₂ footprint of the used materials comes down to under 1 kg CO₂-eq.

Furthermore, the possibility of upgrading, washing, cleaning and replacing parts that are not subject to certification can improve product longevity, therefore also gradually decrease the impact over time.

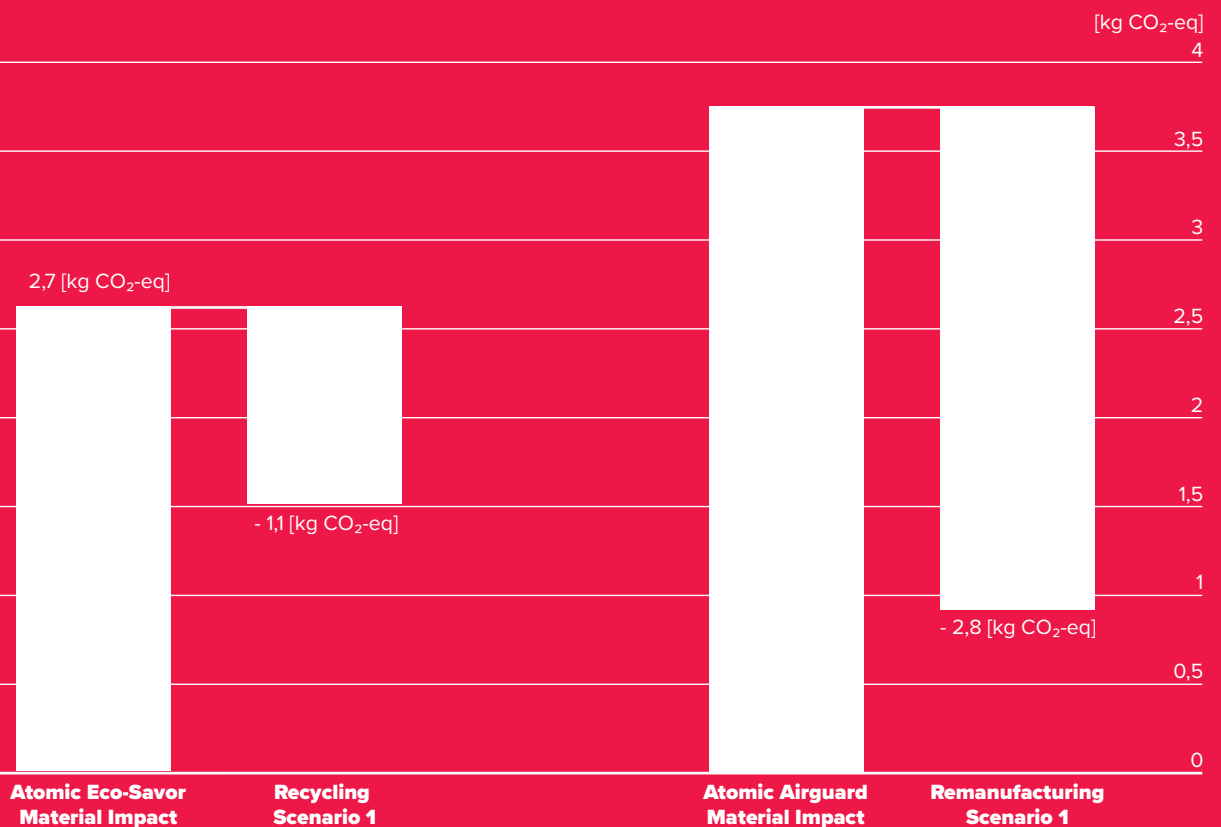



7.2 ROUTE TO CIRCULARITY

Transforming ski-helmets into a sustainable future demands time for industrialisation and steps in-between to develop products, services and networks for facilitating circular flows. The timeline until production of the Airguard (Fig. 153) is estimated on six years. The re-designed Atomic Eco-Savor (Fig. 152) and the Atomic Up-Trade system should be released within three years. (Fig. 154)

Airguard Development

The Airguard concept needs to be further developed and tested, with the focus on gaining knowledge on its feasibility. From validating concepts and designs (TRL4 - 5) to developing a final design for industrialisation, certification and launch. (TRL8 - 9) Within this timeline, the impact indicators should be developed and integrated into the system.

Design for Disassembly

For the evolution-concept, but also following steps, the current product assembly should be developed into a product architecture with full disassemblability. Development steps should include testing from the start, guaranteeing its proper functionality and safety.

Take-Back System

The Up-Trade system enables retrieving used products and controlled recycling and remanufacturing cycles. It can be trialled before releasing the Eco-Savor, aiming at nudging customer behaviour and preparing customers for upcoming services. Within this time, a network of participating retailers should be built, acting as decentralised collectors of the brand's products. In year two, the system should be launched, with discount-incentives.

Circular Flow Network

The usage of sustainable materials is crucial for this project. Therefore, a network of suitable suppliers should be built, including OEM part-man-

Fig. 152 — Atomic Eco-Savor with Main Concept Parts

A proposal for a sustainable evolution with full focus on recycling and building the base for the Airguard-concept

ufacturers and their suppliers. The network should be prepared for facilitating suitable recycling and making use of recycled materials. Partnerships should be built to put Atomic's collected and sorted materials into controlled recycling, with feeding these back into the production loops. If Atomic needs its own materials back into their product should be in question, rather it is important to — after fully recycling — use secondary-sourced materials for part production. As material health is essential for safety-crucial products, chemical recycling can also be subject to testing, as it enables the full regaining of material properties after recycling. (Jos Oberdorf, 18.05.2021, Appendix I)

Remanufacturing Ramp-Up

With the release of the Airguard-helmet, the Atomic Up-Trade system should be used to collect healthy parts and re-using them within new products. With the release of the Eco-Savor helmet, the Up-Trade system should be used to analyse parts used for remanufacturing. The focus should lie on investigating durability and building a database on these properties. The database should be used for improving parts for part-remanufacturing and building a knowledge base on their expected lifetime. This is important for further certification processes. With a solid expectancy of part health after prior use-cycles, certification processes could also include pre-used remanufactured parts. (den Hollander, 03.06.2021, Appendix J)

For more specific gathering of data, a closed testing group should be facilitated, using the Atomic Shocksense sensors for detailed impact recording and more precise knowledge of the impacts the parts have undergone. Within the ramp-up, all parts should be placed into recycling, after their analysis.

Further Developments

Next to the scope within this thesis, the company should focus on sourcing textiles, like soft-liners, etc. from sustainable sources and re-design these for using less different materials (Merino and Polyester — a monstrous hybrid). The focus should lie on functionality and longevity with the possibility of controlled recycling at the part's EoL.

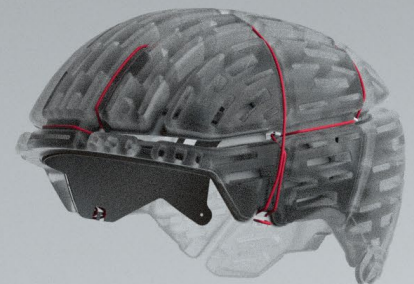
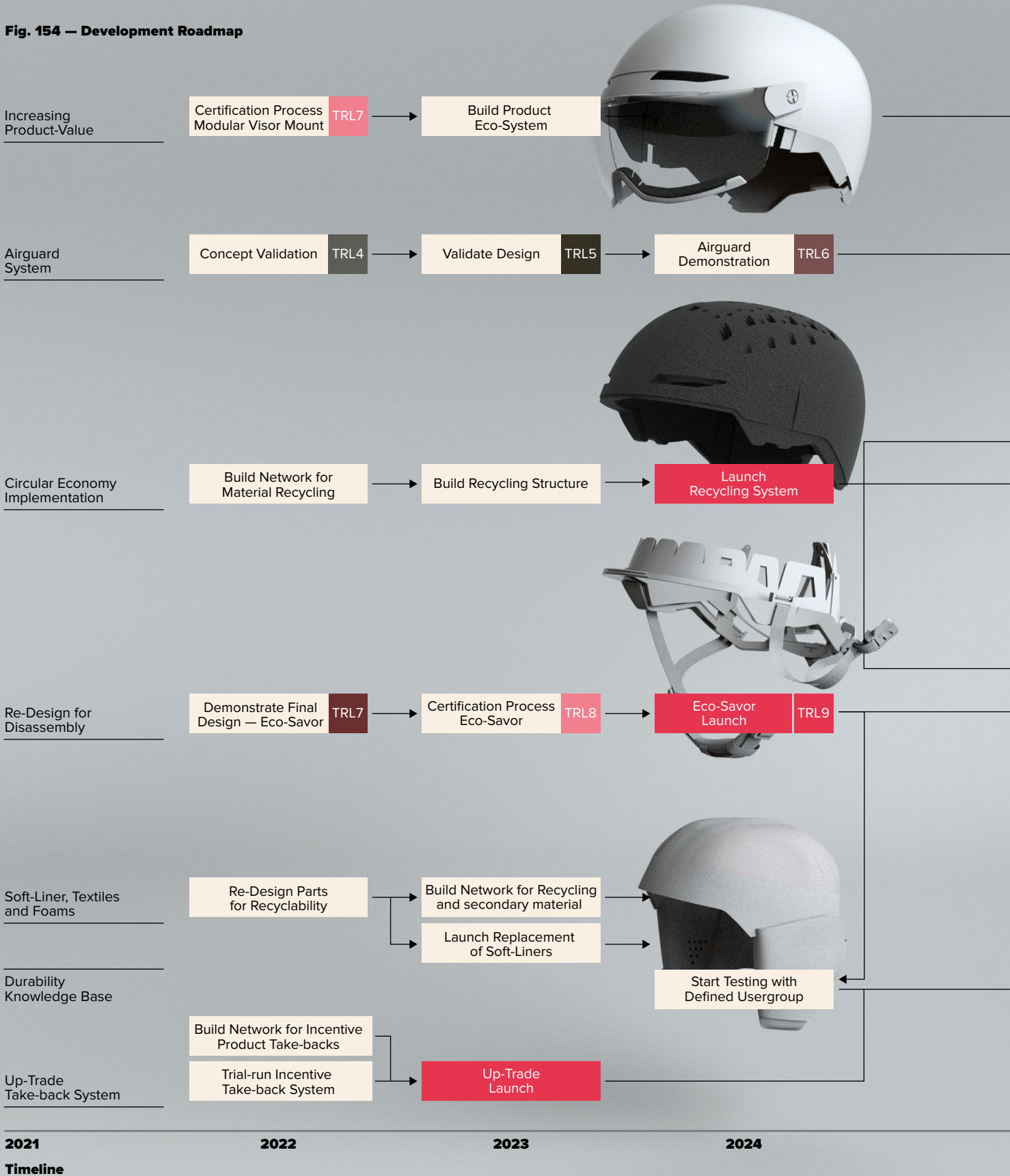

Fig. 153 — Atomic Airguard with Main Concept Parts

The proposal for a sustainable revolution, including multi-impact protection and product remanufacturing

DISCUSSION & CONCLUSION

Fig. 154 — Development Roadmap



ROUTE TO CIRCULARITY

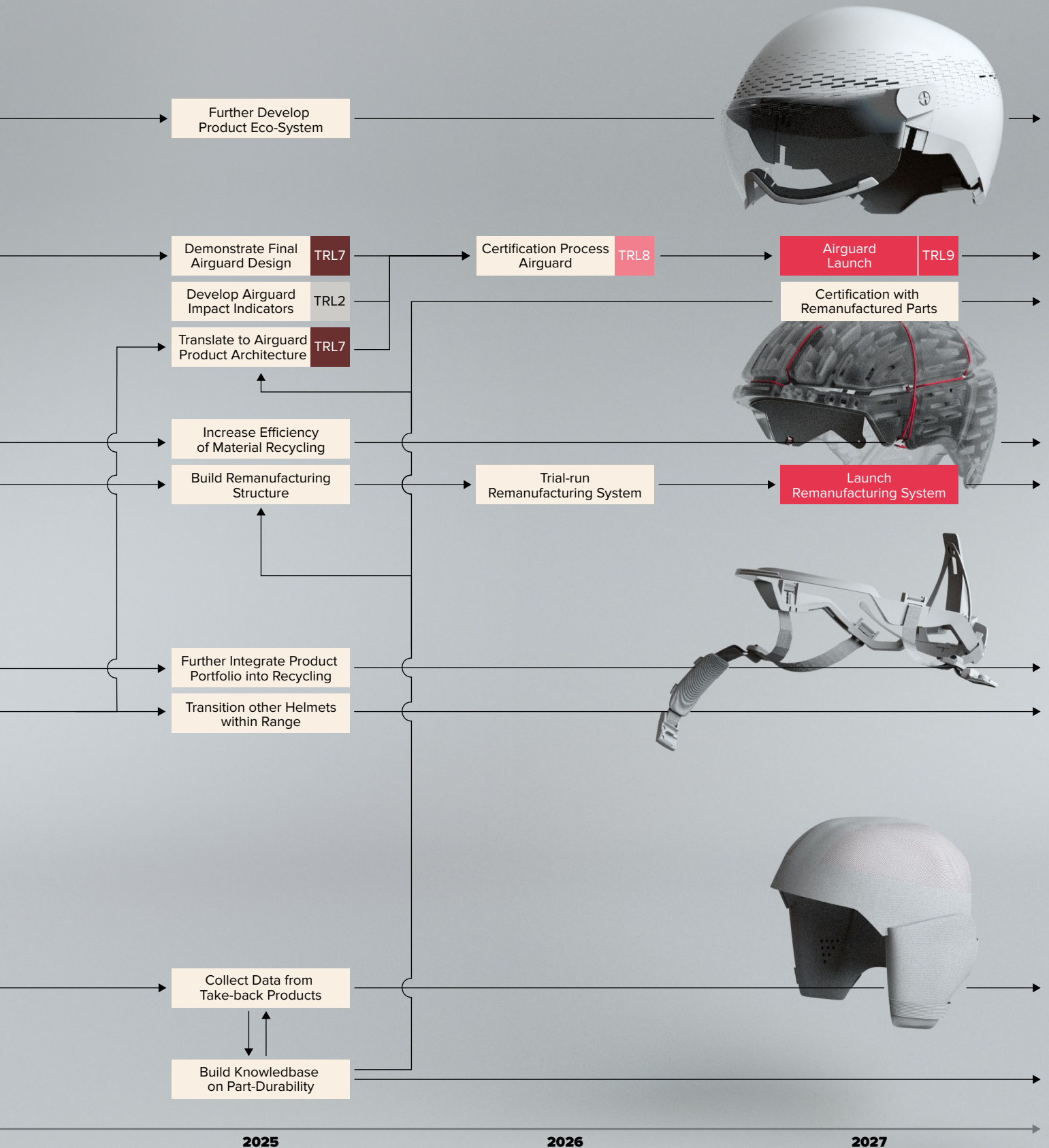

7.3 CONCLUSION

This thesis project was kicked-off with the prospect of investigating general possibilities for sustainability in the product segment of ski-helmets. The horizon of possibilities was broad, from merely replacing materials — decreasing the product's primary impact; doing less bad — to exploring the product's possible entry into the Circular Economy. The Circular Economy is a promising concept, proposing benefits for people, planet and profit. As requirements and wishes on the client-company's side enabled a more visionary approach, the direction towards Circularity was taken.

User Benefits

For the users — the people; the skiers and snowboarders — the proposed solutions can have multiple positive attributes: Multi-impact helmets can make them worry less about replacing a product, as product health will be less prone to deterioration. The TPU-Airguard system can furthermore also provide interesting properties in ergonomics: From more suitable ventilation to a structure that provides improved head-fit, compared to a rigid foam structure. This can also lead to improved, less bulky shapes of helmets; The possibility to upgrade a helmet takes away the pressure of deciding upon one specific functionality — or the need of buying multiple ones. This gives the user flexibility with the possibility to adapt the product to different use-cases; The possibility to retrieve old helmets to receive a discount price can provide an improvement for them and make quality equipment more affordable.

Environmental Impact

The project's focus was sustainability, decreasing helmet's burden on the environment — the planet: Different EoL-scenarios were put into place, including recycling and remanufacturing. Recycling would lead to less and less primary resources used for producing new products. This could prevent resource scarcity and environmental exploitation in regions where primary resources are extracted. Also emissions are decreased, reducing the impact on the atmosphere; Remanufacturing would make a further step and keep resources and energy intact longer; A controlled take-back system prevents plastics from entering the environment, everywhere from landfill to the ocean.

Economic Prospect

The sustainable re-development of ski-helmets can also push the economic competitiveness — and therefore the profit — of the client-company: Proposing a solution for doing good would give them a real advantage compared to companies that currently pursue the approach of mixing cork with EPS to claim eco-friendliness; Transitioning to full disassemblability, recycling and remanufacturing would retain value and therefore assets for the OEM, which then can be re-built into new products, building an advantage above primary sourcing; Disassemblability could also counter production errors and possible product take-backs, as these currently mostly lead to the whole helmet's discarding. This can include small, rarely occurring faulty parts, but also large call-backs because of large-scale production errors. These errors occur, and can lead to large numbers being directly discarded, without the product ever being used. (Fabian Zeidler, 15.02.2021, Appendix C)

Retrieving products could provide a new stream of products for quality inspection and therefore for future improvements in products.





**Fig. 156 — Atomic Airguard
composition**

Recommendations

This thesis project should stand as a vision towards sustainability, and a guiding-line for Atomic to strive for a truly sustainable product portfolio. Two clear steps and the advice on intermediate steps to facilitate both development of products & development of services can be seen as a guideline. It includes the conceptualisation of an innovative form of impact management, which might be a future possibility. However, the technology is still conceptual and further research, testing and design iterations have to be conducted to test its feasibility and bringing this system into reality. The Airguard system can be considered as one option for a more sustainable impact protection system. The time-limitation within this thesis demanded a decision for one direction, yet multiple other directions might be valuable to explore, ideate and test for investigating feasibility and viability.

In parallel to re-thinking the helmet's core, a re-designed product architecture was proposed, enabling a service concept including product take-backs and following processes of recycling and remanufacturing. The product architecture also needs further testing and iterations to proceed towards the market. However, the system is not a closed one — Many detail solutions can enter the current helmet design, until full disassemblability will be reached and also inspire possibilities for upgrading and customization. Again, other options are available to explore: From focusing more on a mono-material structure, possibly including additive manufacturing, to using elements for even faster disassembly, like vacuum-connectors developed by the Agency of Design (2012).

The parts of recycling and remanufacturing rely on a network of interdependent processes to become feasible. As many developments currently focus on building a foundation for sustainability, this becomes ever more important. Strong networks are crucial to the success of the Circular Economy. From production to End-of-Life, from users willing to retrieve products to OEM's willing to take-back their products and facilitate proper care — The Circular Economy relies on the trueness of the circular flows.

The company must aim at becoming trustworthy to their users, in terms of sustainability. Through communicating the clear impact to the customers,

a true outlook on environmental benefits can be given, ensuring users about the positive effects of retrieving their product. This current concept focuses on incentive-based take-backs. However, further options are left to explore. The products could be integrated into a Product-Service-System, with the products staying in the possession of the OEM and clients using them. This can reach a higher level of perceived quality than traditional retail-store rentals, sharing products with many other users. Companies like Swapfiets (2021), a company that rents-out private personal bikes with full service coverage to their users, can be a great example. This would increase customer retention even further.

A similar approach could concentrate on retrieving items in time, to assuring their durability is intact and therefore their usability for product remanufacturing. The approach and methodologies within Design for Managing Obsolescence (Den Hollander, 2018) can be helpful here and service concepts or incentive programs could ensure items are being retrieved at a desired point in time.

Tools used within this thesis, like the Disassembly-maps and the HotSpot-Mapping tool were helpful to collect facts and figures to base the proposed re-design on. These tools are considerably new and should be further tested with different product categories.

DISCUSSION & CONCLUSION

From Micro to Meta Level

Ski-helmets only make one part of Atomic's product ecosystem, with other product categories in place. The principles of the Circular Economy should be further translated into these segments. And as solutions for these are currently not existing, Atomic could develop and own these, with the possibility for driving and transforming a whole market. But sustainability does not end at product level: Atomic and Amer Sports should integrate sustainability into their whole supply chain by using solar power, ensuring environmental health in their processes, promoting water-stewardship and facilitating a process of eco-effectiveness. Factory rooftops can become solar-farms, water-storages, following the sponge-city principle or providing parks and gardens for nearby dwellers, making up for paved soil and lost natural space; Principles like these should inspire the rest of the industry to act more sustainable, protecting the sole base of their business — People being active in an intact natural environment.

Ski-tourism is currently taking ever more intensive directions. Natural environments have to make space for ski-resorts, chalets, hotels and roads to increase the efficiency for tourists and the supply chain caring for them. Artificial snow is used in areas that are ever-more prone to less and less snowfall in the early seasons. This is basically true to the whole Alpine area nowadays.

As a current resort-concept shows, the extent of this categorical overexploitation of the environment summits in the endeavour to blow up entire mountain peaks for the construction of slopes and the connection between ski-areas. Facts and figures within this industry are merely reduced to kilometres of pistes within one resort, numbers of guest-nights spent and the revenue this translates to. In reality, in a business sector that is on the ridge of losing its future proof, the focus should also be put on factors that cannot be categorized in facts and figures easily: Extensive tourism; an intact nature and liveable space for all its dwellers; re-using and maintaining existing infrastructure; responsible usage above consumption, involving products without emotional obsolescence and lastly, the interconnected relationships between social, environmental and economic systems. Until then, the consumption footprint has to be decreased through products designed for sustainability: Kilo by kilo — Helmet by helmet.

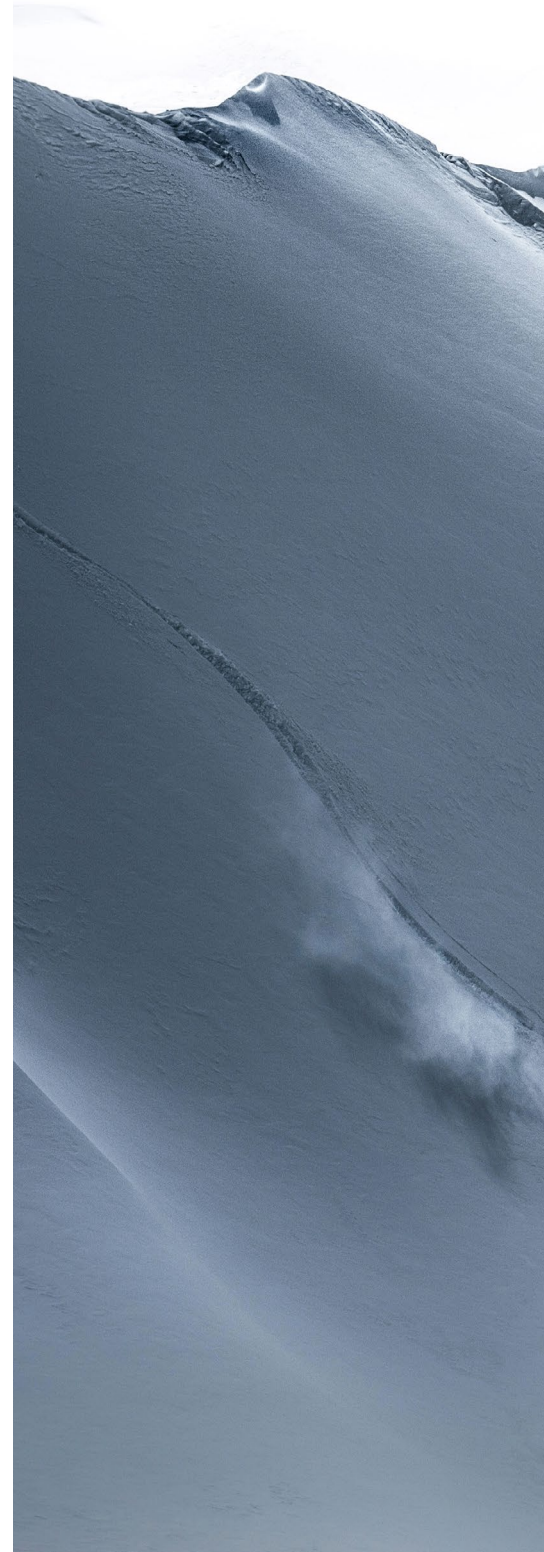







8 REFERENCES & INDEXES



8.1 REFERENCES 190

Bibliography
Internet Sources
Image Sources

8.2 INDEXES 194

Figure Index
Table Index

8.1 REFERENCES

8.3.1 BIBLIOGRAPHY

- Achterberg, E., Hinfelaar, J., Bocken, N. (2016). Master Circular Business with the Value Hill. Retrieved from: <https://www.circle-economy.com/resources/master-circular-business-with-the-value-hill>
- ASTM International (2011). ASTM F 2040 — Standard Specification for Helmets Used for Recreational Snow Sports.
- Bakker, C., den Hollander, M., van Hinte, E., Zijlstra, Y. (2019). Products that Last. (2.0) BIS Publishers, Amsterdam.
- Bakker, C., Balkenende, R. (2020). Bio-based plastics in a circular economy; a product design perspective. Proceedings of the IS4CE2020 Conference of the International Society for the Circular Economy, 6 – 7 July 2020, University of Exeter. [Unreleased Paper]
- Bogerd, P. C., Aerts, J. M., Annaheim, S., Bröde, P., Bruyne, G., Flouris, A. D., Kuklane, K., Mayor, T. S., Rossi, R. M. (2014). A review on ergonomics of headgear: Thermal effects. Retrieved from: <https://reader.elsevier.com/reader/sd/pii/S0169814114001474?token=2BF589DB9F5EE2FD-B7C306F4D1C7F9A84519A379974B0AB-1FD5DA6B7B90875355C90D-4EC555701751D917D3916B816D4>
- Bocken, N. M. P., de Pauw, I., Bakker, C., van der Grinten, B. (2016). Product design and business model strategies for a circular economy. *Journal of Industrial and Production Engineering*, 2016 Vol. 33, No. 5, 308–320. Retrieved from: https://www.researchgate.net/publication/309699661_Product_design_and_business_model_strategies_for_a_circular_economy
- Boothroyd, G., Alting, L. (1992). Design for Assembly and Disassembly. *Design for assembly and disassembly. CIRP annals*, 41(2), 625-636. Retrieved from: <https://www.sciencedirect.com/science/article/pii/S0007850607632491>
- Braungart, M., MacDonough, W. (2002). Cradle to Cradle. München, Piper Taschenbuch; 7. Edition
- CEN/CENELEC (2017). EN 45554 - General methods for the assessment of the ability to repair, reuse and upgrade energy related products.
- CEN/CENELEC (2020). EN 45554: General methods for the assessment of the ability to repair, reuse and upgrade energy related products. European Committee for Electrotechnical Standardization.
- De Fazio, F., Arriola, J. B., Dangal, S., Flipsen, B., Balkenende, R. (2020). Further development of the Disassembly Map, a method to guide product design for disassembly. *Proceedings of Electronics Goes Green 2020+*
- De Fazio, F. (2019). Enhancing Consumer Product Repairability. [master thesis] Retrieved from: <http://resolver.tudelft.nl/uuid:810db9a6-9718-4451-8f8f-67ad0cdccad9>
- Den Hollander, M. (2018). Design for Managing Obsolescence. Retrieved from: <https://www.researchgate.net/publication/326368488>
- European Commission (2012). Ecodesign Your Future. How Ecodesign can help the environment by making products smarter. Retrieved from: <https://op.europa.eu/en/publication-detail/-/publication/4d42d597-4f92-4498-8e1d-857cc157e6db>
- European Committee for Standardization (2007). EN 1077 — Helmets for alpine skiers and snowboarders.
- Flipsen, B., Bakker, C., de Pauw, I. (2020). Hotspot Mapping for product disassembly; a circular product assessment method. *Electronics Goes Green 2020+*
- Flipsen, B. (2020). Hotspot Mapping - User Guide.
- Gennarelli, T. A., Thibault, L. E., Tomei, G., Wiser, R., Graham, D., Adams, J. (1986). Directional Dependence of Axonal Brain Injury due to Centroidal and Non-Centroidal Acceleration. *Proceedings of the 31st Stapp Car Crash Conference, 1987:*

Society of Automotive Engineers, Warrendale, PA. Retrieved from: https://www.jstor.org/stable/44472897?read-now=1&refreqid=excelsior%3A1443672d915dda3e75e0dc716f503f8f&seq=1#page_scan_tab_contents

Granta (2019-1). Polycarbonate (PC).

Granta (2019-2). Acrylonitrile butadiene styrene (ABS).

Granta (2019-3). Polyamides (Nylons, PA)

Jorden, W. (1987). Recyclinggerechte Produktgestaltung als Grundlage für ein optimales Stoffrecycling. *Resources and Conservation*, 14 (1987). Retrieved from: <https://reader.elsevier.com/reader/sd/pii/0166309787900162?token=19E69586E1ADEEB093537B-CA85DE10E54EBB979C036BB8529E1895B706D-C6546B5EEC52417C0745BD1A5FEF0D9BCF012>

Korhonen, J., Honkasalo, A., Seppälä, J. (2017). Circular Economy: The Concept and its Limitations. *Ecological Economics* 143 (2018) 37–46. Retrieved from: https://www.researchgate.net/publication/318385030_Circular_Economy_The_Concept_and_its_Limitations

McIntosh, A. S., Andersen, T. E., Bahr, R., Greenwald, R., Kleiven, S., Turner, M., Varese, M., McCrory, P. (2011). Sports helmets now and in the future. Retrieved from: <https://pubmed.ncbi.nlm.nih.gov/22117017/>

Vermaat, B. (2020). Design for refurbishment of child car seats – Towards circular safety critical products. [master thesis] Retrieved from: <http://resolver.tudelft.nl/uuid:1d77f13b-8005-4cac-aa8d-9350171f158c>

Smulders, M. (2019) TRL — Technology Readiness Level System — an introduction for product design. Delft University of Technology.

Tanaka, S. M., Yamakoshi, T., Tanaka, S., Nogawa, M. (2009). A Novel Hip Protector Material With High Impact Force Attenuation: Leak-Allowed Air Cushion. Retrieved from: <https://www.researchgate.net/publication/224774428>

8.3.2 INTERNET SOURCES

Agency of Design (2012). Design out Waste. Retrieved from: <https://www.agencyofdesign.co.uk/projects/design-out-waste/>

Amer Sports (2021). Circular economy principles. Retrieved from: <https://www.amersports.com/responsibility/environment/circular-economy-principles/>

Atomic (n.d.-1). Inside Atomic Helmets. Retrieved from: <https://shop.atomic.com/en/products/savoramid-visor-hd-an0294.html>

Atomic (n.d.-2). Imprint. Retrieved from: <https://www.atomic.com/en-nl/imprint>

Atomic (2014). Atomic Company [Archive] Retrieved from: <https://web.archive.org/web/20141214144151/http://www.atomic.com/en/Stories/atomiccompany.aspx>

Atomic (2019). Bekenntnis zu Bewusstsein und Engagement für die Umwelt. Retrieved from: <https://www.atomic.com/de-at/article/bekenntnis-zu-bewusstsein-und-engagement-für-die-umwelt>

BBB (2021). GridECO. Retrieved from: https://bbb-cycling.com/de_de/bhe-161eco-grideco

Bollé (2021). Eco-React MIPS. Retrieved from: <https://www.bolle.com/de/cycling-helme/aktivitaten/urban-bike-helme/eco-react-mips-41440.html>

Conservatis (2021). Shock Indicator Omni-GWS. Retrieved from: <https://conservatis.com/en/shipments/shock-indicator-omni-gws->

De Fazio, F. (2020). Further development of the Disassembly Map, a method to guide product design for disassembly. Retrieved from: www.youtube.com/watch?v=cP-GoGNivQQ

De Fazio, F. (2020). Further development of the Disassembly Map, a method to guide product design for disassembly. Retrieved from: www.youtube.com/watch?v=cP-GoGNivQQ

Garcia (n.d.). Tozuda Head Impact Sensor for Concussion Awareness. Retrieved from: <https://www.kickstarter.com/projects/1863807721/tozuda-head-impact-sensor-for-concussion-awareness>

REFERENCES

- Head (2021). Head Radar. Die Helm Revolution ist Jetzt! Retrieved from: https://www.head.com/de_CH/sports/ski/radar
- hexr.com (2020). Our Manufacturing Process. Retrieved from: <https://hexr.com/pages/manufacturing>
- helmets.org (n.d.-1). Helmets: How they Work, and What Standards Do. Retrieved from: <https://helmets.org/general.htm>
- helmets.org (n.d.-2). Bicycle Helmet Buckle Types. Retrieved from: <https://www.helmets.org/buckle-type.htm>
- helmets.org (n.d.-3). Bicycle Helmet Liners: Foam and Other Materials. Retrieved from: <https://helmets.org/liners.htm>
- helmets.org (n.d.-4). How Bicycle Helmets are Made. Retrieved from: <https://helmets.org/how-made.htm>
- helmets.org (n.d.-5). Bicycle Helmets for the 2021 Season. Retrieved from: <https://helmets.org/helmet21.htm>
- helmets.org (n.d.-6). When Should I Replace My Helmet? Retrieved from: <https://helmets.org/replace.htm>
- Koroyd (2020). Landing Page. Retrieved from: <https://koroyd.com>
- Loria, K. (2020). When You Really Need to Replace Your Bike Helmet. Retrieved from: <https://www.consumerreports.org/bike-helmets/when-you-really-need-to-replace-your-bike-helmet/>
- Mips (n.d.). This is how MIPS works. Retrieved from: <https://mipsprotection.com/how-mips-works/>
- Newcomb, T. (2017). How a Bike Helmet protects your head. Retrieved from: <https://www.popular-mechanics.com/technology/a27081/how-bike-helmets-work/>
- O'Neill, E. (2018). When Was the Last Time You Replaced Your Bike Helmet? Retrieved from: <https://www.nytimes.com/wirecutter/blog/when-to-replace-your-bike-helmet/>
- Plastics Today (2020). Low-cost concussion-alert device receives Cool Idea award from Protolabs. Retrieved from: <https://tinyurl.com/7rhaydyw>
- Reuters (2018). China's Anta Sports-led group buying Finland's Amer Sports for \$5.2 billion. Retrieved from: <https://www.reuters.com/article/us-anta-m-a-amer-idUSKBN1O60VR>
- Schutt (2012). Schutt Helmets: TPU Cushioning. Retrieved from: https://www.youtube.com/watch?v=i958_hhiYfQ
- Schutt (2017-1). Schutt Expands Midwest Reconditioning Capabilities. Retrieved from: <https://www.schuttsports.com/news/schutt-partners-with-gridiron-sports-reconditioning>
- Schutt (2017-2). Reconditioning. Retrieved from: <https://www.schuttsports.com/reconditioning>
- Sercalia (2020-a). Omni-GWS. Retrieved from: <https://www.sercalia.com/en/omni-gws-impact-indicator/>
- Sercalia (2020-b). Shockwatch Tube. Retrieved from: <https://www.sercalia.com/en/impact-indicator-shockwatch-tube/>
- Shiffer (2017). Eco-Helmet. Retrieved from: <https://www.ecohelmet.com>
- Smith (2020). Level. Retrieved from: https://www.smithoptics.com/de_AT/helme/nach-kategorie-kaufen/schnee/LEVEL-HELMET.html
- Sonos (2021). Upgrade Programme. Retrieved from: <https://www.sonos.com/en-gb/upgrade>
- Stevenson, J. (2015). ABUS Performance Helmet. Retrieved from: <https://road.cc/content/review/120826-abus-performance-helmet>
- Strategic Sports (n.d.). Biodome. Retrieved from: <https://www.strategicsportsltd.net/biodome>
- Ströbel (2021) Drop-N-Tell. Retrieved from: <https://tinyurl.com/rnz9demk>
- Swapfiets (2021). Landing Page. Retrieved from: <https://swapfiets.de/en/>
- Technavio (2016). Global Ski Equipment Market to Witness Growth Through 2020 Owing to Increasing Initiatives to Popularise the Sport. Retrieved from: <https://www.businesswire.com/news/>

home/20160921005743/en/Global-Ski-Equipment-Market-to-Witness-Growth-Through-2020-Owing-to-Increasing-Initiatives-to-Popularise-the-Sport-Technavio

thingsthatfold.com (2020-1). Helmet Buckles: Side Release versus Magnetic Clip. Retrieved from: <https://thingsthatfold.com/helmet-buckles/>

thingsthatfold.com (2020-2). ABS vs Polycarbonate: Which Helmet Shell Material is Better?

Tozuda (n.d.). Landing Page. Retrieved from: <https://www.tozuda.com>

United States Consumer Product Safety Commission (2017). Which Helmet for Which Activity? Retrieved from: <https://www.cpsc.gov/safety-education/safety-guides/sports-fitness-and-recreation-bicycles/which-helmet-which-activity>

Wavecel (n.d.). Landing page. Retrieved from: <https://wavecel.com>

woom (2021). upCYCLING-Mitgliedschaft. Retrieved from: https://woom.com/de_DE/upcycling-mitgliedschaft

Snow-How (n.d.). Head Rachel Pola Visor white 2019/2020. Retrieved from: <https://snow-how.de/en/ski-equipment/ski-helmets/11182/head-rachel-pola-visor-white-2019/20>

Unsplash (n.d.). Various Photos. Retrieved from: www.unsplash.com

Vale, F. (2017). Diagnose für ein MacBook mit Wasserschaden. Retrieved from: <https://de.ifixit.com/Anleitung/Diagnose+für+ein+MacBook+mit+Wasserschaden/88913>

8.3.3 IMAGE SOURCES

GTI-Gitter (n.d.). Streckmetall. Retrieved from: <https://shop.gti-gitter.at/streckmetall.html>

Pomelo-Sport (n.d.). Giro Aria Spherical Mat White. Retrieved from: <https://www.pomelo-sport.cz/giro-aria-mips-spherical-mat-white-m/>

Pinterest (n.d.-1). Retrieved from: <https://www.pinterest.at/pin/469078117449593907/>

Pinterest (n.d.-2). Retrieved from: <https://www.pinterest.at/pin/469078117449425367/>

Pinterest (n.d.-3). Retrieved from: <https://www.pinterest.at/pin/469078117449385235/>

Pinterest (n.d.-4). Retrieved from: <https://www.pinterest.at/pin/469078117449593910/>

Pinterest (n.d.-5). Retrieved from: <https://www.pinterest.at/pin/469078117449593931/>

8.2 INDEXES

8.2.1 FIGURE INDEX

Fig. 1 — Linear and oblique-impact (McIntosh et al., 2011; own visualisation)	12	Fig. 20 — Key factors for the replacement of helmets	29
Fig. 2 — Schematic of impact-scenario forces (Mills & Gilchrist, 2006; own visualisation)	12	Fig. 21 — User-behaviour at the end-of-use	29
Fig. 3 — Explosion graphic of current Atomic helmets	13	Fig. 22 — Replacement of helmets after a critical impact	30
Fig. 4 — Atomic helmet features	14	Fig. 23 — Current importance of sustainability versus interest in sustainable products	31
Fig. 5 — Different helmet-technologies	16	Fig. 24 — Omni-GWS two-dimensional passive impact sensor (Sercalia, 2020-a)	32
Fig. 6 — EPS- & cork-liner helmet (Bollé, 2021)	18	Fig. 25 — Shockwatch tube mini impact indicator (Sercalia, 2020-b)	32
Fig. 7 — Wavecел technology (Wavecел, n.d.)	18	Fig. 26 — Drop-N-Tell reversible (Ströbel, 2021)	32
Fig. 8 — Folded paper helmet concept (Shiffer, 2017)	18	Fig. 27 — Tozuda head impact sensor for concussion awareness (Plastics Today, 2020)	33
Fig. 9 — ABUS cardboard helmet (Stevenson, 2015)	18	Fig. 28 — Atomic Shocksense active impact sensor	33
Fig. 10 — Atomic ski manufacturing	21	Fig. 29 — Common damages	39
Fig. 11 — Resource flows in the Circular Economy (Bakker & Balkenende, 2020)	23	Fig. 30. — Disassembly Analysis Products	42
Fig. 12 — Conceptual depiction of closing, slowing and shrinking Loops. (discardstudies.com)	23	Fig. 31 — Pull chinstrap through textile strap	44
Fig. 13 — Value Hill within the Linear- & the Circular Economy (Achterberg et al., 2016)	25	Fig. 32 — Remove soft-liner and earpads	44
Fig. 14 — Gender proportion of participants	26	Fig. 33 — Remove fitting-system	44
Fig. 15 — General acceptance of helmets	27	Fig. 34 — Remove inside parts	44
Fig. 16 — Participant age-groups	27	Fig. 35 — Remove chinstrap	45
Fig. 17 — Nationality of participants	27	Fig. 36 — Unscrew goggle-retainer	45
Fig. 18 — Key buying-factors	28	Fig. 37 — Remove top-shell	45
Fig. 19 — Average time-of-use of helmets	29	Fig. 38 — Remove visor	45
		Fig. 39 — Number of different steps	47
		Fig. 40 — Total number of tasks	47

Fig. 41 — Disassembly time	47	Fig. 64 — Number of different materials used	69
Fig. 42 — Number of tools	47	Fig. 65 — Weight proportion of unseparable in-mold liner	69
Fig. 43 — Using a metal spudger to remove BOA-pin	49	Fig. 66 — Number of materials in in-mold liner	69
Fig. 44 — Textile form-fit around fitting-system	49	Fig. 67 — Environmental impact and embodied Energy	70
Fig. 45 — Visor-removal with help of a metal spudger	49	Fig. 68 — Environmental impact and embodied Energy	72
Fig. 46 — Removal of the EPS-disk to remove ventilation	49	Fig. 69 — Destructive snap-fits in the Head Rachel helmet	79
Fig. 47 — Structure and logic of the Disassembly Map	51	Fig. 71 — Destructive snap-fits in the Head Rachel helmet	80
Fig. 48 — Activity and part-priority indicators	52	Fig. 70 — Destructive snap-fits in the Head Rachel helmet	80
Fig. 49 — Chinstrap parts after removal	53	Fig. 72 — Destructive snap-fits in the Head Rachel helmet	82
Fig. 50 — Removing the POC fitting-system	53	Fig. 73 — Concept Strategy	90
Fig. 51 — Fully intact mechanical parts of fitting-system	53	Fig. 74 — Airguard-Concept	94
Fig. 52 — Removing the MIPS-system	53	Fig. 75 — Airguard-Concept with Airguard System Visible	96
Fig. 53 — Remaining in-mold assembly parts	54	Fig. 76 — Airguard Concept with its Single Parts	99
Fig. 54 — In-mold assembly and top-shell parts	54	Fig. 77 — Airguard and Eco-Savor Concepts	101
Fig. 55 — Textiles and soft-paddings in the POC model	54	Fig. 78 — Airguard function schematic	108
Fig. 56 — In-mold assembly and top-shell parts	54	Fig. 79 — The Airguard-system with mounting base	109
Fig. 57 — Disassembly Map Atomic Savor GT AMID Visor	57	Fig. 80 — Airguard Single Parts	110
Fig. 58 — Disassembly Map Head Rachel	59	Fig. 81 — Top and Bottom side of the Flat Airbladder	111
Fig. 59 — Disassembly Map Atomic Savor AMID	61	Fig. 82 — Schutt TPU-Impact management system (Schutt, 2012)	112
Fig. 60 — Disassembly Map Smith Vantage MIPS	63	Fig. 83 — Baseline testing sample of foam-filled air-bladders with orifices (Tanaka et al., 2009)	113
Fig. 61 — POC Fornix SPIN	65		
Fig. 62 — Environmental impact and embodied Energy	67		
Fig. 63 — Carbon-footprint on material level	69		

REFERENCES

Fig. 84 — Impact attenuation of air-bladders with different diameters of orifices	113	Fig. 106 — Cord in idle state	130
Fig. 85 — Impact attenuation of air-bladders with different numbers of orifices	113	Fig. 107 — Cord placed on base ring hook	130
Fig. 86 — Samples prepared for the concept testing	114	Fig. 108 — Sidewards closing element	131
Fig. 87 — Schutt TPU-Impact management system	114	Fig. 109 — Prototyping and testing stages of the Base-Ring	132
Fig. 88 — Accelerations measured in different testing samples	115	Fig. 110 — Side closing elements	133
Fig. 89 — Brainwriting method result	116	Fig. 111 — User access elements Removal of soft liner and the visor	134
Fig. 90 — Alternative energy management	117	Fig. 112 — Earpad-hook mechanism testing	135
Fig. 91 — Air-tech with inside air-bladder	118	Fig. 113 — Visor fixation elements	136
Fig. 92 — Hardshell-Access prototype setup	120	Fig. 114 — Screw counterpart on the shell's inside	137
Fig. 93 — Hardshell access sequence	121	Fig. 115 — Parts included in Recycling Scenario 1	139
Fig. 94 — Hardshell access	121	Fig. 116 — Humidity Sensors within MacBook Pro (Vale, 2017)	140
Fig. 95 — Side closing elements and chinstrap as connecting element	122	Fig. 117 — Parts included in Remanufacturing Scenario 1	141
Fig. 96 — Chinstrap as fixation element (functional test)	123	Fig. 118 — Atomic Uptrade Schematic	143
Fig. 97 — Chinstrap integration Ideation	124	Fig. 119 — Product Eco-System	145
Fig. 98 — Goggle Retainer Fixation	124	Fig. 120 — Number of different parts	147
Fig. 99 — Chinstrap Access	125	Fig. 121 — Number of different steps	147
Fig. 100 — Goggle Retainer	125	Fig. 122 — Total number of tasks	147
Fig. 101 — Structural dome guiding hook	126	Fig. 123 — Number of tools	147
Fig. 102 — Airguard system explosion view	127	Fig. 124 — Tasks needed to remove key parts	148
Fig. 104 — Structural dome, Base-Ring and TPU-cord prototype testing	128	Fig. 125 — Disassembly Map Atomic Airguard	151
Fig. 103 — Airguard fixation and TPU cord development sketches	128	Fig. 126 — Atomic Airguard Product Weight	152
Fig. 105 — Airguard Subassembly	130	Fig. 127 — Atomic Airguard Material Impact	153
		Fig. 128 — Proportions of Weight, Impact and Value	154

9 APPENDIX

CIRCULAR SKI-HELMET — MARTIN STEFFNER

A GRADUATION THESIS BRIEF

IDE Master Graduation

Project team, Procedural checks and personal Project brief

This document contains the agreements made between student and supervisory team about the student's IDE Master Graduation Project. This document can also include the involvement of an external organisation, however, it does not cover any legal employment relationship that the student and the client (might) agree upon. Next to that, this document facilitates the required procedural checks. In this document:

- The student defines the team, what he/she is going to do/deliver and how that will come about.
- SSC E&SA (Shared Service Center, Education & Student Affairs) reports on the student's registration and study progress.
- IDE's Board of Examiners confirms if the student is allowed to start the Graduation Project.

! USE ADOBE ACROBAT READER TO OPEN, EDIT AND SAVE THIS DOCUMENT

Download again and reopen in case you tried other software, such as Preview (Mac) or a webbrowser.

STUDENT DATA & MASTER PROGRAMME

Save this form according the format "IDE Master Graduation Project Brief_familyname_firstname_studentnumber_dd-mm-yyyy". Complete all blue parts of the form and include the approved Project Brief in your Graduation Report as Appendix 1 !



family name Steffner
 initials M given name Martin
 student number 5041236
 street & no. _____
 zipcode & city _____
 country _____
 phone _____
 email _____

Your master programme (only select the options that apply to you):

IDE master(s): IPD Dfl SPD

2nd non-IDE master: _____

individual programme: - - (give date of approval)

honours programme: Honours Programme Master

specialisation / annotation: Medisign

Tech. in Sustainable Design

Entrepreneurship

SUPERVISORY TEAM **

Fill in the required data for the supervisory team members. Please check the instructions on the right !

** chair Bas Flipsen dept. / section: Circular Product Design
 ** mentor Wouter Kets dept. / section: Design Aesthetics
 2nd mentor Peter Wirthenstätter
 organisation: Atomic Austria GmbH
 city: Altenmarkt im Pongau country: Austria

comments
(optional)

⋮

Chair should request the IDE Board of Examiners for approval of a non-IDE mentor, including a motivation letter and c.v.



Second mentor only applies in case the assignment is hosted by an external organisation.



Ensure a heterogeneous team. In case you wish to include two team members from the same section, please explain why.

Procedural Checks - IDE Master Graduation

APPROVAL PROJECT BRIEF

To be filled in by the chair of the supervisory team.

chair Bas Flipsen date 22 - 02 - 2021 signature  _____

Digitally
signed by
Bas Flipsen
Date:
2021.03.04
11:57:03
+01'00'

CHECK STUDY PROGRESS

To be filled in by the SSC E&SA (Shared Service Center, Education & Student Affairs), after approval of the project brief by the Chair. The study progress will be checked for a 2nd time just before the green light meeting.

Master electives no. of EC accumulated in total: _____ EC

Of which, taking the conditional requirements into account, can be part of the exam programme _____ EC

List of electives obtained before the third semester without approval of the BoE

YES all 1st year master courses passed

NO missing 1st year master courses are:

name _____ date ____ - ____ - ____ signature _____

FORMAL APPROVAL GRADUATION PROJECT

To be filled in by the Board of Examiners of IDE TU Delft. Please check the supervisory team and study the parts of the brief marked **. Next, please assess, (dis)approve and sign this Project Brief, by using the criteria below.

- Does the project fit within the (MSc)-programme of the student (taking into account, if described, the activities done next to the obligatory MSc specific courses)?
- Is the level of the project challenging enough for a MSc IDE graduating student?
- Is the project expected to be doable within 100 working days/20 weeks ?
- Does the composition of the supervisory team comply with the regulations and fit the assignment ?

Content: APPROVED NOT APPROVED

Procedure: APPROVED NOT APPROVED

_____ comments

name _____ date ____ - ____ - ____ signature _____

Transitioning Ski-Helmets into the Circular Economy project title

Please state the title of your graduation project (above) and the start date and end date (below). Keep the title compact and simple. Do not use abbreviations. The remainder of this document allows you to define and clarify your graduation project.

start date 08 - 02 - 2021 16 - 07 - 2021 end date

INTRODUCTION **

Please describe, the context of your project, and address the main stakeholders (interests) within this context in a concise yet complete manner. Who are involved, what do they value and how do they currently operate within the given context? What are the main opportunities and limitations you are currently aware of (cultural- and social norms, resources (time, money,...), technology, ...).

Climate change, resource depletion and loss of biodiversity are accelerated by the linear consumption pattern of take-make-waste or cradle to grave. An opposing model of the linear economy is the Circular Economy. It is a systemic approach on keeping products and resources in infinite loops and therefore retain resources and maintain their value.

Atomic is an Austrian manufacturer of skis and related products, including bindings, boots, garments and protective items like goggles and helmets. Ski helmets are a lifesaving companion of the major part of the skiing- and snowboarding population, but are also considered a fashion item to most users. Atomic sells up to 200.000 units annually (2020 numbers), compared to a global annual sales volume of 5 Million.

Ski helmets are currently not designed with focus on the Circular Economy. They consist of multiple different materials assembled in in-mold- or glued-construction. (Figure 1) These integrated assemblies are difficult to separate and unqualified for recycling, sparking the assumption that they are unsustainable. This is further catalyzed by helmets being safety crucial items, which are advised to be replaced after a critical impact scenario. Furthermore, many users consider helmets as fashion items and replace them as they become psychologically obsolete.

As Atomic currently transforms into a business model of 'Sustainable Value Creation', the current conditions are contradictory to these envisioned values.

The unconditional requirements for the safety of the product are the main limitations and a challenge to overcome in re-designing the product to being implemented in the Circular Economy. At the same time, the safety and quality regulations, but also the users desirability to buy and use the product are essential in defining the vision for the re-design of the product.

Another challenge will be to re-design the in-mold product or glued architecture with its many integrated parts. It is defined by industrialization and the focus on safe fixation of elements, cost and production time. Lastly, the integrating element, the EPS foam is industry standard and finding an alternative solution or material for the function of energy management and deceleration in an impact scenario is essential for the re-design.

This project stands as an opportunity for Atomic to create a vision for transitioning their product portfolio towards a circular business model. It would be a novel approach in a sector which is currently defined by unsustainable product design paired with high demands in safety, but also high volume and short lifecycles. It could provide Atomic with a new USP and the possibility to position themselves as a sustainable sporting goods manufacturer. The focus on the Circular Economy, and possibly on repair and refurbishment can also improve Atomic's customer-retention, as this keeps users closer to the brand.

Furthermore, as projects by De Fazio (2019 & 2020) and Vermaat (2020) worked on developing and testing an assessment method for product disassembly, this method can be further tested within this project.

The most important stakeholders are summarized in figure 2.

[space available for images / figures on next page](#)

Personal Project Brief - IDE Master Graduation

introduction (continued): space for images

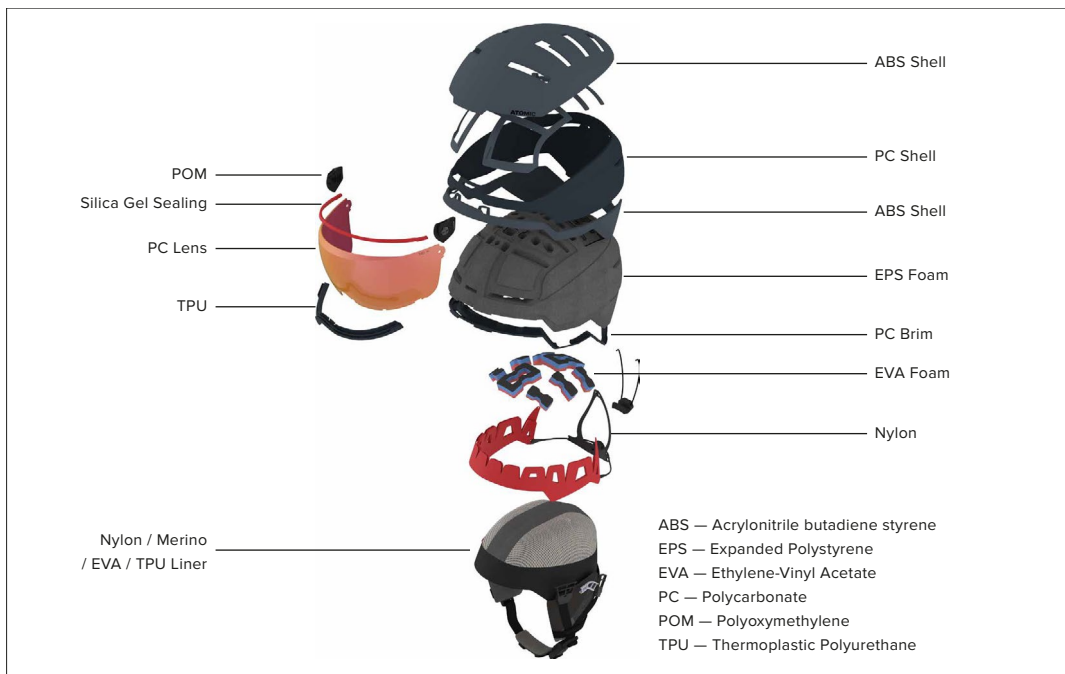

image / figure 1: Explosion Drawing with most common ski helmet materials

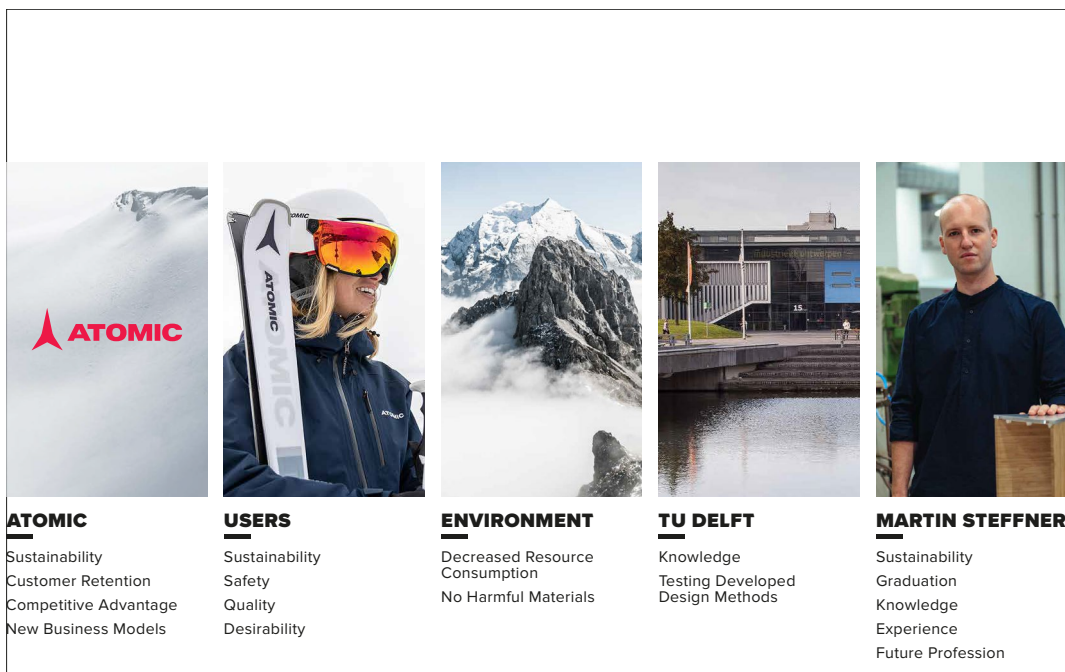

image / figure 2: Main stakeholders and their interests

PROBLEM DEFINITION **

Limit and define the scope and solution space of your project to one that is manageable within one Master Graduation Project of 30 EC (= 20 full time weeks or 100 working days) and clearly indicate what issue(s) should be addressed in this project.

As previously stated, due to the composition of ski-helmets and the materials these inseparable in-mold or glued assemblies contain, they are not suitable for fitting the value flows of the Circular Economy.

Projects by De Fazio (2019 & 2020) and Vermaat (2020) focused on proposing re-design opportunities for specific product categories to fit into the repair- and refurbishment-cycles of the Circular Economy. However, the integration of ski-helmets and related products into these processes still has to be established. Ski-helmets are safety critical, strictly regulated, highly integrated and are prone to short lifecycles, caused by damage or psychological obsolescence.

Therefore, the main question of this graduation project will be:

„Which development aspects need to be considered when embedding highly integrated, safety critical consumer products with short lifecycles into the framework of the Circular Economy and its respectively suitable resource-pathways?“

The scope of this graduation project will be to conduct a case study on ski-helmets. This includes investigating their current ability to fit into the Circular Economy and the needed development aspects to improve or enable this fit. The solution space includes re-designing a representative Atomic ski-helmet to fit into systems of repair, refurbishment, remanufacturing and recycling (e.g.) within the Circular Economy and the adjacent business-model, enabling the product to flow within these cycles.

ASSIGNMENT **

State in 2 or 3 sentences what you are going to research, design, create and / or generate, that will solve (part of) the issue(s) pointed out in "problem definition". Then illustrate this assignment by indicating what kind of solution you expect and / or aim to deliver, for instance: a product, a product-service combination, a strategy illustrated through product or product-service combination ideas, In case of a Specialisation and/or Annotation, make sure the assignment reflects this/these.

The aim of this graduation project is to propose a product re-design for ski-helmets for integration into the business model of the Circular Economy. This includes replacing hazardous materials and re-designing the product architecture for the ease of disassembly, to support repair, refurbishment, remanufacturing & recycling and also envisioning a service-model to facilitate this.

To gain information about the current impact of ski-helmets, a fast track Life Cycle Assessment will be carried out on different makes of ski helmets as benchmarks. A quantitative survey will be conducted to collect more information on usage-time of helmets and consumer habits in using and replacing these products. Next, benchmark products will be assessed using HotSpot Mapping- (Flipsen et al. 2020) and the Disassembly Map-method, including the adjacent research insights and adaptations by De Fazio (2019 & 2020) and Vermaat (2020).

Based on the research-insights, a representative Atomic ski helmet will be re-designed to fit into the Circular Economy. This can include re-designing how crucial functions are provided, the materials used and how all parts are held in place. The solution can also include ways to investigate product health and the definition of the extent in which users are allowed to dis- & re-assemble the product. This proposal will be assessed with the prior mentioned methods for impact and disassembly capability.

Lastly, an envisioned business-model and a roadmap should show how the product fits into processes of the Circular Economy and which development steps and intermediate steps are needed to bring the product to the market in a five year's timeline.

PLANNING AND APPROACH **

Include a Gantt Chart (replace the example below - more examples can be found in Manual 2) that shows the different phases of your project, deliverables you have in mind, meetings, and how you plan to spend your time. Please note that all activities should fit within the given net time of 30 EC = 20 full time weeks or 100 working days, and your planning should include a kick-off meeting, mid-term meeting, green light meeting and graduation ceremony. Illustrate your Gantt Chart by, for instance, explaining your approach, and please indicate periods of part-time activities and/or periods of not spending time on your graduation project, if any, for instance because of holidays or parallel activities.

start date 8 - 2 - 2021

16 - 7 - 2021

end date

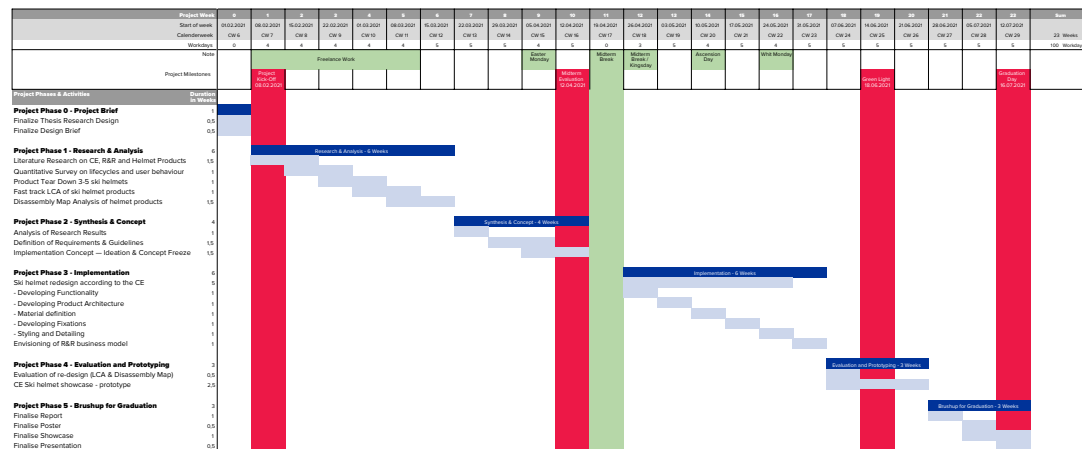

The project is structured in five main phases, with a preparation phase before the project's start. The project will be carried out over the duration of 23 weeks, due to freelance work, holidays and a break-week scheduled for after the midterm evaluation.

List of Abbreviations:

- CE — Circular Economy
- R&R — Repair, Refurbishment, Remanufacturing & Recycling
- LCA — Life Cycle Assessment

Main Project Milestones:

- Kick off meeting — 08.02.2021
- Midterm evaluation — 12.04.2021
- Green light meeting — 18.06.2021
- Presentation & Graduation — 16.07.2021

MOTIVATION AND PERSONAL AMBITIONS

Explain why you set up this project, what competences you want to prove and learn. For example: acquired competences from your MSc programme, the elective semester, extra-curricular activities (etc.) and point out the competences you have yet developed. Optionally, describe which personal learning ambitions you explicitly want to address in this project, on top of the learning objectives of the Graduation Project, such as: in depth knowledge a on specific subject, broadening your competences or experimenting with a specific tool and/or methodology, Stick to no more than five ambitions.

This project is an opportunity for me to consolidate and improve my competences in designing for the Circular Economy and further developing my skills in this area. The expertise in the Circular Economy was my reason to join IPD at TU Delft and I was already able to deepen my skills in this topic at this university. As I enjoyed the course of Advanced Embodiment Design, where we were able to develop a product for easy repair, refurbishment, upgrade and recycling, this project follows a related approach. Yet, until now, my approach in this field was a very intuitive one and therefore I aim at acquiring more proficiency through integrating more relevant methods in my design approach, like the Disassembly Map and the HotSpot mapping tool.

Furthermore, I enjoy developing products that are easy to disassemble. Dealing with glued and in-mold constructions is challenging, but also highly interesting, as it can open new ways for fixations and also to rethink how to provide needed functionality. Also, Atomic is a company in a sector I'm quite familiar with and providing this company with a solution for creating ecologically sustainable products is what I find very exciting. I can envision a career providing consultation on designing products and services to fit into more sustainable business models like the Circular Economy and carrying out my Master Thesis in this topic should be the next step in this pursue.

Sources:

De Fazio, F. (2019). Enhancing Consumer Product Repairability. [master thesis] Retrieved from: <http://resolver.tudelft.nl/uuid:810db9a6-9718-4451-8f8f-67ad0cdccad9>

De Fazio, F. (2020). Further development of the Disassembly Map, a method to guide product design for disassembly. Retrieved from: www.youtube.com/watch?v=cP-GoGNivQQ

Flipsen, S.F.J., Bakker, C., De Pauw, I. (2020) [forthcoming] Hotspot Mapping for product disassembly; a circular product assessment method. Electronics Goes Green 2020.

Vermaat, B. (2020). Design for refurbishment of child car seats – Towards circular safety critical products. Retrieved from: <http://resolver.tudelft.nl/uuid:1d77f13b-8005-4cac-aa8d-9350171f158c>

FINAL COMMENTS

In case your project brief needs final comments, please add any information you think is relevant.



ENGINEERED IN AUSTRIA

NS

ATOMIC

ATOMIC
SIZE ADJUSTER