

# – habitable Ruin

Transformation of Abandoned Roman-Catholic Churches in Post-Colonial Casablanca

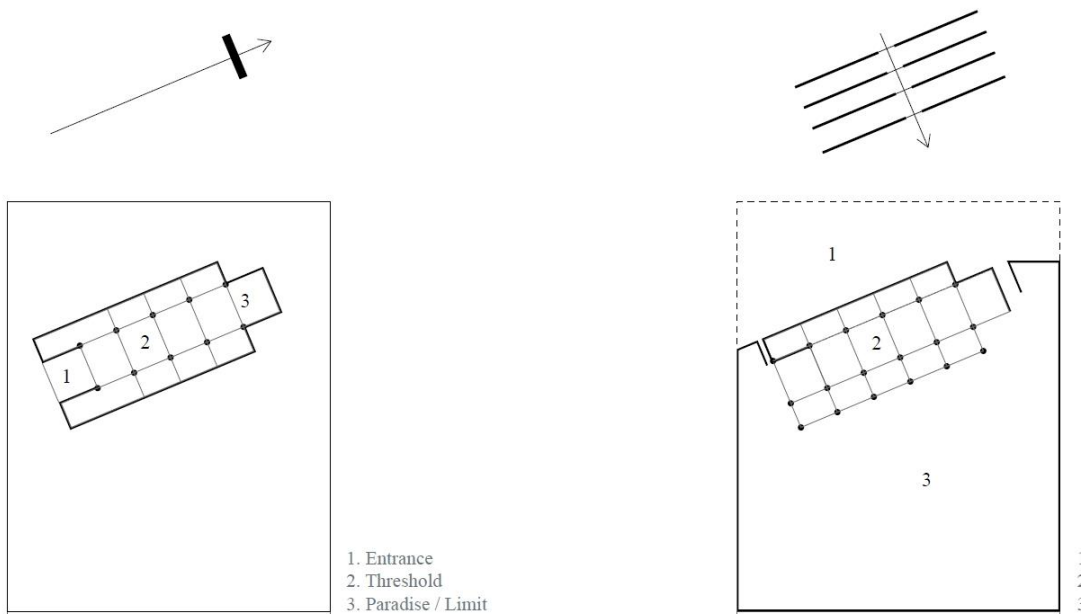

## Contents

I. Shell Without a Soul .....	2
II. Ghost in the Shell.....	6
III. Cutting the Edge Off .....	<b>Error! Bookmark not defined.</b>
IV. Casablancan Church.....	<b>Error! Bookmark not defined.</b>
V. Architect as Manipulator .....	11

## I. Shell Without a Soul

### 1- Post-Colonial Condition and Discontinuities in Urban History

The city of Casablanca can be understood through the consequences of two major shifts happened in its development.

The first shift is the arrival of Europeans who seized the control of the city. During this period of colonization, city expanded rapidly by the influx of both European and Moroccan population. In relation to this expansion, colonial powers decided to contain different cultural groups in separated urban areas.<sup>1</sup> In other words, the city was divided into different cultural fields which provide characteristic urban structures to both control and satisfy the so-called specific needs of each cultural group. As a result, city has been formed as an heterogenous entity which host different realities in its body.<sup>2</sup>

Second shift is the departure of European communities. During this period of decolonization, the culture specific areas and structures become unattended in the absence of the administration that control them. Cultural fields have been re-habited, this time by the same-local population and monocultured. The urban structures which have the capacity to change had been re-appropriated and they got into a transformation process in this new context.

### 2- Steps, Jumps and Pauses in Sequences

In our investigation with Rebekah Tien on transformation of courtyard houses of Casablanca, we realize that they share a common formal structure around which all the alterations had been occurred. We recognize that transformation of an architectural space follows a certain rationality. Moreover, this rationality depends on the mediation between the internal formal structure of architectural space and its external milieu.

According to George Kubler<sup>3</sup> this mediation creates a certain trajectory that every object follows throughout its life. When an object came across with a new situation it adapts to it by changing its shape, and then again and again. This circulation creates differentiated objects scattered all along the spatial temporal surface. However, they all share a common form, since every differentiation is a differentiation of one another. Kubler argues that, because of this continuity, the initial form must always be present in every individual that has been derived from it.<sup>4</sup> In other words, the initial formal structures suggest a certain vector when a thing alters according to situations. George Kubler calls the line, which is drawn by this vector, as “sequence”.<sup>5</sup>

---

*1 It is not usual for foreign administrations to tolerate the local populations in European Colonies. But specific to Casablanca, this strategy was applied by General Hubert Lyautey in order to reduce the future uprisings of local populations.*

*2 There are mainly three cultural two economical division as such; Moroccan High- and Low-Income Neighborhoods, European High- and Low-Income Neighborhoods, and Jewish High- and Low-Income Neighborhoods.*

*3 Kubler, George. The Shape of Time: Remarks on the History of Things. Yale University Press, 2008.*

*4 It is very important for reader to understand, this common form is not ideal, fixed outside of the object. On the contrary; it is very real because it is embedded in the object as a result of material-historical accumulations over time.*

*5 Kubler, George. The Shape of Time: Remarks on the History of Things. Yale University Press, 2008.*

This project argues that there can be three different movements that can happen in a sequence; step, jump and pause.

a- Step

Step is the movement when an object transforms within the limits of its sequence. As we observed in the transformation of Ecochard Grid, even though the configuration of spaces had been changed drastically, the main formal structure<sup>6</sup> stayed the same. We argued that because of this continuity, the family was also able to sustain itself by being able to perform its elemental rituals provided by the organization of the space.<sup>7</sup>

b- Jump

Jump is the movement when the transformation of architectural space happens in-between sequences. As in the transformation of Temple of Athena in Syracuse, the formal structure of temple inverted and became Christian-Basilica formation. The main reason of this formal transformation was to conform to the change in the religious rituals in the society.<sup>8</sup> Therefore, architectural space had to change drastically in character in order to conform to the new cultural-religious context of the society.

c- Pause

But sometimes step or jump does not happen. Then the movement becomes a pause. Pause is when an architectural space does not change even its context changes drastically. When this happens, it becomes dislocated in the new environment and retreats from the effective-programmatic circuits of the city. In other words, it creates morphological and/or programmatically voids in the urban form.<sup>9</sup>

3- Spaces in Waiting

Ignasi-Sola Morales define these spaces as terrain vague.<sup>10</sup> He argues that, these vague spaces are potentially ready to conceive new and unexpected events, precisely because of the absence of their intended use. In this sense, there is space in use based on the appropriation of its affordances to perform a certain task. Space in use always has a name since the intention of the user frames and reduce it to a tool.<sup>11</sup> Yet there is also space in waiting in which the space did not appropriated for a certain use or space does not have a place in the society of built environment. In this sense, space in waiting does not have a

---

6 Courtyard Formation

7 We recognize that courtyard formation provides two main rituals; ritual of gathering and ritual of recession. As you can imagine here the formation of architecture becomes an external transcription that allows the social body to inherit its characteristics to the next generation of individuals. The next generation by repeating the same rituals forms a similar social body.

8 During the 7th century the population of Syracuse changed their religion from Hellenistic Paganism to Christianity.

9 . In Casablanca, these voids can be found as; holes in homogenous territories; as gaps in-between different territories or as islands which cut-off urban spaces from a territory.

10 De Sola-Morales Rubio, Ignasi. "Terrain Vague." *Anyplace*, by Cynthia C. Davidson, Anyone Corp., 1995, pp. 118–123.

11 Remember Heidegger who says that the hammer only comes to existence when it is broken, when it became strange as a result of its dysfunctionality. The question that Heidegger asks is that what remains when an object lost its relations with the social world.

name and therefore it is strange. Meaning that, it is ready to perform unexpected purposes in relation to its own affordances.

#### 4- Church and Its Rigid-Repetitive Shell

These unfunctional, dis-membered urban spaces are common in post-colonial cities like Casablanca due to the violent shifts in its historical development. Roman-Catholic Churches of Casablanca is one of the examples of those dismembered urban spaces.

These religious-public structures lost their initial purpose due to the departure of the community who knew the rituals how to perform them. Thus, they are foreign to the existing urban system since they are not connected to the city in material-physical sense. They were only in relation with the mental part of the city through their symbolic-ritual meanings to the community. Therefore, at the present, they are spaces in waste, physically interior but mentally exterior to the city.<sup>12</sup>

It is not coincidence that they are always locate in the very interior of the city by either located in central positions in homogenous neighborhoods and/or by having a strong connection to the main arteries of the city. It is because they are precisely devised to bring the public together to create a sense of community in their generous spaces.

This generosity and foreignness in form, scale and nature comes from their historical position. Casablancon churches are copied from their European counterparts and imposed on "already grown" existing urban fabrics or on tabula rasas around which later urban fabric accumulated. This top-down implementation of these structures creates walled-off urban spaces with a free-standing form inside, floating without any need of negotiating with their surroundings. In this sense, they repeat the same form independent from their immediate surroundings in different neighborhoods simultaneously.

However, this repetitive common architectural space has a rigid formal structure; meaning that its affordances are only limited to perform very specific religious rituals. This limited affordance comes from the sacred nature of the Roman-Catholic Church Form, which reveals an axis for the orientation of its configuration.<sup>13</sup> The common formal structure of all churches is a unidirectional finite space that is composed of three parts; an entrance, a linear gradual space-threshold and a sudden limit that "cuts" that gradual linearity that would normally go infinity.<sup>14</sup> In other words, this linear directionality is not infinite, but always blocked by a limit, of edge, that opposes to continuous movement.<sup>15</sup>

I argue that this spatial and temporal finiteness is what makes the formal structure of Roman-Catholic Churches too rigid and consistent. Meaning that its form is not capable

---

<sup>12</sup> waste as »matter in the wrong place

<sup>13</sup> When we examine the transformation from Roman Basilica to Christian Church we can see that side walls are closed and the one side that faces to the east is closed with a circular element. This alteration creates a linear direction.

<sup>14</sup> According to Mircea Eliade through that limit it links the Earth to a symbolic Heaven. The impassable limit where body cannot continue is a mental place where, the mind, imagination and the soul reside.

<sup>15</sup> temple (n.1): Commonly referred to PIE root \*tem- "to cut," on notion of "place reserved or cut out" [Watkins], or to root \*temp- "to stretch" [Klein, de Vaan], on notion of "cleared (measured) space in front of an altar" (from PIE root \*ten- "to stretch;" compare temple (n.2)), the notion being perhaps the "stretched" string that marks off the ground. Compare Greek temenos "sacred area around a temple," literally "place cut off," from stem of temnein "to cut."

of accommodating multiple uses which is necessary to make those church lands to be ready for undetermined uses as spaces in waiting in the central areas of the city.<sup>16</sup>

Then the question is how to re-examine and re-signify these rigid-repetitive forms in the changed reality of the city while still retaining their un-programmatic nature? In other words, how to make these ruins inhabitable by operating on their formal structure without designating a certain use? Moreover, how to add another segment to the sequence of church-form so that a typological model can be applied all the churches in order to make them belong to the reality of Casablanca?

---

*16 It is important to understand that the Roman Catholic Church precisely devised to perform the secession from outer world, in order to offer same rituals to revive the same religious experience that can be universalized. When in colonial times, these spaces were able to be a part of the city through these religious rituals embedded in the city's rhythmic functioning. In other words, these forms were able to sustain their place by continuously recalled and reaffirmed. However, with the departure of Christian community, we can argue that these forms do not offer a sustainable affordance in which the undetermined uses can be flourish in the very center of the city as terrain vague.*

## II. Ghost in the Shell

### Casablančan Church

In order to achieve these ambitions church form is re-evaluated by exceeding its physical boundaries. In other words, form understood not as an autonomous individual with clear boundaries.<sup>17</sup> The reason behind this re-position is to find a place for these dislocated artefacts as a social individual together with its milieu. From this analysis a new “local” common form came to life since all the Casablančan Churches share a common characteristic due to their historical position within their milieu as explained in chapter I. Due to its imposed nature, Casablančan Churches always position between the street (visible public realm) and the leftover space surrounded by private urban fabric (invisible urban landscape).

In other words, churches of Casablanca have the capacity to become a threshold due to its position within the built environment.<sup>18</sup>

### Change in Configurational Direction

Within this new situation, project re-defines the church by changing its configurational direction on its side. Since the new form extending the physical borders of the church, the new directional configuration incorporates both sides of its immediate surroundings.<sup>19</sup>

In this new formal structure, the tri-partite configuration of the sacred space is sustained; As church has an entrance, a dark shadowyspace; a long threshold consists of nave and the aisles marked by the repetition of the columns; and an apsis which is a symbolic paradise a place that is not passable. This time entrance or the public is the space between the street and the church; the symbolic paradise becomes a secret garden the space between the private fabric; and the church itself becomes a threshold that re-links those two spaces that are normally separated.

In other words, this time this tripartite configuration has a passable end; a physically reachable paradise that would not be possible in religious-sacred spaces. This new configuration allows a sacred nature but this time it is not religious but secular.

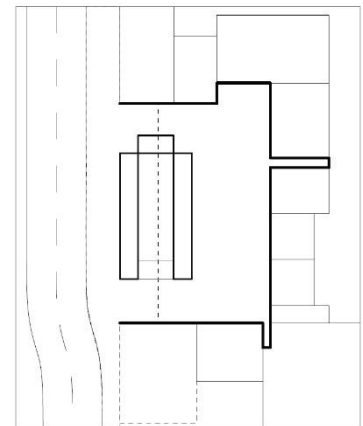
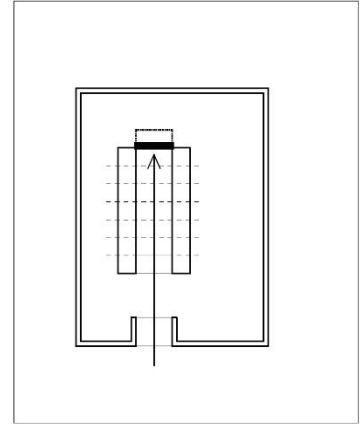

---

<sup>17</sup> There is a difference between optic and haptic perspective. In optic perspective, objects seem to have definite boundaries, as they do not share so much with their environments. However, in haptic perspective where the diffuse between things can be seen more obviously. There is not a clear boundary of an object when one sees them through their smell, heat or sound. This change in perspectives allows us to see objects in gradients, thinner at their edges intertwined with the other edges of other objects.

<sup>18</sup> At this point I decided to position my intervention on a formal level to be able to work on a model that would be able to transform all the church-forms, I reserve the idea of transformation in a more substantial sense, as a major re-configuration of common formal structure, as form understood as a deeper principle than the visible outward look. This decision opens the possibility to intervene on their sequential development with the ambition to add another segment to the family of church-forms that would belong to the reality of Casablanca.

<sup>19</sup> It is important to note that, the main line of intervention is not its configuration or even not its form directly but its configurational logic; the formal structure that what makes is what it is and what make it what it does. In other words, by intervening its formal structure of fixed church to incorporate its constantly changing surroundings a new form emerged but this time this new form does have a loose body.

### III. Surgical Cuts in order to Sur-vive

The radical change in configurational logic pays a way for different consequences in structure, form and shape than the existing sequence of the churches. To, achieve these consequences a common technical method had to be created so that the fixed forms of the Casablancan churches would become able to be altered in spite of their differences between each other.

This technical method is composed of two subtractive-manipulative actions or as I call them “cuts” which operate on the constitutional segmental unit of the linear church form.

#### Vertical and Horizontal Cut

Horizontal Cut or Opening connects the ground floor of the church to its surroundings by cutting off the perimeter walls and erasing the plinth. In a way it creates a continuity on the ground level where public life occurs and exposes hidden perspectives previously blocked by the church.<sup>20</sup> Vertical Cutting or Depression brings a discontinuity to the ground by excavating the structure to its foundations.<sup>21</sup>

As a result of these actions upper-ground part becomes open and outward with lightweight and translucent materials due to nature of skeleton construction. It releases the warm air up and out due to the porosity of construction; and the lower-underground part becomes isolated and inward with heavy and solid materials due to the nature of concrete construction. It stores the colder air and water which are pulled down as a result of gravity.

In short, this differentiation makes those conditions always relatively different from each other. At the same time, one offers an unstable condition open to climatic changes of outside world and the other offers a more stable condition that is unlikely to affect by outside conditions. Because of this sectional manipulation two kind of urban spaces emerges; Plateau and Garden.

#### Plateau<sup>22</sup> and Garden<sup>23</sup>

Plateau is the condition for this space-above, extension of the street, it offers more appropriate space for public activities based on actions, communication and display since it is a space of flows and visibility.

Garden is the condition for the space-below, excavation of the ground, the garden offers more appropriate space for collective activities based on thoughts, contemplation and preparation since it is a space of enclosure and isolation.

---

20 Look for Gordon Matta-Clark. He used his cuts on existing structures to open new perspective that formerly blocked by the solid parts of the structure. In a way Gordon Matta exposes what is hidden in existing structures. Absence of structure is only possible in relation to the presence of the structure.

21 Look for Mary Miss, she excavates the earth. Quite opposite to the voids of Gordon Matta-Clark; in her cuts, absence becomes a closed space in an open field. On ground level, it works as a void a place of mental imagination, inside outside world disappears.

22 Plateau: "elevated tract of relatively level land," ... "flat surface or thing," noun use of adjective plat "flat, stretched out" (12c.) Meaning "stage at which no progress is apparent" is attested from 1897.

23 (Garden): Old English *geard*, Gothic *gards* "enclosure", from PIE root *\*gher-* (1) "to grasp, enclose."

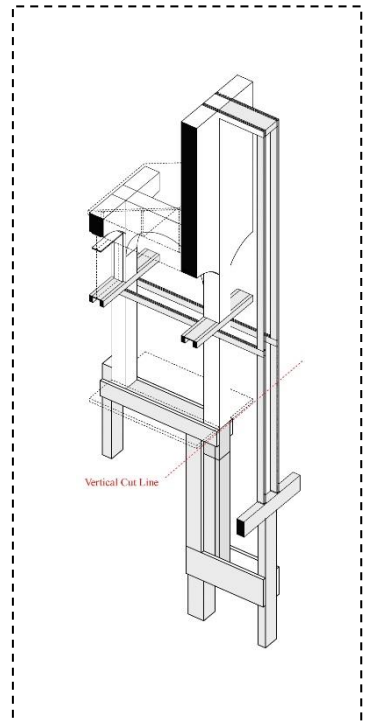
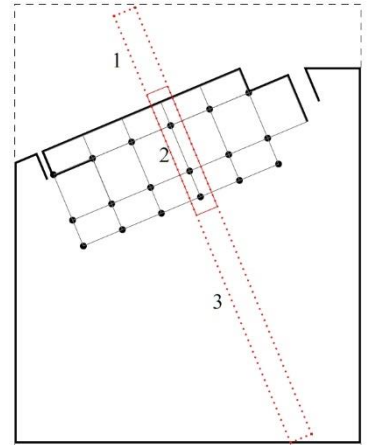

#### IV. Habitable Ruin

##### Loose and Perpetual Alliance of Opposite Parts

The premise of the project is that “life” can perpetually continue through appropriating those two mutually complementary spaces which provides condition for the both sides of the spectrum of social activities.

In this sense, through the application of cuts, a new formal type comes to life. This type is a hybrid of two different forms which can exist without the other. In other words, they are loosely together, they do not need to interact necessarily, they interact occasionally.<sup>24</sup> In this way, each of the parts of the configuration exists autonomously while still having a consistent body.<sup>25</sup>

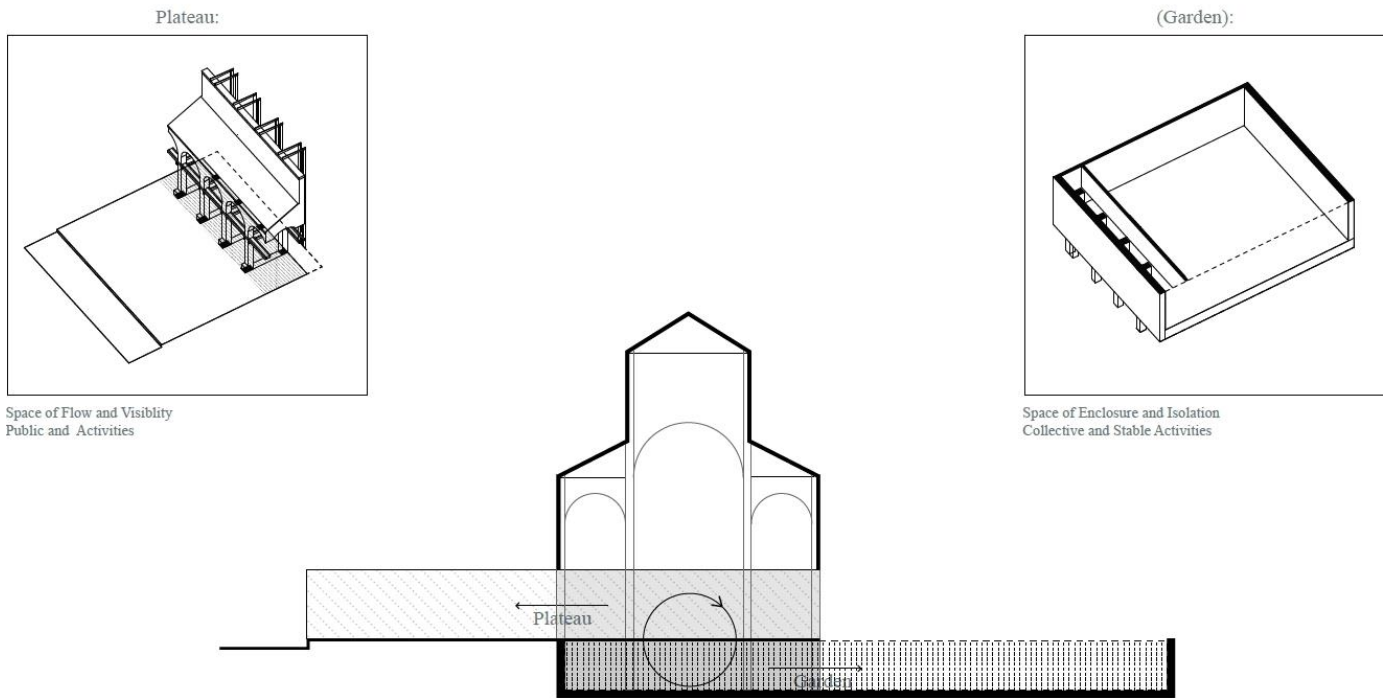

The elements of the garden and the plateau does not have a pre-defined shape or even pre-defined form that could applied to all churches before handed. Even though the formal structure of the church is fixed; its milieu is constantly changing. Therefore, the method based on actions will always create different plateaus and gardens due to the specificity of the situations even though sub-variations shows similar mutations. In other words, these configurative elements and thus the form, appears-enunciates only after manipulative actions applied on the situations.

However, it is still possible to group churches according to their position between the street and the private realm since the new configurational logic of the church position it

<sup>24</sup> Reader can look Graham Harman's *Object-Oriented Ontology* if he/she is curious about occasional interactions.

<sup>25</sup> This part will be extended.



as a threshold between those two realms. In this regard there are three groups of Casablancan Churches. The first group is the churches that lies in between street and the existing fabric linearly. The second group is the ones that position at one corner facing their two sides to the street. And the third group is the ones that lies perpendicularly to the street, facing their 3 side to the public realm.

When Method applied to the specific samples that belong to each group and created three sub-varieties that share the same formal structure.

Application on Group I; Transforms the free-standing church into an inhabitable-supportive wall that separates, connects and supports two urban spaces that consist of three stripes while both ends sustain the circulation. Therefore, the sectional behavior of this sub-variation is stage like.

Application on Group L; From the church form, creates two L shaped surfaces, overlapping only on the apsis side and the rest is spitted with a wall in which both ends circulation occurs. This creates a ribbon like formation in which use, or the organization of the program can be continuous.

Application on Group U; creates two superimposed central spaces one is placed inside the other one. In other words, church becomes the part of its immediate surrounding as a double courtyard element.

As it can be seen, the consequences of the existing churches are completely different from each other. However, all of them offer similar urban spaces and thus common experience for the citizens. The reason of this common experience lies behind the method used in the transformation process. Because method used in transformation process based on the constitutional segment of the church. In bigger scale, in church scale, architectures are totally different whereas in human scale they are all the similar.

In human scale, there are 6 common urban spaces;

- 1- The edge of the church; creates a shadow line whose edge is marked by the existing columns. This niche to the street, extends inside to an indefinite depth since shadow obscure the limits of the space. It offers a deviation from the route, to whom dare to pass.
- 2- Generous Interior of the church; is reachable when one passes the shadow wall, she enters a generous space; reminiscent of the old house of the god. Glare disappears, light becomes softer and homogenous. A continuous platform wraps the always present garden, on which one can see the other and one can be seen by the other.
- 3- Passage becomes visible at only certain point of views. At a certain point a narrow, dark, cold passage descend into darkness. Air gets colder, skin crawls, goose bumps. One has to pass it in order to reach to the garden without knowing what to expect since passage always faces a wall.
- 4- Secret Garden is a place separated from the outside world. In its fully enclosed nature there isn't too much reason to move. It is a place where you have time to recognize the individual faces, your surroundings and details. And along with others sharing the same place. Even when you are alone you are alone with others.

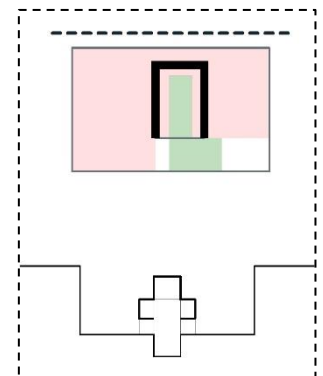
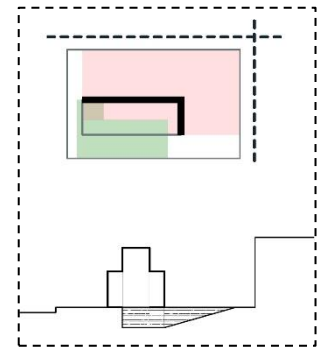
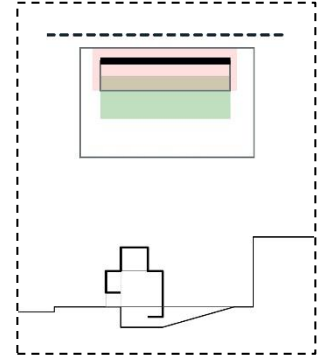

- 5- Void to the sky, is the only space where light seize in. At certain point, when you get bored or because of the light changes drastically you realize that there is an opening, you look up and see a slice of framed sky, real time passes with moving clouds or shimmering stars, as long as you look depth of the space takes you out, even though you are deep inside of the sacred garden.
  
- 6- Slope, then suddenly you realize that; at the edge of the slope and the garden, you are about to leave the space, deep on thoughts ready to continue your everyday habits, with the memory of a slight deviation.

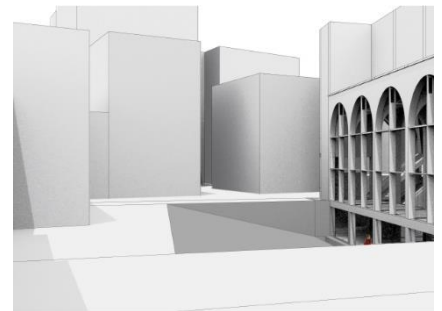
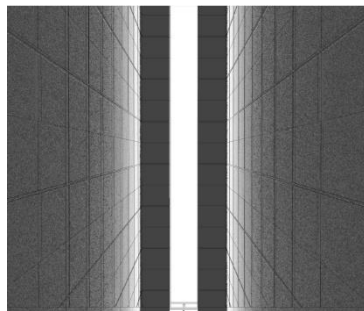
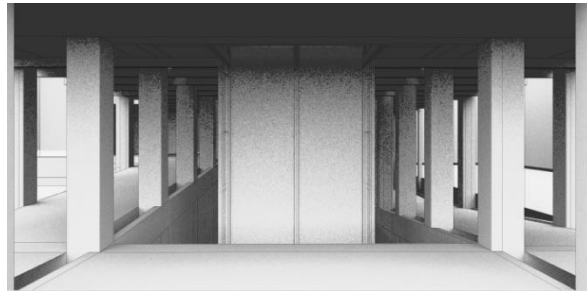
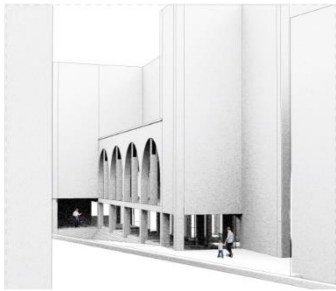

## V. Architect as Manipulator

To sum up, I want to focus on what kind of form, architecture and architect did this process suggested, so that this research can be carried out by exceeding the specific consequences of this particular project.

### Form that per-forms

Architects, no matter what, always operate with form, there is no such thing as formless or informal, every architecture has a certain consistency that separates it from other things. However, then the main question is how to define the form? For example, in this project half of the process was dedicated to the question of what the form of the church is.

Is the church a linear combination of segmental units? Or is the church grouping of different types of spaces. 2 aisles, 2 transepts, 1 entrance and 1 apsis. In these kinds of approaches, the consistent wholistic nature of the church disappeared. Suddenly all the churches have been reduced to the collection of the similar parts which does not show the same attributes with the body that they belong.

Only after I expand my precedents into other churches -from the most primordial ones to the most contemporary ones- I was able to reach the configurational logic that lies behind all the churches. The main formal structure which that directs all the diverse local elements in order to construct the specific church forms. In other words, an underlying motive can be seen in all other churches even though they use different configurational elements or different shapes in order to achieve the same performance. I think when we think architecture through these kinds of formal structures we can exceed the naïve formal (or as I put it sculptural), structural reading or phenomenal readings of spaces which one or another reduces the architecture into their lens by ignoring its other qualities. The qualities that normally organized around the formal structure as I explained above.

In short, my understanding of architectures changed from “what an architecture is composed of” or “what an architecture does to us” to “what does an architecture do to itself? In other words, its own local rationality that heterologically configures different elements belong in specific situations in a certain direction.

### Architecture as Beautiful Ruins

After the recognition, there is two positions that an architect should take, Is he going to operate on the realization of an configurational logic on a specific situation or is he going to operate on the configurational logic of an architecture. These two positions are fundamentally different, the former is about designing a situation for a specific time and space. And thus, it is tactical; meaning that it uses the existing resources to fit them into a model therefore it is more about the projects that is specific to a retain situation. The latter is about designing a long-term base condition on which situations will inhabit later. This approach is strategic; meaning that it uses the existing resources to create a model that would generate different qualities and situations in the long term.<sup>26</sup>

In this project I operated on the base level, which I call ruin, which is what remains after all the contextual changes happened. In that level the specificity of the materials, colors and use lost their relevance since they have high level of changeability. What remains is

---

<sup>26</sup> In metaphors, the first one is about seeing the world through human perspective, and the other is about seeing the world through architectures' perspective.

that, the structure, form, light, position, proportions (or the relation between spaces) and the common experience. Therefore, in my project you can see that three churches are only altered with only elemental and necessary manipulations without specifying any further. They are all designed until the point that they would create a sustainable and beautiful life with the society that surrounds them, after that point I choose to leave it to the unknown.

During this process I become more tend to believe that architect should be able to leave that empty space, by only operating on the level of ruin, so that space would eventually will be filled by the life itself.

The life in space unfolds at the point where the architects know where to stop.

In my project I tried to make those spaces perpetual or forever alive by making them beautiful and purposeful without having any utilitarian concern.

#### Architect that Manipulates

Apart from the specificity of my project, I would like to emphasize the transformation of my role as an architect. During the process, whenever I tried to “impose” additional elements that does not correspond to their formal structure of the church-forms; project stopped progressing. Maybe the most challenging part of the project that the obligation to mediate with a pre-existing structure while still trying to use a configurative method that generate the intended form.<sup>27</sup> I genuinely feel that I encounter with another being, that is able to resist me due to the limitation of my resources and power. In this sense my self perspective had to change from “the architect that constructs as creator” to “the architect that manipulates as an interventionist”.

Even though I worked on a rigid and very specific existing form I believe that this understanding of manipulation can be extended in every situation. Because this approach is not only about transformation in literal sense, but it is about the recognition of a consistent reality that always happen outside of the architect’s vision and control.

Once this formal-realist position is taken, the observation becomes as important as acting, analysis becomes as productive as designing and manipulation becomes as effective as creation.

I believe that these three conclusions are the contribution of my graduation project to the morpho-typological research methodology which I operate in during my graduation thesis. I hope someone would continue this research -in terms of the intervention method that I used- in other transformational processes either it is a newly developed project or of an alteration of an existing architecture.

---

*27 Of course, one can argue that every architect works within a given condition but for my process I think, it was different due to extreme rigidity and the differentiation of existing church-structures.*