

PROJECT
H U M A M
 MESUT ULKU

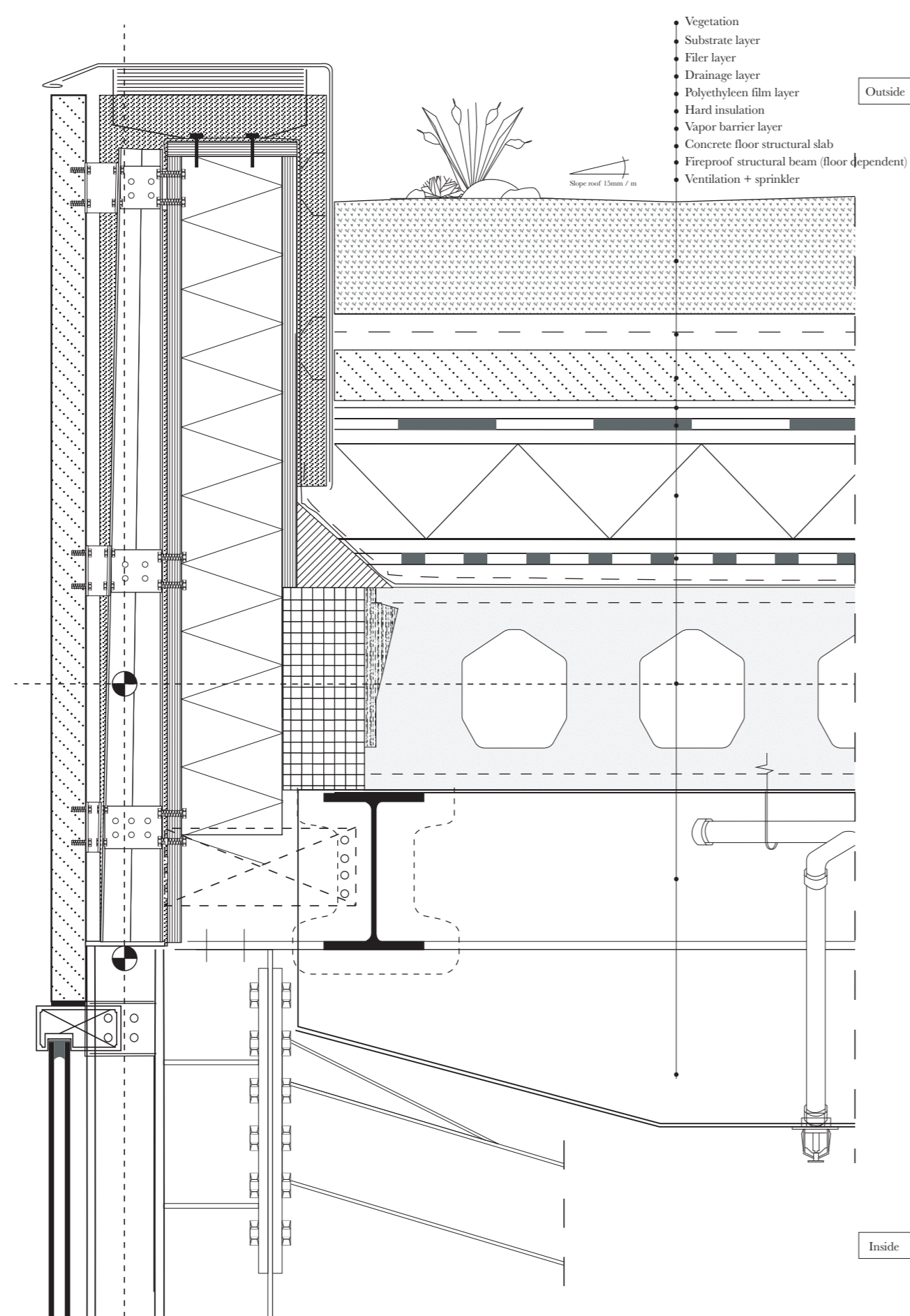

BABY HUB

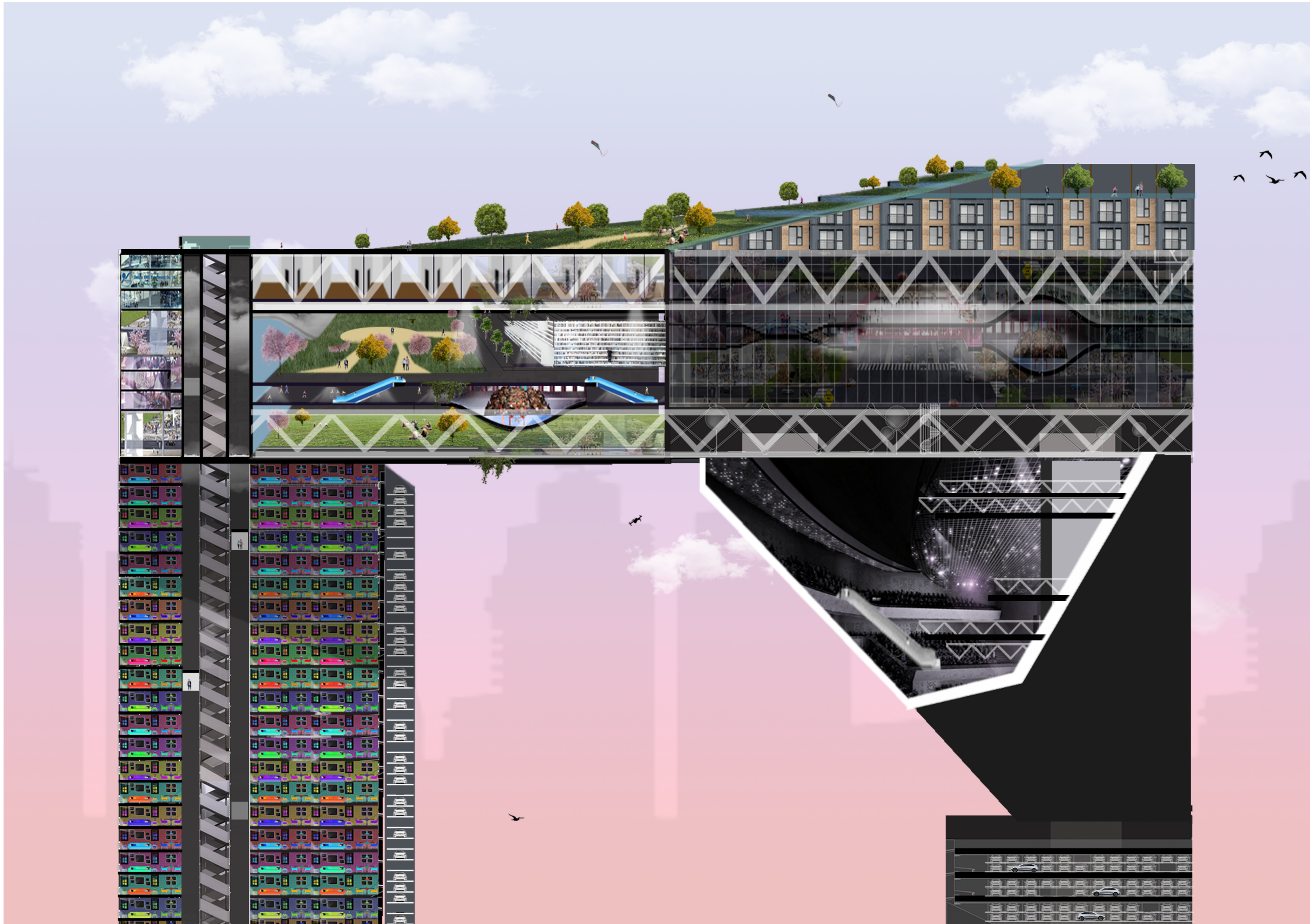
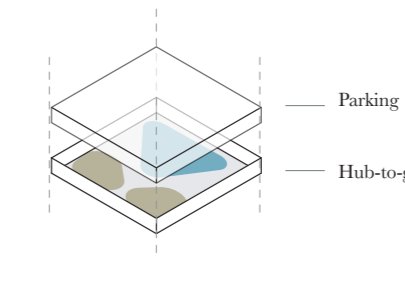
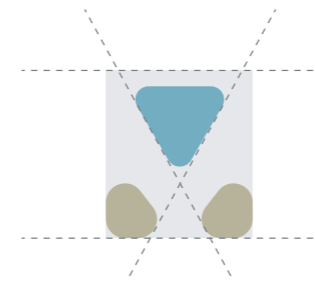

CITY HUB

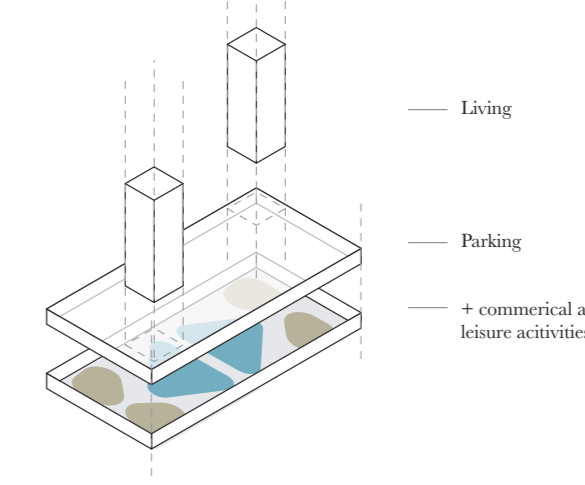
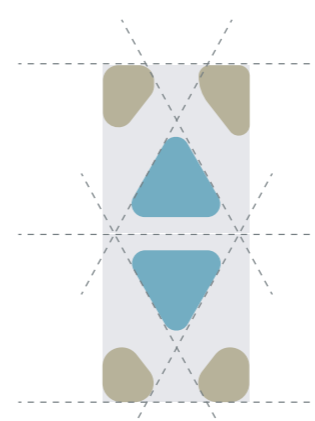

MOTHERSHIP HUB

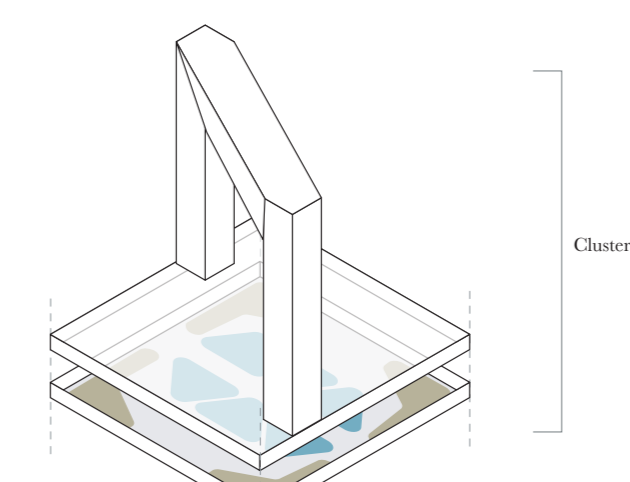
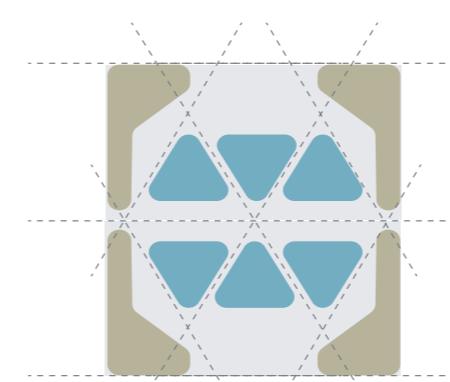

PROJECT
H U M A M
MESUT ULKU

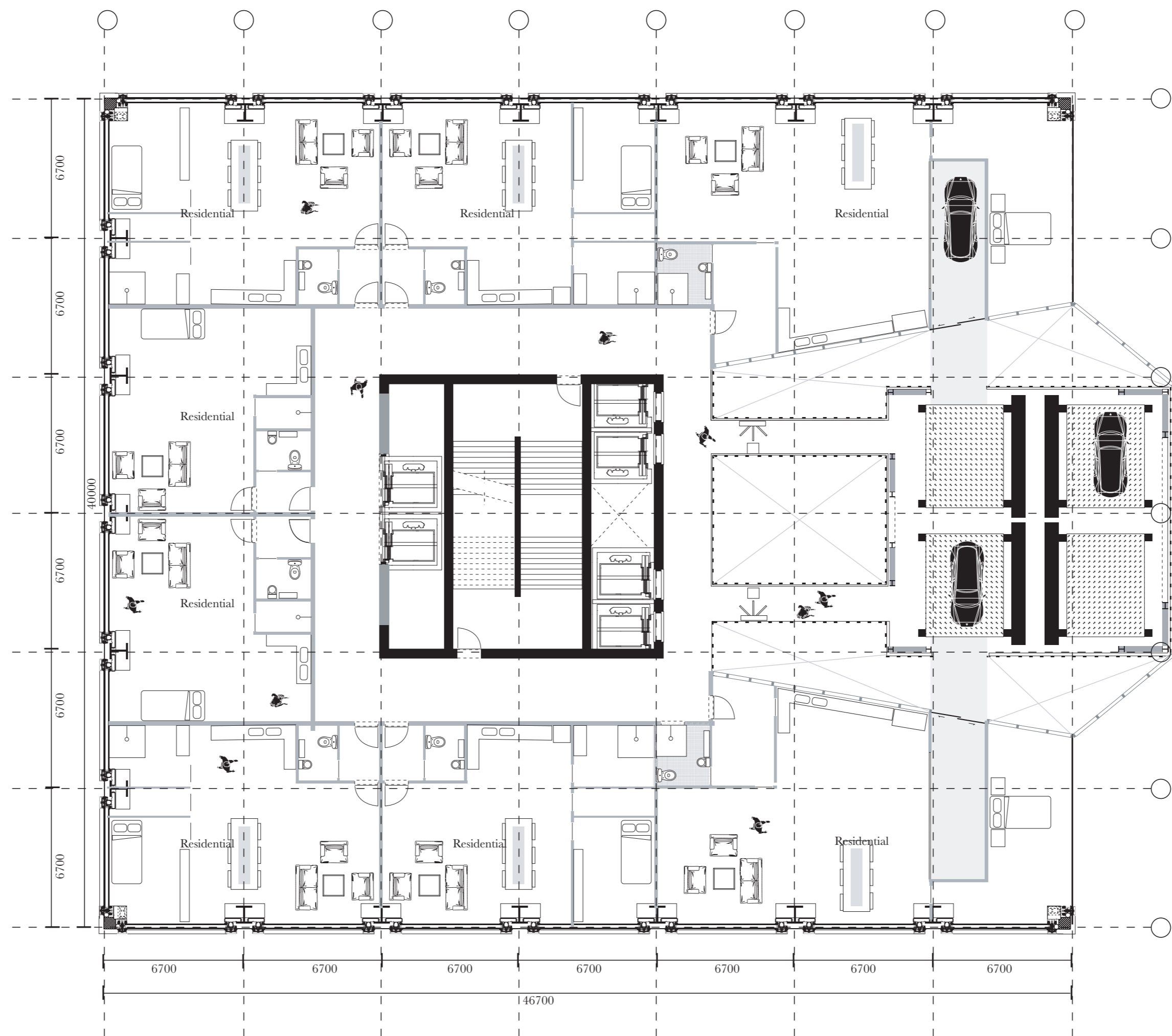
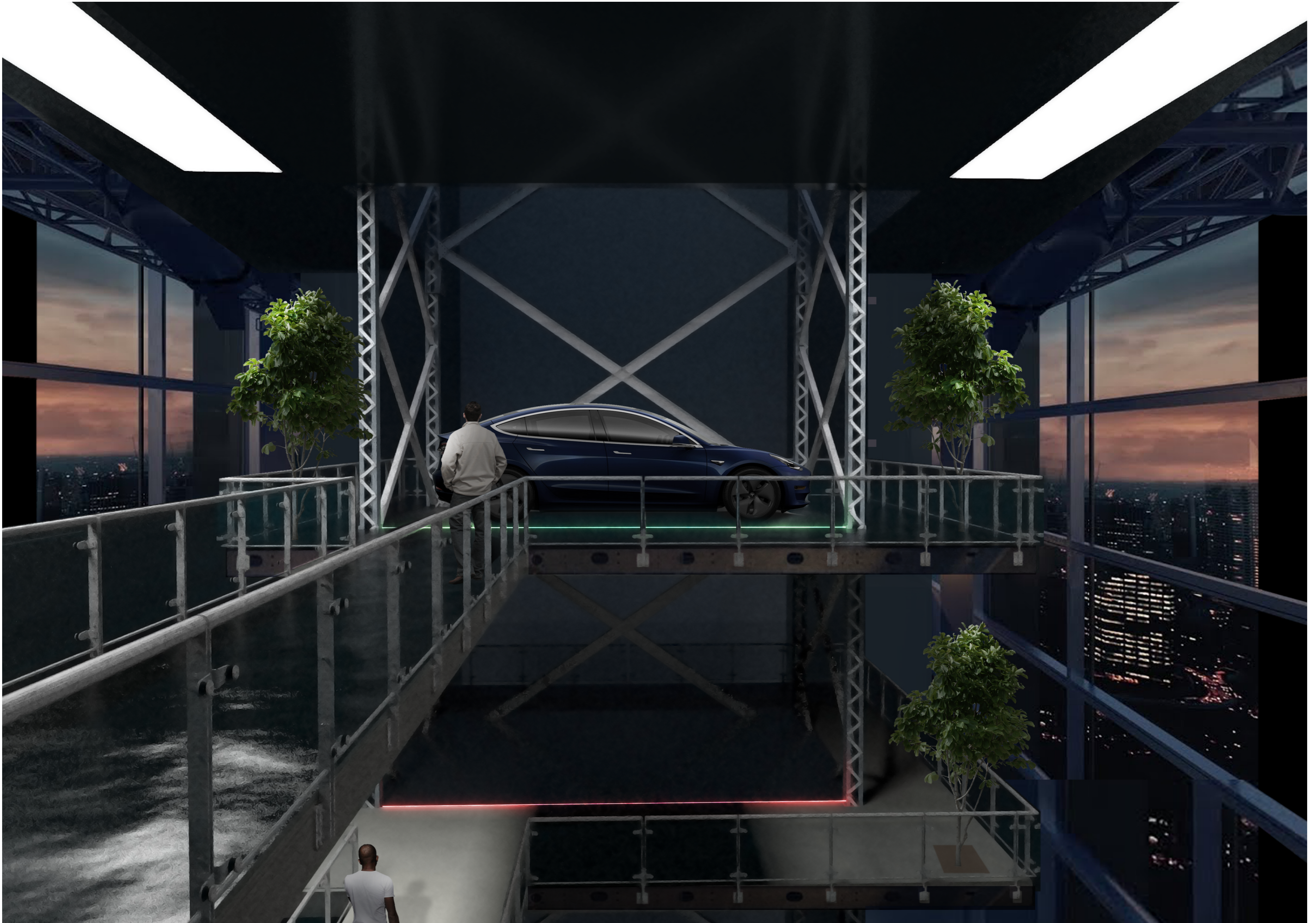

PROJECT
H U M A M
 MESUT ULKU

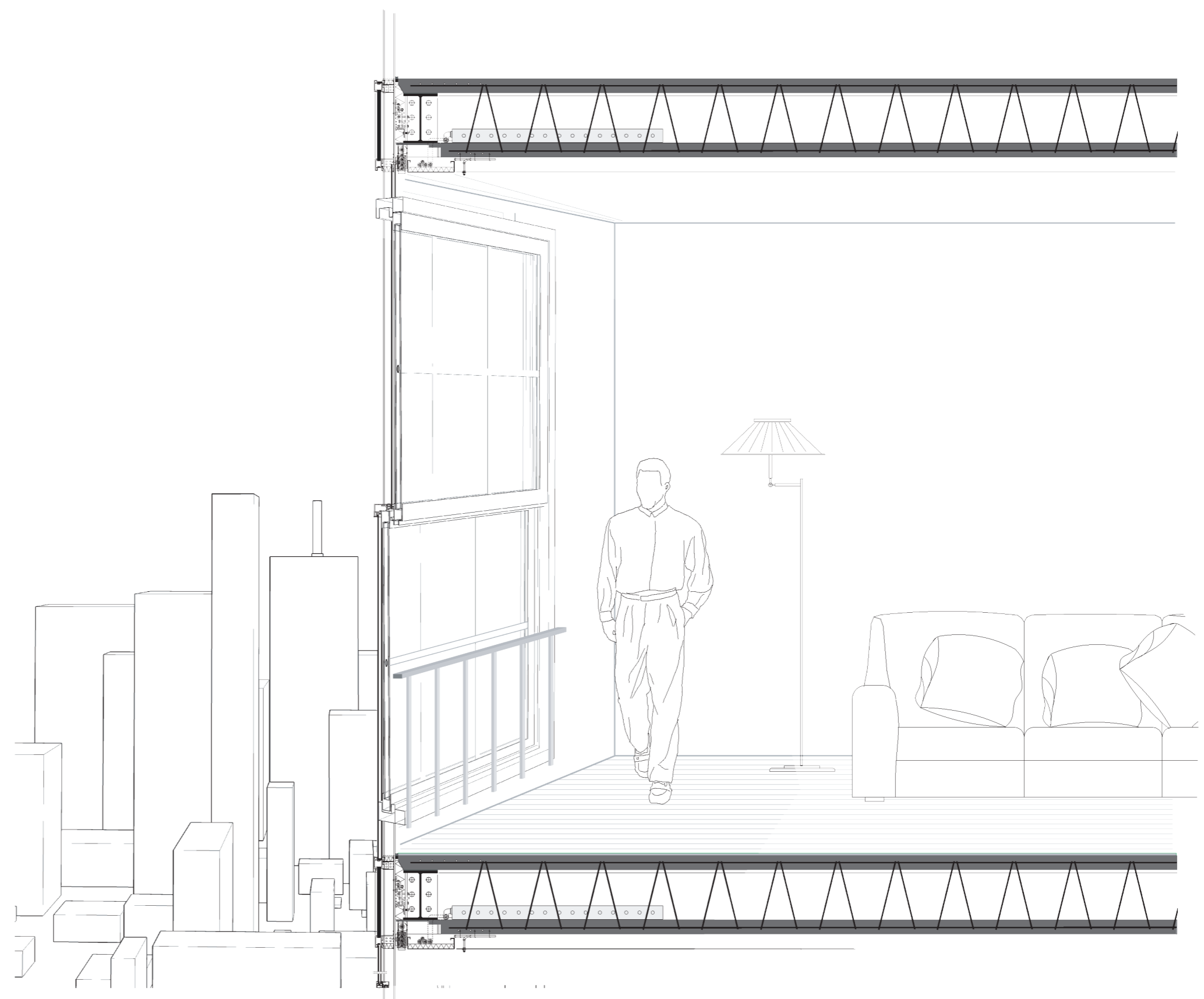
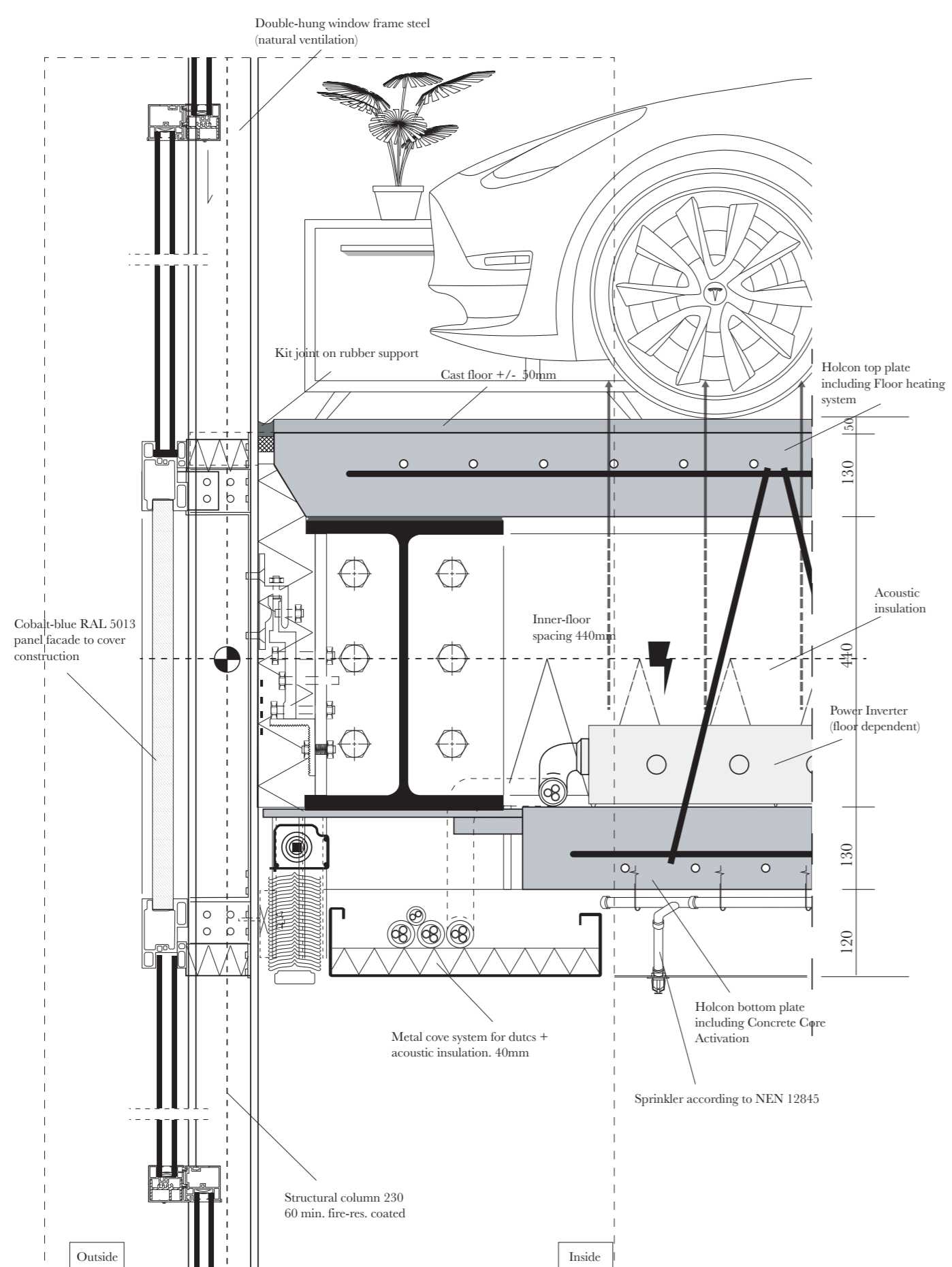
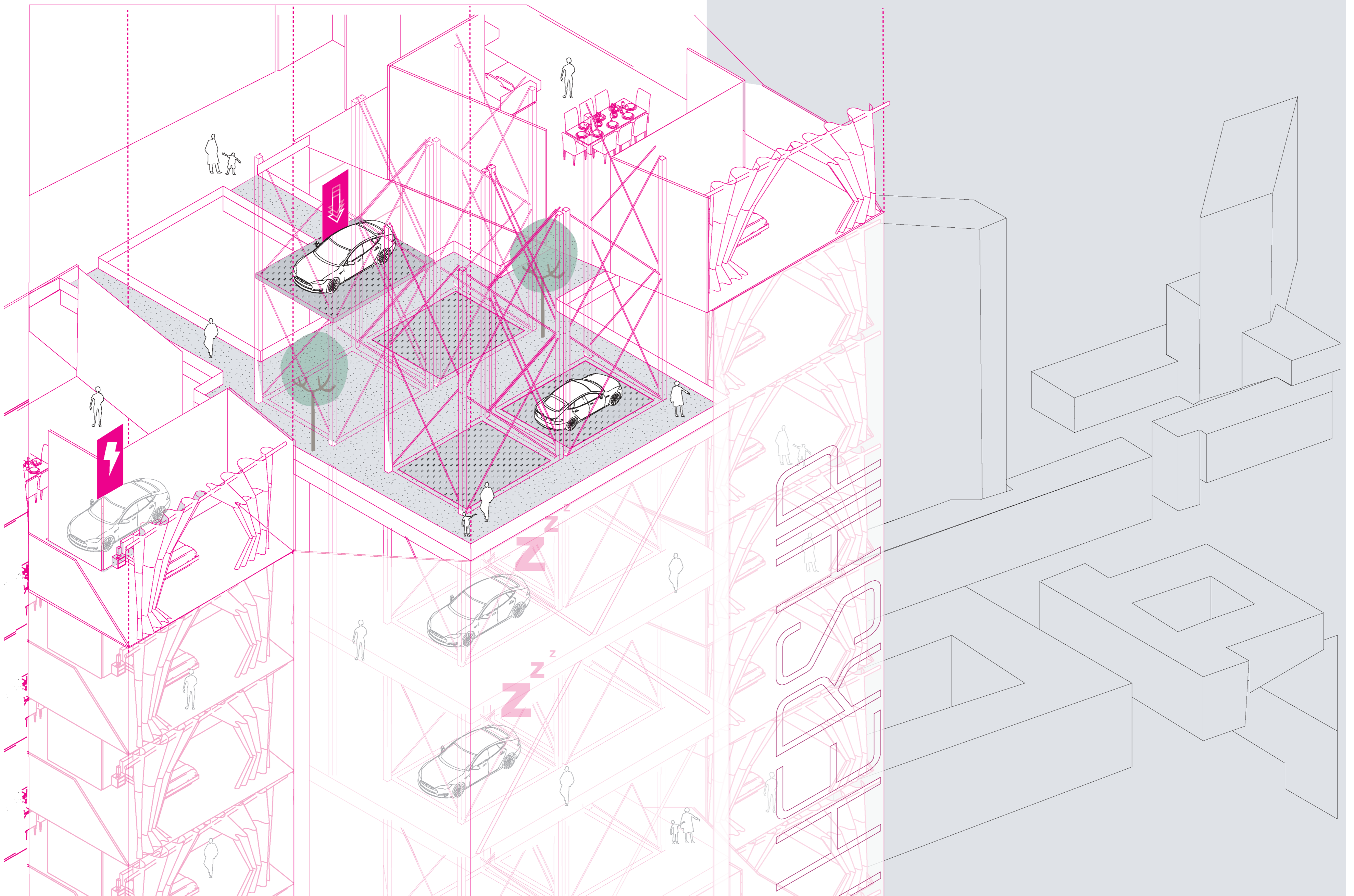

PROJECT
H U M A M
MESUT ULKU

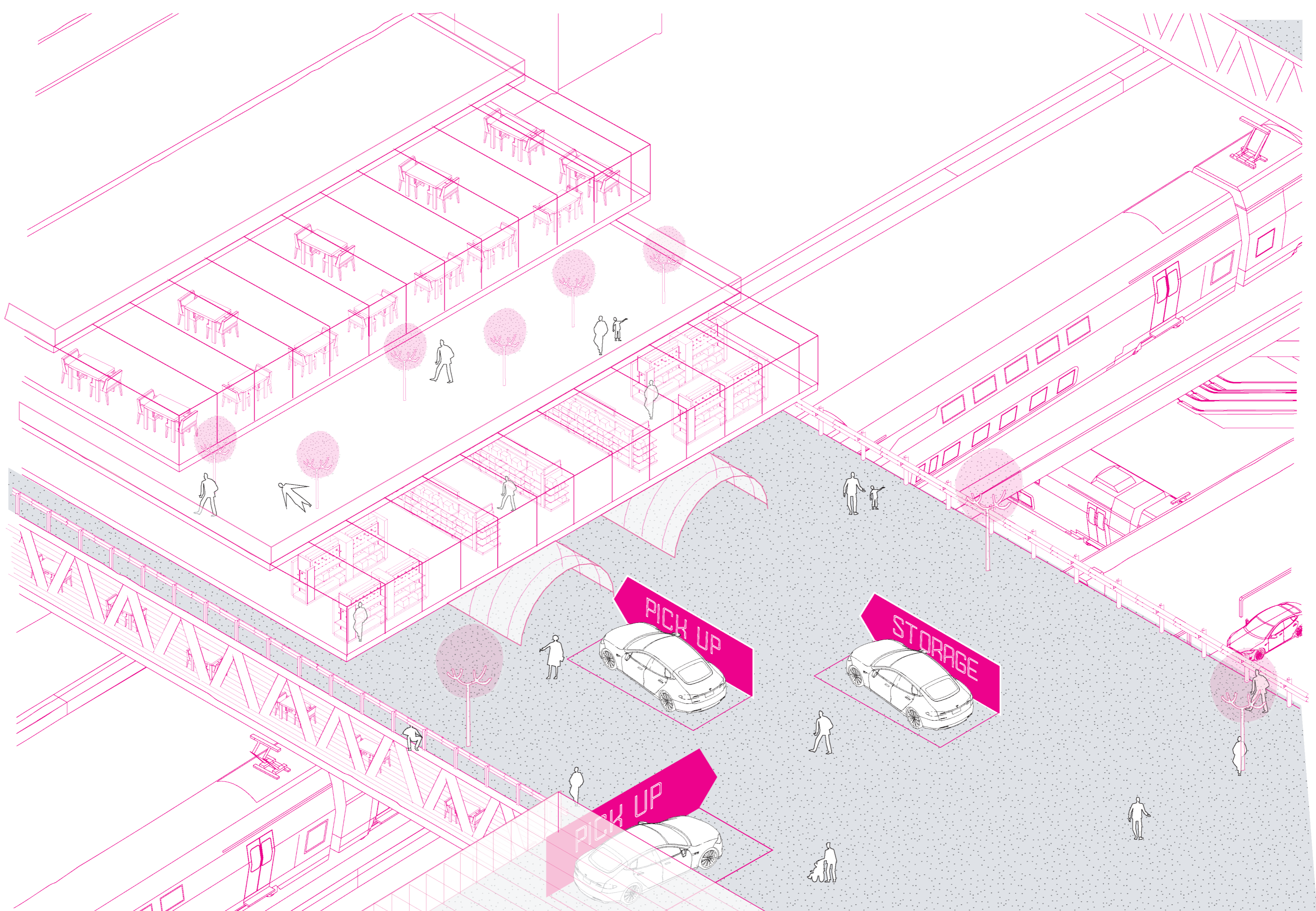
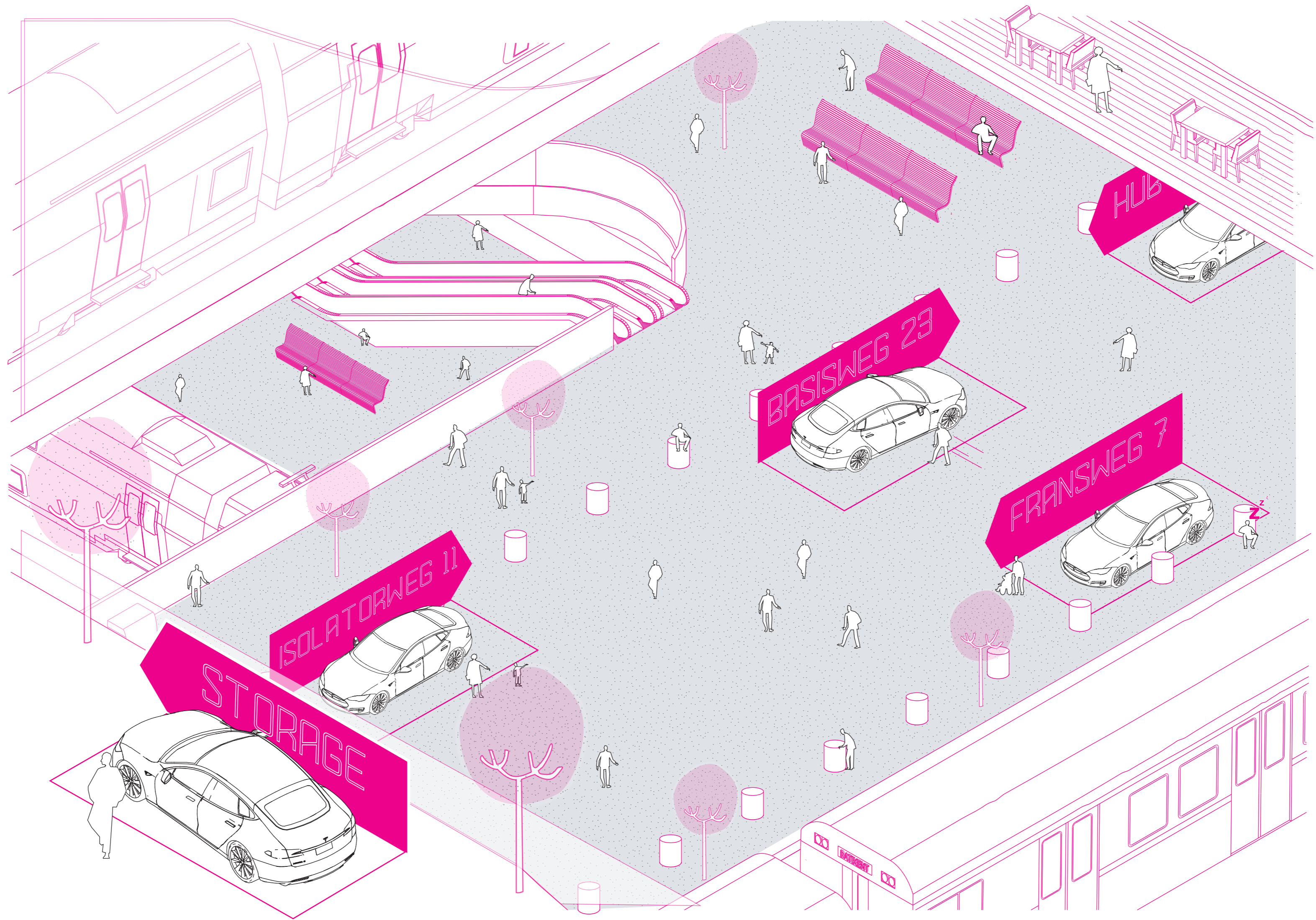

PROJECT
HUMAM
MESUT ULKU

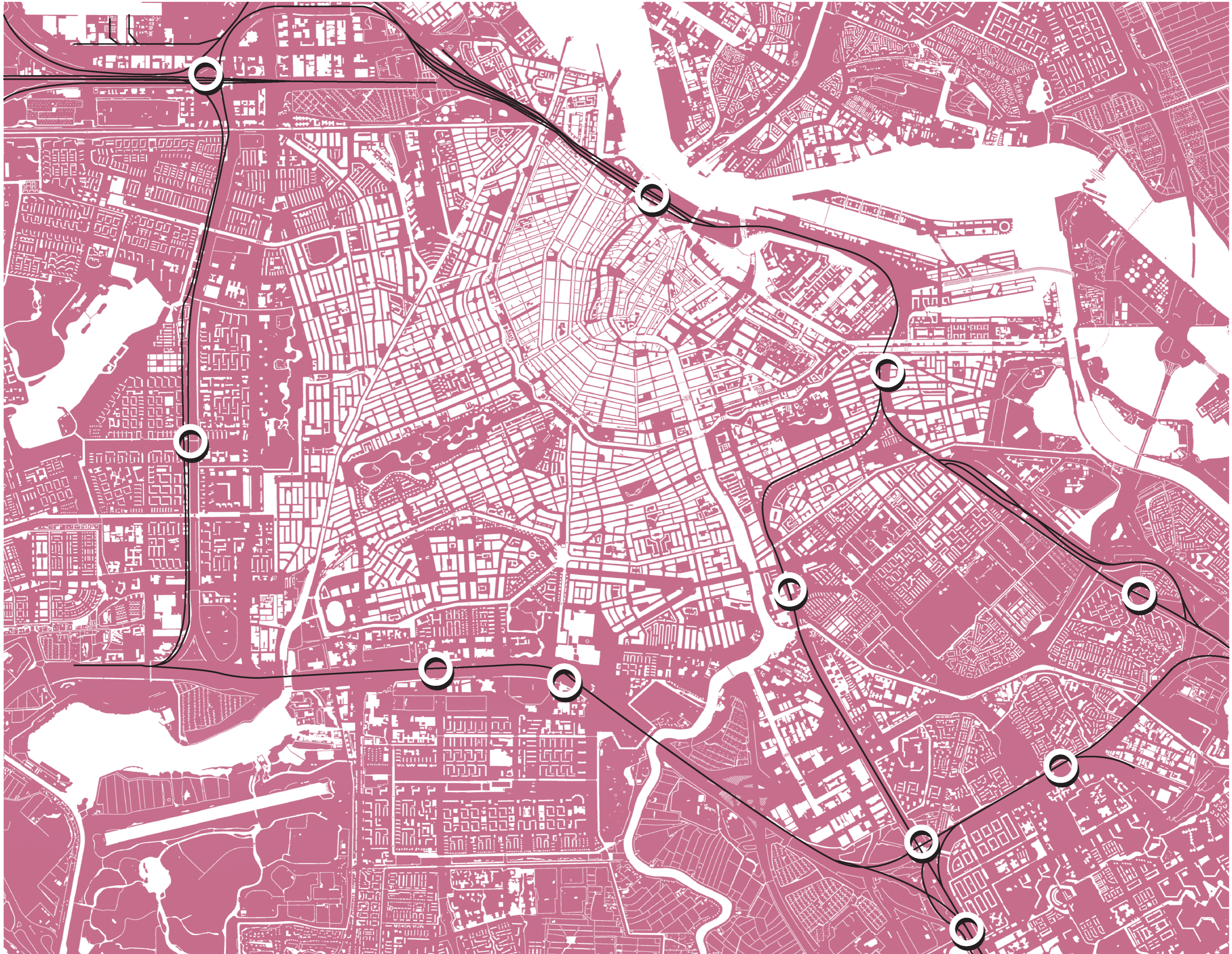

This project is the result of my research for the graduation project of Project HUMAM; Hub for Urban Mobility for the Amsterdam Metropolitan area. The project focuses on the future demands of the Amsterdam Municipality in which they expect an increase of 70.000 new households and 50.000 new working areas over the coming 30 - 40 years in Havenstad area.

More people are moving from their village to the city or the suburbs, creating a full expanse of the city boundary and less space to accommodate the residents. However, the Municipality acknowledge the fact that this growth also brings difficulty in the accommodation of the expected households. Amsterdam Havenstad has been chosen to be the new urban core for these developments. The area is well-known for its extensive industries and enterprises, making this area rich and profound for the economic heart of the city, which will make its shift towards a mixed-use region for industry and residents. To accomo-

date these amount of people, the Municipality sees new opportunities in technological innovations and sees the use of a car as a potential problem in terms of land-use and health.

Therefore, project HUMAM will analyse and research the Sloterdijk area, to accommodate a transportation hub for the city. This hub enables the district to ban the car and put the focus on Automated Vehicles and shared possibilities. To keep Sloterdijk connected, the hub will perform as the catalyst for the area. This project tries to posit a vision of a future where anyone in the city can go wherever they want, whenever they want to, and accordingly, a place where we share our spaces in total connectivity with our mechanic neighbours.

Project HUMAM will be the landmark of innovation and offers solutions to this growing problem.

“Something great is coming.”

PROJECT
H U M A M
 MESUT ULKU

F R E E D O M



E X P E R I E N C E

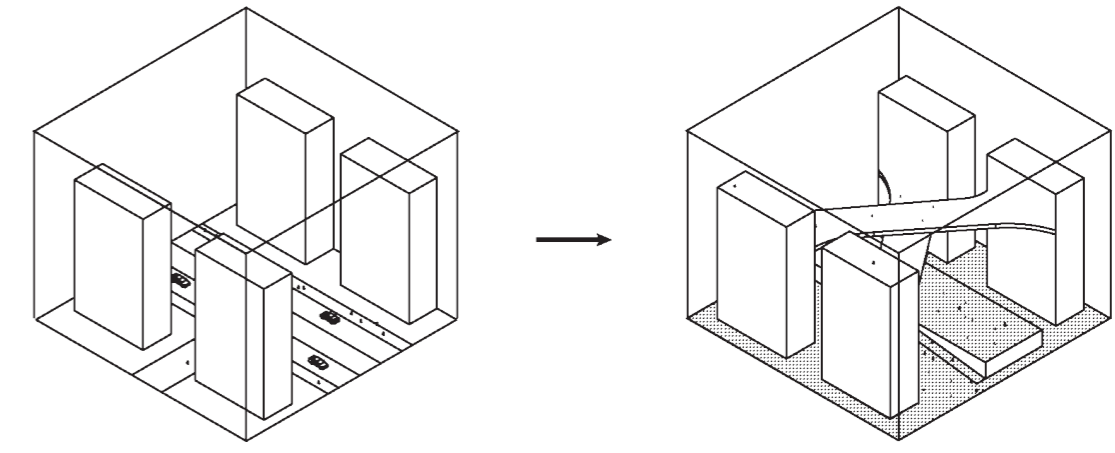
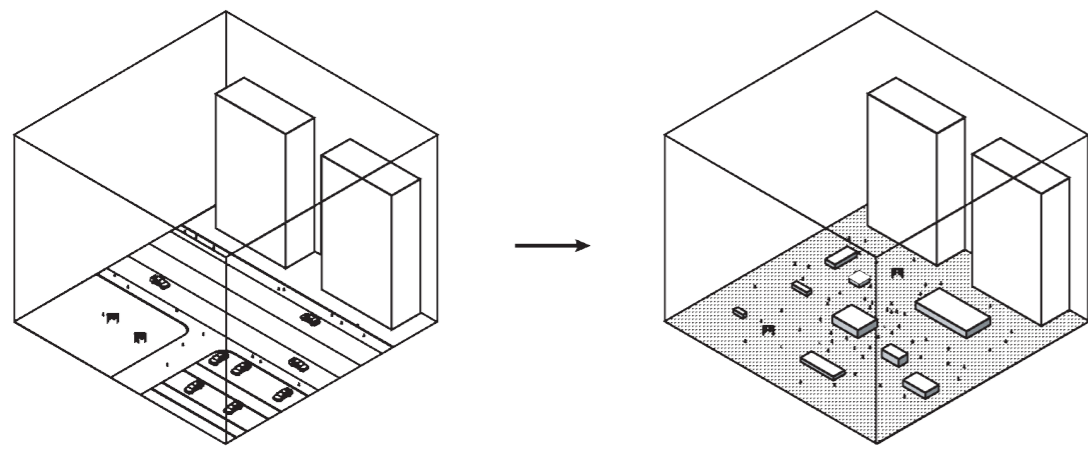
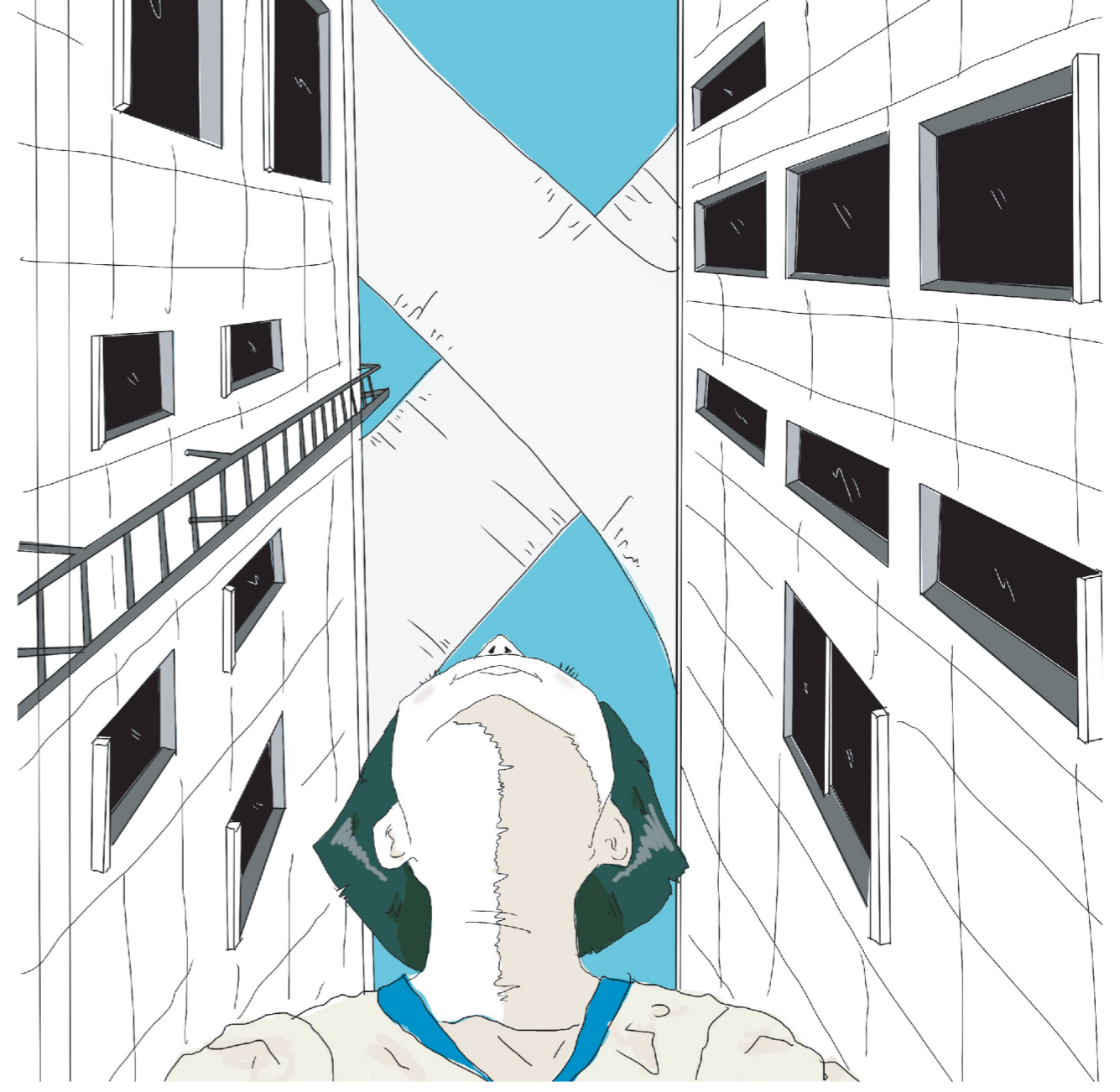

W E L L - B E I N G

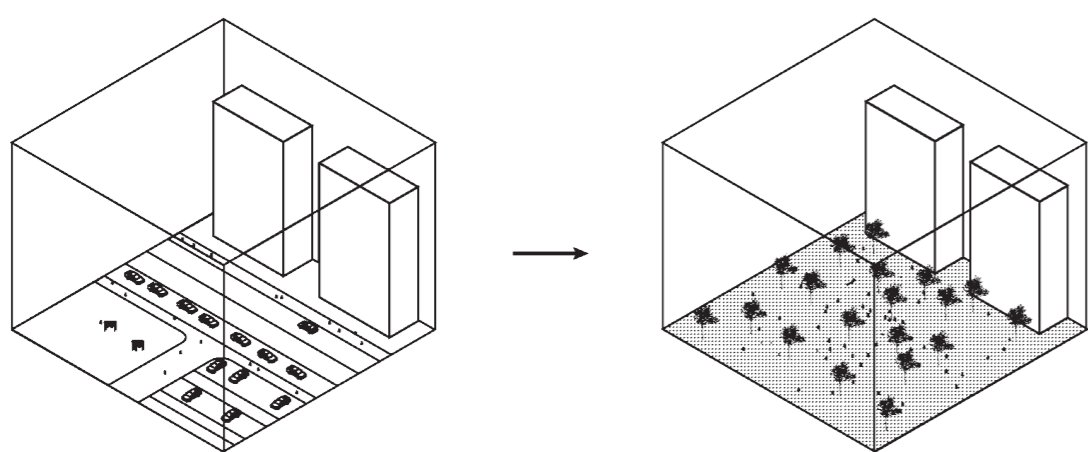

TU Delft

DIMI

PACT

UNS
 UNSTUDIO

RADD.

✕ Gemeente
 ✕ Amsterdam
 ✕

