

DESIGN OF A MINIMALLY INVASIVE SPINAL CAGE APPLICATOR

MASTER THESIS BY
MARK HOEDEMAEKER



Master thesis by: Mark Hoedemaker
Master Integrated Product Design
Specialisation: Medisign
TU Delft, faculty of Industrial Design Engineering
9 Januari 2017 - 17 November 2017
markhoed@gmail.com

Supervisory team:
Chair: Prof.dr.ir. R.H.M. Goossens, Professor of Physical Ergonomics
Mentor: Dr. Y. Song, Assistant Professor
Mentor: S.M. Ahmadi

Medical professional:
G.C.W. de Ruiter, Neurosurgeon

PREFACE

This thesis marks the end of my masters Integrated Product Design at the faculty of Industrial Design Engineering at the Delft University of Technology. You will be reading about the work I have done over the past few months to create a surgical instrument, capable of inserting a new spinal cage between two lumbar vertebrae.

I chose to work on this project because the challenge of creating a surgical tool was very appealing to me. This project has given me great satisfaction in knowing that my work might contribute to a better life of those who require a hernia surgery. I am very thankful for being able to complete this project, and am proud of the result you see before you.

This project would not have been the same without the support of everyone around me. I want to thank my chair Richard Goossens for the feedback and support throughout the project.

I also want to thank my mentor Yu (Wolf) Song for all the great feedback sessions, humor, and insight you have provided throughout the project.

Mohammad Ahmadi, I want to thank you for your feedback on the spinal cage and my designs throughout the project.

Thank you Bertus Naagen for providing me with the measurement equipment for my final test

Thank you Dr. de Ruiten for allowing me to observe the PLIF surgery twice, and for giving me valuable feedback from a surgeon's point of view.

I want to thank my awesome friends, parents, girlfriend Nousjka and everyone around me for all their support, hugs, and advice through every moment of this project.

And finally, thank you my baby boy Jan for making this graduation project extra special.

GLOSSARY

Bayonnetted: A type of instrument with an offset handle. This offset keeps the hand and handle away from the surgeons view on the surgical field.

CE mark: Similar to a 'stamp of approval'. This mark is required before any device may be sold on the European market.

CSSD: Short for, Central Sterile Supply Department. Reusable instruments are cleaned, disinfected, and sterilized here.

Deploy direction: The direction to which the implant hinges when it exits the implant device.

Disinfection: The process of cleaning something, especially with a chemical, in order to destroy bacteria.

Distal: A medical term which describes a point away from the body or point of attachment.

EMG: Short for electromyogram. It is used to measure muscle activity.

ErasmusMC: A hospital in Rotterdam, the Netherlands.

Flexor digitorum: A muscle group which causes the fingers and wrist to flex when contracting.

Gamma ray radiation: A type of radiation commonly used to kill microbes during a sterilization process.

Interbody fusion: A type of spinal surgery that utilizes a bone graft to join two or more vertebral segments.

K-wire: Short for, Kirschner wire. These metal wires are inserted into anatomical structures of the patient. Often used to fixate bone fractures, but for this procedure they are used to guide other instruments to the right location.

Lumbar: A medical term for the lower region of the back.

MDR: Short for Medical Device Regulation. This is a document containing all the regulations to which a medical device needs to comply.

MIS: Short for, Minimally Invasive Surgery. This is a type of surgery aimed at causing a minimal amount of tissue damage to the patient.

NASA-TLX: A method for measuring the workload of a given task.

NDA: Short for, Non-Disclosure Agreement. This is a contract between two parties which states that the discussed information stays secret.

NiTinol: A nickel and titanium alloy with shape memory properties.

O-Arm: An device with an 'O' shape which surrounds the patient and is used to make x-ray images of the surgical area during the surgery.

OR: Short for, Operating Room: This is where surgeries are performed.

PLIF: Short for, Posterior Lumbar Interbody Fusion. This is the type of surgery during which the implant will be inserted.

Posterior: A medical term which describes a point further to the back of the body.

Precision grip: The way of grabbing hold of an item between the opposed tips of the fingers and the thumb.

Proximal: A medical term which describes a point close by the body or point of attachment.

Spinal cage: The name for the implant which is and implanted between two vertebrae to restore the correct distance between the vertebrae.

Sterilization: The process of making something free from bacteria or other living microorganisms.

Thenar muscles: A group of muscles which causes the thumb to flex.

Tubular retractor: Metal tubes used during a surgery to create an opening into the skin of the patient, through which instruments can be inserted into the body of the patient.

SUMMARY

Analysis

The report starts off with an explanation of the origin of this project, and the forming of the design brief. In this design brief it is stated that an instrument needs to be designed which inserts an implant called a spinal cage in between two vertebrae during a hernia surgery. What follows is the analysis of the surgical procedure, the effects of a hernia, and other surgical instruments used in this procedure. It is identified that the hernia operation in which the instrument is used, is identified as a minimally invasive PLIF technique.

Then, the type of product itself is analysed. The required functioning of the so called spinal cage inserter is analysed. Four functional areas are identified. A comparison is made between existing spinal cage applicator systems. It is determined that the shape and functioning of the applicator is greatly determined by the functioning of the spinal cage itself.

To gain more understanding about the context and the users of the spinal cage applicator, a workflow analysis is performed. For this analysis three observations are done, two of a PLIF surgery and one at the sterilization department of the Erasmus MC. In this analysis it is determined that the workflow of a typical spinal cage applicator can be greatly improved, especially while preparing the applicator before the spinal cage insertion, and removing the need for sterilization. This chapter ends with a summary of the applicable rules and regulation to which the final design should adhere before it may be used in an actual surgery.

Synthesis

A short description of the ideation phase is given at the start of this chapter. In this phase it was found that a disposable syringe-like design was suited best as a starting point for the following designs. Then the design process is explained. The process chosen for this assignment is the lean startup process. This is chosen because the design is already predetermined for a large part and this process is more focused on developing a design with a lot of iterations in quick succession.

The first design is presented as a shaft through which the spinal cage can be inserted into the body. A pusher is used to push the spinal cage down the shaft into the body. The design is dismissed since some functionality errors are found after the prototype was build.

An improvement is presented in the second design. This design incorporates a pusher with a connection to the spinal cage to prevent the spinal cage to slide down the shaft on it's own. This design also introduces the cartridge, containing the spinal cage, which allows the user to quickly load the applicator. It also contains a blocking mechanism to stop the cage from sliding down the shaft on it's own. This design is tested on a simulated anatomical structure with multiple test subjects.

A third iteration is presented as an improvement over the second design. This design contains a precision grip for better control of the pusher. A new blocking mechanism in the form of a tear through layer is presented. The cartridge contains markings which help to identify the correct orientation of the instrument. These additions are the result of another small test to see which details were the best received according to the test subjects. This third design is tested on a larger, more realistic test setup. During this test, the workload produced by the instrument is evaluated, as well as the usability of the new design. The design is found to be easy to learn and intuitive to use.

Detailing

During the detailing, the materials, production process, packaging, and batch size are determined. The batch size of the spinal cage will be 10.000 pieces, according to it's manufacturer M. Ahamdi. Since there are two cages used per surgery, the batch size of the applicator is determined to be 5000, annually. The material used for the applicator and cartridge is chosen to be clear polycarbonate (PC) and AISI 410 stainless steel for the pusher. The plastic parts will be manufactured using injection molding and the metal parts using machining. The final product will be packaged in a Tyvek peel pouch.

Final design

The final design is called the ClearFix. The production costs are estimated to be €5,49. It is also decided that the ClearFix will be given for free with the spinal cages. The final design is made from clear plastic to further enhance the surgeon's view on the surgical area, and incorporates an updated connection between pusher and spinal cage. The blocking mechanism is also updated for the final design since the previous version was determined to be dangerous for actual use.

The final workflow greatly reduces the workload of the scrub nurse when preparing the spinal cage applicator. The disposable nature of the ClearFix also eliminates the need for sterilization, making the processing of the instrument after use a lot easier.

Evaluation

This part contains reflections on the process of the project, the final design, and personal experiences. After the reflections, the conclusions and recommendations are presented, ending the main report of this master thesis.

TABLE OF CONTENT

ANALYSIS	
1. Assignment	1
1.1 Intro	
1.2 Problem analysis	
1.3 Assignment definition	
2. Background information.....	3
2.1 Intro	
2.2 Lumbar hernia anatomy	
2.3 Diagnosing a herniated disc	
2.4 Interbody fusion	
2.5 Instruments	
2.6 Conclusion	
3. Product.....	11
3.1 Intro	
3.2 Product description	
3.3 Existing products	
3.4 Materials	
3.5 Conclusion	
4. Workflow analysis.....	17
4.1 Intro	
4.2 Workflow	
4.3 Users	
4.4 Conclusion	
5. Rules and regulations.....	23
5.1 Intro	
5.2 MDR Annex 1	
5.3 ISO 14971	
5.4 MDR Annex 8	
5.5 Conclusion	

SYNTHESIS

6. Design process.....	27
6.1 Ideation methods	
6.2 Lean startup	
7. Design 1	29
7.1 Design	
7.2 Prototype	
7.3 Conclusion	
8. Design 2	31
8.1 Design	
8.2 Prototype	
8.3 Test	
8.4 Results	
8.5 Conclusion	
9. Design 3	35
9.1 Design	
9.2 Prototype	
9.3 Test	
9.4 Results	
9.5 Animal test	
9.6 Conclusion	

DETAILING

10. Materials	47
10.1 Intro	
10.2 Batch size	
10.3 Plastics	
10.4 Metals	
11. Packaging.....	50
11.1 Intro	
11.2 Tyvek	
11.3 Division	
11.4 Processing	
12. Production process	51
12.1 Intro	
12.2 Applicator and cartridge	
12.3 Pusher	

DESIGN PROPOSAL

13. Final design	55
13.1 Intro	
13.2 General description	
13.3 Risk analysis	
13.4 Parts	
13.5 Costs	
13.6 Dimensions	
14. Workflow	67
14.1 Intro	
14.2 Workflow	
15. Evaluation.....	69
15.1 Reflection	
15.2 Conclusion	
15.3 Recommendations	
16. References.....	75

ANALYSIS



1. ASSIGNMENT

1.1 INTRO

In order to gain a good understanding of what needs to be designed, a proper analysis needs to be conducted. In this analysis the context, the users and the product itself will be analysed. This will be done using a variety of research methods. For the main part, the research will be conducted using literature research. The users and a part of the context will be analysed using a workflow analysis.

figure 1.1: Spinal cage

The initial design for the spinal cage used in this project.

1.2 PROBLEM ANALYSIS

This graduation assignment is part of a larger project titled:

“Minimally invasive multi-segment spinal cage with nitinol hinges”.

A spinal cage is a surgically placed implant which facilitates a proper fusion between two vertebrae. The fusion is done to treat lower back pain resulting from a herniated disc. The goal of this larger project is, as the title suggests, to create a spinal cage which tries to solve two contradictory goals:

“...there is a tendency to implant smaller cages to reduce the risk of damaging nerve roots, or the innervation of the psoas muscle. Furthermore, smaller cages also cause less scarring and reduce the incidence of post-surgical complications. However, in order to have better bone ingrowth and reduce the chance of implant dislocation during the fusion time, more surface contact between a spine cage and vertebrae is needed.”

The spinal cage (figure 1.1) will be 3D printed using laser sintering and made from titanium (Ti6Al4V). The hinges will be made from nitinol. It is not yet determined whether the hinges will make use of the elastic or shape memory properties for deployment. The main advantage of this spinal cage over existing ones is the possibility for extra bone ingrowth through porous areas in the spinal cage.



At the moment no tools are available which are able to place and deploy the spinal cage into the body. This is because the spinal cage requires a specialized tool which takes into account the dimensions and deployment method of this particular cage. The cage may also require a special bone graft placement tool since existing systems are inadequate in placing graft material around this cage.

1.3 ASSIGNMENT DEFINITION

Following the problem analysis the graduation assignment can be defined as:

DESIGN A SURGICAL INSTRUMENT OR SET OF INSTRUMENTS FOR THE "MINIMALLY INVASIVE MULTI-SEGMENT SPINAL CAGE WITH NITINOL HINGES" PROJECT WHICH FACILITATE THE PLACEMENT AND DEPLOYMENT OF THE SPINAL CAGE AT THE INTENDED LOCATION INSIDE THE BODY.

2. BACKGROUND INFORMATION

2.1 INTRO

A lumbar hernia is treated using a surgical procedure called an interbody fusion. This part will help with understanding what a hernia is and contains information about the interbody fusion procedure. This is done by explaining the relevant anatomy (figure 2.1), the diagnostic steps, the interbody fusion itself and which instruments are commonly used during the procedure.

2.2 LUMBAR HERNIA ANATOMY

When someone is diagnosed with a hernia, the patient suffers from a failure of an intervertebral disc. This can occur to any intervertebral disc but is most common for the lumbar region of the spine. The lumbar vertebrae are numbered L1 through L5 with L1 connecting to the thoracic part of the spine and L5 connecting to the sacrum. An intervertebral disc sits in between two vertebrae. It acts as a cushion or damper for forces acting down the spine and facilitates movement between the vertebrae. The disc consists of two main parts, the gelatinous center called the nucleus pulposus and a fibrous outer layer which consists of 15 to 20 collagenous laminae. These are collectively called the annulus fibrosus. The direction of the fibers in these laminae changes per layer. At the posterolateral side of the disc, the annulus is thinner creating a weak spot in the intervertebral disc (Gaillard, & Knipe, n.d.).

Within the lumbar region, the most common discs to suffer from herniation are those between L4 and L5 (L4-L5 hernia), and L5 and the sacrum (L5-S1 hernia). General degeneration of the disc and trauma can cause the nucleus to herniate through the annulus fibrosus into the spinal canal (“Lumbar Herniated Disc Video”, 2017; Peter F. Ullrich, 2017; ruggenmerg, 2017).

The spinal nerves pass through a large hole in the vertebrae called the foramen. These foramen line up to create the spinal canal. The spinal canal is protected by the lamina which are the arches on the posterior side of the spine. The spinal cord comes down from the brain, through the cervical and thoracic vertebrae until the second lumbar vertebrae (L2). From this point the spinal cord changes into a bundle of separate nerve roots called the horse’s tail (cauda equina). Between every vertebra a pair of nerve roots exit the spinal canal, one to the left and one to the right. When exiting the spinal canal, these roots pass over a weak spot in the spinal disc. When the intervertebral disc herniates at this weak spot, the herniation can press against the exiting nerve root possibly causing leg pain (“Lumbar Herniated Disc Video”, 2017; Peter F. Ullrich, 2017; ruggenmerg, 2017).

Since a herniation can occur at any location on the intervertebral disc, a nerve root does not necessarily have to be pinched off. Also, patients with a confirmed herniated disc will sometimes experience no pain symptoms (“Lumbar Herniated Disc Video”, 2017).

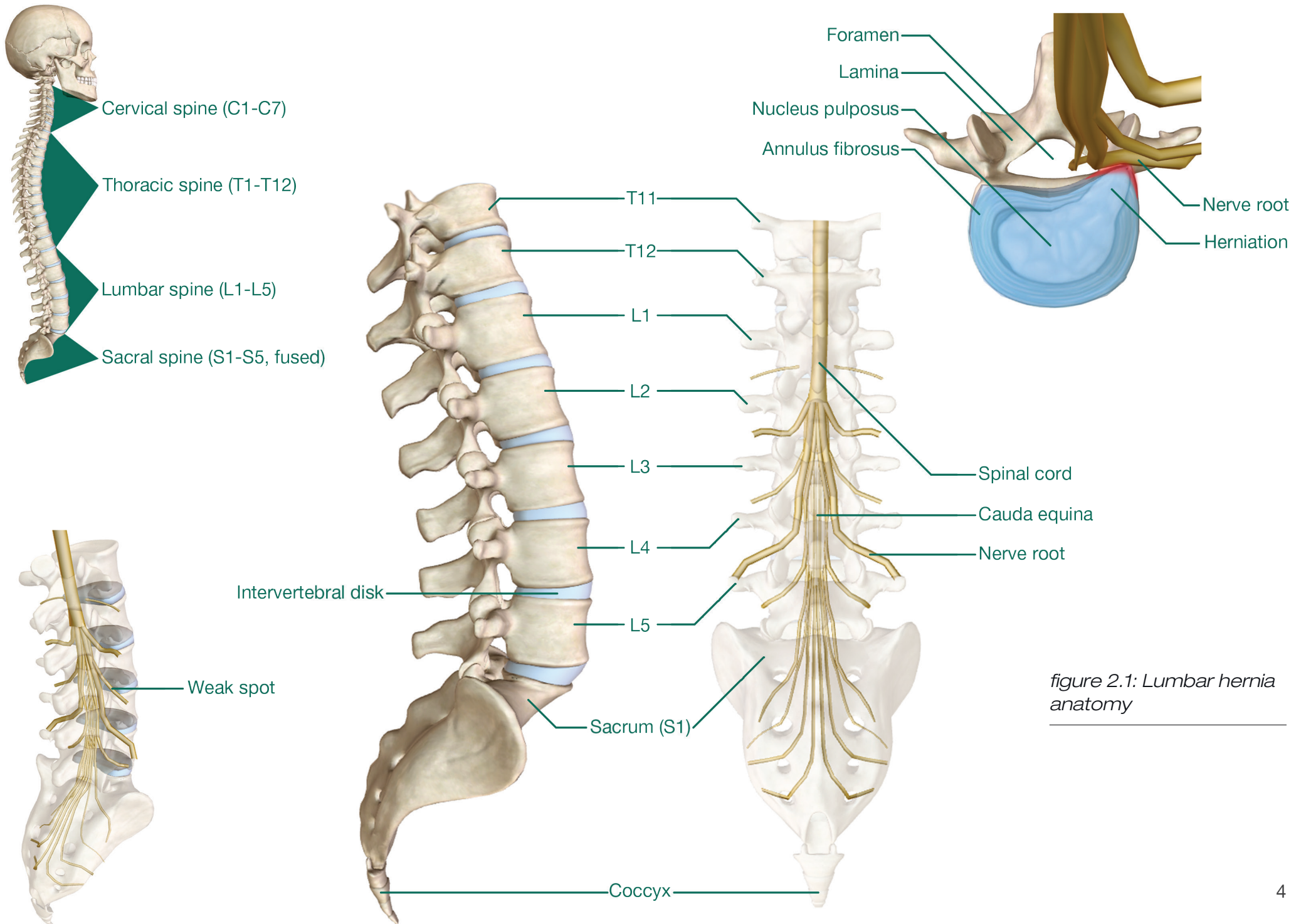

figure 2.1: Lumbar hernia anatomy

2.3 DIAGNOSING A HERNIATED DISC

Not every lumbar hernia causes symptoms in the same area (“Herniated Disk in the Lower Back-OrthoInfo - AAOS”, 2017; Jason M. Highsmith, 2017; “Lumbar Herniated Disc”, 2017), this is because different nerves pinched off cause different areas in the lower extremities to experience symptoms (figure 2.2).

Symptoms for a herniated lumbar intervertebral disc are:

- Lower back pain;
- Muscle cramps;
- Pain radiating down the legs (Sciatica);
- Numbness or tingling in one or both legs;
- Muscle weakness in one or both legs;
- Loss of reflexes in one or both legs;
- In very rare cases: loss of bowel and/or bladder control.

figure 2.2: Lumbar hernia symptom areas

Different affected nerves cause different areas to experience symptoms.

figure 2.3: Interbody fusion variations

Image shown on right page.

The first step in diagnosing a patient with a herniated disc is by conducting physical tests. Often, a physical test is sufficient to make a diagnosis. When the physician is not certain, he might conduct additional diagnostic tests. These tests can be done using the following techniques (“Diagnosis - Herniated disk - Mayo Clinic”, 2017; Philip R. Shalen, 2017):

- X-ray
- CT-scan
- MRI
- Myelogram
- Discogram

If a herniated disc is confirmed, a decision is made how to treat the hernia. Often a surgery will not be necessary for a hernia. Rest, anti-inflammatory medication and physical therapy can often result in a complete removal of symptoms. However, when the symptoms persist or increase in severity, a decision is made to perform surgical treatment. The surgical technique which is used in this project is an interbody fusion (“Herniated Disk in the Lower Back-OrthoInfo - AAOS”, 2017).

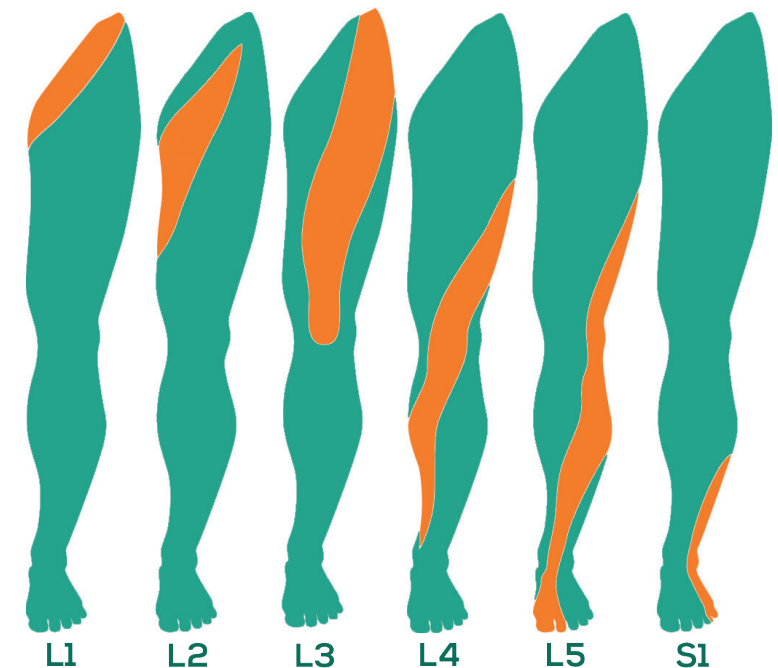

2.4 INTERBODY FUSION

An interbody fusion operation is a surgical procedure where two or more vertebrae are fused together at the location of the intervertebral disc. This is done by removing the intervertebral disc and replacing it with one or more fusion implants (spinal cages) to maintain spine height and alignment, and bone graft. The bone graft is there to improve the growth rate of the bone, improving the fusion rate. Depending on the used method, structures of the to be fused vertebrae may be removed to gain access to the intervertebral disc space. There are currently six main methods of approaching the spine and performing an interbody fusion surgery (figure 2.3) (Wiltfong, Bono, Charles Malveaux, & Sharan, 2012; Shen, Samartzis, Khanna, & Anderson, 2007; Yeung & Yeung, 2007):

- PLIF (Posterior Lumbar Interbody Fusion) - The intervertebral disc is approached from the back.
- TLIF (Transforaminal Lumbar Interbody Fusion) - The intervertebral disc is approached from the back but at an angle to either side of the spine.
- LLIF or XLIF (Lateral Lumbar Interbody Fusion) - The intervertebral disc is approached from the side.
- OLLIF (Oblique Lateral Lumbar Interbody Fusion) - The intervertebral disc is approached from the side but at an angle, through the Kambin's triangle.
- ALIF (Anterior Lumbar Interbody Fusion) - The intervertebral disc is approached from the front.
- AxiaLIF (Axial Lumbar Interbody Fusion) - The intervertebral disc is approached from the bottom of the spine.

The proposed procedure for this project is a minimally invasive PLIF operation.

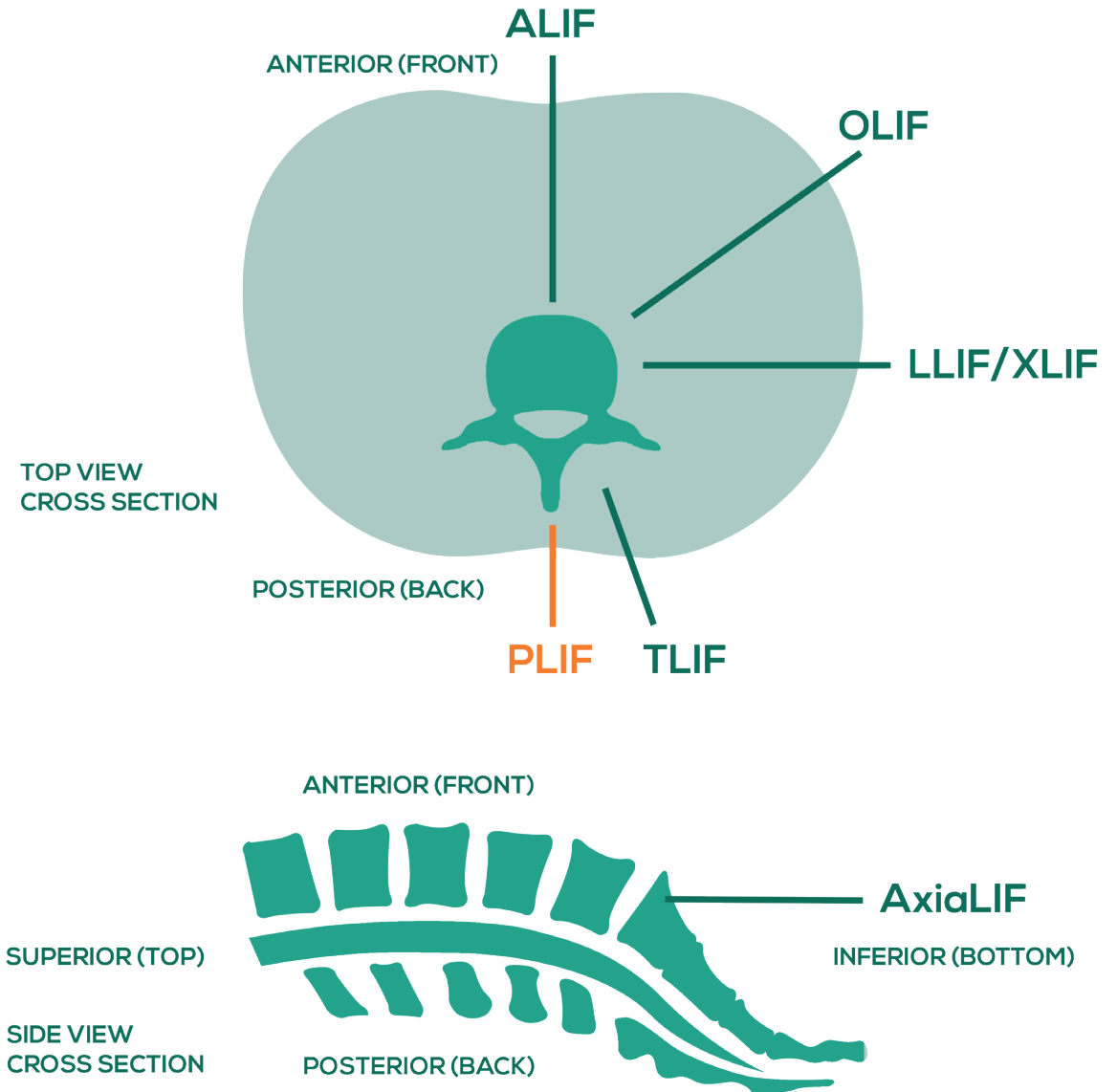

2.5 INSTRUMENTS

The applicator is not the only instrument used during the surgical procedure. Many different instruments are needed to complete the complex task. Each with its own special function. The instruments which are commonly used for this procedure are explained in this part and are divided into their respective functional categories (Pathway AVID Surgical Technique, n.d.; T-PAL Surgical Technique, 2016).

Cutting

The tools which are used for cutting are the scalpels and osteotomes (figure 2.4). The scalpel is one of the most recognizable medical instruments and is used for cutting through soft tissue. In a PLIF surgery it is used to open the skin and to create an opening in the intervertebral disc. A bayoneted scalpel is used for creating an opening in the intervertebral disc. Bayoneted instruments are used in small operating areas and ensure that the hand of the surgeon is not blocking his or her view. Osteotomes resemble a chisel and are used to cut away hard bony structures. In a PLIF procedure it is used to cut away the facet joint.

figure 2.4: Cutting tools

Left image.
An osteotome is shown on the left and a scalpel is shown on the right.

figure 2.5: Surface treatment tools

Right image.
A rasp is shown on the left and a shaver attachment for a T-handle is shown on the right.



Surface treatment

The surface treatment tools used in a PLIF surgery are the rasps, scrapers and shavers (figure 2.5). In the PLIF procedure the rasp is used to remove the cartilaginous layers from the vertebral endplates and expose the bleeding bone. Scrapers and shavers are tools which, as the names suggest, scrape and shave away material. For this procedure the shaver and scraper are used to remove material from the intervertebral disc. These instruments are often bayoneted and attached to a T-handle. This is a handle to which many different instruments can be attached.



Retracting

Often, tools are required to keep certain tissues out of the operating field. For a PLIF procedure, these instruments are the dilator tubes, tubular retractors and retractors (figure 2.6). The dilator tubes are slid over the K-wire with increasing diameters. This separates the muscles, causing less damage while still creating an opening. The tubular retractor is then slid over the dilator tubes and the dilator tubes and K-wire are removed. This creates an opening through which the surgeon can operate. The retractor is a hooked instrument which is used to anatomical structures away from the surgical field.

Extracting

In order to make room for the spinal cage, biological material will have to be removed. The instruments which are used for this are the curettes, rongeurs and to aid with extraction, the slap/slide hammers (figure 2.7). The curette has a loop or cup which is used to scoop or scrape away soft tissue and extracting it from the body. The other extracting tool is the rongeur. This tool has two scoop shaped tips which can open and close. The construction depends whether the rongeur is used for bone or soft tissue removal. For this procedure soft tissue rongeurs are used to remove the soft tissue inside the intervertebral disc. Slap/slide hammers are attached to surgical equipment and used to remove equipment which is stuck and difficult to remove.



figure 2.6: Retraction tools

*Left image.
Three dilator tubes are shown on the left and a tubular retractor is shown on the right.*

figure 2.7: Extraction tools

*Right image.
A slap hammer is shown on the left, a rongeur is shown in the middle and a ring curette is shown on the right.*

Inserting

Placing implants is an important part of this surgical procedure and this project. The tools which are used for implanting are the spinal cage applicator, impactors, graft inserters and mallets (figure 2.8). Ofcourse the spinal cage applicator is the to be designed instrument and will be used to insert the spinal cage in between the vertebrae. The impactor and graft inserter are two instruments working together to insert bone graft into the intervertebral disc space. The bone graft is inserted with the tube like inserter and then pushed into place using the impactor. The mallet is used to help insert instruments which require extra force. It is also used with the osteotome to remove the facet joint.

Additional equipment

Additional equipment are the K-wires, flex arms and the trial implants (figure 2.9). The K-wires are used to pinpoint the surgical area and to guide the dilator tubes to this area. The flex arms are used to stabilize the tubular retractors OR table. The trail implants are used to measure the height of the intervertebral space, to find out the proper size of the spinal cage.

figure 2.8: Insertion tools

Left image.

An impactor is shown on the left, a mallet is shown in the middle and a bone graft inserter is shown on the right.

figure 2.9: Additional equipment

Right image.

A flex arm is shown on the left and a K-wire is shown on the right. The K-wire is shortened for clarity.



2.6 CONCLUSION

An intervertebral disc hernia is caused by trauma which causes the annulus fibrosus to deteriorate. Not every hernia requires treatment since not every hernia causes symptoms. Symptoms mostly occur when a herniation of the intervertebral disc presses against the passing nerve root. A common treatment is pain medication and physical therapy, however when the symptoms persist a surgical procedure may be required.

A spinal fusion surgery can be performed with six different methods. These methods vary in the direction from which the intervertebral disc is approached. During all these procedures, a spinal cage (figure 2.10) is placed between two vertebrae to restore the height between the vertebrae, and reduce pressure on the pinched nerve root. This project will focus on the minimally invasive PLIF version of the surgical procedure, requiring the spinal cage applicator to be compatible with this procedure.

There is a large variety of instruments used during an interbody fusion. The to be designed applicator should be able to work in tandem with these instruments to avoid damage to either the applicator or the other instrument, and to enable a smooth process.



figure 2.10: Typical spinal cages.

(xtant medical, n.d.)

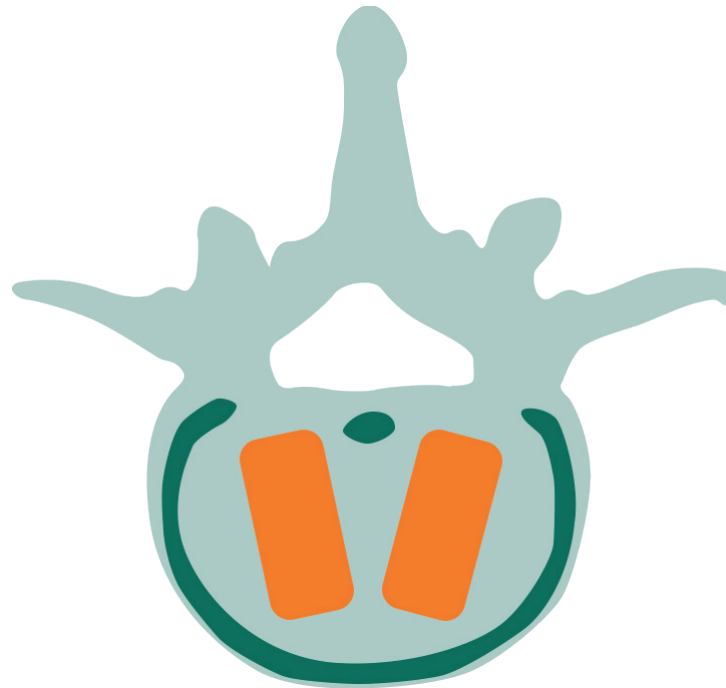

figure 2.11: Typical spinal cage placement

3. PRODUCT

3.1 INTRO

For this graduation project a minimally invasive lumbar spinal cage applicator has to be designed. However, since this is not an everyday product, a product analysis is required to gain understanding of its form and function. This part will go into detail on what a spinal cage applicator is to give a good understanding on the product and help understand its basic functionality. This part will also show some variations in existing spinal cage applicator designs. This is to gain knowledge on the current state of the art, and how different manufacturers approached a spinal cage's functionality. The intended function, the sterilization methods and longevity of these applicators cause a difference in material demands. Therefore, commonly used biomedical materials will be discussed at the end of this part.

3.2 PRODUCT DESCRIPTION

A minimally invasive lumbar spinal cage applicator (figure 3.1) is a medical device with the function of inserting a spinal cage into the intervertebral disc space between two lumbar vertebrae. For starters, to do so, it is required to contain a spinal cage. This cage may be pre-attached or attachable. Next, the spinal cage must be positioned between in the intervertebral disc space. Finally, the spinal cage requires to be detached from the applicator. And finally, the applicator will need to be retracted from the body.

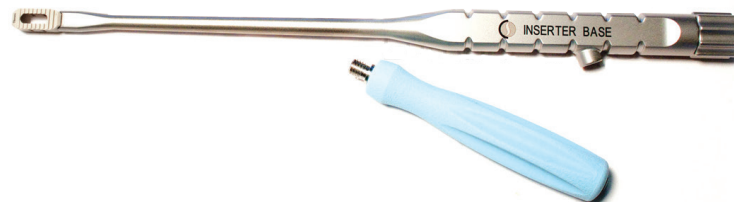

figure 3.1: Spinal cage applicator

This image shows a typical spinal cage applicator from Fuse Lox.

Functional areas

A spinal cage applicator can be divided into several functional areas: A, B, C and D (figure 3.2). Area A is the part which will insert the spinal cage into the intervertebral space. Area B requires to be long and narrow component of the applicator. This part will enter the body and serves as extension and connective part between area A and C. Area B should also allow for the control input to reach area A if needed. Area C is where the user can hold and position the applicator. Just like area B, it should also allow for the control input to reach area A. The final area D contains the controls to manipulate the spinal cage.

Reusable and disposable

The spinal cage applicator can be made to be completely reusable, semi-disposable or completely disposable. The reusable and disposable modes of use will ask different demands from the materials and the geometry. A reusable device needs to minimize the risk of cross-contamination. Therefore the material will have to be, depending on the sterilization process: resistant to temperatures up to 135 degrees centigrade, corrosion resistant, radioactive resistant, moisture resistant and/or resistant to certain chemicals. The geometry of a reusable instrument requires to be smooth and rounded with no small nooks and crannies since bacteria and debris can get trapped there, possibly causing cross-contamination. This also requires the material to be scratch and crack resistant since scratches and dents could also trap bacteria and debris (Jolanda Buijs, personal communication, june 2014). A disposable device does not have to be concerned with cross-contamination since it will only be used once. Therefore it will only require to be sterilized once and thus has lower demands for resistance against the different process types. It also does not have to be as scratch resistant as a reusable device since cross-contamination is less of an issue.

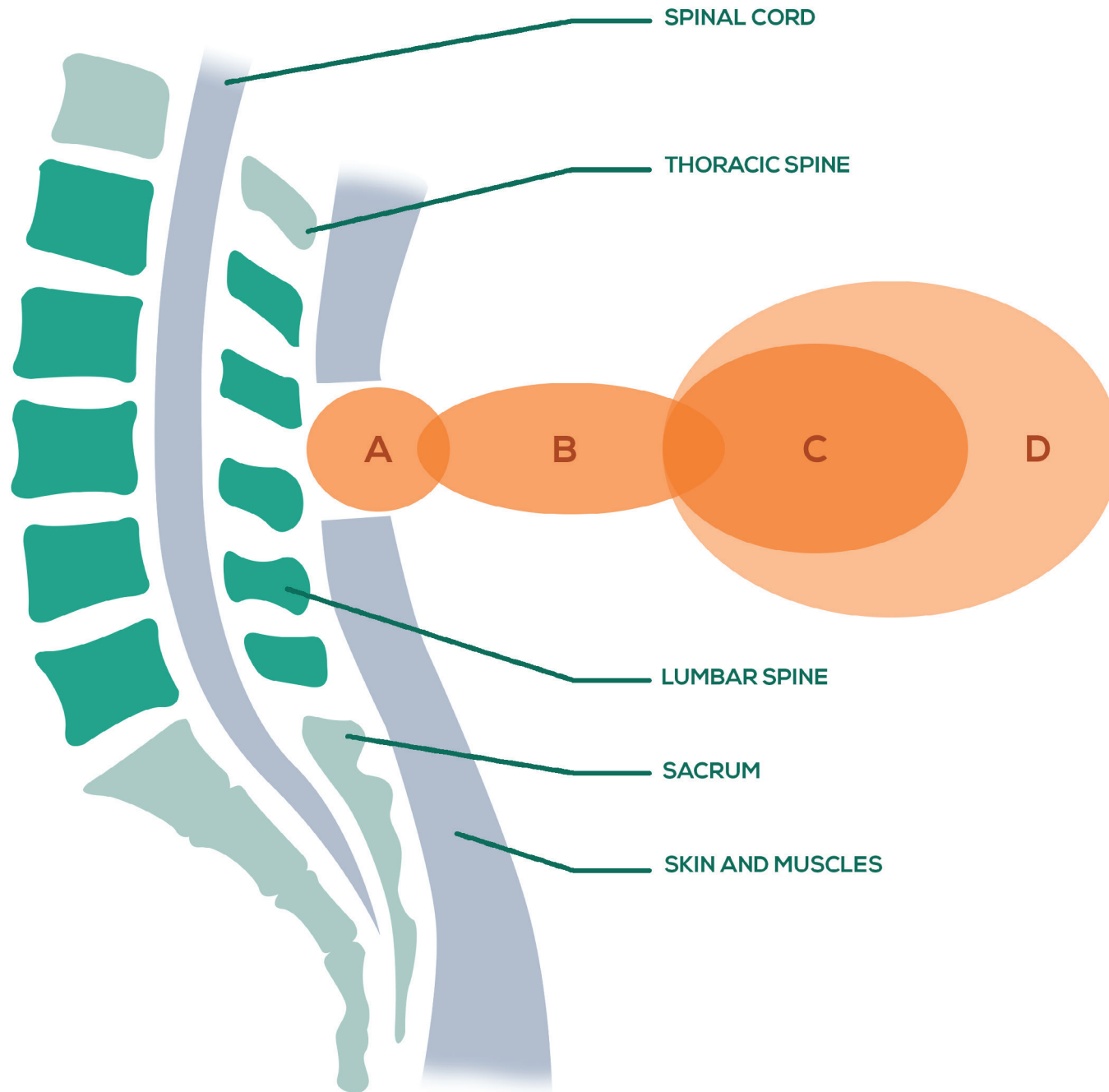

figure 3.2: Functional areas of a spinal cage applicator

3.3 EXISTING PRODUCTS

Due to the large amount of applicators, a smaller selection has been made to present the possible variations of the applicator system. These 9 applicators all vary in complexity and functionality (figure 3.3). A large part of the applicators is reusable with a smaller part being disposable or semi-disposable. One might think that in order to allow for easy cleaning and sterilization, the reusable applicators have simpler geometry but this is not always the case. The most complex applicators are often those who are reusable. Only applicator number 3, the WeSHARE applicator is very basic without any controls or complex geometry. This can be explained by being the only applicator from this list without a need for controlling the spinal cage.

What can also be seen is that the applicators either have a straight handle and thus look a lot like a screwdriver, or they have an angled handle which makes them more gun shaped. Functionally, this has an effect on what type of controls are used. The gun shaped applicators seems suitable for both squeezing and rotating controls while screwdriver shaped applicators tend to use rotating knobs more often.

The attachment methods between the spinal cage and the applicator vary as well. The most common method of connecting a cage to an applicator is by using a screwing thread. Other connection methods are by clamping and by having the cage pre-loaded onto the applicator. A pre-loaded cage is often found in disposable applicators.

The main material used for the reusable applicators is metal, with the handle often being made from a type of plastic. Metals tend to be more durable, which is beneficial for reusable devices. The semi-disposable and disposable applicators are mostly made from plastics, sometimes with metal parts when extra durability or stiffness is required. Plastics are more commonly used in semi-disposable and disposable instruments because plastics are often less expensive, which is beneficial for a disposable device.

A more detailed description of the individual applicators can be found in appendix A.



Reusable

Pivoting cage

Clamping cage connection

1



Reusable

Articulated cage

Screwing cage connection

2



Reusable

Standard cage

Pressing cage connection

3



Disposable

Articulated cage

Pre-loaded cage connection

4

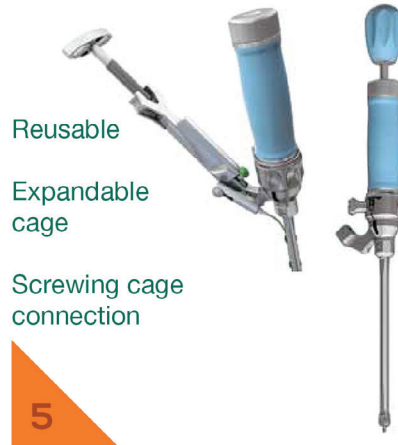

Reusable

Expandable cage

Screwing cage connection

5



Reusable

Articulated cage

Screwing cage connection

6



Pivoting cage

Screwing cage connection

7



Semi-reusable

Expanding cage

Pre-loaded cage connection

8

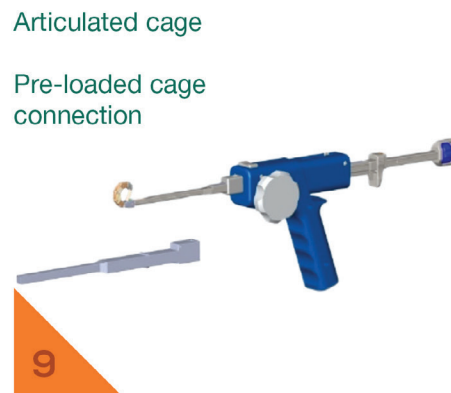

Articulated cage

Pre-loaded cage connection

9

figure 3.3: Existing spinal cage applicators

1. T-PAL spacer applicator by DePuy Synthes

2. AVID inserter by Custom Spine

3. WeSHARE applicator by Yellowsteps

4. Luna 3D implant inserter by Benvenue Medical

5. AccuLIF applicator by Stryker

6. FLXfit 3D expandable cage applicator by Expanding Orthopedics

7. IMPIX-TLIF applicator by Medicea

8. StaXx XD Posterior VBR Device by Spinewave

9. PROW FUSION delivery tool by NLT Spine

3.4 MATERIALS

The materials used vary per intended function of the part and longevity of the applicator. For reusable applicators the materials are most often metals since most metals are better suitable for multiple sterilization cycles. Metals are less likely to deform and experience deterioration because of the heat, radiation or chemicals used in the sterilization processes. However, metals are susceptible to corrosion and pitting because of the acidic fluids in the human body. This is why the metals which are used for medical equipment require to be better resistant to corrosion than metals used in everyday objects. Commonly used metals are stainless steel grades like austenitic 316 and titanium alloys like Ti6Al4V (“Stainless Steel - Grade 316 (UNS S31600)”, 2001; “Titanium Alloys - Ti6Al4V Grade 5”, 2002; “Which Alloy is Best for My Surgical Instruments?”, 2013). Plastics which are able to survive multiple sterilization processes include but are not limited to PEEK, PA, PSU and PES (Modjarrad & Ebnesajjad, 2013).

Disposable instruments are also often made from metals because of their mechanical properties. However the metals used in disposable instruments are cheaper than those used in reusable instruments. For this reason the most commonly used metal for disposable instruments is stainless steel. Plastics are more likely to be used in disposable instruments since these instrument only have to survive one sterilization cycle (Appendix B, part 5). This increases the number of suitable plastics. Another reason for using plastics is because plastic parts are easy to mass manufacture and relatively cheap, further reducing costs.

The materials shown in graph 3.4 have excellent resistance to all the sterilization processes, and graph 3.5 shows materials which are able to survive all the types of sterilization for at least one cycle. What can be seen is that a lot more plastics become available when only one sterilization cycle is required. These might not be as strong as metals but are a lot cheaper than most metals. But as long as the instrument is able to perform it’s function properly and safely, these materials can be used for medical instruments.

3.5 CONCLUSION

The spinal cage applicator contains four main functional areas. How these areas are filled in depends largely on the insertion and deployment mechanism. A more complex mechanism which is difficult to dismantle and sterilize might be more suitable for a disposable design. However, if the applicator is preferred to be reusable the design should be simpler. Nevertheless, the instrument should be able to pass through at least one sterilization process, regardless of being a reusable or disposable design. This also sets some limits to the materials which are suitable. When designing a reusable applicator there are notably less materials to choose from, especially plastics are unsuited for reusable instruments.

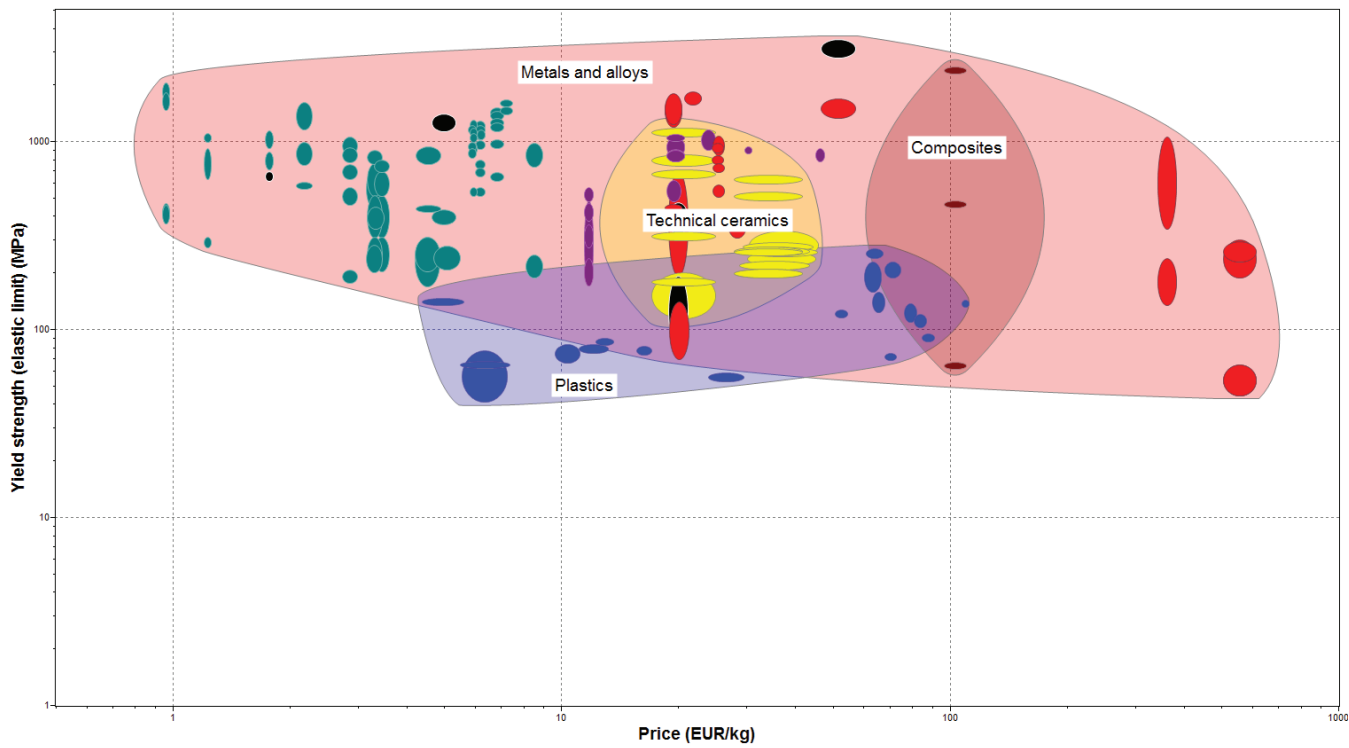

graph 3.4: Reusable materials

Materials shown in this graph are able to survive multiple sterilization cycles without compromising integrity.

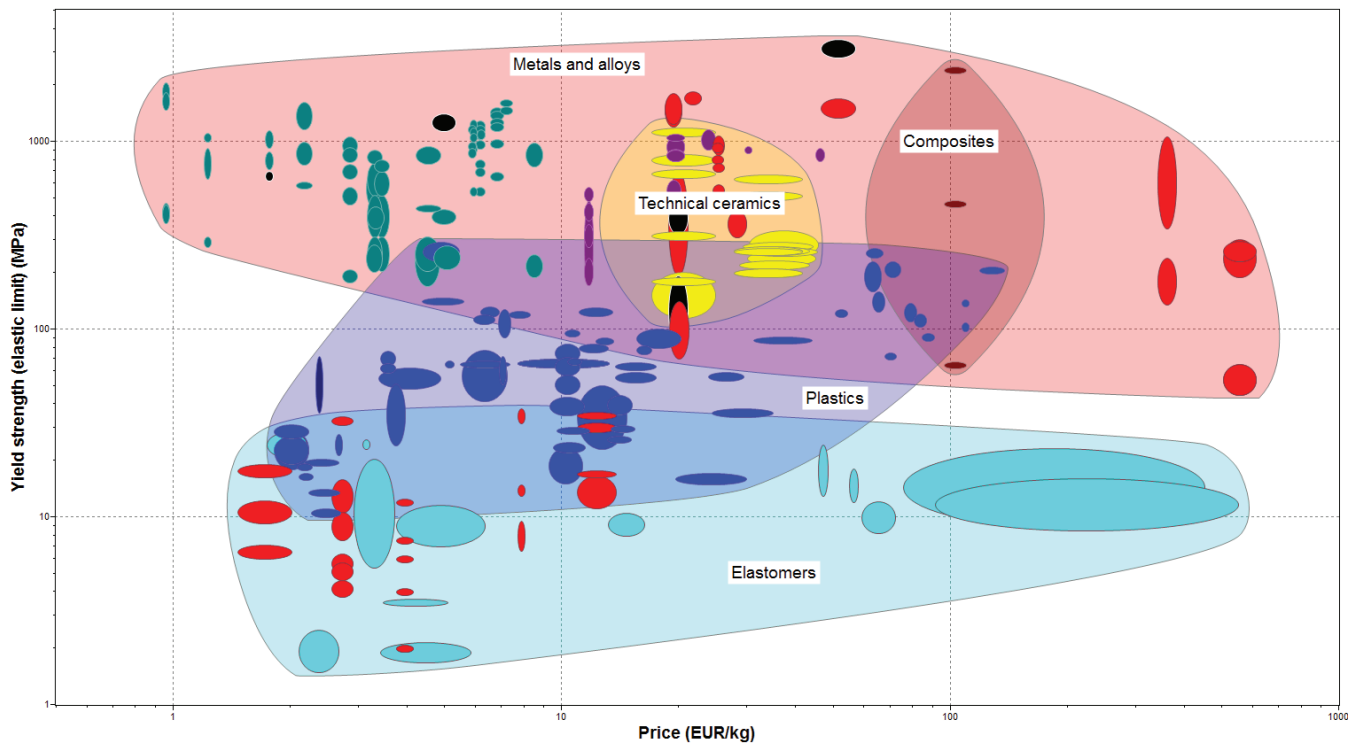

graph 3.5: Disposable materials

Materials shown in this graph are able to survive at least one sterilization cycle without compromising integrity.

4. WORKFLOW ANALYSIS

4.1 INTRO

To get an understanding of the processes a spinal cage applicator undergoes, a workflow analysis was made. This analysis will shed some light on how an instrument like this is handled and how a new design would fit best into the current workflow at the OR (figure 4.1) and possibly, the CSSD. A reusable device will cycle between the CSSD and the OR. However a disposable device will only be used in the OR. The objective of this workflow analysis is to gain an overview of the current working process and be able to adapt the applicator design as best as possible for this process and improve where possible.

figure 4.1: Operating room context

A PLIF surgery is being performed in this operating room.



4.2 WORKFLOW

Operating Room

The applicator is used for a small moment, only for a period of about 15 to 20 minutes (appendix B, part 5, part 6), during a generally 2.5 hour long PLIF surgery. The surgery consists of 5 main phases:

- Preparation and opening the patient;
- Decompression and discectomy;
- Pedicle screw placement;
- Spinal cage placement;
- Rod placement and closing the patient.

The workflow of each phase and the overall workflow of the surgical procedure is shown in appendix B, part 1. The workflow steps performed during the applicator's use in the OR are shown in figure 4.2. These steps have to be performed twice since two spinal cages are to be placed.

First, the spinal cage is screwed onto the applicator by the scrub nurse, then the spinal cage is filled with bone graft by the scrub nurse. This takes about 1 minute, 11 seconds (appendix B, part 6). During these steps, the scrub nurse also has to hand over instruments to the surgeon. This causes the steps to take more time than necessary. This cumbersome multitasking can be avoided if the preparation time is reduced far enough.

Then, the neurosurgeon will place the spinal cage into the intervertebral disc space, hammer the spinal cage into place, and unscrew the spinal cage. This takes about 25 seconds (appendix B, part 5, part 6). Here, workflow improvements are hard to find, as the actions performed by the surgeon are already quite short, simple, and effective.



Scrub nurse

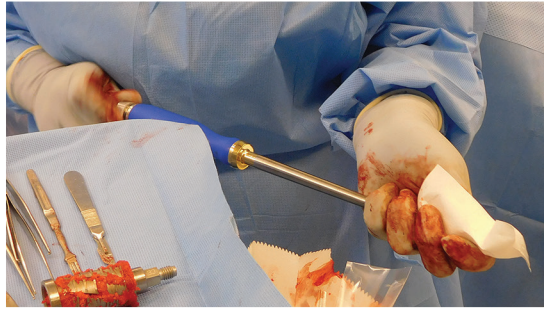

Screw spinal cage onto applicator



Fill spinal cage with bone graft

figure 4.2: Workflow steps spinal cage placement

Steps performed during the spinal cage placement phase during a PLIF surgery.



Average total completion time: 1:11 minutes



Surgeon

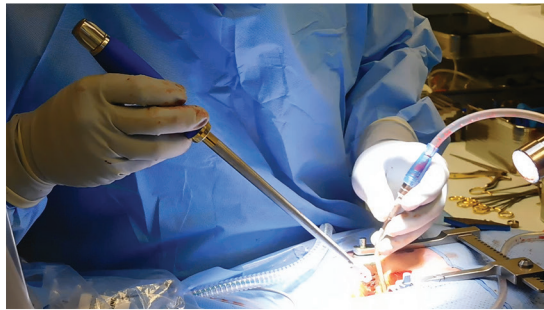

Insert spinal cage into disc space

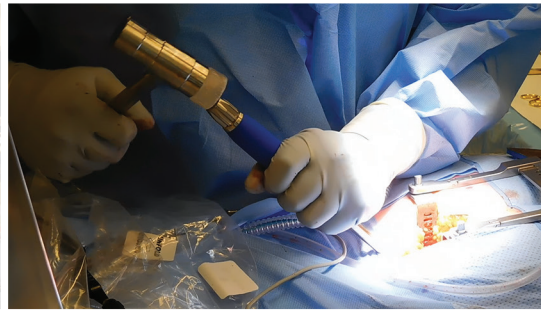

Hammer spinal cage into place



Unscrew spinal cage



Average total completion time: 25 seconds

figure 4.3: Condensed CSSD workflow

A condensed version of the steps which are taken during the sterilization process.

Sterilization

If the applicator is to be reused, it requires disinfection or sterilization. This is either done at a separate company which disinfects and sterilizes the instrument for the hospital, or at the hospital's CSSD. The complete workflow for the CSSD department is shown in appendix B, part 2. A condensed version is shown in figure 4.3. The disinfection and sterilization process consists of several phases:

- Cleaning and disinfecting phase: During this phase, the instruments are checked for any missing parts and put into a washer (figure 4.4) which cleans and disinfects the instrument parts.
- Checks and assembly phase: During this phase, the different parts are checked for completeness, any damages, and instruments which require oil receive fresh oil. Instruments that do not require sterilization, only disinfection, are directly stored and later transported when they are needed.
- Sterilization phase: During this phase, the instruments that require sterilization are prepared for and put into the autoclave or the gas-plasma sterilization machine (figure 4.5).
- Final checks phase: During this phase, the packaging and the sterilization process are checked for errors.
- Storage phase: During this phase, when everything is positive, the instruments are stored and later transported when they are needed.

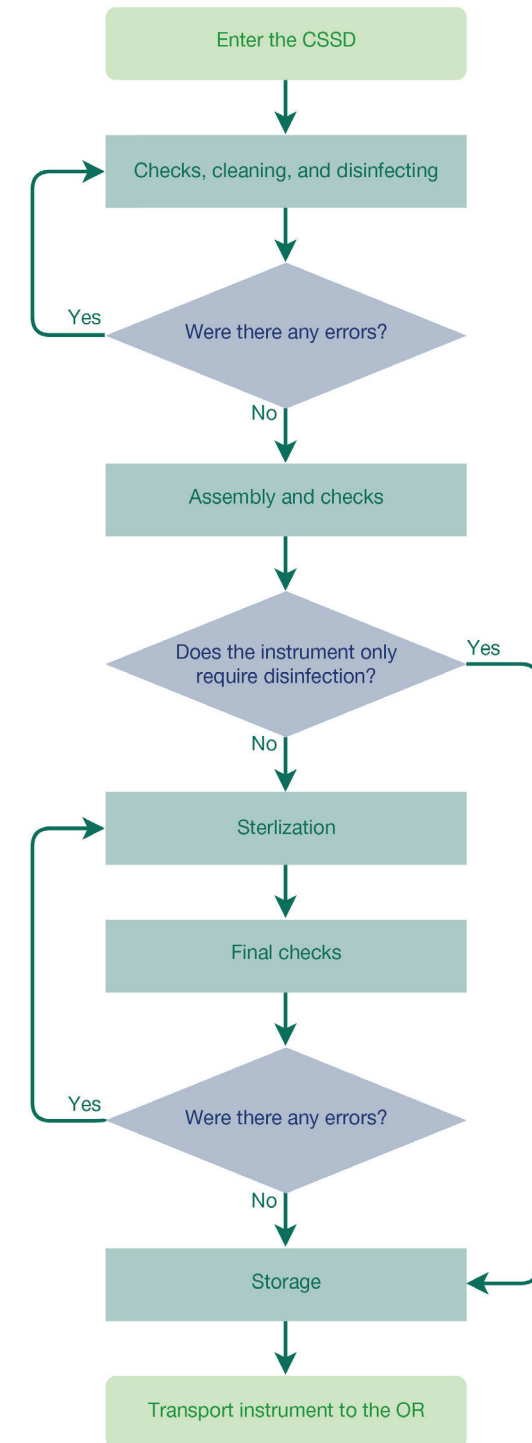

To make the work for the CSSD department as simple as possible a new applicator would have the shortest possible route through the sterilization process, with little as possible chance for error. This is because errors require the instrument to go back a step and be disinfected or sterilized again. An applicator which requires sterilization has to go through all the steps of the process, no shortcuts can be taken. In this case, the workflow can only be improved by reducing the amount of errors which can be made during the process.

A shorter route through the CSSD is possible if the instrument only requires disinfection. This bypasses the steps required for sterilization. The way to reduce the workload the most is by making the instrument entirely disposable. This way the CSSD would have no workload at all from working with the applicator.



figure 4.4: Cleaning and disinfecting machines

These machines clean and disinfect the instruments.



figure 4.5: Sterilization machines

These machines sterilize the instruments

4.3 USERS

From the interviews and observations, an overview of the users of the spinal cage applicator can be created. The primary users of the applicator are: the neurosurgeon, the scrub nurse, and the CSSD employee. Figure 4.6 shows the workflow in the perspective of a reusable spinal cage applicator which is currently used.

Neurosurgeon

The neurosurgeon is the primary user of the spinal cage applicator. This person performs the insertion, and possibly the removal, step using the applicator. To perform these actions, the neurosurgeon requires an applicator which is easy and quickly to use with a high level of repeatability. This is because the surgery needs to be completed quickly and without errors. In an interview (Appendix B, part 3) a neurosurgeon stated that a comfortable grip, clear indications and smooth actions are important characteristics for a proper instrument.

Scrub nurse

The scrub nurse is the secondary user of the spinal cage applicator. This person performs the preparation step for the applicator. To perform this step well, the preparation needs to be quick and easy to complete. This is to avoid any multitasking which could increase the workload for the scrub nurse. The scrub nurse is required to know how the instrument works. This is to be able to assist the surgeon as good as possible.

CSSD employee

There are multiple CSSD employees, working at different stations in that department. Overall, the instrument is handled the most before and after disinfecting. Before the disinfecting, an employee checks to see if the set is complete, and rinses the instruments. To make this task easy, the instrument should be made out of few large parts which are easy to identify. After disinfecting, another employee will perform checks for any damages and completeness. To improve this task, the instrument should be easy to check for damages and should not require any special treatment.

4.4 CONCLUSION

Looking at the workflow of the surgery, the biggest gain can be made in preparing the applicator for insertion. Because of the lengthiness of the current preparation, the scrub nurse has to multitask by handing over instruments to the surgeon as well as preparing the applicator. If the preparation could be made a lot shorter, the scrub nurse would not have to multitask. This makes the workflow for the scrub nurse a lot better. Only small workflow improvements can be made for the insertion step, performed by the neurosurgeon.

When looking at the workflow of the sterilization process, the easiest gain could be made by making a disposable instrument. This eliminates the need for optimising the sterilization workflow. Therefore a disposable applicator design is preferred.

figure 4.6: Applicator perspective workflow

The workflow of a reusable spinal cage applicator system.

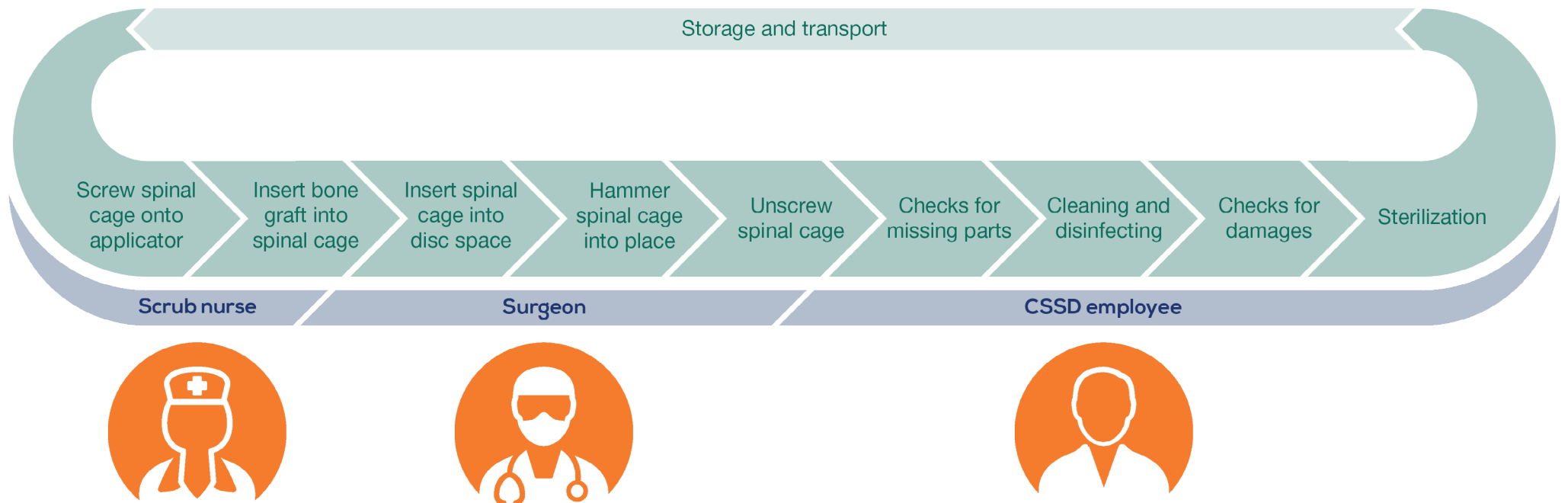

5. RULES AND REGULATIONS

5.1 INTRO

Medical instruments are used in situations where an error or mistake can have a big effect on the health of the patient and possibly the user. These errors or mistakes do not necessarily have to be the fault of the physician operating the instrument, it could also be because of a flaw in the design of the instrument.

To be allowed to handle medical devices in the EU, a CE mark is required. This mark ensures that the device complies to the EU safety, health and environmental standards (“EU-landen: CE-markering | RVO.nl”, n.d.). A CE mark is received if a medical device complies to Annex 1 of the Medical Device Regulation (MDR). The medical device will also need to be classified, the class of the medical device will determine the rigorousness of the assessment procedure for the medical device which may be performed by a notified body (“CE-markering: stappenplan | RVO.nl”, n.d.).

5.2 MDR ANNEX 1

Annex 1 explains that the risk of causing harm to the patient, the user or a third party in any possible way must be minimized. It goes into detail to explain which areas must be covered for any type of medical device. A short summary of all the points which are discussed is given next:

Part 1: General requirements

1. the device should achieve its intended performance.
2. The risk reduction does not adversely affect the benefit-risk ratio.
3. Manufacturers actively take part in risk management.
4. Priority of risk control from highest to lowest: elimination of risk, protection from risk, provide safety information.
5. Priority of use error risk control from highest to lowest: ergonomic related risk reduction, provide training.
6. The use and performance of the device should not harm patient or user.
7. The device should not cause harm during transport or storage.
8. All foreseeable risks should be minimized.
9. All safety requirements are understood.

Part 2: Design and manufacture

This part explains the safety requirements for the following device categories:

10. Devices with chemical properties.
11. Devices intended for microbial interaction.
12. Devices incorporating a medicinal product.
13. Devices incorporating materials of biological origin.
14. Devices intended to interact with other devices.
15. Diagnostic or measuring devices.
16. Devices that provide protection against radiation.
17. Electronic programmable devices.
18. Active devices connected to the previous devices.
19. Active implantable devices.
20. Devices that provide protection against mechanical and thermal risks.
21. Devices that provide energy or substances.
22. Devices that are to be used by lay persons.

Part 3: Information supplied with device

23. Information should be provided which helps to identify the device, it's manufacturer, it's intended use, all relevant regulations, and sterility.

5.3 ISO 14971

A way of minimizing the risk is by conducting a risk analysis. This can be done with the help of the document: ISO 14971 Medical devices - Application of risk management to medical devices ("Medical devices - Groei - European Commission", 2017). This analysis can be done at any point during the design process and helps to make sure every safety aspect of the medical device is evaluated and whether it requires improvement. It should be noted that the use of this document is voluntarily and is not required for receiving a CE mark.

5.4 MDR ANNEX 8

The classification of a medical device is done using annex 8 of the MDR Using this annex it is found that the to be designed spinal cage applicator falls under rule 6 which states: *"All surgically invasive devices intended for transient use are in Class IIa unless they are: "... reusable surgical instruments, in which case they are in Class I"*. Since a disposable design is preferred, the spinal cage applicator will be a class 2a medical device (European Union, 2017). The classification of the to be designed applicator will determine whether a notified body is necessary. A medical device of class 2a or higher automatically requires the use of a notified body.

5.5 CONCLUSION

The classification of the to be designed applicator will be IIa since it will be designed to be disposable. To ensure that the to be designed applicator will be approved by for CE marking, a risk analysis needs to be performed before its market entrance with the help of the ISO 14971 document.

SYNTHESIS

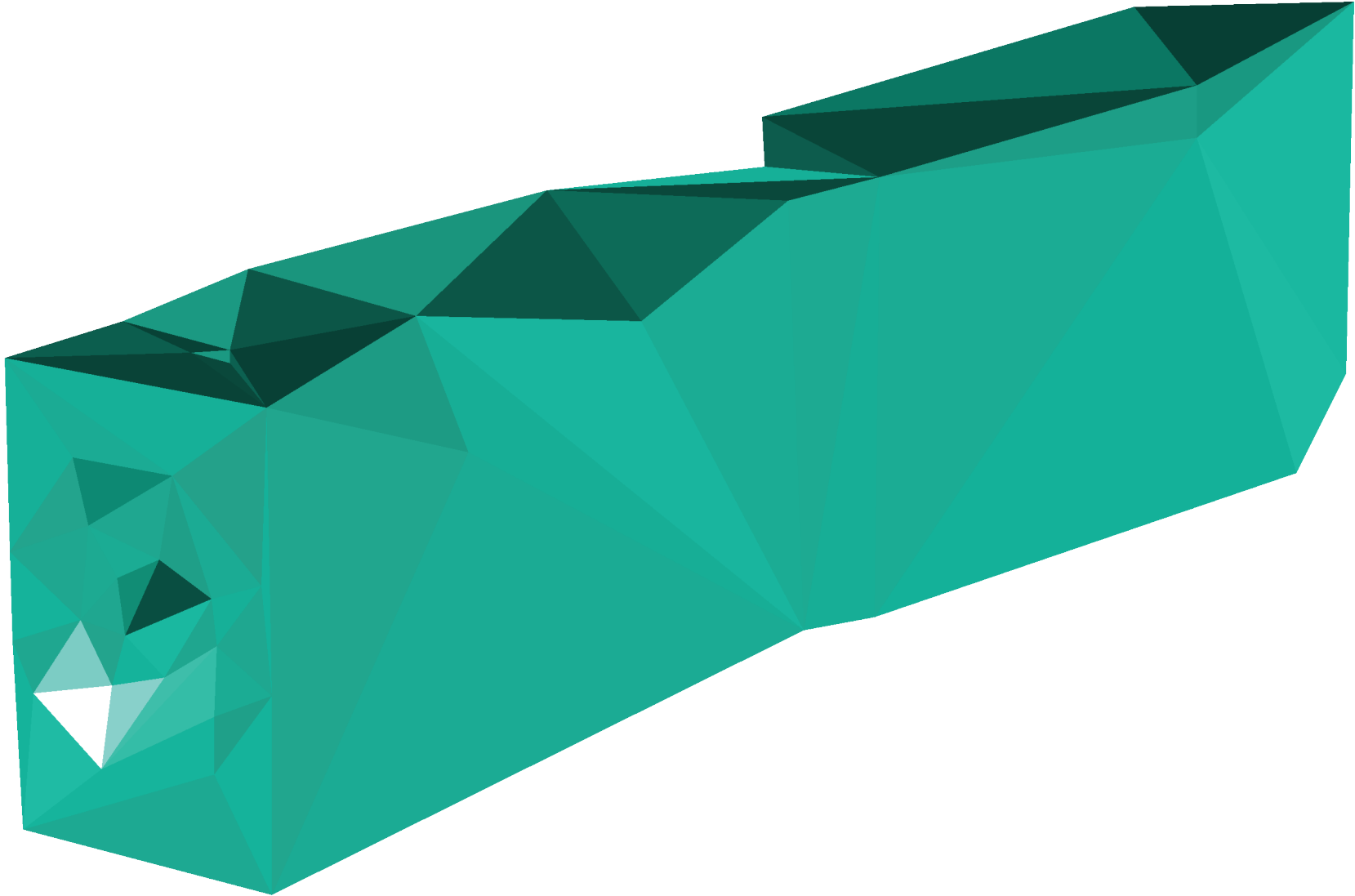

6. DESIGN PROCESS

6.1 IDEATION METHODS

The idea generation process started by using ‘how to’s’ (Roozenburg and Eekels, 2003). These ‘how to’s’ were used to quickly create ideas for solving subproblems which the design would have to overcome. One idea of each ‘how to’ was then taken and used in a brainstorming session where idea sketches were drawn using different combinations of ‘how to’s’. This method is somewhat similar to the morphological chart method (Roozenburg and Eekels, 2003).

The most promising ideas all resembled some kind of syringe-like system (figure 6.1). The ideas use a plunger to propel the spinal cage into the intervertebral disc space. They also have a tube to keep the spring loaded spinal cage in a straight orientation whilst inserting. No complex mechanism is used to translate the input into a force which would propel the spinal cage. These ideas were the most promising since the instruments have the potential to be the most simplistic in their use and construction. This may be beneficial for the workload of the surgeon and may allow the design to easily be translated into either an easy to clean reusable instrument, or disposable instrument.

figure 6.1: Idea drawing

6.2 LEAN STARTUP

A lot of aspects of the product is already predetermined, such as the users, the company or type of institution for which the design will be made, the context in which the product will be used, and it’s function. Taking this into consideration, it was chosen that the lean startup process (Ries, 2011) suited this project the best. The lean startup process focuses on creating an implementable design quickly and on making design iterations in a short design cycle (figure 6.2). This is done by creating a prototype from an idea, testing this prototype, and using the results of these tests to create new ideas for improvements.

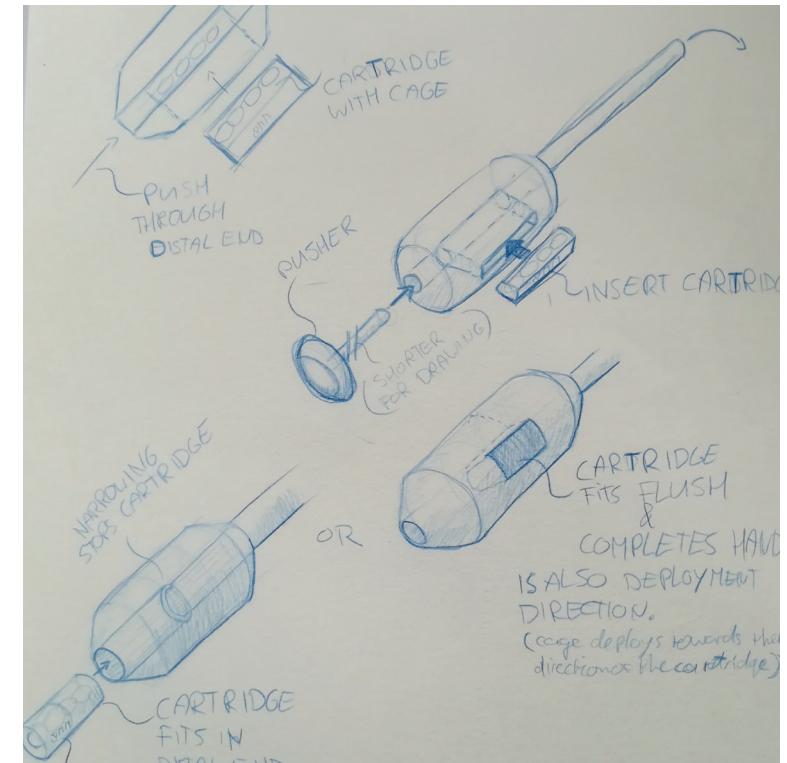

*figure 6.2: Lean startup
process design cycle*

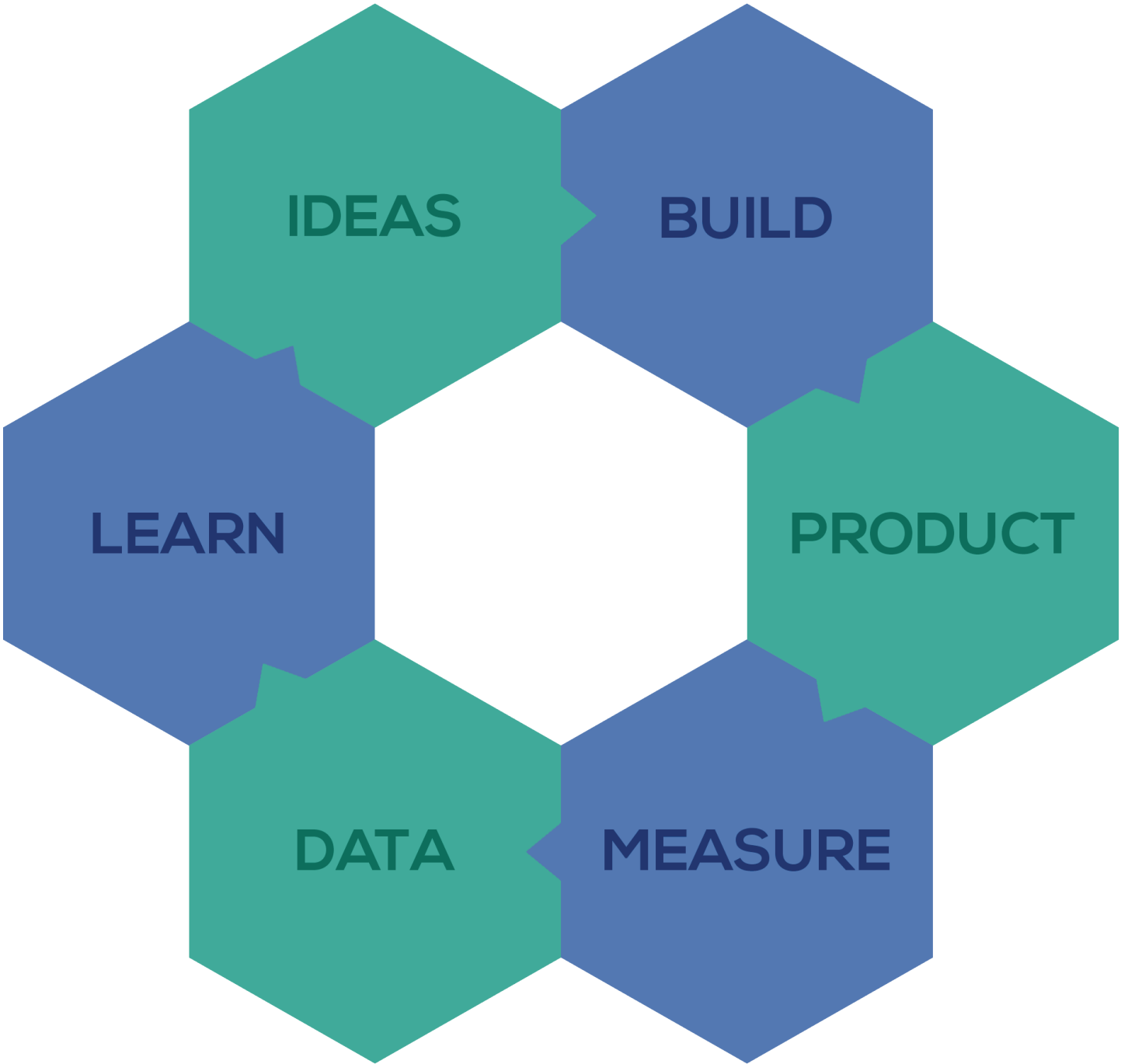

7. DESIGN 1

7.1 DESIGN

The very first prototype was made from the idea of using a simple syringe-like pushing system to deliver the spinal cage into the intervertebral space. The applicator consists of a guide tube, which is at the proximal end of the applicator, and a handle which is at the distal end of the applicator. The guide tube has a square shape so the spinal cage cannot rotate inside the tube whilst the spinal cage is being pushed and inserted. This ensures that the deployment direction of the cage is fixed once the spinal cage is loaded into the applicator, ensuring a correct deployment direction. The handle is hollow and it has a '+' shaped hole going through lengthwise. This is the hole through which the pusher is inserted. The pusher also has a '+' shape, inspired by a disposable syringe pusher. The '+' shape of the hole allows for a stable insertion and avoids rotation and sideways movement of the pusher. The spinal cage is loaded into the proximal end of the applicator, and inserted into the intervertebral space using the pusher (figure 7.1).

7.2 PROTOTYPE

This first prototype was printed into multiple parts in order to fit into the 3D printer. This caused some difficulty in accurately assembling the different parts. The parts are glued together, however the alignment of the parts is not correct. This resulted in a difficult fit for the pusher into the handle. Also, some faces of the parts would not fit correctly due to deformation occurring inside the 3D printer. The affected faces are those which face sideways in the printer. The top and bottom faces had no trouble with deformations and fit well. Because of this, the handle could not be fixated onto the guide tube and the pusher could not be completely assembled. This resulted in a decision to leave out the handle as the prototype would function more or less the same as the initial design. No real test was performed with this prototype. However, it did give a good insight on where improvements should be made (Appendix C, Design 1).

7.3 CONCLUSION

The design requires improvement in the following areas:

- The spinal cage is falling out of the proximal end of the applicator;
- The guide tube can be made to fit the spinal cage much tighter. This reduces the field of view which is blocked by the applicator, and it increases the control over the applicator in a MIS situation since the applicator will have a greater movement inside the tubular retractors;
- The cage cannot be removed from the intervertebral space using the applicator;
- The pusher has a difficult fit into the applicator. However, this is probably due to some errors made during the assembly of the parts and has less to do with the actual design;
- Inserting the spinal cage in the applicator can be tricky due to the elastic properties the cage hinges.

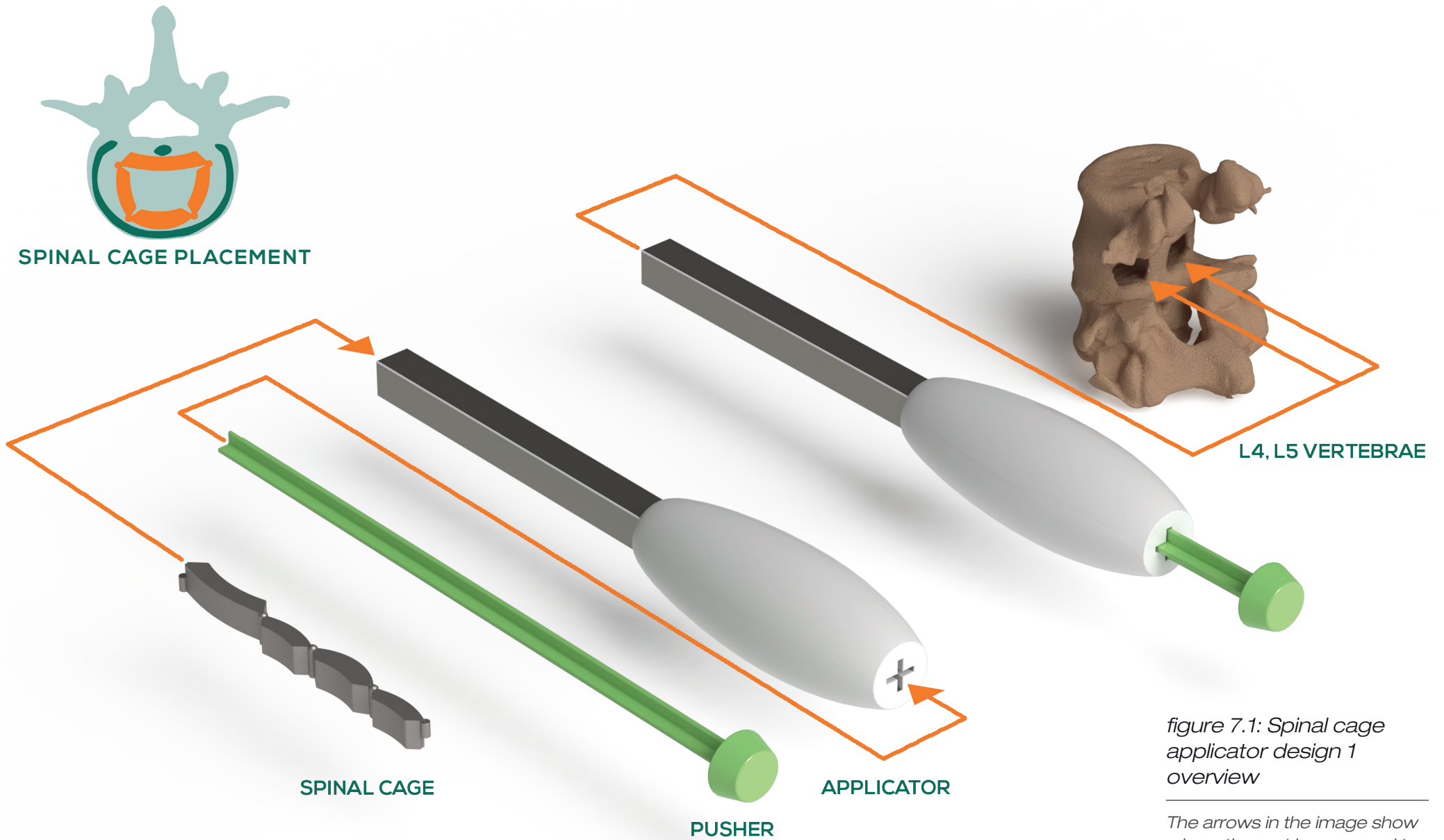

figure 7.1: Spinal cage applicator design 1 overview

The arrows in the image show where the part is supposed to be inserted before use.

8. DESIGN 2

8.1 DESIGN

The second design improves on the errors of the first prototype by incorporating a cartridge system, using a connecting mechanism between the pusher and the spinal cage, and some changes to the overall dimensions so all the parts have a tighter fit. This is done to save space. Since no handle design is chosen yet at this point, a cylindrical handle with the minimal comfortable dimensions according to van Veelen, Jakimowicz and Kazemier, (2004) was made. The prototype was made shorter to ensure that the design would fit inside the Ultimaker 2+ 3D printer.

Cartridge

The cartridge is incorporated to reduce the preparation time of the applicator for the scrub nurse, and to ensure that the spinal cage would not fall out of the applicator when handling. Small flaps on the two ends of the cartridge will keep the spinal cage from falling out of the cartridge, and ensure the user can exert enough force to make a good connection between the cage and the pusher. These flaps are also able to bend outward when enough force is exerted, allowing the spinal cage to move through the applicator. To make sure the small flaps don't block the path of the spinal cage, a small alcove is made inside the applicator which provides space for the flap to bend into, away from the path of the spinal cage.

The label on one end of the cartridge is there to ensure the cartridge can be removed from the applicator. The label also allows for some markings, indicating the proper manner of insertion into the applicator and whether the spinal cage is oriented for insertion into the left or right opening of the intervertebral disc.

Connection mechanism

The connection between the spinal cage and the pusher (figure 8.1) has two functions: to give the surgeon more control when inserting the cage, and to allow the surgeon to remove the spinal cage with the same pusher should this be necessary. The connection is made to be quick and simple to use. A twist-lock mechanism was chosen for this reason and because this mechanism can be made very small.

*figure 8.1: Spinal cage,
pusher connection*

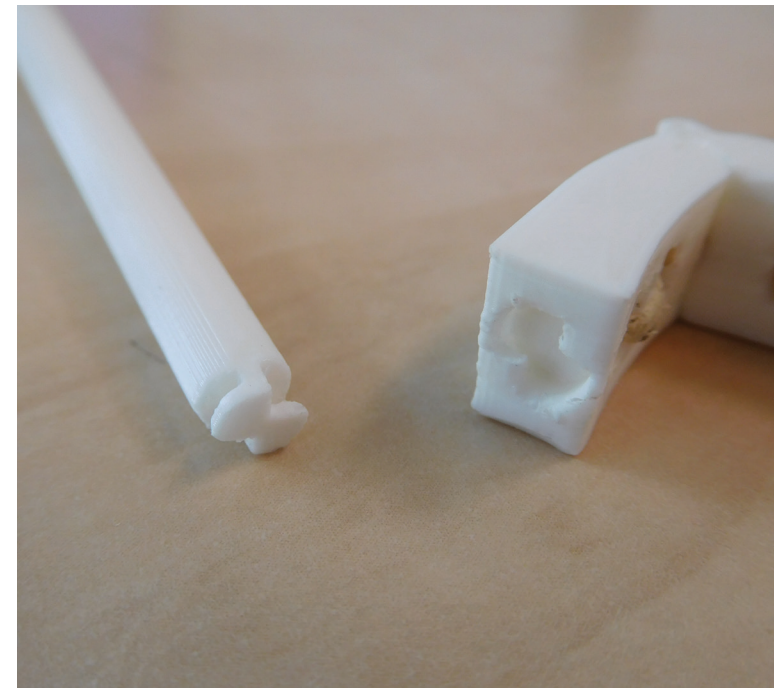

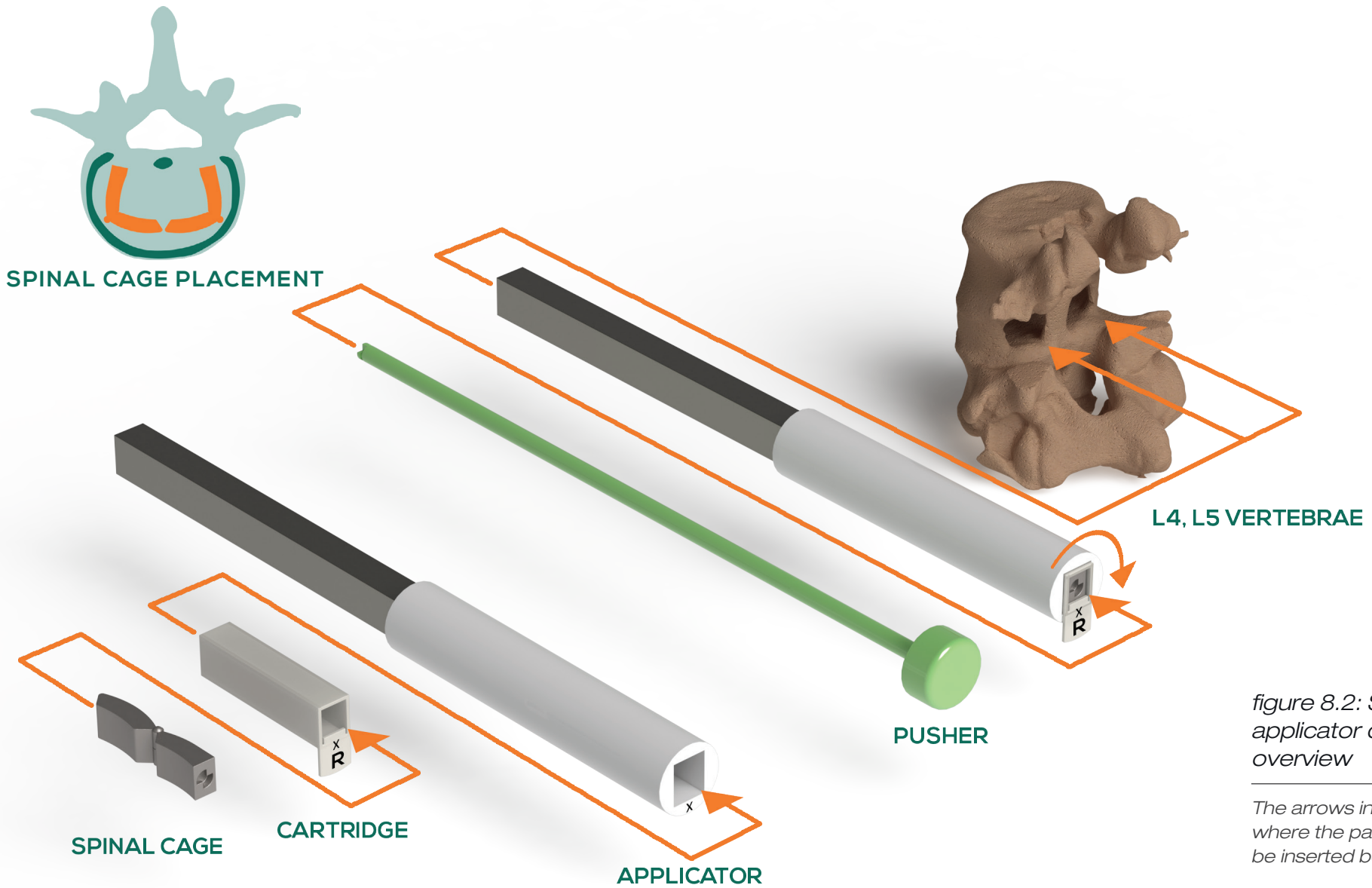

figure 8.2: Spinal cage applicator design 2 overview

The arrows in the image show where the part is supposed to be inserted before use.

figure 8.3: Design 2 prototype

8.2 PROTOTYPE

This prototype (figure 8.3), just like the previous version, is made using the Ultimaker 2+. The applicator is printed in two halves, split lengthwise. This is to make sure the shaft of the applicator is smooth and does not contain support material and is straight without variable dimensions along its length. The cartridge, cage and pusher are all printed in one piece. To ensure the applicator would not require too much assembly, causing errors, the length of the device was reduced so it would fit into the Ultimaker 2+ building box (appendix C, Design 2).

8.3 TEST

To test the usability of this design, a setup (figure 8.4) was created to mimic an open and MIS surgery (Appendix D, part 1). The test subjects were asked to perform 8 runs which contain 3 steps: preparing the applicator, inserting the spinal cage, and removing the spinal cage. 4 of these runs were in the open configuration, and 4 in the MIS configuration. All the steps were timed. The reasons for so many runs was to get closer to the time of a more experienced user. The first 2 open and first 2 MIS runs were done without explanation of how the instrument worked. Then the final 4 runs were performed with the explanation of the applicator's intended use. Afterwards, the participants were interviewed about their experience and thought about the applicator. The entire test was video recorded.

figure 8.4: Test setup

figure 8.5: Deploy direction explained

The arrow indicates the direction to which the spinal cage hinges when exiting the applicator: the deploy direction.

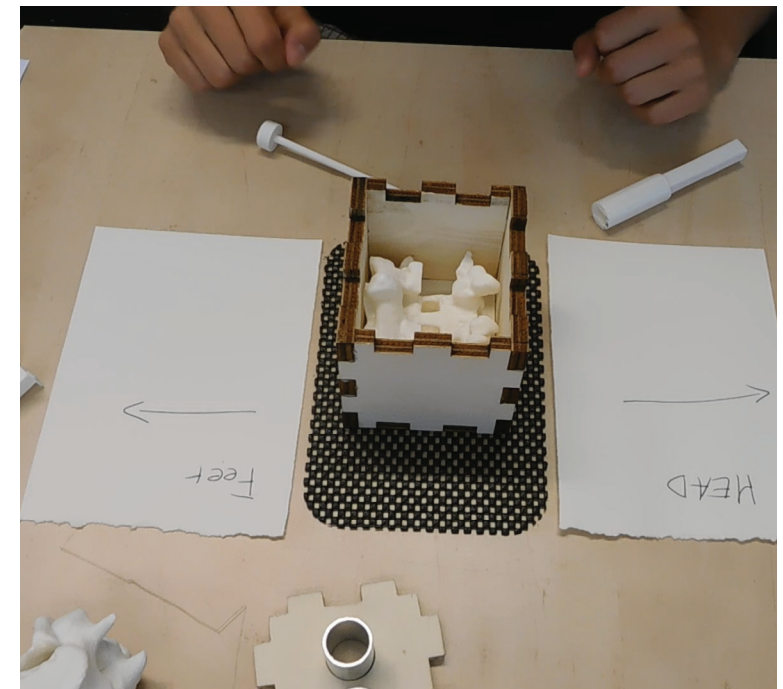
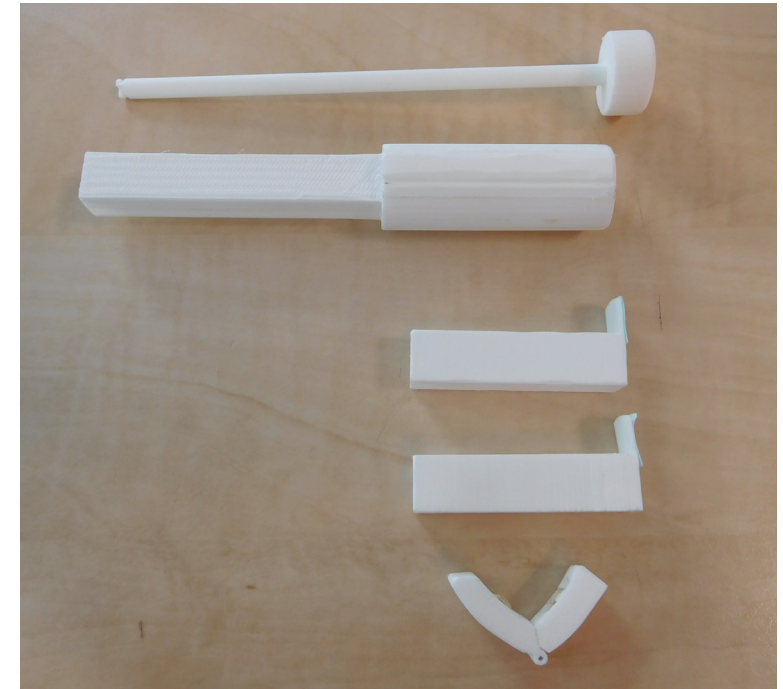
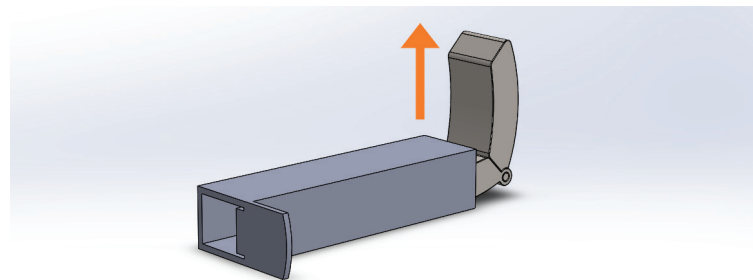

8.4 RESULTS

The observations and participant statements can be summarized in the following categories:

Insertion and orientation

The orientation is found to be confusing by some participants. Some participants let the cage stick out a bit before insertion, to get a better feeling for the deploy direction (figure 8.5). Otherwise, the insertion was mostly performed without errors.

Preparation

Almost no errors were made in preparing the applicator, and the preparation is done quickly.

Removal

The cage easily disconnects from the pusher. Participants tend to hold the pusher with a precision grip during removal.

Vision

The participants state that the vision on the target is poor in the minimally invasive setup.

Markings and feedback

The markings on the cartridge are found to be unclear, even after multiple uses. The participants expressed a lack of markings which indicate the deployment direction of the spinal cage, and rotation direction to make the connection between pusher and spinal cage, however the rotation direction is found to be intuitive.

Performance

The participants stated that the applicator is easy to use and easy to learn. The insertion and preparations are quicker than the times recorded during the PLIF observations.

8.5 CONCLUSION

It is found that the design is easy to learn and intuitive to use. Also, the times required to complete the steps of preparing and inserting the spinal cage are better when compared to the times observed at the PLIF operations. The main problems with the usability of the instrument comes from difficulties in finding the right orientation when inserting the spinal cage. This is caused by unclear marking on the cartridge and the lack of markings for the connection mechanism. The points of improvement which were found are:

- The orientation of the instrument and its parts should be immediately clear for:
 - Preparation of the applicator;
 - Insertion of the spinal cage;
 - Left and right vertebral disc space opening;
 - Deployment direction of the spinal cage.
- Facilitate a precision grip handle on the pusher;
- Improve the vision of the surgeon on the surgical area in the MIS setup;
- Make the connection between the pusher and spinal cage more secure, so the connection does not release as easily;
- Improve feedback between the pusher and spinal cage:
 - Indicating the correct rotation direction;
 - So the user knows that the spinal cage is connected correctly.
- Make the pusher move less from side to side when inside the applicator;
- Make it easier to find the connection on the spinal cage with the pusher;
- Make it easier to find the opening in the intervertebral disc.

figure 9.1: Cartridge design 3, tear through layer detail

9. DESIGN 3

9.1 DESIGN

This third design (figure 9.3) further improves the applicator design by incorporating the lessons learned from the previous models. To validate which design details should be incorporated into the new design a test was conducted (Appendix E). In this test variations of the connection mechanism between pusher and spinal cage were tested, along with variations of precision grips, and orientation aiding symbols. The most preferred variations are incorporated into this third design. Changes were also made to how the cartridge stops the spinal cage from moving down the applicator on its own, and to the dimensions of the applicator.

Cartridge

The design of the cartridge was changed to make the correct orientation more clear, and incorporates an updated blocking mechanism (figure 9.1). The shape of the label on the cartridge is pointed in one direction. On this label, an arrow is printed which points in the same direction to add clarity to its direction indicating purpose (figure 9.2). This design was the most popular in the detail test. The shape and arrow point in the direction towards which the spinal cage will deploy. For a proper insertion, the arrow should always point towards the midline of the patient when inserting. The label is now the same for insertion in the left opening of the intervertebral disc space as for the right. This removes the resources required to make different cartridges for the left and right opening.

The new blocking mechanism is based on a tear-through layer which hinges open like a small trap door. This allows the spinal cage to pass through only when enough force is applied to the blocking mechanism.

figure 9.2: Cartridge design 3, label detail

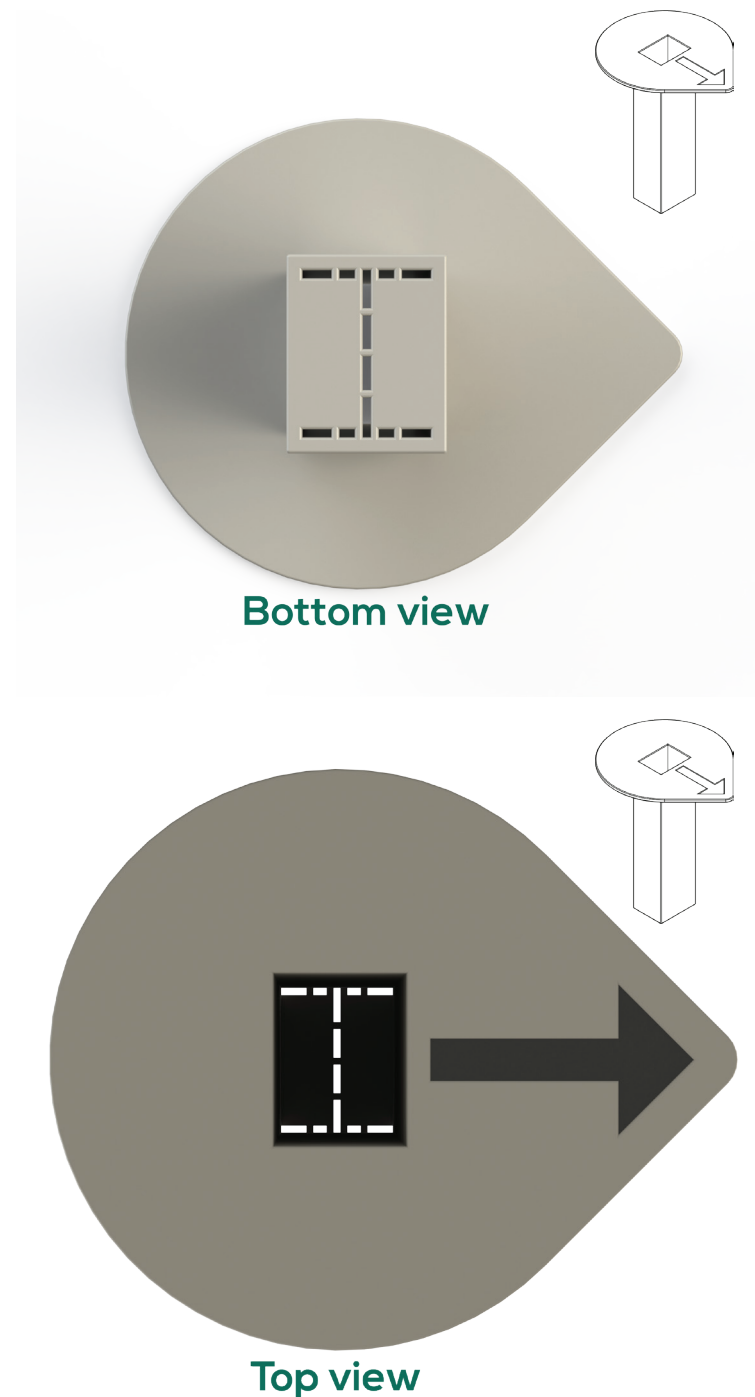

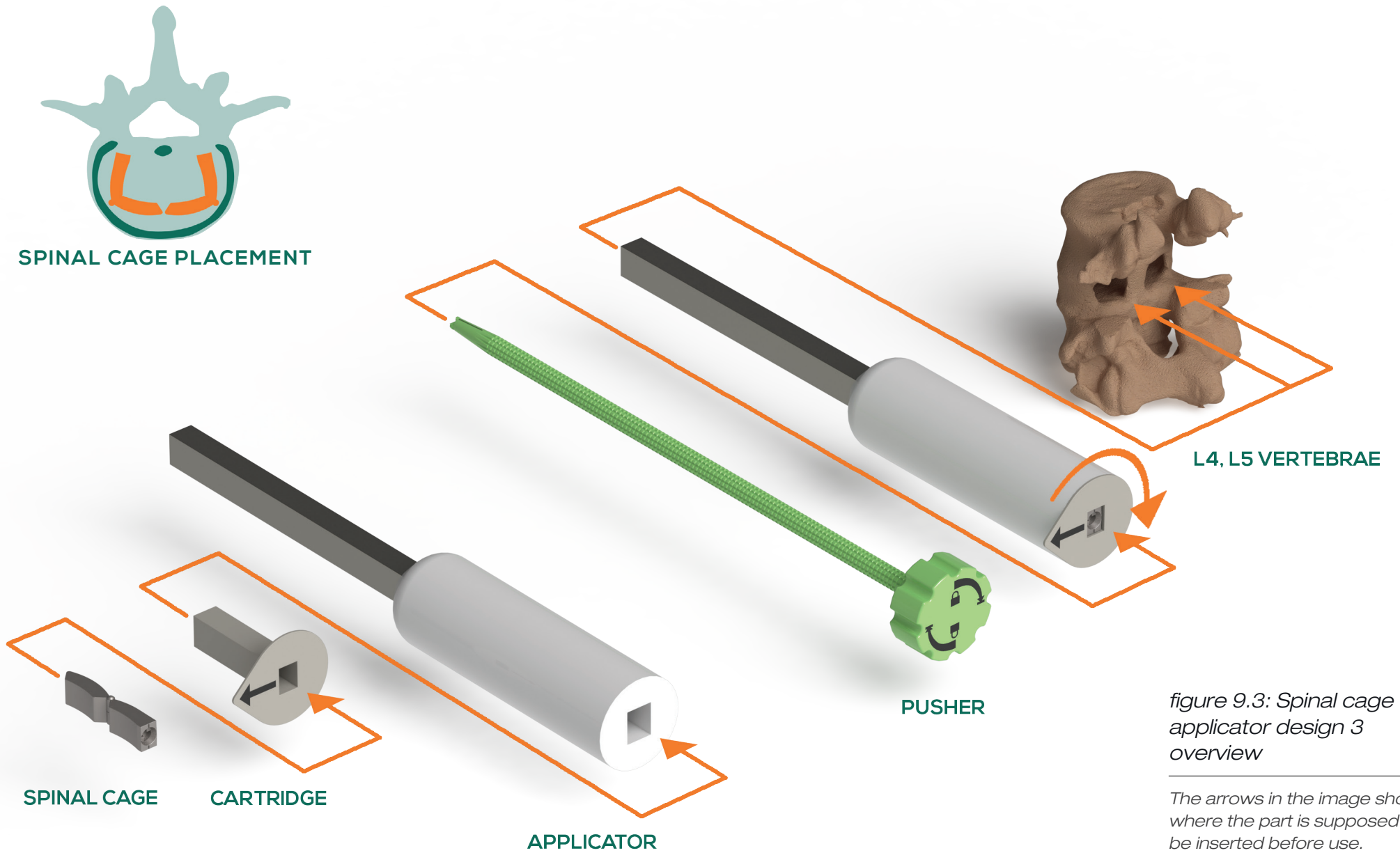

figure 9.3: Spinal cage applicator design 3 overview

The arrows in the image show where the part is supposed to be inserted before use.

figure 9.4: Pusher design
3 knob detail

Pusher

The pusher is redesigned to have a larger diameter which allows for a more comfortable precision grip. It also has a grip pattern (figure 9.5) for extra grip when wearing gloves and when there is blood or mucus on the pusher. The pusher has an updated geometry for the spinal cage connection which allows for a more secure connection, and it has several markings which help determine the rotation direction for locking and to help align the pusher and the spinal cage.

figure 9.5: Pusher design
3 grip detail

The rotation knob has grooves along the outer surface to give the surgeon extra grip while rotating the pusher. The markings on the knob were the result of a short brainstorm session which ended in several designs. The designs were presented to 10 persons. The design presented in figure 9.4 is the one which was chosen as the best.

The implemented grip pattern and cross section of the pusher was chosen as the most comfortable when rotating, while providing the most grip. The participants could choose from a square, hexagonal, and round cross section. The participants could also choose between a smooth surface, grooves perpendicular to the length of the pusher, and grooves both lengthwise and perpendicular to the length of the pusher (figure 9.5).

figure 9.6: Pusher design
3 connection detail

The geometry of the connection mechanism (figure 9.6) was chosen above other designs because this design provided the most secure connection and the best feedback from the possible selections (Appendix E). The marking was added later, to aid in lining up the connection with the spinal cage.

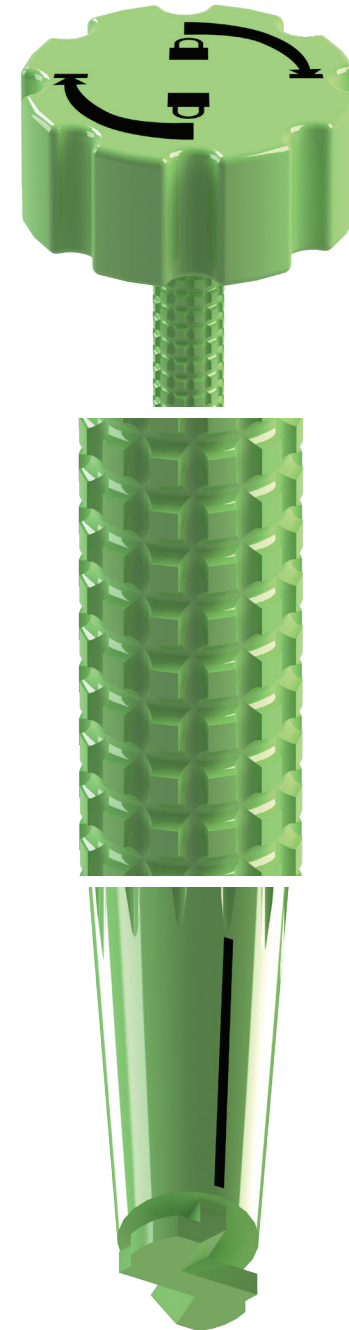

Spinal cage

The connection on the spinal cage is changed to aid in make a good connection quickly. The connection is positioned deeper now, with a tapered opening which guides the pusher towards the actual locking mechanism. The spinal cage also has markings which align with markings on the pusher to help lining up the connection properly (figure 9.8).

The deepened connection with the tapered opening was chosen above a regular connection, located directly at the surface, since the participants stated that it greatly helped to guide the pusher into making the connection. The markings were added later to further aid in lining up the connection properly.

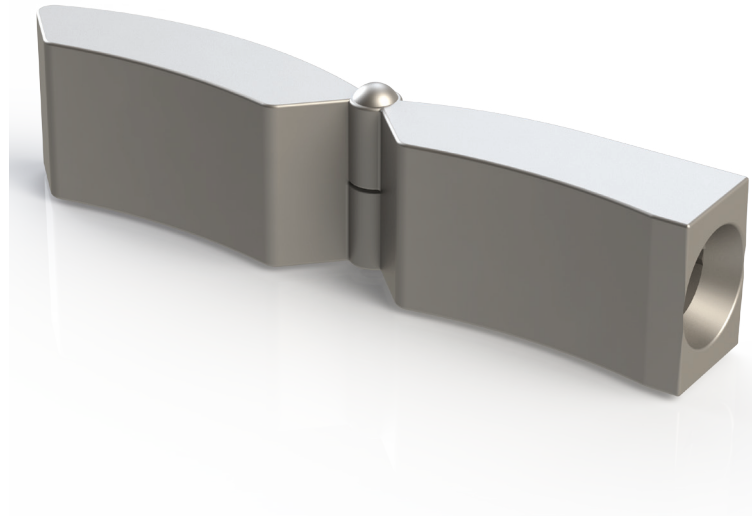

figure 9.7: Spinal cage design 3 overview

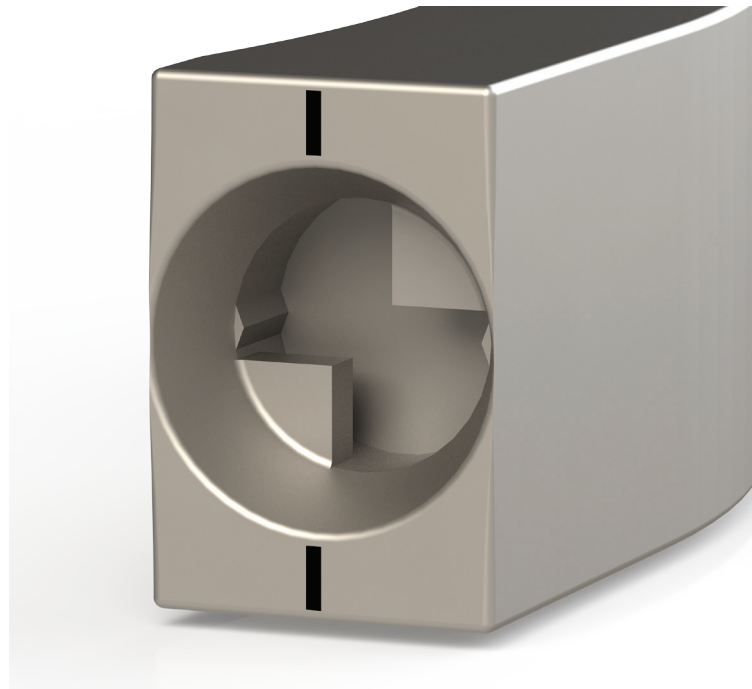
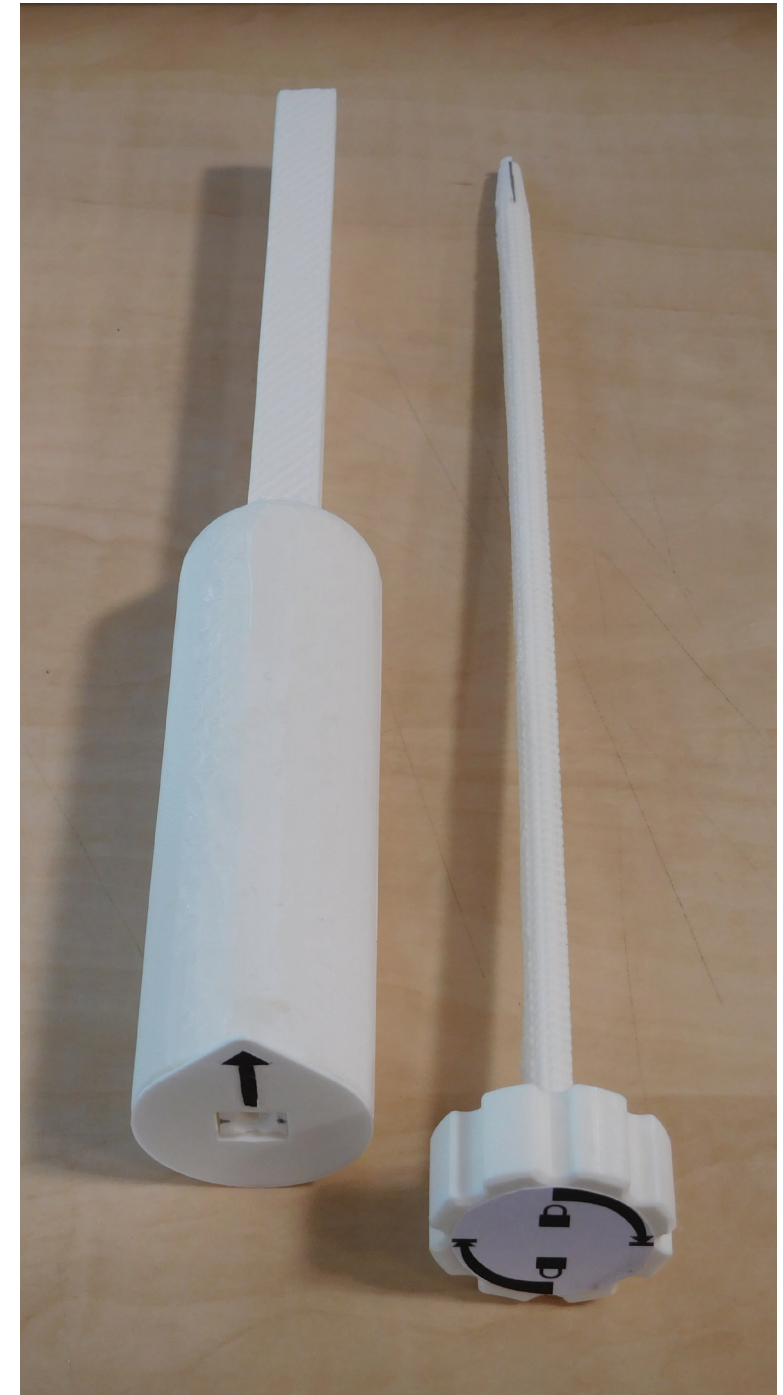

figure 9.8: Spinal cage design 3 connection detail

figure 9.9: Spinal cage
applicator design 3
prototype

9.2 PROTOTYPE

This prototype (figure 9.9) was also made using the Ultimaker 2+ 3D printer. The applicator was also printed in two halves, like the previous prototype. It barely fits diagonally into the printer. The pusher had to be printed into two parts which had to be glued together. The tear through layer on the cartridge was created by printing only one single layer of material. This layer had to be printed first and the resulting orientation of the print caused it to require a lot of support material for the rest of the cartridge. The spinal cage was printed and constructed in the same way the previous ones were. The only difference was the use of another type of rubber band which is a lot thinner. This reduces the chance of unwanted friction when inserting the spinal cage. The markings on the pusher, cartridge and spinal cage were created by glueing paper prints onto the parts and drawing lines with a fineliner pen onto the parts (Appendix C, Design 3).



9.3 TEST

To evaluate the third design iteration, a user test was conducted with neurosurgeons, students and med students as participants. The test was conducted on a test setup which better simulates a surgical setup, compared to the design 2 test setup (figure 9.10 and 9.11). The goal of this test was to measure the workload of the participants and gain some usability insights. The physical workload was measured through an EMG device connected to the flexor digitorum, which flexes the fingers, and thenar muscles, which flexes the thumb. Stress levels were measured using a heart rate monitor. After the test was conducted the participants were asked to fill in a NASA-TLX form to measure the perceived workload. They were also asked to perform a retrospective think aloud. During the test the participants are asked to insert and remove the spinal cage using the applicator prototype. These steps are timed and errors are counted. The steps were repeated for a total of four times to emulate the times of a more experienced user. The insertion time was compared to the insertion time measured during the surgery observations as a reference (Appendix B, part 6 and 7). Quick insertion and preparation times were preferred since a surgery needs to be completed quickly. The full test report can be found in appendix F.

The test was performed on 4 participants: 2 non-med students, 1 med student, and twice with the same neurosurgeon. The neurosurgeon performed the test twice to double the available data from an actual neurosurgeon, since very little surgeons were available for this test.



figure 9.10: Test setup overview



figure 9.11: Video camera perspective of participant performing test

The test participant is connected to an EMG monitor (electrical wires connected to the right arm), and a heartrate monitor (wristband on the left arm).

figure 9.12: EMG data of surgeon A

Image shown on right page.

9.4 RESULTS

Timing and errors

The time it took to perform the insertion step was comparable with the times observed in the PLIF surgery. The non-med students are the slowest to perform the steps, and both made two errors. The surgeon was second fastest and made zero errors during the first test, and two errors on the second test. The med student performed the steps in the shortest amount of time and made one error. All the errors were made during the insertion of the spinal cage.

NASA-TLX

The NASA-TLX indexes for each participant are:

- Student A: 37 out of 100
- Student B: 40,33 out of 100
- Med student: 41,33 out of 100
- Surgeon A: 10 out of 100
- Surgeon A2: 27,17 out of 100

The NASA-TLX score indicate a low to moderate difficulty and workload for the use of the applicator. The surgeon expressed the lowest workload.

	Student A	Student B	Med student	Surgeon A	Surgeon A2
Average HR (BPM)	101	68	85	109	94
HR max	191	188	188	180	180
% of HR max	53	36	45	60	52
Exercise level	Very light	Rest	Rest	Very light	Very light

Heart rate

The heart rates for all the participants are moderate to low (figure 9.14), except for the peak heart rate of surgeon A, who has a momentarily high heart rate of 162 BPM.

EMG

The EMG data (figure 9.12, 9.13) shows higher tension in the thenar muscles when the applicator was used. The calibration with the grip force meter shows that during use, the thenar muscles experience around the same tension as the medium (20 kg) grip force, with some peaks similar to the tension for high (50 kg) grip force. The flexor digitorum experienced tension between low (10 kg) and medium (20 kg) grip force. It should be noted that only the EMG data of the neurosurgeon is available since the EMG recorder malfunctioned with the other measurements.

figure 9.13: EMG data of surgeon A2

Image shown on right page.

figure 9.14: Heart rate data

EMG data surgeon A

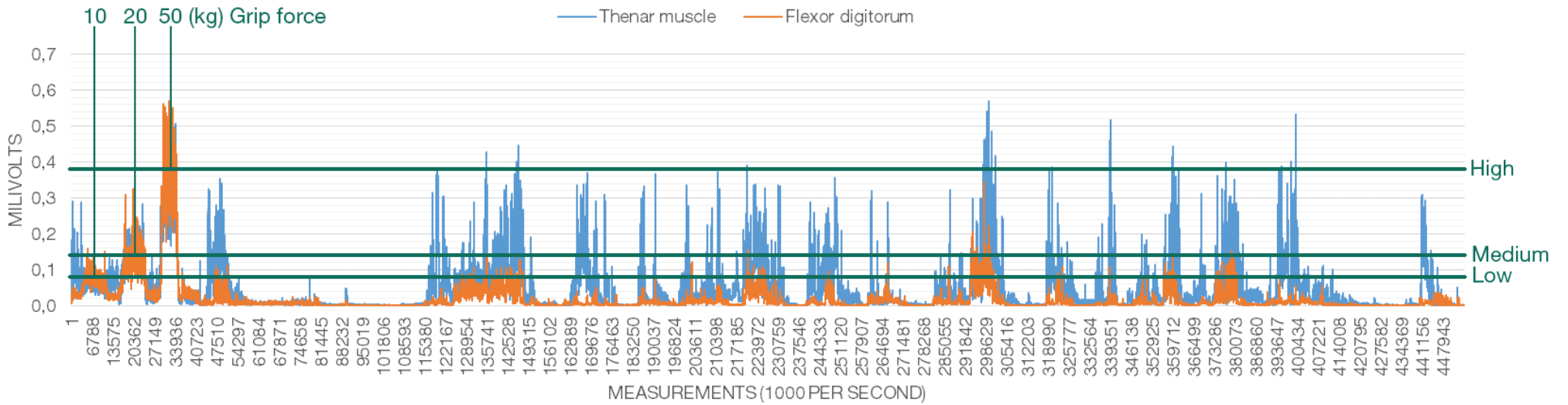

EMG data surgeon A2

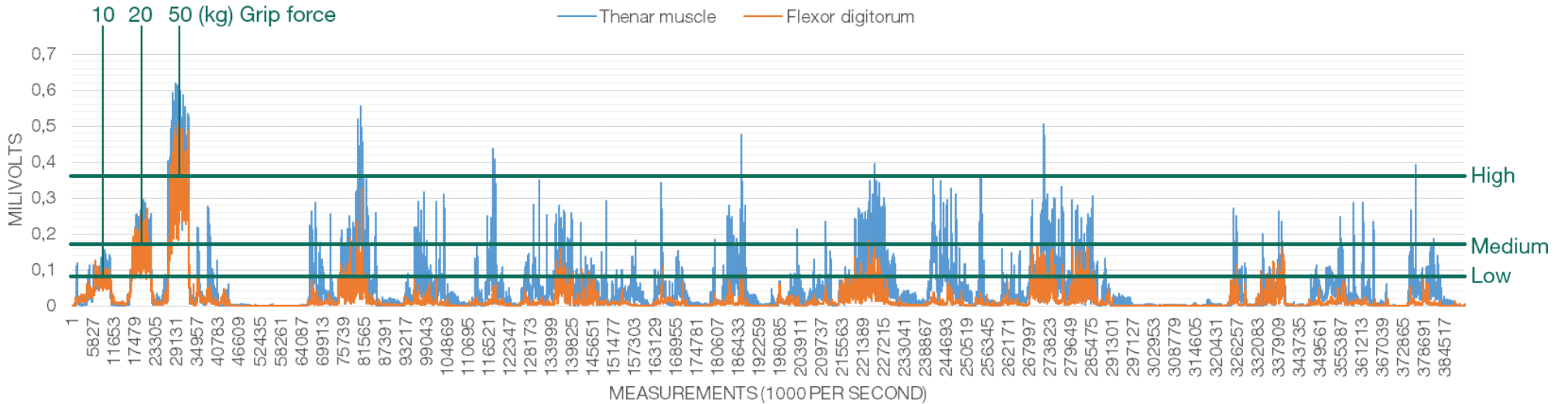

Retrospective think aloud

In the retrospective think aloud sessions, the participants had trouble seeing the target where the spinal cage had to be inserted, and did not always experience enough feedback to ensure a correct insertion.

Also, the insertion action of the prototype is described to be rough at times. This reduced their confidence and may increase stress and workload, possibly having an effect on the NASA-TLX score.

Another point which was addressed was the connection between the pusher and the spinal cage. If the connection with the spinal cage is lost, the connection is difficult to re-establish. This is because the connection can only be made when the pusher and spinal cage are perfectly in line, but the hinging action of the spinal cage may divert the spinal cage away from this alignment when the connection is lost.

It was noted that the tear through blocking mechanism may release harmful particles into the patient's body when used.

The overall opinion on the applicator was positive. The participants stated that the applicator is very easy and clear to use.

figure 9.15: Instrument overview and knob detail

9.5 ANIMAL TEST

M.Ahmadi, who works on the design of the spinal cage, performed an animal test to evaluate the performance of the spinal cage. In this test, a spinal cage was tested on a dog. The spinal cage used in this test was inserted using an instrument design similar to the pusher of this graduation project. The instrument used in that test was made from stainless steel, using milling and turning. The connection geometry is highly similar to the geometry of the connection of design 2 (figure 9.15, 9.16, 9.17).

The surgeon who performed the surgery, expressed that the instrument worked well, and expressed an overall positive attitude towards its use and the connection method. This feedback is valuable for the evaluation of the design of the pusher.



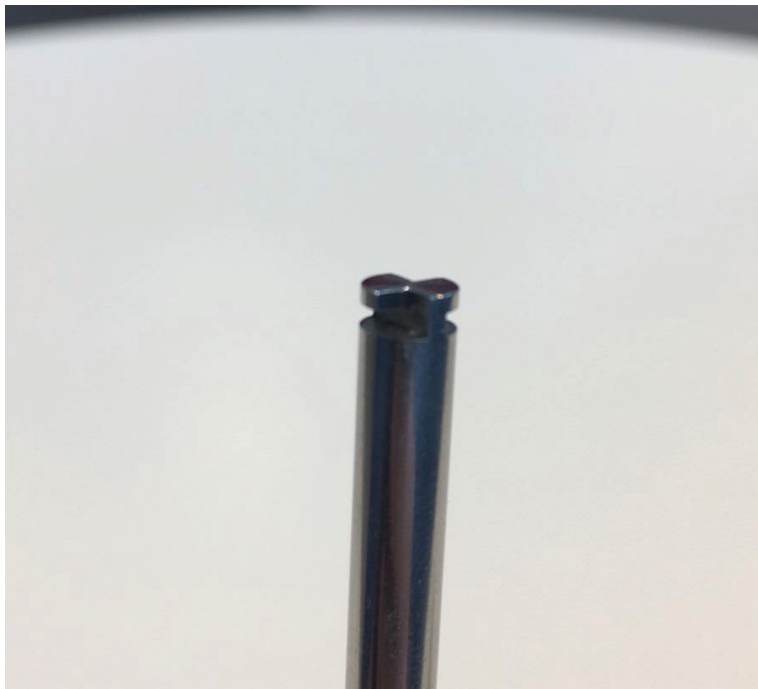

9.6 CONCLUSION

The test data and feedback from the participants showed that the current applicator design invokes a low to moderate workload and stress during use. This is positive for the development of the applicator. The amount of mistakes which are made still needs to be brought down, as mistakes during an actual surgery may cause serious harm to the patient. Using the test data and the participant's feedback, the following improvements are proposed:

- The connection between the spinal cage and applicator is to be made more rigid. At the moment it is easy to lose and hard to re-establish connection if the insertion is challenging;
- Increase the visibility on the target opening in the intervertebral disc space;
- Create a more smooth action when pushing down the spinal cage;
- Improve feedback to know if cage is placed correctly, before releasing;
- Change the blocking mechanism to remove the chance of harmful particles entering the patient's body.

The animal test performed by M. Ahmadi showed that the pusher design works well, and that the surgeon who used the instrument has positive feelings towards the design. This is a valuable evaluation of the design, which can be used to support the design.



figure 9.16: Coonection detail 1

figure 9.17: Connection detail 2

DETAILING

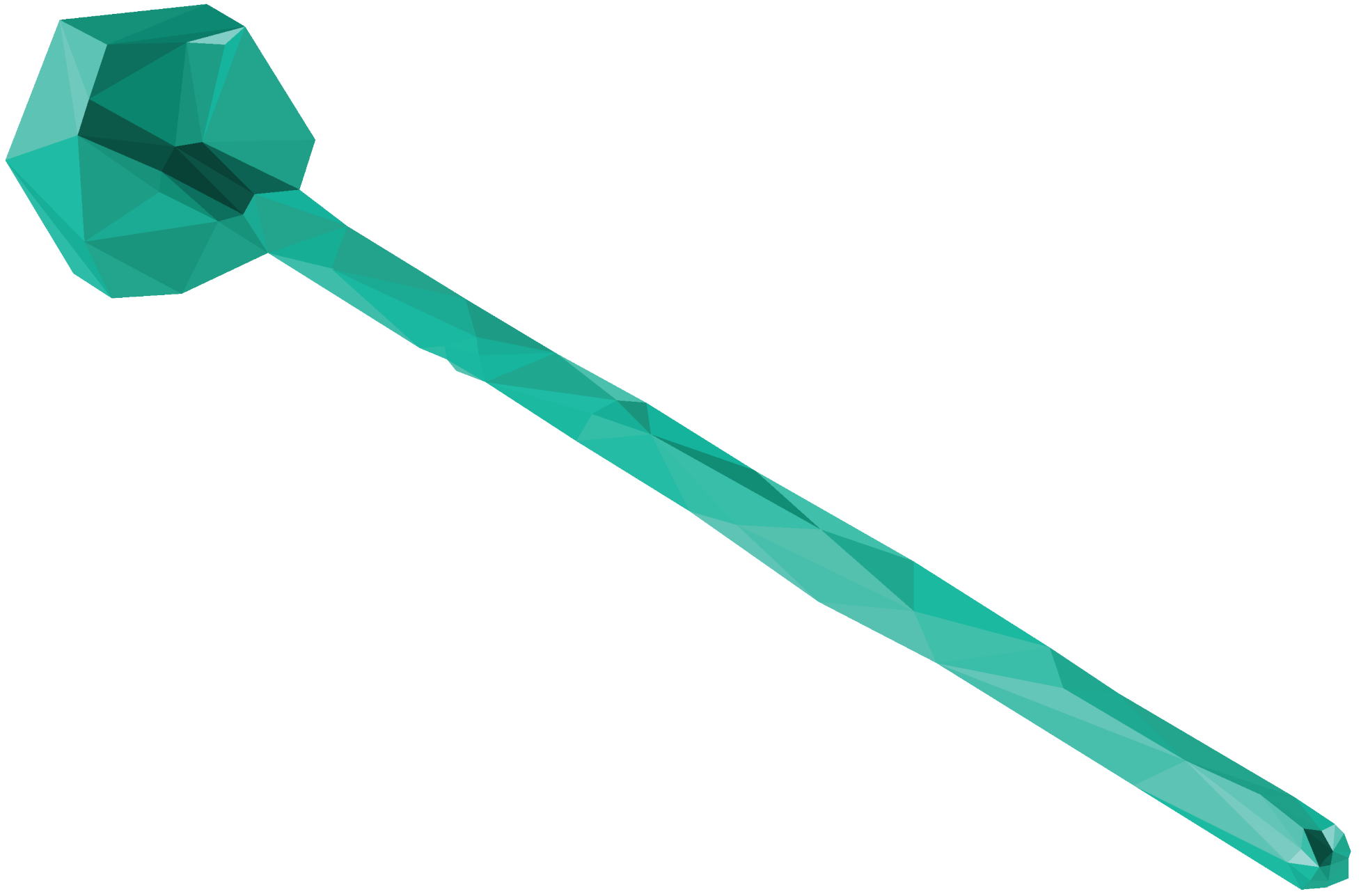

10. MATERIALS

10.1 INTRO

The following part will present the material selection process. Since the spinal cage applicator is made to be disposable, a large batch size is expected, therefore the manufacturing should be cheap and suitable. With this in mind, it is decided to use mostly plastics for the parts. For producing the plastic parts, the injection molding process will be used. Only the pusher will not be made from plastics, due to the forces exerted on this part, so the pusher will be made from some sort of metal.

10.2 BATCH SIZE

For the large batch size, a properly chosen production method and materials are required. In a PLIF surgery, two spinal cages will be used, while there is only need for one applicator. The estimated batch size for the spinal cages are 10.000 pieces annually, which means the batch size for the applicator will be 5.000. With this estimated batch size in mind, the proper materials and production methods are to be chosen.

10.3 PLASTICS

Criteria

The plastic which will be used requires to be suited and approved for medical applications. To create a consistent using experience for the surgeon, and to create a better fit between the different plastic parts, dimensions and tolerances are preferred to have little variability. This results in a preference for a plastic with low linear mold shrinkage. After the product is manufactured, the device will be sterilized using a gamma ray sterilization process. Since the applicator is made to be disposable, the material price should be low. When using the applicator, the surgeon desires a good view of the target insertion area. The use of a clear plastic can reduce the area which may be blocked by the applicator, and allows the surgeon to better track the insertion of the spinal cage. The tube of the applicator is long and thin. A plastic with a high yield strength reduces the change of structural failure, due to unintentionally applied forces. After the use, the applicator will be disposed of. Most disposable medical devices are disposed on a landfill (Sastri, 2010), which is why there is a preference for biodegradable plastic.

figure 10.1:Plasticsmaterial criteria



Medical grade

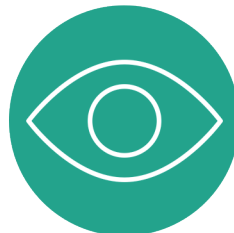

Transparent



Gamma radiation
sterilizable

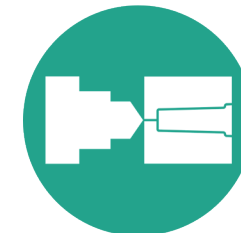

Suited for
injection molding



High yield
strength

Available plastics

A selection of possible plastics is made using the Cambridge Engineering Selector 2017 (CES) together with the previously determined criteria. The results of these plastics are shown in the table (figure 10.2) below, taking all required aspects into account.

Conclusion

Together with feedback from a materials expert of the TU Delft, E. Karana, it is decided to use a low viscosity grade of polycarbonate (PC, low viscosity). This material is chosen because it is already often used for similar types of medical devices. Another reason for choosing this material is because of its optical quality transparency. Of the materials with the same level of transparency, this material has the highest yield strength and excellent compatibility with injection molding. The only downside of this material is the relative costs to the other materials. However, the safety of the patient is more important than the cost of the applicator. Therefore the strongest material, with the best transparency, and the best producibility is chosen.

figure 10.2: Plastic materials

Material	Biodegradable	Injection molding	Linear mold shrinkage (%)	Medical grade	Transparency	Price (€/kg)	Sterilizability	Yield Strength (Mpa)
ABS	No	Excellent	0,9 - 6,7	No	Transparent	2,15 - 2,54	Good	32 - 37
PVC (rigid)	No	Acceptable	0,2 - 0,6	Yes	Transparent	1,25 - 1,43	Marginal	41,4 - 52,7
PET (unfilled, amorphous)	No	Acceptable	0,3 - 0,5	Yes	Optical quality	1,64 - 1,67	Excellent	50 - 55
PLA	Yes	Acceptable	0,3 - 0,4	Yes	Transparent	2,34 - 3,20	Good	55 - 72
PS ('crystal')	No	Excellent	0,4 - 0,7	Yes	Optical quality	1,91 - 1,95	Excellent	28,7 - 41,4
PC (Low viscosity)	No	Acceptable	0,5 - 0,7	Yes	Optical quality	3,04 - 3,26	Good	59,1 - 65,2
PC (High viscosity)	No	Excellent	0,5 - 0,7	Yes	Optical quality	3,04 - 3,26	Good	59,1 - 65,2
SAN	No	Excellent	0,3 - 0,5	Yes	Transparent	2,52 - 2,69	Good	68,4 - 82,1

10.4 METALS

Criteria

As described earlier, the material for the pusher has to be a metal because of the forces exerted during the using of the applicator. These forces are exerted when hammering the spinal cage into the intervertebral disc space. As for the plastics, the metal needs to be suited and approved for medical applications, but also cheap since the pusher is also disposable. The material should also survive at least one cycle of gamma radiation sterilization. The pusher will be manufactured by machining, which asks for a high machining speed to speed up the production process.

Conclusion

All of the compared materials have a medical grade and have an excellent resistance for gamma radiation sterilization. The material which was found best suited for the large batch size, is the 410 grade. The material was chosen because it has the highest machining speed, which abolishes its relatively high material price. The stainless steel 410 has the perfect balance between the 5 factors.

Available metals

A selection of possible stainless steel grades is made using the Cambridge Engineering Selector 2017 (CES), together with the previously determined criteria. Below we find the 5 aspects in the selection of the metal (figure 10.3), which are then processed in a table (figure 10.4).

figure 10.3: Metals material criteria



figure 10.4: Metal materials

Material	Medical grade	Machining speed (m/min)	Price (€/kg)	Sterilizability	Yield strength (Mpa)
Stainless steel 316	Yes	20,7	2,82 - 3,30	Excellent	205 - 310
Stainless steel 410	Yes	30,5	1,07 - 1,34	Excellent	276 - 310
Stainless steel 440A	Yes	21	0,886 - 1,06	Excellent	370 - 460
Stainless steel 440A, tempered	Yes	7,92	0,886 - 1,06	Excellent	1490 - 1820
Stainless steel 440B	Yes	20,1	0,886 - 1,06	Excellent	380 - 470
Stainless steel 440 B, Tempered	Yes	7,01	0,886 - 1,06	Excellent	1670 - 2050

11. PACKAGING

11.1 INTRO

The packaging of a disposable instrument should be easy to open, protect the instrument during transport, be able to survive the gamma radiation sterilisation, and ensure the sterility of the product.

11.2 TYVEK

The material which will be used to seal off the spinal cage applicator is a spun HDPE fiber sheet called Tyvek. Tyvek packaging creates less lint and other dust particles, which are unwanted near the surgical site during opening than regular medical grade paper used to seal similar packages (“Sterilization Pouches | DuPont™ Tyvek® | DuPont USA”, 2017). This material can be used to seal off a peel pouch (figure 11.1), or as a lidstock of a thermoformed tray. For this project it is chosen to use a peel pouch, since these take less space when stored, and are a little bit cheaper than thermoformed trays.



11.3 DIVISION

The cartridge with the spinal cage inserted will be packaged separately in another peel pouch. The separation of the cartridge and the spinal cage from the applicator and pusher is done to prevent waste. Since all the instruments in an opened package require to be used or disposed of, they may not be used for a next surgery. Packaging the cartridge separately ensures that the surgeon only uses the required amount of instruments, and not create unnecessary waste.

11.4 PROCESSING

When the instrument is manufactured, it is put inside the peel pouch, which is then sealed off. The packages are put inside cardboard boxes. These boxes are then put through the gamma radiation sterilization process. The boxes are transported to the hospitals and stored until the instruments are required (figure 11.2). The peel pouches are tough and are able to protect the instruments from damage and contamination. When the instrument is needed, the package is opened by an assistant because the outside of the packaging is not sterile. The surgeon or scrub nurse then removes the instrument from the peel pouch (“Sterile Packaging | DuPont™ Tyvek®— Medical and Pharmaceutical | DuPont USA”, 2017).

figure 11.1: Tyvek peel pouch

(DuPont, n.d.)

figure 11.2: Packaging and transport order

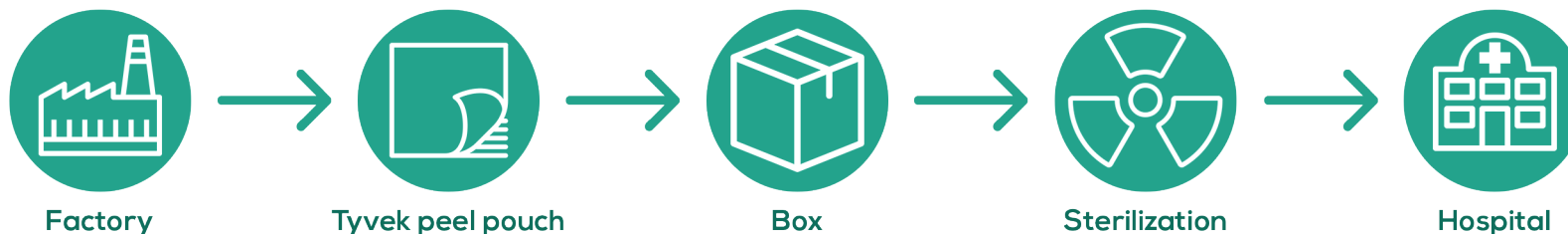
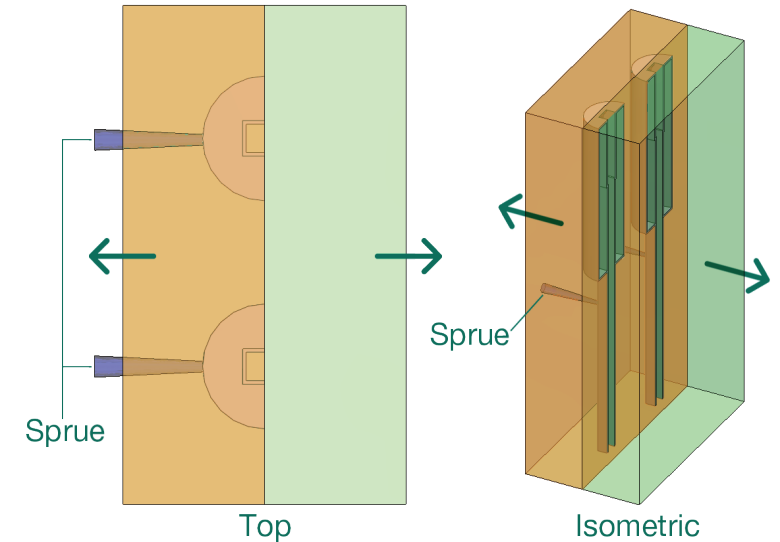

figure 12.1: Applicator injection mold design

12. PRODUCTION PROCESS

12.1 INTRO

This part will present the chosen production process of each part of the applicator. With the batch size known at 10.000 spinal cages and 5000 applicators annually, it is possible to choose a manufacturing process which suits this number. For the plastics, it is decided to use the process of injection molding. The assembly methods for the applicator and the injection mold design will be shown here, as well as the manufacturing process of the pusher.



12.2 APPLICATOR AND CARTRIDGE

The applicator will be made in two parts (figure 12.1) which will be joined together. The method of joining is required to be suited for the PC material, and the gamma radiation sterilisation process. The joining method which will be used is solvent bonding. Solvent bonding is chosen above other adhesives since this bonding technique is cheap, creates a bond which is as strong as the parent material, and is already widely used with polycarbonates (CES Edupack 2017, 2017). Extra care should be taken in choosing the right solvent agent and in the bonding procedure as stress cracking is a common problem with polycarbonates (“How to prevent stress cracking - Permabond”, n.d.). Commonly used solvents are methylene chloride and ethylene dichloride.

The applicator is molded in a two cavity mold because the halves have small differences in geometry. These geometries help the two halves align properly when they are bonded together. The cartridge is molded as a single part (figure 12.2).

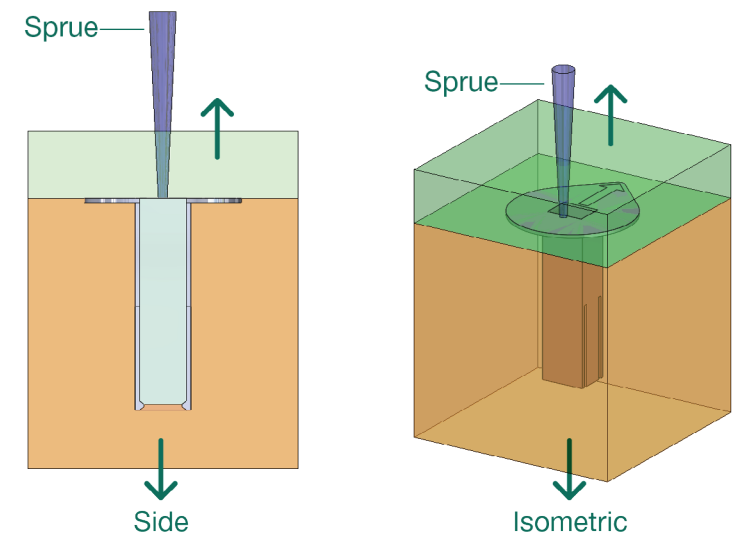

12.3 PUSHER

An expert from the IDE workshop, and B. Overtoom from the DEMO workshop at 3ME, and S. Leeflang, all from the TU Delft, with knowledge of metal processing, and 3D metal printing, were consulted to gain knowledge about the possibilities for manufacturing of the pusher and spinal cage connection. These experts opted for a two part construction, a knob and a rod. They advised to join these two parts using a bonded thread (figure 12.3). This involves joining the two parts with a thread and an industrial grade adhesive to lock the two parts in place and avoid to parts coming loose.

Rod

The rod will be manufactured from a single hexagonal rod (figure 12.4). Only the connection with the knob and spinal cage will be machined. The rod will not have a grip pattern machined into its surface because this would be too expensive. The hexagonal shape of the rod is chosen to still provide some rotational grip to the user. The connections with the knob and spinal cage are both threads. All these machining actions can be performed using a lathe. A threaded connection with the spinal cage is possible since a threaded hole can be machined into the titanium cage.

Knob

With the large batch size and disposable design of the applicator in mind, it is chosen to make the turning knob from a hexagonal rod as well. Using this manufacturing process, the material for the knob only needs to be cut from the bulk material, and provided with a threaded hole. This produces a part with little machining costs. This process is similar to producing nuts.



figure 12.3: Bonded thread joining

Bolts with pre-applied lockign agent (NDIndustries, n.d.)



figure 12.4: Hexagonal rods

(Made-in-china, 2017)

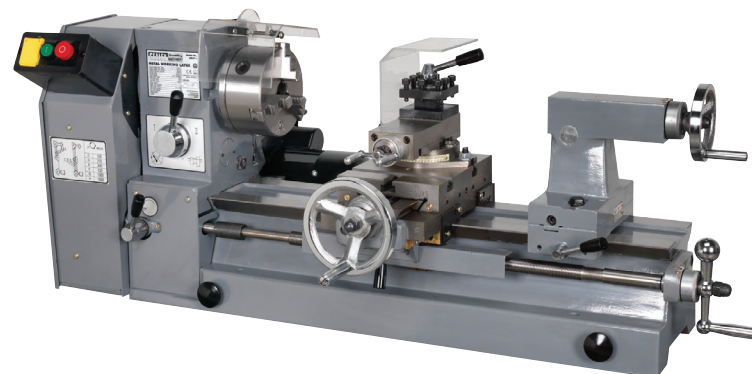
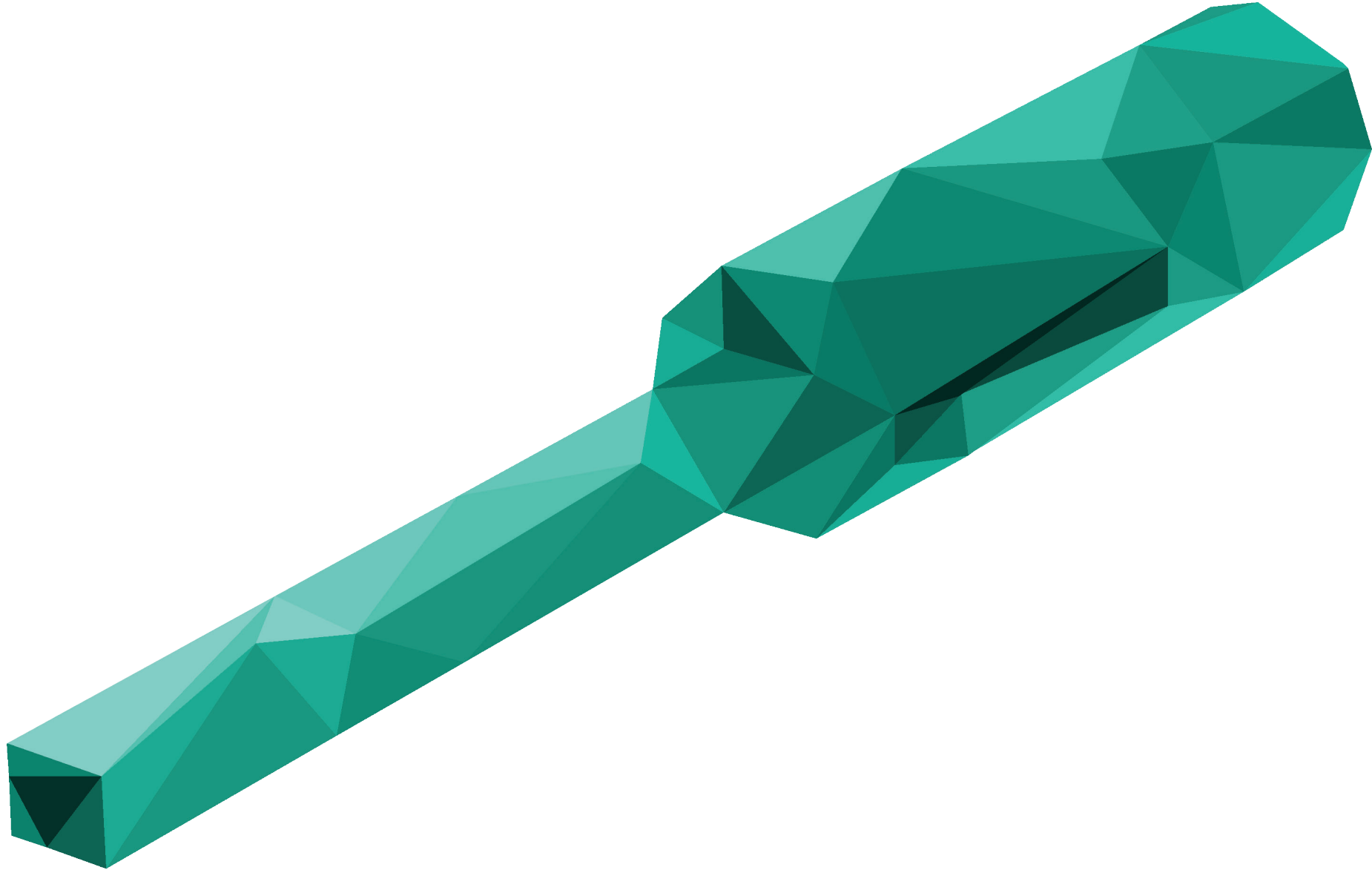

figure 12.5: Lathe

(Ebay, n.d.)

**DESIGN
PROPOSAL**



*figure 13.1: Context image
final design ClearFix*

Image shown on right page.

*figure 13.2: Exploded
view ClearFix*

Image on page 57

*figure 13.3: Use step
details*

Image on page 58

13. FINAL DESIGN

13.1 INTRO

The final design of the spinal cage applicator instrument is called the ClearFix. The ClearFix is created as a solution to the assignment stated at the beginning of this report:

“Design a surgical instrument or set of instruments for the “Minimally invasive multi-segment spinal cage with NiTiNol hinges.” project which facilitates the placement and deployment of the spinal cage at the intended location inside the body”.

The design of the ClearFix is the product of an iterative process, where multiple designs were tested and improved upon in quick succession. This is the fourth and final design created for this graduation project.

13.2 GENERAL DESCRIPTION

The function of the ClearFix is to allow the neurosurgeon to insert a spinal cage into the intervertebral disc space during a minimally invasive PLIF surgery. The ClearFix is designed to be quick and easy to use. This is done by optimizing the workflow and workload of the instrument. The workflow of the entire use cycle is kept simple, with a small amount of steps which are easy to perform. The user’s actions are designed to induce a low workload. User tests confirmed these desired effects. The system is easy and intuitive to use, and induces a low workload on the users.

The ClearFix incorporates a cartridge which houses the spring loaded spinal cage. The cartridge allows the user to quickly and easily prepare the instrument for insertion. It is assumed that the clear polycarbonate parts allows the surgeon to have a good view on the surgical area. This should give the surgeon a greater confidence when inserting the spinal cage, however this would need to be validated in further testing. To insert the spinal cage into the body, a connection is made with a stainless steel pusher to allow for a controlled descent. The connection is made using a thread. The ClearFix is designed to be disposable to remove the need for sterilization. This creates a shorter use cycle and simpler workflow. It also removes the hazard of cross contamination.

13.3 RISK ANALYSIS

A risk analysis is performed to evaluate the height of the risks while using the ClearFix. The FMEA (Tague, 2005) technique is used and the following risks are evaluated:

- Drop:
 - Cartridge
 - Applicator
 - Pusher
- Wrong insertion orientation;
- Failure of spinal cage connection;
- Failure of the applicator;
- Failure of the blocking mechanism;
- Insertion without making contact with spinal cage.

The risk is calculated by multiplying severity (1 - 10) with the chance of occurrence (1 - 10). Using this calculation and a scale which is assumed to be fitting for this particular surgical procedure, it is found that all the risk levels are low. Except for the risk of dropping the cartridge, which is medium (appendix J). Therefore extra care and attention is required while performing this action.



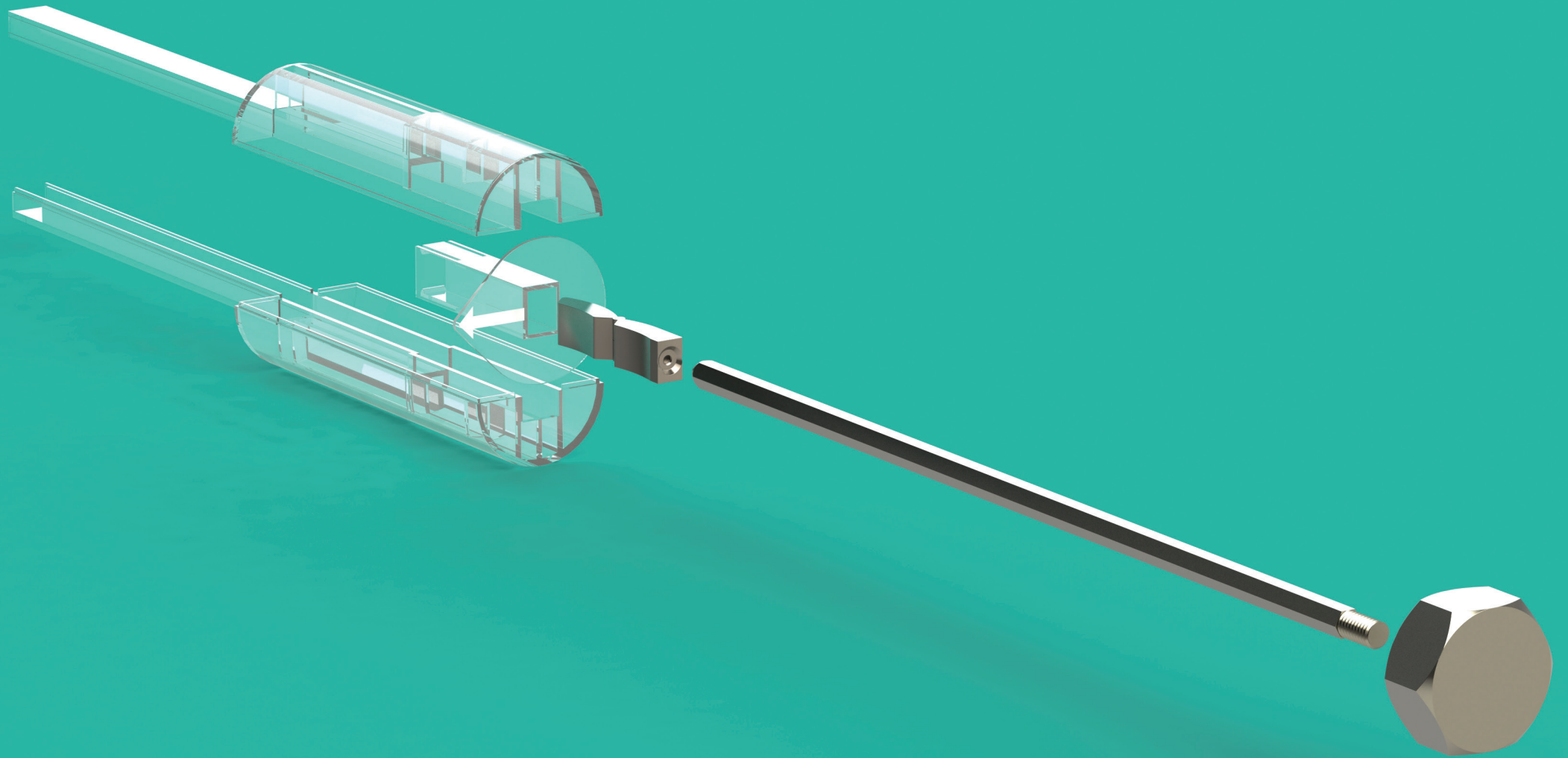

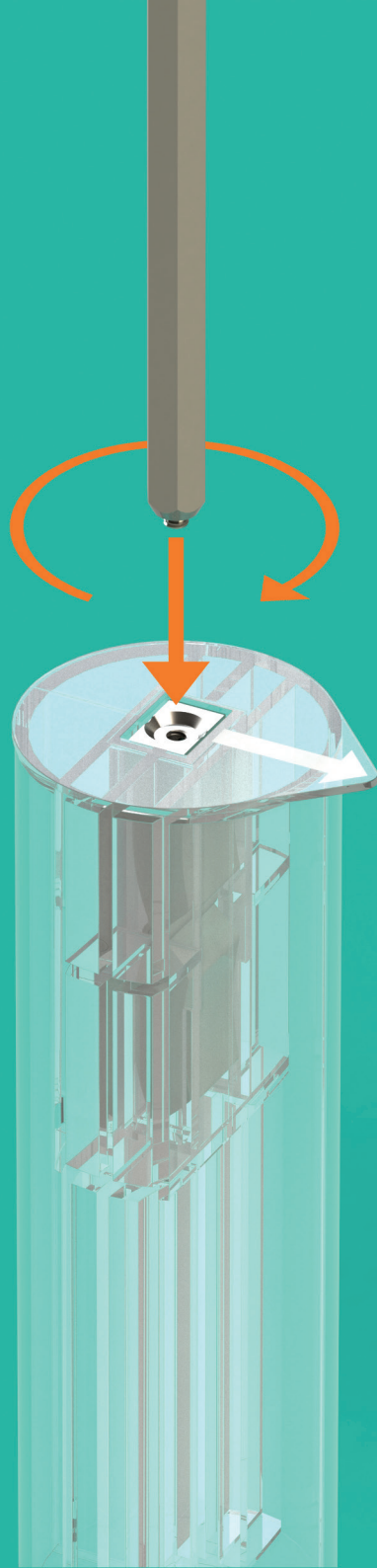
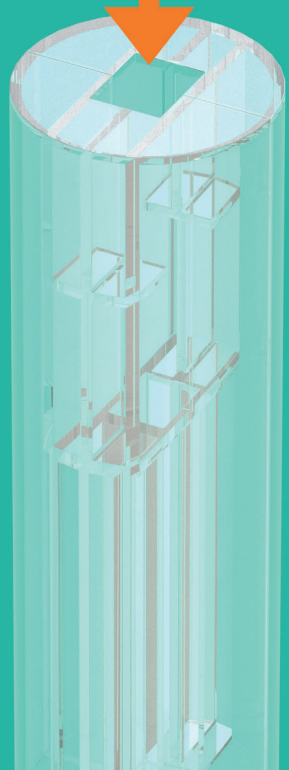
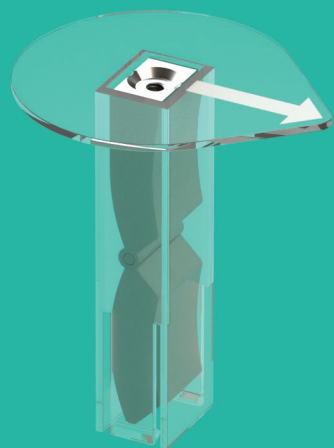

figure 13.4: Overview
applicator

Right image

13.4 PARTS

Applicator

The function of the applicator part is to create a safe channel through which the spinal cage can be advanced while keeping the spring loaded spinal cage in a straight orientation. The part is injection molded from clear polycarbonate (PC). A clear plastic was chosen to allow the surgeon to see partially through the applicator and give the surgeon a better view of the surgical area than when opaque materials are used. This decision was made after the latest test with an opaque applicator revealed that the users still desired a better view on the surgical area. The clear design also allows the surgeon to track the location of the spinal cage when inside the applicator, while inserting the implant. The applicator is rotationally symmetric. This ensures that the cartridge can be inserted without having to pay attention to the relative orientation of the two parts.

figure 13.5: Applicator
halves assembly

Left image

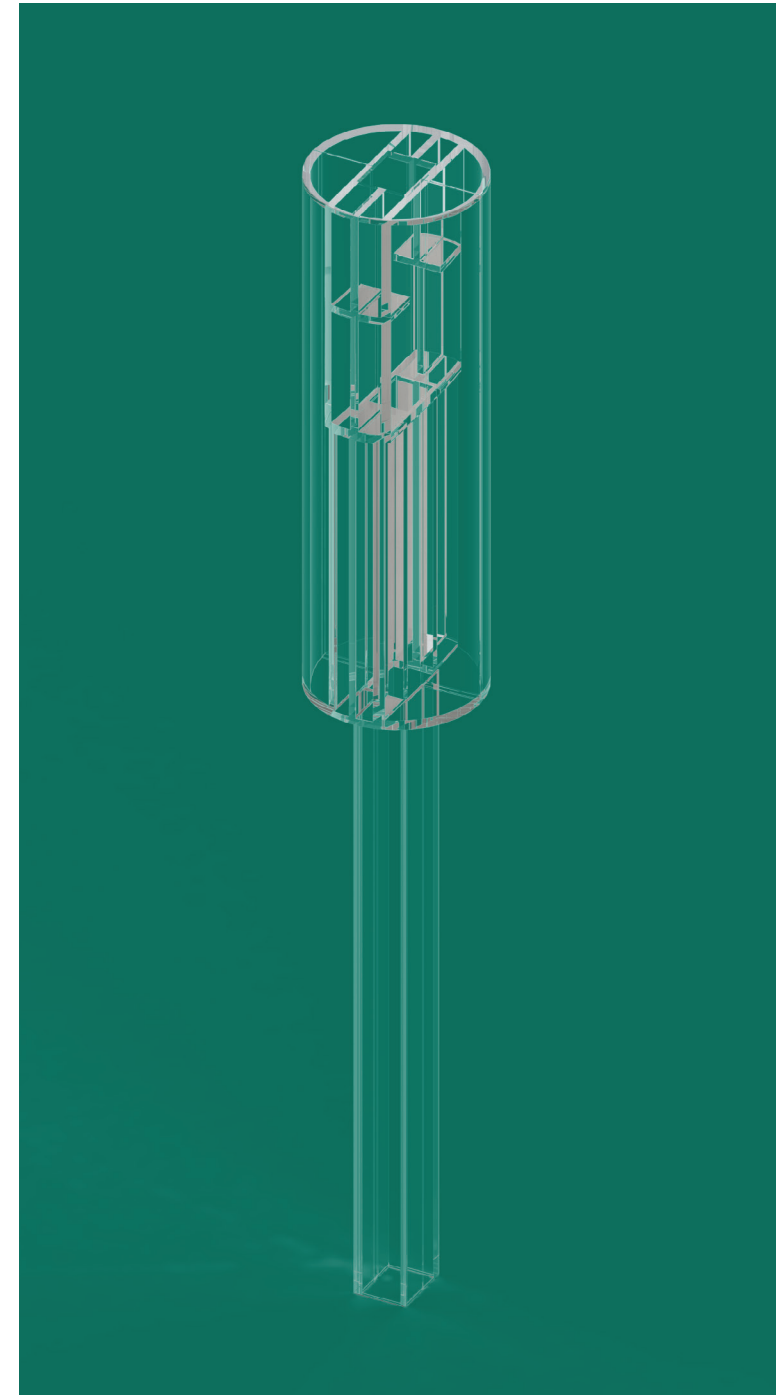
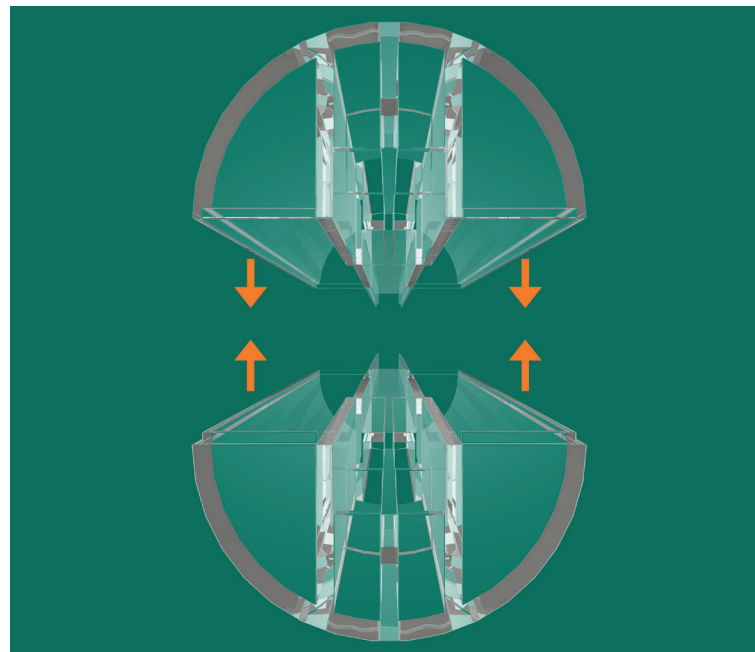

Pusher

The pusher is the part which controls the insertion of the spinal cage. The pusher is connected to the spinal cage with a thread. The design of the connection is altered to reduce the chance of structural failure, even though the connection design was successfully tested in an animal test by M. Ahmadi (figure 13.7). The thread is designed to avoid the application of too much torque when making the connection, and too high impact forces when inserting the spinal cage, which might destroy the thread. To accomplish this, the thread is followed by a cylindrical section with a smaller diameter. This narrow section allows the thread of the pusher and spinal cage to pass each other when making the connection, and allows the pusher to freely rotate when fully connected. The flat surface which follows the narrow section is there to apply the impact force onto the spinal cage, and advance the implant into the intervertebral disc space. The hexagonal profile of the pusher is chosen because it is easy and cheap to manufacture while still providing some rotational grip to the user.

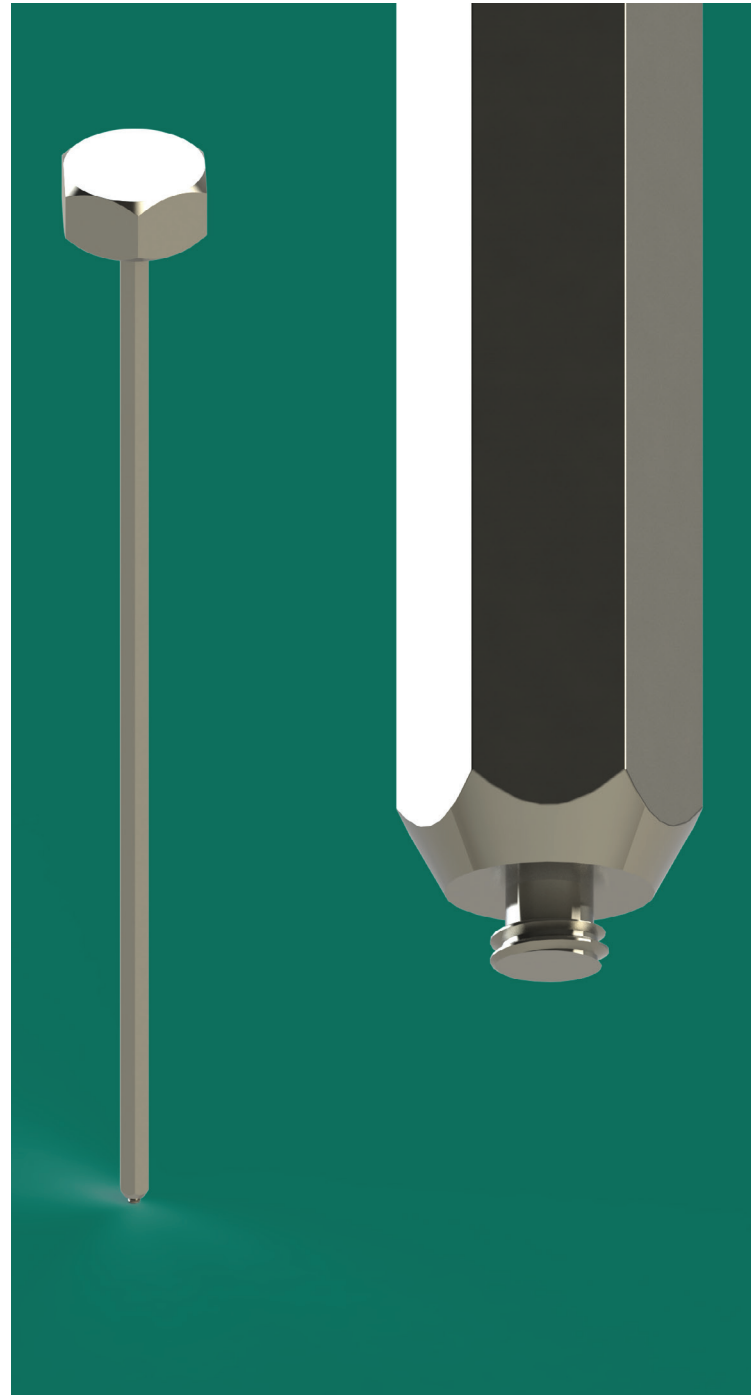

figure 13.6: Pusher overview and connection detail

Right image

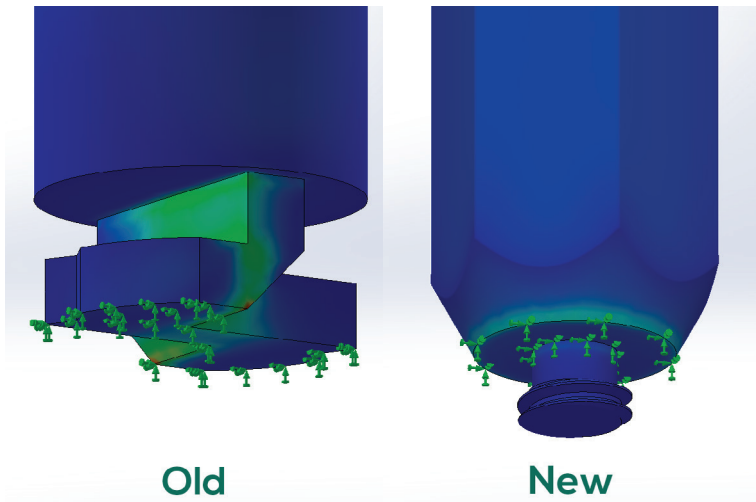

figure 13.7: Connection force comparison

Left image. In both studies, the impact surfaces that connect to the spinal cage were fixed, as seen in the image, and an impact force was applied to the other end of the model. The old model shows higher stresses (green areas) throughout the connection when compared to the new connection geometry.

figure 13.8: Cartridge overview

Right image

Cartridge

The function of the cartridge is to allow for an easy and quick insertion of the spinal cage into the applicator, to prevent the spinal cage from traveling down the applicator without a connection with the pusher, and to help the surgeon to identify the deployment direction of the spinal cage. The easy and quick insertion is achieved by creating a tube which keeps the spinal cage in a straight orientation and can easily inserted into the applicator. This ensures that the user does not have to fiddle with the spring loaded spinal cage to insert it into the applicator. The cartridge prevents the cage from traveling down the applicator by blocking the shaft with two snap fingers. The snap fingers are designed with an angled surface. This allows the snap fingers to part when enough force is applied onto the spinal cage. The spinal cage is designed with a spring loaded hinging mechanism. The hinging direction is called the deployment direction. When the spinal cage is loaded into the applicator it can be difficult to see which direction the cage will hinge when it enters the body. To help the surgeon identify this direction, an arrow and a pointed shape are added to the design of the cartridge. The arrow is made with a bumpy pattern to create an opaque area.

figure 13.9: Snap fingers detail

Left image

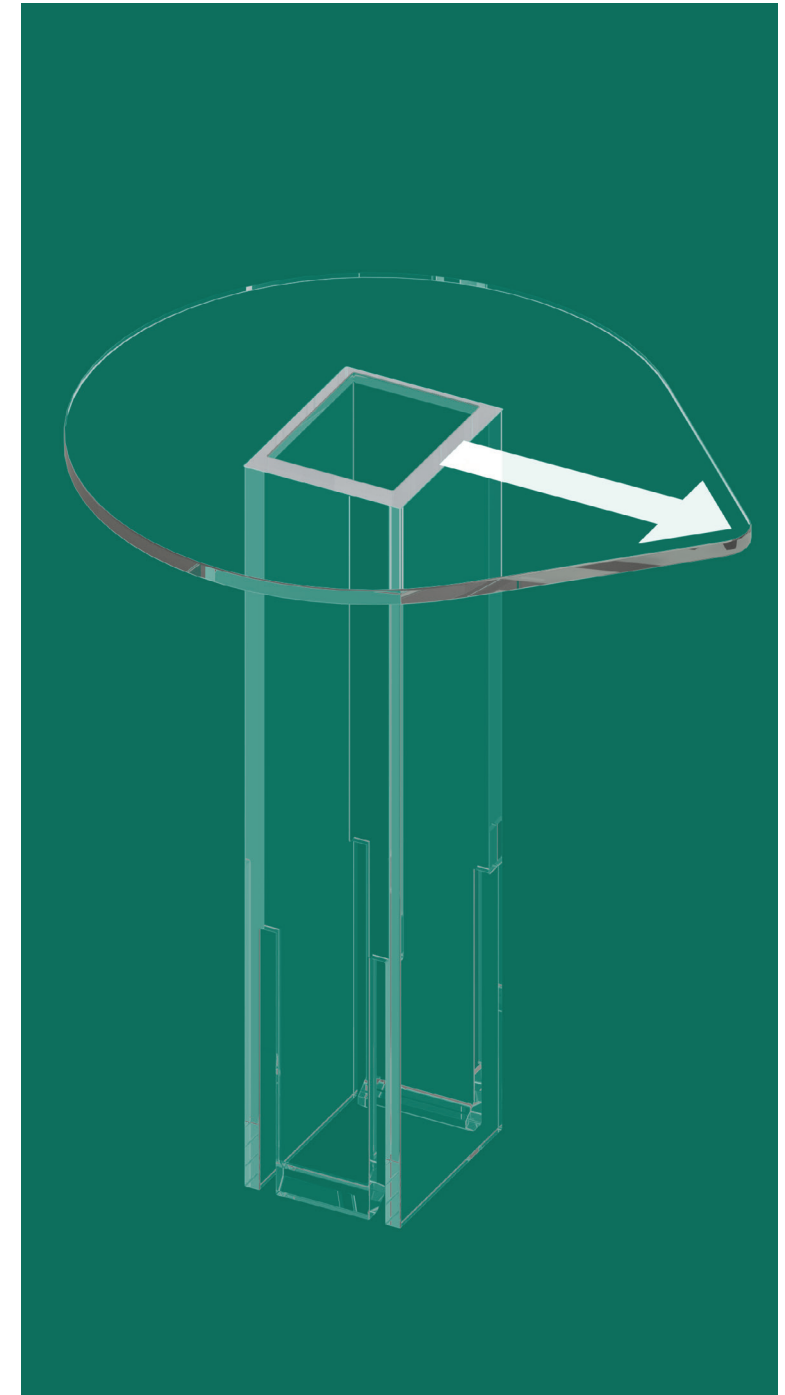

Spinal cage connection

The spinal cage is designed by M. Ahmadi. During this graduation project, it was only possible to design the connection between the spinal cage and the pusher. The connection consists of a short thread, followed by a larger diameter opening where the thread of the pusher can freely rotate as explained before. Around the perimeter of the threaded hole, there is a flat surface to receive the forces of being hammered into the intervertebral disc space. A tapered surface is added to help guide the pusher to the right location to make the connection. An extra hole is printed into the side of the spinal cage, to allow for easy removal of the metal powder after the implant is 3D printed.

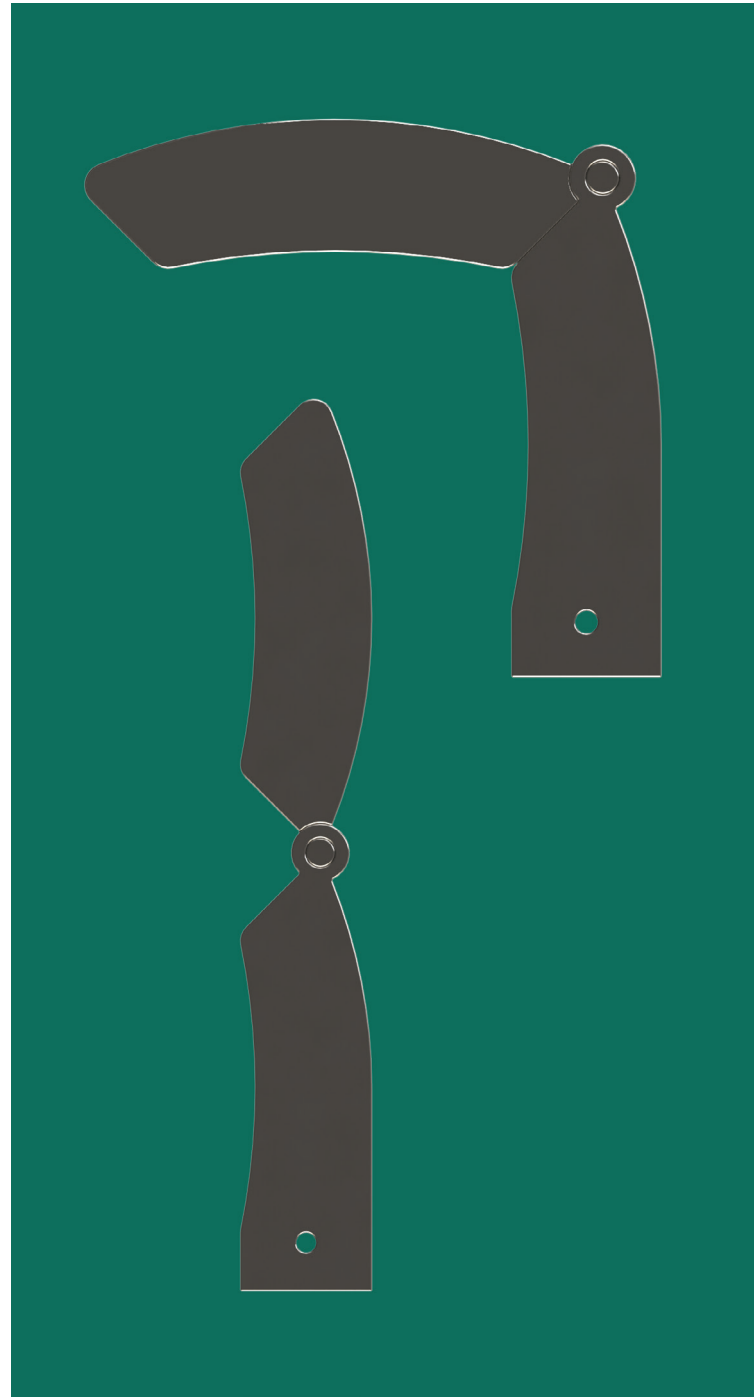
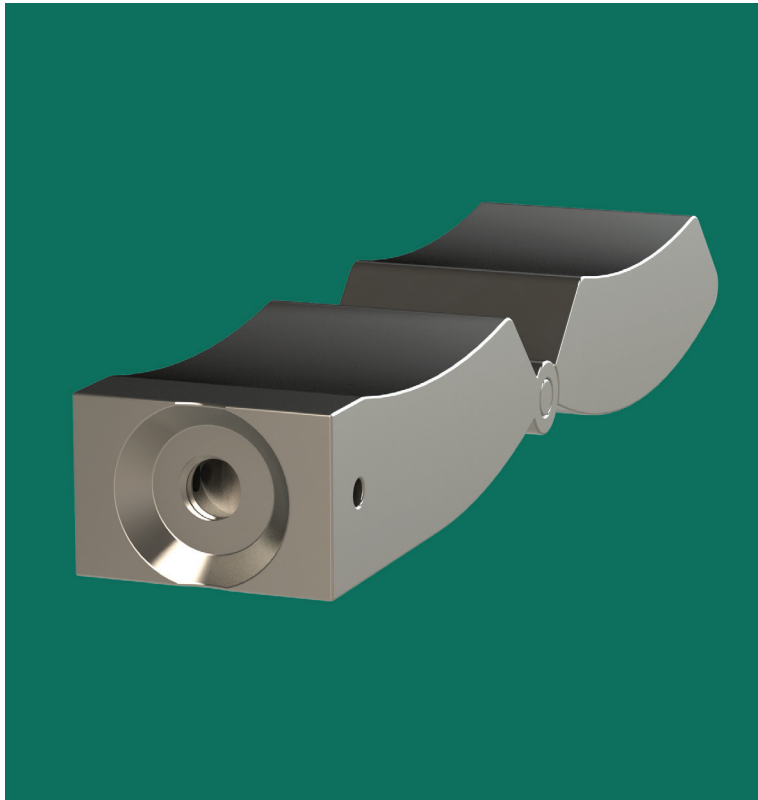

figure 13.10: Top view of hinged and straight spinal cage

Right image

figure 13.11: Spinal cage connection detail

Left image

13.5 COSTS

According to the producer of the spinal cage, M. Ahmadi, the ClearFix will be provided for free, together with two spinal cages. The price paid by the hospitals is only determined by the implant. The production costs of a set of spinal cages is approximately € 800,-. The selling price of a set of spinal cages will be € 1200,- to € 1500,-. To keep the profits from the spinal cages as high as possible, the disposable ClearFix should be manufactured as cheap as possible. The manufacturing costs of ClearFix are shown in figure 13.12 and result in a total manufacturing cost of € 5,49.

While calculating these costs, assumptions are made about the machining costs, hourly wage, and manufacturing time of the individual parts. The parts are planned to be made in China to keep the manufacturing costs down. More elaborate manufacturing cost calculations on all the separate parts can be found in appendix G. Shipping costs are excluded from this calculation.

figure 13.12: Part costs table

Part	Manufacturing costs	Notes
Applicator	€ 2,85	2 x injection mold part (€ 1,423)
Pusher	€ 1,53	Knob (€ 0,58) + Rod (€ 0,95)
Cartridge	€ 1,08	2 in one set (€ 0,54)
Peel pouch	€ 0,03	3 x pouch (€ 0,01)
Total	€ 5,49	

13.6 DIMENSIONS

Applicator

The dimensions of the applicator part are determined by the manufacturing process and the use context. The length of the tube which is inserted into the body, is determined by the longest commonly used tubular retractor (METRx system Surgical technique, 2009) available (9 cm) and the extra length required to reach the intervertebral disc opening (+/- 3 cm), plus an extra 1 cm length for added variability between anatomy (figure 13.13). The handle size is determined by dimensions explained by van Veelen, Jakimowicz & Kazemier, 2004. The wall thickness is chosen to be 1.5 mm. The cross section dimensions of the tube is determined by the size of the spinal cage. Complete dimensional drawings are found in appendix I.

The two halves of the applicator are slightly different. One has a small extrusion at the edge of 0.75 mm wide and 1 mm tall (figure 13.14), and the other half has a cut extrusion in that same position in which it can receive the extrusion. This helps to properly align the two parts while they are being bonded together.

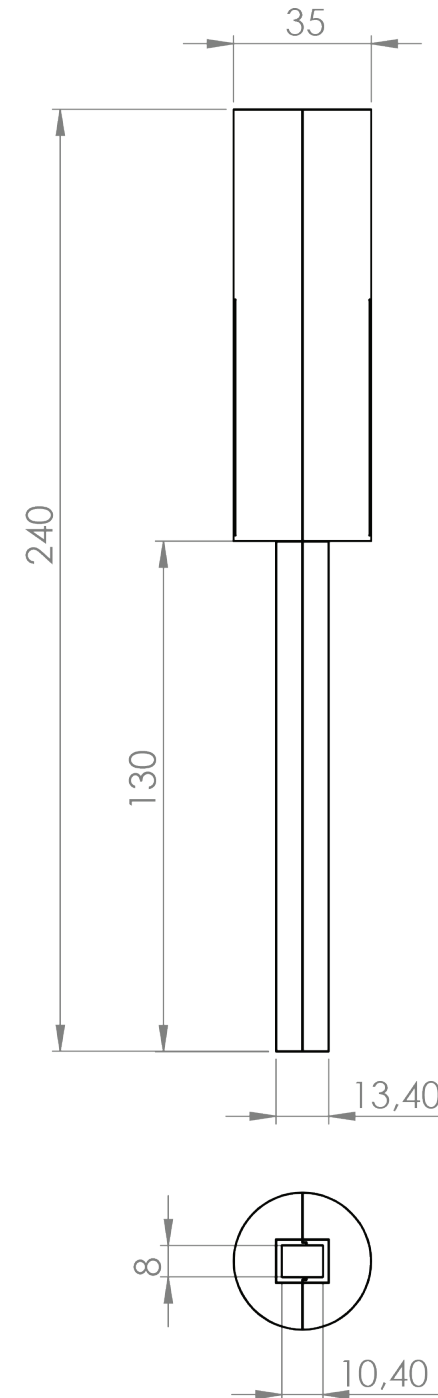
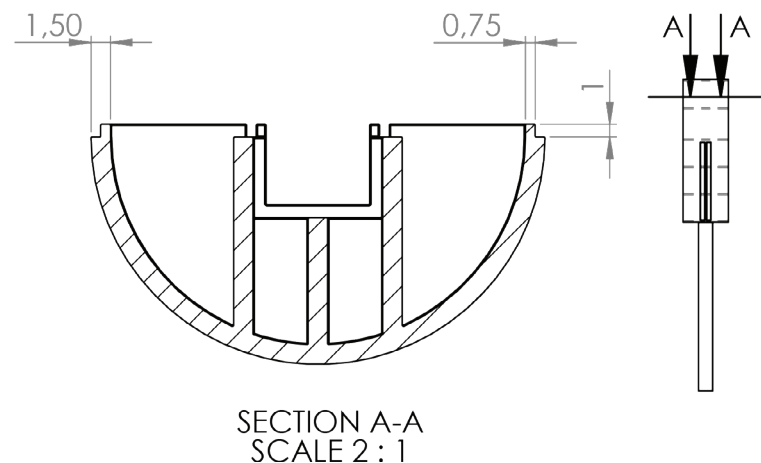

figure 13.13: General dimensions applicator

Right image, dimensions in mm.

figure 13.14: Injection mold comparison

Left image, dimensions in mm.

figure 13.15: Pusher
general dimensions

Right image, dimensions in mm.

figure 13.16: Spinal cage
general dimensions

Left image, dimensions in mm.

Pusher and spinal cage

The length of the pusher is derived from the length of the plastic applicator part and the connection of the spinal cage. This way the spinal cage will be pushed exactly past the end of the applicator. The dimensions of the thread are chosen to leave at least 2 mm of material on each side of the thread hole in the spinal cage. This way it is assumed that the structural integrity of the spinal cage is not compromised when under load when inside the body. The diameter of the rotation knob is chosen to be flush with the outer perimeter of the handle of the applicator. The height of the rotation knob is determined to be 15 mm (Karwowski, 2006).

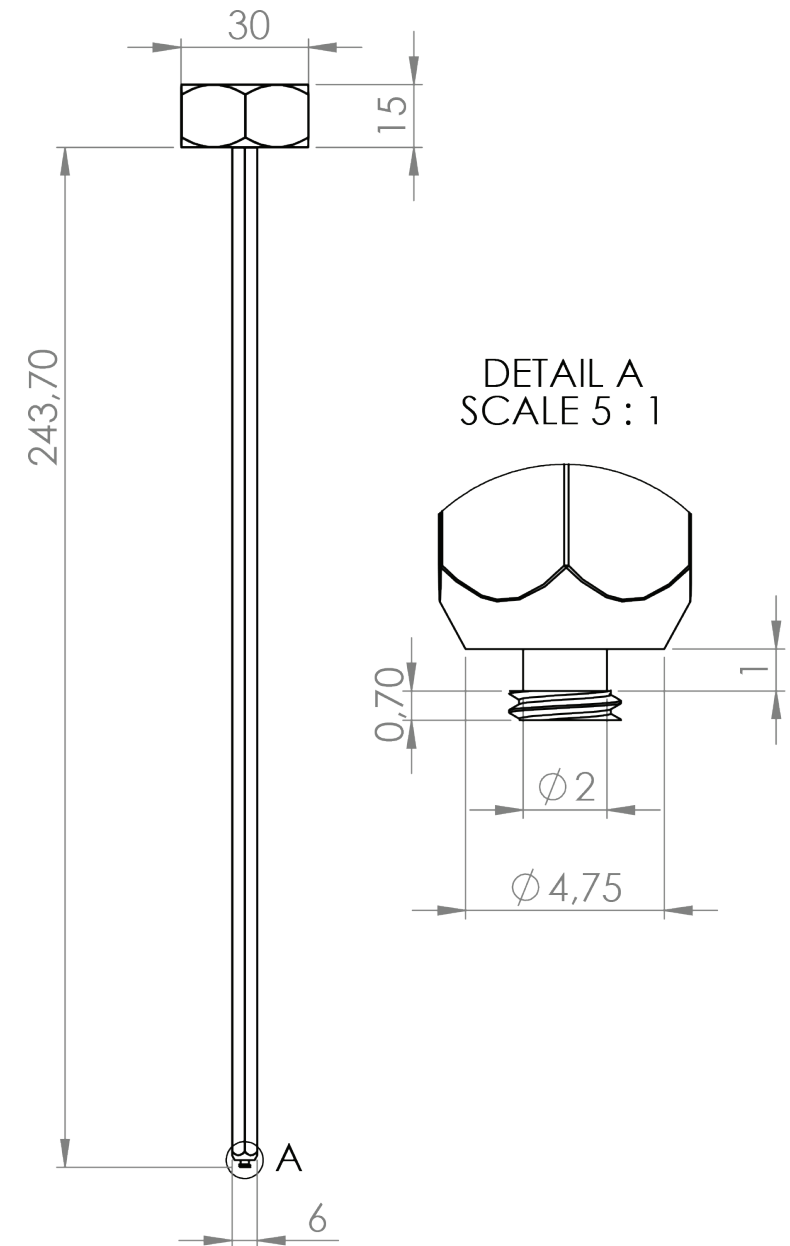
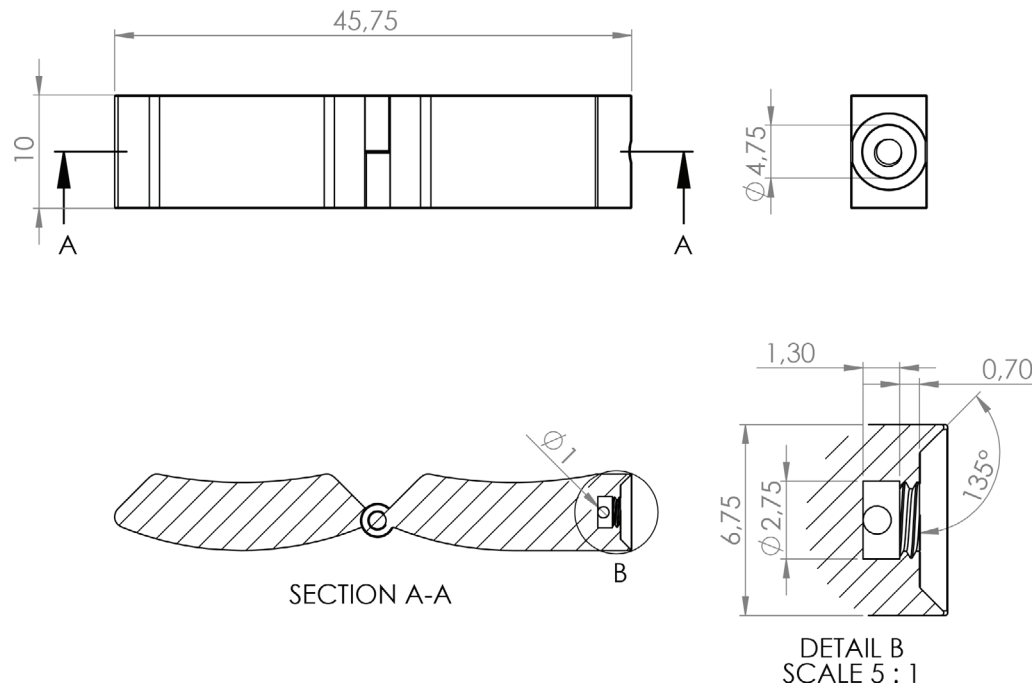

Cartridge

The length of the applicator is determined by the length of the straightened spinal cage, plus the blocking dimensions of the snap pingers (48mm total). The cross section of the rectangular tube has the same inner dimensions as the shaft in the applicator part to allow for a smooth transition of the spinal cage between leaving the cartridge and continuing down the shaft. The length of the snap fingers are calculated to have a deflection force of 2N each (figure 13.18). It is assumed that this deflection force is enough to keep the spinal cage from sliding down the applicator and providing enough resistance to make the connection between pusher and cage. All while still being easy to push the cage out of the cartridge when inserting the spinal cage into the intervertebral disc space.

Used formulas are:

$$d = (F \cdot L^3) / (3 \cdot E \cdot I), \text{ and } I = (X \cdot Y^3) / 12$$

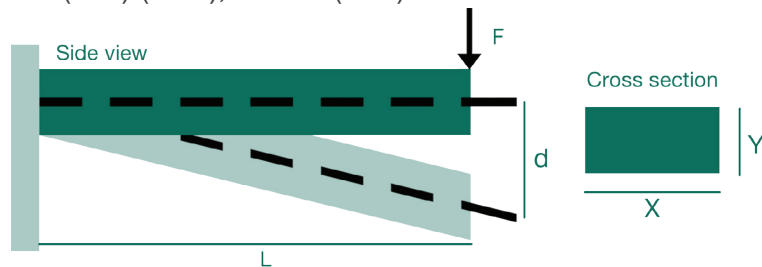

```

> restart;
> F := 2 : d := 1 : E := 2380 : X := 6 : Y := 1 :
> I =  $\frac{X \cdot Y^3}{12}$  :
> L = evalf  $\left( \left( \frac{d \cdot \left( 3 \cdot E \cdot \left( \frac{X \cdot Y^3}{12} \right) \right)}{F} \right)^{\frac{1}{3}} \right)$ 

```

$L = 15.28349709$

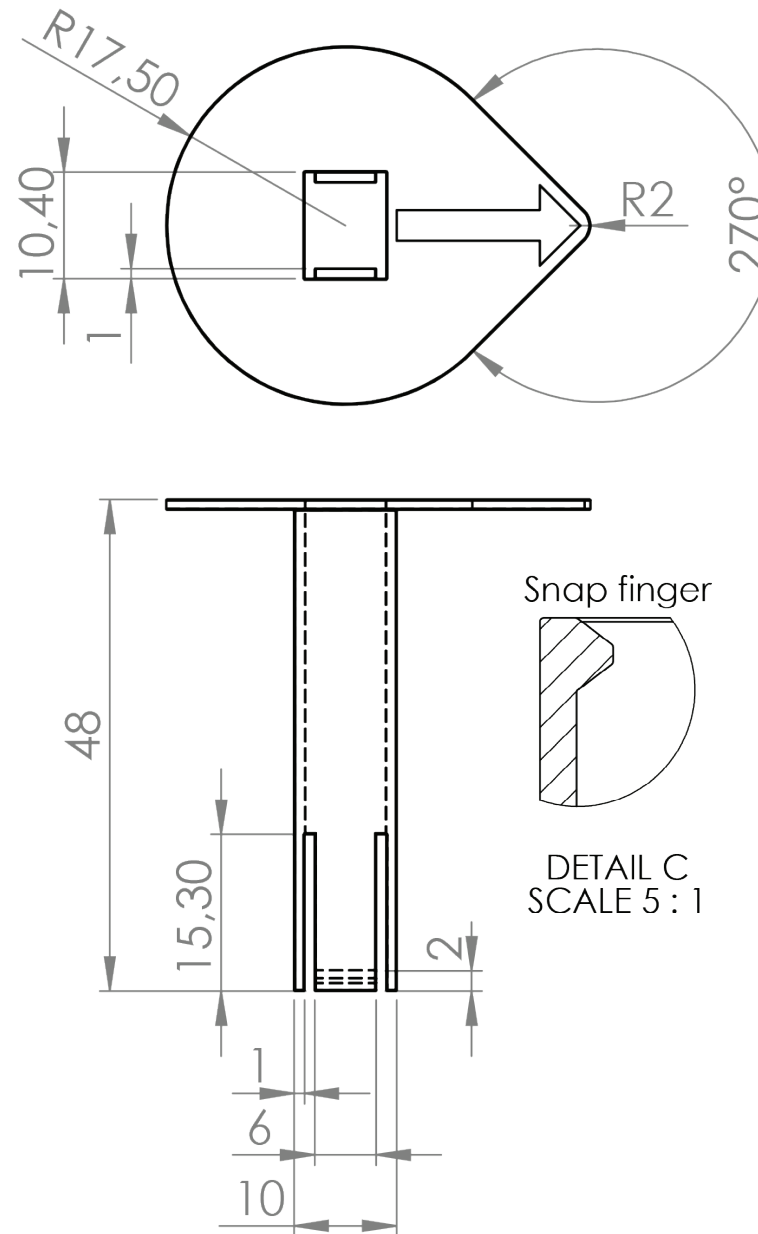

figure 13.17: Cartridge general dimensions

Right image, dimensions in mm.

figure 13.18: Snap fingers calculation

Right image

14. WORKFLOW

14.1 INTRO

The new spinal cage applicator design requires a new workflow. The workflow of an existing system was analysed in part 4 of this report. To improve on this workflow, the applicator is made disposable and reduces the time required to prepare the instrument during surgery. The new workflow is based on user observations and feedback collected from the use tests performed with the previous designs.

14.2 WORKFLOW

The workflow which was observed and analysed in part 4 consisted of three use phases, preparation done by the scrub nurse, spinal cage insertion by the surgeon, and sterilization by the CSSD employee. In this workflow it became clear that the most improvements could be made by eliminating the need for sterilization, and by reducing the preparation time and workload for the scrub nurse.

The new workflow improves on these areas by doing exactly that. There is no need for sterilization since the instrument is designed to be disposable. And the preparation is made easier and faster by implementing a cartridge which is easy to insert into the applicator.

The new workflow is presented in figure 14.1. The first step is to remove the instrument, and the cartridges with the spinal cages from the peel pouches and put them on the surgical instruments table. This is performed by a surgical assistant, not the scrub nurse or the surgeon. This is because the outside of the peel pouches is not sterile and may not be touched by the surgeon and scrub nurse.

Next, the surgeon will place the applicator on the recently created opening in the intervertebral disc space. This creates a safe channel through which the spinal cage can be inserted without damaging any delicate anatomical structures like the nerve roots.

When the applicator is positioned as the surgeon sees fit, the cartridge containing the spinal cage is inserted into the applicator. The scrub nurse then hands the pusher to the surgeon who connects the pusher to the spinal cage.

The surgeon then proceeds to push the spinal cage down the shaft of the applicator. Then the cage enters the intervertebral disc space, the surgeon will use a mallet to hammer the spinal cage into place.

When the cage is inserted, the pusher is unscrewed from the spinal cage. The applicator and pusher are then removed from the patient's body. The second spinal cage is then inserted following the same steps.

Finally, a run is performed to confirm the correct positioning of the spinal cage. After the surgery, the applicator, pusher and cartridges are disposed of with the other disposable instruments.

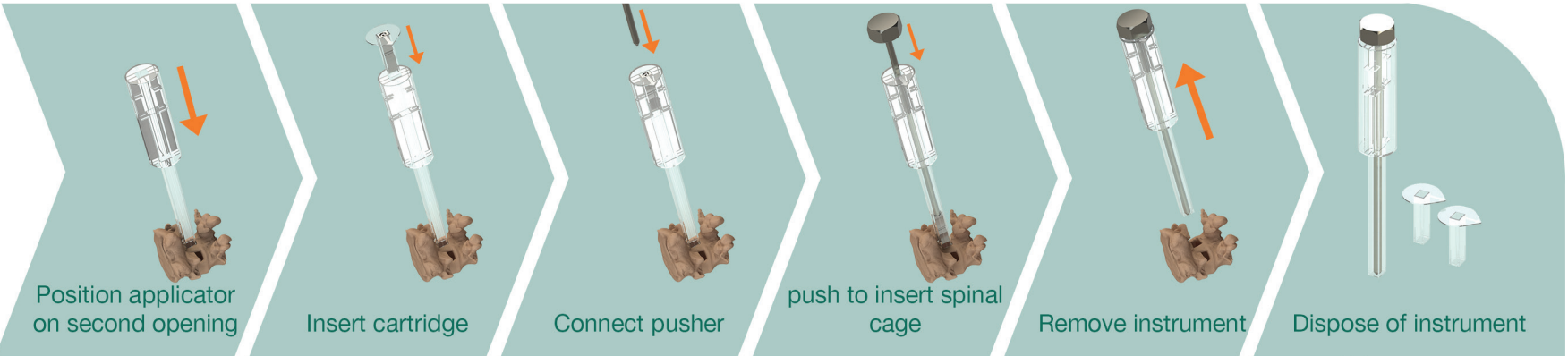
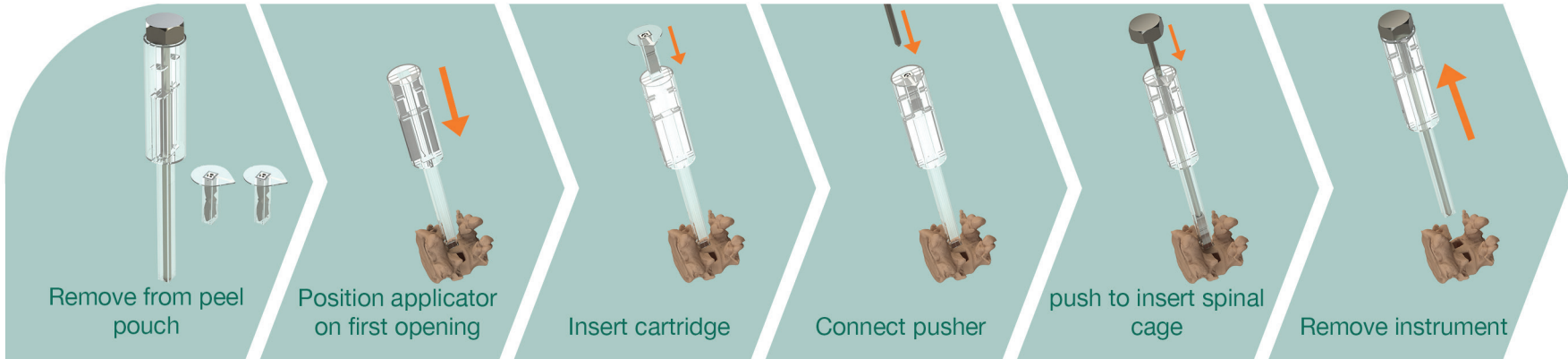

Assistant

Surgeon

Assistant



15. EVALUATION

15.1 REFLECTION

Design process

Design Brief:

The graduation project is originated as part of a larger project proposal by M. Ahmadi, named:

“Design new applicators and surgical instruments for the minimally invasive surgery”.

One of the aims of this project is to *“Design new applicators and surgical instruments for the minimally invasive surgery”.* This is where the graduation project kicked off. The design brief, which was formulated shortly after, was:

“Design a surgical instrument or set of instruments for the “Minimally invasive multi-segment spinal cage with NiTiNol hinges” project which facilitates the placement and deployment of the spinal cage at the intended location inside the body”.

Research phase:

During this first phase of the project, information was gathered about the context in which the new applicator was going to be used. During this phase, it was quickly determined that a neurosurgeon was needed to provide feedback on the designs and information about the context of the surgical procedure. The neurosurgeon who was willing to help with this project phase was Dr. G. de Ruiten from the Medisch Centrum Haaglanden. Since neurosurgeons run by a tight and irregular schedule, it was hard to find the right time for the surgeon to help out with tests and observations for the project, which is one of the reasons the project took a bit longer.

Early on in the research phase, it was decided that a workflow analysis would provide an interesting starting point, from which a spinal cage applicator could be made. The workflow analysis was the largest part of the overall analysis, and was even worked on during the synthesis phase. As part of this workflow analysis, two observations were made in a PLIF surgery, one trip was made to the CSSD of the Erasmus MC, and interviews were performed with a neurosurgeon, scrub nurse, and a CSSD employee. The main areas of improvement over an existing applicator system were found thanks to these observations and interviews.

Ideation phase:

During the ideation phase it became clear that the predetermined function and context of the spinal cage applicator made little room for deviation. It was found that the conventional design process used at the faculty of IDE did not suit this particular assignment. Therefore it was chosen to use the lean startup method, which has a shorter design cycle and incorporates a more iterative process. This resulted in a short ideation phase as the lean startup process promotes making a first design on short notice. The first design was far from being an ideal product and contained a lot of areas which needed improving.

Synthesis phase:

The design of the spinal cage changed a lot during the early stages of the synthesis phase, the phase where the different iterations were built, tested and improved upon. These changes caused some delays, since the designs of the applicator need to be altered to fit the updated spinal cage design. In order to be able to continue this project, there was decided to work with the design of the spinal cage at a certain point. Any further designing changes would not be taken in account for the designing of the applicator.

The second design incorporated the spinal cage, which would be used throughout the rest of the project. For the second design it was difficult to find creative solutions for the connection between the pusher and the spinal cage, and to stop the spinal cage from falling down the shaft while still allowing for a controlled descent. These two problems proved to be the ones which needed the most attention, and therefore the most time to solve properly. Testing this second design proved that the formed idea was deemed easy and intuitive according to the testing participants. The way the solutions were implemented still needed improving.

Between the second and third design, another test was performed to determine the orientation sign on the instrument, this sign was needed to ensure a correct insertion of the spinal cage. There were also tests run to ensure the most comfortable grip suited for a precision grip, and which geometry of the connection between pusher and spinal cage was preferred by the test subjects. These test all had a successful outcome, which led to the third design.

The previously mentioned delay due to the schedule of the neurosurgeons, was especially in the period of the third design a great factor. For the testing of the third design, medical professionals were required for their expertise. Sequential, the paper which was planned to write based on this project, had to be dropped due to a lack of information for improving the final design. The main problem which was found during the evaluation of the third design, was the blocking mechanism which was used to stop the spinal cage from falling down the shaft. The tear trough design might cause plastic particles to end up inside the body of the patient, and was therefore deemed unsuited for this application. An alternate solution was created during the following phase.

During the testing with the third design, an animal test was conducted by M. Ahmadi, where he tested his spinal cage design. This test used an insertion tool which was heavily inspired by the pusher of the second and third design. The instrument used in this test was made from steel. The surgeon expressed he had a positive experience using the instrument. This positive feedback proved that the design has potential, and supports that the design is suited for inserting a spinal cage.

Detailing phase:

The detailing phase was short but did not come without it's own troubles. During this phase, it became clear that the design of the connection between the spinal cage and the pusher was not suited for the forces applied to the connection in its intended use. This problem asked for a redesign. A lot of contact with experts of different manufacturing processes provided the necessary information to make decisions and assumptions about the best suited materials and manufacturing processes.

figure 15.1: The ClearFix while inserting a spinal cage between two vertebrae

Final design

According to feedback from the latest test, the outcome of the design of the ClearFix is working well, and satisfies the design brief which was stated at the start of the project, even when being used in a simulated setup. A surgeon stated that he would use the ClearFix if the spinal cage is proven to work as well. He stated that the instrument is easy and intuitive to use, and requires little training. The ClearFix surgeon liked the safe channel, which is created by the applicator, through which the spinal cage is to be inserted.

The neurosurgeon stated that the system is reminiscent to a system which was used 20 years ago. The instrument also resembles a disposable system with a shaft, and a rod used to push the spinal cage into position, called Luna 360, from Benvenue Medical. These similarities with proven systems are promising for a successful implementation, since these instruments have already been used successfully in a real surgery already.

The ClearFix received a lot of positive feedback during the user tests, but more testing needs to be done to be able to validate the last changes made for the final design. The design requires to be tested in a more realistic test setup, using an actual human anatomy as the target. An example for a test setup would be the use of cadavers.

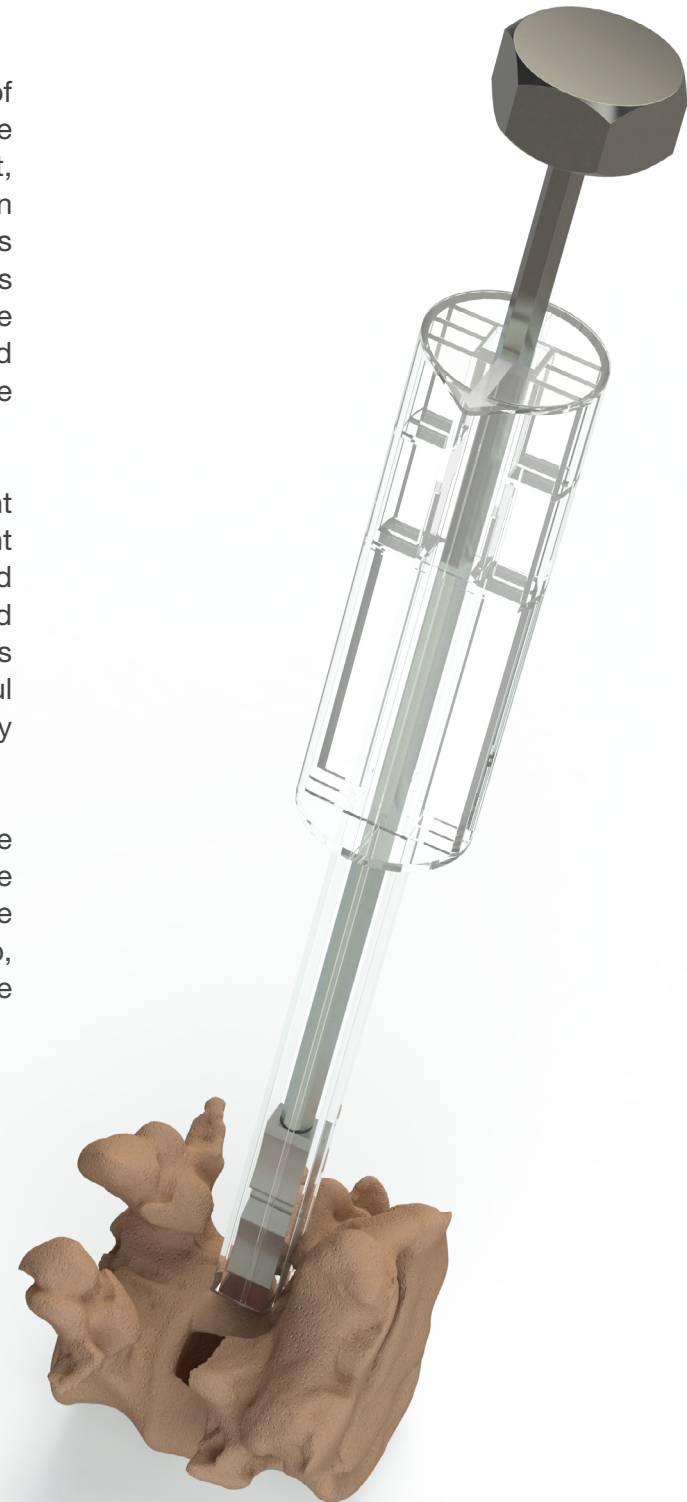

Personal reflection

Short time before this project started, I became a father for the first time. I was aware that having to take care of a young child would demand a part of the energy and time I would otherwise have spend on the graduation project. With this in mind, I chose to work on the project for four days a week instead of the usual five, in order to spend time with my child and be able to give the project the attention it asked for. Nevertheless, my energy levels and productivity would still be tested over the course of the project, due to the lack of sleep every young parent will recognise.

The start of the project went great: the information gathered during the research phases provided me with a good base on which I could start creating several designs. Looking back, I would have made observations of the sterilization and surgery departments earlier in the project, since they provided me with great information. Knowing all this information earlier might have sped up the working process.

In the next phase, the ideation phase, I had some difficulties in finding the perfect solutions I was looking for. It took a while before the Eureka moment came. Looking back, I am absolutely satisfied with the direction of solutions I took. I could have made it a lot easier if I had taken the time to have more creative and sparring sessions with medical students or experts, tough.

Since the schedule of the neurosurgeons proved a big planning issue, looking back, I would have contacted the surgeons earlier on the project so I could have made a strict planning of the using tests. This is of course subsequently speaking, I did contact the surgeons quite early in project, but maybe if I had contacted them in the very beginning of the project I would have gotten more of the results I was looking for. It could also have been a solution for me to have created a portable test setup for the neurosurgeons, instead of now creating a more realistic setup, to get more test results. I do stand behind the choice I made in this matter, the realistic take on the setup did create the right setting and gave the most reliable test results.

After the tests, it was brought to my attention that the tear trough blocking mechanism for that design might create plastic particles which could end up in the body of the patient. This is a hazard I could have noticed earlier on the project, since it's a pretty serious problem, and should have looked more critically at this design solution. Nonetheless, I did solve the problem when I stumbled upon it. The blocking mechanism was changed to a pair of snap fingers, which are not designed to break, unlike the tear through mechanism. This reduces the chance of foreign particles ending up inside the body of the patient.

During the detailing phase, I found out that the design of the twist lock mechanism could not handle the torque applied by the users, even when I used very strong materials. In retrospect, I should have tried to analyse this issue right away when connections broke during testing with the third prototype. Instead, I postponed the problem to the material selection moment. If I had made an analysis earlier on, it would have saved me a lot of stress and meetings with my coach. It also might have provided me with a more thought out solution.

15.2 CONCLUSION

The proposed spinal cage applicator, the ClearFix , fulfils the design brief stated at the start of this project, as it is able to insert the spinal cage into the intervertebral disc space in a MIS setup. However, it has only done so in a test setup which does not have a realistic insertion feedback. Participants stated that the ClearFix is easy and intuitive to use. A medical professional also stated that he would use this system if the spinal cage is tested and proven to work like the applicator.

The workflow of the ClearFix looks promising, in the way that the using of the ClearFix induces a low to moderate workload to the user. This was of course in the test setup, and not in a real surgical environment. This same test also showed that the use of the ClearFix was not without its mistakes. The source of these mistakes are not known yet. The key areas which should be improved according to the test are the connection between the spinal cage and pusher, the visibility on the surgical area, and the feedback whether the cage is place correctly.

The final design of the ClearFix presents viable solutions to tackle the issues identified in the final test with the third design. Further testing and evaluation should determine if these issues persist. The design of this product presents a promise for further development when taking the test results into account, and looking at the feedback from the medical professionals.

15.3 RECOMMENDATIONS

If the decision is made to continue working on this project, then the following recommendations should be taken into account:

Final design

The current design of the cartridge contains a blocking mechanism which has not been tested yet. It also incorporates a clear plastic with frosted markings to indicate the deployment direction. Further testing should be done to further evaluate these two aspects, since the clarity of the markings in their current form is not determined, and the force that is required to pass the blocking mechanism is only calculated. A using test might provide more details whether the feedback of the applicator is satisfactory for the user.

The applicator part is made from clear PC and bonded together using solvent bonding. The actual solvent agent is yet to be determined. An evaluation should be made to decide whether this assembly technique does not add too much stress cracking which might cause structural failure. The use of a clear plastic is also not tested yet for it's practicality, in order to know whether the material provides the surgeon with a clear view and control of the desired object, it should be tested in a real surgical environment.

The pusher design is changed as well between the third and final design. The hexagonal shape of the pusher is not yet tested with surgical gloves, or the addition of the blood and mucus which is present during the hernia surgery. The grip levels should be further tested to gain knowledge on the grip preferences of the user. The other part which has not been tested yet, is the new connection design. This new geometry should be tested for structural integrity during the intended use, and the ease of connecting and disconnecting with the spinal cage.

The spinal cage also has an updated, but still untested connection geometry. The manufacturing and structural integrity should be further investigated if the cage is to be implemented with this connection. If the spinal cage changes its design, this will affect the dimensions of the ClearFix as well. As a result of this, the ClearFix would have to be updated as well.

To have the best understanding of the state of the current design, a test should be conducted on a cadaver since this provides the most realistic anatomical test setup until human test trials are available.

Workflow

The proposed workflow has not yet proven itself in the actual surgical environment. The workflow does have a research behind it, and does look promising. Using tests focused on evaluating the workflow of the ClearFix should provide valuable feedback on whether the workflow is effective in the actual work field or should be adjusted.

Safety and approval

Before the ClearFix is allowed to be used in an actual hernia surgery, it has to comply to the set rules and regulations. A risk analysis should be performed to gain knowledge on the possibility and potential risk during the use of the ClearFix. A CE mark should be applied to the ClearFix before the applicator is ready to be launched.

Price

The manufacturing costs are calculated using several estimations. To create a more accurate calculation, it is recommended to gather quotations from material suppliers, and manufacturers. The shipping costs should also be incorporated into the calculations since these were not taken into account in this project.

16. REFERENCES

- AccuLIF Expandable TLIF and PLIF Technology Surgical Technique. (2015) (1st ed.). Retrieved from <http://wildoutwest.com/DEV/ACCULIF/assets/acculif-surgical-technique.pdf>
- CE-markering: richtlijn medische hulpmiddelen (93/42/EEG) | RVO.nl. Rvo.nl. Retrieved 17 February 2017, from <http://www.rvo.nl/onderwerpen/internationaal-ondernemen/wegwijzer-internationaal-zakendoen/eu-wetgeving/ce-markering/overzicht-ce-richtlijnen/medische-hulpmiddelen-0>
- CE-markering: stappenplan | RVO.nl. Rvo.nl. Retrieved 17 February 2017, from <http://www.rvo.nl/onderwerpen/tools/wet-en-regelgeving/eu-wetgeving/ce-markering/stappenplan>
- CES Edupack 2017 (Version 17.1.0). (2017).
- Diagnosis - Herniated disk - Mayo Clinic. (2017). [Mayoclinic.org](http://www.mayoclinic.org/diseases-conditions/herniated-disk/diagnosis-treatment/diagnosis/dxc-20271257). Retrieved 2 February 2017, from <http://www.mayoclinic.org/diseases-conditions/herniated-disk/diagnosis-treatment/diagnosis/dxc-20271257>
- Duerig, T., Pelton, A., & Stöckel, D. (1999). An overview of nitinol medical applications. *Materials Science And Engineering: A*, 273-275, 149-160. [http://dx.doi.org/10.1016/s0921-5093\(99\)00294-4](http://dx.doi.org/10.1016/s0921-5093(99)00294-4)
- DuPont. Tyrek peel pouch. Retrieved from http://images.protectiontechnologies.dupont.com/Eloqualimages/clients/DuPontInternationalOperationsSarI/%7b451211d0-c29e-4c04-a2d3-401e8ece5e41%7d_DMP_Tyvek_Photo_MPTP_Package_Test_Results_Selector_Tool_Hero.jpg
- Ebay. Lathe. Retrieved from <http://images.esellerpro.com/2697/1/753/246/SM27.V2.jpg>
- EU-landen: CE-markering | RVO.nl. Rvo.nl. Retrieved 17 February 2017, from <http://www.rvo.nl/onderwerpen/tools/wet-en-regelgeving/eu-wetgeving/ce-markering>
- European Union. (2017). REGULATION (EU) 2017/745 OF THE EUROPEAN PARLIAMENT AND OF THE COUNCIL.
- Expanding Orthopedics FLXfit 3D expandable cage. (2016). Retrieved from <https://www.youtube.com/watch?v=uwRSbBX0WbM>
- Florida Hospital Medical Group,. Minimally Invasive Posterior Lumbar Interbody Fusion (PLIF). Retrieved from <http://www.thespinehealthinstitute.com/minimally-invasive-posterior-lumbar-interbody-fusion-plif>
- Gaillard, F., & Knipe, H. Annulus fibrosus | Radiology Reference Article | Radiopaedia.org. Radiopaedia.org. Retrieved 28 April 2017, from <https://radiopaedia.org/articles/annulus-fibrosus>
- Gawande, A., Zinner, M., Studdert, D., & Brennan, T. (2003). Analysis of errors reported by surgeons at three teaching hospitals. *Surgery*, 133(6), 614-621. <http://dx.doi.org/10.1067/msy.2003.169>
- Gilbert, D., Dibb, W., Plath, L., & Hiyane, S. (2000). Effects of nicotine and caffeine, separately and in combination, on EEG topography, mood, heart rate, cortisol, and vigilance. *Psychophysiology*, 37, 583-595.
- Hart, S.G., & Staveland, L.E. (1988) Development of NASA-TLX (Task Load Index): results of empirical and theoretical research. *Adv Psychol* 52:139-183.
- Herniated Disk in the Lower Back-OrthoInfo - AAOS. (2017). [Orthoinfo.aaos.org](http://orthoinfo.aaos.org). Retrieved 31 January 2017, from <http://orthoinfo.aaos.org/topic.cfm?topic=a00534>
- How to prevent stress cracking - Permabond. Permabond. Retrieved 10 October 2017, from <http://www.permabond.com/2017/04/20/prevent-stress-cracking/>
- Jason M. Highsmith, M. (2017). Herniated Disc Symptoms. SpineUniverse. Retrieved 31 January 2017, from <https://www.spineuniverse.com/conditions/herniated-disc/symptoms-herniated-disc>
- Jones, K., Amawi, F., Bhalla, A., Peacock, O., Williams, J., & Lund, J. (2015). Assessing surgeon stress when operating using heart rate variability and the State Trait Anxiety Inventory: will surgery be the death of us?. *Colorectal Disease*, 17(4), 335-341. <http://dx.doi.org/10.1111/codi.12844>
- Karwowski, W. (2006). International encyclopedia of ergonomics and human factors (p. 1431). London [u.a.]: Taylor & Francis.
- Kim, Y., & Hyun, S. (2007). Clinical Applications of the Tubular Retractor on Spinal Disorders. *Journal Of Korean Neurosurgical Society*, 42(4), 245. <http://dx.doi.org/10.3340/jkns.2007.42.4.245>
- lumbar. (2013). Yellowsteps.net. Retrieved 13 February 2017, from <https://www.yellowsteps.net/en/our-products/lumbar/>
- Lumbar Herniated Disc. (2017). University of Maryland Medical Center. Retrieved 31 January 2017, from <http://umm.edu/programs/spine/health/guides/lumbar-herniated-disc>
- Lumbar Herniated Disc Video. (2017). Spine-health. Retrieved 31 January 2017, from <http://www.spine-health.com/video/lumbar-herniated-disc-video>
- Luna 3D interbody fusion system (1st ed.). Retrieved from http://benvenuemedical.com/wp-content/uploads/2016/09/Luna_IFU_LS3605C.pdf
- Luna 3D Interbody Fusion System. (2017). Benvenuemedical.com. Retrieved 13 February 2017, from <https://benvenuemedical.com/products/luna-360-interbody-system/>

- Lundberg, U., Dohns, I., Melin, B., Sandsjö, L., Palmerud, G., & Kadefors, R. et al. (1999). Psychophysiological stress responses, muscle tension, and neck and shoulder pain among supermarket cashiers. *Journal Of Occupational Health Psychology*, 4(3), 245-255. <http://dx.doi.org/10.1037//1076-8998.4.3.245>
- Made-in-china. (2017). Hexagonal bars. Retrieved from <http://image.made-in-china.com/2f0j00UjHQNqCRszrg/AISI-304-Stainless-Steel-Hexagonal-Bar.jpg>
- Medical devices - Groei - European Commission. (2017). Groei. Retrieved 26 January 2017, from https://ec.europa.eu/growth/single-market/european-standards/harmonised-standards/medical-devices_nl
- Medicrea impix-tlif. (2017). Medicrea.com. Retrieved 13 February 2017, from <http://www.medicrea.com/en/th-lumbar-range/impix-tlif/>
- Metals, A. (2001). Stainless Steel - Grade 420 (UNS S42000). AZoM.com. Retrieved 7 February 2017, from <http://www.azom.com/article.aspx?ArticleID=972>
- METRx system Surgical technique. (2009).
- Modjarrad, K. & Ebnesajjad, S. (2013). Handbook of polymer applications in medicine and medical devices (1st ed.).
- NDIndustries. Bolts with locking agent. Retrieved from <https://www.ndindustries.com/wp-content/uploads/expand-a-lock-01.jpg>
- Pathway AVID Surgical Technique (1st ed.). Retrieved from <http://activize.com/wp-content/uploads/2014/05/AVID-Surgical-Protocol.pdf>
- Peter F. Ullrich, O. (2017). Spinal Cord and Spinal Nerve Roots. Spine-health. Retrieved 31 January 2017, from <http://www.spine-health.com/conditions/spine-anatomy/spinal-cord-and-spinal-nerve-roots>
- Philip R. Shalen, M. (2017). Lumbar Discogram Procedure. Spine-health. Retrieved 2 February 2017, from <http://www.spine-health.com/treatment/diagnostic-tests/lumbar-discogram-procedure>
- PROW FUSION™ | NLT SPINE. Nlt-spine.com. Retrieved 13 February 2017, from <http://www.nlt-spine.com/int/fusion/PROW-FUSION/>
- Ries, E. (2011). The lean startup. Penguin Books Ltd.
- Robergs, R., & Landwehr, R. (2002). The surprising history of the “HRmax=220 - age” equation. *Journal Of Exercise Physiology*, 5(2).
- Roozenburg, N. and Eekels, J. (2003). Productontwerpen, structuur en methoden. Utrecht: Lemma.
- ruggenmerg, W. (2017). Rughernia - NVvN. Nvvn.org. Retrieved 31 January 2017, from <http://www.nvvn.org/patienteninfo/wervelkolom-en-ruggenmerg/rughernia/>
- S.M. Fox, W.L. Haskell. The exercise stress test: needs for standardization, M. Eliakim, H.N. Neufeld. *Cardiology: Current Topics and Progress*. 6th ed. New York: Academic Press; 1970. p. 149-154
- Sastri, V. R. (2010). *Plastics in medical devices : properties, requirements and applications PDL handbook series; PDL handbook series.*, Retrieved from Books24x7 <http://www.books24x7.com/marc.asp?bookid=36333>
- Schwender, J., Holly, L., Rouben, D., & Foley, K. (2005). Minimally Invasive Transforaminal Lumbar Interbody Fusion (TLIF). *Journal Of Spinal Disorders & Techniques*, 18(Supplement 1), S1-S6. <http://dx.doi.org/10.1097/01.bsd.0000132291.50455.d0>
- Sharek, D. (2009). NASA-TLX Online Tool (Version 0.06) [Internet Application]. Nasatlx.com. Retrieved 6 September 2017, from <http://www.nasatlx.com/>
- Shen, F., Samartzis, D., Khanna, A., & Anderson, D. (2007). Minimally Invasive Techniques for Lumbar Interbody Fusions. *Orthopedic Clinics Of North America*, 38(3), 373-386. <http://dx.doi.org/10.1016/j.jocl.2007.04.002>
- Shen, F., Samartzis, D., Khanna, A., & Anderson, D. (2007). Minimally Invasive Techniques for Lumbar Interbody Fusions. *Orthopedic Clinics Of North America*, 38(3), 373-386. <http://dx.doi.org/10.1016/j.jocl.2007.04.002>
- Shim, J., Huang, J., Hooke, A., latash, M., & Zatsiorsky, V. (2007). Multi-digit maximum voluntary torque production on a circular object. *Ergonomics*, 50(5), 660-675. <http://dx.doi.org/10.1080/00140130601164516>
- Shunwu, F., Xing, Z., Fengdong, Z., & Xiangqian, F. (2010). Minimally Invasive Transforaminal Lumbar Interbody Fusion for the Treatment of Degenerative Lumbar Diseases. *Spine*, 35(17), 1615-1620. <http://dx.doi.org/10.1097/brs.0b013e3181c70fe3>
- Stainless Steel - Grade 316 (UNS S31600). (2001). AZoM.com. Retrieved 7 February 2017, from <http://www.azom.com/article.aspx?ArticleID=863>
- Stainless Steel - Grade 440 (UNS S44000). (2001). AZoM.com. Retrieved 7 February 2017, from <http://www.azom.com/article.aspx?ArticleID=1024>
- Sterile Packaging | DuPont™ Tyvek®— Medical and Pharmaceutical | DuPont USA. (2017). Dupont.com. Retrieved 10 October 2017, from <http://www.dupont.com/products-and-services/packaging-materials-solutions/pharmaceutical-packaging/brands/tyvek-sterile-packaging.html>

- Sterilization Pouches | DuPont™ Tyvek® | DuPont USA. (2017). Dupont.com. Retrieved 10 October 2017, from <http://www.dupont.com/products-and-services/packaging-materials-solutions/pharmaceutical-packaging/brands/tyvek-sterile-packaging/uses-and-applications/protective-clean-peel-pouches.html>
- T-PAL Surgical Technique. (2016) (1st ed.).
- T-PAL Surgical Technique. (2016) (1st ed.). Retrieved from http://synthes.vo.llnwd.net/o16/LLNWMB8/INT%20Mobile/Synthes%20International/Product%20Support%20Material/legacy_Synthes_PDF/DSEM-SPN-0714-0145-1_LR.pdf
- T-PLIF Minimally Invasive and Auxiliary Instruments Technical Guide. (2004) (1st ed.).
- Tague, N. (2005). *The Quality Toolbox*. Milwaukee: ASQ Quality Press.
- The staxx family of expandable devices. (2013) (1st ed.). Retrieved from <http://www.spartanmedspine.com/spinal-technology/pdf/SM-StaXx-Family.pdf>
- Titanium Alloys - Ti6Al4V Grade 5. (2002). AZoM.com. Retrieved 7 February 2017, from <http://www.azom.com/article.aspx?ArticleID=1547>
- Tungsten Carbide - An Overview. (2002). AZoM.com. Retrieved 7 February 2017, from <http://www.azom.com/article.aspx?ArticleID=1203>
- van Veelen, M., Jakimowicz, J., & Kazemier, G. (2004). Improved physical ergonomics of laparoscopic surgery. *Minimally Invasive Therapy & Allied Technologies*, 13(3), 161-166. <http://dx.doi.org/10.1080/13645700410033193>
- Which Alloy is Best for My Surgical Instruments?. (2013). Wpiinc.com. Retrieved 7 February 2017, from <https://www.wpiinc.com/blog/2013/04/30/article/which-alloy-is-best-for-my-surgical-instruments/>
- Wiltfong, R., Bono, C., Charles Malveaux, W., & Sharan, A. (2012). Lumbar interbody fusion. *Current Orthopaedic Practice*, 23(3), 193-202. <http://dx.doi.org/10.1097/bco.0b013e318231c2ad>
- xtant medical (n.d.). PEEK spinal cages. [image] Available at: <https://xtantmedical.com/app/uploads/2017/01/Calix-ATP-PC.jpg> [Accessed 2 Nov. 2017].
- Yeung, A. & Yeung, C. (2007). Minimally Invasive Techniques for the Management of Lumbar Disc Herniation. *Orthopedic Clinics Of North America*, 38(3), 363-372. <http://dx.doi.org/10.1016/j.ocl.2007.04.005>

