

MATERIAL VAULT

Library of Materials

Kalina Matova

07/11/2024

- 01 **INTRODUCTION**
- 02 LIBRARY
- 03 DESIGN BRIEF
- 04 DESIGN CONCEPT
- 05 DESIGN IMPLEMENTATION
- 06 CONCLUSION







introduction

RESOURCE DEPLETION

We're using 73% more resources than the Earth can renew.



<https://www.forbes.com/sites/johndobosz/2023/09/30/billionaire-stocks-for-an-october-market-rebound/>

RESOURCE DEPLETION

We're using 73% more resources than the Earth can renew.



= 1.7 Earths annually.

<https://www.forbes.com/sites/johndobosz/2023/09/30/billionaire-stocks-for-an-october-market-rebound/>

RESOURCE DEPLETION

We're using 73% more resources than the Earth can renew.

We must rethink resource usage and innovate materials.



= 1.7 Earths annually.

<https://www.forbes.com/sites/johndobosz/2023/09/30/billionaire-stocks-for-an-october-market-rebound/>

GROUP REQUIREMENTS



DEVELOPMENT AREAS

- I. Buch, Buchholz Nord
- II. Pankow, Blankenburg, Karow
- III. TXL, Siemensstadt, Spandau
- IV. Nordring, Wedding
- V. Marzahn, Hellersdorf
- VI. Cityband, betw. East & West
- VII. Südkreuz, Tempelhof
- VIII. Südring, NeuKöln
- IX. Obere Spree
- X. BER, Brandenburg

LEGEND

- Railway
- Station
- + Railway yard (r = 3000M)
- Dockyard (r = 3000M)
- Water
- ▨ Development area
- - - 15 minute isochrone from Berlin Hbf.

Group work done with Material group

introduction

PERSONAL AMBITION



make use of
**existing building
stock** through
adaptive reuse

Vacant NL - Dutch pavilion at Venice Biennale, 2010
<https://www.designboom.com/>

MATERIAL DEVELOPMENTS



Carmody Groarke - Waste Brick

locally sourced municipal waste streams (concrete and glass)

<https://carmodygroarke.com/work/gent-waste-brick>

MATERIAL DEVELOPMENTS



Studio RAP - Ceramic House

3D printed ceramic tiles, algorithmic design and artisanal glazing.

EXISTING (DIGITAL) PLATFORMS



Sitterwerk Katalog

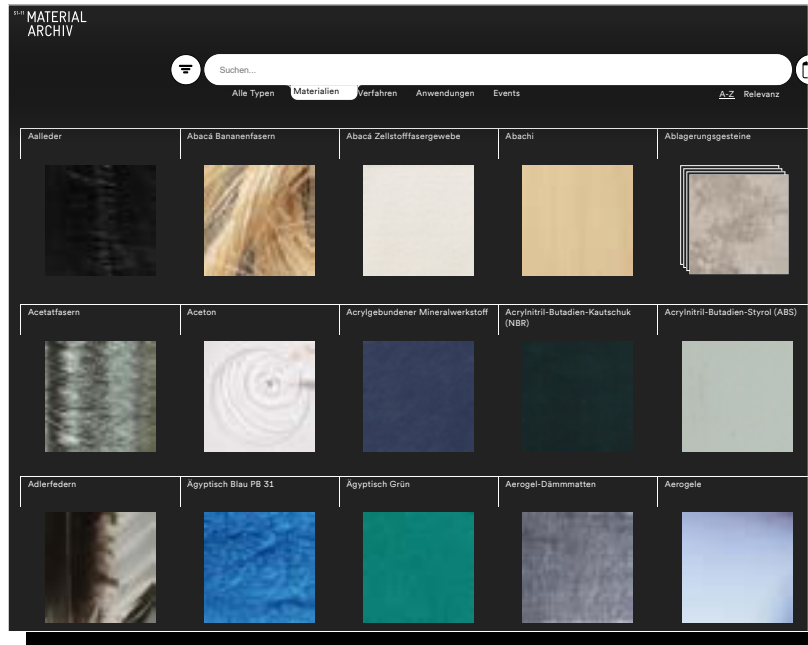

Material Archiv

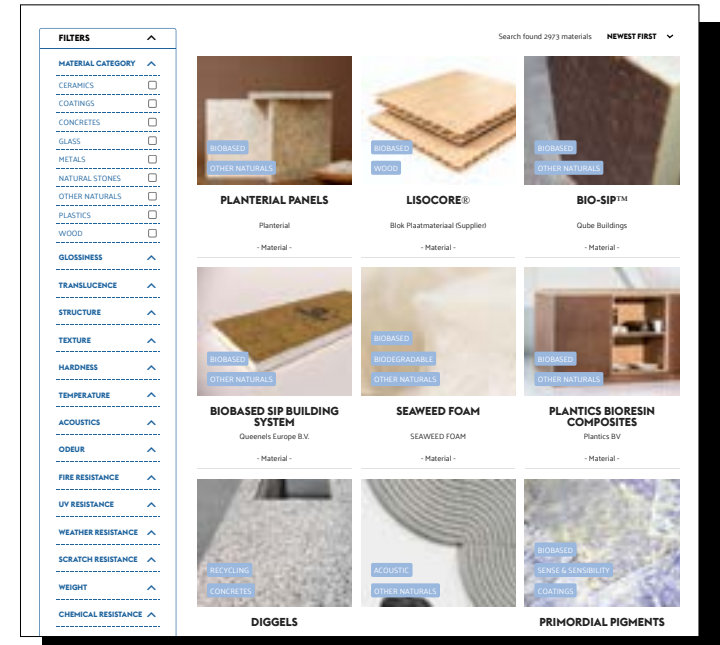

Material District

introduction

OUR CATALOG

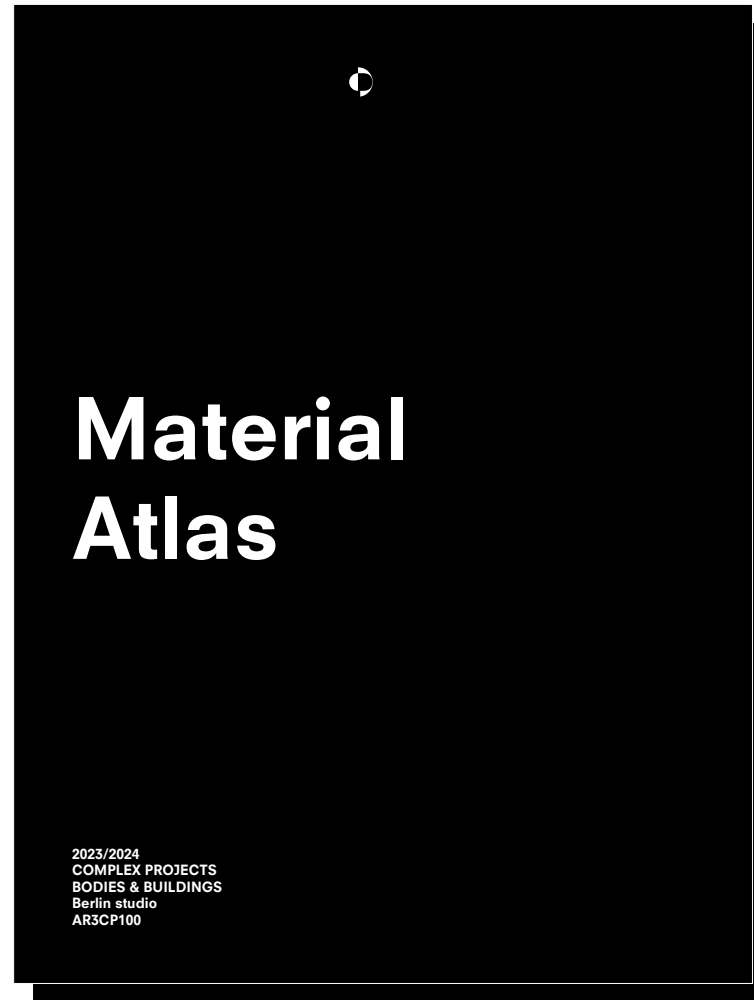

Group work done with Material group

OUR CATALOG

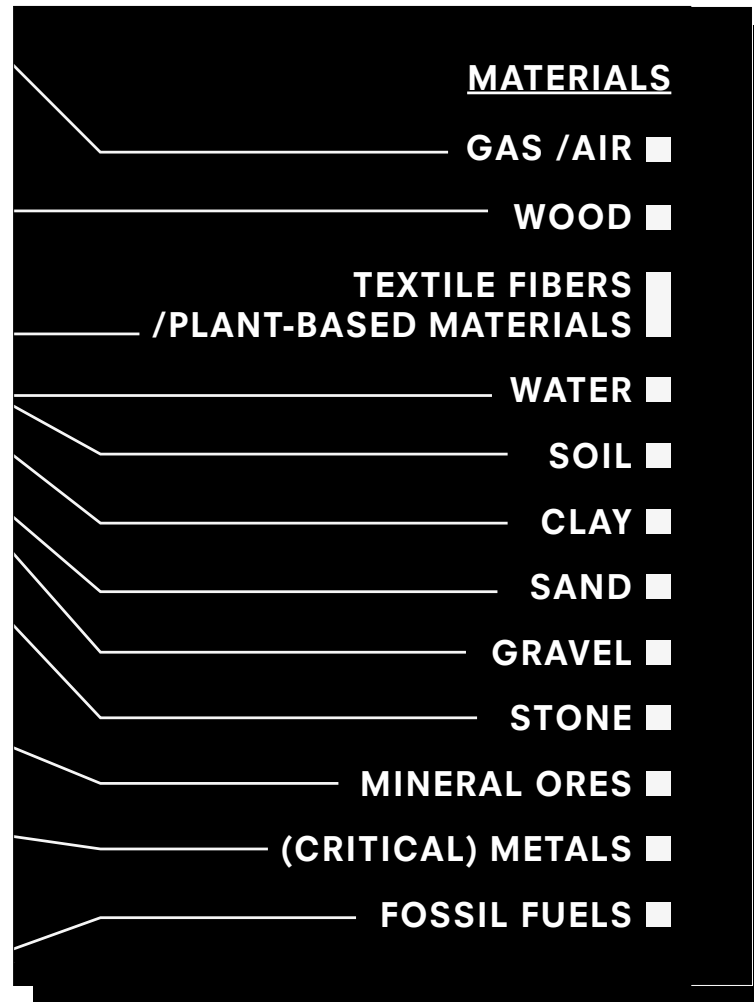

introduction

OUR CATALOG

2.1 - WOOD - VISUAL OVERVIEW

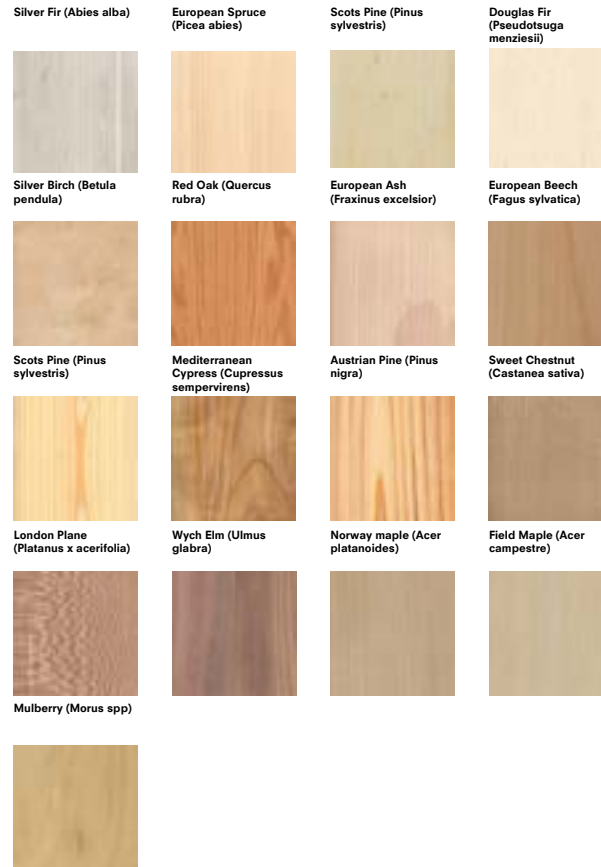

46

introduction

PHYSICAL CATALOG



- 01 INTRODUCTION
- 02 LIBRARY**
- 03 DESIGN BRIEF
- 04 DESIGN CONCEPT
- 05 DESIGN IMPLEMENTATION
- 06 CONCLUSION

library

THE LIBRARY AS A DYING TYPOLOGY



library

DEFINITION

Library

[li·brer·e] noun

- ^{1a} a **place in which** literary, musical or artistic **materials** (such as books, manuscripts, recordings, or films) **are kept for use**
- ^{1b} a **collection** of such materials
- ² a **room** in a person's house **where books are kept**
- ³ a **collection** of publications on the same subject
-

Synonym

archive

¹ <https://www.merriam-webster.com/dictionary/library>
² <https://www.britannica.com/dictionary/library>



Synonym

archive

1 <https://www.merriam-webster.com/dictionary/library>
2 <https://www.britannica.com/dictionary/library>

the library of the present
DIGITAL THREAT

FORBES > INNOVATION > ENTERPRISE & CLOUD

Librarians Against The Machines: Is ChatGPT The Incarnation Of EMERAC?

Gil Press Senior Contributor

I write about technology, entrepreneurs and innovation.

Apr 30, 2023, 04:08pm EDT

“They can’t build a machine to do our job; there are too many cross-references in this place,” the head librarian (Katharine Hepburn) tells her anxious colleagues in the research department when a “methods engineer” (Spencer Tracy) is hired to “improve workman-hour relationship” in a large corporation.



The library at Harvard Medical School, part of Harvard University in Boston, Massachusetts, 9th ... [+] GETTY IMAGES

<https://www.forbes.com/sites/johndobosz/2023/09/30/billionaire-stocks-for-an-october-market-rebound/>

the library of the present

LIBRARY VISITS PER YEAR IN DE

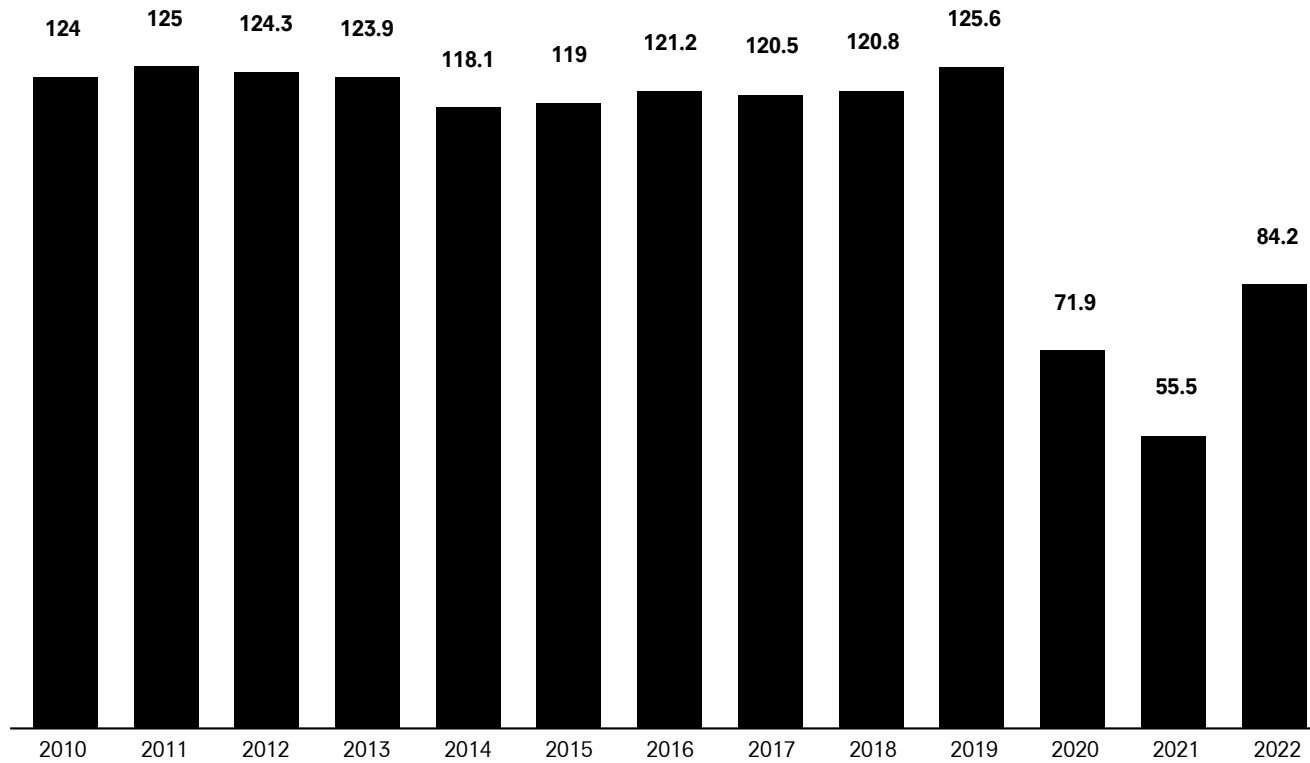

<https://www.statista.com/statistics/1335836/public-libraries-visits-number-germany/>

BRITISH LIBRARY AT BOSTON SPA



Kaupunkiverstas
Cityverkstaden
Urban workshop

OODI HELSINKI LIBRARY



JUSSIEU - TWO LIBRARIES (OMA)

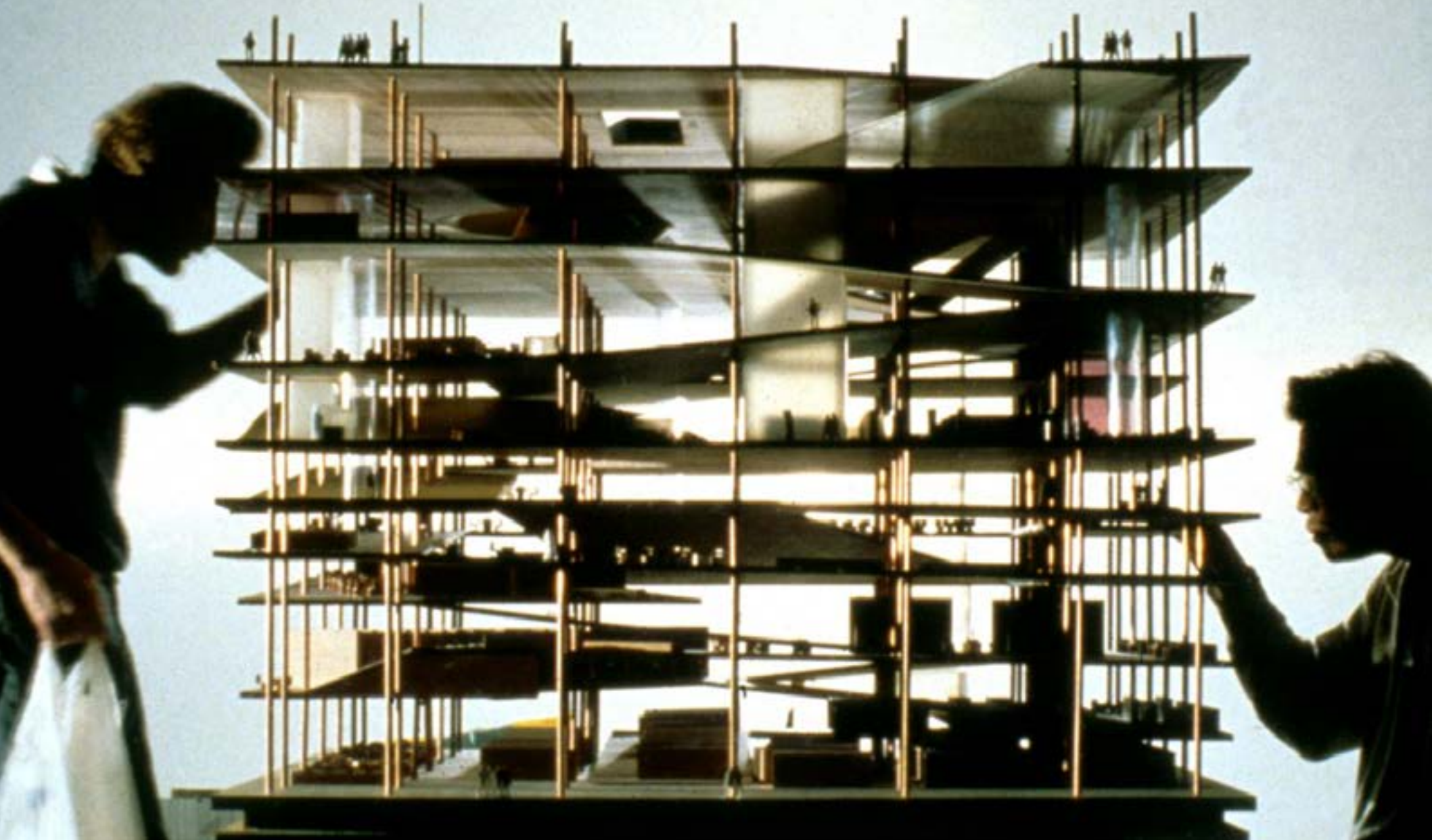

STAATSBIBLIOTEK UNTER DEN LINDEN

STAATSBIBLIOTEK UNTER DEN LINDEN

STATIC

QUIET

BORING

STAATSBIBLIOTEK UNTER DEN LINDEN

**CHANGING
LOUD
COLLABORATIVE**

BK WORKSHOP

the solution

LIBRARY OF MATERIALS

PAST



collection of books
and materials

PRESENT



showroom with
innovative materials

FUTURE



scientific research
center of materials

the solution

RESEARCH QUESTION



Can libraries become future-proof promoters of sharing and creating knowledge through the curation of materials and adaptive reuse strategies?

- 01 INTRODUCTION
- 02 LIBRARY
- 03 DESIGN BRIEF**
- 04 DESIGN CONCEPT
- 05 DESIGN IMPLEMENTATION
- 06 CONCLUSION

01 INTRODUCTION

02 LIBRARY

03 **DESIGN BRIEF**

SITE

CLIENT

PROGRAM

SITE

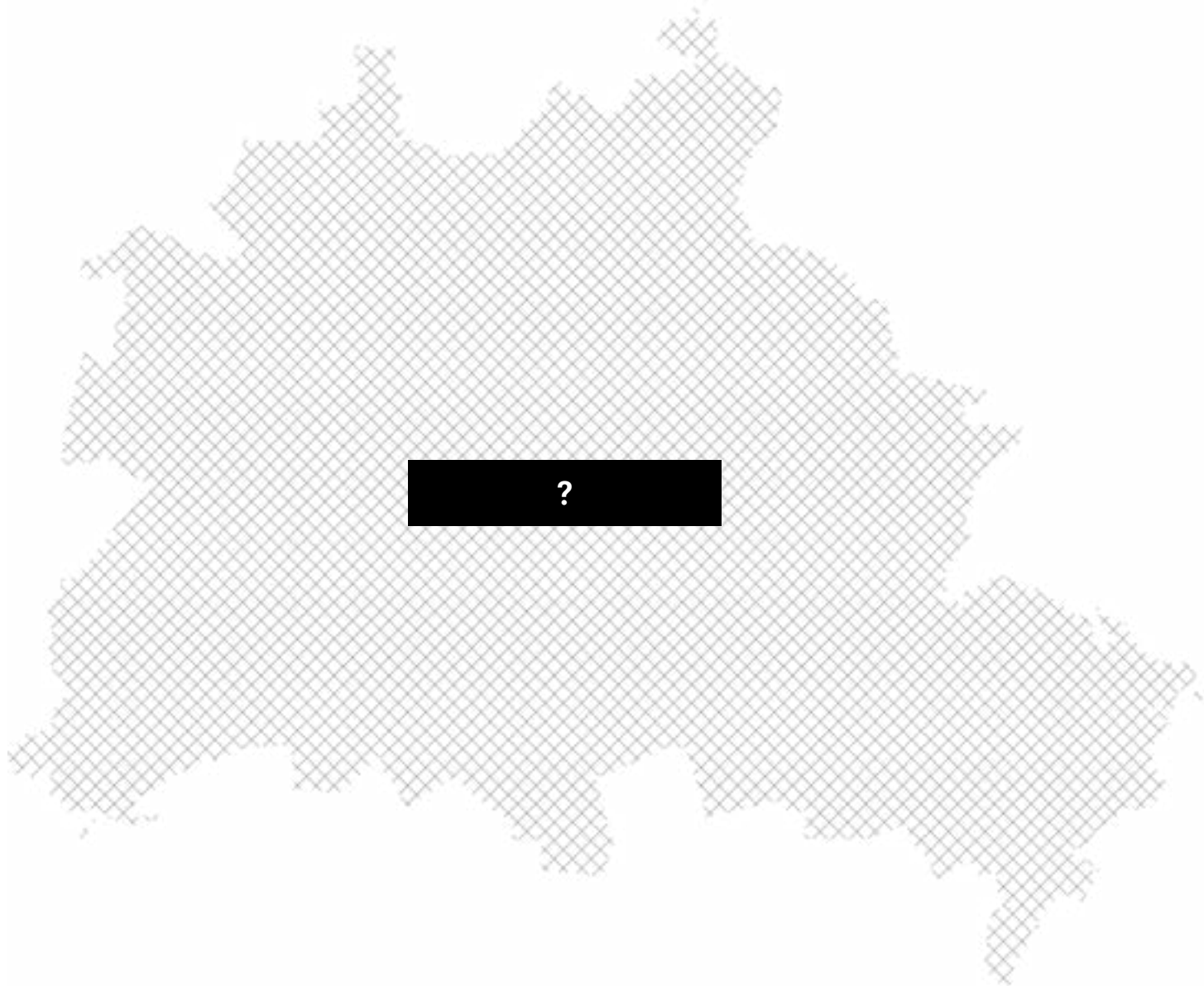

EVALUATION MATRIX

	historical	use/re-use	prominence	culture	rarity
CONTEXT					
SITE					
STRUCTURE					
SPACE PLAN					
SPIRIT OF PLACE					

EVALUATION MATRIX

	historical	use/re-use	prominence	culture	rarity
CONTEXT					
SITE					
STRUCTURE					
SPACE PLAN					
SPIRIT OF PLACE					

site selection

LIBRARY OF HUMBOLDT-UNIVERSITÄT

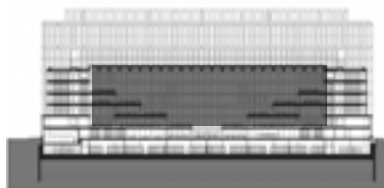
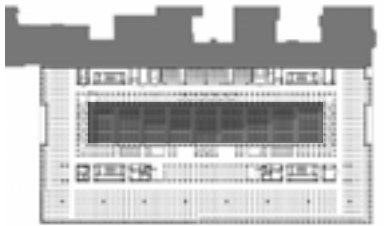

site selection

STAATSBIBLIOTHEK POSTDAMER PLATZ



site selection

STAATSBIBLIOTHEK UNTER DEN LINDEN

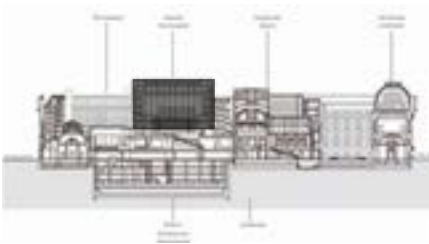
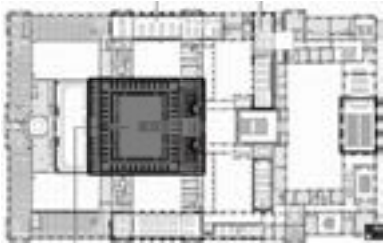

3 SITES

HAUS DER STATISTIK

GASOMETER

ABHÖRSTATION

	historical	use/re-use	prominence	culture	rarity	historical	use/re-use	prominence	culture	rarity	historical	use/re-use	prominence	culture	rarity	
CONTEXT																
SITE																
STRUCTURE																
SPACE PLAN																
SPIRIT OF PLACE																



evaluation matrix

3 SITES

HAUS DER STATISTIK

GASOMETER

ABHÖRSTATION

	historical	use/re-use	prominence	culture	rarity	historical	use/re-use	prominence	culture	rarity	historical	use/re-use	prominence	culture	rarity
CONTEXT	+		+		+	+	+	+			+	+	+	+	
SITE	+	+	+	+		+	+	+	+	+	+	+	+	+	+
STRUCTURE	+	+				+	+	+		+	+		+		+
SPACE PLAN		+				+	+	+	+						+
SPIRIT OF PLACE	+		+			+	+	+	+	+	+		+		



evaluation matrix

3 SITES

HAUS DER STATISTIK

GASOMETER

ABHÖRSTATION

	historical	use/re-use	prominence	culture	rarity	historical	use/re-use	prominence	culture	rarity	historical	use/re-use	prominence	culture	rarity
CONTEXT	+		+		+	+	+	+			+	+	+	+	
SITE	+	+	+	+		+	+	+	+	+	+	+	+	+	+
STRUCTURE	+	+				+	+	+		+	+		+		+
SPACE PLAN		+				+	+	+	+						+
SPIRIT OF PLACE	+		+			+	+	+	+	+	+		+		

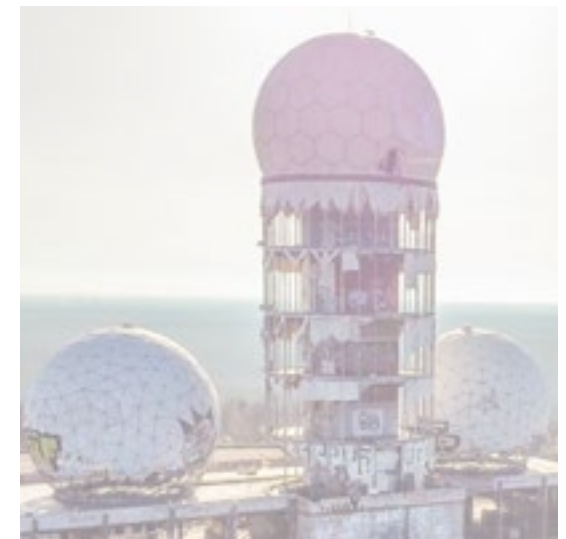

wider Berlin

LIBRARIES - PUBLIC

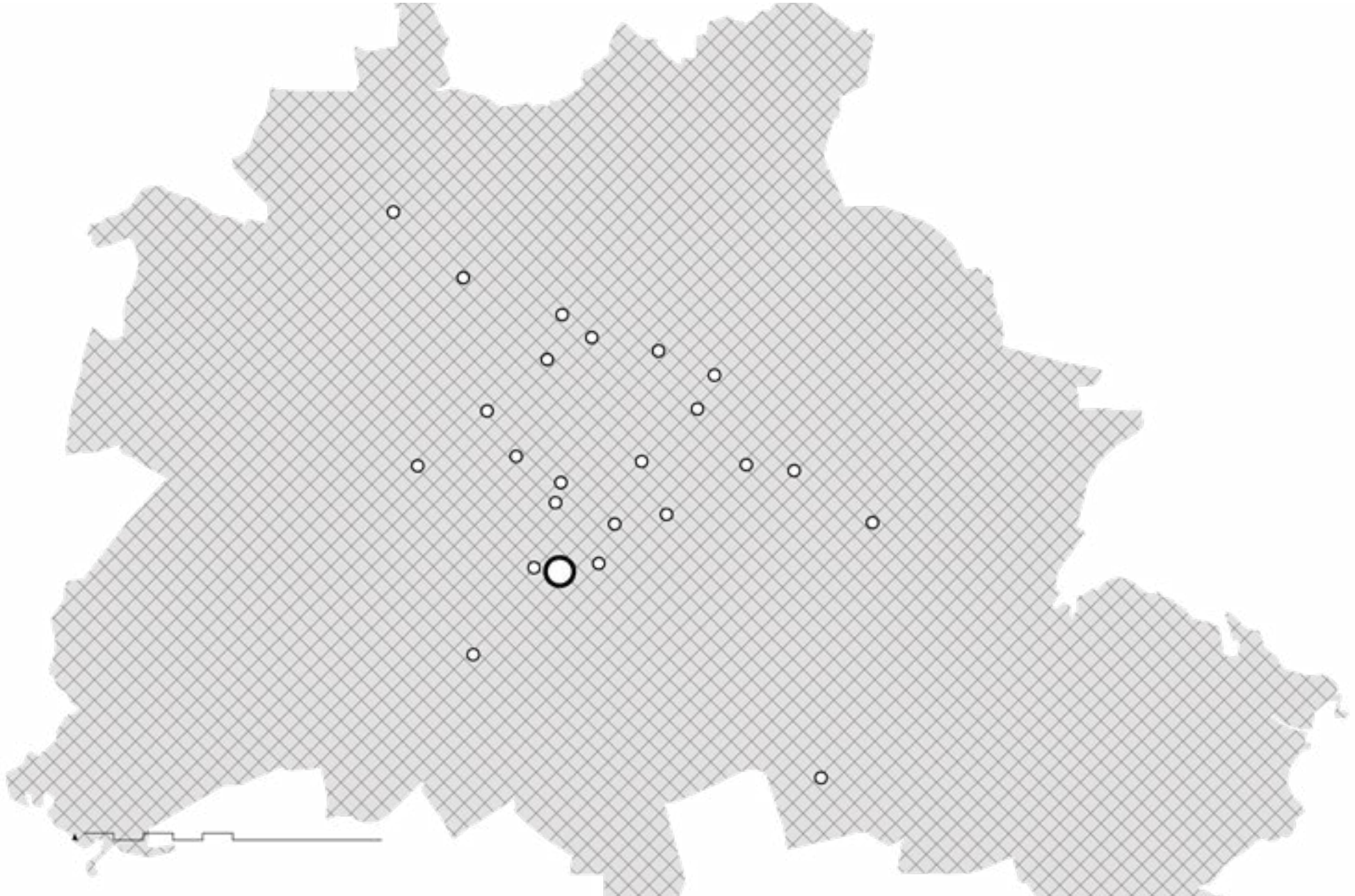

wider Berlin

LIBRARIES - ACADEMIC

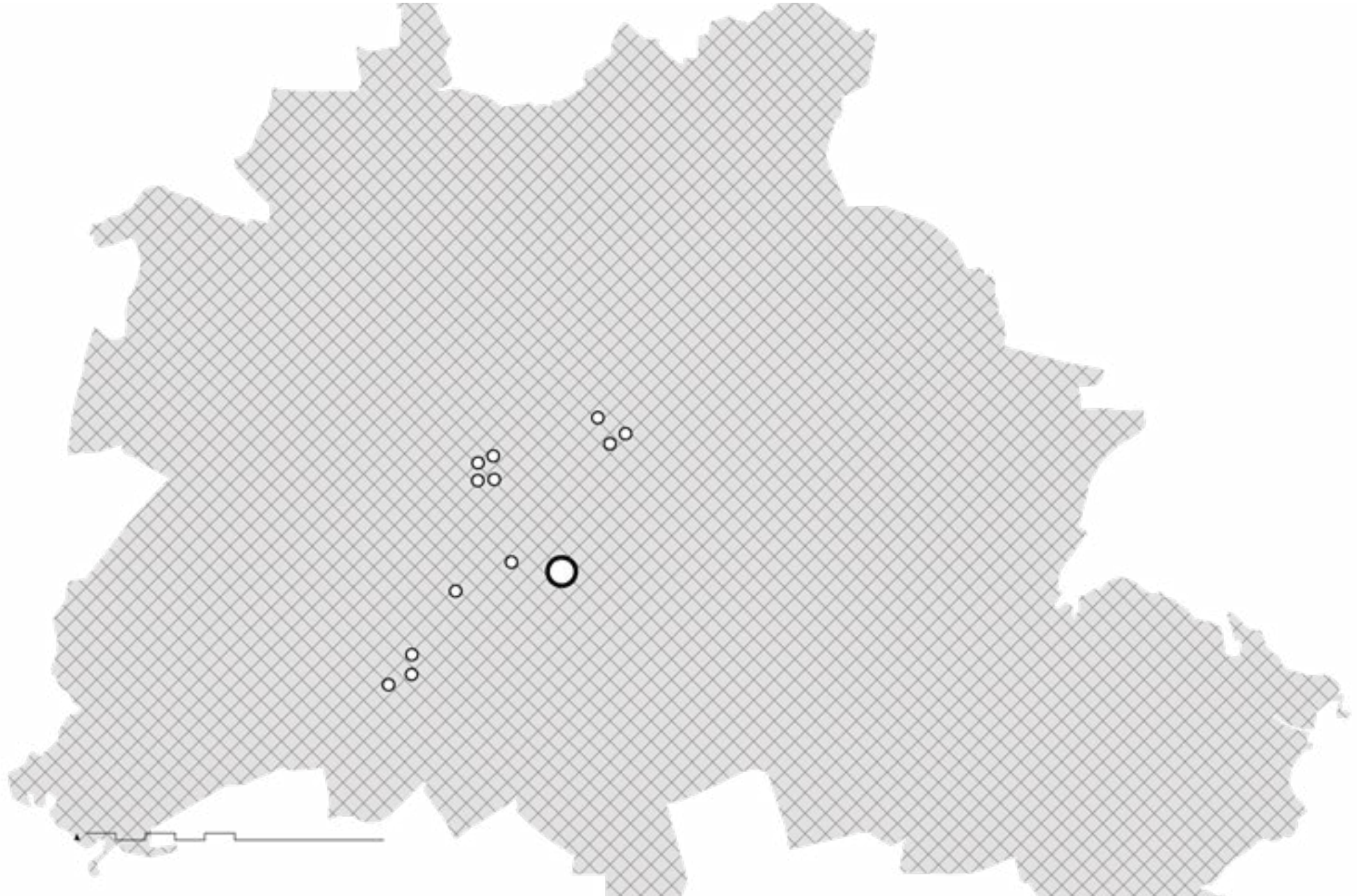

wider Berlin

LIBRARIES - STATE

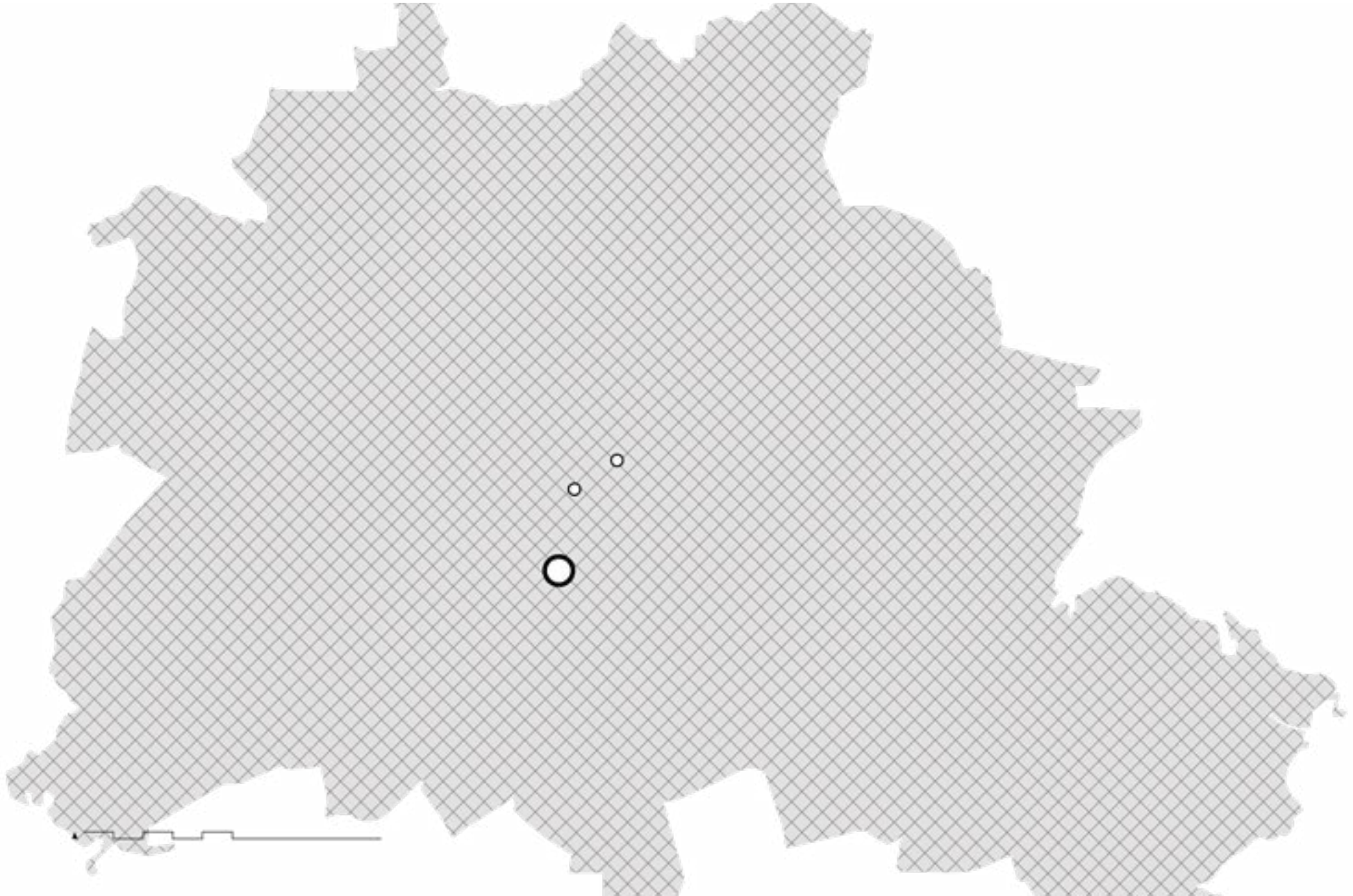

wider Berlin
LIBRARIES

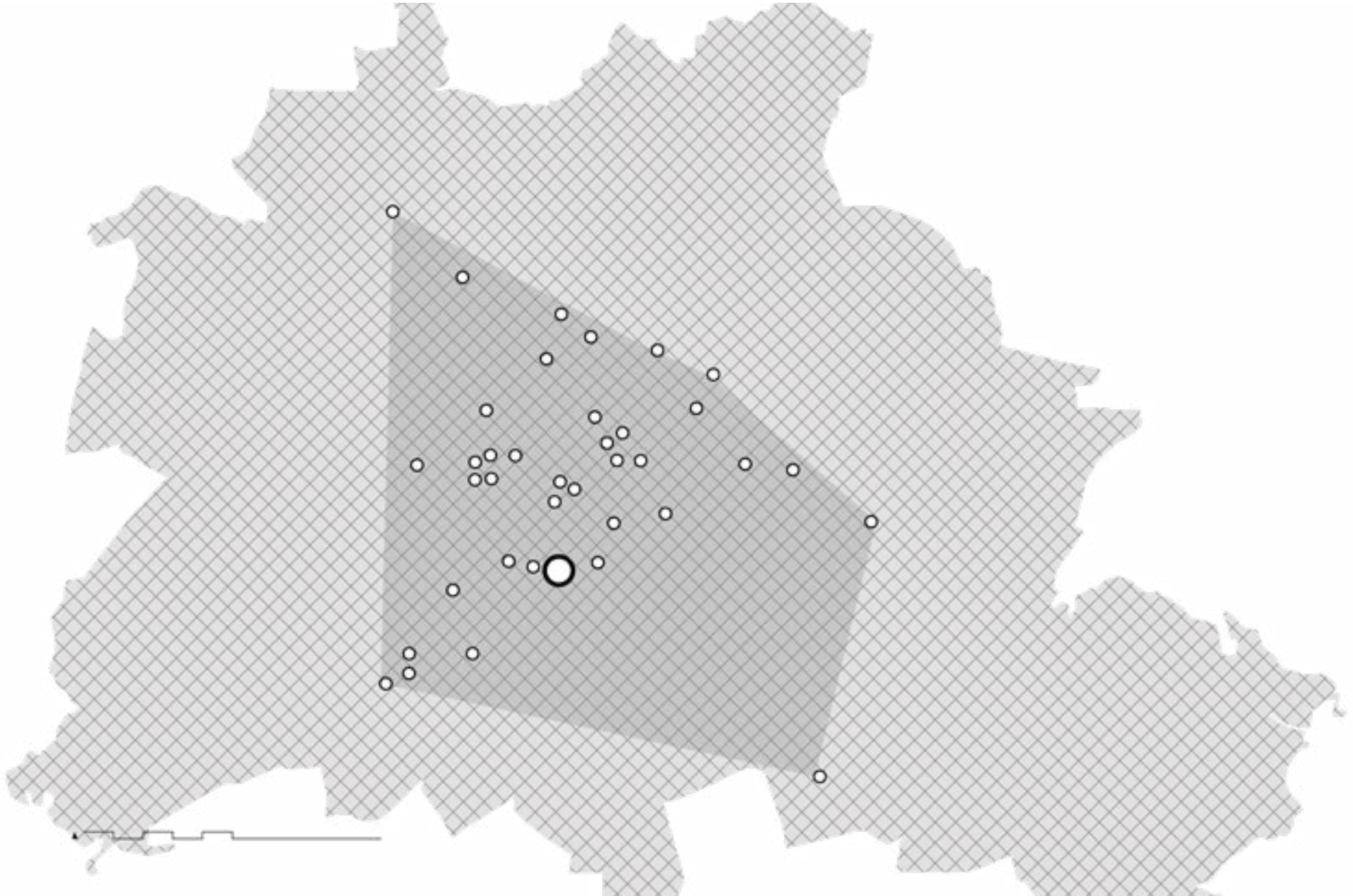

wider Berlin

CAMPUSES

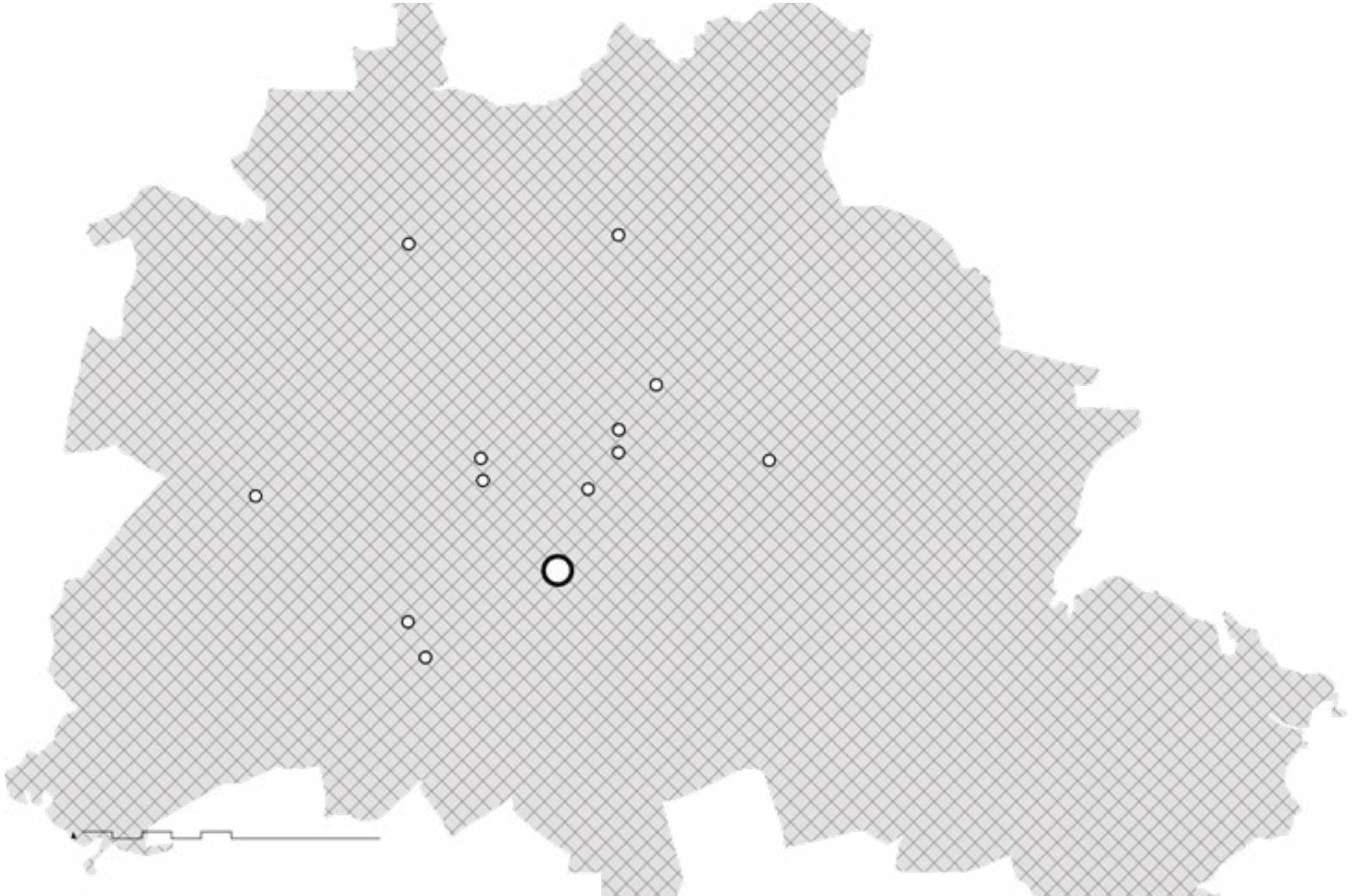

wider Berlin

CAMPUSES

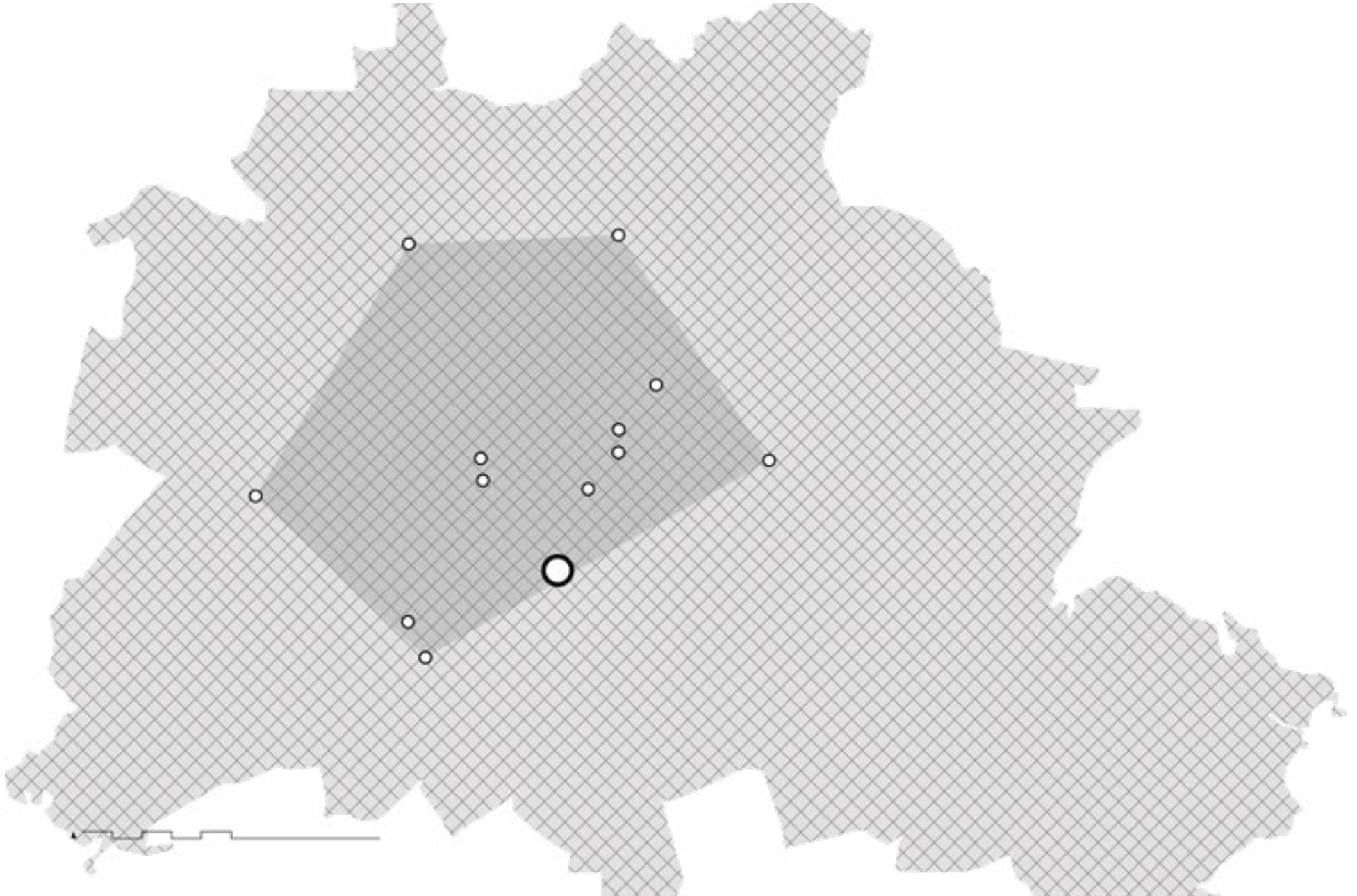

wider Berlin

LIBRARIES + CAMPUSES

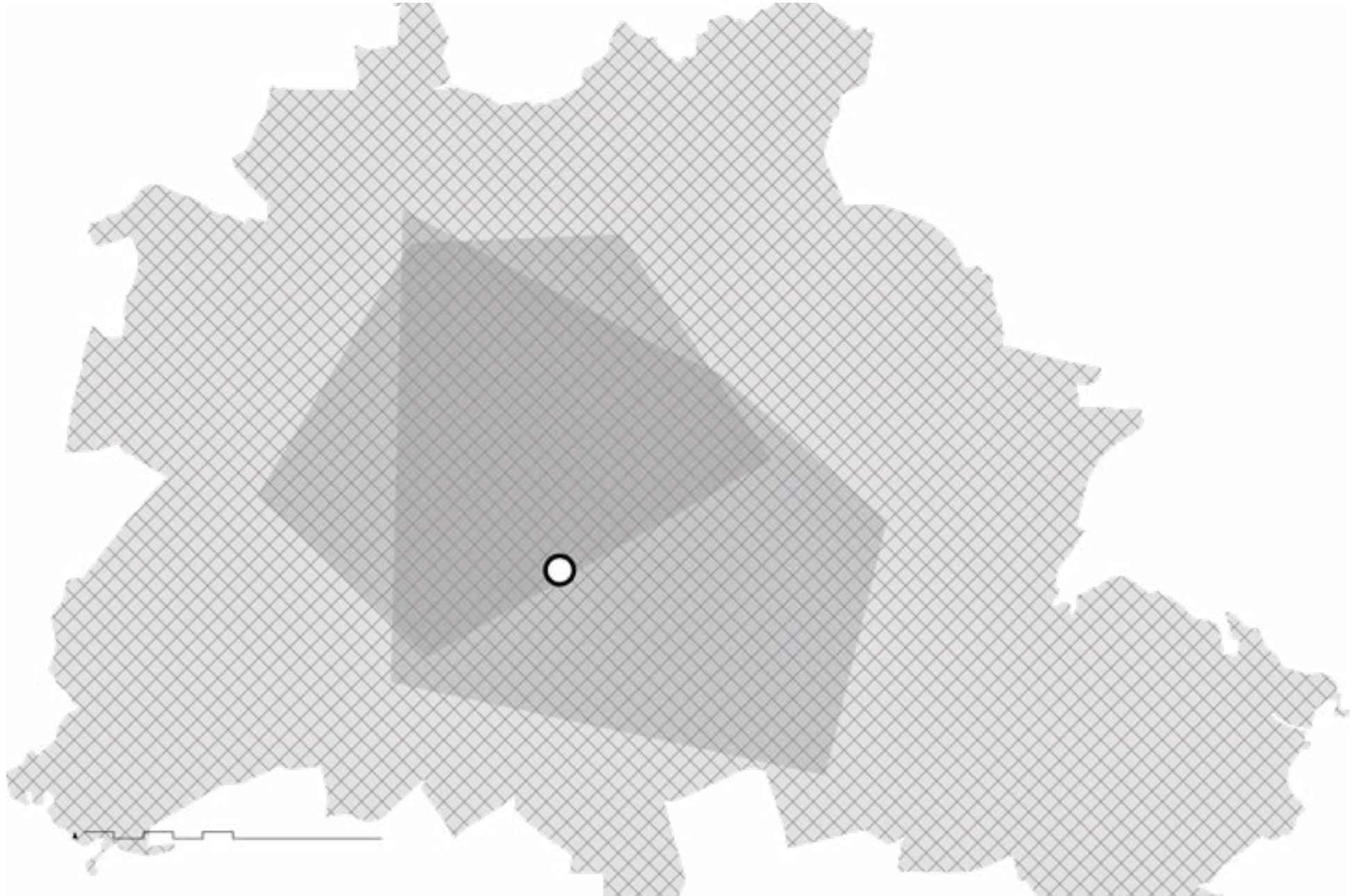

wider Berlin

CLIENT HEADQUARTERS

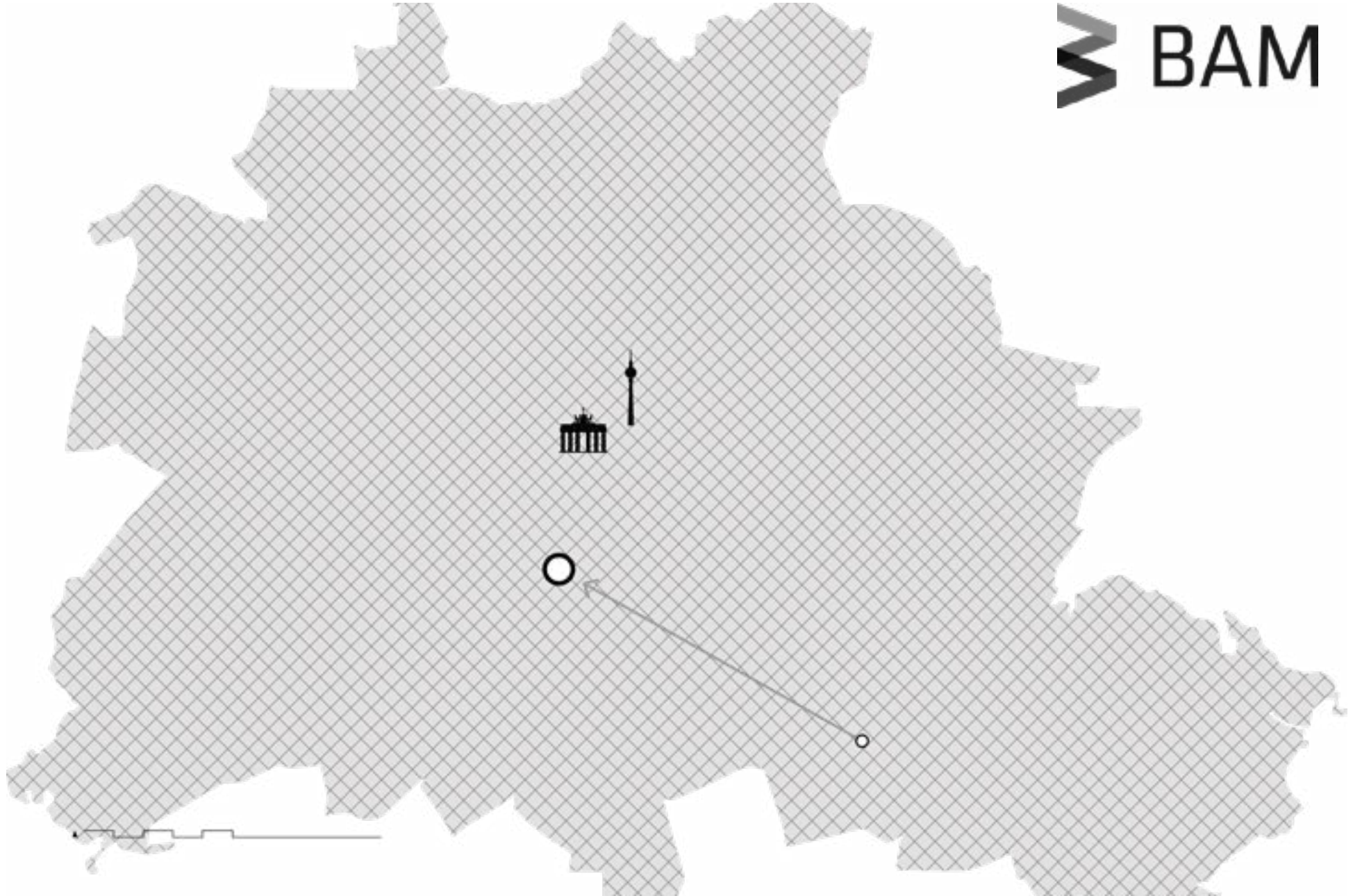

situation HISTORY

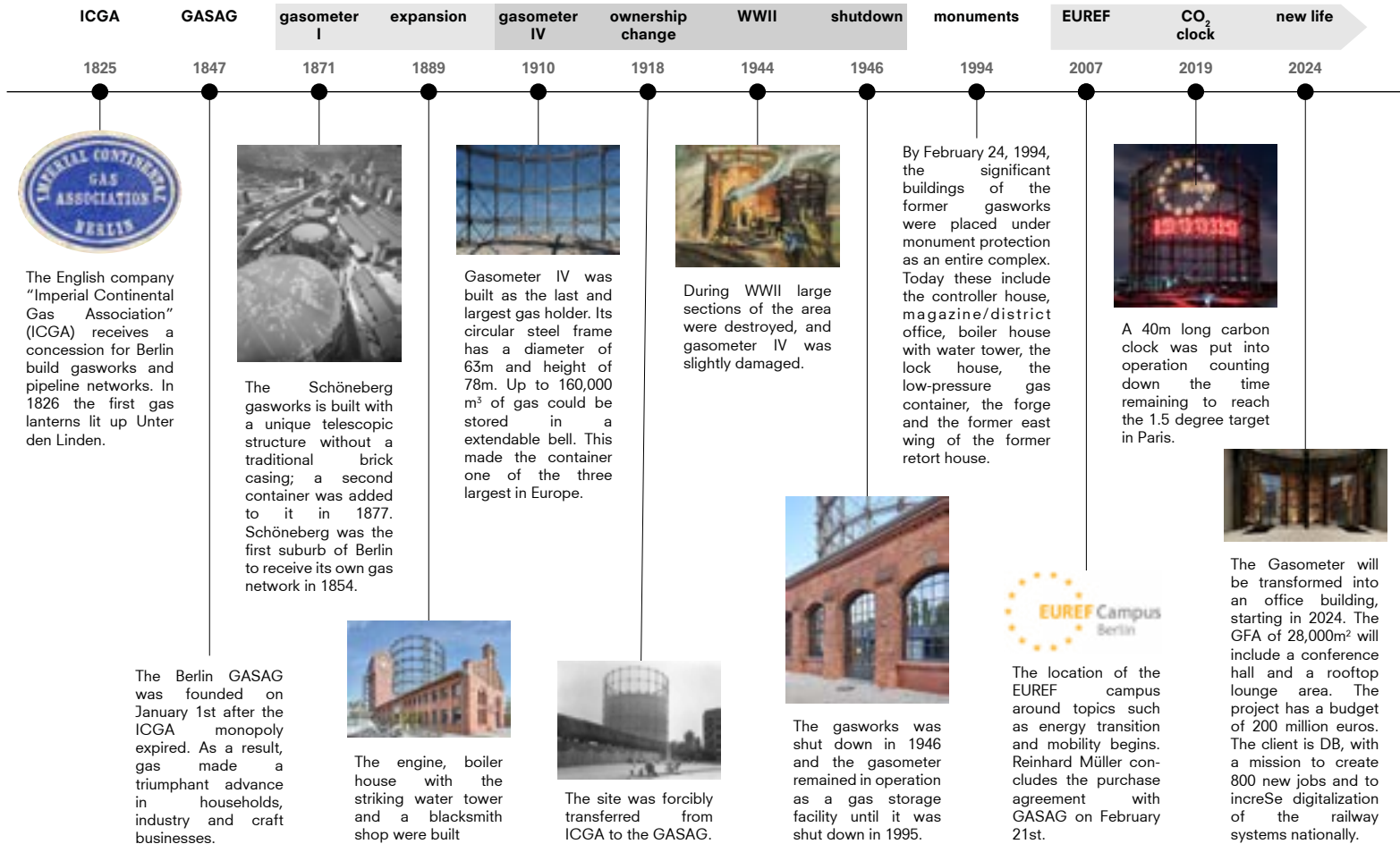

situation

EUREF CAMPUS



situation

EUREF CAMPUS



55,000m² plot



26 buildings



GFA of 28,000m²



150 companies



5,000 employees



300 students



4 MSc programs



2 scientific institutions



symbol of energy transition



Germany's largest electric fuel station



>500 events and >150 international delegations annually



situation

PUBLIC TRANSPORT



10 min walking distance

5 min walking distance

Schöneberg
S Bahn

Südkreuz
S Bahn + DB

situation

ACCESSIBILITY



situation

CAMPUS COMPANIES

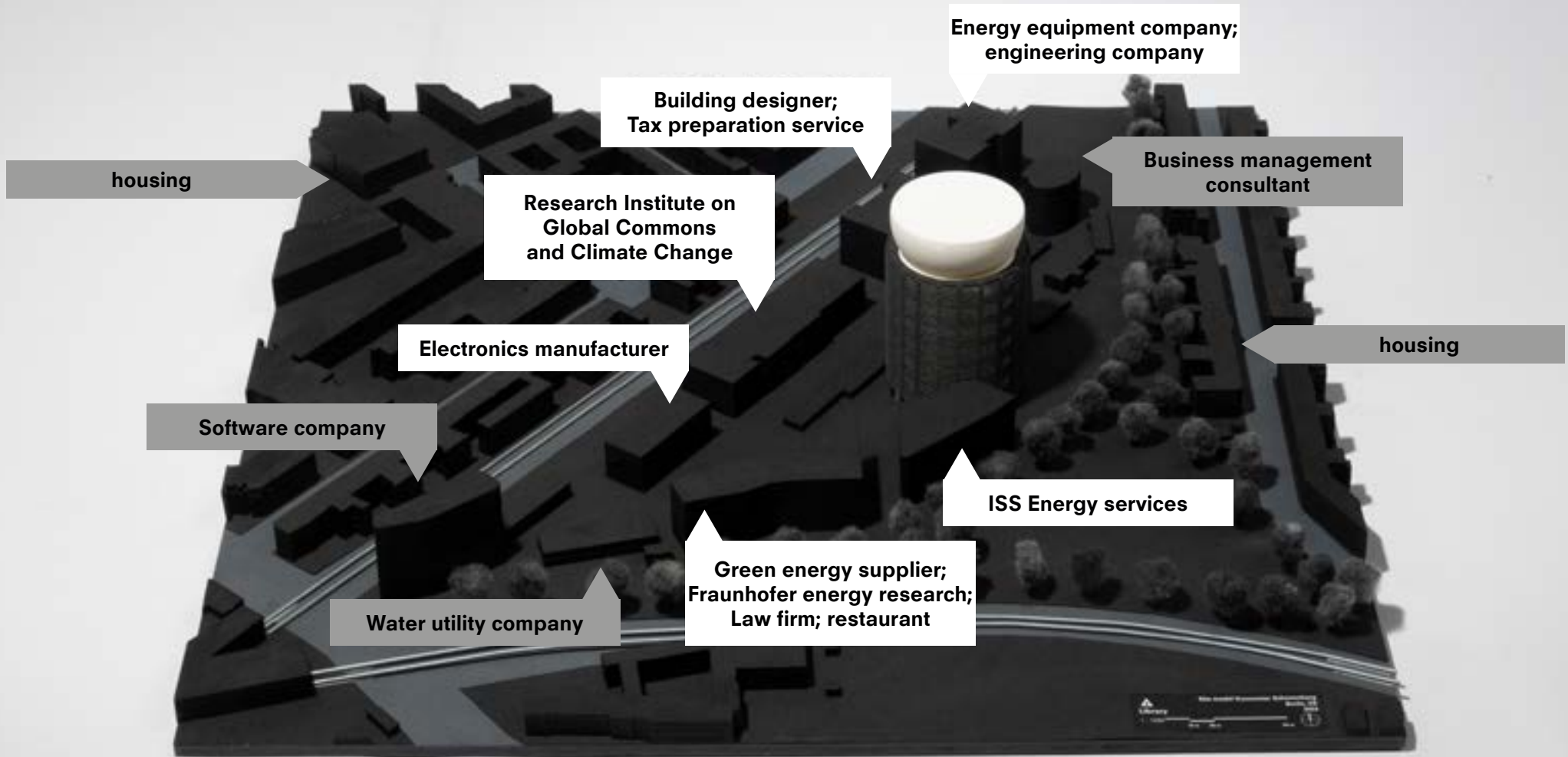

massing

ENTRANCE



SCHÖNEBERG S-BAHN STATION

massing

DIMENSIONS

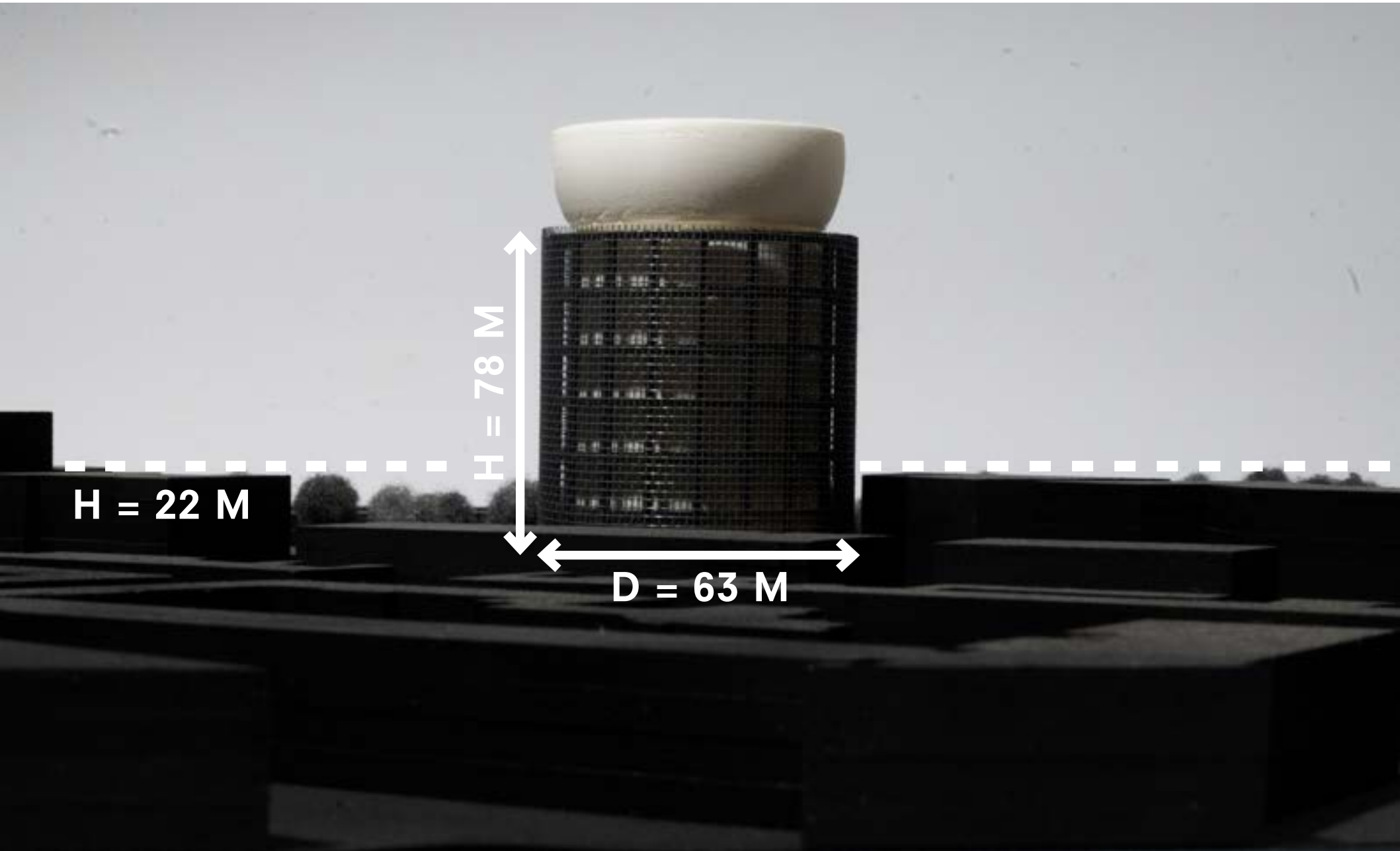

massing

SIGHTLINES

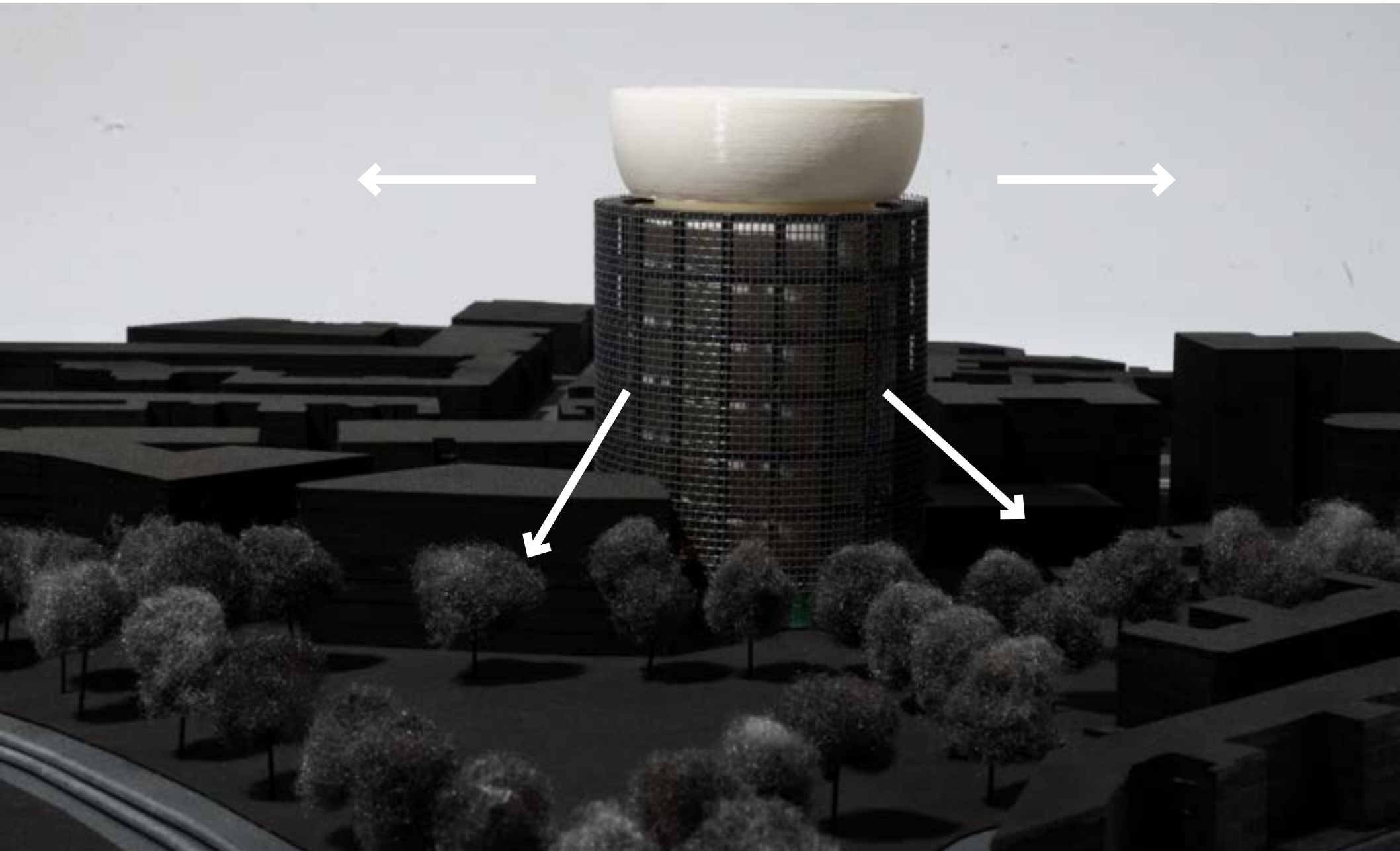

CLIENTS

EUREF CAMPUS BERLIN



FEDERAL INSTITUTE FOR MATERIAL RESEARCH AND TESTING



STATE MUSEUMS IN BERLIN



client

AMBITIONS

PRESERVE

INNOVATE

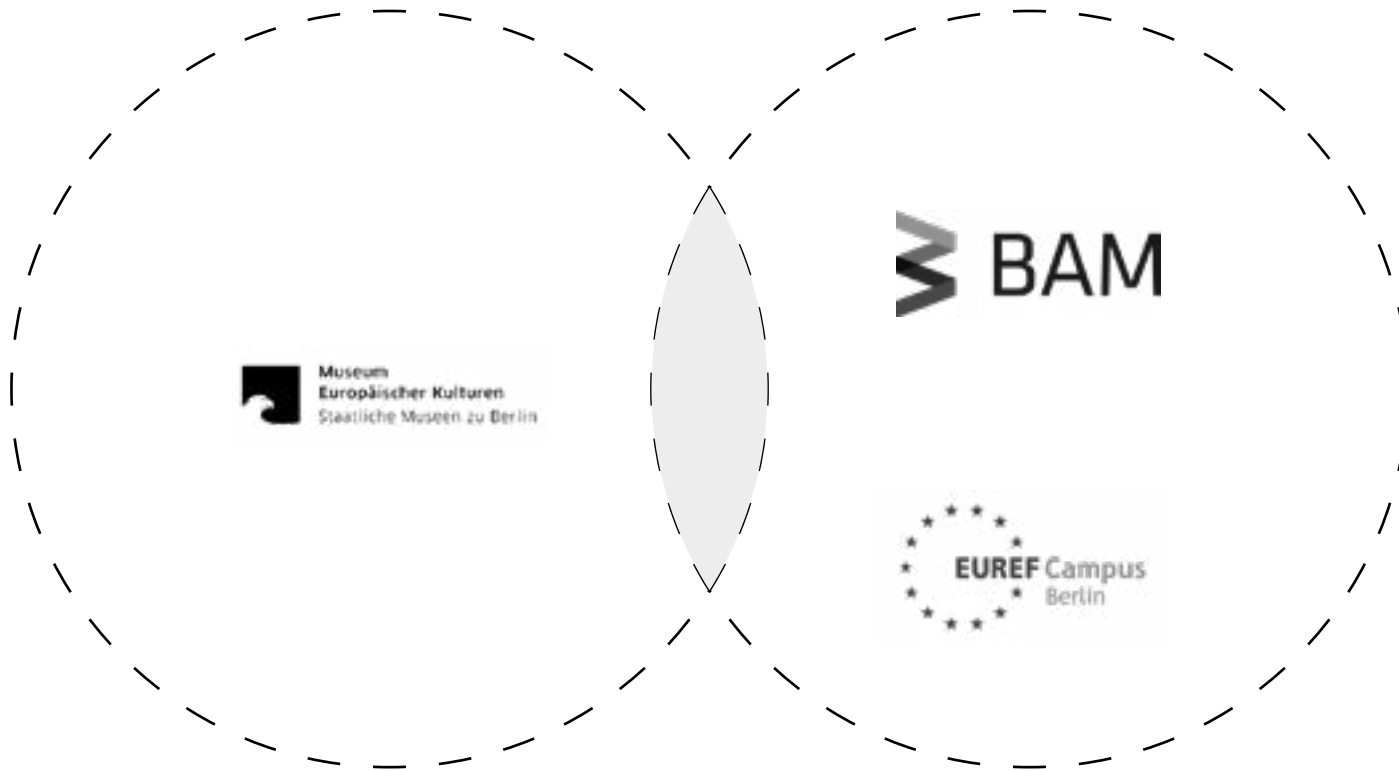

client

FUNCTIONS

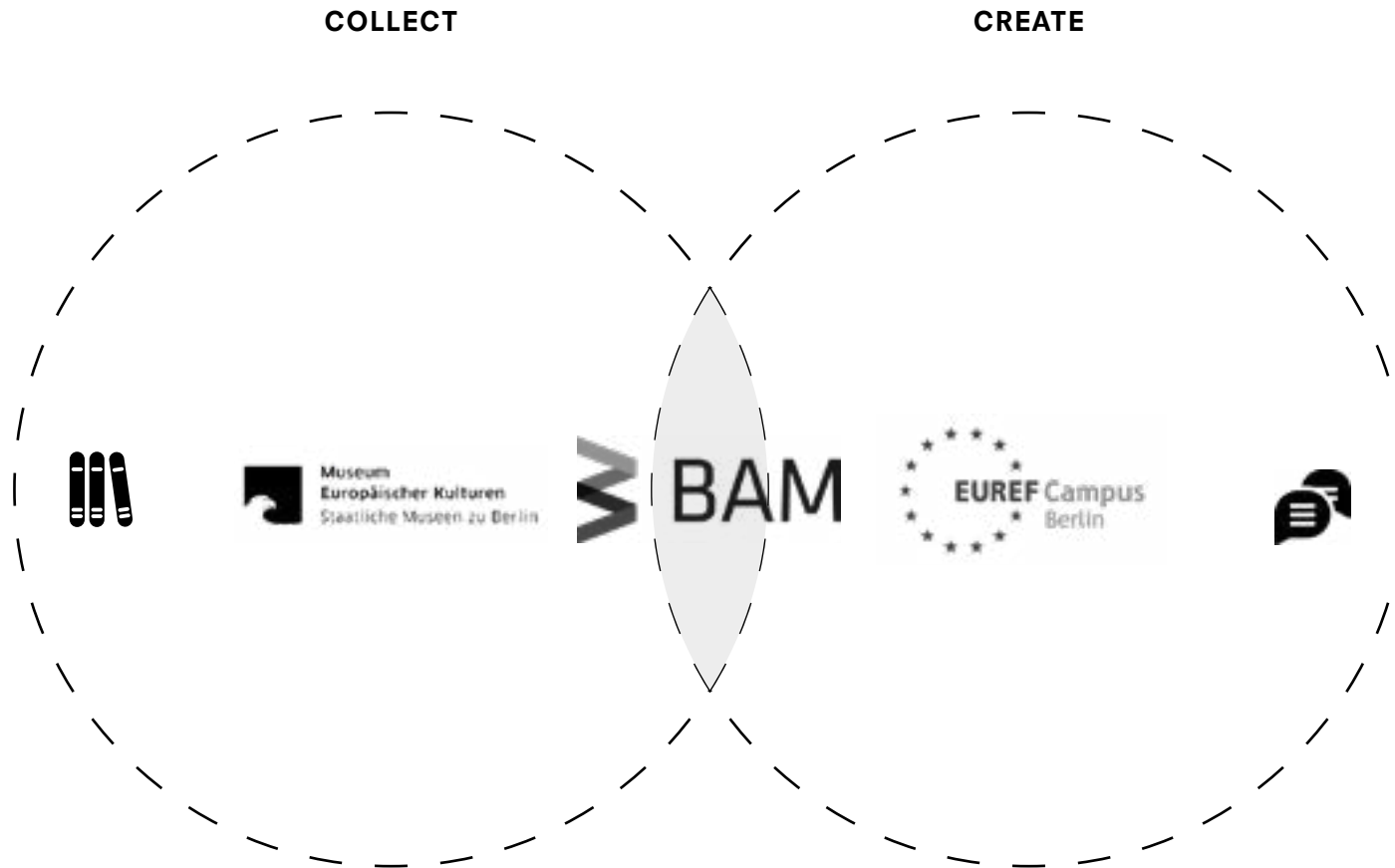

client
USERS

SPECIALISTS

AMATEURS

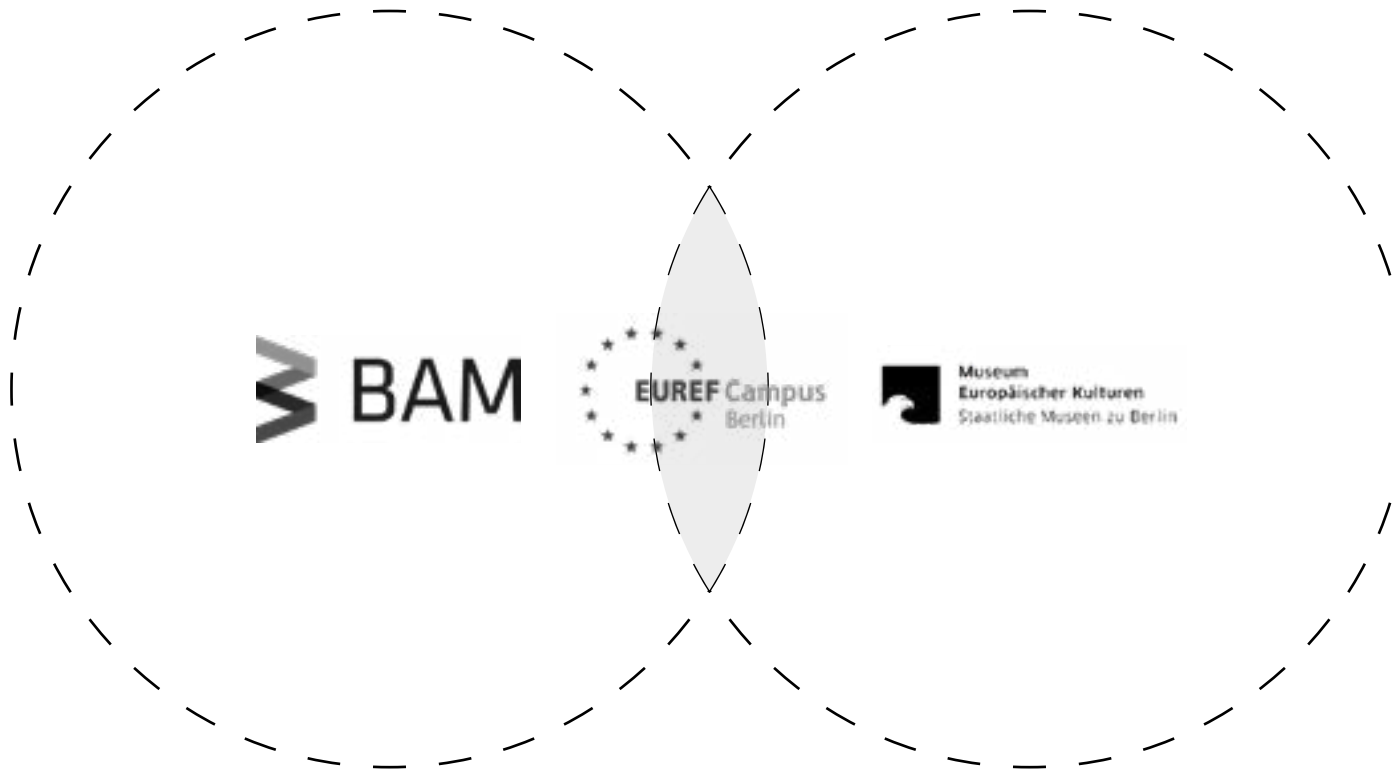

client

FINANCING

PROFIT DRIVEN

GOVERNMENT FUNDED



client

REQUIREMENTS

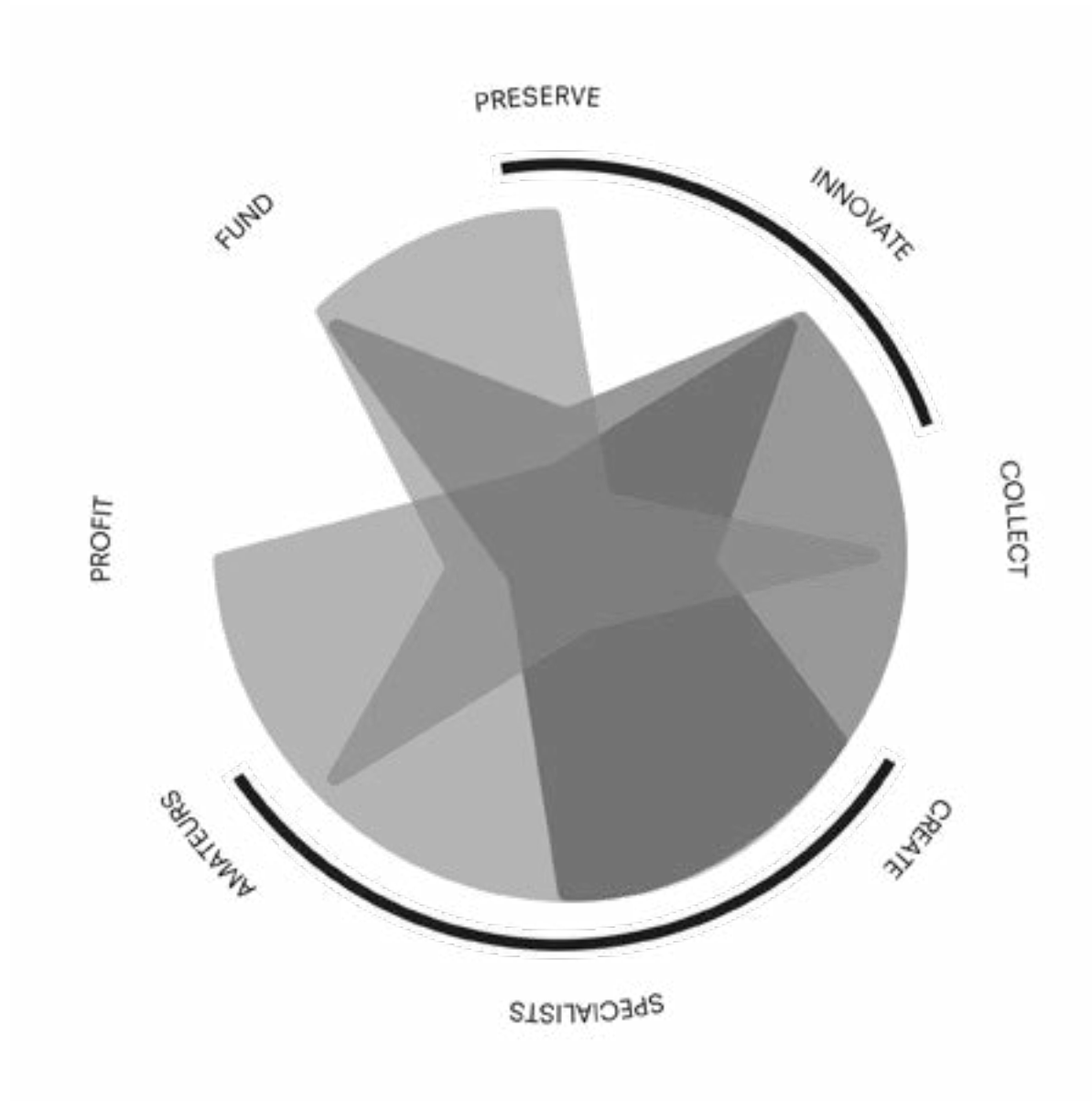

brief
PROGRAM

collection

use

flow

staff

brief
PROGRAM

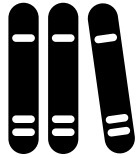

collection

use

flow

staff

brief
PROGRAM

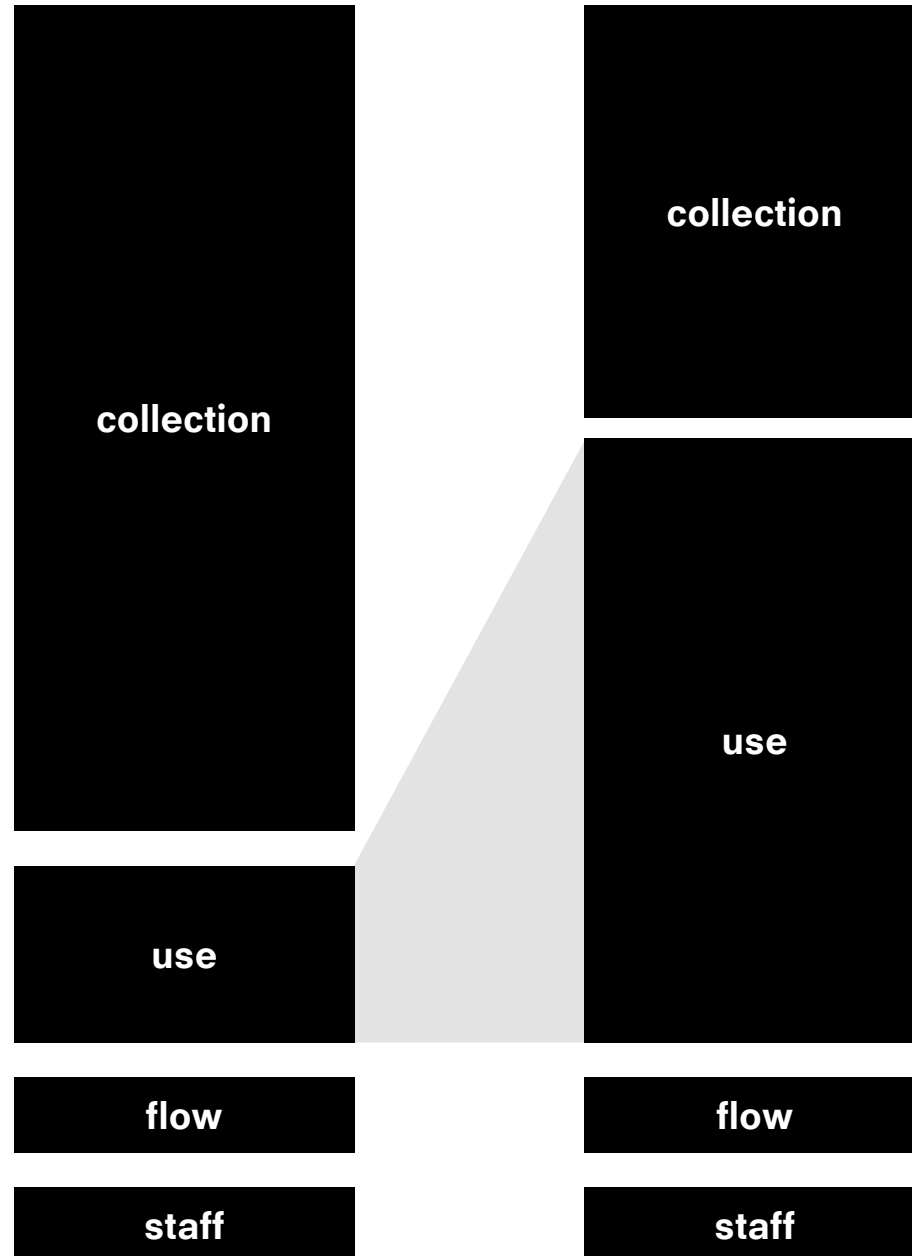
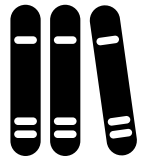

brief
PROGRAM

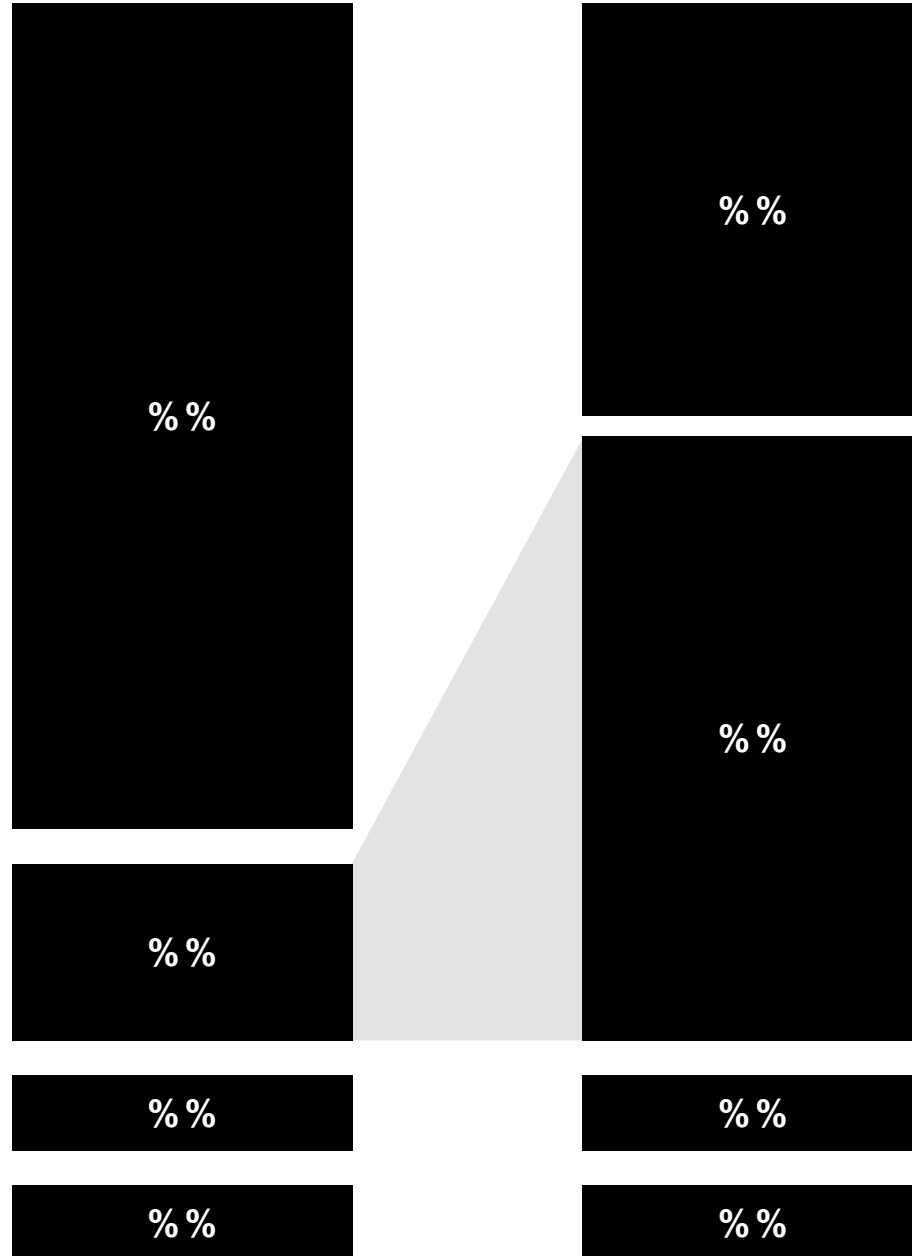
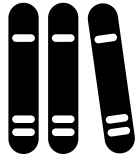

program
BENCHMARKING

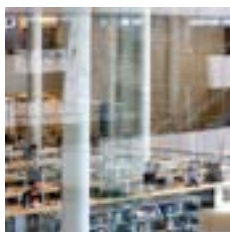

**Architectural
Archive**

**Nievre's
Departmental
Archives**

**Oodi Helsinki
Central Library**

**The Royal
Library**

**Institute for
Sound and
Vision**

**Staatsbibliothek
Unter den
Linden**



program
BENCHMARKING

XS



**Architectural
Archive**

Steven Holl 2014
New York, USA

250 m²

- 3,700 volumes
- 1,200 architectural models

S



**Nievre's
Departmental
Archives**

Patrick Mauger, 2012
Nevers, FR

8 850 m²

- heritage library focused on local and general history

M



**Oodi Helsinki
Central Library**

ALA Architects 2018
Helsingfors, FL

17 250 m²

- 100,000 items

L

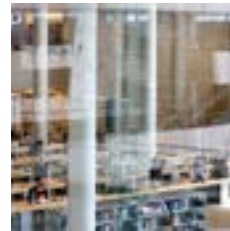

**The Royal
Library**

Schmidt Hammer Lassen
Architects, 1999
Copenhagen, DK

21 000 m²

- 200,000 books
- 600-seat hall

XL



**Institute for
Sound and
Vision**

Neutelings Riedijk
Architects, 2006
Hilversum, NL

45 000 m²

- 800,000 hours of audiovisual productions
- photographs, objects, costumes, books, scripts, logbooks, memorabilia

XXL







**Staatsbibliothek
Unter den
Linden**

Ernst von Ihne, 1661
BAL, 2019
Berlin, DE

107 000 m²

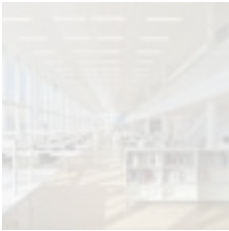
- 305,486 visitors in 2020
- 12 million inventory of books, newspapers and periodicals

program
BENCHMARKING

XS	S	M	L	XL	XXL
					
Architectural Archive	Nievre's Departmental Archives	Oodi Helsinki Central Library	The Royal Library	Institute for Sound and Vision	Staatsbibliothek Unter den Linden
Steven Holl 2014 New York, USA	Patrick Mauger, 2012 Nevers, FR	ALA Architects 2018 Helsingfors, FL	Schmidt Hammer Lassen Architects, 1999 Copenhagen, DK	Neutelings Riedijk Architects, 2006 Hilversum, NL	Ernst von Ihne, 1661 BAL, 2019 Berlin, DE
250 m²	8 850 m²	17 250 m²	21 000 m²	45 000 m²	107 000 m²
<ul style="list-style-type: none"> • 3,700 volumes • 1,200 architectural models 	<ul style="list-style-type: none"> • heritage library focused on local and general history 	<ul style="list-style-type: none"> • 100,000 items 	<ul style="list-style-type: none"> • 200,000 books • 600-seat hall 	<ul style="list-style-type: none"> • 800,000 hours of audiovisual productions • photographs, objects, costumes, books, scripts, logbooks, memorabilia 	<ul style="list-style-type: none"> • 305,486 visitors in 2020 • 12 million inventory of books, newspapers and periodicals

program
BENCHMARKING

M



**Oodi Helsinki
Central Library**



L



**The Royal
Library**



XL



**Institute for
Sound and
Vision**

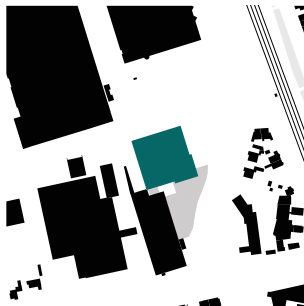

XXL



**Staatsbibliothek
Unter den
Linden**



program
BENCHMARKING



**Oodi Helsinki
Central Library**



**The Royal
Library**

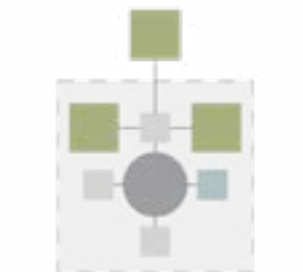

**Institute for
Sound and
Vision**

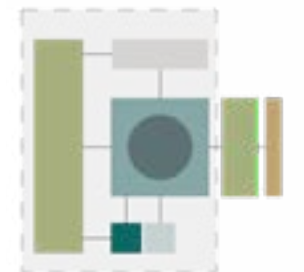
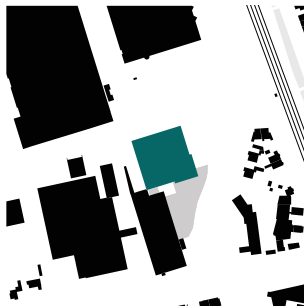

**Staatsbibliothek
Unter den
Linden**



program
DISTRIBUTION

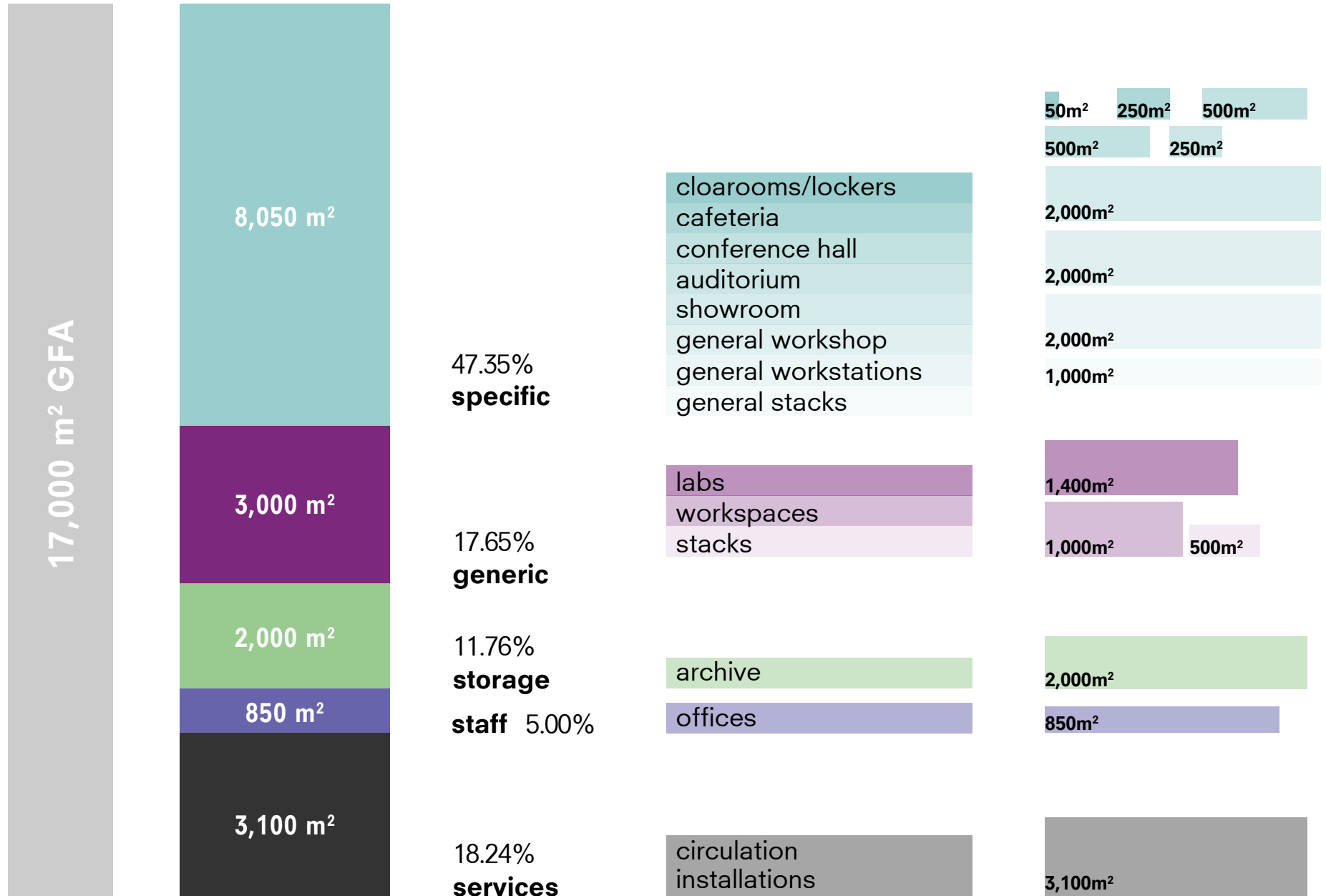

- 01 INTRODUCTION
- 02 LIBRARY
- 03 DESIGN BRIEF
- 04 DESIGN CONCEPT**
- 05 DESIGN IMPLEMENTATION
- 06 CONCLUSION

design concept

DISTRIBUTION

TYPE

CONCRETES

CERAMICS/CLAY

GLASS

METALS

NATURALS

animal-based

plant-based

wood-based

PLASTICS

RECYCLED/REUSED

design concept

DISTRIBUTION

TYPE

CONCRETES

CERAMICS/CLAY

GLASS

METALS

NATURALS

PLASTICS

RECYCLED/REUSED

animal-based
plant-based
wood-based

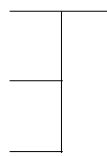

LABS

design concept

DISTRIBUTION

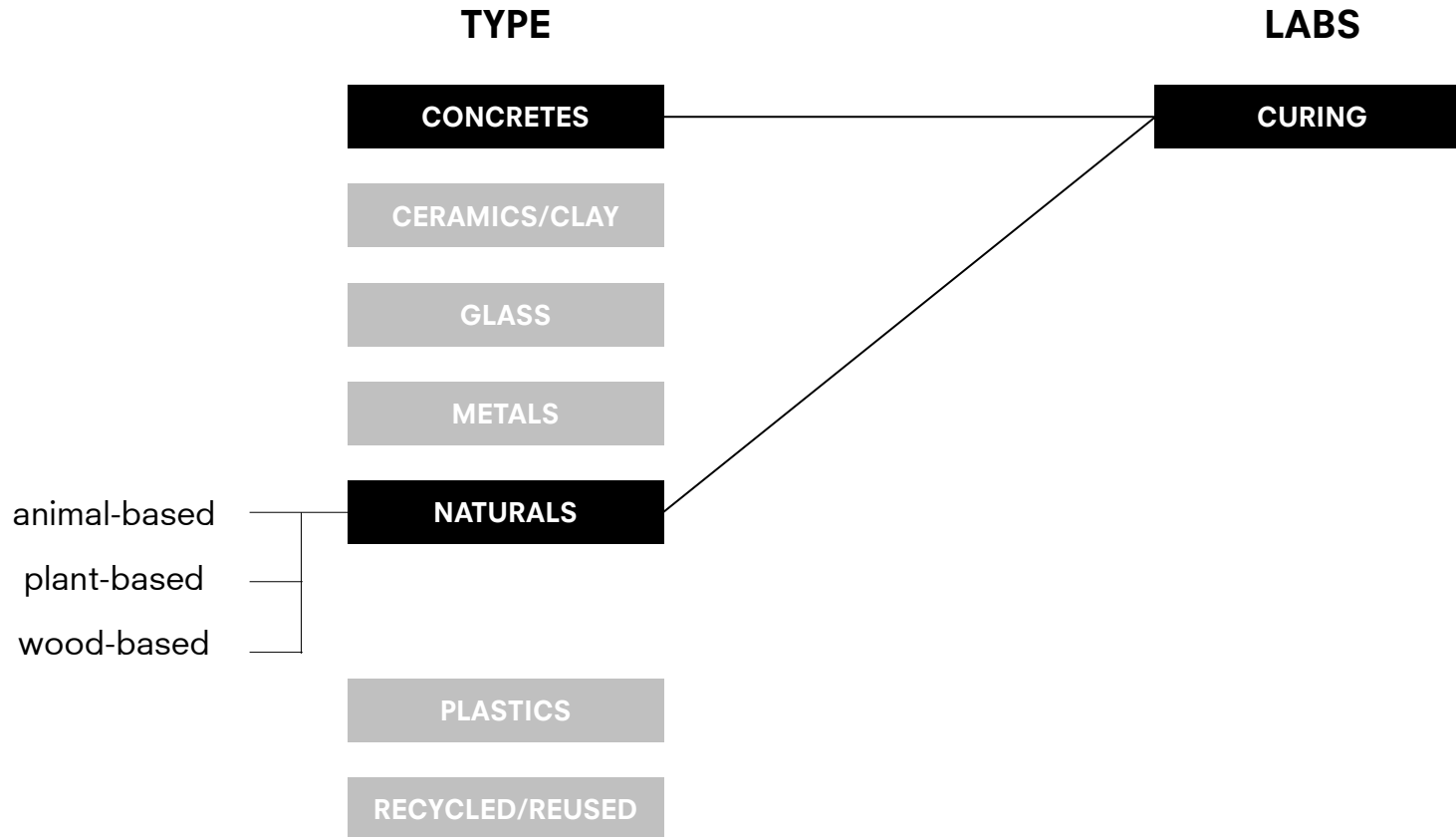

design concept

DISTRIBUTION

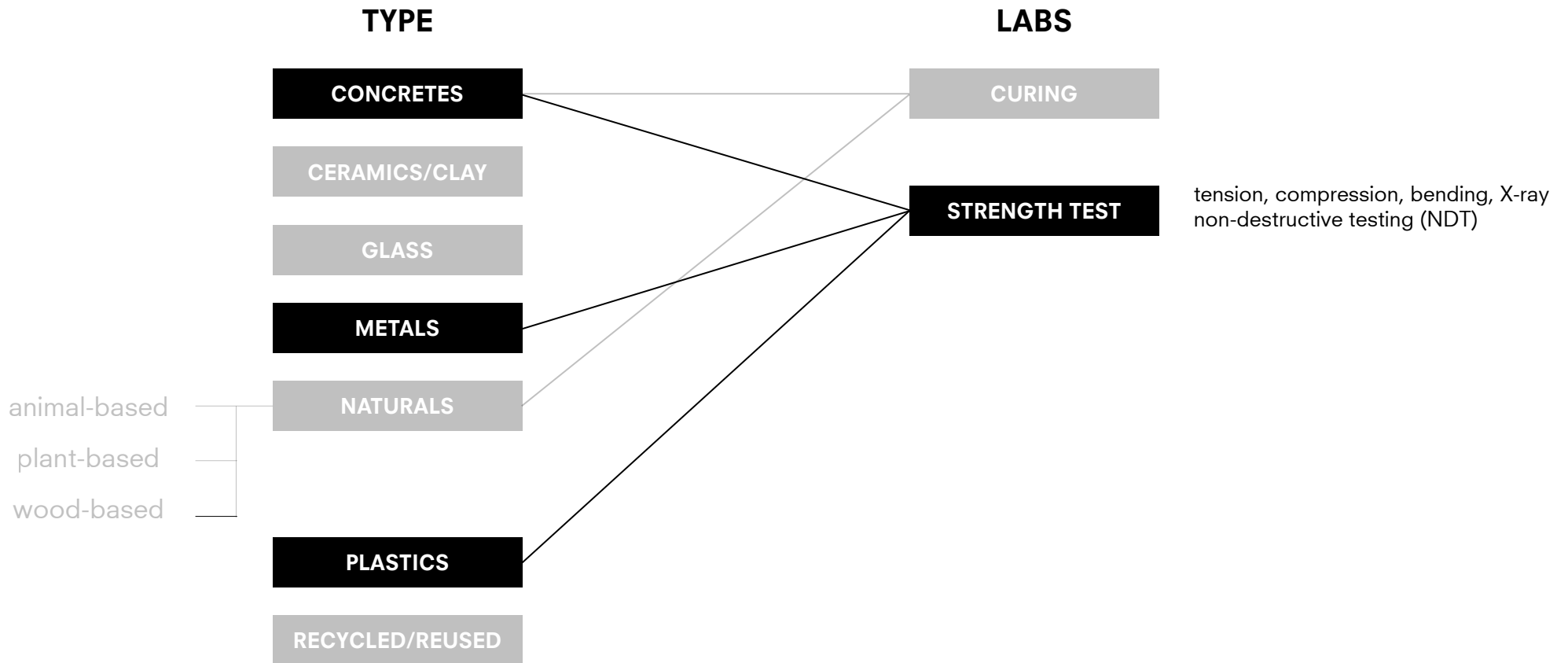

design concept

DISTRIBUTION

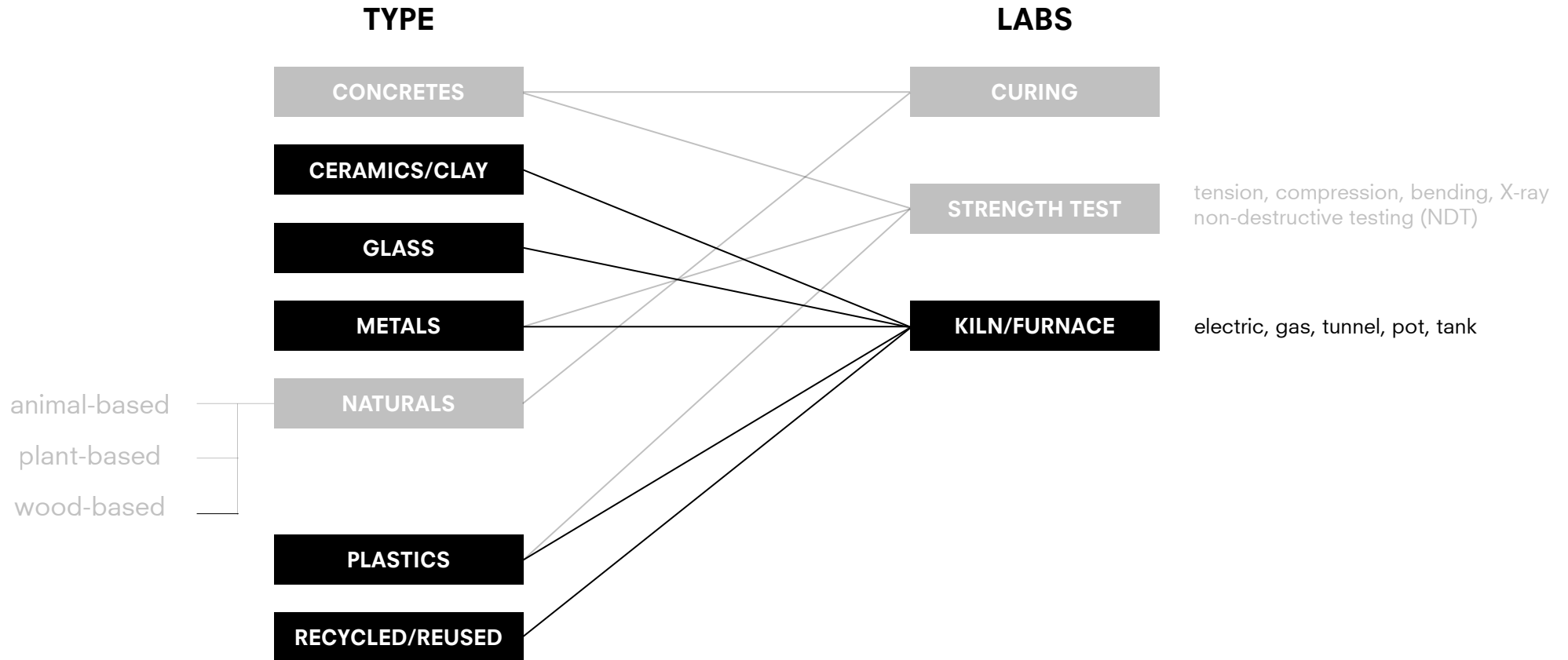

design concept
DISTRIBUTION

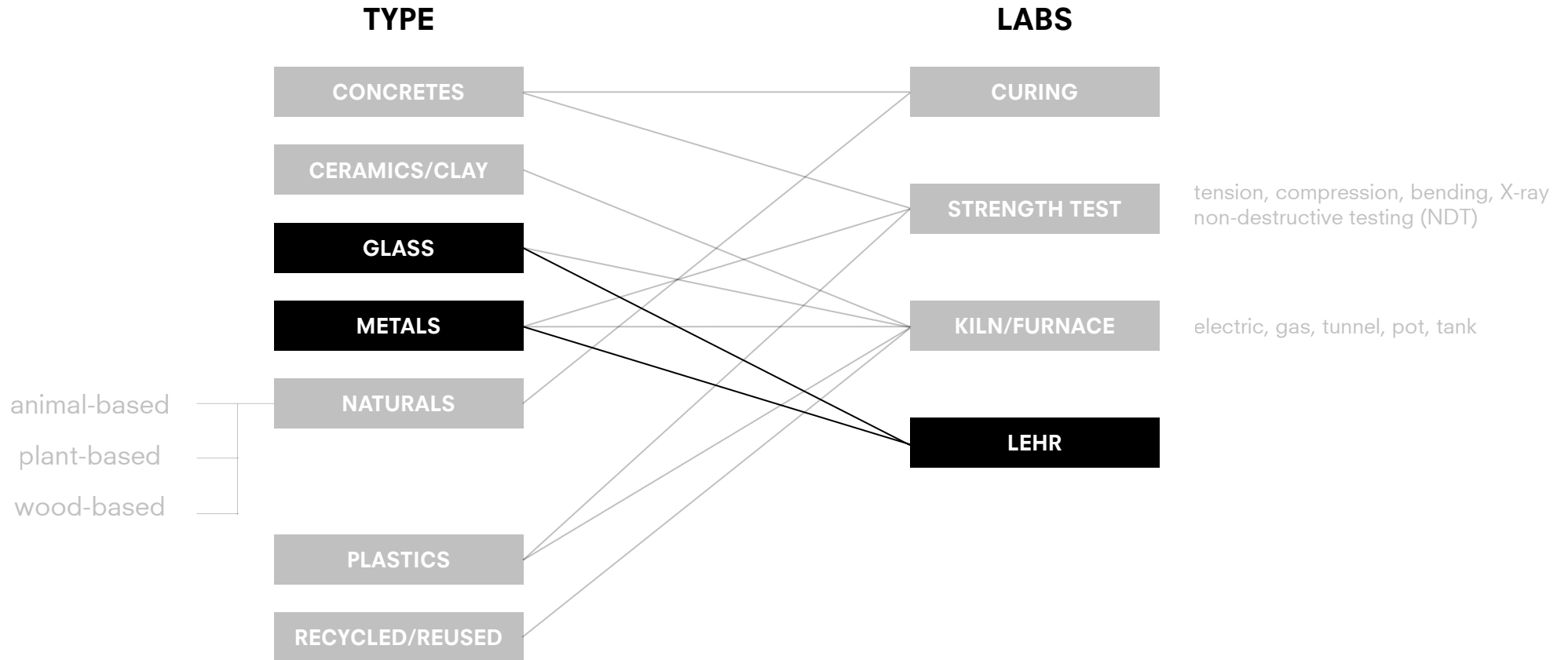

design concept

DISTRIBUTION

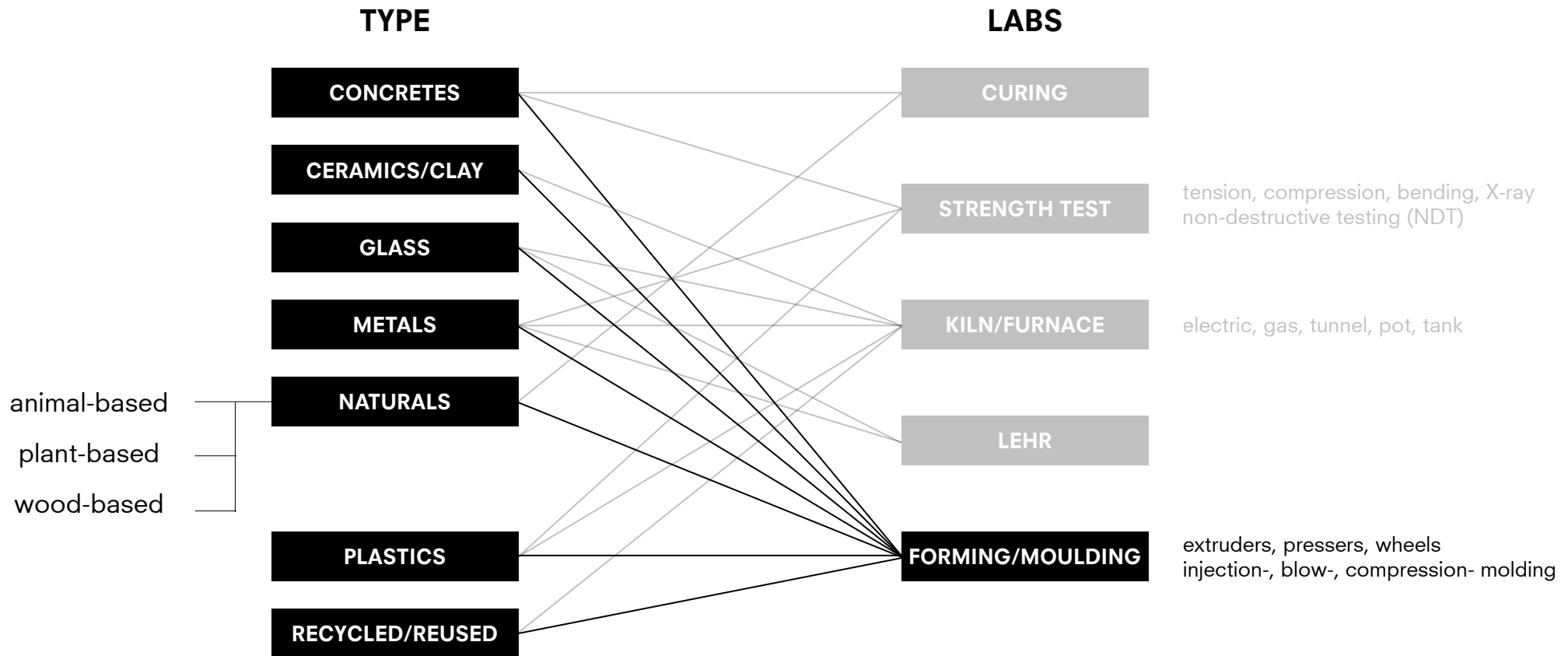

design concept

DISTRIBUTION

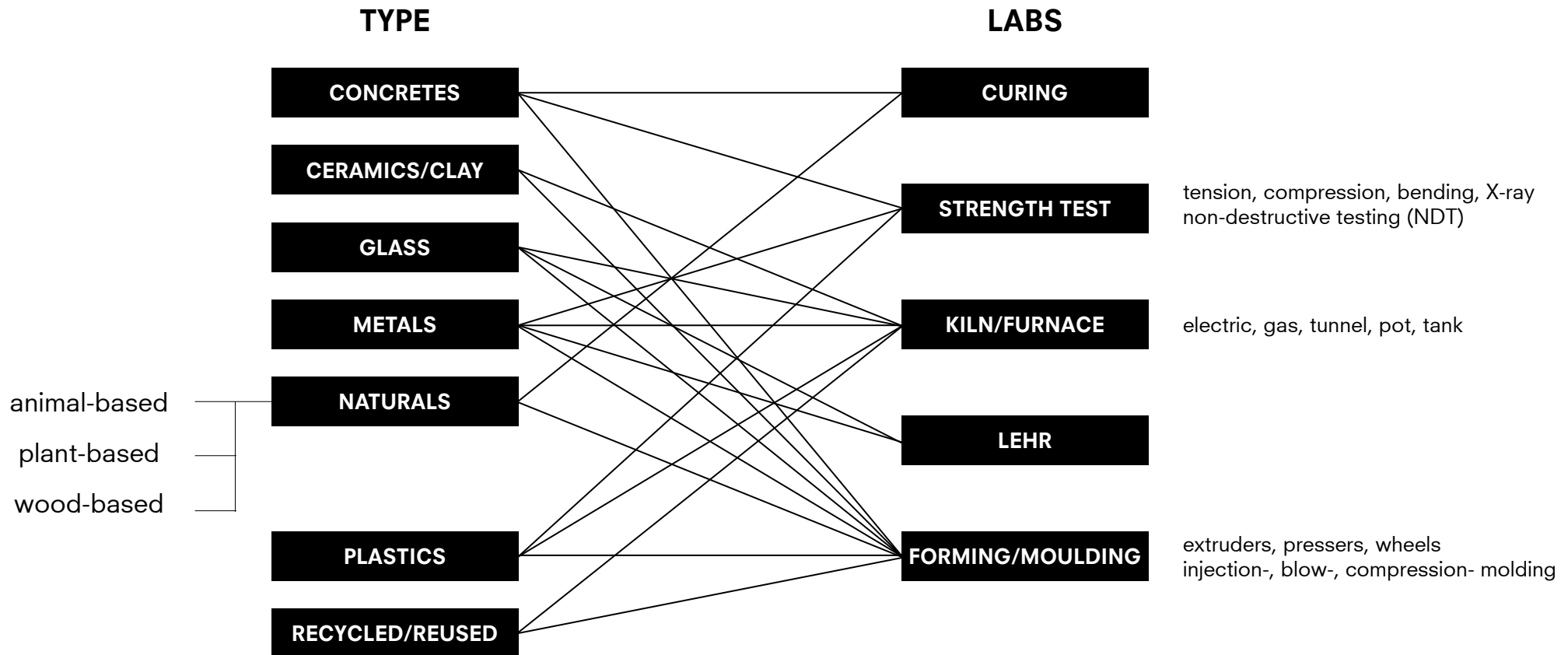

design concept
DISTRIBUTION

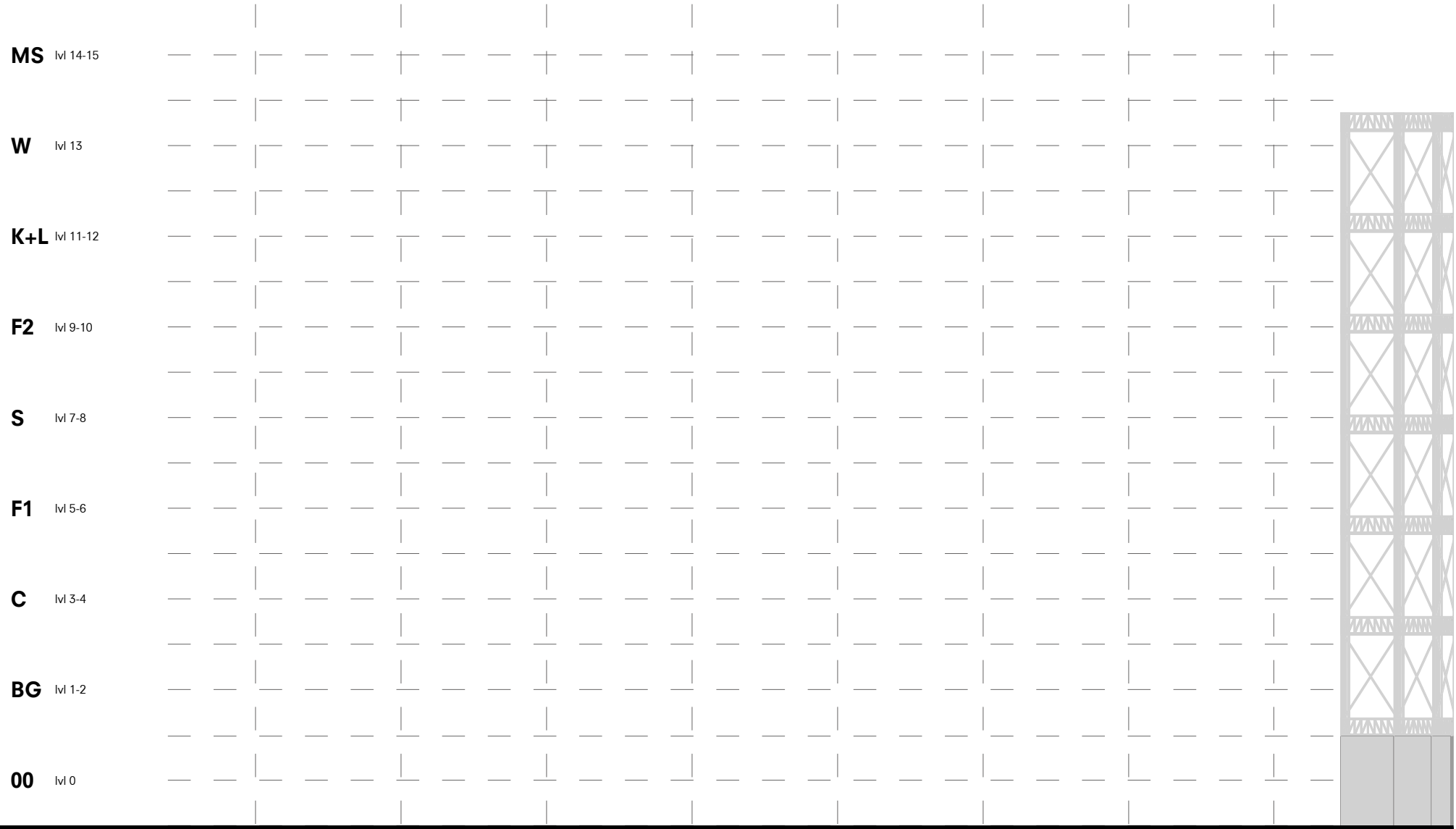

no access



public access



academic access



staff access



restricted access

design concept
DISTRIBUTION

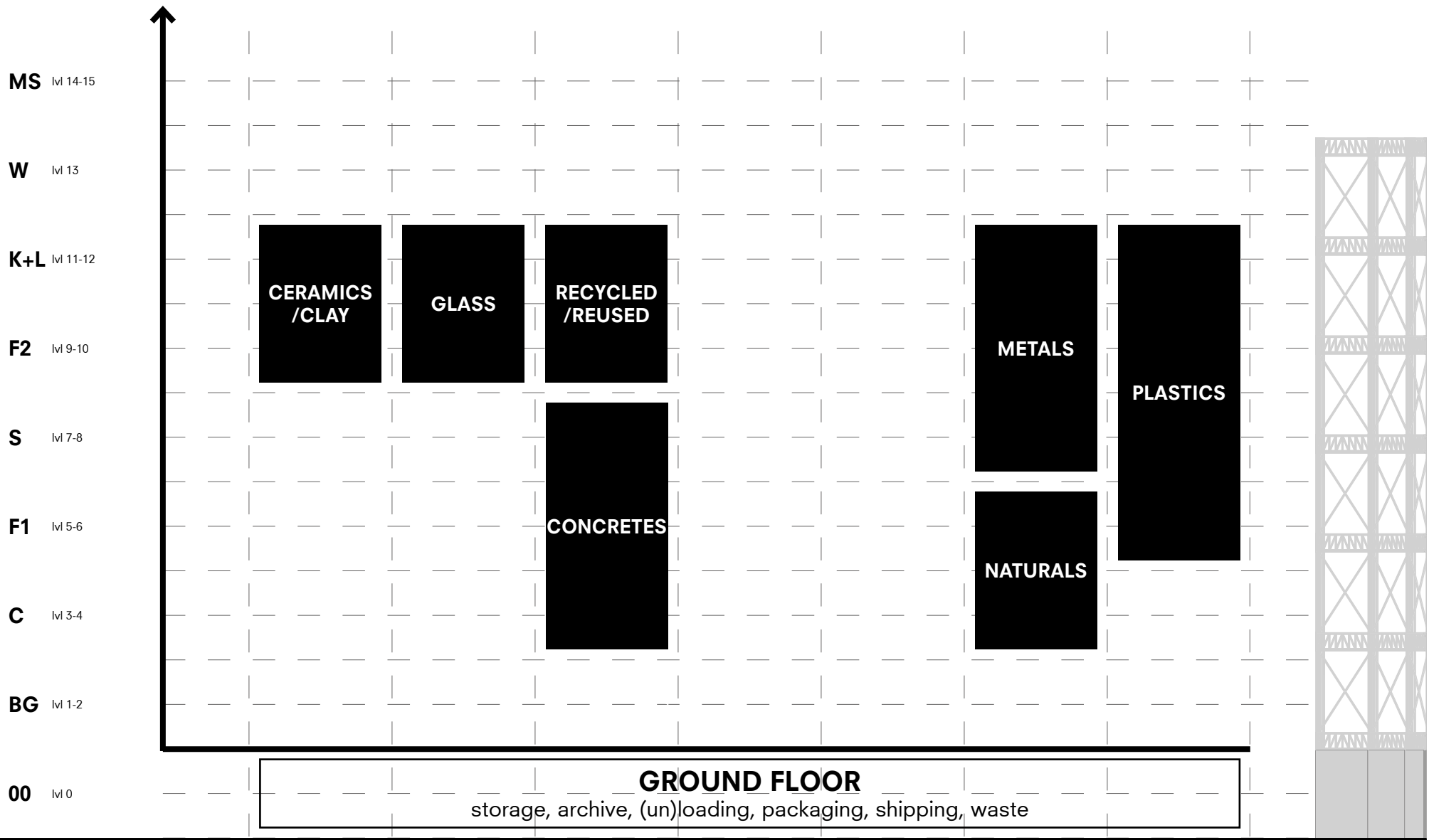

no access
 public access
 academic access
 staff access
 restricted access

design concept
DISTRIBUTION

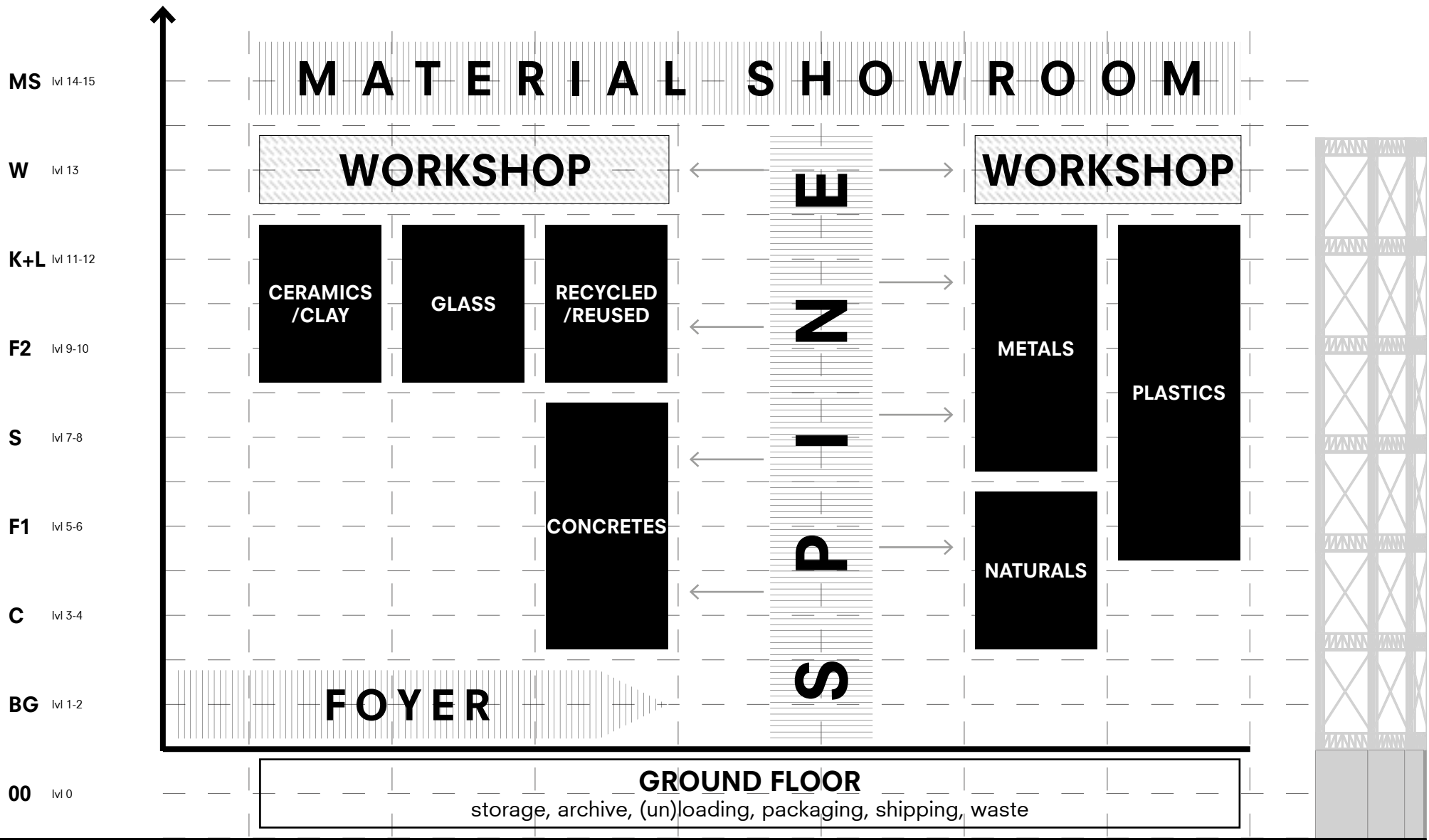

no access
 public access
 academic access
 staff access
 restricted access

design concept
DISTRIBUTION

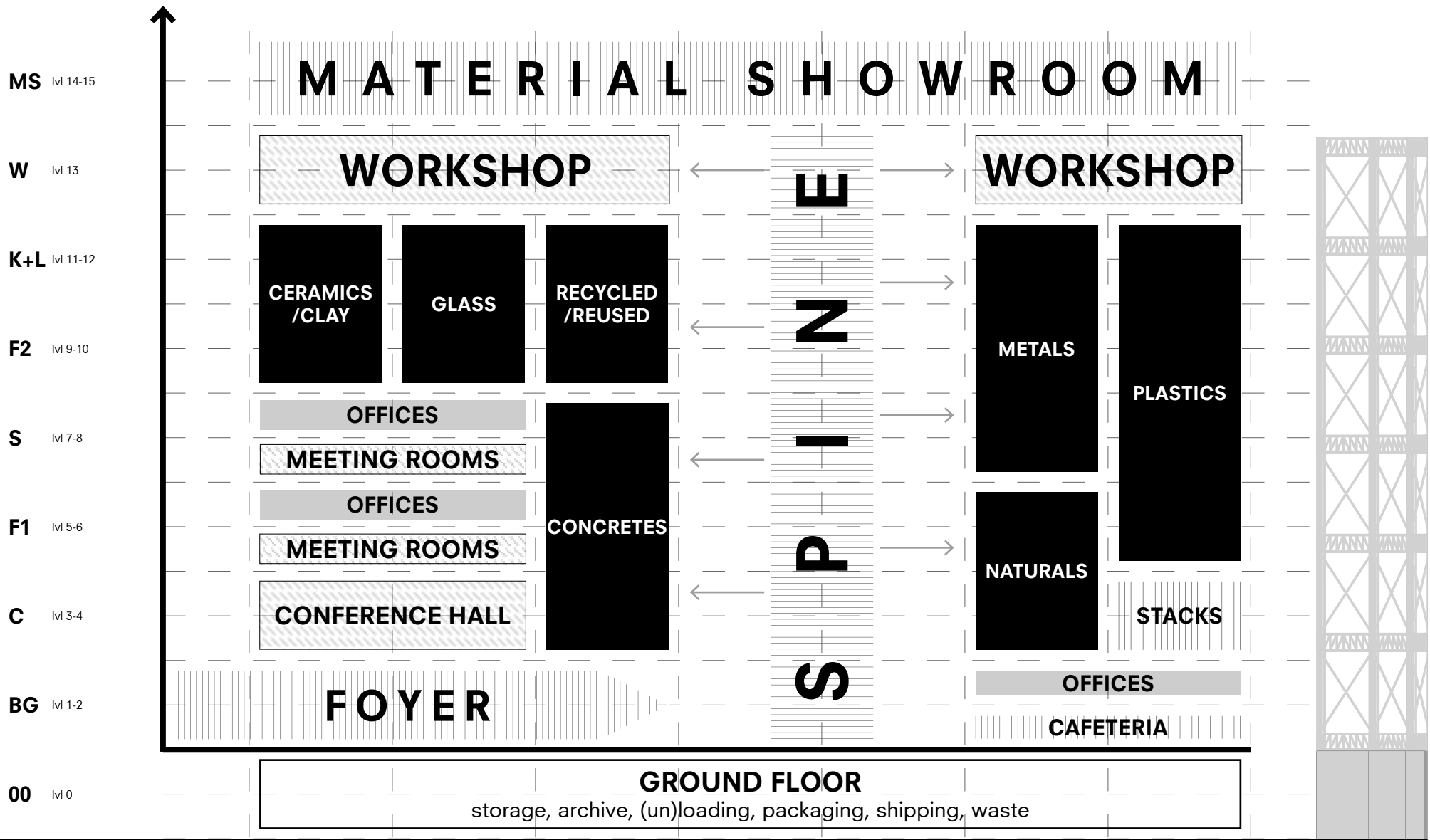

no access
 public access
 academic access
 staff access
 restricted access

design concept

MAIN COMPONENTS

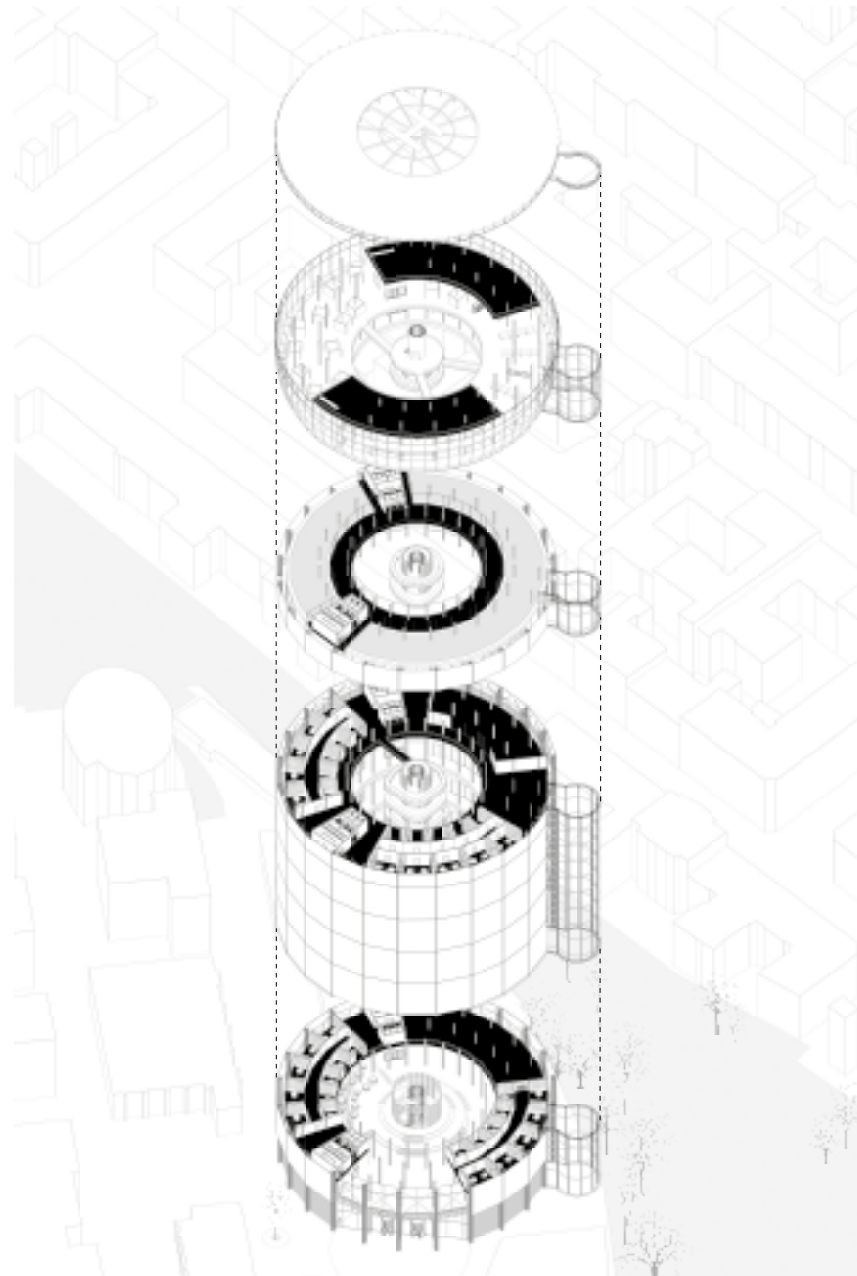

design concept
THE PLINTH

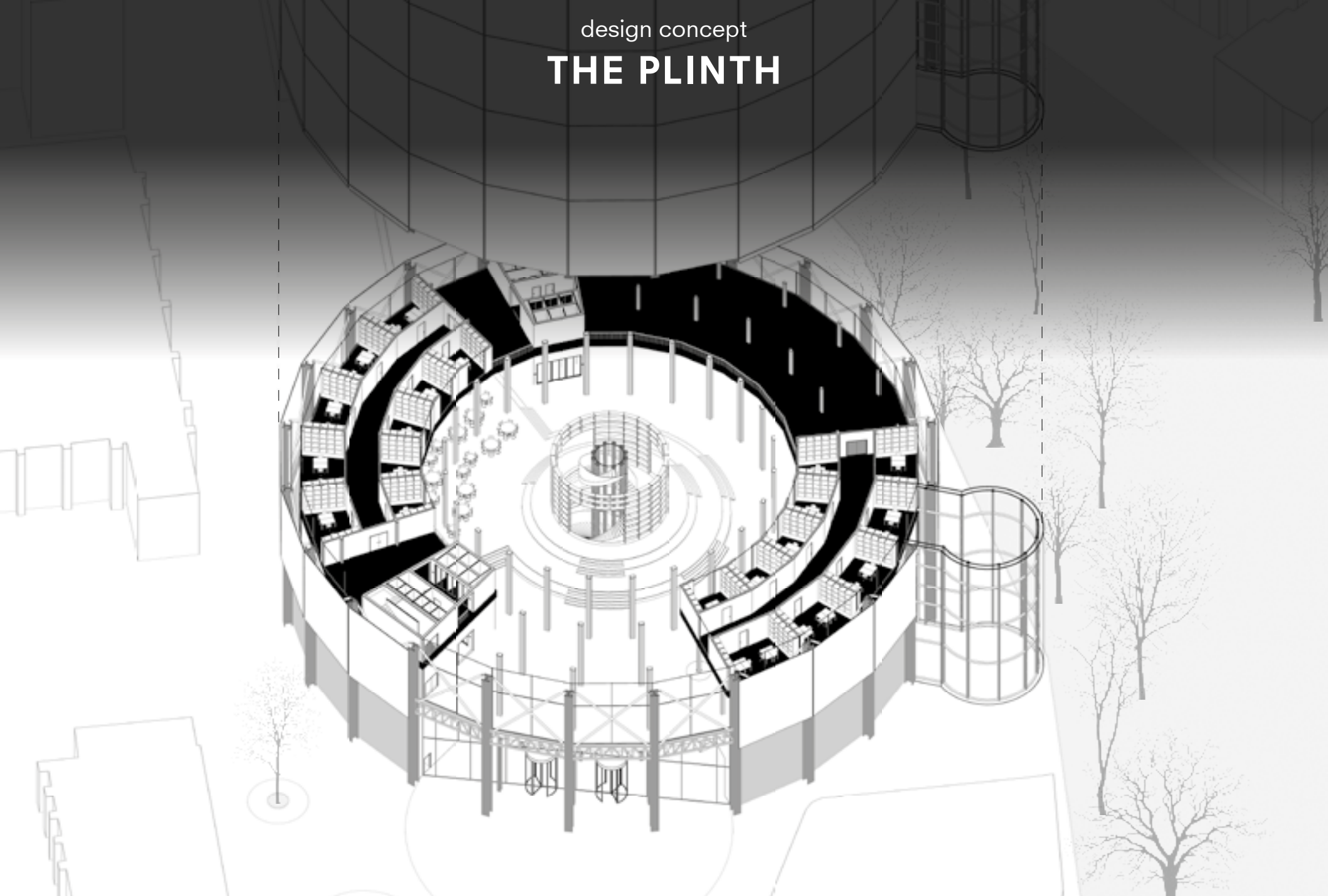

design concept
THE SPINE

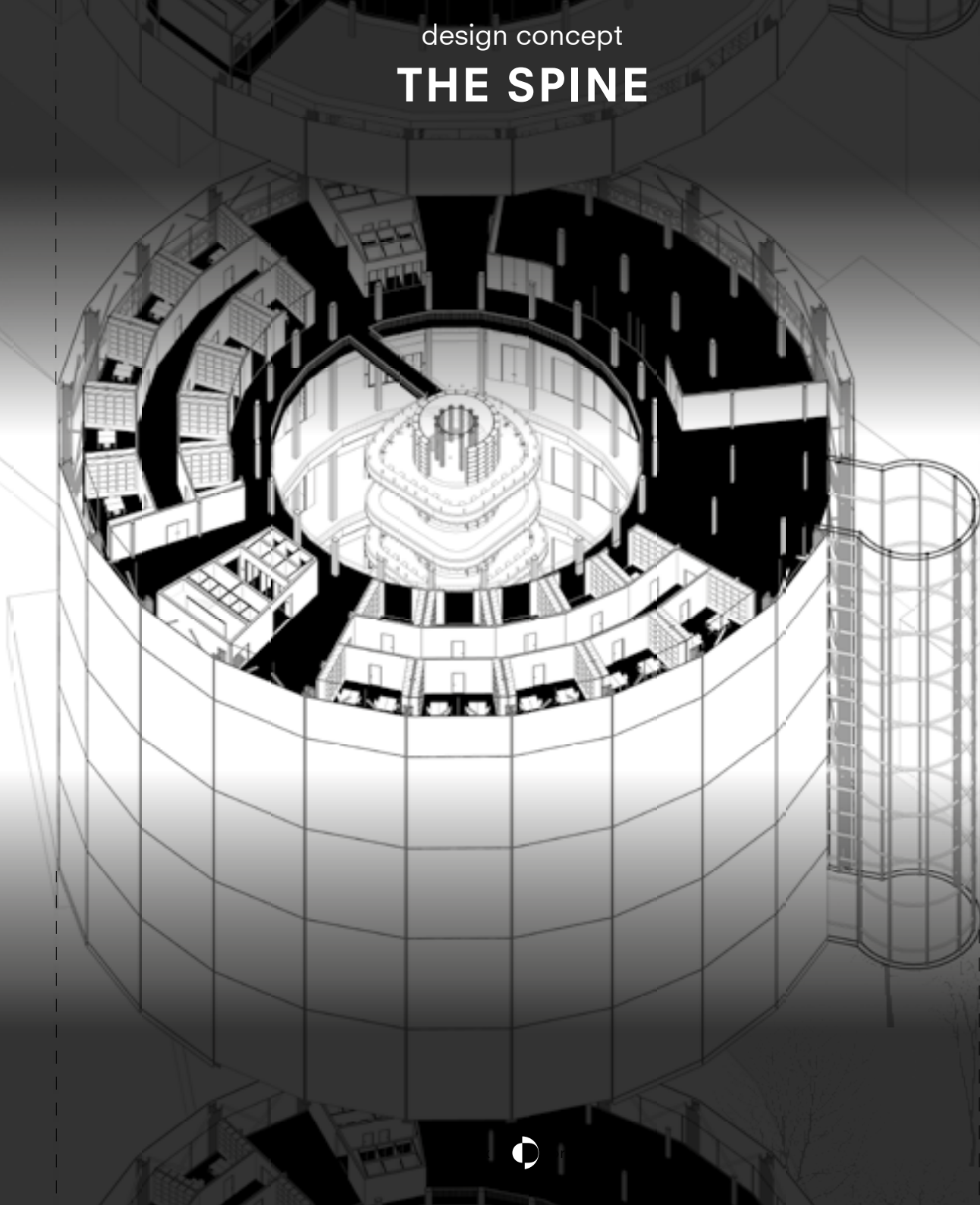

design concept

THE CROWN

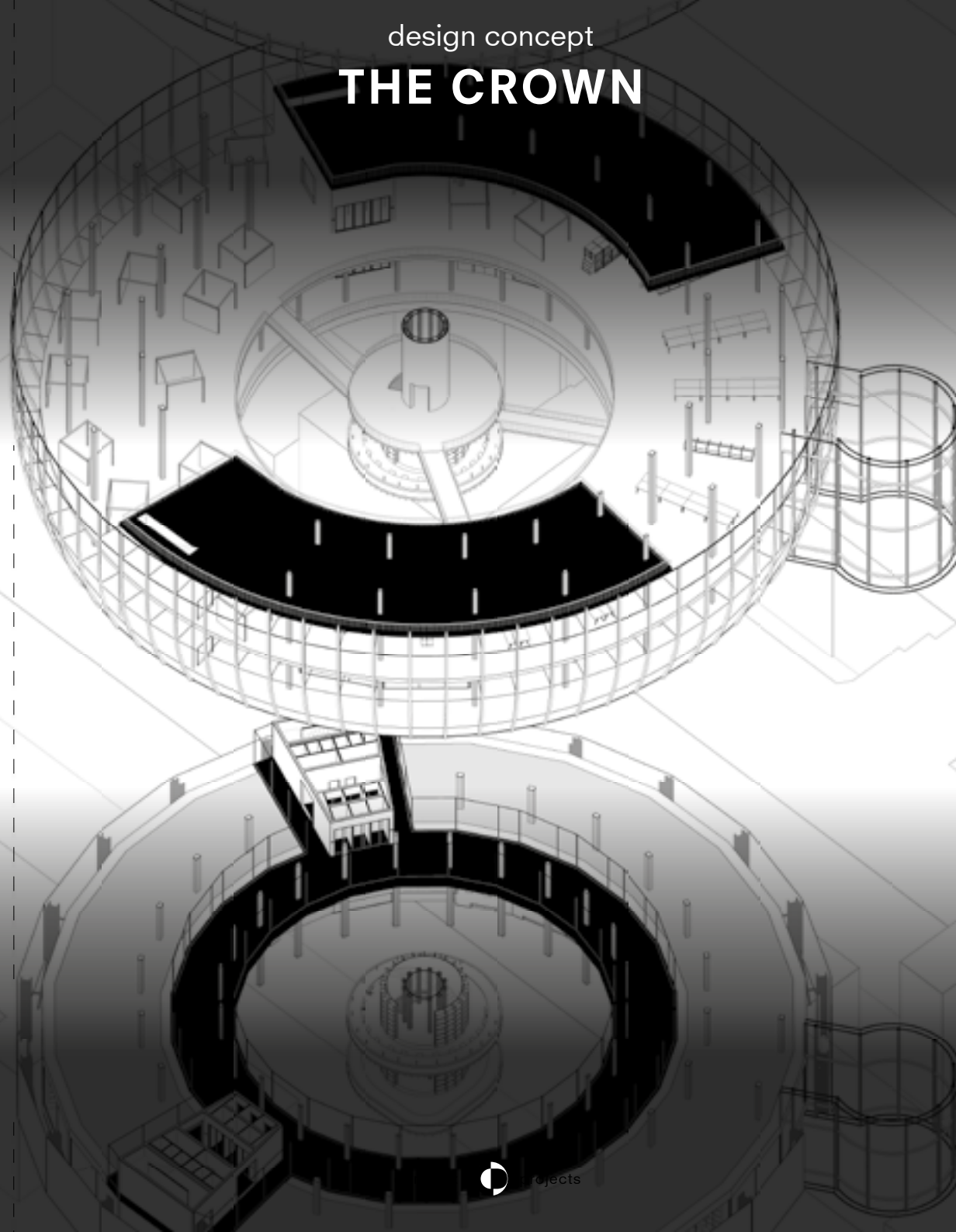

design concept

MAIN COMPONENTS

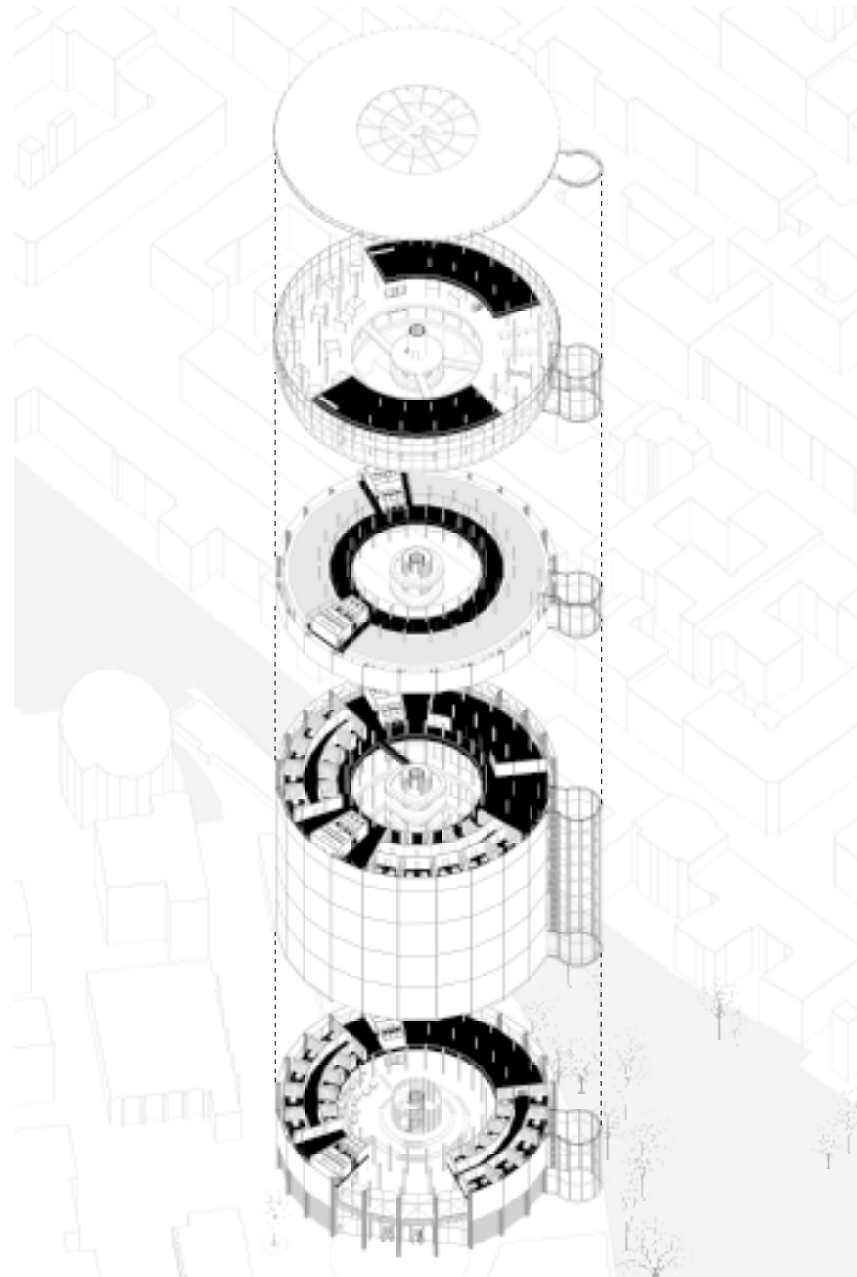

- 01 INTRODUCTION
- 02 LIBRARY
- 03 DESIGN BRIEF
- 04 DESIGN CONCEPT
- 05 DESIGN IMPLEMENTATION**
- 06 CONCLUSION

urban implementation

WALK TOWARDS EUREF CAMPUS



urban implementation

ENTER FROM TORGAUER STRASSE



urban implementation

THE CAMPUS

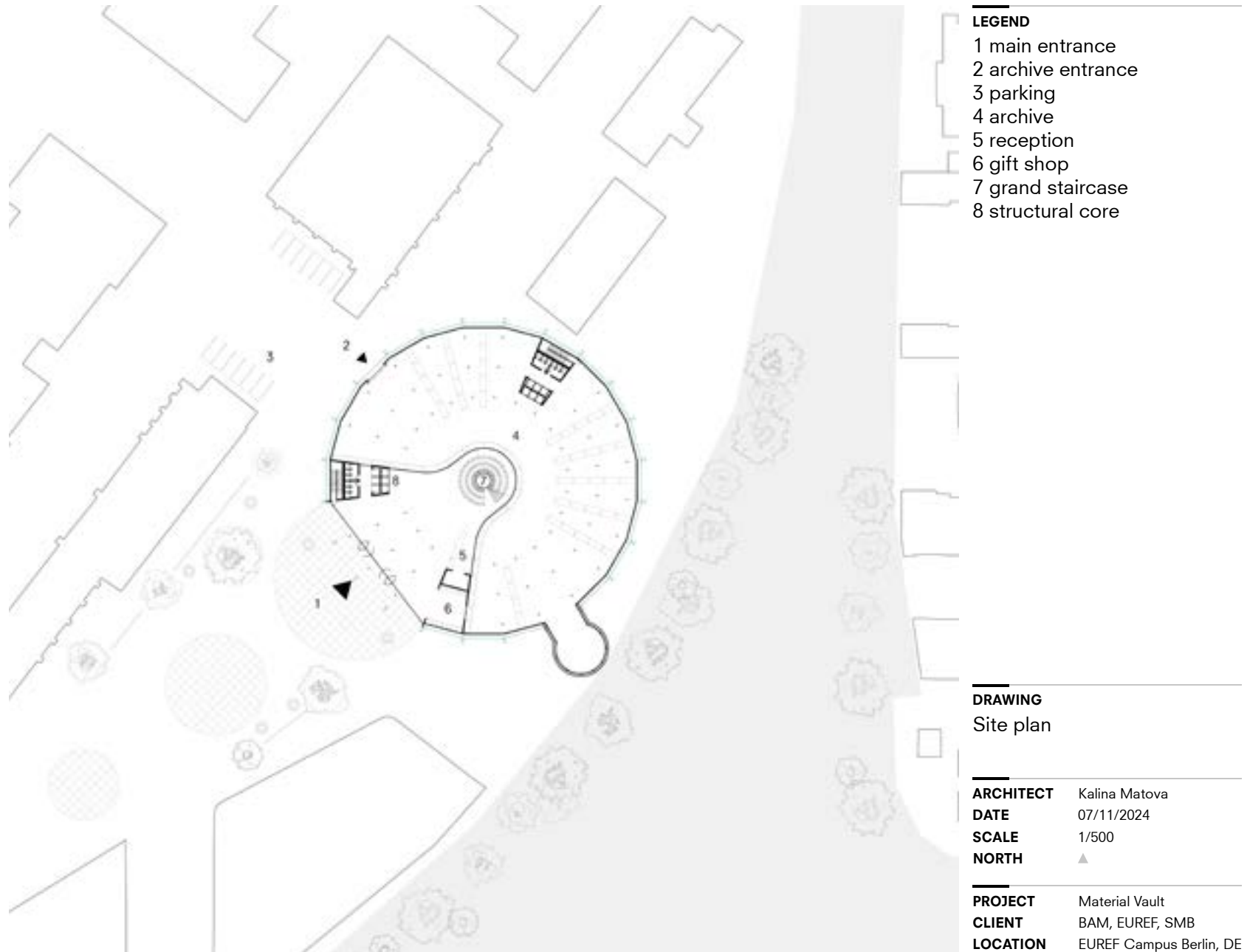

urban implementation

THE CAMPUS



urban implementation

THE CAMPUS



the plinth

ENTRANCE



intermezzo

FACADE STRUCTURE

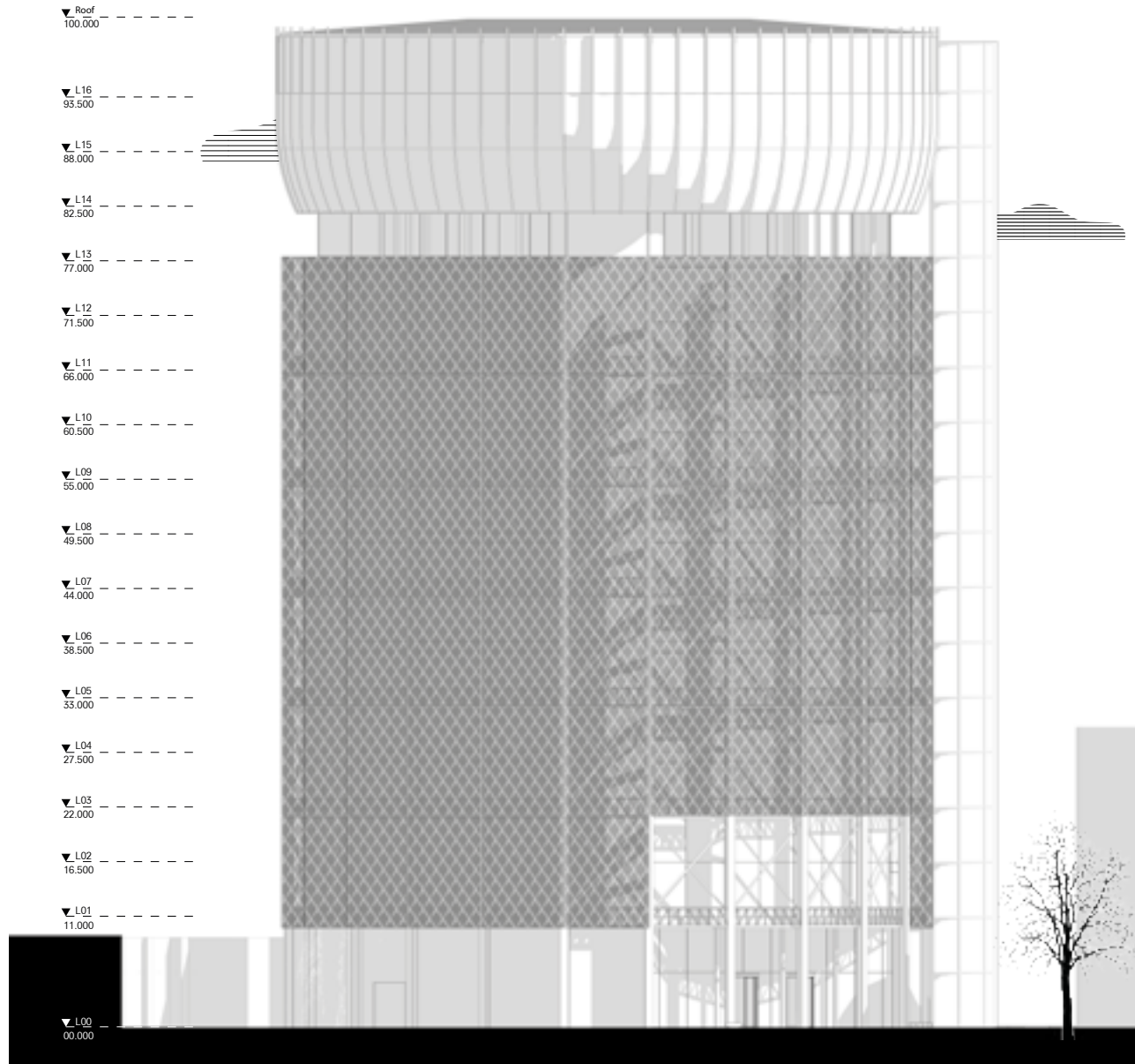

intermezzo

FACADE STRUCTURE

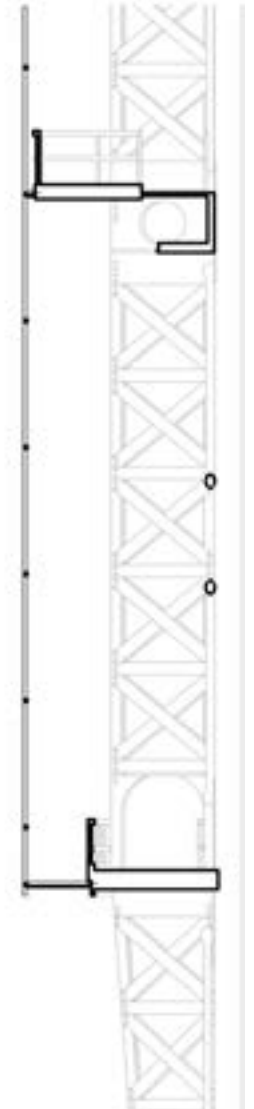
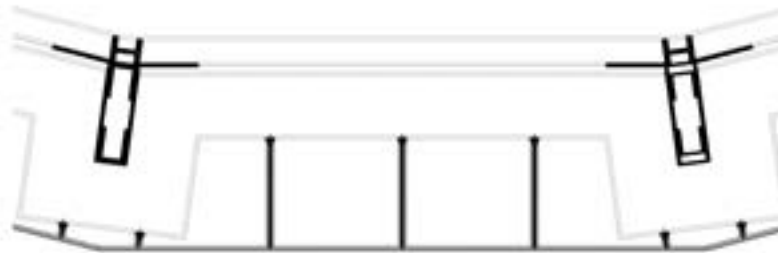
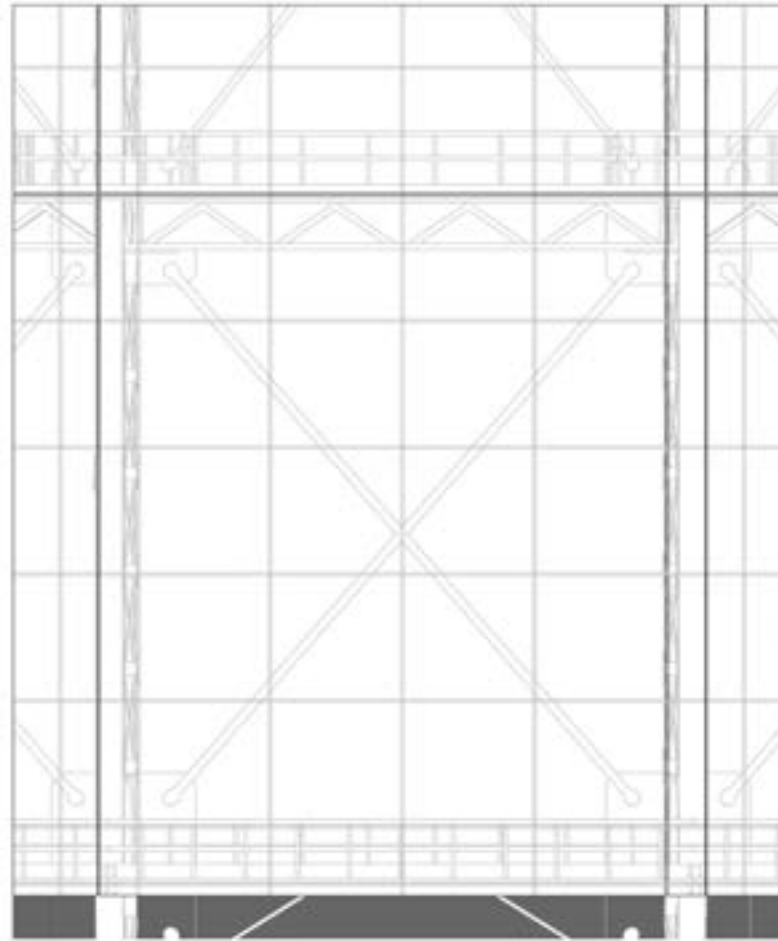
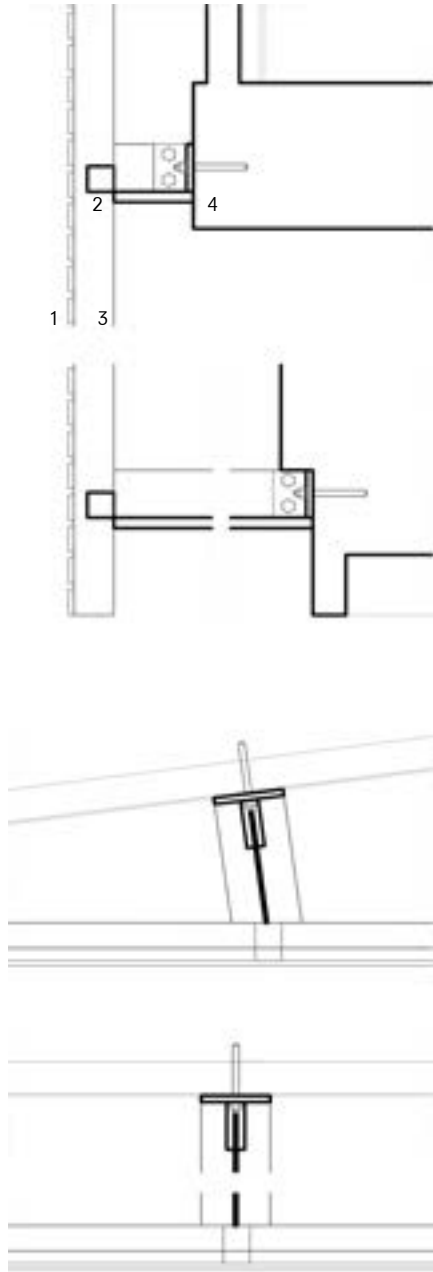

STEEL FRAME CONSTRUCTION 1:50

- 1 metal mesh 4 mm
(70%-30% transparency)
- 2 steel RHS 40 x 40 mm
- 3 steel RHS 40 x 60 mm
- 4 steel T-profile 20 x 8 mm



2 4
1 3

intermezzo

FACADE STRUCTURE

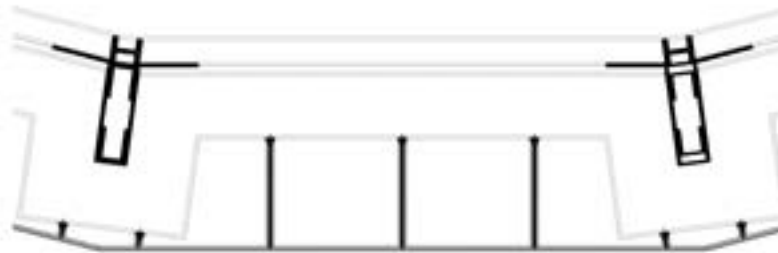
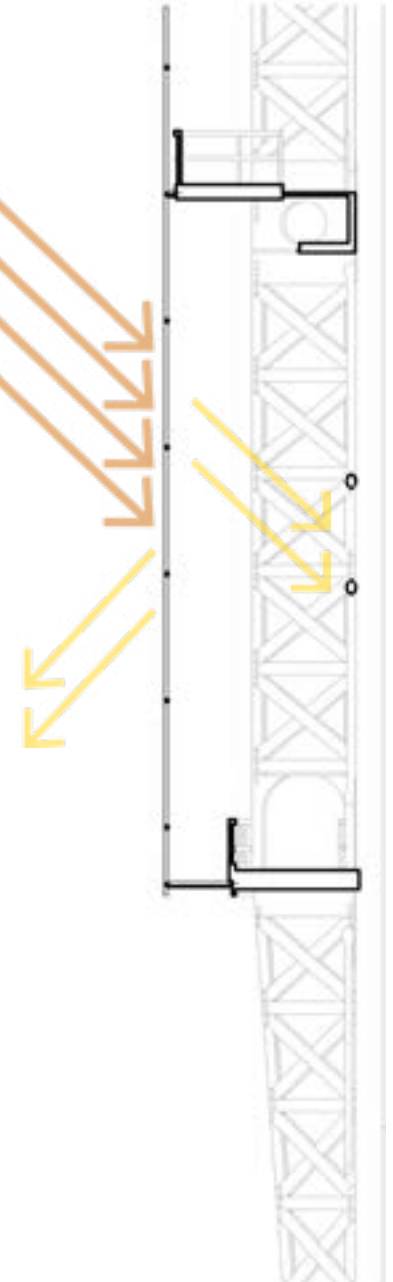
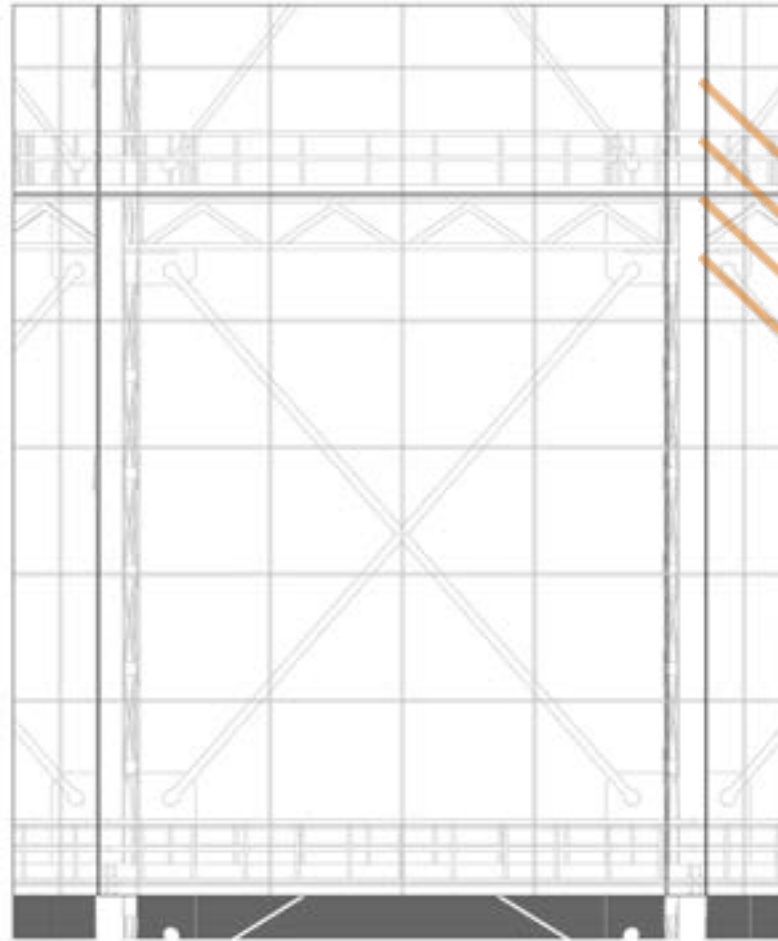
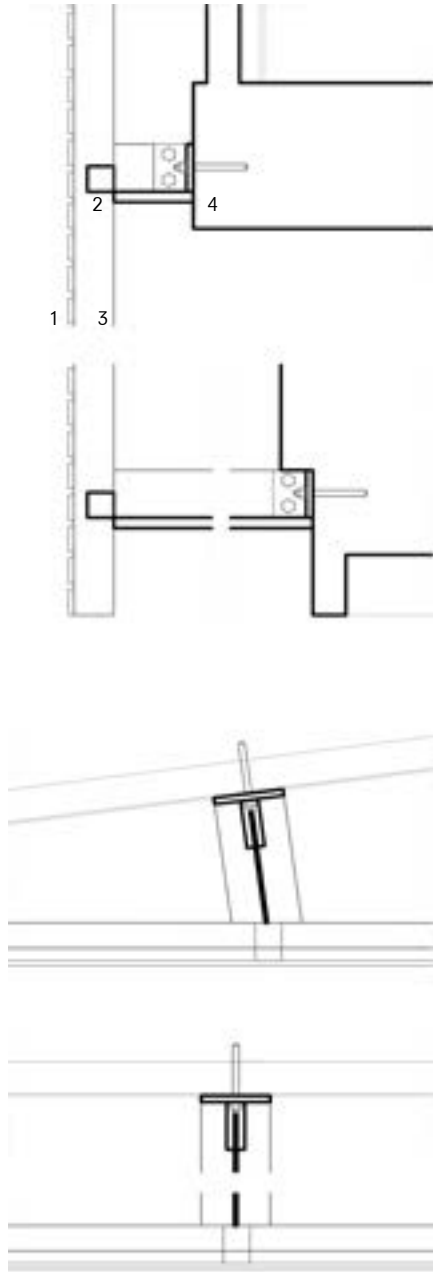

intermezzo

FACADE STRUCTURE

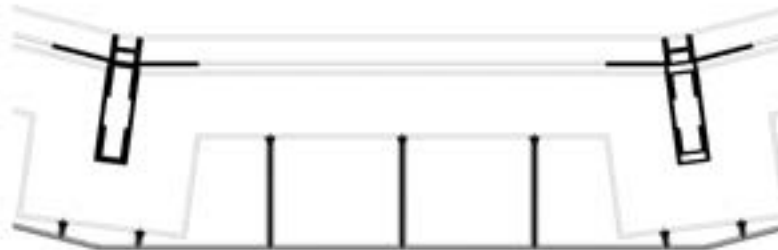
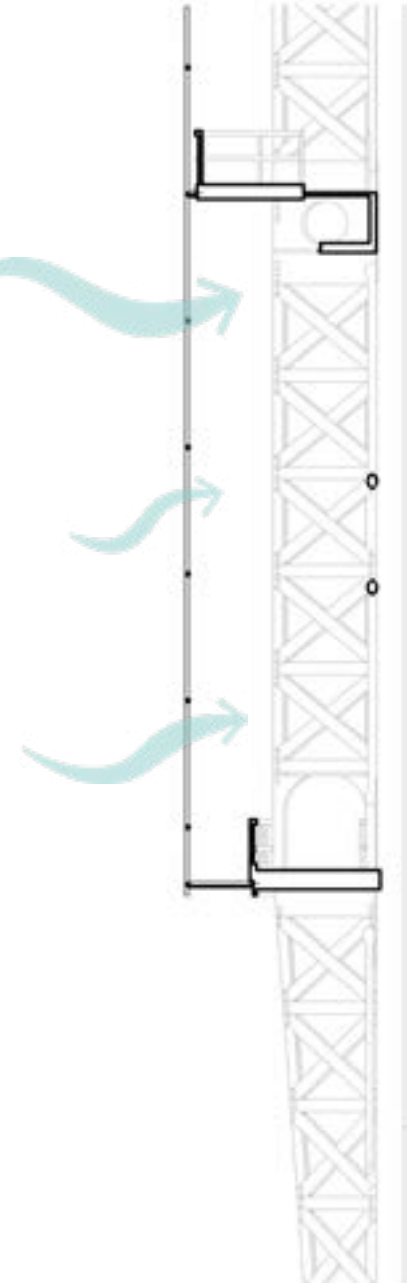
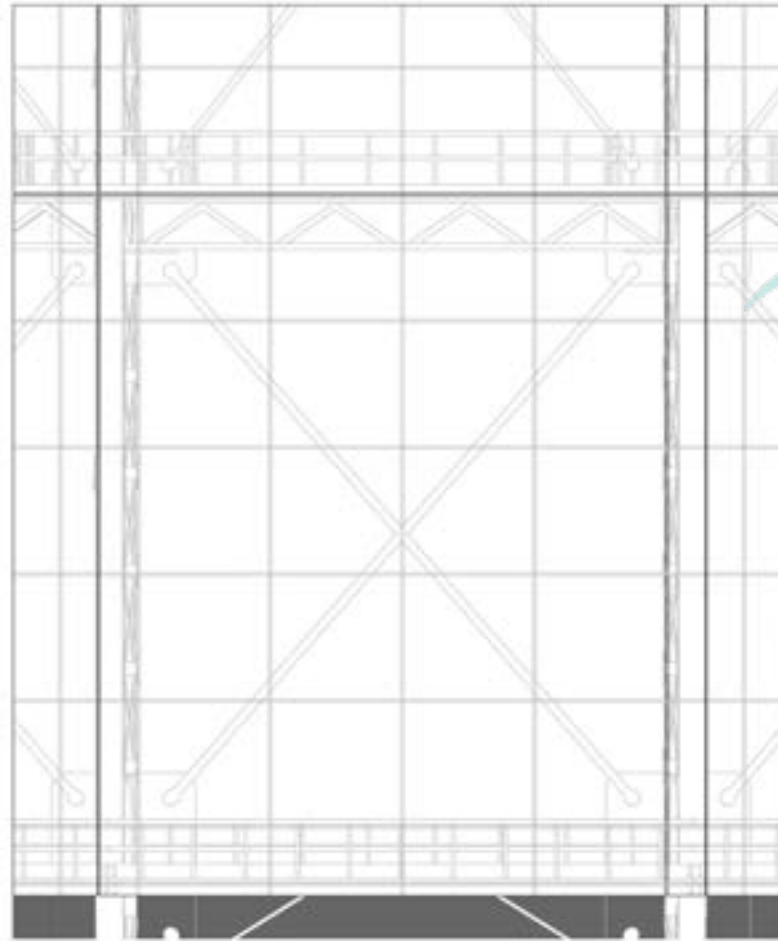
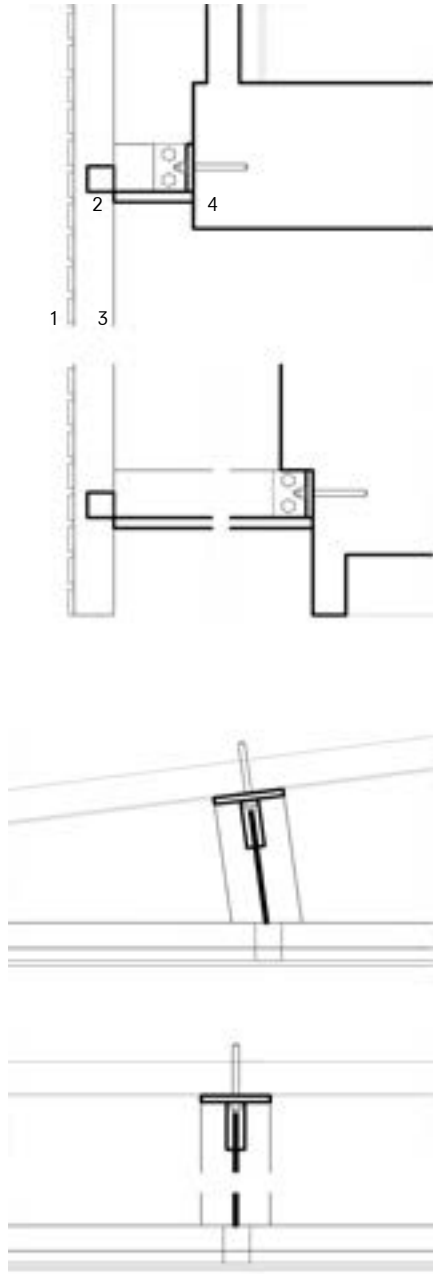

intermezzo

FACADE STRUCTURE

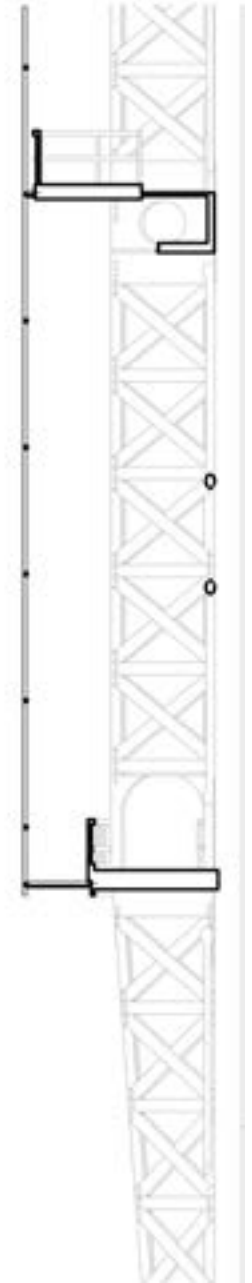
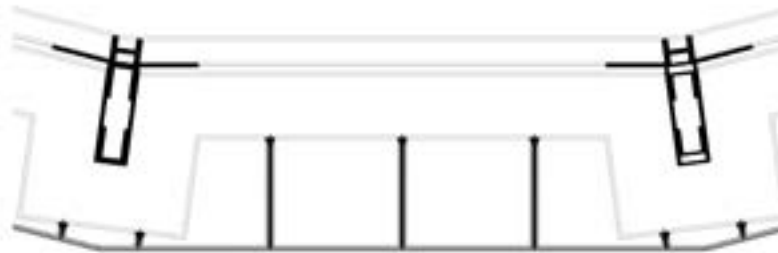
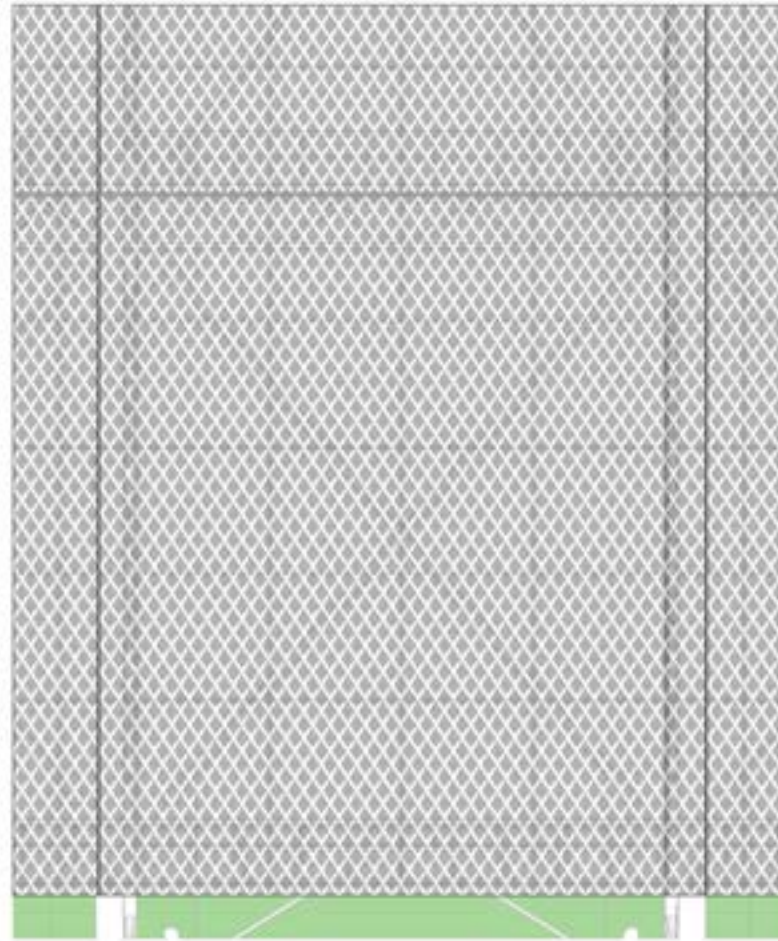
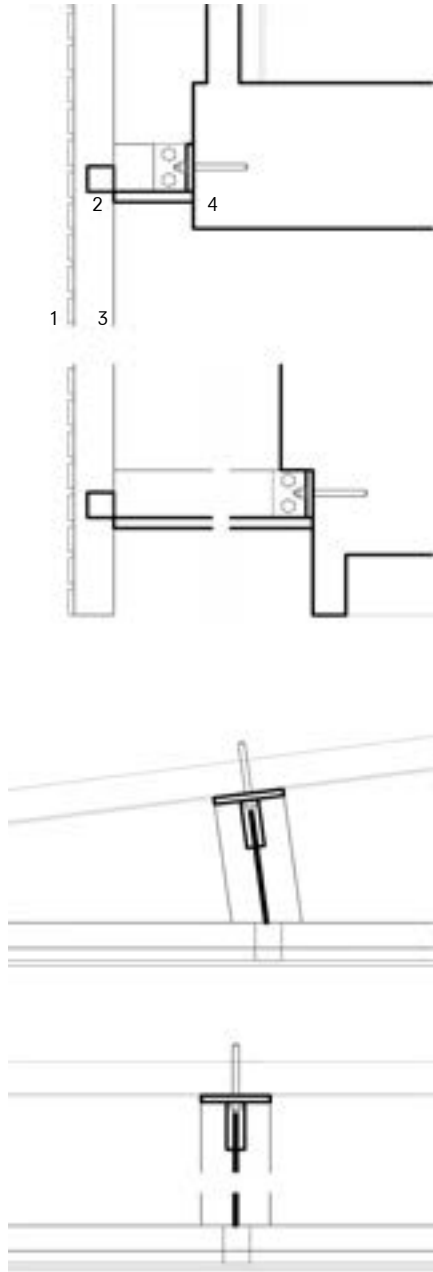

intermezzo

FACADE STRUCTURE

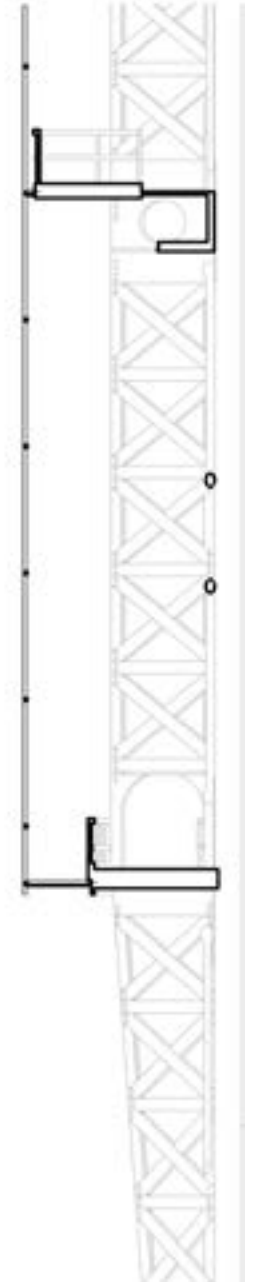
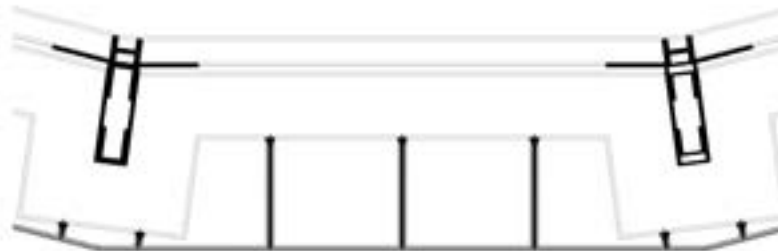
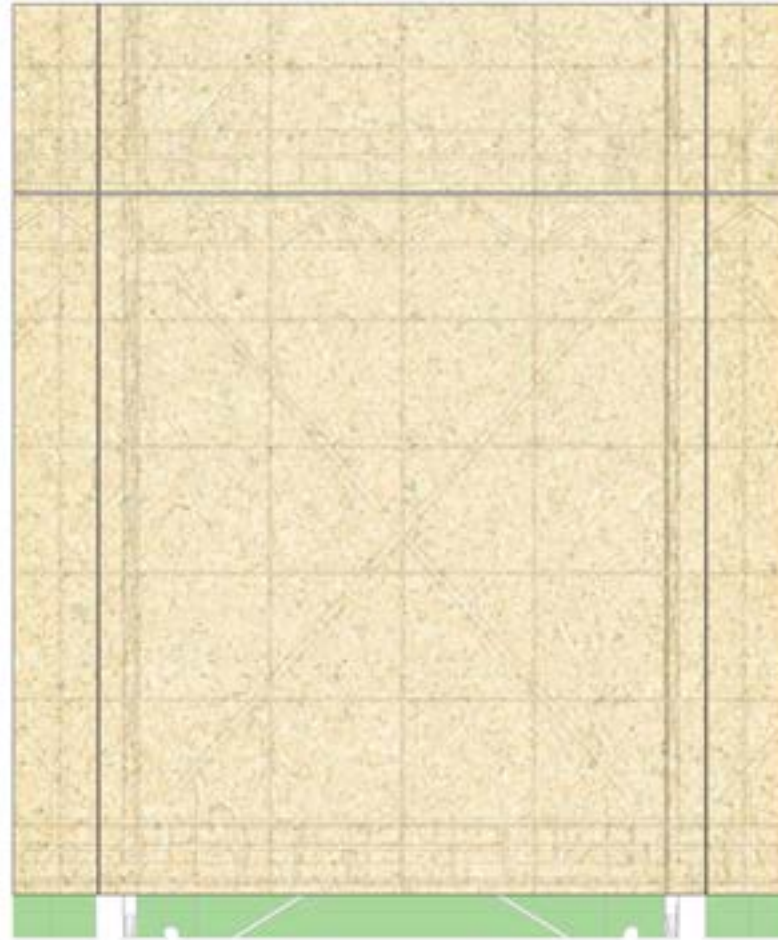
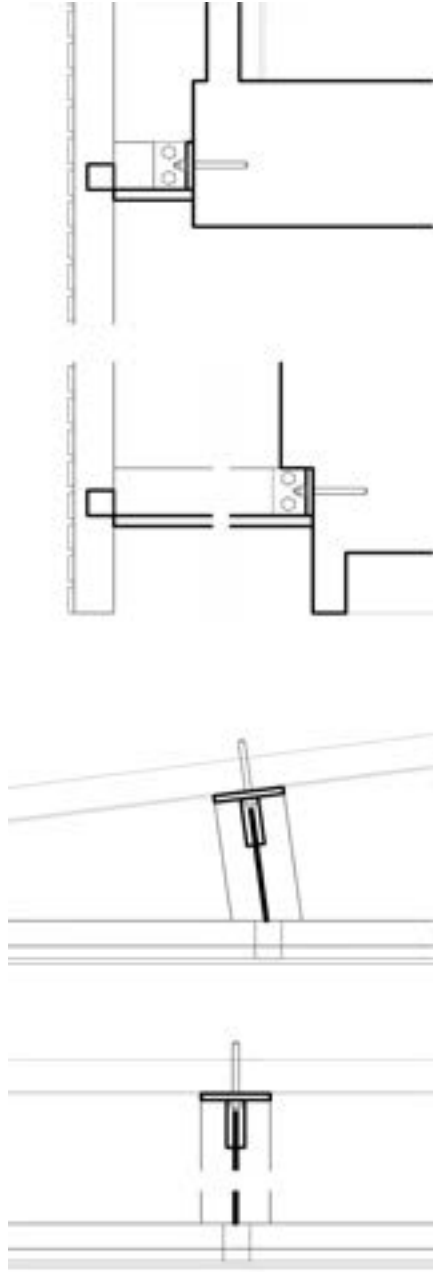

intermezzo

FACADE STRUCTURE

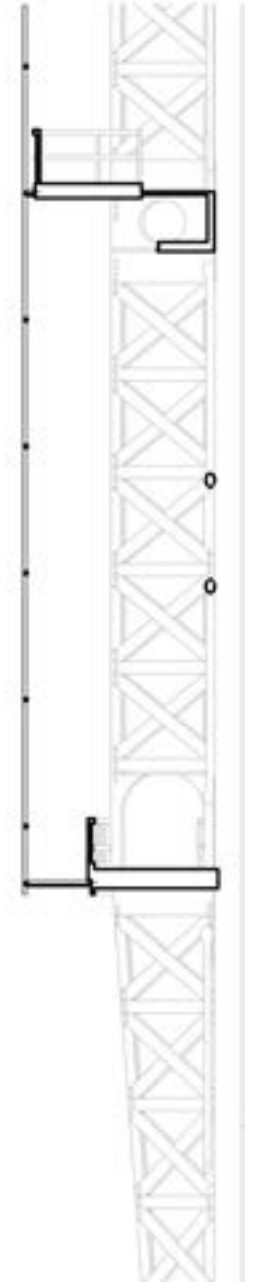
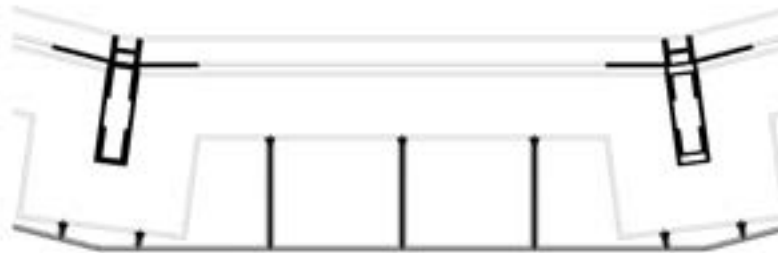
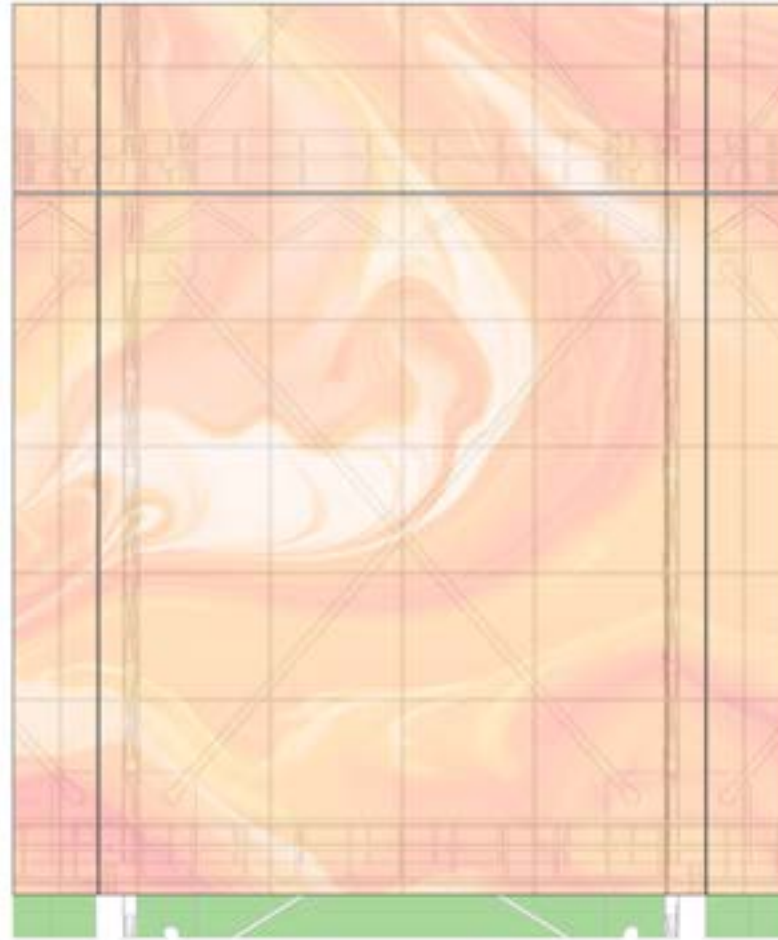
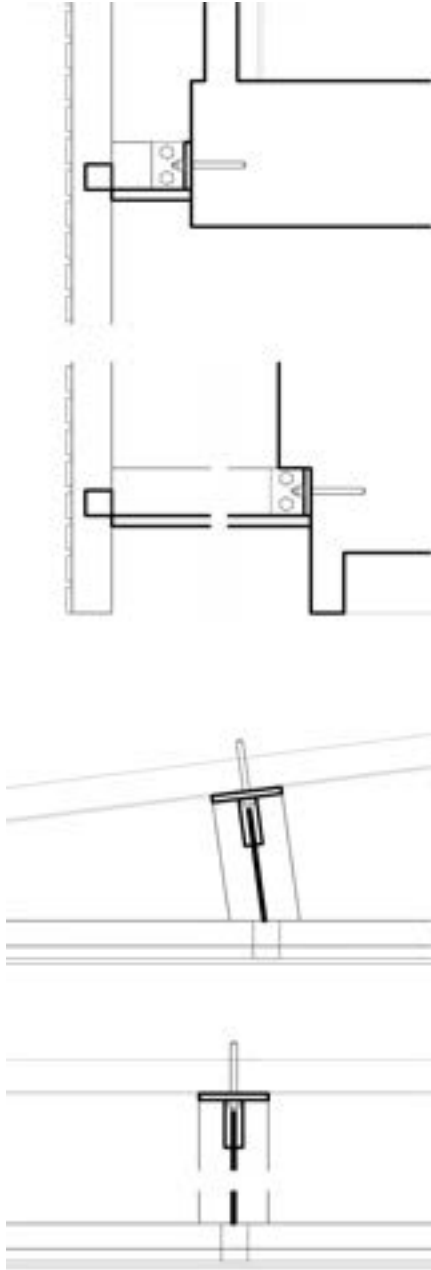

intermezzo

FACADE STRUCTURE

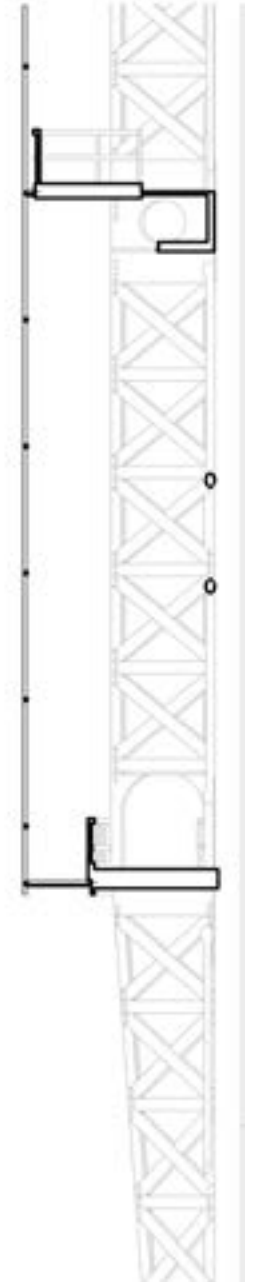
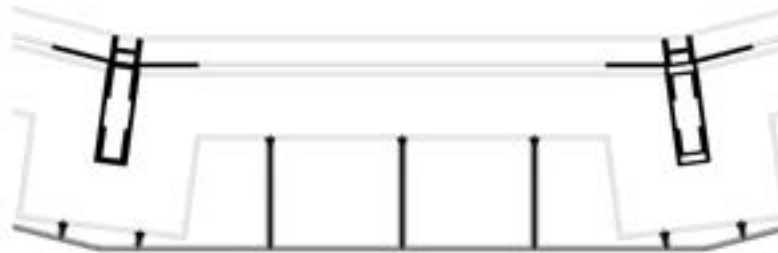
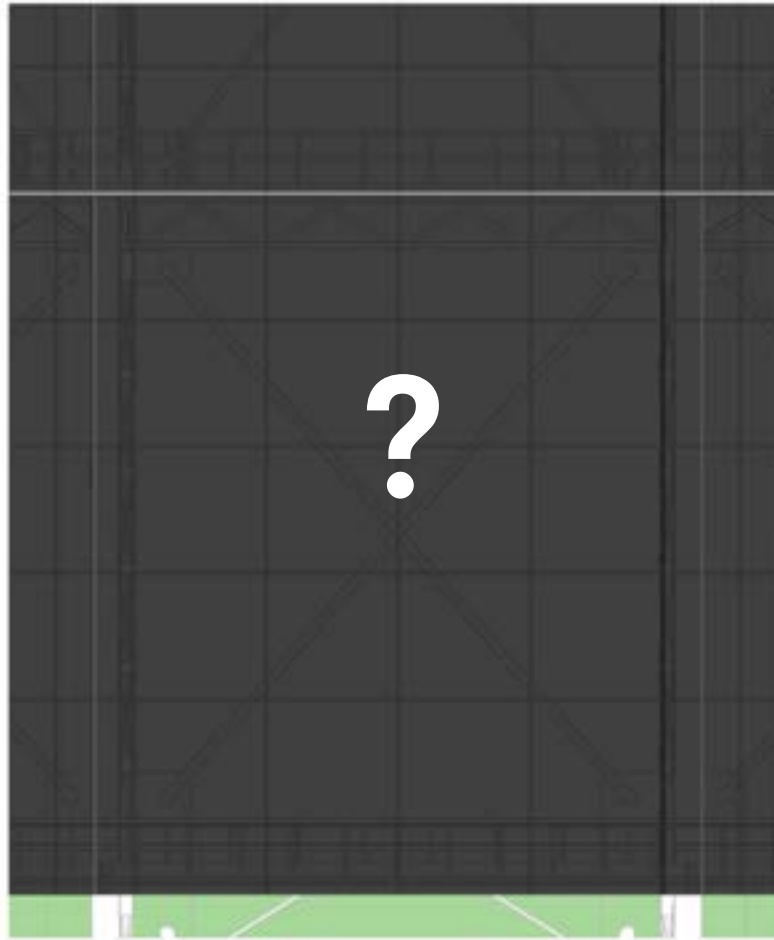
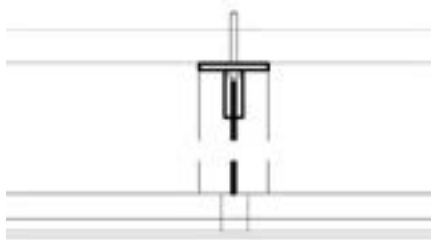
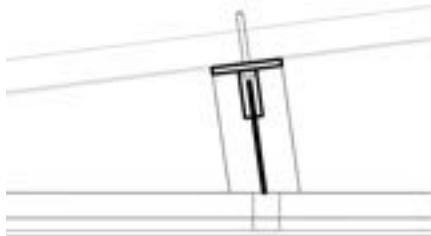
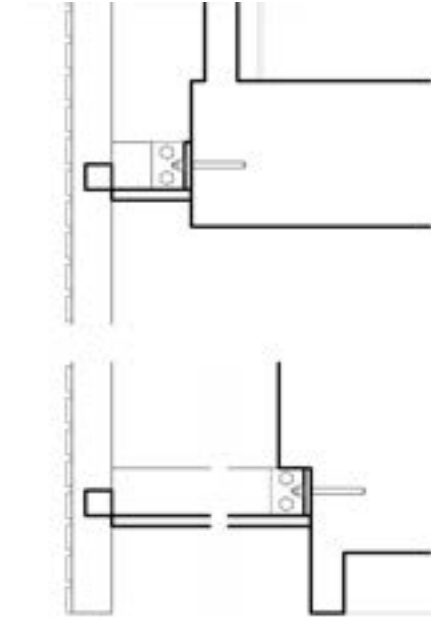

the plinth

ENTRANCE



the plinth
ENTRANCE



the plinth

GROUND FLOOR

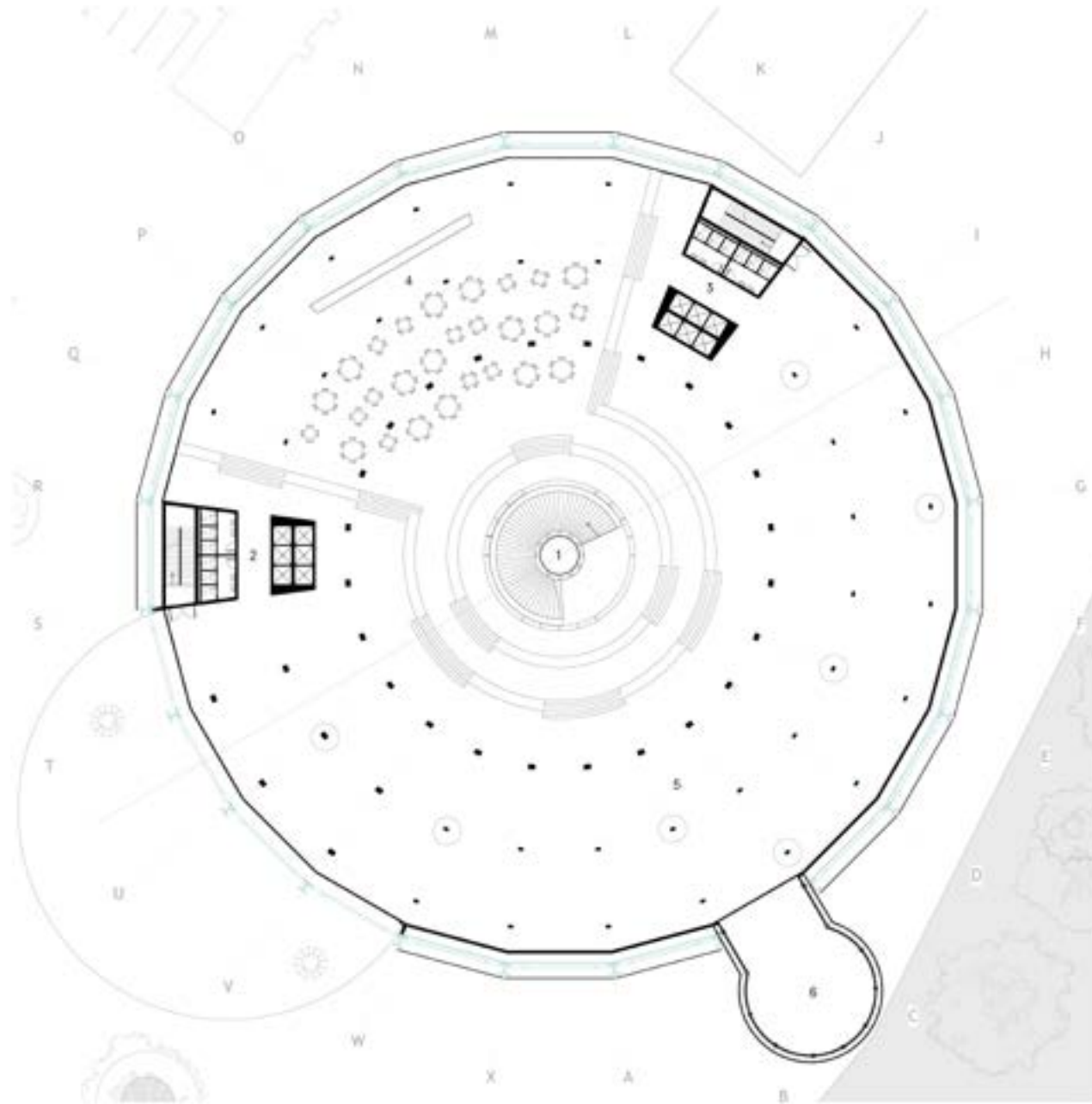

LEGEND

- 1 central circulation
- 2 West circulation core
- 3 North circulation core
- 4 cafeteria
- 5 foyer
- 6 material lift

DRAWING

Floor plan 1

ARCHITECT Kalina Matova

DATE 07/11/2024

SCALE 1/200

NORTH ▲

PROJECT Material Vault

CLIENT BAM, EUREF, SMB

LOCATION EUREF Campus Berlin, DE

the spine
KEY SPACE



the spine
CONSTRUCTION

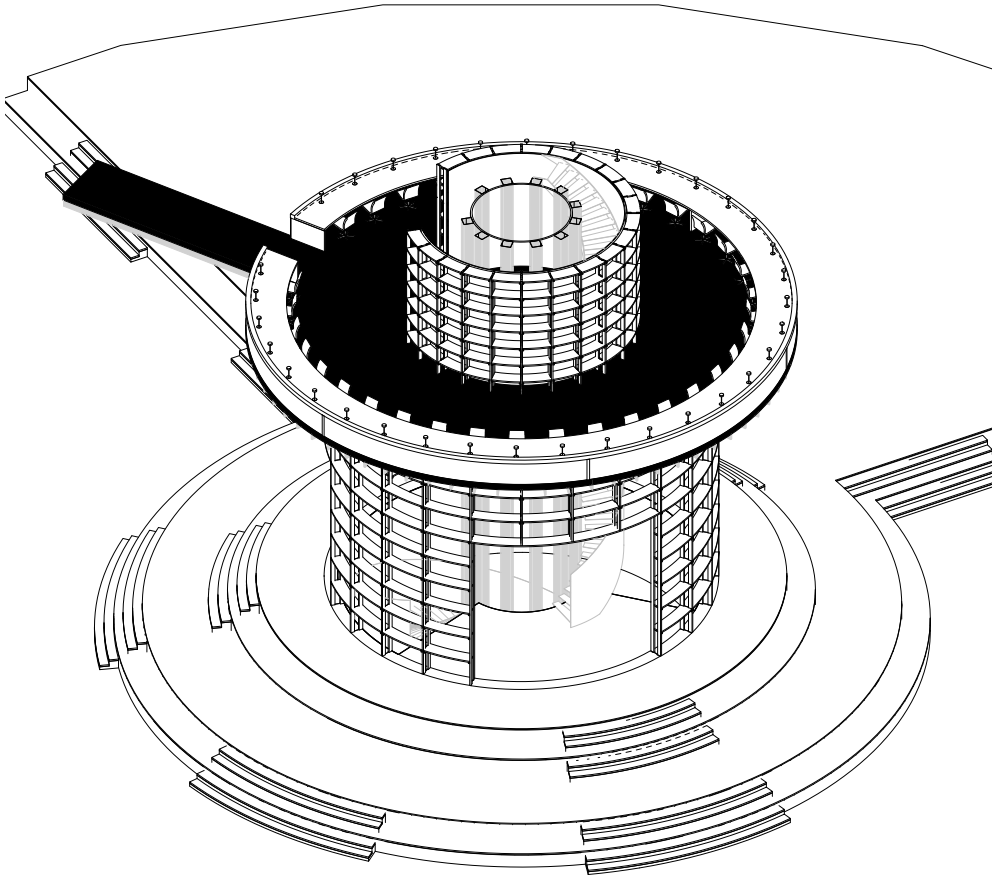

DRAWING	Axonometric drawing
<hr/>	
ARCHITECT	Kalina Matova
DATE	07/11/2024
SCALE	1/50
NORTH	▲
<hr/>	
PROJECT	Material Vault
CLIENT	BAM, EUREF, SMB
LOCATION	EUREF Campus Berlin, DE

the spine

CONSTRUCTION

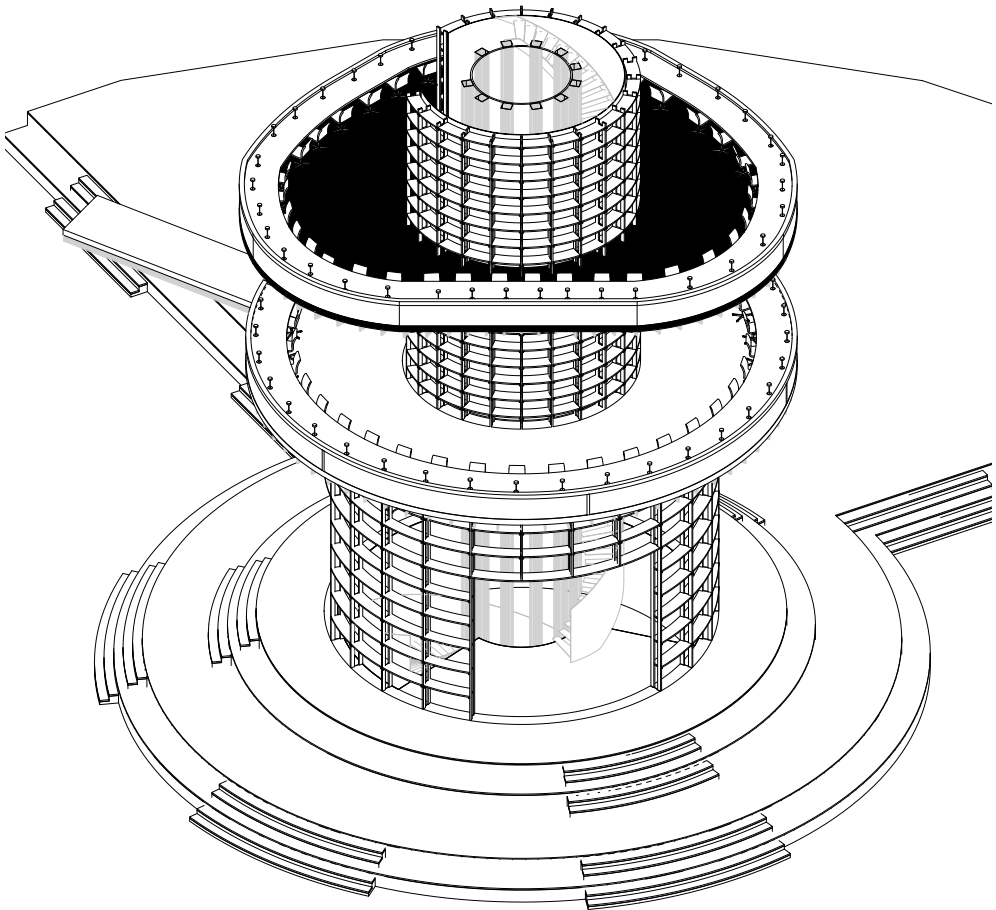

DRAWING
Axonometric drawing

ARCHITECT Kalina Matova
DATE 07/11/2024
SCALE 1/50
NORTH ▲

PROJECT Material Vault
CLIENT BAM, EUREF, SMB
LOCATION EUREF Campus Berlin, DE

the spine

STUDY SPACE



the spine
PERIPHERY

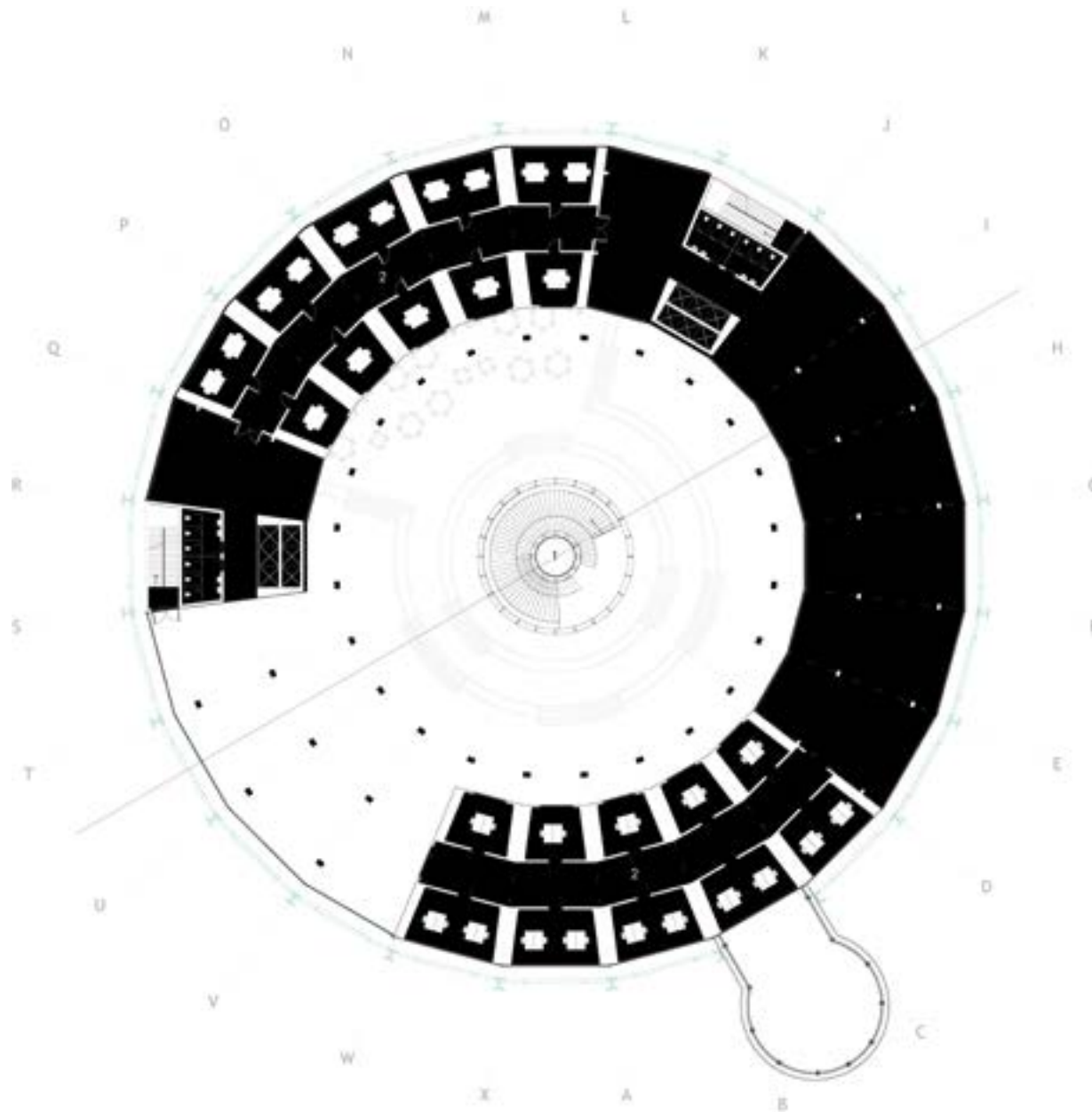

LEGEND

- 1 central circulation
- 2 offices

DRAWING

Floor plan 2

ARCHITECT Kalina Matova
DATE 07/11/2024
SCALE 1/200
NORTH ▲

PROJECT Material Vault
CLIENT BAM, EUREF, SMB
LOCATION EUREF Campus Berlin, DE

the spine
PERIPHERY

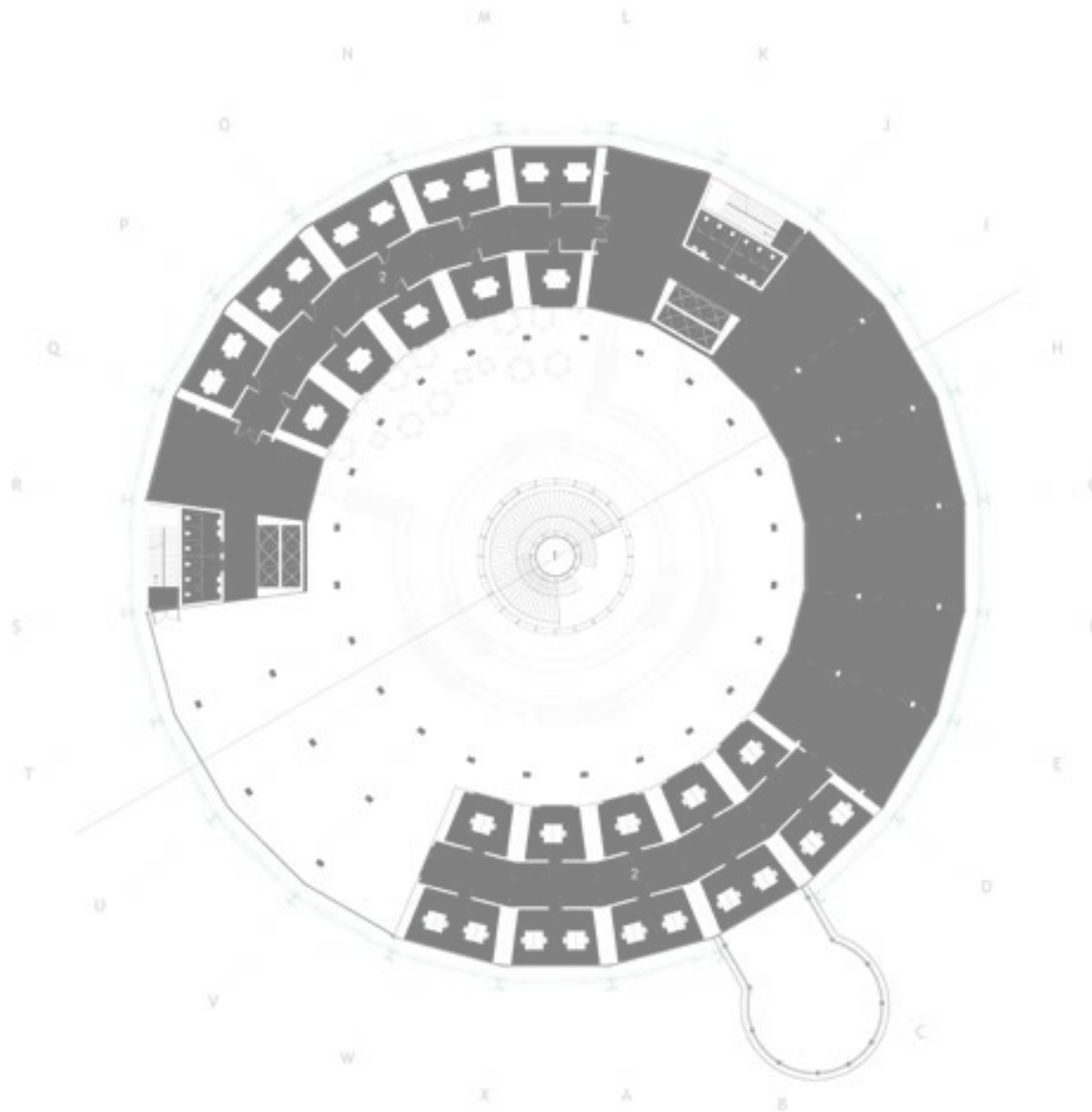

LEGEND

- 1 central circulation
- 2 offices



DRAWING

Floor plan 2

ARCHITECT Kalina Matova
DATE 07/11/2024
SCALE 1/200
NORTH ▲

PROJECT Material Vault
CLIENT BAM, EUREF, SMB
LOCATION EUREF Campus Berlin, DE

the spine
PERIPHERY

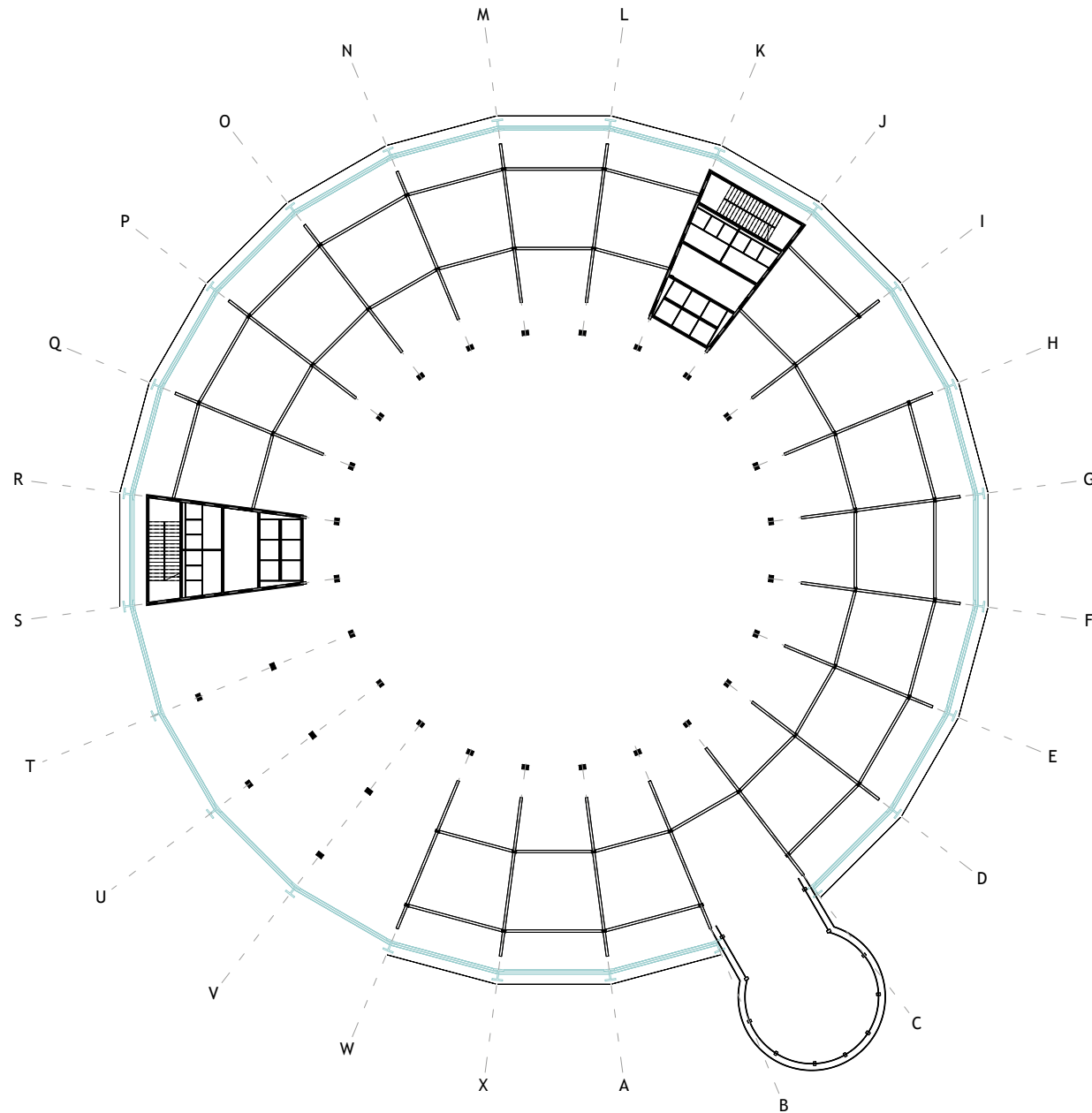

DRAWING
Structural plan level 1

ARCHITECT Kalina Matova
DATE 07/11/2024
SCALE 1/200
NORTH ▲

PROJECT Material Vault
CLIENT BAM, EUREF, SMB
LOCATION EUREF Campus Berlin, DE

the spine
PERIPHERY

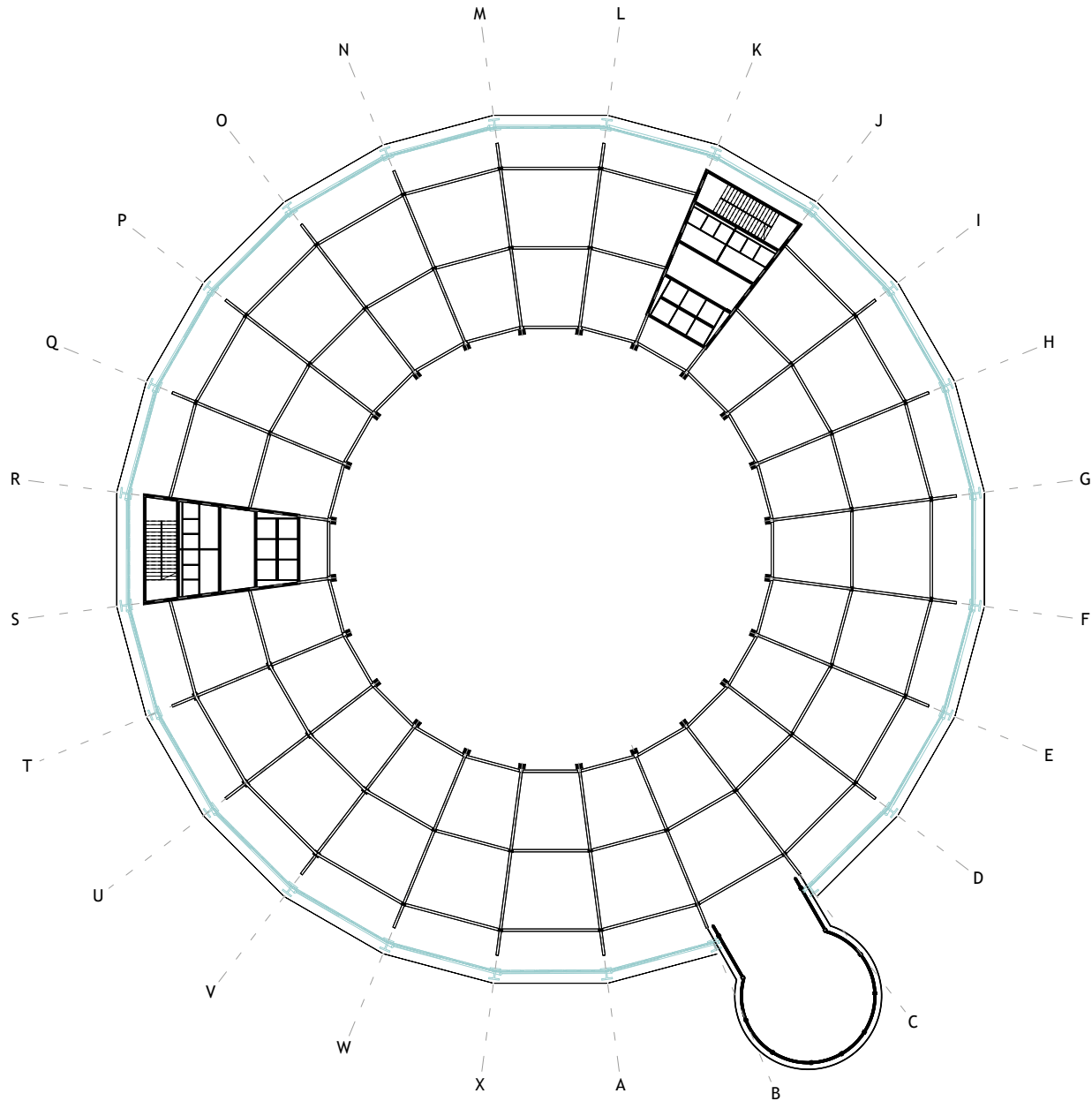

DRAWING
Structural plan level 2

ARCHITECT Kalina Matova
DATE 07/11/2024
SCALE 1/200
NORTH ▲

PROJECT Material Vault
CLIENT BAM, EUREF, SMB
LOCATION EUREF Campus Berlin, DE

the spine
PERIPHERY

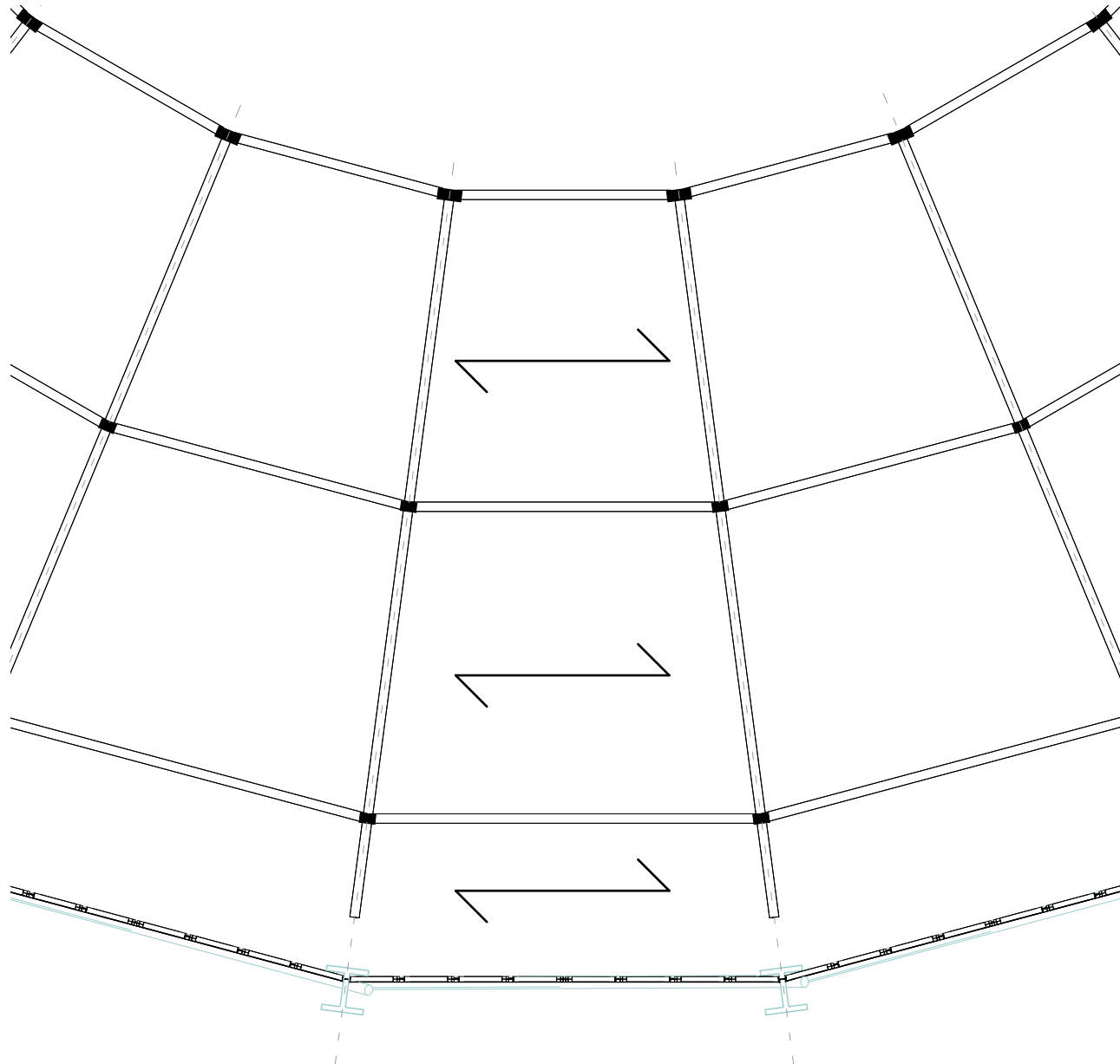

DRAWING
Structural plan level 2

ARCHITECT Kalina Matova
DATE 07/11/2024
SCALE 1/50
NORTH ▲

PROJECT Material Vault
CLIENT BAM, EUREF, SMB
LOCATION EUREF Campus Berlin, DE

the spine
PERIPHERY

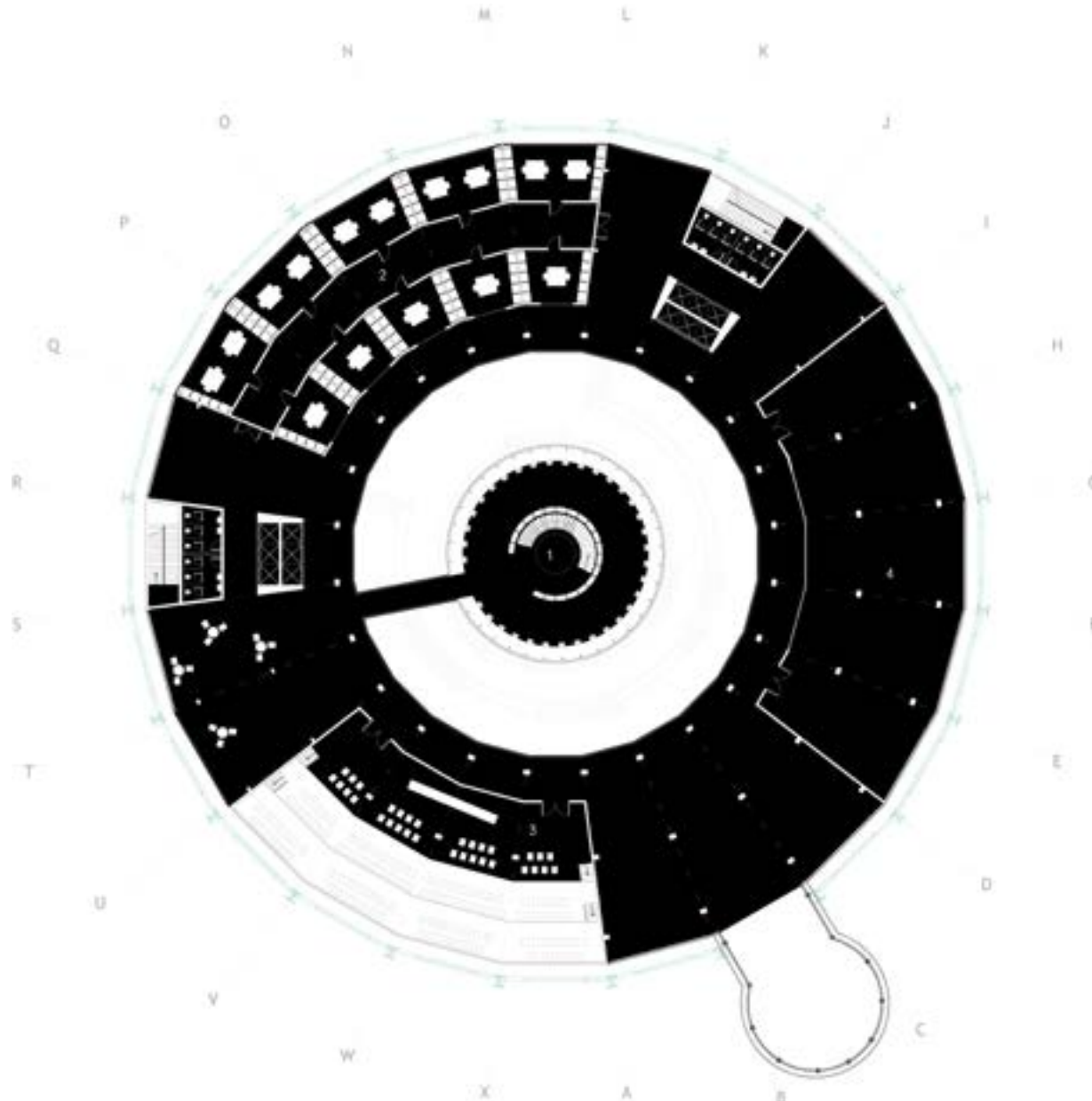

-
- LEGEND**
- 1 central circulation
 - 2 offices
 - 3 auditorium
 - 4 C lab (curing)

DRAWING
Floor plan 3

ARCHITECT	Kalina Matova
DATE	07/11/2024
SCALE	1/200
NORTH	▲

PROJECT	Material Vault
CLIENT	BAM, EUREF, SMB
LOCATION	EUREF Campus Berlin, DE

the spine
LABS



the spine and the crown

RELATION

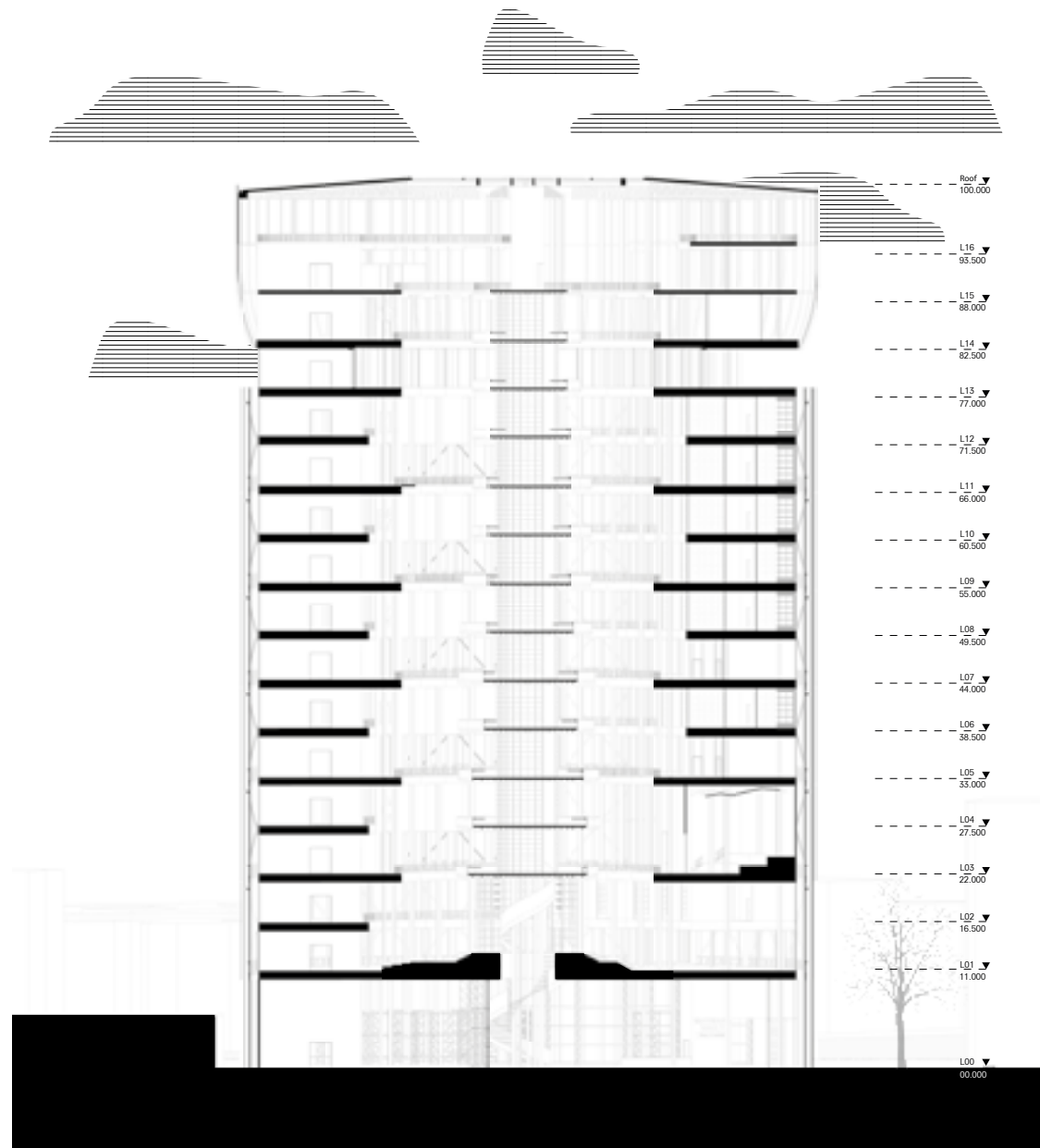

DRAWING Section 1

ARCHITECT	Kalina Matova
DATE	07/11/2024
SCALE	1/200
NORTH	←
PROJECT	Material Vault
CLIENT	BAM, EUREF, SMB
LOCATION	EUREF Campus Berlin, DE

the spine and the crown

INTERMEDIATE SPACE

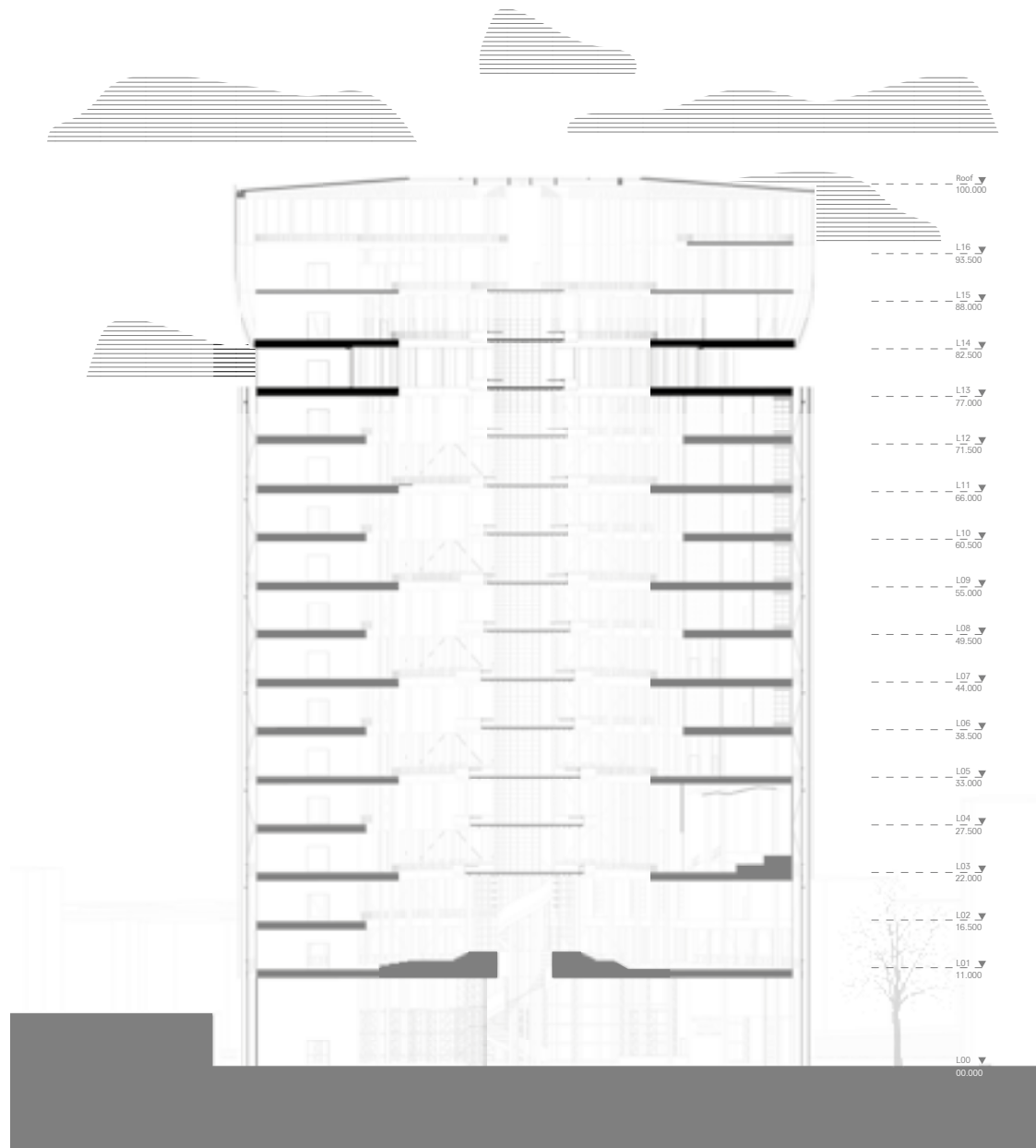

DRAWING
Section 1

ARCHITECT Kalina Matova
DATE 07/11/2024
SCALE 1/200
NORTH ◀

PROJECT Material Vault
CLIENT BAM, EUREF, SMB
LOCATION EUREF Campus Berlin, DE

the spine and the crown

INTERMEDIATE SPACE

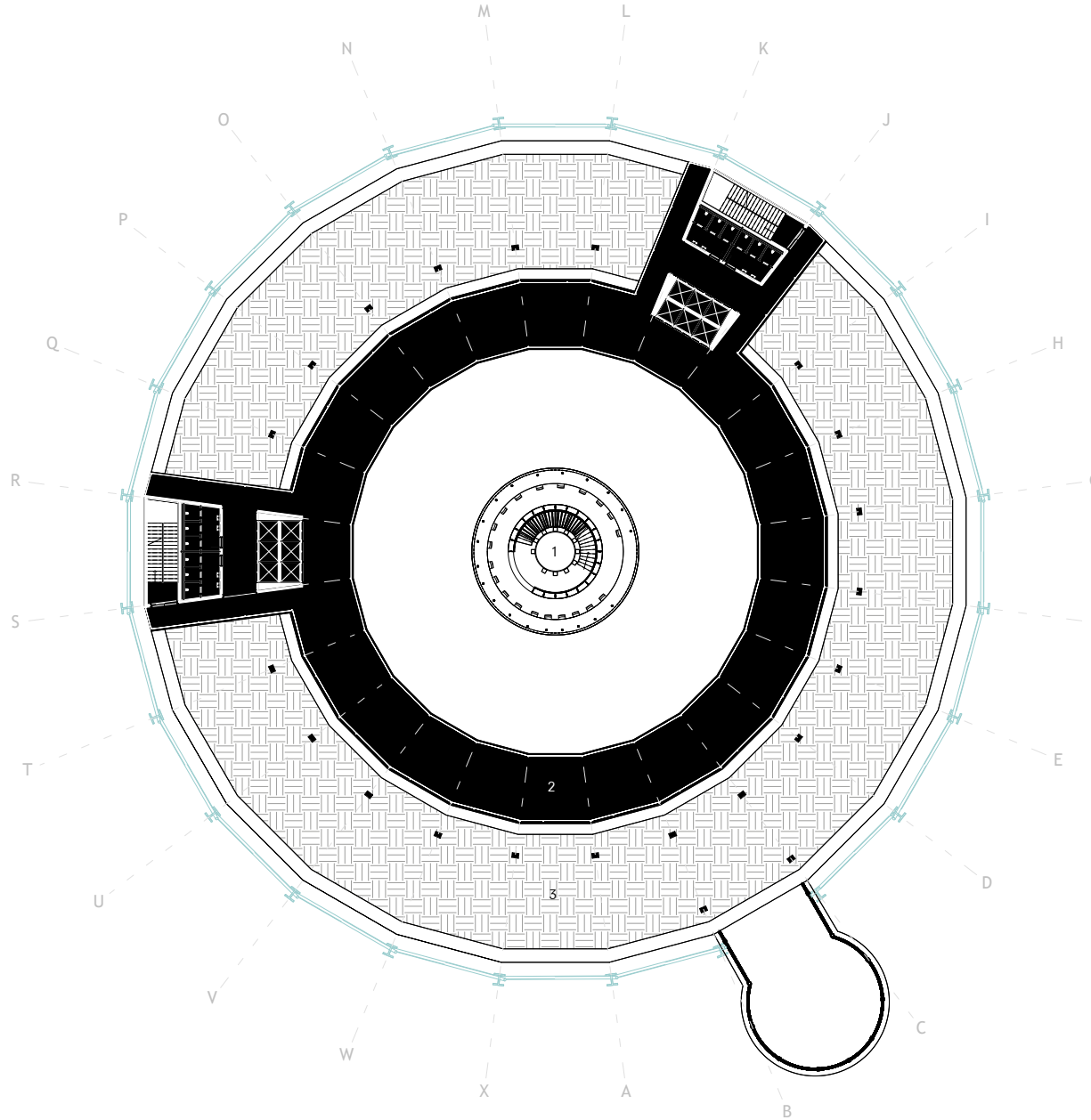

LEGEND

- 1 central circulation
- 2 reflection space
- 3 green roof

DRAWING

Floor plan 13

ARCHITECT	Kalina Matova
DATE	07/11/2024
SCALE	1/200
NORTH	▲
PROJECT	Material Vault
CLIENT	BAM, EUREF, SMB
LOCATION	EUREF Campus Berlin, DE

the spine and the crown

INTERMEDIATE SPACE



the crown
WORKSHOP

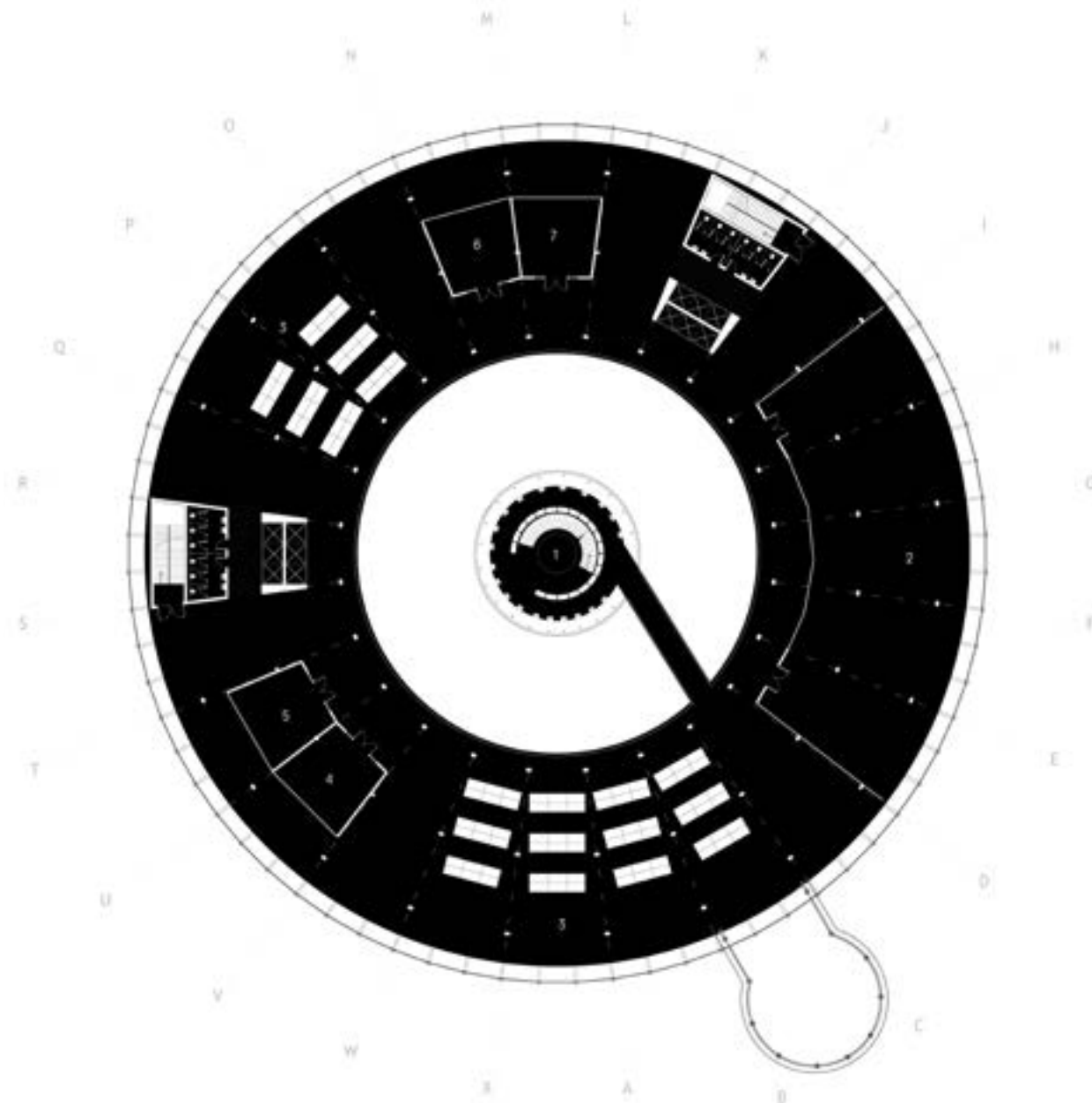

LEGEND

- 1 central circulation
- 2 WS (public workshop)
- 3 work tables
- 4 lasercut lab
- 5 CNC/3D printing lab
- 6 electronics lab
- 7 printing lab

DRAWING

Floor plan 14

ARCHITECT Kalina Matova

DATE 07/11/2024

SCALE 1/200

NORTH ▲

PROJECT Material Vault

CLIENT BAM, EUREF, SMB

LOCATION EUREF Campus Berlin, DE

the crown

SHOWROOM



LEGEND

- 1 central circulation
- 2 business stands
- 3 exhibition

DRAWING

Floor plan 15

ARCHITECT	Kalina Matova
DATE	07/11/2024
SCALE	1/200
NORTH	▲

PROJECT	Material Vault
CLIENT	BAM, EUREF, SMB
LOCATION	EUREF Campus Berlin, DE

the crown

SHOWROOM



the plinth, the spine and the crown
COMING TOGETHER



DRAWING
West elevation

ARCHITECT Kalina Matova
DATE 07/11/2024
SCALE 1/200
NORTH ▲

PROJECT Material Vault
CLIENT BAM, EUREF, SMB
LOCATION EUREF Campus Berlin, DE

the plinth, the spine and the crown
COMING TOGETHER

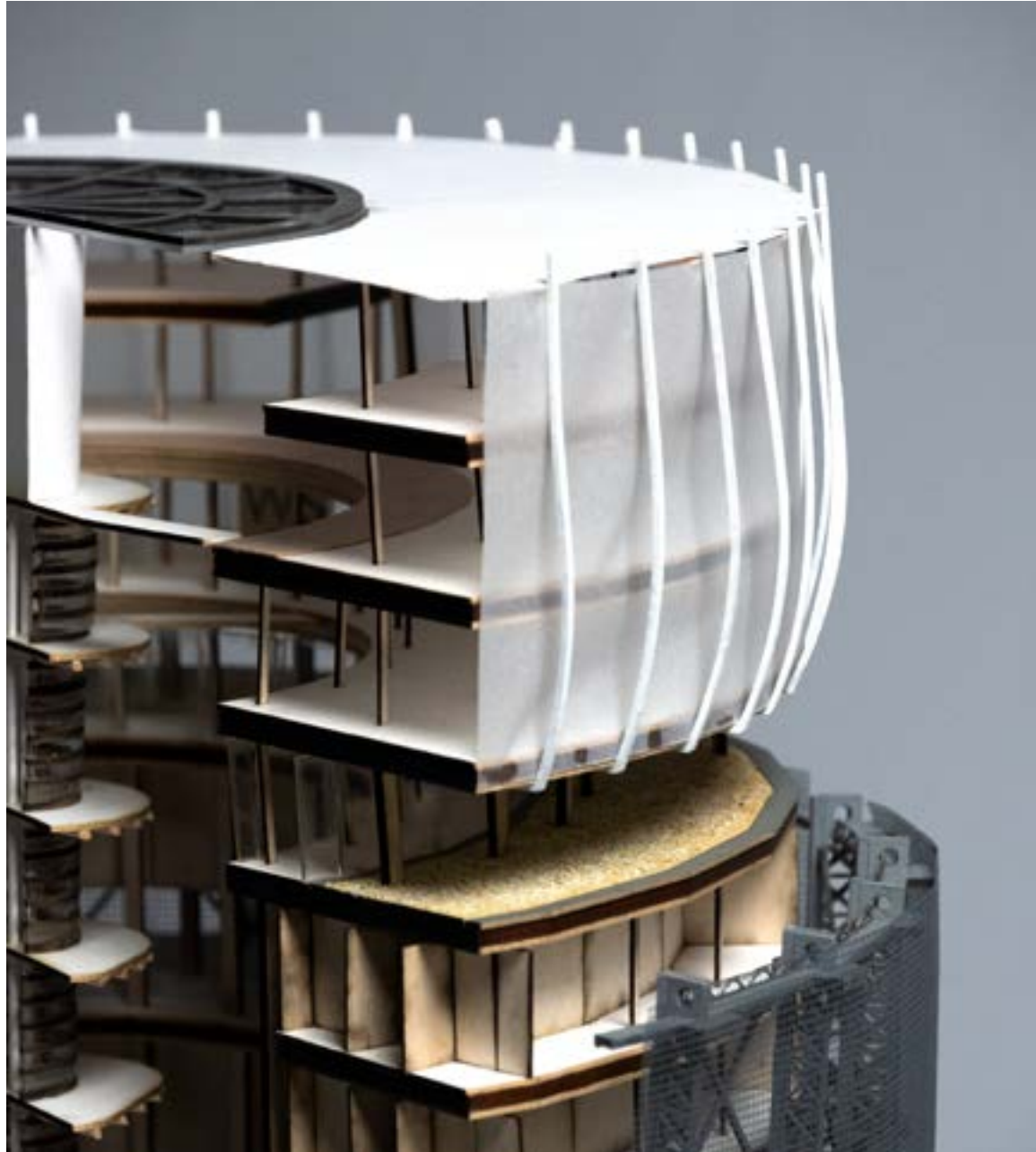

detailing

FACADE CONSTRUCTION 1:50



detailing

CURTAIN WALL TO ROOF

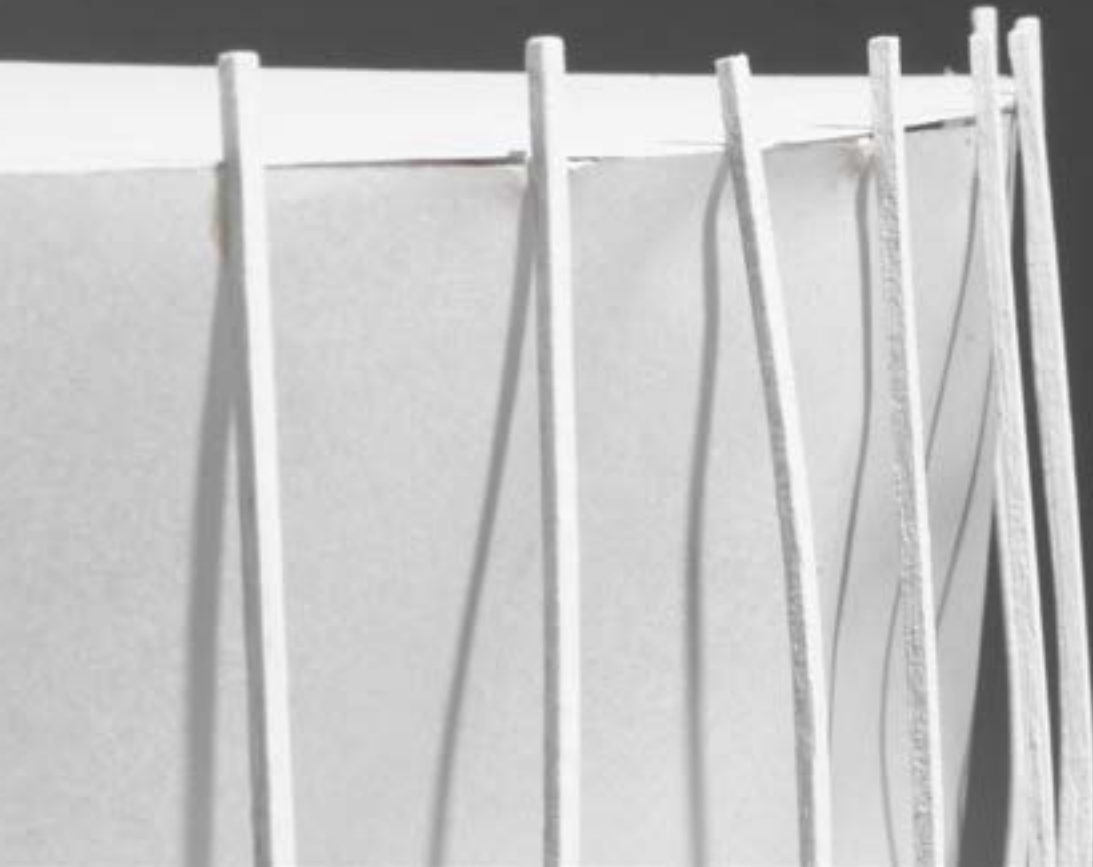

detailing

CURTAIN WALL TO ROOF 1:10

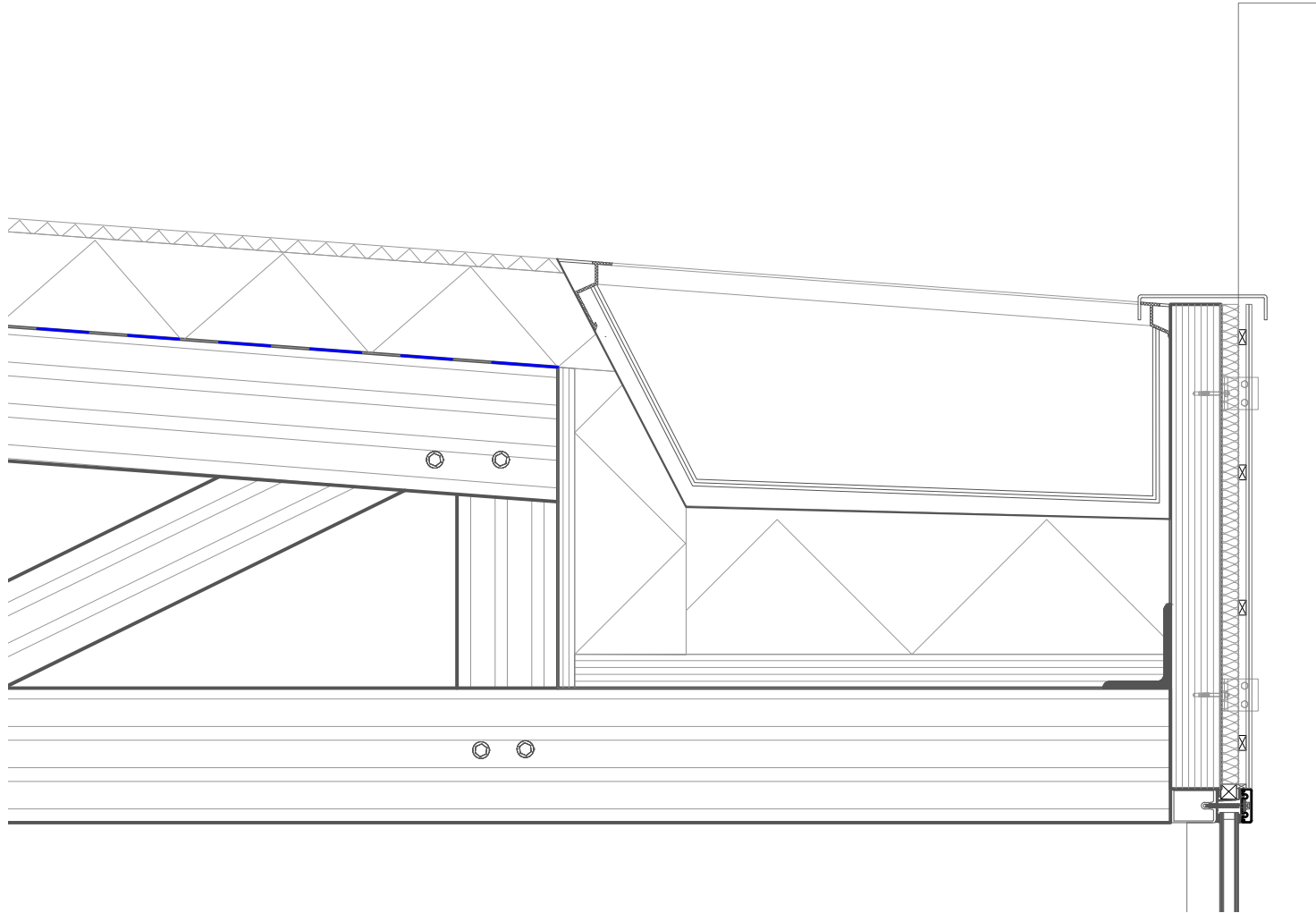

ROOF CONSTRUCTION

1.5mm	sandwich panel on top
20mm	stainless steel sheet super mirror polish
1.5mm	rigid insulation
1.5mm	stainless steel sheet super mirror polish
	GLULAM truss
	sandwich panel on bottom
1.5mm	stainless steel sheet super mirror polish
40mm	rigid insulation
1.5mm	stainless steel sheet super mirror polish
	rain gutter
	downpipe to facade mullions
	steel anchoring
1mm	EPDM membrane

detailing

STEEL ROD FLOOR TO MULLION 1:5

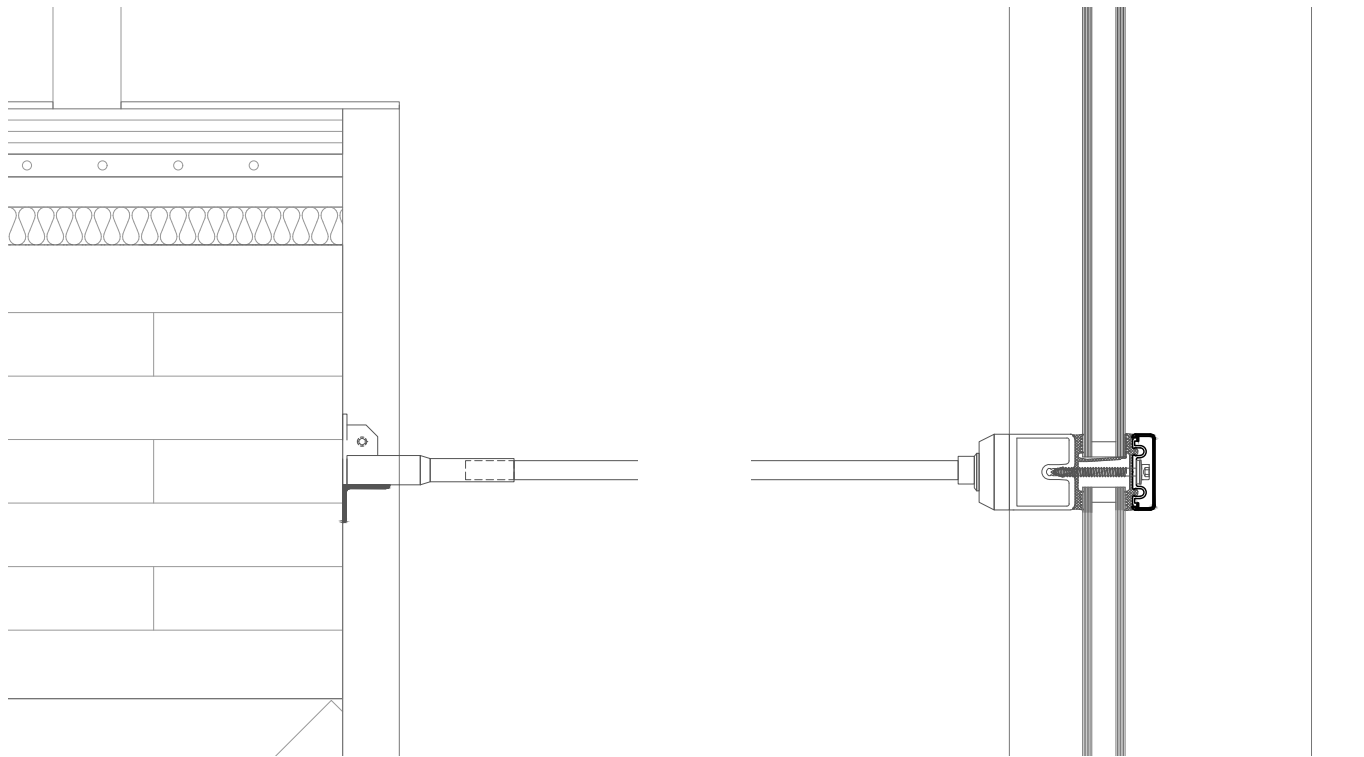

detailing

CURTAIN WALL TO GREEN ROOF



detailing

CUSTOM MULLION TO FLOOR 1:5

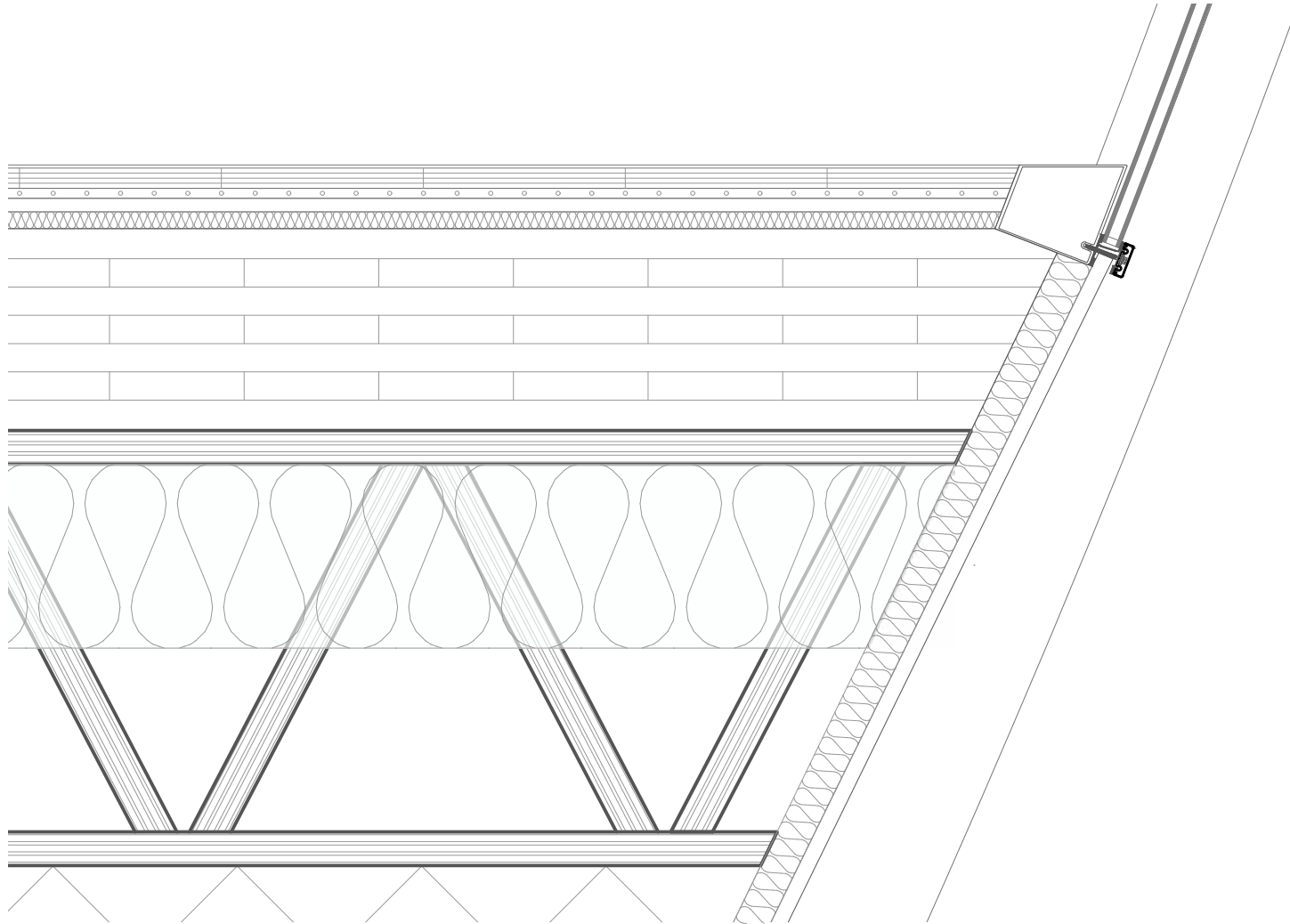

FLOOR CONSTRUCTION

	4.6mm	heavy traffic woven flooring
30 mm		plywood flooring
15mm		underfloor heating system
20mm		floor deck
70mm		acoustic batten
		service void
25mm		rigid insulation
300mm		7 ply CLT floor panel
400mm		suspended ceiling
		HVAC and electrical systems
450mm		GLULAM beam
		Hidden aluminum T-profile connection
30mm		plasterboards

detailing

GREEN ROOF PARAPET 1:5

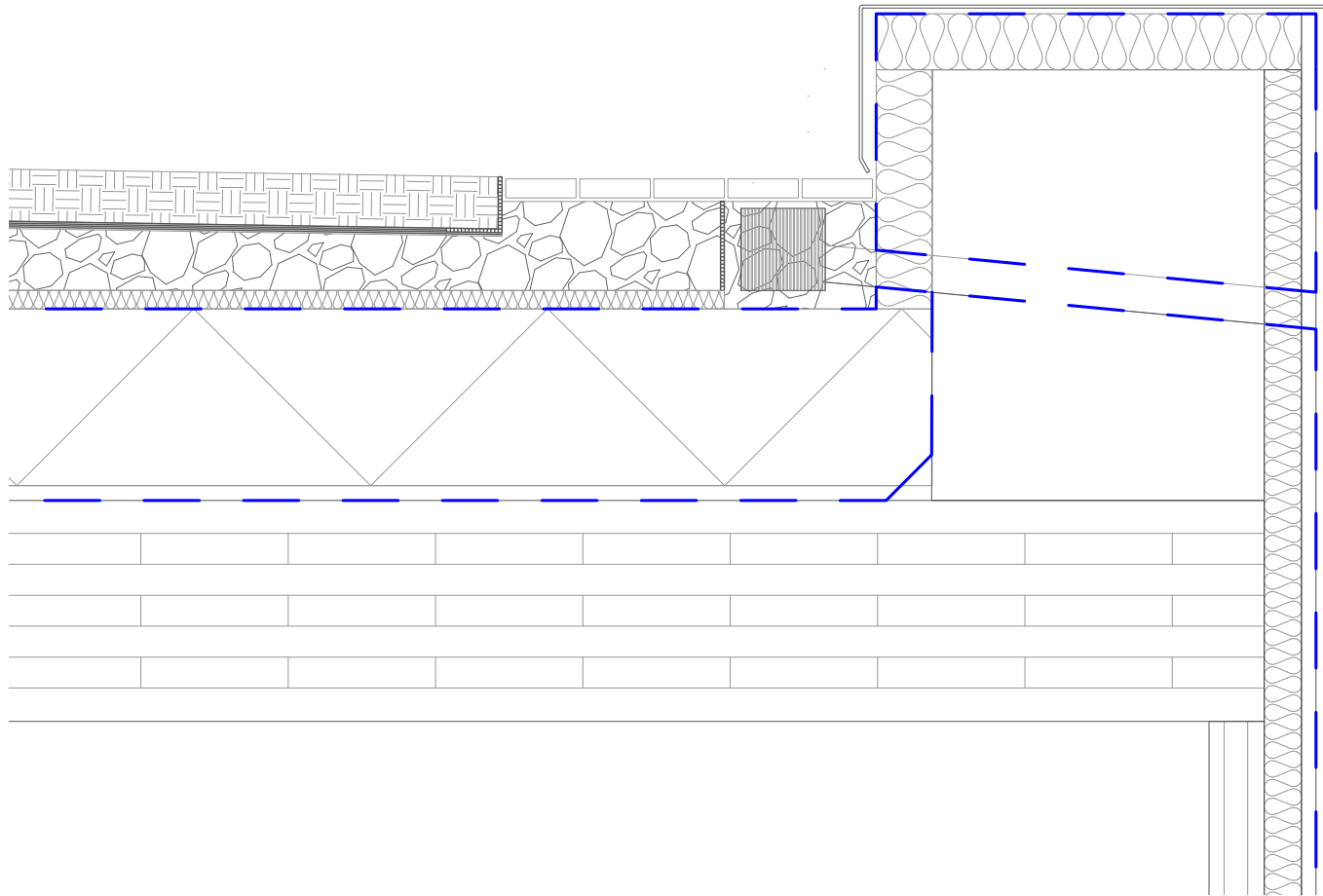

GREEN ROOF CONSTRUCTION

- 63mm custom aluminum window frame
- metal skirting
- concrete skirting
- concrete flags
- drainage channel
- planting
- 180mm substrate
- filter fleece
- 20mm drainage layer
- protective membrane
- 3ply EPDM waterproofing
- separating membrane
- vapour barrier
- separating membrane
- 400mm GLULAM beam

climate
WATER

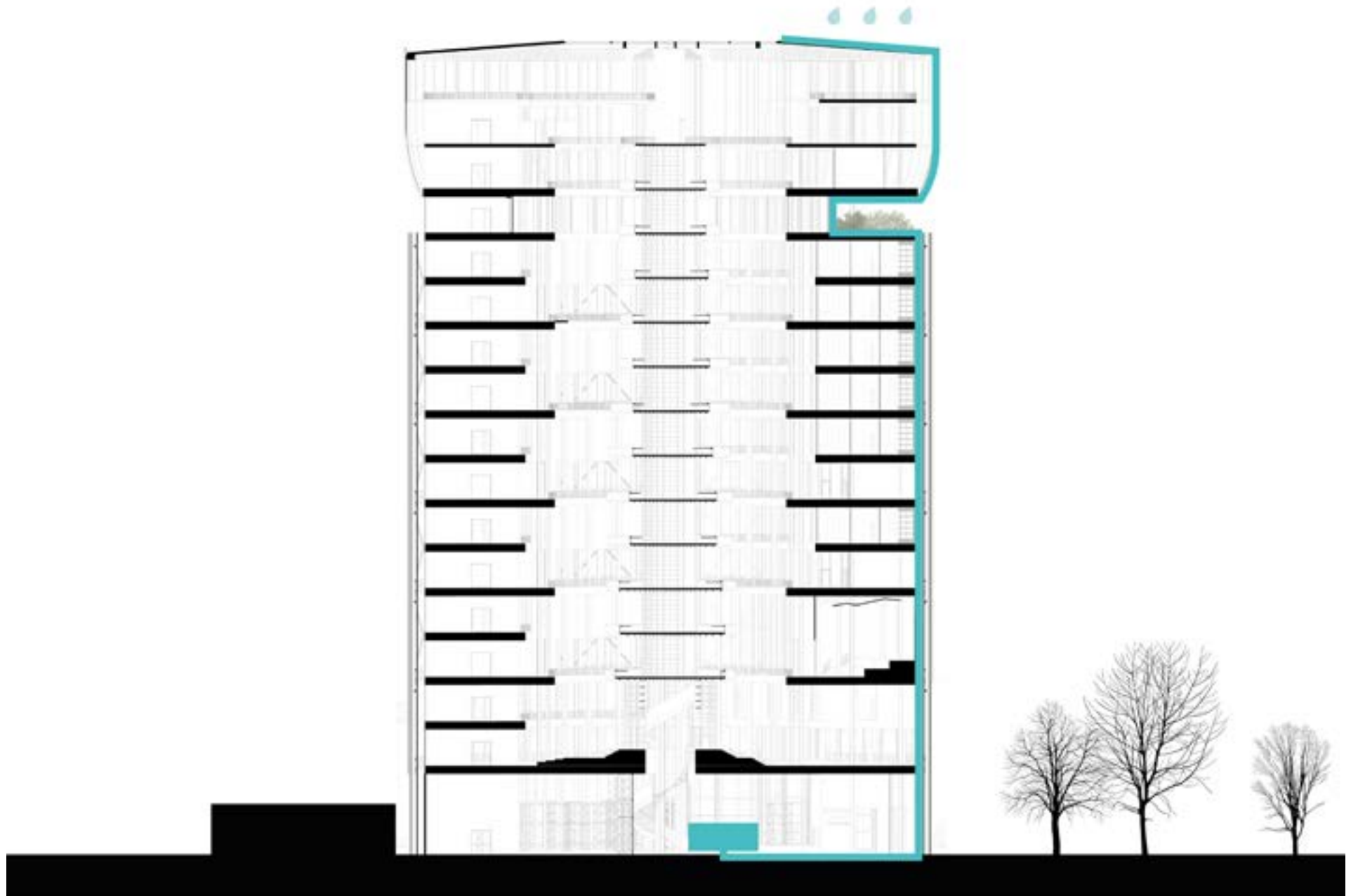

climate
SUMMER

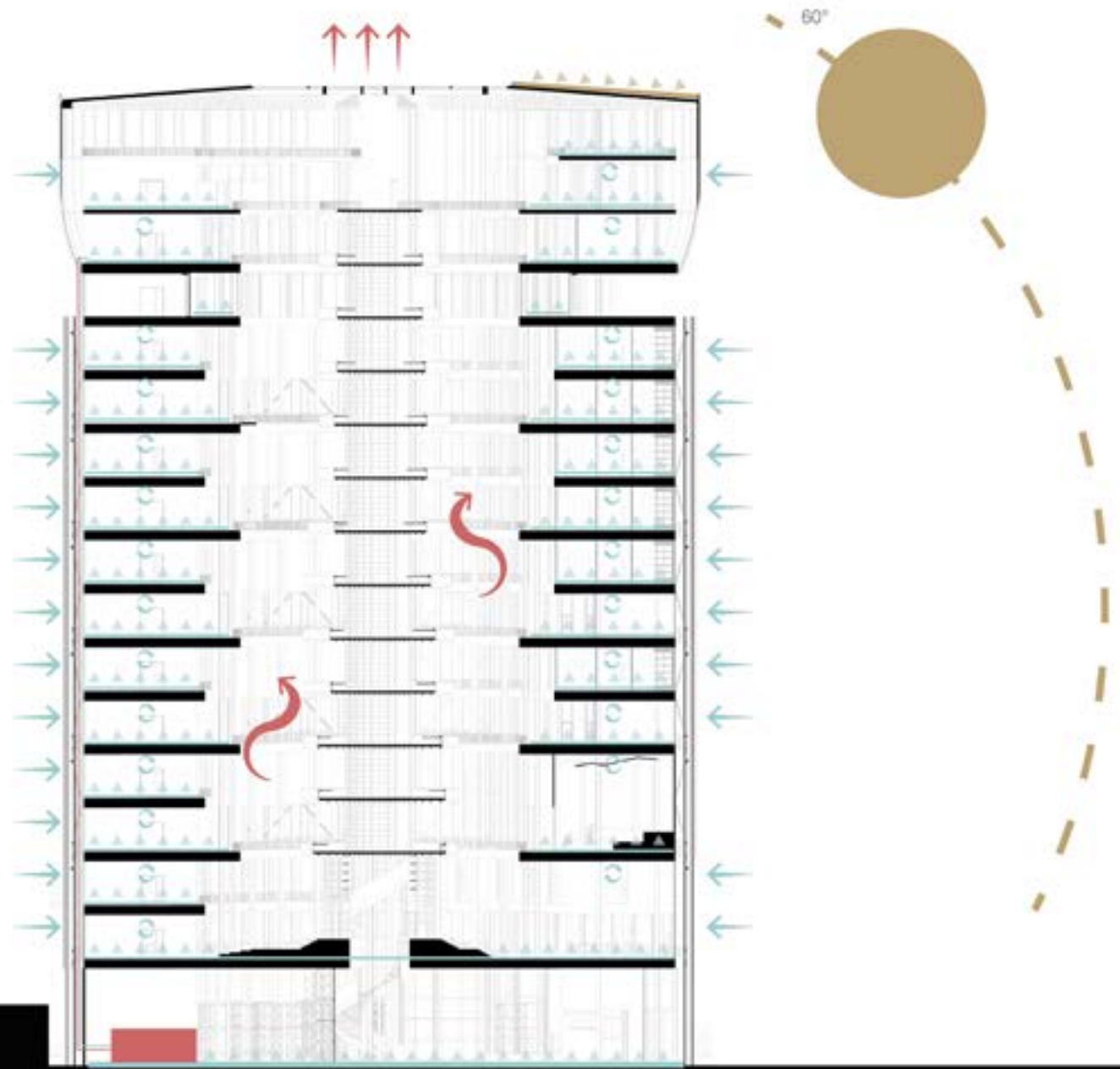

climate
WINTER

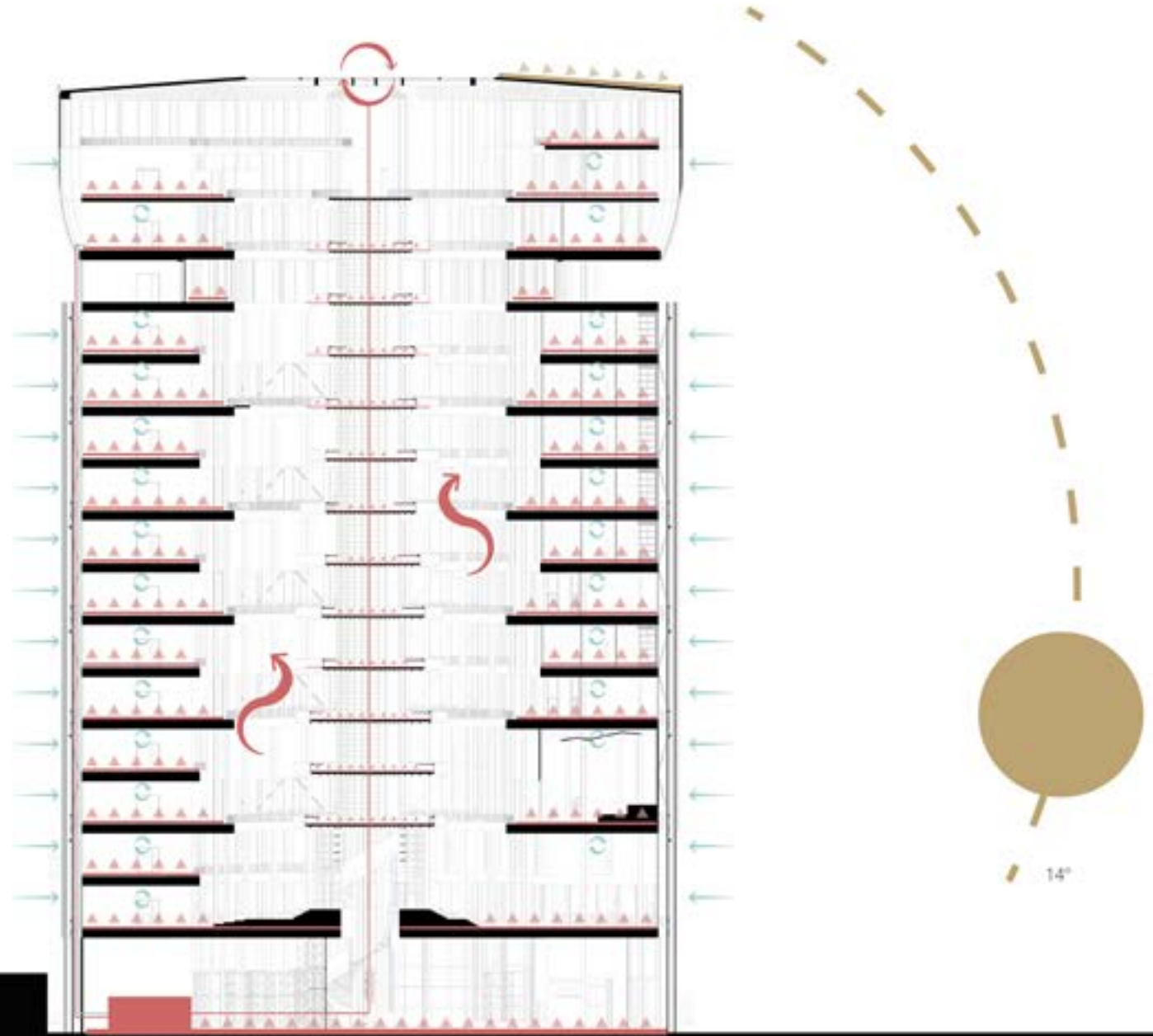

- 01 INTRODUCTION
- 02 LIBRARY
- 03 DESIGN BRIEF
- 04 DESIGN CONCEPT
- 05 DESIGN IMPLEMENTATION
- 06 CONCLUSION**

conclusion

RESEARCH QUESTION



Can libraries become future-proof promoters of sharing and creating knowledge through the curation of materials and adaptive reuse strategies?





THE CAMPUS
EUREF



THANK YOU.

MATERIAL VAULT

Library of Materials

Kalina Matova

07/11/2024