

Design of the navigation and discharge channel in the tidal lake of the Delta21 project

A design and morphological modelling study

Quintes van Horick

Design of the navigation and discharge channel in the tidal lake of the Delta21 project

A design and morphological modelling study

By

Q.R.B. (Quintes) van Horick

student number: 4436210

Master Thesis

Delft University of Technology
January 22, 2023

Thesis committee:	Dr. ir. M.A. (Matthieu) de Schipper	<i>Chairman</i>	TU Delft
	Dr. ing. M. Z. (Mark) Voorendt	<i>First supervisor</i>	TU Delft
	Ir. M. (Martijn) Onderwater	<i>Supervisor</i>	TU Delft & Arcadis
	Ir. D. (Daan) Kampherbeek	<i>Supervisor</i>	Van Oord

Cover: Impression of Delta21 project. Designed by Esmee van Eeden.



Acknowledgement

This thesis concludes my Master of Science program in Hydraulic Engineering at Delft University of Technology. This research was conducted as part of the Delta21 initiative in collaboration with Van Oord and Delft University of Technology. I am very grateful for the opportunity to work on such an innovative and challenging project. I really enjoyed working with my supervisors and have learned very much from this experience.

This research would not have been possible without the support, time and expertise of my graduation committee. I would like to thank Matthieu de Schipper for allowing me to graduate on this research topic and for your fruitful discussions and comments during our progress meetings. Thank you to Mark Voorendt for introducing me to this topic and being my weekly supervisor. I enjoyed our meetings and I thank you for helping me by adding structure and clarity in my report and especially through the designing process. Thank you to Martijn Onderwater for being my second weekly supervisor. Our weekly meetings really helped me through the process of the research and kept me on the right track. Our discussions have mainly formed the foundation and guidelines for this thesis, which I am thankful for. Thank you to Daan Kampherbeek for being my supervisor at Van Oord and to introduce me to the company. I enjoyed my weekly days at the office and thank you for the time you invested in me and my thesis. Your feedback and questions on topics really challenged me to improve my work.

Special thanks to Huub Lavooij and Leen Berke for initiating Delta21 and to allow for me and fellow students to perform research related to the Delta21 project. I am also very grateful for introducing me to Van Oord and providing the position of graduate intern. The Delta21 project still has a long way to go with many challenges, but I believe that the concept is a great solution for Dutch flood protection and I am honoured to have made a contribution to that.

I would also like to thank my fellow students and friends with whom I have spent a lot of time while working on my thesis. I cherish these days of studying in a group and being able to share experiences during graduation. Special thanks to Bob Verschoor, who helped me and thought along with me at several research decisions.

Last but certainly not least, I would like to thank my family and friends for supporting me in the process and their interest in my thesis. A sincere thank you to my girlfriend Sterre. She has supported me every day during my thesis. She has helped and advised me in many research decisions and stood by me throughout the process. Thank you so much!

*Quintes van Horick
Delft, January 22, 2023*

Summary

The awareness of climate change has grown worldwide in the past years. Possible consequences of climate change are sea level rise, heavier storms and high river discharges, but also prolonged drought. For a country such as the Netherlands, these water level variations, high discharges and droughts could have a great impact. Therefore, solutions of flood protection and water management are required to cope with these possible consequences.

The Delta21 project proposes a solution for flood protection of the Southwest delta in the Netherlands, while contributing to energy storage and nature preservation. The Delta21 project is a dam structure located in the Haringvliet mouth and, when constructed, results in a large change of the environment in the Haringvliet mouth. The remaining area of the Haringvliet mouth becomes the tidal lake. The important functions of the tidal lake are to be navigable and to have the capacity for extreme discharges to flow through the lake, without posing threats to safety. The functions are fulfilled by a channel through the tidal lake. The current channel (Slijkgat) requires highly frequent maintenance to allow for navigability and contains bottlenecks to meet the discharge capacity function. Hence, the objective of this research is to determine a suitable channel configuration in the tidal lake of Delta21, considering navigability and discharge capacity.

A suitable channel configuration is determined by designing a channel, accompanied by a morphological modelling study. The functional requirements and criteria for the design are defined based on the stakeholders interests. The requirements and the expected hydrodynamic and morphodynamic conditions in the tidal lake have resulted in three channel concepts that are considered for the design process. One of the concepts is the current bathymetry of the Slijkgat. The other concepts are Channel Concept 1 and Channel Concept 2, which are the same in cross-sectional area but different in orientation and location. The orientation of Channel Concept 1 is a small adjustment from the current Slijkgat, where the bend is slightly straightened. Channel Concept 2 is an almost straight channel and has the shortest length through the tidal lake.

The numerical modelling study is applied on the design in order to determine the morphological response of the system to the concepts and indicate the influence on the navigability, discharge capacity and maintainability. A Delft3D-FLOW model is applied for two simulation periods; normal conditions of one year of morphological modelling and extreme conditions for one week. The normative hydrodynamic drivers for normal conditions are the tide and the river discharge and for the extreme conditions only (extreme) river discharge.

The hydrodynamic and morphological results from the modelling study are processed in order to evaluate the three concepts in a qualitative and quantitative manner. The evaluation criteria are based on navigability, maintenance and nature preservation. Based on the results, Channel Concept 2 is most suitable in terms of navigability and maintenance with respect to the other concepts. Therefore, evaluation has led to the selection of Channel Concept 2 as the most suitable channel configuration. Additionally, an optimisation is proposed for the selected channel concept in order to improve the fulfilment of the maintainability criteria. A dam around the north western end of the channel is proposed in order to decrease the sedimentation volume in the channel. Modelling computations including the dam resulted in a significant decrease of sedimentation in the channel. Hence, the dam is an improvement to the selected channel concept.

Concluding, Channel Concept 2 is considered the most suitable channel configuration in the tidal lake with respect to the other concepts. Implementing the dam in the tidal lake further improves the channel concept in terms of maintainability and navigability.

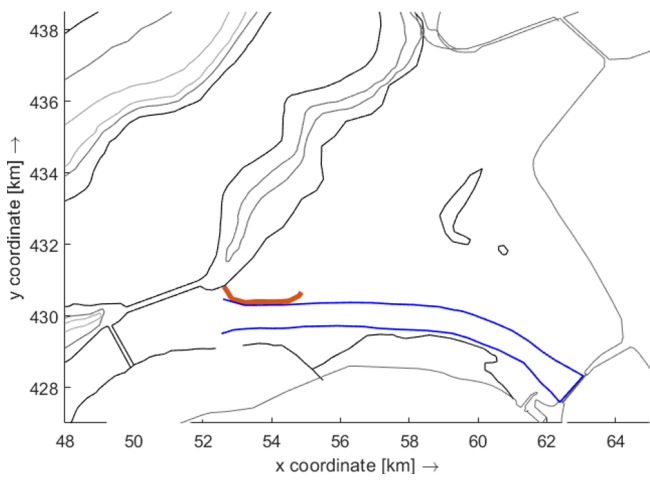

Channel Concept 2, including the dam. Left: a schematic representation. Right: implemented in the design by Van Eeden (2021).

Contents

Acknowledgement	i
Summary	ii
1 Introduction	1
1.1 Research motivation	1
1.2 Problem Analysis	2
1.3 Objective and research question	9
1.4 Approach and thesis outline	9
2 System analysis channel design	11
2.1 Stakeholder analysis	11
2.2 Functional analysis	14
2.3 Requirements	15
2.4 Evaluation criteria	16
3 Processes analysis of research area	18
3.1 Interventions in the Voordelta	18
3.2 Hydrodynamics	20
3.3 Morphodynamics	26
3.4 Concluding remarks	28
4 Channel design concepts	29
4.1 Starting points for the design	29
4.2 Initial Bathymetry	31
4.3 Channel Concept 1	32
4.4 Channel Concept 2	32
5 Morphological model setup	33
5.1 Introduction	33
5.2 Modelling grid	33
5.3 Bed schematisation	35
5.4 Boundary conditions	38
5.5 Calibration and validation	42
5.6 Model conditions and parameters	43
5.7 Model scenarios	46
6 Model results	48
6.1 Hydrodynamic results	48
6.2 Morphological results	55
6.3 Concluding remarks	62
7 Evaluation and design selection	63
7.1 Evaluation	63
7.2 Design selection	65
7.3 Concluding remarks	65
8 Optimisation of channel design	66
8.1 Intervention	66
8.2 Optimisation results	67
8.3 Concluding remarks	72

9 Discussion	74
9.1 Model Limitations	74
9.2 Design Limitations	75
10 Conclusions and Recommendations	77
10.1 Conclusions	77
10.2 Recommendations	79
References	84
A Argumentation of the requirements	85
A.1 Navigability	85
A.2 Discharge capacity	88
B Wind wave analysis	89
C Validation results	91
D Discharge Probability of occurrence	93
E Simulation results	95
E.1 Flow patterns	95
E.2 Longitudinal and cross velocities	98
E.3 Sediment transport patterns	101
F Evaluation components expansion	104
F.1 Evaluation scoring characteristics	104
F.2 Scoring argumentation	106

1 Introduction

1.1 Research motivation

The awareness of climate change, and the possible consequences over the coming decades, has increased worldwide in the past years. In terms of sea level rise, most recent studies by the Intergovernmental Panel on Climate Change (IPCC) have resulted in the prediction of a significant mean global sea level rise by the year 2100 when assuming a medium scenario of greenhouse gasses emissions (IPCC, 2021). For worse scenarios, the sea level rise will be significantly higher. Also, for the Dutch coasts a similar and more accurate sea level rise has been predicted by the Dutch meteorological institute (KNMI, 2021). However, there is still uncertainty when predicting the consequence of sea level rise in 2100, which is mainly due to dependence on the rate of emissions. To reach a decrease in emissions, global restrictions such as the Paris agreement (2015) have been set up. These restrictions tend to guide to better scenarios by setting restrictions to maximum allowable global temperature increase. Besides sea level rise, climate change induces an increase of extreme events, such as heavier storms, prolonged droughts and more precipitation. These consequences may result in high river discharges and higher wave setup by wind. To account for possible scenarios of sea level rise, high river discharges and larger wave setup, measures should be considered to protect the hinterlands of lowlands and deltas. These measures are especially necessary for countries such as the Netherlands.

For the Netherlands severe measures are required, since 26% of the land is below sea level and 60% is sensitive to flooding. From an economical point of view, 70% of the gross domestic product is earned in potential flooded areas in the Netherlands (LenW, 2015). Several measures throughout the country have already been initiated. One potential measure is the initiative of the Delta21 project. Delta21 is a concept of a dammed stretch of dunes between Maasvlakte 2 and the island Goeree Overflakkee. The main purpose of the project is to secure flood protection, energy transition and nature preservation (Berke & Lavooij, 2021). The most recent design, which is assumed for this research, is shown in Figure 1.1. This report studies the morphological response of the to be developed connection between the Haringvlietdam and the sea.



Figure 1.1: Design Delta21 by Landscape Architect Van Eeden (2021).

1.2 Problem Analysis

This section elaborates on the components and the purposes of Delta21 and the surrounding area that is affected after construction. In Section 1.2.1, the motivation for Delta21 will be discussed, namely the expected consequences of climate change. Section 1.2.2 contains elaborate information about Delta21, assuming the three main purposes of the project. Section 1.2.3 is focused on the area of interest for this research proposal, the Haringvliet mouth. It contains the most recent interventions in the area and the possible morphological consequences after construction of Delta21.

1.2.1 Climate change predictions

As mentioned in the previous section, the possible consequences of climate change need to be taken into account when considering flood protection. In terms of sea level rise, the most recent reported mean global sea level rise is set to 3.7 mm per year (IPCC, 2021). Additional prediction studies by the IPCC 2021 have resulted in a global mean sea level rise of 0.44-0.76 meters by 2100, when assuming the so-called intermediate scenario SSP2-4.5 of greenhouse gasses emissions (IPCC, 2021). To give a clear perception; the most favourable scenario (SSP2-1.9) results in a sea level rise of 0.28–0.55 meters and the worst scenario (SSP-8.5) in a rise of 0.98-1.88 meters. Notice that the range of dispersion is quite large, especially for worse scenarios. This means that there is still uncertainty regarding these predictions. Again, for the Netherlands, where the area of interest for this research is situated, more local predictions were made by the KNMI. Considering the same studie and emission scenarios as the IPCC, the SSP-4.5 scenario results in a sea level rise of 0.39-0.94 meters by 2100 (KNMI, 2021). This study was performed in 2021 and was more of an addition to the IPCC 2021 report. In 2014, the KNMI performed a much more elaborate study on the prediction of consequences of climate change (KNMI, 2014). It predicted that by the year 2100, a sea level rise of 0.25-1.0 meters would occur. This prediction shows more variation compared to the studies performed in 2021, but the results are within the same bandwidth.

Another consequence of climate change that needs to be considered is the increase of extreme events for river discharges. For instance, in the summer of 2021, a large amount of rain fell in the south of the Netherlands, Belgium and Germany, resulting in the largest floods ever measured in the area. Consequently, this led to large river discharges in the Meuse and other branches. These large amounts of precipitation normally occurs in more southern and warmer areas. Due to global warming, extreme events that lead to high discharges are likely to happen more often in the future in this area (ENW, 2021). Besides more concentrated precipitation intervals, there will also be longer periods of drought, which poses problems for flora and fauna, as well as for short term fresh water supply.

Delta21 is a measure that copes with consequences such as sea level rise and high river discharges. Apart from the uncertainty in the predictions, it is still likely that significant increases of sea level rise and large fluctuations in river discharges will occur in the near future. This makes Delta21 a valid measure to consider and explore. This research is focused on the initial morphological response, in terms of a few years, when considering the construction of Delta21. Therefore, the consequences of climate change are not considered significant yet for this research.

1.2.2 Delta21 project

As mentioned in previous sections, the Delta21 project is considered for this research. The main purposes of Delta21 are to secure flood protection, contribute to the energy transition and to preserve nature in the area. This section explains the project more in detail, both the components and system as well as an elaboration on the three purposes.

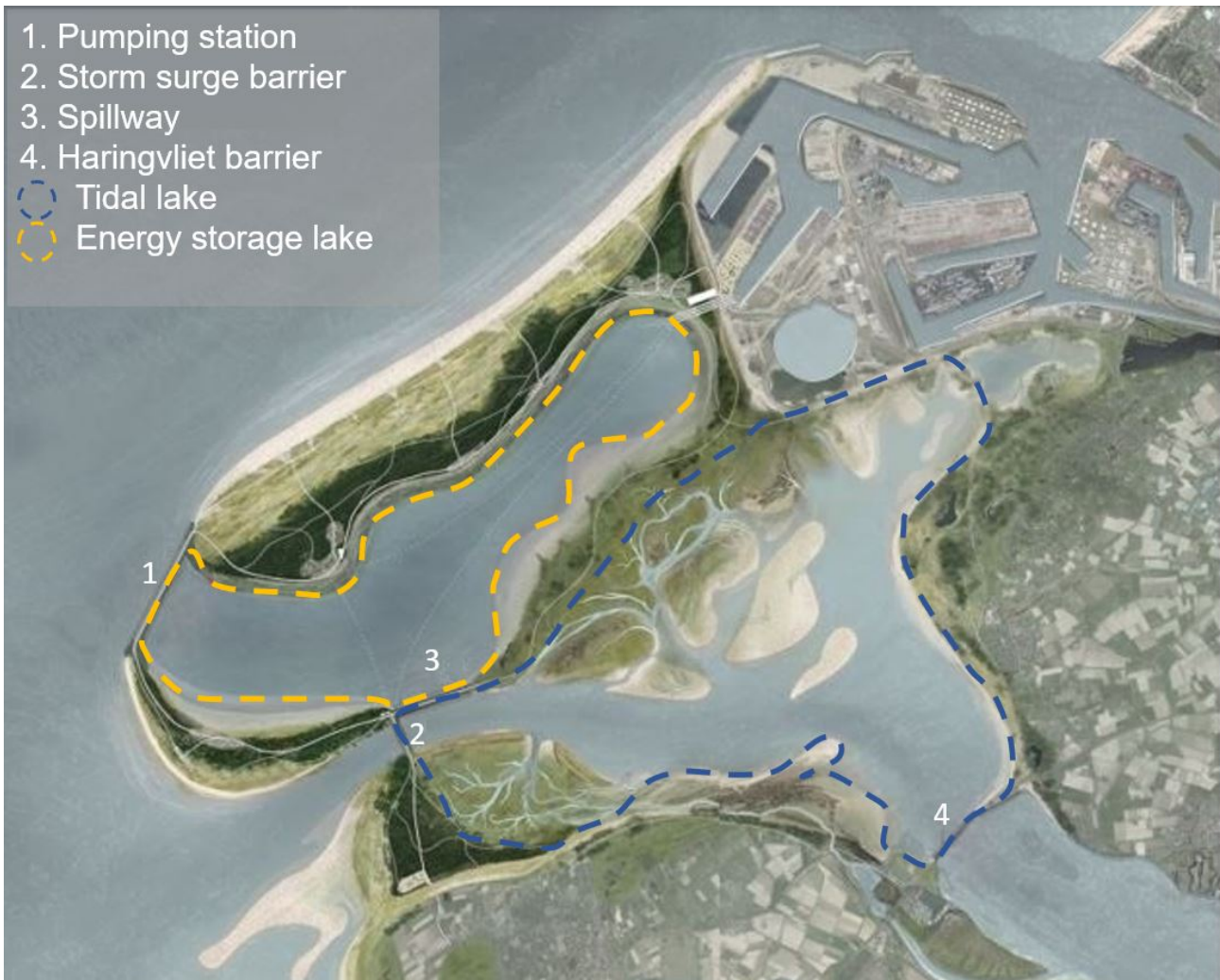

Figure 1.2: Layout Delta21 by Landscape Architect Esmée van Eeden (Van Eeden, 2021), including indicated components in the area.

Delta21 components

Figure 1.2 contains several components that are important to clarify for this research. The two marked areas, indicated by the dotted lines, are the tidal lake and the energy storage lake. The tidal lake will be formed in the current Haringvliet mouth and will thus become a sheltered area from ocean waves due to the construction of Delta21. The tidal lake is influenced by the tide from the sea and the upstream river discharge, following the Kierbesluit (Noordhuis, 2017). So, the tidal lake is more characterised by an estuary, but for consistency it will remain to be called the tidal lake. The energy storage lake will be placed between the dune stretch and the tidal lake, and will function as a storage for high discharges from the upstream river branches. The dune stretch is intermittent by a pumping station (1), which is able to pump the discharged water from the energy storage lake to the sea and vice versa by using turbines to generate energy. To clarify this mechanism, a cross-sectional schematisation for normal conditions is provided in Figure 1.3. In case of an open Haringvliet barrier, the discharged water by the river branches will first enter the tidal lake through the sluices of the Haringvliet barrier (4). For

sufficiently large discharges, the water will enter the energy storage lake over a spillway (3), which is situated between the marked areas. The final component of Delta21 is the storm surge barrier (2), which is a hard structure for flood protection and the only gateway between the tidal lake and the sea. The storm surge barrier is placed at this location to enable navigability and exchange of water and sediment (Berke et al., 2018).

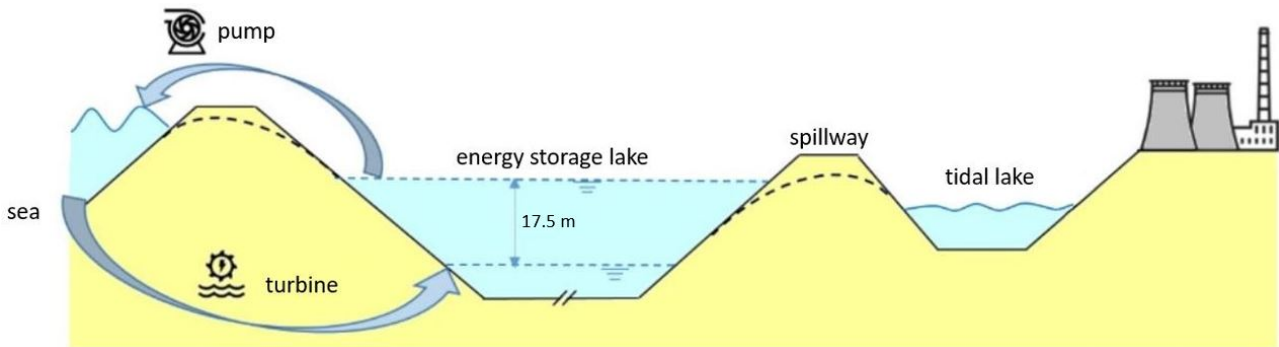

Figure 1.3: Cross-sectional schematisation of the operational mechanism of the energy storage lake for normal conditions (Timmermans & Voorendt, 2019).

For this research, the focus is on the impact on the morphology of the tidal lake in the Haringvliet mouth, after construction of Delta21. The exchange of water and sediment through the storm surge barrier and the peak-discharges through the Haringvliet barrier will be of importance. Especially the impact of the morphological changes on the navigation channel will be considered in terms of erosion and sedimentation.

Flood protection

The most important objective of the Delta21 project is to secure flood protection. As mentioned before in Section 1.1, a dune stretch will be formed by placement of a mega-nourishment at the outer seaside of the energy storage lake. The dune stretch is supposed to guarantee flood protection against wave conditions and the accompanying sea level rise, by applying a height that reaches up to NAP +10 m at the top of the dunes. Furthermore, the storm surge barrier at the south of the energy storage lake protects against extreme conditions from the sea by closing of the sluice gates. Protection against flooding of the upstream rivers is considered as well. Delta21 is designed to cope with high discharges, accompanied by high water levels. The pumps of the energy storage lake are designed to pump a maximum discharge of 10,000 m³/s to the sea (Berke et al., 2017). This extreme condition of pumping a high discharge within a short period of time is mostly accompanied by the sluice gates of the storm surge barrier being closed and an open spillway. This procedure is shown in Figure 1.4, where water from the tidal lake enters the energy storage lake over the spillway, which has a capacity of 10,000 m³/s too. The energy storage lake is required to be emptied before the high discharge enters, to make use of its full potential. The minimum water level in the energy storage lake that is reached by the pumps is at NAP -22.5 m and the maximum is set to NAP -5 m. Hence, a head difference of 17.5 m in the energy storage lake can be pumped directly into the sea. The threshold for using the storage lake is when the water level at the upstream city of Dordrecht reaches NAP +2.5 m (Berke et al., 2018).

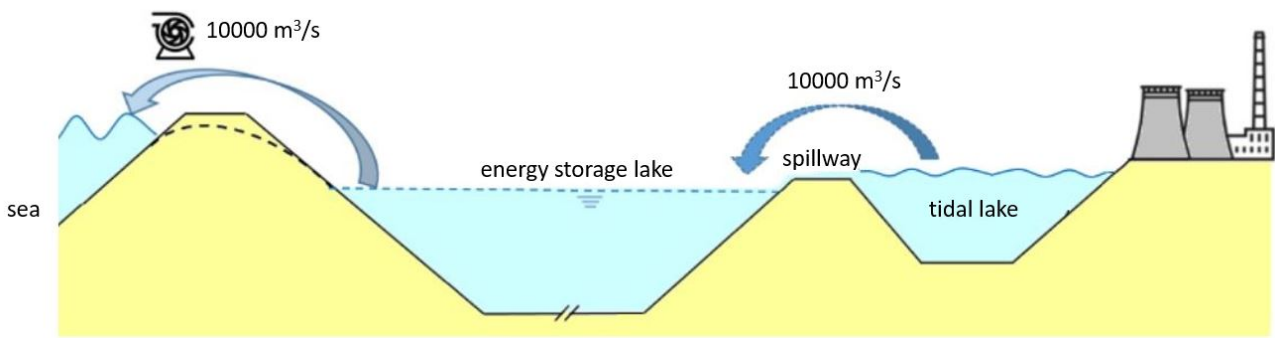

Figure 1.4: Cross-sectional schematisation of the operational mechanism of the energy storage lake for extreme conditions (Timmermans & Voorendt, 2019).

Stabilisation of sustainable energy supply

The pumping station should be able to pump water from the energy storage lake to the sea for extreme conditions. The pumping requires energy, which is desirable to be generated within the Delta21 project to reduce energy costs and stabilise energy use. There are plans to install wind turbines and solar panels on and around the energy storage lake to generate energy. Additionally, the pump system is equipped with the option to let seawater flow into the energy storage lake, where the pumps function as turbines, which then generate energy. This gives the opportunity to supply energy when there is a high demand and energy prices are high, and pump to the sea when the prices are low. For non-extreme conditions the pump system can be applied to generate a surplus of energy and store it for times of higher demand. The time to fully fill or empty the energy storage lake is 12 hours. So, within 24 hours of consuming and producing energy, a stable energy situation can be reached. The Delta21 project gives the opportunity to act as a renewable energy source by generating wind and solar energy, as well as energy generated by turbines.

Nature preserve

For the Delta21 project, nature preservation is a necessity. The area of interest for Delta21, the Voordelta, is part of the Natura2000 network and is associated with accompanying regulations (Natura2000, 2018). These regulations focus on nature preservation of the area and disturbances for the flora and fauna. By realising the Delta21 project, disturbances are inevitable. These disturbances and changes of the area will require a nature compensation when following the Natura2000 regulations. However, especially with the current design, Delta21 will be a so called "Building with nature" project. This creates new features of nature and thus new areas for nature to thrive. Additionally, to connect the salt water area of the sea and the Haringvliet, a fish migration river will be constructed to allow the intrusion of fish back in the Haringvliet. The Haringvliet barrier will on the other hand open and close following the Kierbesluit and will not allow significant salt intrusion into the Haringvliet.

Delta21 operational scenarios

The components of the Delta21 project collaborate to the full system of securing the three purposes in daily and extreme conditions. Figure 1.5 provides an overview of the relevant scenarios for extreme conditions (Berke et al., 2018). There are three main occurring scenarios that require the Delta21 system to deviate from the daily conditions. This includes the whole southern delta components, so also the Europoortkering and the water level at the city of Dordrecht. For clarification; the Europoortkering represents the barriers that can close off the Nieuwe Waterweg, so the combination of the Maeslantkering and the Hartelkering. The occurring scenarios are respectively a high discharge ($> 9000 \text{ m}^3/\text{s}$) through the Nieuwe waterweg and the Haringvliet combined, a high discharge ($> 5000 \text{ m}^3/\text{s}$) through the combined Nieuwe Waterweg and Haringvliet and an expected storm surge ($> 1.5 \text{ m}$) at Hoek van Holland (HvH). Note, that there is one difference with respect to the current Delta21 flood protection report. The closing of the storm surge barrier for a high discharge ($> 9000 \text{ m}^3/\text{s}$), will be at low water (LW) instead of high water (HW). It seems more convenient to close the storm surge barrier at low

water, because there will be more storage capacity in the tidal lake. Also, there will be less water to be pumped to the sea, which requires less energy and time for pumping.

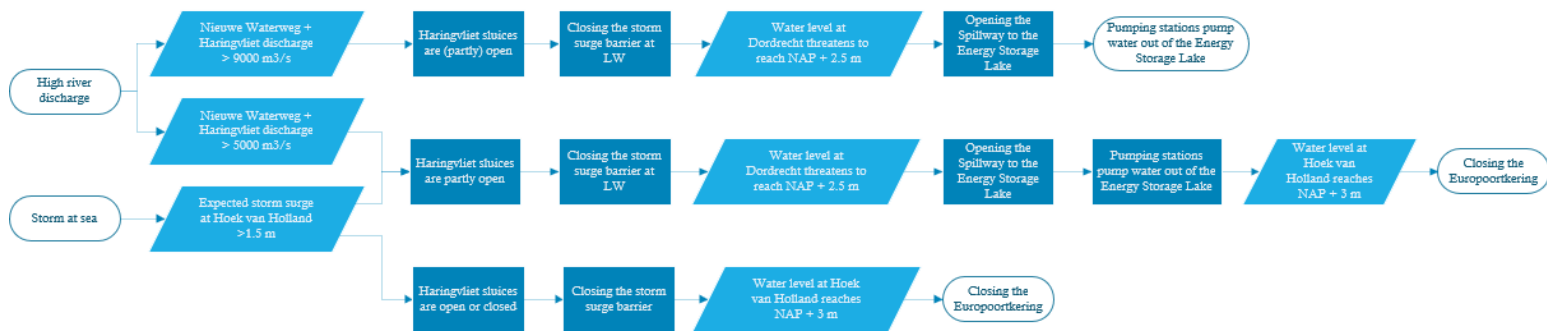

Figure 1.5: Occurring scenarios and corresponding operational scenarios of the Delta21 project (Verschoor, 2023).

Additionally, to indicate the state of the different components during the scenarios, Table 1.1 is provided. This table together with the flow chart, is the basis of the Delta21 system and will be referred to in further sections if necessary. To visualise the state of each structure from the table, Figure 1.6 is provided for clarification.

Table 1.1: State of Delta21 components for different scenarios (Adjusted from: (Verschoor, 2023)).

Scenarios	Haringvliet sluices*	Storm surge barrier	Spillway	Pumping station	Europoortkering
Daily conditions	Open or Closed	Open	Closed	No Pumping	Open
1.1 Discharge > 9000 m ³ /s	Open	Closed	Closed	No Pumping	Open
1.2 Discharge > 9000 m ³ /s WL at Dordrecht NAP +2.5 m	Open	Closed	Open	Pumping	Open
2.1 Discharge > 5000 m ³ /s Expected storm surge at HvH > 1.5 m	Open	Closed	Closed	No Pumping	Open
2.2 Discharge > 5000 m ³ /s Storm surge at HvH > 1.5 m WL at Dordrecht NAP + 2.5 m	Open	Closed	Open	Pumping	Open
2.3 Discharge > 5000 m ³ /s Storm surge at HvH > 1.5 m WL at Dordrecht NAP + 2.5 m WL at HvH NAP + 3.0 m	Open	Closed	Open	Pumping	Closed
3.1 Storm surge at HvH > 1.5 m	Open or Closed	Closed	Closed	No Pumping	Open
3.2 Storm surge at HvH > 1.5 m WL at HvH NAP + 3.0 m	Open or Closed	Closed	Closed	No Pumping	Closed

* The rate of opening and closing of the Haringvliet barrier depends on the Kierbesluit, which contains a more detailed closing procedure for occurring discharges.

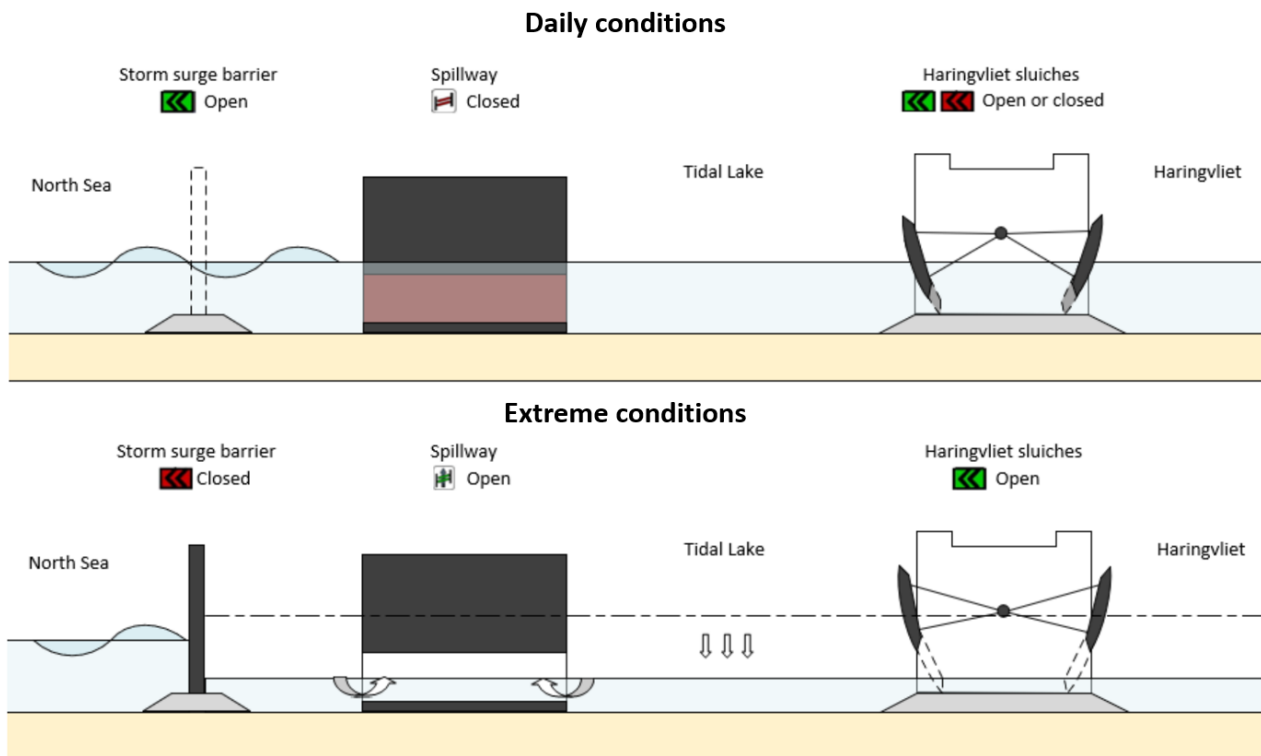

Figure 1.6: Cross-sectional schematisation of the state of the structures (pumping station excluded) of Delta21 for daily conditions and extreme conditions (Verschoor, 2023).

1.2.3 The Haringvliet mouth morphology

This research is focused on the morphology of the Haringvliet mouth. Therefore, this section is meant to elaborate on the area in terms of morphological changes throughout the years and the accompanying consequences. Furthermore, possible morphological consequences when introducing Delta21 in the area are stated.

The morphology of the Haringvliet mouth has changed throughout the years. The closing of the Haringvliet by the Haringvliet barrier (early 1960s) has been the largest change, together with the extension of the port of Rotterdam by construction of the Europoort (1964–1966), Maasvlakte 1 (1964–1976), Slufterdam (1986–1987) and Maasvlakte 2 (2008–2013), respectively. The closure of the Haringvliet has resulted in a reduction of the tidal volume of the inlet. Consequently, this resulted in a more wave dominated regime where the ebb-tidal delta eroded and sedimentation occurred more landward. The effect of sedimentation has been enhanced by the extension of the port of Rotterdam, where sediment is trapped at the southern side and thus not transported further north (Van Holland, G., 1997; de Vries, 2007; Elias et al., 2016; Colina Alonso, 2018). The morphological developments of the inlets since the closures, are presented in Figure 1.7, with the bathymetry of 1964 and 2009 of the Haringvliet mouth. Due to closing, also the channels towards the Haringvliet river were filled by sedimentation. Only the Slijkgat has remained navigable over the years.

Introducing the Delta21 project into the area will probably have a larger impact than the previous interventions. The design by Esmée van Eeden (2021) is located in the current ebb-tidal delta of the Haringvliet inlet and will function as a closure of the Haringvliet mouth. In between the energy storage lake and the Haringvliet barrier, the tidal lake will form, which is hydrodynamically influenced by the tide, local wind waves, incoming ocean waves through the storm surge barrier and inflow through the Haringvliet sluices. Due to the nearly full closure, the current sedimentation by the wave dominant sediment transport will be shifted to a tide dominant system in the newly formed lake. In this system

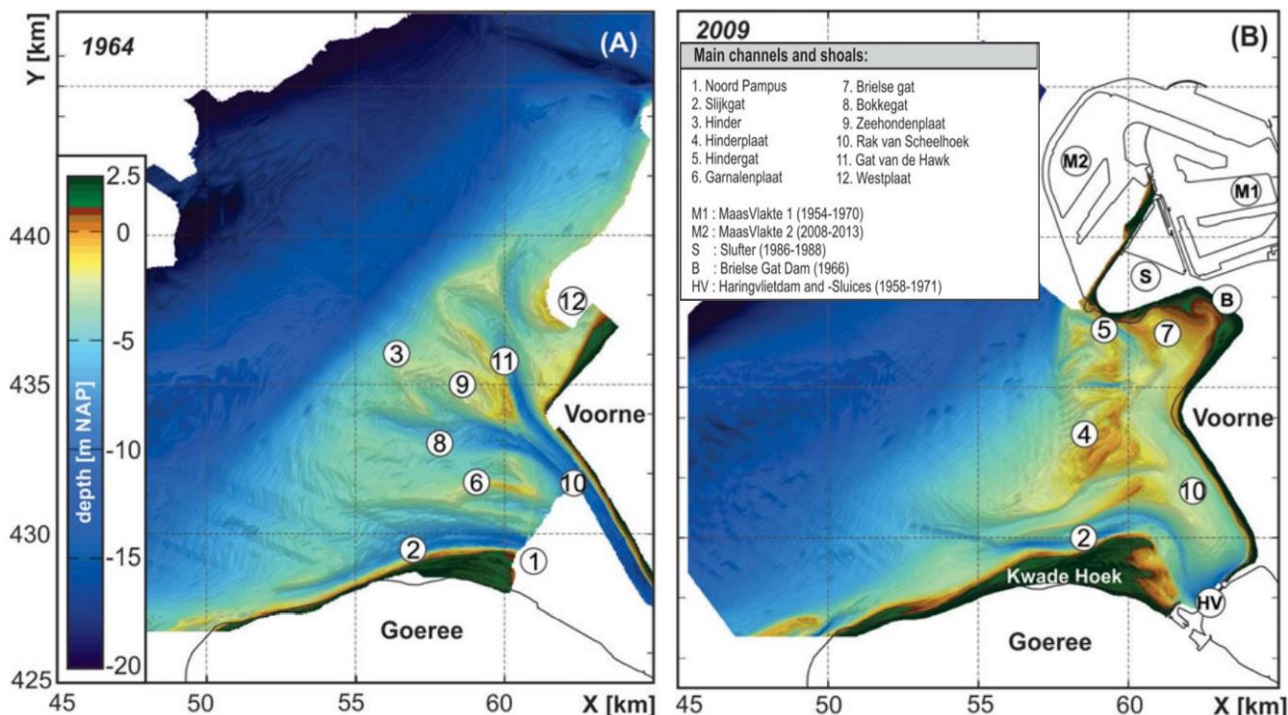

Figure 1.7: Bathymetry of the Haringvliet ebb-tidal delta before (1964) and after the damming of the estuaries (1976–2009) (Elias et al., 2016).

only tidal propagation in combination with locally generated waves access the lake through the storm surge barrier. The inlet to the tidal lake could resemble the properties of a tidal inlet of an estuary. Considering this assumption, due to Delta21, a reduction of the tidal prism and channel volume could then results in sediment import from the newly formed outer delta (Bosboom & Stive, 2021). On the other hand, river discharges from the Haringvliet will still enter the area, which may lead to erosion in the channel due to high discharges.

Considering the morphology in the Haringvliet mouth, the construction of Delta21 will probably result in a shift of a wave dominant to a tide dominant system. This means that the current sediment transport will shift significantly. This has already partly been confirmed by a previous morphological study (Zaldivar Piña, 2020), assuming a different Delta21 design. Furthermore, the navigation channel, which connects the Haringvliet barrier with the sea and energy storage lake, should remain navigable and cope with high river discharges. The latter requirement holds for the entire tidal lake, where the channel has a large contribution to the discharge capacity. The potential rate of erosion and sedimentation in and around the channel, and the relative rates between the hydraulic components is uncertain, nor to what extent certain solutions are necessary. Possible solutions might be dredging operations.

1.3 Objective and research question

As stated in Section 1.2, the impact of Delta21 on the Haringvliet mouth will be significant. The morphological consequences and boundary conditions in the tidal lake for this Delta21 design are still under assumption. Considering the navigation and discharge channel, an extension of the current Slijkgat is required to connect the Haringvliet barrier and the spillway. This enables upstream discharges to flow into the energy storage lake within a short period of time. Besides the required discharge capacity, navigability should remain as a function of the channel. The morphological changes that may occur after construction of Delta21 will have an effect on the fulfilment of the channel requirements, which may lead to the necessity of dredging maintenance operations. Again, the magnitude of these morphological consequences are not known yet. Therefore, the objective is to design the navigation and discharge channel in the tidal lake of Delta21 and research the morphological response for both a long and short period of time, 1 year and a few day, respectively.

The above mentioned objective and additional information result in the following main research question:

What is a suitable channel configuration through the tidal lake of Delta21, considering navigation and discharge capacity?

The research question can be divided into several sub-questions, which are formulated below.

1. Which design requirements are applicable for the design of the navigation and discharge channel?
2. What is the qualitative morphological development in the tidal lake of Delta21 and what hydraulic components contribute to this development?
3. How will the morphological response influence the navigability, discharge capacity and maintainability of the channel concepts?
4. What is the most suitable channel concept?
5. How can the preferred channel concept be optimised?

1.4 Approach and thesis outline

To reach the objective and to answer the research questions described in Section 1.3, an approach with a report outline is set up, which is distinguished in the following stages below.

1. System Analysis

The first stage for this research is to setup the first steps in designing the area that is formed between the Haringvliet barrier and Delta21; the tidal lake. In particular it contains the first steps for designing a channel between the Haringvliet barrier and the spillway of Delta21. Chapter 2 contains the system analysis for the design. First a stakeholder analysis is performed, which results in an overview of the stakeholders and their interests and involvement in the design. Next, the functional requirements are setup, which follow from the stakeholder analysis and functions. This too leads to the answering of the first research sub-question. Additionally, criteria are posed, which in a later stage are used as an evaluation tool for the conceptual designs.

2. Process Analysis

The process analysis (Chapter 3) first considers the development of the Haringvliet mouth over the past decades is, including the human interventions. This description will help in understanding what caused the (morphological) changes in the area. Next, the hydrodynamic and morphodynamic behaviour of the area is described. This will help to understand the area of interest and

to find out what hydraulic processes are to be considered for the morphodynamics when Delta21 is constructed. This stage, contributes to a process analysis of the tidal lake, which results in the setup of boundary conditions and the answering of the second research sub-question.

3. Creation of design concepts

The boundary conditions of the tidal lake, together with the system analysis components of the first stage, are the basis of a conceptual design. Chapter 4 defines channel concepts which fit the requirements. These concepts are of channels with a certain orientation and cross-sectional area. The concepts will be tested in the morphological modelling study.

4. Morphological model setup

To obtain the morphological development of the concepts of the channel, calculations are performed with a morphological model. In order to obtain valid results of the morphological response, a developed process based Delft3D model is used and adjusted to comply with the boundary conditions of this research. This stage indicates the model setup, which helps to understand and verify the several components of the model, such as the grid, the bed composition and the hydraulic boundary conditions. Furthermore, adjustments of certain boundary conditions of the former model will be made in order to resemble the design and conditions of this research. The model setup is described in Chapter 5.

5. Morphological modelling

The morphological response of the channel concepts are to be determined for normal long-term conditions and extreme short-term conditions in the order of years and days, respectively. The morphological changes for these two conditions will be modelled for several model scenarios per concept. These scenarios contain calculations for every normative hydraulic forcing, including tide and discharge. After validation of these results, a combined morphological effect is modelled for normal and extreme conditions. For normal conditions, a first and second year are modelled. This in order to obtain an indication of a long-term morphological development.

6. Processing results

With the model results, an overview of the morphological changes is provided. This stage is meant to translate the results of the model to a clear and relevant representation of the morphological response and to allow for evaluation of the concepts in the next step. The model results are discussed in Chapter 6 and allows to answer the third research sub-question.

7. Evaluation

In Chapter 7, the design concepts are evaluated. The evaluation criteria are setup in the system analysis and will be used in this step. A multi-criteria analysis is carried out for the evaluation and results in the selection of the most suitable concept. The evaluation process results in an answer to the fourth research sub-question.

8. Optimisation of the channel layout

For the selected concept, an intervention is proposed. The goal of the intervention is to create a morphologically more stable channel with a reduced need for maintenance dredging. The implementation of the intervention requires additional computations by the model and a reevaluation of the selected concept. This stage allows to give an answer to the fifth research sub-question. The optimisation is described in Chapter 8.

Finally, Chapters 9 and 10 form the discussion on the research and the conclusions and recommendations on the research, respectively.

2 System analysis channel design

2.1 Stakeholder analysis

Each project that is executed has parties involved and parties that are influenced by it. These related parties always have a certain interest in the project and therefore are often called stakeholders. These stakeholders could make a project to a success or antagonise it, which may result in more costs or no execution at all. Therefore, it is important to include an analysis of these stakeholder in the project. With the most involved stakeholders known, requirements and wishes based on their interests can be setup. This analysis will follow the procedure of the studies by (ODA, 1995) and (MacArthur, 1997). This procedure is followed by first indicating the involved stakeholders and their relationship to the project, which is done in the first section. Next, the most important interests are discussed and these interests are scored for every stakeholder. Finally, based on the interests and influence of the stakeholders, the rate of involvement is determined and the most involved stakeholders are indicated. The interests of the stakeholders will be the reason to determine the requirements and evaluation criteria of the project, depending on the involvement of the stakeholder.

2.1.1 Stakeholders inventory

The stakeholders that are considered, are the ones involved in the project of the layout of the tidal lake and in particular the design of the discharge and navigation channel within the tidal lake. The stakeholders are divided into four categories, which indicates the influence to the project with respect to each other. The four categories are indicated and shortly explained below as well as the corresponding stakeholders which are divided over these categories.

1. Public Service Providers.

These are the most important stakeholders, usually the client of the project.

A: Rijkswaterstaat

2. Private Service Providers.

These are the executives that are responsible for the design, construction and investments of the project. These are thus together all involved in the processes regarding the project.

B: Contractors & Engineering firms

C: Dredging companies (maintenance)

D: Investors

E: Waterboard Hollandse Delta

F: Ministry of Infrastructure and Water Management

3. Core Stakeholders.

These are stakeholders that do not have much influence in the project, but are influenced by it. Usually, these are the users and secondary stakeholders of the project.

G: Natura2000

H: Municipality of Goeree-Overflakkee

I: Municipality of Westvoorne

J: Province of Zuid-Holland

K: Port of Stellendam

4. Periphery Stakeholders.

These are stakeholders with very low influence and which may be impacted by the construction and area transformation.

L: Port of Goedereede (Ouddorp)

M: Local fishing companies

2.1.2 Stakeholder interest

Every stakeholder that is involved in this project of designing the layout of the tidal lake has certain interests which are connected to the project. In this section, the main interests, which are important for the project, are discussed. To indicate the connection between the stakeholders and the interest, 2.1 is provided, which also emphasizes the amount of stakeholder's interests.

Table 2.1: Stakeholder's interests (interest: (x) and no interest: ())

Interest	A	B	C	D	E	F	G	H	I	J	K	L	M
Flood protection	x	x	x	x	x	x	x	x	x	x	x	x	x
Navigability	x	x	x	x	x	x		x	x	x	x	x	x
Nature preservation	x		x	x	x	x	x	x	x	x			x
Recreational impact	x			x	x		x	x	x	x	x	x	
Construction hindrance	x	x	x	x	x	x	x	x		x	x	x	x
Maintainability	x	x	x	x	x	x	x	x	x	x	x	x	x

Flood protection

The interest of flood protection is important, besides being one of the main purposes of Delta21, for the areas around the tidal lake. The tidal lake layout should adhere to securing flood protection, which is also connected to the requirement for discharge capacity. Many surrounding stakeholders have interest in securing flood protection and is therefore included as an interest.

Navigability

Navigability is included as an interest due to the fact that fishery by local fishing companies is executed in and outside the Haringvliet mouth as well as recreational vessels from nearby municipalities that sail through the Haringvliet mouth. After construction of Delta21, the interest of remaining navigability in the tidal is thus important for local stakeholders.

Nature preservation

The tidal lake will become a tide dominant system with tidal nature. Also, the area is part of Natura2000 and thus follows regulations of nature preservation. Many stakeholders should adhere to these regulations and others have the interest of preserving the natural value in the tidal lake. Therefore, this interest is of importance for several stakeholders.

Recreational impact

As mentioned already, the tidal lake will be used by recreational vessels from nearby municipalities and port. Also, nearby beaches at Goeree-Overflakkee, Oostvoorne and Rockanje are popular recreational sites. Therefore, local municipalities and ports have the interest to preserve these recreational options when Delta21 is constructed. Delta21 will enable new recreational options, which could be of interest for certain stakeholders as well.

Construction hindrance

The interest of construction hindrance is a relatively short-term interest of being executed in a good course. The construction hindrance mainly refers to the initial dredging and additional works for the

tidal lake layout. Large hindrance may for instance have an impact on local companies that sail through the tidal lake for their business. Therefore, this interest is included in the analysis.

Maintainability

The maintainability is included as an interest, because this may cause hindrance as well, but also the costs and repetitiveness of the maintenance is an important aspect for several stakeholders.

A scoring mechanism per stakeholder is performed to indicate how strong an interest of the stakeholder is expected to be. Project costs are not indicated in this section, since this may beforehand influence the essence of the type of interest. Therefore, the costs will be discussed later in the evaluation stage. Note, that the investors are most interested in the costs, but these should be included in the analysis. So in this scoring, the interests of the investors regarding costs are assumed in a more qualitative matter instead of quantitative. Four scores of interest are distinguished; very strong, strong, average and no. The scores per stakeholder are given in Table 2.2, where the capital letters represent the stakeholders as stated before.

Table 2.2: Interests of Stakeholders (interests: very strong (++), strong (+), average (0) and no interest (-))

Interest	A	B	C	D	E	F	G	H	I	J	K	L	M
Flood protection	++	+	0	++	++	+	0	++	++	+	+	+	0
Navigability	+	+	+	+	+	++	-	0	0	0	++	++	++
Nature preservation	+	-	0	+	+	+	++	0	0	0	-	-	+
Recreational impact	+	-	-	0	0	-	+	++	++	+	+	+	-
Construction hindrance	0	+	+	0	+	0	0	0	-	0	+	0	+
Maintainability	+	+	++	+	+	+	+	0	0	0	+	0	+

2.1.3 Stakeholder involvement

Besides the interest of a stakeholder in the project, the amount of influence of the stakeholder is important to include. Combining these parameters results in the involvement of the stakeholder in the project. So, large interest and influence results in large involvement and decreasing interest and influence results in decreasing involvement. The involvement of a stakeholder is an indication of when they get involved in the project and which interests are respected in the requirements of the project. A highly involved stakeholder is included from the start of the project and has a large share in setting up the design requirements. It is important to have an overview of the most involved stakeholders in order to successfully execute the project. Of course the other stakeholders are still considered in the project, but with decreasing involvement the stakeholder is included later in the project and has less contribution to the project requirements and execution.

The stakeholder involvement is graphically represented in Figure 2.1, where the influence is estimated and a relation is made between influence and interest per stakeholder. From the figure, the most involved stakeholder can be found in the top right and conversely the least involved at the bottom left.

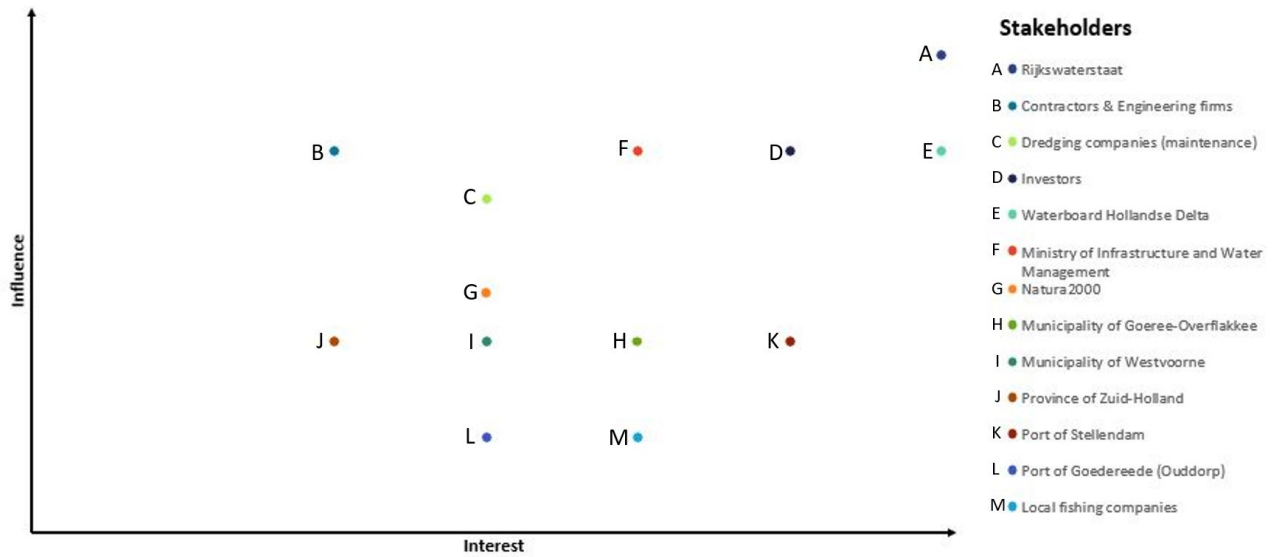

Figure 2.1: Stakeholder involvement considering interest and influence.

The above figure indicates clearly that Rijkswaterstaat is the most involved stakeholder in the project. Other high scoring stakeholders are the waterboard Hollandse Delta, the investors and the Ministry of Infrastructure and Water Management.

2.2 Functional analysis

In this section, the functional analysis is explained for the tidal lake layout and in particular the navigability and discharge channel in the tidal lake. The functions are accompanied with requirements that follow, which are listed in the next section. The functional requirements will be the guidelines for the design process. The functions are divided into principal and preserving entities, in order to provide a distinction within.

The functions of the channel can be formulated as follows:

Principal functions

1. Allow discharge to flow from the Haringvliet barrier to the energy storage lake.
2. Provide navigability for vessels between the port of Stellendam and the storm surge barrier of Delta21.

Preserving functions

3. Preserve natural value after construction and maintenance works of the following:
 - Water quality
 - Bottom life
 - Tidal nature
4. Preserve recreation in surrounding area of tidal lake.
5. Preserve fishery in the tidal lake.

Additional functions

Regarding this design, there are no notable additional functions inside the scope of this report.

2.3 Requirements

The requirements for the channel design are explained in this section. The requirements are given for each function and are divided for the principal and preserving functions in sections 2.3.1 and 2.3.2 respectively.

2.3.1 Principal functional requirements

The principal functions are accompanied by requirements that should hold for the design. The requirements are described considering the “SMART” approach (Specific, Measurable, Attainable, Reasonable, Traceable). These requirements will be verified for every design in later sections, followed by evaluation of the verified designs in a multi-criteria analysis. Several requirements include quantitative and qualitative restrictions that have been considered.

The maximum pumping capacity of Delta21 is assumed for the requirement for the discharge function. This is for the situation when the spillway is open and the storm surge barrier closed. The geometry of the channel should at least have the capacity for a discharge of 10,000 m³/s.

The navigability requirements are regarding the vessels that are currently using the Voordelta and the Slijkgat. These are mainly small fishing ships, but also larger vessels that sail through the Goereesluis (lock) at the Haringvliet barrier. The Goereesluis allows for CEMT-class Va vessels to sail through. Therefore, the dimensions of CEMT-class Va are required for the channel as well. Except for the required draught, which should be larger to allow for all current fishing ships to sail when loaded. The intensity of the Slijkgat is high enough to cause congestion and delay, when applying a one way channel. Therefore, a double lane channel is required for the design to allow for two way passing. Moreover, safe navigation is required as well, which is mainly based on safety in sailing and manoeuvrability. Therefore, restrictions on longitudinal and cross current velocities are considered.

The requirements which are connected to the principal functions are listed below. Further reasoning and argumentation for these restrictions is described in Appendix A.

1. Discharge function:

- 1.1 The geometry of the discharge channel provides capacity for a discharge of 10000 m³/s, during a high water wave of one week, to flow to the spillway, considering a closed storm surge barrier.

2. Navigability function:

- 2.1 Provide a double lane channel for the normative fishing and recreational vessels under normal conditions with the spillway closed.
- 2.2 Vessels up to CEMT-class Va are at least able to sail through the channel under normal conditions with the spillway closed.
- 2.3 A loaded vessel with a draught of 5.00 meters can sail through the channel under normal conditions with the spillway closed.
- 2.4 Safe navigation with maximum longitudinal flow of 1.50 m/s is provided, considering a discharge with a probability of exceedance of 10%.
- 2.5 Safe navigation with cross flow of 0.75 m/s is provided, considering a discharge with a probability of exceedance of 10%.

2.3.2 Preserving functional requirements

The requirements which follow from the preserving functions are listed below. Unlike the requirements for the principal functions, the following are not described in a SMART manner. This is because the

quantifiable verification of these requirements is outside the scope of this thesis research. These requirements are however mentioned to indicate the importance of the particular stakes. Requirements 3.3 and 3.4 can be verified in a qualitative manner and will be considered as an evaluation criterion, in order to not neglect those stakes in the design process.

3. Nature preserving function:

- 3.1 Construction of the channel and other measures in the tidal lake do not result polluted water quality.
- 3.2 Construction of the channel and other tidal lake measures should minimize the negative impact on the bottom life in the tidal lake.
- 3.3 Construction of the channel and other tidal lake measures should allow the tide to flow in and out of the tidal lake, for which changes in the tidal nature on and around the tidal flats should be minimised.
- 3.4 The impact by structural interventions in the tidal lake should in particular be minimised for the banks: The Hinderplaat, Garnalenplaat, Slikken van Voorne, Kwade Hoek and Bollen van de Ooster.

4. Recreational preserving function:

- 4.1 The effects by structural interventions in the tidal lake on recreational activities at current locations such as the beaches of Oostvoorne and Rockanje should be minimised.
- 4.2 Recreational sailing activities should be preserved in the tidal lake.

5. Fishery preserving function:

- 5.1 The current fishery in the tidal lake is still operational.

2.4 Evaluation criteria

Additional to the requirements, evaluation criteria are taken into account for the design. The criteria are subdivided under three stakeholder interests from Section 2.1.2. These criteria will be scored in a multi-criteria analysis in a later section. Some criteria are similar to certain requirements, but aim to indicate the degree of a phenomena to occur between concepts instead of a fulfilment of a requirement.

2.4.1 Navigability

Navigability is one of the interests for which evaluation criteria are formulated. The first criterion is the necessity of maintenance after an extreme event. In this case an extreme event is the situation where the storm surge barrier is closed and the spillway open and a discharge larger than 9000 m³/s flows through the tidal lake. The effect of this event could result in short-term sedimentation and hinder navigability. This is not included as a requirement due to the uncertainty of such an event to happen. Therefore, it is included as a criterion for sporadic maintenance necessity.

The second criterion considers the change of location and orientation of the channel due to morphological changes over time. Change in orientation and location does not pose a threat for the requirements, but may cause hinder for sailing due to frequent change in navigating through the channel. Also, it may result in manoeuvrability hinder of the vessels for large changes in orientation.

The third criterion is the hindrance by current flows in the channel, both in longitudinal and cross direction. Requirements have been set on these phenomena and the criterion supports these by quantitatively assess the flow patterns that occur and may threaten the safety of navigation and how often (besides the required exceedence probability) an unsafe situation may occur. The evaluation thus considers the rate of occurrences of safety threats as a comparison between different concepts.

Additionally, the velocity gradients along the channel are of importance. Especially gradients in cross currents may cause large cross forces on a vessel, which hinder manoeuvrability.

2.4.2 Maintainability

Due to sedimentation of the channel, frequent dredging will be needed to keep on meeting the requirements. The repetition for dredging and the amount to be dredged is different for each situation and is therefore not specified as a requirement. Three criteria are defined for the maintainability. The first criterion regards the volume to be dredged. The dredging is part of the maintenance of the channel, where large amounts of dredged material results in larger costs.

The repetition of the dredging operations is the second criterion to consider. High repetition of dredging results in additional operational costs, excluding the dredging, such as high mobilisation and organisation costs if the vessel should come from a distant location. Also, the dredging vessel might be unavailable more often in case of repetitive use, providing that a long-term maintenance contract has not been awarded for high repetition. Therefore, this criteria is considered for the maintainability.

It is assumed that the volume to be dredged in the first year will be different in the years after. It may either become better or worse in terms of amounts of dredged material. To have insight in both the short-term and long-term morphological changes, allows a well consideration of what results in lower costs over time. It differs from the first criteria, where the volume of one year is considered.

2.4.3 Nature preservation

Nature preservation is in this case considered as the combination of the flora and fauna in the tidal lake and the sand banks that are present in the current situation. Flora and fauna rely on the tidal nature and the morphology of it. Seals and waders for instance regularly are stationed on and around the Hinderplaat and bottom life thrives in tidal flats by the tidal behaviour. However, the effect on the flora and fauna is not included in the scope of this research and can not be quantitatively assessed by the results from the modelling study. Therefore, a criteria is set on the preservation of the currents sand banks and intertidal areas. Morphological changes of these areas can be assessed and changes or disappearance of these banks will be a direct threat in preserving the flora and fauna.

2.4.4 Conclusive set of evaluation criteria

The explained criteria are listed below for each interest:

1. Navigability

- 1.1 Navigability after extreme event with open spillway and closed storm surge barrier.
- 1.2 Undesired location and orientation change of the channel over time.
- 1.3 Navigability hindrance by flow under normal conditions.

2. Maintainability

- 2.1 Required sedimentation volume to be dredged per year (Mm^3), considering normal conditions.
- 2.2 Maintenance dredging repetition, which requires (additional) operational costs and availability of the hopper.
- 2.3 Required maintenance dredging volumes in the second year, with respect to the dredging volumes of the first year.

3. Nature preservation

- 3.1 Preservation of current sand banks and intertidal areas.

3 Processes analysis of research area

This chapter describes how morphodynamic processes and human interventions have shaped and will shape the Haringvliet mouth. This is relevant in order to obtain insight in the processes that will likely influence the channel. First, in Section 3.1, the interventions over the past decades in and around the area are discussed, including the consequences. Next in Sections 3.2 and 3.3 the hydrodynamic processes and morphodynamic components are discussed respectively. Finally, Section 3.4 concludes on the chapter and answers the second research sub-question: *What is the qualitative morphological development in the tidal lake of Delta21 and what hydraulic components contribute to this development?*

3.1 Interventions in the Voordelta

3.1.1 The Voordelta

The area of interest of this research is the Haringvliet mouth (Figure 3.1b), which is part of the so-called Voordelta. The Voordelta, which is depicted in Figure 3.1a, is a collection of four estuaries that stretches from Hoek van Holland in the north, to below Zeebrugge in Belgium in the south. These estuaries are traditionally a system of the river distributaries, from north to south; Brielse maas, Haringvliet, Grevelingen, Eastern Scheldt and Western Scheldt. These distributaries originate from large river systems, where respectively the first four are distributaries of the Rhine and Meuse and the Westernschelde is a distributary of the river Scheldt. The estuaries are bounded on their seaward end by coalescing ebb-tidal deltas. The ebb-tidal deltas form a relatively shallow, up to 10 km wide offshore area that stretches over the Voordelta.

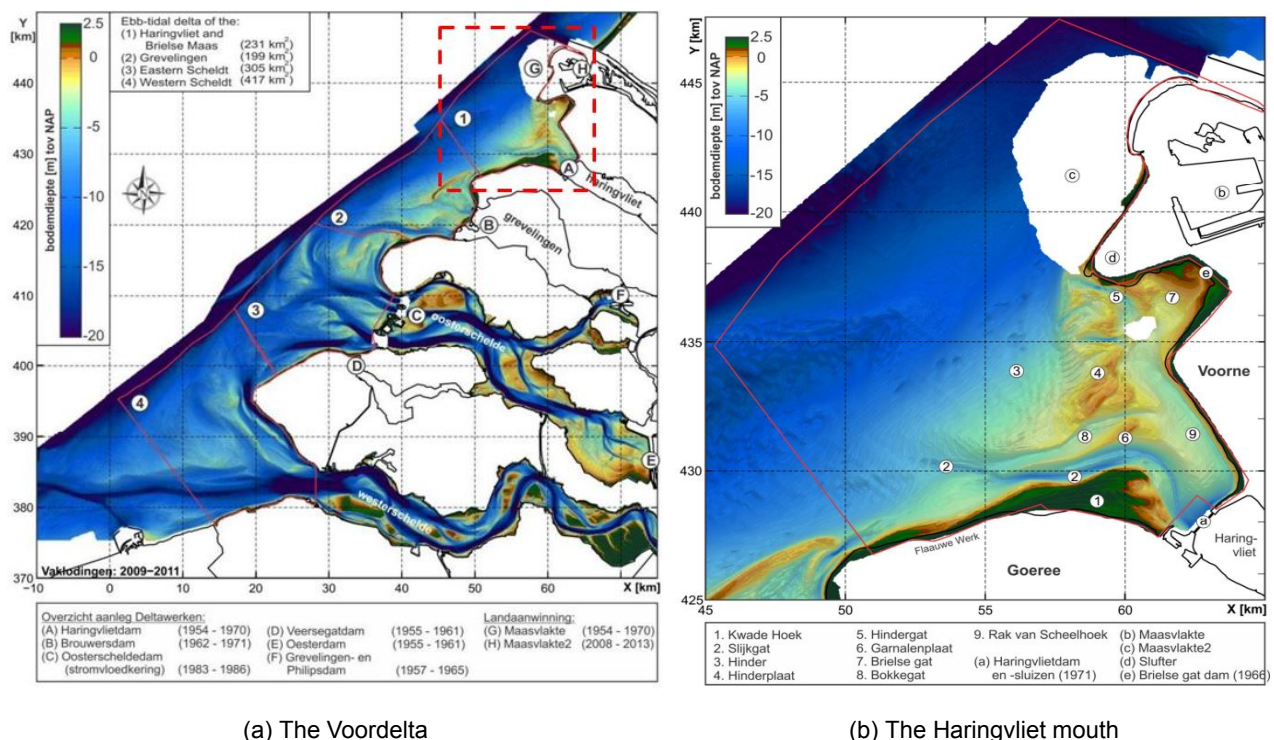

(a) The Voordelta

(b) The Haringvliet mouth

Figure 3.1: (a) The Voordelta, which consists of the four indicated ebb-tidal deltas. A red frame indicates the left figure. (b) The Haringvliet mouth with indicated components. (Elias & van der Spek, 2014)

The dominant forcing mechanisms in the Voordelta are tides and waves. Strong tidal currents together with strong winds, create a highly dynamic environment that consists of rapidly shifting, shallow bars and shoals. These bars and shoals are divided by deep tidal channels. The wave climate in the area consists mainly of wind waves locally generated in the shallow North Sea basin (Elias et al., 2016).

These forcing mechanisms result in a dominant sediment transport direction from south to north. This can be observed in Figure 3.1, where the average depth decreases and shoal areas increases in northern direction. The latter is also influenced by the interventions in the Voordelta, especially at the northern boundary.

3.1.2 Interventions in the Haringvliet mouth

The main interventions in and around the Voordelta are the Delta Works and the expansions of the Port of Rotterdam. The Delta Works is a flood defence system, consisting of a collection of storm surge barriers, locks and closure dams in the southwest Dutch delta. The Delta Works follow the so-called Delta plan, which is an initiation to improve flood protection in the southwest Dutch delta and was soon executed after the 1953 flooding of the province of Zeeland and surrounding areas (Rijkswaterstaat, 1972).

For the Haringvliet mouth, the most important intervention from the Delta plan is the Haringvliet barrier. This barrier with sluices is placed between the Haringvliet and what is now called the Haringvliet mouth. This has resulted in closing off the Haringvliet from the sea, where hardly any salt intrusion is allowed to flow through the sluices. The closing strategy was set on closing the barrier for flood conditions and open it for ebb conditions and discharge water from the upstream river delta. Besides the Haringvliet barrier, there are many interventions carried out in and around the Haringvliet mouth, which have resulted in a sheltering area and blockage of alongshore sediment transport. This has led to significant sedimentation in the area, for instance the developed and growing Kwade Hoek and the sedimentation of the tidal channels, where only the Slijkgat has remained. The interventions that have led to the current morphology and hydrodynamics in the Haringvliet mouth are listed in Table 3.1 as well as the maintenance operations in the area over the past decades. Specifically the Slijkgat is dredged until this day, where the channel is kept to a width of 100 m and a depth of NAP -5.5 m (TenderGuide, 2020).

Many studies have researched the change in hydrodynamics and morphology over the years in the Haringvliet mouth (Elias & van der Spek, 2014; Elias et al., 2016; Elias & van der Spek, 2021; Colina Alonso, 2018). These features are considered for this research as well, but are not discussed extensively. For further insight on the development of the Haringvliet mouth, one is referred to previous studies.

Table 3.1: Interventions that influenced the evolution of the Haringvliet mouth (Adjusted from Colina Alonso (2018)).

Year	Construction works
1950	Damming Brielse Maas, creating the Brielse Lake
1957-1970	Construction of the Haringvliet barrier
1966	Second closure of the Brielse Gat, creating the Oostvoorne Lake
1971	Closure by the Brouwersdam
1964-1966	Construction of Europoort
1967-1976	Construction of Maasvlakte 1
1986-1987	Construction of the Slufter
2008-2013	Construction of Maasvlakte 2
Dredging maintenance and nourishments	
1969-1985	Sand nourishments to strengthen the coast of Goerree
1973-1993	Sand nourishments to strengthen the coastline and dunes of Voorne
1983-now	Maintenance dredging Slijkgat channel
1986-1987	Dredging operations Hindergat
1991-2005	Slufterdam sand nourishments
1991	Dynamic Maintenance policy Voorne and Goerree

Closing strategy Haringvliet sluices

The Haringvliet barrier has resulted in major changes in the Haringvliet mouth. The Haringvliet barrier has a span of approximately 2 km, with a 1.05 km long stretch of sluices where water can flow through. There are 17 openings that can be regulated independently, which combined allow for a maximum discharge of 25.000 m³/s to flow through (Blokland et al., 1970). The sluices are regulated by following a certain closing strategy. Until 2018 the LPH'84 strategy was applied for the Haringvliet sluices. This meant closing the sluices at flood flow and open in non-flood conditions, depending on the Rhine discharge at Lobith (Rijkswaterstaat, 1984). It was closed for discharges smaller than 1100 m³/s, one sluice open for discharges up until 1700 m³/s and from there almost linearly open with respect to the discharge at Lobith. This was set, because approximately 1500 m³/s from upstream rivers flows through the Nieuwe Waterweg and the surplus to that through the Haringvliet. Therefore around 1700 m³/s and above, the Haringvliet sluices should discharge to the sea.

Since 2018 there is another strategy applied on the Haringvliet sluices; the so-called Kierbesluit. The opening and closing of the sluices for the Kierbesluit is the same as for ebb and flood flow and only depends on the river discharge at Lobith (see Figure 3.2). This to allow more salt intrusion in the Haringvliet, which results in reintroducing the estuary properties of the Haringvliet from before the closing by the Delta Works. This in order to restore ecological value and the dynamic delta nature in the Rhine and Meuse estuary, which has disappeared in the area. The effects of introducing salt intrusion by the Kierbesluit are still assessed (Noordhuis, 2017). However, it is already applied and will thus be assumed as strategy for this research as well. It is too in line with the purposes of the Delta21 project.

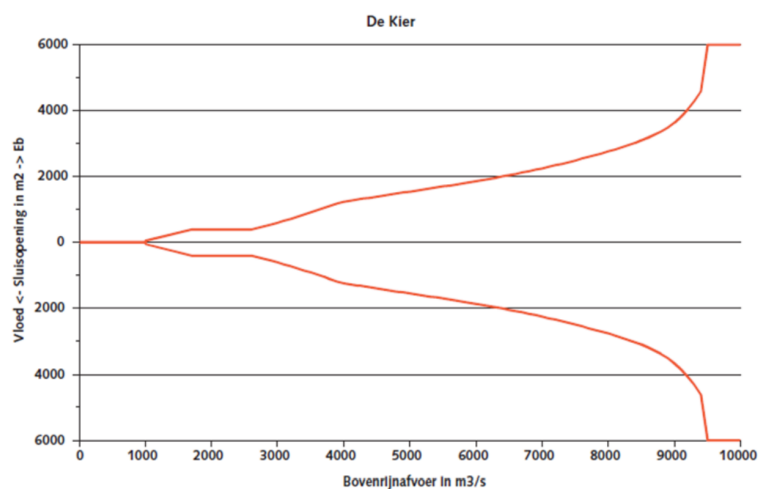

Figure 3.2: The opening and closing strategy of the Kierbesluit at the Haringvliet sluices, depending on the upstream river discharge at Lobith (Noordhuis, 2017).

3.2 Hydrodynamics

In this section the hydrodynamic components in the Haringvliet mouth are introduced for the current situation. These components are the tide, wind and the corresponding generated waves and discharge. Several assumed changes will be discussed when Delta21 is integrated and the tidal lake is formed.

3.2.1 Tide

The tide in the North sea is characterised by a semi-diurnal tide, which approximately results in two high and low waters each day. Along the Dutch coast, the tidal range decreases from south to north, with a tidal range of 3.8 m in Vlissingen and 1.4 m in Den Helder. The Haringvliet is situated in the south and has a tidal range of approximately 2.1 m (de Vries, 2007). The tidal signal of winter months January and February is shown in Figure 3.3, which clearly shows the spring-neap cycle. Also, the tidal levels are indicated on the right of the figure, which are based on the two month data.

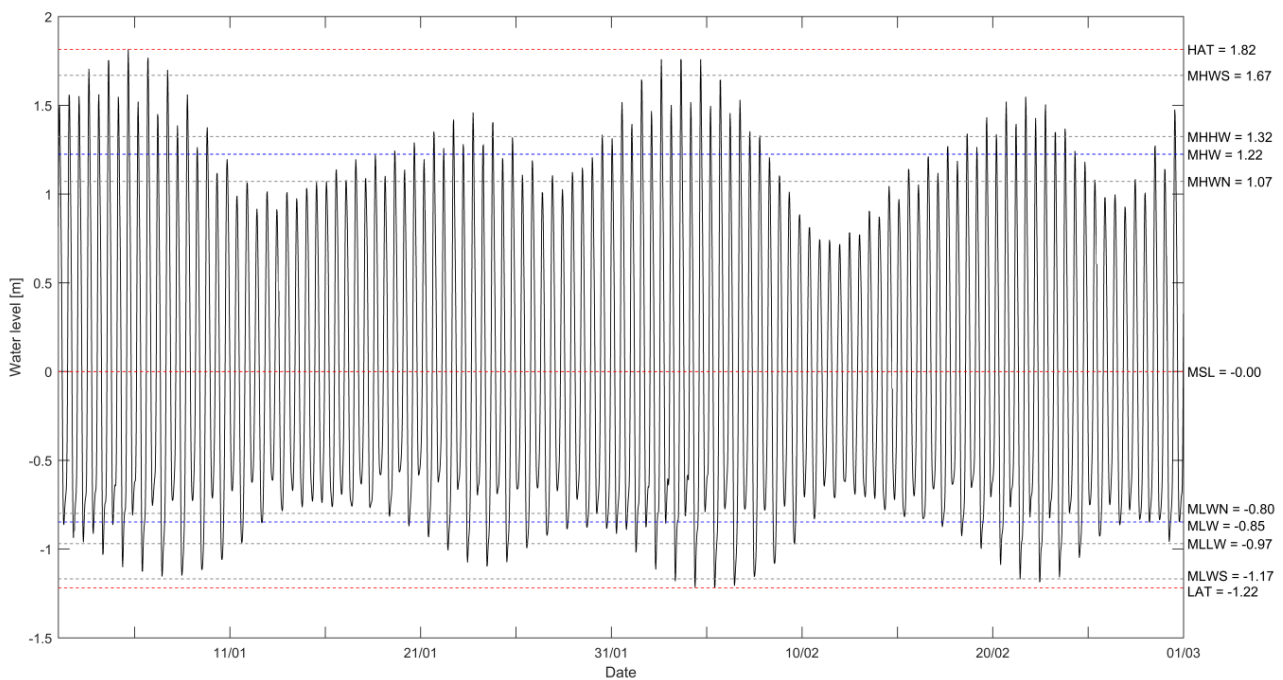

Figure 3.3: Tidal signal containing four spring-neap tidal cycles in front of the Haringvliet outer delta (Colina Alonso, 2018)

As mentioned in the previous section, construction of the Haringvliet barrier had a large impact in the area, also on the tidal forcing. Before closure, the Haringvliet estuary was a long tidal basin with a phase difference between the tidal velocity in the estuary and the velocity along the coast (Sha & Berg, 1993). Figure 3.4 shows the changed tidal environment before and after the closure. Four phases of the tidal cycle are described by Tönis et al. (2002) for each situation and before the closure these are as follows:

- phase 1: at high tide, flood currents occur outside as well as inside the estuary.
- phase 2: about 3 h after high tide, the current outside the estuary is in flood direction and inside in ebb direction (water flows from the estuary to the sea).
- phase 3: at low tide, ebb currents occur both inside and outside the estuary.
- phase 4: the current at sea is in ebb direction and inside the estuary in flood direction, entering the landward part of the estuary.

After the closure, the tidal currents show a more circular character and the previously used tidal channels are not distinguished by this flow anymore. The estuary has shifted to a short basin and a decrease in tidal prism. The latter has resulted in a decrease in current velocities and consequently current patterns. The phases after the closure are:

- phase 1: at high tide, the water enters the estuary at the south side and leaves the estuary at the north side.
- phase 2: about 3 h after high tide, the current inside the entire estuary is in ebb direction.
- phase 3: at low tide, the water enters the estuary at north side and leaves from the south side.
- phase 4: the current at sea is in ebb direction and inside the estuary in flood direction

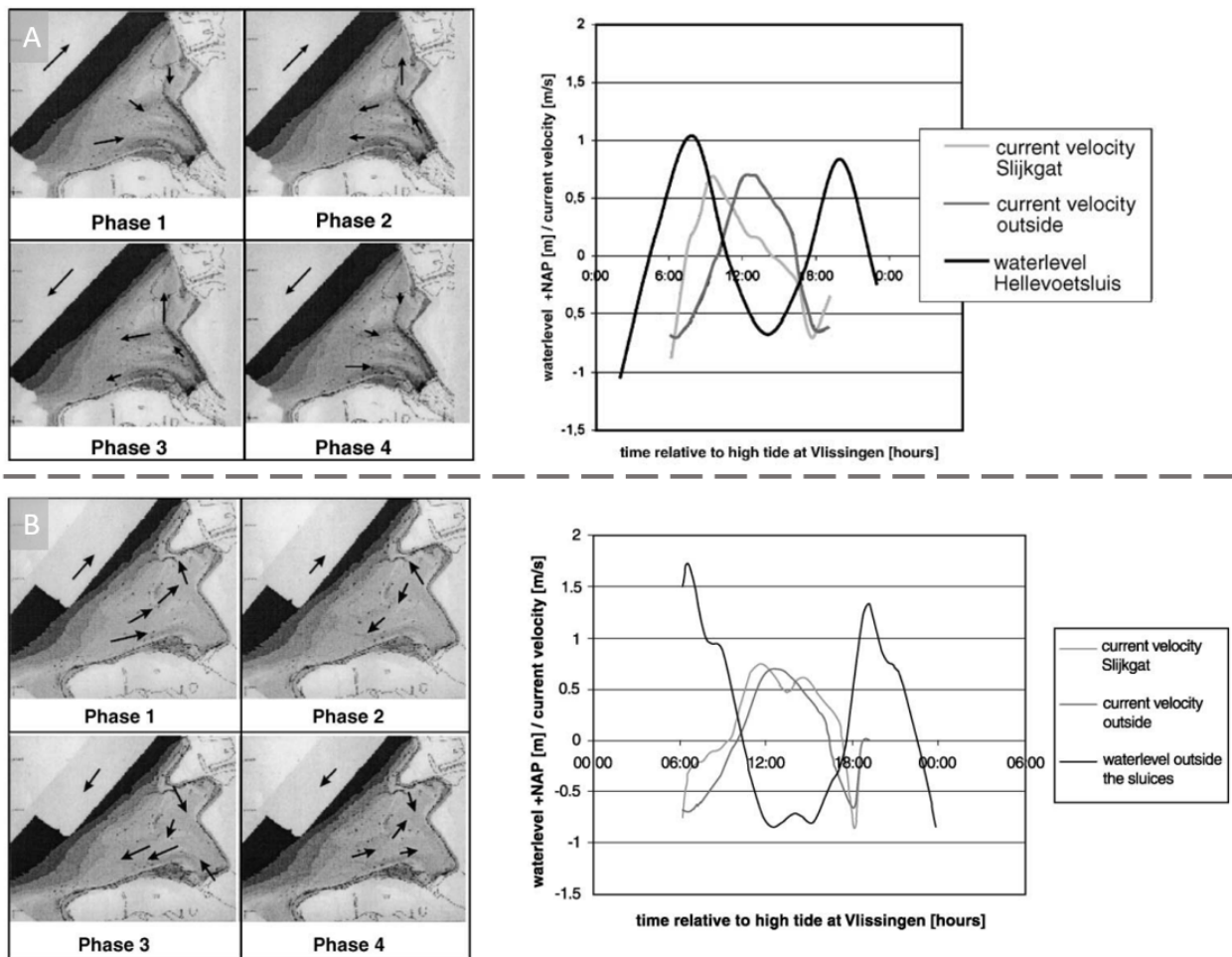

Figure 3.4: Tidal propagation in the Haringvliet estuary and mouth. A: Flow patterns and velocity and water level signals before closure, B: Flow patterns and velocity and water level signals before closure after closure (Tönis et al., 2002).

Implementation of Delta21

The figure above, including the description of the phases, show the significant change in tidal forcing in the Haringvliet estuary after closure. With the construction of Delta21, the change in tidal forcing and propagation will be significant as well. The sheltered tidal lake will be dominated by the tide and the river discharges. The tidal prism will change, which leads to change in current velocities, together with changes in velocities by the geometry of the tidal lake. For instance the velocities at the inlet will increase and decrease in the north. Similar to the closure, the tidal range will change, as well as phase lags between water levels and flow velocities. The change in tidal prism is thus a parameter to consider in order to motivate changes in flow and sediment transport in the tidal lake. Therefore, the change in tidal prism is considered to be presented in the results of the modelling study.

For this research, the water levels and velocities are considered as a result of the tidal signal given in Figure 3.3 as a reference. This signal originates outside of the tidal lake and will be the reference of the initial tidal forcing. Further adjustments to the applied tidal signal is discussed in later sections.

3.2.2 Wind generated waves

Wind may cause setup and locally generated waves in the tidal lake. These could result in velocity currents, which may cause sediment transport. Therefore, the wind is another important forcing to take into account. For the analysis on wind, meteorological data is used, measured by the KNMI (2022). The data covers 50 years (1972-2022) of measurements of wind speeds at Hoek van Holland, which is

the nearest location to the tidal lake with such extensive data. The data of the maximum hourly mean is selected as most useful for this research. This parameter is considered most useful for an extreme value analysis, which also results in a normative distribution for hydrodynamic forcing by wind in the tidal lake. Based on the wind data, a windrose is provided in Figure 3.5 to indicate the dominant wind directions and wind velocities. The most dominant wind directions, considering both occurrence and velocity magnitude, are the west (W), west southwest (WSW), southwest (SW) and south southwest (SSW). The data from these four directions are used for further analysis on the normative wind speed.

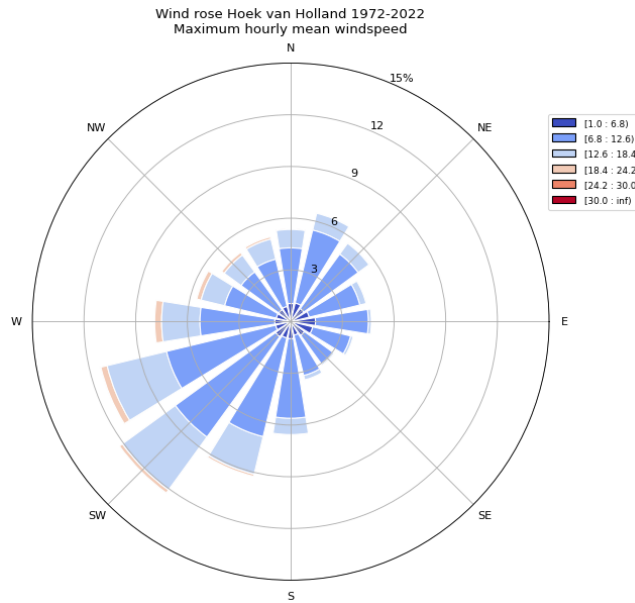

Figure 3.5: Windrose of maximum hourly mean data at Hoek van Holland.

The extreme value analysis that is considered for the wind data is done by applying a Three-parameter Weibull distribution, which is commonly used for this type of data (Wais, 2017). The expression of the distribution as function of the return period is given in Equation (3.1). The three parameters γ , α and β are different for every wind direction data-set and are parameters that obtain the best Weibull fitted distribution for every wind direction.

$$R = \exp \left(\left(\frac{v - \gamma}{\alpha} \right)^\beta \right) \quad (3.1)$$

Where:

- R : Return period
- v : Maximum hourly mean wind speed
- γ : location parameter
- α : scale parameter
- β : shape parameter

Based on the return period, a wind speed can be obtained, which can be used for further analysis on the forcing as a result of wind. The wind speed is calculated by the rewritten expression in Equation (3.2). The return periods that are chosen for further analysis are 1, 10, 100 and 1000 years. Where long-term effect by wind is considered most interesting. So, the wind speeds of lower return periods that are likely to occur more often and for a long period of time. Those wind speeds will mainly be

used to obtain hydrodynamic forcings by wind. The higher return periods and wind speeds are used as a reference.

$$v = \alpha \sqrt[\beta]{\ln R} + \gamma \quad (3.2)$$

The calculated wind speeds for every direction has been displayed in Table 3.2 for the three return periods. The data in the table shows insignificant wind speeds, relative to the return periods. It depends on the fetch over which the wind can setup waves that stimulates sediment transport. These wind speeds are unlikely to result in significant sediment transport by waves with respect to the tide and river discharge.

Table 3.2: Wind speeds [m/s] from the dominant wind direction for different return periods.
 $\alpha = 8.31$, $\beta = 2.05$ and $\gamma = 2.93$

Direction	W	WSW	SW	SSW
R=1	6.05	6.67	6.65	6.21
R=10	16.63	16.02	15.48	14.81
R=100	21.82	20.07	19.10	18.41
R=1000	25.72	22.99	21.67	20.98

An additional analysis has been carried out of the impact of the wind on wave setup in the tidal lake. The analysis is described in Appendix B and determines the maximum orbital velocities, which are related to the wave setup. The orbital velocities of the normative wind direction (west) is given in Table 3.3 for each return period.

Table 3.3: Orbital velocities (\hat{u}) for western wind direction for four return periods.

	\hat{u} [m/s]
R=1	0.19
R=10	0.56
R=100	0.74
R=1000	0.88

When considering the velocity amplitudes in the table, there is a gradual increase for the longer return periods. There are thus no significant increases of the orbital velocity in heavy storm conditions. With respect to the tidal velocities, the wave velocities are only a small percentage of the maximum tidal in- and outflow (1.5-2.0 m/s). For the high return periods, the storm surge barrier is assumed closed, so no tidal in- and outflow, which means there is no forcing by the main driver for high velocities. Therefore, for high return periods, the wind waves are not considered significant for sediment transport with respect to the tidal flow and discharge in the daily conditions. Also, the occurrence of these wind speeds are of a very short time (a few hours), with respect to the daily conditions. So, in terms of morphological changes, such short time and insignificant orbital velocities are not assumed normative.

The velocities that have a high occurrence rate are of more importance. The one year return period for the western wind speeds results in an orbital velocity of 0.19 m/s, which is around 10% of the maximum tidal velocity. This too is not considered a significant magnitude of a velocity in and around the channel, even though it could happen more often. Therefore, the effect by wind waves are not considered normative at all for the modelling study.

3.2.3 Sea waves

Of all characteristics in the tidal lake, the sea wave component will be affected the most by Delta21. The dammed structure of Delta21 secures almost full sheltering from sea waves entering the tidal lake. The only interaction is through the new storm surge barrier. However, due to the narrowing section at the seaside of the storm surge barrier, sea waves are assumed not to result in significant waves entering the tidal lake. These waves either refract to the dune sections at the sides of the narrowing or, when really significant, will be blocked by a closed storm surge barrier. Therefore, hydrodynamic forcing by ocean waves are not considered for this research.

3.2.4 River discharge

The river discharge has been a dominant hydrodynamic component for the Haringvliet estuary. For the past decades, the discharge has been regulated by the closing strategy of the Haringvliet sluices. The Kierbesluit is the most recently applied strategy and is used for this research. The discharge entering the Haringvliet originates from the combined Rhine and Meuse discharges. These discharges eventually reach the sea through the Nieuwe Waterweg and the Haringvliet. An overview of the downstream Rhine and Meuse discharge system is given in Figure 3.6. The distribution of the discharge through these rivers depends on the discharge magnitude and the tidal inflow and outflow. For discharges approximately between 0-2000 m³/s, it is tide dominated and varies greatly. However, larger discharges are on average distributed such that 1500 m³/s flows through the Nieuwe Waterweg and the remaining through the Haringvliet (Noordhuis, 2017). For significant upstream discharges, this results in significant discharges through the Haringvliet. Especially high discharges will result in high current velocities in the tidal lake, which enhances sediment transport. This hydrodynamic component is therefore important for further analysis. For further research steps, the explained discharge distribution for higher discharges is assumed.

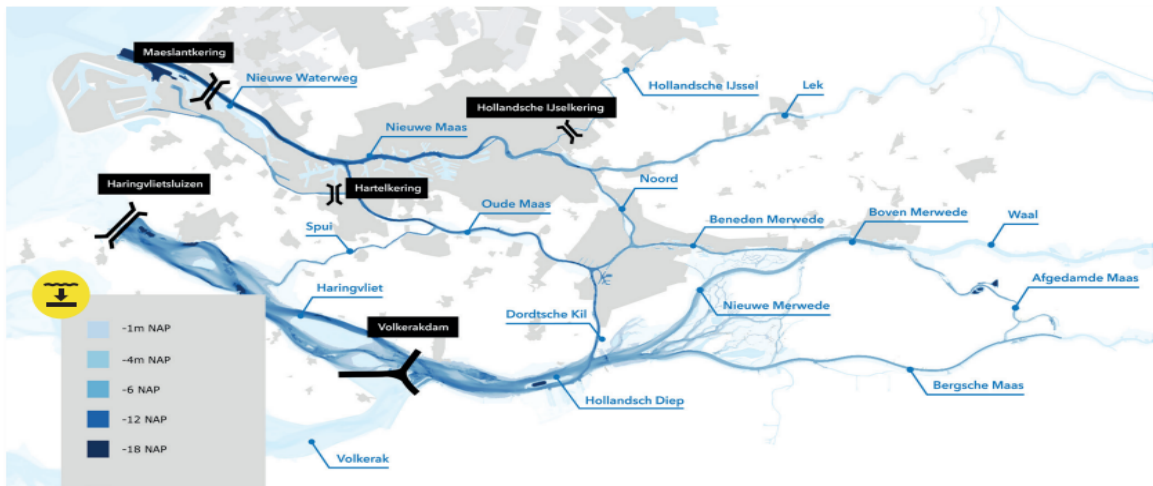

Figure 3.6: Overview of downstream Rhine and Meuse river discharge system. Including the indication of the contributing waterways (Balla et al., 2019).

Delta21 and the closing strategy given in Section 1.2.2, implies closure of the storm surge barrier for a discharge of 7500 m³/s through the Haringvliet. This discharge is used as a maximum discharge for daily conditions, so for an open storm surge barrier and closed spillway. More on the implementation of river discharge as a hydrodynamic component in this research follows in Chapter 5.

3.3 Morphodynamics

This section contains the explanation of the morphological elements in the research area, which contribute to the morphodynamics. The development of the bathymetry and the configuration are discussed as well as the current sediment transport processes and patterns.

3.3.1 Bathymetry

The bathymetry in the Haringvliet mouth has changed over the past decades. As explained in Section 3.1.2, this is mainly caused by closure of the Haringvliet and the extension of the port of Rotterdam. The development of the bathymetry over the past 60 years until 2015 has been visualised by Colina Alonso (2018) in Figure 3.7, by application of the Vaklodingen dataset (Rijkswaterstaat, 2022b). The development can be confirmed by the consequences of the interventions. For instance, the change in tidal behaviour shown in Figure 3.4 before and after the closure corresponds to the response of the change in bathymetry. The additional blockage of the alongshore transport from south to north by Maasvlakte I and II, has resulted in extensive sedimentation in the Haringvliet mouth.

The bathymetry that will be used for this research is based on the most recent Vaklodingen data, which differs for each segment where measurement campaigns have been carried out. The used bathymetry will thus be a combination of the years 2015 until 2019.

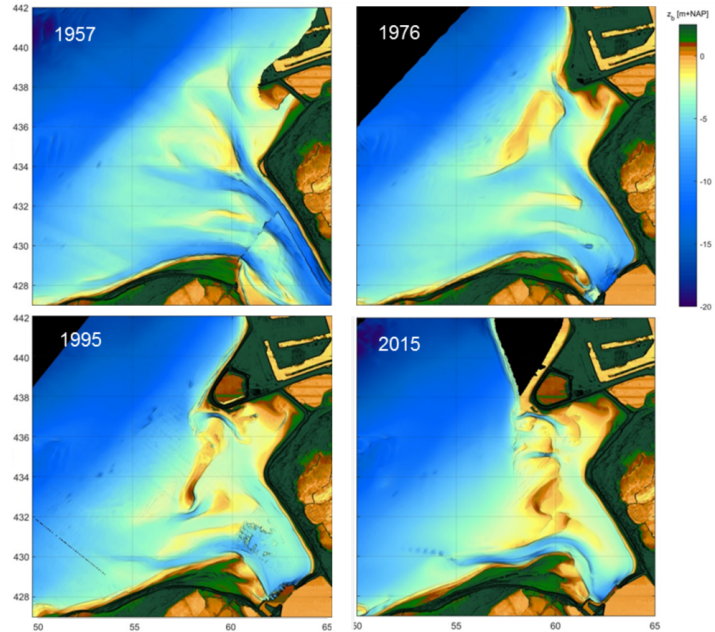

Figure 3.7: Change in bathymetry in the Haringvliet mouth over 60 years, based on Vaklodingen dataset (Colina Alonso, 2018).

3.3.2 Bed composition

Before the closure, most of the sediment was disposed in the ebb tidal delta, when the estuary was developing. The contribution of sediment from the Rhine and Meuse was small with respect to that from the sea and alongshore transport from adjacent coasts. After the closure, the river contribution became even smaller and the Haringvliet mouth was supplied by alongshore transport and the North sea. Deep parts of the North sea supplied the estuary mainly with mud, which nowadays is still present and expands in the sheltered areas (van Vessem, 1998).

Measurements that support the origin of the sediment import in the Haringvliet mouth are given in Figure 3.8. Large grain sizes are present in the ebb tidal delta and in the sheltered Brielse gat, with low mud content. The Rak van Scheelhoek (along the eastern coast) consists of small grain sizes accompanied with higher mud content.

Another measurement campaign by Koomans (2001), three years later, shows a similar distribution of grain sizes over the area (see Figure 3.9). Different measurement techniques have been applied, but show similar patterns in the time span.

Considering the Slijkgat, large grain sizes occur throughout the channel, around 175-200 μm . The mud content is low, which corresponds with the higher grain sizes. Note, that these campaigns are more than 20 years ago, where the Haringvliet mouth has changed since. The Slijkgat has changed in orientation and the Kwade Hoek has developed significantly with respect to two decades earlier.

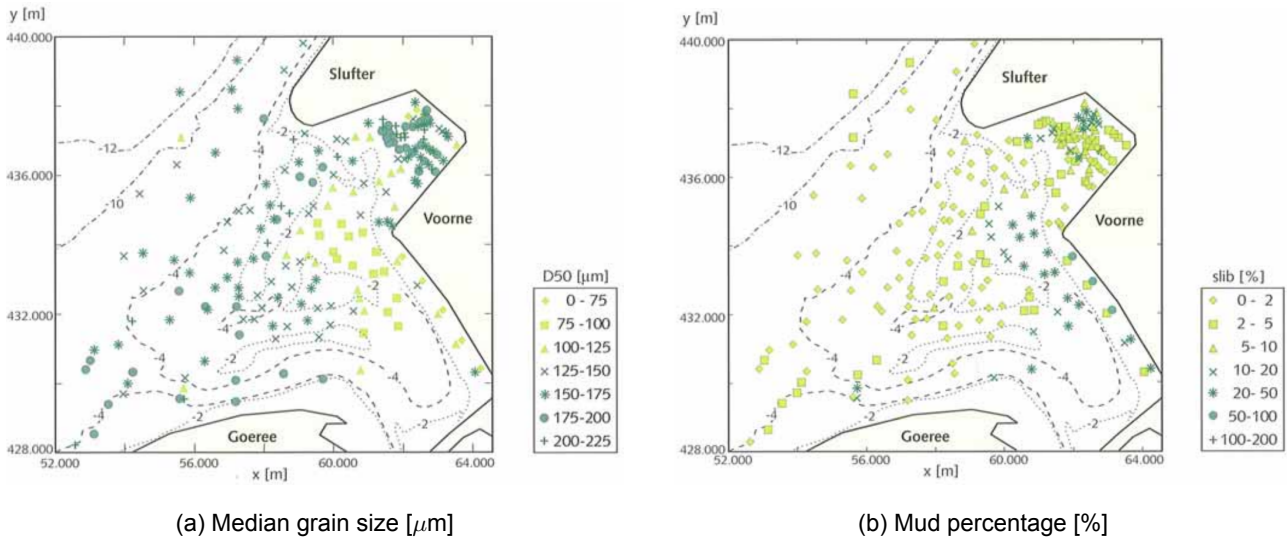

Figure 3.8: Measurement campaign results in the Haringvliet mouth of the median grain size (a) and the mud percentage (b) in 1998 (van Vessem, 1998).

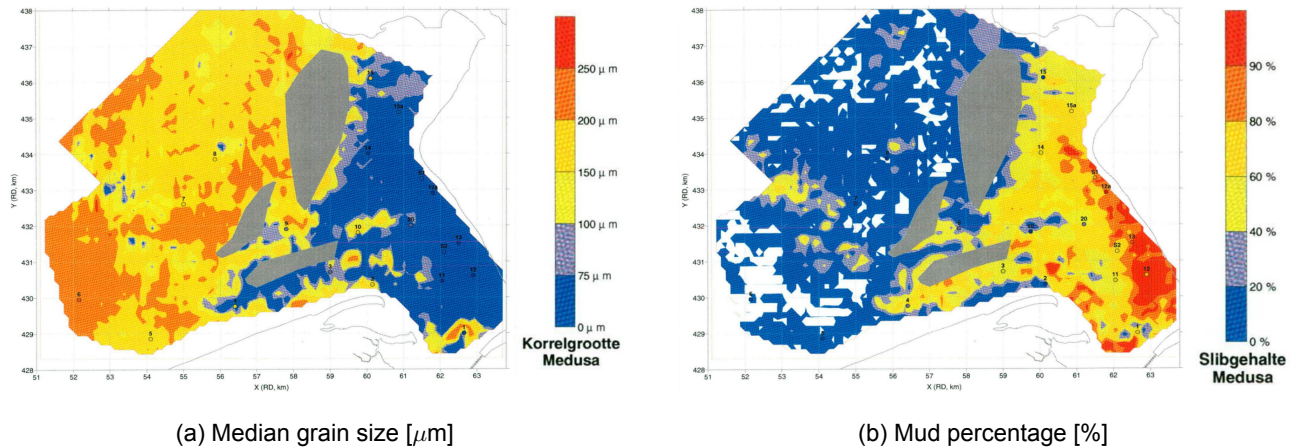

Figure 3.9: Measurement campaign results in the Haringvliet mouth of the median grain size (a) and the mud percentage (b) in 2001 (Koomans, 2001).

These are the most recent extended measurements, but recent studies by (Arcadis, 2022) have indicated in a lower extent that the mud content in the tidal lake has increased. Especially in the eastern part, also in the Brielse gat, the mud content has increased and will do so in the coming years. The cause for this corresponds with the before mentioned driving forces and consequences of human interventions in and around the area. Therefore, a decrease of the median grain size is assumed for this research. A median grain size of $160 \mu\text{m}$ is assumed for calculations and will be further discussed in later chapters.

3.3.3 Sediment transport

The current morphological behaviour in the Haringvliet mouth is dominated by the tide and incoming waves. Due to the sheltered area and accretion of the alongshore and cross shore sediment transport, it is likely that the sedimentation and siltation will increase in the coming years. Several studies (de Vries, 2007; Elias et al., 2016; Colina Alonso, 2018; Arcadis, 2022) have indicated the morphological development of the past years and indicate how this will continue. It is assumed that the current sand banks such as the Hinderplaat will migrate to shore and develop a less dynamic tidal environment. This may result in siltation of the area with an increasing mud content, similar to what happened

to other estuarine areas such as the Eems-Dollard (Cleveringa, 2008), where a large tidal area is subjected to a low dynamic tidal forcing and decreasing over time. This results in excessive siltation of small incoming mud grains.

3.4 Concluding remarks

Based on the discussed elements in this chapter, conclusions can be made, which allows to answer the second research sub-question. The question is repeated below:

What is the qualitative morphological development in the tidal lake of Delta21 and what hydraulic components contribute to this development?

The morphological development in the Haringvliet mouth (the tidal lake when implementing Delta21), is influenced greatly by previous interventions, such as the closure by the Haringvliet barrier and the extension of the port of Rotterdam. The main drivers for sediment transport are the cross shore transport, the alongshore transport, dominant from southern to northern direction and the tidal inflow and outflow. The tidal propagation through the Haringvliet mouth has changed drastically and many tidal channels have sedimented as a consequence of the blockage of the alongshore transport by the Maasvlakte and the blockage of the tidal flow by the Haringvliet barrier. The cross shore transport by sea waves, together with the tide, are strong drivers at the moment. This results in a dominant landward sediment transport direction.

When implementing Delta21, the dominant drivers of sediment transport change with respect to the present-day situation. The influence of waves from open sea is assumed negligible as the dam structure of Delta21 shelters the tidal lake. Therefore, the main hydraulic components that result in sediment transport are the in- and outflow of the tide and the river discharge. The influence by wind consists only of locally generated wind waves in the tidal lake, which effect is insignificant with respect to the tide and river discharge. Within the channel, sediment transport is mainly influenced by high velocities of tidal flow and river discharge. In the present-day, the main morphological developments are forced by cross-shore wave forcing and alongshore transport. These developments will not continue when the Delta21 project is implemented, due to the absence of cross shore directed waves from open sea and blockage of alongshore sediment transport at the southern side of the dam and storm surge barrier of Delta21.

Changes in hydraulic drivers will change the morphological development. Ebb and flood currents in the tidal lake will increase, because the inlet of the estuary drastically decreases to a width equal to the opening of the storm surge barrier. This enhances a significant increase of currents velocities through the channel. The changes in the velocity field result in an increase of erosion and sedimentation in the channel, which may hinder the navigability in the channel and may change the orientation of the channel. Orientation especially changes at bends, due to possible meandering. The remaining (northern) part of the tidal lake is subjected to the change in flow direction and magnitude as well. The tide flows from a different direction through the tidal lake and results in large flow differences in the tidal lake. Large velocities will occur in the channel and relatively low in the northern part of the tidal lake. This enhances sedimentation in the northern part of the tidal lake.

4 Channel design concepts

Considering the functions and requirements determined in Chapter 2, channel concepts are set up in this section to be implemented in the tidal lake. Three concepts are considered for this research, including the current configuration of the Slijkgat. The two newly determined concepts adhere to the design requirements and are supposed to be an improvement on the current channel. The requirements mainly restrict the dimensions of the cross-section of the channel. Specifics on the dimensions are explained elaborately in Appendix A.

First, this chapter explains a few starting points and characteristics for determining the design concepts, which include the cross-section and a few additional design considerations. Next, the design concepts of the channel are discussed. Section 4.2 discusses the current Slijkgat, whereas the two new concepts are described in Sections 4.3 and 4.4.

4.1 Starting points for the design

This section explains characteristics and additional dimensions, which hold for the design concepts and are necessary beforehand. These starting points are characteristics to consider for determining the orientation of the channel concepts. Besides the orientation, this section discusses the possible required bend width to be added to the channel width and the cross-sectional area of the concepts.

First, for determination of the new channel orientations with respect to the current Slijkgat, the following characteristics are considered and explained:

- Velocity gradients along the channel result in unwanted sedimentation at locations where the flow decelerates. These gradients mainly occur at local changes in cross-section and bending of the flow in bends. A straight channel with evenly cross-section along the channel, may decrease sedimentation. Erosion may be enhanced, but the picked up sediment will settle less at locations along the channel.
- The presence of a bend results in local velocity gradients, bending of streamlines and additional helical flow. In addition, for navigability manoeuvring may become more difficult. In terms of morphology, bends usually result in more sediment transport than straight sections, assuming similar flow velocities. Absence of a bend would enhance a gradual flow through the channel and decrease sediment transport.
- The length of the channel has an effect on the guidance and discharge of the flow. A short (and straight) channel allows the discharge to flow within a shorter period of time from, in this case, the Haringvliet sluices to the spillway. This characteristic goes hand in hand with the previous two, but is worth mentioning due to the slightly different application.
- Nature preservation is taken into account in the requirements and as a criteria and should therefore be considered. In this case it is preservation of the intertidal area and sand banks outside the Slijkgat. Therefore, in terms of preservation it is favourable to design the channel within the orientation and location of the current Slijkgat as much as possible. This in contrast to elements of the other characteristics.

4.1.1 Added bend width

The presence of a bend requires a local additional width, in order to cope with sailing corrections and manoeuvrability. It depends on the radius of the bend if such an addition is required. The bend width is calculated by following the guidelines for waterways (Rijkswaterstaat, 2020). For the initial bathymetry, this width at the bend is equal to 4.45 m at the bottom of the channel. The calculation can be found in Appendix A.1. This addition is discussed separately, due to the required bend radius,

which is not considered necessary for each concept. The added width for the new concepts will be given in the next sections if the required radius of the bend is present.

4.1.2 Channel Cross-section

The cross-sectional area of the current Slijkgat after maintenance is presented in Figure 4.1. The required navigable width is met for this cross-section. The depth only holds for mean and high tidal conditions. The slope to the local water depth of the remaining tidal lake differs, because of the different depths along the channel. Therefore, the length and slope are not indicated. Only as a reference, the depth at NAP -2.0 m is indicated. This cross-section does not meet with the required discharge capacity area. Therefore, the new concepts should have a larger cross-section and depth to fit the requirements.

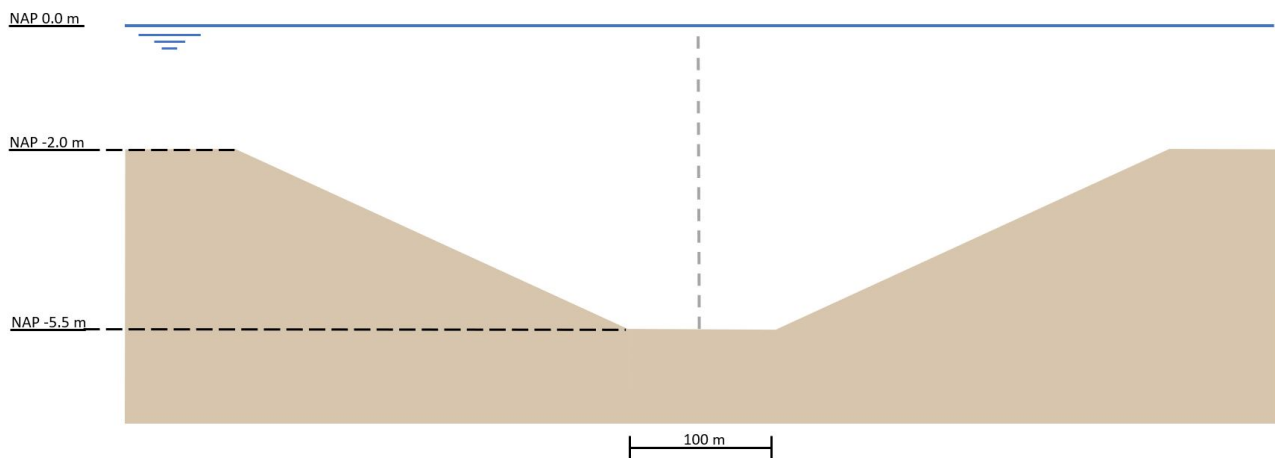

Figure 4.1: Cross-sectional area of the Slijkgat. This cross-section is obtained after maintenance is done. The width from the required depth to the local depth at NAP -2.0 m is not presented, because this may vary along the channel.

The cross-section for the new concepts is chosen the same, due to the strict cross-sectional requirements. Also, a fixed cross-section allows to have a better comparison between the concepts when considering the effects by a different channel orientation. The orientation of the channel is thus the difference between the concepts.

The cross-section of the new channel concepts is determined by considering the requirements and the guidelines of waterways and the PIANC guidelines (Rijkswaterstaat, 2020; McBride et al., 2014). The determined and additional widths by certain forcings for a two way navigation channel are explained in Appendix A. For the discharge capacity function, a cross-sectional area has been defined, which does not allow for excessive flow velocities through the channel for a discharge of 10,000 m³/s. Appendix A.2 prescribes to implement a channel cross-sectional area between 4000 and 5000 m². The calculation of the channel depth results in a depth at NAP -7.0 and the calculation is given in Appendix A.1. Allowing a much deeper channel may enhance further incision by higher flow velocities and narrowing of the channel width as a consequence. Therefore, the calculated depth is chosen as the minimal design depth. Implementation of this depth results in a wide channel to reach the favourable area. The design width of the inner channel and outer channel therefore exceeds the calculated navigable width (73.3 m), including the added bend widths. A width of 200 m is chosen for the inner channel, from which it gradually (over 100 m) decreases to a depth of NAP -6.0 m. From the latter level, the depth gradually proceeds to the local bed level. This with a slope of approximately 1:20, to reach the favoured cross-sectional area. Figure 4.2 shows a schematic representation of the cross-section of the channel. The normative cross-section, where the local surrounding depths are most shallow are displayed in the figure. The widths are given until the NAP -6.0 m boundary, because the slope and length to the local depth may vary. The necessary cross-section for navigability

is indicated as well in order to compare with the required cross-section for the discharge capacity. The cross-section presented below is implemented for both Channel Concept 1 and 2.

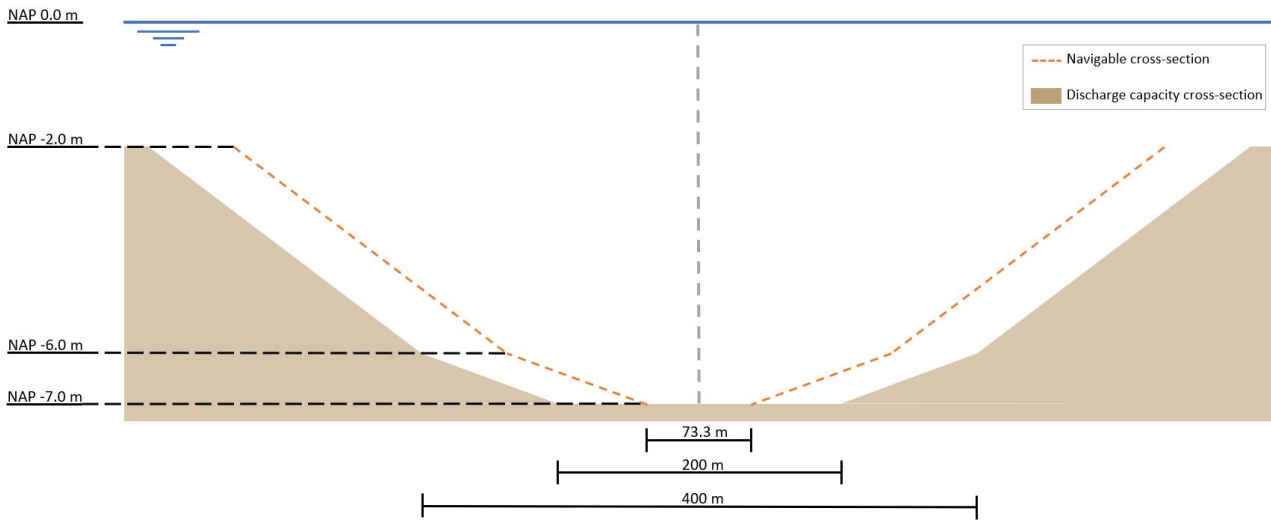

Figure 4.2: Cross-sectional area of the channel concepts. Reference water level is at NAP 0.0 m and the normative cross section with surrounding flats at NAP -2.0 m is chosen. The length and slope from the NAP -6.0 m boundary may vary locally and is therefore not presented. The necessary cross-section for navigability is indicated by the dashed profile.

4.2 Initial Bathymetry

The first concept is the initial or current bathymetry of the navigation channel in the tidal lake. As mentioned in the previous chapter, the Slijkgat has changed in orientation and bathymetry in the past years and requires repeated dredging to allow for navigation. Figure 4.3 shows the contour of the Slijkgat schematically. The navigable widths are smaller in real life than this contour, but the channel is defined within these boundaries. Also, the channel already closely interacts with the increasing Kwade Hoek, which is an unfavourable development. The channel does not fit the newly set up requirements entirely, because the current Slijkgat cannot discharge $10,000 \text{ m}^3/\text{s}$. Nonetheless, mainly as a reference, this concept is considered in this research. Therefore, it is implemented in the modelling study and the accompanying calculations.

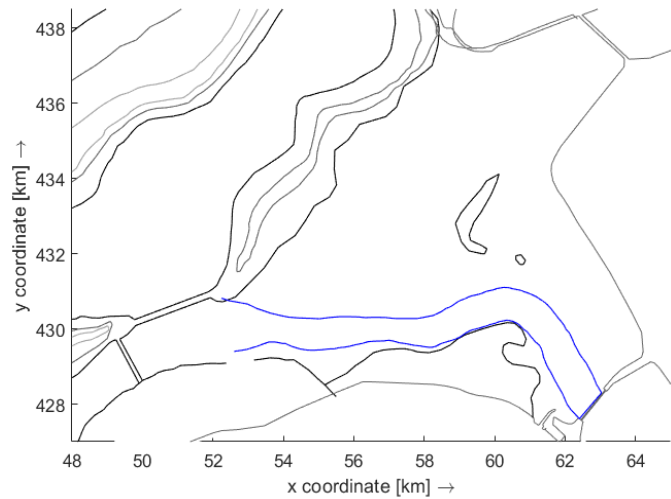

Figure 4.3: Blue contour of the Slijkgat orientation and location in the tidal lake.

4.3 Channel Concept 1

The first channel concept is an adjustment on the Slijkgat. It takes into account a part of each of the defined characteristics. Therefore, the adjustments to the current bathymetry are not major at first sight. The contour of the concept is schematically shown in Figure 4.4

The bend of the Slijkgat partially remains, but has been straightened slightly. The western part of the bend is changed and does now follow a straight orientation to the spillway and storm surge barrier. The eastern part of the bend remains the same. The straightening between the bend and the spillway slightly shortens the length of the channel and allows for lower velocity gradients in the channel by taking out the bending of the flow by the orientation. Construction of this channel results in disappearance of part of the sand banks, mainly of the Hinderplaat, which is disadvantageous for nature preservation. Still, the concept is designed to have a minor impact on the disappearance of nature. The added bend width of this concepts is equal to 3.51 m. As expected, this addition is insignificant with respect to the chosen width by the discharge capacity requirement. Therefore, this addition is not implemented at the bend.

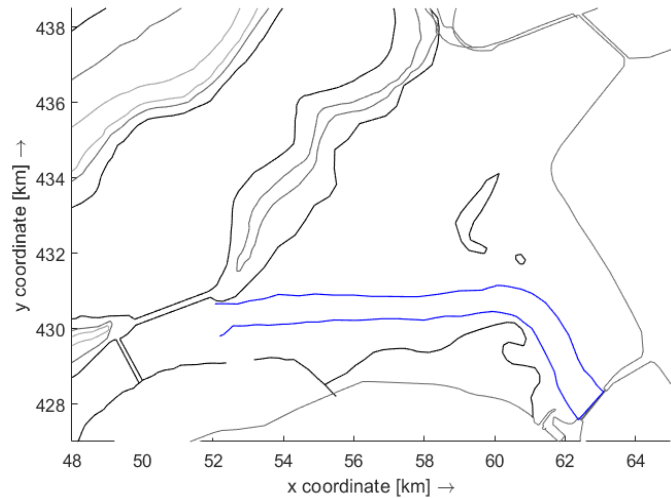

Figure 4.4: Contour of Channel Concept 1, where the orientation and location in the tidal lake is indicated.

4.4 Channel Concept 2

The second channel concept takes into account the defined orientation characteristics as well, but the application is major compared to Channel Concept 1. See Figure 4.5 for the schematically presented channel contour and location in the tidal lake.

The bend has been straightened almost completely for this concept. The channel nearly follows the shortest possible path between the Haringvliet sluices and the spillway. This has been chosen to remove the effects by a bend in a channel and the bend radius is therefore increased greatly. So, computation of additional width is not applicable for this design, also due to the application of the cross-section, defined in the previous section. The flow through this channel will be more gradual and is supposedly accompanied by lower velocity gradients along the channel. In terms of nature preservation, this concept is unfavourable to construct. The Kwade Hoek will almost fully disappear when constructing this channel. It is a concept with major differences compared to the Slijkgat.

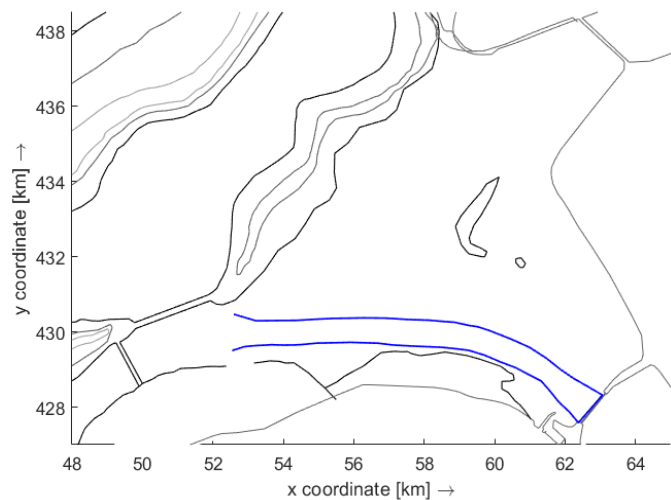

Figure 4.5: Contour of Channel Concept 2, where the orientation and location in the tidal lake is indicated.

5 Morphological model setup

This chapter discusses the specifics of the Delft3D model and the input of the model that is used for this research. First, an introduction of the model is given in Section 5.1. In the next sections, the specifics of the model are discussed, which are divided in grid and bed composition, boundary conditions and calibration and validation of the model. The final section elaborates more on conditions that characterise certain modelling scenarios, which are given as well.

5.1 Introduction

The modelling study for this research is executed by using a Delft3D-FLOW model. Delft3D-FLOW is a multi-dimensional (2D or 3D) hydrodynamic and transport simulation program which calculates non-steady flow and transport phenomena that result from tidal and meteorological forcing. The calculations are executed on a boundary fitted grid, either rectilinear or curvilinear (Deltares, 2021). The model is capable, among other things, to carry out simulations of flow, sediment transport, waves and morphological development.

The hydrodynamic forcings are specified at open boundaries. The type of open boundary is in the form of a water level, velocity, water level gradient or discharge. The forcing type of these boundaries can be of an astronomic, harmonic, QH-relation or time series nature.

For this research, a previously developed Delft3D-FLOW model is used, which has been applied in several studies (Van Holland, G., 1997; Roelvink, 1999; Steijn et al., 2001; de Vries, 2007; Colina Alonso, 2018; Zaldivar Piña, 2020). The model is a 2D model and is adjusted over the years to satisfy the different boundary conditions that apply for the specific study. Also for this research certain boundary conditions are different as input in the model, for instance the Delta21 design. Still, most conditions remain and give the opportunity to validate the model by comparing to the previous studies and apply the performed calibrations by these studies. Performing calibration and validation is a crucial step in the model setup in order to obtain valid results.

5.2 Modelling grid

The Delft3D model and in particular the FLOW-model that is used, calculates over a curvilinear staggered grid. In case of a staggered grid, it depends on the type of parameter at which location the parameter is calculated. A water level is calculated in the centre of a grid cell, the velocities in the centre of the sides of a grid cell and the depth at the corners of the grid cell. This means that a fine grid is required at key locations in order to obtain the different parameters at somewhat the same location. The grid should be large enough to prevent disturbances at the boundaries to entering the area of interest. Nonetheless, there is an optimum for how fine the grid should be, as a finer grid increases computation time. So, an adequate resolution of the grid has been implemented, which has a reasonable computation time. The grid spans a few kilometers over the North sea, (see Figure 5.1). The grid has been refined for previous studies around the Maasvlakte and the Haringvliet mouth. This explains the refined span that intersects at the Maasvlakte and the fine grid cells in the Haringvliet mouth. To give an indication of the size of the cells; the area of the cells at the offshore boundary (not refined) are of the order of $600 \times 600 \text{ m}^2$ and in the tidal lake $50 \times 50 \text{ m}^2$. The Haringvliet river part has a medium fine grid over the length of the Haringvliet, from the Haringvliet barrier until the upstream boundary. This feature is contained for this research, because of the impact of the upstream discharges that are of importance for this modelling study. The size of these cells range from $70 \times 100 \text{ m}^2$ to $300 \times 550 \text{ m}^2$ over the length.

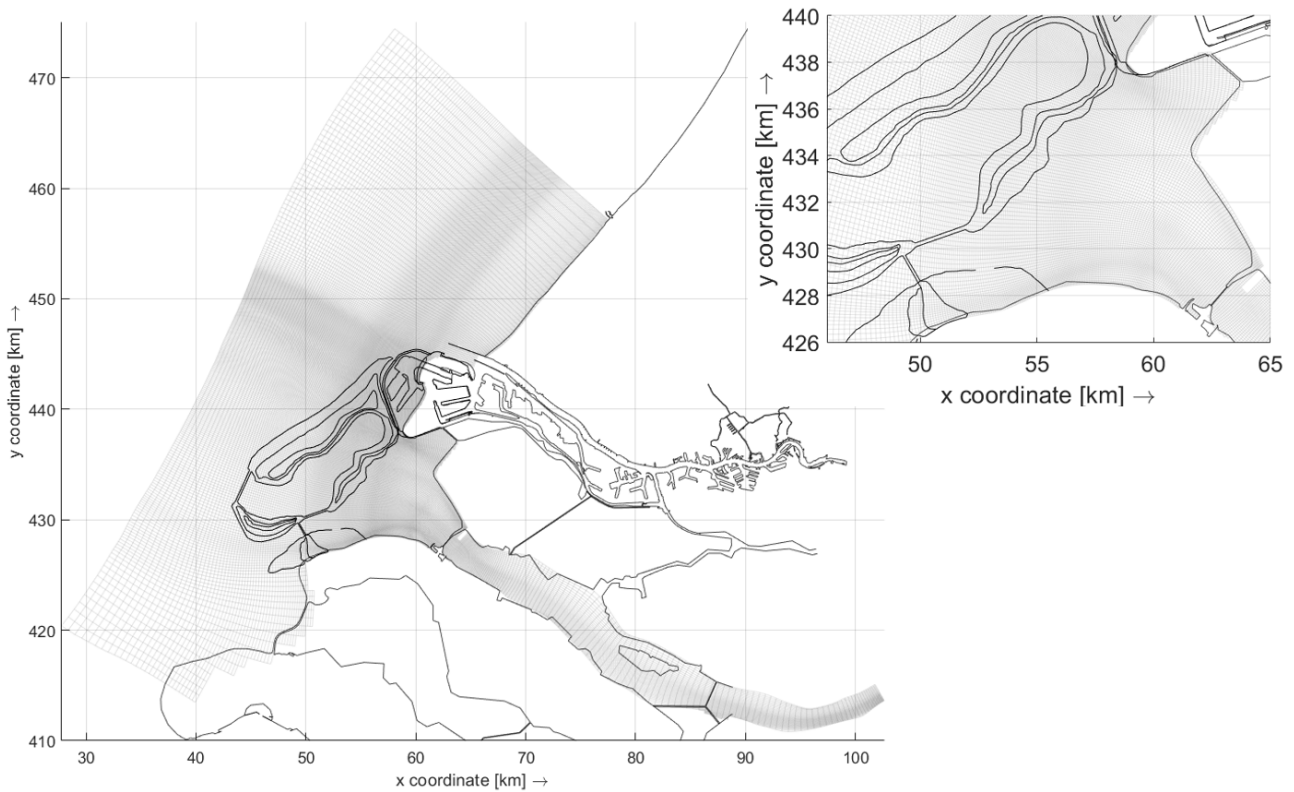

Figure 5.1: Computational grid for the Delft3D model.

During extreme discharge conditions, the storm surge barrier is closed and the spillway open. For this situation an adjusted computational grid is used (see Figure 5.2). This grid is a small part of the original grid, for which the tidal lake area is selected only. The grid cell sizes are kept the same as before. The reason for using this grid is twofold:

- The boundary at the seaside is positioned at the spillway and no tidal forcing is applicable in this case.
- The computation time is much shorter as for the original model, due to the absence of many (irrelevant) grid cells.

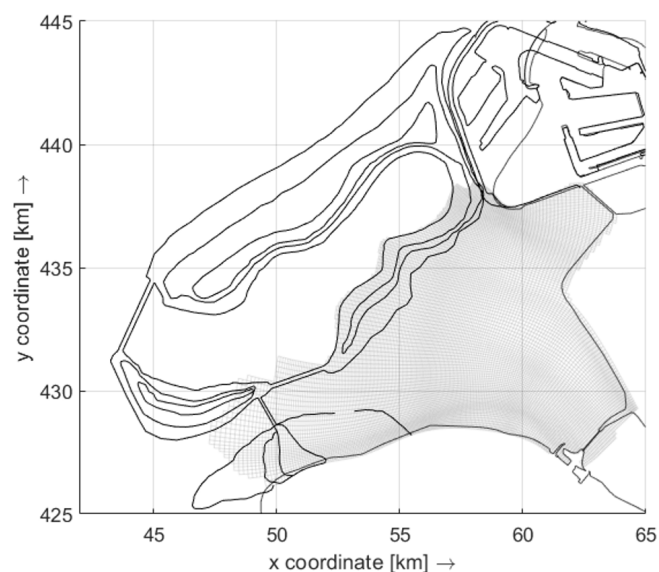

Figure 5.2: Adjusted computational grid for extreme conditions

5.3 Bed schematisation

The bathymetry as input for the model has been setup by use of the Vaklodingen dataset (Rijkswaterstaat, 2022b), which consists of depth measurements along the Dutch coastline. These measurements are collected for certain areas and may vary in when they were acquired. The most recent data and older data with relatively the best resolution are selected to obtain the total bathymetry. The range in years of measurements per area varies between 2012 and 2021. By applying triangular interpolation, grid-cell averaging and smoothing on the curvilinear grid in Delft3D, a gradual and accurate bathymetry is obtained of the coastal area, including the tidal lake. For the remaining bathymetry, upstream of the Haringvliet barrier, the data gathered by Zaldivar Piña (2020) is used. These are measurements of the year 2016 (Rijkswaterstaat, 2020). These measurements have been integrated in the total bathymetry by the same method as for the Vaklodingen data.

Two different bed schematisations have been applied for the model:

- *Normal yearly conditions:* This is the above mentioned current bed that covers the entire original grid and is influenced by the tide and river discharge.
- *Extreme conditions:* This is the bed after one year of modelling and is maintained by dredging to the required channel bed level. The reason for this is the assumption that in the first year there will relatively be more morphological changes due to the large disturbances in the area. Therefore, to model for a more normative bed composition, the maintained bathymetry after 1 year of modelling is chosen.

The Delta21 project is implemented in the bed as well. The design by (Van Eeden, 2021) is used and the corresponding heights of the soft structures are implemented in the bathymetry. Especially the seaside structure is of importance, because there is a local transition of 40 m of depth over 2 km. In order to have a gradual transition, the same slopes of the profile of the soft structure of Maasvlakte 2 is used for this project. This effect on this area is not important for the tidal lake, but because of the large transition, will prevent difficulties for the model calculations. The hard structures; storm surge barrier, spillway and pumping station are schematised by thin dams, surrounded by dry points at the outer points to indicate the transition to the soft structure. The result of the composed bathymetry, implemented by Delta21 is given in Figure 5.3, where the bathymetry of the yearly normal conditions is shown.

The bed in the model consists of one layer of sediment. The initial amount of sediment per cell under the bed level consists of a fixed thickness that can be eroded when calculations are performed. This fixed layer is set on 20 m as input. The model thus allows a maximum erosion depth of 20 m under the bed level per grid cell. Modelling tests of one year resulted in erosion pits around 15 m. So, to account more for extensive erosion, the 20 m thickness is applied.

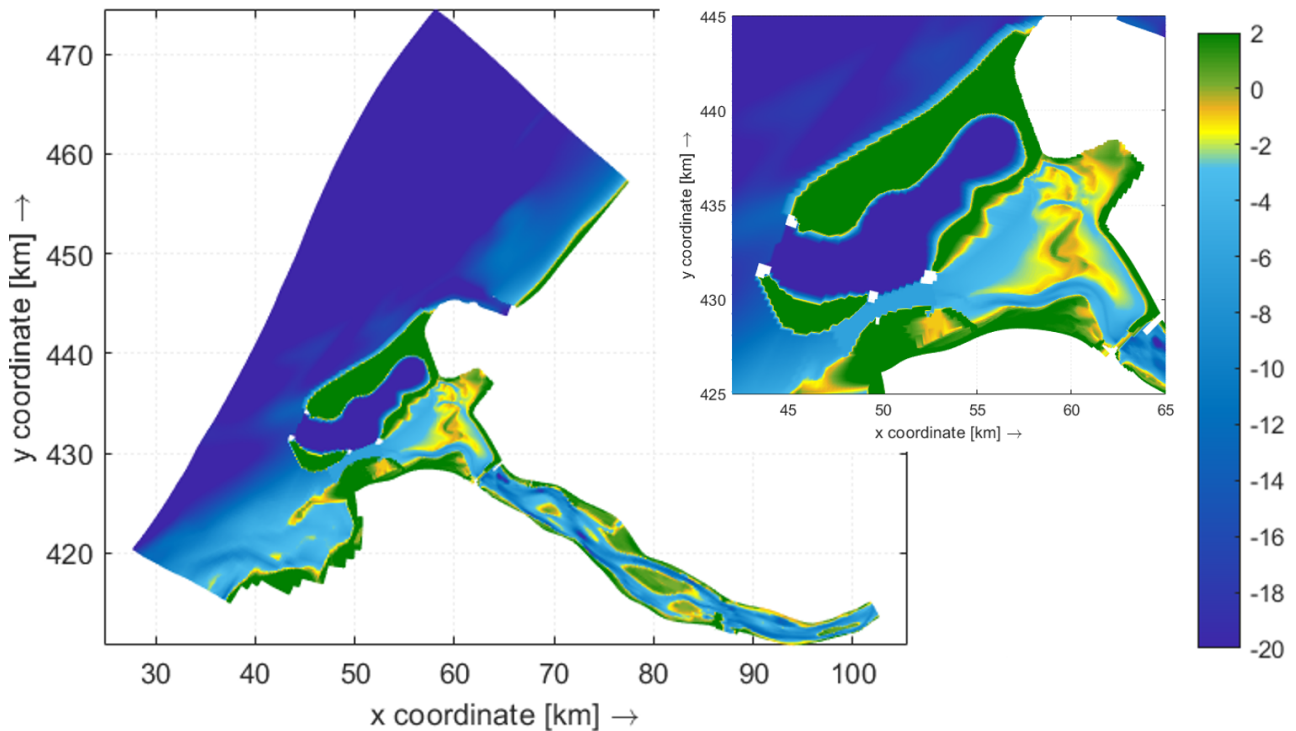

Figure 5.3: Initial Bathymetry for the yearly normal conditions, including the Delta21 project. A close up is given of the area of interest; the tidal lake.

The bed material that is used as input for the model is based on the presented bed composition in Section 3.3. The bed composition contains mainly small grained sand and a small amount of mud. Therefore, the effect of mud is not considered significant for this study due to the majority of sand. Most recent studies (Colina Alonso, 2018; Zaldivar Piña, 2020) have not included the mud content either in the model and have applied a median grain size (D_{50}) of $160 \mu\text{m}$ for each grid cell. Including mud in the model requires knowledge on the initial mud concentrations, which are not available in detail for the simulation period and the area (Colina Alonso, 2018). Also, the bed of this model consists of one layer, which means that the layer has either sand properties or mud properties for each grid cell. A total difference in properties from one grid cell to another results in a complex one-layer model and may not necessarily result in a representative bed. A different property is for instance the cohesiveness of mud, which requires more complex computations. Therefore, the mud content is omitted in this model. The chosen median grain size of $160 \mu\text{m}$ is slightly smaller as the median grain size of sand in the area, in order to implement the smaller grain size of mud.

Bed protection

Key elements in the Delta21 plan are the storm surge barrier and the spillway. These constructions rely on minimum bed levels in front and behind them, where bed protection prevents eroding below these minimum levels. Such a non-erodible bed protection area is implemented in the model in order to represent the real situation. First, a sensitivity run was performed without the bed protection to determine the initial state of the tidal lake and to see what would happen without bed protection in terms of velocities, erosion and sedimentation. Next, for the bed protection there are two different protections; at the spillway and the storm surge barrier. For the spillway, the bed protection designed by Donkers (2021) is implemented in the model. However, this spillway was integrated in a previous Delta21 design, with a deeper local depth for the bed (NAP -10 m). For the new Delta21 design, the local bed is around a level of NAP -7 m. Therefore, the bed protection at the spillway is set to NAP -7 m too. This in order to have a smooth connection between the bed protection level and the surrounding bed levels and to accommodate the transition with the channel concepts, which bed level is the same as for the spillway. The length of the bed protection is around 450m from the spillway, which

length will be implemented roughly in the model as well.

The bed protection of the storm surge barrier has not been designed yet. To still get a feeling of what can be assumed in the model, bed protections of similar structures in the surrounding area are considered, for instance the Haringvliet barrier and the Eastern Scheldt Barrier (Rijkswaterstaat, 1986a,b; Blokland et al., 1970). Both barriers are considered and do resemble the sill depth that will likely be applied for the new storm surge barrier. It turns out, by performing first verification runs in the model, that relatively high velocities (order of 1.5-2.2 m/s) occur around the storm surge barrier under normal tide conditions. These velocities come close to the velocities that occur at the Eastern Scheldt Barrier (Eelkema, 2013), although still larger than the latter. Of course these velocities also occur for the Haringvliet barrier, but not under normal conditions. Therefore, a similar rough implementation of the Eastern Scheldt Barrier bed protection will be used in the model. This results in an approximate bed protection length of 600 m at each side of the barrier. The sill depth is set at NAP -6 m, which corresponds more with that of the Haringvliet barrier. The remaining bed protection level is set to NAP -8 m after the gradual transition from the sill to the surrounding bed level. An impression of the bed protection at the spillway and the storm surge barrier, which will be the input for the model, is shown in Figure 5.4.

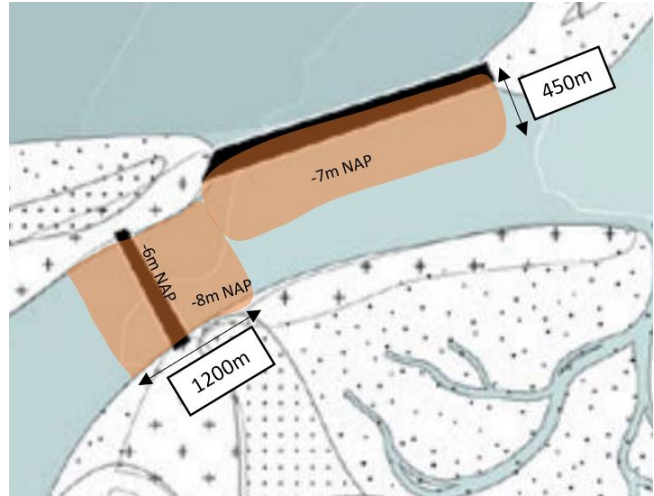

Figure 5.4: Bed protection impression as model input. The lengths indicated by arrows are approximate rounded values. (Adjusted from: (Van Eeden, 2021))

Implementation of adjusted layout of new storm surge barrier in Delft3D

Another spatial variable input in the model is the length of the storm surge barrier and thus the width of the tidal lake inlet. The initial length of the barrier, indicated by Van Eeden (2021), is around 750m. Depending on the type of barrier that will be designed, this is the maximum width of the inlet. When for instance several gates with pilars in between are chosen for the design, the effective width will be smaller. A narrowing results in higher velocities and may cause significant erosion pits. Therefore, a spatial variant in the model could be to lengthen the barrier and thus inlet width, in order to obtain locally lower velocities, which could result in a more constant flow in the tidal lake (channel).

A similar cross-section as for the Haringvliet sluices is chosen to obtain the lengthening. The sill depth is chosen slightly deeper with respect to the Haringvliet sluices (0.5m difference). With a similar length, the inlet at the storm surge barrier is slightly larger as the Haringvliet barrier. The Haringvliet sluices have a total width of 1048.5m, including pilars (Blokland et al., 1970). So, the new effective length of the storm surge barrier will be set to 1000m. Assuming the sill depth at NAP -6 m, the effective cross-sectional area of the inlet with respect to NAP 0 m increases from 4500 m² to 6000 m².

5.4 Boundary conditions

5.4.1 Flow boundary conditions

The Delft3D FLOW-model is bounded at the ends of the grid, where at a few ends open boundaries are applied, which are imposed by flow conditions. The remaining ends are land boundaries. For the open boundaries, three types of boundary conditions could be applied; water level, Neumann (water level gradient) and discharge. The model boundary conditions have been derived and validated in previous studies (Roelvink, 1999; Steijn et al., 2001; de Vries, 2007) and are adopted in further studies as well (Colina Alonso, 2018; Zaldivar Piña, 2020).

Water level boundary

The seaward boundary is a water level boundary, where the tidal signal is imposed harmonically. This results in the tidal forcing in the modelling area. This water level is imposed harmonically as the amplitude of tidal components and the water level setup. Eq.(5.1) describes the water level determination that is imposed on the alongshore boundary.

$$\xi(t) = A_0 + \sum_{i=1}^n A_i \cos(2\pi f_i t - \phi_i) \quad (5.1)$$

Where:

$\xi(t)$: water level elevation at the boundary at moment t

A_0 : mean water level over a certain period

A_i : local tidal amplitude of harmonic component i

f_i : frequency of harmonic component i

ϕ_i : phase of harmonic component i

The input for determining the amplitude as a result of the tidal components has been derived by previous studies as well (Roelvink, 1999; Steijn et al., 2001). A schematisation of the tidal cycle has been setup in order to construct a suitable morphological tide. This tide is constructed out of eight tidal components, with M_2 and M_4 components being the most dominant. This morphological tide has a period of 12 hours and 24 minutes and the derived tidal cycle has a tidal range of 1.91m. This input of the tide has been applied in several studies and will therefore be implemented for this research as well. The tidal propagation through the tidal lake is a separate step in the modelling study, both to validate the propagation with previous studies and to obtain hydrodynamic results through the tidal lake with a dominant tidal forcing.

Neumann boundary

The modelling area at the northern and southern ends is imposed harmonically with a Neumann boundary. This type of water level gradient boundary is used for cross-shore boundaries in combination with a water level boundary at an alongshore boundary, in this case the seaward boundary of the model. A Neumann boundary is meant to overcome difficulties by the alongshore water level gradient at the northern and southern boundaries. The main difficulties originate from the tidal input at the alongshore boundary, so the gradient varies only with the tide along the coast. The Neumann boundary was first implemented in the model by de Vries (2007) and is applied on subsequent studies.

Upstream river boundary

The upstream river boundary is situated near the transition between the Haringvliet and Hollands Diep. As input for the model, a time series is implemented of a specific discharge year. This time series is calculated at the Haringvliet sluices, as is discussed in Section 3.2, to obtain a good approximation of the implementation of the Kierbesluit (Noordhuis, 2017). The data at the Haringvliet barrier is applied to the discharge boundary in order to take into account the Kierbesluit more accurately. For instance by including the zero discharge values when the sluices are closed. Also, the discharge at the boundary allows for less spin-up time in the model at the Haringvliet sluices due to the large distance.

The data that is used is calculated data at the Haringvliet sluices (Rijkswaterstaat, 2022a), which is a human-driven mechanism, where many times the sluices are closed. This has resulted in many zero-measurements. Due to the human-driven mechanism, the calculated data is complicated to be described by a distribution or applicable in other statistical analyses to setup a representative year of discharge. Also, due to the large deviation in the discharge data and the fact that it is not known beforehand what discharge is normative for the long-term morphological development (relatively high or low discharges), three years are chosen as input for the model. A selection based on sediment transport has been carried out in order to relate to the morphological response in the tidal lake. For this, discharge years which results in maximum, minimum and mean sediment transport are selected (see Figure 5.5). The degree of sediment transport has been carried out by considering the discharge through the Haringvliet sluices over a constant cross-section, which results in a velocity through the sluices. The bed-load and suspended sediment transport in the model is among other parameters described by a velocity to the power 2.5 and 3.4 (Van Rijn, 2007a,b). More on the transport formula will follow in the next paragraph.

The higher order velocities from discharges have been calculated for all discharge years separately. These are compared with the total discharge data of all years combined. The mean discharge year has been selected by considering the mean of the total discharge data (green line in Figure 5.5). This discharge year is the year 2018. For the discharge years that result in maximum and minimum sediment transport, the years 1994 and 2014 are assumed respectively. To give an overview, Figure 5.6 shows the three discharge years. Please note that the previously mentioned threshold of $7500 \text{ m}^3/\text{s}$ is implemented in the data. These three years will be implemented as input for the model separately for every modelling scenario. This to have a comparison between different discharge inputs and to indicate the effect and dominance of different discharge data as input.

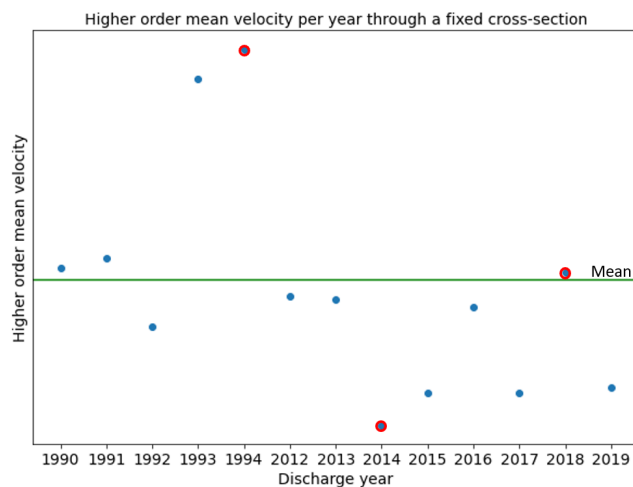

Figure 5.5: Higher order analysis for selecting the maximum, minimum and mean discharge year that result in sediment transport. The selected years are indicated by a red circle.

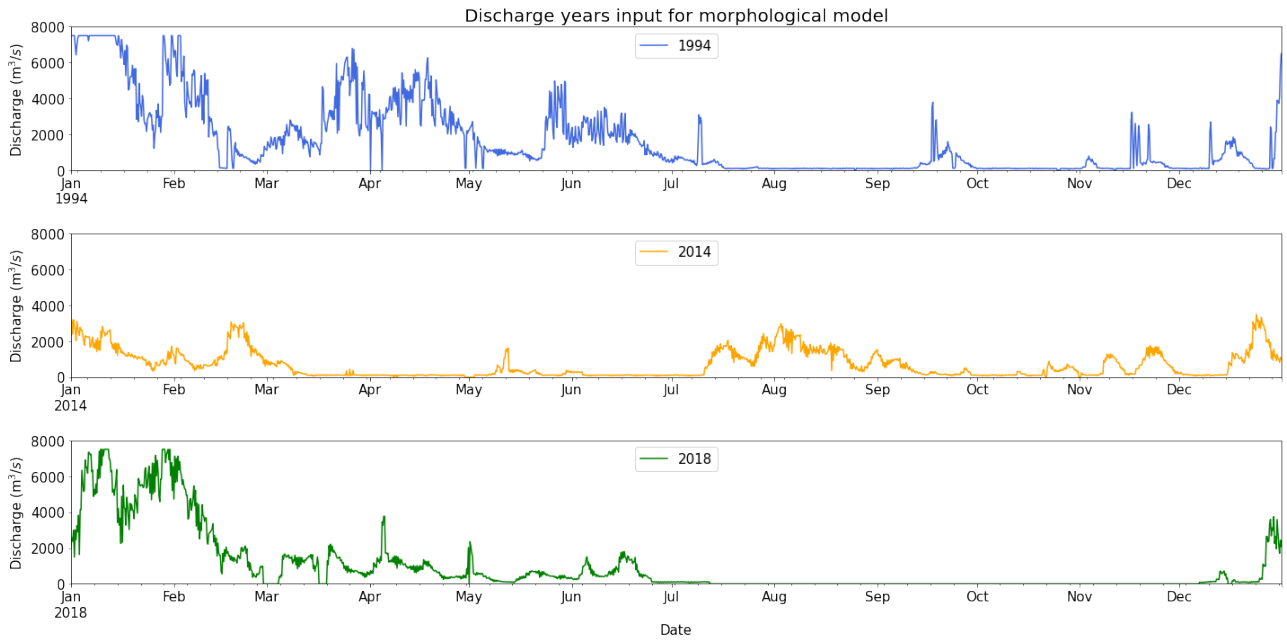

Figure 5.6: Three discharge years as input for the 1 year morphological modelling. The maximum, minimum and mean discharge years are respectively 1994, 2014 and 2018.

Additional analysis on the probability of occurrence of the discharges per discharge year has been carried out as a tool for determining the long-term morphological response of the channel. This has resulted in determination of weighted factors per discharge year to indicate the contribution to an approximation of the total discharge dataset. The full analysis is reported in Appendix D, where the best fit has been constructed, regarding the three discharge years. This fit is given in Figure 5.7 and will be used in next chapters to indicate the long-term morphological response, considering the yearly responses to the individual discharge years. So, the morphological results, assuming the weighted discharge year, are presented in the next chapter.

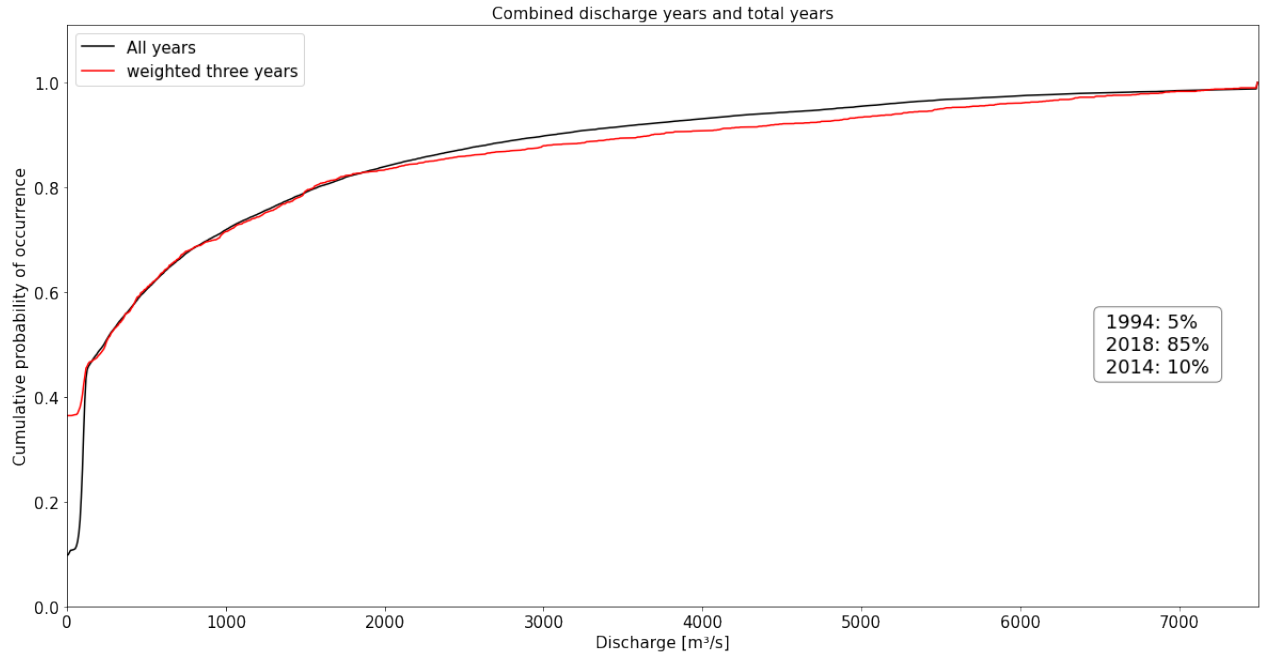

Figure 5.7: Cumulative probability of occurrence of the combined years and the weighted data of the three years. The weighted factors are indicated per discharge year.

For the extreme conditions, the short-term morphological response of a high water wave, assuming a closed storm surge barrier, is of interest. A time span of one week is chosen as a normative long-term high water wave, with a peak of 10,000 m³/s. The storm surge barrier is considered closed, so a starting and ending discharge of 7,500 m³/s is assumed, which gradually increases and decreases to and from the peak discharge.

5.4.2 Morphodynamic Settings

Transport formula

Translating the flow conditions to morphodynamic conditions in Delft3D is done by enabling the SED-module in the model. This allows computations of bed-load and suspended load by the model, considering the hydrodynamic flow conditions. Both bed-load and suspended load transport are computed by Van Rijn (2007a,b). As mentioned before, the sediment transport in the model is schematised by the transport of a median grain size of 160 μm of sand. So, no cohesive properties are included in the input. For bed-load transport in both coastal and river regions, the formula is well presented for a particle size range of 200-1000 μm . These results show good agreement with the laboratory and field data for steady and oscillatory flow. However, for sandy bed-load the transport weakly depends on the grain size. Therefore, the bed-load is still reasonably represented by the formula (Van Rijn, 2007a). Also, Van Rijn showed that for particle sizes smaller than 300 μm , suspended load is much larger than bed-load.

The suspended load is thus relatively larger and should be described well by the transport formula. The suspended sediment transport is determined by using the advection-diffusion equation and computed the time-averaged sand concentration profile for the combined effect of currents and waves (Van Rijn, 2007b). Suspended sediment transport is, unlike bed-load, strongly dependent on the particle size, together with current velocity. The study was executed by particle size data of 60 to 600 μm , and is thus suitable for this research, due to the applied median particle size and the dominant forcing of current velocities in the model.

MorFac

In order to reduce computation time and required storage, a morphological acceleration factor (MorFac) is applied. Implementing such a factor allows to make morphological computations as a result of hydrodynamic conditions over a simulation time, multiplied by the MorFac. For example, a simulation time of hydrodynamic conditions of one month gives morphological results for two months, when applying a MorFac of two. Of course, the morphological results will be less accurate than applying a MorFac of 1. Thus, there is a maximum in the application of a MorFac, which does not result in significant changes over time. For this model, previous studies have applied different MorFac for different simulations (de Vries, 2007; Colina Alonso, 2018; Zaldivar Piña, 2020). The applications by Zaldivar Piña (2020) are assumed most applicable, due to the most resemblance in model input. Considering the results of that research, has resulted in the assumption of applying a MorFac of 10 for the one year simulations. So, hydrodynamic conditions of 36.5 days will be implemented as computation time, accompanied with a MorFac of 10. The time step of the discharge time series has been adjusted to match the applied MorFac and thus attempt to implement the discharges over a year. The tidal signal remains the same due to the oscillatory and repeating property.

Simulation Time

The time step (Δt) that will be used by the model for calculation is equal to 0.5 min. The time step for storing data is chosen larger to decrease required storage. The time step of storing data for every grid cell is set to 30 minutes and that of an observation point, which is an assigned grid cell, the step is set to 4 minutes. The shorter time step at the observation point is selected to have more detailed results at that specific location. A time step of 30 minutes is detailed as well and may require large storage and computation time. However, enough data should be obtained. For instance, to describe

the tidal signal in the channel and the effect it has on other parameters.

5.5 Calibration and validation

The use of a numerical model and the results it generates aims to resemble what happens in reality. It is desired to reproduce the real physical mechanisms when using a model. Therefore, important steps in the model setup are calibration and validation. By calibration, the aim is to tune certain input parameters in order to resemble the reality as close as possible. Validation aims to describe and prove physical phenomena accurately.

Calibration

For this numerical model many calibrations have been carried out by previous studies (Roelvink, 1999; Steijn et al., 2001; de Vries, 2007; Colina Alonso, 2018). Input parameters and formulas have been added or have been changed over the years, for instance the transport formulation, which has been changed to the Van Rijn 2007 formulation. More specifics on the calibration of the model is found in previous studies. In particular the most study by (Colina Alonso, 2018), which adjusted the forcing conditions that resulted in different outcomes in the transport formula and hence the morphological development.

Validation

Just as for calibration, validation has been carried out by the same previous studies. For this research, the validation is based on the studies by Colina Alonso (2018) and Zaldivar Piña (2020). The first, because it is the most recently calibrated model and the latter because of the implementation of Delta21. Many influences and processes are different when introducing Delta21 in the model. Therefore, the main validation is done with the model by Zaldivar Piña (2020). The Delta21 design that was used for the study was different in type of structure and in orientation than for this study. This means that certain validation is considered either more qualitatively or quantitatively only, instead of a perfect resemblance. Validation step results are presented in Appendix C for clarification.

The first validation step was by modelling the tidal forcing only and without Delta21. This resulted in the same velocity patterns and water level change over time at specific locations as the previous studies. Next, with the implementation of Delta21, only a validation with Zaldivar Piña (2020) could be made. The tidal forcing nearly had the same behaviour and damping in and around the tidal lake at key locations as for the implementation of the previous design. This has led to the validation of the tidal propagation through the area of interest. The next validation step was to include the upstream discharge. For this research another discharge time series is setup and implemented in the model, which can therefore not be validated quantitatively. Therefore, only the discharge input by the previous study is implemented and validated on similar hydraulic and morphological outcomes. The morphological response has been compared in a qualitative manner. With the same computation time and input, but a different Delta21 design, similar erosion and sedimentation patterns were obtained. Also the order of magnitude resembled the outcomes, where for this research especially around the storm surge barrier more erosion occurs, which is in line with expectations regarding the narrow transition between the tidal lake and the sea.

5.6 Model conditions and parameters

This section explains the long-term and short-term conditions that are considered for this research. The grids have already been introduced in this chapter, but the specific conditions are explained here further. The relevant parameters from the modelling results are introduced in this section as well.

5.6.1 Normal conditions

The normal conditions are considered to be the long-term conditions that result in average morphological changes over time. The spillway is considered closed and the storm surge barrier open, which is the case for non-extreme conditions. The morphological simulation time is in the order of years, which is interesting for maintenance works. Therefore, simulation times of 1, 5 and 10 years are desired for the normal conditions model runs. However, test runs show that the computation time and especially the required storage of the output is major. For a good balance between calculation time and quality of the results, only a simulation time of 1 year is chosen for the normal conditions.

5.6.2 Extreme conditions

The extreme conditions in this case are considered to be of short-term simulation time with high discharges. This is the situation when the storm surge barrier is closed and the spillway is open to let the tidal lake water flow into the energy storage lake. The high discharge that flows into the tidal lake is assumed to be in the range of 7500-10000 m³/s, for a simulation time of 1 week. Unlike Section 5.6.1, these extreme events have a large morphological impact in a short period of time. The numerical grid that is used was already given in Figure 5.2. The input bathymetry for the extreme conditions is chosen to be the bathymetry after one year of modelling normal conditions. This to have a more stable and representative morphology for the years after construction of Delta21, instead of the initial bathymetry where more morphological changes are presumed yet to happen.

Furthermore, the bed protection and length of the storm surge barrier are implemented as well. An extensive explanation about these two features have been stated before. For these conditions it comes down to the assumption to apply the bed protection as can be seen in Figure 5.4 and the lengthening of the storm surge barrier. The difference in length will not pose much difference in flow as for normal conditions, because there is no tidal flow and a closed barrier.

5.6.3 Model parameters

The presented results of the modelling study should support the answers to the research questions. These will be presented in the next chapter. The parameters that are relevant for this study are introduced in this section, as well as qualitative processes. For each parameter, a motivation of relevance is given as well as how the parameter is determined.

Tidal propagation

The tidal propagation through the tidal lake is modelled for sensitivity analyses and to validate the model. For answering the research questions, the tidal propagation is important to give a qualitative overview of the tidal movement through the tidal lake. To indicate this, two tidal cycles, together with a mean discharge of approximately 1100 m³/s are considered. Such a cycle is chosen in order to indicate the tidal forcing in the tidal lake and to not neglect the influence of river discharge.

Tidal prism

The tidal prism is considered an important parameter when modelling in a tidal basin, in this case an estuary. The tidal prism is relevant for this research, because changes in this parameter may influence the flow and sediment transport in the estuary. Therefore, for each concept, calculations are carried out by the model in order to obtain the change in tidal prism over one year of morphological modelling.

For these calculations, the bed level of the weighted discharge year is used over one year, which is influenced only by the tide. Notice, the change in tidal prism is calculated over 36.5 days. Due to the MorFac of 10, the simulation is representative for a period of 1 year. The tidal prism is calculated at the storm surge barrier, which may be considered as the inlet of the estuary. The storm surge barrier has a constant cross-sectional area over time, which allows changes in velocities over a tidal cycle being translated to change in tidal prism. The tidal prism is computed over a tidal cycle by Equation (5.2) from (Bosboom & Stive, 2021).

$$P = \frac{1}{2} \int_0^T |Q(t, 0)| dt \quad (5.2)$$

Where:

P [m³] : Tidal prism

Q [m³/s] : Discharge through the inlet

T [s] : Tidal period

Flow velocities

The flow velocities in and around the channel concepts are presented in a qualitative and quantitative manner. The qualitative results represent the relevant flow patterns that occur at certain locations at specific moments in time. These patterns are drivers for sediment transport and are therefore important to discuss and to compare between the channel concepts.

The quantitative results are necessary to compare velocity magnitudes with the safety requirements for longitudinal and cross flow through the channel. The requirements state that safe navigation for a discharge with a 10% exceedence probability should be reached. Therefore a quantitative analysis, considering such a probability, is carried out. A tidal cycle from the weighted discharge year is selected, where on average a discharge flows into the tidal lake with a 10% exceedence probability. For the weighted discharge year this is a discharge of 3683 m³/s. Next, for each hour in the tidal cycle, the velocity components are computed for 20 points along the channel concepts. Figure 5.8 shows these 20 points for each concept, including the center line of the concepts. The points are chosen such, that they are as close to the center line as possible. The location of the points depend on the grid cell location. Also, the kilometers along the center line are given, which are used in the analysis and indicate the length of the concepts. The velocity components that are determined, are in longitudinal and perpendicular direction of the orientation of the channel. These components are obtained by local transformation of the coordinate system to the orientation of the channel. As an example, Figure 5.9 is given, where the components per point are adjusted for the initial bathymetry concept.

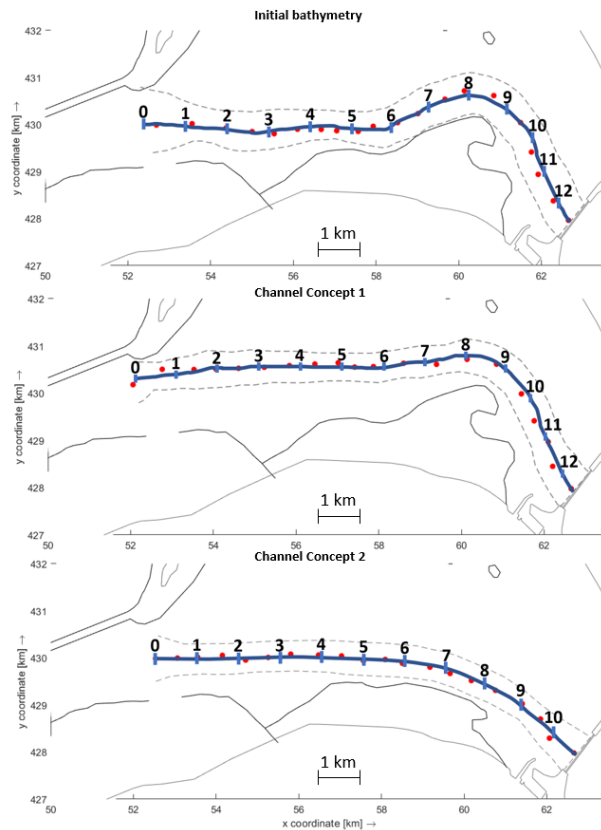

Figure 5.8: Length of the channel concepts along the center line in kilometers [km]. The chosen points for the quantitative analysis for the flow velocities are included in red.

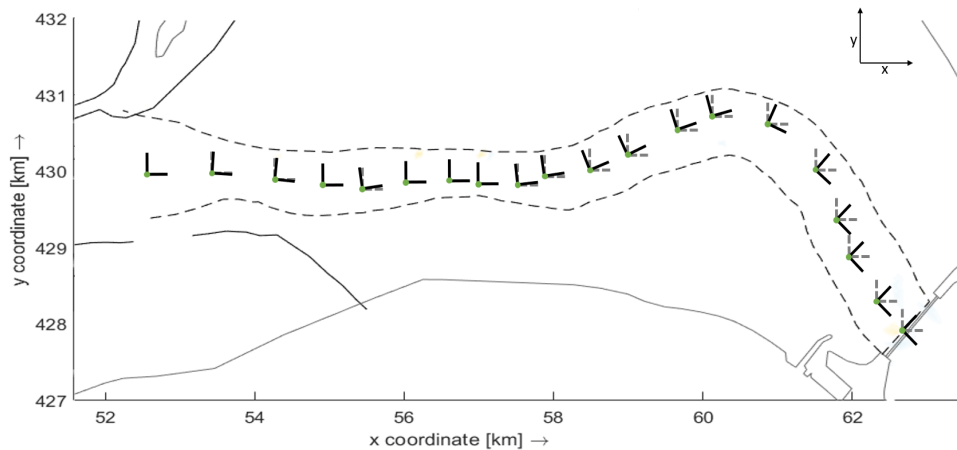

Figure 5.9: Coordinate transformation along the channel, to obtain a longitudinal and perpendicular velocity component for each point. The initial channel is chosen as an example.

Other velocity aspects that should be considered for safe navigability are the spatial velocity gradients along the channel. Especially the cross current velocity gradients are to be taken into account, because sudden (large) changes in cross currents may result in significant cross driving forces on the vessel. The PIANC (2014) report does not indicate precise guidelines for gradients of velocity currents and are thus not to be described in a SMART manner. Therefore, the velocity gradients are not stated in a principal requirement, but are included in the evaluation criteria as they influence navigation safety. The velocity gradient per component is computed as a spatial gradient over the length of the design vessel, which is 135 m. Similar to the velocity components, the velocity gradient is determined per hour between each point along the channels.

Bed level change

The morphological changes over the modelling period are determined as the bed level change in and around the channel. The bed level change is either positive or negative, which can be assigned to erosion and sedimentation respectively. The bed level change is relevant, because it allows for a qualitative and quantitative assessment. Quantitative in the sense that it gives the length of bed level change. Qualitative in order to distinguish certain erosion and sedimentation patterns, which may explain the effect of hydraulic processes in the tidal lake. Additionally, the bed configuration during and after the modelling period can be determined as well with the modelling results.

Sedimentation volumes

Another quantitative parameter from the morphological results is the volume of the change in bed level. Especially the sedimentation volume in the channel is important. The channel has a required depth and geometry that should hold for navigability and discharge capacity. Sedimentation may threaten these requirements, which can be maintained by dredging. Therefore, the sedimentation volume is a useful parameter to determine the required dredging over time. Only the sedimentation above the required navigable depth is relevant for dredging. Therefore, the sedimentation above NAP -7 m is included in the calculations. The volume is determined by multiplying the bed level change by the grid cell area. Adding up these grid cell volumes allows to obtain the volume change in the entire channel, but also of a detailed area of grid cells at relevant locations. For the volumes in the entire channel concepts, a schematised channel is selected, which is bounded by the grid cell size and orientation. The selected grid areas are indicated by the orange contours in Figure 5.10. The channel concepts are given by the dashed contours. The total surface area of Channel Concepts 1 and 2 are similar to each other, which allows comparison of the volume change in the channel. The area of the initial bathymetry is larger, due to the unwieldy shape of the Slijkgat with respect to the grid structure. Still, the relevant sedimentation and erosion falls inside the selected area.

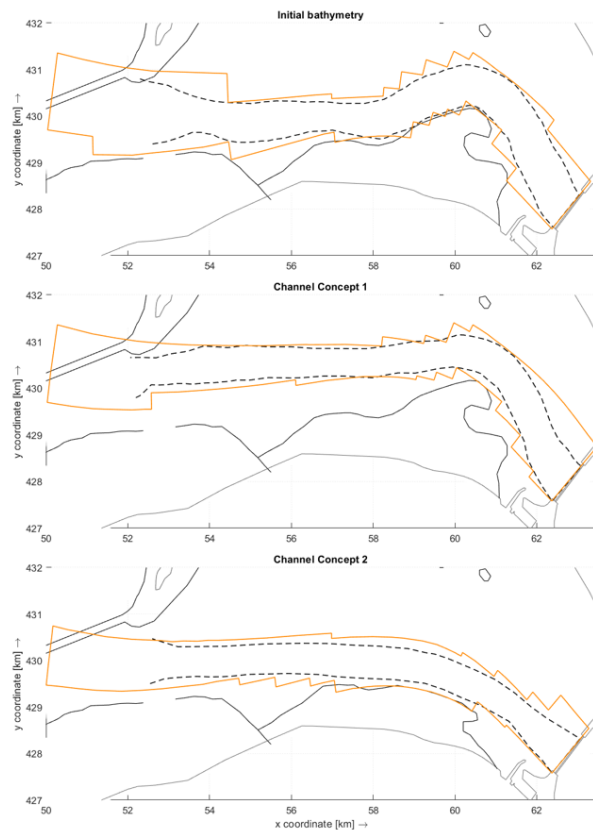

Figure 5.10: Selected grid areas per concept within which the volumes are computed. The concerned volumes are indicated too.

The area of the initial bathymetry is larger, due to the unwieldy shape of the Slijkgat with respect to the grid structure. Still, the relevant sedimentation and erosion falls inside the selected area.

5.7 Model scenarios

The model computations that will be performed in this research follow from the previous sections and mainly from the explanations of the normal and extreme conditions. Scenarios are setup, which are distinguished by the different conditions that apply. To give an overview of these scenarios, Table 5.1 and Table 5.2 are provided. The tables consider the initial bathymetry, where most sensitivity analyses have been performed, and the runs for the two design concepts, which have more distilled conditions to set up applicable model runs. The scenarios are numbered to a total of twelve. The second year runs are not numbered separately. Note that the opportunity for optimisation is considered as a scenario as well. This scenario is optional and the necessity of carrying out the optimisation will follow after evaluation. The tables also indicate a few variable boundary conditions for each scenario, which are; the state of the spillway and storm surge barrier, present bed protection and length of the storm surge barrier.

Table 5.1: Model scenarios (1-8) for the initial bathymetry of the tidal lake. More sensitivity analyses are included in this state.

	Spillway	Storm surge barrier	Bed protection	Initial or long barrier
Normal condition (1 and 2 years)				
1. Tide only	Closed	Open	No	Initial
2.	Closed	Open	Yes	Initial
3.	Closed	Open	Yes	Long
4. Low discharge year	Closed	Open	Yes	Long
5. Medium discharge year	Closed	Open	Yes	Long
6. High discharge year	Closed	Open	Yes	Long
7. Extreme conditions	Open	Closed	Yes	Long

Table 5.2: Model scenarios (9-13) for the bathymetry which are associated with Channel Concept 1 & 2.

	Spillway	Storm surge barrier	Bed protection	Initial or long barrier
Normal condition (1 and 2 years)				
8. Low discharge year	Closed	Open	Yes	Long
9. Medium discharge year	Closed	Open	Yes	Long
10. High discharge year	Closed	Open	Yes	Long
11. Optimisation	Closed	Open	Yes	Long
12. Extreme conditions	Open	Closed	Yes	Long

6 Model results

This chapter presents and analyse the results of the morphological modelling for normal and extreme conditions, using the model set-up of Chapter 5. Section 6.1 discusses the hydrodynamic results for each of the channel concepts. The main parameters are the flow velocities, flow directions and the tidal prism. These results explain the underlying processes for the morphological response and results, which are discussed in Section 6.2. The relevant morphological parameters are the erosion and sedimentation patterns and the sediment volumes.

6.1 Hydrodynamic results

6.1.1 Tidal propagation

The first scenario in the modelling study considers only the tide as hydraulic forcing. This scenario was applied to validate the model, (see previous chapter), and to indicate the tidal characteristics with the corresponding effect on the research area. With the construction of Delta21, the tidal propagation through the area will change significantly, both in tidal range and tidal flow conditions.

The tidal propagation for the initial bathymetry is presented by Figure 6.1, where the water level and velocity signals are given at key locations in the tidal lake and a reference location offshore, outside the tidal lake. These figures clearly indicate the phase lag per station, decrease of tidal range throughout the tidal lake and tidal asymmetry regarding ebb flow and flood flow. The tidal asymmetry indicates that the tidal lake is flood dominant (Bosboom & Stive, 2021). The remaining plots in Figure 6.1 represent 4 phases of flow patterns within the tidal cycles that contain relevant vector fields, as well as the in- and outflow by the dominant tide. Regarding the 4 phases, the tidal propagation through the tidal lake is explained below for each stage in the tidal cycle.

- *Phase 1 & 4:* Flood flow enters the tidal lake through the narrowing at the storm surge barrier, accompanied with high flow velocities up to almost 2 m/s in phase 3. The flow does not follow the channel directly, but first flows to the northern part of the tidal lake between the Delta21 dunes and the Hinderplaat. Shortly after that the tidal current flows mainly through the channel towards the Haringvliet sluices. In the northern part of the tidal lake the flow propagates around the local banks, from which it flows through the Rak van Scheelhoek, right from the Hinderplaat, to the Haringvliet sluices. Another phenomena are the deflected flow velocities at the southern side of the Hinderplaat ([59 km, 432 km]), which are mainly directed towards the channel.
- *Phase 2:* For ebb flow, the patterns of the velocities are similar but opposite to the flood flow. However, ebb flow lasts longer due to the tidal asymmetry, which can also be observed from the velocity signal at the key locations. The asymmetry results in lower but longer ebb flow velocities as for flood. In addition, the discharge flow increases the flow magnitude of the ebb flow and decreases the flood flow, especially in the channel.
- *Phase 3:* Around flow reversal, there is mainly flow in the channel, which is due to the phase lag and damping of the tidal flow. The phase lag can be seen by comparing the water level and velocity signal at key locations. Also, the damping can be observed from the decrease in water level and flow velocity, when comparing the offshore signals to the signals in the tidal lake. Similar to flood flow, quite significant velocity gradients occur at the Hinderplaat. Deflected velocity currents occur westerly of the Hinderplaat, which are perpendicular to the channel orientation. Also, at the same Hinderplaat location as phases 1 and 3, eddy velocities occur at flow reversal. Both phenomena at the Hinderplaat should be accounted for in further analysis on the channel.

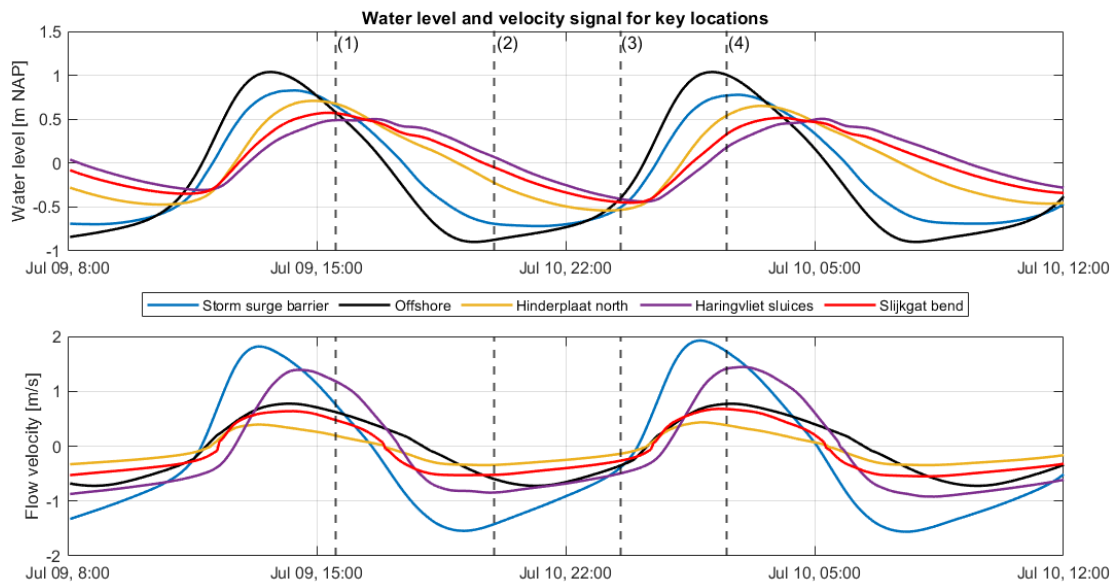
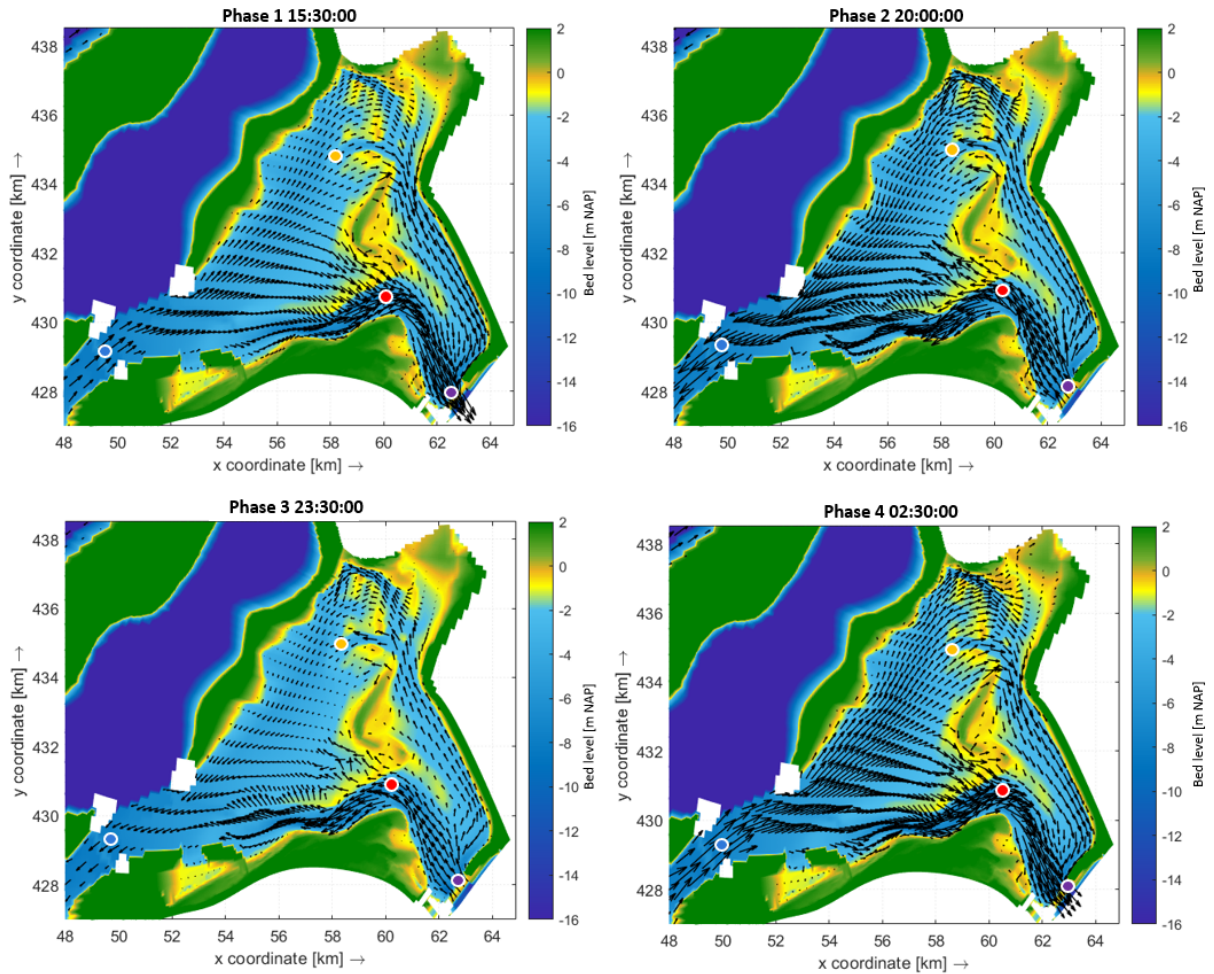

Figure 6.1: Water level and flow velocity over two tidal cycles at key locations. Added are four selected phases of the flow velocity patterns in the tidal lake. The colours of the graphs correspond with the coloured dots in the phase-figures. The water level and flow velocity magnitude at each phase, at key locations, is indicated by the dotted lines in the lower figures.

6.1.2 Tidal prism

The yearly change in tidal prism is determined for each concept. These changes after one year of modelling are listed in Table 6.1. For the initial concept, the tidal prism decreases approximately by 8% over the modelling period. This means that the discharges through the inlet decreases over time. Among other things, this results in lower flow velocities by the tidal forcing in the tidal lake. In terms of sediment transport, a decrease of tidal prism leads to a decrease of the required tidal channel volume (Bosboom & Stive, 2021). For the tidal lake it holds that the volume of the design channel is the main storage of the tidal channels. So, the design channel requires a lower storage volume and will therefore import sediment to fit the changed tidal prism. The imported sediment originates outside the tidal lake from the present ebb tidal delta and otherwise the sediment of adjacent coastlines. Considering the effect on the design channel, the decrease of tidal prism may enhance import of sediment into the channel, which may increase the sedimentation in the channel.

Considering the tidal prism change of the two channel concepts, a similar outcome is observed. Both tidal prisms at P_0 are larger than the initial bathymetry. This is due to the new concepts being dredged deeper and wider, which allows for more storage. The larger channel 2 tidal prism is due to the disappearance of the Kwade Hoek, which gives even more storage capacity in the tidal lake. The change in tidal prism also results in a decrease over time. However, the percentage for the two concepts is smaller than the initial concept. With the deepening and increase of storage in the channels, the resistance of the flow has decreased. This allows the tide to flow in and out the tidal lake with lower resistance, resulting in more water to flow in and out of the tidal lake. Therefore, the decrease in tidal prism is smaller in terms of percentage as the initial bathymetry. Additionally, the increase of in- and outflow prevents an increase of sedimentation due to the larger cross-sectional area of the channel that has been formed, which is convenient.

Table 6.1: Change in tidal prism over one year of morphological modelling for each concept. The tidal prism is computed with the flow at the new storm surge barrier. Where P_0 is the initial tidal prism and P_1 the changed.

	P_0 [Mm ³]	P_1 [Mm ³]	Δ [%]
Initial bathymetry	1.92	1.77	-7.9
Channel 1	2.16	2.12	-1.7
Channel 2	2.24	2.19	-2.2

6.1.3 Flow velocities in the channel

The flow velocity results that are discussed in this section are based on computations with the implementation of the weighted discharge year as discharge boundary condition. The results that will be discussed are:

- Flow velocity patterns in and around the channel concepts at the same moment in time. This in order to compare the flow patterns of the concepts with each other. The chosen moment is approximately after 3 months of morphological modelling, when a yearly mean discharge flows through the channel during two tidal cycles.
- The maximum occurring velocities per concept. This quantitative assessment will indicate the extreme longitudinal and cross current velocity components in order to make the comparison to the requirements on these velocity magnitudes.

The concepts are divided into four segments each, which can be seen in Figure 6.2 on the right. These segments are defined in order to support the explanations of the discussed results. Segment D is the area of the westerly end of the channel and the remaining area to the spillway and storm surge barrier. These segments will be referred to in the coming paragraphs as well as the morphological results in Section 6.2.

Flow velocity patterns

The results of the flow velocity patterns are considered for each concept. Similar to the tidal propagation figures, four moments in time are selected to discuss, which are assumed to represent the relevant velocity patterns. An elaborate listing of the findings for each channel concept can be found in Appendix E.1, with the accompanying figures presented as well. In this section the most relevant findings are listed shortly for each concept and compared to each other.

Initial bathymetry

- Within Segments A and B, the velocities are high in comparison to the surroundings. This is the case for both flood flow and ebb flow, including discharge. As mentioned in Section 6.1.1, the tide flows in and out the tidal lake in northern direction. This results in significant cross currents at channel Segment D.

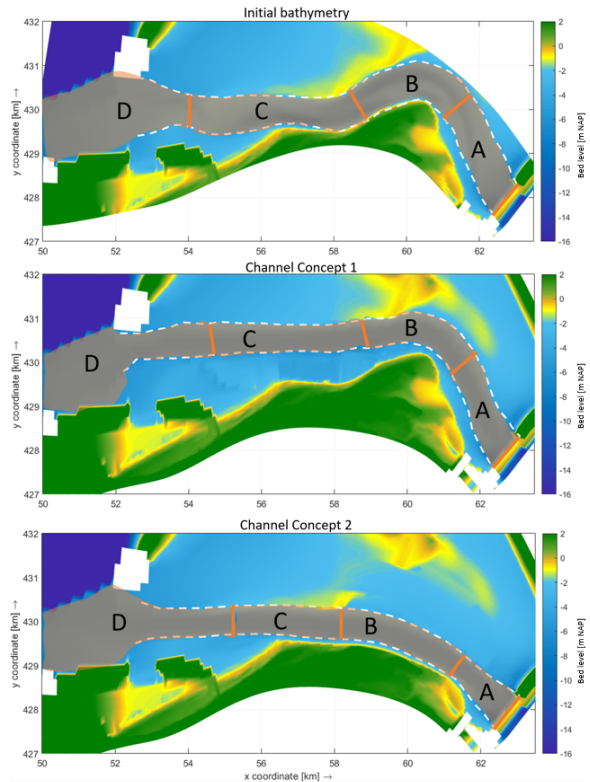

Figure 6.2: Defined channel segments per concept, including the initial bathymetry with the Slijkgat.

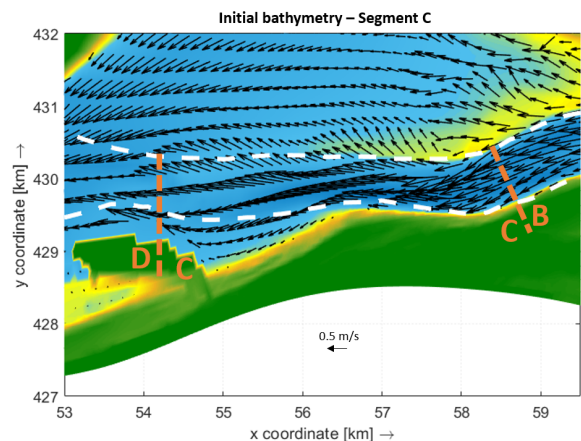

Figure 6.3: Closeup of the flow in Segment C for the initial bathymetry, including segments transition.

- In Segment C, the flow decelerates and even deflects to a cross-channel direction. This local velocity gradient is due to the locally deeper parts of the surrounding bed, which allows more storage of flow from the channel. This too leads to increase of turbulence in and around the channel. See Figure 6.3 for a detailed representation of the velocity gradients in Segment C.
- Outside of the channel at the Hinderplaat, eddy velocities at flow reversal occur and overflow with flood flow. These flows are direction to the channel and enhances transport.

Channel Concept 1

- Similar phenomena can be observed with respect to the initial bathymetry. High flow velocities flow through Segments A and B, velocity gradients occur in Segment C and in Segment D the flow accelerates and remains relatively high throughout the segment. The main difference is in Segment C, where the velocity gradients and deflections are more significant to the initial bathymetry and stretches over a longer distance. This is observed for flood flow in Figure 6.4, which also occurs in reverse at ebb flow. This is due to dredging part of the the Hinderplaat for the design, which lead to a longer stretch of deeper boundaries along the channel with respect to the current Slijkgat.

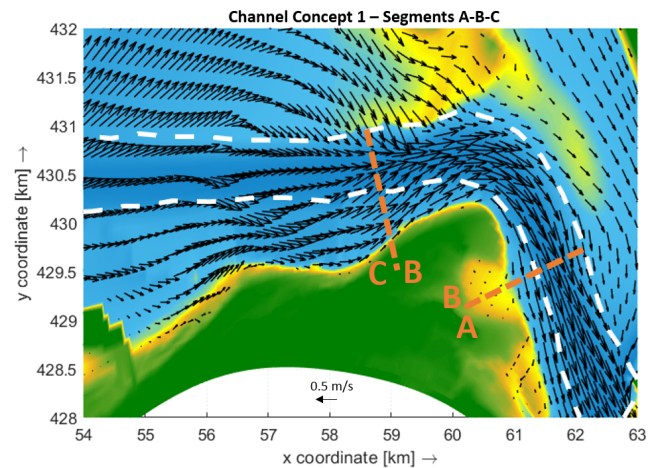

Figure 6.4: Closeup of flow patterns in transition of Segments B to C for Channel Concept 1, including segments transition.

Channel Concept 2

- The mitigation of the curvature of the bend in the design results in the flow being less exposed to curved and helical flow within the channel. This still results in high velocities over a long stretch of the channel, but less in velocity gradients outside of the bend. This is also observed from the results, where less gradients and deflections occur at the transition of Segment B and C (see Figure 6.5). Instead the gradients occur at the transition of C and D, where locally the surrounding area is deeper. Still, the gradients are less significant with respect to the other concepts.

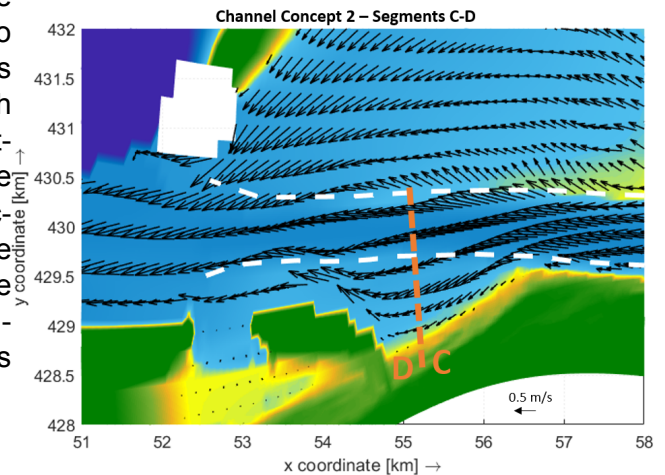

Figure 6.5: Closeup of flow patterns in transition of Segments C to D for Channel Concept 2, including segments transition.

Longitudinal and cross current velocities

The quantitative analysis of the velocity components is carried out by the described method in Chapter 5. Figure 6.6 represents the analysis results of the two components along the channel, halfway the tidal cycle, which is a representative chosen time during ebb flow. The outer boundaries on the y-axis represent the (absolute) design velocities, which is 1.5 m/s for longitudinal currents and 0.75 m/s for cross currents. The lower boundary of the longitudinal current is extended and the design boundary is indicated by a dashed line. Notice that for this hour, the boundary condition is exceeded on a

few points along the channels and the cross currents do not exceed the boundary. The latter holds for all hours and the longitudinal velocities exceed for a few other hours as well. For the remaining results see Appendix E.2. The exceedence of the longitudinal velocity is not a direct threat for the corresponding requirement, rather the repetition of which it occurs. If the threshold velocity is exceeded too often at many locations, it threatens the safety that is required of the channel. Therefore, an exceedence probability is chosen to indicate the navigable safety during extreme daily conditions.

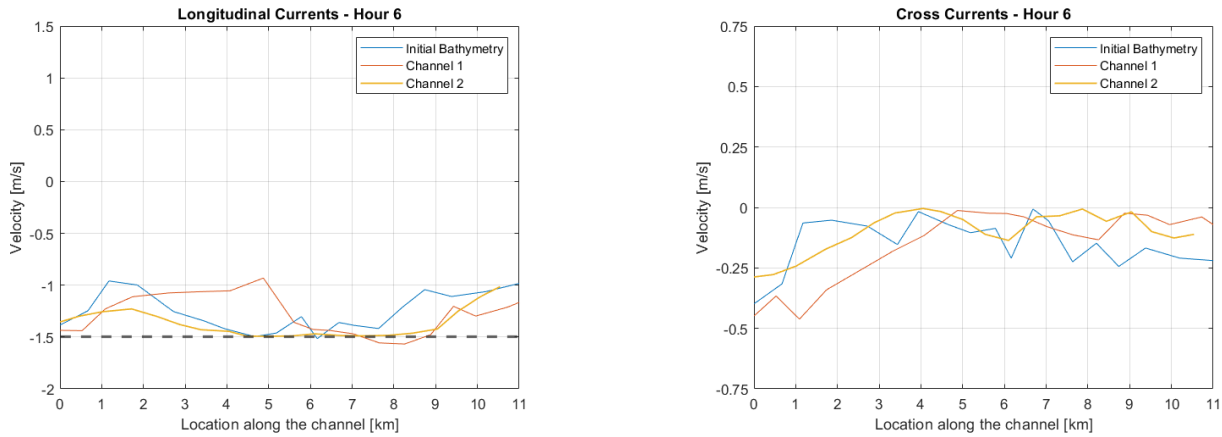

Figure 6.6: Longitudinal and cross current velocities halfway the selected tidal cycle for each concept. The maximum design velocities are indicated by the figure boundaries or a dashed line.

The velocity gradient per component is computed between the points along the channel. The results can be found in Appendix E.2 and the gradients halfway the tidal cycle are given in Figure 6.7. These gradients are chosen halfway the tidal cycle as well as the velocity components, because this moment gives the most relevant representation of the gradients.

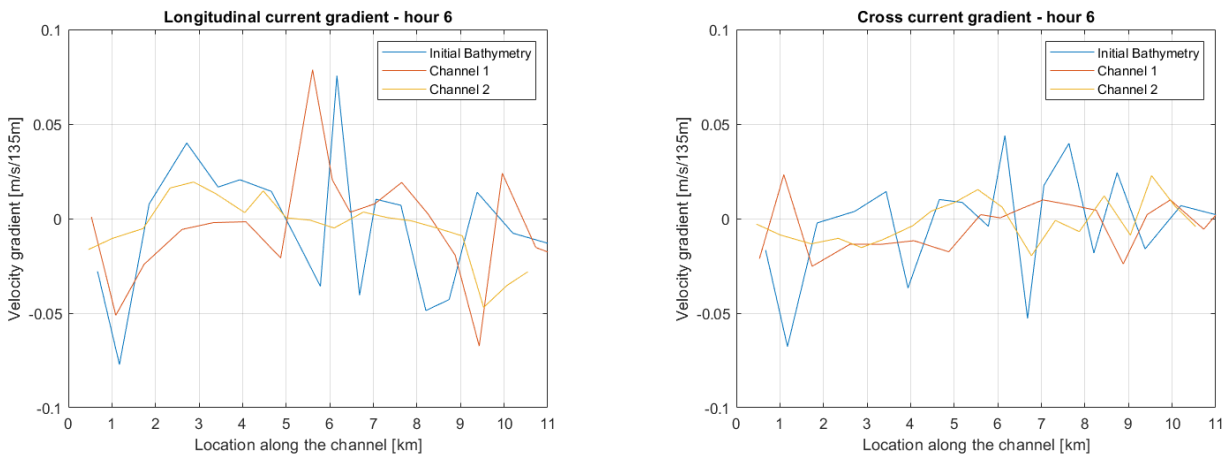

Figure 6.7: Longitudinal and cross current velocity gradient [m/s/135m] halfway the selected tidal cycle for each concept.

Both components show a respectively large deviation in velocity gradients. Mainly the initial bathymetry and Channel Concept 1 show large volatility along the channel. So, gradients over different directions. The gradients are defined over the ship length of 135 m. The y-axis boundaries are thus set (absolute) at 0.1 m/s/135 m. These results are not significant, but still may result in manoeuvring difficulties. Channel Concept 2 on the other hand shows little gradient deviations and magnitudes with respect to the other concepts.

Extreme conditions flow patterns

The extreme conditions are considered without the tide and a discharge ranging from 7,500 m³/s to 10,000 m³/s. Velocities of this scenario are thus directed from the Haringvliet sluices to the spillway only, with low velocity gradients. The flow velocity results are assumed straightforward with respect to the normal conditions. Therefore, only the patterns of the velocities and the corresponding magnitudes are considered for the extreme conditions. Figures 6.8 and 6.9 show the flow patterns and velocity magnitudes during maximum discharge through the channel and tidal lake. Maximum occurring flow velocities are up to 1.5 m/s. This velocity is significant but similar to the tidal velocities, which happens every day. Channel Concept 1 is shown as an example, because similar patterns and magnitudes occur for the other concepts.

The extreme flow velocities of the extreme conditions are similar to those under daily conditions. The velocities, forced by the tide, are even slightly larger than those caused by a discharge of 10,000 m³/s. Also net sediment transport as a consequence will be larger for normal conditions. The flow under normal conditions is therefore considered normative with respect to the extreme conditions.

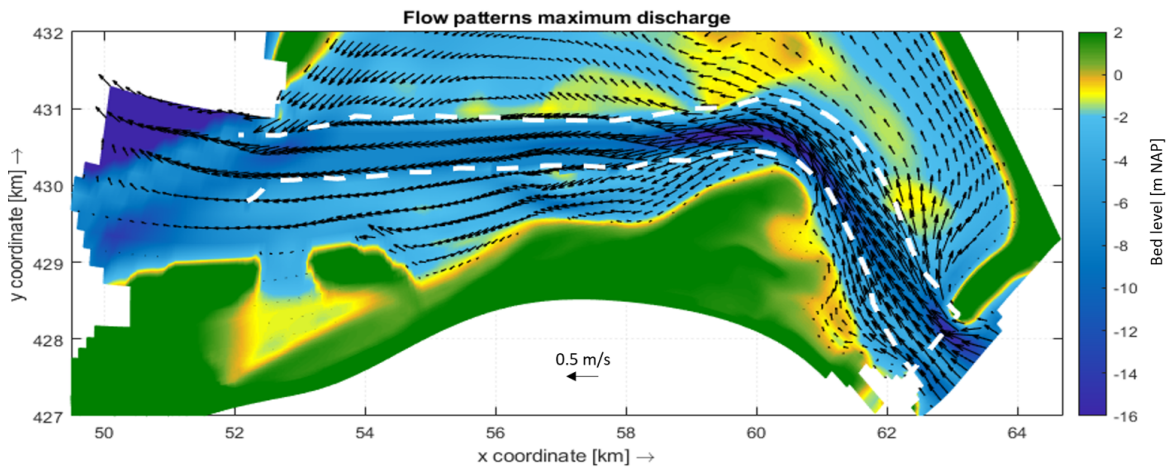

Figure 6.8: Flow patterns through Channel Concept 1 at maximum discharge, assuming extreme conditions.

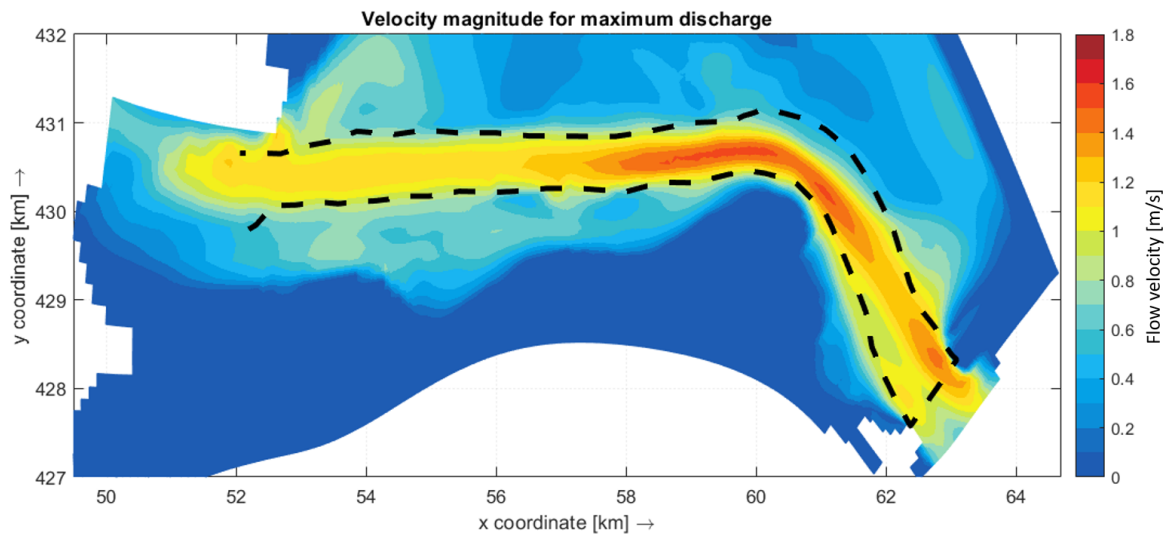

Figure 6.9: Flow velocity through Channel Concept 1 at maximum discharge, assuming extreme conditions.

6.2 Morphological results

6.2.1 Bed level changes

The morphological response after one year of modelling has resulted in major bed level changes in each of the channel concepts. The patterns and rates of erosion and sedimentation are discussed in the next paragraph. The bed after one year is presented in this section, see Figure 6.10. A threshold level slightly above the navigable depth at NAP - 7 m is indicated by the colour yellow. Shallower depths are indicated by yellow to red. Equal and deeper parts as the required depth are presented by blue. First observations for each concepts are listed below:

- The initial bathymetry shows very little navigable parts after one year. The parts that are navigable are narrow and are adjacent to sedimented parts. The part between the Haringvliet sluices and the bend shows a light yellow colour, which nearly fits the required depth and thus requires little maintenance. Other sedimentated parts in the channel show a more orange colour. This implies several meters of sedimentations, which requires extensive dredging maintenance.

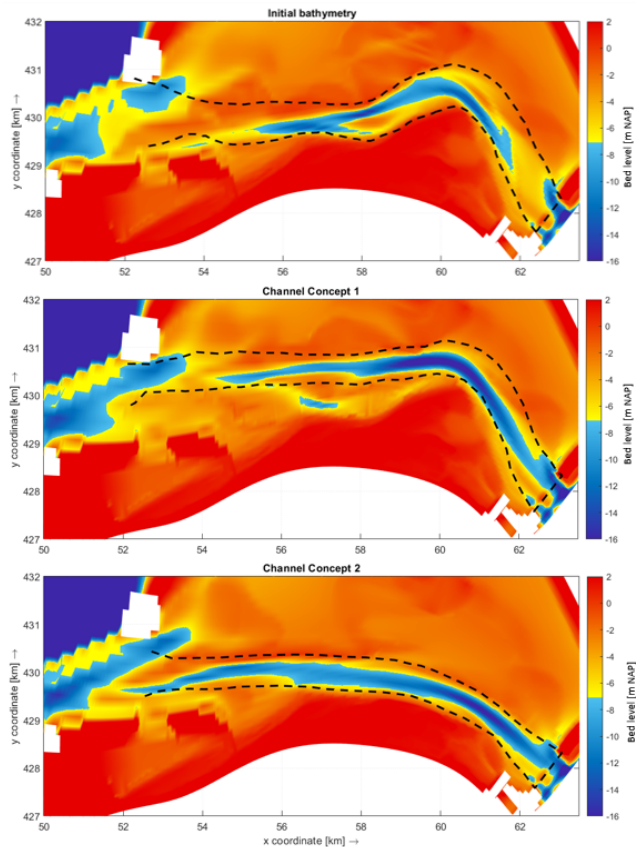

Figure 6.10: Bed level after one year of modelling for each channel concept. A rough transition is implemented at NAP -7 m to indicate the parts that do meet the required navigable depth and parts that do not.

- Channel Concept 1 shows a long stretch of navigable length along the channel, but with a narrow width. At the western end, sedimentation has led to an unnavigable part in the channel. Also, along the boundaries of the channel, sedimentation has increased the depth and migrate to the centre of the channel. These sedimentations may lead to large maintenance dredging as well.
- Channel Concept 2 shows a somewhat better navigability throughout the channel. The stretch of navigable depth is almost fully remained. The navigable width has narrowed on a few locations along the channel. The main sedimentation is the large and orange bank that has formed at the western end of the channel. This phenomena has been noticed for all concepts and corresponds to the flow patterns and velocity magnitudes, mentioned in the previous section and should be emphasised in the next sections. Nonetheless, the bed level change of this channel concept is clearly most suitable with respect to the other concepts in maintaining navigability.

6.2.2 Erosion and sedimentation patterns

The listing is applied the same as for the flow velocity patterns, where for each concept the relevant findings are discussed. The elaborate findings and accompanying figures are reported in Appendix E.3.

Initial bathymetry

- There are two bends in Segment B and the transition with C, where in the inner bends erosion occurs and sedimentation in the outer bends. This narrows the navigable width. The outer bend accretes with sediment due to deceleration over the bend and inflow of sediment from the Hinderplaat. At the transition of Segments B and C, the local velocity gradients are probably the source of the more significant and developing sedimentation, associated with the erosion. Additionally, the inflow and outflow of the tide may enhance new flood and ebb channels, which phenomena occurs for this channel as well.
- Increasing sedimentation over time occurs at the transition of Segments C and D. This is due to the locally deceleration of the flows from both directions of the channel, so the upstream outflow and the inflow at the inlet. This stretch of sedimentation is spread over a significant area in the channel, which does not fit the navigable requirements and requires maintenance.
- In terms of erosion, in Segment C there are high velocities that result in migrating erosion in westerly direction. This is associated with sediment deposition at the channel boundaries and the already mentioned sedimentation at the transition of Segments C and D.
- The tidal inflow and outflow around the inlet does result in formation of erosion in Segment D and in northern direction. This flow direction is in line with the in- and outflow at the inlet. This too contributes to the sedimentation at the decelerated area between Segments C and D.

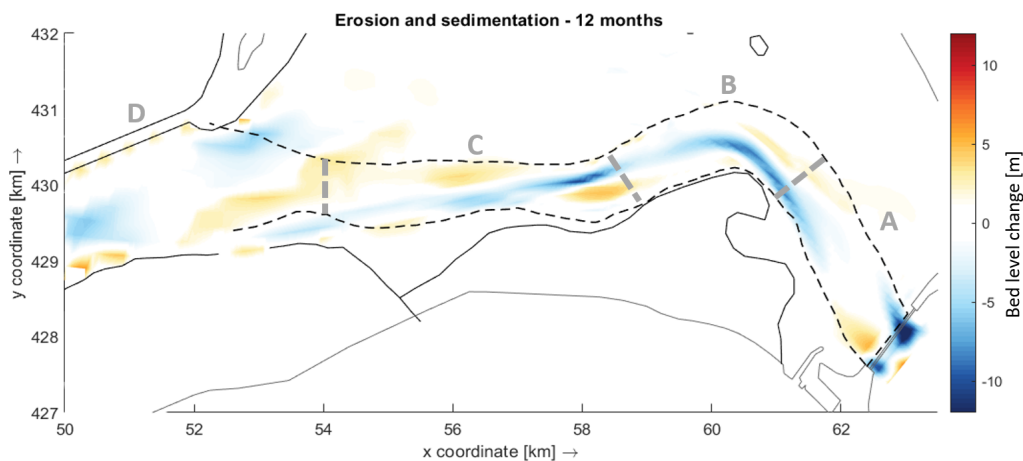

Figure 6.11: Erosion and sedimentation after one year of morphological modelling of the initial bathymetry concept, including the indicated segments.

Channel Concept 1

- The erosion in the bend is more significant with respect the initial bathymetry. The flow experiences less curvature of the flow, which enhances acceleration in both flow directions and thus more significant erosion. The eroded material is transported to adjacent areas, where it is deposited at locations with decelerated flow.
- The accelerating flow in the bend results in a relatively large deceleration in Segment C. Together with the higher velocities in the adjacent segments, results in the extensive sedimentation in Segment C. Mainly this area is a bottleneck to maintain navigability. It is a relatively large stretch in the newly designed straight channel segment, which thus almost entirely should be maintained by dredging.
- When considering the sedimentation and erosion after one year, the geometry of this concept is changed significantly in Segment C and also outside the channel. Due to the tidal flow and deeper adjacent parts for storage, certain tidal channels develop with adjacent sedimented areas.

- The amounts and locations of sedimentation results initially to blockage of the navigability in Segment C. Over the entire cross-section the required depth is not fulfilled. Over time a narrow (new) channel forms south of Segment C, which is due to the flood flow and deflected flow out of the upstream bend. In between the channels, sedimentation is enhanced and narrows the main channel. This channel concept thus requires extensive dredging.

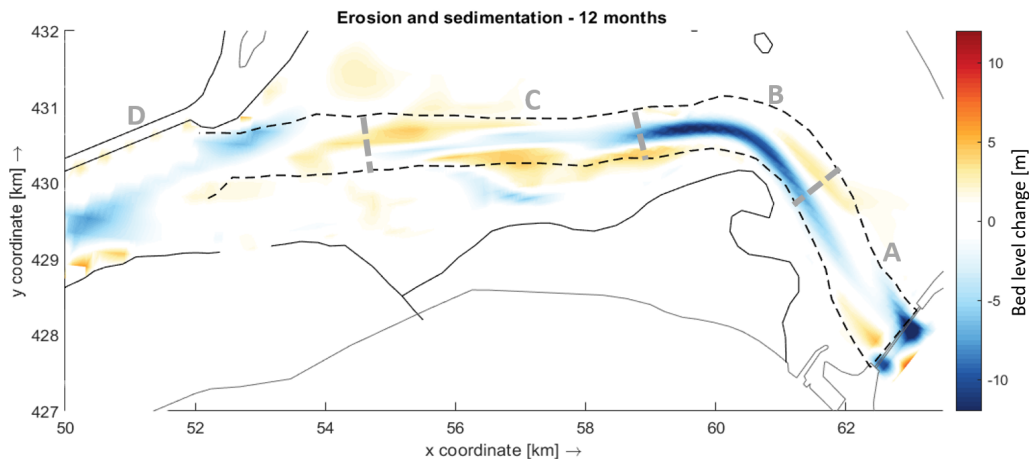

Figure 6.12: Erosion and sedimentation after one year of morphological modelling of Channel Concept 1, including the indicated segments.

Channel Concept 2

- This concept is less influenced by curvature of flow due to the absence of the bend. This results in less deflection of the flow and velocity gradients in Segments A to C. It does result in erosion by high velocities along this stretch, which develops by accompanying increasing velocities.
- Downstream at the transition of Segments C and D, sedimentation occurs. This is due to local deceleration of the flow and deposition of the transported sediment. The transported sediment originates from the seaside of the tidal lake by flood flow. For ebb it comes from the erosion in the channel and the inflow of sediment from the Hinderplaat and other areas of the tidal lake. The sedimentation is quite concentrated at the location, which is convenient for maintenance and for any mitigation of the sedimentation.
- Dredging measures should be considered for this amount of sedimentation to fulfil the requirements. However, due to the concentrated location of sediment and the well contained orientation of the channel, the dredging should be managed better than the other concepts (see Figure 6.13). Also, the concentrated sedimentation is convenient to tackle, regarding certain mitigation measures.

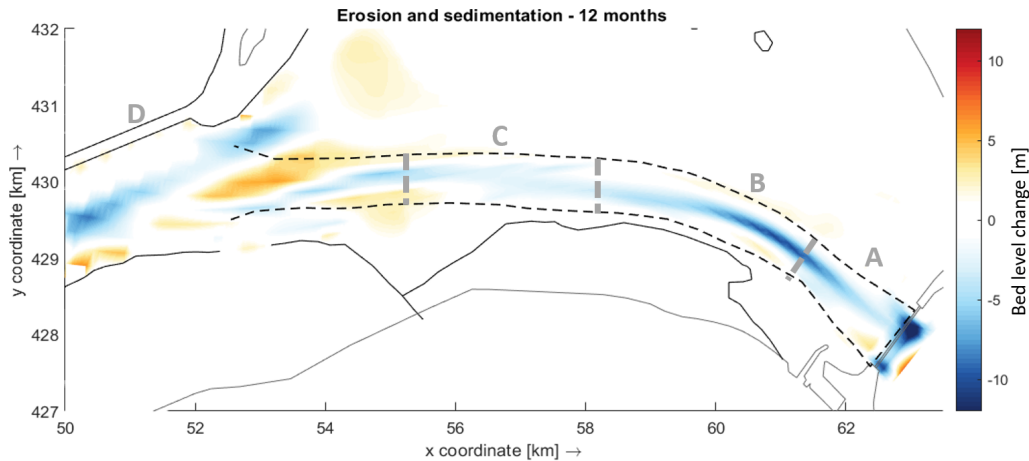

Figure 6.13: Erosion and sedimentation after one year of morphological modelling of Channel Concept 2, including the indicated segments.

Second year results

The second year modelling is performed with the same input as the first year, except for the bathymetry. The applied bathymetry for each concept is the bathymetry after one year of modelling and which is dredged to the required design depth. The results are discussed in a less detailed matter and are mainly as a comparison to the results after one year of modelling. The differences with respect to the year before are mentioned for each concept and relate to the presented results in Figure 6.14.

- The bed level of the initial bathymetry concept has changed in the second year. The erosion has proceeded throughout the channel and in the western part it is guided south due to the large sedimentation at the western end of the channel. The sedimentation throughout the channel has decreased, but is concentrated more on the western end of the channel. This morphological development is similar and with the same cause as Channel Concept 2 after one year. The total sedimentation in the channel has decreased to a similar amount as Channel Concept 2 after one year. The navigable channel has shifted to the south, which is an extension of the first year phenomena. In the eastern part of the channel, the sedimentation patterns are decreased clearly. Apparently, the flow is more stable and results in less cross-sectional sediment transport and deposition. In terms of sedimentation, the second year results for the initial bathymetry is considered an improvement with respect to the first year and requires less maintenance.

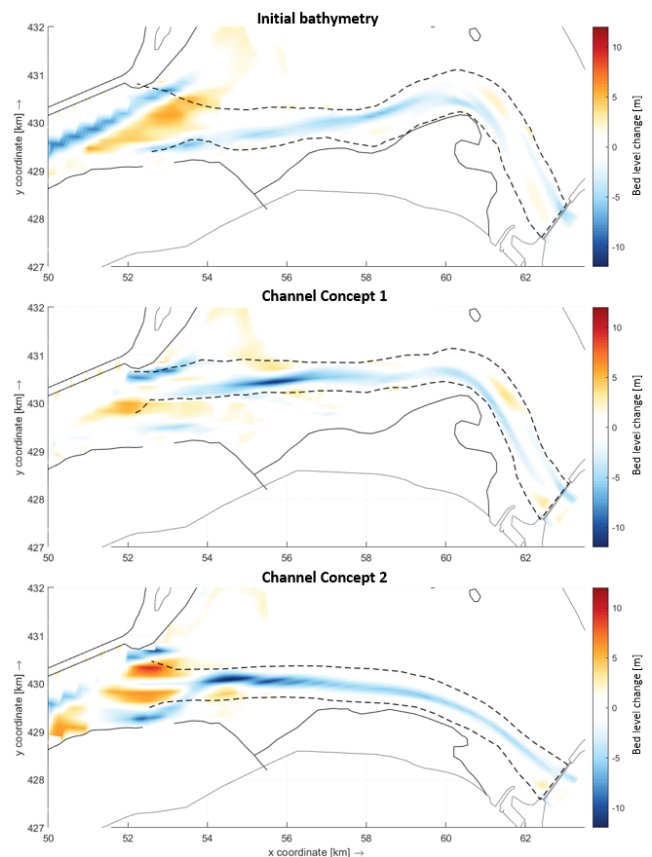

Figure 6.14: Erosion and sedimentation patterns after two years of modelling for the three concepts.

- A similar development is observed for Channel Concept 1 as the initial bathymetry. The erosion has proceeded through the channel, which has led to decrease of sedimentation at many locations. The most sedimentation has relocated to the western end of the channel, but is of a much smaller size and amount as before. Also for Channel Concept 1, the second year results are considered an improvement with respect to the first year. Large sedimented areas have decreased and the orientation of the channel is well observed by the erosion patterns and thus contributes to the navigability.
- The second year erosion and sedimentation patterns of Channel Concept 2 show similar results as the previous year. The sedimentation is still concentrated at the same location, but has not decreased as was observed for the other concepts. The northern directed erosion stretch has decreased and is blocked by the sedimentation. This is not necessarily assumed an improvement. Certain erosion stretches are formed through and around the sedimented bank. This is not beneficial for the flow, which in this case is deflected in bifurcating channel and results in velocity gradient. For Channel Concept 2, the second year results are not considered an improvement with respect to the first year patterns. The sedimentation has not clearly decreased and the bottlenecks are unchanged and somewhat worsened as well.

Extreme conditions

The extreme conditions results of the sedimentation and erosion are discussed shortly in this paragraph. The flow patterns, observed in the hydrodynamics results, do not result in significant flow velocities with respect to the normal conditions. Therefore, also the morphological results are less significant, considering the design discharge. The results are given in Figure 6.15 and are discussed for each concept.

- The main erosion and sedimentation occurs at the Haringvliet sluices, where the design discharge enters the tidal lake. This is the narrowest passage of the discharge, which thus results in maximum velocities. This is accompanied by the largest erosion in the channel. Furthermore, a few small sedimented spots are observed. Due to the almost constant flow through the tidal lake, it is assumed that certain transitions of grid cells result in irregularities in computations. Besides these spots, very little sedimentation is observed for extreme conditions. The most significant areas result in a bed level change of 20 to 30 cm. This may cause little disturbance for navigability, but not compared to the normal conditions results.

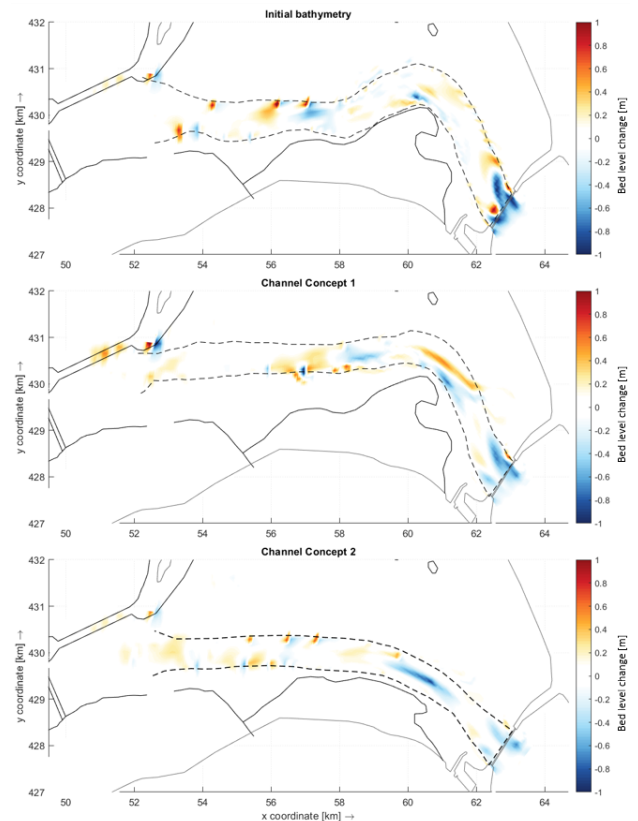

Figure 6.15: Erosion and sedimentation patterns ([m]) for the three concepts after one week of a closed storm surge barrier with extreme discharge.

- The sedimentation in Channel Concept 1 occurs at similar locations as for the normal conditions, in the straight segment of the channel and in the bend. The amount of sedimentation is somewhat larger as the initial bathymetry and reach a maximum bed level change around 50 to 60 cm. Still, the morphological response of the extreme conditions is not considered major in terms of threat to navigability. Maintenance could be considered on shorter notice, but mainly due to the adjacent effect by the normal conditions.
- The sedimentation in the channel of Channel Concept 2 is the least, compared to the other concepts. The sedimentation occurs at a few small locations and the magnitudes are little. The maximum bed level increase is around 20 cm, but does not pose a threat for navigability.

The morphological results of the extreme conditions are not considered normative with respect to those of the normal conditions. This is confirmed by the explanations for each concept. Therefore, these results are not discussed further in next sections of this chapter

6.2.3 Sediment volume changes

One year modelling results

For this analysis, again the results, assuming the weighted discharge year are considered. The development of the sedimentation and erosion during one year is given in Figure 6.16. This development is similar for all the concepts and shows the significant volume change in the first month, from which it increases more gradually. This sudden increase in the first month is mainly due to the large discharges, which occur in the storm season. Nonetheless, the increase is still significant.

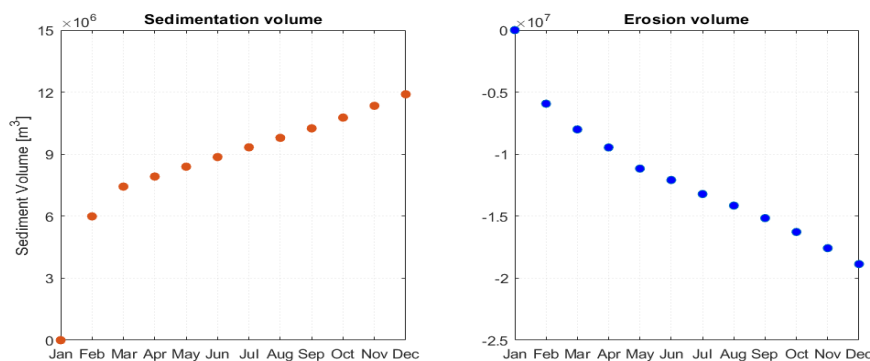

Figure 6.16: Cumulative erosion and sedimentation development over one year of Channel Concept 1.

The total volume changes after one year have been computed for each concept. These total volumes are listed in Table 6.2. For the erosion and sedimentation volumes holds:

- The erosion for each channel concept shows little deviation when comparing and are all significant in magnitude compared to the sedimentation. Much of the sediment is thus transported outside of the tidal lake, since the sediment transport outside of the channel, in the tidal lake, is not of the order of magnitude ($\approx 0.5 \text{ Mm}^3$) of the channel.
- The sedimentation volumes differ more, when comparing the concepts with each other. The initial bathymetry and Channel Concept 1 are almost similar in magnitude. Although the computed area of the initial concept is larger and thus may result in a slight exaggeration. Nonetheless, the sedimentation of Channel Concept 2 is approximately 20% smaller compared to the others. This was already expected by the results of Section 6.2.2, where a more concentrated sedimentation area was observed with respect to the other two. This significantly lower amount of sedimentation will result in less required maintenance as well.

Table 6.2: Erosion and sedimentation volumes in the channel after one year of morphological modelling, assuming the weighted discharge year.

	Sedimentation [Mm³]	Erosion [Mm³]
Initial bathymetry	12.6	18.4
Channel 1	11.9	18.9
Channel 2	9.5	18.6

Second-year volumes

The erosion and sedimentation volumes of the second year of modelling are determined as well, to have a quantitative comparison with the volume results of the first year. The computed volumes are listed in Table 6.3

- The erosion volumes are less similar with respect to the first year results. For the initial bathymetry the erosion has increased. This was already observed in the erosion patterns that proceeded through the channel and which is due to the increase of flow velocity. The latter is due to the dredging to the required depth, which is implemented as input for the second year model run. Erosion of the new channel concepts have decreased. Channel Concept 1 showed less sedimentation and erosion, which coincide with one another. For Channel Concept 2, the decrease in erosion is probably due to the proceeded blockage of the tidal flow in northern direction.
- The sedimentation results show an overall improvement of the required dredging. The volumes are computed with respect to the required navigable depth. So, the sedimentation that results in a depth above NAP -7 m is included. The initial bathymetry and Channel Concept 1 show a decrease in sedimented volume of respectively 26% and 34%. These are significant decreases in sedimentation and give a promising representation of the long-term sedimentation. Channel Concept 2 has decreased 3% in sedimented volume. This is a less significant decrease and is not considered significant and an improvement. The discussed sedimentation patterns did not show a clear decrease too, rather an enhancement of a sand bank westerly of the channel. Therefore, for Channel Concept 2, a long-term sedimentation development is less predictable, mainly due to the small difference in volume change.

Table 6.3: Erosion and sedimentation volumes in the channel after second year of morphological modelling, assuming a mean discharge year.

	Sedimentation [Mm³]	Erosion [Mm³]
Initial bathymetry	9.3	20.8
Channel 1	7.8	16.8
Channel 2	9.2	16.8

6.3 Concluding remarks

The concluding remarks for this chapter are given in the answers to the third research sub-question. The question is formulated first and followed by the answer.

How will the morphological response influence the navigability, discharge capacity and maintainability of the channel concepts?

The morphological response of the three considered channel concepts are assessed in a qualitative and quantitative matter. This response is the result of the flow in and around the channel, which are mainly influenced by changes in magnitude, direction and gradients of the flow.

The navigability is influenced greatly by the morphological response after one year of modelling under normal conditions. The tidal flow, together with river discharge, result in significant sediment transport in the channels. Besides the erosion, sedimentation occurs throughout the channels, mainly at locations with decelerating flow or deflection of the flow. It depends on the channel configuration, which locations are subjected to sedimentation. Nonetheless, long stretches and cross-sections are sedimented throughout the channels. This results in many locations not meeting the required depth or width. The latter occurs occasionally. Channel Concept 2 has the least locations of not meeting the required depth, due to a concentrated sedimentation only. This concept also has the least sedimentation volume, approximately 20% less, compared to the other concepts. This lower volume, together with the concentrated location of the sedimentation allows for a better maintainability operation with respect to the other concepts. However, a second year modelling has resulted in a significant improvement for the initial bathymetry and Channel Concept 1, both in sedimentation patterns and volume. The long-term development for these two concepts shows a decrease in sedimentation and consequently an improvement for maintainability. Channel Concept 2 does not show a clear difference in the second year and can not be considered to either improve or worsen over time in terms of maintainability.

Influence of the discharge capacity is based on the morphological response of the extreme conditions. The flow velocities that result from the design discharge are not considered significant, comparing to normal conditions velocities. The morphological response under extreme conditions shows, for all concepts, a maximum bed level change of approximately 50 cm. This is a large amount within a week of modelling, but is in this case not considered significant, since this bed level change occurs under normal conditions as well over larger areas. Therefore, the design discharge does not influence the discharge capacity significantly. The morphological response under normal conditions does influence the discharge capacity, but not under the conditions that are at hand when the design discharge flows through the channel.

7 Evaluation and design selection

This chapter contains the evaluation of the channel concepts, which is performed by a multi criteria analysis in Section 7.1. The evaluation results in the selection of one of the designs, which is reported in Section 7.2. Finally, concluding remarks are made in Section 7.3 where the answer on the fourth research sub-question is given.

7.1 Evaluation

7.1.1 Criteria

The evaluation of the channel concepts is executed by the criteria, formulated and explained in Section 2.4. The criteria are displayed again below and the enumeration of the criteria is used in further steps of the criteria analysis.

1. Navigability

- 1.1 Navigability after extreme event with open spillway and closed storm surge barrier.
- 1.2 Undesired location and orientation change of the channel over time.
- 1.3 Navigability hindrance by flow under normal conditions.

2. Maintainability

- 2.1 Required sedimentation volume to be dredged per year (Mm^3), considering normal conditions.
- 2.2 Maintenance dredging repetition, which requires (additional) operational costs and availability of the hopper.
- 2.3 Required maintenance dredging volumes in the second year, with respect to the dredging volumes of the first year.

3. Nature preservation

- 3.1 Preservation of current sand banks and intertidal areas.

7.1.2 Multi criteria analysis

A multi criteria analysis is performed for the evaluation, which entails a scoring mechanism for each criterion per channel concept. For this analysis, the procedure described by Molenaar & Voorendt (2020) was applied. First, the weighting factors are determined per criteria with respect to each other. This allows to make a distinction between criteria that are considered relatively more important than another. Determining the mutual importance is done by comparing the criteria in a matrix (see Table 7.1). For each cell, a '1' is inserted when the criterion at the vertical axis is considered more important than the criterion at the horizontal axis. A '0' indicates that the criterion at the vertical axis is considered less important. The relative weights for each criteria is then determined by the sum of the values in a row (second last column). It turns out that Criterion 1.2 is not considered more important than any other criterion. Still, it has been assumed an important criterion to consider. Therefore, a score of 0.5 is assigned to this criterion. To prevent computations with decimals, the subtotals have been multiplied by a factor 2 to obtain the total relative weights (see second to last column). Next, the weighting factors for the criteria are determined by dividing the relative weights by the total of the relative weights. The sum of these fractions add up to 1.

Table 7.1: Relative weights determination for each criterion. The criterion numbers corresponding to the enumeration of the listed criteria. The weighting factors are given in the right column. These are calculated by: $WF_i = \frac{x_i}{\sum x_i}$, with i the criterion and x_i the relative weight of the criterion from the Total column.

	1.1	1.2	1.3	2.1	2.2	2.3	3.1	Subtotal	Total	Weighting Factor (WF)
1.1	1	0	0	0	0	0	0	2	4	0.09
1.2	0	1	0	0	0	0	0	0.5	1	0.02
1.3	1	1	1	0	1	0	1	4	8	0.19
2.1	1	1	1	1	1	1	1	6	12	0.28
2.2	0	1	0	0	1	0	0	1	2	0.05
2.3	1	1	1	0	1	1	1	5	10	0.23
3.1	1	1	0	0	1	0	1	3	6	0.14

The scoring of each criterion, per concept, leads to a final score on which the selection of the most suitable design is based. The scoring is based on a range of 1 to 5, with high scores being beneficial. Each score is based on a characteristic or range that is formulated to get to that specific score. These are set up in order to prevent arbitrary and subjective scoring in the evaluation and allow as a guidance and reasoning. The characteristics per score and per criteria are listed in Appendix F.1 and are applied for the scoring. The right characteristic is chosen per criteria and concept, regarding the results of the previous chapter.

The scoring of the multi criteria analysis has led to the results listed in Table 7.2. The argumentation for the given scores is reported in Appendix F.2 and is considering the results of the previous chapter. It turns out that there is not a large difference in the total scores of the concepts with respect to one another. Still, Channel Concept 2 is around 10% higher than the other concepts. When considering the given scores of Channel Concept 2 with respect to the other concepts, it can be seen that this concept scores higher on the navigability criteria and the short-term maintainability criteria. The scores of the long-term required maintenance and the nature preservation are worse with respect to the other concepts. The low nature preservation score has to do with the almost entirely disappearance of the Kwade Hoek. Overall, on a qualitative matter, Channel Concept 2 scores best on most of the criteria.

Table 7.2: Scoring of the criteria per concept. The total score is the sum of all the scores times the weighting factors. A shortened description of the criteria is given in the left column.

	WF	Initial bathymetry		Channel Concept 1		Channel Concept 2	
		Score	Score x WF	Score	Score x WF	Score	Score x WF
1.1. Navigability after extreme event	0.09	3	0.27	3	0.27	4	0.36
1.2. Undesired location and orientation	0.02	2	0.04	4	0.08	4	0.08
1.3. Hindrance by flow	0.19	3	0.57	3,5	0.67	4,5	0.86
2.1. Required dredging, first year	0.28	2	0.56	2	0.56	3	0.84
2.2. Maintenance repetition	0.05	2	0.10	1	0.05	3	0.15
2.3. Required dredging, second year	0.23	4	0.92	4	0.92	3	0.69
3.1. Nature preservation	0.14	4	0.56	3	0.42	2	0.28
			3.02		2.97		3.26

7.2 Design selection

Based on the multi criteria analysis in the previous section, Channel Concept 2 is selected as the most suitable option (see Figure 7.1). Besides having the highest score, it scores higher than the other concepts for most of the criteria and the weighting of the criteria. The important considerations of the scoring and the comparison to the other concepts are listed below to summarise for each criteria interest. These are respectively navigability, maintainability and nature preservation.

- Considering the results after one year, the navigability remains possible, also after an extreme event. Flow velocities are quite high, but velocities are gradually distributed flow along the channel, accompanied by low gradients. The gradual flow is supported by the absence of the bend, which is advantageous compared to the other concepts.
- In terms of maintenance, the concept scores average on all criteria. The amount of dredged material is high, but around 20% lower as the other concepts. Also, the sedimentation is concentrated in one section of the channel, instead of throughout the channel. This allows for targeted dredging operations and, as it turns out, on lower repetition. The required dredging in the second year is less favourable than other concepts. The dredging volume is however decreasing in comparison to the first year.
- Channel Concept 2 scored low on the nature preservation, which has resulted in a lower difference in total score compared to the other concepts. The disappearance of a large part of the Kwade Hoek was necessary for the bend to become more straight, which has been beneficial for navigability. Besides the construction, there is hardly any further erosion of protected sand banks. Restoring the nature areas elsewhere could be taken into account as well when considering optimisation.

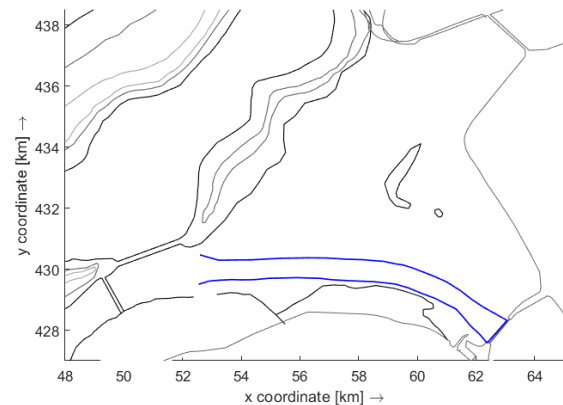

Figure 7.1: Contour of Channel Concept 2, where the orientation and location in the tidal lake is indicated.

7.3 Concluding remarks

The performed evaluation together with the results that it is based on, allows for answering the fourth research sub-question, which is formulated as:

What is the most suitable channel concept, that fits the design requirements?

The evaluation is performed in order to select the most suitable channel concept. The channel concepts do fit the requirements in essence, given maintainability operations. Criteria based on navigability, maintenance and nature preservation are considered and assessed to obtain the most suitable concept. The evaluation has led to the selection to implement Channel Concept 2 as most suitable channel in the tidal lake. This concept is characterised by the straight and short orientation. Channel Concept 2 allows for navigation most of the time, compared to the other concepts. The concept has a discharge capacity that prevents large flow velocities and accompanying gradients along the channel to occur. In terms of maintainability, it scores average in amount of dredged volume. However, the volume is concentrated at a specific location, which is considered beneficial for maintenance operations and to pose targeted mitigation measures for sedimentation formation.

8 Optimisation of channel design

The evaluation has resulted in the selection of Channel Concept 2. However, certain criteria did not score well in the evaluation and require improvements for a better application. This chapter proposes an optimisation for Channel Concept 2. The first section introduces the intervention and discusses the supposed improvement. Section 8.2 explains the results of numerical modelling results for the improved layout. Finally, some concluding remarks are given from the chapter as well as the answer to the sixth research sub-question.

8.1 Intervention

The main disadvantages of Channel Concept 2 were:

- The long-term sedimentation in the channel, which hardly decreased.
- The disappearance of the Kwade hoek for construction of the channel.

The latter disadvantage is difficult to mitigate, since the orientation and construction will not change by an intervention. It could enhance development of tidal nature elsewhere, but that is not assumed a significant improvement on the concept. Therefore, for the intervention the objective is to improve the rate of sedimentation in the channel and prevent to have a negative effect on other good scoring criteria, such as hindrance by flow.

The intervention should improve the sedimentation in the channel, by decreasing it. The sedimentation patterns after one year of morphological modelling were concentrated in the western part of Channel Concept 2 (see Figure 8.1). A similar development was observed after 2 years. The sedimentation occurs at this location, because of a decrease of flow velocity with respect to the surrounding areas where erosion occurs, north and south of the sedimentation. Solutions by an intervention that changes the dynamics that result in these patterns is twofold:

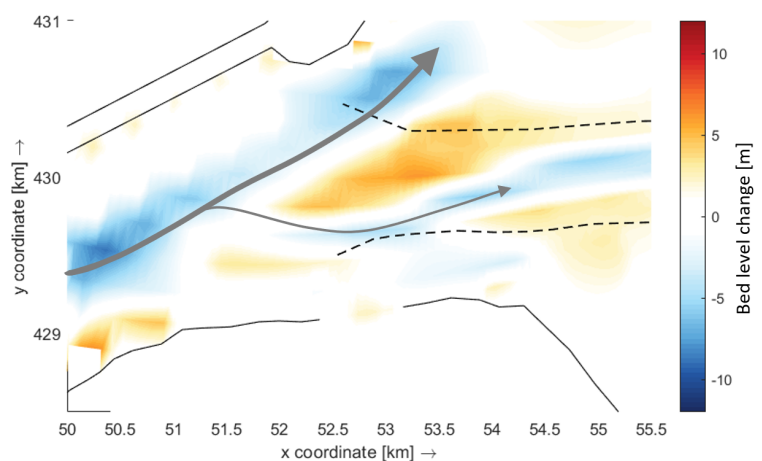

Figure 8.1: Closeup of erosion and sedimentation after 1 year of at the western part of the channel.

- The flood flow is in line with the inlet and flows mainly in northern direction, instead of through the channel. This is observed in Figure 8.1 by the grey arrow along the eroded parts. By closing off the flow in northern direction, the flow is forced to follow the path of the channel. This prevents flowing in northern direction from the inlet and allows for higher flow velocities at the sedimented part of the channel. Also, less deflection of flow is stimulated and is guided gradually through the channel.
- Increasing the flow velocity locally, could be done by narrowing the passage of the flow. The sedimentation location is surrounded by less shallow parts, which allows for more storage and decrease in flow velocity. A local narrowing or decrease in storage could enhance higher flow velocities at this specific location and prevent extensive sedimentation. An outcome to take under consideration would be that the local flow velocities could increase to significant magnitudes, which results in dangerous situations. Also, the sedimentation may decrease at the discussed location, but deposit elsewhere in the channel.

The posed solutions could be realised by implementing a retaining structure that blocks the northern directed flow and that narrows the channel locally. This can be realised by implementing a hard structure, such as a dam, or a soft structure, such as sand nourishment. The function of the intervention should thus be retaining, which requires a height above the significant water levels. This is possible for both hard and soft structures. However, a soft structure requires large horizontal areas to reach and retain a specific height. Also, a nourishment erodes over time and may enhance sedimentation, in this case in the channel, when located closely. Therefore, for the optimisation a hard structure is chosen as the intervention measure. A schematisation of the dam is shown in Figure 8.2. The location follows the posed solution to reach the intervention objective, and will be connected to the hard boundary structures of the spillway. The length is chosen to allow for a narrowing between the dam and the opposing dune at the southern side. Furthermore, small fishing ships sail and fish throughout the tidal lake. A long dam would hinder the passage to certain areas in the tidal lake. Therefore, a length as shown in the figure is chosen. The eastern ending of the dam is deflected slightly to allow for gradual streamlines of the flow.

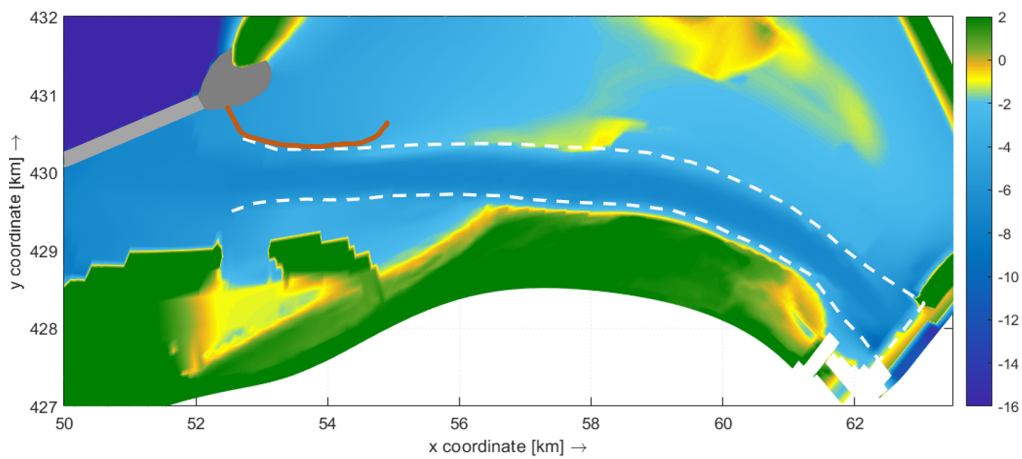

Figure 8.2: Schematic impression of the dam intervention in the tidal lake.

8.2 Optimisation results

The dam is implemented in the morphological model to calculate the effect. It will be implemented as a thin dam, which is a line between two grid cells where no calculations are performed. So, it is a line segment where no flow or change in flow is computed. The shape of the thin dam follows the schematic as good as possible, but depend on the grid cell size and orientation. The remaining input for the model remains the same, as well as the modelling time and time step. Specifics of the model input can be found in Section 5. The hydrodynamic results are discussed in Section 8.2.1, followed by the morphological results in Section 8.2.2.

8.2.1 Hydrodynamic results

The same hydrodynamic results are considered as the analysis in Section 6.1. First, the flow patterns and velocities are considered. The flow velocity patterns for ebb and flood of the situation without the dam are presented in Figure 8.3.

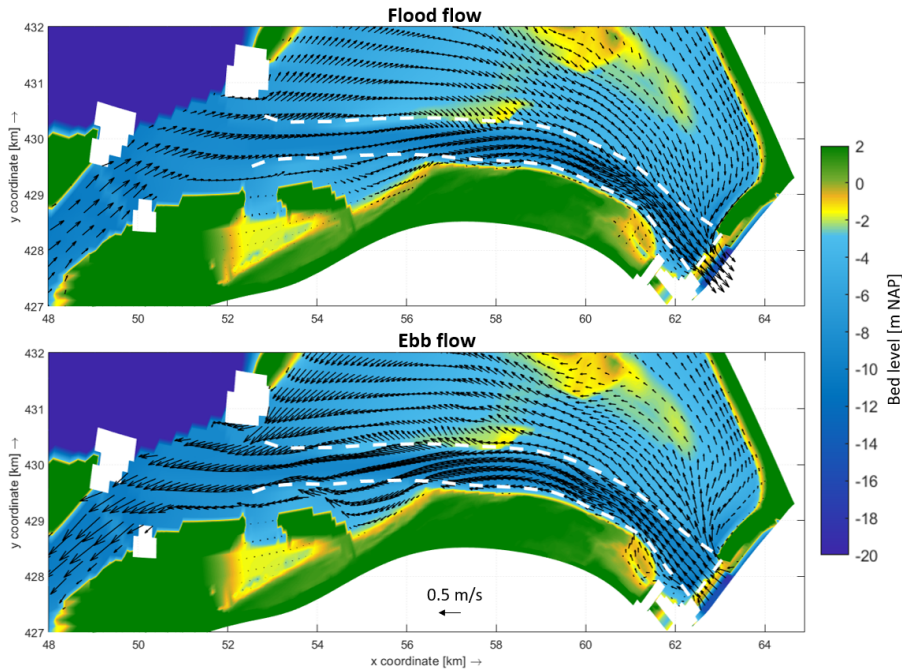

Figure 8.3: Flow velocity patterns at ebb and flood flow for Channel Concept 2, without the dam.

For the ebb and flood patterns with the dam, the same moments in time for ebb and flood are selected as the situation without the dam. These are presented in Figure 8.4. Similar patterns and velocity magnitudes are distinguished throughout the channel. The changes with respect to the situation without a dam are listed below for flood and ebb flow respectively.

- The flood flow still tends to flow in northern direction, but is deflected in direction of the channel, which is one of the purposes of the dam implementation. The flow is still significant in the transition of the spillway and the dam, which may result in erosion outside the channel contours. At the dam, there is an increase of the flow velocity and the flow is mainly longitudinal at this section in the channel. So, the increase of flow velocity and straight streamlines in the channel has been created for flood flow. At the eastern boundary of the dam, large deflections of the flow in northern direction can be observed. This can be expected with the sudden ending of the narrowing by a hard structure. This may cause large velocity gradients locally. Generally, the northern directed flow has shifted to the east, but is lower in magnitude in comparison with the original Channel Concept 2.
- Ebb flow shows somewhat similar pattern, in reverse, as flood flow. However, westerly of the channel and the dam, the flow does not follow the channel orientation and large deflections occur. This is due to the local increase of storage along the cross section, due to the inlet of the southern basin. Also, at the eastern end of the dam the deflections are significant due to the inflow from the north. Unlike for flood flow where the streamlines were straight. So, ebb flow shows large flow velocity deflections around the dam, which enhance local velocity gradients.

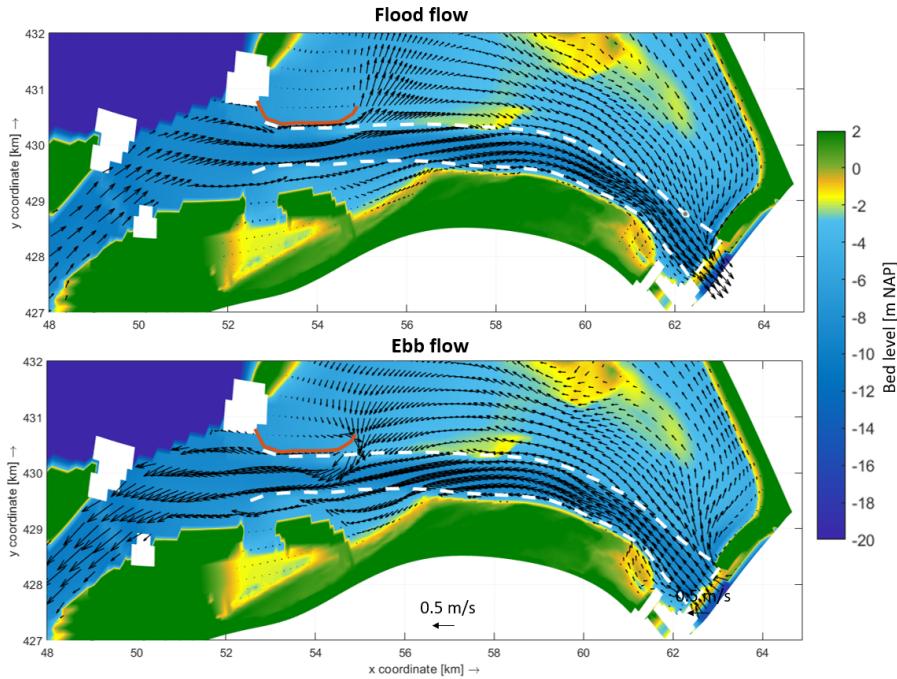

Figure 8.4: Flow velocity patterns at ebb and flood flow for Channel Concept 2, with the dam.

Quantitative flow velocities

In the navigation channel, there is a change in longitudinal and cross current velocities and gradients. A normative moment in the representative tidal cycle is selected and the flow velocities and gradients are both given in Figure 8.5. The dashed line represents the location at the centre of the dam along the channel. The same procedure as in Section 6.1 is applied where the velocities of a 10% exceedence probability are selected. Considering the longitudinal currents, the maximum flow velocities have decreased halfway the channel, which previously resulted in exceedence of the threshold of 1.5 m/s. Now, the threshold is exceeded at the western boundary of the channel. This has to do with the implementation of the dam, which has resulted in an increase of velocities locally and less deceleration of the flow. The cross currents have increased slightly at the same locations as the longitudinal currents (at the dam), which is mainly during ebb flow. A large change in cross flow is at the eastern part, where a magnitude around 0.6 m/s is reached. This is a significant increase and is due to the better guided flow through the channel. The velocity gradients for both longitudinal and cross currents have increased significantly at the dam (see dashed line), which has to do with the deflected flows at the boundaries of the dam. This may enhance sedimentation around the dam.

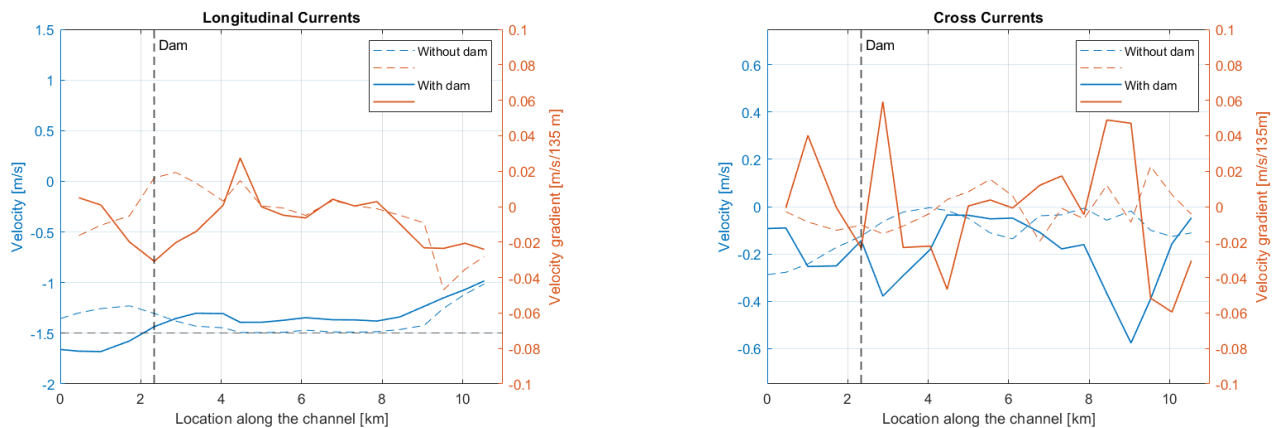

Figure 8.5: Longitudinal and cross current velocities ([m/s]) and velocity gradients ([m/s/135 m]) at a selected normative moment in the tidal cycle. The left axis corresponds to the flow velocity and the right to the velocity gradient.

8.2.2 Morphological results

The morphological results that are considered relevant to compare with the situation without the dam are the erosion and sedimentation results and the sedimented volume. Both results are considered after one year and two years of morphological modelling.

First, the erosion and sedimentation results are considered. The yearly results of Channel Concept 2 without the dam is shown in Figure 8.6.

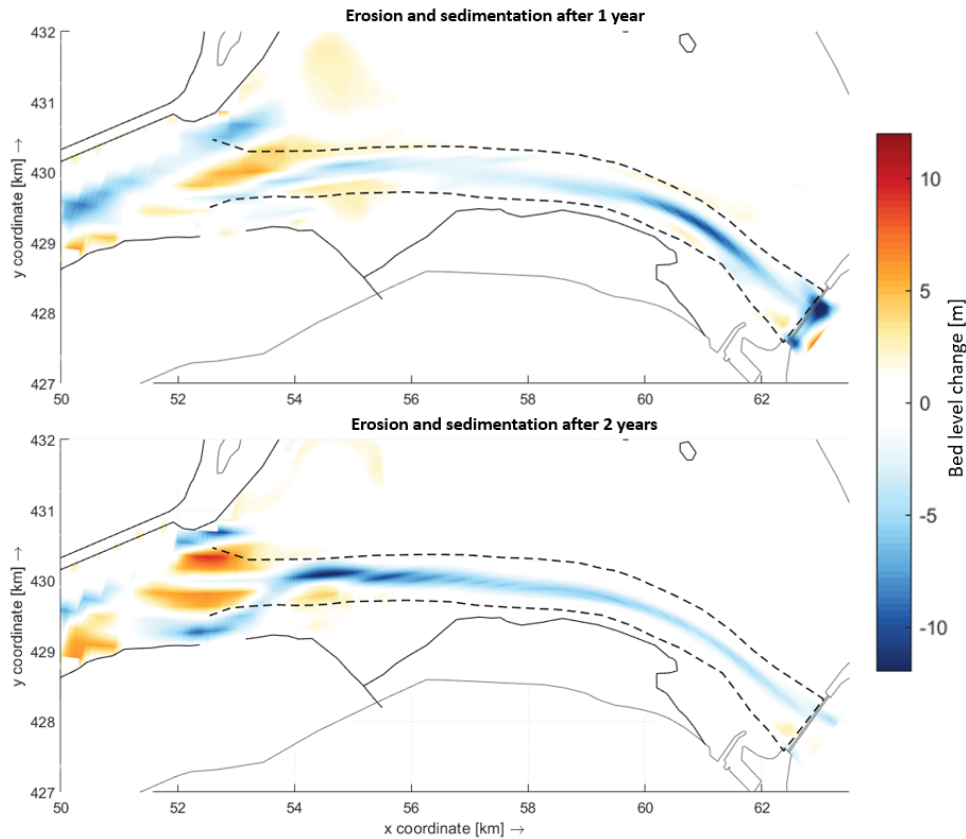

Figure 8.6: Erosion and sedimentation after one year and two years without the dam.

The results of the bed level changes without the dam are compared to those with the dam. Figure 8.7 shows the bed level change after one year and two years of modelling with the dam. The findings and comparisons between the situation with and without the dam and between the two years are listed below.

- The one year results show a completely different pattern as without the dam. The concentrated sedimentation at the dam position is not present, due to the guided flow through the channel and local increase of flow velocity. This has resulted in an eroded area instead. However, there is still sedimentation at the southwestern location of the channel ending, which is due to the deflected flow patterns, observed in the hydrodynamic results. With respect to the second year, one observes a further development of the sedimentation at the western end of the channel, which follows the same development of the situation without the dam. It is however on a smaller scale as before and thus an improvement.
- Sedimentation occurs in the bend and halfway the channel. This could be by local velocity gradient, but such large gradients were not clearly observed in the quantitative analysis. It is therefore probably due to the increase in flood flow in that part of the channel, which at the bend tends to flow in a straight line. This is observed by the eroded area, westerly of the sediment in the bend. This phenomena was previously observed at the dam and has thus been shifted

to the bend. In the second year, the sedimentation is present, but has decreased throughout the channel, as well as the erosion in the channel. The flood flow has decreased in forcing over time, due to a decrease in flood dominance of the tidal lake.

- Additional sedimentation occurs in the tidal lake, mainly by flood flow that flows north after the dam. This plume of sedimentation can be described by a flood tidal delta. Nonetheless, this delta is not present after two years of modelling, which affirms the decrease in flood flow forcing mentioned before.

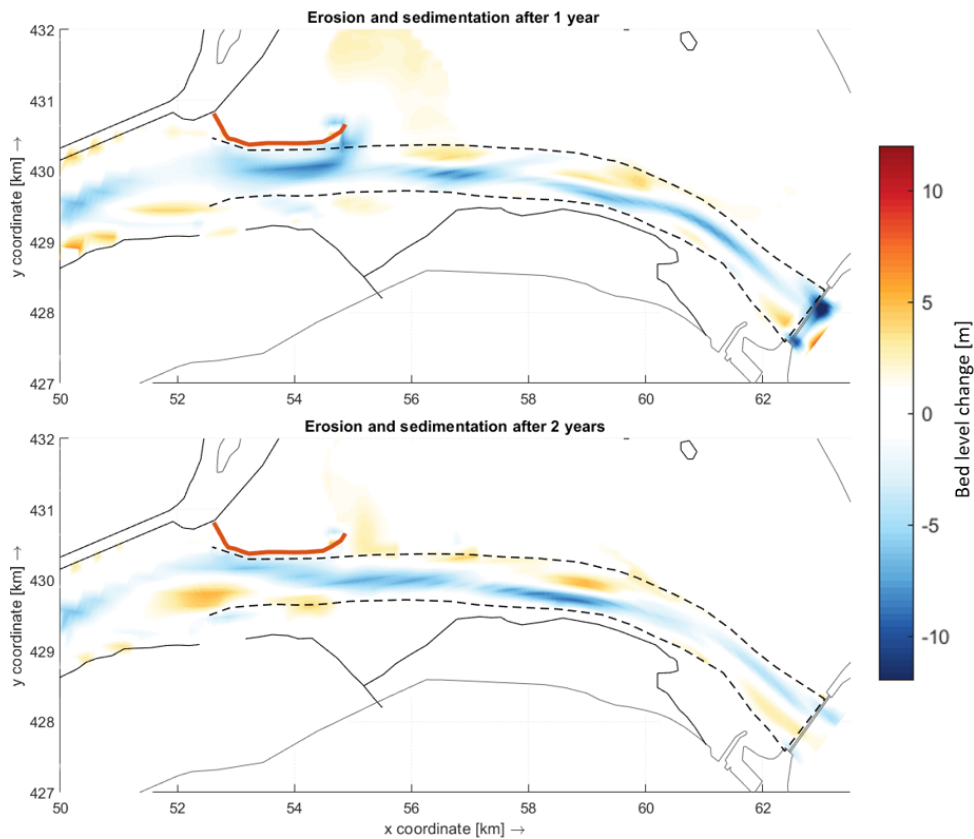

Figure 8.7: Erosion and sedimentation after one year and two years including the dam.

Sedimentation volume

The quantitative results of the sedimentation are mainly of importance to improve the application of Channel Concept 2. This due to the large contribution of the maintainability in the evaluation criteria. The sedimentation volumes in the channel at locations that exceed a depth of NAP -7.0 m are computed and listed in Table 8.1, both for the situations with and without a dam. Notice, that by implementation of a dam, the sedimentation after one year of modelling has decreased by 23%, which is a significant decrease and improvement. On the other hand, the second year shows more gradual patterns throughout the channel but does result in an increase of sedimentation. This is mainly due to the further development of the sedimentation westerly of the channel. The increase is smaller than 10%, but cannot be neglected and should be taken into account for long-term predictions. Still, it is again a decrease of 19% with respect to the second year sedimentation without a dam.

Table 8.1: Sedimentation volumes after one year and two years, with and without the dam included.

	Sedimentation without dam [Mm ³]	Sedimentation with dam [Mm ³]
Year 1	9.5	7.3
Year 2	9.2	7.8

8.3 Concluding remarks

Based on the results of the implementation of the dam, the evaluation is performed again, considering the same criteria. The channel concept has improved in the amount of sediment volume to be dredged and the repetition for maintenance. The dam has led to an increase of the magnitudes of the longitudinal and cross velocities and gradient. Therefore, the hindrance by flow is scored slightly lower than before. The total score confirms that implementing a dam is an improvement. However, the difference in scores is not considered significantly. Still, the amount of sedimentation volume is considered the most important criteria, which has improved massively by the optimisation. Hence, the optimisation is considered an improvement to the original Channel Concept 2.

Table 8.2: Revaluation scores of the criteria for Channel Concept 2 with the dam, compared to the initial concept. A shortened description of the criteria is given in the left column.

	WF	With dam		Without dam	
		Score	Score x WF	Score	Score x WF
1.1. Navigability after extreme event	0.09	4	0.37	4	0.37
1.2. Undesired location and orientation	0.02	4	0.09	4	0.09
1.3. Hindrance by flow	0.19	4	0.74	4,5	0.84
2.1. Required dredged, first year	0.28	4	1.12	3	0.84
2.2. Maintenance repetition	0.05	4	0.19	3	0.14
2.3. Required dredging, second year	0.23	3	0.70	3	0.70
3.1. Nature preservation	0.14	2	0.28	2	0.28
			3.49		3.26

The performed optimisation of the selected channel concept allows to answer the final research sub-question, which is repeated below:

How should the channel configuration be adjusted in order to meet the design requirements.

The analysis has led to the selection of Channel Concept 2 as best suited channel design. Additionally, an optimisation is proposed for the channel configuration in order to improve poorly evaluated criteria. The intervention of implementing a dam structure in the tidal lake has led to improvements to the concept. Mainly improvements with respect to maintainability are obtained, with a decrease of sedimentation after one year of modelling of 23%. The improvements are considered significantly, which has resulted in implementing the dam in addition to the construction of Channel Concept 2. Figure 8.8 shows a top view of the selected channel design including the dam, both schematically and implemented in the Delta21 design by Van Eeden (2021).

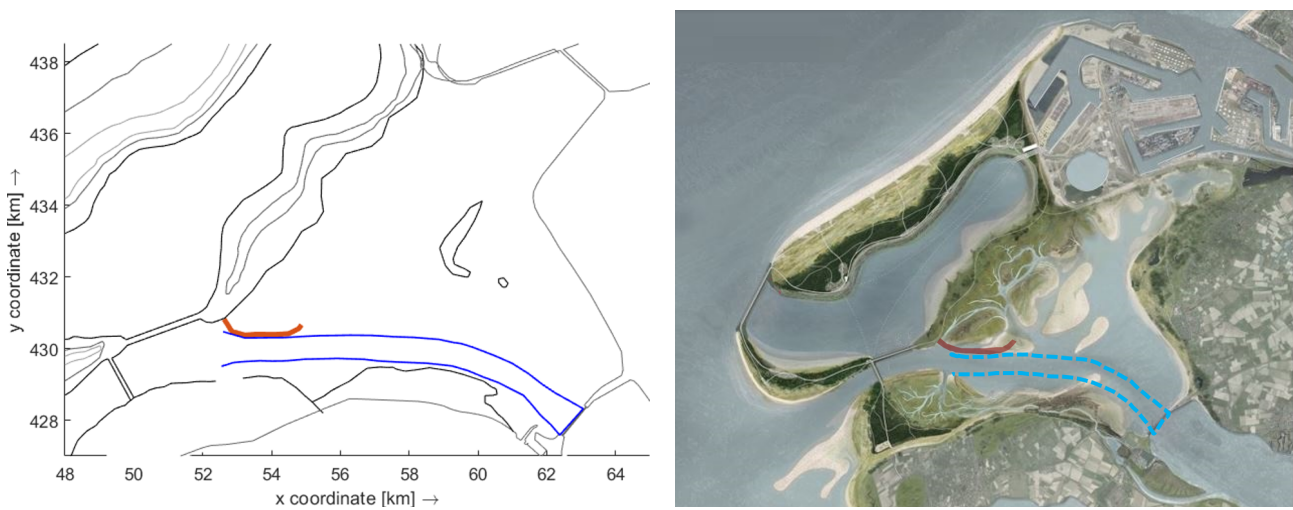

Figure 8.8: Channel Concept 2, including the dam. Left: a schematic representation. Right: implemented in the design by Van Eeden (2021).

9 Discussion

This chapter discusses the limitations of the applied numerical model (Section 9.1) and of the design process, including the assumptions (Section 9.2).

9.1 Model Limitations

9.1.1 Three dimensional modelling

The Delft3D model that is used for this research does not allow for three dimensional computations. The three dimensional effects were not implemented in previous studies, because of the computation time restrictions and many simulations. The contribution of three-dimensional effects was considered minor for those studies. However, for this research it may have been important for the results. One of the effects is by density-driven currents, caused by the interaction of fresh and salt water. Delta21 enhances this interaction even more in the tidal lake. The deeper channel and surroundings of the hard structures may be influenced by these currents. It changes the flow and consequently the sediment transport. Specifically in the bend, the helical flow could result in mixture in the water column of salt and fresh water. This could change the flow and sediment transport significantly. Additionally, implementation of more layers in the water column allows for a more detailed velocity distribution, instead of the depth averaged velocity, which was the only applicable velocity for this research. Especially in deeper parts, the velocity may differ over the water column and may give a deceptive velocity at the bed for sediment transport, when considering the depth averaged only.

9.1.2 Application of multiple sediment layers

Another limitation is the absence of interaction between different sediment layers. The used model is a one-layer model, with a certain thickness of sediment. A multi-layer model allows to implement different types of layers with different properties, such as mud which has a smaller grain size and a cohesive property. Still, the mud content in the tidal lake and specifically in the Slijkgat has increased and becomes more important to consider in computations on morphology in the area. The assumed grain size in the one-layer model does not allow for cohesive properties, but is chosen relatively low to allow partial implementation of mud properties in the model. This is considered reasonable, since there is only one layer in the model.

9.1.3 Tidal boundary conditions

The tidal boundary condition is implemented as a repeating morphological tide, which does not take into account spring-neap variations in the tidal cycle. This excludes significant flow velocities as a result of the either spring or neap tide. Especially, with the dominance of the tide, this could have resulted in higher velocities, which pose a higher repetition of threat to navigable safety. It has been implemented and calibrated by previous studies (Roelvink, 1999; Steijn et al., 2001; de Vries, 2007; Colina Alonso, 2018), where the wave and wind forcing were dominant over the tide. For this research, the effects of spring-neap tidal periods could have had a significant difference in extreme flow velocities in the channel and corresponding sediment transport. Nonetheless, the application of a morphological tide is commonly applied in such numerical models and in this case has been calibrated to a reasonable repeating tidal signal. The lower tidal velocities are higher for the morphological tide, which would result in more sediment transport at these moments.

9.1.4 Model Validation

The validation has been carried out considering previous studies by Colina Alonso (2018) and Zaldivar Piña (2020). Implementing the same input gave practically the same results. However, imple-

menting the most recent Delta21 design and a different discharge time series with respect to the input by Zaldivar Piña (2020), did not allow to compare and validate the results. As mentioned before, the Delta21 design could enhance different flow patterns and tidal behaviour with respect to another design. Also, the discharge input differs from the previous study, where a constant yearly discharge ($\approx 850 \text{ m}^3/\text{s}$) was implemented and a short-term high discharge ($\approx 3900 \text{ m}^3/\text{s}$). For this research a time series of a year has been implemented with varying discharges and an extreme discharge time series between 7500 and 10,000 m^3/s . The effect on the tidal flow by varying river discharge could thus not be validated qualitatively, which is a rather important element in this research.

9.2 Design Limitations

9.2.1 Evaluation on sedimentation and maintainability

The differences in channel orientation have resulted in diverse evaluations of the design concepts. Differences in cross-section for instance could have resulted in beneficial outcomes and allow for a more elaborate evaluation. Nonetheless, proposing different cross-sections would have meant twice or more model scenarios to be computed. Availability of computation time and storage did not allow to consider this option for this research.

9.2.2 Locally generated wind waves

The considered hydrodynamic conditions for the modelling study is excluding wave conditions by locally generated waves. The excluding of the wave conditions is based on the judgement of negligible contribution on sediment transport with respect to the tide and river discharge.

9.2.3 Nature preservation

The requirements contain a part of nature preservation, which is considered a rather important interest for specific stakeholders. These requirements implies the preservation of water quality, flora and fauna in the tidal lake and certain sand banks in the lake. Except for the latter, these preservation variables are not included in the scope of this research. Also, the applied model does not provide (reasonable) results on matters of water quality and effect flora and fauna.

9.2.4 Extreme river discharges

The maximum river discharge for the extreme conditions is assumed 10,000 m^3/s . This design discharge was chosen in order to approach the pumping capacity of Delta21. However, it turned out that the effect of such a discharge on the flow was insignificant compared to the daily conditions, where the tidal forcing is included. Implementing discharges with higher return periods would have resulted in a more normative scenario to compare with daily conditions. Nonetheless, higher return period discharges correspond to lower occurrence frequency and duration. This may on the long-term have an insignificant effect on the morphology too, comparing to the long-term daily conditions. Therefore, for this initial morphological response assessment, the design discharge choice is considered valid.

9.2.5 Morphological changes outside the tidal lake

The scope of this research is to design a navigation and discharge channel in the tidal lake. The morphological changes outside the tidal lake have not been considered in the process. Much eroded sediment is transported out of the tidal lake, considering the net sediment transport volumes in the tidal lake. Considering the results, an erosion pit directly at the seaside of the storm surge barrier is adjacent to a formed ebb tidal delta. This phenomenon has not been considered in the model

results, because it is not assumed in the evaluation. Still, it could cause hindrance for navigability of the vessels entering and leaving the tidal lake, which indirectly affects the navigability of the channel.

9.2.6 Sea level rise impact

The effect of sea level rise is not considered in this research, due to the scope of a morphological response in the first years after construction of Delta21. Sea level rise will have an impact on the morphological development and driving mechanisms on the long-term in the tidal lake as well as the closing frequency of the storm surge barrier. Nonetheless, this research is focused on the short-term morphological response. Therefore, the influence of sea level rise is ignored.

9.2.7 Delta21 design changes

This research is based on the most recent Delta21 design. Notice from previous studies that a different design or physical boundary conditions may result in significant morphological changes and development. Future designs or interventions in the research area could therefore have an impact on the morphology as well and specifically the channel. Therefore, in this design phase the results can be interpreted in a more qualitative matter, instead of fixed results. This also applies to the limitations and assumptions of the numerical model.

9.2.8 Research relevance

This research is a contribution to the overall research for the Delta21 project. The design for a navigation channel normally requires a more detailed approach of the process and system analysis. However, the application of a modelling study for the morphological response after construction has led to an additional insight in the morphological development of the channel, assuming different geometries. The additional insight allows for determining certain measures for a more detailed design. The optimisation in this research is considered such a measure, where an intervention has been introduced for improvement, based on a plausible morphological outcome.

The design of the channel requires further and more detailed research, based on the above mentioned limitations and less detailed design approach. However, the Delta21 project is still a plan in an early stage, which allows for less restricted and creative analyses. Therefore, this research is assumed relevant for the field and the Delta21 project. It introduces a design approach for the channel in the tidal lake and takes into account the mechanisms that are normative for potential failure.

10 Conclusions and Recommendations

10.1 Conclusions

The objective of this thesis is to design the navigation and discharge channel in the tidal lake of Delta21 and to research the morphological response during normal conditions and extreme conditions. This section concludes on the research and answers the research question: *What is a suitable channel configuration through the tidal lake of Delta21, considering navigation and discharge capacity?*

Answering the research question is done by presenting the answers and conclusions to the research sub-questions.

Which design requirements are applicable for the design of the navigation and discharge channel?

Functional requirements for the channel are determined as design requirements, which are based on navigability, discharge capacity, nature preservation, recreational preservation and fishery preservation. The focus of this research lays on the navigability and discharge capacity requirements. Criteria are determined which allows for evaluation in further research steps.

What is the qualitative morphological development in the tidal lake of Delta21 and what hydraulic components contribute to this development?

When implementing Delta21, the dominant drivers of sediment transport change with respect to the present-day situation. The influence of waves from open sea is assumed negligible as the dam structure of Delta21 shelters the tidal lake. Therefore, the main hydraulic components that result in sediment transport are the in- and outflow of the tide and the river discharge. The influence by wind consists only of locally generated wind waves in the tidal lake, which effect is insignificant with respect to the tide and river discharge. Within the channel, sediment transport is mainly influenced by high velocities of tidal flow and river discharge. In the present-day, the main morphological developments are forced by cross-shore wave forcing and alongshore transport. These developments will not continue when the Delta21 project is implemented, due to the absence of cross shore directed waves from open sea and blockage of alongshore sediment transport at the southern side of the dam and storm surge barrier of Delta21.

Changes in hydraulic drivers will change the morphological development. Ebb and flood currents in the tidal lake will increase, because the inlet of the estuary drastically decreases to a width equal to the opening of the storm surge barrier. This enhances a significant increase of currents velocities through the channel. The changes in the velocity field result in an increase of erosion and sedimentation in the channel, which may hinder the navigability in the channel and may change the orientation of the channel. Orientation especially changes at bends, due to possible meandering. The remaining (northern) part of the tidal lake is subjected to the change in flow direction and magnitude as well. The tide flows from a different direction through the tidal lake and results in large flow differences in the tidal lake. Large velocities will occur in the channel and relatively low in the northern part of the tidal lake. This enhances sedimentation in the northern part of the tidal lake.

How will the morphological response influence the navigability, discharge capacity and maintainability of the channel concepts?

The morphological response of the three considered channel concepts are assessed in a qualitative and quantitative matter. This response is the result of the flow in and around the channel, which are mainly influenced by changes in magnitude, direction and gradients of the flow.

The navigability is influenced greatly by the morphological response after one year of modelling under normal conditions. The tidal flow, together with river discharge, result in significant sediment

transport in the channels. Besides the erosion, sedimentation occurs throughout the channels, mainly at locations with decelerating flow or deflection of the flow. It depends on the channel configuration, which locations are subjected to sedimentation. Nonetheless, long stretches and cross-sections are sedimented throughout the channels. This results in many locations not meeting the required depth or width. The latter occurs occasionally. Channel Concept 2 has the least locations of not meeting the required depth, due to a concentrated sedimentation only. This concept also has the least sedimentation volume, approximately 20% less, compared to the other concepts. This lower volume, together with the concentrated location of the sedimentation allows for a better maintainability operation with respect to the other concepts. However, a second year modelling has resulted in a significant improvement for the initial bathymetry and Channel Concept 1, both in sedimentation patterns and volume. The long-term development for these two concepts shows a decrease in sedimentation and consequently an improvement for maintainability. Channel Concept 2 does not show a clear difference in the second year and can not be considered to either improve or worsen over time in terms of maintainability.

Influence of the discharge capacity is based on the morphological response of the extreme conditions. The flow velocities that result from the design discharge are not considered significant, comparing to normal conditions velocities. The morphological response under extreme conditions shows, for all concepts, a maximum bed level change of approximately 50 cm. This is a large amount within a week of modelling, but is in this case not considered significant, since this bed level change occurs under normal conditions as well over larger areas. Therefore, the design discharge does not influence the discharge capacity significantly. The morphological response under normal conditions does influence the discharge capacity, but not under the conditions that are at hand when the design discharge flows through the channel.

What is the most suitable channel concept?

The evaluation of the channel concepts is performed by applying criteria based on navigability, maintenance and nature preservation. The evaluation has led to the selection of Channel Concept 2 as most suitable channel in the tidal lake. This concept is characterised by the straight and short orientation. Channel Concept 2 allows for navigation most of the time, compared to the other concepts. The concept has a discharge capacity that prevents large flow velocities and accompanying gradients along the channel to occur. In terms of maintainability, it scores average in amount of dredged volume. However, the location of the sedimentation is concentrated, which is considered beneficial for maintenance operations and to pose targeted mitigation measures for sedimentation formation.

How can the preferred channel concept be optimised?

The analysis has led to the selection of Channel Concept 2 as best suited channel design. Additionally, an optimisation is proposed for the channel configuration in order to improve poorly evaluated criteria. The intervention of implementing a dam structure in the tidal lake has led to improvements to the concept. Mainly improvements with respect to maintainability are obtained, with a decrease of sedimentation after one year of modelling of 23%. The improvements are considered significantly, which has resulted in implementing the dam in addition to the construction of Channel Concept 2. The final design is presented in Figure 10.1.

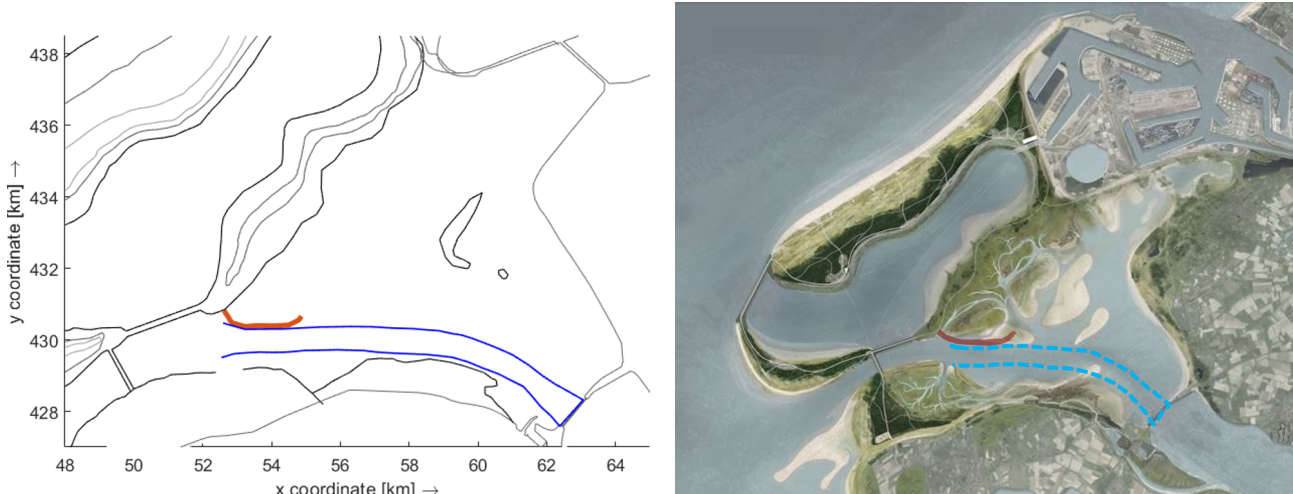

Figure 10.1: Channel Concept 2, including the dam. Left: a schematic representation. Right: implemented in the design by Van Eeden (2021).

10.2 Recommendations

In this section the recommendations for further research is described. The recommendations are based on the use and input of the model and design assumptions.

10.2.1 Recommendations for further research on model input

- Three-dimensional effects were absent in the model. By applying a three-dimensional mode in the model, the assumption of using a depth averaged velocity could be verified. This is mainly important for the deeper parts in the tidal lake (the channel). Also, the effect of density differences in the tidal lake can be introduced. The effect is mainly normative for extreme discharges through the channel, which results in a significant interaction between fresh and salt water. Another application that can be considered by three-dimensional effect is the multi bed layer implementation. This allows for implementation of several types and size of sediment. With the increasing mud content in the tidal lake in the present-day (Arcadis, 2022), this is a recommended feature to implement in further studies on the channel design and the morphology in the tidal lake. Three-dimensional effect do require more computation capacity, time and storage of the results. This should be considered when applying such a mode.
- The implementation of a spring-neap tidal variation in the tidal signal of the offshore boundary is recommended for further research, when using this particular model. This allows to have a representative tidal forcing, including extreme tidal variations. The implementation of a varying tidal signal requires a varying time series as input, which well represents the tidal signal at the offshore boundary.
- It is recommended for further research on morphological calculations in the channel, to implement a WAVE-model that considers the morphological effect of locally generated wind waves. This can be applied by implementing normative wind conditions in the WAVE-model and run the FLOW-model coupled with the WAVE-model. This too requires a larger computation capacity, but the use of such a Delft3D coupled model is feasible.

10.2.2 Recommendations on design aspects

- The long-term morphological development in this research is restricted to two years. It is recommended to simulate the morphological development of several years. This allows to verify the conclusions on required maintenance over a longer period. This is possible for the selected channel concept and the other concepts too. The latter requires an elaboration of the criteria and the evaluation process.
To account for further long-term conditions, it is recommended to implement the effect of sea level rise on the tidal lake. This requires an analysis on the expected climate change scenario, with the corresponding sea level rise at a specific moment in the future.
- There has been no consideration of different cross-section designs when designing the concepts. The chosen cross-section of both concepts fulfils the requirements, but there has been no further consideration of optimisation for a different cross-section. This requires twice or more modelling computations, which was not considered for this research. However, it is recommended to investigate different cross-section areas. This could be by selecting only Channel Concept 2 or all concepts. The chosen cross-section is quite conservative and large. A more optimised cross-section may result in reduction of sedimentation volume.
- The design discharge for the extreme conditions turned out not to result in significant hydrodynamic and morphological results with respect to normal conditions. Therefore, it is recommended to expand the methodology of the extreme conditions modelling to higher discharges, such as 15,000 m³/s to 20,000 m³/s which resembles the capacity of the Haringvliet sluices and the spillway of Donkers (2021). This requires an analysis of occurring discharges and the accompanying return periods with respect to the Rhine and Meuse discharges.
- The requirements state an importance for nature preservation. The tidal lake is located in a Natura2000 area, which requires preservation of the flora and fauna in the area and the ecological value. The scope of this research did not allow for a quantitative and qualitative assessment on the matter. It is recommended to have further research on these requirements. This can be performed by making a qualitative assessment, considering the influence of construction of a channel and rate of bed level change in certain areas on the flora, fauna and ecological value.

References

- Arcadis. (2022). *Onderzoek aanzanding kust Haringvlietmonding*. Arcadis. (Technical report)
- Balla, A., Blaas, M., van Boheemen, Y., ten Brinke, W., Broekhuizen, A., Burgers, S., R. de Goederen, ... van Zetten, R. (2019). *Het verhaal van de Rijn-Maasmonding*. .
- Berke, L., & Lavooij, H. (2021). *Het plan*. <https://www.delta21.nl/het-plan/>. (Online; accessed on 20 November 2021)
- Berke, L., Lavooij, H., Tonneijck, M., de Boer, H., & Vrijling, H. (2017). *Delta21 en energie*. Delta21. (Technical report)
- Berke, L., Lavooij, H., Tonneijck, M., de Boer, H., & Vrijling, H. (2018). *Delta21 en waterveiligheid*. Delta21. (Technical report)
- Blokland, P., Ferguson, H. A., & Kuiper, H. (1970). *The haringvliet sluices*. Rijkswaterstaat Communications.
- Bosboom, J., & Stive, M. J. F. (2021). *Coastal dynamics*. TU Delft Open.
- Cleveringa, J. (2008). *Ontwikkeling sedimentvolume overzicht van de beschikbare eems-dollard en het groningen wad*. Deltares. (Technical report)
- Colina Alonso, A. (2018). *Morphodynamics of the haringvliet ebb-tidal delta*. Master's Thesis, Delft University of Technology.
- Deltares. (2021). *Delft3D-FLOW. Simulation of multi-dimensional hydrodynamic flows and transport phenomena, including sediments*. Deltares. (User Manual)
- de Vries, M. J. (2007). *Morphological modelling of the haringvlietmonding using Delft3d*. Master's Thesis, Delft University of Technology.
- Donkers, D. H. (2021). *Conceptual design of the spillway into the energy storage lake of delta21*. Master's Thesis, Delft University of Technology.
- DVS, & Rijkswaterstaat. (2008). *Vaarwegen in Nederland*. Naslagwerk.
- Eelkema, M. (2013). *Easter scheld inlet morphodynamics*. PhD Thesis, Delft University of Technology.
- Elias, E. P. L., & van der Spek, A. J. F. (2014). *Grootschalige morfologische veranderingen in de Voordelta*. Deltaris. (1964-2013 werkdocument)
- Elias, E. P. L., & van der Spek, A. J. F. (2021). Half a century of morphological change in the haringvliet and grevelingen ebb-tidal deltas (sw netherlands) - impacts of large-scale engineering 1964–2015. *Marine Geology*, 432, 106404.
- Elias, E. P. L., van der Spek, A. J. F., & Lazar, M. (2016). The 'voordelta', the contiguous ebb-tidal deltas in the sw netherlands: large-scale morphological changes and sediment budget 1965–2013; impacts of large-scale engineering. *Netherlands Journal of Geosciences*, 96(3), 233-259.
- ENW. (2021). *Hoogwater 2021 feiten en duiding*. Expertisenetwerk waterveiligheid.
- IPCC. (2021). *Climate change 2021: The physical science basis. contribution of working group i to the sixth*.
- Klijn, F., Hegnauer, M., Beersma, J., & Sperna Weiland, F. (2015). *Wat betekenen de nieuwe klimaatscenario's voor de rivierafvoeren van Rijn en Maas?* . Deltares and KNMI.

- KNMI. (2014). *KNMI' klimaatscenario's voor nederland*. Ministerie van Infrastructuur en Waterstaat.
- KNMI. (2021). *KNMI klimaatsignaal'21*. Ministerie van Infrastructuur en Waterstaat.
- KNMI. (2022). *Daggegevens van het weer in nederland*. (data retrieved from Koninklijk Nederlands Meteorologisch Instituut <https://www.knmi.nl/nederland-nu/klimatologie/daggegevens>)
- Koomans, R. (2001). *Bodemsamenstelling in de monding van het Haringvliet. Sediment karakterisatie en data analyse*. MEDUSA Explorations BV.
- LenW. (2015). *Ons water in Nederland, nieuw nationaal waterplan 2016-2021*. Ministerie van Infrastructuur en Milieu.
- MacArthur, J. (1997, December). Stakeholder analysis in project planning: origins, applications and refinements of the method. *Proj. apprais.*, 12(4), 251–265.
- Marinetraffic. (2022). *Details ships*. <https://www.marinetraffic.com/nl/ais/home/centerx:-2.0/centery:55.3/zoom:7>. (Online; accessed on 13 July 2022)
- McBride, M., Boll, M., & Briggs, M. J. (2014). Harbour approach channels—design guidelines. *PIANC Report No. 121*.
- Molenaar, W., & Voorendt, M. (2020). *Hydraulic Structures - General lecture notes*. Delft University of Technology.
- Natura2000. (2018). *Ontwerp-wijzigingsbesluit, habitatrichtlijngebieden vanwege aanwezige waarden*. Ministerie van Landbouw, Natuur en Voedselkwaliteit.
- Noordhuis, R. (2017). *Het haringvliet na de kier*. Deltares. (Technical report)
- ODA. (1995). *Guidance note on how to do stakeholder analysis of aid projects and programmes*. Overseas Development Administration.
- Rijkswaterstaat. (1972). *Het deltaplan in het licht van de laatste ontwikkelingen*. Rijkswaterstaat.
- Rijkswaterstaat. (1984). *Lozingsprogramma haringvlietsluizen '84*. Rijkswaterstaat Directie Benedenrivieren.
- Rijkswaterstaat. (1986a). *Ontwerpnota Stormvloedkering Oosterschelde boek 1 totaalontwerp en ontwerpfilosofie Deelnota 1: Totaalontwerp*. Ministerie van Infrastructuur en Waterstaat.
- Rijkswaterstaat. (1986b). *Ontwerpnota Stormvloedkering Oosterschelde boek 1 totaalontwerp en ontwerpfilosofie Deelnota 4: Beschrijving van het Ontwerp*. Ministerie van Infrastructuur en Waterstaat.
- Rijkswaterstaat. (2008). *Notitie scheepvaart, onderdeel verkenning "Grevelingen water en getij"*. Ministerie van Verkeer en Waterstaat.
- Rijkswaterstaat. (2016). *Natura 2000 Voordelta, Beheerplan*. Ministerie van Infrastructuur en Milieu.
- Rijkswaterstaat. (2020). *Multibeamlodingen - haringvliet haringvlietsluizen stortebedden*. (Tech. rep. Servicedesk Data)
- Rijkswaterstaat. (2020). *Richtlijnen vaarwegen 2020*. Ministerie van Infrastructuur en Waterstaat.
- Rijkswaterstaat. (2022a). *Afvoerdata haringvlietsluizen 1980-2020*. (data retrieved from Waterinfo <https://waterinfo.rws.nl>)

- Rijkswaterstaat. (2022b). *Vaklodingen*. (data retrieved from OpenDap Deltares https://opendap.deltares.nl/thredds/catalog/opendap/rijkswaterstaat/vaklodingen_new/catalog.html)
- Roelvink, J. (1999). *Kleinschalig morfologisch onderzoek MV2 fase 1b: Gevoeligheidsonderzoek*. WL Delft Hydraulics, TUD. (Technical report)
- RVO. (2022). *Gids van Vissersvaartuigen*. Ministerie van Landbouw, Natuur en Voedselkwaliteit.
- Sha, L., & Berg, J. H. (1993, 01). Variation in ebb-tidal delta geometry along the coast of the netherlands and the german bight. *J. Coastal Res.*, 9, 730-746.
- Steijn, R., Eysink, W., van Holland, G., & van de Graaff, J. (2001). *Bandbreedte morfologische Effectvoorspelling - MV2: Een onderzoek ten behoeve van natuurtypering*. Alkyon, WL Delft Hydraulics, TUD. (Technical report)
- TenderGuide. (2020). *Onderhoudsbaggerwerkzaamheden slijkgat*. (data retrieved from TenderGuide <https://www.tenderguide.nl/aanbesteding/284944-onderhoudsbaggerwerkzaamheden-slijkgat?sector=165>)
- Timmermans, J., & Voorendt, M. (2019). *Delta21, een concept als voorbeeld van integraal ontwerp en interdisciplinaire samenwerking*. (<https://www.flowsplatform.nl/het-delta21-concept-als-voorbeeld-van-integraal-ontwerp-en-interdisciplinaire-samenwerking-1601646802225>)
- Tönis, I., Stam, J., & van de Graaf, J. (2002). Morphological changes of the haringvliet estuary after closure in 1970. *Coastal Engineering*, 44(3), 191-203. Retrieved from <https://www.sciencedirect.com/science/article/pii/S0378383901000266> doi: [https://doi.org/10.1016/S0378-3839\(01\)00026-6](https://doi.org/10.1016/S0378-3839(01)00026-6)
- UN. (2015). *Paris agreement*. United Nations.
- Van Holland, G. (1997). *Hydrodynamica en morfodynamica van de monding van het Haringvliet*. Master's Thesis, Delft University of Technology.
- Van Eeden, E. (2021). *A new dynamic landscape for the Haringvliet*. Master's Thesis, Delft University of Technology.
- Van Rijn, L. C. (2007a). Unified view of sediment transport by currents and waves. i: Initiation of motion, bed roughness, and Bed-Load transport. *Journal of Hydraulic Engineering*, 133(6), 649–667.
- Van Rijn, L. C. (2007b). Unified view of sediment transport by currents and waves. II: Suspended transport. *Journal of Hydraulic Engineering*, 133(6), 668–689.
- van Vessem, P. (1998). *Morfologie en kwaliteit. Morfologie Monding Haringvliet*. Technical Report, RIKZ-98.016.
- Verschoor, B. L. (2023). *The Delta Barrier - A climate robust preliminary design of the Delta21 storm surge barrier*. Master's Thesis, Delft University of Technology.
- Wais, P. (2017). A review of weibull functions in wind sector. *Renewable and Sustainable Energy Reviews*, 70, 1099-1107. Retrieved from <https://www.sciencedirect.com/science/article/pii/S1364032116310565> doi: <https://doi.org/10.1016/j.rser.2016.12.014>
- Young, I., & Verhagen, L. (1996). The growth of fetch limited waves in water of finite depth. part 1. total energy and peak frequency. *Coastal Engineering*, 29(1), 47-78. Retrieved from <https://www.sciencedirect.com/science/article/pii/S0378383996000063> doi: [https://doi.org/10.1016/S0378-3839\(96\)00006-3](https://doi.org/10.1016/S0378-3839(96)00006-3)

Zaldivar Piña, M. I. (2020). *Stability of intertidal and subtidal areas after delta21 plan*. Master's Thesis, Delft University of Technology.

A Argumentation of the requirements

A.1 Navigability

The vessels that are currently using the Voordelta and especially the Slijkgat are considered for the normative vessel of the channel design. These vessels are mostly fishing ships and recreational vessels. After construction of Delta21, it is assumed that the type of vessels that sail in the area will not change drastically, which is why the current vessels are assumed to determine the design vessel. In order to use the design vessel for designing the channels, the guidelines for waterways by Rijkswaterstaat 2020 will be used and, if necessary, the PIANC (McBride et al., 2014).

The fishing ships that sail in the area are registered by Rijksdienst voor Ondernemend Nederland 2022 and are considered to determine the normative vessel. It concerns the ships which are allowed in the ports of Stellendam, Goedereede (Ouddorp) and Goedereede. The locations of these ports are given in Figure A.1, with the villages that correspond to these port names indicated. For instance, the ships that correspond to Goedereede are stationed in Goedereede (Stellendam), because they cannot reach the village of Goedereede anymore. Now these vessels are stationed at Stellendam as well as the ships from Stellendam. The figure also indicates the sailing route that the vessels sail, which make use of the Slijkgat.

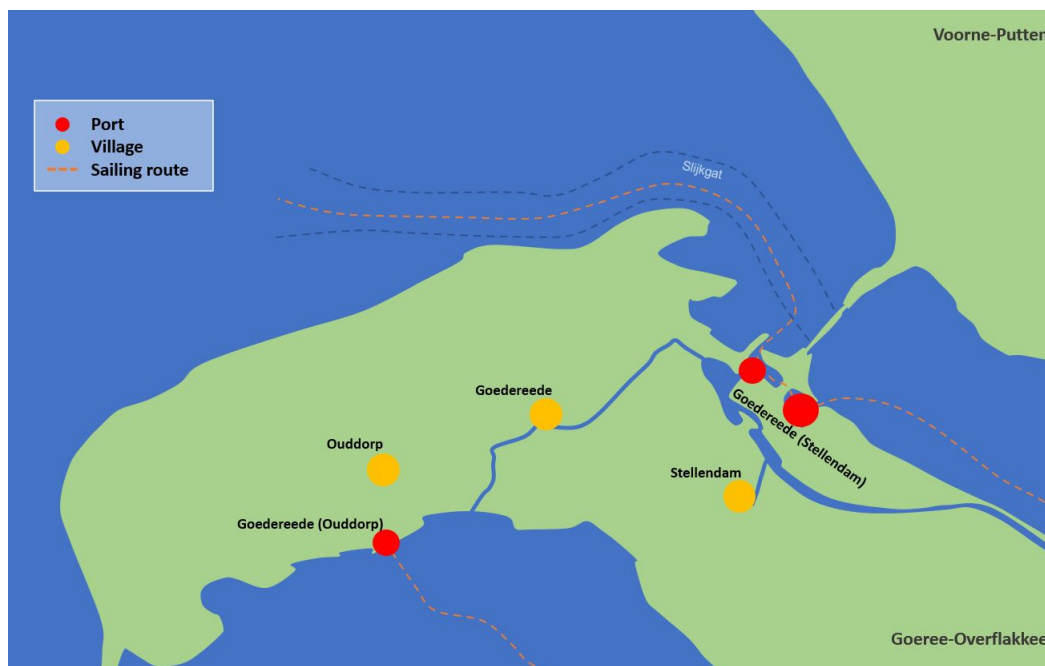

Figure A.1: Goeree-Overflakkee overview with indicated villages and ports which house the fishery ships that make use of the Slijkgat.

Most of the vessels are not allowed to fish in the Voordelta, due to the regulation, set by Natura2000 and the government (Rijkswaterstaat, 2016). The maximum power allowance of a fishing ship in the Voordelta is 260 hp, which corresponds to quite minor vessels. Still, the larger vessels sail through the Goereesesluis and the Slijkgat to sail outside of the Voordelta, so these vessels should be considered for the design. The normative vessel is determined by normative parameters, which are used for the channel design. These parameters are: width, length, draught and maximum velocity. Where the normative maximum velocity is the smallest maximum velocity for which the ship can sail through opposing longitudinal flow. With the normative parameters, suitable channel designs can be made. The fishing ships are considered for determining the normative parameters of the normative vessel. This, because of the economical dependence of the fishing companies, unlike the recreational ships, larger size and mostly lower sailing velocities. The normative vessels for which the home port is one of

the three indicated ports in Figure A.1, are listed in Table A.1, with the important parameters indicated. Also, the CEMT-class that is allowed to sail through the Goereesesluis is given, which is class Va (DVS & Rijkswaterstaat, 2008). These vessels should be able to sail through the channel as well and the dimensions are taken from the guidelines for waterways (Rijkswaterstaat, 2020). The design vessel with the dimensions follow from the listed vessels and are indicated as well. The maximum velocity of a CEMT-class ship is not given, therefore a normative velocity of the other vessels is chosen.

Table A.1: Normative vessels and CEMT-class Va dimensions for determining the dimensions of the design vessel for the channel. Additionally the normative vessel is indicated with the corresponding important dimensions (Marinetraffic, 2022).

	Width [m]	Length [m]	Draught loaded [m]	Maximum velocity [kn]
OD1 Maarten-Jacob	8.50	42.35	4.80	11.70
GO5 Ora Et Labora	8.00	42.00	5.00	11.00
SL13 Zeewolf	4.00	8.00	1.50	5.50
CEMT-class Va	11.40	135.00	4.00	-
Design vessel	11.40	135.00	5.00	5.50

As mentioned before, the guidelines for waterways are applied to design for the navigability of the channel. First, a waterway profile should be chosen, which is done assuming the intensity of vessels per year. Passing data at the Goereesesluis at Stellendam is used for this. It turns out that the number of recreational vessels are normative over commercial shipping, circa 21,000 over 3,000 (Rijkswaterstaat, 2008). This results in a 'normal' type of waterway profile. To allow two way passing and prevent congestion, a double lane will be assumed in this phase of the channel design.

Channel width

The width of the channel design is determined following the guidelines as well. The final width is determined by a combination of factors that could cause problems for the vessels, which is expressed in an enumeration of several widths. To give a first impression, Figure A.2 is provided to show which elements are at least necessary to take into account for the channel width determination. The indicated heights correspond to the level of the indicated widths.

- W_d is the minimum needed depth for the loaded normative vessel to sail.
- W_t is the width, spread to the draught of the loaded normative vessel.
- Δ_w is an additional width for the unloaded normative vessel to take into account cross displacement as a result of crosswind.

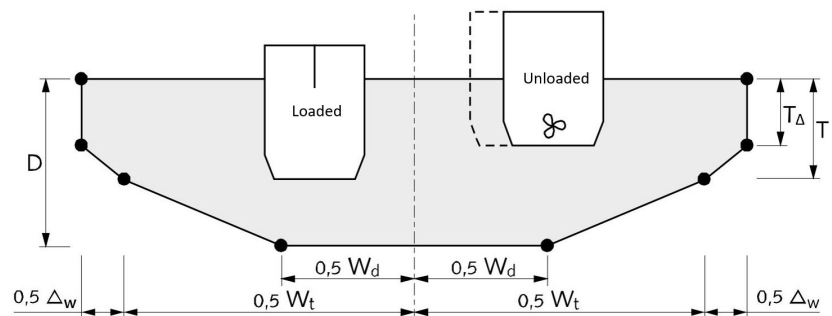

Figure A.2: Indication of design channel widths and heights by Rijkswaterstaat (2020).

Notice from the figure that this profile corresponds to an inland waterway design. This may not completely be in line with this research, due to the absence of the land containment by quays or dikes and presence of tidal flats at a depth of T_Δ . However, besides the land containment, the same procedure in determining the channel width is valid and therefore the use of these guidelines.

By respecting the guidelines for a normal waterway profile, one obtains a W_d and W_t of respectively 2B and 4B. With B the width of the normative vessel. However, due to the relatively small width of the normative vessel, the widths for the design are smaller than the minimal required waterway width which corresponds to a Va ship profile. Therefore, the minimal required widths are applied for this design. An additional width that should be included is the influence of longitudinal and cross flow. It depends on the longitudinal flow velocity in the channel that may occur when sailing, which in this case is quite large as a result of the tide. The additional width is based on the guidelines of PI-ANC, which is defined well for channels in coastal regions, unlike the Richtlijnen vaarwegen. The added width is determined by expected current velocities on a specific ship. To be within the defined ranges of velocities and to assume relatively slow vessels, an additional width (Δ_{flow}) of 1.0B and 0.2B for respectively the effect of longitudinal and cross currents is determined.

An overview of the widths and the numerical values is given in Table A.2, as well as the total required width for navigability.

Table A.2: Numerical values for design widths, following the guidelines for waterways.

	Width [m]
W_d	22.8
W_t	45.6
Δ_w	14
Δ_{flow}	13.7
Total	73.3

Added bend width

The above widths are for a straight waterway. A bend in a waterway requires manoeuvrability of the vessels and sailing corrections. This requires locally additional width in the channel. The additional width is determined by applying the Richtlijnen vaarwegen, for the initial bathymetry. For new concepts it is reported in Chapter 4. The addition is defined for loaded and unloaded vessels, where the loaded width (Δ_{B1}) is added on the depth "T" in Figure A.2 and unloaded width (Δ_{B2}), together with loaded, on a depth "T $_{\Delta}$ ". The additional widths are defined below, with C_i a constant, L the vessel length and R the radius of the bend.

$$\Delta_{B1} = \frac{C_1 L}{R}, \quad \Delta_{B2} = \frac{C_2 L}{R}$$

By considering CEMT class Va for the constants and assuming significant flow velocities in the channel, results in a additional loaded and unloaded width of respectively 4.45 m and 7.63 m. Again, this holds for the geometry of the initial bathymetry concept. So, at the bend W_t is added by a length of 4.45 m.

Channel depth

The draught of the design vessel determines the channel depth that is required for navigability. Table A.1 provides a normative draught of 5.00m for the channel. This depth corresponds to the denoted depth "T" in Figure A.2 for clarification. Keel clearance and the effect of the (low) tide should be included to reach the required depth (D). The guidelines prescribe for commercial shipping, in this case the normative vessels of the fishing companies, to include a keel clearance of 10%. This results in a depth of 1.1T.

To allow the fishing ships to sail under every tidal condition, the LAT level is added to the determine the total required depth for the channel design. It turns out that the LAT is a level of NAP -1.22m. Together with the other depth elements, a design depth at NAP -6.72m is reached. This depth is of course quite detailed to dredge perfectly over the whole channel area. So, to allow for irregularities in the dredging works, a design depth at NAP -7.0m is assumed for the design.

Allowed flow velocity

The vessels have a certain power to sail and a corresponding velocity that can be reached. Under daily conditions, ships should be able to sail against the longitudinal flow that may occur and handle cross current flow. These conditions are as a result of the tide and major discharges. The specifics on the

discharges and the capacity of the channel will follow in the next section. The maximum longitudinal and cross flow that is allowed for the design is assumed less than the maximum velocity of the design vessel. This, because of the assumption that the power of the vessel cannot reach the velocity of 2.8 m/s to sail against. For the allowable flow velocities the PIANC is applied, because of the more elaborate application of these guidelines on a channel in a coastal area. Due to the assumption of large velocities to occur, one considers for both currents a moderate allowable velocity to occur. The accompanying additional widths have already been included. For the longitudinal currents this results in a maximum velocity of 3.0 kn (≈ 1.5 m/s) and for the cross currents 1.5 kn (≈ 0.75 m/s). Nonetheless, to account for exceptions in occurring flow velocities, the assumption has been made to allow velocities to exceed the given maxima for a probability of occurrence of 0.1. This in terms of providing safe navigation through the channel. A repetitive occurrence of the exceedence of the maxima throughout the channel is considered as a dangerous situation.

A.2 Discharge capacity

The requirements for the discharge capacity represents a less detailed approach than for the navigability. There are no specific guidelines for a discharge capacity requirement to meet as was the case for navigability. The main requirement is set to design a channel where flow velocities do not exceed substantially, given an incoming discharge into the tidal lake. In this research a discharge of 10,000 m³/s is used, which resembles the maximum pump capacity of Delta21, when the spillway is open and the barrier closed. In this situation it is assumed that there is no navigability in the tidal lake due to closure with the sea. Also small fishing ships are not considered to sail in the tidal lake for these extreme conditions.

The tidal lake should allow a 10,000 m³ discharge to flow to the energy storage lake, from where it can be pumped to the sea. Therefore, this discharge is used as a design discharge for the channel, which should allow this discharge to flow to the spillway in a short period of time.

The discharge of 10,000 m³/s is used as a measure to determine the cross sectional area of the channel, which results in a maximum depth averaged flow velocity that fits the allowed flow velocity. This chosen discharge meets with high certainty the scenario with a closed storm surge barrier and open spillway, which was stated in Section 1.2.2. This specific discharge corresponds approximately to a return period of ten years (Klijn et al., 2015). In terms of morphological changes and dredging works after extreme events, such return periods are considered normative in this research. Higher discharges (with higher return periods) could occur as well, but have a smaller probability of occurrence. Also, this discharge is considered for the design of the channel, so for higher discharges there is the remaining storage capacity of the tidal lake that could moderate the discharge. The higher discharges could result in higher velocities than allowed.

In case of a closed storm surge barrier and open spillway, there is no restriction on flow velocities for navigability. Nonetheless, it is still a channel that is not to morphologically change too much as a result of high discharges. Therefore, for the discharge capacity, a large cross-sectional area is assumed for storage and a maximum flow velocity through that cross-section. The guidelines for waterways are defined for a maximum flow velocity of 2.5 m/s. For a maximum allowable flow velocity through the channel, assuming the design discharge, a depth averaged velocity of 2.0-2.5 m/s is assumed. Note, that the maximum velocity in the extreme conditions is only due to the discharge, when considering the storm surge barrier closed. So there is no tidal influence in this case that contributes to higher depth averaged velocities. A straightforward calculation to obtain a cross sectional area, using the design discharge and the maximum allowed velocity results in an area range of 4000 to 5000 m².

B Wind wave analysis

The wave conditions for this research are only considered by locally generated wind waves in the tidal lake. The velocities that result from these generated waves should be translated to sediment transport. It is not known beforehand if the effect by these waves are normative with respect to the tidal influence and the river discharge. Also, a WAVE-model should be constructed besides the used FLOW-model in Delft3D, which makes the model more complex and increase computation time and storage. Therefore, first a rough calculation has been carried out to determine the significance of the orbital velocities that are caused by the waves with respect to the other hydrodynamic forcings. Determining the wave heights, generated by wind, is done by using the Bretschneider equations, modified by Young & Verhagen (1996). The wave height expression is given in Equation (B.1)

$$\tilde{H} = \tilde{H}_{\infty} \left\{ \tanh(0.343\tilde{d}^{1.14}) \tanh \left(\frac{4.41 \cdot 10^{-4} \tilde{F}^{0.79}}{\tanh(0.343)\tilde{d}^{1.14}} \right) \right\}^{0.572} \quad (\text{B.1})$$

$$\tilde{H} = \frac{gH_{m0}}{U_{10}^2}, \quad \tilde{F} = \frac{gF}{U_{10}^2}, \quad \tilde{d} = \frac{gd}{U_{10}^2}$$

Where:

F [m] : Fetch

d [m] : Average water depth over the fetch

U_{10} [m/s] : Wind velocity at a height of 10m above the water line

\tilde{H}_{∞} [-] : Dimensionless deep water wave height (= 0.24)

\tilde{H}_{m0} [m] : Significant wave height, from wave spectrum ($H_{m0} \approx H_s$)



Figure B.1: Overview of normative fetches for the dominant wave directions

For calculating the wave height, the wind distributed data from Section 3.2 is used. The dominant fetch lengths for every wind direction is selected for the fetches and corresponding mean depths (see Figure B.1). These fetches are selected for the effect on the channel concepts instead of the total tidal lake and are considered normative for the design. Notice, that the western fetch is significant with respect tot the other direction fetches. Together with a relatively similar wind distribution, the western wind direction is considered normative for the wind wave analysis on the morphology of the different channel concepts. Therefore, to translate the wind waves to sediment transport, the generated orbital velocity by the waves are assumed as an indication of the sediment transport forcing. The expression of the depth-uniform velocity amplitude in shallow water is used to indicate the order of magnitude of the velocity by the wind waves (Bosboom & Stive, 2021). The amplitude is used in order to obtain the maximum orbital velocity by a certain depth and wave height.

$$\hat{u} = \sqrt{gd} \frac{H}{2d} \quad (\text{B.2})$$

The orbital velocities that correspond to 1, 10, 100 and 1000 year return period are computed and listed in Table B.1, as well as the corresponding wave height from the Bretschneider equation and the wind speeds. For the mean depth, the minimum depth of the channel concepts is chosen, which orientation follows the fetch direction.

Table B.1: Orbital velocity calculation parameters for western wind direction and four return periods. Fetch and mean water depth are constant and are respectively: $F=7200\text{m}$ and $d=7\text{m}$.

	U_{wind} [m/s]	H_s [m]	\hat{u} [m/s]
R=1	6.05	0.32	0.19
R=10	16.63	0.95	0.56
R=100	21.82	1.26	0.74
R=1000	25.72	1.48	0.88

When considering the velocity amplitudes in the table, there is a gradual increase for the longer return periods. There are thus no significant increases of the orbital velocity in heavy storm conditions. With respect to the tidal velocities, the wave velocities are only a small percentage of the maximum tidal in- and outflow. For the high return periods, the storm surge barrier is assumed closed, so no tidal in- and outflow, which means there is no forcing by the main driver for high velocities. Therefore, for high return periods, the wind waves are not considered significant for sediment transport with respect to the tidal flow and discharge in the daily conditions. Also, the occurrence of these wind speeds are of a very short time (a few hours), with respect to the daily conditions. So, in terms of morphological changes, such short time and insignificant orbital velocities are not assumed normative.

The velocities that have a high occurrence rate are of more importance. The one year return period for the western wind speeds results in an orbital velocity of 0.19 m/s, which is around 10% of the maximum tidal velocity. This too is not considered a significant magnitude of a velocity in and around the channel, even tough it could happen more often. Therefore, the effect by wind waves are not considered normative at all for the modelling study. This allows to perform the modelling study without adding a WAVE-model to the FLOW-model, which reduces the computation time and required storage of the modelling output. So, the hydrodynamic component of wind waves is not considered normative in this research for the morphological development.

C Validation results

This appendix contains presented results of two validation steps, which support the discussed validation in Section 5.5. The first step is the comparison of the water level and flow velocity signals at key locations. The same locations are considered except for the "tidal inlet", which was not available in the provided Delft3D model. The water levels show the same signal and heights in both runs. The velocity signals have a similar shape as well, but only the "Slijkgat channel" signal is slightly lower in magnitude for this research validation run. This is probably due to application of a different bathymetry as input, because the remaining locations have the same magnitude. These results show almost the same results as the studies by (Zaldivar Piña, 2020) and (Colina Alonso, 2018) and thus the boundary conditions for the model input are considered valid.

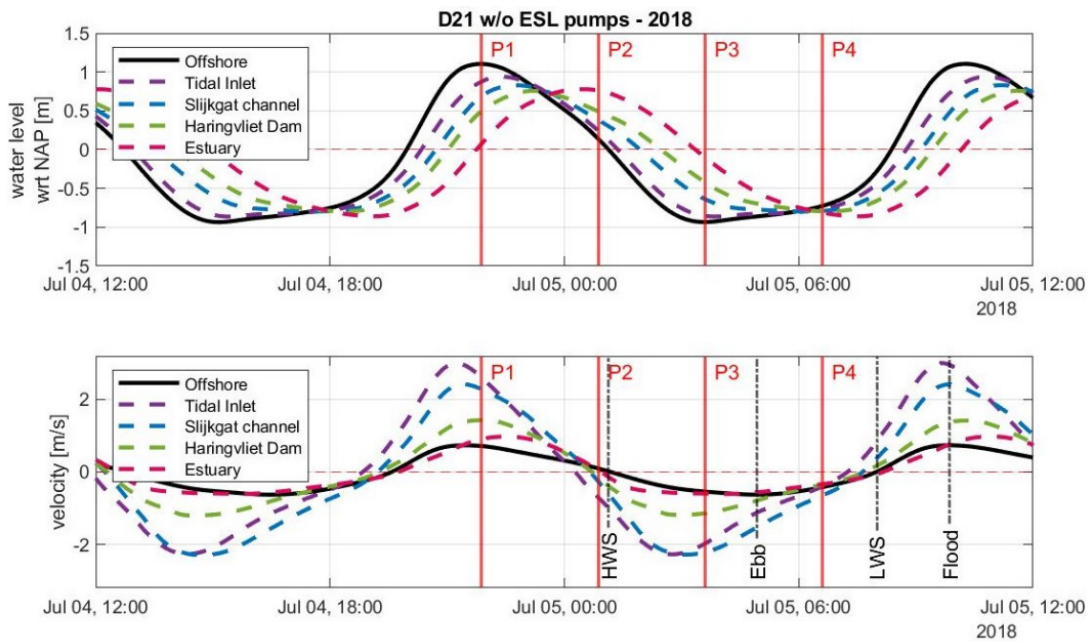

Figure C.1: Water level and flow velocity signals at key locations (Zaldivar Piña, 2020).

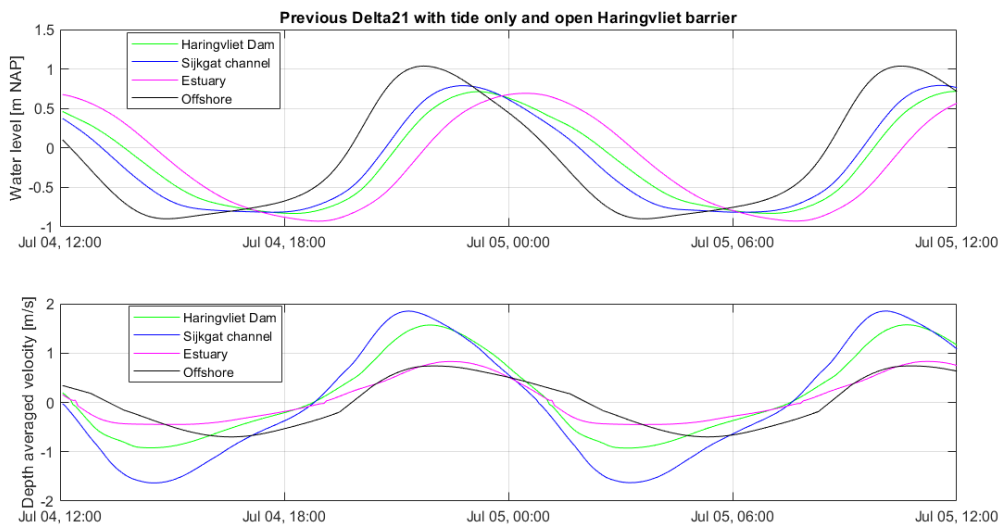

Figure C.2: Water level and flow velocity signals at key locations

The second validation step entails the comparison of morphological developments in and around the tidal lake. This is a more quantitative assessment, because of the different Delta21 design and thus different forcings that result in difference in sediment transport and deposition. Figure C.3 shows the bed level change, considering the same tidal forcing and a yearly mean river discharge. The erosion and sedimentation patterns differ significantly, but are similar in magnitude. The model by Zaldivar Piña (2020) considered a dredged channel, which enhances the erosion in the channel, with respect to the original Slijkgat that has assumed for the first model run for this research. Mainly the magnitude of the bed level change is of importance in this stage for validation, as the design and assumed bathymetry vary too much and may result in a different tidal environment, for instance with difference in flood or ebb dominance.

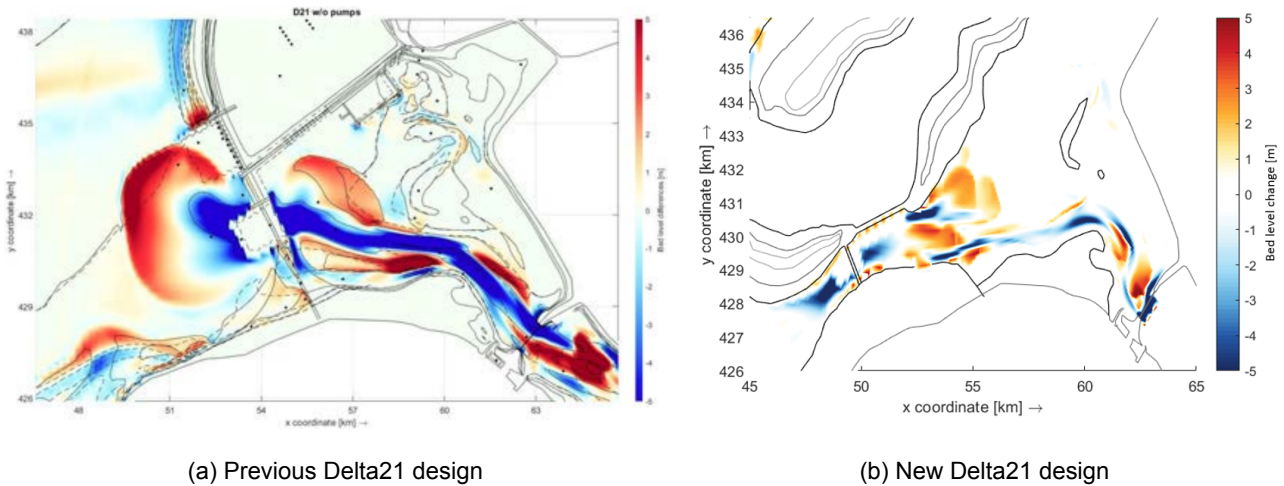

Figure C.3: Erosion and sedimentation patterns of tidal forcing and yearly mean discharge in and around the tidal lake. **(a)** represents results of the run by Zaldivar Piña (2020), with a colour bar range of [-5m 5m]. **(b)** represents the results of this research run with the same hydrodynamic input.

D Discharge Probability of occurrence

The modelling study considers three discharge years separately as input as is discussed in Section 5.4.1. Applying the three kinds of discharge years (maximum, mean and minimum) have been chosen to eventually obtain an indication on the morphological changes, as would have been with a constructed representative year. In order to obtain such an indication, an analysis has been carried out to relate the probabilities of occurrence of the three discharge years with all the available discharge years combined. Figure D.1 shows the results of the cumulative probabilities of occurrences for each discharge year and the distribution of all the available discharge years (13 years) combined. The maximum discharge is set to $7500 \text{ m}^3/\text{s}$, due to the closure regime of Delta21. Notice, that for instance 2018 contains many zero values, which is due to low upstream discharge for a long period of time and the closure regime of the Haringvliet barrier. Furthermore, notice that the mean discharge year 2018 is already a good approximation of the full discharge data, aside from the lowest occurring discharges.

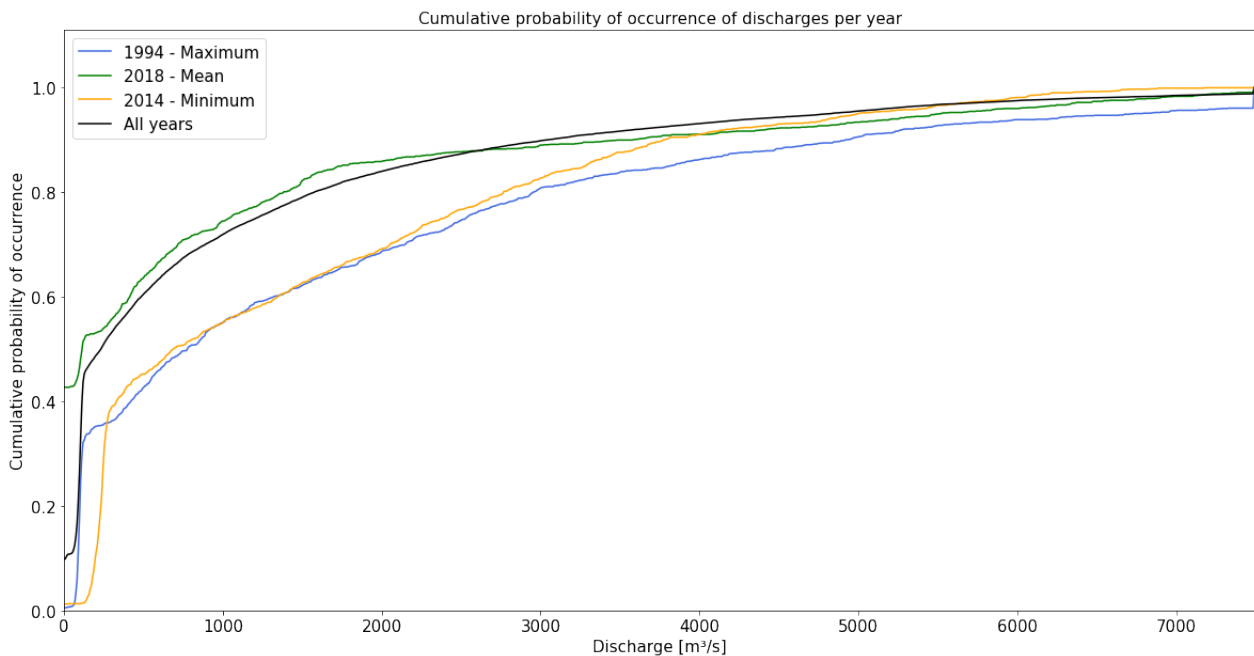

Figure D.1: Cumulative probability of occurrence for the three discharge years and all the available discharge years combined.

Next, the discharge years are used to construct an approximation of the total discharge dataset, assuming the three discharge years. An approximation by weighted factors have been applied on the three years. The analysis has resulted in the weighted distribution in Figure D.2, with the indicated factors per discharge years. The region between $3000 \text{ m}^3/\text{s}$ and $5000 \text{ m}^3/\text{s}$ has the largest deviation with respect to the full dataset. This has to do with the fact that the lines of the three years are all under the total line in the original datasets, as can be seen in Figure D.1. Nonetheless, the maximum discharges are well approximated by the weighted dataset.

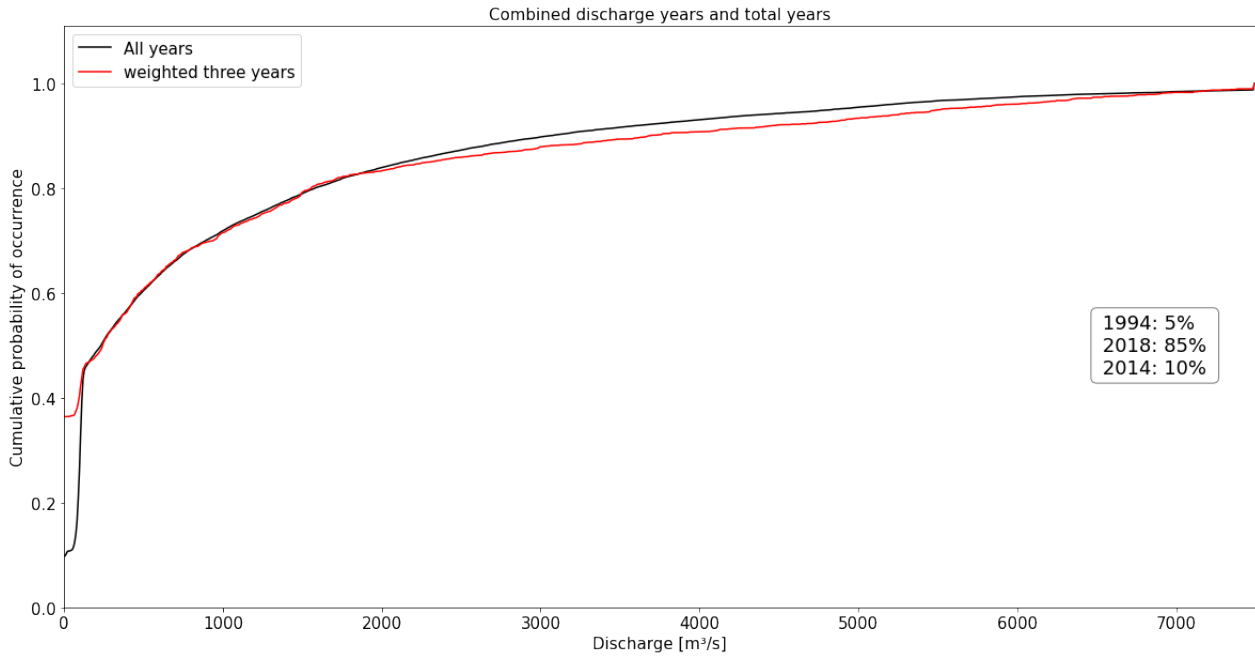

Figure D.2: Cumulative probability of occurrence of the combined years and the weighted data of the three years. The weighted factors are indicated per discharge year.

This analysis allows to indicate the long-term morphological development, assuming the one-year morphological response of the separate years, including the weighted factors. Another element is the dominant contribution of the 2018 discharge year. The high weighted factor and good approximation with the total data are a confirmation of the chosen mean discharge year, both in flow as in morphological response. Still, in the modelling results, the main focus lies on the response of the weighted discharge year for the one-year simulations in order to remain consistent.

E Simulation results

The results of the modelling simulations are presented in an elaborate matter in this section. Both for the flow velocity patterns and the sediment transport for each channel concepts. The relevant findings are listed and explained for each parameter, which are related to the given figures. To support the understanding of the explanations, Figure E.1 is provided where the channel concepts are divided into segments, which are used to indicate a finding in a detailed area.

E.1 Flow patterns

The relevant findings from the results are listed for each concepts and the relation between the concepts are discussed as well. The listed findings are related to the presented flow patterns in Figure E.2.

Initial bathymetry

- Inflow and outflow of the tidal lake flows significantly in and from northern direction. So for instance, the flood flow is not fully guided through the channel, only a part of it. This results in significant velocities at the upper boundary of Segment D in perpendicular direction.
- Within Segments A and B the velocities are high with respect to the surroundings, with the most significant in the bend. This has to do with the deeper parts of the channel where mainly the discharge flows through. In these segments the flow is guided well through the channel and hardly any cross flow does occur under mean discharge conditions.
- Between Segments B and C, the flow decelerates and even changes direction to a cross-channel direction. For flood flow, these cross-channel directions are towards the channel and the other way around for ebb flow. Also at flow reversal, these cross vectors can be observed. This local velocity gradient is due to the locally deeper parts of the surrounding bed, which allows more storage of flow from the channel. Also within and southern of the channel there are velocity deflections and local velocity gradients in several directions. This too leads to increase of turbulence in and around the channel. The flow accelerates again to significant flow velocities around the storm surge barrier in Segment D, where a narrowing of the channel cross-section occurs.
- Another feature outside the channel is the horizontally orbiting velocities at flow reversal at the Hinderplaat, above Segment B. These eddy velocities at the Hinderplaat causes transport to the surroundings. For instance at flood flow, there is a flow over the Hinderplaat, directed to the deeper parts of the channel bend.

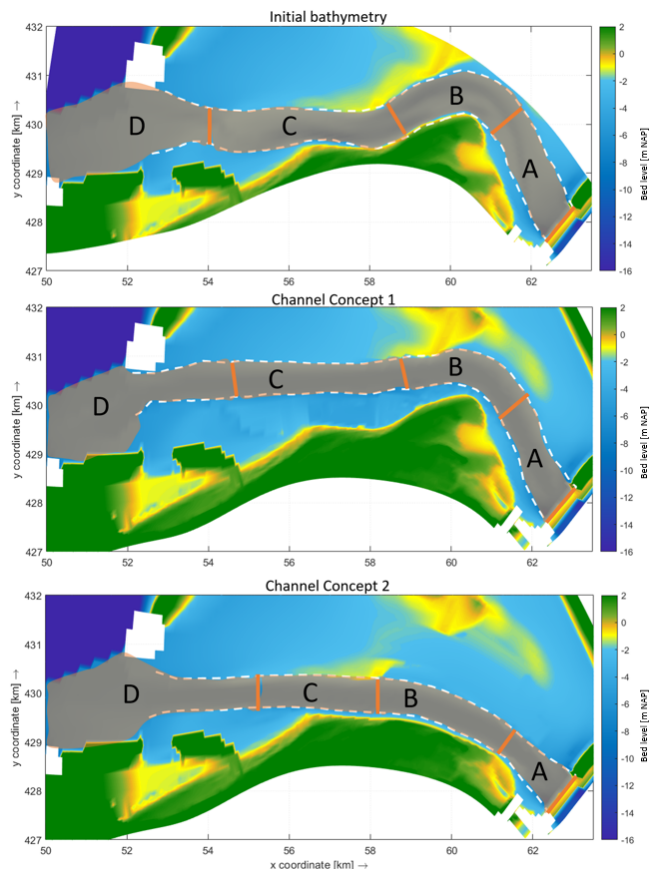

Figure E.1: Defined channel segments per concept, including the initial bathymetry with the Slijkgat.

Channel Concept 1

- Similar patterns hold for this concept as for the initial one. Segments A and B too contain high velocities in (the center of) the channel and lower outside the channel. At the transition of Segments B to C, there is again a more deepened surrounding area where the flow decelerates and deviates in cross-channel direction. These cross-channel directed are however significant to the initial bathymetry and stretch over a longer distance. The velocity gradients southern of Segment C stretch over a larger area as well, this has to do with the changed orientation of the channel concepts.
- Part of the Hinderplaat has been dredged for this concept and the surrounding bed has not been shallowed enough in the design, which allows a larger area of local velocity gradients. This allows for a larger area of velocity gradients and flow deflection in Segment C, which is disadvantageous for remaining the channel orientation and where local deceleration occurs.
- Around the transition from Segment C to D, there are shallow areas at the boundaries of the channel, which results in acceleration of the flow in the channel locally. However, still the north-ern directed tidal in and outflow allows for perpendicular flow to the channel.

Channel Concept 2

- For this channel too, the tidal flow is similar in and around the channel as for the other concepts.
- The velocities in Segments A and B are high in the channel for the same reason as for the other concepts. However, by mitigation of the curvature of the bend, the flow is less exposed to curved and helical flow within the channel. This may still result in high velocity over a long stretch of the channel, but it does follow the orientation in a gradual matter, which can be observed from the figures as well.
- The high flow velocities gradually follow the entire orientation of the channel, unlike the other two concepts. There are still the velocity gradients and cross-channel directed vectors in Segments B and C, but these are less significant than the previous concepts and with respect to the local high velocities in the channel, are less effecting the flow.
- Unlike Channel Concept 1, Channel Concept 2 has a part of the Hinderplaat remained due to the orientation, which functions as a guidance of the flow through the channel. The velocity gradients therefore occur more downstream at the transition between Segments C and D and over a shorter stretch.

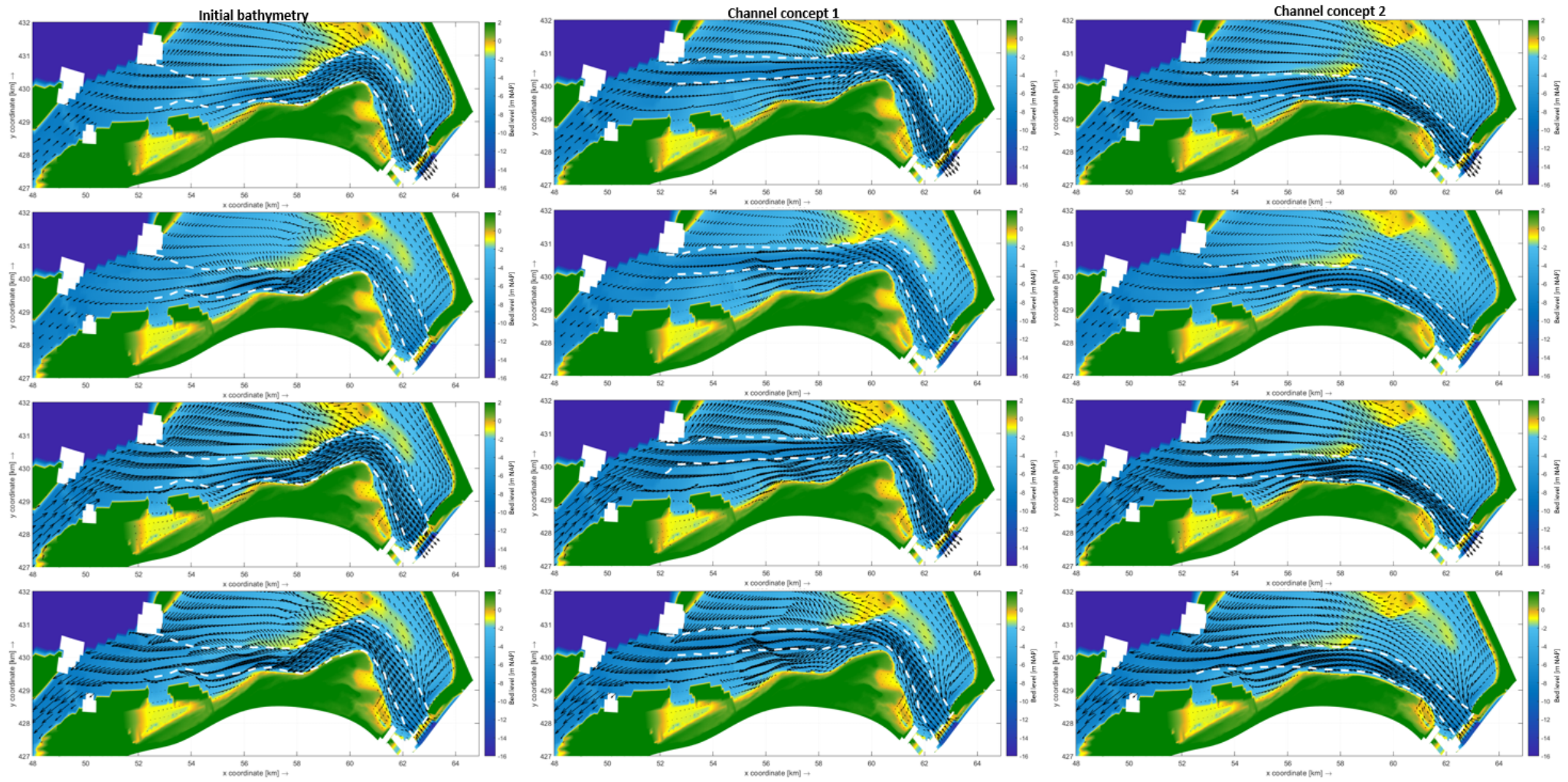

Figure E.2: Flow velocity patterns for each channel concepts at the same four moments in time of the simulation.

E.2 Longitudinal and cross velocities

The quantitative assessment results of the extreme velocities under normal conditions are presented in this section. As mentioned in Section 6.1.3, the quantitative assessment is based on the flow velocities, which include a river discharge that corresponds to a 0.1 exceedence probability. For each channel concept 20 points are selected along the channel, for which the longitudinal and cross velocity components are determined. These are determined for each hour during a tidal cycle with the desired river discharge. The two component velocities per hour are presented in Figure E.3 and Figure E.4.

Additionally, the velocity gradients have been determined between each point along the channels. This to indicate local spatial changes in flow velocity, which may cause hindrance for navigability in the channel. The velocity gradients are in m/s/m, over a ship length of 135 m. So, a gradient over 135 m along the channel. The results are presented in Figure E.5 and Figure E.6, similarly to the velocity components.

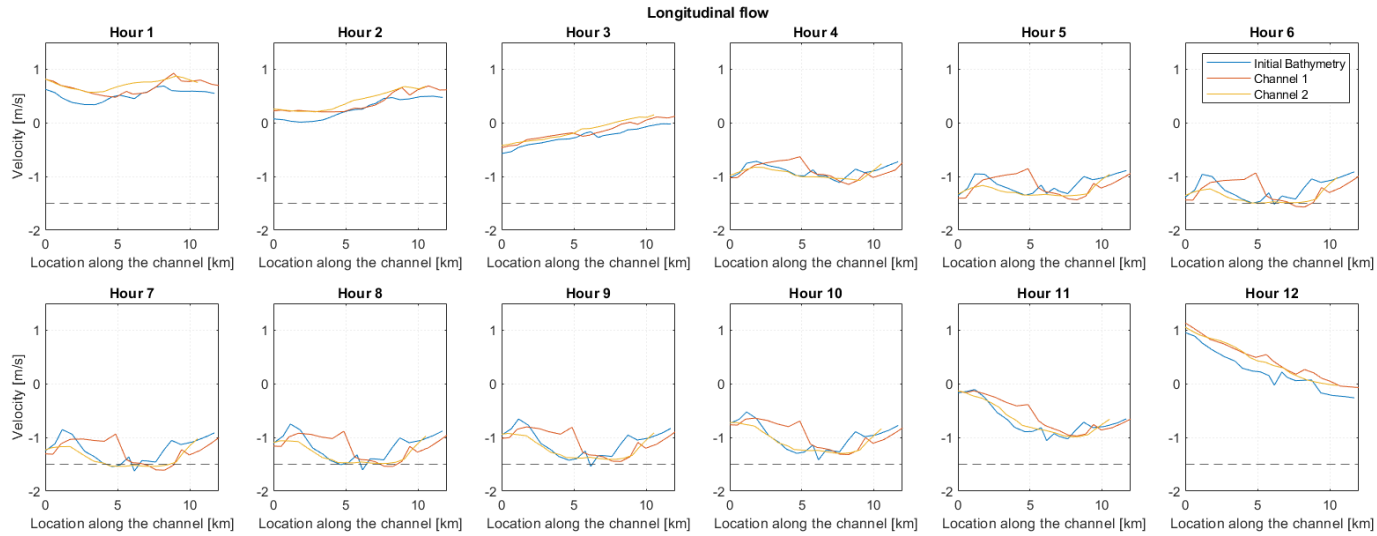

Figure E.3: Longitudinal current velocities along the channels per hour over a tidal cycle.

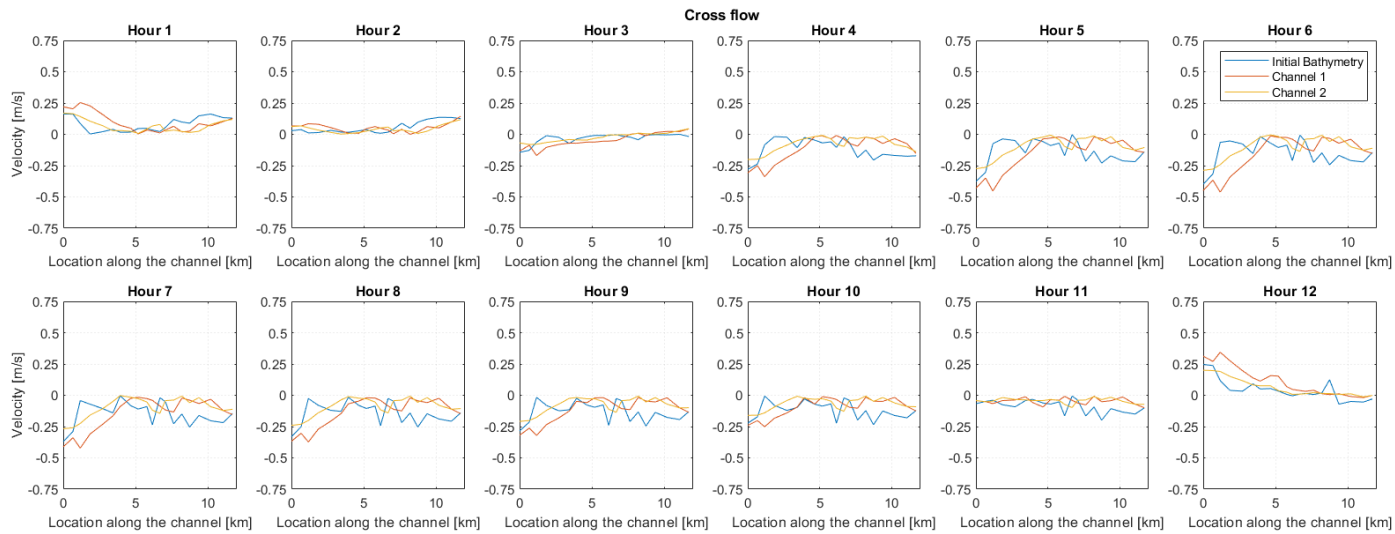

Figure E.4: Cross current velocities along the channels per hour over a tidal cycle.

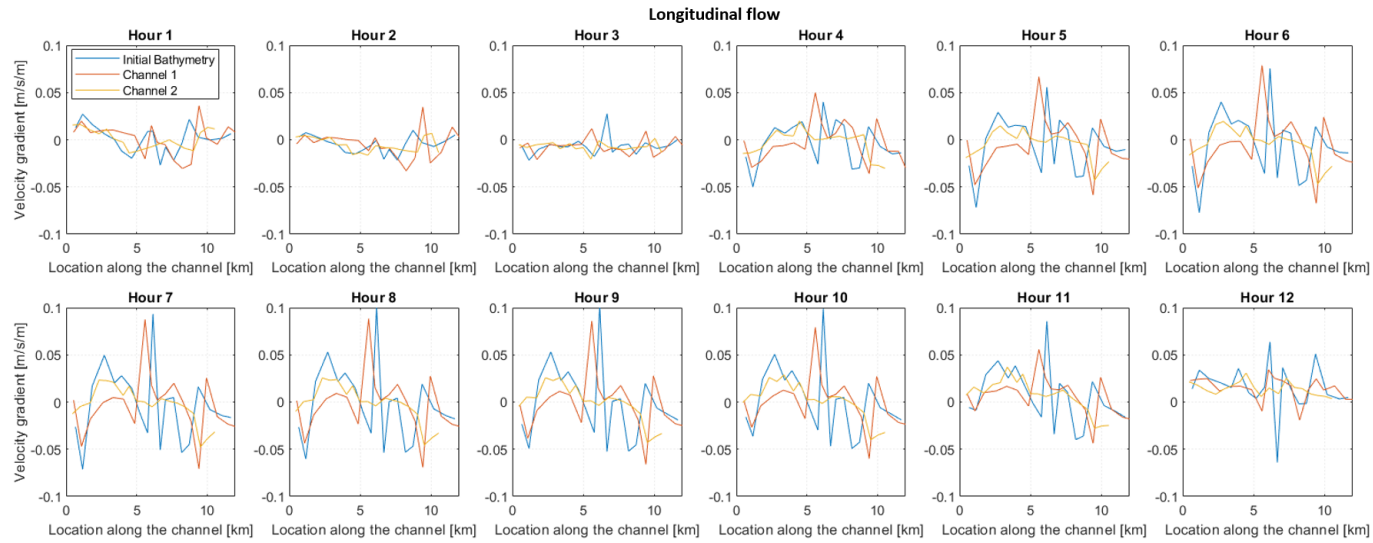

Figure E.5: Longitudinal current velocity gradients along the channels per hour over a tidal cycle.

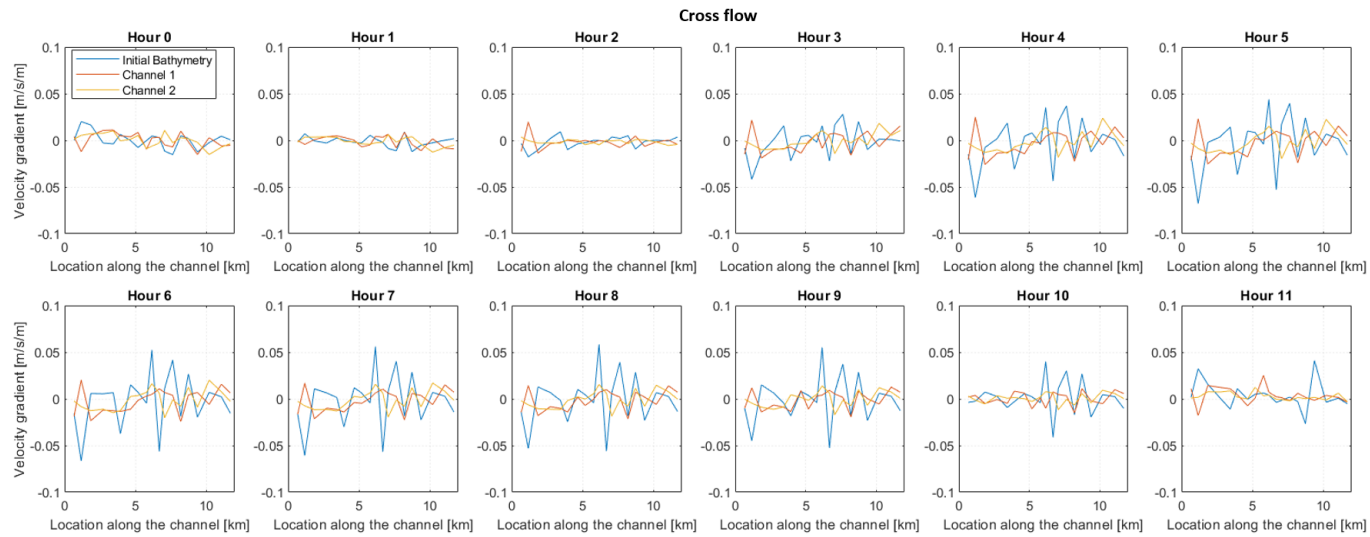

Figure E.6: Cross current velocity gradients along the channels per hour over a tidal cycle.

E.3 Sediment transport patterns

The sediment transport results are presented similar as for the flow patterns. The relevant results are explained for each concept and compared with one another. Again, the segment layout of Figure E.1 is used to assign certain areas.

Initial bathymetry

- The erosion and sedimentation form alongside each other throughout the channel in cross direction and become larger over time. This is due to the inequality of the bed of the current Slijkgat, which is enhanced by the effect of the curving bend in Segments B and C. The same phenomenon occurs at the Haringvliet sluices. It can not be observed in the flow velocity results that there is a difference in flow over the sluices. Erosion over the width of the barrier would be expected. It is probably due to sediment transported by the flood flow.
- The innerbend erodes due to high flow velocities. The outerbend accretes with sediment due to deceleration over the bend and inflow of sediment of the Hinderplaat. The same holds partly for Segment C, where erosion and sedimentation are significant within a cross-section. This has mainly to do with the local velocity gradients in Segment C and the inflow of sediment from the Hinderplaat. It has also to do with the effect of the in and outflow of the tide, which makes new flood and ebb channels.
- An increase of sedimentation in the channel is observed at the transition of Segments C and D. The sedimentation is due to the deceleration of the flow from the storm surge barrier narrowing and the sediment transport from the easterly outflow of the channel by ebb flow together with discharge. As mentioned already, it is supported by sediment inflow from the Hinderplaat and the tidal forcing from the north.
- In terms of erosion, in Segment C there are still high velocities that result in migrating erosion in westerly direction as can be seen. The sedimentation alongside the erosion over the cross-section results in a narrowing and meandering of the channel, which enhances erosion to develop. However, it does not follow the orientation of the initial Slijkgat and is 'blocked' by the large sedimentation at the transition of Segments C and D.
- The tidal inflow and outflow around the inlet does result in formation of erosion in Segment D and in northern direction, as was expected from the flow patterns as well that support this source of transport. This flow direction is in line with in and outflow at the inlet, so the developing erosion is expected. This phenomena occurs for each concept, where the least erosion occurs for the initial bathymetry.
- Over time the orientation and geometry of the channel does change and can not fulfil the requirements. This is the current channel, which does not necessarily fulfil the requirements beforehand. Still, dredging is necessary over time to fulfil the requirements even though they are set for the new concepts.

Channel Concept 1

- The expected erosion in the bend by the high velocities develops similar as for the initial bathymetry, but increases more significant over time. This is probably due to the straight orientation of the concepts easterly of the bend. The flow experiences less curvature with respect to the initial bathymetry, where accelerations are enhanced.
- The accelerating flow in the bend results in a relatively large deceleration in the dynamic Segment C. The dynamic area has been explained in the previous section, where locally significant velocity gradients occur as well as deflection of the flow. Together with the high velocities in Segments B and D, will result in sedimentation in Segment C. Especially, in the first three months

this phenomena is observed. Less sediment from the Hinderplaat flows into the channel due to the dredging of part of it for the concept. Still, there is inflow due to the tide into the bend and Segment C.

- Over time the sedimentation migrates to the south and west of the channel. Also additional erosion develops southern of Segment C. So, the initial geometry of the channel holds partly in the end. Due to the (change of) tidal flow and deeper parts for storage, certain tidal channels develop with accompanying shallow (sedimented) parts adjacent to them.
- The amounts and locations of sedimentation results initially to blockage of the navigability in Segment C. Over the entire cross-section the required depth is not fulfilled. Over time a narrow (new) channel forms with sedimentation alongside it, which results in a too narrow channel. So, at different moments in time, dredging is necessary for this concept in order to fulfil the requirements.

Channel Concept 2

- As mentioned for the flow, this concepts is less influenced by the curvature of flow, which results in less deflection and velocity gradients in Segments A to C. This results in the observed erosion due to the high velocities that remain along the channel in both directions. The significant erosion starts at the transition of Segments A and B and develops over time over C as well. The erosion does support the increase of velocity and sediment transport, which gives the expected result in the channel. Incoming sediment from the Hinderplaat and other adjacent shallow areas are transported mainly by outflow to Segment D.
- Similar to Channel Concept 1, but more downstream, local velocity gradients (deceleration of the flow) result in sedimentation in Segment D, east from the inlet. Again the erosion is in line with the in and outflow at the inlet. The sedimentation is very concentrated with respect to the other concepts. It does not block the channel as much as for Channel Concept 1, and a new narrow channel forms earlier in time. Still, dredging measures should be considered for this amount of sedimentation to fulfil the requirements. However, due to the concentrated location of sediment and the well contained orientation of the channel, the dredging should be managed better than the other concepts.

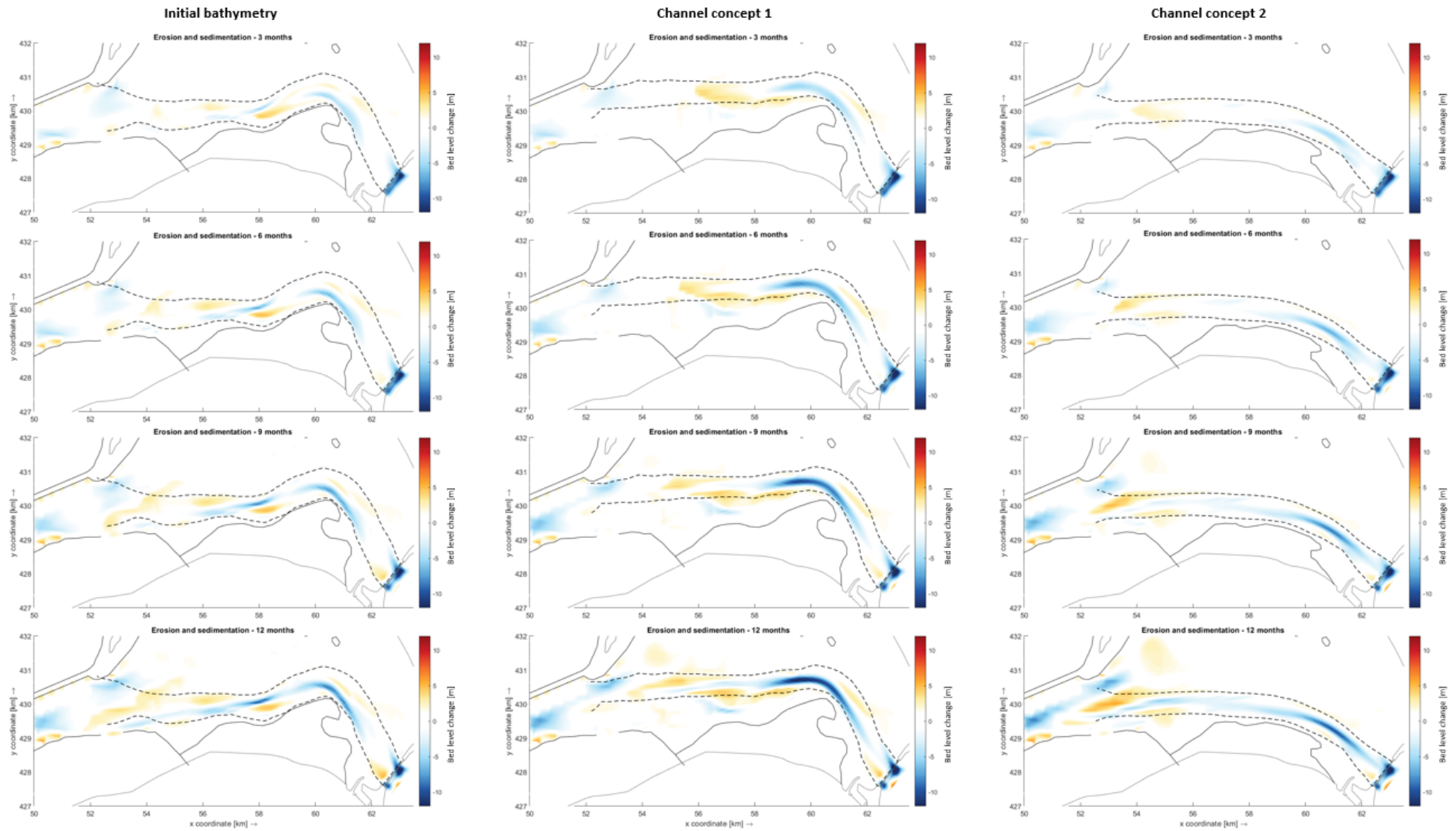

Figure E.7: Erosion and sedimentation patterns for each channel concept with a timestep of 3 months.

F Evaluation components expansion

The evaluation for this research, which determines the channel concept selection is performed with a multi criteria analysis. This entails a scoring mechanism for each criterion per concept. The scoring is based on a range of 1 to 5, with 1 the worst score and 5 the best score.

F.1 Evaluation scoring characteristics

In order to prevent arbitrary and subjective scoring, characteristic have been set up, which support the reasoning for giving a specific score for a criterion. The characteristics are listed below for each criterion and are provided with the corresponding score. Note that criteria 1.3 is split into two parts, a longitudinal and cross part. It depends on the flow and the corresponding direction and magnitude what the vessel is subjected to. So, the one directed flow may cause a safety threat and the other not. In order to assess this phenomena thoroughly the two directions are considered separately and the score is multiplied by 0.5. In total, there is a even score for this criteria with respect to the other criteria.

Navigability

1.1 Navigability after extreme event with open spillway and closed storm surge barrier.

- (5) The channel remains navigable and no maintenance is required
- (4) The two lane channel remains navigable but maintenance is required on short notice
- (3) One lane of the channel remains navigable and maintenance is required
- (2) The channel is not navigable, but is restored with little maintenance
- (1) The channel is not navigable and extensive maintenance is necessary to restore navigability

1.2 Undesired location and orientation change of the channel over one year under normal conditions.

- (5) Orientation and location of the channel remains in the same framework as the initial situation
- (4) Orientation and location of the channel has changed insignificant and requires small reposition of the channel framework
- (3) Orientation and location of the channel has shifted significantly to adjacent sand banks, but remains navigable
- (2) Orientation and location of the channel has shifted significantly to adjacent sand banks and causes hindrance in terms of manoeuvrability and delay
- (1) Orientation requires maintenance to secure navigability and location has fully shifted to an adjacent sandbank

1.3 Navigability hindrance by flow under normal conditions.

a). Longitudinal flow ($\times 0.5$)

- (5) Longitudinal currents never exceeds the required magnitudes and velocity gradients are negligible
- (4) The required magnitudes are hardly exceeded and velocity gradients are minimal
- (3) The required magnitudes are hardly exceeded and significant velocity gradients occur, but do not lead to dangerous situations

- (2) The required magnitudes are exceeded more often and significant velocity gradients occur, which may lead to dangerous situations
- (1) The required magnitude is exceeded frequently, together with large velocity gradients, which too often leads to dangerous situations

b). Cross current flow ($\times 0.5$)

- (5) Cross currents never exceeds the required magnitudes and velocity gradients are negligible
- (4) The required magnitudes are hardly exceeded and velocity gradients are minimal
- (3) The required magnitudes are hardly exceeded and significant velocity gradients occur, but do not lead to dangerous situations
- (2) The required magnitudes are exceeded more often and significant velocity gradients occur, which may lead to dangerous situations
- (1) The required magnitude is exceeded frequently, together with large velocity gradients, which too often leads to dangerous situations

Maintainability

2.1 Required sedimentation volume to be dredged per year (Mm^3), considering normal conditions

- (5) Required dredged volume is less than 2.5 Mm^3 per year
- (4) Required dredged volume is between 2.5 and 7.5 Mm^3 per year
- (3) Required dredged volume is between 7.5 and 10 Mm^3 per year
- (2) Required dredged volume is between 10 and 12.5 Mm^3 per year
- (1) Required dredged volume is more than 12.5 Mm^3 per year

2.2 Maintenance dredging repetition, which requires (additional) operational costs and availability of the hopper

- (5) Dredging is not necessary after one year
- (4) Dredging is necessary after one year
- (3) Dredging is necessary after half a year
- (2) Dredging is necessary after 3 months
- (1) Dredging is necessary within 1 month

2.2 Required maintenance dredging volumes in the second year, with respect to the dredging volumes of the first year

- (5) Yearly maintenance dredging volume is smaller than 10% of the dredging volume after the first year
- (4) Yearly maintenance dredging volume is smaller than the dredging volume after the first year (within 10% and 90%)
- (3) Yearly maintenance dredging volume is somewhat similar as after one year (around 10% difference)
- (2) Yearly maintenance dredging volume is around 1.5 times the volume after the first year
- (1) Yearly maintenance dredging volume is around twice the dredging volume after the first year

Nature preservation

3.1 Preservation of current sand banks and intertidal areas.

- (5) The current sand banks are hardly influenced by construction of the channel and further morphological changes over time
- (4) The current sand banks are hardly influenced by construction, but show clear changes over time by morphological changes
- (3) Small areas of current sandbanks have disappeared for construction and there are visible extended changes over time
- (2) Large areas of current sandbanks have disappeared for construction, but parts have been restored or extended elsewhere over time
- (1) Large areas of current sandbanks have disappeared for construction and the disappearance extends further over time

F.2 Scoring argumentation

The scoring per criterion is performed by following the characteristics per score. The reasoning for a specific score, regarding the modelling results, is listed in Table F.2. The argumentation corresponds to the score that is indicated by the colour of the cell. The colour of a specific score is given in Table F.1.

Table F.1: Scoring colours assigned to specific score

Scores
5
4
3
2
1

Table F.2: Argumentation for the performed scoring of the criteria per concept. The cell colours correspond with the assigned colours of the score, given in Table F.1

Criterion	Initial bathymetry	Channel Concept 1	Channel Concept 2
1.1 Navigability after extreme event with open spillway and closed storm surge barrier.	Sedimentation on several locations throughout the channel where a two lane channel with the required depth does not hold.	Sedimentation halfway the channel and long stretch of sedimentation along the centre of the bend. One-way channel just remains.	Sedimentation throughout the channel is located at the channel sides and very little on deeper parts in the channel. The two way channel just remains.
1.2 Undesired location and orientation change of the channel over time.	Erosion and sedimentation develops throughout the channel, which results in large changes outside the original channel framework and a meandering orientation inside.	Some erosion occurs outside the channel, together with sedimentation elsewhere. The orientation and location of the channel does not change significantly and does not pose manoeuvrability problems.	Erosion and sedimentation in the western part result in deflection of the orientation to the south, but not outside the framework.
1.3a Navigability hindrance by flow. Longitudinal flow	The threshold velocity is exceeded a few times for 10% exceedance probability and highest maximum occur for this concepts. Velocity gradients are significant and volatile along the channel.	The threshold is exceeded a few times for 10% exceedance probability and velocity gradients are significant and volatile.	The threshold velocity is exceeded a few times and a gradual velocity distribution holds along the channel, unlike the other concepts. The velocity gradients are hardly significant and gradual.
1.3b Navigability hindrance by flow. Cross current flow	The threshold velocity is not exceeded for a 10% exceedance probability, but volatile along the channel. Velocity gradients are significant and volatile along the channel. Especially for cross flow this may cause dangerous situations.	The threshold is not exceeded for 10% exceedance probability and velocity gradients are quite significant and volatile, but do not cause dangerous situations, with respect to the initial concept.	The threshold is not exceeded for 10% exceedance probability and velocity gradients are insignificant and gradual along the channel.
2.1 Required sedimentation volume to be dredged per year (Mm^3), considering normal conditions	Required dredged volume after one year rounds up to $12.5 Mm^3$. So, just below the characteristic threshold.	Required dredged volume after one year equals $12.0 Mm^3$.	Required dredged volume after one year equals $9.6 Mm^3$.
2.2 Maintenance dredging repetition, which requires (additional) operational costs and availability of the hopper	Considering the results after 3 months, it is observed that the sedimentation, western of the bend, in the channel requires dredging. Results after one month did not require dredging.	After three months a sedimentation blockage occurs halfway the channel. Additional results after one month also indicate sedimentation on this location and require dredging.	Sedimentation occurs after three months, but navigability is still possible. The sedimentation after 6 months is more significant and requires dredging.
2.3 Required maintenance dredging volumes in the second year, with respect to the dredging volumes of the first year	The second year dredging volume is 25% smaller than that of the year before, which falls in the range of 10%-90% decrease.	The second year dredging volume is 37% smaller than that of the year before, which falls in the range of 10%-90% decrease.	The second year dredging volume is 5% smaller than that of the year before, which is assumed similarly, but still smaller.
3.1 Preservation of current sand banks and intertidal areas.	The sand banks are not effected by construction due to being the current channel. However, the meandering and change of orientation does erode adjacent sand banks over time	A part of the hinderplaat has disappeared for construction and over time the erosion of sand banks is minimal.	The construction led to disappearance of more than half of the Kwade Hoek. The erosion of adjacent sand banks does not continue to happen.