

COMPLEX PROJECTS GRADUATION STUDIO
BERLIN OPEN DEPOT

Public Art Depot for Germany
Laura Kemp - TU Delft
01/11/2023

1. INTRODUCTION

2. RESEARCH

3. DESIGN BRIEF

4. DESIGN

ambitions

solutions

implementation

5. CONCLUSION

1. INTRODUCTION

2. RESEARCH

3. DESIGN BRIEF

4. DESIGN

ambitions

solutions

implementation

5. CONCLUSION

BERLIN ART SCENE

Leonid Brezhnev and Erich Honecker in a socialist fraternal kiss.

Depicted on the Berlin Wall as public canvas for art.



'My God, Help Me to Survive This Deadly Love', graffiti art by Dmitri Vrubel, 1990.

MUSEUMSCAPE **CURRENT TRENDS**

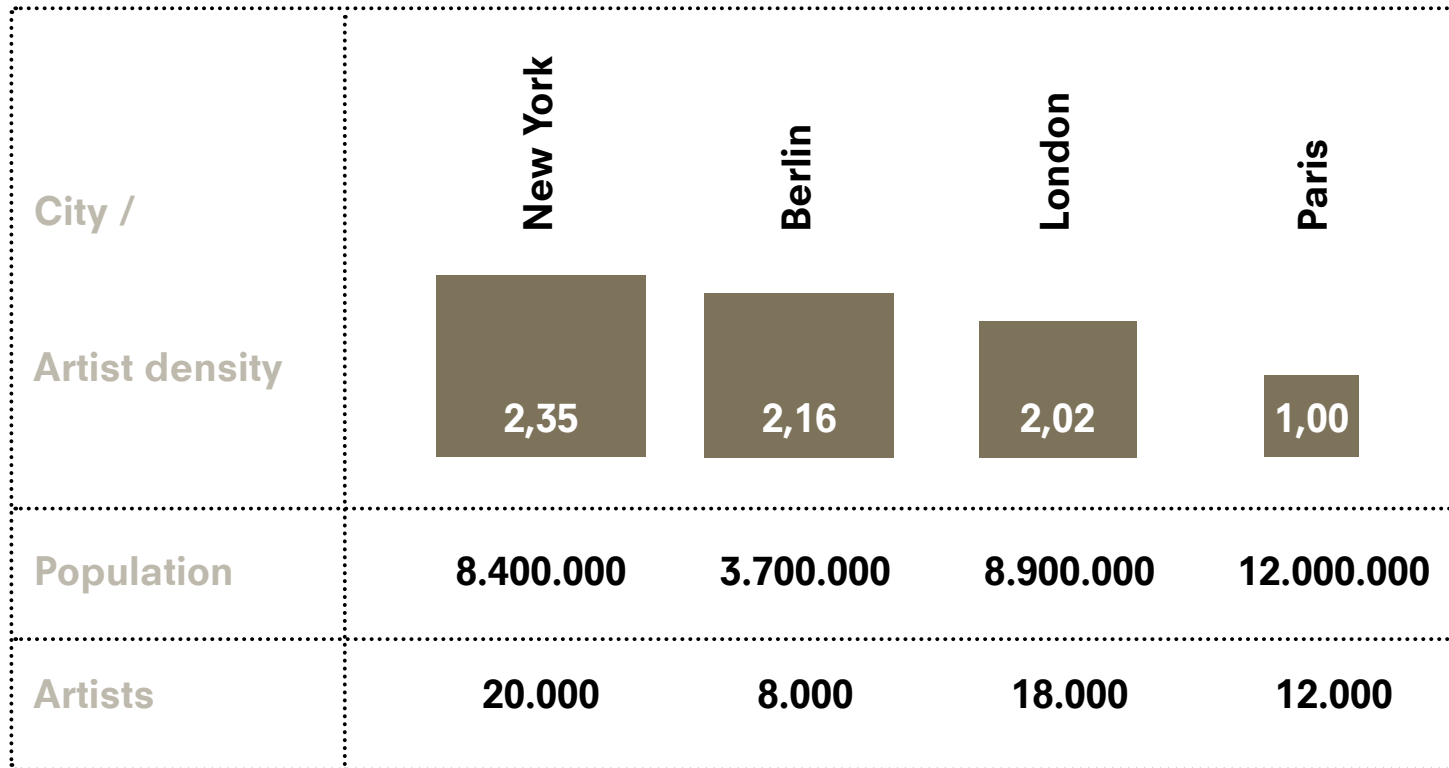

Artist density in Berlin is higher than in London and Paris

MUSEUMSCAPE **CURRENT TRENDS**

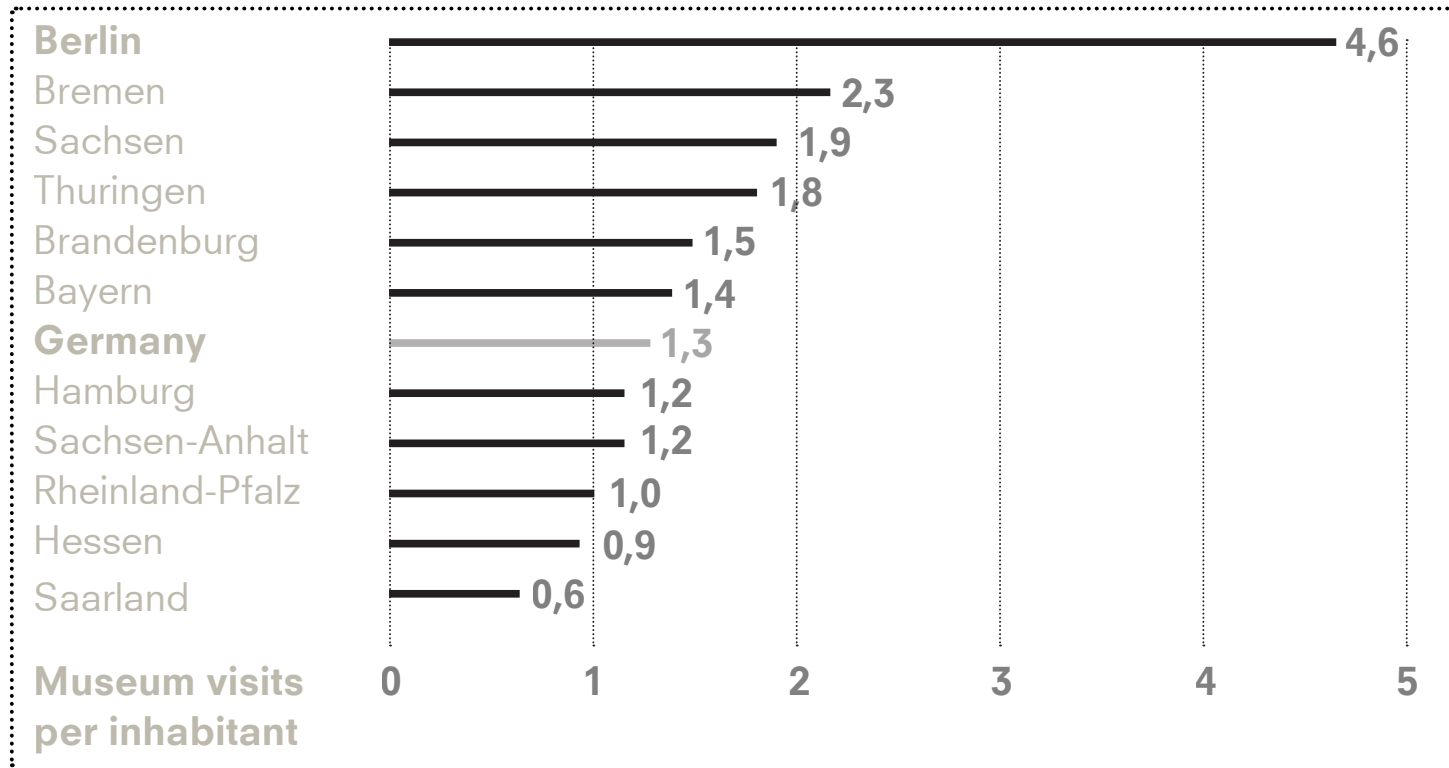

**Museum visits are highest in Berlin
[per inhabitant by federal state]**

1. INTRODUCTION

2. RESEARCH

3. DESIGN BRIEF

4. DESIGN

ambitions

solutions

implementation

5. CONCLUSION

Research

HISTORY OF THE MUSEUM

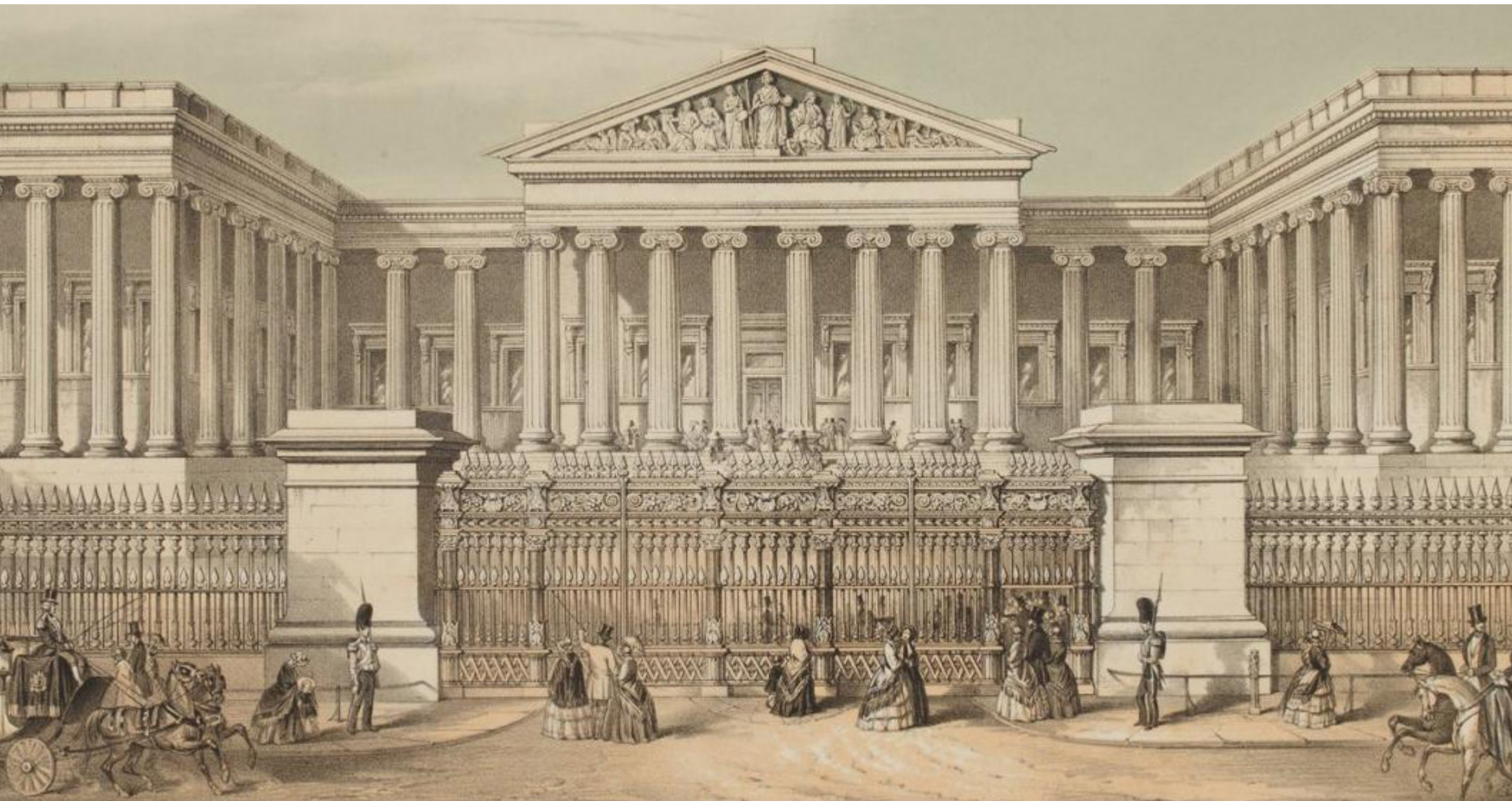

HISTORY OF THE MUSEUM



530 BC



1599

Ennigaldi-Nanna's museum (530 BC), Wunderkammer (1599). UNESCO Heritage, 2023.

Research

HISTORY OF THE MUSEUM



530 BC

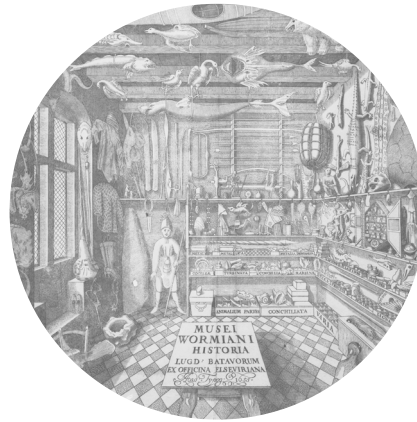

1599



2025

Ennigaldi-Nanna's museum (530 BC), Wunderkammer (1599), British museum virtual reality exhibition (2023). UNESCO Heritage, 2023.

Research

MUSEUM TYPES

Aeronautical museums

Archeological museums

Art museums

Automobile museums

Chemical museums

Ethnological museums

Historical museums

Interactive science museums

Literary museums

Maritime museums

Music museums

Natural history museums

Virtual museums

Research

DISPLAY



The artist of the portrait is the Italian painter Rosalba Carriera (1675-1750). She was a Venetian artist who specialized in pastel portraits. Her work is characterized by its softness and delicate touch. She was one of the most successful portraitists of the 18th century.

ROBALBA CARRIERA
Venetian, 1675-1750

Her Name: 1742

ROBALBA CARRIERA
Venetian, 1675-1750

Her Name: 1742

JOHANN CHRISTOPH WÖHLER
Bavarian, 1733-1807

Her Name: 1742

ROBALBA CARRIERA
Venetian, 1675-1750

Her Name: 1742

ROBALBA CARRIERA
Venetian, 1675-1750

Her Name: 1742

ROBALBA CARRIERA
Venetian, 1675-1750

Her Name: 1742

Research
STORAGE

95%

OF THE COLLECTION
IS LOCKED AWAY

5%

OF THE ENTIRE COLLECTION
IS ANY GIVEN TIME ON DISPLAY

Metropolitan Museum of Art (2023)

complex  projects

Research
NEW TYPOLOGY **OPEN-DEPOT**

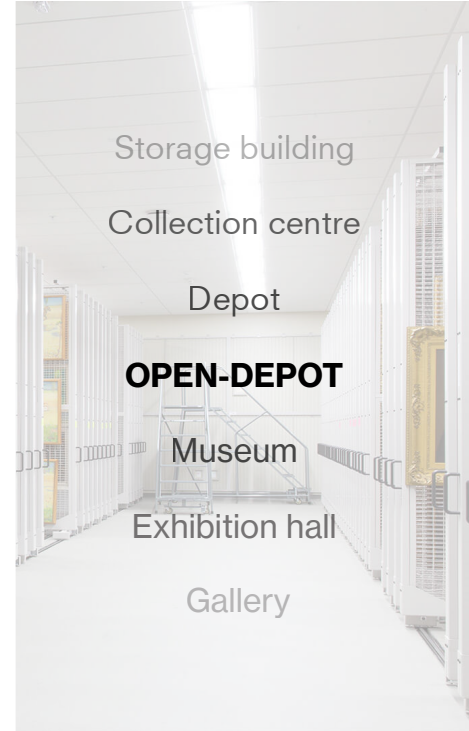
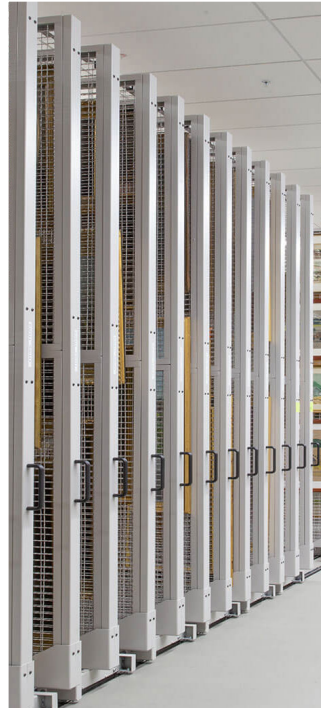
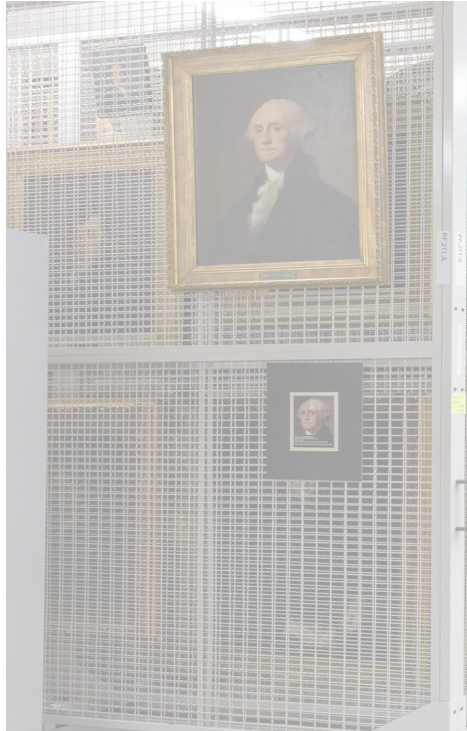

Research
OPEN-DEPOT

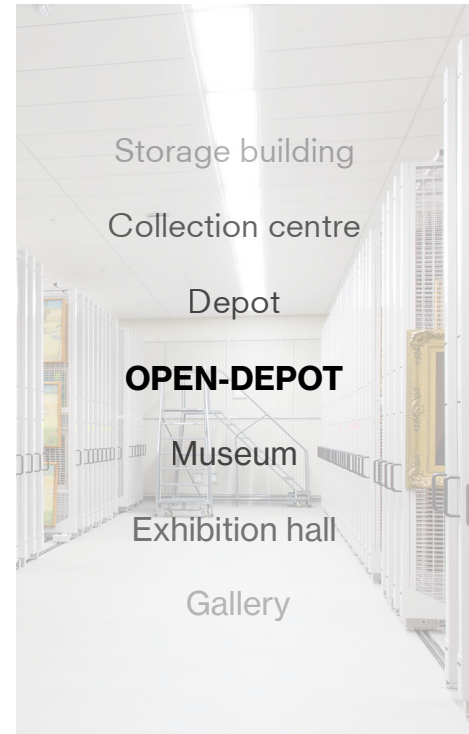

Research RELATION **BODY - OBJECT**

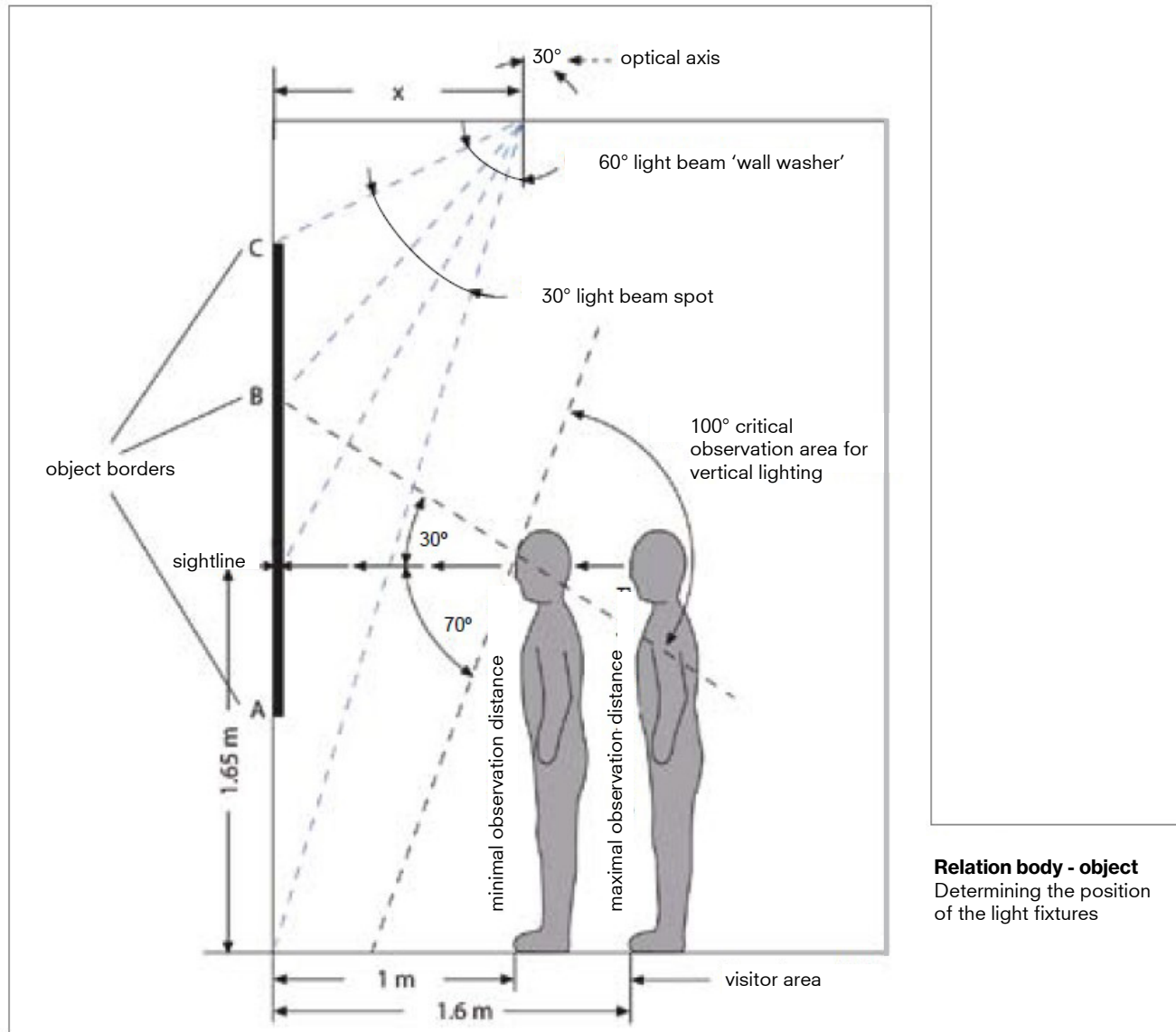

RELATION **BODY - OBJECT**

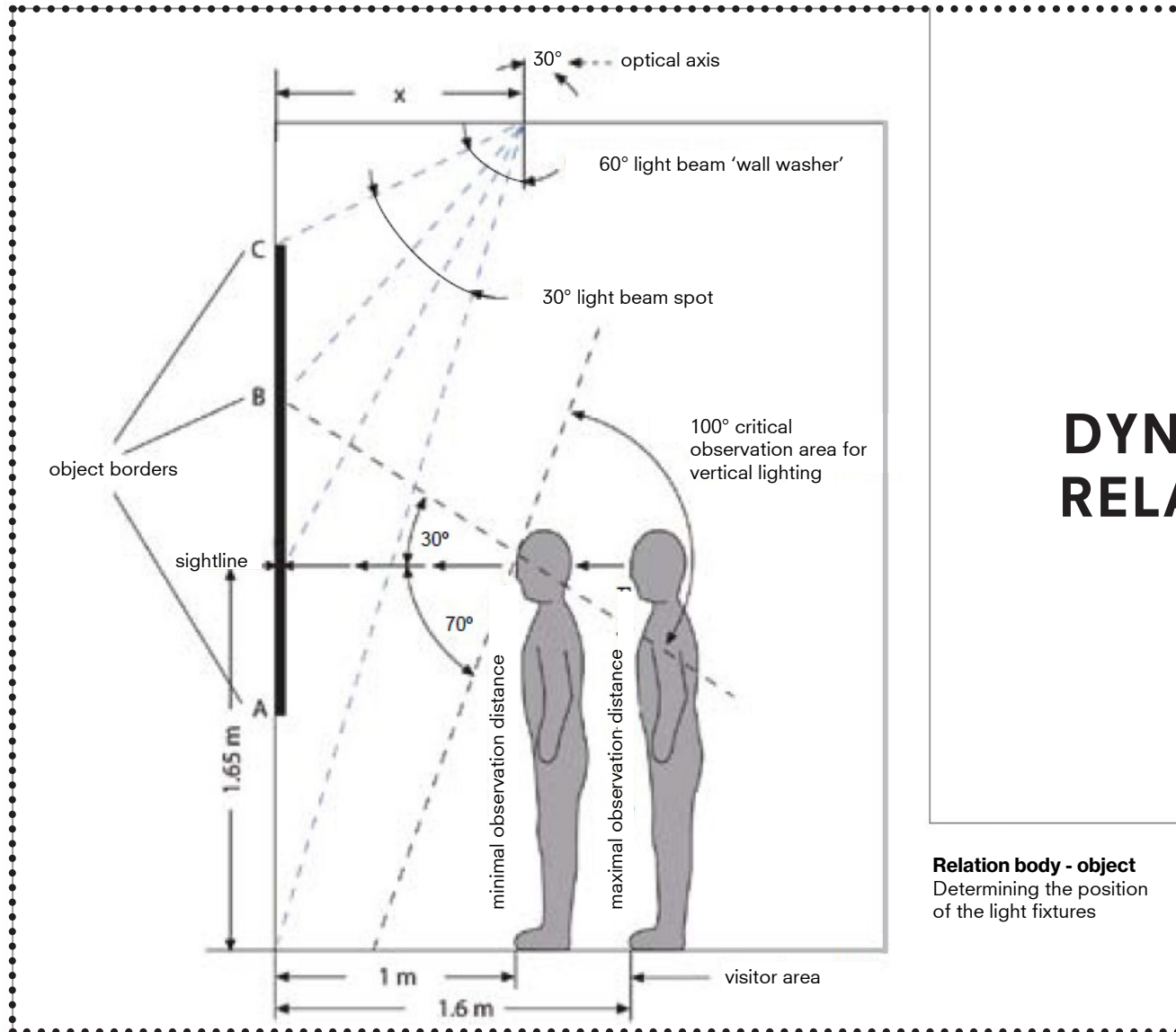

MUSEUMSCAPE UNDER PRESSURE

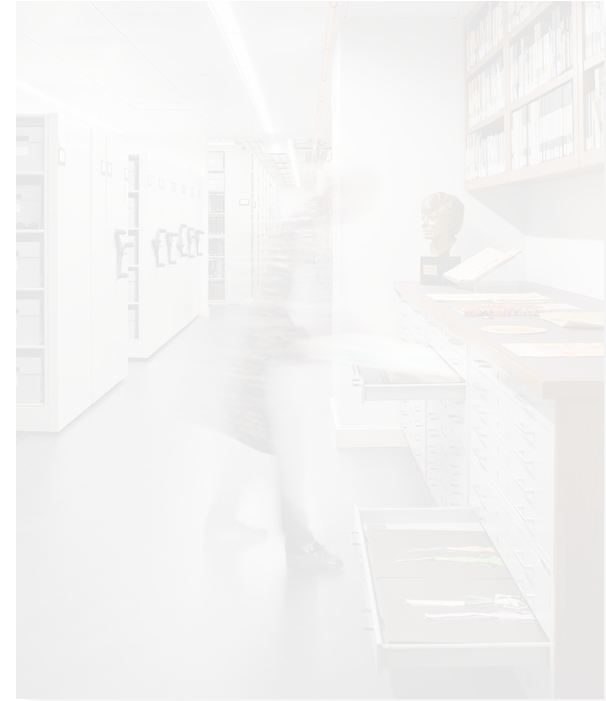

Museumscape Berlin:
insufficient storage facilities
inaccessible for research and public
not meeting sustainability standards

MUSEUMSCAPE UNDER PRESSURE

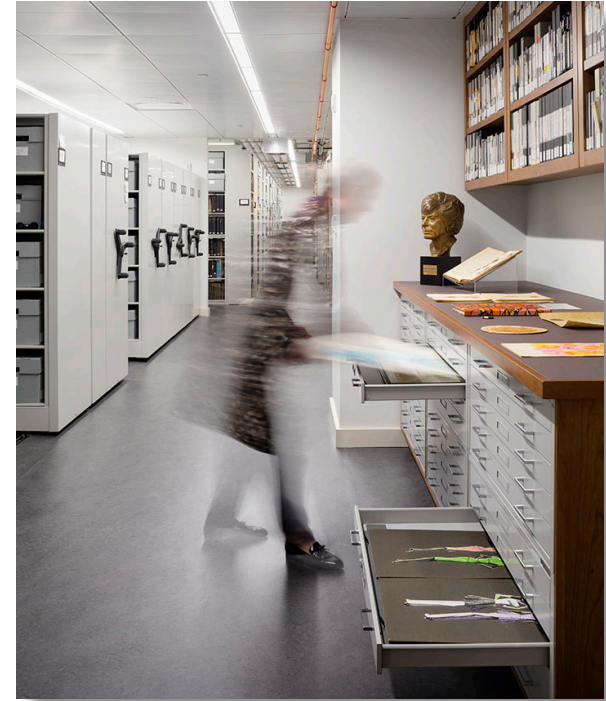

Project ambition:
sufficient storage facilities
accessible for research and public
meeting sustainability standards

GROWING COLLECTIONS

*Number of
objects in
storage*

Storing museum collections: an
unresolved problem
Yani Herreman

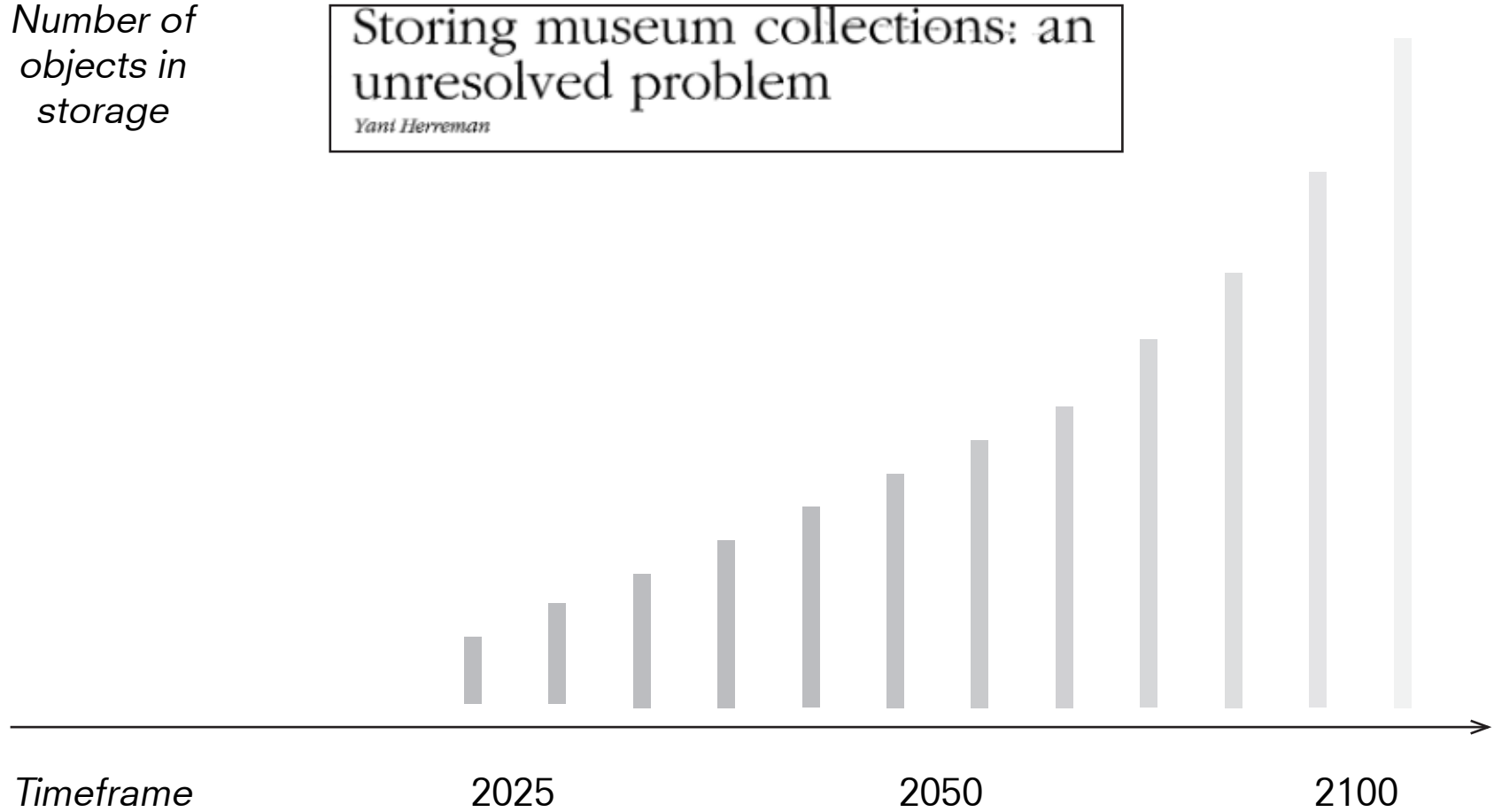

Research

THE COLLECTION **GROWTH**

Growth and change of the collection requires a space that is **adaptable**

Research

CONCLUSION

ALTERNATIVE STORAGE AND EXHIBITION

RESEARCH QUESTION

How can an **open-depot** be designed as a space that offers a new dimension to the art experience and at the same time facilitate future **change** of the art collection?

1. INTRODUCTION

2. RESEARCH

3. DESIGN BRIEF

4. DESIGN

ambitions

solutions

implementation

5. CONCLUSION

CLIENT, USER, COLLECTION

CLIENT



Stiftung
Preußischer Kulturbesitz



Design Brief

CLIENT



**Stiftung
Preußischer Kulturbesitz**

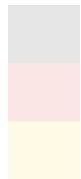

Gemäldegalerie
Staatliche Museen zu Berlin



Kupferstichkabinett
Staatliche Museen zu Berlin



Kunstbibliothek
Staatliche Museen zu Berlin



Kunstgewerbemuseum
Staatliche Museen zu Berlin

Design Brief

AMBITIONS

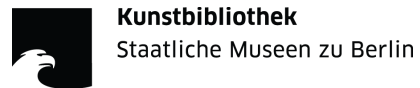
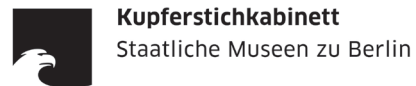
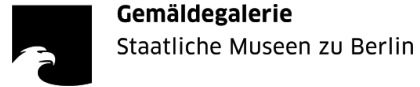
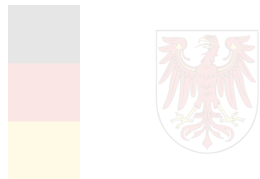
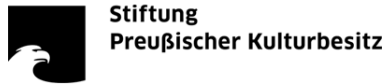

Ambitions



Sustainable + secure care
of collections



Recognizable icon



Pioneer in art scene

Design Brief

COLLECTIONS



**Stiftung
Preußischer Kulturbesitz**

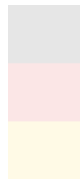

Gemäldegalerie
Staatliche Museen zu Berlin



Kupferstichkabinett
Staatliche Museen zu Berlin



Kunstbibliothek
Staatliche Museen zu Berlin



Kunstgewerbemuseum
Staatliche Museen zu Berlin



data per building

visitors: 310.000 / yearly
collection: 3.600 paintings
material: canvas / wood



visitors: 35.000 / yearly
collection: 110.000 drawings
550.000 prints
material: canvas / papyrus

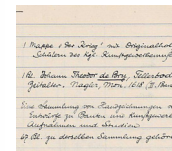

visitors: 35.000 / yearly
collection: 400.000 books
material: canvas / papyrus



visitors: 51.000 / yearly
collection: 600 costumes
900 furniture
material: textile / wood /
ivory, metals
ceramics, glass

Design Brief

USER PROFILE

VISITORS

- 1. Locals**
- 2. Tourists**
- 3. Educational**
- 4. Employees**

LOCALS

Visitors from Berlin
/ Germany
Speak the German

TOURISTS

International visitors
from abroad
Speak the German

EDUCATIONAL

Primary school
High school
University

EMPLOYEES

Art handlers
Restoration experts
Administration
management
Guides
Technical staff
Security staff
Cleaning staff
BOD staff

Design Brief

USER AMBITION

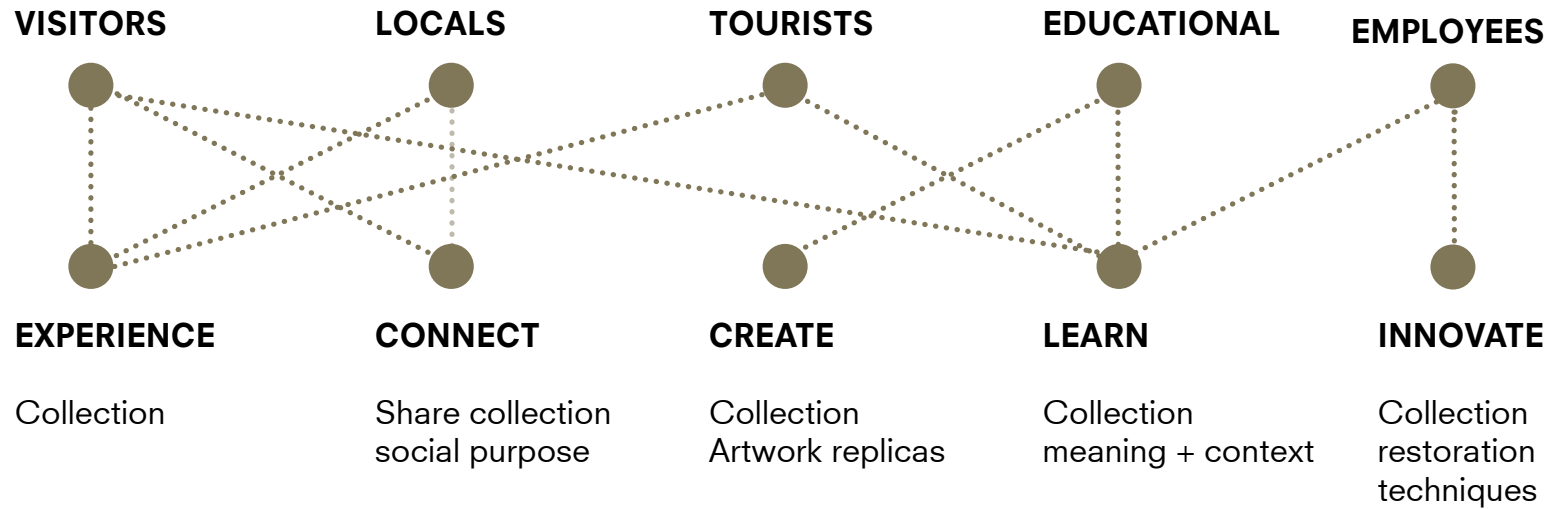

SITE

Site
URBAN VISION

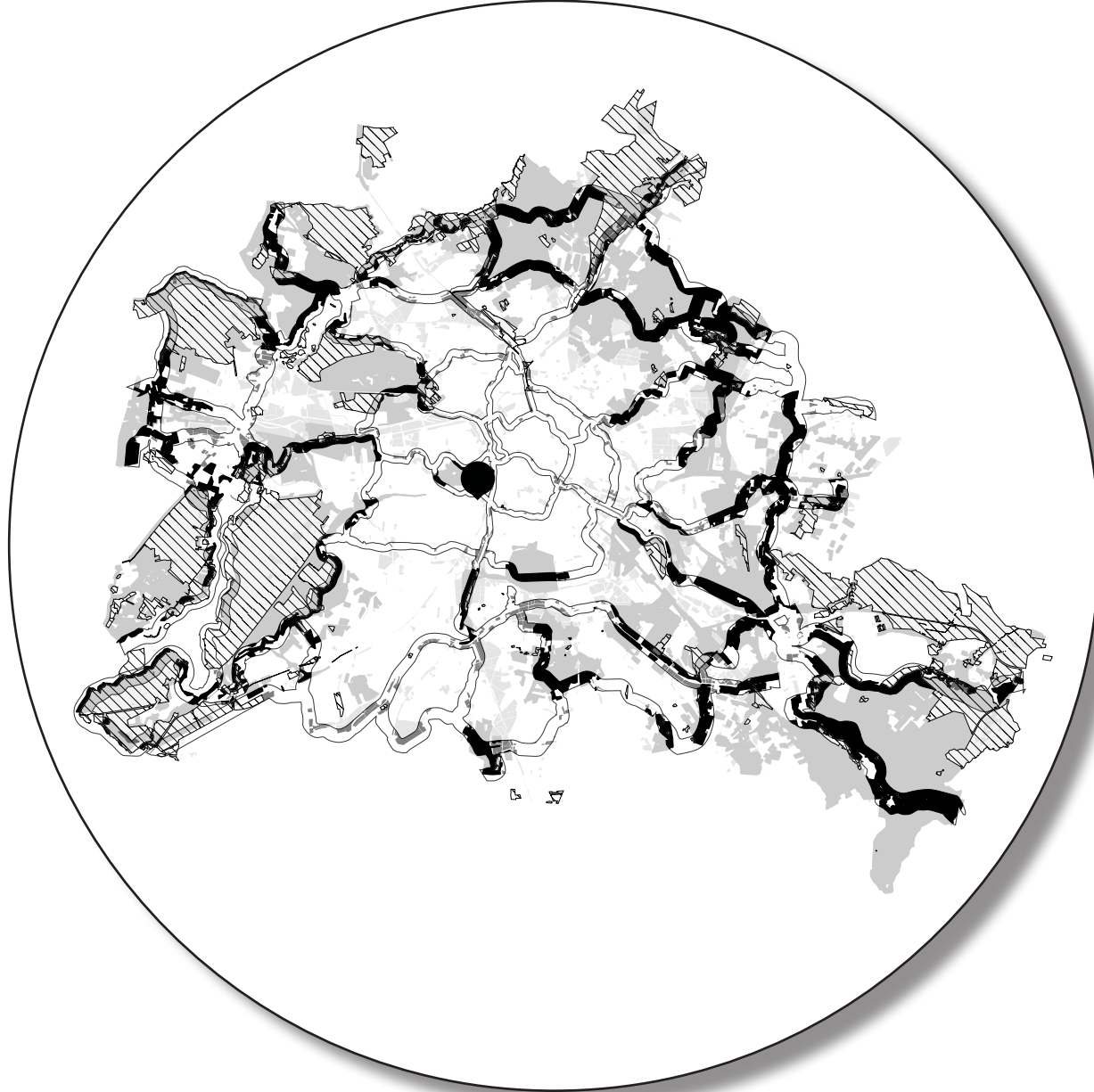

Site CRITERIA'S



Criteria I
In or next to greenery



Criteria II
Connected to green corridor



Criteria III
Not in protected environment

Site

MUSEUM CLUSTERS

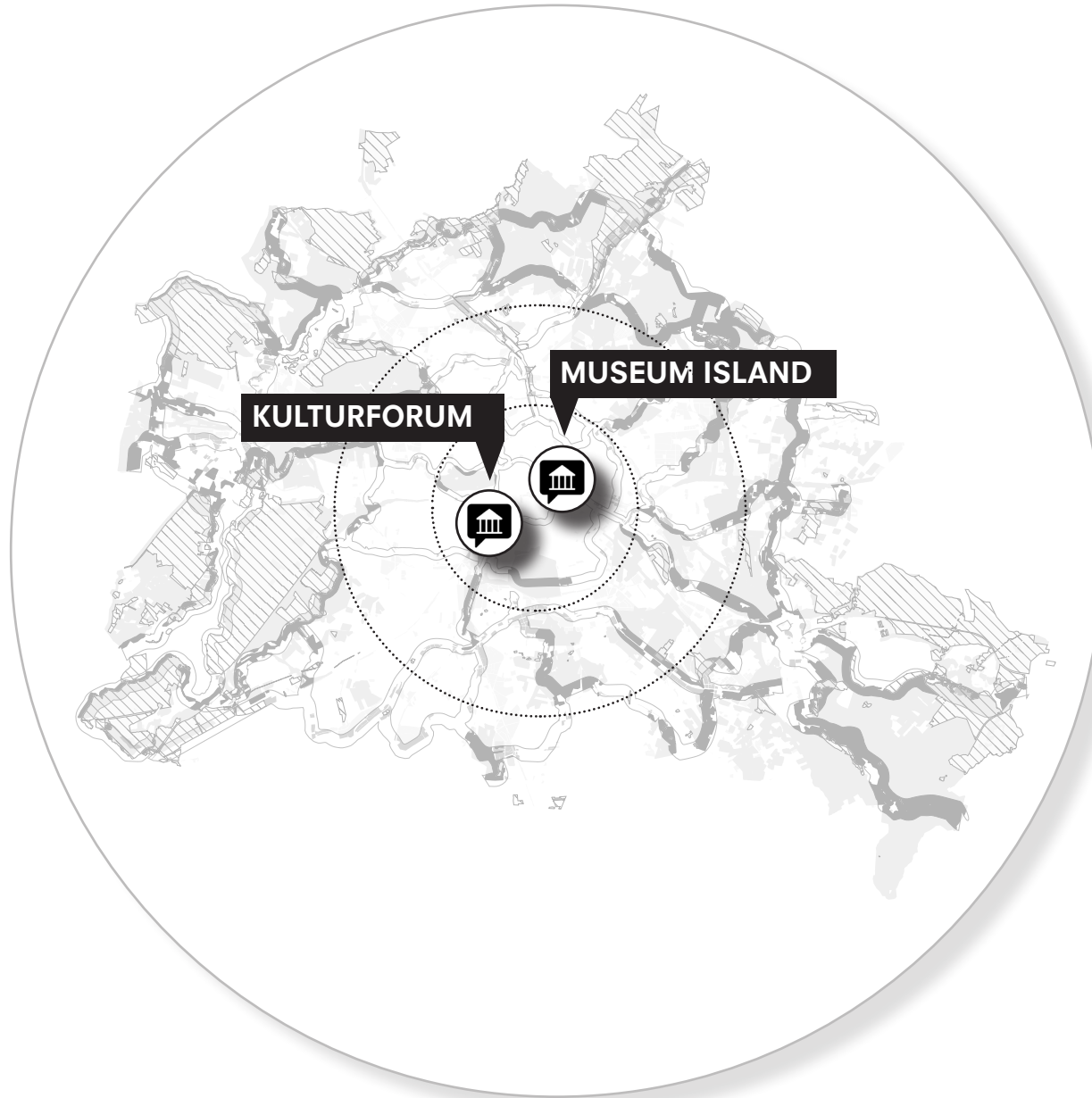

Site

MUSEUM CLUSTERS



Site TIMELINE



Bombing and extensive destruction of Tiergarten district

Reconstruction of **St. Matthew's Church** (originally built in 1846)



Philharmonie by Hans Scharoun

New National Gallery by Ludwig Mies van der Rohe



Construction of the **Arts and crafts museum** by Rolf Gutbrod

Kammermusiksaal (Chamber Music Hall) by Edgar Wisniewski,



Kupferstichkabinett (Museum of Prints and Drawings) and **Kunstbibliothek** (Art Library) opened

Piazza is studied because of problems. Use is for storage, however there is parking shortage



Museum of The 20th Century design Herzog and de Meuron

Your 20-min Artdepot

1943-1945

1956

1963

1968

1978-1985

1987

1994

1999

2016

2030

1940-1950

1950-1960

1960-1970

1970-1980

1980-1990

1990-2000

2000-2010

2010-2020

2020-2030

1946

1961

1968

1967-78

1984-1985

1989

1998

2010

2020 - 2026

Collective plan, among others by Prof. H. Scharoun, with ideas for **complete redesign of Berlin**

Wall construction, construction of the "Relief Road" through the Tiergarten (now primary road, B1)

New National Gallery by Ludwig Mies van der Rohe

Construction of the **New State Library** (Stabi) according to Scharouns design

Musikinstrumentenmuseum by Edgar Wisniewski. **Kunstgewerbe museum**, Museum of Decorative Arts was designed by Gutbrod

Fall of the **Wall**

Gemäldegalerie (Old Master Paintings) opened

Site Museum of The 20th Century exchanged for site Tiergartenstrasse 10

Construction of Museum of The 20th Century





Site
KULTURFORUM

KULTURFORUM
1.2 ha

PLOT SIZE
8.000 sqm



Site

CULTURAL PROGRAM

Sony Complex
Helmut Jahn
1995 - 2000

Kollhoff Tower
Hans Kollhoff, Renzo Piano
1998 - 1999

BahnTower
Helmut Jahn
1998-99

Berlin State Library
Hans Scharoun
1967 - 1978

Philharmonic Hall Berlin
Hans Scharoun
1960 - 1963

Neue Nationalgalerie
Mies van der Rohe
1963 - 1968

Chamber Music Hall
Edgar Wisnewski
1984 - 1986

St. Matthew's Church
Friedrich August Stüler
1844- 1846

Musical Instruments Museum
Edgar Wisnewski
1979 - 1984

Berlin Art Library
Rolf Gutbrod, Hilmer, Sattler
1978 - 1990

Museum of Decorative Arts
Rolf Gutbrod
1978 - 1985

Picture Gallery
Hilmer and Sattler
1992 - 1998

Piazzetta square
Rolf Gutbrod

Museum of Prints and Drawings
Rolf Gutbrod, Hilmer, Sattler
1978 - 1990

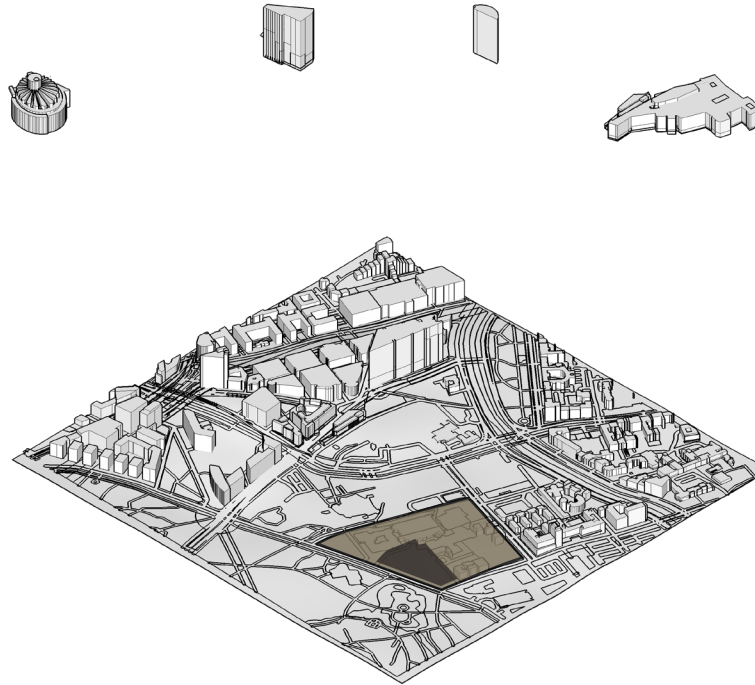

Isometry of existing buildings at the Kulturforum

Site

STORAGE PROBLEMS

Sony Complex
Helmut Jahn
1995 - 2000

Kollhoff Tower
Hans Kollhoff, Renzo Piano
1998 - 1999

BahnTower
Helmut Jahn
1998-99

Berlin State Library
Hans Scharoun
1967 - 1978

Philharmonic Hall Berlin
Hans Scharoun
1960 - 1963

Neue Nationalgalerie
Mies van der Rohe
1963 - 1968

Chamber Music Hall
Edgar Wisnewski
1984 - 1986

St. Matthew's Church
Friedrich August Stüler
1844- 1846

Musical Instruments Museum
Edgar Wisnewski
1979 - 1984

Berlin Art Library
Rolf Gutbrod, Hilmer, Sattler
1978 - 1990

Museum of Decorative Arts
Rolf Gutbrod
1978 - 1985

Picture Gallery
Hilmer and Sattler
1992 - 1998

Piazzetta square
Rolf Gutbrod

Museum of Prints and Drawings
Rolf Gutbrod, Hilmer, Sattler
1978 - 1990

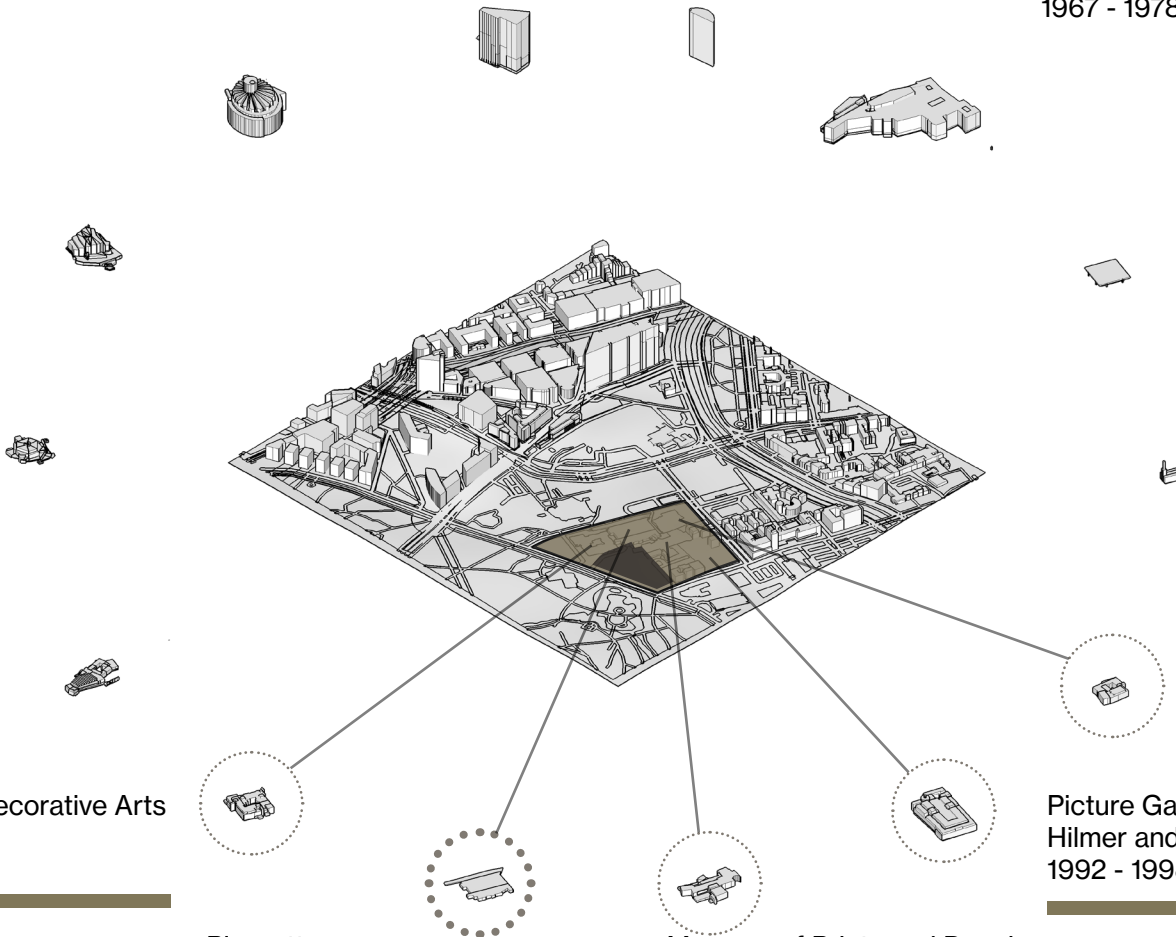

Isometry of existing buildings at the Kulturforum

Site ACCESSIBILITY

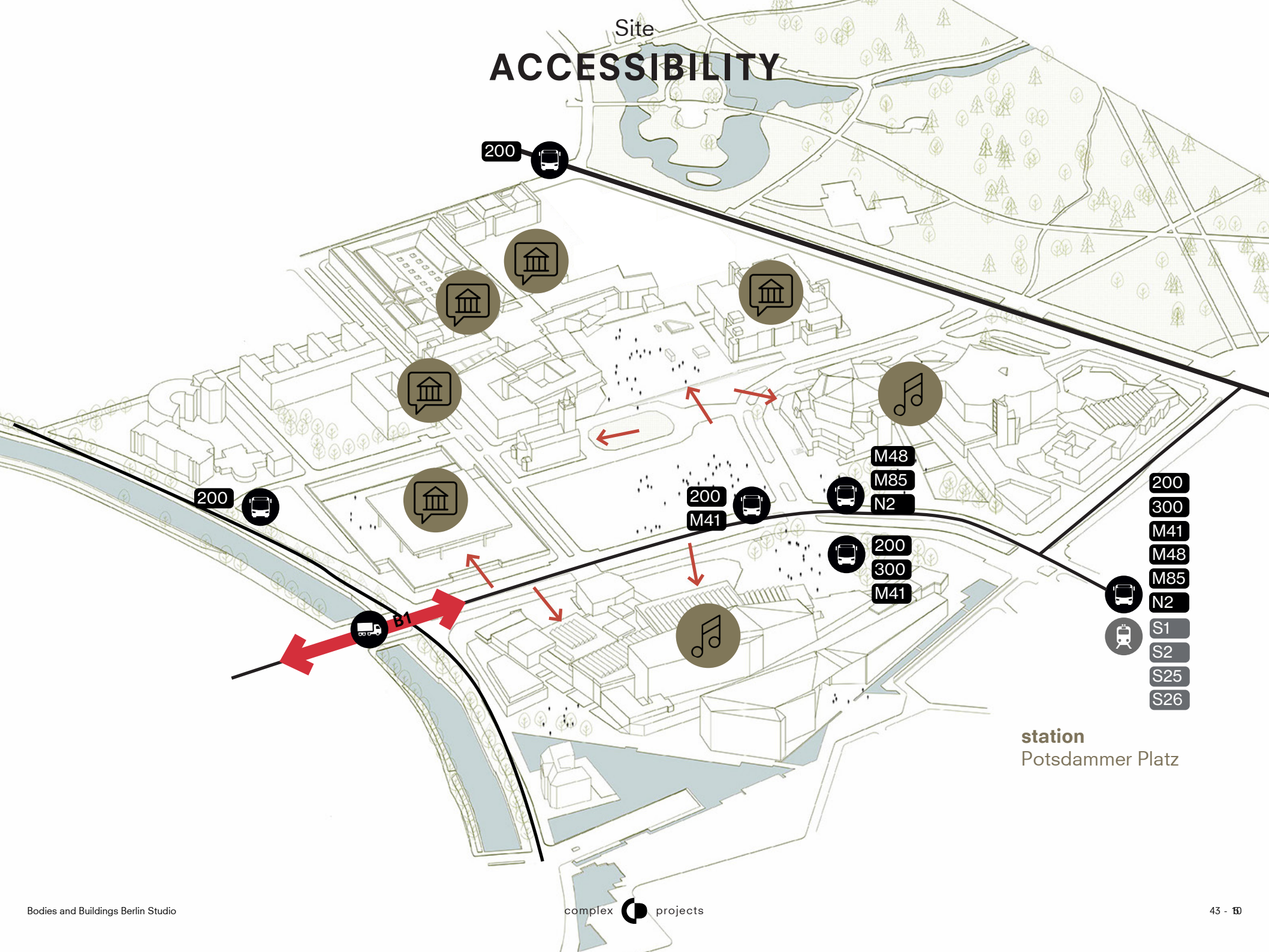

200

200

200
M41

M48
M85
N2

200
300
M41

200
300
M41
M48
M85
N2
S1
S2
S25
S26

station
Potsdamer Platz

WALKABLE AXES

Site

city park
Tiergarten

waterfront
Neukolnerr canal

walkable distance
10 minutes

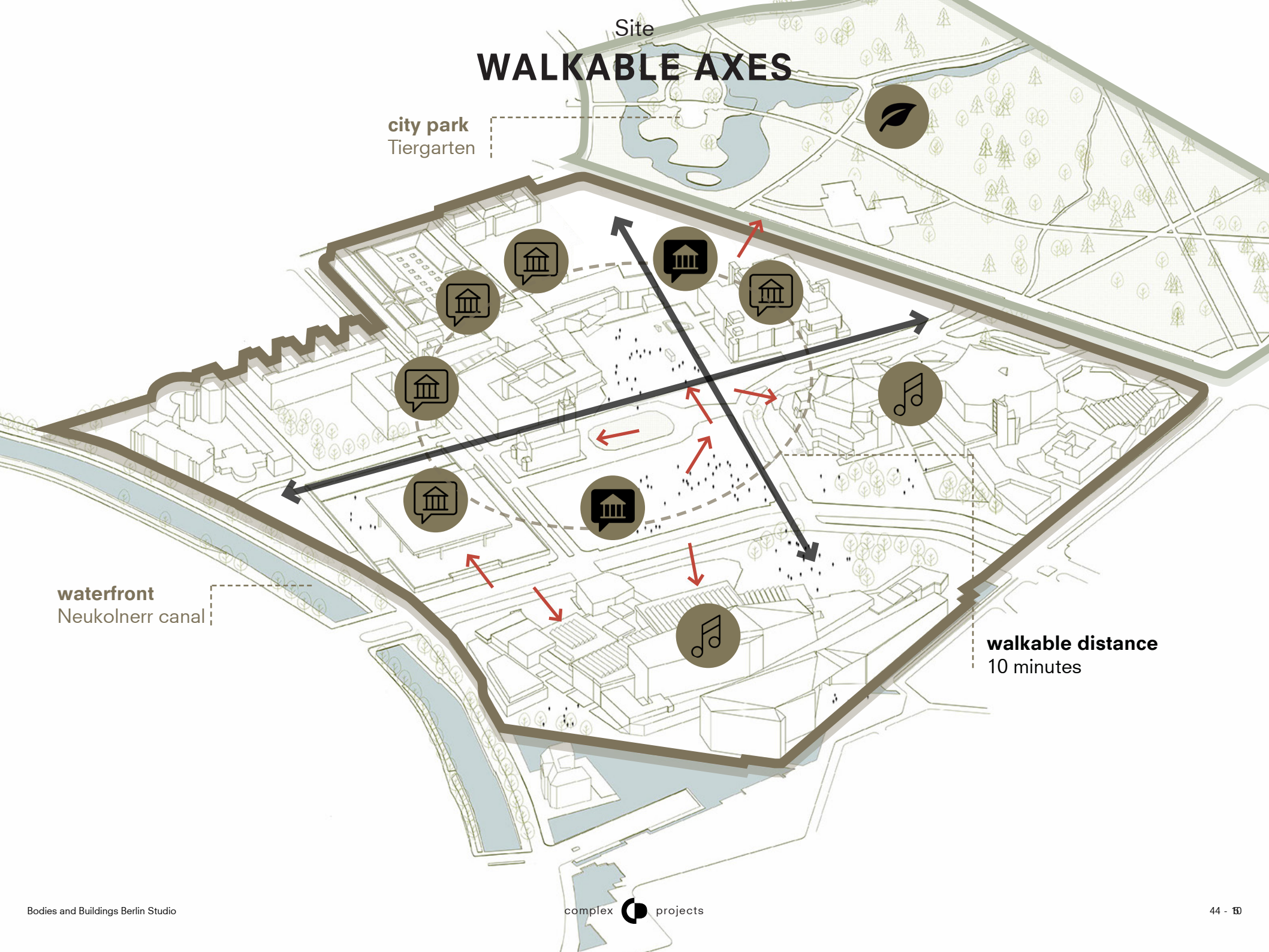

Site
ACCESSIBILITY POTENTIAL

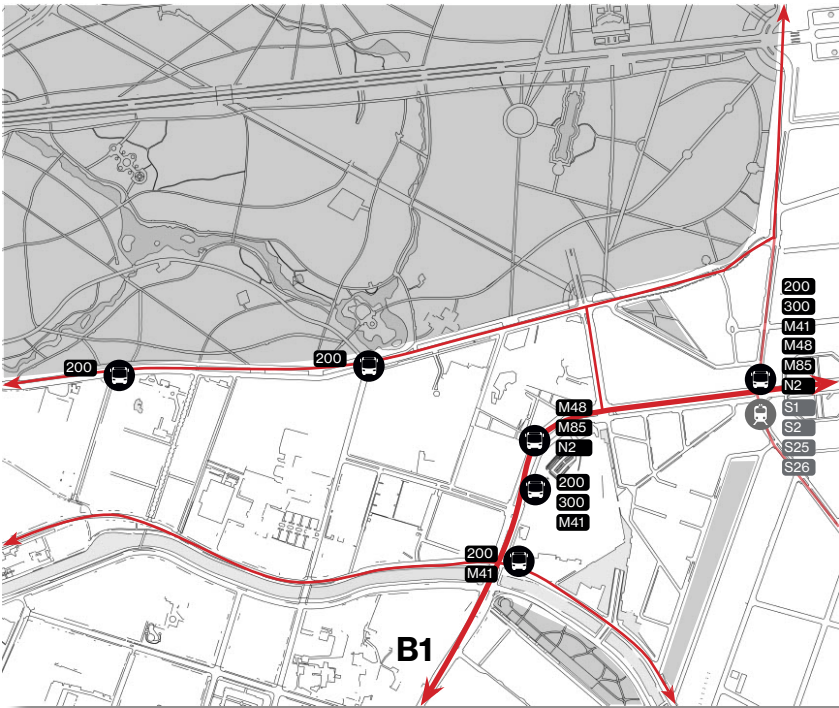

Site
GREEN POTENTIAL

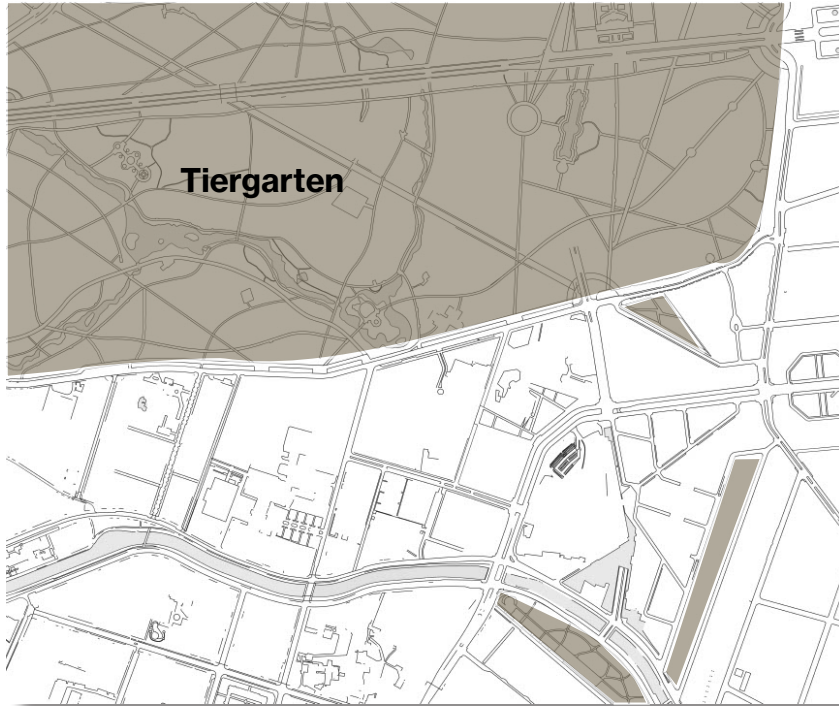

Greenery network

Site

PUBLIC SPACE POTENTIAL



Public square
Piazzetta
square at
Kulturforum

Site
SITE AMBITION



**Improve accessibility Tiergarten
and Kulturforum**



**Increase attractive
public space
at Kulturforum**



**Clear routing
at Kulturforum**

PROGRAM

Program

PROGRAM BERLIN OPEN DEPOT

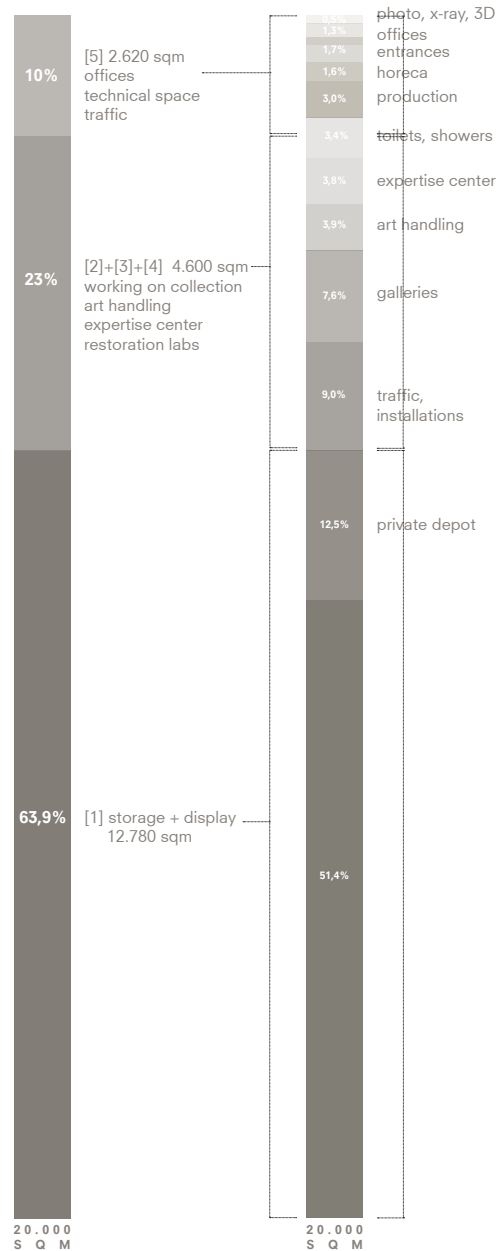

ART HANDLING



RESTORE



STORAGE

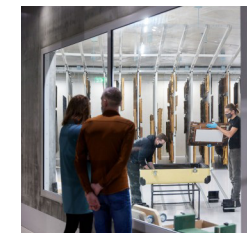

EXPERIENCE

Pictures: Boijmans van Beuningen (2019) by MVRDV

Program

PROGRAMMATIC RELATIONS

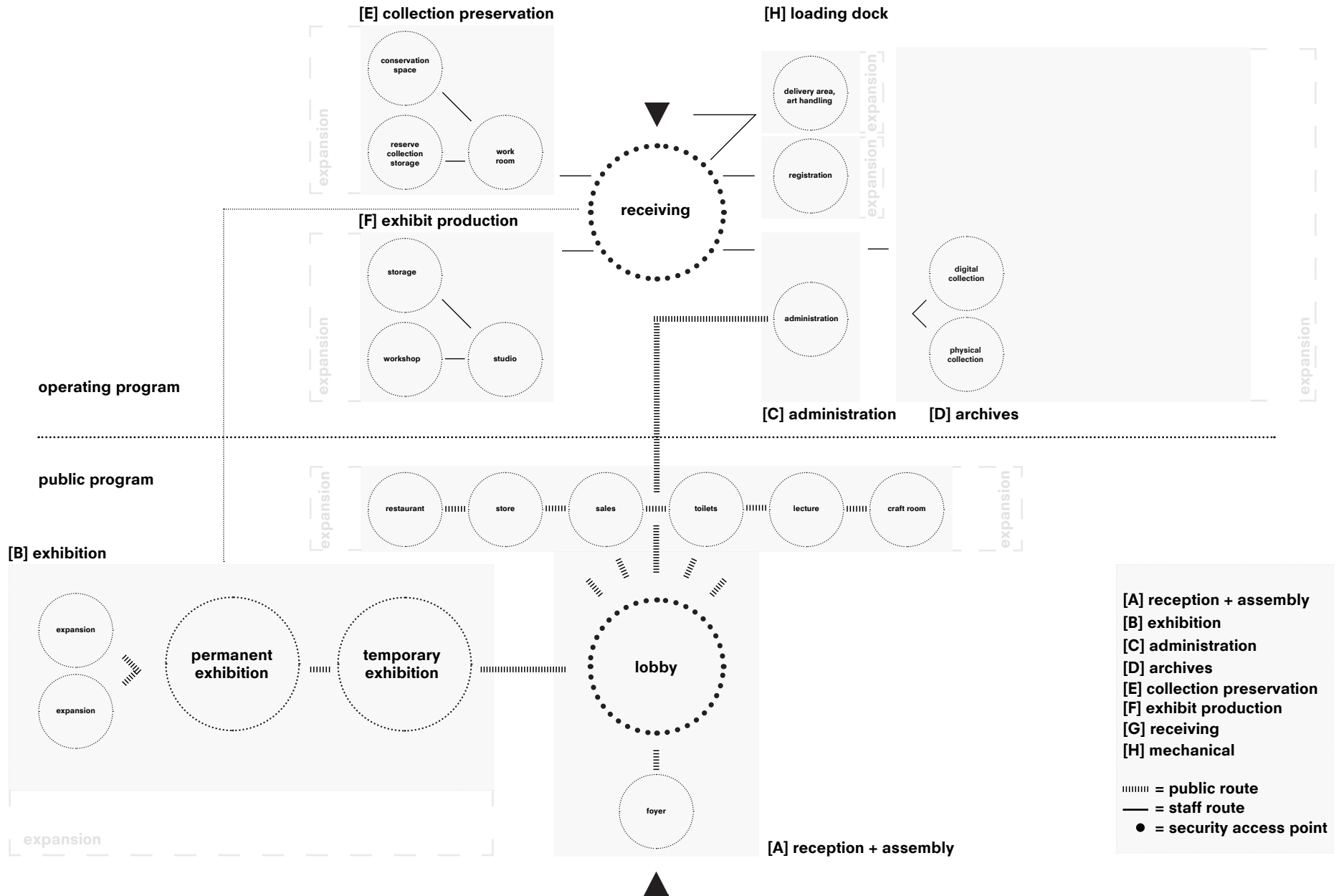

Program

PROGRAMMATIC RELATIONS

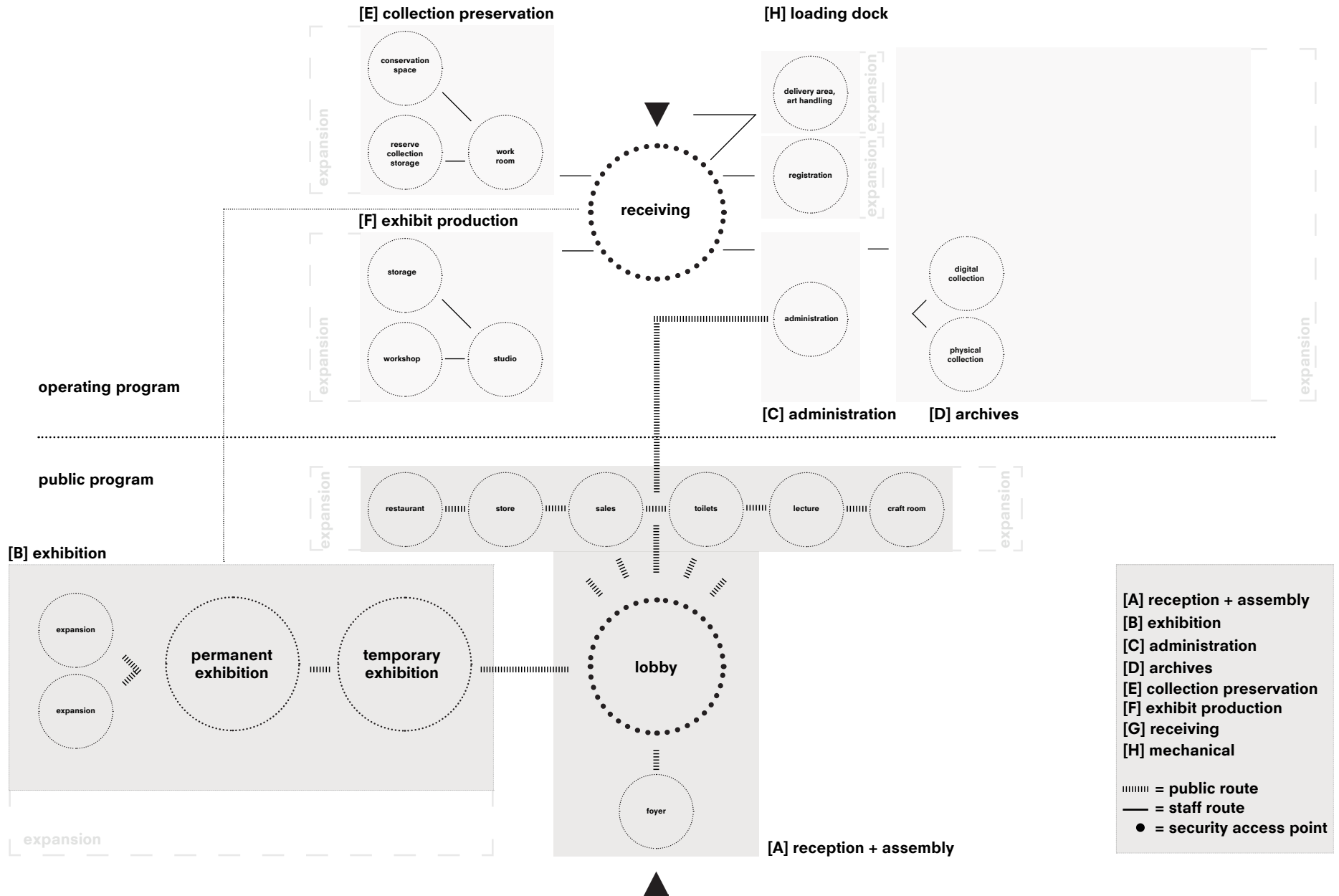

Program

CRITICAL SPACES

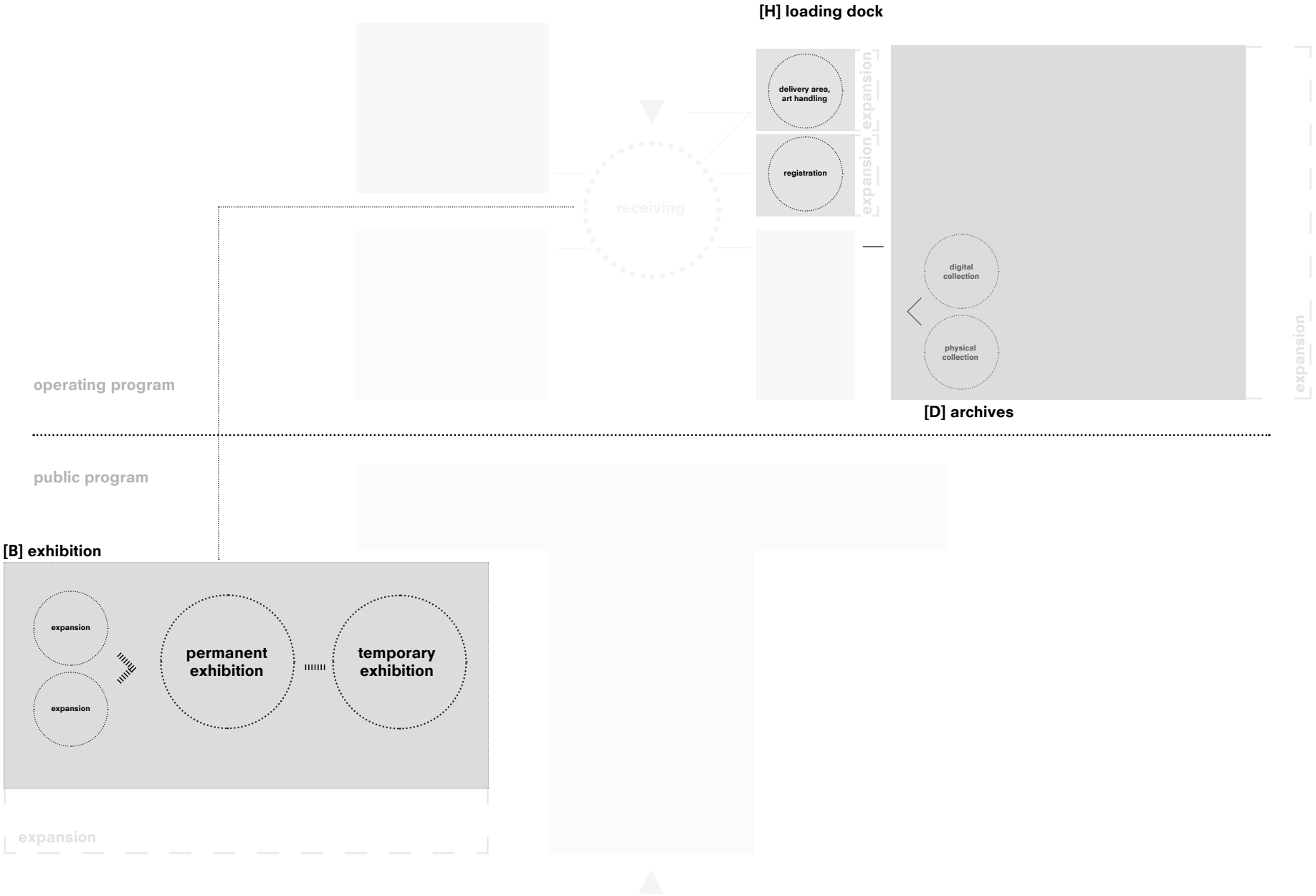

Program

CRITICAL SPACES

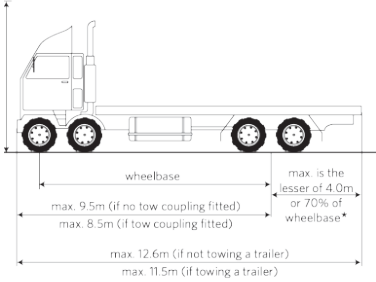

*see notes if fitted with a rear steering axle



loading dock

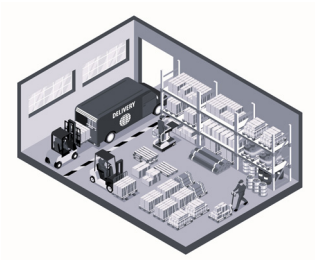

Program

CRITICAL SPACES

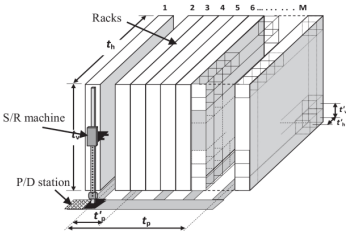
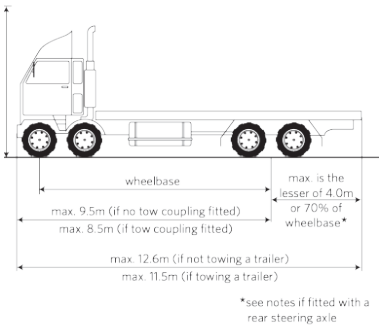

loading dock



storage depot

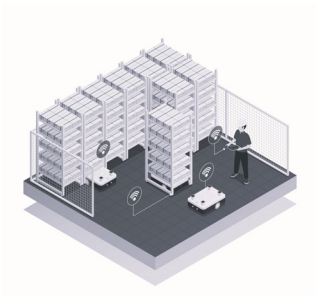
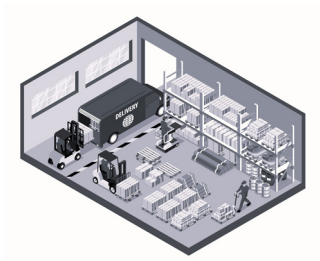

Program CRITICAL SPACES

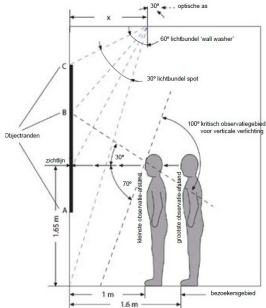
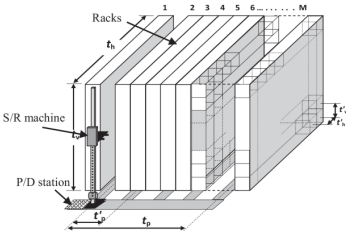
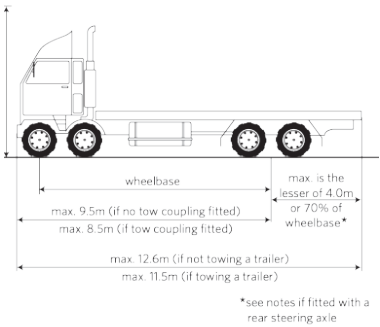

loading dock

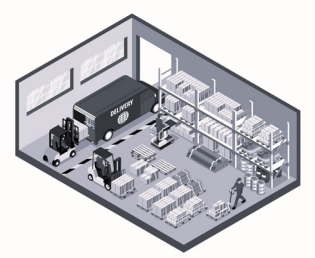

storage depot

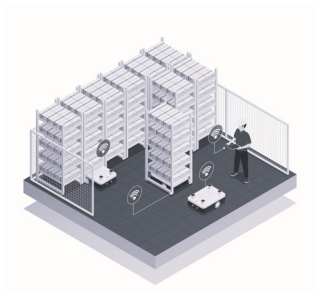

exhibition hall



CLIENT, SITE & PROGRAM



Client

Stiftung
Preussischer
Kulturbesitz
(SPK), Prussian
Cultural Heritage
Foundation

Site

Kulturforum,
Berlin,
Germany

Program

20.000 sqm
Storage + Display

1. INTRODUCTION

2. RECAP DESIGN BRIEF

3. CONCEPT

4. DESIGN

ambitions

solutions

implementation

5. CONCLUSION

Concept MODEL STUDIES

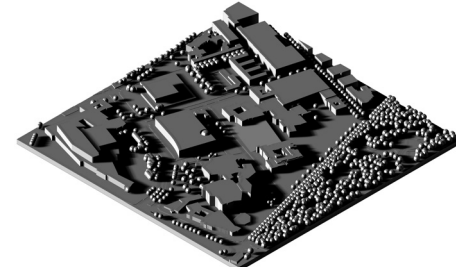
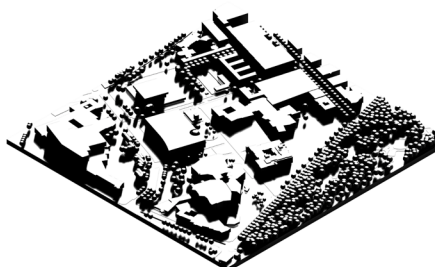
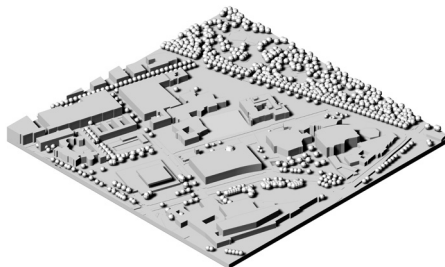
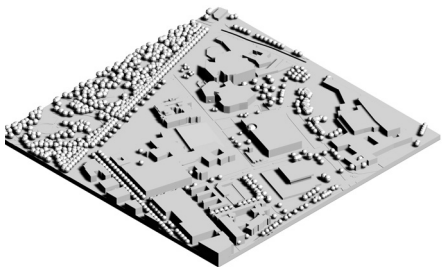

whole plot

pro's & con's

- + Denmark model possible
- + Easy for storage
- Low public space
- Low access Tiergarten
- Low visibility as volume is low
- Blocking access of surrounding buildings

80% plot

pro's & con's

- + Equals buiding height context
- Low visibility
- Low public space
- Low access Tiergarten

60% plot

pro's & con's

- + High visibility
- + Efficient storage solution
- + Possibilities for public space
- + Compactness energy efficient
- + Monumental plot ratio

40% plot

pro's & con's

- + High visibility
- + Possibilities for public space
- Little ground floor space
- Above limit max. building height

Concept

CLIENT AMBITIONS

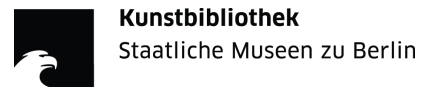
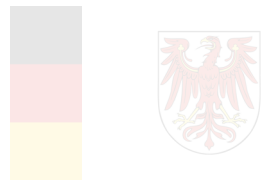

Ambitions



Sustainable + secure care
of collections



Recognizable icon



Pioneer in art scene

Concept

CLIENT AMBITIONS

- 1** Improve accessibility Tiergarten - Kulturforum
- 2** Introduce a new landmark
- 3** Activate green lines introduced by the city's urban vision

Concept
CONNECT



TIERGARTEN

1

site situation - building in urban system 1:5000 ⓘ

Concept
CONNECT

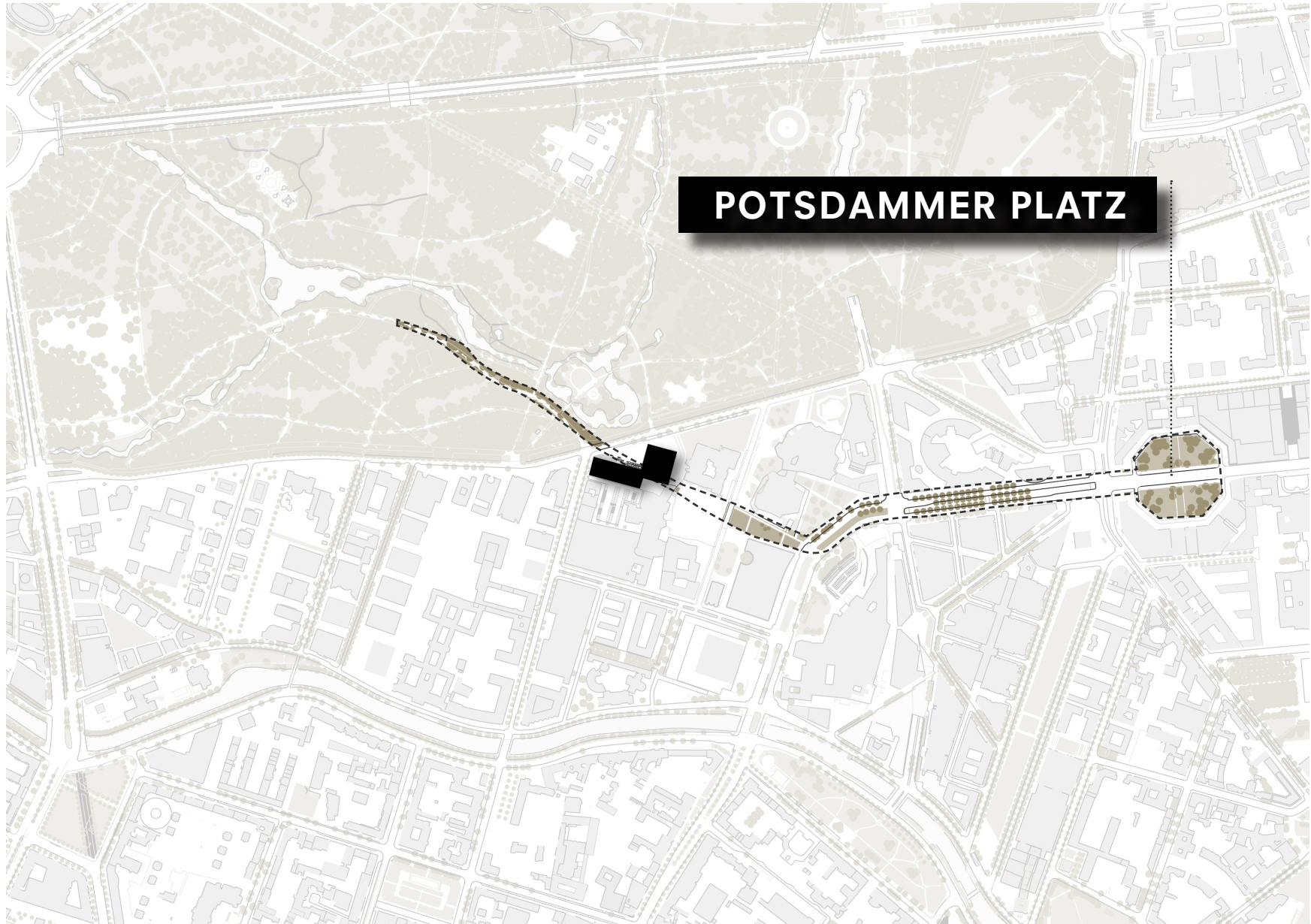

1

site situation - building in urban system 1:5000 

Concept
CONNECT

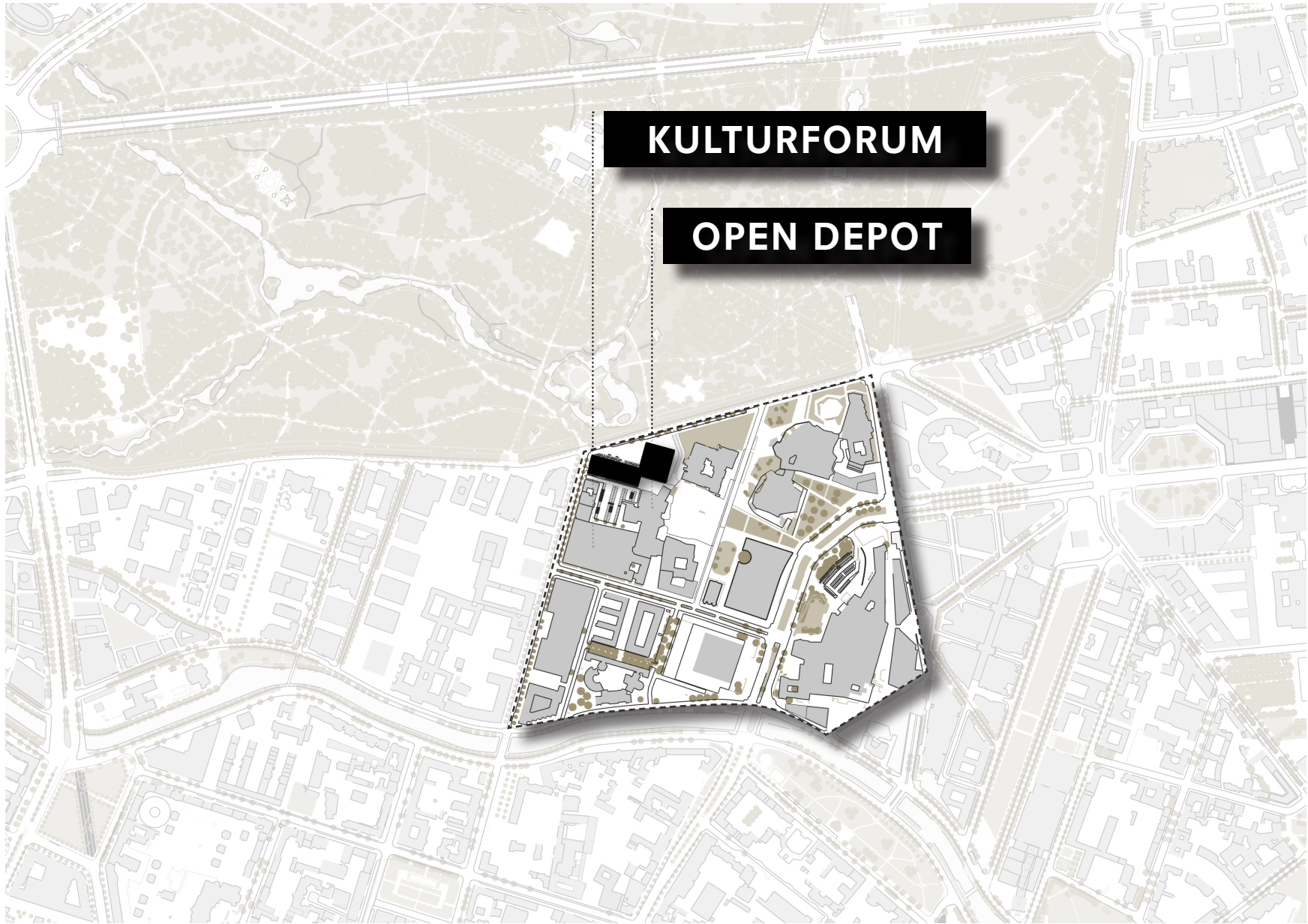

1

site situation - building in urban system 1:5000 

Concept

CONNECT EXISTING VALUES



1

site situation - building in urban system 1:5000 
ambition: connection Tiergarten - Kulturforum

Concept

RECOGNIZABLE ICON

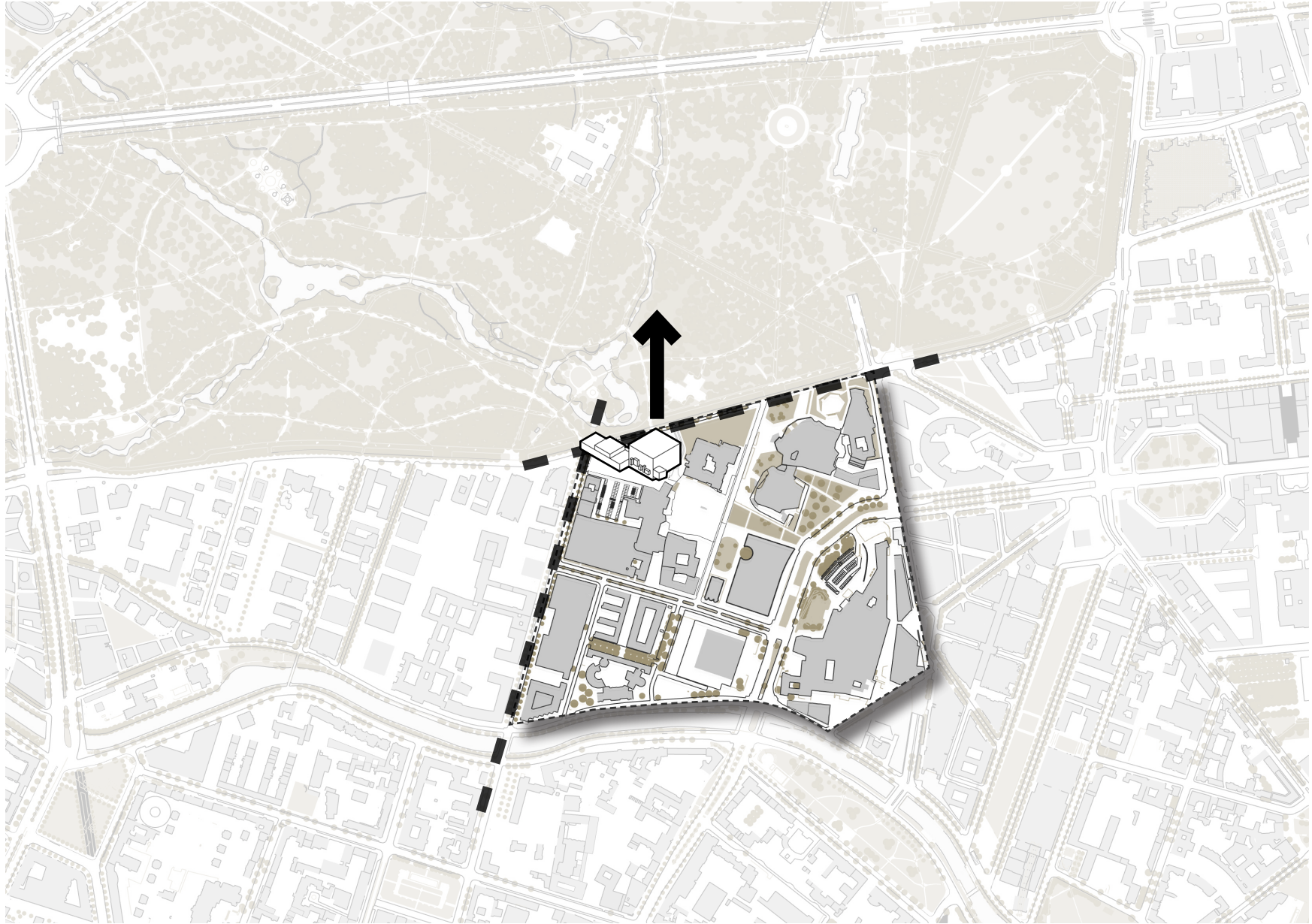

2

site situation - building in urban system 1:5000 ⓘ
ambition: landmark

Concept

ACTIVATE GREEN CORRIDOR

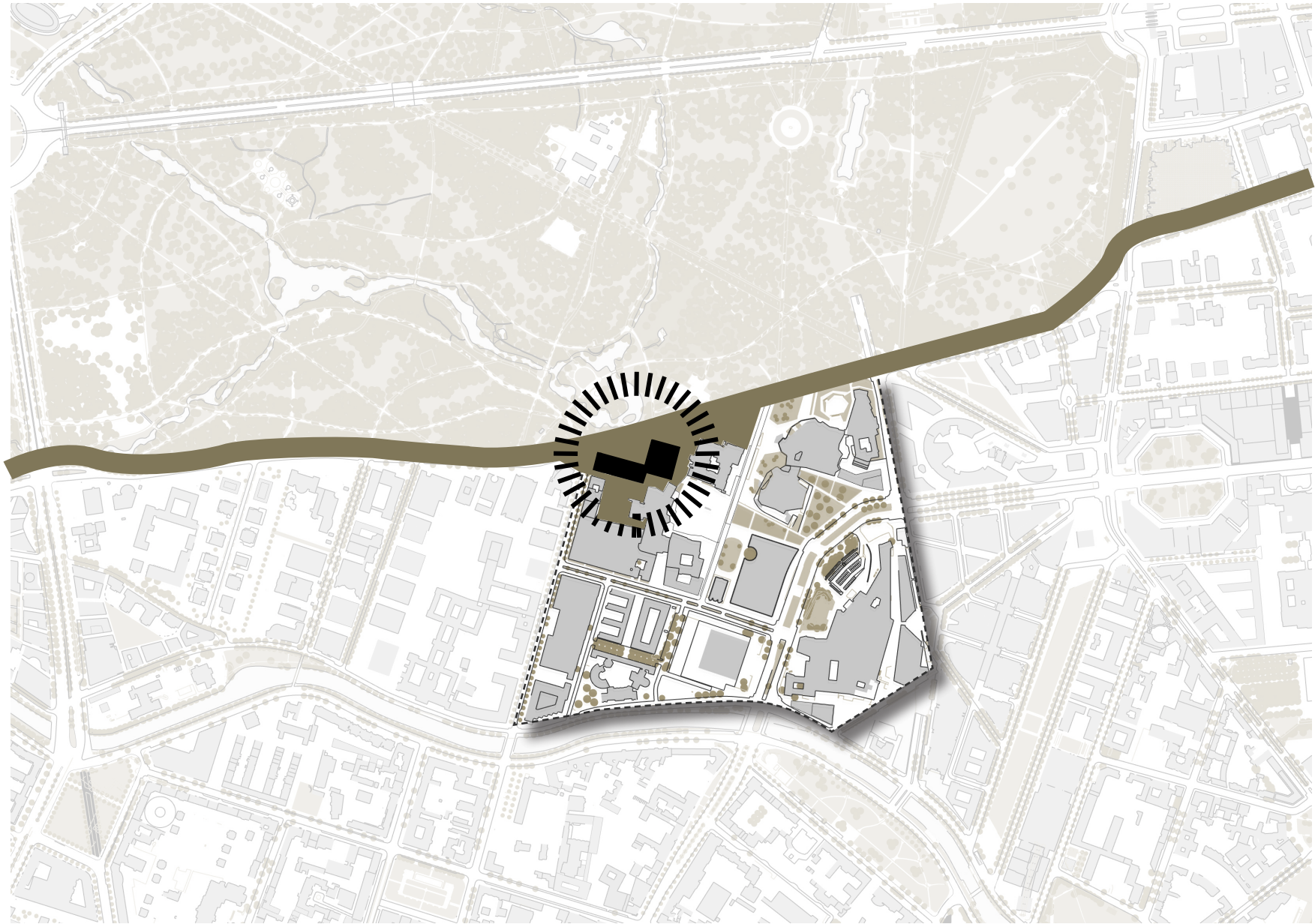

3

site situation - building in urban system 1:5000 
ambition: activate green lines of urban vision

Concept

MODEL STUDIES

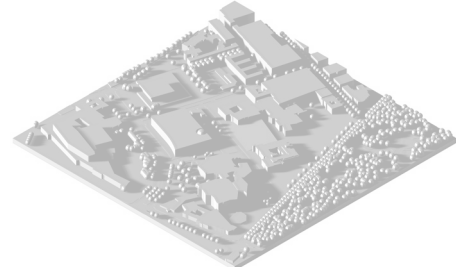
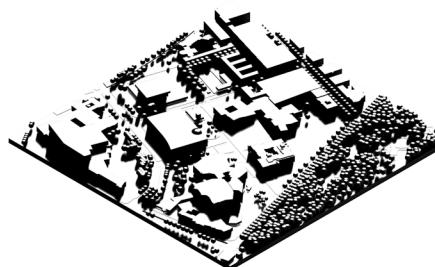
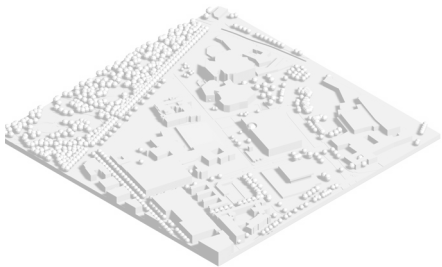

whole plot

pro's & con's

- + Denmark model possible
- + Easy for storage
- Low public space
- Low access Tiergarten
- Low visibility as volume is low
- Blocking access of surrounding buildings

80% plot

pro's & con's

- + Equals buiding height context
- Low visibility
- Low public space
- Low access Tiergarten

60% plot

pro's & con's

- + High visibility
- + Efficient storage solution
- + Possibilities for public space
- + Compactness energy efficient
- + Monumental plot ratio

40% plot

pro's & con's

- + High visibility
- + Possibilities for public space
- Little ground floor space
- Above limit max. building height

Concept

PLOT CONSTRAINTS

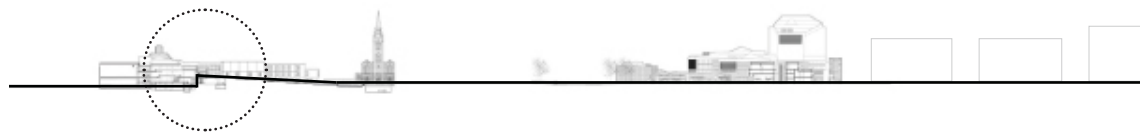

HEIGHT DIFFERENCE

Concept

PLOT CONSTRAINTS

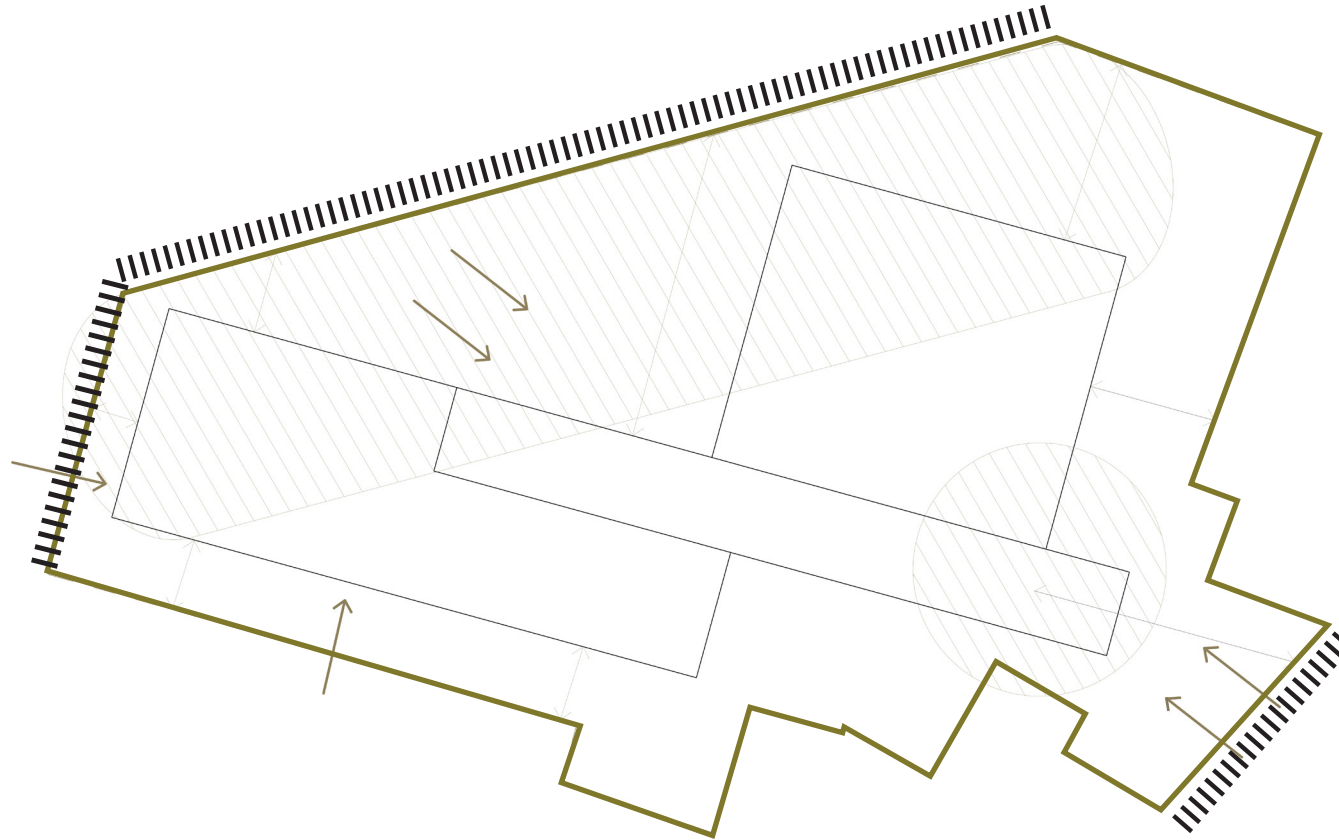

Offset: maximize potential of plot for greenery + facilities, reach monumentality

Entrances: oriented towards existing streets and parking

Facades: facing public plaza and Tiergarten to invite from both sides

PLOT CORNER

Concept

BERLIN OPEN DEPOT



Concept
KEY SPACES



EXHIBITION + DEPOT



Concept

PROJECT GOAL **UNLOCK THE SAFE**

DEPOT

EXHIBITION



Concept

PROJECT GOAL **UNLOCK THE SAFE**

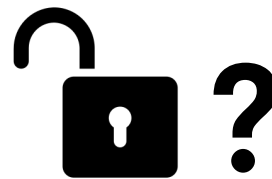

DESIGN CHALLENGES

1. SECURITY
2. VISIBILITY
3. CONNECTION TIERGARTEN - KULTURFORUM
4. LOGISTICS
5. FLEXIBLE FUNCTIONAL SEPARATION
6. CLIMATE-TECHNICAL

Concept
1. SECURITY

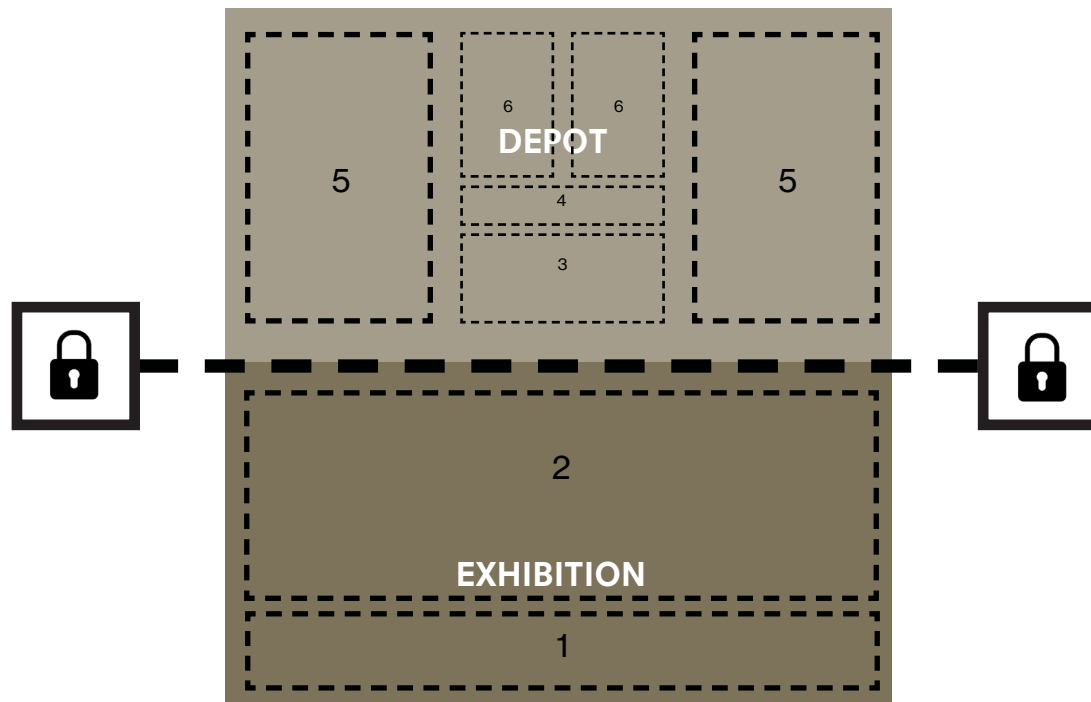

Security zones

- 1 Public zone
- 2 Restricted public zone
- 3 Standard zone
- 4 Secure zone I
- 5 Secure zone II
- 6 High secure zone

TWO MAIN ZONES

Concept
2. VISIBILITY

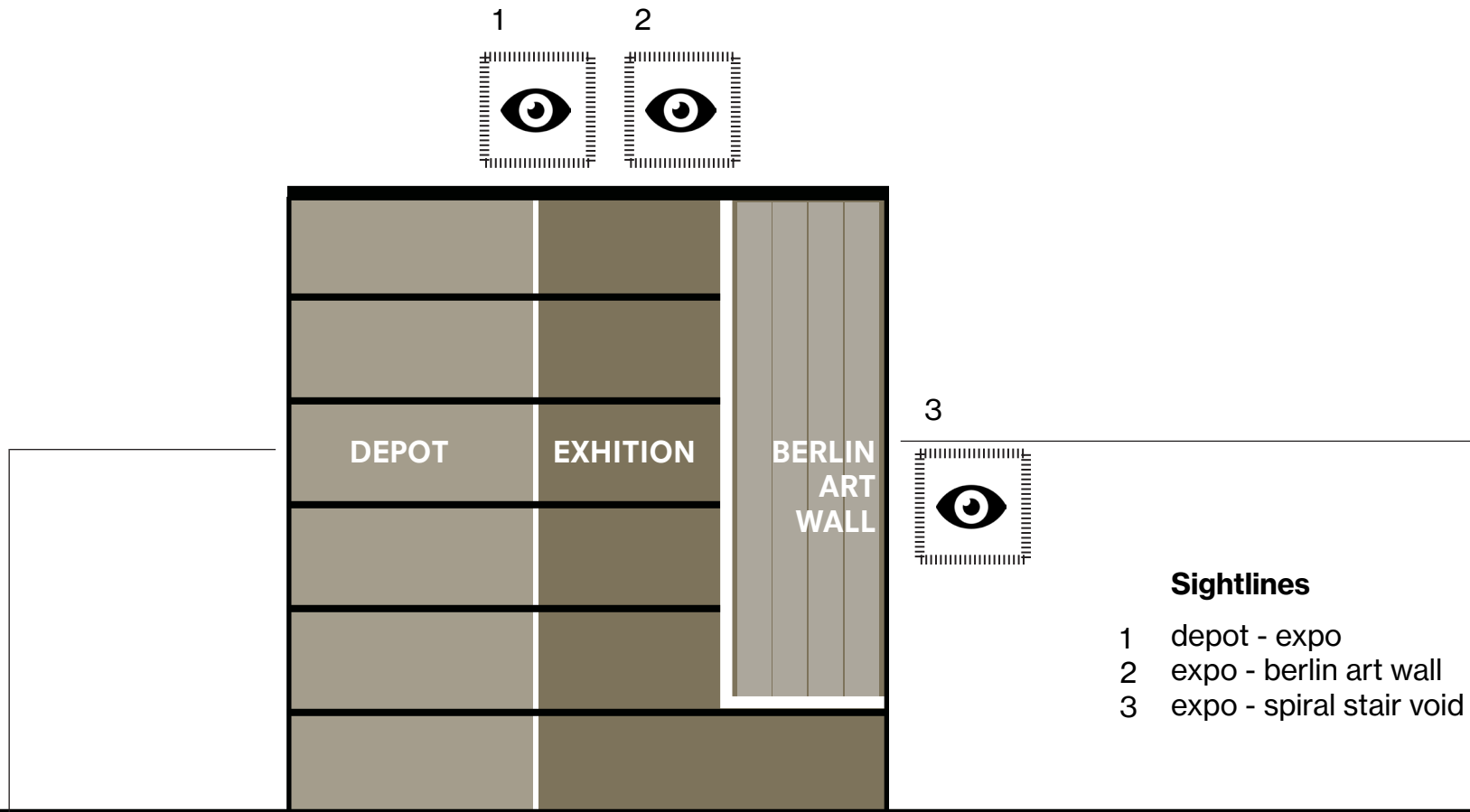

EXHIBITION STAGES

Concept

2. VISIBILITY - ART BALCONY

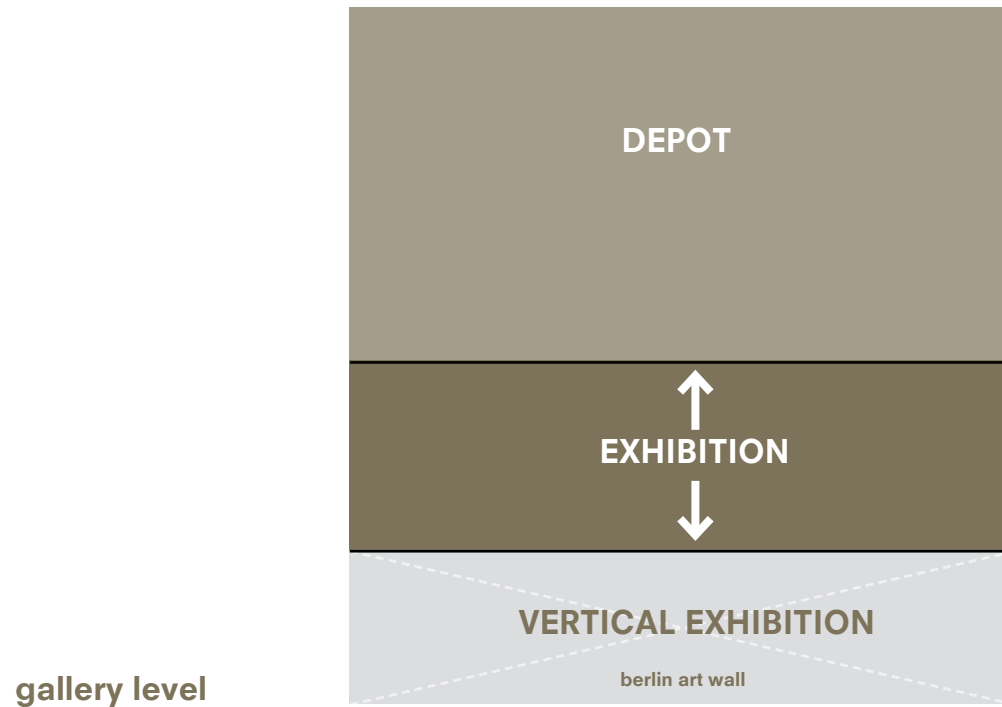

DOUBLE VISIBILITY

Concept
2. VISIBILITY

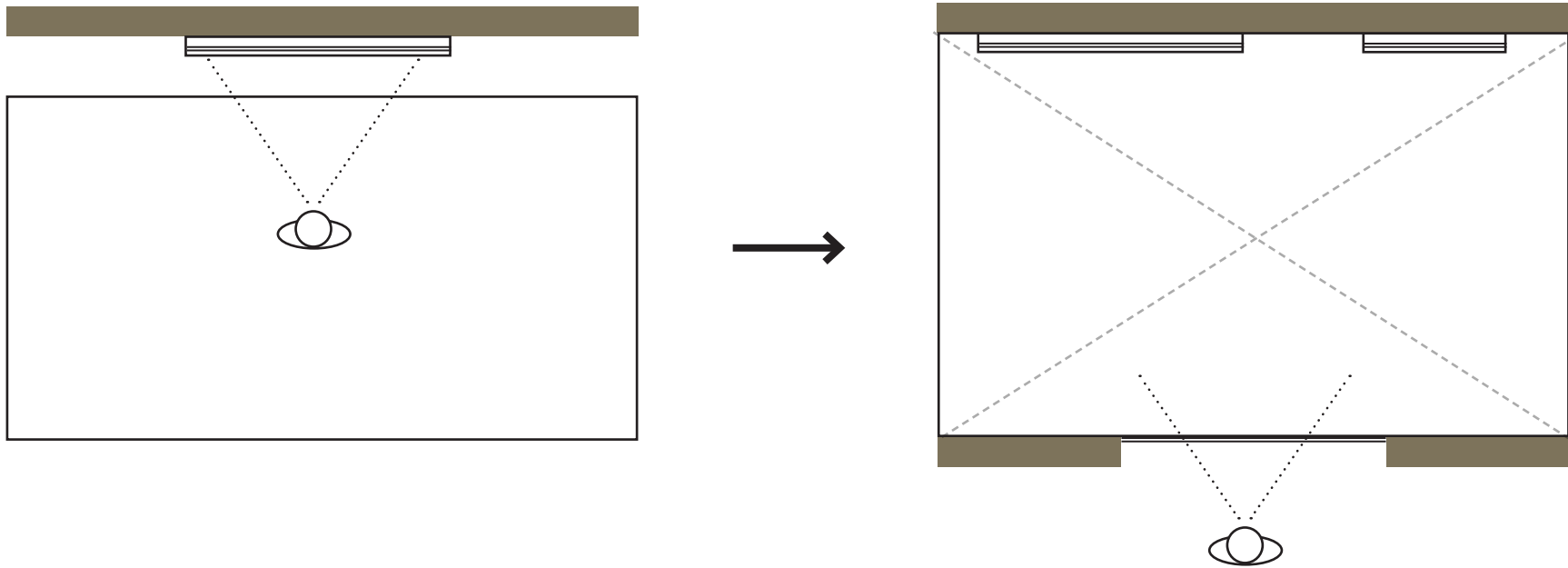

VERTICAL ART VITRINE: NEW PERSPECTIVE

3. CONNECTION TIERGARTEN - KULTURFORUM

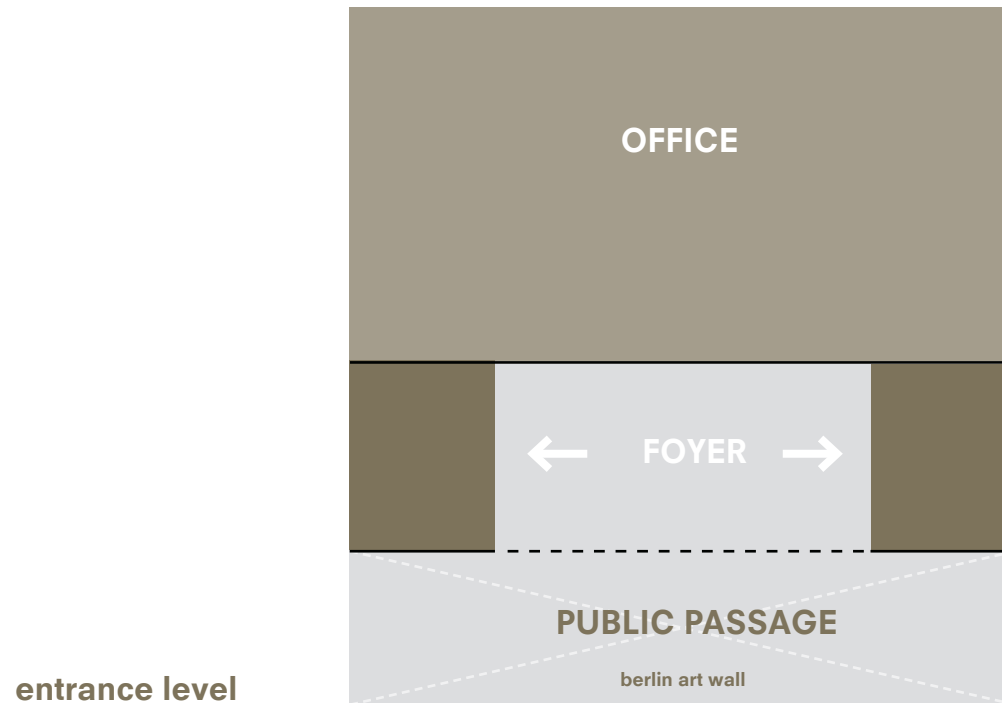

PUBLIC INDOOR STREET

Concept

4. LOGISTICS

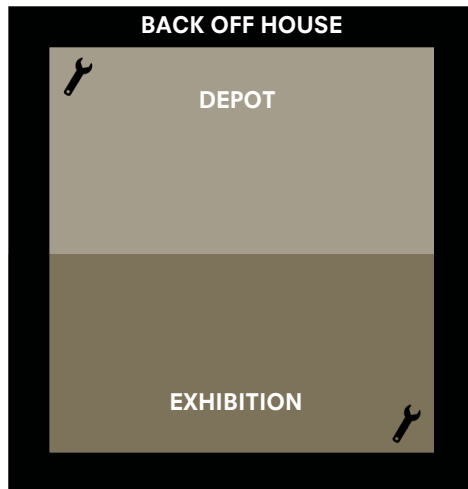

1. BACK OFF HOUSE AROUND

blocking views
blocking daylight

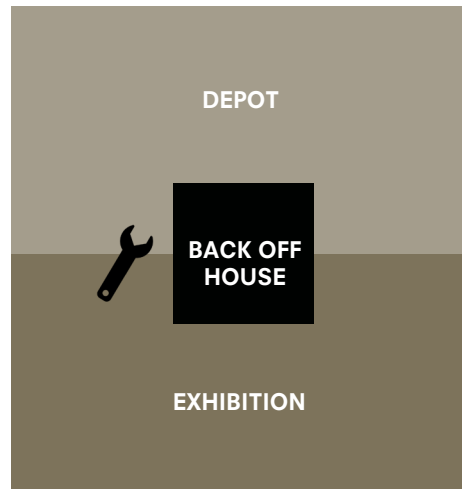

2. BACK OFF HOUSE CENTRALIZED

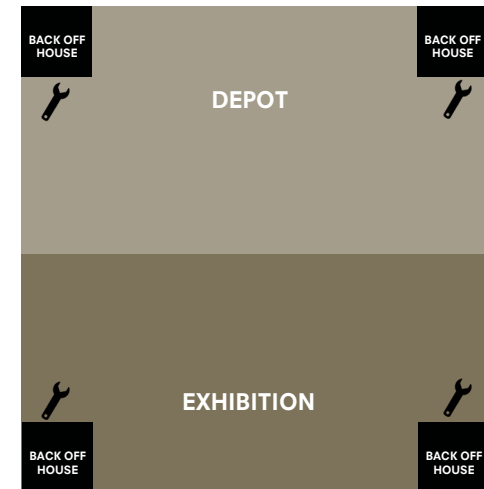

3. BACK OFF HOUSE DECENTRALIZED

problematic for climate, security, logistic efficiency

SERVICE BLOCK

Concept
4. LOGISTICS



1. BACK OFF HOUSE AROUND

blocking views
blocking daylight

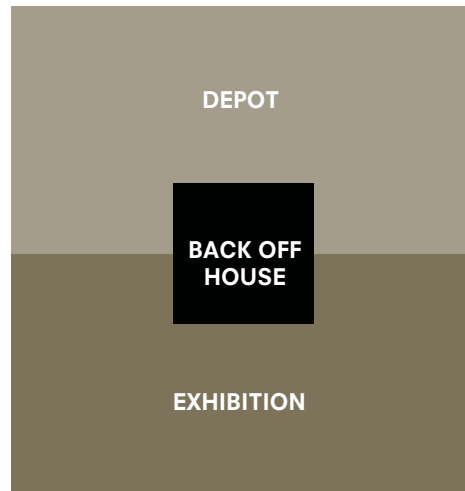

2. BACK OFF HOUSE CENTRALIZED



3. BACK OFF HOUSE DECENTRALIZED

problematic for climate, security, logistic
efficiency

CENTRALIZED

Concept

FLEXIBLE FUNCTIONAL SEPARATION

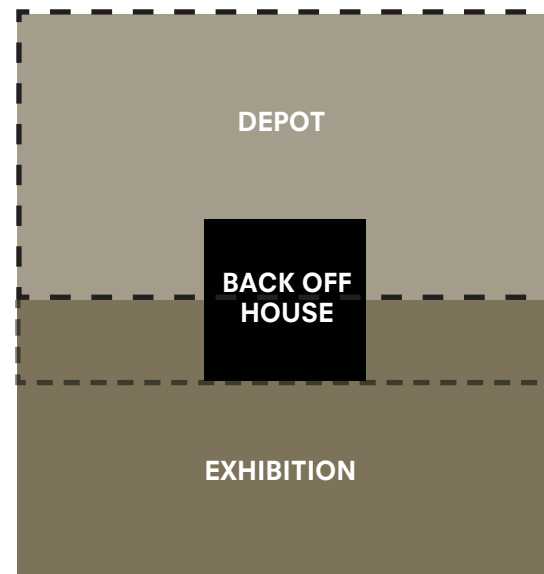

ADAPTABLE ZONE

6. CLIMATE TECHNICAL

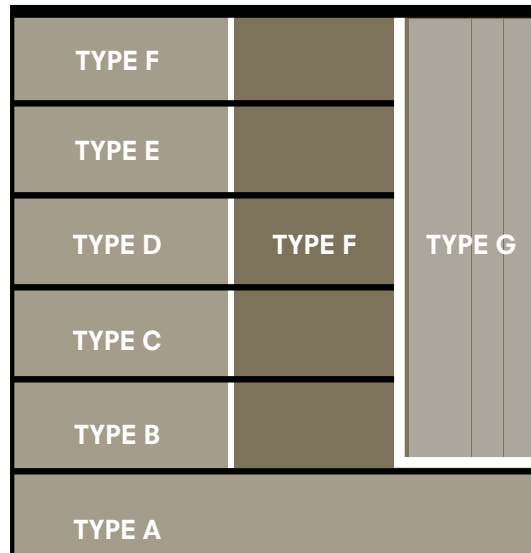

CLIMATE ZONES

DETAIL **OPTIMAL CLIMATE**

climate requirements of archives per **material**

collection	temperatuur	relative humidity
<i>paintings, paper, wood, textile</i>	18 °C ± 2 °C	51 ± 1½ %.
<i>stone (marble, etc)</i>	18 °C ± 2 °C	51 ± 1½ %
<i>metals (silver, gold, iron, etc.)</i>	18 °C ± 2 °C	40% ± 2/3 %
<i>photography (black and white)</i>	18 °C ± 2 °C	40% ± 2/3 %

technical tools: heating, air cooling, humidification and dehumidification

museum-depot climates
per artifact material

Design CHALLENGE SUMMARY

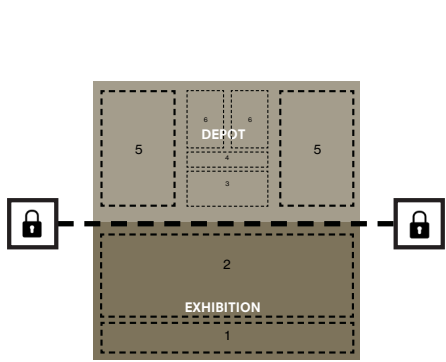

security

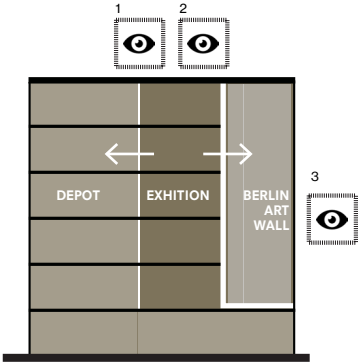

visibility

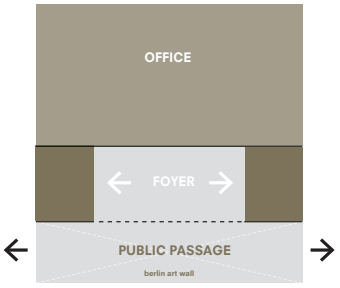

accessibility

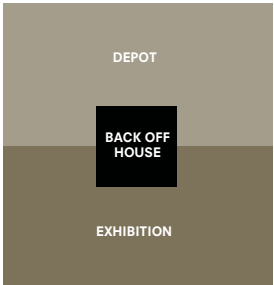

logistics

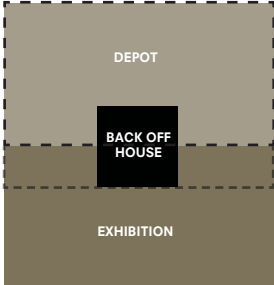

flexibility

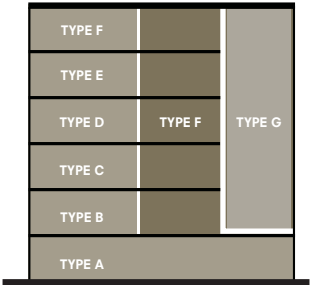

climate

1. INTRODUCTION

2. RECAP DESIGN BRIEF

3. CONCEPT

4. DESIGN

implementation

experience

adaptability

5. BUILDING TECHNOLOGY

Design
MASTERPLAN

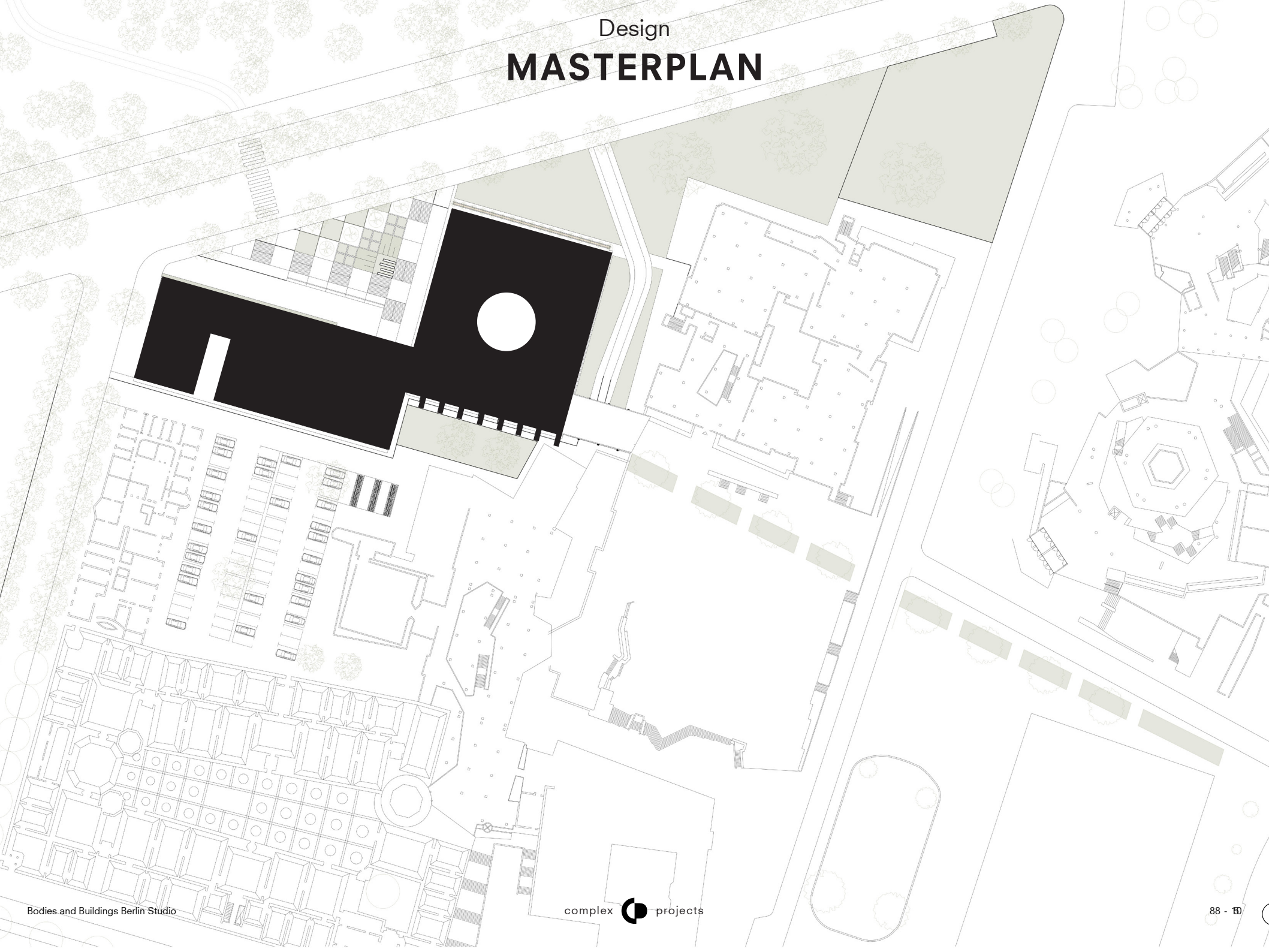





Berlin
Depot

B-E345HT

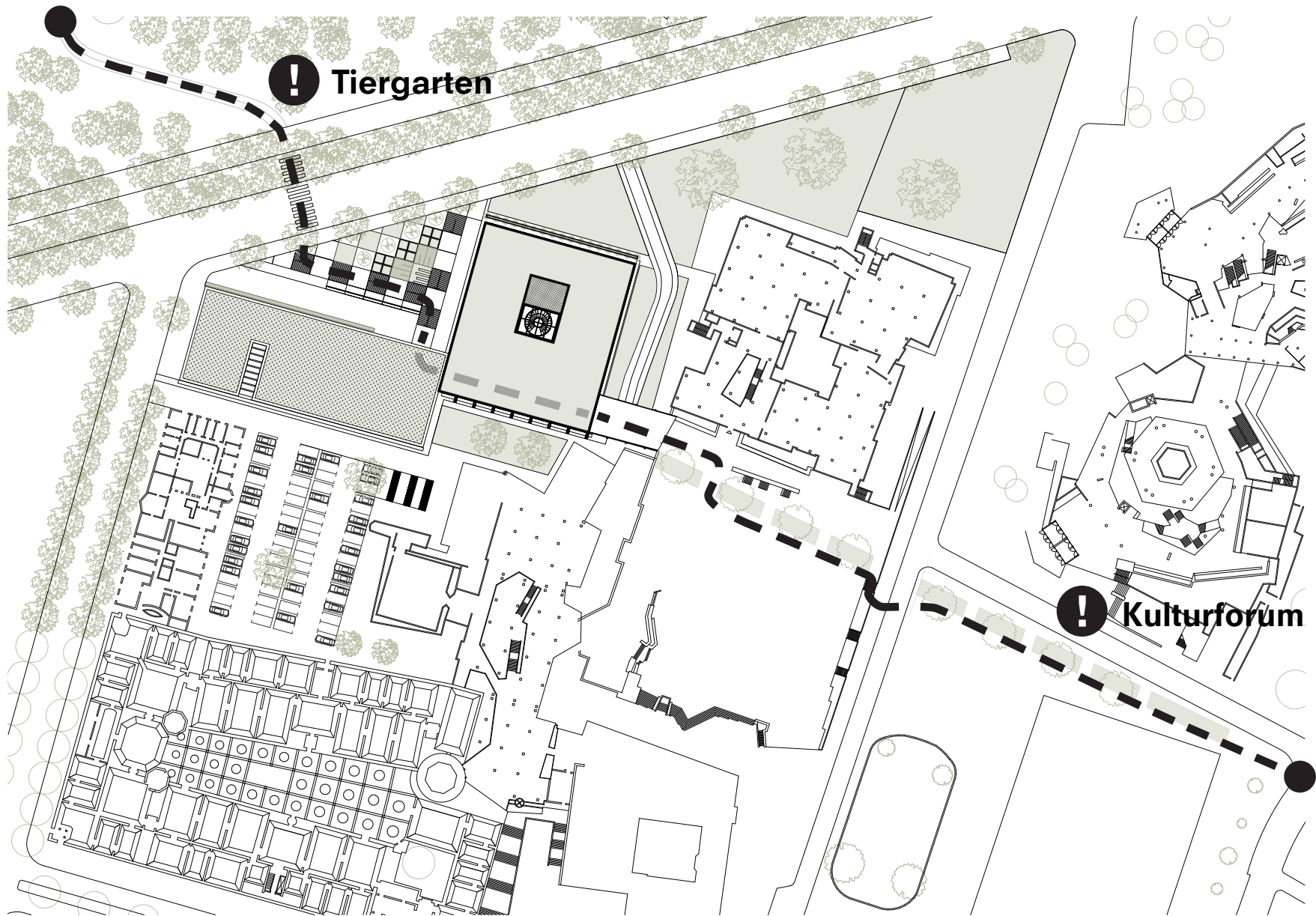
Site
GREEN CORRIDOR



Urban implementation 1:1000 
Activating the green lines of urban
vision municipality of Berlin

Site
CLEAR ROUTING

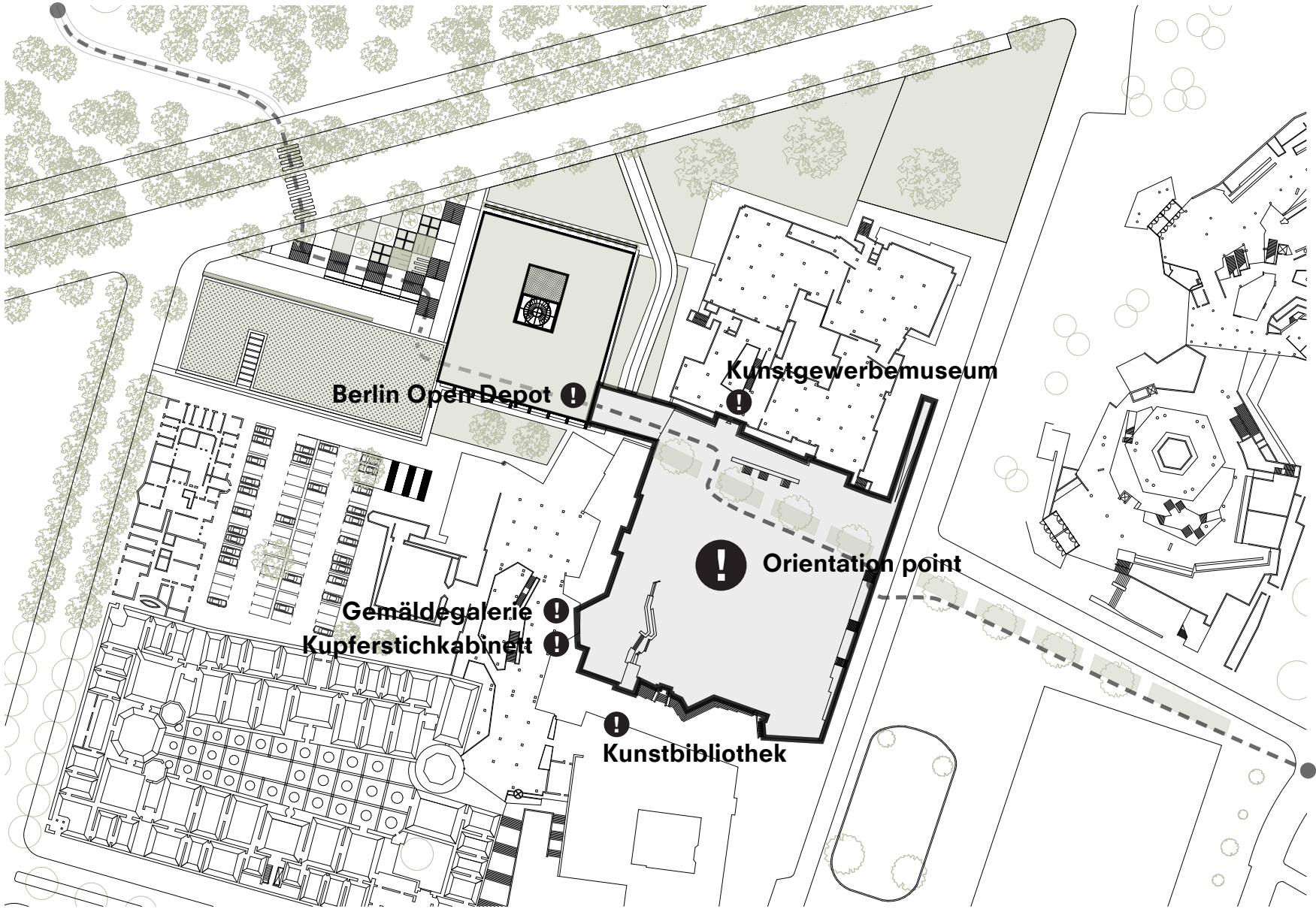

Urban implementation 1:1000 
Easy wayfinding - Entrances

Site
DOUBLE STAGE

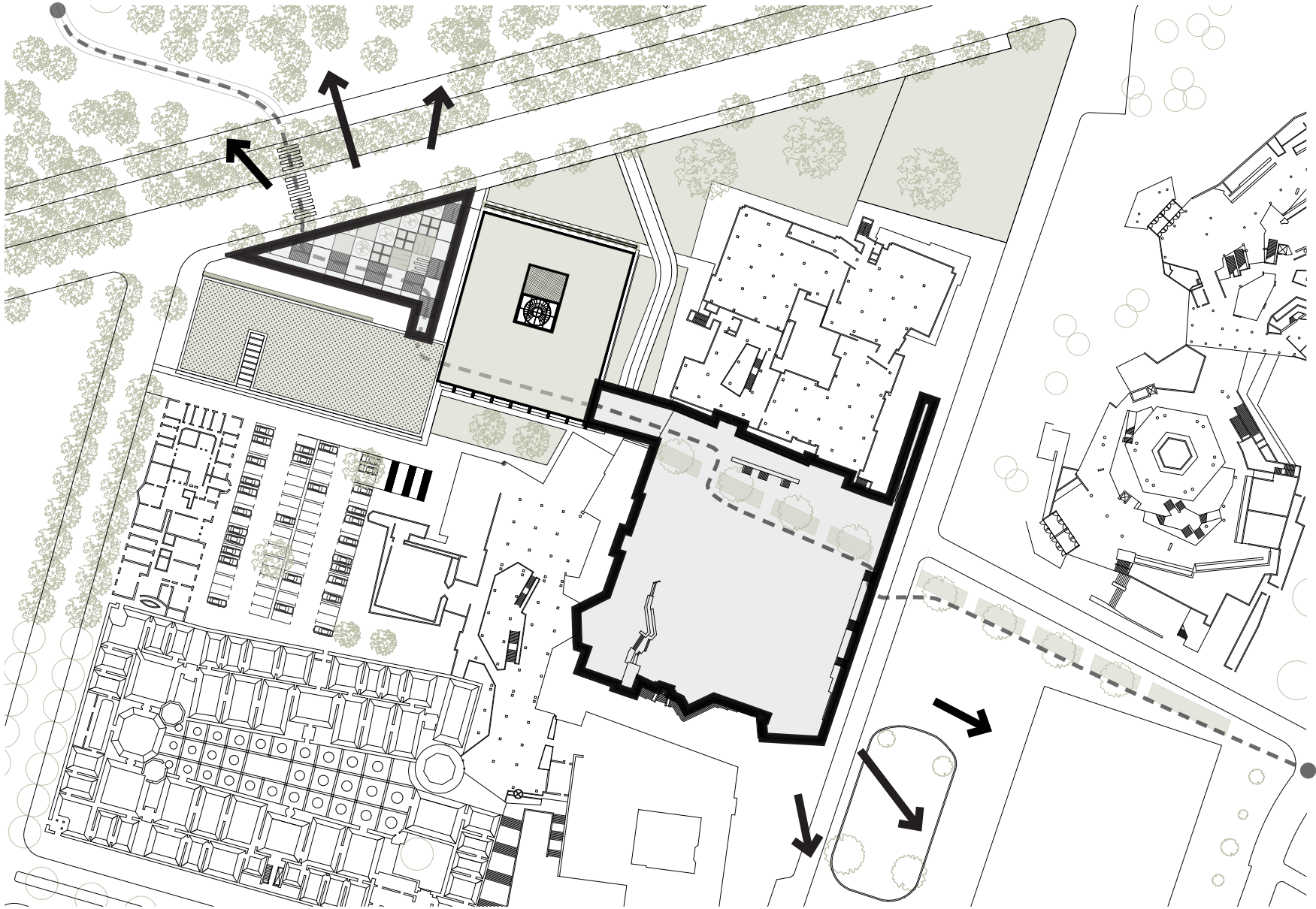

Urban implementation 1:1000 
Public spaces



Site
KULTURFORUM

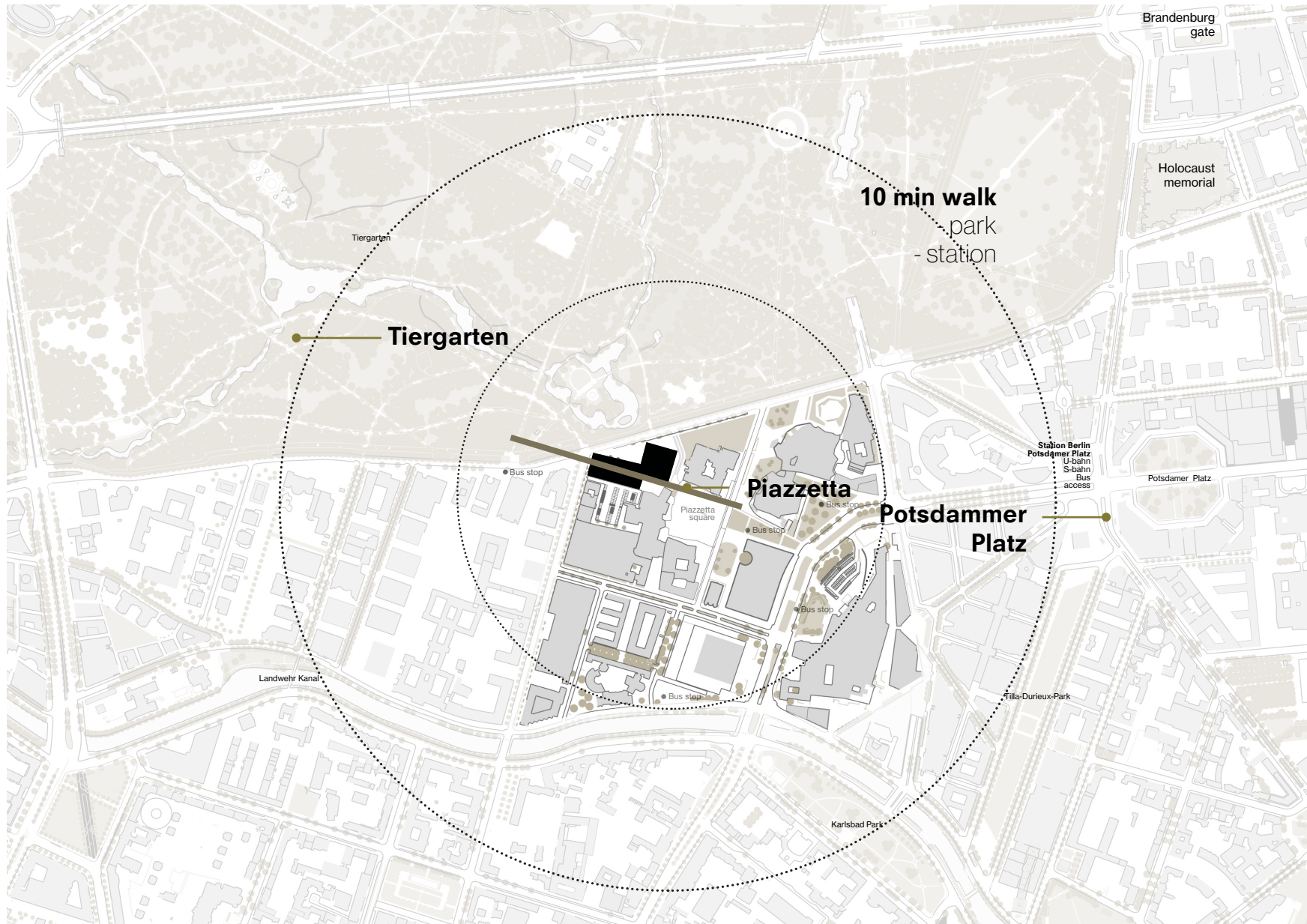

site situation - 1:5000 
Kulturforum

Design
URBAN SECTION

crossing the **height difference**
between Kulturforum and
Tiergarten

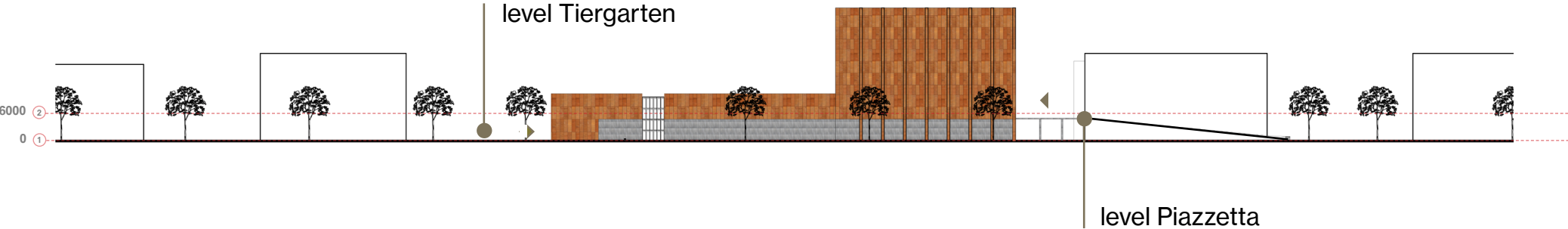

Section 1:1000
Height difference
Piazzetta and ground floor

URBAN IMPLEMENTATION

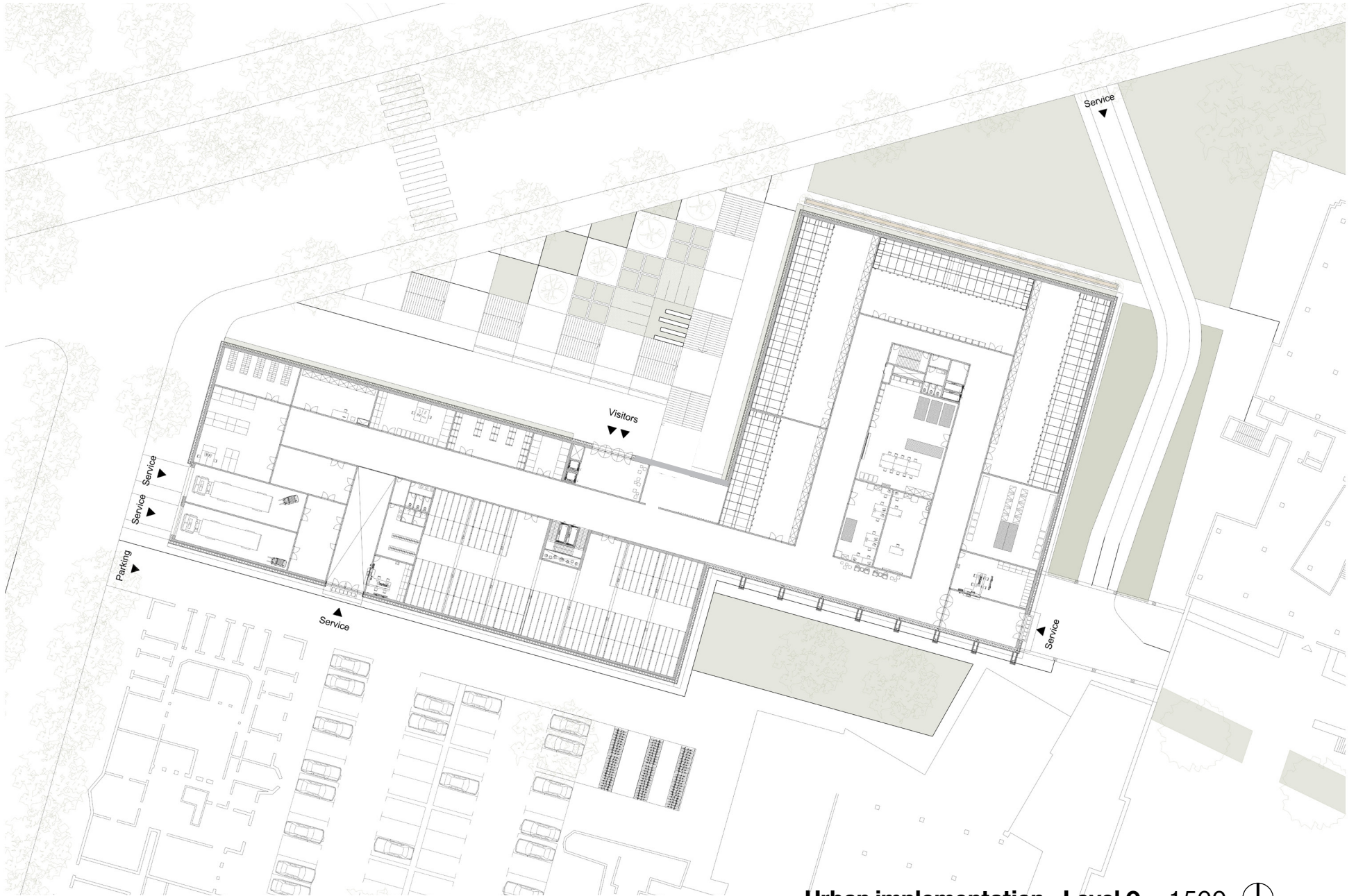

Urban implementation - Level 0
art handling, storage, restoration,
visitor entrance

1:500 

SERVICE ENTRANCE

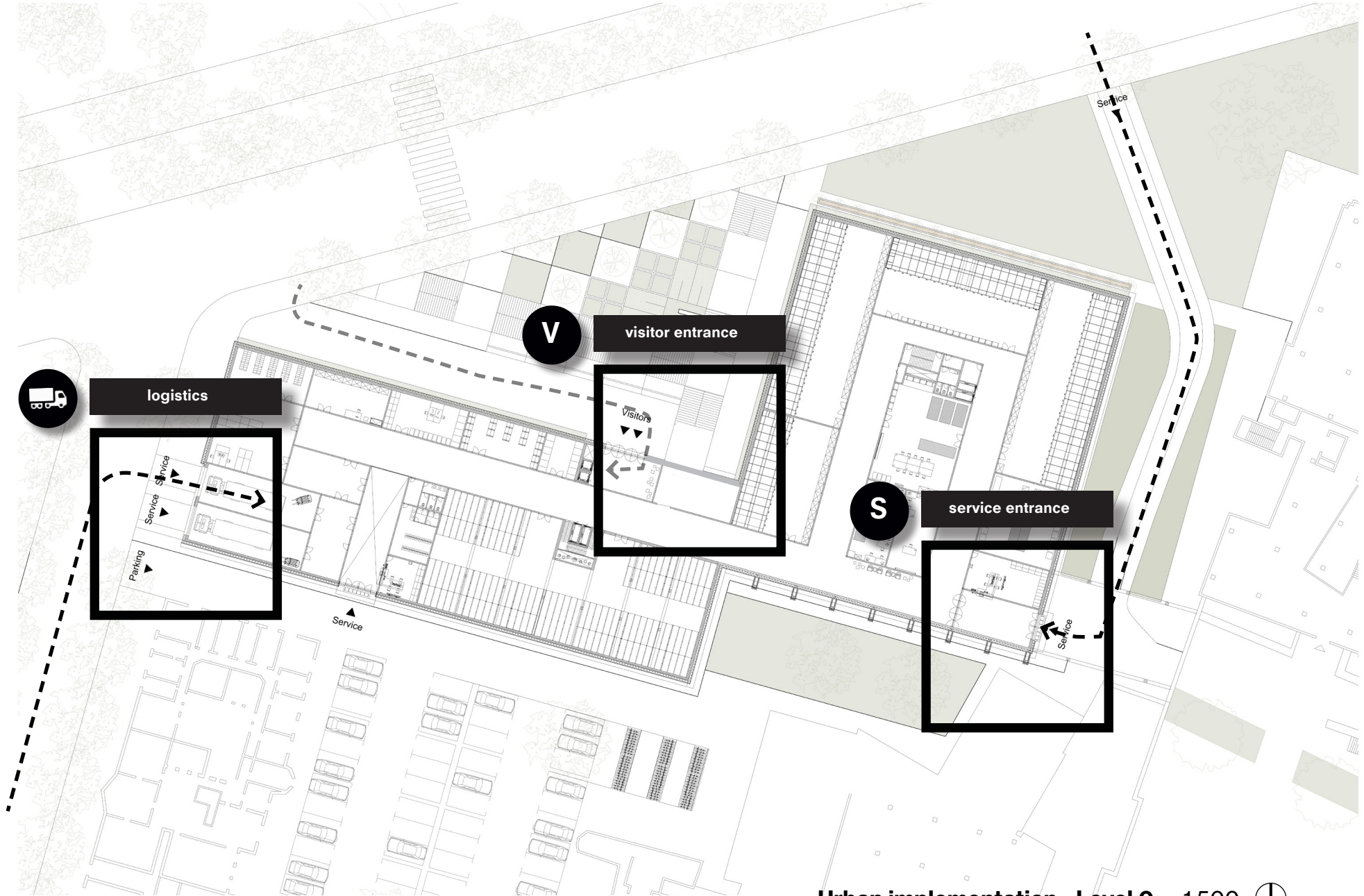

Urban implementation - Level 0
art handling, storage, restoration,
visitor entrance

1:500 

Design
LEVEL PIAZZETTA

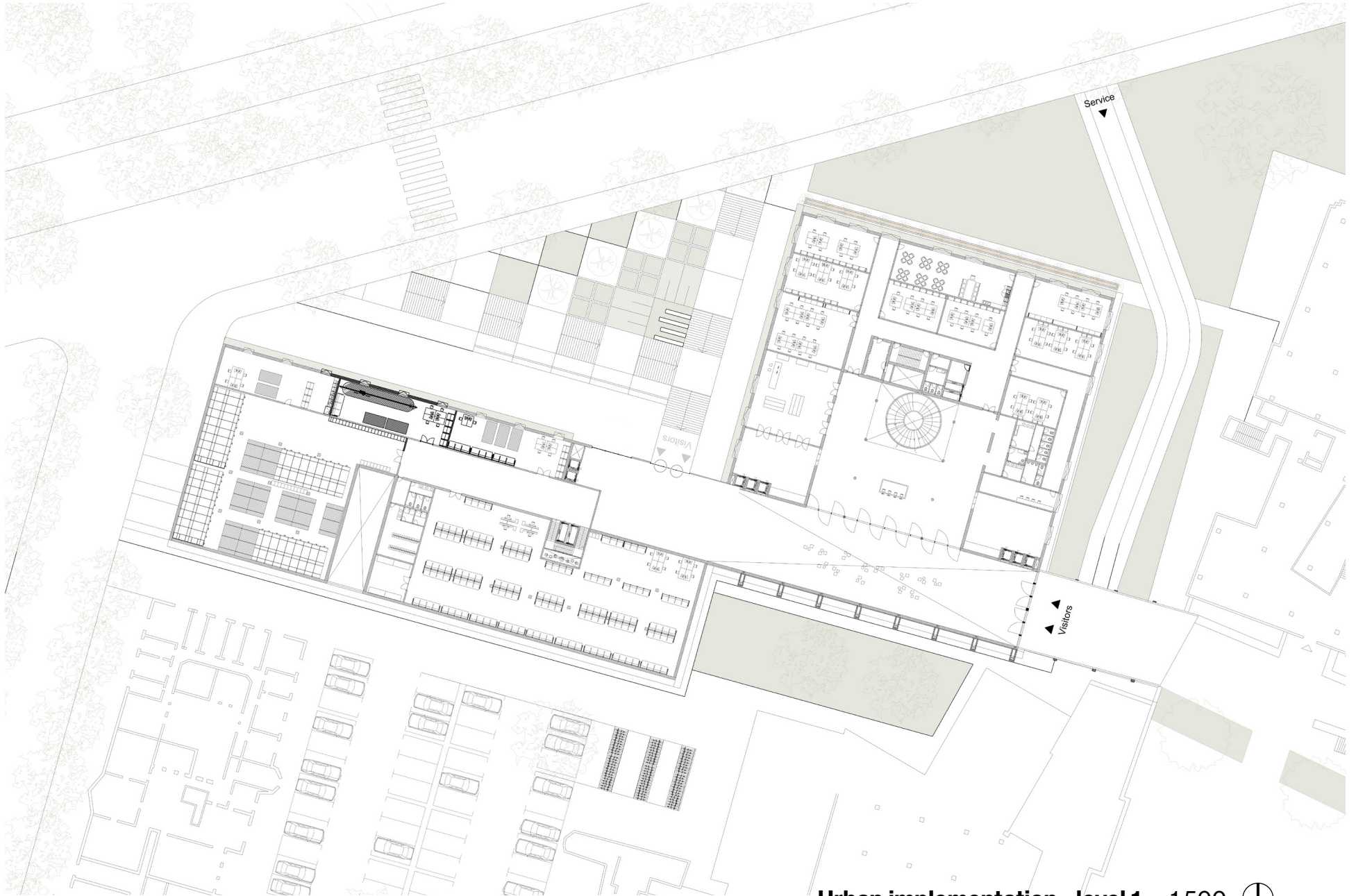

Urban implementation - level 1
foyer, info desk, cloakroom,
restoration, storage, administration

1:500



PUBLIC CORRIDOR

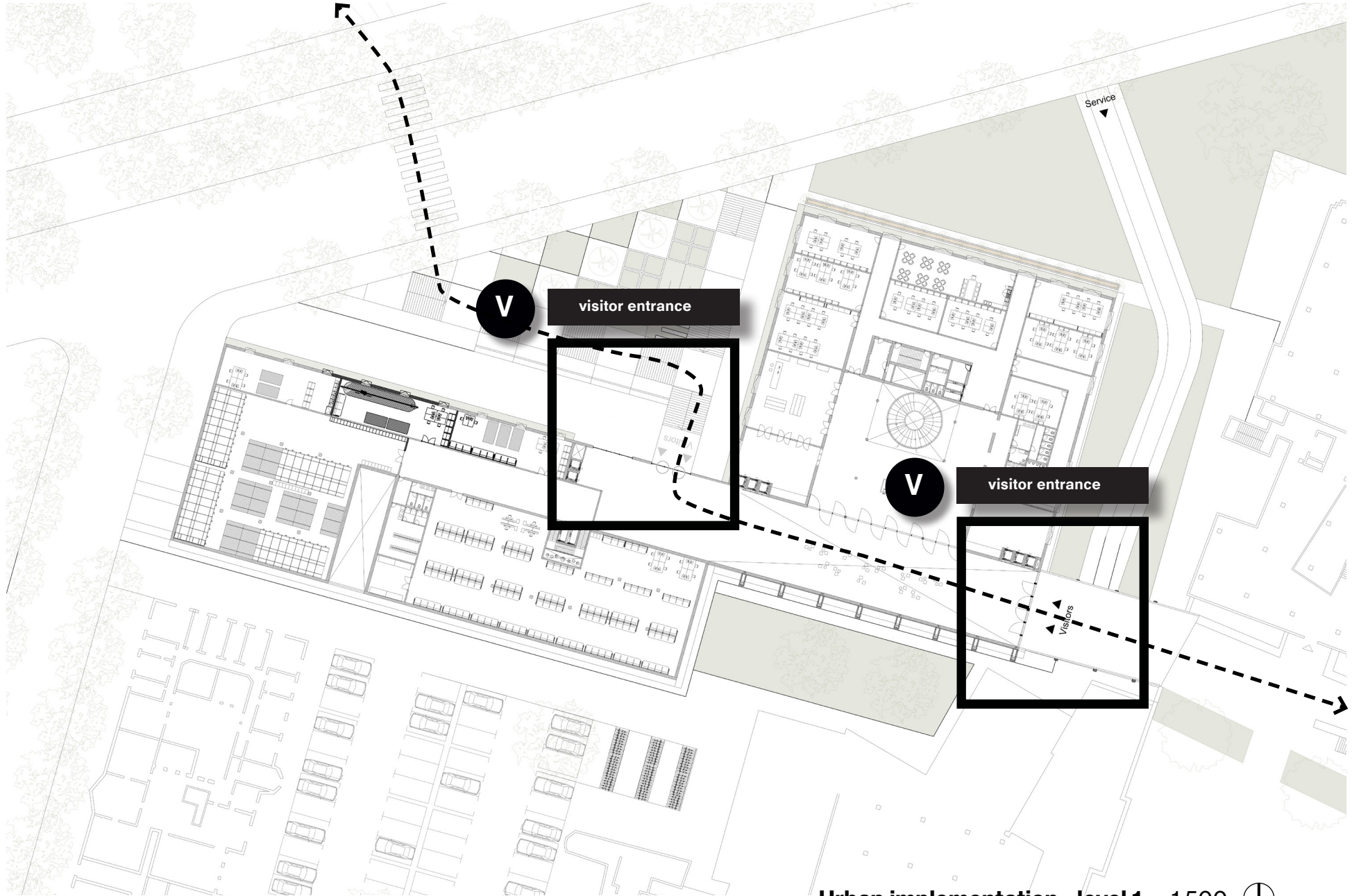

Urban implementation - level 1
foyer, info desk, cloakroom,
restoration, storage, administration

1:500





BERLIN OPEN DEPOT



Berlin
Depot

B
D



Design
BERLIN ART WALL

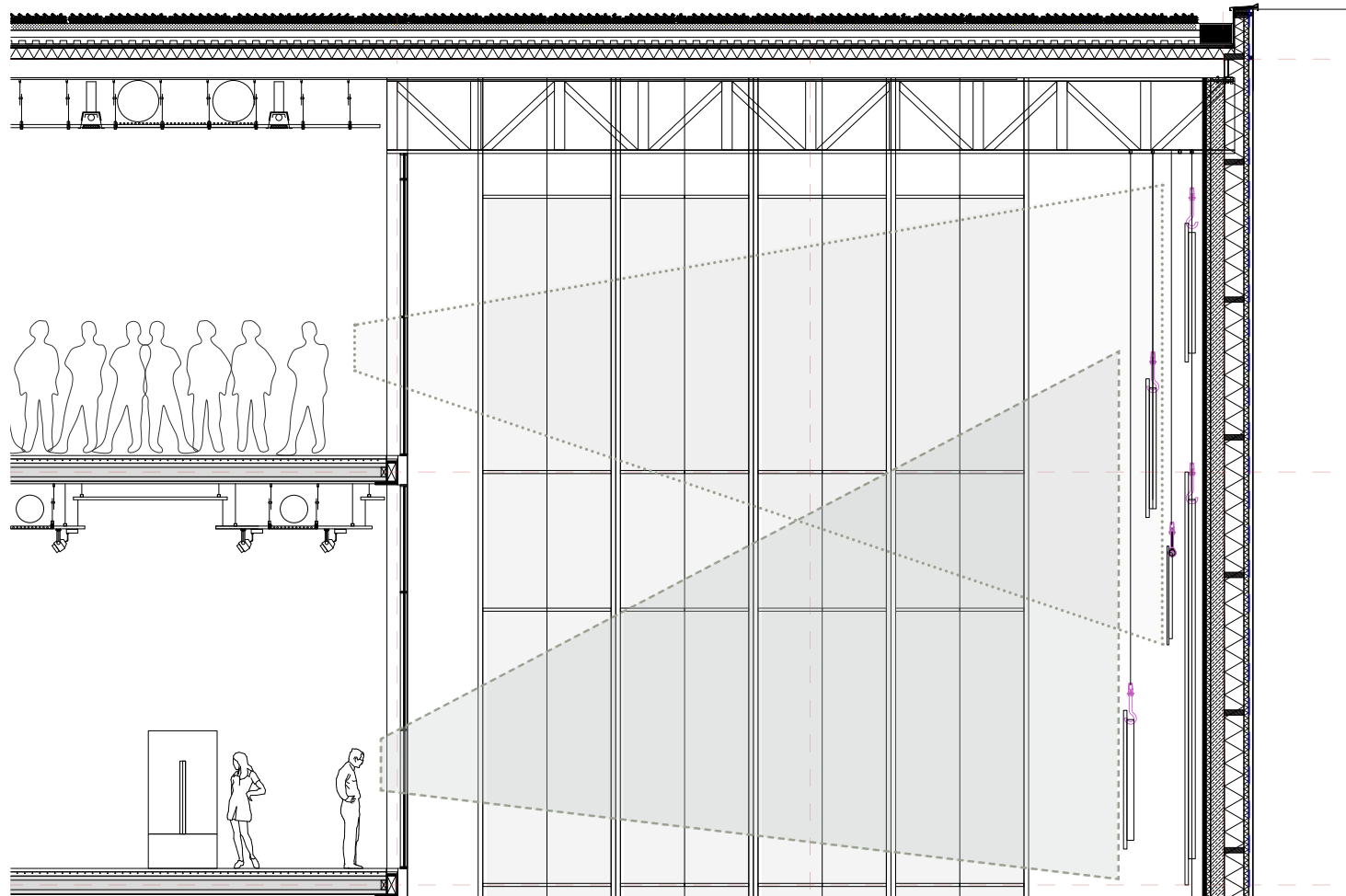

Design
BERLIN ART WALL

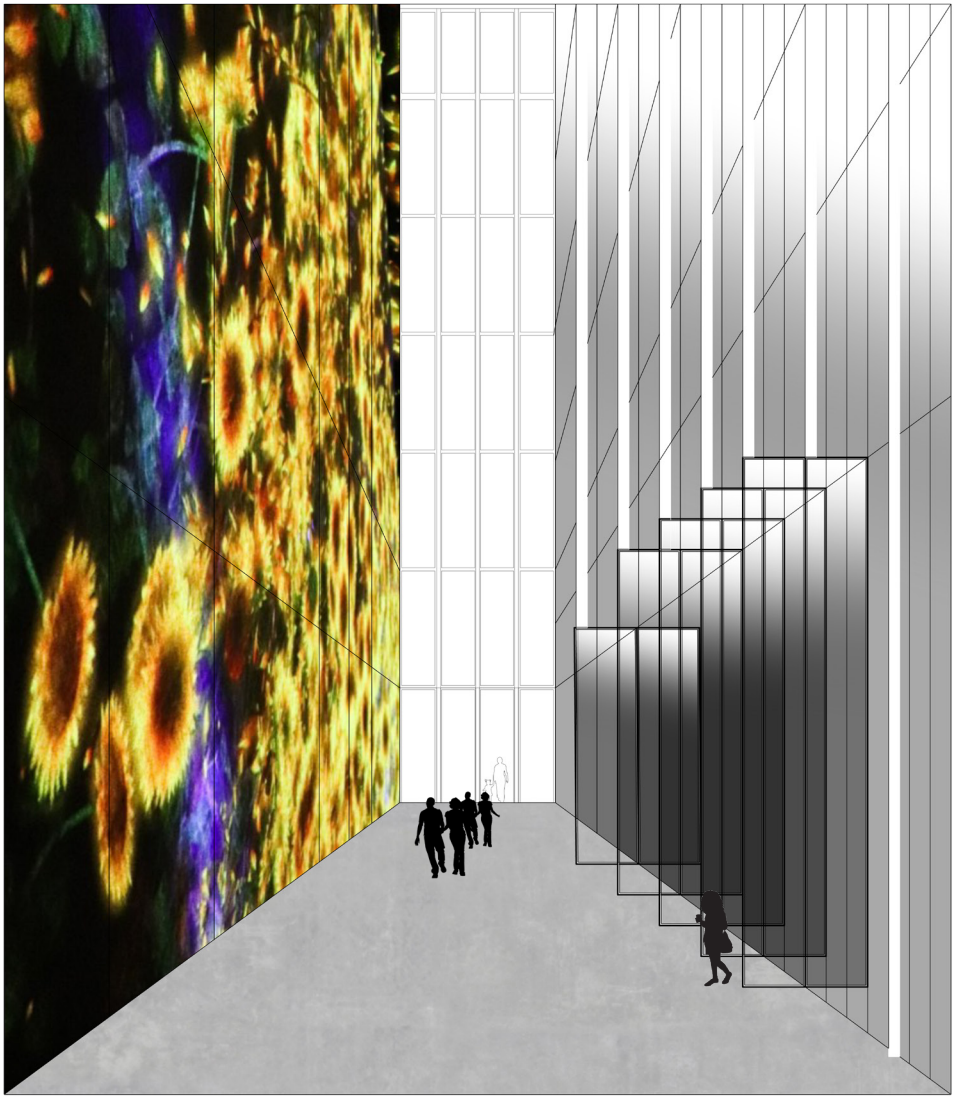

Design
DIGITAL EXHIBITIONS

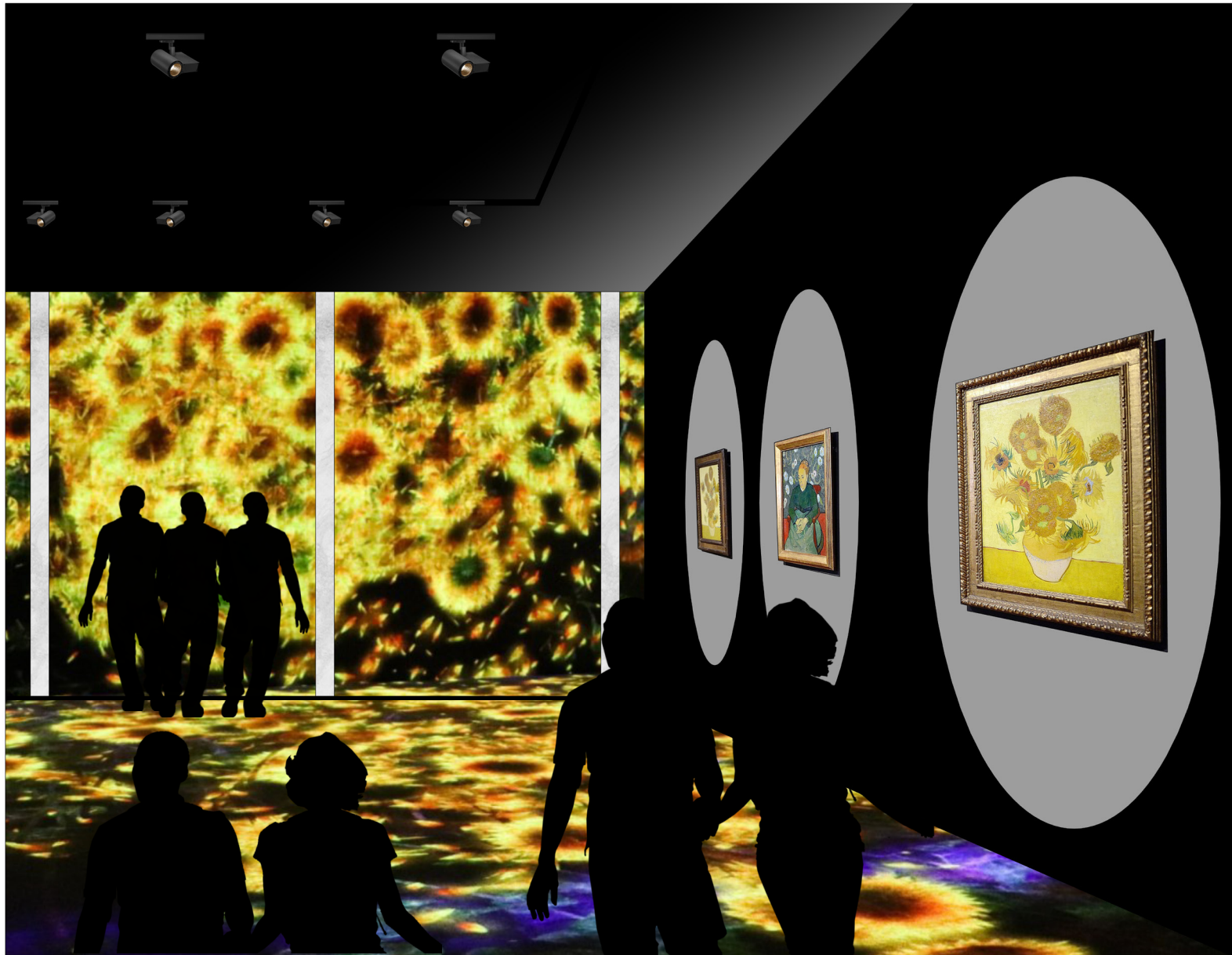

Design
TYPICAL EXHIBITIONS



Design

MULTIFUNCTIONAL EXHIBITION SPACE



Design

SIGHTLINES AND EXPERIENCE

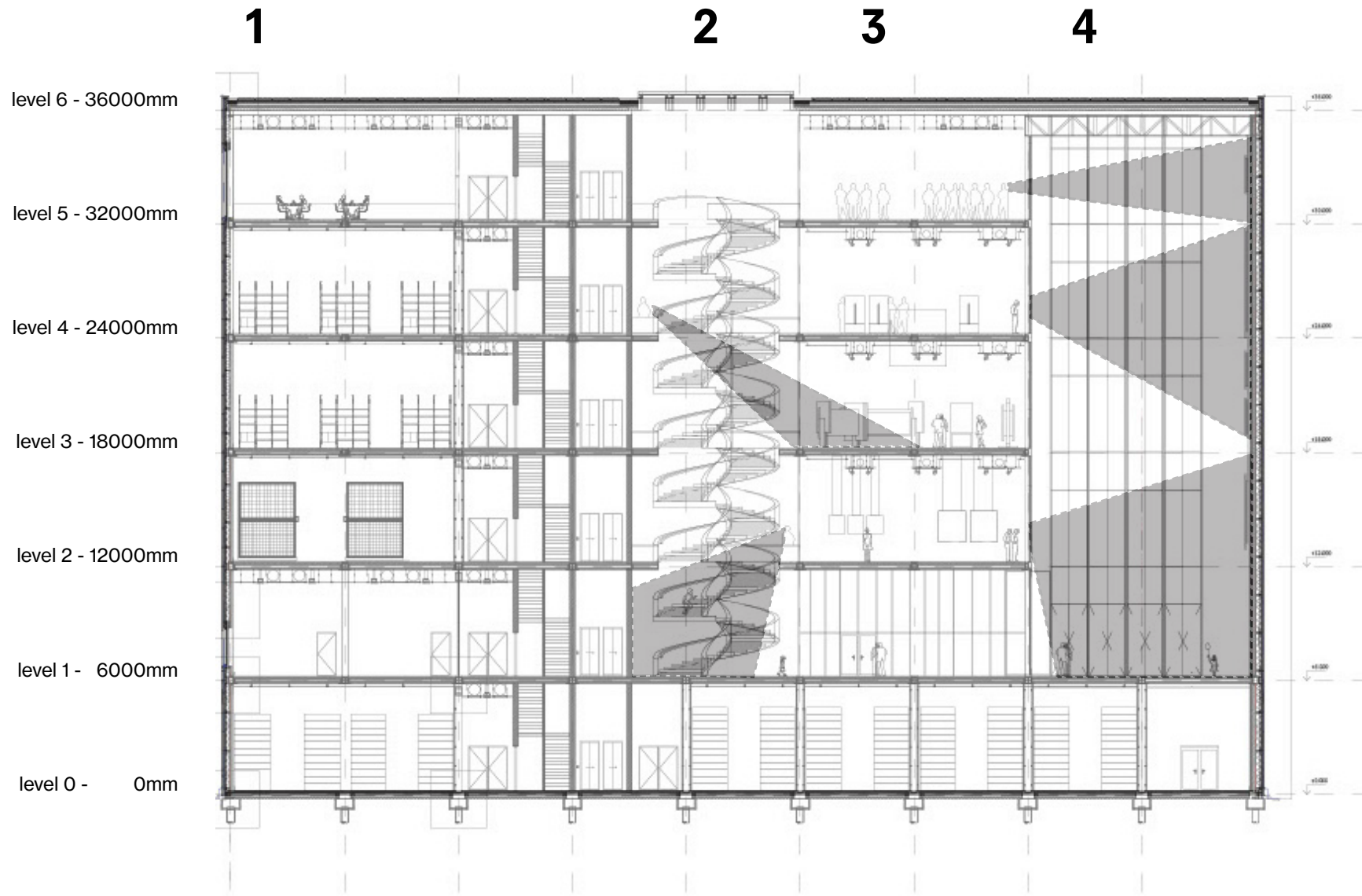

Restaurant, Stairs, Exhibition,
Berlin Art Wall,
Visitor experience 1:500

Design ROUTING

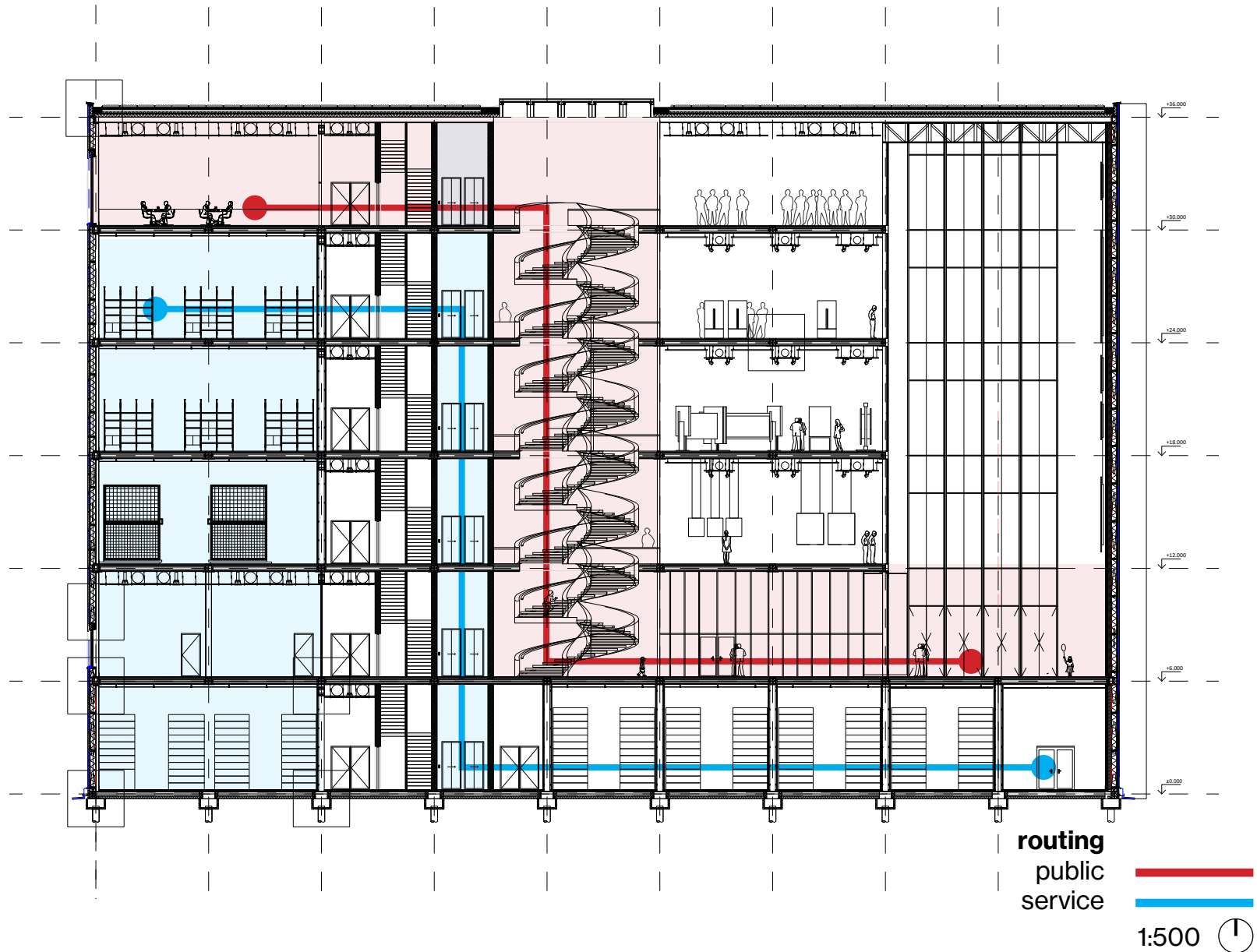





Design

SECTION DEPOT - EXHIBITION

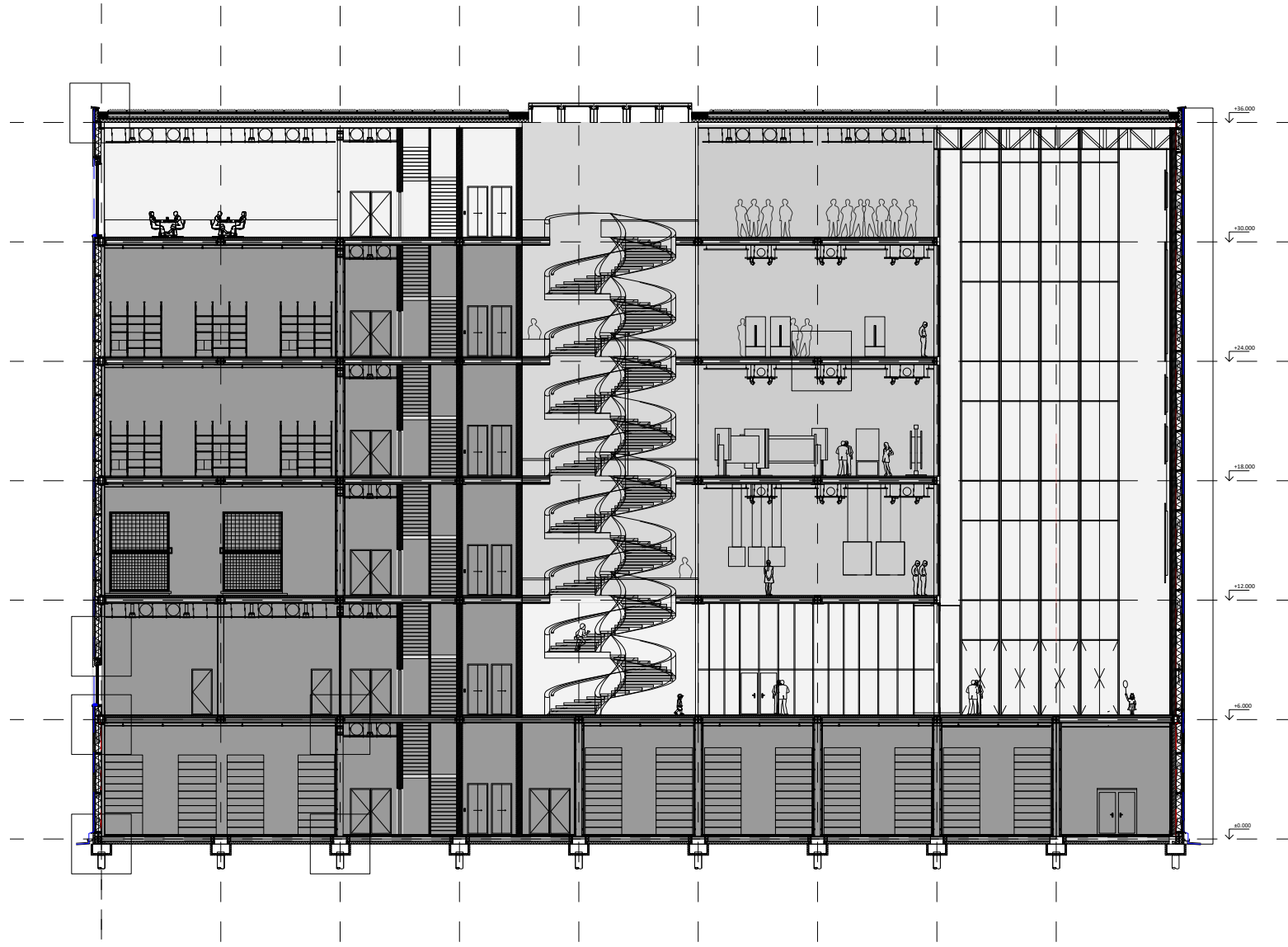

Design

DATA POINT: STORAGE SYSTEM

High density mobile systems

Defines capacity building

collection



collection: 3.600 Paintings
and framed artwork
material: canvas / wood



collection: 110.000 drawings
550.000 prints
material: canvas / papyrus

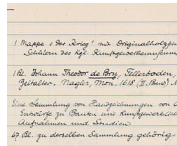

collection: 400.000 books
material: canvas / papyrus



collection: 600 costumes
900 furniture
material: textile / wood /
ivory, metals
ceramics, glass

storage system

category: large size
options: floor or ceiling rail
storage: movable racks
standard system sizes:
3m w / 3,35m h / 3,70 d

category: small size
options: height, configurable
storage: flat cabinet drawer
standard system sizes:
1,40m w / 0,45m h / 1m d

category: small size
options: height
storage: movable shelves
standard system sizes:
1,40m w / 0,45m h / 1m d

category: medium size
options: height
storage: movable shelves
standard system sizes:
2,40m w / 2 m h / 1,20m d

storage system

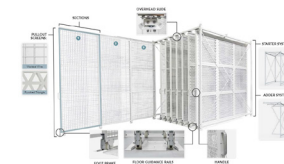

Design Brief

STORAGE SYSTEM DIMENSIONS

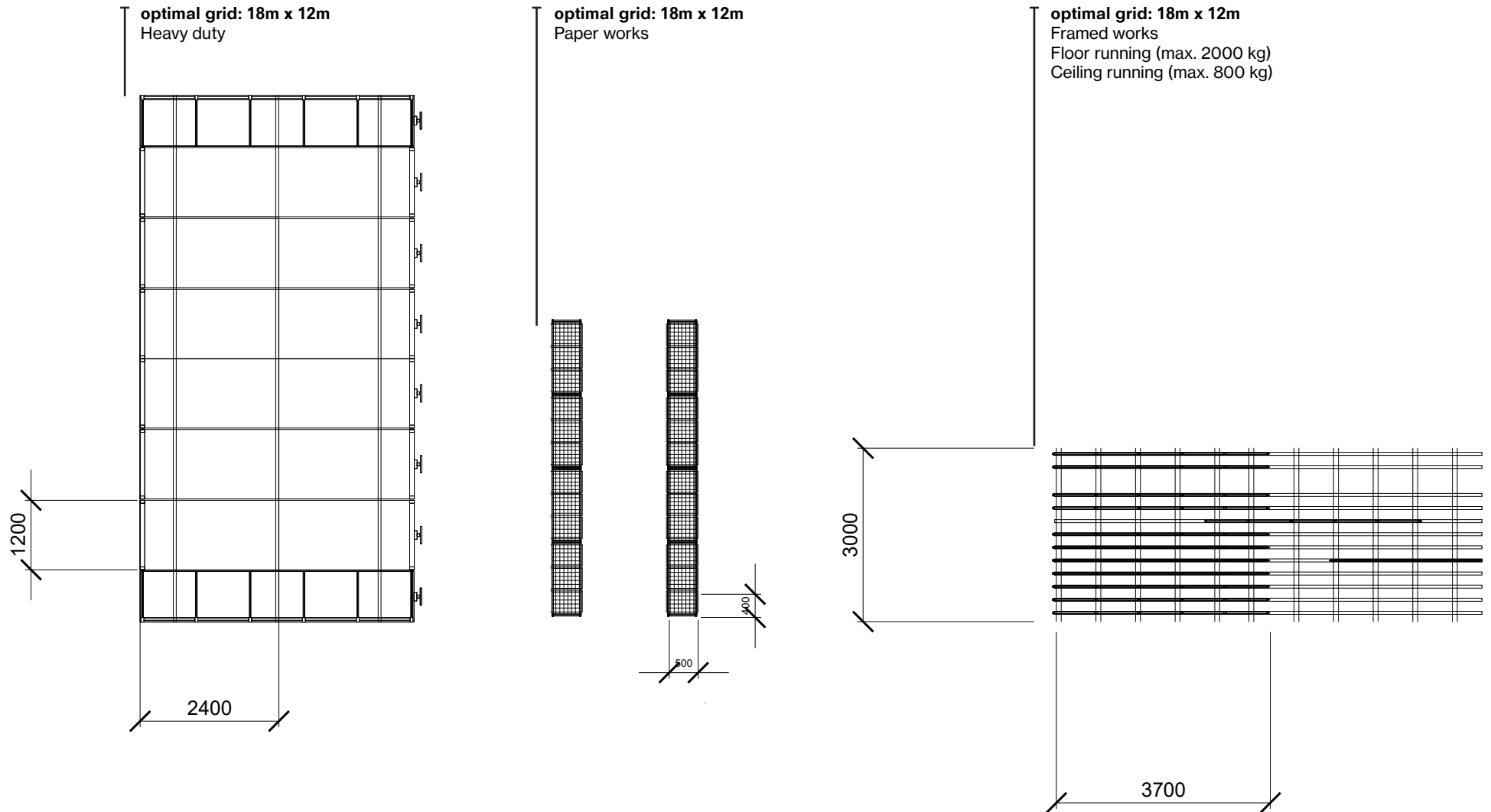

Design Brief

STORAGE SYSTEM **OPTIMAL GRID**

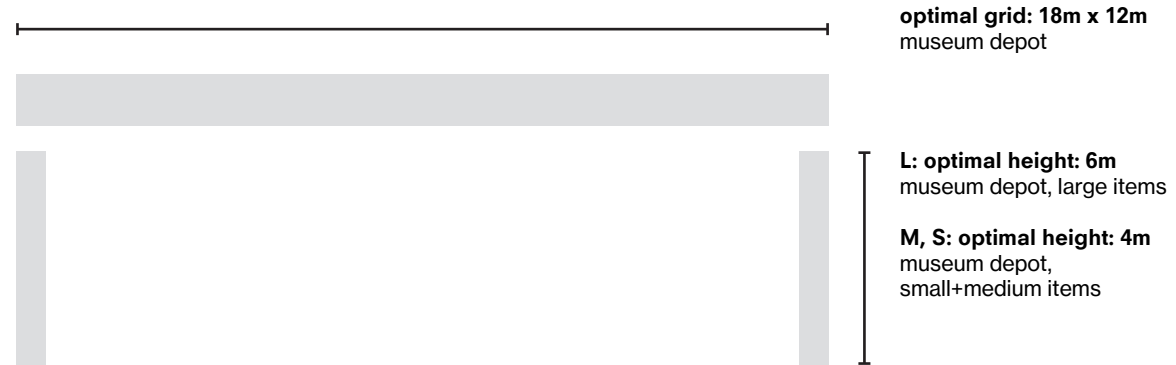

Grid + High density mobile systems
provide flexibility

Ceiling height density mobile systems
provide flexibility

Design
STORAGE GRID

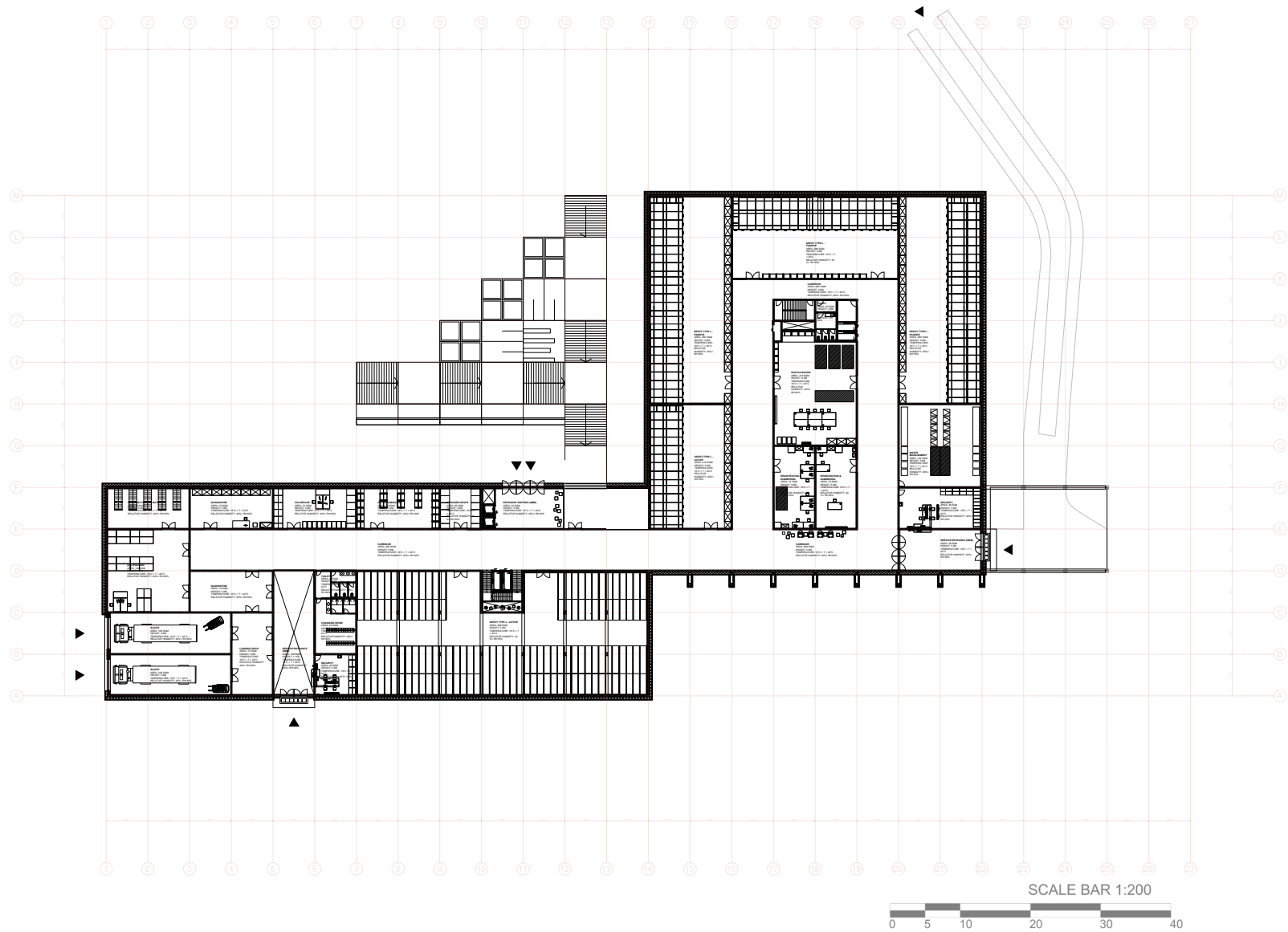

Plan ground floor - Level 0
Art handling, (un-)packing,
registration, depot type L



Design ADAPTABILITY

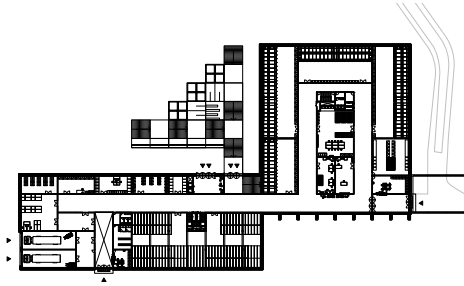

GF00

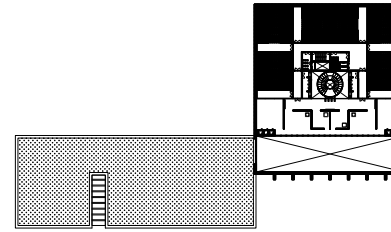

L02 - B

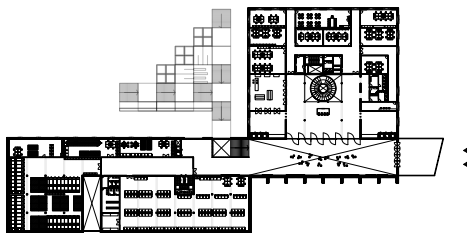

L01

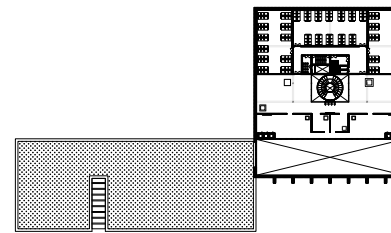

L03 - A

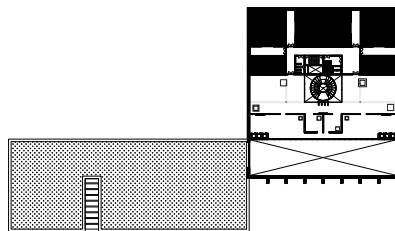

L02 - A

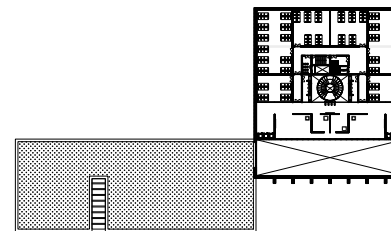

L03 - B

Design
LEVEL 0 TIERGARTEN

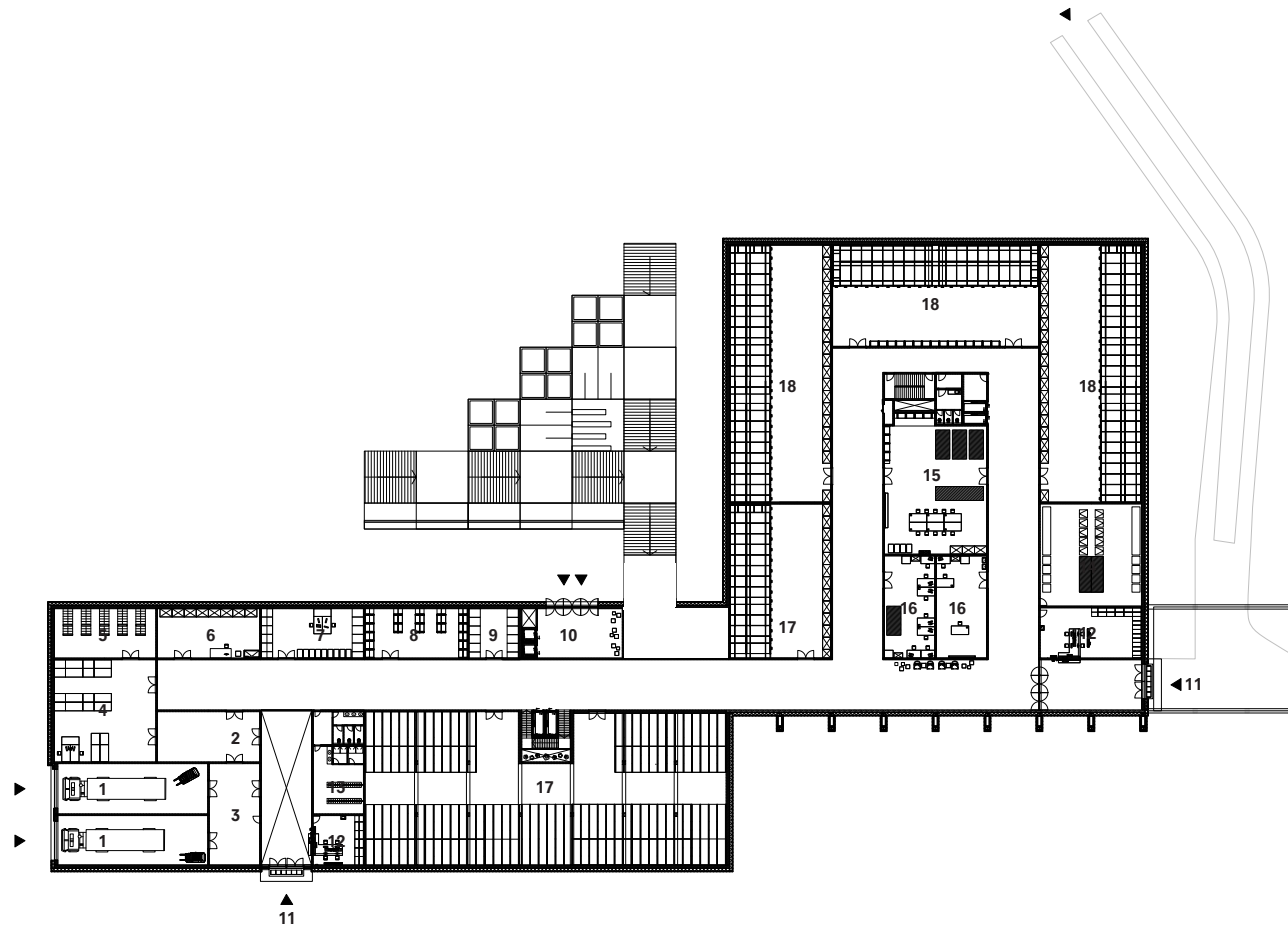

Legend

- 1. Sluice
- 2. Loading deck
- 3. Protocol space
- 4. Packaging space
- 5. Packaging material storage
- 6. Quarantine
- 7. Coldspace
- 8. Decontamination / cleaning
- 9. Nitrogen space
- 10. Visitor entrance
- 11. Service entrance
- 12. Security
- 13. Changing room
- 14. Cleaning, waste management
- 15. Registration & numbering
- 16. Photo atelier & digitalisation
- 17. Depot - Type L, active
- 18. Depot - Type L, passive



floorplan - level 0
 depot, registration,
 art- & service entrance



LEVEL 1 PIAZZETTA

Legend

- 19. Public indoor street
- 20. Foyer
- 21. Infodesk, ticketing, audiotour
- 22. Wardrobe & lockers
- 23. Toilets
- 24. Museumshop
- 25. Administration
- 26. Canteen
- 27. Changing room
- 28. Restauration studio
- 29. Depot - Type L, heavy duty
- 30. Depot - Type M
- 31. Technical space

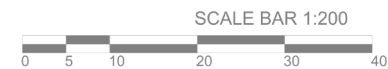
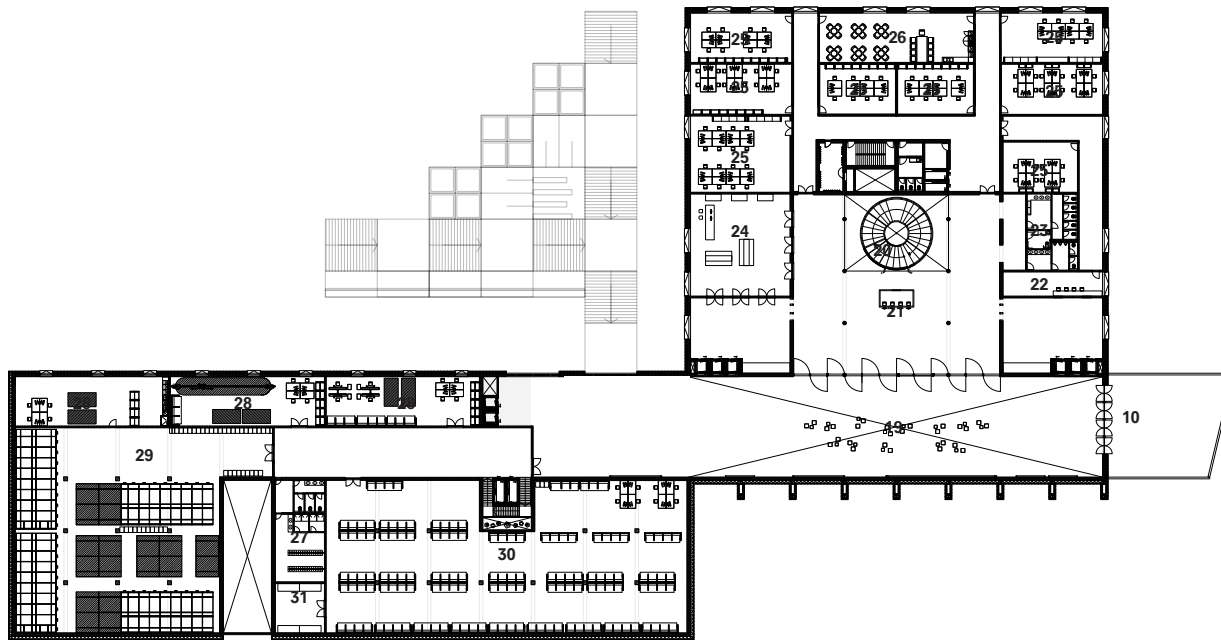

floorplan - level 1
 public entrance, administration,
 restoration, storage



Design

LEVEL 2 **TYPE M**

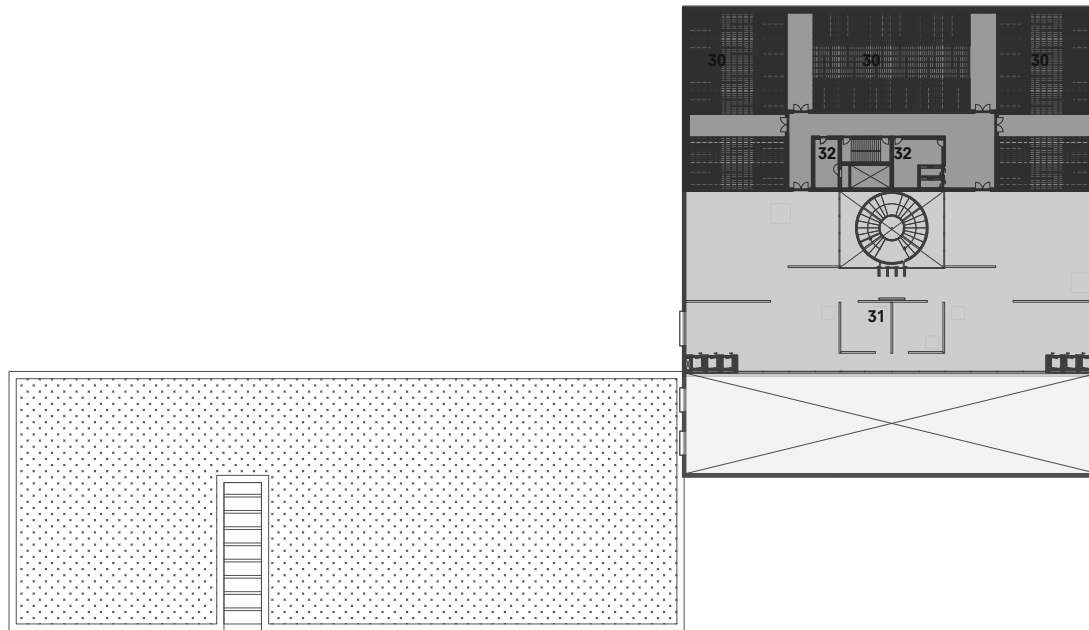

Legend

- 30. Depot - Type M
- 31. Exhibition space
- 32. Storage Exhibition space

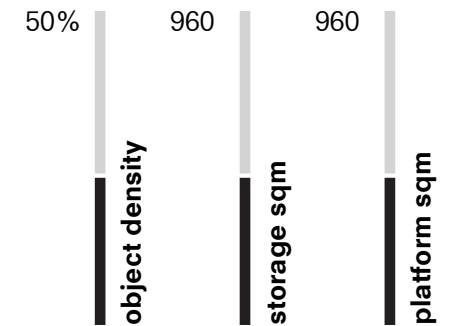

floorplan - level 2 1:500 
 depot, exhibition space,
 service block

Design

LEVEL 2 **TYPE M**

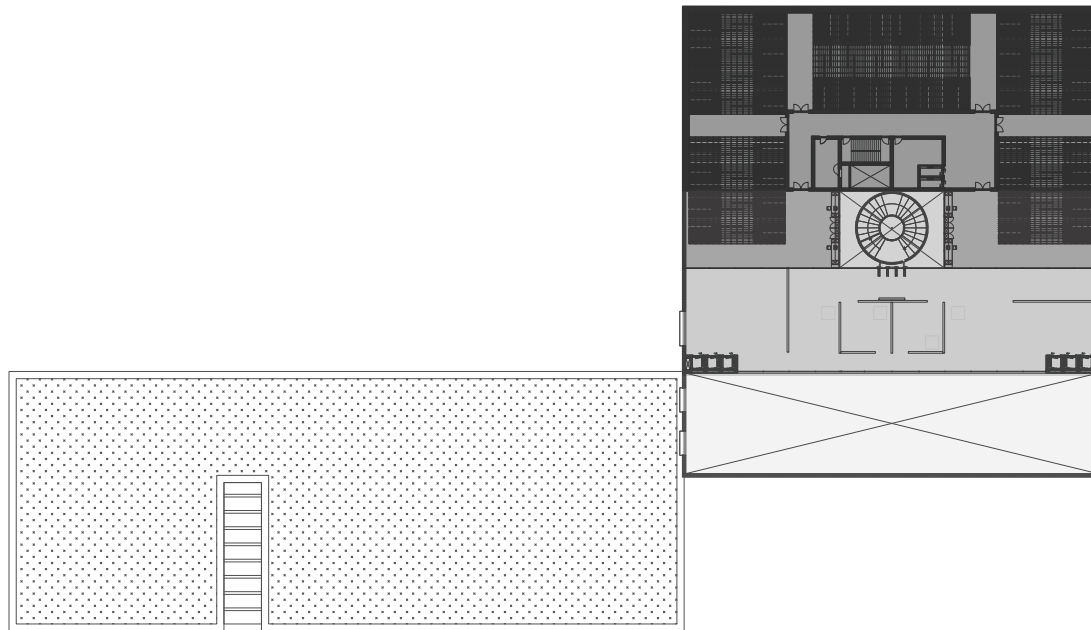

Legend

- 30. Depot - Type M
- 31. Exhibition space
- 32. Storage Exhibition space

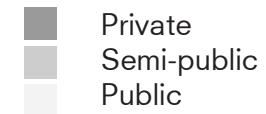
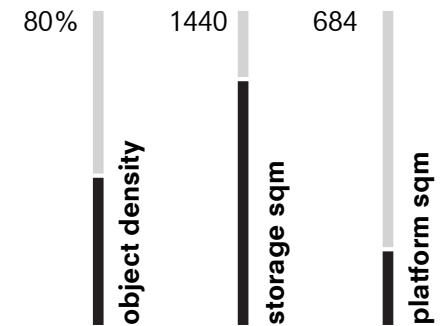

floorplan - level 2 1:500 
 depot, exhibition space,
 service block

Design

LEVEL 3 TYPE S

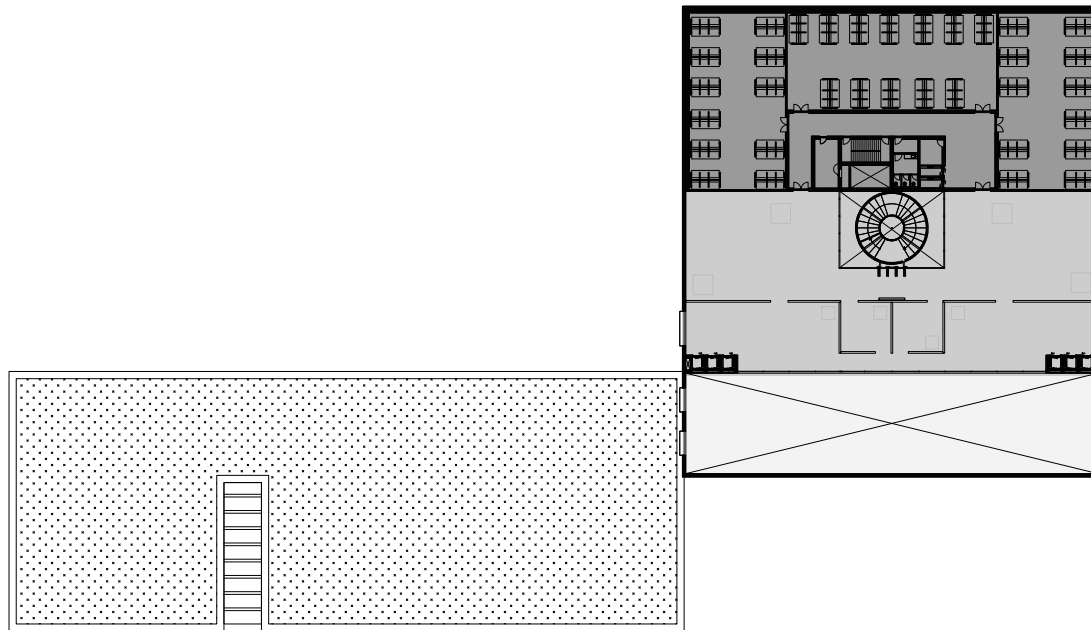

Legend

- 30. Depot - Type S
- 31. Exhibition space
- 32. Storage Exhibition space

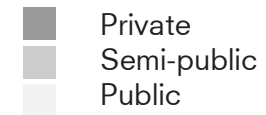
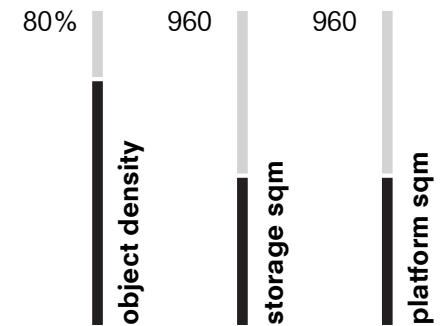

floorplan - level 3 1:500 
 depot, exhibition space,
 service block

Design

LEVEL 3 TYPE S

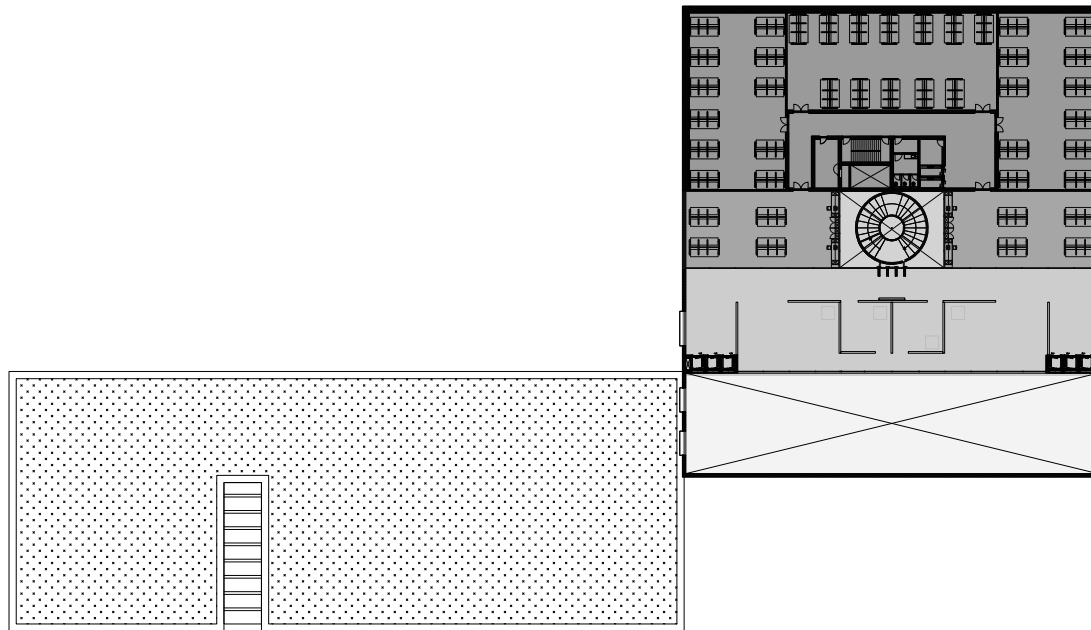

Legend

- 30. Depot - Type S
- 31. Exhibition space
- 32. Storage Exhibition space

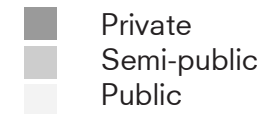
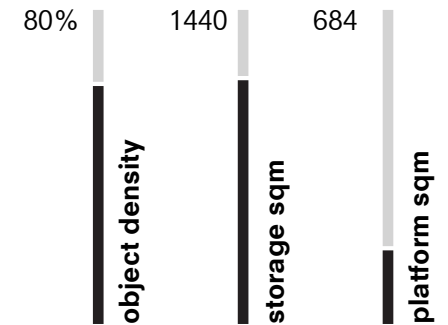

floorplan - level 3 1:500 
 depot, exhibition space,
 service block

Design

LEVEL 3 TYPE S

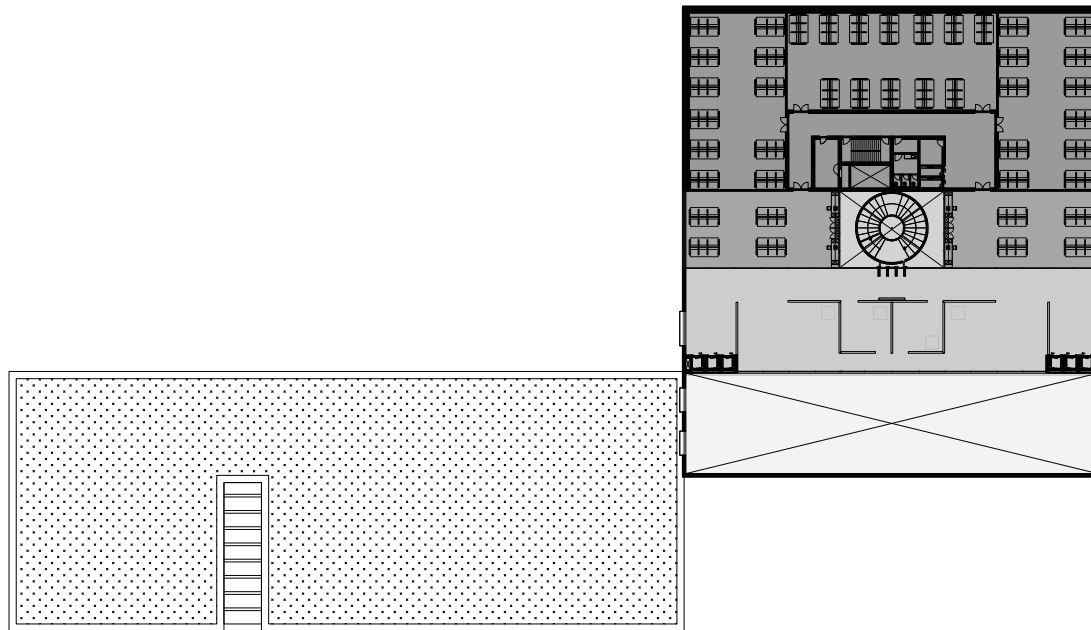

Legend

- 30. Depot - Type S
- 31. Exhibition space
- 32. Storage Exhibition space

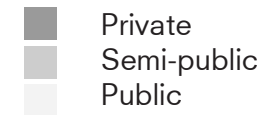
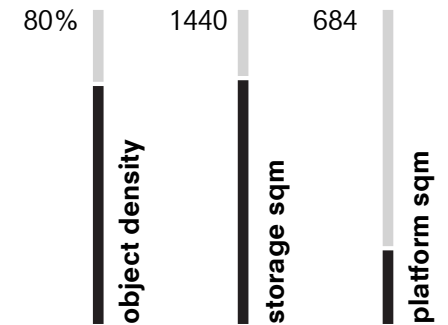

floorplan - level 3 1:500 

depot, exhibition space,
service block

Design

DENSIFICATION

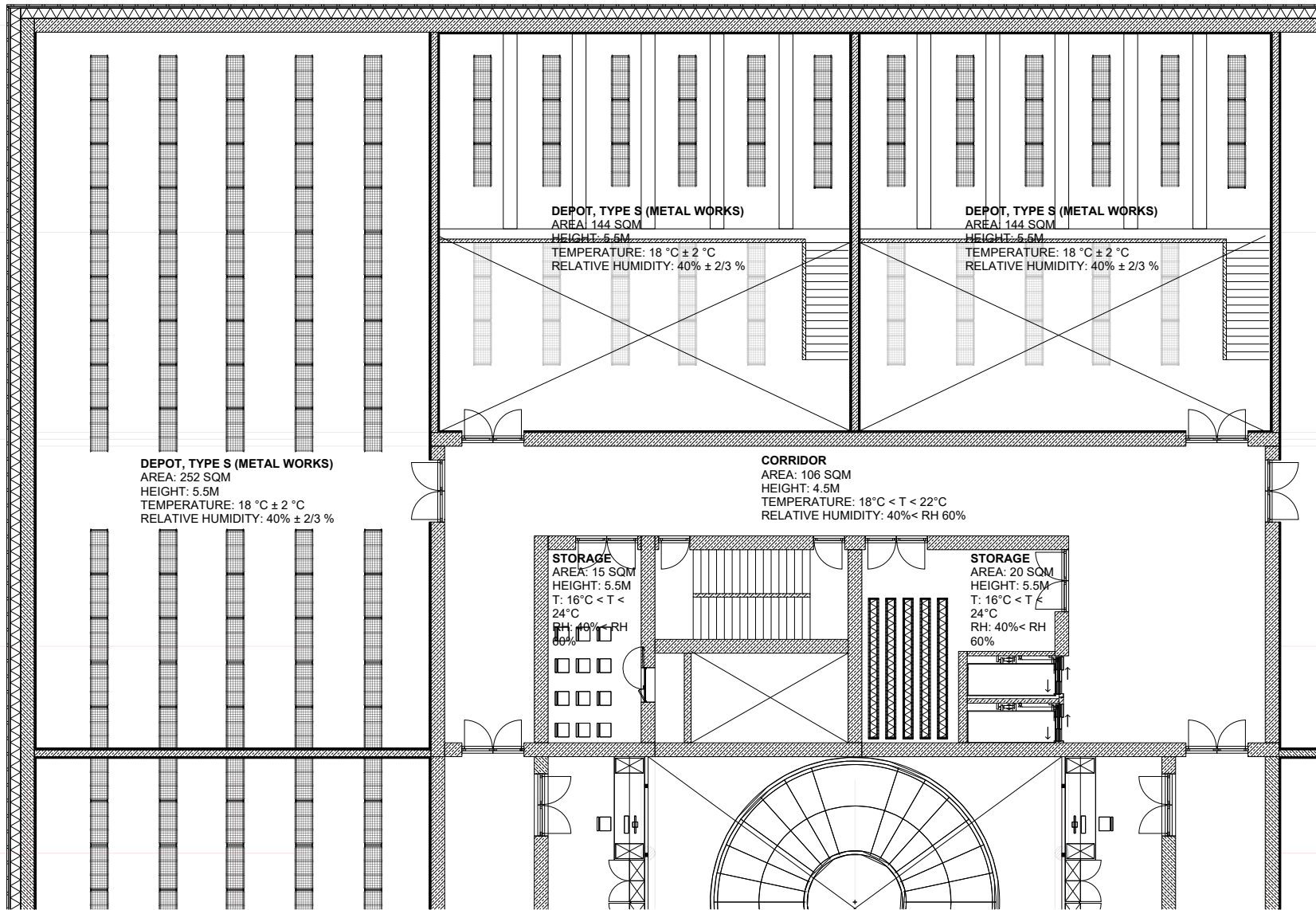

STORAGE: S, M, L SPACE

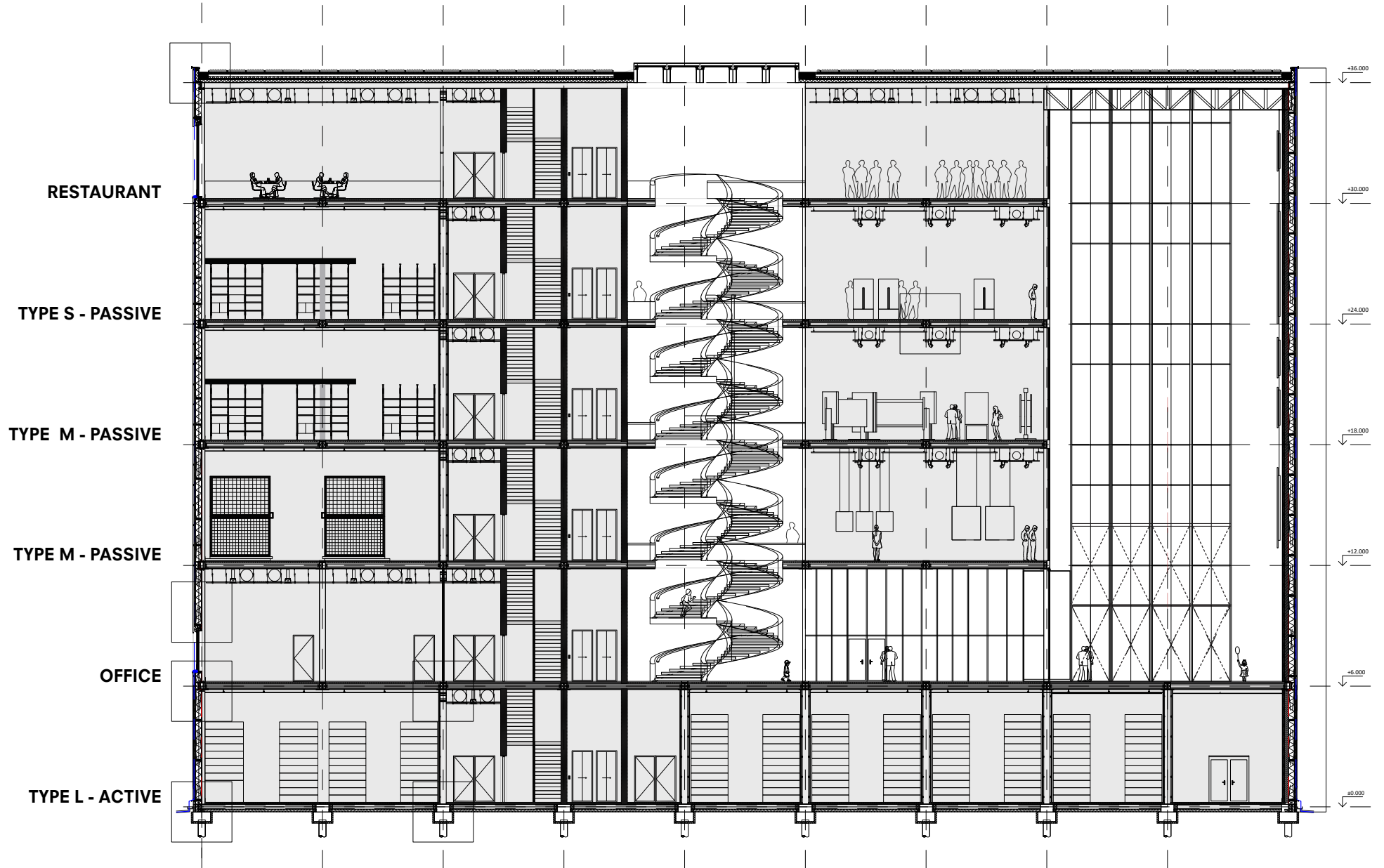

Design
SECTION TYPE S, M, L

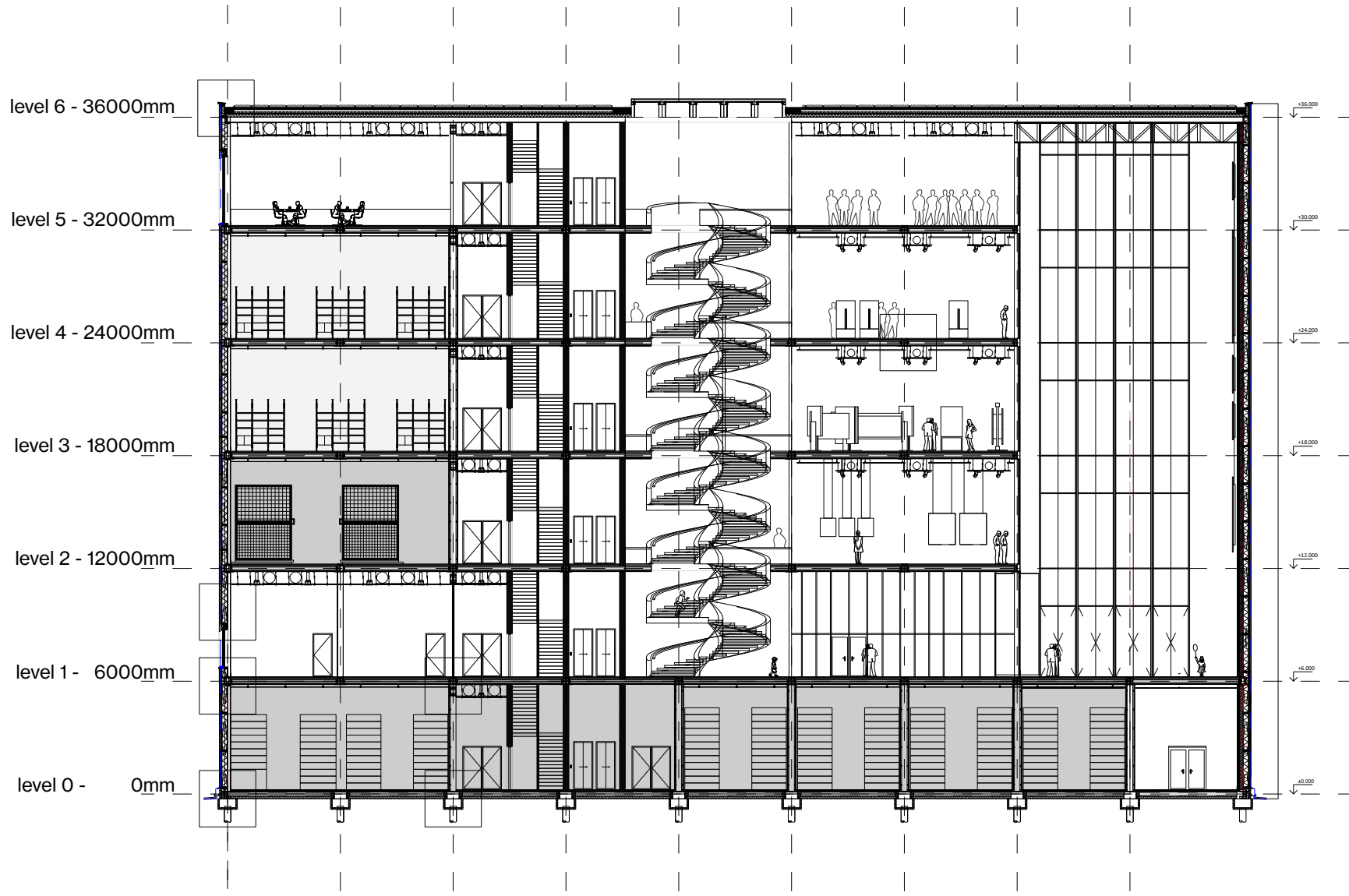

Zones per material 1:500
Object

Design
EAST FAÇADE

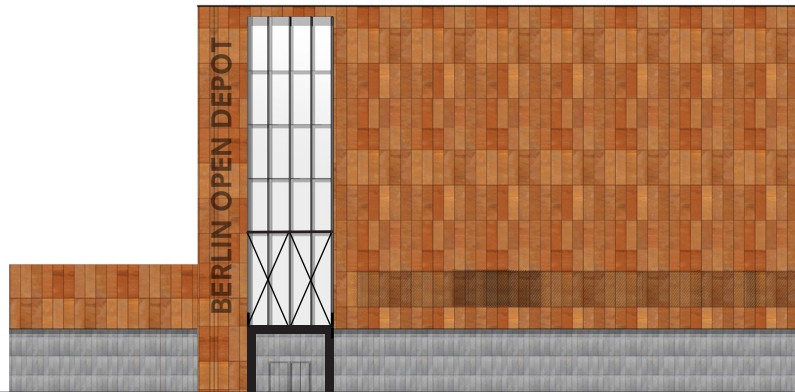

Design
WEST FAÇADE

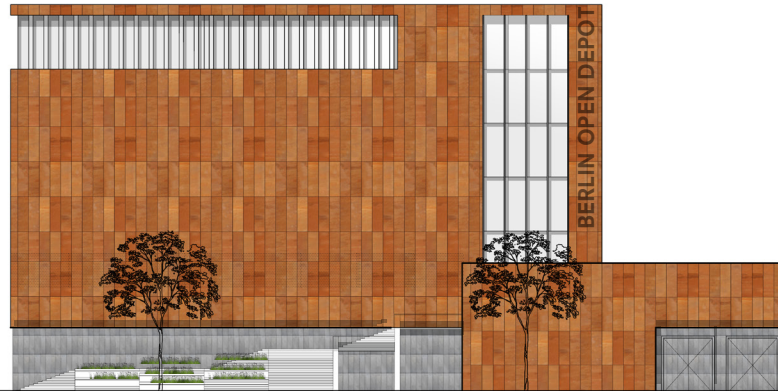

Design
NORTH FAÇADE





Design
SOUTH FAÇADE

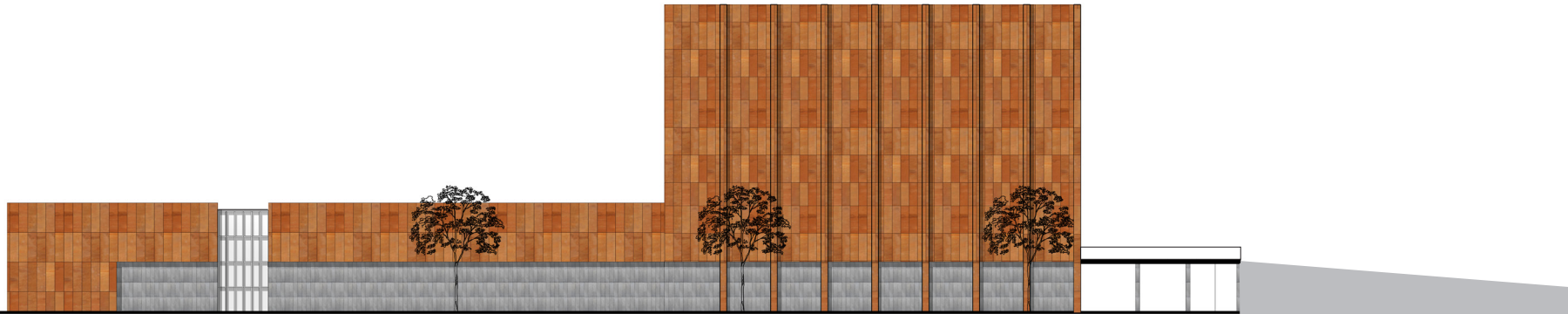

Building
WEST ELEVATION

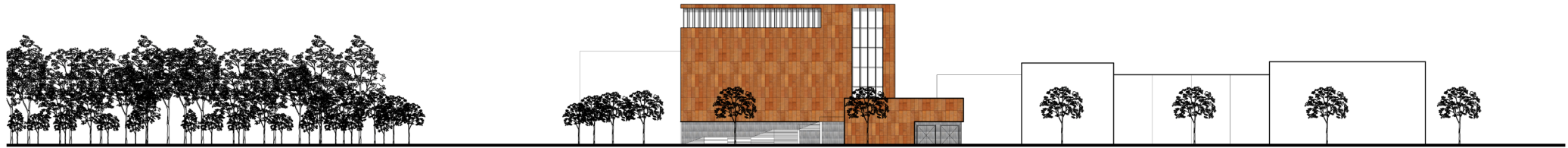



Berlin
Depot

Building FAÇADE FRAGMENT

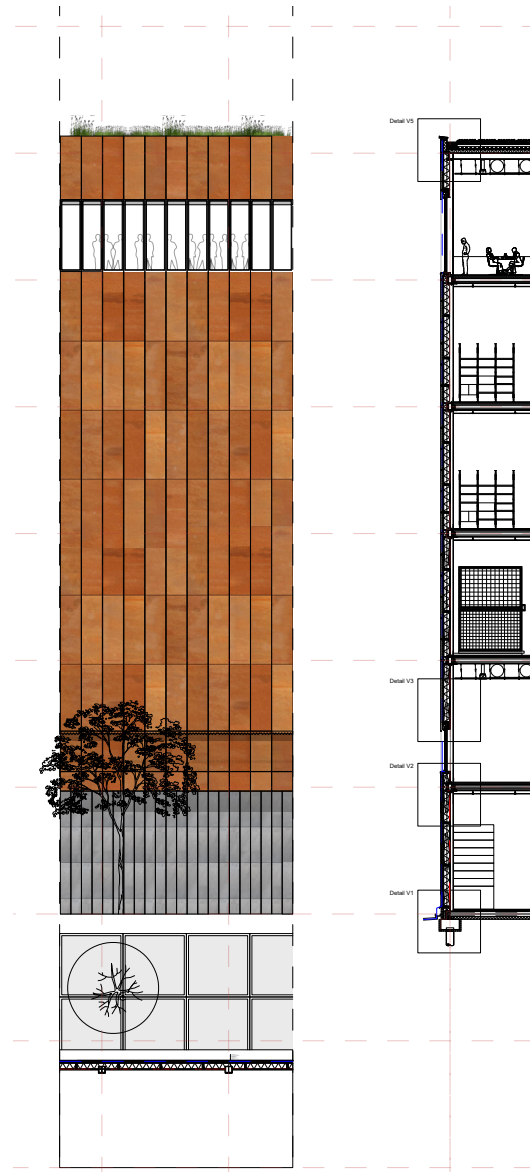

Façade fragment 1:200

Building ENVELOPE FRAGMENT

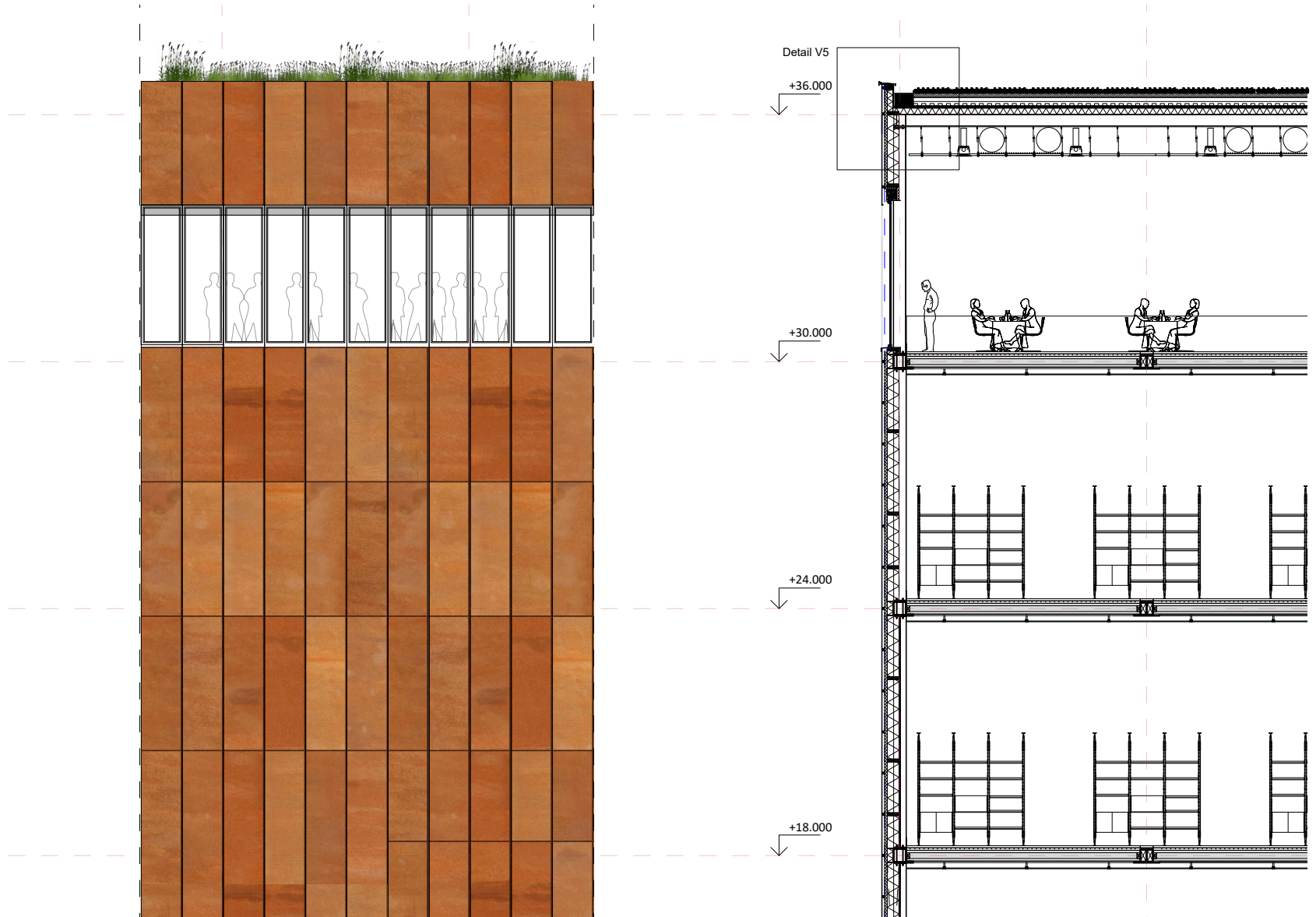

Façade fragment 1:100

Building ENVELOPE FRAGMENT

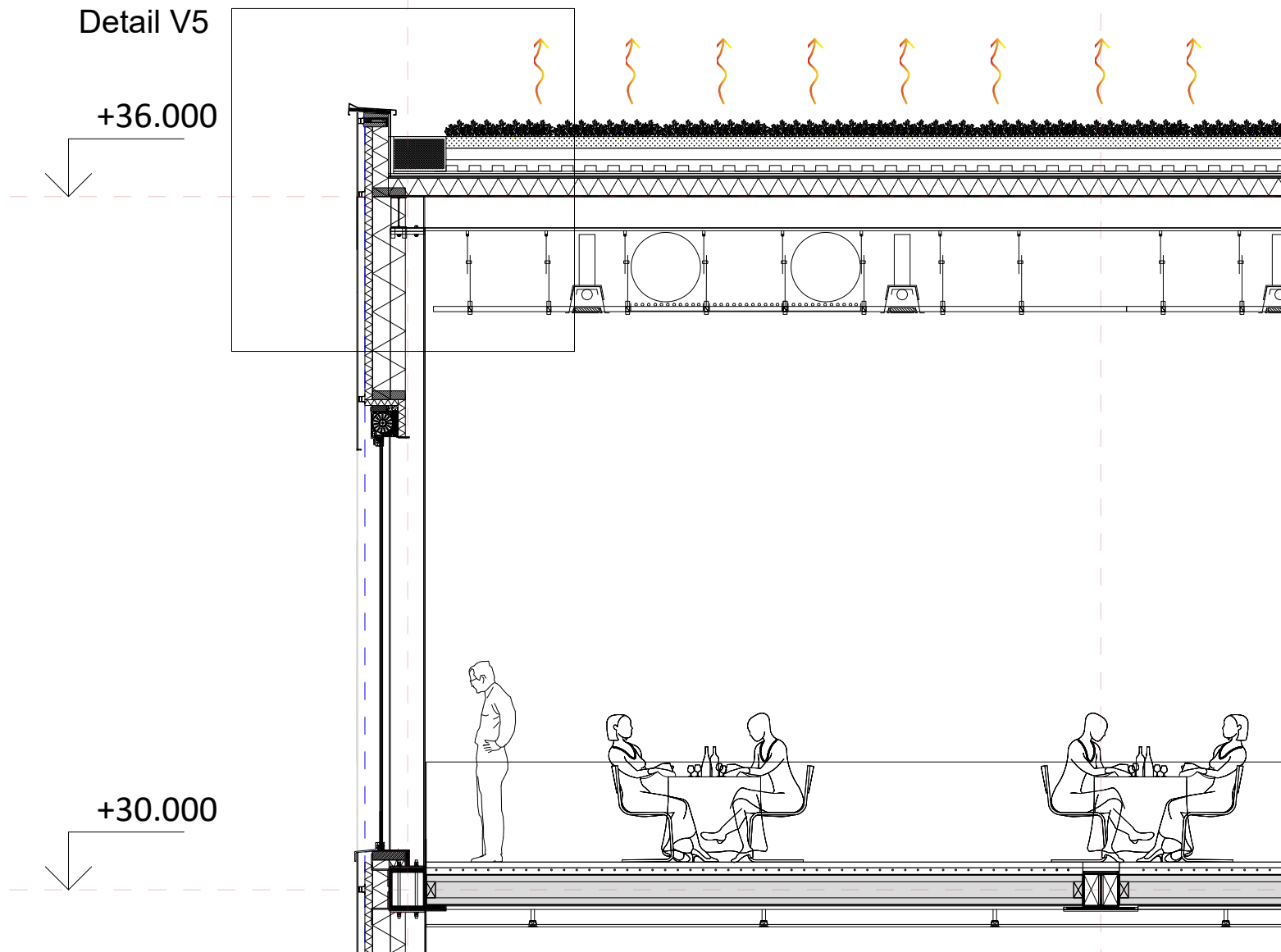

Façade fragment
Urban Heat Island Measure

1:50

Building GREEN ROOF **DETAIL**

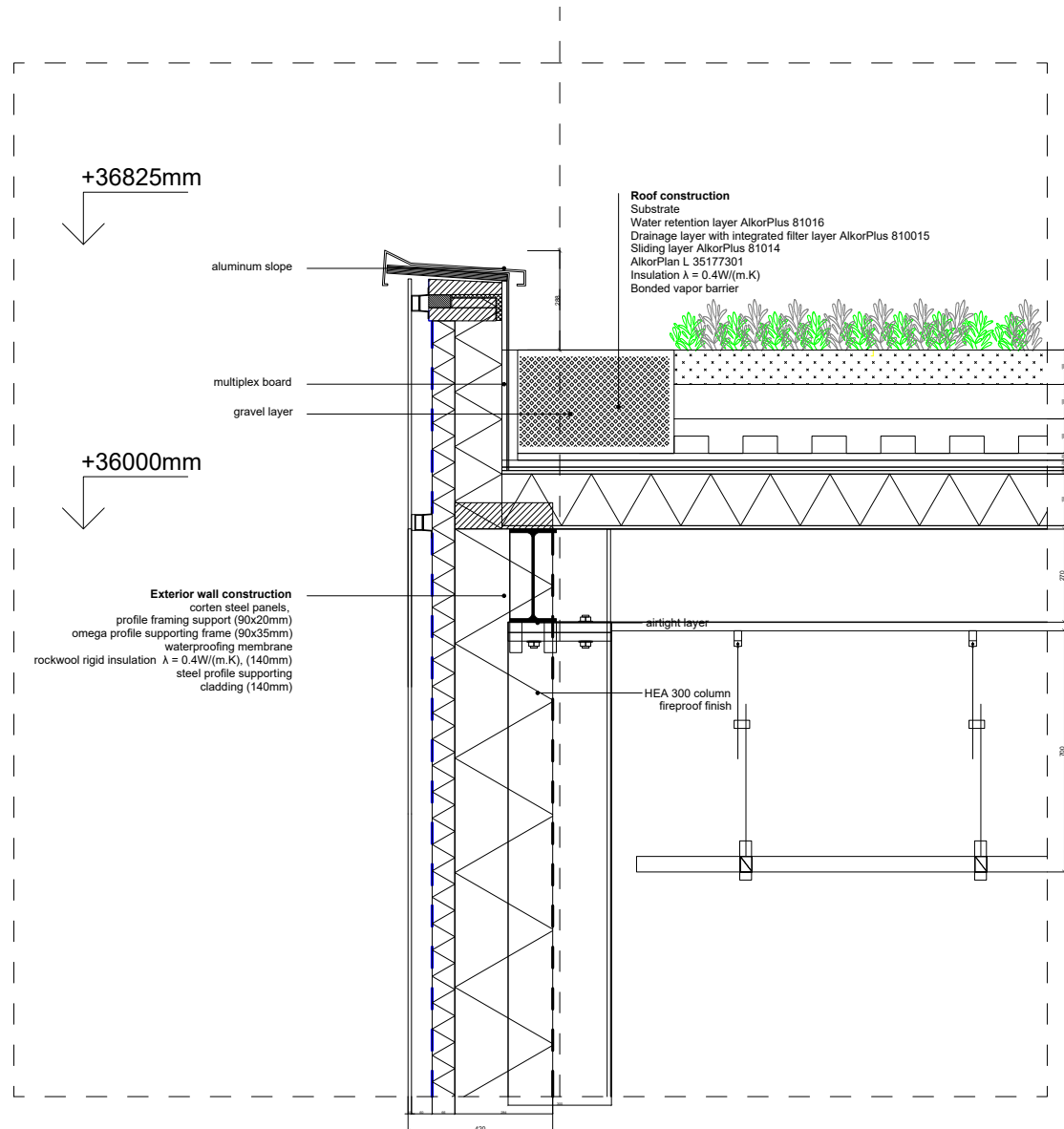

Detail green roof 1.10

Building

EXTERIOR OPENING **DETAIL**

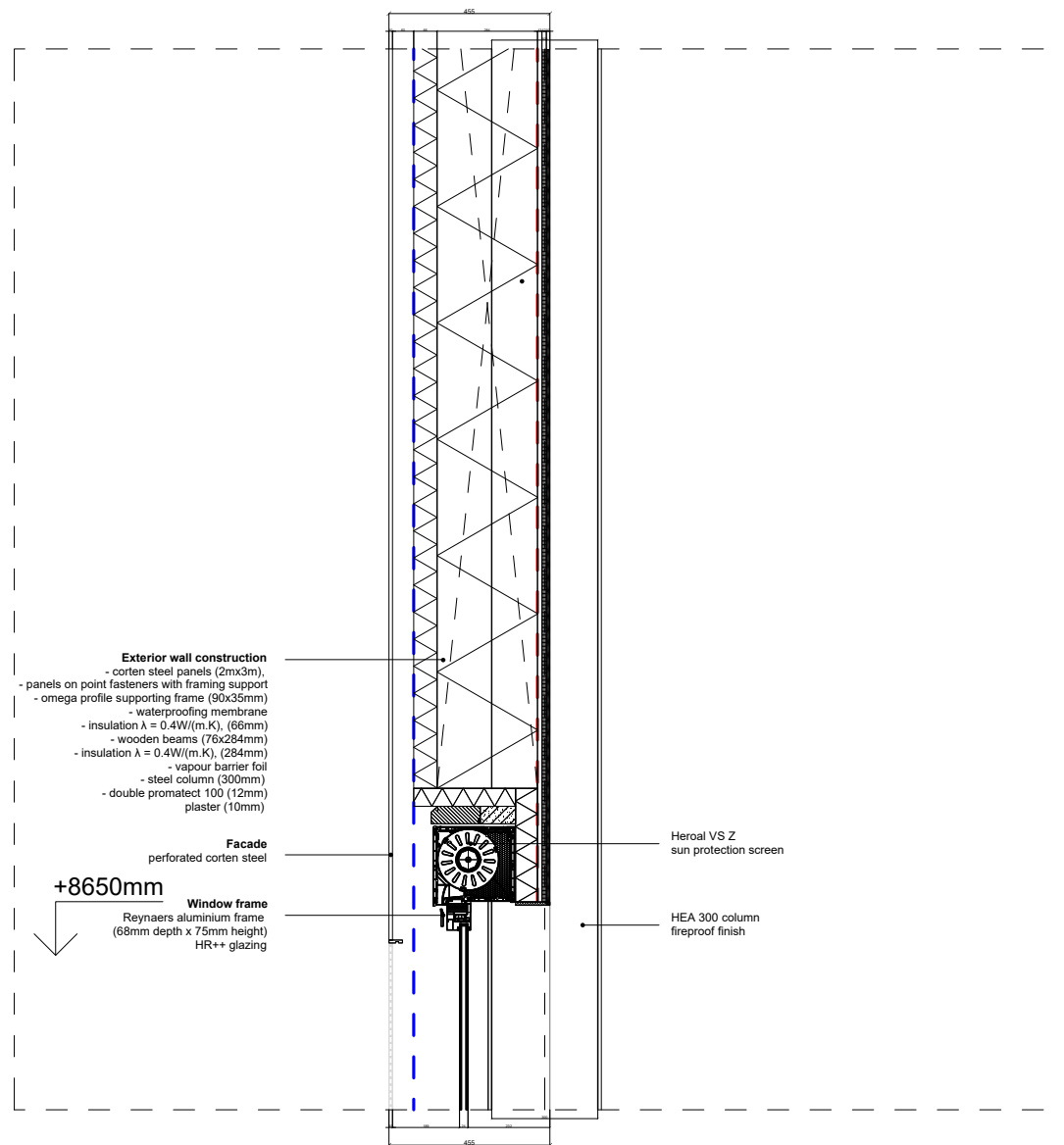

Detail sun protection
Restaurant and event space

1.10

Building

EXTERIOR FACADE **DETAIL**

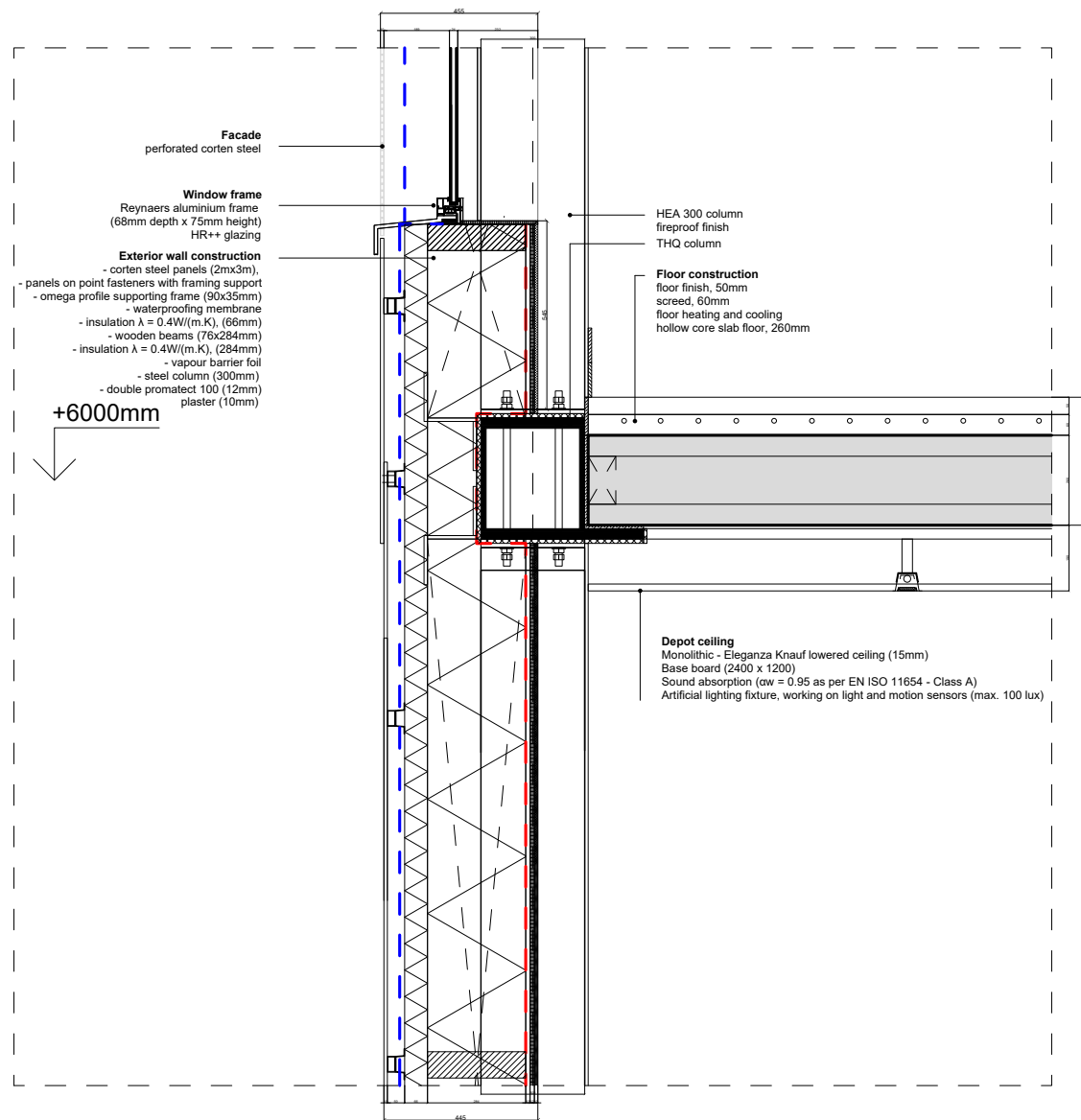

Detail window frame
Office spaces

1.10



Berlin
Depot





Berlin
Depot

Berlin
Depot

Building

INTERIOR WALL **DETAIL**

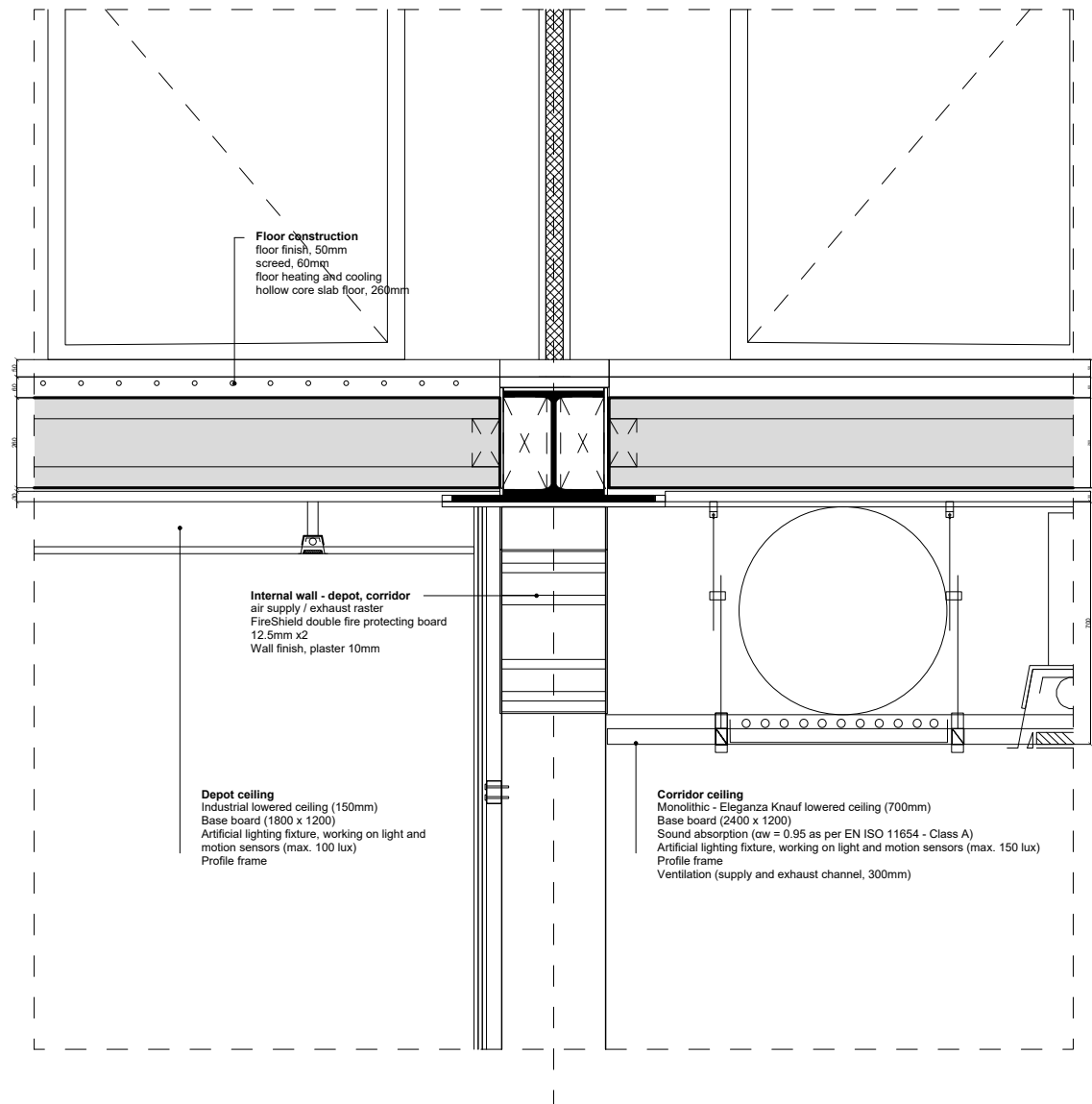

Detail floor and wall
 Depot versus corridor

1.10

Building DETAIL LIGHTING

space	artificial / daylight	light system	lux
exhibition	artificial / daylight	ceiling spots	200
depot	artificial	movement sensor	50
restoration	daylight	north oriented	50

purpose museum lighting:
optimal and attractive vision +
minimum damage

museum-depot lighting

Building

GROUND FLOOR **DETAIL**

construction

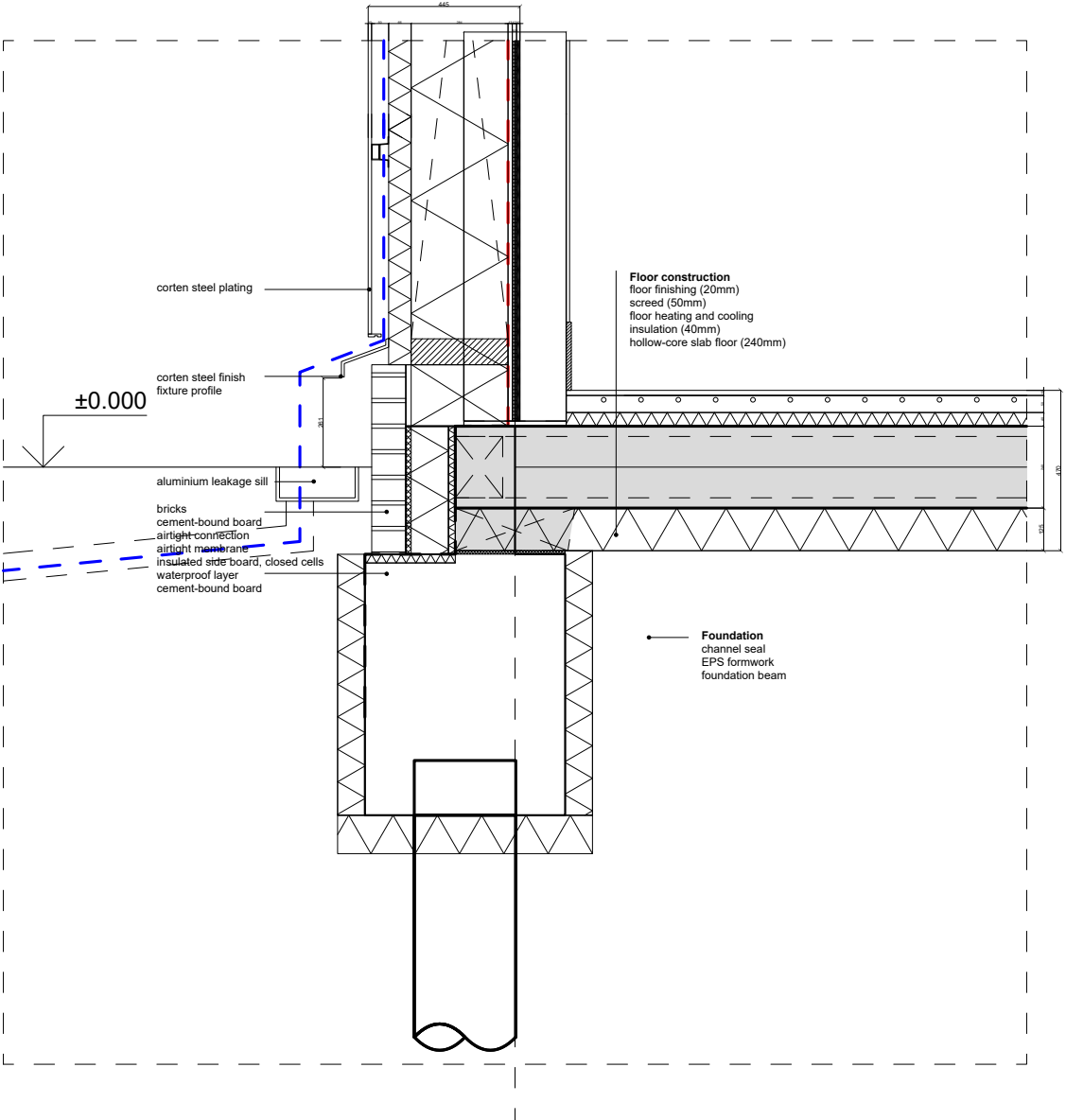

Detail ground floor
Depot spaces

1.10







BERLIN OPEN DEPOT



THANK YOU.