

**P5** *presentation*

GRENFELL TOWER MEMORIAL

*Mourning & Reattachment*

*Architectural Design Crossovers*

M.P. Lauri

GREATING ONLY

**NO WORDS 2 EXPLAIN**

May your hearts be at peace and give you strength.  
Rev. Anil G. M.

**RIP FOR EVERYONE**

May you all RIP  
May Allah bless you all  
We pray for you  
all the survivors you  
are in our thoughts and prayers.  
Soff, Maryam, Hanifa

Who passed  
The pain the  
Can't explain words  
But very all here to  
you love shade.

Love + Peace  
Rom Dahlia & Charis  
GARDNER & A

This is so sad  
& all of us  
Mury G.

I live on the next street!  
What I missed  
May you RIP

My lovely Nadia and  
Mierna Fatima I don't  
know why you are  
not answering my  
calls but I am  
Not giving up  
Sonia x

MAY GOD CONTINUE TO WATCH  
OVER YOU ALL. WE ARE ALL  
PRAYING & CRYING WITH YOU  
AND YOU ARE NOT ALONE.  
LONDON IS WITH YOU.  
STAY BLESSED AND KEEP  
FAITH AND HOPE ALIVE.  
MUCH LOVE & BLESSINGS

MAY YOUR MEMORY  
LIGHT OUR WAY,  
FAISEZ  
15/10/17

My heart is  
Bleeding!!!

GOD BLESS  
AND HELP  
EVERYONE,  
GOD MAKE  
IT EASY  
ON US ALL,  
GOD JUDGE  
AGAINST  
THOSE  
RESPONSIBLE  
AMIN

RIP YASEEN AND  
HIS FAMILIES, my heart  
is with them.  
Inna lillah wa inna ilaiha  
raja'un!

Fight

RIP to all the  
lost innocent lives  
You will forever  
remain in this  
community's hearts and  
prayers.

May the Lord protect  
and guide those  
who survived.  
May all that been lost  
be found in the Lord  
Insha Allah

**JUSTICE**

FROM all  
of us if, may  
you rest in peace  
Amin

BLESS YOU ALL  
I hope you are  
all smiling & happy  
GOD will  
RIP - REST IN  
MAY GOD  
you are  
safe

**RIP**  
MAY GOD GRANT  
you per PEACE  
MAY HE

3 ~~May you~~  
forever rest in  
we are with you.  
My thoughts  
prayers are  
with you  
#Let'slive

PROUD

Why  
Why  
Why

14 / 06 / 2017 *in London*

14 / 06 / 2017



14 / 06 / 2017



72 lost lives



## fire spread explanation

### How did the fire spread

- 1 Fire bursts through window of a room
- 2 Aluminium finishing on the cladding falls away, exposing combustible core
- 3 Fire accelerates failure on nearby panels, flames race through the entire facade
- 5 Flames enter cavities between the building and the panels. They grow ten times their length as they seek oxygen

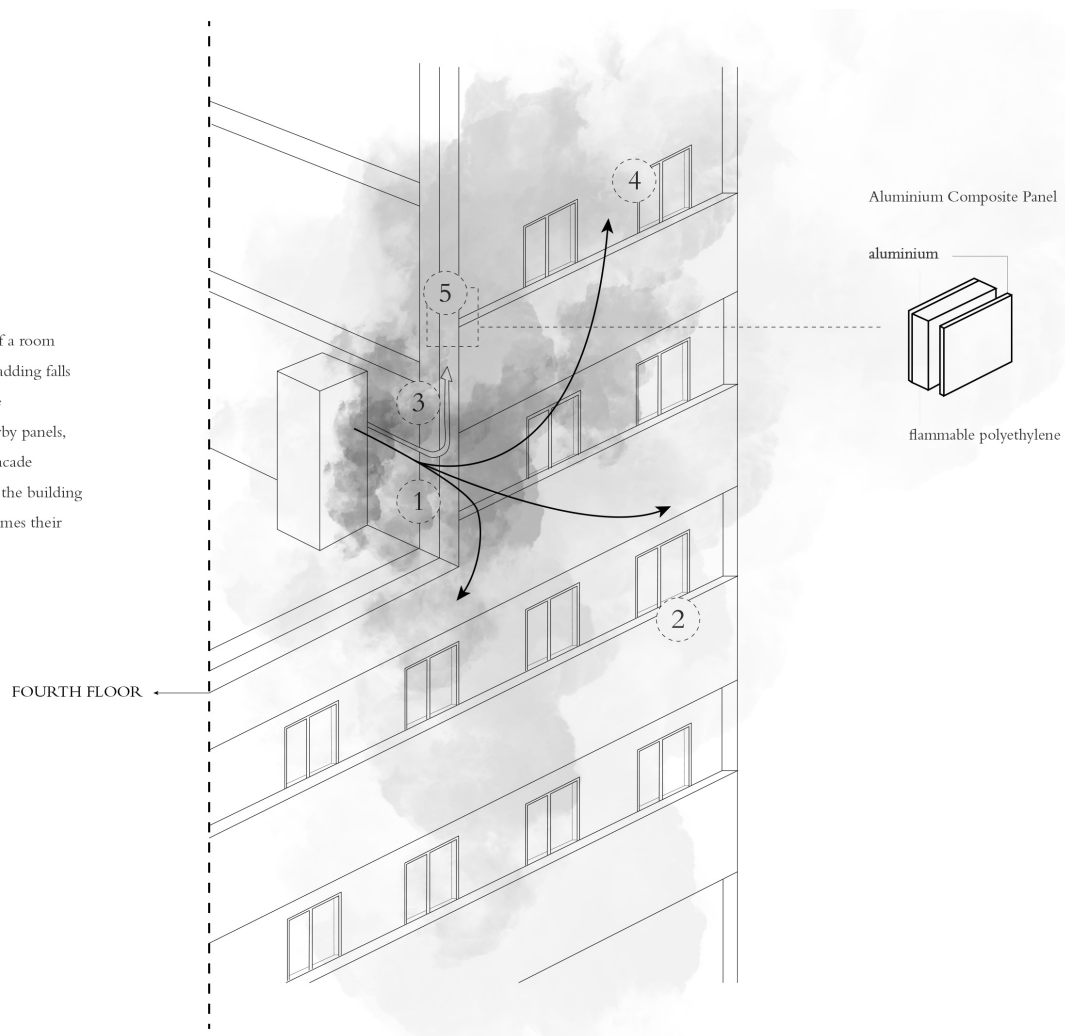

### Location - Kensington & Chelsea

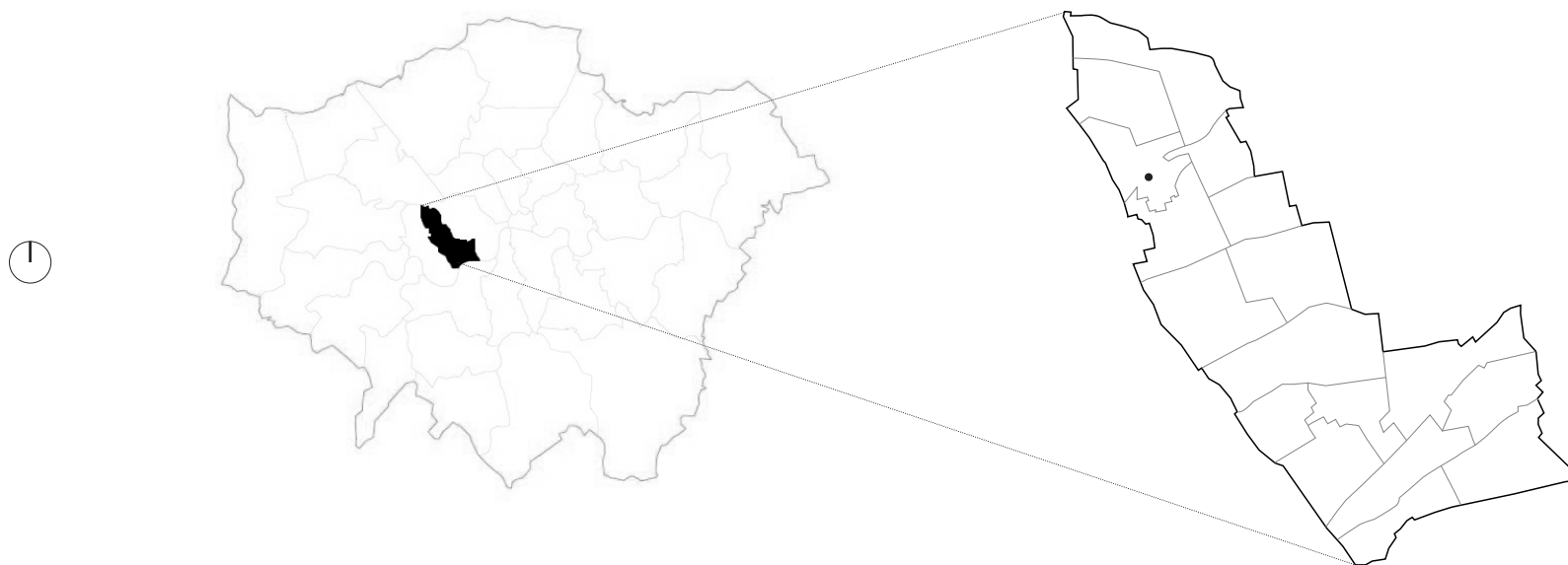



### Location - North Kensington



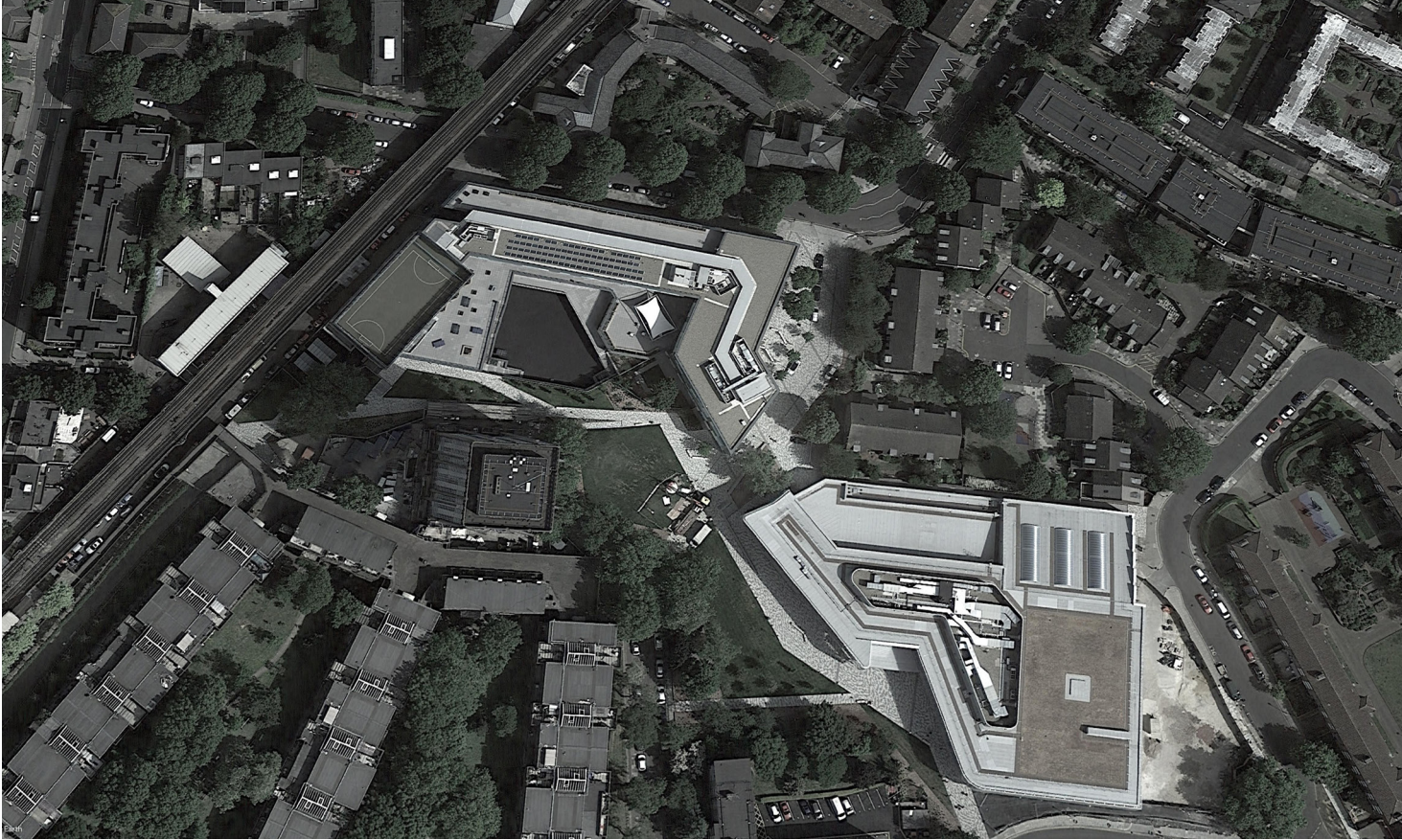

site - before

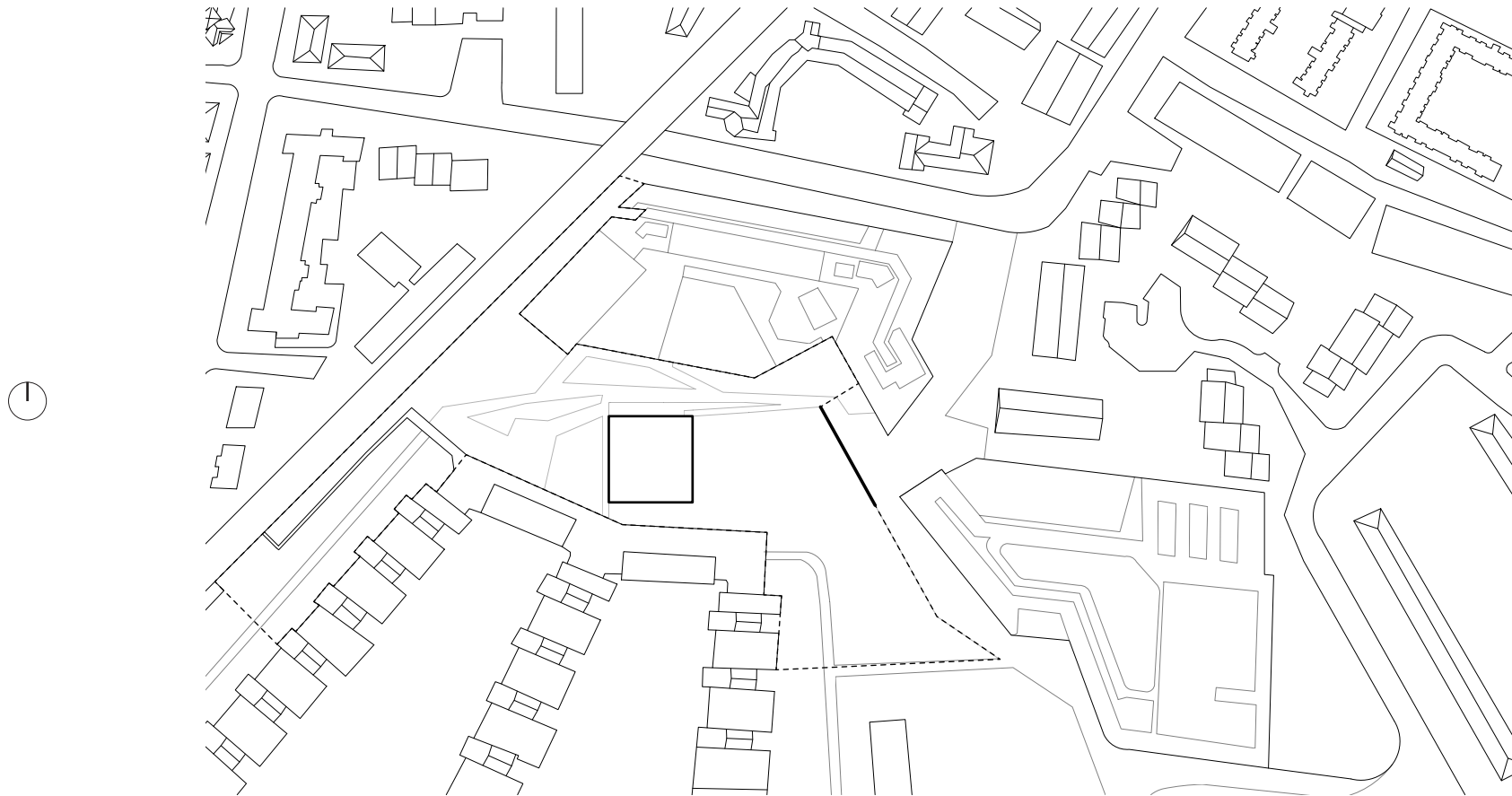

site now? - elements that remain



-  Grenfell
-  memorial wall
-  fenced off

site now



current memorial wall



*"Grenfell Tower's shell will haunt the skyline until 2022."*

- Dipesh Gadhur & Caroline Wheeler in *The Times*, 2018

**Grenfell initiatives - already taken****Political:**

tightened fire safety regulations

leaseholders responsible for fire safety related bills (2021)

**Social:**

silent walk once a month

events on the anniversary

community support

**Architectural: ?**

demolition - 2022

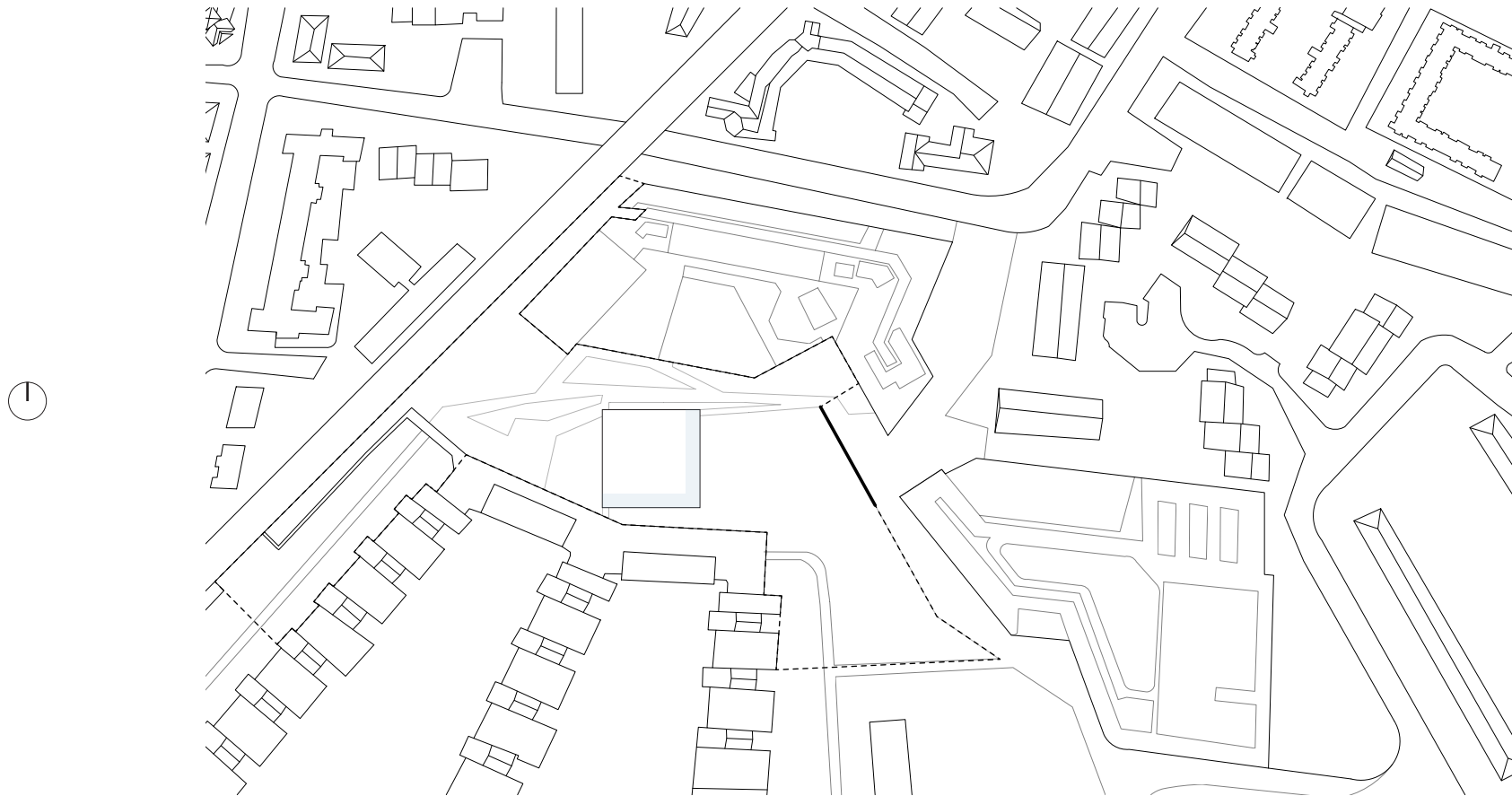

□ perimeter  
- - - fenced off

demolition - change in the skyline

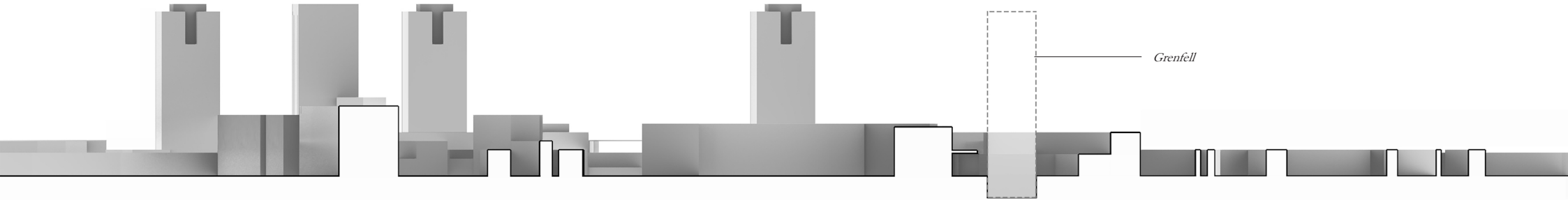



**issues that remain****Architectural: ?****Social:**

the Grenfell community still feels that nothing has changed

**Material:**

dangerous cladding used in Grenfell

**Grenfell cladding**



dangerous cladding on other buildings around London



*"2 years after Grenfell this building is still covered in dangerous cladding."/ 2019*



### Charles Booth Poverty maps / Deprivation maps

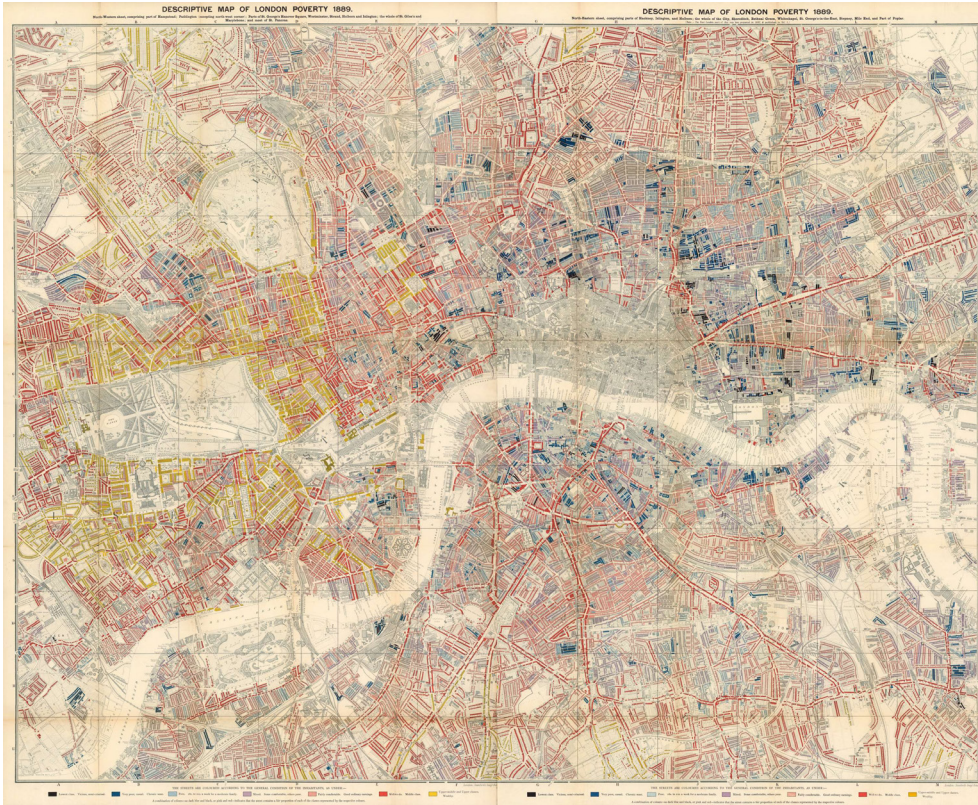

1889



2021

conflict zone



### North Kensington 1889 / Poverty map



### North Kensington 2021 / Deprivation map

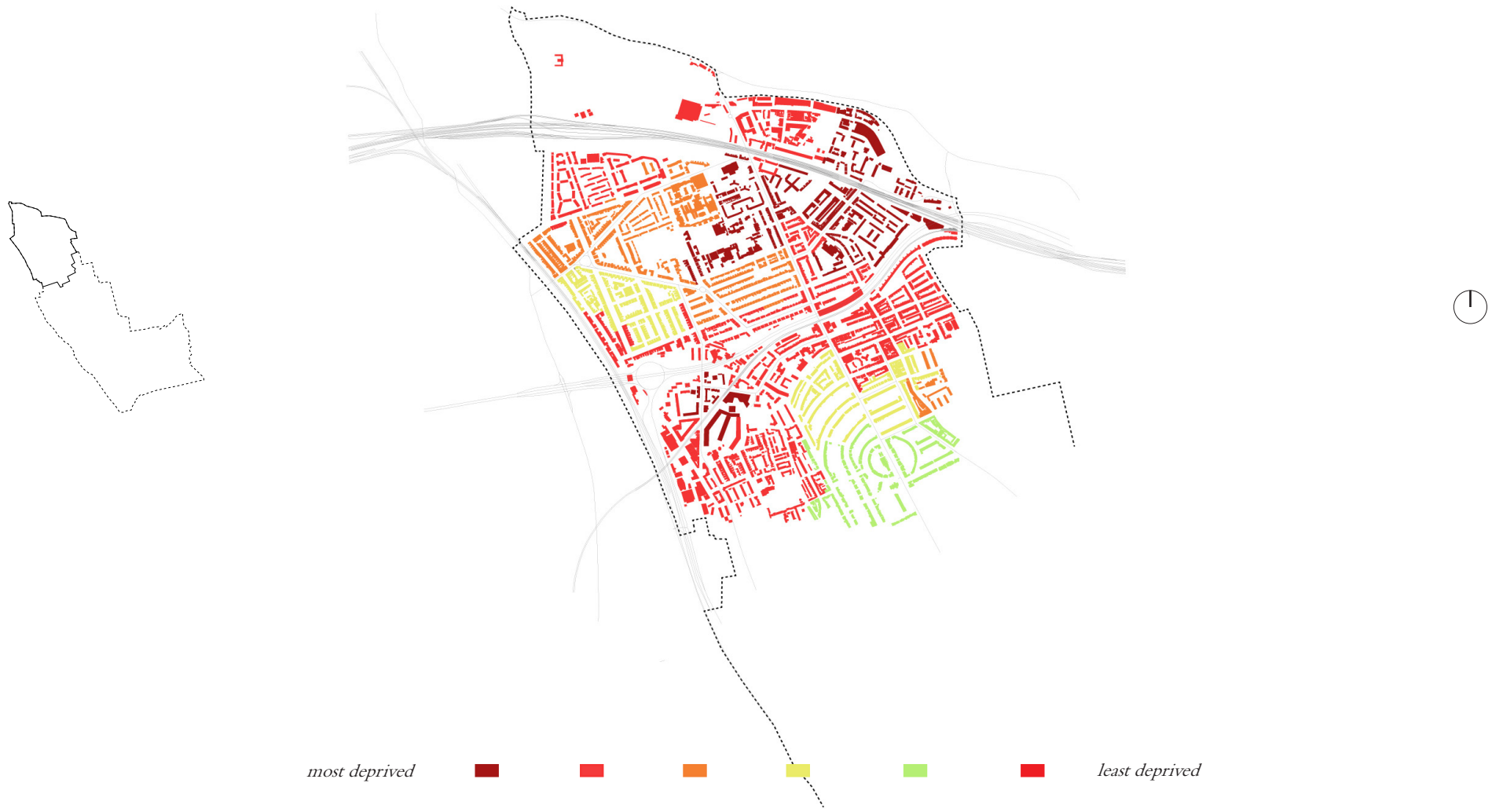



Spatial analysis - imagined conflict zone



**Spatial analysis - non-crossable infrastructure**



**non-crossable infrastructure**



*rail*



*highway*

Spatial analysis - isolated by infrastructure



**Spatial analysis - most deprived** ('squeezed' by infrastructure)



Division - from wealth gap to space gap



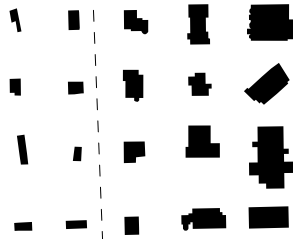
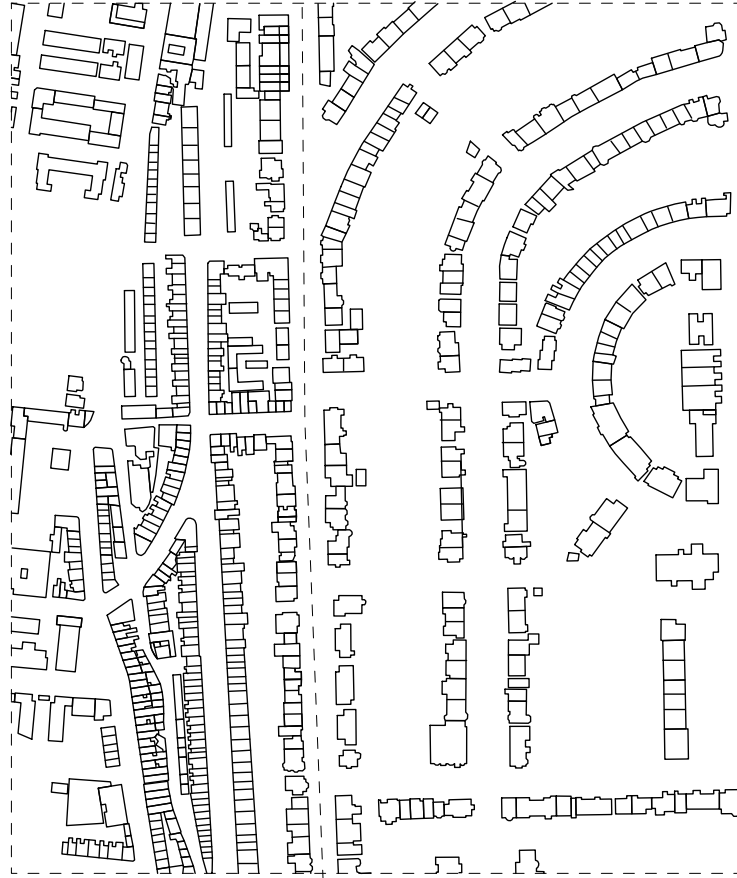
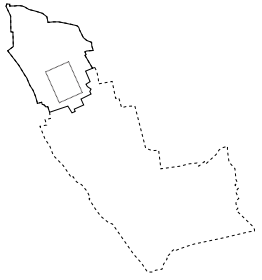

### Spatial analysis - Space Syntax vs. Deprivation



*least accessible*



*most deprived*



*combined*





## Grenfell Tower Inquiry: who's blaming who

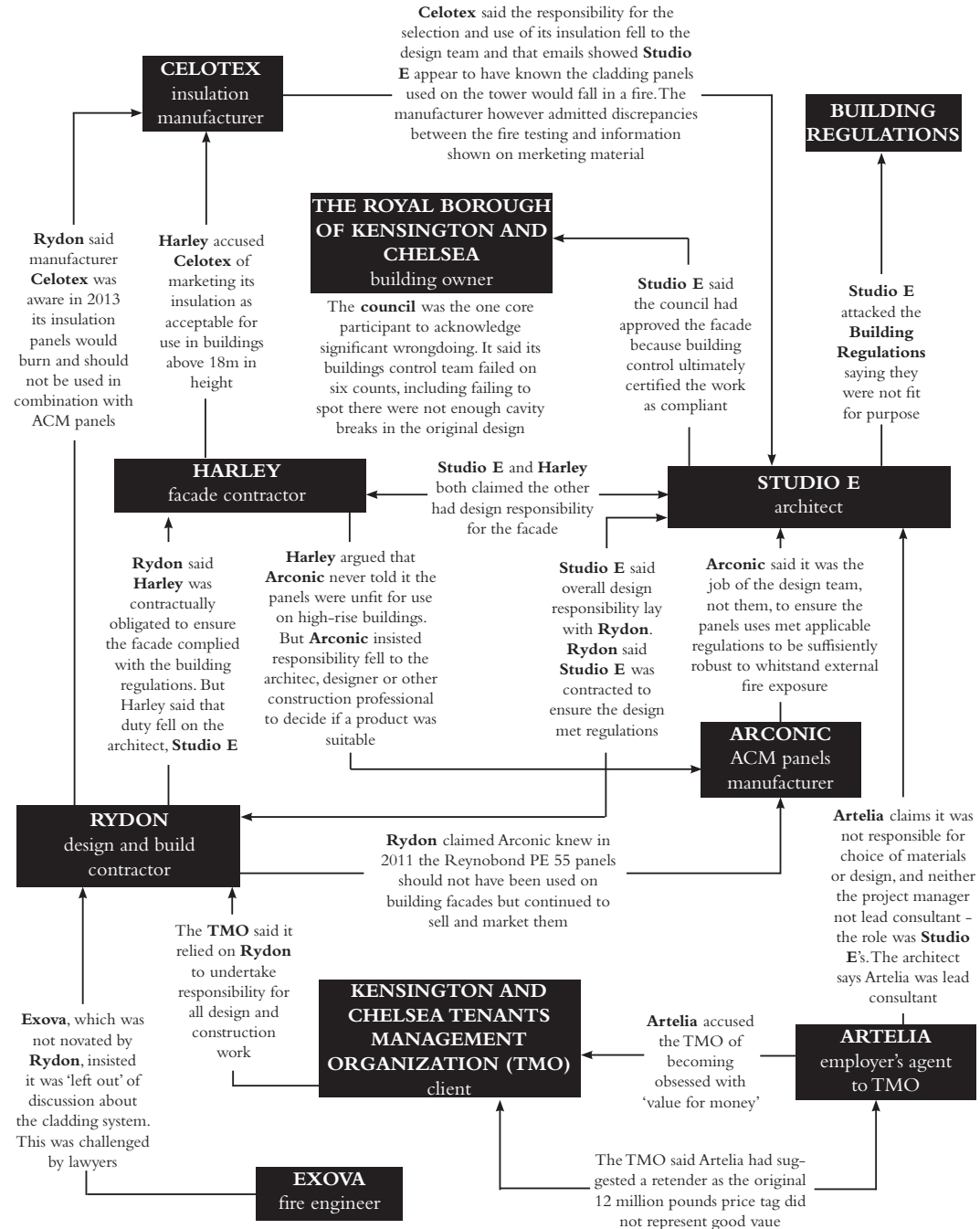

**Grenfell Tower Inquiry:  
who's blaming who**

**THE ROYAL BOROUGH  
OF KENSINGTON AND  
CHELSEA**  
building owner

The **council** was the one core participant to acknowledge significant wrongdoing. It said its buildings control team failed on six counts, including failing to spot there were not enough cavity breaks in the original design

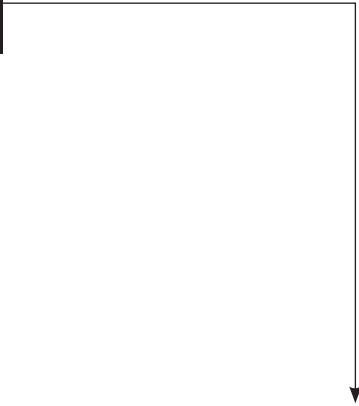

now responsible for all the housing within the Borough

*council*

THE ROYAL BOROUGH  
OF KENSINGTON AND  
CHELSEA

*survivors*



*“We are not asking for money. We are not asking for sympathy. We are demanding change.”*

*homeless*



*“Housing has become a financial asset rather than a basic right.”*

memorial

## Architecture of (social) trauma

*“We have a great need to memorialize.”*

*“We need marks in history - something to bring us back to that moment.”*

*“Memorial as a means to materialize intangible emotions - creating collective memories.”*

- Sabina Tanovic, Memory in Architecture (2015)

Architecture of (social) trauma

MEMORIAL MUSEUM

MONUMENT

STORY TELLING

NARRATIVE

INTERACTIVE

ABSTRACT

EMPTY

SILENT

BERLIN  
Jewish Museum

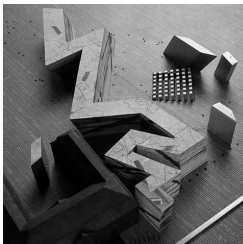

past

Architecture as a means of narrative and emotion. Expressing feelings of absence & emptiness (empty spaces, dead ends, dark vs. light) Not a museum but an experience.

Daniel Libeskind

COLOMBIA  
Memory, Peace and Reconciliation Center



present

Built in the middle of the current internal conflict unlike other similar projects that have been built after the conflict has ended. The remembrance of more than six million victims of the Colombian internal conflict.

Juan Pablo Ortiz Arquitectos

NEW YORK  
911 Memorial/Museum



past

Pavilion, museum, and a memorial plaza. Tells the story through displays, narratives, archives, and monumental artifacts.

Michael Arad  
Peter Walker

ALABAMA  
National Memorial of Peace & Justice

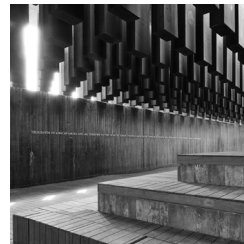

present

Ongoing aspect of the design. 800 hanging pieces, 800 waiting to be adopted by counties. Over time, absence will reveal who helped spreading the message.

MASS

VIETNAM  
Veterans Memorial



past

Visual scar in the city.

Maya Lin

OTTAWA  
National holocaust Monument



past

Orientation & entry, gathering, interpretation, memory, stair of hope. Star symbolism.

Daniel Libeskind

BERLIN  
Field of Otherness



past

Lost in space. Not a cemetery. No symbolism. Architecture marks collective memory and a moment in time. (multi-use : eating lunch, playing, mourning, photography)

Peter Eisenman

Architecture of (social) trauma

MEMORIAL MUSEUM

MONUMENT

STORY TELLING  
NARRATIVE  
INTERACTIVE

ABSTRACT  
EMPTY  
SILENT

BERLIN  
Jewish Museum



past

Architecture as a means of narrative and emotion. Expressing feelings of absence & emptiness (empty spaces, dead ends, dark vs. light) Not a museum but an experience.

Daniel Libeskind

COLOMBIA  
Memory, Peace and Reconciliation Center



present

Built in the middle of the current internal conflict unlike other similar projects that have been built after the conflict has ended. The remembrance of more than six million victims of the Colombian internal conflict.

Juan Pablo Ortiz Arquitectos

NEW YORK  
911 Memorial/Museum



past

Pavilion, museum, and a memorial plaza. Tells the story through displays, narratives, archives, and monumental artifacts.

Michael Arad  
Peter Walker

ALABAMA  
National Memorial of Peace & Justice

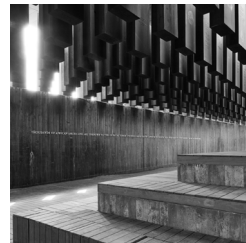

present

Ongoing aspect of the design. 800 hanging pieces, 800 waiting to be adopted by counties. Over time, absence will reveal who helped spreading the message.

MASS

VIETNAM  
Veterans Memorial



past

Visual scar in the city.

Maya Lin

OTTAWA  
National Holocaust Monument



past

Orientation & entry, gathering, interpretation, memory, stair of hope. Star symbolism.

Daniel Libeskind

BERLIN  
Field of Otherness

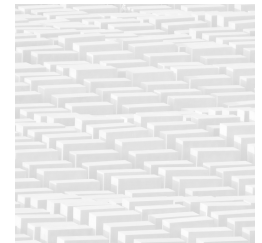

past

Lost in space. Not a cemetery. No symbolism. Architecture marks collective memory and a moment in time. (multi-use : eating lunch, playing, mourning, photography)

Peter Eisenman



## clues from psychology

In psychology, Peter Homans describes the trajectory of loss as follows:

attachment - loss - grieving - **mourning - reattachment**

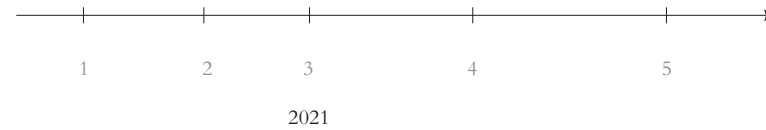

Peter Homans, *Symbolic Loss: the Ambiguity of Mourning and Memory at Century's End* (2000)

### Mourning & Reattachment

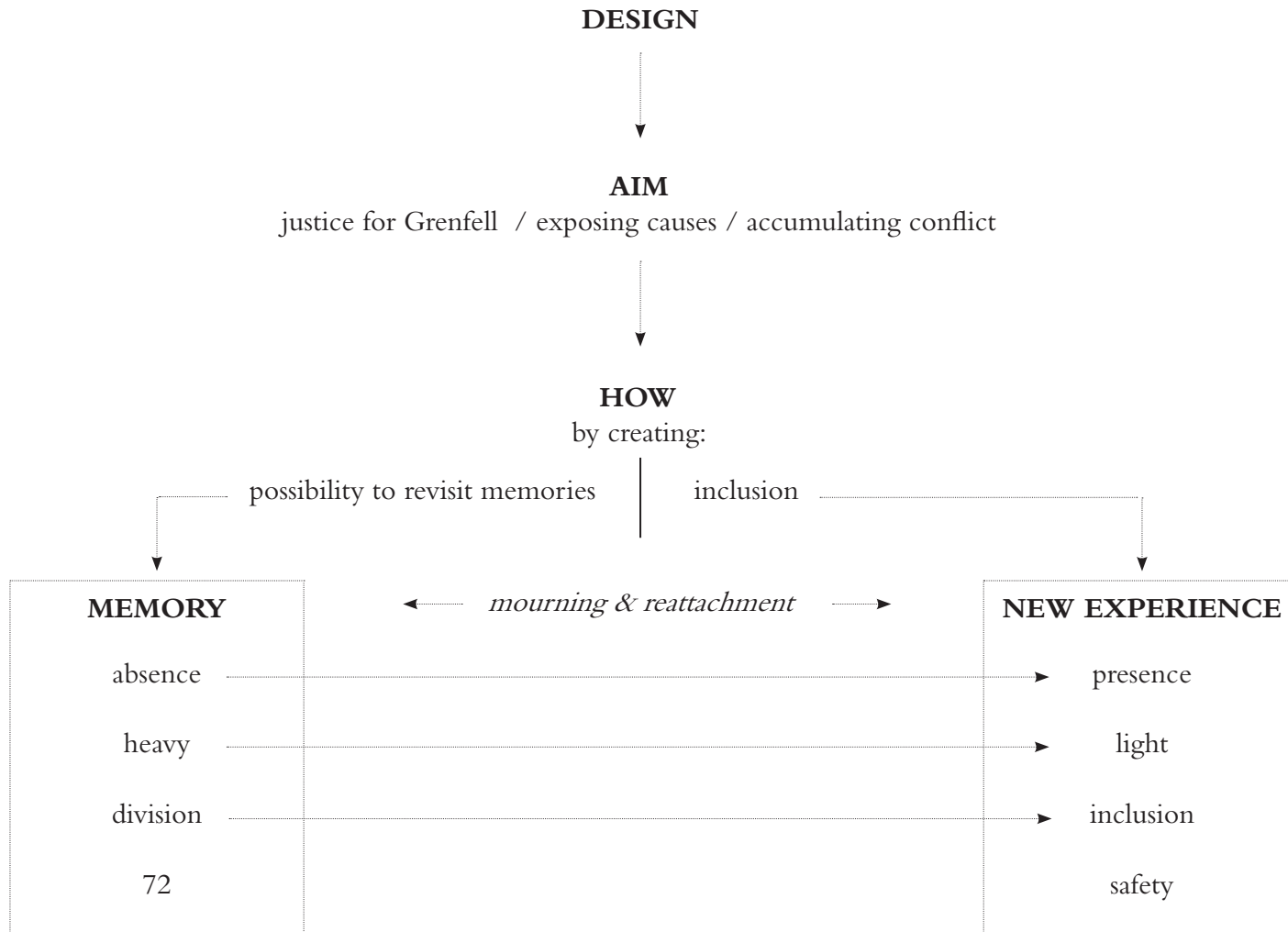

program

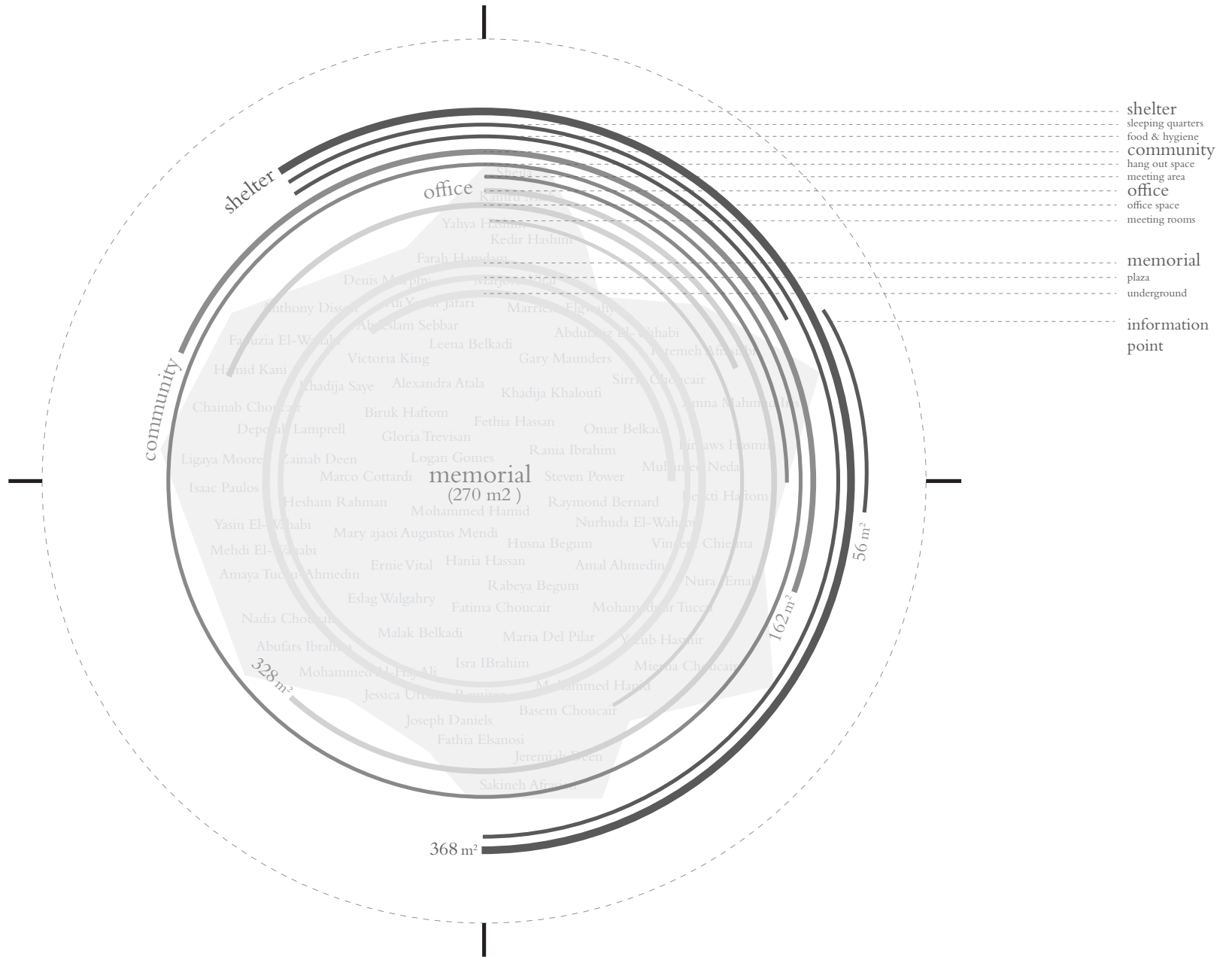

concept

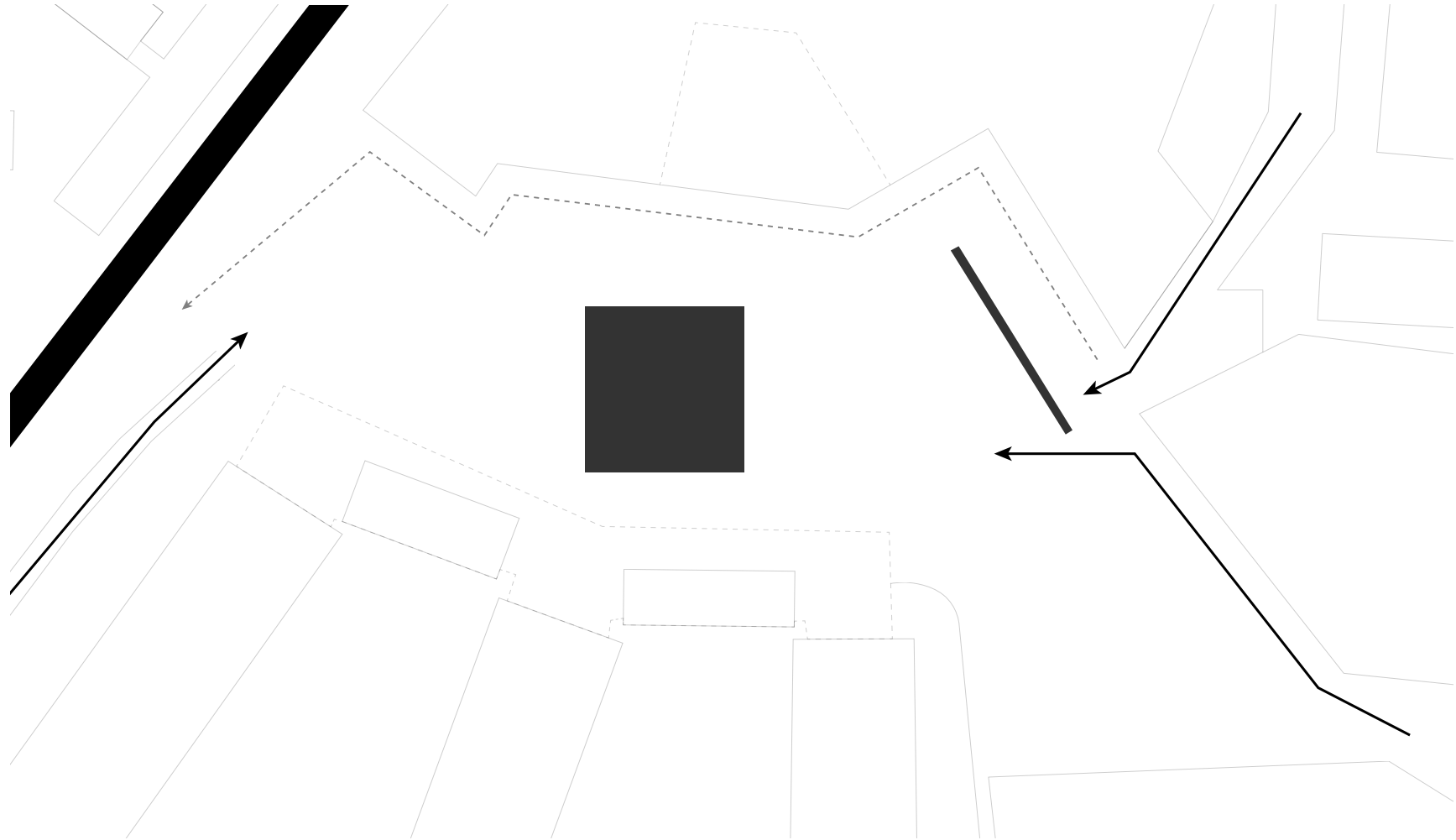

approach

concept

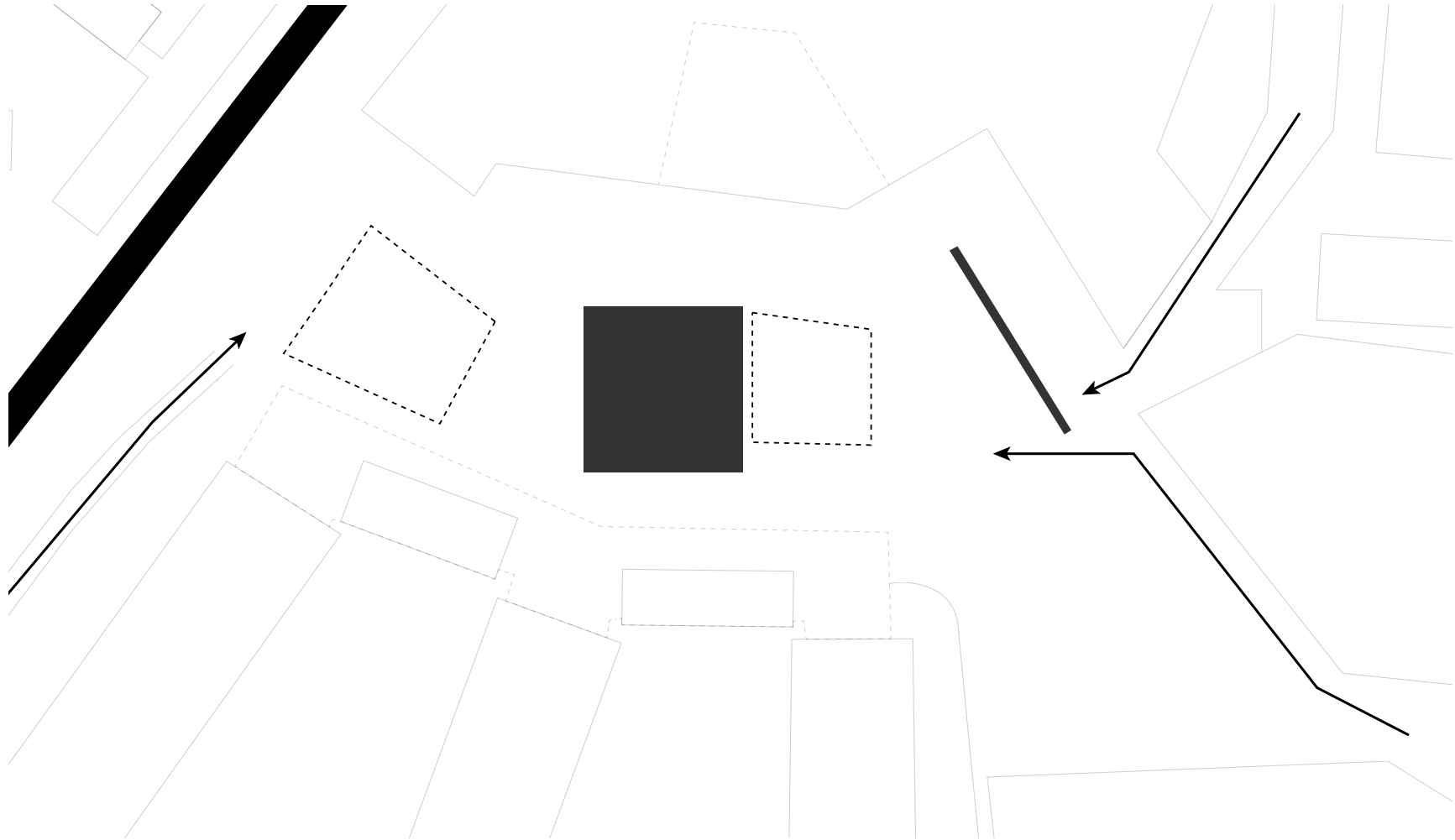

old - new

concept

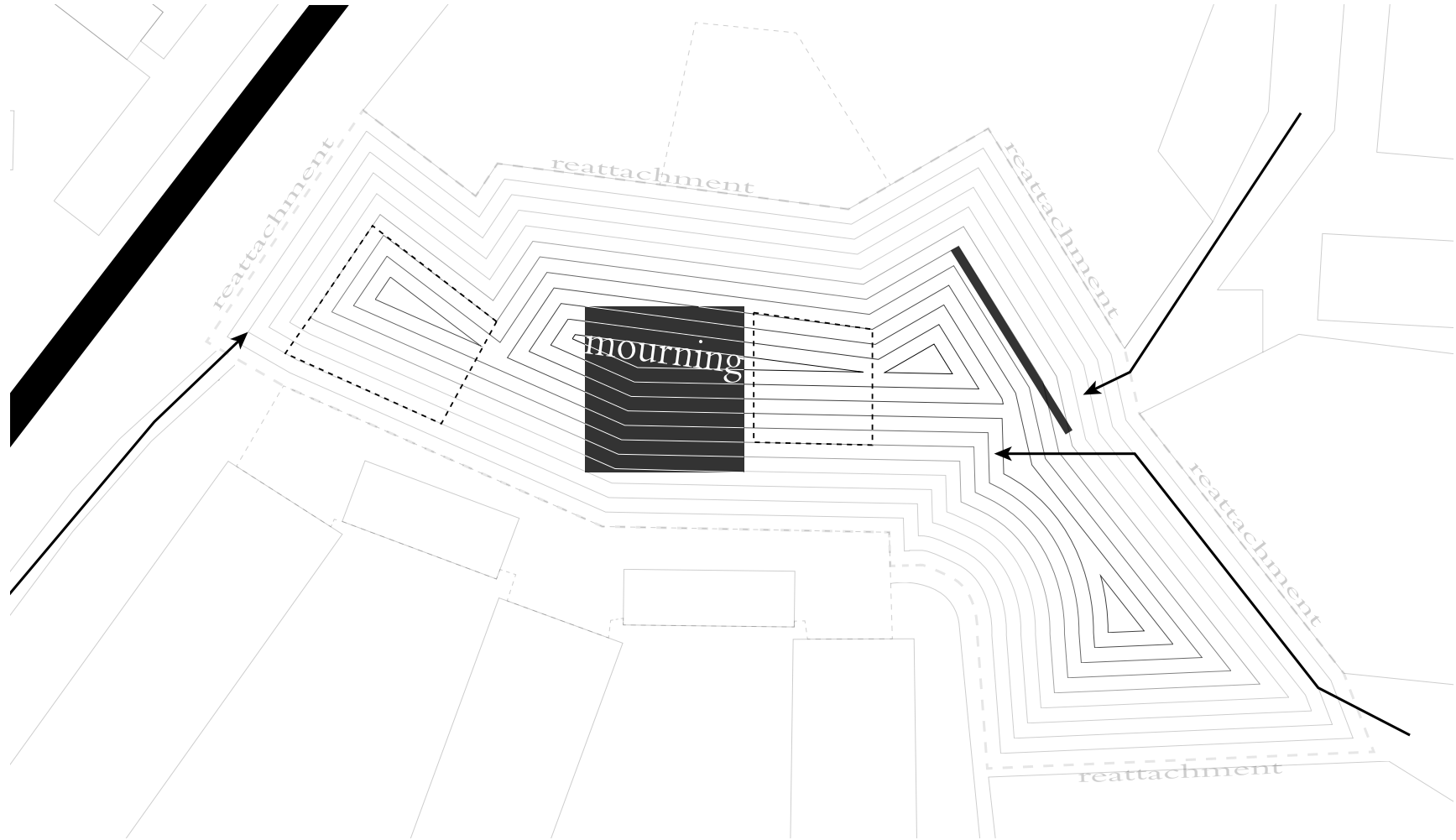

gradient

concept

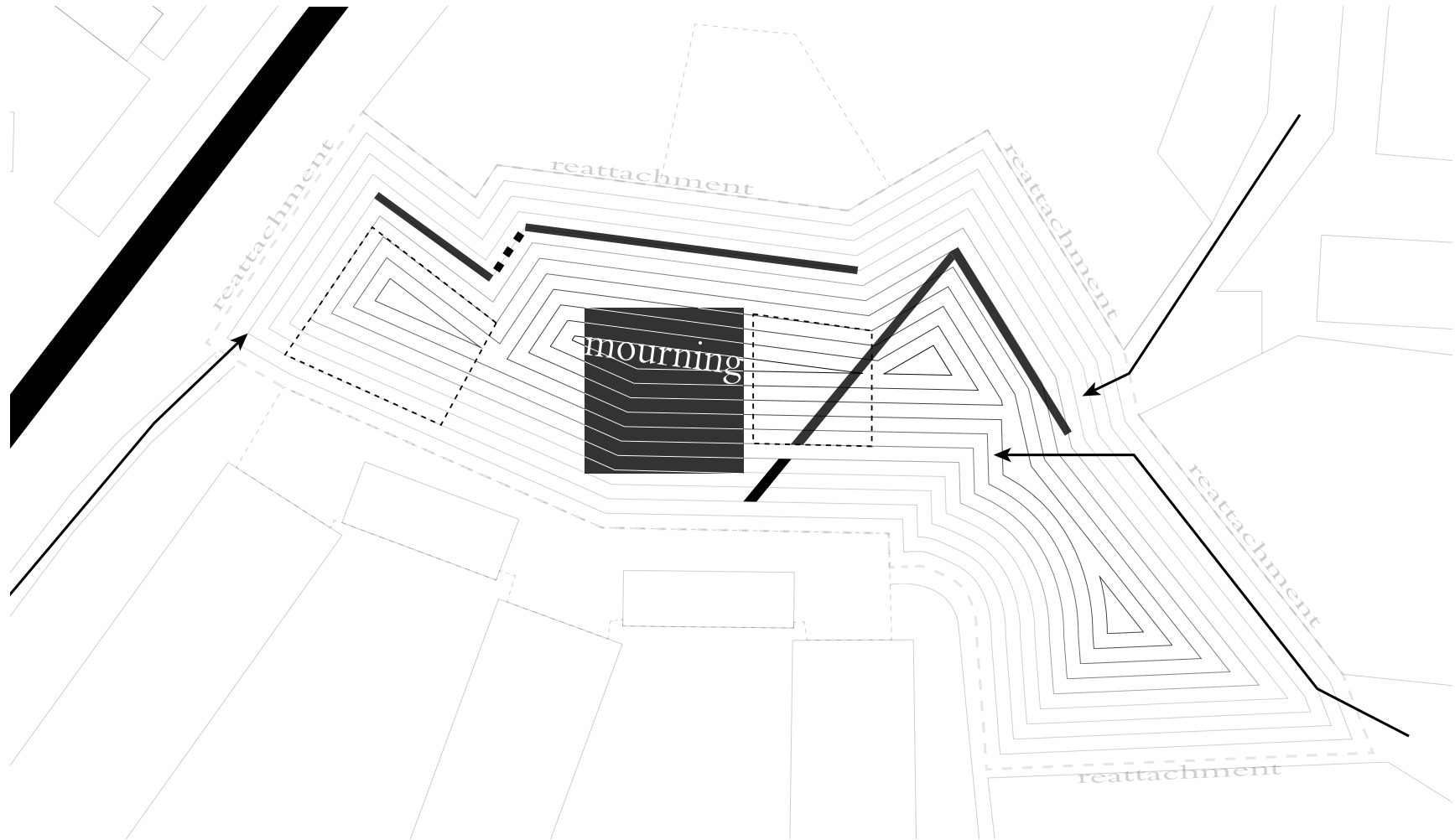

walls

concept

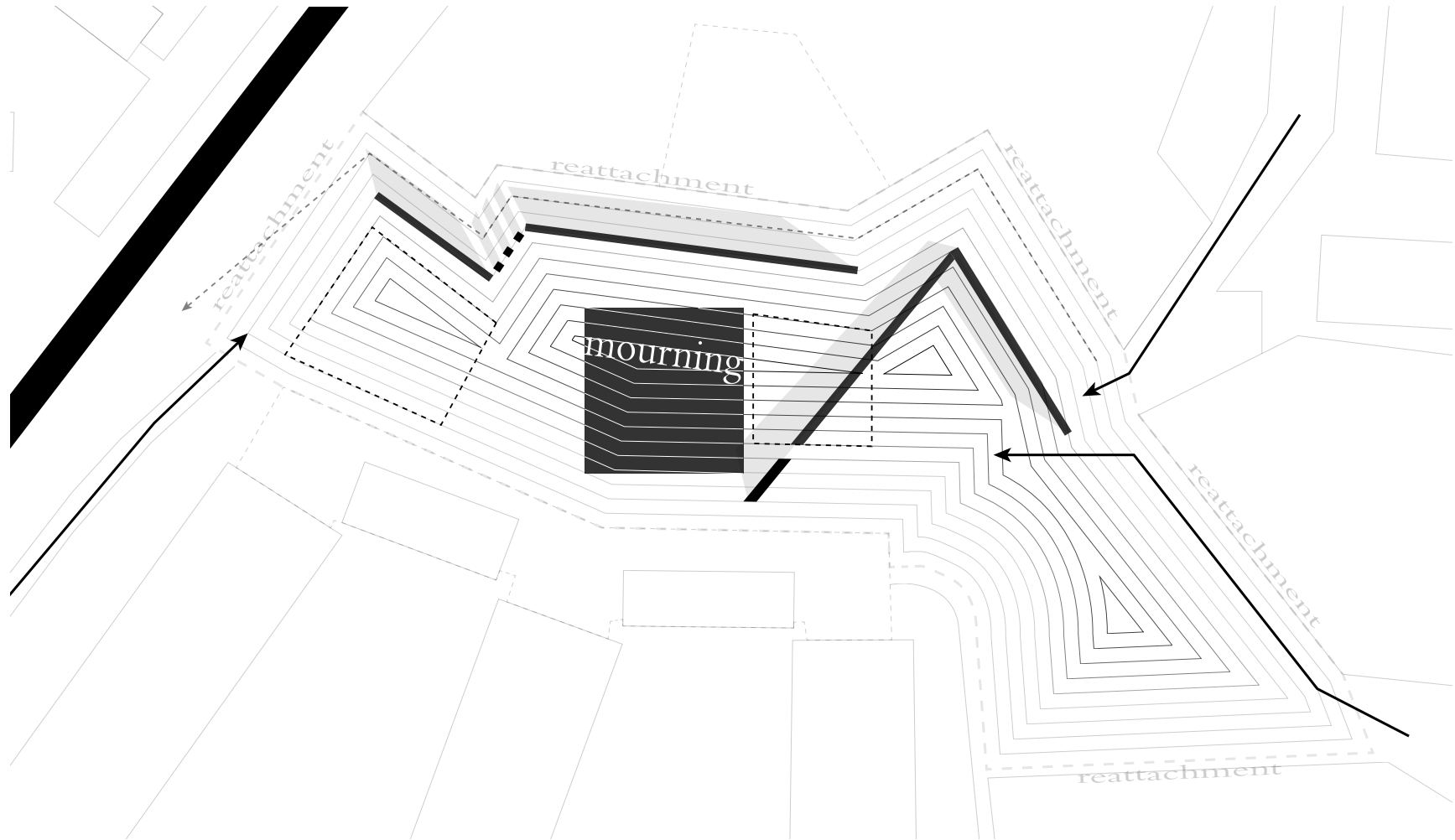

shadows



concept

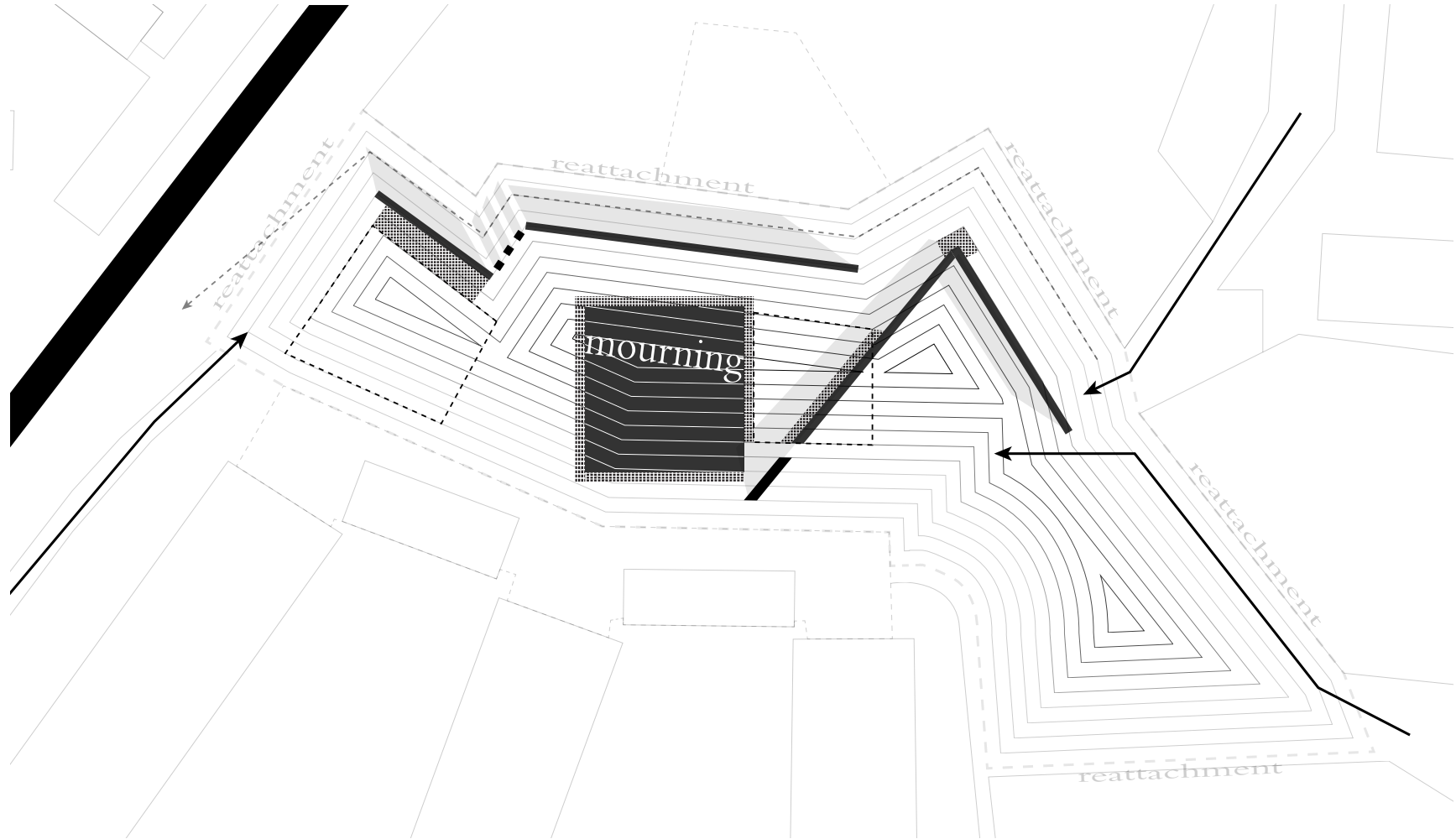

tension

concept

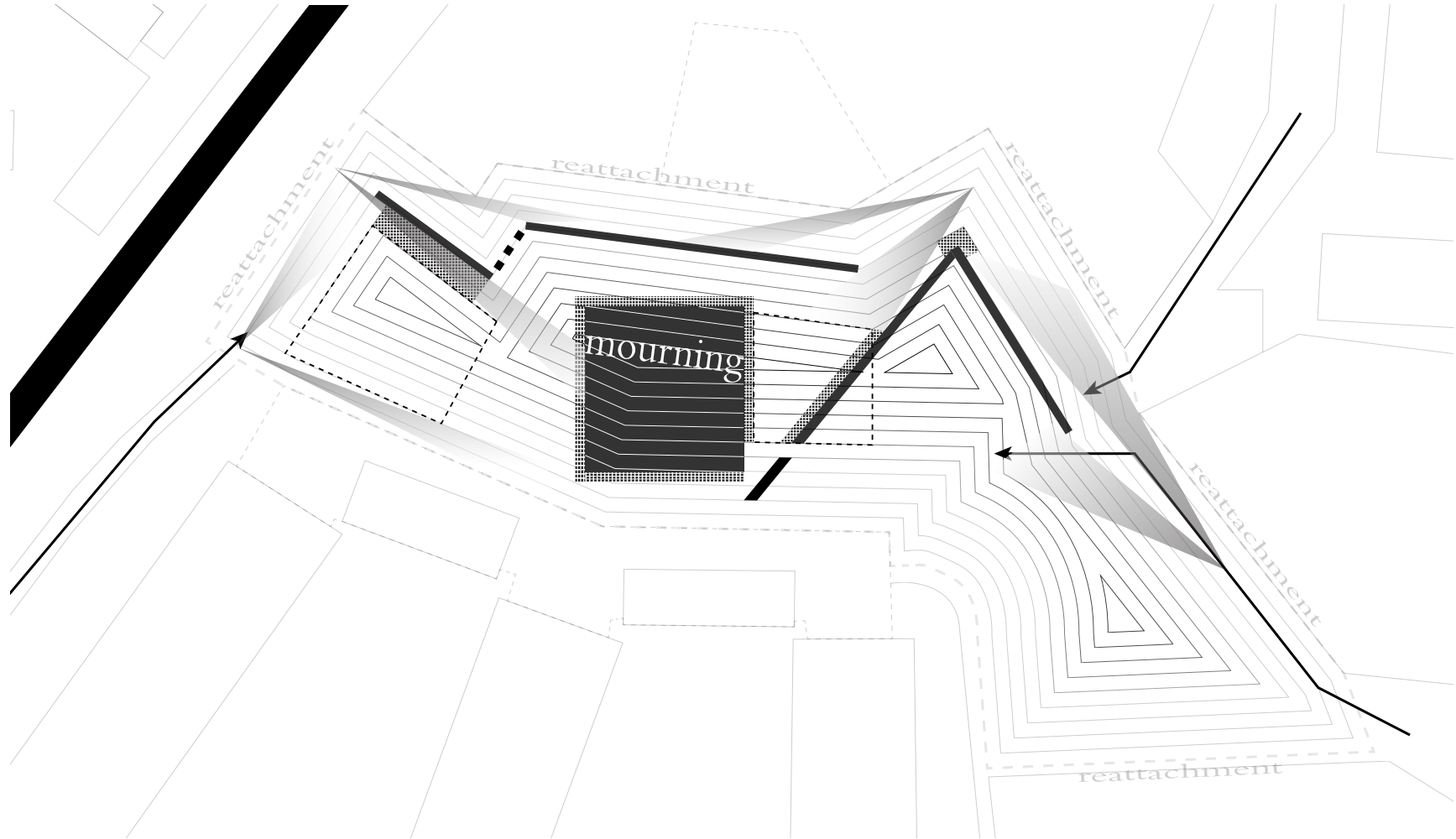

view lines

experience

**experience 1 / approach**



experience 1 / panels



Aluminium composite panel with a flammable polyethylene core was implemented on the Grenfell Tower's facade during its refurbishment in 2016.

This dangerous material is still on the facades of numerous buildings around London.

The process of taking them down will be displayed on this wall.

9  
9  
1  
3  
W  
i  
n  
d  
s  
o  
r  
R  
o  
a  
d  
L  
o  
n  
d  
o  
n  
W  
2  
8  
9  
P  
B

*Aluminium composite panel with a flammable polyethylene core was implemented on the Grenfell Tower's facade during its refurbishment in 2016.*

*This dangerous material is still on the facades of numerous buildings around London.*

*The process of taking them down will be displayed here.*

**experience 2 / new functions**

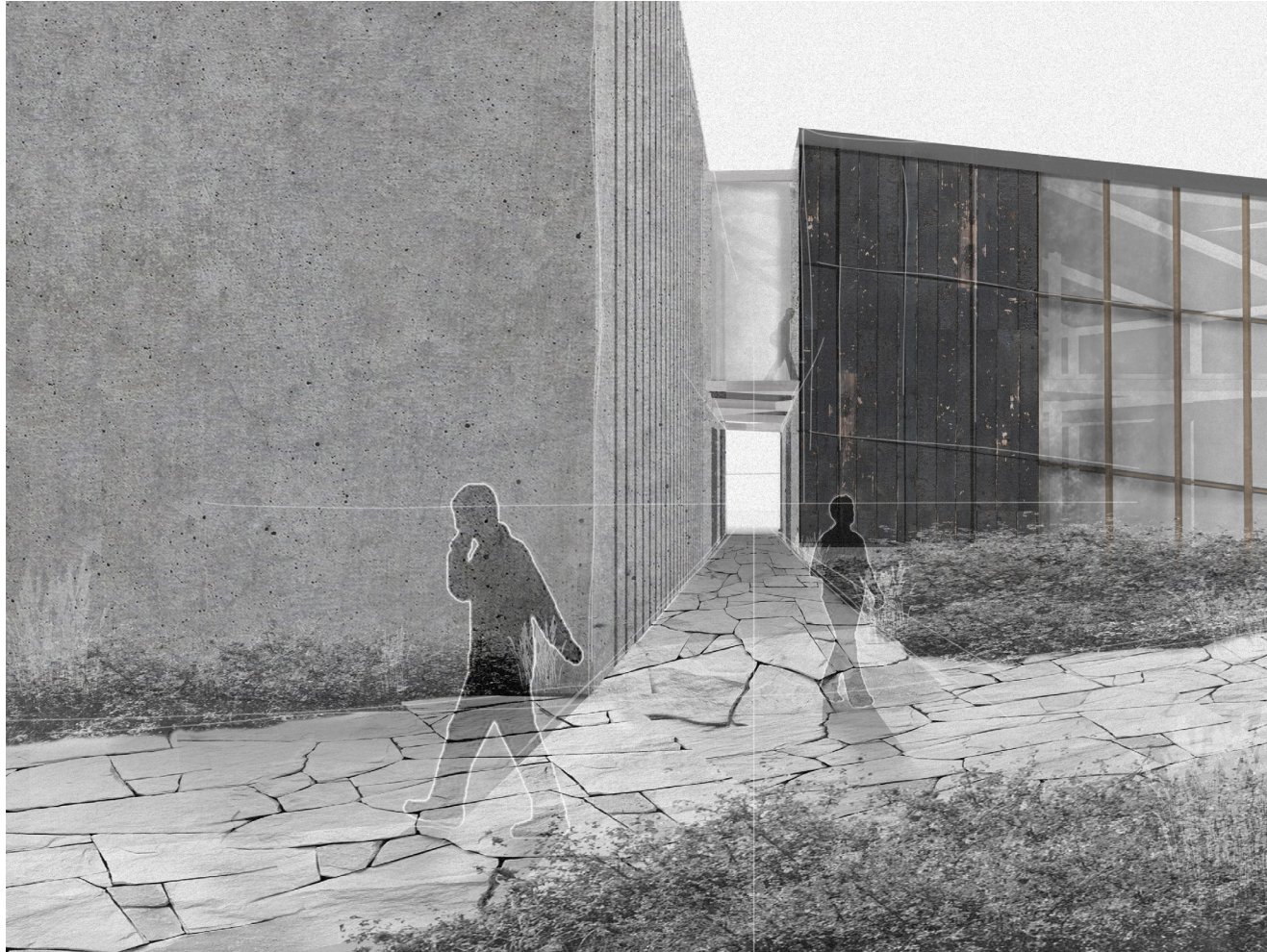

Shou Sugi Ban



**experience 3 / interior**

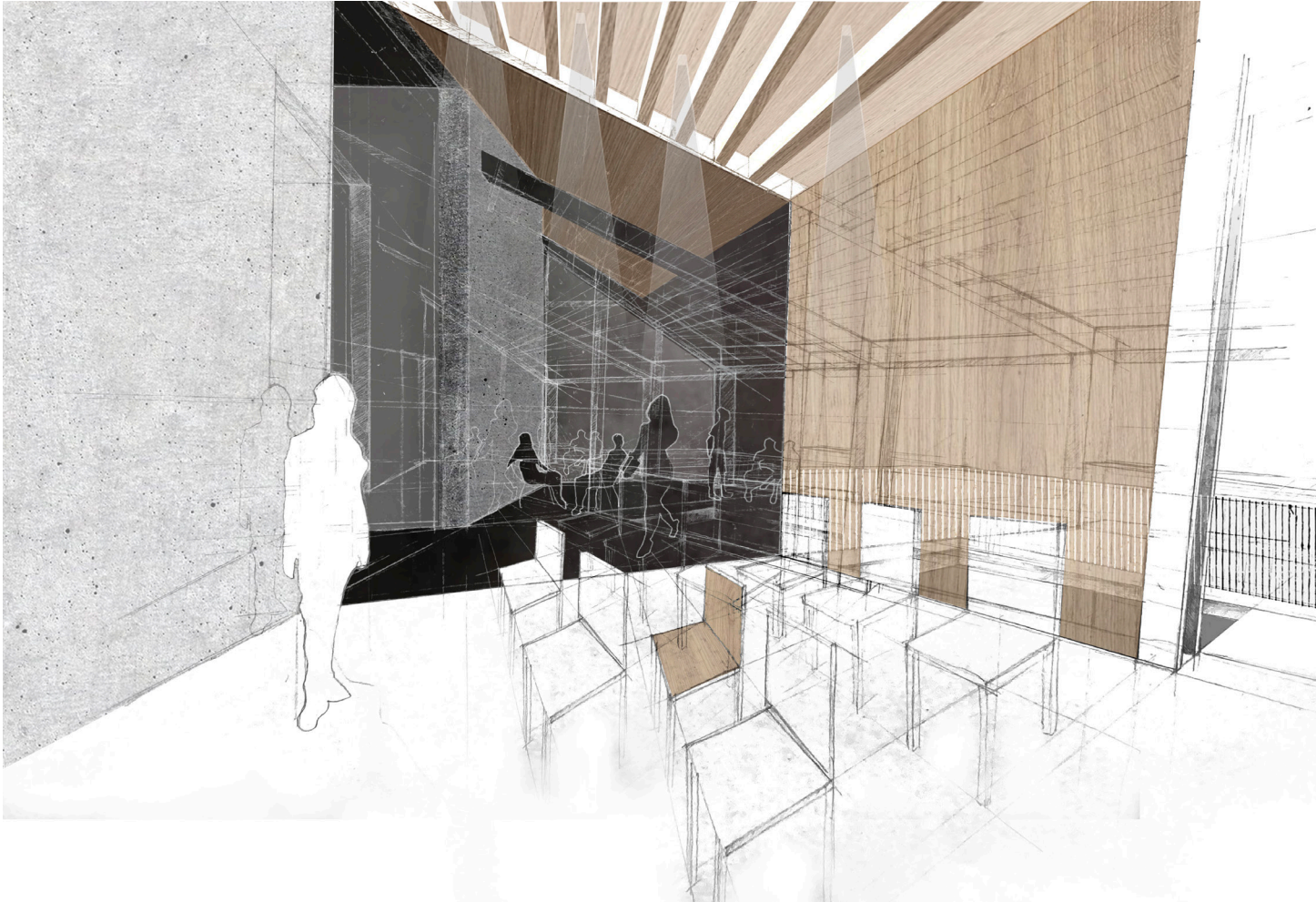



**explanation 2**  
*community center/office*

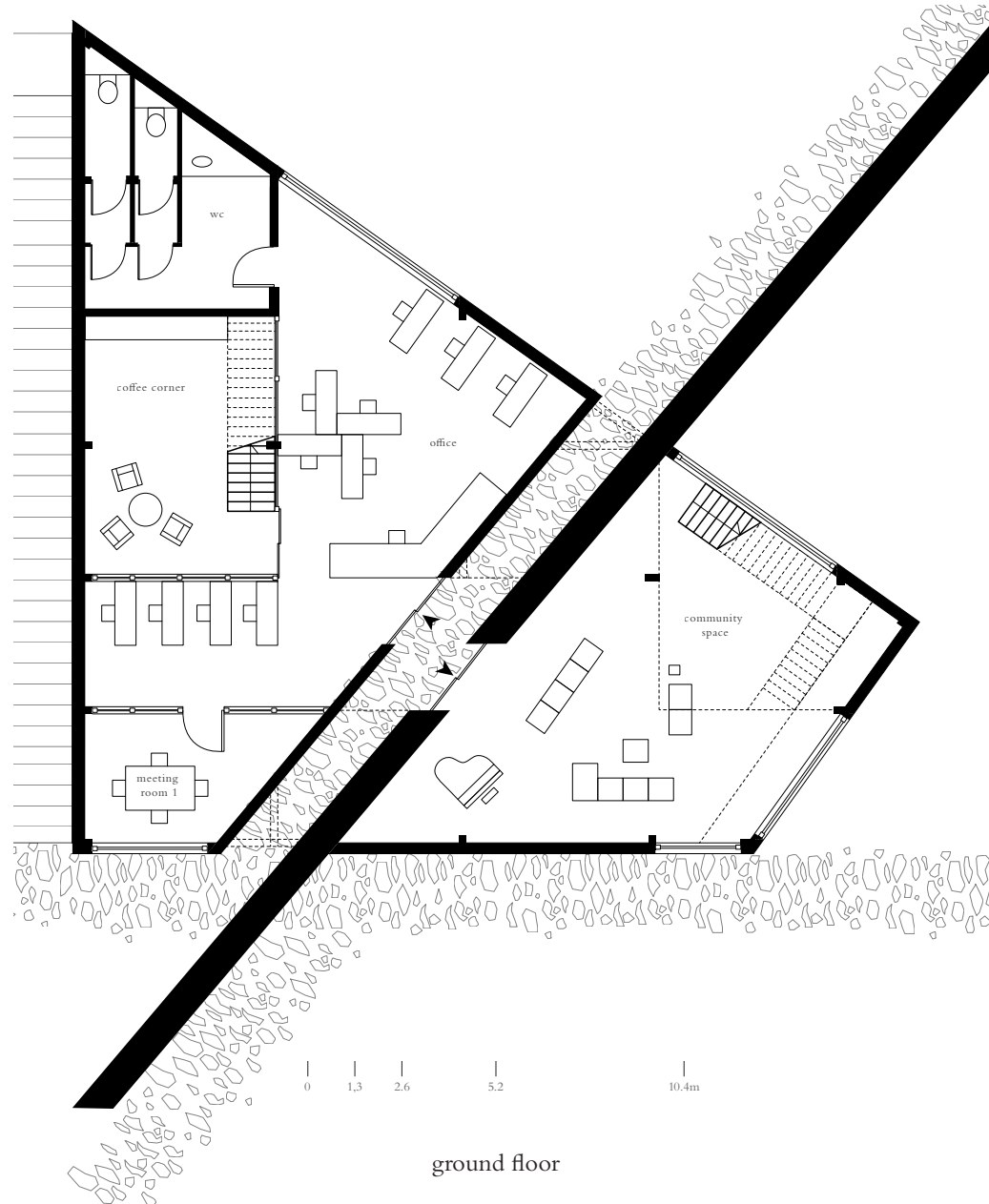

ground floor

**explanation 2**  
*community center/office*

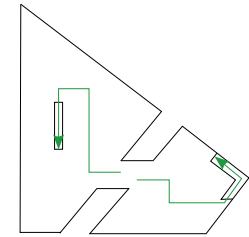
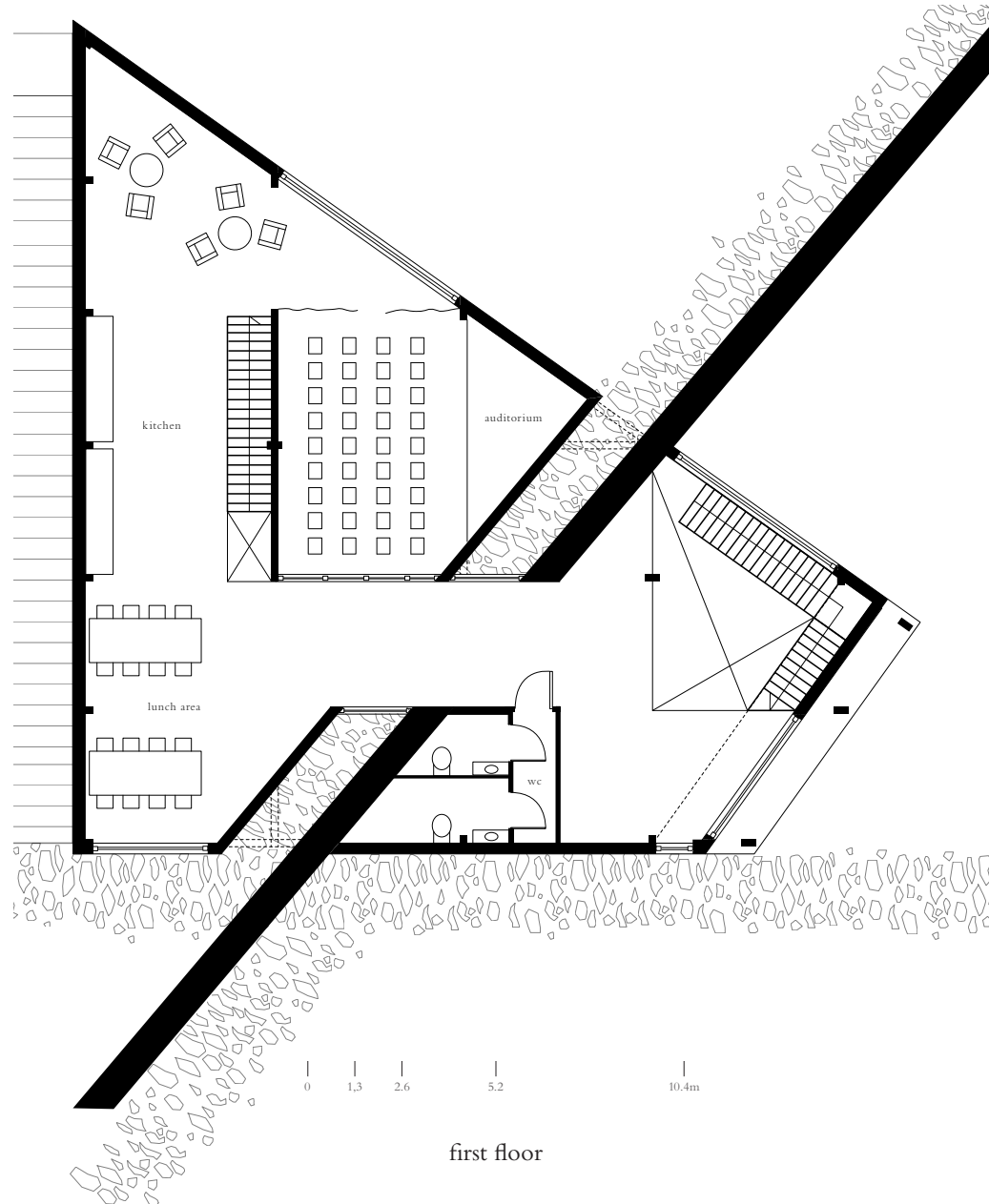

experience 3 / interior

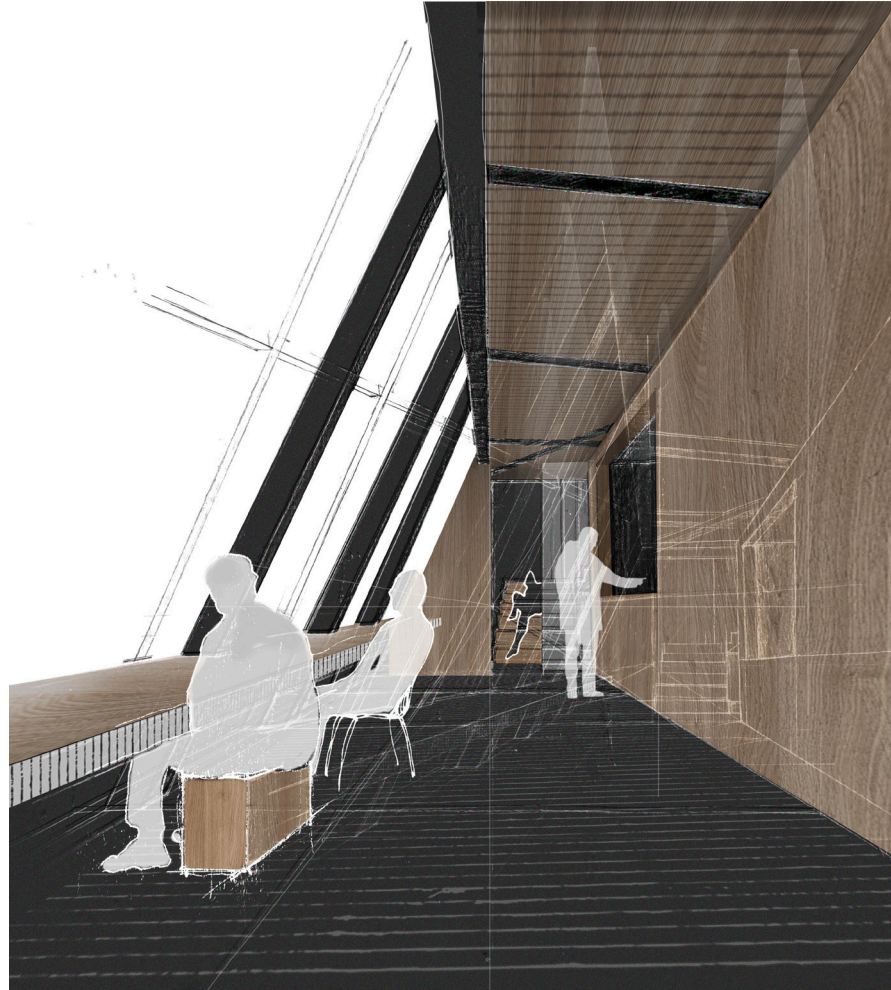

explanation 2  
shelter

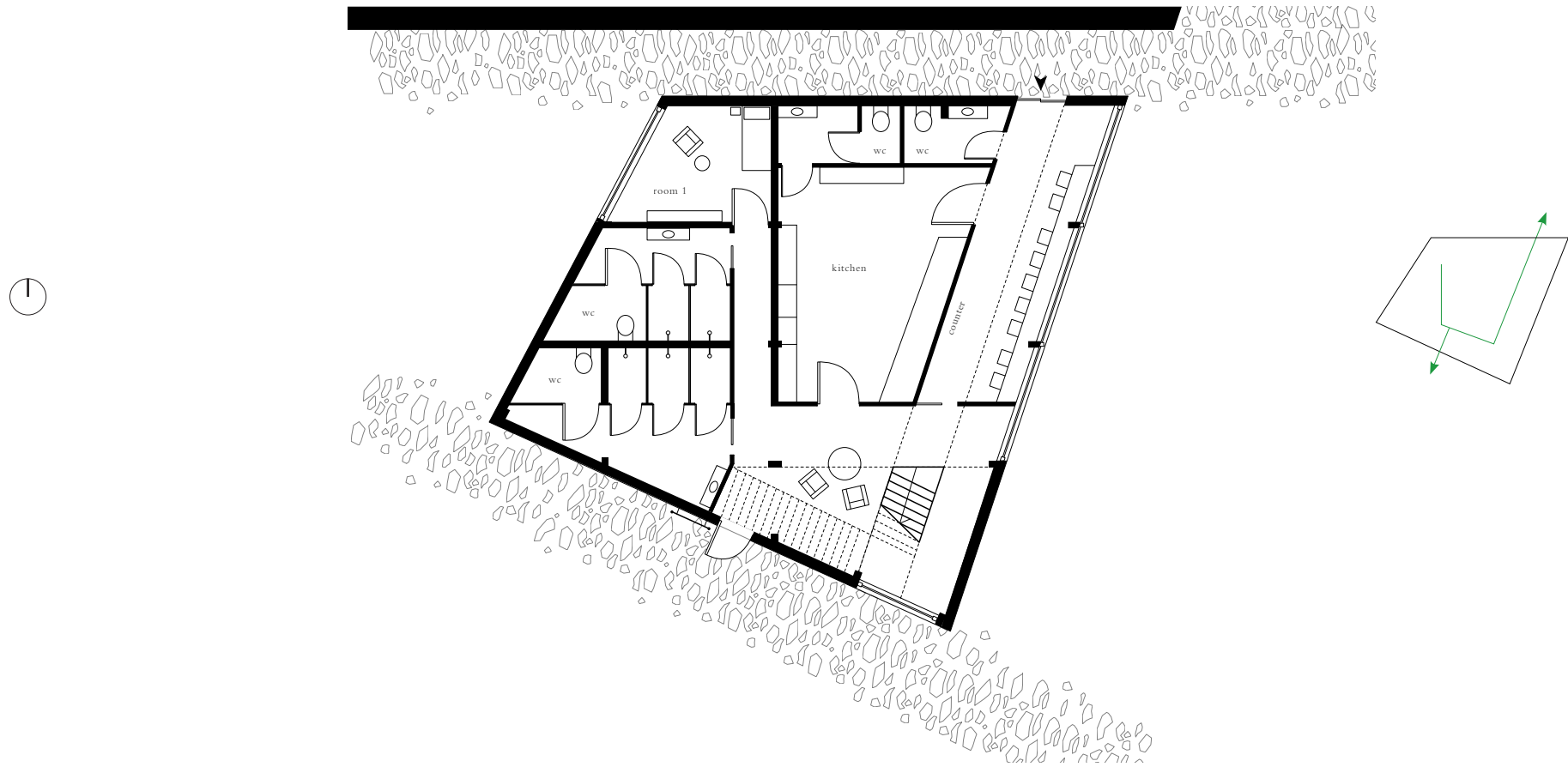

0 1.3 2.6 5.2 10.4m

ground floor

explanation 2  
shelter

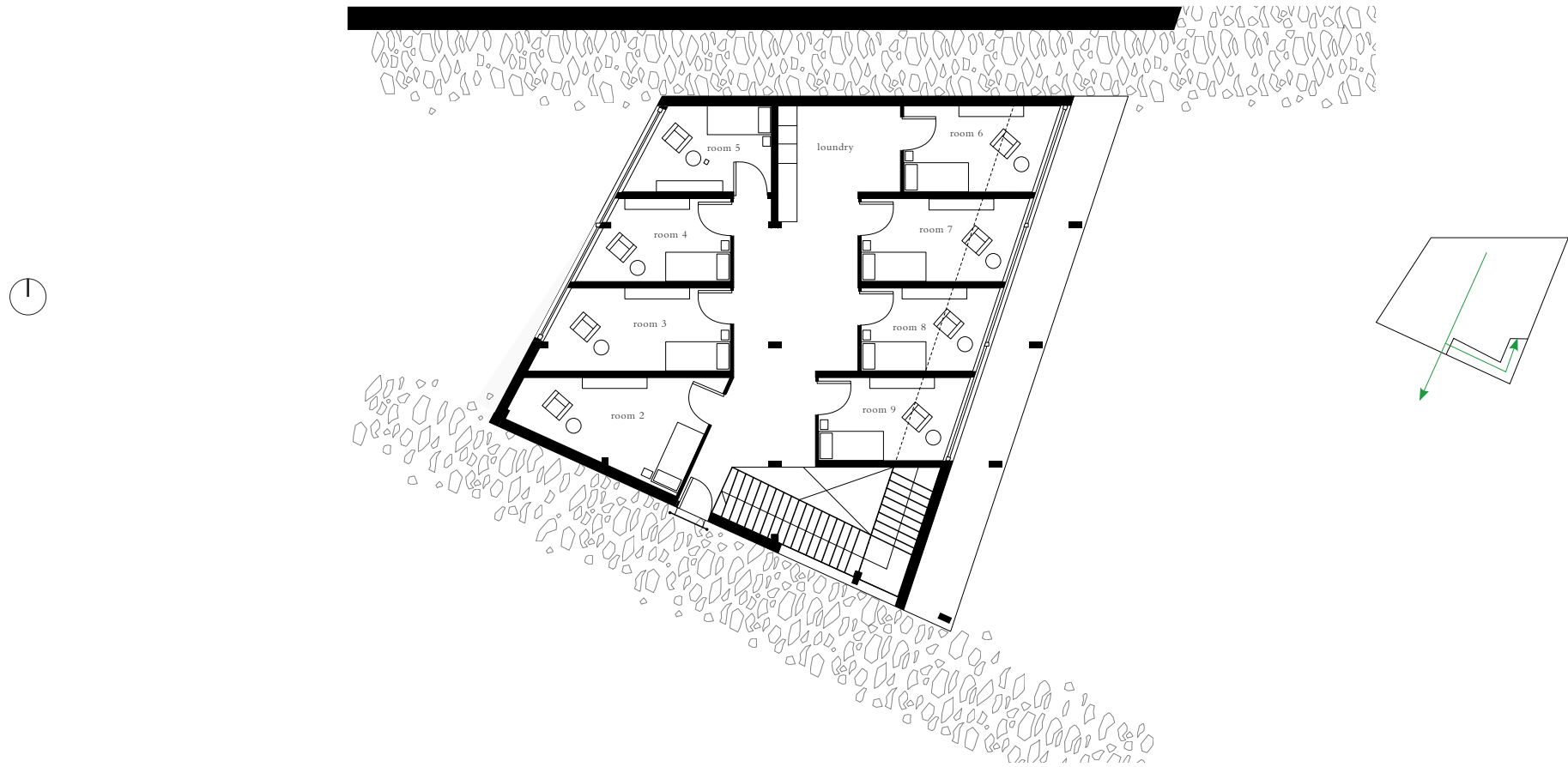

0 1.3 2.6 5.2 10.4m

first floor

**experience 4 / memorial**



*plaza*

**experience 4 / memorial**



*perimeter*

experience 4 / *memorial*



*underground*



# Masterplan

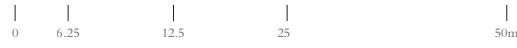
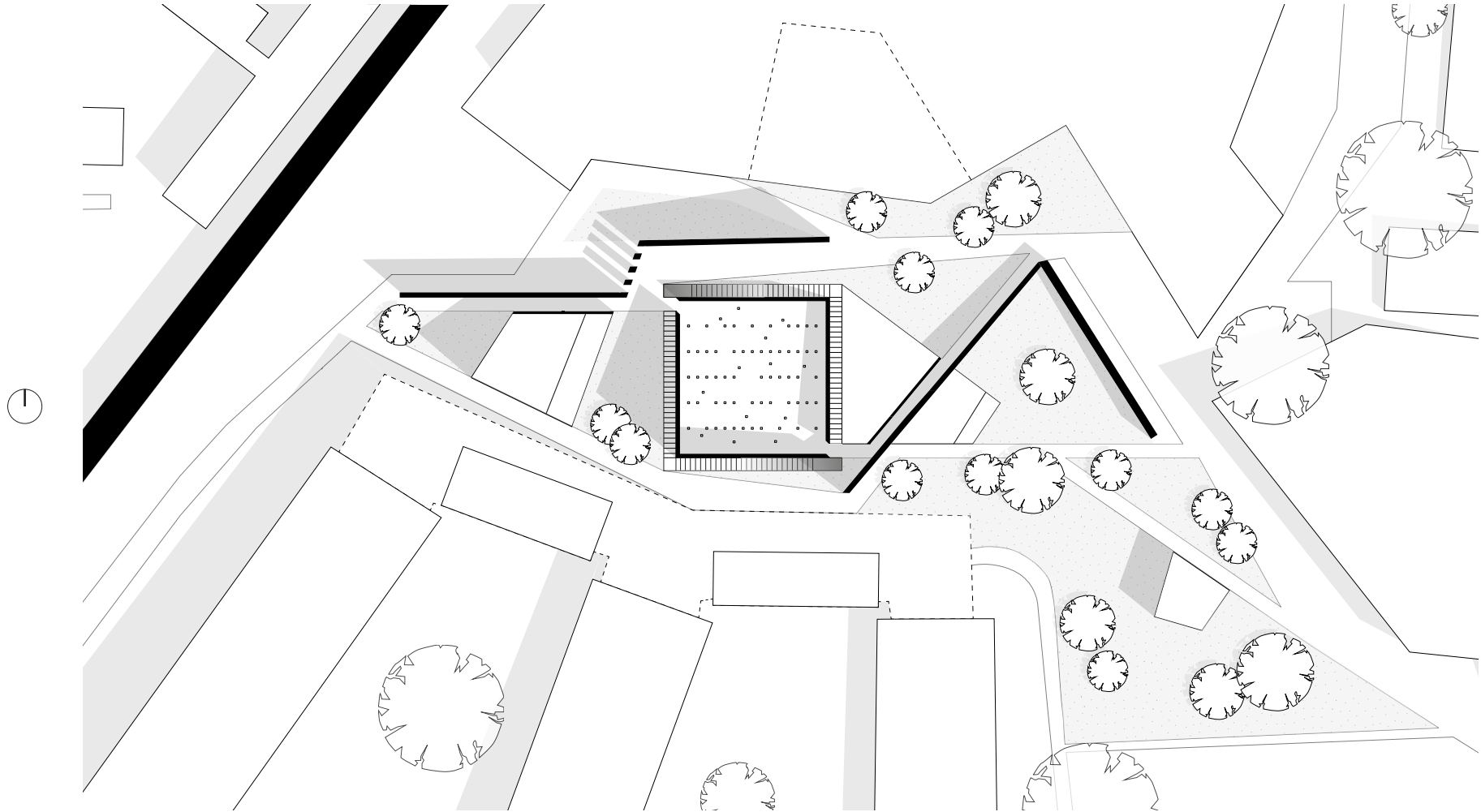

ground floor total

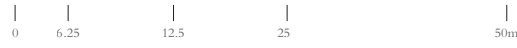
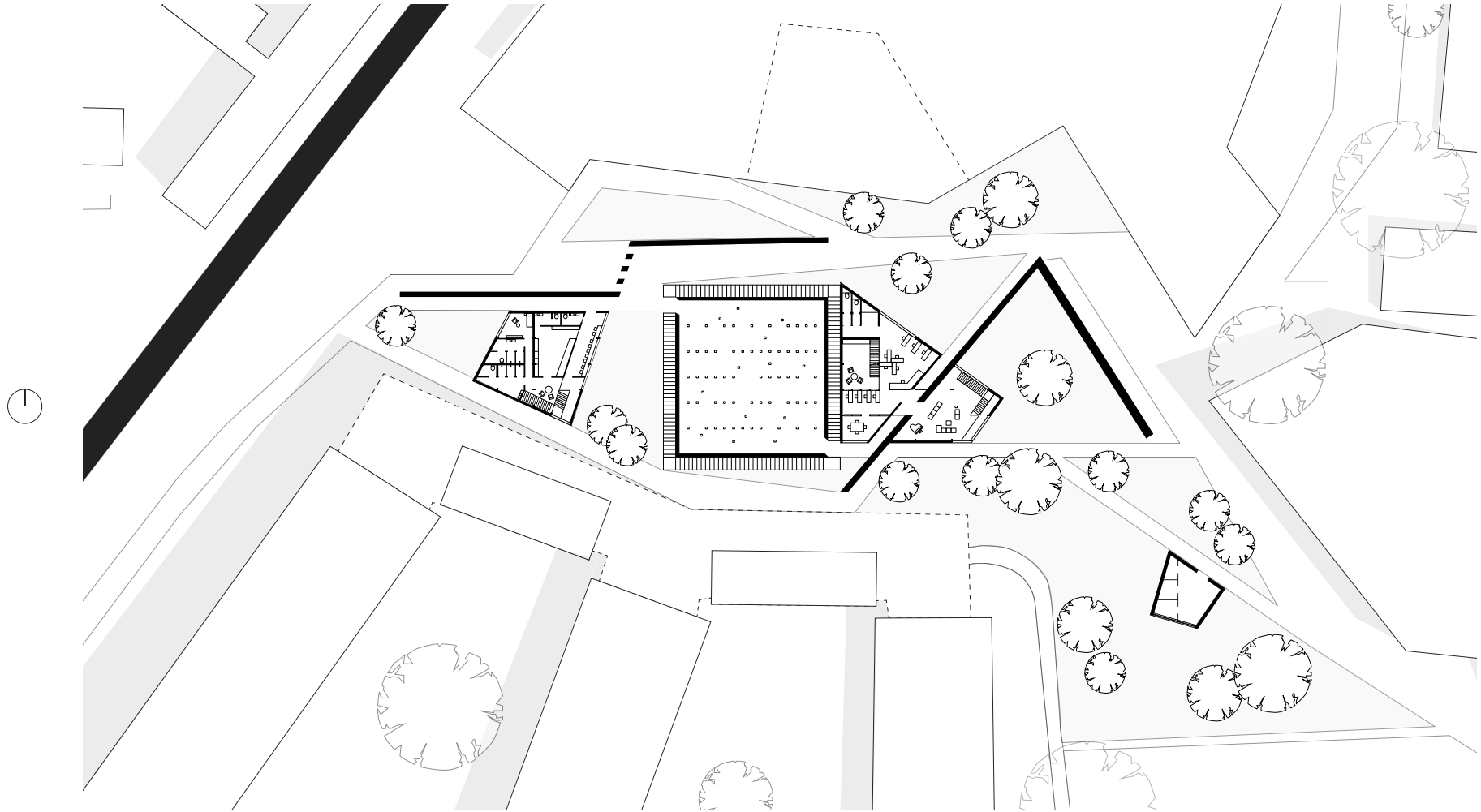

elevations

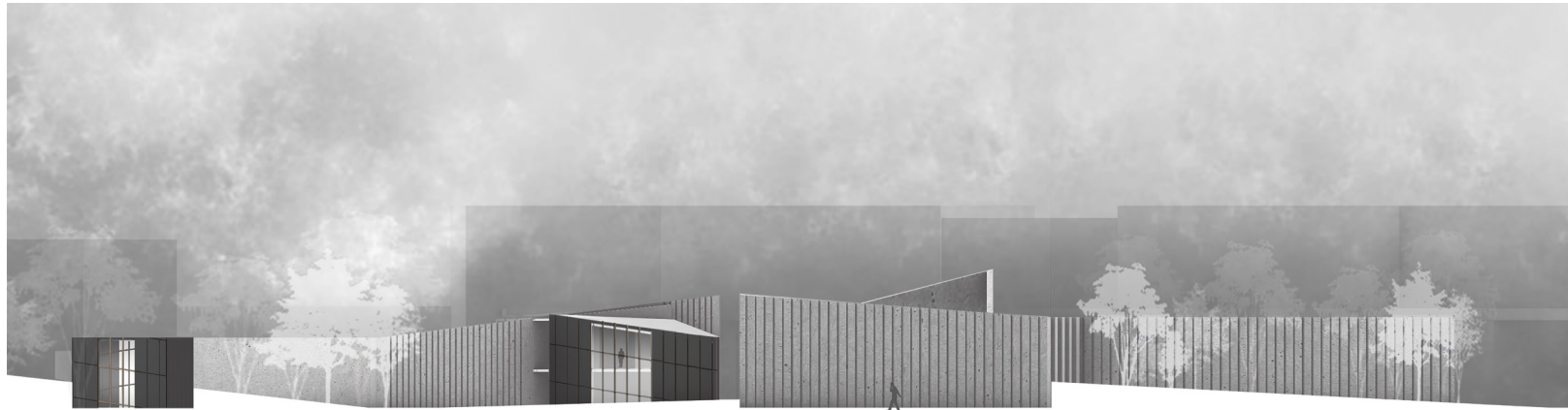

*North*

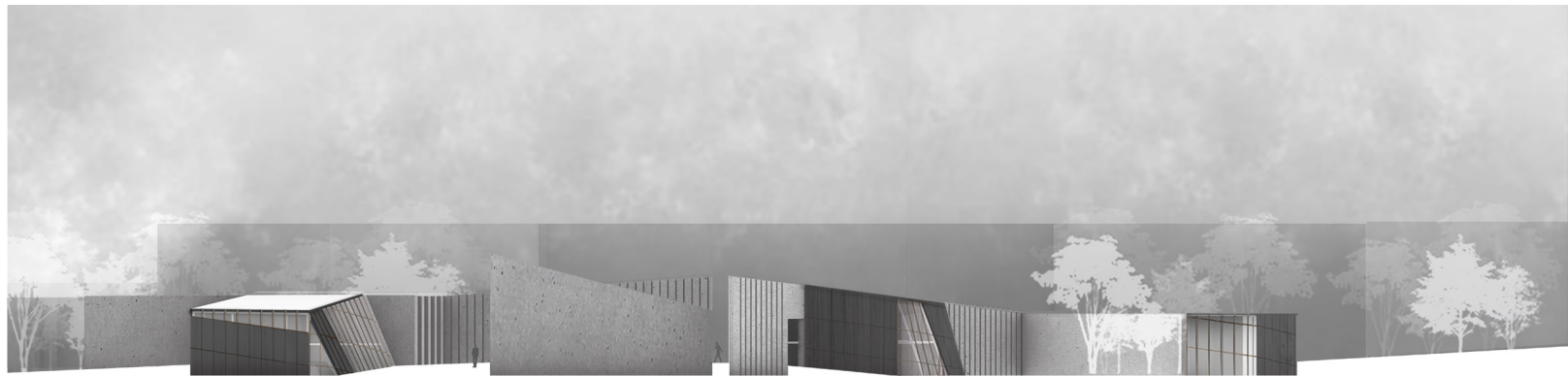

*South*

elevations

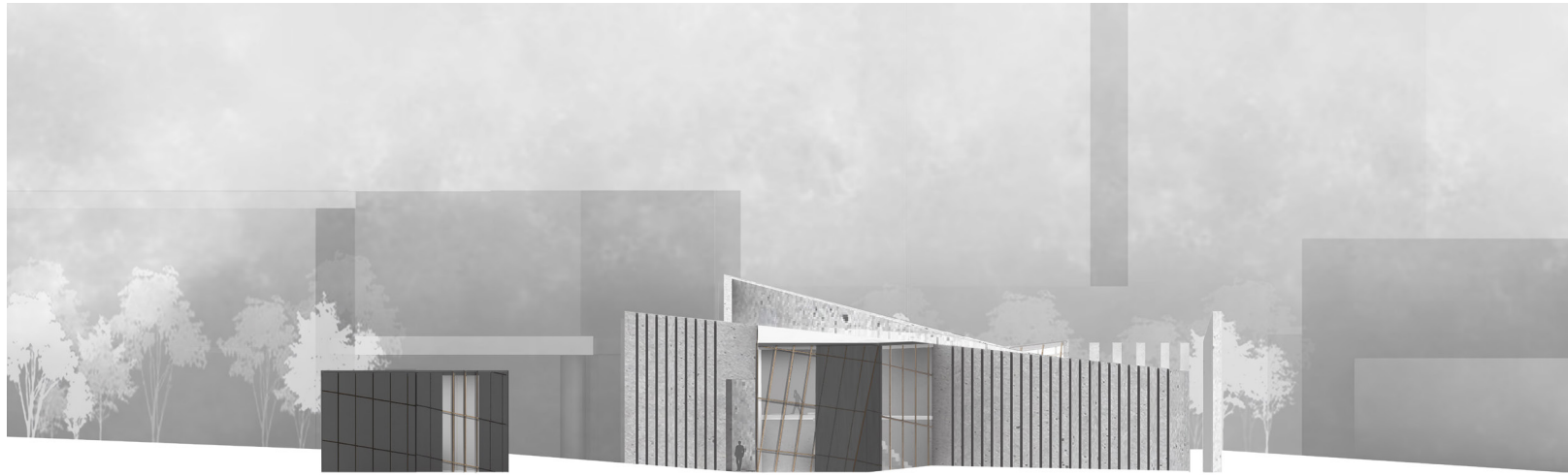

*East*

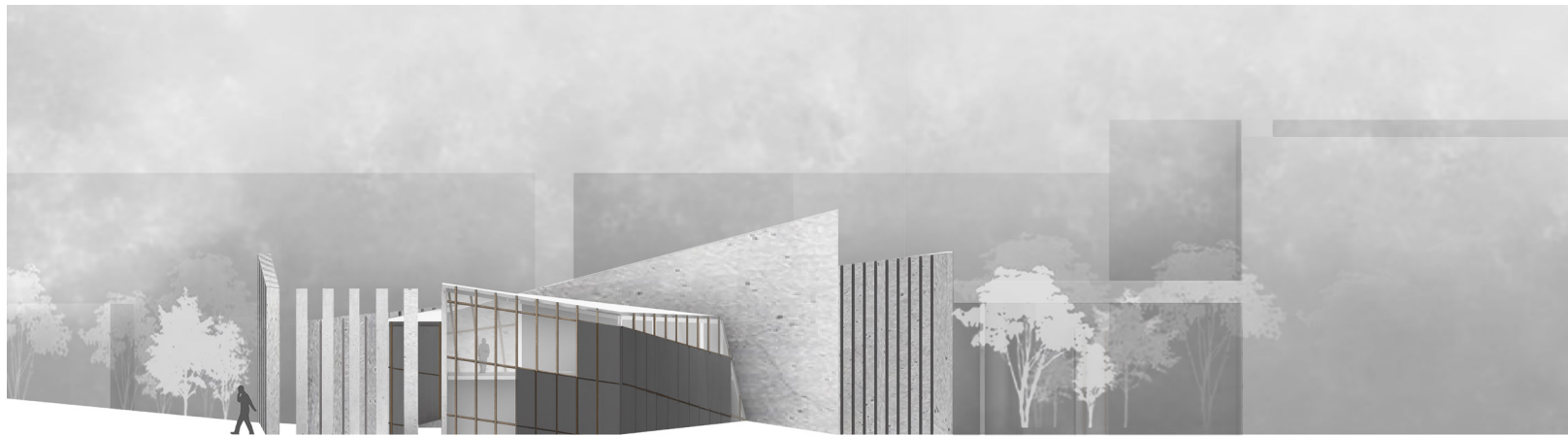

*West*

site sections

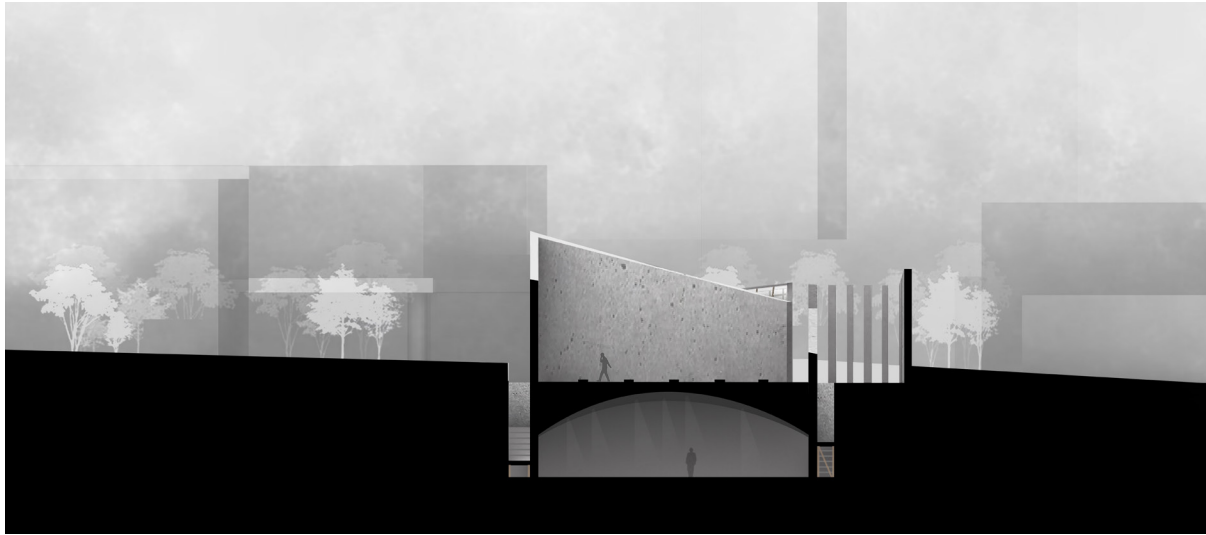

section AA

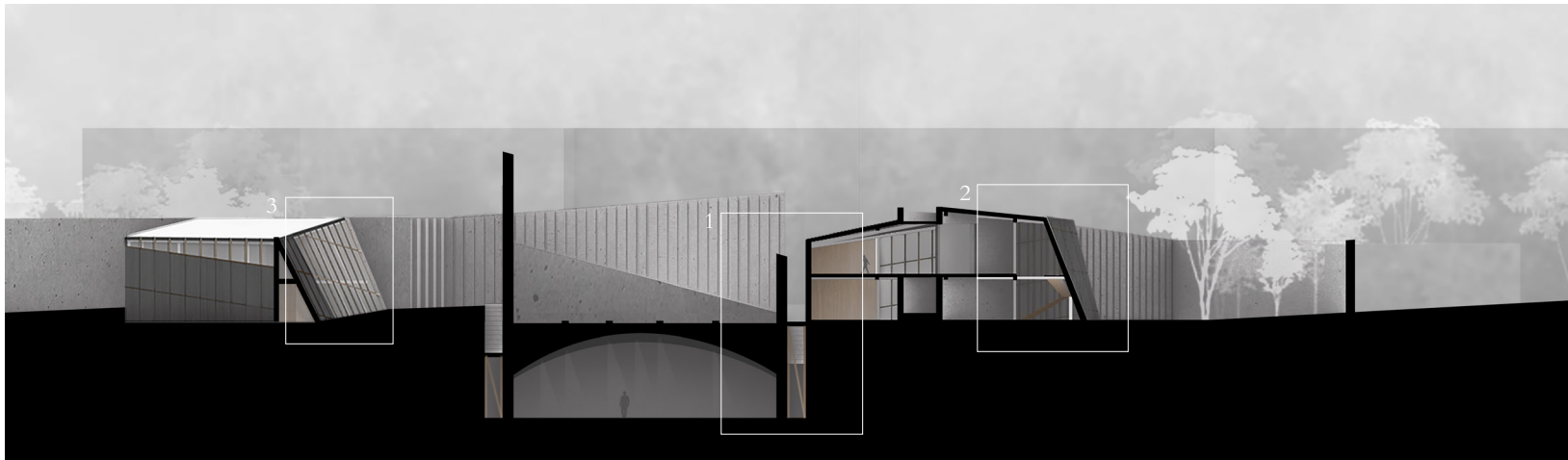
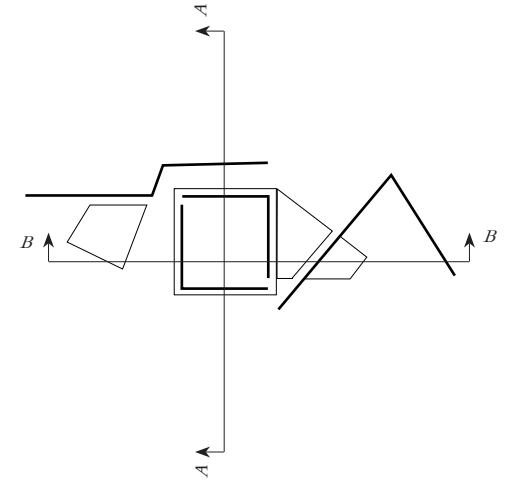

section BB

fragment 1

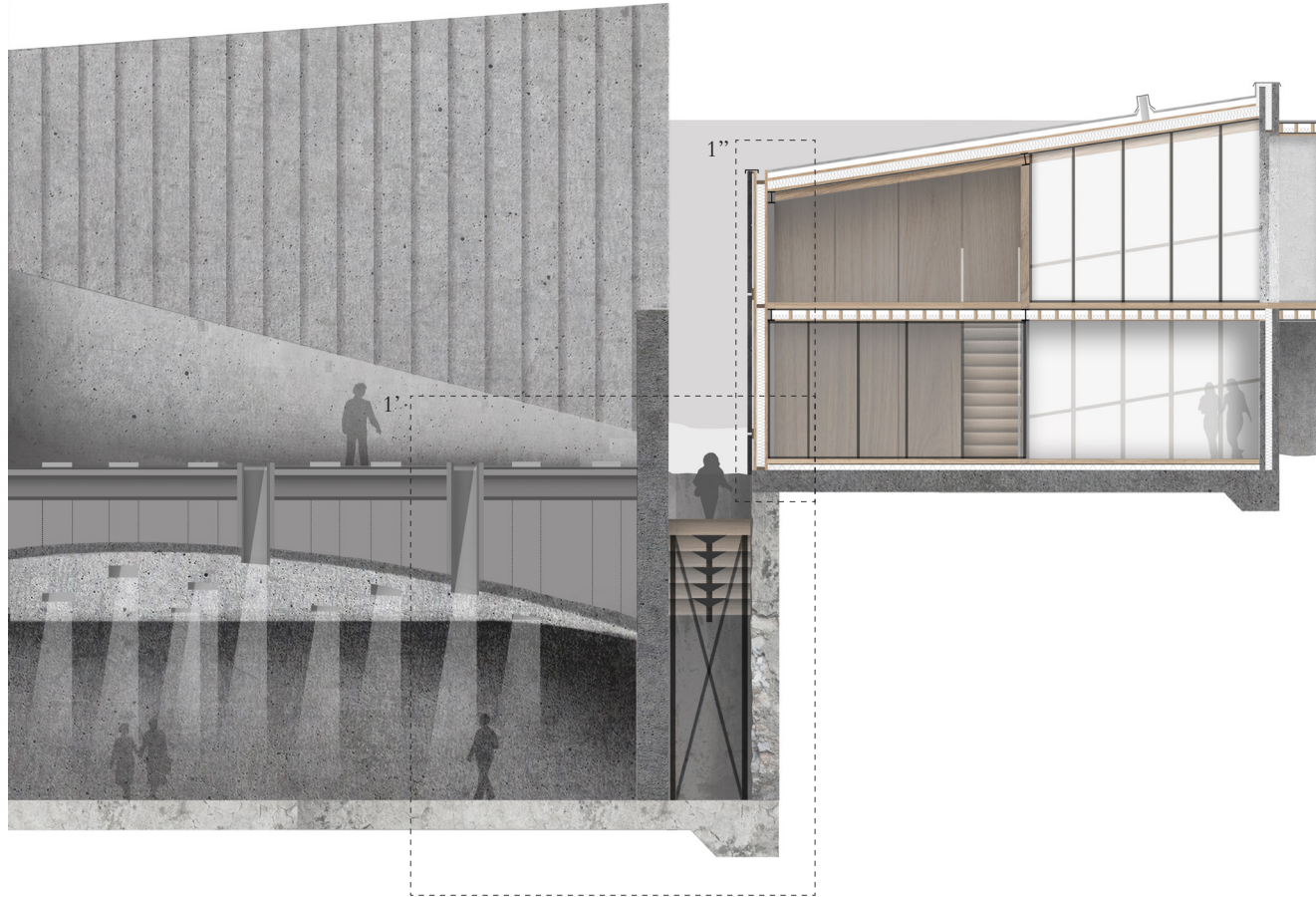

**fragment 1' / underground climate**

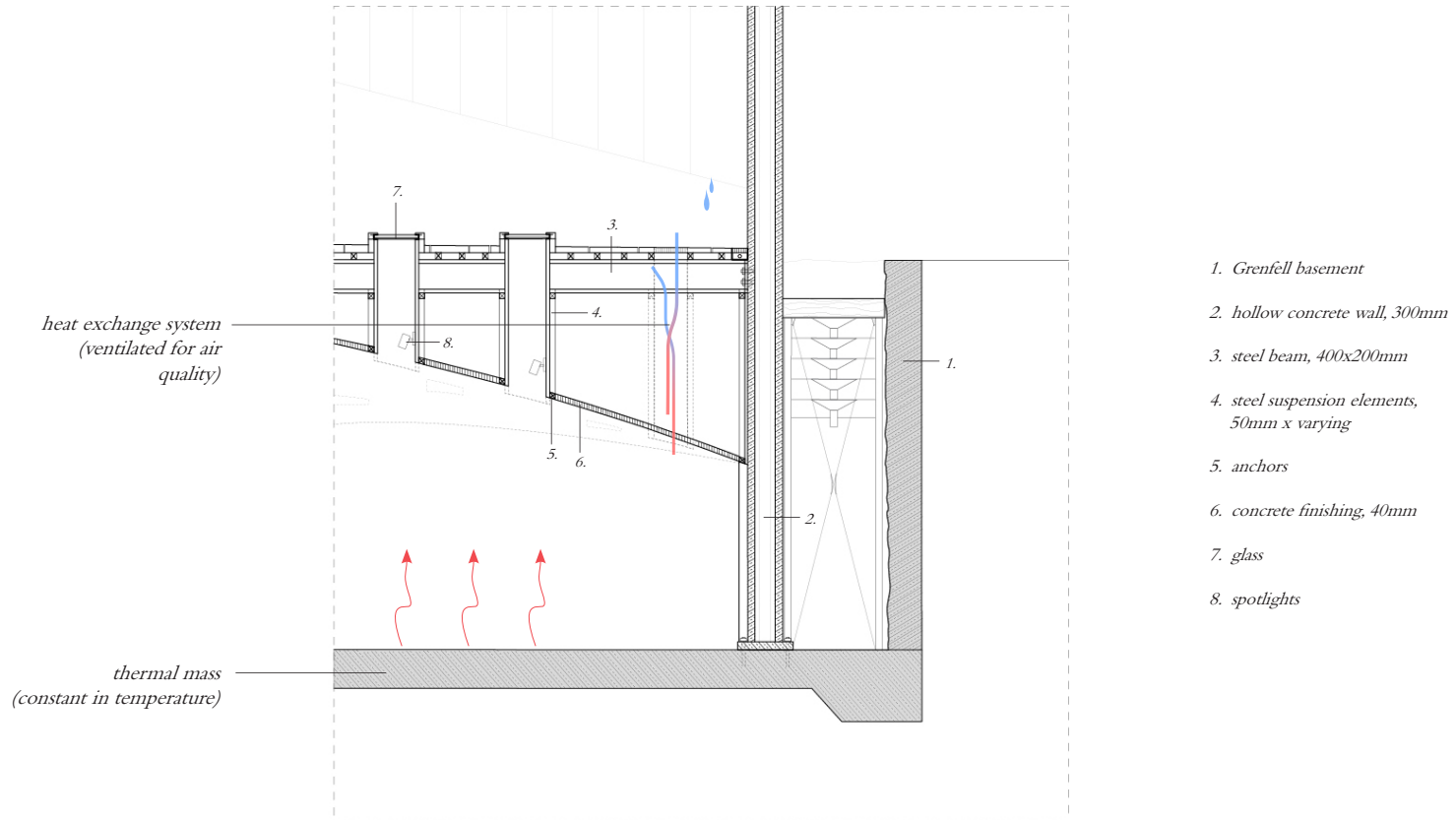

fragment 1'' / facade

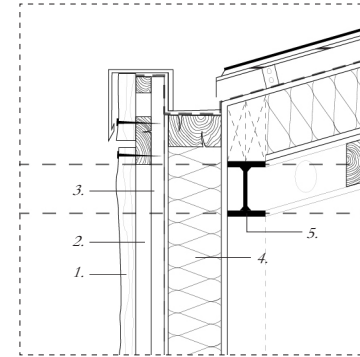
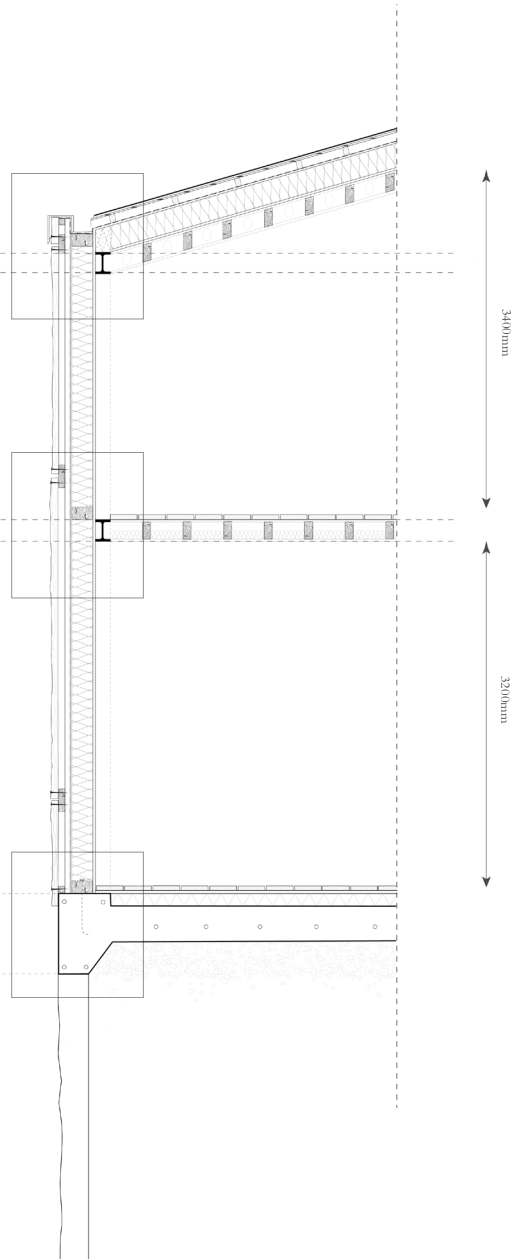
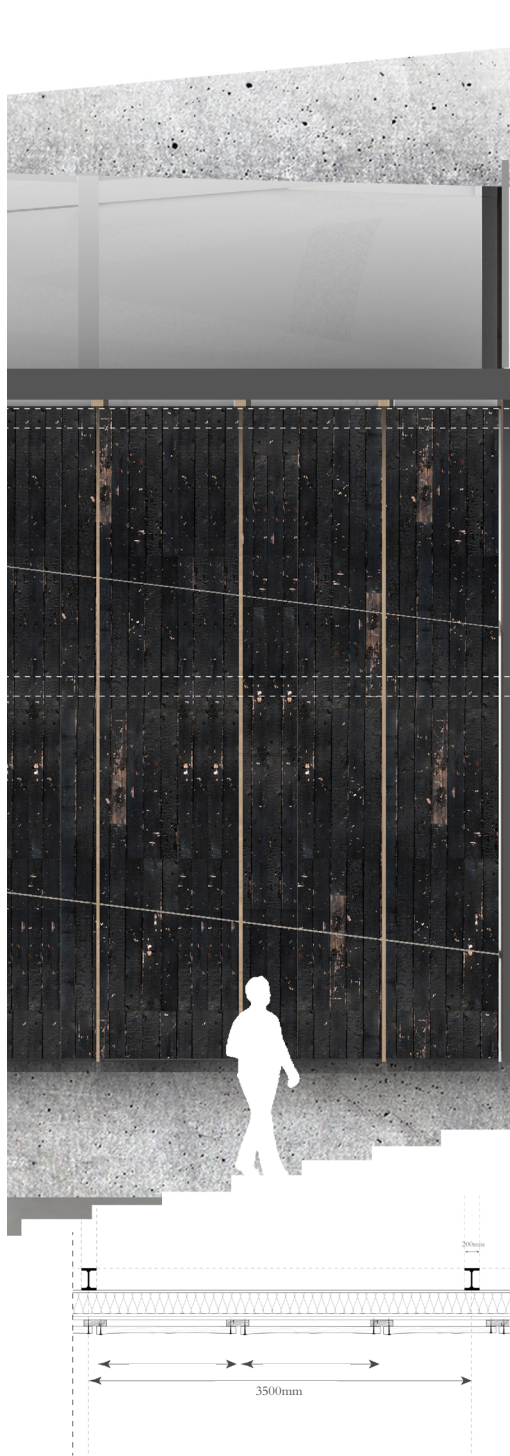

- 1. facade cladding (Sou Sugi Ban), 40mm
- 2. horizontal battens, 40x100mm
- 3. vertical battens, 40x100mm
- 4. thermal insulation, 250mm
- 5. steel beam, 400x200mm

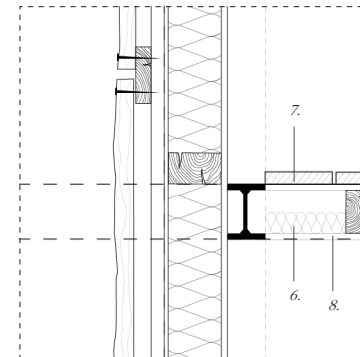

- 6. acoustic insulation, 180mm
- 7. floor finishing: treated plywood, 400x2600mm
- 8. ceiling: timber boards, 1300x2600mm

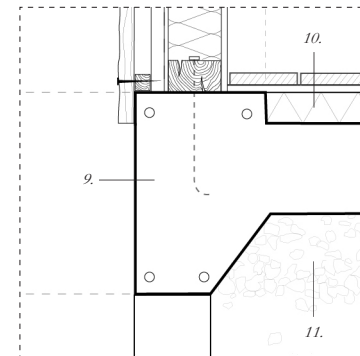

- 9. concrete foundation
- 10. thermal insulation: mineral wool, 150mm
- 11. gravel



**concrete wall / cutting the structure**

*timber facade- ceiling*

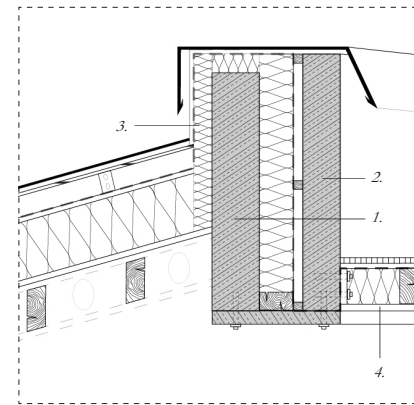
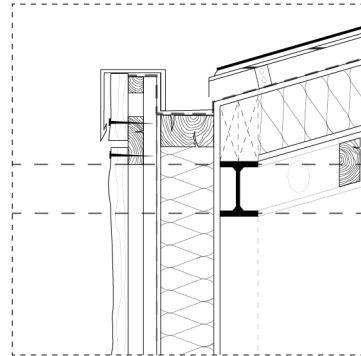

*ceiling - concrete wall*

1. concrete wall: structural, 300mm
2. concrete finishing, 150mm
3. thermal insulation, 80mm
4. steel beam, 200x400mm with insulation inside

fragment 2

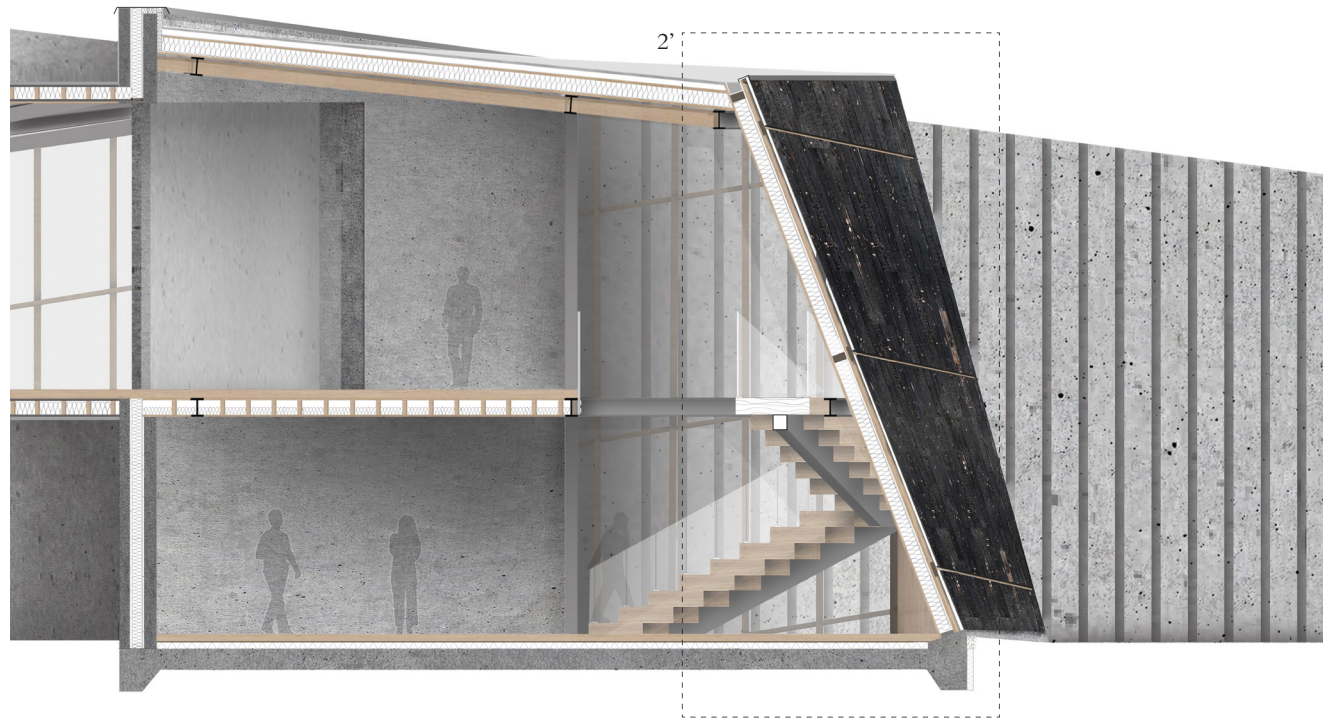

**fragment 2' / facade**

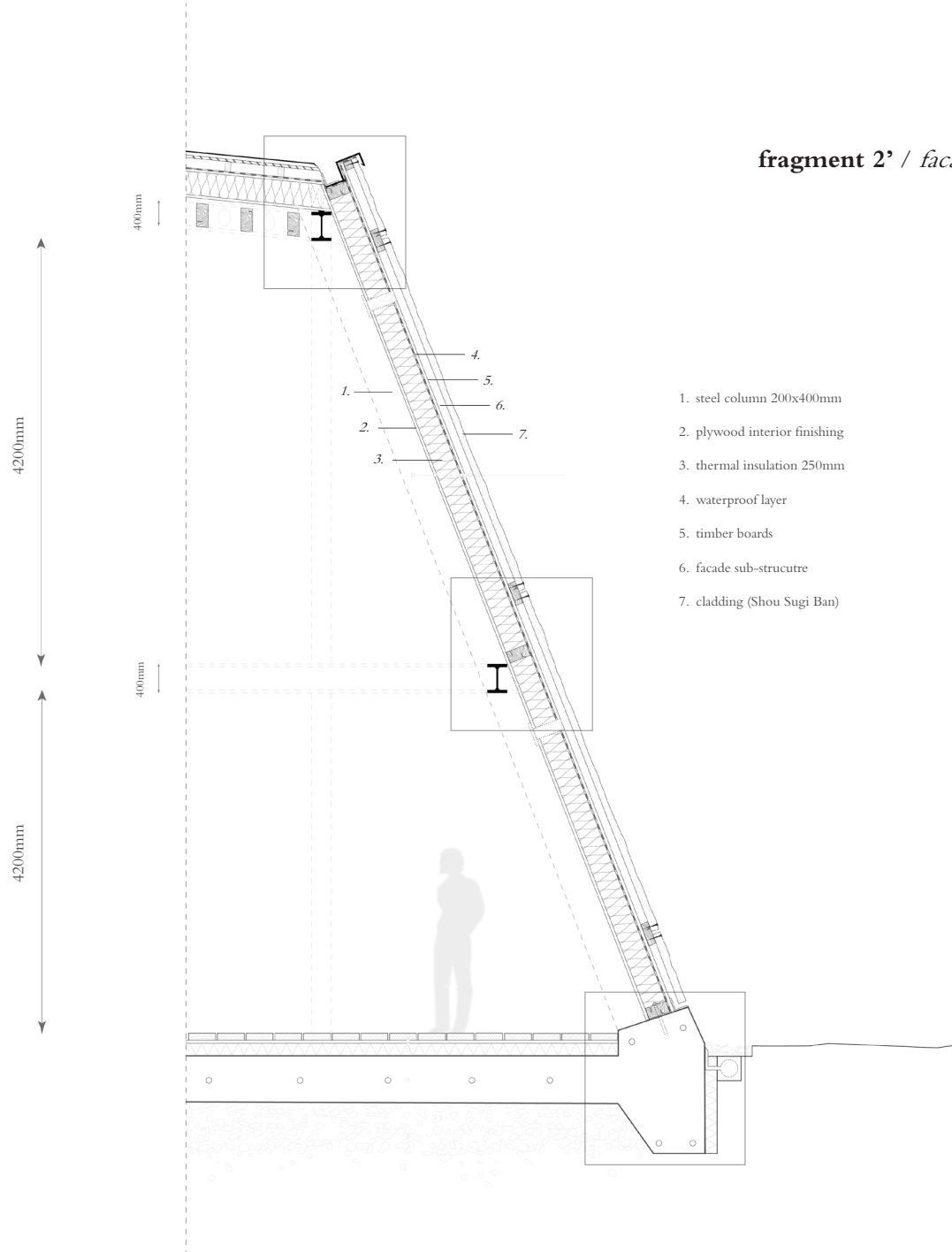

- 1. steel column 200x400mm
- 2. plywood interior finishing
- 3. thermal insulation 250mm
- 4. waterproof layer
- 5. timber boards
- 6. facade sub-structure
- 7. cladding (Shou Sugi Ban)

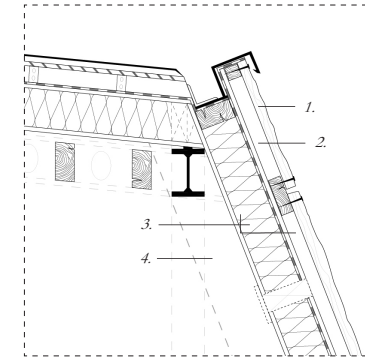

- 1. facade cladding (Sou Sugi Ban), 40mm
- 2. horizontal & vert. battens, 40x100mm
- 3. thermal insulation, 250mm
- 4. steel beam, 400x200mm

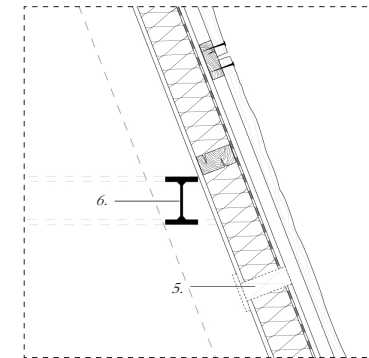

- 5. air inlet
- 6. steel beam, 200x400mm

- 7. concrete foundation
- 8. gravel
- 9. drainage

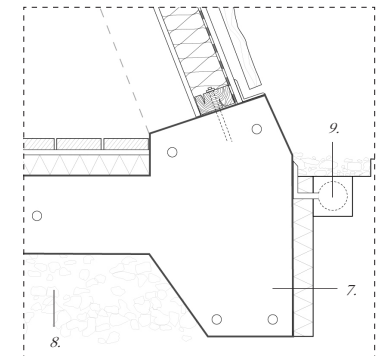

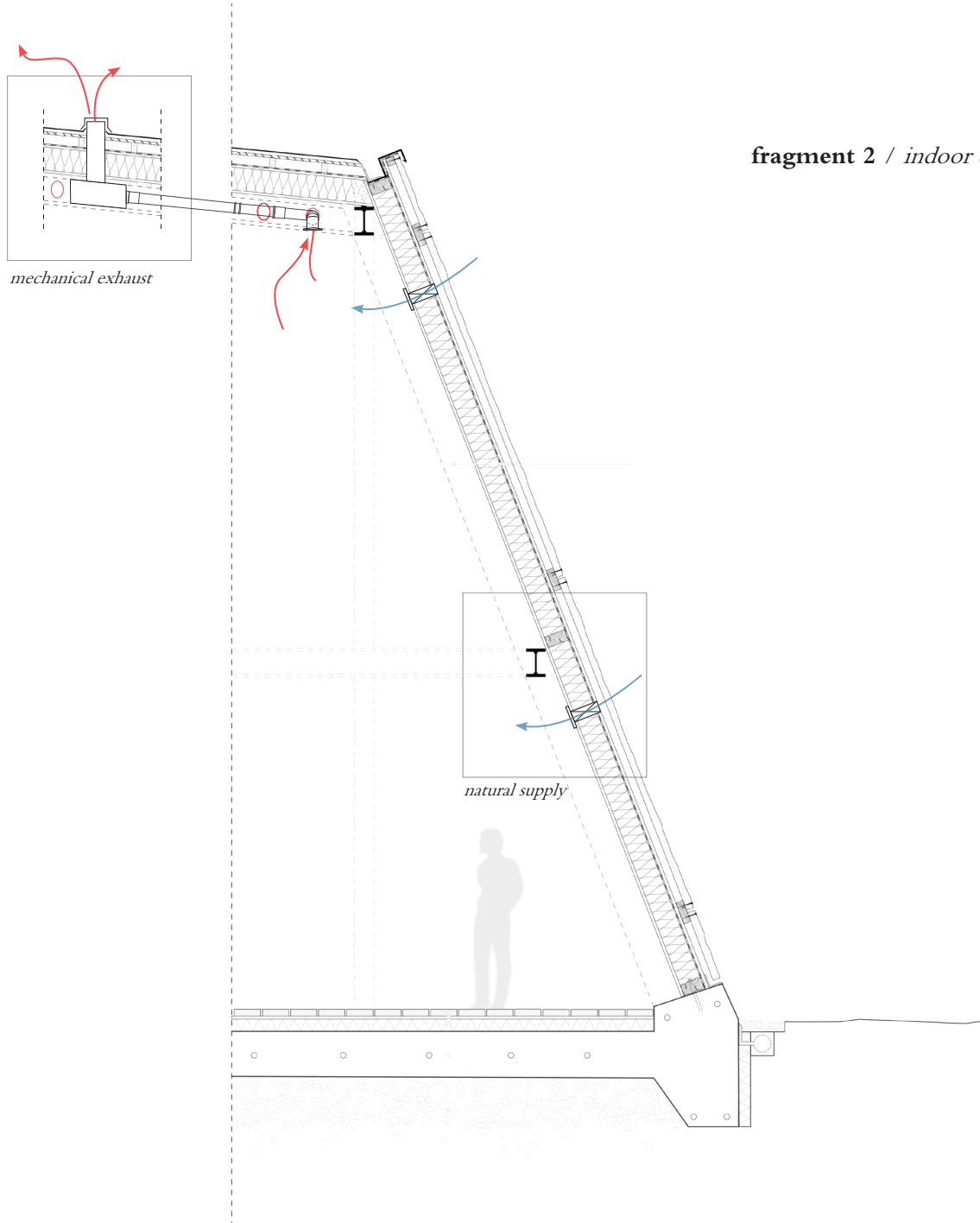

**fragment 2 / indoor climate**

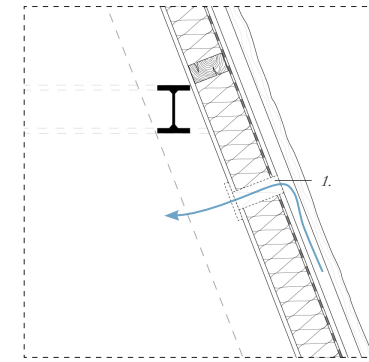

*1. air inlet: controlled amount of air coming in*

fragment 2 / facade (opening)

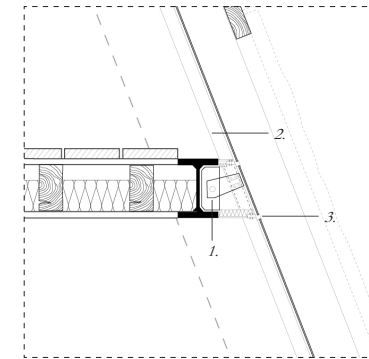
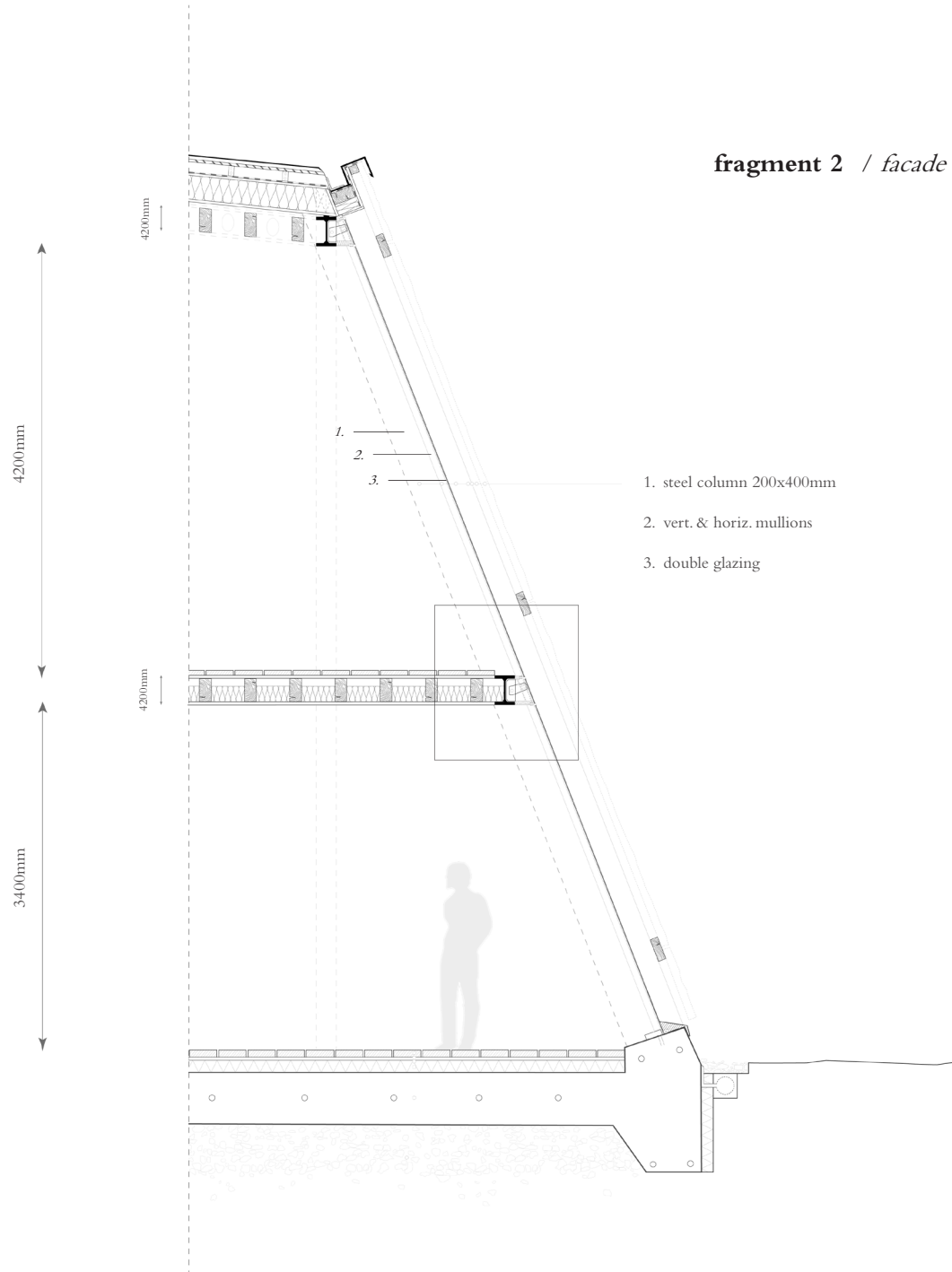

- 1. welded connection
- 2. curtain wall
- 3. anchors

**fragment 3 / shelter**

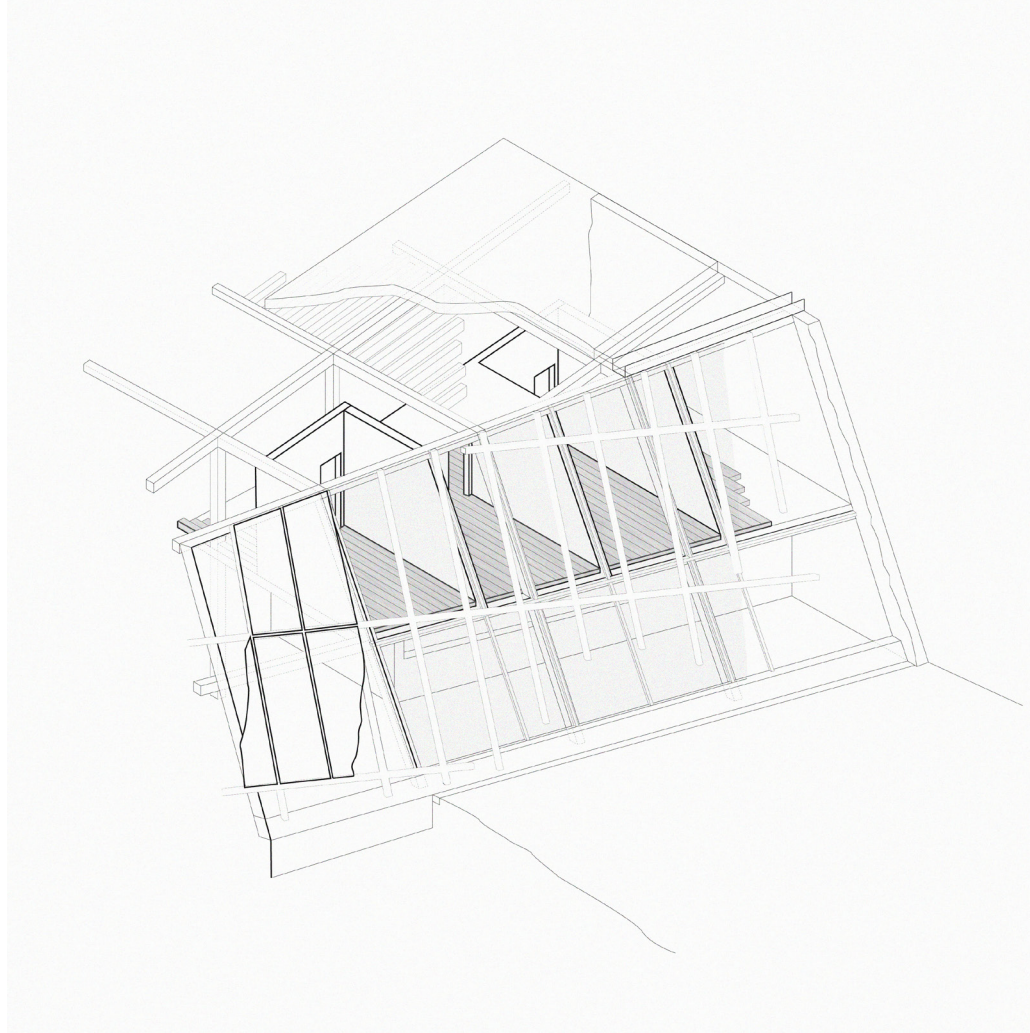

**fragment 3 / façade**

1. steel column 200x400mm
2. shutters
3. vert. & horiz. mullions, 100x50mm
4. double glazing

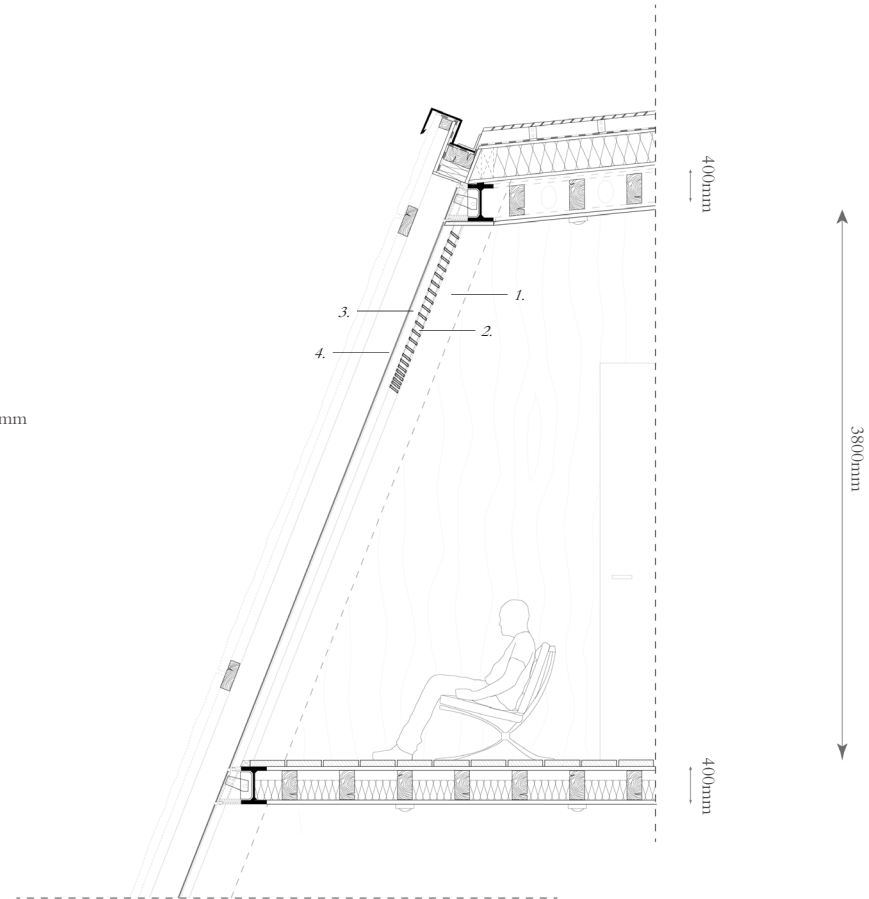

structural grid / Grenfell grid

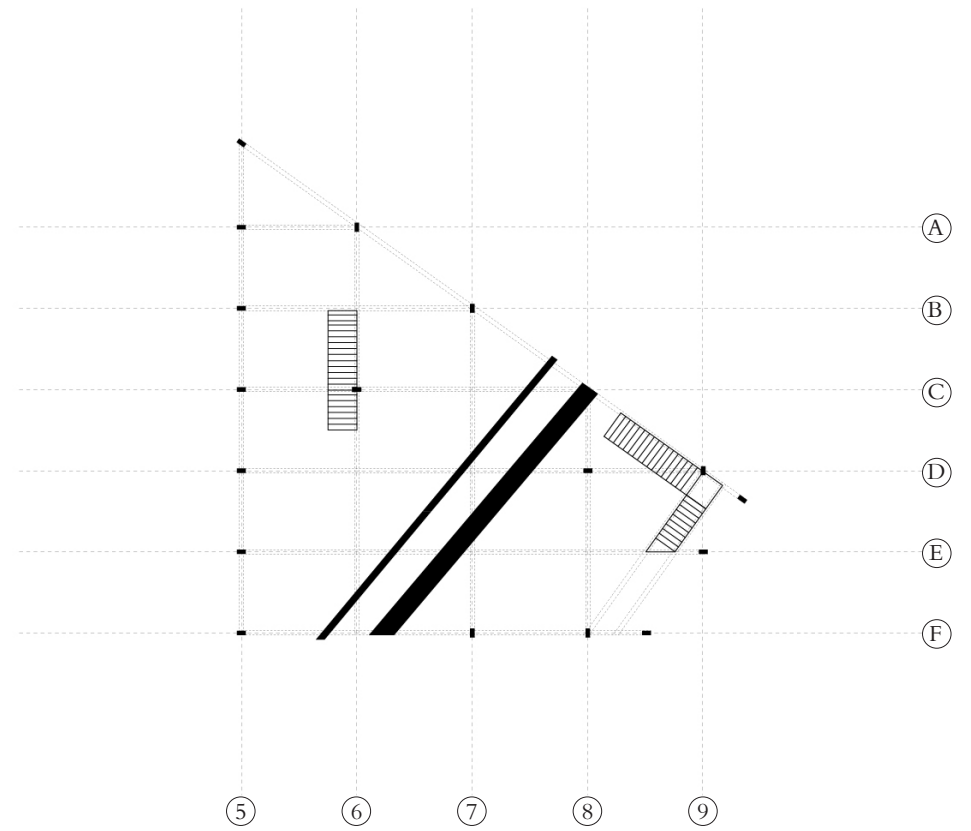
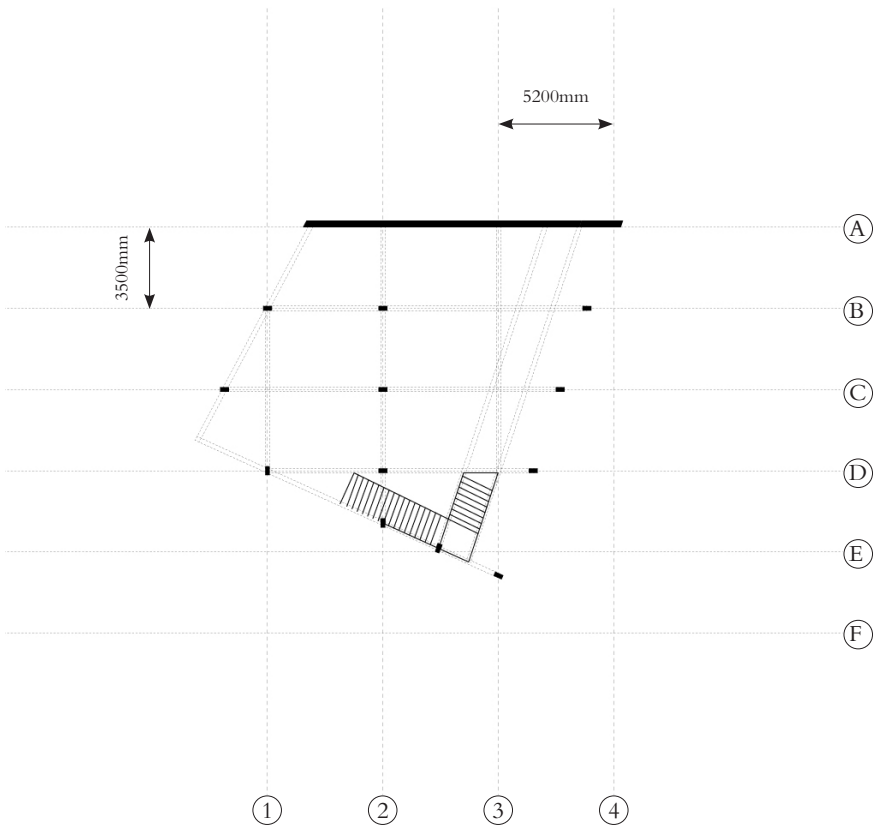

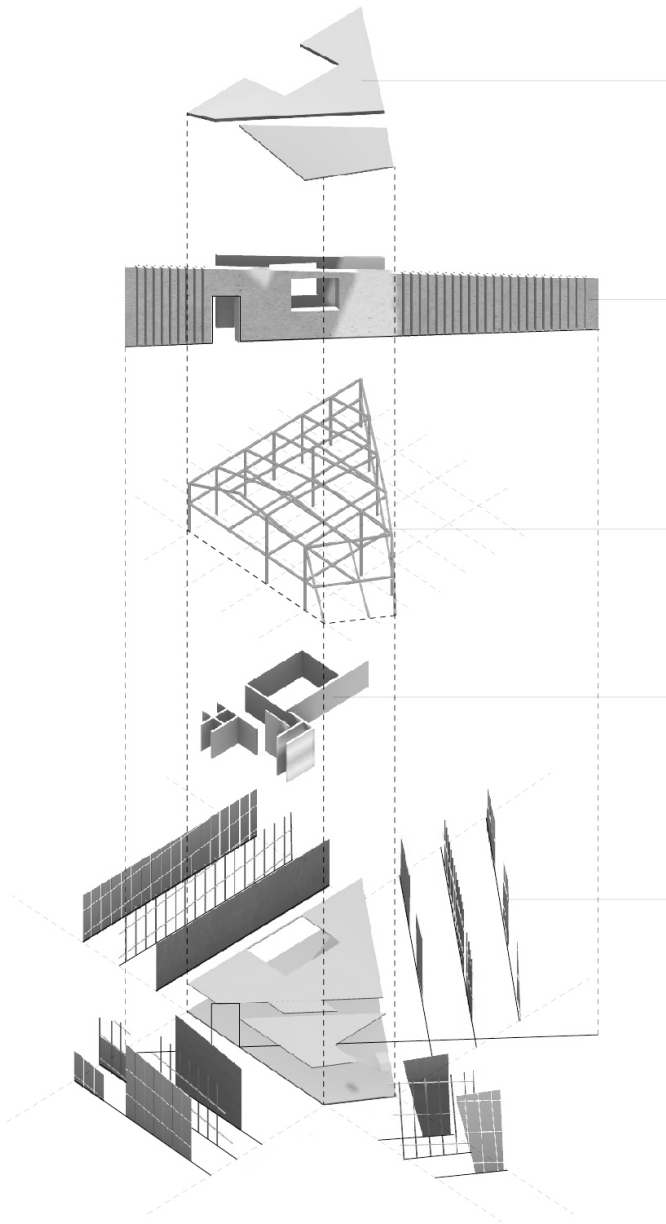

**construction** / *building order*

roof ⑥

concrete wall (structural) ②

steel structure ③

interior walls (timber) ④

facade composition ⑤  
- sandwich panel

- sub-structure ⑦  
- cladding (Shou Sugi Ban)  
- curtain wall (openings)

foundation ①

system fragment



overview

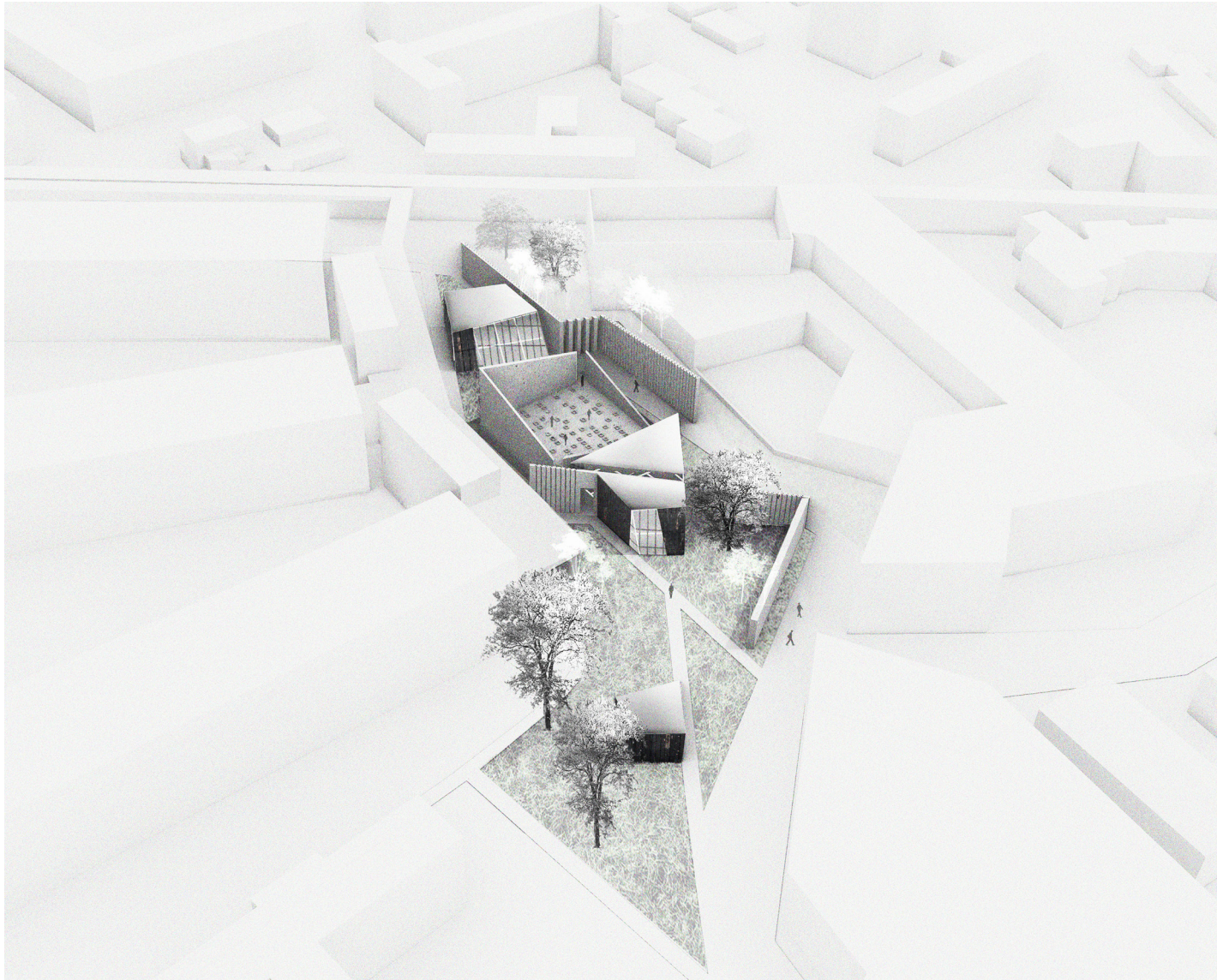

Thank you !