



Delft University of Technology

Design of a New Ship Propulsion System Fundamentals course

de Vos, P

Publication date

2015

Document Version

Accepted author manuscript

Published in

Proceedings 12th International Marine Design Conference (IMDC) 2015

Citation (APA)

de Vos, P. (2015). Design of a New Ship Propulsion System Fundamentals course. In A. Papanikolaou, H. Yamato, & A. et (Eds.), *Proceedings 12th International Marine Design Conference (IMDC) 2015* (pp. 281-293). JSNAOE.

Important note

To cite this publication, please use the final published version (if applicable). Please check the document version above.

Copyright

Other than for strictly personal use, it is not permitted to download, forward or distribute the text or part of it, without the consent of the author(s) and/or copyright holder(s), unless the work is under an open content license such as Creative Commons.

Takedown policy

Please contact us and provide details if you believe this document breaches copyrights. We will remove access to the work immediately and investigate your claim.

Design of a New Ship Propulsion System Fundamentals course

Peter de Vos¹

ABSTRACT

In this paper I describe the design of a new course about ship resistance and ship propulsion system fundamentals. The occasion for designing a new course on this topic was the re-design of the Maritime Technology Bachelor of Science programme at Delft University of Technology in the Netherlands. Especially the alteration to another teaching methodology meant a new design was required for the course and led to the introduction of a Mean Value First Principle dynamic model of a ship propulsion system for voyage simulation. The integration of such a model in an educational environment is challenging. The results of the design effort are discussed in this paper by analysis of the models students developed during the first time the course ran and the feedback that was obtained from them.

KEY WORDS

Ship resistance; Ship propulsion system; Education; Mean Value First Principle model

INTRODUCTION

In an effort to help students obtain a clear overview of the educational programme in which they are enrolled, all Bachelor of Science (BSc) educational programmes at Delft University of Technology (DUT) in the Netherlands were re-designed over the past few years to include larger courses. The idea is that students become more effective in finishing their courses successfully when they have a better overview of the overall programme as a consequence of fewer courses. For example, in the previous Maritime Technology Bachelor of Science (MT-BSc) programme courses were typically two, three or four ECTS large. ECTS (European Credit Transfer System) is the European system to measure the weight of study programme components; in the Netherlands one ECTS equals approximately 28 hours of study. Each year contains sixty ECTS and at DUT these are divided over four periods per year. So each period contained approximately $60/4/3 = 5$ courses in the previous programme. The larger courses in the new MT-BSc programme are six ECTS large, resulting in 2.5 courses per period (some courses run for two periods; i.e. one half (3 ECTS) in one period and one in the next).

Within the framework of this university-wide re-design effort of BSc educational programmes, two courses of the previous MT-BSc programme about ship propulsion system fundamentals were combined into a new course. One of these focussed on ship resistance and propulsors, while the other focussed on driving machinery like diesel engines and gas turbines. The content of the new course is roughly the same as the previous ones but employs a different teaching methodology: it is more project-oriented than before. This means that the students get an assignment (as a group of four in this case) at the start of the course and the assessment is based on their performance in executing the assignment during the course period. This is different from “classical” courses, which are individual and are assessed using an exam at the end of the course. Lectures discussing the theory are still given in the new, project-oriented course but they now provide immediate support for the project assignment instead of providing support for preparations for the final exam.

The reason for the course being project-oriented is found in the set-up of the new curriculum, which is a mixture of classical courses and project-oriented courses. Each period (at least in the first MT-BSc year) consists of a three ECTS classical lecture on mathematics (one half of a six ECTS course on mathematics), a six ECTS classical lecture on fundamental engineering theory and a six ECTS project-oriented course that is related to the engineering theory course. The project-oriented courses are more applied than the other courses in the same period and deal with concrete topics, e.g. a ship propulsion system. Note that this reasoning can also be reversed; the place of the new course in the curriculum is determined by the fact that ship propulsion system fundamentals lend themselves well to be taught in a project-oriented manner. Either way, the fact that the course is project-oriented required new teaching methods and a new way of assessment. This paved the way for the introduction of a new element into the course: Mean Value First Principle (MVFP) dynamic models of ship propulsion systems that are able to simulate ship voyages in the time domain.

¹ Delft University of Technology (DUT), The Netherlands

The objective of this paper is to describe the design of the newly formed ship propulsion system fundamentals course with a focus on the integration of the MVFP model in an educational environment. It will be shown how the model enables students to stand at the helm of a ship (digitally at least) from the start of the course onwards and how it motivates them during the course to master the fundamentals and working principles of ship resistance and ship propulsion systems (including their most important components, i.e. propulsor and driving machine).

First the requirements that were established for the new course will be investigated in the first section of this paper. This is followed by a section that describes the organisation of the new course with inclusion of the MVFP model of a basic ship propulsion system. Subsequently the results of the course, and therefore the results of the design effort will be discussed in three sections. The first compares the sub-models for ship resistance, propeller and diesel engine at the beginning and end of the course including the output of these sub-models. The second compares results of voyage simulations with the start and final model, after which the third discusses the feedback that was obtained from the 96 students that were enrolled in the course when it ran for the first time. The last section of the paper contains a conclusion on the successfulness of the design effort and introduces possible improvements and expansion of the new course.

REQUIREMENTS = LEARNING GOALS

Most design processes start with setting up requirements for the system that is to be designed. This applies to ships for example, but to courses as well. So what are the requirements to the new ship propulsion system fundamentals course?

We start here with a general perspective on requirements to higher education courses. At DUT an introduction course on teaching at universities is compulsory for all employees involved with teaching. One of the most important lessons of this course is that learning goals, teaching methods and assessment should be aligned in education. This is a first, over-arching requirement to higher education courses; in importance probably similar to the obvious requirement in ship design that a ship should float upright. The requirement of alignment of learning goals, teaching methods and assessment is depicted in “the teaching triangle” that is reproduced in **Figure 1**. As discussed in the introduction the teaching methodology and the assessment for the new course is different from the previous courses. According to the requirement of alignment this also meant the learning goals had to be re-evaluated. The design of the new course on ship propulsion system fundamentals was therefore achieved by a thorough approach that included re-evaluation of the learning goals, application of a new teaching methodology leading to the integration of MVFP models and new assessment methods.

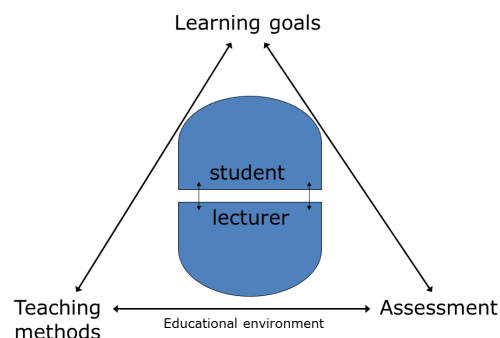

Figure 1: Teaching triangle. Source: Brummelink, 2009.

It is obvious to start the design of a new course with establishing the learning goals, because the learning goals are in fact the requirements the lecturer wants the students to meet at the end of the course. According to the teaching triangle this also means the learning goals pose requirements on both the teaching methods and the assessment: the assessment should test whether students have obtained all learning goals and the teaching methods should support the students in obtaining them. Thus a list of learning goals can be used as a specification of requirements to the course. Therefore the first action that was taken in designing the new course was defining a list of learning goals.

The learning goals of the previous courses could be used as a starting point, but since the new course employs a different teaching methodology a critical re-evaluation of these was necessary. In practice this meant that two new learning goals were defined as a result of the inclusion of the MVFP model of a basic ship propulsion system in the new course, while the others were derived from the learning goals of the previous courses. The list of learning goals for the new ship propulsion system fundamentals course is given in **Table 1**; the first two represent the newly defined learning goals. The latter four, with respect to reporting and oral presentations, also originate from one of the previous courses. They might seem somewhat strange considering the technical character of the other learning goals, but they are part of a general skills package that is accommodated for throughout the MT-BSc programme within different courses. The subject matter needed to obtain these learning goals is taught and assessed by different teachers, with a background in the Arts. The course benefits from the integration of these general skills by the significant improvement in readability of the written reports. Next to that the technical subject matter of the course is discussed abundantly in the many oral presentations that are given by the students themselves on the course subject.

Table 1: Learning goals of the new Ship Resistance and Propulsion Systems course

After successful completion of this course students are able to:
w.r.t. Ship Propulsion Systems:
- Describing the most important components of ship propulsion systems and their function.
- Performing meaningful voyage simulations of a ship in the time-domain using a computer model that describes ship resistance and the propulsion system.
w.r.t. Ship Resistance:
- Describe the origin of ship resistance from general fluid mechanics and explain the implications for hull design.
- Describe and apply the definition of ship resistance and its components.
- Derive similarity laws for (hydro mechanical) model experiments using dimensional analysis and apply these on towing tank tests.
w.r.t. Propulsion:
- Describe the origin of lift from general fluid mechanics and explain the implications for ship propellers.
- Describe geometric variables of propellers in as far as necessary for using open water diagrams and matching with engine envelope.
- Describe design variables of a propeller in as far as necessary for matching with engine envelope.
- Explain the meaning of lines in the open water diagram.
- Determine the operational point of a propeller in the open water diagram using a computer model.
w.r.t. Driving Machinery:
- Describe geometric variables of internal combustion engines.
- Describe performance parameters of marine diesel engines..
- Explain the meaning of lines in the engine envelope.
- Determine the operational point of a diesel engine in the engine envelope using a computer model.
w.r.t. Reporting:
- Structure a written report.
- Apply general reporting skills; referring correctly, figures, tables and text are attuned to each other, etc.
w.r.t. Oral Presentations:
- Structure an oral presentation.
- Use audio-visual aids for a presentation.

ORGANISATION OF THE NEW COURSE WITH INCLUSION OF MVFP MODEL

Now that the learning goals for the new course have been defined the focus of this paper turns to the teaching methods that aim to support the students in obtaining them. As introduced the teaching methodology is project-oriented, meaning that the students have to solve a large assignment as a group (each group consisting of four students). The assignment all student groups get is to increase the fidelity of a Mean Value First Principle (MVFP) model of a basic ship propulsion system by including more first principles. They have eight weeks to do so; in these eight weeks they have to hand in reports regularly to show their progress. In fact there are four sub-assignments; each requiring the students to hand in a part of their final report. In this way the final report develops gradually during the period so finishing it in the eighth week should not be too much work (freeing them up to focus on the final exams of the classical courses that run in the same period).

At the start of the course the students receive a “start-model” of a basic ship propulsion system and a project description that describes the start-model plus the different assignments. **Figure 2** shows a block diagram of the start-model, which is implemented in Matlab[®] and Simulink[®]. The right part of this figure shows the forces that act on a ship that moves unidirectional in calm water: ship resistance as a consequence of primarily skin friction and wave-making and a thrust force delivered by the propulsor(s). If the sum of these forces is non-zero acceleration or deceleration occurs and ship speed v_s changes. Note that the fact that the model includes ship translational dynamics like this provides a strong link with the fundamental engineering theory course that is taught in the same period as the ship propulsion system fundamentals course: Dynamics. This strong link is repeated on the left-hand side of **Figure 2**, since the students also learn about Newton’s laws for rotating bodies in Dynamics, which is included in the start-model through the shaft rotational dynamics. There, the torque as required by the propulsor(s) and as delivered by the driving machine(s) are compared; if their sum is non-zero angular

acceleration or deceleration of the shaft system occurs and the rotational speed of the propeller and drive shafts change (n_p resp. n_e).

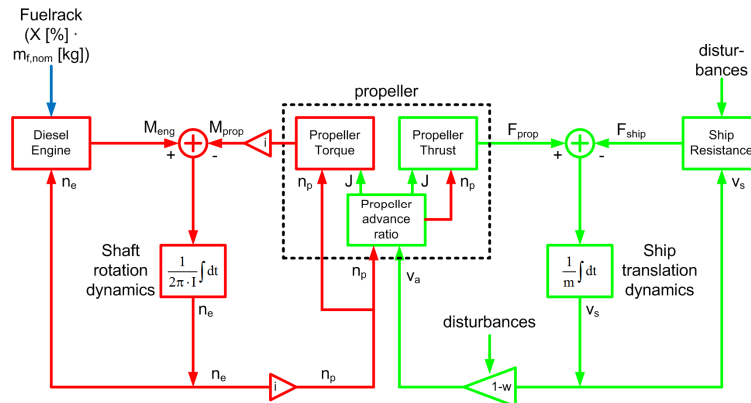

Figure 2: Ship propulsion system model showing main components and relations. Source: de Vos 2014

In the start-model relatively simple models exist for the most frequently applied propulsor and driving machine: a screw-type propeller and a marine diesel engine. These will be described shortly together with the simple ship resistance model. Although the model conceptually can contain multiple propellers and engines, the start-model contains one of each. This results in a simple overall ship propulsion system model for a very common ship propulsion system containing one four-stroke, medium speed diesel engine driving one screw-type propeller to propel one ship. The fact that a medium speed diesel engine is implemented necessitated the inclusion of a gearbox in the model as well, which is done by simply including the gearbox ratio i in **Figure 2** (this in fact assumes a perfect gearbox, i.e. without losses). A reason to also include a gearbox in the model could be that it can be considered a major component of a ship propulsion system as well and thus should be included, but in fact the reason in this course comes from the ship resistance, or rather the ship type that has been chosen for the case-study: a typical beamtrawler fishing vessel. This kind of vessel is normally driven by a four-stroke, medium speed diesel engine and thus includes a gearbox. Since principally the choice has been made for the course and model to represent reality as much as possible, it was chosen to include a medium speed diesel engine and thus a gearbox in the start-model. Choosing a beamtrawler as the case-study of the course originates from the fact that a towing tank model of such a vessel is available at DUT and in fact towing tests with this model are performed during the course to measure ship resistance at model scale. None of the above design variables (ship type, propulsor type, driving machine type, gearbox ratio, etc.) change during the course; at least not in the current set-up. Clearly this is an opportunity to develop the course even further in the future.

As said the ultimate goal of the students during the course is to increase the fidelity of the ship propulsion system model that contains relatively simple (but effective) sub-models for ship resistance, propeller and diesel engine in the start version. This is achieved by modelling the resistance, propeller and diesel engine more correctly, i.e. using more first principles. The students do this by performing four assignments. The first assignment aims for the students to get to know the start-model and do some experiments with it, thereby also obtaining basic Matlab and Simulink skills which will be needed later on in the course. The second assignment is to increase the level-of-detail of the ship resistance block. The third is to increase the level-of-detail of the propeller block and the fourth is increasing the level-of-detail of the diesel engine block. Before these assignments can be described in more detail a necessary description of the contents and assumptions of the start-model is given below.

Start-model description

The contents of the blocks in the start-model will now be described on basis of **Figure 3**, which shows the top-layer of the start-model; i.e. the actual implementation of the block diagram of **Figure 2** in Simulink.

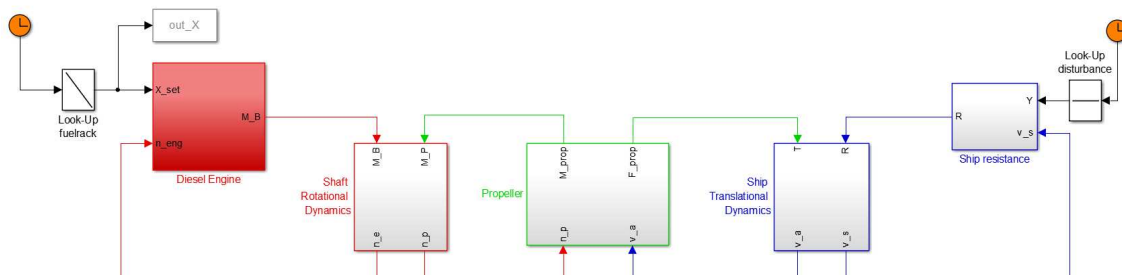

Figure 3: Top-layer of ship propulsion system start-model in Simulink.

The Ship resistance block in **Figure 3** contains a simple square resistance curve:

$$R = Y \cdot c_1 \cdot v_s^2 \quad [1]$$

Where R is ship resistance in N, c_1 is a constant in kg/m and v_s is ship speed in m/s. Y is a factor that represents disturbances on the square resistance curve due to e.g. sea state or hull fouling; its value is normally 1. The output of the ship resistance block is hull resistance at a certain speed; thrust deduction factor t is also taken into account (and assumed constant), but this is done in the next block: Ship Translational Dynamics. Here the hull resistance is adjusted for the effect of increased resistance due to propelling the hull with an aft-mounted screw-type propeller. This results in the required thrust force by the ship-propeller combination (F_{ship} in **Figure 2**) at a certain ship speed. This required thrust force is subtracted from the propeller thrust force, which comes into the Ship Translational Dynamics block from the Propeller block. The second law of Newton for linear motion as implemented in the Ship Translational Dynamics block then dictates any changes in ship speed, which is subsequently immediately adjusted for the wake factor w . Therefore this block has two outputs: ship speed v_s as required by the Ship resistance block and advance speed of the propeller v_a as required by the Propeller block.

The Propeller block contains a linear approximation of lines in the open water diagram:

$$\begin{aligned} K_{T,prop} &= K_{T,A} \cdot J + K_{T,B} \\ K_{Q,prop} &= K_{Q,A} \cdot J + K_{Q,B} \end{aligned} \quad [2]$$

These approximations are used to find the operational point of the propeller at a certain advance ratio J that depends on ship speed v_s and rotational speed n_p (the inputs of the Propeller block). This in turn results in the delivered thrust force and required torque by the propeller (the outputs of the Propeller block):

$$\begin{aligned} J &= \frac{v_a}{n_p \cdot D} \\ F_{prop} = T &= K_{T,prop} \cdot \rho \cdot n_p^2 \cdot D^4 \\ M_{prop} = \frac{Q}{\eta_R} &= \frac{K_{Q,prop} \cdot \rho \cdot n_p^2 \cdot D^5}{\eta_R} \end{aligned} \quad [3]$$

The Propeller block is the only block in the start-model that contains “sub-systems” within; thereby increasing the number of layers in the model from two to three, see **Figure 4**. The blocks Advance Ratio, Propeller Thrust and Propeller Torque contain the implementations of equations [2] and [3]. The number of layers of a model is an indication of the level-of-detail and indeed the propeller is the most detailed sub-model in the start-model of the ship propulsion system. Methods have been sought to simplify the propeller model even further, but it was concluded it could not be avoided to include an approximation of the open water propeller diagram in the start-model and this in fact is the simplest model of a propeller (for our purposes) possible. This regrettably also means that the third assignment, increasing the level-of-detail of the propeller model, is not very challenging (the linear approximations are enhanced to square approximations) as it is equally difficult to find slightly more complex models than square approximations of the lines in open water diagrams. Lifting line theory probably provides the next step on a gliding level-of-detail scale in propeller modelling (from simple mathematical models on one end to full-fledged CFD models at the other end), but this is quite a step and requires a lot more details of e.g. propeller blade geometry. This was deemed too difficult for the current course in the first year of the MT-BSc programme and lifting line theory is introduced to the students in a follow-up course that is scheduled in the second MT-BSc year.

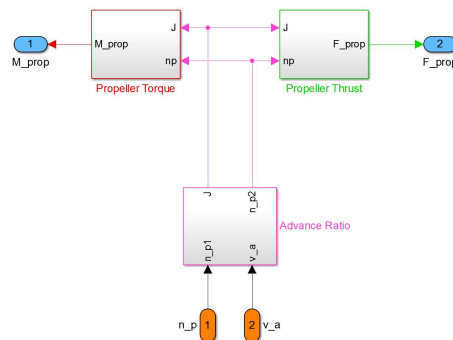

Figure 4: Contents of Propeller block in start-model in Simulink.

The Shaft Rotational Dynamics block requires two inputs: the required torque of the propeller and the delivered torque of the engine. The engine torque comes from the Diesel Engine block and is transformed in the Shaft Rotational Dynamics block to the torque delivered at the propeller flange using the gearbox ratio i_{GB} and the transmission efficiency η_{TRM} (so in fact, in the actual start model gearbox and shaft losses are taken into account). The second law of Newton for angular motion dictates

any changes in propeller rotational speed, which in combination with the gearbox ratio i_{GB} also results in the engine rotational speed n_e . These represent the two outputs of the Shaft Rotational Dynamics block: the propeller rotational speed n_p as required by the Propeller block and the engine rotational speed n_e as required by the Diesel Engine block.

The engine sub-model in the start-model assumes constant engine efficiency, which provides a way to directly calculate engine torque from fuel mass injected to the cylinders:

$$M_B = \frac{1}{2\pi} \cdot \frac{i}{k} \cdot W_e = \frac{1}{2\pi} \cdot \frac{i}{k} \cdot (m_f \cdot LHV \cdot \eta_e) \quad [4]$$

$$m_f = X_{set} \cdot m_{f,nom}$$

Where M_B is engine torque in Nm, $i = n_{cyl}$ is the number of cylinders of the engine, k is the number of revolutions per power stroke ($k = 1$ for two-stroke and $k = 2$ for four-stroke engines), W_e is the effective work per cylinder per cycle in J, m_f is the amount of fuel injected per cylinder per cycle in kg ($m_{f,nom}$ is nominal fuel injection), LHV is the Lower Heating Value of the fuel used in J/kg, η_e is the engine efficiency (assumed constant) and X_{set} is the setting of the fuel rack (between 0 and 1, with 0 representing no fuel injection and 1 representing engine nominal point, i.e. maximum engine torque).

Note that the engine rotational speed is not required to calculate engine torque (the output of the Diesel Engine block), which is true for ideal engines that act as constant-torque machines as described in (Klein Woud e.a. 2003). There are two reasons for having engine rotational speed as an input to the Diesel Engine block nonetheless; one being that engine speed is required for calculating engine power (together with engine torque) and this is done in the Diesel Engine block as well and two being that the engine speed will be required by a more advanced model in which engine efficiency is not constant and losses depend on engine rotational speed. The latter is of course the objective of assignment four (increasing the level-of-detail of the diesel engine sub-model) and thus it is a matter of good preparation to have the engine speed as an input to the Diesel Engine block in the start-model already. This also means the top-layer of the overall ship propulsion system model will not have to change while the students are carrying out the assignments during the course, which serves two purposes:

- Students are forced to understand the overall system from the start of the course (providing them a good top-down overview).
- Students have something to hold on to in case they might feel lost in carrying out an assignment.

Assignment 1

The first assignment introduces the students to the working principles of ship propulsion systems, the function of different components and the start-model. The students are tasked with performing a number of experiments (voyage simulations) with the start-model. These are:

- Decrease fuel rack setting X_{set} with steps of 25% after a certain time interval.
- Suddenly change disturbance factor Y with a factor of 1.5 at time t without changing fuel rack setting X_{set} .
- Increase fuel rack setting X_{set} from 100% to 2000%.
- Make the fuel rack setting follow a sinusoidal wave form.
- A relevant experiment of own invention.

The first experiment simulates a helmsman changing the fuel rack at time intervals to decrease ship speed. This experiment is designed for the students to relate the results of the abstract ship propulsion system model to real life experience. Since most of the students have sailed a small motor yacht or similar they know from personal experience that ship speed can be controlled by adjusting “some lever”. Experiment one makes use of such experience and triggers the student to find out what actually happens when they change the lever position, i.e. the fuel rack. The results of this small voyage simulation with the start-model appear within seconds (as the model is very fast) and students can immediately relate their personal experience to the results.

The second experiment simulates a sudden increase in ship resistance due to e.g. increased sea state. Again the experiment is designed to relate the model results to real life experience. Students should be able to comprehend that if the fuel rack setting remains constant an increased resistance leads to decreased ship speed. This is of course also the result of experiment 2 that is again shown within a couple of seconds.

The third experiment is actually the first occasion to make students realize that the fidelity of the start-model needs to be increased. In the start model it is possible to increase fuel rack limitlessly, which also means there is no maximum ship speed. Since a real ship does have a maximum ship speed all student should realize that the results of the start model cannot be trusted blindly. Experiment 3 makes students contemplate the origin of maximum ship speed: limited engine power.

The fourth experiment is designed to help students cross a potential barrier of starting to work with Simulink. After the first three experiments students should start to grasp the working principles of the start model in Simulink; the next step is making changes to that model (of a ship propulsion system). Therefore experiment 4 only trains programming skills in Simulink.

Experiment 5 finally is an opportunity for (well-motivated) students to show their creativity and comprehension of the start-model.

The deliverable of the first assignment is a written report containing a description of the start-model, the results of the five experiments and a discussion on these results. This report needs to be handed in with the lecturer two weeks after the course commenced. If a student-group fails to learn the basics of ship propulsion systems in the first two weeks, the remainder of the

course will be difficult for them to understand. This is why the report the students hand in at the end of the second week is discussed with each group separately. This provides the lecturer with an opportunity to press students that are already falling behind to increase their effort. Well-performing students are told they are on the right track, but it is wise to show them possible improvements as well to avoid that these students lose their motivation.

Assignment 2, 3 and 4

Assignment 2, 3 and 4 are the core assignments in which the different sub-models for Ship Resistance, Propeller and Diesel Engine are improved to increase the fidelity of the overall ship propulsion system model.

Starting with the resistance again the model is improved by the students in assignment 2 from the basic square resistance curve in the start-model (expression [1]) to using towing tank model resistance test measurement results in Simulink and extrapolating these to the actual scale of the ship according to the recommended ITTC-procedure (ITTC, 1978). The measurement results that are used are obtained by the students themselves by performing a resistance test with a physical model of a beamtrawler; typically this is the first time for students to experience towing tank tests. The extrapolation to actual scale needs to be implemented in Simulink and described in another report that discusses how assignment 2 was solved by the students. Although this report (nor the reports of assignment 3 and 4) is *not* discussed with the students as was done for the first report, the lecturer can keep track of the progress students are making and take action if so required. Furthermore handing in reports regularly serves of course the purpose of students maintaining their focus. The results of the final model for ship resistance as developed by the students in assignment 2 will be presented in the next section and compared with the results of the start-model.

Assignment 3 is less of a challenge than assignment 1 and 2 (or 4 for that matter), as already described in the previous section. The linear approximation of lines in the open water diagram are enhanced to second order polynomial approximations:

$$\begin{aligned} K_{T,prop} &= K_{T,A} \cdot J^2 + K_{T,B} \cdot J + K_{T,C} \\ K_{Q,prop} &= K_{Q,A} \cdot J^2 + K_{Q,B} \cdot J + K_{Q,C} \end{aligned} \quad [5]$$

The polynomial coefficients in the above equation should be determined by the students in assignment 3 on basis of measurement results obtained during open water propeller tests, similar to the resistance test that was performed for the ship resistance. After doing so, the implementation of expression [5] in Simulink should be quite straight forward. Again a report needs to be handed in describing how the students solved assignment 3.

Assignment 4 deals with the last main component of a ship propulsion system; the diesel engine. As already discussed the main assumption for the diesel engine model was a constant efficiency. Clearly this needs to be improved if one wants to be able to accurately predict fuel consumption for instance. Ideally a test with a diesel engine would be performed for this assignment to uphold the symmetry between assignments 2, 3 and 4. However, this is not possible for two reasons. One is that the students have not done a course on thermodynamics yet and it is hard, or at least strange, to do measurements on a diesel engine without any knowledge of the cylinder process, even more so if the goal of the measurements is to find the different losses that occur (i.e. combustion, heat and frictional losses). More importantly it is even more difficult, if not impossible, to scale up measurement results of diesel engine losses than it already is to scale up resistance test and open water propeller test measurement results. As far as the author knows no procedures exist for this, which is no surprise as diesel engine performance is never measured at a small scale. Diesel engine performance is always measured at full scale because many processes that occur in diesel engines cannot be scaled easily, like heat release, heat losses and lubrication, let alone independently. Thus, to do measurements for assignment 4 a full scale, representative (beamtrawler) diesel engine is required, which is simply unaffordable. This is the second reason why the symmetry between assignments 2, 3 and 4 is lost.

So another solution had to be found in order to enable the students to increase the level-of-detail of the diesel engine model and improve on the assumption of constant engine efficiency. The method used should also introduce the students to relevant physics for internal combustion engines, as the other assignments aimed to increase the students insight into relevant physics as well (and this is main objective of the entire study programme). In order to do this the different losses that occur in a diesel engine are introduced qualitatively to the students during lectures, after which these losses are quantified in a number of different, simple ways in the description of assignment 4.

To understand the assumptions as given in assignment 4 we first have to note that engine efficiency can be divided into partial efficiencies that describe the relative contribution of different losses to overall engine efficiency. In the course book (Klein Woud e.a., 2003) expression [6] is used which divides engine efficiency into combustion efficiency, heat input efficiency, thermodynamic efficiency and mechanical efficiency.

$$\eta_e = \eta_{comb} \cdot \eta_q \cdot \eta_{td} \cdot \eta_m = \frac{Q_{comb}}{m_f \cdot LHV} \cdot \frac{Q_{heat\ input}}{Q_{comb}} \cdot \frac{W_i}{Q_{heat\ input}} \cdot \frac{W_e}{W_i} \quad [6]$$

The first one, combustion efficiency, represents losses due to incomplete combustion and is defined as the ratio of heat released by fuel that is combusted over heat that could have been released if all injected fuel would have been combusted. Since combustion efficiency is normally one, i.e. all fuel is combusted, the text of assignment 4 states that combustion losses are zero. The students have to realise themselves that this means combustion efficiency is one. The second one, heat input

efficiency, represents the relative contribution to overall engine efficiency of heat that is lost through the cylinder wall (or via lubrication oil) to cooling water. It is normally in the range of 0.8 – 0.9 near the nominal operational point of engines, but quickly drops at lower load. It depends mainly on in-cylinder temperatures, which in turn depends on the amount of fuel that is combusted. This is reflected in the linear function that is defined in expression [7], since fuel rack setting X determines fuel mass injected into the cylinder. The expression gives heat lost to cooling water etc. that is related to heat input by $Q_{heat\ input} = Q_{comb} - Q_{heat\ loss}$. The third one, thermodynamic efficiency, is completely determined by the cylinder process, which the students do not know yet (in fact the course Thermodynamics in which internal combustion engine cycles are introduced follows in the next period). Therefore the thermodynamic efficiency, although it represents the largest loss in diesel engines, is assumed constant in assignment 4 which means the cylinder process is still by-passed. This assumption is quite similar to the assumption of overall engine efficiency being constant in the start-model, but it is more realistic as detailed performance models of marine diesel engines show that changes in overall engine efficiency are dictated by heat input and mechanical efficiency (and the mean value by the relatively constant thermodynamic efficiency). The last one, mechanical efficiency, represents losses due to friction in bearings etc. and pumping losses due to attached pumps for transport of fuel, lubrication oil, cooling water, etc. It is normally in the range of 0.85 – 0.95 near the nominal operational point of engines, but quickly drops at lower load, like the heat input efficiency. The mechanical losses depend amongst other things on engine speed, which is reflected in the linear function in expression [8]. Effective work W_e that is delivered by one cylinder depends on the mechanical losses by $W_e = W_i - W_{mech.\ loss}$.

$$Q_{heat\ loss} = 1908.8 + 7635.2 \cdot \left(\frac{X_{act}}{X_{nom}} \right) \tag{7}$$

$$W_{mech.\ loss} = 711.1 + 1659.3 \cdot \left(\frac{n_{e,act}}{n_{e,nom}} \right) \tag{8}$$

The polynomial coefficients used in the above expressions were derived using a more advanced first principle diesel engine model which contains proper models for the losses and thus gives feasible results for engine efficiency. One could argue to use this model in the course, but it would be far too complicated for the students at this point in their career to apply. Now that all four partial efficiencies in expression [6] are known or can be calculated the students are able to calculate overall engine efficiency by implementation of the theory and expressions above in the diesel engine model. Since the heat input efficiency and mechanical efficiency change depending on the operational point of the engine the overall engine efficiency will change with engine operational point as well. Again the students are tasked with handing in a report that describes how they solved assignment 4.

After this last assignment the course is almost finished and the students only need to finalize their report which has been gradually built up through the reports of the four assignments. The only addition to the final report that still needs to be made is a comparison between the start-model and the final model with increased fidelity because of the higher level-of-detail of ship resistance, propeller and diesel engine model respectively. This comparison will be discussed in the next section.

COMPARISON OF START-MODEL AND FINAL MODEL

As stated before there are no changes in the top-layer of the model during the course, i.e. **Figure 3** remains the same. Assignment 2, 3 and 4 do cause changes in the blocks Ship resistance, Propeller and Diesel Engine resp. The changes made in these sub-models during the course represent student progress. The changes in these sub-models will now be presented by comparing the contents of the blocks in start-model and final model. Output of these blocks in start and final model will also be compared.

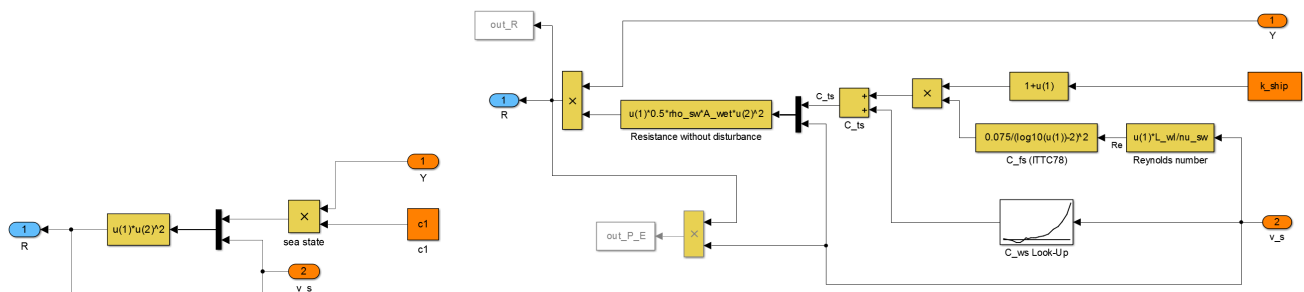

Figure 5: Contents of Ship resistance block in start-model (left) and final model (right).

Figure 5 shows how the contents of the Ship resistance block have changed as a consequence of assignment 2. The figure on the left hand side shows the implementation of expression [1] in the start-model in Simulink, on the right hand side we see one of the many ways in which the recommended ITTC procedure can be implemented in Simulink. This is probably the neatest way; many other, less neat models have been received as well from other student groups. Results should anyway be

similar of course. **Figure 6** shows what the consequence is for the ship resistance curve; after scaling up the towing tank results it becomes clear that the assumption of a square resistance curve was very crude. Professionals know this of course as they know beamtrawlers are fast-sailing vessels in free-sailing condition; Froude numbers up to 0.4 or so. With such high Froude numbers wave-making resistance plays of course a significant role in the total ship resistance, which is why the square resistance curve is no reasonable assumption. For ships with far lower Froude numbers the square resistance curve is a more reasonable assumption as viscous resistance dominates total ship resistance; viscous resistance is a function of ship speed squared. One could say that a beamtrawler is equipped with a rather “large” (too large) propulsion system if one considers only the free-sailing condition for this kind of ship. But the large propulsion system is of course there to overcome the significantly increased resistance when in fishing condition (due to the extra resistance of the beam that is towed over the ground and the filled fishing nets). It is these kind of insights that are new to the students and are best discovered by them by “experiencing the theory”, which is what a project-oriented course aims to do.

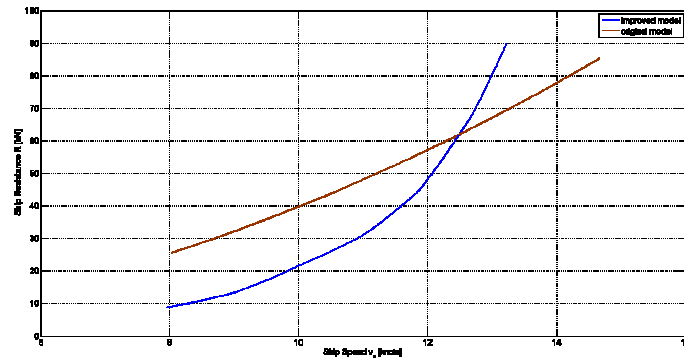

Figure 6: Ship resistance as a function of speed for the start-model (brown line) and for the final model (blue line).

The changes in the propeller model are not that large as can be seen from **Figure 8**; the left figure shows the implementation of expression [2] for the thrust coefficient in the start-model, the right figure the implementation of expression [5] for the thrust coefficient in the final model. The fit on the lines in the open water propeller diagram has improved significantly though by changing from a first to a second order polynomial function, as can be concluded from **Figure 7**; the R^2 -values of both the 1st order (start-model) and 2nd order (final model) polynomial fit are given in the figure as well.

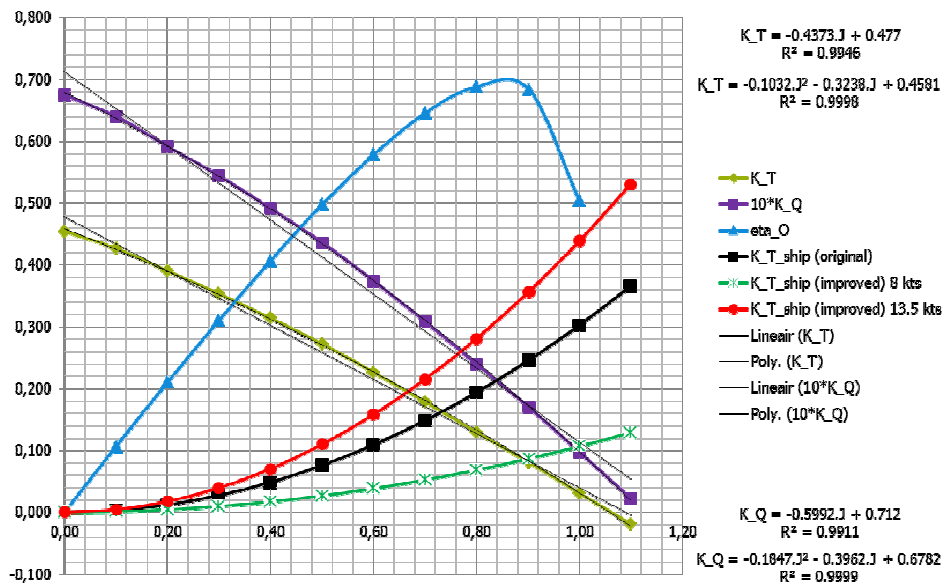

Figure 7: Open water propeller diagram including linear and 2nd order polynomial fit of K_T and K_Q .

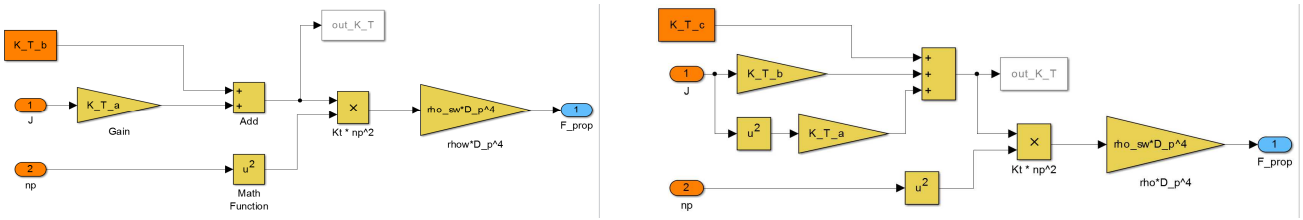

Figure 8: Contents of Propeller Thrust block (inside Propeller block) in start-model (left) and final model (right).

Figure 7 also shows curves for required thrust coefficient of the ship $K_{T,ship}$ for a number of situations. In the start-model the position of this curve did not change with ship speed since a square resistance curve was assumed. In the final model it does change (quite significantly) because of the steepness of the resistance curve at high speeds due to wave-making resistance. Finally the changes inside the Diesel Engine block as a consequence of assignment 4 are shown in Figure 9. The two expressions [7] and [8] can be distinguished as well as the combustion loss (0) and the thermodynamic efficiency (assumed constant). Note that the fact that mechanical losses now depend on the rotational speed of the engine means that this is now indeed a required input of the model, as was already foretold in the description of the start-model. Notice also that a “saturation” block has been added to limit the fuel rack, which in turn means engine power is limited and ship speed is limited as well; so it is no longer possible to sail faster than e.g. a jet-fighter can fly according to the model. This of course increases the fidelity of the model significantly. Furthermore the partial and overall engine efficiencies are calculated (in a separate sub-system to keep the model neat). These are plotted in Figure 10 as a function of load; actually as a function of fuel rack but since the propeller is always coupled to the engine and these are matched fuel rack is a measure for load. It can be clearly seen that now indeed the overall engine efficiency depends on the operational point of the engine and is lower at lower load, which is well-known to anyone knowledgeable about marine diesel engines.

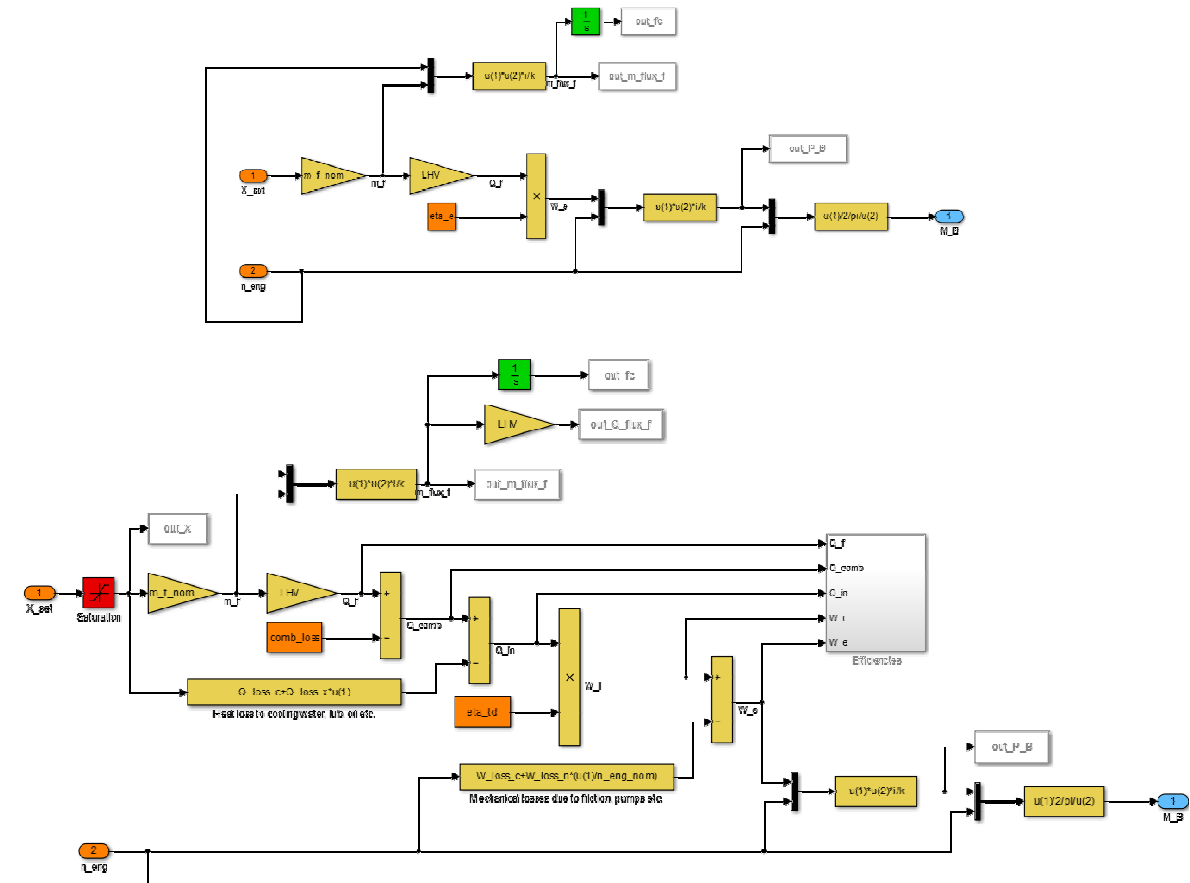

Figure 9: Contents of Diesel Engine block in start-model (top) and final model (bottom).

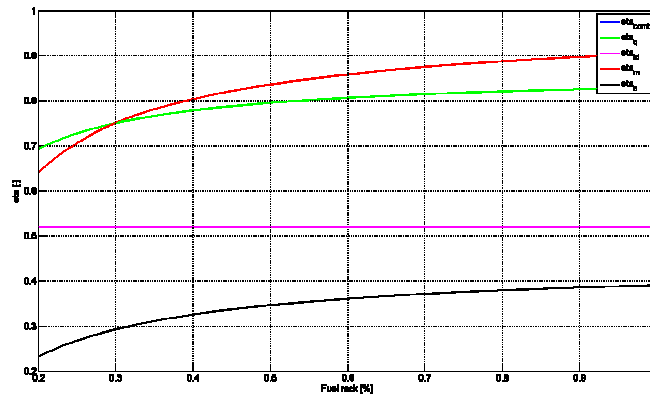

Figure 10: Partial efficiencies and overall engine efficiency as a function of load.

A comparison of the changes in the engine envelope going from start-model to final model has also been made, but this was not done by the students (as it was not required). This is shown in **Figure 11**. Note that the case study object (beam trawler) is, in hind side, not a wise choice for this course, since the matching of propeller and engine would be different in reality than is now suggested. Since the mission of beam trawlers is to fish by towing a beam over the ground and nets through the water, the propulsion system must be matched very lightly if one considers the free-sailing condition, in order to leave margins for the far heavier (almost bollard-pull) fishing condition. Practically this means the gearbox ratio would have been chosen differently during the design as was done for this course. A bonus was promised to the students near the end of the course if they would be able to figure this out. One out 96 students did figure this out for which he got the highest grade in the course.

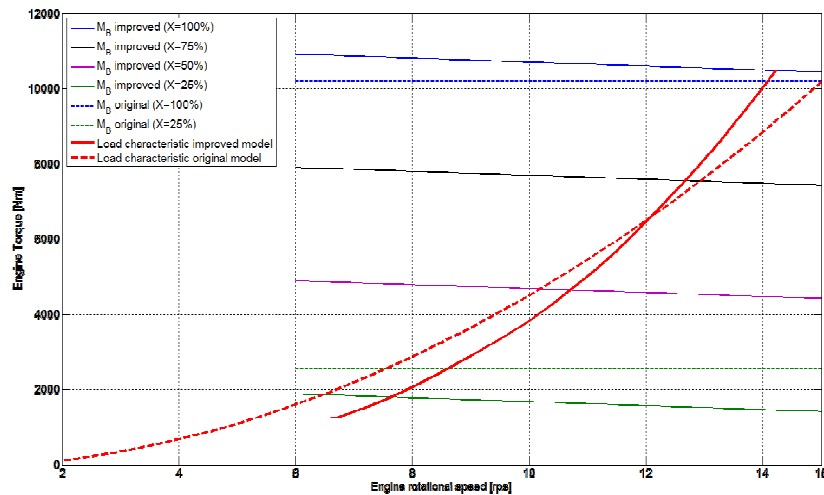

Figure 11: Load lines of ship + propeller in engine envelope for both the start-model and the final model.

RESULTS OF VOYAGE SIMULATIONS

Both start-model and final models can be used to do voyage simulations of the beamtrawler. **Figure 12** shows some of the results; ship speed, distance travelled, amount of fuel consumed and fuel rack setting. In fact, these are the results of the first experiment that is part of the first assignment.

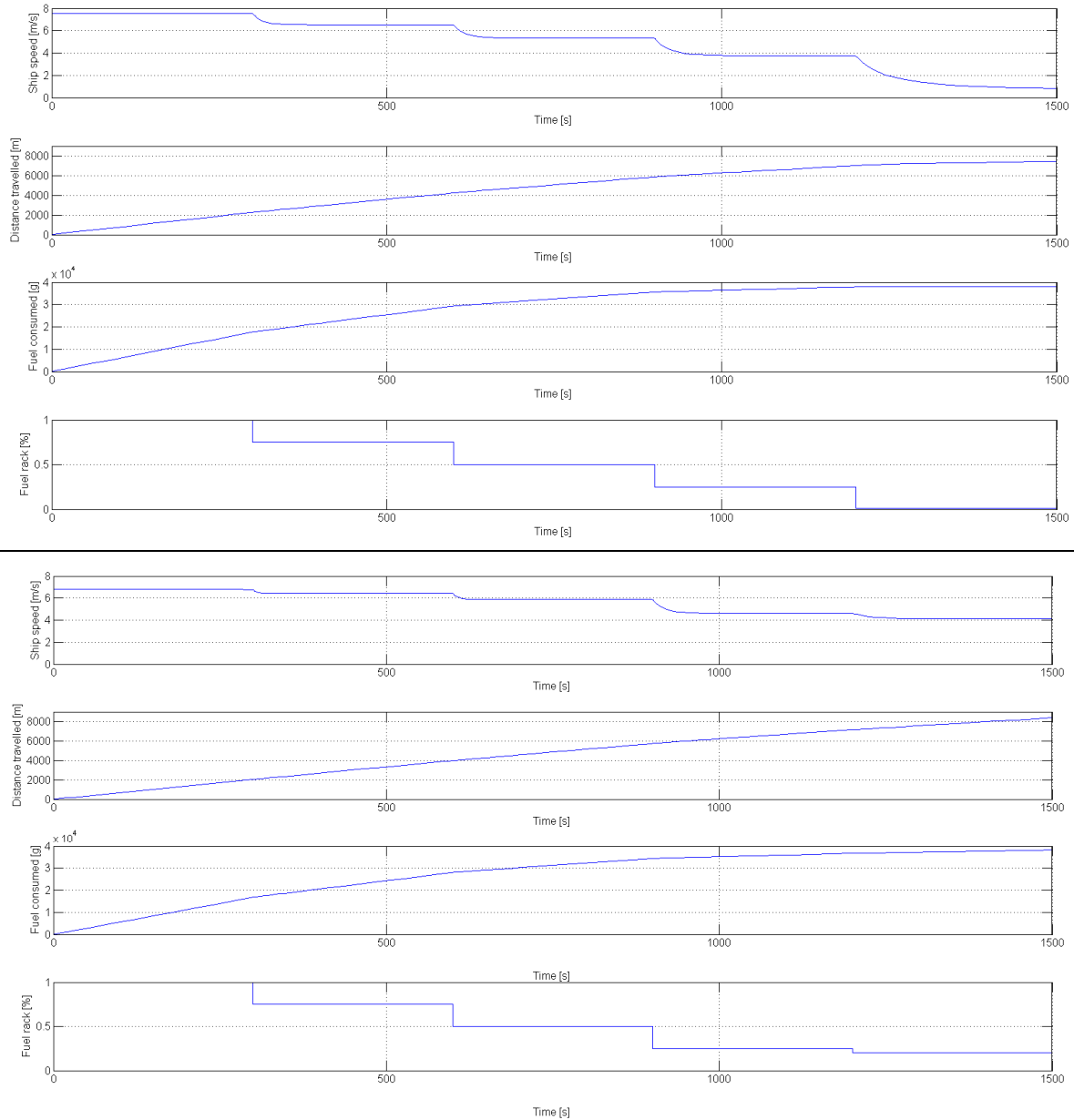

Figure 12: Results of voyage simulations for the start-model (top) and the final model (bottom).

The differences in the results of the voyage simulations between start-model and final model was regrettably somewhat disappointing to some students. Experienced people in modelling know that increasing fidelity of a model does not necessarily lead to large changes in output of the model, but the students are not experienced of course. A low-fidelity model can be very accurate as long as it is applied intelligently; e.g. within the range of values valid for the model (remember experiment 3). The higher-fidelity final model is in this case more accurate than the start-model, but this is mostly a consequence of a more realistic resistance curve. Would the quadratic resistance curve assumption have been more realistic (e.g. if another, lower-speed ship would have been used), then the changes between start- and final model would have been even smaller. Higher-fidelity models are of course developed to reduce the risk of errors and better understand relevant processes, not to increase accuracy. They succeed in this purpose by being more true-to-nature than other models, which also makes them ideally suited to help students gain insight in the laws of physics.

FEEDBACK FROM STUDENTS

How should one measure quality of education? The answer is not so obvious, but an indication is at least found in the response of the students to the course. Clearly as a lecturer you receive a lot of response from the students during the course, but at DUT the students are also asked to fill in an anonymous questionnaire after the course; giving them the opportunity to “speak freely”. The generally positive responses received from the students during the course were confirmed in the response to the questionnaire; the course as a whole was graded by the students with a 7.64 (on a scale of 1 to 10). The results of the complete questionnaire are listed in **Table 2**. Most grades are above 7.5, which is high compared to grades that are normally given by students (for other courses) in the questionnaire. Note that the questionnaire was only filled out by 25% of the students that finished the course (24 out of 96), so no hard conclusions can be drawn from the results.

The lowest scores were obtained for how well the course subject follows up on prior knowledge and on the assessment. The latter is caused by the failure of the individual computer test at the end of the course. To make sure all students study the model, the final model needs to be reproduced during a computer test. The location of this test was at the last moment relocated by the supporting staff of DUT and at the new location Matlab and Simulink did not work. This came across to the students as poor preparation, which it in fact was, only not by the organising lecturers of the course. Hence the low grade on assessment. This problem is easily solved the next time the course runs. The difficulty with following up on prior knowledge is that it has to be assumed the students do not have any prior knowledge on ship propulsion systems; only secondary school physics. The focus on secondary school in the Netherlands is however not on the application of physics, which is why it is quite a step for the students to understand the ship propulsion systems fundamentals course from their prior knowledge.

Table 2: Student response to questionnaire

The course as a whole	7.64
The subject is interesting and challenging	8.08
The relevance of the course for the entire study programme	8.67
Suitability for group work	7.92
Following on prior knowledge	6.79
Course materiel	7.79
Required equipment	7.7
Available information on Blackboard (online teaching environment)	7.63
Organisation of the course	7.5
Lecturers (organised, clear, enthusiastic, feedback, interaction)	8.33
Student-coaches	7.19
Clarity of what is expected	7.46
Assessment	6.45
Amount of time spent on the course with respect to ECTS	7.25

CONCLUSIONS

In this paper, I have described the design of a new course on ship propulsion systems fundamentals with a special focus on the integration of Mean Value First Principle models in an educational environment. Transferring knowledge and insight into the fundamentals and working principles of ship resistance, propellers and diesel engines and the interactions between them is a challenging goal; Mean Value First Principle models support in achieving that goal by forcing students to reflect on the laws of physics that govern ship propulsion system performance. Although many possibilities for improvement and expansion still exist for the course and it has only ran for the first time now it is concluded that, on basis of observations on the progress of students enrolled in the course and their feedback, the design effort was successful.

In the future the course will be expanded to include more ship types. Also minor improvements in the organisation are still possible, which will already be implemented the next time the course runs. On basis of the number of students that have entered the Maritime Technology Bachelor of Science programme it is estimated that this next time will be done with approximately 150 students enrolled in the course.

REFERENCES

Brummelink, M., “Introduction to BTQ course”, PowerPoint presentation (in Dutch) – Delft University of Technology, 2009

ITTC website: www.ittc.sname.org, “Recommended Procedures”, visited January 2014.

Klein Woud, J. and Stapersma, D., “Design of Propulsion and Electric Power Generation Systems”, IMarEST, London, 2003.