

**Assessing residential Smart Grids pilot projects, products and services
Insights from stakeholders, end-users from a design perspective**

Obinna, Uche

DOI

[10.4233/uuid:d2d37a85-5c7c-4e9d-bb37-1283af0d3909](https://doi.org/10.4233/uuid:d2d37a85-5c7c-4e9d-bb37-1283af0d3909)

Publication date

2017

Document Version

Final published version

Citation (APA)

Obinna, U. (2017). *Assessing residential Smart Grids pilot projects, products and services: Insights from stakeholders, end-users from a design perspective*. [Dissertation (TU Delft), Delft University of Technology]. <https://doi.org/10.4233/uuid:d2d37a85-5c7c-4e9d-bb37-1283af0d3909>

Important note

To cite this publication, please use the final published version (if applicable).
Please check the document version above.

Copyright

Other than for strictly personal use, it is not permitted to download, forward or distribute the text or part of it, without the consent of the author(s) and/or copyright holder(s), unless the work is under an open content license such as Creative Commons.

Takedown policy

Please contact us and provide details if you believe this document breaches copyrights.
We will remove access to the work immediately and investigate your claim.

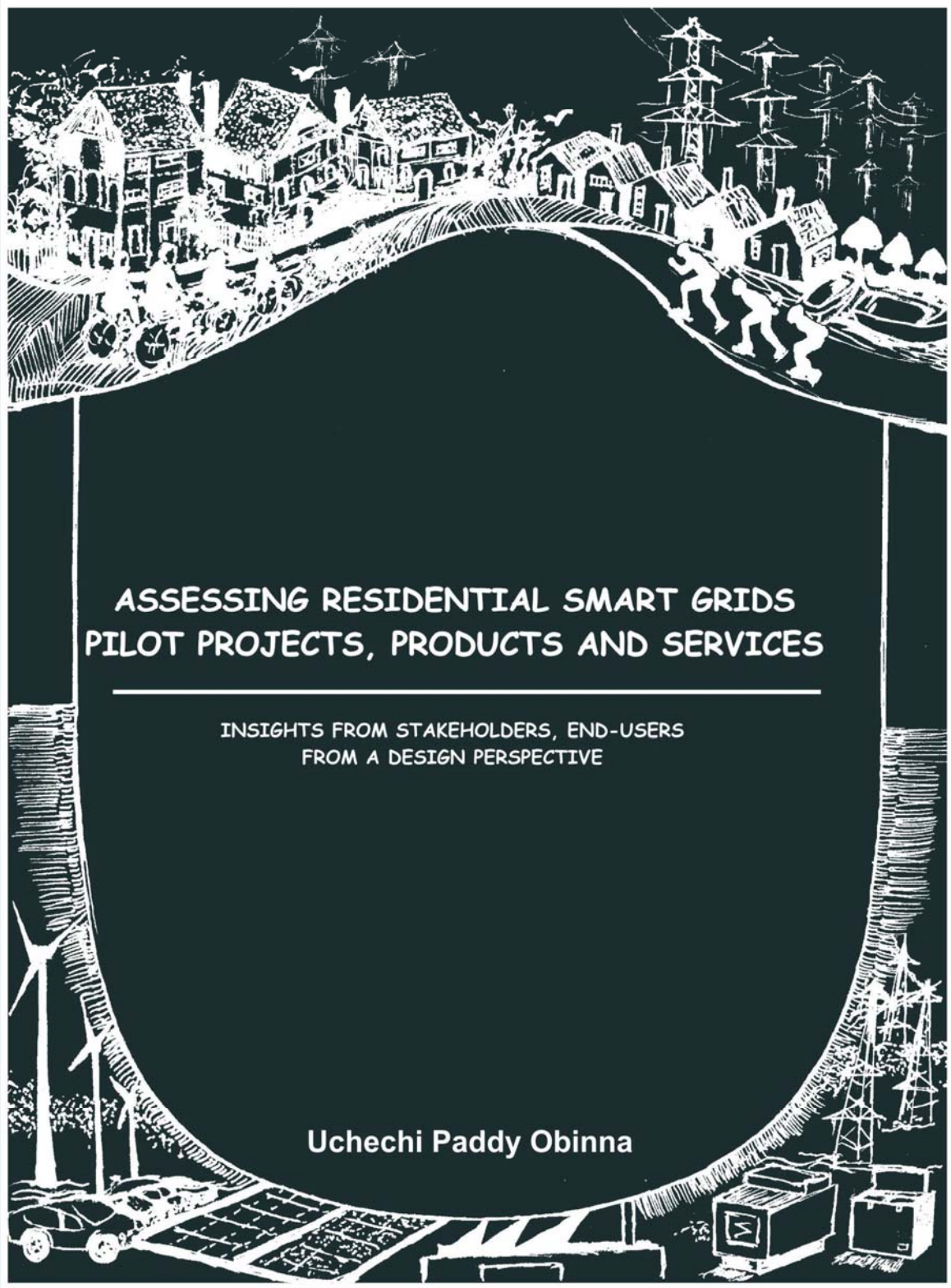

ASSESSING RESIDENTIAL SMART GRIDS PILOT PROJECTS, PRODUCTS AND SERVICES

INSIGHTS FROM STAKEHOLDERS, END-USERS
FROM A DESIGN PERSPECTIVE

Uchechi Paddy Obinna

***Assessing residential Smart Grids pilot projects, products and services:
Insights from stakeholders, end-users from a design perspective***

Uchechi Paddy OBINNA

***Assessing residential Smart Grids pilot projects, products and services:
Insights from stakeholders, end-users from a design perspective***

PROEFSCHRIFT

ter verkrijging van de graad van doctor
aan de Technische Universiteit Delft,
op gezag van de rector magnificus Prof. Ir. K.C.A.M Luyben,
voorzitter van het College voor Promoties
in het openbaar te verdedigen op
maandag 20 november 2017 om 15.00

door

Uchechi Paddy OBINNA

Master of Science in Environmental and Energy Management
geboren te Emekuku, Nigeria

This dissertation has been approved by the promotor:
Prof. dr. A.H.M.E. Reinders (promotor)
Dr. ir. J.P. Joore (copromotor)

Composition of the doctoral committee:

Rector Magnificus, Chairman
Prof. dr. A.H.M.E. Reinders, Delft University of Technology, promotor
Dr. ir. J.P. Joore, NHL University of Applied Sciences, copromotor

Independent members:

Prof. dr. ir. J.C. Brezet, Delft University of Technology
Prof. dr. A.R. Balkenende, Delft University of Technology
Prof. dr. J. Henseler, University of Twente
Prof. dr. ir. R. Wever, Linköping University Sweden

Other member:

Dr. ir. L.S.G.L. Wauben, Rotterdam University of Applied Sciences

Dr. ir. L.S.G.L. Wauben, Rotterdam University of Applied Sciences has, as supervisor,
contributed significantly to the preparation of this dissertation.

This work is part of the research program of University Campus Fryslân (UCF), which is
financed by the Province of Fryslân, the Netherlands.

Assessing residential Smart Grids pilot projects, products and services: Insights from
stakeholders, end-users from a design perspective
Thesis Delft University of Technology, Delft, The Netherlands
Design for Sustainability Program publication nr. 34

Table of Contents

Summary	1
Chapter 1. Introduction to smart grids research	13
1.1 General introduction	13
1.2 Energy transition to decentralized electricity system and smart grids	13
1.3 Issues regarding energy demand and supply	17
1.4 Consequences of the transition to renewable energy use	20
1.5 Smart grids in residential areas	22
1.6 Problem statement	29
1.7 Research objective	30
1.8 Research questions	30
1.9 Outline of the thesis and research methods	30
Chapter 2. Literature study on end-users and stakeholder involvement in residential smart grids	35
2.1 Introduction	36
2.2 Research method	36
2.3 End-user engagement in smart grids	39
2.4 End-users as co-providers in smart grids	42
2.5 Current smart grids products and services for households	44
2.6 End-users interaction with smart grid products and services	47
2.7 Designing for end-user engagement	48
2.8 Conclusions from literature	50
Chapter 3. Stakeholder views on the development and performance of residential smart grid pilot projects in the Netherlands	52
3.1 Introduction	53
3.2 Research background and objective	53
3.3 Research method	54
3.4 Interviews	62
3.5 Data analysis	63
3.6 Results	64
3.7 Discussion and conclusions	74
Chapter 4. Evaluation of energy performance and user experiences in residential smart grid pilot projects	77
4.1 Introduction	78
4.2 Research background	78
4.3 The Smart Grid projects	80

4.4	Research Method	83
4.5	Results	84
4.6	Discussion	102
4.7	Conclusions	104
Chapter 5. Preferred attributes of home energy management products for smart grids: results of a design study and related user survey		107
5.1	Introduction	108
5.2	Research background	108
5.3	Research method	114
5.4	Results	127
5.5	Discussion and conclusion	142
Chapter 6. Conclusion, discussion and recommendations		147
6.1	Conclusions	148
6.2	Discussions and recommendations for the design of future smart grid products and services	157
6.3	Theoretical and practical contributions	159
6.4	Research limitations	160
6.5	Suggestions for further research	161
References		163
Appendices		177
Appendix A. Data tables of electricity meter readings for Pecan Street and PowerMatching City		178
Appendix B. Interview topic guide with smart grid stakeholders		181
Appendix C. Questionnaire survey for evaluation of Home Energy Management Products		183
Appendix D. Numeric results of questionnaire survey analyzed		192
Appendix E. Product concepts for HEMS designed by students in 2013		199
About the author		211
Publications		213
Acknowledgements		214

Summary

The transition of the electricity system to smart grids would require from residential end-users to adapt to a new role of co-provider or active participants in the electricity system. End-users would for instance use energy efficiently, generate renewable energy locally, plan or shift energy consumption to most favourable times (such as when renewable energy is most abundant or during low peak periods), and trade self-produced electricity with other households.

In a residential smart grid, a large part of the electricity supply in households will be generated by various decentralized energy resources like wind turbines, photovoltaic (PV) solar systems and micro-cogeneration systems. In this context, smart grids are supposed to provide the opportunity to make optimal use of renewable energy by matching demand to supply conditions, thereby facilitating the energy transition towards a more sustainable and less fossil fuel dependent society.

In the past years, several smart grid projects have been initiated in Europe and America. In these projects, new energy products and services have been implemented and tested. Also, various new smart energy products or Home Energy Management Products (HEMPs), which are aimed at supporting efficient energy behaviour in households, have been recently introduced in the energy market.

In addition to the development of new energy technologies that balance energy demand and supply, human factors such as interaction of end-users with smart energy products, end-user behaviour towards energy-efficiency, and users' experiences is considered important to stimulate an active end-user participation in smart grids (ETPS, 2011; Top team Energy in Netherlands, 2012; IEA, 2011; Reinders et al., 2012; Geelen et al., 2013). Currently, limited knowledge exists regarding participation and experiences in smart grids, the effects of these products and services on energy performance of households, and expectations of current smart grid products and services.

Considering the importance of a more active participation of end-users in smart grids, this thesis explores and evaluates residential smart grids projects and related energy products and services. This is done by gathering insights from smart grid stakeholders and end-users, and exploring the role of design approaches and end-user expectations of Home Energy Products for households. These insights are aimed at supporting the development of new innovative smart grid products that support end-users in energy management in a smart grid.

This thesis starts with the observation that the energy performance of residential smart grids at the low-voltage level theoretically depends on four aspects namely: technical, financial, human and societal aspects (Reinders et al., 2012). From this point of view, an interdisciplinary design approach focused on these aforementioned aspects is expected to create better solutions compared to approaches aimed at optimizing technical solutions only.

Human aspects refer to user context and users' interaction and expectations with respect to smart grids products and services. Considering that end-users play an important role in the functioning and acceptance of new energy solutions in smart grids, the main research question addressed in this study is formulated as follows:

What design-related insights should be taken into account in the design and development of future residential smart grid projects, products and services in order to facilitate a more active participation of end-users in a smart grid?

The sub-questions, which helped to approach the main research question in a systematic and logical way, were:

- 1) What is the existing knowledge from literature on end-users of smart grids, current smart grid products and services for households and stakeholder involvement in smart grids?
- 2) How do smart grid stakeholders assess the development and performance of residential smart grid projects, and the products and services that are part of the projects?
- 3) What insights can be gained from evaluating current residential smart grid projects from a user perspective, in particular with regards to the energy performance of products and services implemented in these projects?
- 4) How can design interventions support the development of new products in future smart grid households?
- 5) Which functionalities do end-users prefer with regards to new products and services for smart grid households?

Each chapter in this thesis addresses one of these sub-questions. As such this summary will show findings related to these five sub-questions in a chapter format.

In Chapter 2, sub-question 1 is explored:

“What is the existing knowledge from literature on end-users of smart grids, current smart grid products and services for households and stakeholder involvement in smart grids?”

This is done by a literature study on the involvement of end-users and stakeholders in smart grid projects. In Chapter 2, information about current experiences with existing smart grid products and services in residential smart grids is also presented. This chapter specifically focuses on the participation of end-users in smart grids deployment, namely to what extent the wishes and input of end-users are taken into account in current smart grid initiatives, and how current smart grid products and services have supported an active role for end-users in residential smart grid projects.

Chapter 2 highlights the need for a better end-user involvement for the successful development and deployment of smart grids. This is particularly regarding the development of products and services. Literature review showed that end-user involvement is still very much limited, with smart grids deployment mainly focused on

technological issues and economic incentives. The review showed that currently, end-users have been largely considered as passive participants in smart grids development, with their involvement being largely limited to influencing their energy behavior to support electricity demand and supply balancing in the electricity grid. However, the importance of supporting end-users as co-providers or energy citizens in the electricity system was emphasized in literature. But, limited insights exist from literature regarding how this co-provider role has been or could be facilitated in practice.

An important aspect of end-user involvement in smart grids is the way end-users interact with smart grid products and services. Given the limited interaction between end-users and current products and services, the literature review showed that current products and services have not always supported an active role for end-users in smart grids. Therefore, several authors have mentioned that design could play an important role in improving the involvement of end-users in smart grid development (e.g. Geelen et al., 2013a, Kobus et al., 2012). The literature review affirmed the relevance of a better end-user and stakeholder involvement in smart grids development.

Chapter 2 also shows that limited information existed with regards to the end-user and stakeholder involvement in smart grids development at the low voltage household and residential areas. It is still not clear from literature on how end-users are currently involved in smart grids, or how they can be supported as co-providers. Only a handful of studies (e.g. Geelen et al., 2013a, Kobus et al., 2012) have explored the role of users as co-providers in a smart energy system. These explorations have, however, been limited to individual pilot projects at the very early stage of implementation, a small group of residential end-users involved in these pilots, or specific products such as small smart appliances or energy monitors, or the use of mainly exploratory approaches such as interviews.

To conclude, the literature review in Chapter 2 shows that a research gap exists between the active involvement of end-users, and the design processes of smart grid pilots and related energy products and services. These findings necessitated a further field exploration regarding the development and performance of residential smart grid projects, including products and services implemented in these projects. Subsequently in Chapter 3, sub-question 2 is explored:

"How do smart grid stakeholders assess the development and performance of residential smart grid projects, and the products and services that are part of the projects?"

This is done by evaluating the views and perceptions of a broad range of smart grid stakeholders regarding the set-up and implementation of residential smart grid pilot projects. Hereby, attention was paid to the involvement of stakeholders and end-users, the performance of residential smart grids, and products and services that may support an active participation of end-users in smart grids. This exploration became necessary because of the limited information available regarding the development and performance of residential smart grids projects, and current products and services.

Semi-structured interviews were conducted with nine (9) stakeholders involved in the set-

up and implementation of five different Dutch residential smart grid pilot projects. These stakeholders included electricity network operators, energy suppliers, and end-users from individual households and local energy cooperatives.

The Strategic Niche Management (SNM) processes for building of social networks and learning in innovations was employed as a framework to study the development and performance of residential smart grids.

This study showed that the European Union, national, provincial and municipal governments, grid operators, energy suppliers, household end-users, product and service suppliers, Information and Communication Technology (ICT) companies, knowledge institutes and local energy cooperatives are currently involved in residential smart grid pilots. The interviewed stakeholders stated that end-users are key for a successful development and implementation, confirming the insights gathered in Chapter 2.

With regards to the development of smart grid products and services, this chapter reveals a technology-push approach, and a lack of integrated approaches in smart grids products and services development. The perspectives of the technical partners involved in the projects appeared to be the starting point in the development of these products and services. This mainly top-down approach supported the creation of very functionally attractive, but rather technically complex products and services that end-users do not always easily understand and interact with. Distribution System Operators (DSO's) or grid operators appear to be the leading players in the development and implementation of residential smart grid projects. This is because of their interest in reducing future costs related to expanding the electricity infrastructure, and finding the best ways to facilitate demand side management at the end-user level.

It was found that the complexities reported in existing smart grid products could be attributed to the set-up of residential smart grid pilot projects, and current approaches in developing the products and services offered in these projects; namely a dominantly technical approach originating from the fields of electrical engineering, power systems and digital technologies has been the basis for the development of these products and services.

The perspectives of the technical partners involved in residential smart grid projects, such as grid operators, energy suppliers and product and service suppliers, were mainly the starting point of the development of these products and services such as HEMPs.

Based on the study conducted in this chapter, it can be concluded that learning processes in residential smart grids are still very much focused on developing and testing of various smart grid technologies, but to a lesser extent on how to 'co-shape' technology innovations in smart grids with potential users from an early stage. We therefore recommend that a better alignment of technology development and the user contexts and environment would be required for future innovations leading to better smart grid products and services.

Furthermore, in Chapter 4, sub-question 3 is explored:

"What insights can be gained from evaluating current residential smart grid projects from a user perspective, in particular with regards to the energy performance of products and services implemented in these projects?"

This study presented in chapter 4 aimed to fill the gap related to the limited knowledge

available regarding the participation of end-users in residential smart grid projects, and the energy performance of households in smart grid projects with strong user involvement.

In this study, two residential smart grid projects, PowerMatching City, Groningen (NL) and Pecan Street, Austin Texas (USA) have been compared regarding their energy performance and the experiences of users in these projects. The objective of the comparison was to gain new insights that could support the successful deployment of future residential smart grids. Measured data on electricity generation and electricity consumption of households in 2013 and 2014 were evaluated. Existing reports with results of surveys of users were analyzed as well.

The energy performance, which is based on households' energy consumption and generation patterns showed a large difference in the electricity consumption and generation patterns of households in the PowerMatching City and Pecan Street; namely the average domestic electricity consumption of households in PowerMatching City was lower compared to Pecan Street (2.6 GW h versus 10.1 GW h). Higher average temperatures in Austin, and the usage of air-conditioning systems, appeared to have mainly influenced the electricity consumption patterns in Pecan Street, and hence can explain the high electricity consumption.

At the same time, households in Pecan Street generated a higher amount of electricity compared to PowerMatching City (6.8 GW h versus 1.14 GW h). In 2013 and 2014, the electricity generated by households in Pecan Street was about 5 times higher compared to the generation in PowerMatching City. While the summer months accounted for the highest electricity generation in both pilots, the lowest energy generation occurred in the autumn and winter months. The higher solar irradiance and average installed power of distributed generating energy technologies, such as solar photovoltaics were the major influencing factors for the higher electricity generation in Pecan Street.

In general, participating households in both pilots consumed less energy than the average households in Austin and in Groningen. The participation of the households in the projects appeared to have supported an increased awareness in energy utilization. Households in Pecan Street consumed on average 8% less electricity with respect to the USA average household domestic electricity consumption of 10.9 GW h; while households in PowerMatching City consumed 19% less electricity compared to the Dutch average household domestic electricity consumption of 3.1 GW h.

Households in PowerMatching City appeared to have a higher potential to contribute to electricity demand and supply balancing, because their electricity consumption from the grid was largely reduced with increased self-generation. Also, the energy performance of households in PowerMatching City appeared to have improved with the implementation of the smart grid technologies.

Comparing the design and set-up of the PowerMatching City smart grid project in Groningen (the Netherlands) and Pecan Street smart grid project in Austin (USA), it is observed that the way participants were involved in the projects was quite similar. End-users in both projects also had similar characteristics, such as high income and educational level, and motivation to participate in smart grid projects. However, a

difference was observed in the involvement of participating end-users in the development of the implemented products and services. While participants in PowerMatching City took part in the development of elements of the Home Energy Management Systems (HEMS), participants in Pecan Street mainly provided feedback to pre-determined HEMS tested in their homes.

A comparison of user experiences highlighted similar insights regarding the use of implemented technologies. Another important insight from user experiences in both projects is related to the use of manual and automated technologies. End-users in both projects had preference for technologies that automatically shift their energy use. This is because these kinds of technologies require minimal effort to operate. Most of the participants in both projects express satisfaction with the smart energy system in place, which increased their awareness and consciousness of their energy behavior. Though an effective use of smart energy products such as programmable thermostats could support efficient-energy behavior in the participating households, most participants in both projects were not always capable of using the implemented technologies, such as smart programmable thermostats. This study showed that in most cases, end-users have difficulties comprehending the feedback provided by these products. Insights from this study showed that the interaction between end-users and new energy technologies still remains challenging.

With regards to the energy performance of the households participating in both projects, this study concludes that existing smart grid set-ups, local climate and related needs for heating and cooling, the average capacity of installed energy generating technologies and the prevailing energy behavior largely influenced the pattern of households' electricity generation and consumption. Most importantly, the study confirmed that the interaction between end-users and current smart grid technologies still remains a challenging task.

Considering the potential benefit of design in stimulating a better end-user interaction with smart grids products and services, (as pointed out in the literature review), consequently, in Chapter 5, the 4th sub-research question is explored:

"How can design interventions support the development of new products in future smart grid households?"

The development and introduction of Home Energy Management products (HEMPs) will be required to support a more active involvement of end-users in household energy management, especially in a smart grid context.

The previous chapter established that interaction between end-users and current smart grid technologies still remains a challenging task. Insights from Chapter 2 suggested that design could potentially support the design of better products, reduce complexities associated with current smart grid products and services, and increase the acceptance by end-users. A study carried out by Reinders et al., (2013) proposed that a closer insight in energy technologies in relation to appropriately matched design processes could support a better embedding of energy technologies in industrial product design, and therefore lead to more optimal products and services.

Given the potential role of design in the success of products and services for end-users, sub-question 4 evaluated the role of Industrial Design Methods (IDMs) in the design and

development of new innovative smart grid related product concepts at the household level. In this regard, 10 IDMs were applied to design and develop new Home Energy Management Products (HEMPs) for households in a students' design project executed at the University of Twente in 2013 and 2014.

This evaluation revealed that 4 IDMs namely: Platform-Driven Product Development (PDPD), Delft Innovation Method (DIM), Theory of inventive problem solving (TRIZ), and Technology Roadmap (TRM) were predominantly used in developing the conceptual HEMPs. These IDMs provided a structured approach that supported the implementation of the most relevant aspects for an integrated development of the conceptual HEMPs. DIM was employed mostly at the start of the design process to explore what the best fields of interest might be in terms of HEMPs. TRM supported the choice of the most promising technology directions. TRIZ supported the anticipation of problems and contradictions during the design process and PDPD aided the incorporation of modularity in the product design.

The sequential application of these IDMs helped to identify and incorporate technological, societal, end-user aspects, and market opportunities in the design of the innovative product concepts presented in this study.

In general, the application of IDMs in the design projects supported a detailed exploration of technological possibilities regarding smart energy products, and the opportunities that exist in the energy market regarding end-user preferences. This further highlights the importance of not only focussing on the technology aspects, but also markets, and human aspects relevant for the successful design of new smart energy products.

Additionally, in Chapter 5, the 5th sub-research question was also examined:

"Which functionalities do end-users prefer with regards to new products and services for smart grid households?"

This sub-research question focused on the evaluation of the Home Energy Products developed in the students' design project, as well as commercial HEMPs currently available in the market. This evaluation focused on end-users' perceptions of and preferences for existing and new conceptual HEMPs, and the functionalities of these HEMPs they may best stimulate energy-efficient behavior. An online questionnaire survey was utilized for data collection.

Three types of HEMPs namely smart thermostats, smart plugs and smart wall sockets, have been analyzed. An interesting observation was that end-users preferred the same features for both the existing and new conceptual HEMPs. For both the existing and conceptual products evaluated in this study, the smart thermostat emerged the most attractive and favourite product, and the product with the greatest potential to stimulate energy-efficient behavior in households. This is due to its ability to provide the most comprehensive insight in households' energy consumption and generation. It was also seen as a more complete solution compared to the smart plug and the smart wall socket that focuses on the electricity use of specific household appliances connected to them.

This study concludes that HEMPs that make energy use most visible to end-users, that could be remotely controlled and which require minimal effort to operate, may best

stimulate energy-efficient behaviour in households.

In addition to these features, it was also remarkable to observe that design appearance also seemed to have influenced the preferences of end-users regarding specific HEMPs.

This study, therefore, confirmed that new design features have an influence on user perception of HEMPs. Also, our study revealed that end-users would prefer HEMPs that combine information about various household energy generation and use to HEMPs that measure and report the energy use of separate household appliances.

The findings of this chapter supplement the emerging but limited body of smart grid literature by highlighting the main features that household end-users desire products that could stimulate energy-efficient behaviour, and with particular emphasis on the transition to smart grids. Specifically, this survey has provided an improved understanding of how consumers perceive current smart energy products aimed at supporting household energy management. Since there is still significant progress to be made in the development and implementation of HEMPs, insights from this study could support improved designs and development of future HEMPs because intermediary products such as user interfaces are important in ensuring a more active involvement of end-users in household energy management.

Based on the findings from the individual chapters, several recommendations that could support the design and development of smart grid products and services are proposed.

The overall research question addressed in this thesis is formulated as follows:

What design-related insights should be taken into account in the design and development of future residential smart grid projects, products and services in order to facilitate a more active participation of end-users in a smart grid?

In order to answer this question, the findings from sub-questions (chapters) are pulled together to provide recommendations that could support the deployment of residential smart grids and the design and development of smart grids related products and services.

It is recommended to employ a more integrated approach where end-users and other relevant stakeholders cooperate better in the deployment of residential smart grid projects, and in the development process of associated products and services. This is the result of complexities reported with existing smart grid products and services, which in most cases make end-user acceptance and adoption of smart grid products and services challenging.

Participatory design or co-design approaches could be beneficial in aligning end-user interests with the interests of the other stakeholders especially at the early stages of smart grids product and service development, thereby eliminating complexities in present and new to be developed products and services.

This thesis shows that in the future, several Home Energy Management products aimed at saving energy or increasing end-users' awareness of energy consumption will emerge.

We recommend the inclusion of the end-users in the design process to enable them contribute valuable insights for the development process.

Another recommendation is related to either providing complex (high technology) solutions for end-users or simple (low technology) solutions. We propose the development of both easy to use and comprehensive solutions to enable end-users to manage and control their household energy generation and consumption better. It is therefore important to develop tools that match the knowledge and experiences of different end-user groups. The low technology solutions should be developed for the category of end-users that have little technical experience, while the “techies” or those that have profound interest in high technologies should be provided with these kinds of technologies.

This recommendation is based on the affirmation of the existence of different end-user segments with different needs and abilities. This thesis demonstrates that while certain users would prefer simple interfaces with limited information, others require products that provide comprehensive insights in their energy consumption and generation.

Currently, limited services exist that support end-users in the usage of various technological products. This thesis shows that various products and services would be required to support an active participation of end-users in the future energy system. These include products and services that provide insight in energy generation and consumption of households, show usage patterns of household devices and prices of electricity in the grid, enable manual programming of smart appliances, and enable end-users to compare their energy usage with other households. We therefore advocate that designers and developers of smart grid products and services for households take into account the particular end-user category they are targeting. For instance, particular groups such as young or old people, technical and non-technically inclined people should be targeted in the development of future products and services. These various end-users should be carried along in the design and development of various products and services. For future large-scale development of smart grids at the local (household and neighbourhood) level, more emphasis should be placed on developing products and services on a small scale, focussing on specific user segments. In this regard, design and co-creation approaches could support the creation of successful products with a better performance than the existing.

Product and service designers should aim at developing integrated products and services with increased modularity, which allows new services to fit easily and improving the ability to meet various end-user needs. This suggestion is the result of the lack of standardized products, and limited interoperability between existing products and services.

We advocate that design and styling aspects are incorporated. The findings from this thesis highlights that design features could have an influence on how end-users perceive and utilize Home Energy Management Products (HEMPs) in achieving their energy-related goals. For instance, the evaluation of the conceptual smart plug in chapter 5 showed that end-users had more preference for the conceptual smart plugs, which appeared to have more intuitive design features than the existing commercially available smart plug.

Finally, it is recommended that smart grid set-ups employ a user-centred approach in the design and implementation stages. This approach will support the development of improved, more simplified, intuitive and user-friendlier smart grid products and services. This user-centred approach will support a better incorporation of the wishes and demands of end-users in the design and development of future smart grids products and services, and stimulate more active participants in future smart grids.

To achieve broader societal embedding of smart grid products and services, it is suggested to involve end-users better in the design and development of these products and services from the onset, and not to use them only as sources of market information or to adjust pre-determined products and services. This approach will ensure a more active participation of end-users and enable the behavioural change required from end-users in order to balance electricity demand and supply balancing in the grid. We therefore recommend that a better alignment of technology development and the user context or environment would be required for future developments leading to better smart grid products and services.

Chapter 1 Introduction to smart grids research

1.1 General introduction

The global energy environment is constantly changing. Our modern society still largely relies on fossil fuels as the primary energy source. Countries and regions across the globe are currently confronted with issues related growing energy consumption, increased demand, and security of supply. Most importantly, climate change concerns are on the rise. As a result, our modern society will experience an energy transition from fossil fuels to more sustainable and renewable forms of energy in the coming decades.

This introductory chapter describes the reason why the research presented in this thesis has been executed, describing the background to the research, as well as the set-up of the research, and the outline of the thesis.

Therefore, this chapter is structured as follows. In Section 1.2, the energy transition to decentralized electricity system and the concept of smart grids is presented. Next in section 1.3, current issues regarding energy demand and supply are discussed. In Section 1.4, the consequences of the transition to renewable energy use are described. Section 1.5 describes smart grids in residential areas, including current products and services that enable end-users of electricity to play a more active role in smart grids.

1.2 Energy transition to decentralized electricity system and smart grids

Our energy provision system is dynamically changing by a continued increase in energy demand, and scarcity of fossil fuels (IEA, 2012; IEA, 2016; IPCC, 2015). The continuous increase in energy use could imply that in a hundred years, fossil fuels may not be able to secure the world's future energy demands for transport, heating, and electricity (IPCC, 2015). Also, there exist concerns about the effects of greenhouse gas (GHG) emissions mainly from fossil fuel combustion (IEA, 2012; IEA, 2016; IPCC, 2015).

Current trends in energy demand and supply have put energy generation and use at the center of the climate change debate (IPCC, 2015; IEA, 2016). Various world regions and governments have, therefore, proposed policies and programmes aimed at ensuring future security of energy supplies and reducing GHG emissions (IEA, 2012; IEA, 2016; IPCC, 2015). For example, the European Union (EU) countries, the United States and Asia have defined emissions reduction goals, or Intended Nationally Determined Contributions (INDCs), under the United Nations Framework Convention on Climate Change (UNFCCC) (UNFCCC, 2016).

The EU's commitment to substantially reduce CO₂ emissions before 2030 entails, among other things, that more electricity must be generated from renewable power sources, such as wind, water and solar energy. In line with the EU targets, the Dutch government,

in 2013, signed an energy agreement that aims at limiting the use of fossil fuels by shifting to a more sustainable energy system (SER, 2017).

The transition to a sustainable energy system will support an increase in small-scale distributed energy systems especially in low voltage grids, which are common in residential areas (Kobus et al., 2012). A large part of the electricity supply in these areas are continuously being generated by various decentralized energy resources like wind turbines, photovoltaic (PV) solar systems and micro cogeneration systems. In recent years, renewable energy technologies like PV solar systems and wind turbines have become mainstream in most countries due to dramatically falling prices (Kobus et al., 2012; Greenpeace, 2016; UNEP, 2016). PV solar systems and wind turbines are also projected to become the cheapest ways of producing electricity in many countries during the 2020s and in most of the world in the 2030s (Bloomberg, 2016). Onshore wind costs and solar PV costs are projected to fall by 41% and 60% respectively in 2040 (Enerdata, 2016).

In the Netherlands, the amount of PV systems on roofs of households has continued to grow strongly (CBS, 2016). The number of Dutch households with solar PV installations increased from about 160 thousands in 2014 to 300 thousands in 2016 (CBS, 2016; ECN et al., 2016). The total capacity of PV systems therefore increased from about 600 MW to 1400 MW in three years' time (CBS, 2016). Figure 1 shows the trend in installed capacity of PV solar between 1990 and 2015 in the Netherlands.

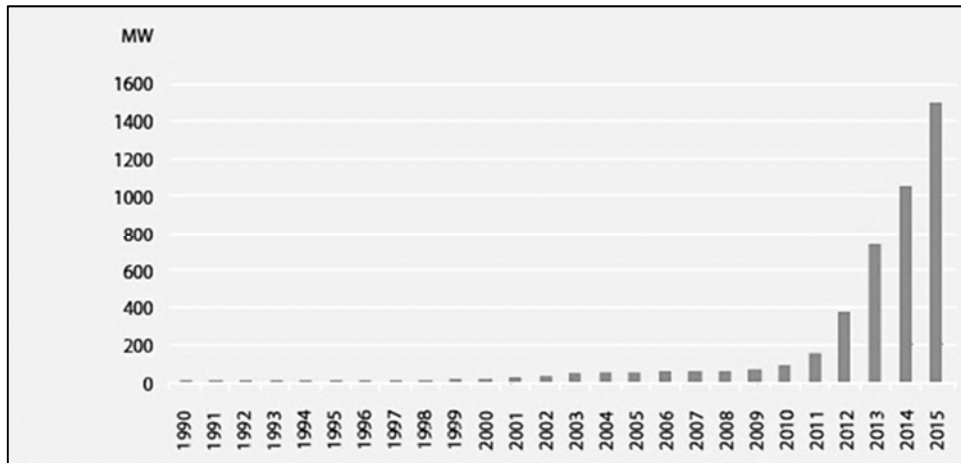

Figure 1.1. Installed capacity of photovoltaic (PV) systems in the Netherlands
Source: CBS, 2016

The number of wind turbines on land, and the installed capacity of wind energy in the Netherlands have also strongly increased since 1990. The installed electric capacity of wind turbines grew by an average of 19% per year, to 2713 MW, between 1990 and 2013 (CBS, 2016). The increase in renewable energy technologies was partly supported by a subsidy scheme known as 'Stimulerend Duurzame Energieproductie', which was introduced in 2008 (NL Agency, 2013; RVO, 2016).

However, increased decentralized electricity generation from intermittent renewable energy sources causes a complexity to balance demand and supply in the electricity network. Specifically, decentralized electricity generation leads to larger peaks and fluctuations in electricity demand and supply balancing in the electricity network. These peaks make the management of the network more complex (European Commission, 2016). This difficulty is one of the reasons why electricity grids are currently being transformed into more intelligent electricity networks, referred to as 'smart grids' (Toft, 2014). In a smart grid, electricity production and consumption is coordinated to maintain balance and optimize productions and distributions. This coordination is possible because smart grids make use of information and communications technology (ICT) to match electricity demand to supply conditions more efficiently (IEA, 2011; Netbeheer Nederland, 2012). A scheme representing a smart grid system is shown in Figure 1.2.

Several definitions of smart grids have emerged in recent years, by various reports and studies (IEA, 2011, ETPS 2011, Netbeheer Nederland 2012). Giordano et al. (2011) describe smart grids as upgraded electricity networks that enable two-way information and power exchange between suppliers and consumers. The Dutch grid operator association (Netbeheer Nederland), describes a smart grid as a grid with advanced technologies that is able to inform about electricity flows and grid conditions, and which facilitates controllability of electricity flows to assist the energy transition" (Netbeheer Nederland 2009). The European Technology platform smart grids (ETPS, 2010 pp. 6), defines a smart grid as:

"an electricity network that can intelligently integrate the actions of all users connected to it – generators, consumers and those that do both – in order to efficiently deliver sustainable, economic and secure electricity supplies".

The definition of smart grids given by ETPS (2010) will be used as a reference in this study, since it emphasizes the technical aspects related to developing the electricity infrastructure, the energy market and interaction with the end-users.

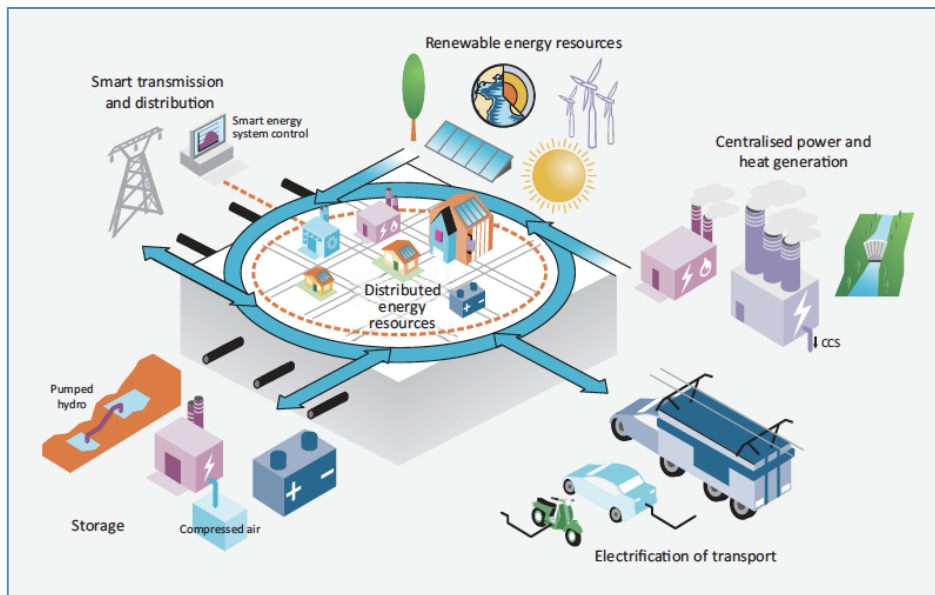

Figure 1.2. Schematic presentation of a smart grid system
 Source: IEA, 2014

The systemic shift towards a decentralized and more sustainable energy future is termed the energy transition (Loorbach and Verbong, 2012). Smart grids are considered a promising solution that will support the energy transition, and a more efficient use of renewable energy and the existing electricity infrastructure (Kobus, 2015; Agentschap, 2013). It is therefore a key to demand and supply-side management of energy systems (IEA, 2011; Executive office, 2011).

According to NL Agency (2013), smart grids include different developments around the energy infrastructure - mostly the high voltage grid to power grids, the low-voltage grid in the district and the energy applications at the consumer. A scheme developed in the context of the Universal Smart Energy framework will be used to depict the various levels of smart grids deployment (Figure 1.3). The research presented in this thesis focuses on smart grids deployment in low voltage residential areas.

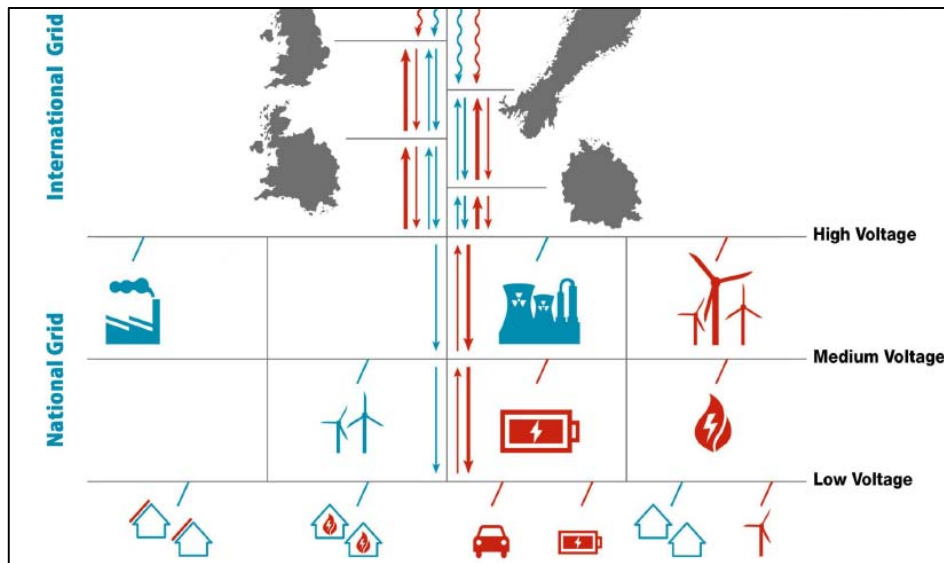

Figure 1.3. Various levels of the electricity grid
 Source: Universal Smart Energy Framework (USEF, 2014)

The transition of the electricity system to smart grids will ensure the reduction of CO₂ emissions from fossil fuels and security of energy supplies in the future (Netbeheer Nederland, 2012; IEA, 2011; Gaviano et al., 2011, Wolsink, 2012).

In the following section, the current situation regarding energy demand and supply will be deeper explored to elaborate why it is necessary to transform existing electricity infrastructures into smart grids.

1.3 Issues regarding energy demand and supply

Global primary energy demand is projected to increase by 35% between 2010 and 2035 (IEA, 2012; IEA, 2016; Greenpeace, 2016; Exxonmobil, 2017; World Energy Council, 2014). This is largely attributed to growth in global economy, rising living standards, and increase in world population (World Energy Council, 2014). According to the United States Energy Information administration's (EIA, 2016) International Energy Outlook 2016, total world energy consumption rises from 549 quadrillion British thermal units (Btu) in 2012 to 629 quadrillion Btu in 2020 and to 815 quadrillion Btu in 2040 - an increase of 48% increase from 2012 to 2040 (Figure 1.4).

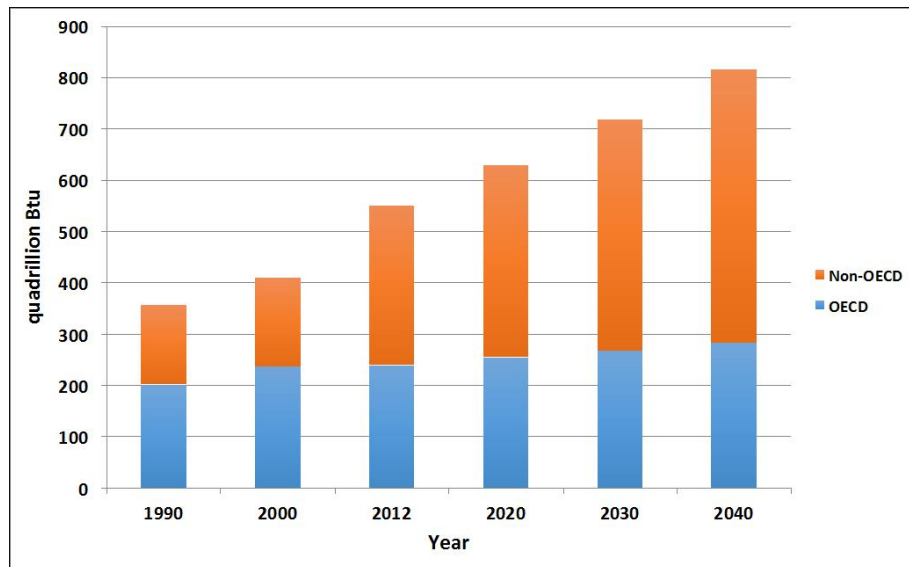

Figure 1.4. World energy demand by region. OECD: Organization for Economic Cooperation and Development, Source: EIA, 2016

Most of the world's energy growth will occur in countries outside of the Organization for Economic Cooperation and Development (OECD), particularly in Asia. Non-OECD Asia, notably China and India, account for more than half of the world's total increase in energy consumption over the 2012 to 2040. This increase in energy use is mainly as a result of strong economic growth and increasing populations. Non-OECD energy consumption increases by 71% between 2012 and 2040 compared with an increase of 18% in OECD nations (Figure 1.5).

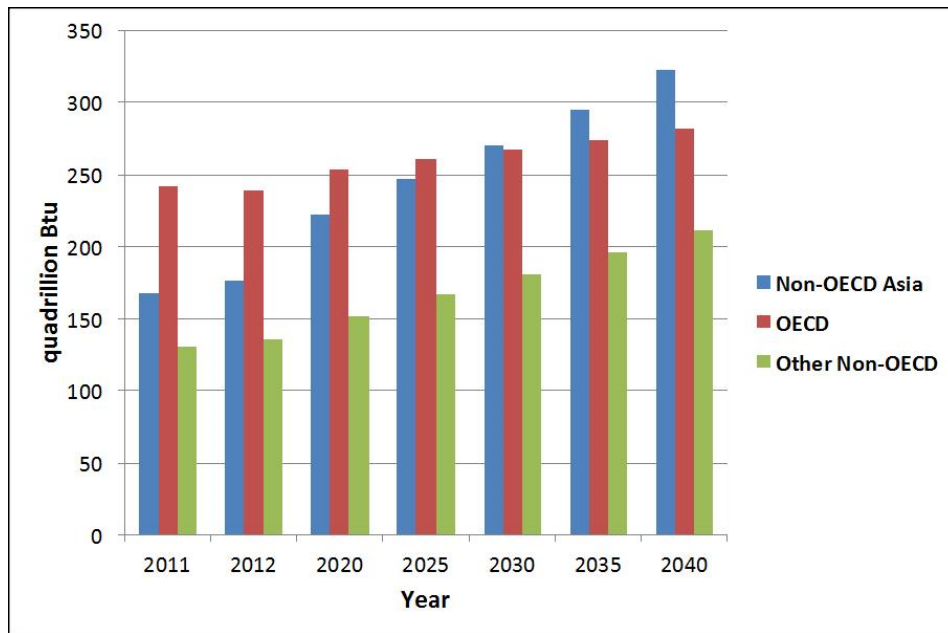

Figure 1.5. World energy demand by region, 2012 to 2040. OECD: Organization for Economic Cooperation and Development
Source: EIA, 2016

Electricity remains the world’s fastest-growing form of energy consumption due to economic growth and development, urbanization, increased digitalization of society, and electrification of transport (IEA, 2014; IEA, 2016; Eurel, 2013; Exxonmobil, 2016). Compared to other sources of energy such as coal, natural gas and biofuels, the electricity share of world residential energy consumption will increase from 39% in 2012 to 43% in 2040 (Exxon Mobil, 2012; IEA, 2016). Increased electricity demand, especially in households will come from the deployment of heat pumps, ventilation systems, home automation and electric car demand (Eurel, 2013; IEA, 2016).

The situation in the Netherlands is identical to the global trend. Although most energy used in the Netherlands is for heating and industrial purposes, electricity use especially in households is increasing (Energy-Netherlands, 2014).

Regarding generation, world total electricity generation is projected to increase by 69% in 2040, from 21.6 trillion kilowatthours (kWh) in 2020 to 36.5 trillion kWh in 2040 (IEA, 2016). The strongest growth in electricity generation is projected to occur among the developing, non-OECD nations (an average of 2.5% per year from 2012 to 2040). In the OECD countries, electric power generation increases by an average of 1.2% per year from 2012 to 2040. This is mainly due to more advanced Infrastructures, and relatively slower population growth. Conventional fossil fuels such as gas, oil and coal still remain the largest source of global energy generation, accounting for around 81.2% of the energy used for heating and electricity (Exxonmobil, 2016; Greenpeace, 2016).

In the Netherlands, electricity generation from renewable energy sources is currently on the rise. However, electricity generation in the Netherlands is mainly based on fossil fuels such as natural gas and coal (CBS, 2015).

Increased demand for energy, and in particular electricity, and the continued reliance on fossil fuels has increased the levels of anthropogenic emissions of carbon dioxide (CO₂). As a result of current trends in energy demand and supply, world energy-related CO₂ emissions is projected to increase from 32.3 billion metric tons in 2012 to 35.6 billion metric tons in 2020, and to 43.2 billion metric tons in 2040 (International Energy Outlook 2016 reference case). This is in turn projected to lead to an estimated increased temperature of 4 to 6 degrees Celsius (IPCC, 2016).

To summarize, our energy provision system is changing by a continued increase in energy demand, scarcity of fossil fuels and calls for climate change mitigation (IEA, 2012). Current energy demand and supply patterns is leading to a change in the current energy provision system from a predominant reliance on fossil fuels to low-carbon technologies, such as renewable energy sources.

The following section will discuss current development regarding renewable energy generation and use in more details.

1.4 Consequences of the transition to renewable energy use

In order to address climate change issues resulting from the current unsustainable ways of energy demand and supply, a transition towards a sustainable energy system, based on renewable energy sources will be required (IPCC, 2015; IEA, 2015; REN21, 2015; Greenpeace, 2015; European Commission, 2016). Various world regions have set legally binding targets aimed at increasing the share of renewables in the energy supply of the future (IEA, 2016).

Renewable energy consumption is projected to increase by an average 2.6% to 2.9% per year between 2012 and 2040 (EIA, 2016; EIA, 2016). Renewables contributed 60% of new power generation worldwide in 2014, and in some countries the share was higher (REN21-2015; Greenpeace, 2016). EU countries have ambitions to increase the share of renewable energy consumption from less than 10% in 2010 to 20-75% between 2020 and 2050 (EC, 2011; EU, 2011; European Commission, 2016; Eurostat, 2015). Renewables are projected to generate 70% of Europe's power in 2040, up from 32% in 2015 (Enerdata, 2016).

Solar is the world's fastest-growing form of renewable energy, with total solar generation increasing by an average of 8.3% per year (Greenpeace, 2016). Renewables' share of electricity on solar energy is expected to increase from 21% in 2016 to 64% in 2040 (Greenpeace, 2016).

In line with the EU targets, the Dutch government, in 2013, signed an energy agreement that aims to accelerate the growth in the share of renewable energy in the energy mix

(ECN, 2016). The agreement proposes to support an increase in the share of renewable energy generation by 14% in 2020 and 16% in 2023 (SER, 2017; ECN, 2016). Despite the Dutch government's commitment to increase the share of renewable energy, renewable energy still plays a small role in the energy supply of the Netherlands (ECN, 2016).

The most recent figures from the Dutch office of statistics show that the generation of renewable energy in the Netherlands increased from 5.5% to 5.8% in 2015 (CBS, 2016). An increased growth in the share of renewable energy is expected in the coming years, mainly due to the energy agreement. Also, there is an increasing number of local energy initiatives in the Netherlands focused on energy production, energy saving and collective buying of solar panels and energy, and the development of collective solar and wind projects.

However, compared to most EU countries, the Netherlands still lags behind in the area of sustainable energy due to the lack of government support for renewable energy sources (CBS, 2016; Eurostat, 2016). For instance, only 5.5% of the Dutch Energy came from renewable sources in 2014. According to Eurostat (2016), renewable energy generation in the Netherlands is far less than the other EU countries such as Sweden (53%), Latvia (39%) and Finland (39%). Also, the EU average is 16% higher than the generation in the Netherlands. The Netherlands only generates more renewable energy than Malta (4.7%) and Luxembourg (4.5%) (Eurostat, 2016).

In recognition of the need to further increase the share of renewables, the Dutch minister of Economic Affairs, Henk Kamp, presented a new energy agenda in December 2016. The agenda re-affirms the government's intention to reduce the use of natural gas by promoting renewable electricity and renewable heat (ECN, 2016; RVO, 2016). This agenda is necessitated partly by concerns over recent incidences of earthquakes, currently experienced in the province of Groningen, where gas exploration activities have been going on for years. The Netherlands has also committed itself to the agreements of the climate agreement in Paris. It will be recalled that in 2015, in the framework of the climate conference COP-21, about 195 countries agreed to make drastic reductions in CO₂ emissions to almost zero in 2050 (UNFCC, 2016). Only a large scale implementation of low carbon technologies will support the achievement of these goals and targets.

Current developments in the energy sector show that an increased amount of energy, mainly electricity, will be generated with renewable energy (Kobus, 2015). However, the intermittent nature of renewable energy sources, such as wind and solar power, poses a challenge to the reliability of the power system. The more renewable energy sources are connected to the electricity grid, the more critical the matching of supply and demand becomes for regulation of the electricity system. As a result of the possibilities and challenges brought by renewables, the energy system is changing to a more sustainable and intelligent energy system known as smart grids, as stated in Section 1.2.

Smart grids are expected to facilitate energy use from various renewable and decentralized electricity generation in the future, the electrification of transport, energy efficiency in households, and a better coordination of energy supply and demand in the electricity grid (IEA, 2012; Wolsink, 2012; ETPS, 2011; Agentschap, 2013).

The research presented in this thesis focuses on smart grids in residential areas. Therefore, the following section will briefly describe the current situation regarding smart grids development in residential areas.

1.5 Smart grids in residential areas

An increased decentralized energy generation mainly from renewable sources, especially at the low-voltage household and residential areas is expected in the future. End-users in these areas will generate electricity using various renewable energy technologies, such as PV systems, small wind turbines and heat pumps (Klein et al., 2010; Ragwitz et al., 2010; Ngar-yin mah et. al., 2012). Smart grids can help to connect energy generation and consumption in real time (DNV Kema, 2013). Smart grids development at the low voltage areas will require more interaction between end-users, their appliances, energy suppliers, and other end-users who will be generating energy from various renewable sources. The role of end-users will change from passive receivers of energy to an empowered and crucial part of the electricity system (Wolsink, 2011; Geelen et al., 2013; Gungor et al., 2012). Various studies have concluded that end-users have a major role to play in the introduction of smart grids and associated technologies (IEA, 2012; Ngar-yin Mah et al., 2012; Gangale et al, 2013). In Chapter 2, these studies will be presented in more detail.

Smart grids also create the possibility to develop new energy-related products and services, which have the potential to facilitate a more energy-efficient behaviour in households, local production and a better utilization of sustainable electricity, trading of electricity with the low voltage grid; thereby supporting the balancing of energy demand and supply in the electricity network (Nye et al., 2010; Gungor et al., 2012; Kobus, 2012; Reinders, 2012; Geelen et al., 2013).

From a user perspective, smart grid products and services can be classified as: micro-generators, energy storage systems, smart appliances, smart meters, dynamic pricing and contracting, and energy monitoring and control systems (Geelen et al., 2013) (see Table 1). In Chapter 3, these products and services will be presented in more detail.

An active end-user participation in smart grids will also involve interaction with the various smart grid products and services that could support energy efficiency in households. In this regard, the need to focus more attention on a better end-user involvement in smart grids development has been emphasized (Kobus et al., 2012; Verbong et. al., 2012; Geelen et al., 2013). Also in Chapter 2, active end-user participation will be elaborated. In this study, end-users are referred to as consumers and households at the household or residential areas that generate electricity through renewable energy technologies, individually or collectively.

Table 1.1. Categorization of smart grid products and services.

Source: Geelen et al., 2013.

Products and services	Examples	Function
Microgenerators	Photovoltaic solar panels, heat pumps, wind turbines, Micro – cogeneration units (μ CHP)	Enable households to generate their own electricity
Energy storage systems	Lithium ion batteries, electric vehicles (storage in batteries)	Support the use of energy at different times than when it was generated or purchased from the electricity network
Smart appliances	Smart washing machines, dishwashers	Operate at periods that are most suitable for the electricity network (abundance of renewably generated electricity, off-peak periods)
Smart meters and Advanced Metering Infrastructure (AMI)	Smart meters and Advanced Metering Infrastructure (AMI)	Measure household electricity consumption and production and communicate these data to the energy supplier
Dynamic pricing and contracting	Time variable pricing, Time-of-use (TOU), Critical Peak Pricing (CPP), Real time pricing (RTP)	Provide information of varying electricity costs, in order to stimulate households to use energy at times most favourable for the electricity network
Energy monitoring and control systems	In-home displays	Visualize, monitor and manage household energy (electricity, water and gas) and consumption

This thesis focuses on smart grid products and services that end-users can interact with. This will be referred to as **Home Energy Products or HEMPs**. Kobus et al. (2012) referred to these HEMPs as smart energy technologies, which aim at reducing or shifting energy demand of household end-users. Examples include Energy Management Systems (EMSs) and smart appliances.

In recognition of the need to better involve end-users in energy management in a smart grid, various smart grid projects focusing on consumer engagement have been initiated in Europe and in the Netherlands (Gangale et al., 2013). According to the Joint Research Council smart grids of the European commission, most of the projects focus on the residential sector because of the need for energy providers to target household consumers. Residential consumers represent a huge potential for energy savings that energy providers can harness (JRC ER, 2013). In the Netherlands, the Dutch ministry of Economic Affairs subsidizes these pilot projects through the Innovation Program Intelligent Networks (IPIN) (Agentschap, 2013).

The following sub-section will explore current developments regarding smart grid projects in residential areas.

1.5.1 Smart grid pilot and demonstration projects

Smart grid projects are considered a first step before a large-scale implementation of smart grids in the future, as they help to bridge the gap between technology development and implementation (Geelen et al., 2013; Gangale et al., 2013). Currently, various smart grid projects are taking place at the low-voltage household and residential areas in Europe, Asia-pacific regions (namely Korea, Japan, China, Australia and New Zealand), and the United States of America (USA) (DNV KEMA, 2012). A difference, however, exists regarding the focus of smart grid projects. For instance, in the USA, there is a strong focus on peak load reduction technology and dynamic pricing tariff using Advanced Metering Infrastructure (AMI) and Distribution Automation (Executive Office, 2011). This is due to the high-energy consumption, and lower reliability of the grid compared to Europe (DNV GL, 2014). In the Asia-Pacific region the focus is mainly on demand response for peak reduction and testing different price tariffs, and the roll out of smart meters (DNV GL, 2014). The drivers vary from country to country – from modernizing and improving grid reliability in China, to techniques for load management in Australia and New Zealand (DNV GL, 2014).

In Europe, the main reason for smart grids implementation is the increasing amount of renewably generated energy, and decentralized electricity systems in which consumers have become “prosumers” who both produce and consume electricity (Potter et al., 2009). Emphasis is placed on improving energy efficiency and reducing emissions through the use of more decentralized means of production (DNV KEMA, 2012).

In the last few years, smart grid initiatives with various aims and results have been growing in number and scope all over Europe (Netherlands Ministry of Economic Affairs, 2010; Giordano et al., 2011; Gangale et al., 2013; European Commission’s Joint Research Center, 2014). A comprehensive inventory of smart grid and smart metering projects in Europe for 2014 was carried out by the Joint Research Center of the European Commission (JRC EC, 2014). The inventory revealed about 459 smart grid pilot and demonstration projects launched between 2002 and 2014 (JRC EC, 2014). These include 210 research and development projects, and 250 demonstration projects, involving about 1670 organizations and 2900 participants in 47 countries. The total investments in the European smart grid sector is about €3.15 billion. About 238 projects were completed in 2014, while 221 are still on-going. While Denmark stands out in terms of research and development and demonstration projects, Italy is leading in the smart meter rollout (JRC EC, 2014).

In the Netherlands, an increase in the number of smart grid pilot projects has also been witnessed since 2008. Currently, there are more than 30 Dutch pilot projects being carried out (Netbeheer Nederland, 2016). While some have been completed, some are still being

executed. Figure 1.6 shows the locations of some of the smart grid pilots in the Netherlands, which focus on consumer engagement.

In these smart grid pilot projects, new energy-related products and services have been developed and field-tested, including experiments with innovative energy services in participating households. These new products and services in households are target at enabling households to take part in the management of the electric power grid (Geelen et al., 2013; Gangale et al., 2013; JRC EC 2012; JRC EC 2014; Obinna et al., 2013).

Table 1.2. Locations of some of the smart grid pilots in the Netherlands focussing on consumer engagement.

Pilot	Household numbers	Typical set-up	Parties involved	Year of implementation
1) Powermatching city Groningen	40	Electric Vehicles, hybrid heat pumps, in-home energy displays, powermatcher software, photovoltaic systems, smart meters, smart appliances, smart thermostats, micro-combined heat and power (CHP) systems, wind turbine, mini gas turbines, electricity storage, automated meter reading	Grid operator, knowledge institutes, energy consulting company, ICT software company, gas company, service provider, energy supplier	2007- 2015
2) Entrance Groningen	Not applicable	EVs, Photovoltaics (PVs), battery storage, fuel cell gas, heat pumps	Construction company, Gas infrastructure company, Universities and knowledge institutes	2011-present
3) Cloud power Texel	300	HEMS, wind turbines, PVs, Smart meters, in-home display (kies), cloud power, micro CHPs, cloud power (energy matching)	Energy supplier, product and service supplier, Grid operator	2012-2015

		software)		
4) City of the sun Heerhugowaard	200	PVs, wind turbines, battery, smart appliances	Grid operator, energy supplier, ICT companies, municipal government, energy consultancy company	2015-present
5) Jouw Energy moment zwolle and Breda	250	Smart meters, Energy computers with special software, PVs, web app, Smart Grid, smart appliances (washing machines, dryers)	Grid operator, knowledge institute, product suppliers, housing company, energy supplier, local energy cooperative	2012-2015
6) Amsterdam smart city	Various initiatives	PVs, battery storage,	Grid operators, Universities, Energy consultancy	2009- present
8) Smart grid rendement voor iedereen Utrecht and Amersfoort	200	EVs, PVs Heat pumps, electric vehicles, in-home electricity storage	Universities and knowledge institutes, Municipal government, Grid operator, ICT company, Energy consultancy company, Product supplier, Energy supplier, local energy cooperative	2012-2015
9) Smart grids Lochem	170 members	EVs, PVs, smart meters	Local energy cooperative, Product supplier, University, Grid operator	2012-2015
10) Couperus smart grids Den haag	295	Heat pumps, thermostats, powermatcher	Energy supplier, Research institute, Product and service supplier	2012-2015

			ICT company Housing corporations, Provincial government	
11) Smart grids Heijplaat Rotterdam	180	Smart thermostats, PVs	Grid operator, energy supplier, housing corporation, Nature organization	2012-2015
12) All electric Gorinchem	50	Heat pumps, PVs, battery systems, in home automation	Grid operator, Telecommunications company, Building and construction company, ICT company	2014-present

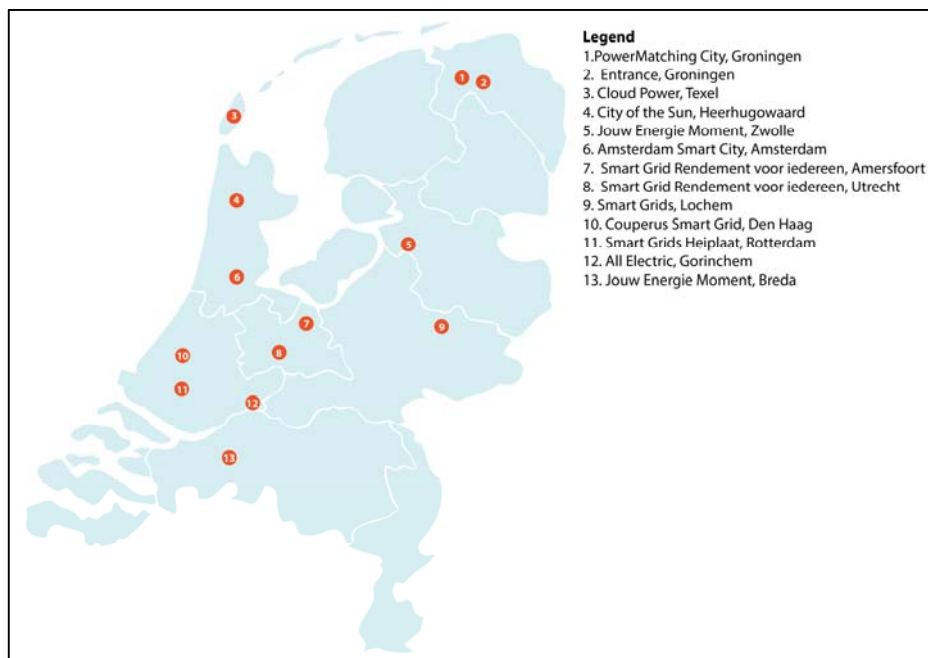

Figure 1.6. Location of smart grids pilots in the Netherlands

Source: Netbeheer Nederland, 2016

In the Netherlands, the 'Top consortium on Knowledge and Innovation' (TKI) Switch2SmartGrids (S2SG) is one of the seven TKIs within the Dutch Top Sector Energy,

that stimulates smart grids research and development and demonstration projects in the Netherlands (Agentschap, 2013). Various stakeholders, such as grid operators, smart grid project developers and managers, and residential end-users are involved in smart grid projects taking place at the low-voltage household and residential areas in Europe and the Netherlands. These stakeholders have a major influence on the set-up of new smart grid pilots and the selection of smart energy products used in these pilots.

It is also of importance to note that these stakeholders have also historically not worked together, hence the need for extensive collaboration to determine what respective roles they will play, and how their various interests can be incorporated in the deployment of smart grids (Agentschap NL, 2012). This collaboration will help to develop the needed technical, financial and regulatory solutions that enable the potential of smart grids (Agentschap 2012; JRC European commission 2011; World energy council, 2012).

1.6 Problem statement

From a theoretical point of view, the energy performance of smart grids at the low-voltage household and residential areas could depend on four factors (Reinders et al., 2012):

- a) technical aspects, such as the design and actual functioning of the energy system
- b) financial aspects, such as investment costs; and financial revenues, costs of electricity, benefits, incentives and taxes
- c) human aspects, such as the interaction of end-users with smart energy products and end-user behavior towards energy-efficiency and users' experiences
- d) societal aspects including regulations and laws regarding electricity tariffs and the use of grids as well as environmental regulations

Although previous studies and reports (Executive office, 2011; ETPS, 2011; Geelen et al., 2013) have concluded that requirements and solutions of end-users could direct the development of smart grid related products and services, so far human aspects have been given little attention in smart grids development and implementation (Verbong et al., 2012). This is the result of the predominant focus on technology development and financial incentives (Geelen et al., 2013; Verbong et al., 2012). A review of worldwide smart grids initiatives revealed the existence of many smart grid projects that mainly focus on technical implementation of systems that balance energy demand and supply (Obinna et al., 2013). A focus on the end-user was often missing, because of the current top-down approach in smart grids development. However, active involvement of end-users in smart grids, including acceptance and adoption of smart grid products and services will be required to support the functioning of technical systems that balance energy demand and supply (ETPS, 2011; Top team Energy in Netherlands, 2012; IEA, 2011; Reinders et al., 2012; Geelen et al., 2013).

In order to facilitate the acceptance of new energy products and services in smart grids, a better understanding of people's participation, experiences, and expectations will be required. Currently, limited knowledge exists regarding to what extent smart grids deployment has facilitated a more active participation of end-users (Geelen, 2014). To support the development of new innovative smart grid products that support end-users in energy management in a smart grid, it is necessary to explore the implementation of residential smart grid pilot projects, participation of end-users in these projects, and user experiences and interaction with the products and services introduced in these projects. Also, little is known about the functioning and effects of these products and services on energy performance of households. This is because smart grid technologies have become available only since recently.

1.7 Research objective

The objective of this research is to develop new insights for the development of residential smart grid projects, and the design of smart grid related products and services that could facilitate a better participation of end-users in energy management at the residential areas.

1.8 Research questions

1.8.1 Main research question

The main question this research aims to answer is:

What design-related insights should be taken into account in the design and development of future residential smart grid projects, products and services in order to facilitate a more active participation of end-users in a smart grid?

1.8.2 Sub-research questions

In order to answer the main research question, the following sub-questions will be explored:

- 1) What is the existing knowledge from literature on end-users of smart grids, current smart grid products and services for households and stakeholder involvement in smart grids?
- 2) How do smart grid stakeholders assess the development and performance of residential smart grid projects, and the products and services that are part of the projects?
- 3) What insights can be gained from evaluating current residential smart grid projects from a user perspective, in particular with regards to the energy performance of products and services implemented in these projects?
- 4) How can design interventions support the development of new products in future smart grid households?
- 5) Which functionalities do end-users prefer with regards to new products and services for smart grid households?

1.9 Outline of the thesis and research methods

As a result of the multi-disciplinary nature of this research, different research methods are

employed. These methods are differentiated per chapter based on the proposed research questions.

In general, qualitative and quantitative approaches were employed in this research. The choice of a mixed-methods approach is a result of the newness of the topic of smart grids, and the strength of a mixed-methods approach in minimizing the limitations of both quantitative and qualitative approaches.

The research presented in this study is executed in the context of Industrial Design Engineering (IDE). The discipline of IDE plays a key role in product development. The “innovation flower of industrial product design” shows that a combination of technology, societal, user, marketing, human, and design and styling factors are important for a successful and innovative product design (see Figure 1.7). This research contributes towards the development of the field of IDE by investigating smart grid products and services for households, thereby providing knowledge and insights that was previously not available.

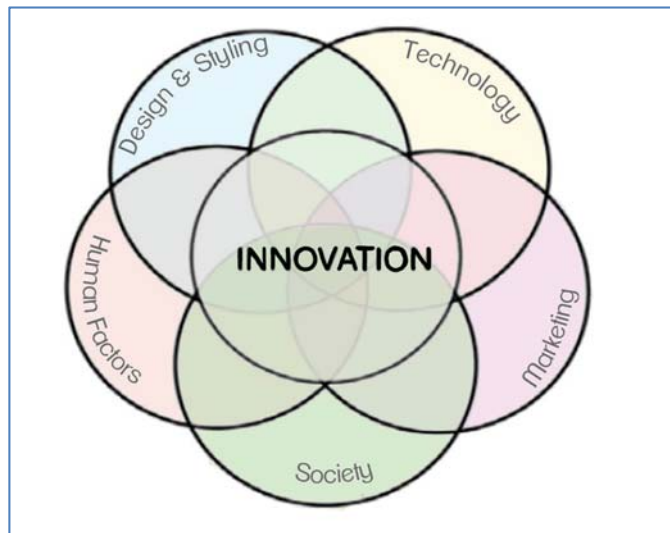

Figure 1.7. Scheme of parameters represents the design process
Source: Reinders et al., 2012

The conclusions of this dissertation will combine two areas namely: technical and user research, which are relevant for the topic of smart grids and development of smart grids related products and services.

A design-driven approach was employed in this study. A design-driven approach aims to combine ‘top-down’ implementation from a technical and economic perspective with end users’ needs, perceptions and capabilities, or what is referred to as ‘bottom-up’ requirements.

This thesis is divided into six chapters. The following section briefly describes the context of each chapter and the applied research methods. A graphic overview of the thesis is given in Figure 8.

In **Chapter 2**, a literature study on end-users and stakeholder involvement in residential

smart grids is described, thereby answering sub-question 1.

Chapter 3 explores the views and perception of broad range of smart grid stakeholders on the set-up and implementation of smart grid projects, the involvement of end-users and the development and performance of the products and services offered. It presents the results of semi-structured interviews conducted with stakeholders involved in the set-up and implementation of five different Dutch residential smart grid pilot projects such as electricity grid operators, smart grid project developers, end-users and local energy cooperatives. Sub-research question 3 is answered in this chapter.

Chapter 4 assesses and compares end-user involvement and experiences with smart grid products and services offered in two different smart grid projects, and the energy performance of households participating in these projects. The projects evaluated are the PowerMatching City smart grid pilot project in Groningen, and the Pecan Street smart grid in Austin, Texas USA. The study was based on a quantitative analysis of energy usage data and questionnaire surveys of user experiences in both projects. This chapter answers sub-question 4.

Chapter 5 evaluates how Industrial Design Methods (IDMs) could support the development of new innovative smart grid products known as Home Energy Products (HEMPS). It also presents end-user perceptions and preferences regarding the attributes of both existing and conceptual HEMPS that support end-users in energy management in a smart grid. Sub-research questions 4 and 5 are answered in this chapter.

Chapter 6 is the final chapter of thesis and presents the conclusions, discussion and recommendations. In this chapter, the knowledge and insights gained from the previous chapters are used to offer useful recommendations for future residential smart grids deployment, and most specifically, future products and services development. This chapter brings the findings of each study together in a general conclusion. Furthermore, the limitations of the research, contributions to knowledge and practice and recommendations for future research are discussed.

An outline of the thesis is presented in Figure 1.8.

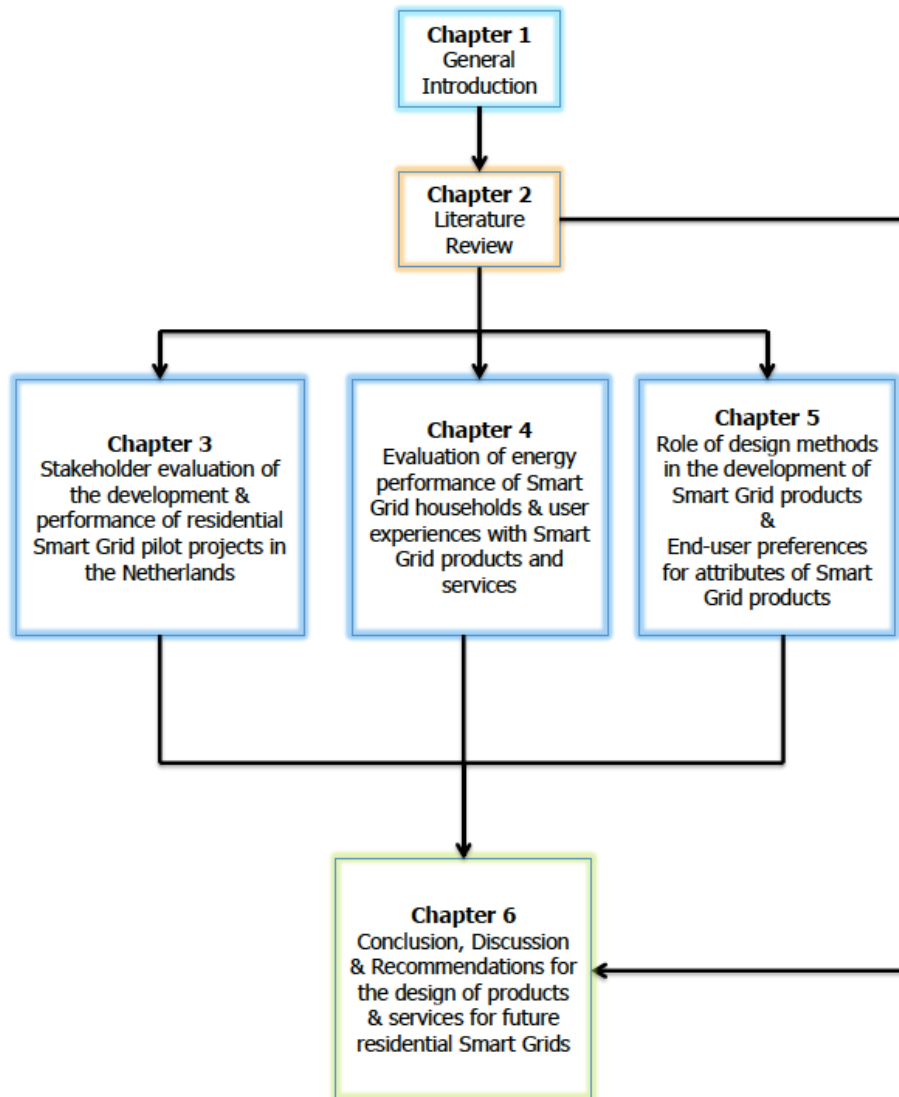

Figure 1.8. Overview of thesis

Chapter 2 Literature study on end-users and stakeholder involvement in residential smart grids

This Chapter contributed to the literature study of the ERA-Net Smart Grids Plus project Co-evolution of Smart Energy products and services 'CESEPS': Markočič, E., Hassewend, B., Obinna, U., Respinis, M. de, Reinders, A., Schram, W., Sark, W. van, Gultekin, E., Mierlo, B. van, Robledo, C., Wijk, A. van, Uebermasser, S. and Lehfuss, F., Literature Study on Existing Smart Grids Experiences, Report, CESEPS project, 2017.

2.1 Introduction

What knowledge currently exists regarding how end-users and stakeholders are currently involved in smart grid projects? What are the current experiences with existing smart grid products and services in residential smart grids?. Answers to these questions could support the successful deployment of future residential smart grids at the low voltage level.

This Chapter specifically focuses on the participation of end-users in smart grids deployment, namely to what extent the wishes and input of end-users are taken into account in current smart grid initiatives, and how current smart grid products and services have supported an active role for end-users in residential smart grid projects.

This chapter is structured as follows: in Section 2.2, the method used in identifying the studies that formed the basis of this literature exploration is presented. Section 2.3 discusses end-user engagement in smart grids. Next in Section 2.4 end-users as co-providers are discussed. Section 2.5 explores the importance of designing for end-user engagement. In Section 2.6, current smart grids products and services for households are presented. Section 2.7 explores end-user interactions with smart grid products and services. Finally, in Section 2.8, based on the evaluation of existing literature an overall conclusion and reflection is drawn regarding the opportunities to foster a co-provider role for end-users in the development of smart grids.

2.2 Research method

Scopus was used as a search medium, since it is considered to have the largest abstract and citation database of peer-reviewed literature in the fields of science, technology, medicine, social sciences, and arts and humanities (Elsevier, 2017).

This literature search was restricted to the following document types: conference papers, articles, conference reviews, reviews, articles in press. Book chapters, editorials, books, short surveys and notes were not included in the literature search. The document types selected are those written in English and published between 2008 and 2017 in Scopus.

The search was limited to keywords, titles and abstracts, in order to collect specific articles related to end-users and stakeholders' involvement in smart grids. The articles for the literature reviewed in this study were explored in three different searches. The first search involved a combined use of the keywords, "Smart Grids" and "Consumers". In the second search, a combination of the keywords "Smart Grids" and "End-users" were used. The third search used the keywords "Smart Grids" and "Stakeholders".

Exclusion and inclusion criteria were applied to limit the literature search to documents most related to the focus of the literature review presented in this chapter. In all searches, the exclusion criteria were articles related to pure and physical sciences, such as mathematics, physics and astronomy, chemistry, biochemistry, genetics and molecular biology, earth and planetary sciences, medicine, neuroscience, agriculture, immunology, pharmacology and chemical engineering and materials science.

The inclusion criteria covered all articles related to engineering, computer science, energy, social sciences, environmental science, business, management and accounting; decision sciences; economics, econometrics and finance; arts and humanities; multidisciplinary, and psychology.

2.2.1 Results

2.2.1.1 Results consumers

The results presented in this Section were based on a combination of the search terms "Smart Grids" and "Consumers".

Using a general search, it was found that between 2008 and 2017, 2351 documents associated with "Smart Grids" and "Consumers" were published at Scopus. After excluding the irrelevant articles based on exclusion criteria stated above, the number of documents was limited to 2090 documents.

The titles and abstracts of these documents were carefully analyzed in order to find documents that focused specifically on consumer involvement in smart grid projects. Therefore, articles that were mainly focusing on the technical aspects of smart grids development, such as demand side optimization, residential load monitoring and peak demand reduction for residential consumers, distribution network optimization, deployment of smart meters and Advance metering information (AMI), flexibility management in low voltage distribution networks, improving energy efficiency of distributed systems, automation in power distribution networks, and demand management in the distribution Grid were excluded. Finally, only seven documents focusing on consumer involvement were selected. The documents included the following journal papers: Wolsink, 2012; Ngar-yin Mah 2012; Gangale et al., 2013; Goulden et al, 2014; Geelen et al., 2013; Toft et al., 2014; and Park, 2014.

2.2.1.2 Results end-users

The results presented in this section were obtained with the use of the search terms "Smart Grids" and "End-users". This search yielded 497 documents. Application of the exclusion and inclusion criteria resulted in 442 document results. Similar to the first search exercise, the titles and abstracts of these documents were carefully analyzed to find documents that focused specifically on end-user involvement in smart grid projects.

As in the first exercise, the results indicate that most of the articles identified were characterized by a focus on user involvement to support technological developments in smart grids. Specifically, the aim was on the exploration of end-users' perceptions towards smart grids and smart grid technologies, stimulating consumer participation in demand side management and their willingness to adopt smart grid technologies. There articles focused on privacy issues and consumer segmentation in smart grids implementation, fostering residential demand response through dynamic pricing schemes, optimizing and monitoring consumer energy consumption.

While the target is end-user involvement, this type of involvement is mainly related to utilizing end-user input to balance electricity demand and supply in the grid. After review of their abstracts, 6 documents relevant to the aim of this review were identified namely: Honebein et al., 2011; Verbong et al., 2012; Gangale et al., 2013; Geelen et al., 2013; van Dam et al., 2012; and Kobus et al. 2013. However, the articles of Verbong, Gangale, and Geelen were already identified in the first search activity in section 2.2.1.1.

2.2.1.3 Results stakeholders

The third search activity, in which the keywords “Smart Grids” and “Stakeholders” were used, resulted in 337 articles. Application of the exclusion and inclusion criteria resulted in 315 documents. A scan of the entire abstract revealed that almost all the documents focused on the optimization of the functioning of the high and medium voltage electricity Grids. In this regard, the involvement of different stakeholders in order to provide more flexibility in the functioning of the electricity grid appeared to be the main focus of these studies. Only 3 studies focused on the involvement of end-users in smart grids at the low voltage areas. These articles include Ngar-yin Mah, 2012, Verbong et al. 2012 and Wolsink, 2012. These studies were also obtained in the first literature search.

From the three search activities conducted, a total of 8 relevant articles were identified namely: Wolsink, 2012; Ngar-yin Mah 2012; Gangale et al., 2013; Geelen et al., 2013; Verbong et al., 2012; Honebein et al., 2011; van Dam et al., 2012; Kobus et al. (2013);

Considering the limited number of articles identified through Scopus search, more articles for this review were identified via the “Snowballing” method. This method implied the use of references of the studies obtained via the search in Scopus to find other relevant articles, especially those studies that were frequently referenced. This additional activity resulted in 2 relevant articles that were included in the review presented in this chapter namely: Van vliet et al., 2005; and Goulden et al., 2014.

In addition, reports focusing on smart grids were included. These include the International Energy Agency (IEA, 2012) technology roadmap smart grids, and the European Commission smart grids technology platform (2010, 2011).

In total, combining the search on Scopus and the “Snowballing” method, 10 articles that formed the basis of the review presented in this chapter were identified (Table 2.1).

Table 2.1. List of articles used in the literature review

Authors	Title	Journal
1.) Geelen et al. 2013	Empowering the end-user in smart grids: Recommendations for the design of products and services	Energy Policy
2.) Honebein et al., 2011	Building a social roadmap for the smart grid	Electricity Journal
3.) Ngar-yin Mah et al.	Consumer perceptions of smart grid	Energy policy

2012	development: Results of a Hong Kong survey and policy implications.	
4.) Kobus et al. 2012	Washing When the Sun Is Shining: How Users Interact with a Household Energy Management System	Ergonomics
5.) Van Dam et al., 2012	Insights into the design, use and implementation of home energy management system	Design research
6.) Gangale et al. 2013	Consumer engagement: An insight from smart grid projects in Europe	Energy policy
7.) Goulden et al. 2014	Smart grids, smart users? The role of the user in demand side management	Energy Research and social science
8.) Wolsink 2012	The research agenda on social acceptance of distributed generation in smart grids: Renewable as common pool resources	Renewable and Sustainable Energy Reviews
9.) Van Vliet et al. 2005	Infrastructures of Consumption: Environmental Innovation In The Utility Industries	Earthscan
10.) Verbong et al. 2012	Smart Grids or Smart Users? Involving Users in Developing a Low Carbon Electricity Economy	Energy policy

The literature search shows that very limited articles that focus on end-user and stakeholder involvement currently exist.

The following section synthesizes the literature and its relationship with the current investigation.

2.3 End-user engagement in smart grids

The transition to smart grids is expected to create electricity systems that enable end-users to make informed and empowered energy-related choices and personal behavioral changes (ECME Consortium, 2010; DeWaters and Powers, 2011). In this regard, evaluative studies and reports (such as IEA, 2011; ETP 2010; EC, 2010) have highlighted the relevance of end-users in smart grids deployment. According to the International Energy Agency (2011) technology roadmap smart grids, end-users of the smart grid must be involved on all aspects of relevance before and during the deployment. The roadmap further states that end-users' feedback and requests for adjustments after deployment and during the actual use and operation of smart grids should be allowed (IEA, 2011). The report mentions that so far, end-users have not been adequately involved during the smart grid

planning process (IEA, 2011). The European Technology Platform (2010) mentions that since end-users (at the residential, service and industrial level) will ultimately determine the success of an energy system based on smart grids, it is vital to promote active user participation in smart grids (ETP, 2010, 2011). The European Commission task force for smart grids also acknowledges engagement and involvement of end-users in smart grids. The task force states that the engagement and education of end-users is an important task in the process of smart grids deployment, given the fundamental changes in the energy retail market. The report further states that the nature of customers' energy consumption will involve significant changes in order to deliver the wider goals of energy efficiency and security of supply (EC, 2010).

In addition to evaluative studies by government and autonomous organizations involved in the energy transition, various studies from literature on smart grids recognize the relevance of end-user involvement in smart grids deployment (e.g. Honebein et al., 2011; Verbong et al., 2012; Gangale et al., 2013; Ngar-yin Mah et al., 2012; Geelen et al., 2013a; IEA, 2012; Gangale et al., 2013). These studies re-affirm the important role that end-users at the low voltage household and residential areas are expected to play in the deployment of smart grids and its associated technologies.

For instance, Honebein et al. (2011) mentions that the success of smart grid initiatives depends on customer action, and suggest that observing, understanding, and engaging consumers at the early stages of development of smart grid initiatives will support the realization of the full potential of smart grids. In this view, they propose a social roadmap for smart grids, in order complement the predominant technical roadmaps from the utility industry. This, in their opinion, will provide a better understanding of end-user experiences, transform end-user relationships, and drive end-user engagement. This study concludes that social acceptance of smart grid technologies could be improved when technological developments go hand in hand with development of a social context for smart grids.

Similarly, a study by Verbong et al. (2012) recognizes the importance of active participation of residential end-users towards the successful implementation of smart grids. Verbong et al. analyzed practices and perceptions of stakeholders on including users in smart grids experiments in the Netherlands. In their study, interviews were conducted with stakeholders related to smart grids and the energy sector. The study concludes that the success of smart grids is dependent on the extent to which users are willing and able to accept and use these smart grids. However, Verbong and colleagues have revealed that the focus in smart grids deployment is still on technological issues and using economic incentives to influence end-user energy behaviour. This is because end-users are often considered a barrier to smart grids deployment; hence, the use of economic incentives seems to be the best instrument to solicit their participation in smart grids (Verbong et al., 2012). The study further concludes that the current neglect of the role of end-users could be a potential obstacle to the introduction of smart grids. In their opinion, there is currently no clear proposal on how to really involve end-users, and support them as co-providers in the future electricity system. They suggest that new innovative business models could be developed to explore different options to involve users. This, they state, will support end-users in embedding new smart grid technologies and options into their daily practices.

Recognizing the need for a better involvement of end-users in smart grids deployment, Ngar-yin Mah et al. (2012) carried out a survey of end-users in Hong Kong to explore

perceptions and acceptance of smart grid technologies. The study asserts that end-user perceptions are one of the main factors for a successful smart grid in which the end-users are entirely motivated and involved. It concludes that it is important to explore how the potential contributions of consumers in smart grid technologies can be realized in order to contribute to the transition towards a more sustainable energy future.

Gangale et al. (2013) therefore proposed to observe end-users in their social context (e.g. household or community) in order to understand and involve them in the early stages of smart grids deployment. They assert that this type of involvement will support them to successfully assume their new role as active participants in the electricity system. Additionally, it will support electricity demand and supply balancing in the power system.

Based on the recognition of the importance of an active involvement of end-users in smart grids deployment, an increase in the interest in consumer engagement projects at European level and a strong focus on the residential sector has been witnessed in recent years (Gangale et al., 2013). Out of the total 459 (R&D and Demonstration & Deployment) smart grid projects, more than 145 projects have the smart customer as one of the main project application (JRC EC, 2013). Figure 2.1 shows that the number of projects focusing on the smart customer has increased since 2005.

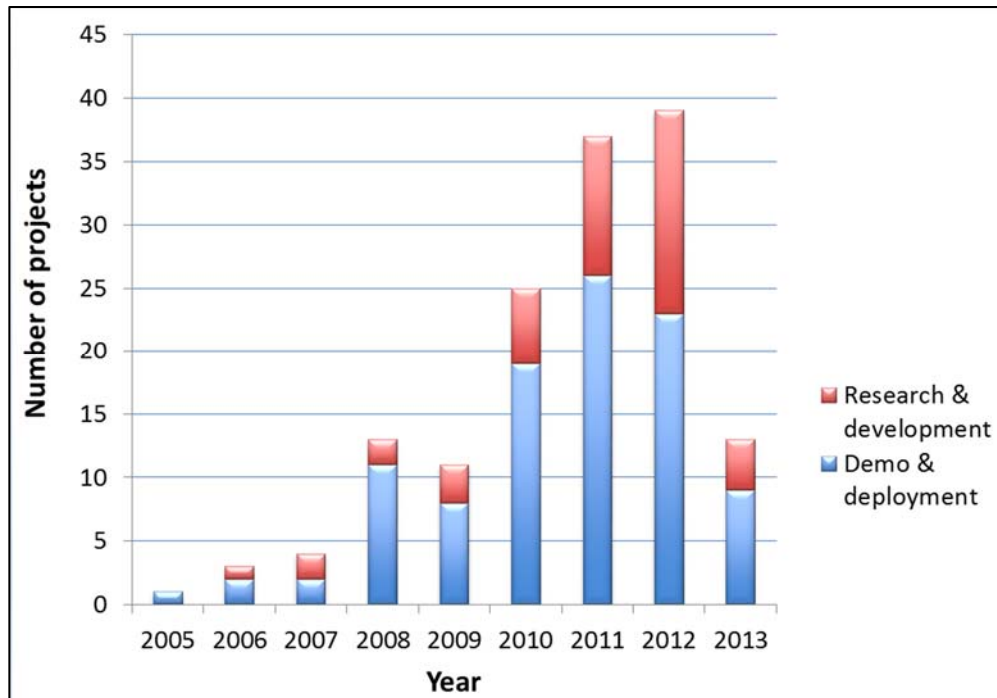

Figure 2.1. Number of projects with a focus on user engagement
Source: JRC EC, 2014

In a survey of consumers' engagement experiences in European smart grid projects, Gangale and colleagues (2013) have revealed that projects involving end-users focus on two main objectives: 1) acquiring deeper knowledge of consumer behavior, and 2) motivating and empowering consumers to become active energy customers. The first objective involves observing and understanding the consumer via the collection of information on consumption patterns, needs and consumer experience; exploring consumer response to new regulatory, technical and market solutions; and identifying consumer segments and early adopters. The second objective is about engaging the consumer by providing them with information about newly introduced smart technologies and applications; their energy consumption; and investigating strategies aimed at behavioral change. However, the type of consumer engagement mentioned above appears to focus mainly on acceptance and adaptation of smart grid technologies by end-users. This approach portrays end-users mainly as passive participants in a smart grid.

As a result of the need to enable and empower end-users in smart grids established in this section, the following section will discuss findings from literature related to fostering a more active role for end-users in smart grids.

2.4 End-users as co-providers in smart grids

As discussed in the previous section, several authors have emphasized the need to involve end-users in smart grids, not just as energy consumers, but also rather as energy citizens or co-providers.

In line with this, Goulden et al. (2014) explored the role of end-users in electricity demand side management, and the contexts in which such roles might emerge. The study used focus groups to probe people's understandings of, and engagement with, their own energy consumption, as well as to explore interactions with current and future smart grid technologies. Two different visions of smart grids are provided namely: a centralized system based on current institutional arrangements, and an alternative system based on decentralized generation and control. The study employs the concepts of 'energy consumer' and 'energy citizen', to depict two forms of public participation in the smart grids. While the 'energy consumer' refers to energy end-users – those that play a more passive role and have limited control and engagement in energy management, the energy citizen refers to those that play a more active role in energy consumption and generation.

Goulden et al. conclude that the energy citizen would be a better approach to ensure user engagement and a broad uptake of smart grid technologies, and a realization of the full potentials of smart grids. This is because the challenge of realizing the smart grid involves both institutional and technical aspects.

They state that the most effective smart grid will be one in which intelligence is sourced from users as well as devices. Therefore, they propose that smart grid designs go a step further than technology, and recognize that a smart user who is actively engaged with energy is important for electricity demand-side management. This, in their opinion, will require a shift from centralized, hierarchical paradigm which has defined the energy

systems of the last century, where centralized generators increasingly monitor and control end-user consumption.

Goulden and colleagues propose the alignment of 'energy citizens' with 'DisGenMiGrids', a concept proposed by Wolsink (2012). 'DisGenMiGrids' or distributed generation micro-grids are intended to replace the current 'Centralized Demand Side Management' of electricity or CDSM. The shift from CDSM to 'DisGenMiGrids' may help to make the distinction between generators and end-users less visible, by replacing it with a kind of 'co-management' of resources. This shift, in their opinion, hold out much greater potential to support end-users in exercising more control over their energy generation and use. The above proposal by Goulden et al. is similar to the type of energy system users defined by van Vliet et al. (2005). Van Vliet and colleagues defined 'co-management' of resources by the kind of relationship between providers and consumers. Van Vliet et al. (2005) uses the term "co-provider" to refer to a trend in which communities collaborate with utilities to achieve solutions in managing water, waste and electricity. The term implies a more active contribution by end-users, in contrast to being only consumers of resources (passive consumers to active contributors). The study reveals that the restructuring of infrastructures stimulates utilities to cooperate with end-users to develop environmentally sustainable systems. Van Vliet identifies three types: (i) customer; (ii) citizen-consumer; and (iii) co-provider. The citizen-consumer and co-provider as used by van Vliet is similar to the energy citizen referred to by Goulden et al.

In the context of smart grids at the low voltage areas, Geelen et al. (2013a) uses the terms "co-provision" and "co-provider" to refer to residential end-users' role in contributing to demand and supply balancing of electricity in smart grids. Geelen and colleagues state that a transition to smart grids will allow end-users at the residential areas to play an active role in energy provision. These end-users will shift from ordinary consumers who buy energy from an energy supplier, to producers of energy, thereby actively taking part in the energy market. They can also contribute to demand response (DR), which is considered a resource in the management of supply and demand (see e.g. Giordano et al., 2011, International Energy Agency, 2011). For this reason, energy stakeholders from the government and private sector try to involve residential end users in the supply and demand management of electricity in a smart grid.

Their study further adds that the transition to smart grids, whereby end users shift to the role of co-providers, household energy management will involve:

- 1) Efficient use of electricity
- 2) Planning and or shifting electricity consumption to moments most suitable for the energy system, for example during the availability of locally generated energy or at periods of low electricity demand
- 3) Producing electricity when it is favorable for the local grid, for example using a micro-cogeneration unit
- 4) Trading self-generated electricity that is not used by households

Geelen et al. suggest that for end-users to become co-providers, end-users will have to be empowered in relation to the four aspects of co-provision mentioned above. An important aspect of this empowerment is a change in energy-related behavior.

The following section will explore current products and services in smart grids, and highlight to what extent these products and services have supported a co-provision role for end-users in smart grids.

2.5 Current smart grids products and services for households

Smart grids enable the development of new products and services that support end-users at the household and residential areas in energy management. These smart grids related products and services would have to support end-users in their role as co-providers in the management of the electric power system (Geelen, 2014).

As described in Chapter 1.4, a study by Geelen et al. (2013a) classified current products and services for the residential end-users as (see Table 1.1): microgenerators, smart meters, smart appliances, energy storage systems, dynamic pricing and contracting, and energy monitoring and control systems.

These categories of products and services (Geelen, et al., 2013) will be briefly described in the following section.

1. Micro-generation: Micro-generation technologies support households to produce and store their own electricity and/ or heat. Examples are photovoltaic solar panels, micro-cogeneration units and small wind turbines.

2. Smart meters: Smart meters refer to digital electricity meters that accurately measure consumption and production of electricity and communicate these data to the energy supplier. They can also be combined with gas, heat and water meters to support energy saving in households.

3. Energy storage systems: Energy storage systems support the use of energy at times other than when they are generated or bought from the grid. The surplus energy can be stored in the form of electrical energy in batteries and as heat in hot water tanks or storage heaters.

4. Dynamic pricing and contracting: Dynamic pricing or dynamic tariff, also known as time-variable pricing, provides an opportunity to involve the end users in the management of the smart grid. For instance, instead of having a fixed electricity price per kWh from the electricity supplier and a fixed yearly network tariff from the network operator, end-users could receive varying costs.

5. Smart appliances: A smart appliance helps a user to select the most desirable time for consuming electricity, for example, by taking into account weather forecasts and electricity prices. Smart appliances can be programmed and communicate with energy management systems regarding the best times to operate. Examples include smart dishwashers and washing machines.

6. Energy monitoring and control systems: This category of products is also referred to

as Home Energy Management Systems (HEMS) or Energy Management Systems (EMSs) (Van Dam, 2010, 2012; Erhardt-Martinez et al. 2010; Geelen et al., 2013a; Kobus et. al., 2013). HEMS can be divided into three groups of products namely: 1) user interfaces, 2) software platforms, and 3) smart hardware (Karlin et al., 2015).

These three groups of HEMS will be further elaborated in Chapter 5. As stated in Chapter 1, we will refer to them as “Home Energy Management Products” (HEMPs), instead of more commonly used terms such as “Smart Grid Products” or “Home Energy Management Systems” that may include a broad range of separate elements that mainly function automatically in the background, with limited or no interaction with end-users.

Recently, various new HEMPs have been developed to support energy management at the household level. According to the Netherlands consumer Association, about 53 HEMPs currently exist in the energy market. Figure 2.2 shows some of the existing HEMPs currently existing in the Dutch energy market. These include smart thermostats, in-home displays and various applications on telephone and tablets that provide insights into energy use, and support the control of certain households’ appliances.

A. Smart thermostats



(a) Toon thermostat



(b) Nest thermostat



(c) Anna thermostat

B. In-home displays



(d) Smappee energy monitor



(e) Anna insight



(f) Maxem energy monitor

C. Smart plugs



(g) Fibaro wall plug



(h) Belkin smart plug



(h) Wemo insight switch

Figure 2.2. Some of the exiting Home Energy Management Products (HEMPs) in the current Dutch energy market
Source: Milieu Centraal (2016)

Although these HEMPs have been developed to support energy management in households, recent studies have shown that these HEMPS have not always supported end-users in achieving this goal (Geelen et al. 2013a, van Dam et al., 2012). The performance of these HEMPS appears to be strongly influenced by the way end-users interact with them.

The following section will discuss current issues regarding end-user interaction with Smart Grid products and services.

2.6 End-users interaction with smart grid products and services

Although smart grids are still in an early stage of development, in recent years, societal implementation has gained momentum through the deployment of smart meters and small and medium scale Smart Grid pilots (Naus et al., 2013; Stephens et al., 2013; Verbong et al., 2013; Wolsink, 2012).

In the opinion of Geelen et al (2013), the success of consumer-driven smart Grid solutions, including new products and services will also depend on consumer value and adoption. They assert that in order to facilitate energy efficiency in households, technology and behavior have to complement each other. Along with societal implementation, scientific research on the use and effects of smart energy technologies is rapidly growing (Naus et al., 2015).

As mentioned in the previous section, studies have shown that some of the HEMPs available today do not address the needs and demands of end-consumers (Geelen et al. 2013a, van Dam et al., 2012). In a study of end-user experiences with products and services implemented in the PowerMatching City smart grid pilot project in the Netherlands, Geelen et al. (2013) revealed that the implemented products did not provide the necessary feedback required by end-users to be more active in their energy management (Geelen et al., 2013b). Their study states that end-users lacked a sense of control and energy feedback that could support them in adjusting their energy related behavior. Several end-users reported that they wanted to change their behavior in order to lower their energy consumption or utilize the electricity that is produced in PowerMatching City. However, they felt insufficiently enabled to do so by these products and services. To summarize, the usage of the implemented technologies did not enable households in both pilots to take control of their household electricity management.

Furthermore, Geelen et al. conclude that in order to support end-users as co-providers in the future energy system, end-user behavior should complement the functioning of technologies. Geelen et al. emphasize that product and service design that supports end-users in their role as co-providers in a smart grid is still missing. They suggest a more active involvement of end-users in the development of products and services.

Similarly, Goulden et al. (2014), mentions that some users of In-home displays complained that these displays were not clear in their presentation of information, and relied on poorly understood metrics like kilowatt-hours. The users in this study preferred displays that presented information in very simple terms.

In line with these issues regarding end-user interaction with smart grids products and

services presented above, studies have advocated the importance of approaching end-user engagement in smart grids from a design perspective.

The following section will, therefore, focus on the potential benefits of a design perspective in fostering a more active participation of end-users in a smart grid.

2.7 Designing for end-user engagement

Given the need to stimulate a more active participation of end-users in smart grids, previous studies such as van Dam et al. (2013), and Kobus et al. (2013), and Geelen et al. (2013) have explored end-user engagement in smart grids from a design perspective. This is especially with regards to the design and development of new smart grid products and services. These previous studies expect that this design-driven approach as depicted in Figure 2.3 may help to combine top-down implementation, as currently witnessed in smart grids deployment, with a bottom-up approach (starting with the needs of end-users). It is also their expectation that this bottom-up approach may support a better exploration and incorporation of needs, wishes and demands of end-users and stakeholders, and foster a more active role for end-users in smart grids.

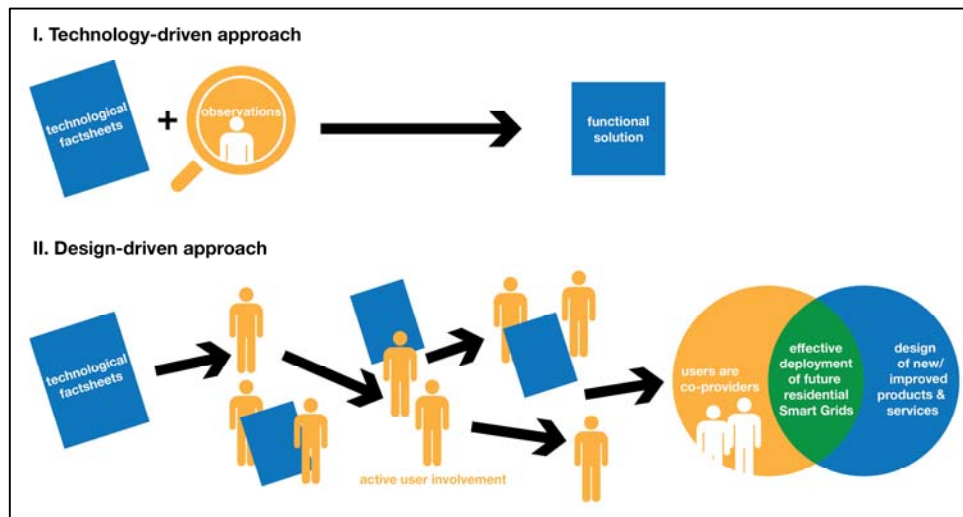

Figure 2.3. Current end-user involvement in Smart Grids and the proposed solution for fostering a co-provider role

Source: Author

In a review of the functioning of energy monitors implemented in a household (Figure 2.4), Van Dam and colleagues (2013) mentioned that using insights from a design-driven approach could enhance the effectiveness of home energy monitors. This, they state, is because a design-driven approach takes the responses of end-users into account in the

development of these energy monitors.



a) Wattcher energy monitor

b) Plugwise energy monitor

Figure 2.4. Energy monitors evaluated by van Dam et al. (2012)

Similarly, Kobus et al. (2012) explored the way users interact with smart energy technologies, and how the design of these technologies influences more desirable habits regarding energy use at home. The study evaluated end-users participating in the 'Your Energy Moment' smart grid pilot project in the Netherlands, where smart washing machines and Energy Management Systems (EMSs) were implemented. Kobus et al. (2013) emphasized the value of a design-driven approach for changing patterns of energy demand at home. They conclude that this approach could support a better design of smart energy technologies, thereby changing energy-use behavior of households. Specifically, their study asserts that easy to use and accessible product and service design is relevant in ensuring that end-users continue using these products and services to sustain energy-efficient behaviour.

Based on a review of literature and related pilot projects described in Section 2.6, Geelen and colleagues (2013) found out that current approaches in smart grids deployment are driven by technical and financial considerations. This approach has led to the design of products and services that fail to support a more active participation of end-users in smart grids. The study concludes that an appropriate approach towards the design of products and services that could support the needed behavioral change of end-users, leading to co-providers in a smart grid is currently lacking. Their study therefore proposes that a design-driven approach will be the key to a more active end-user involvement in smart grids.

In general, both studies conclude that the technical potentials of smart grids implementation should be matched with end-user demands. This is in order to create economic and non-economic value for the end-users, create products and services that will be accepted by end-users, and products that can reach full potential for both end-users and the energy system.

Currently, various innovative smart energy technologies have been introduced both in households and smart grid projects. The aim is to support efficient use and generation, and monitoring of locally generated electricity.

However, there is still limited knowledge with regards to the way households interact with smart energy technologies and how the technologies have influenced the energy performance of these households.

2.8 Conclusions from literature

The literature review revealed that the engagement of end-users is important for the successful development and deployment of smart grids. This has led to an increased attention to investigate and explore smart grids development from a user perspective.

Despite this recognition, there is currently limited information with regards to the end-user and stakeholder involvement in smart grids development at the low voltage household and residential areas.

An important aspect of this involvement is the way end-users interact with the products and services implemented in these projects. Insights from literature show that end-user involvement is still very much limited, with smart grids deployment mainly focused on technological issues and economic incentives. These incentives are meant to facilitate end-user participation in demand and supply balancing of electricity in the power system. With regards to the engagement of end-users in smart grids, the focus has been on the involvement of end-users as energy consumers in the future electricity system. The importance of supporting end-users as co-providers or energy citizens in the electricity system was emphasized in the literature. However, there are limited insights from literature on how this co-provider role has been or could be facilitated in practice. This is because most studies have investigated end-user and stakeholder involvement at the initial stages of smart grids deployment. It is still not clear from the literature on how end-users are currently involved in smart grids, or how they can be supported as co-providers. Only a handful of studies (e.g. Geelen et al., 2013a, Kobus et al., 2012, Van Dam et al. 2012) have explored the role of users as co-providers in smart grids. These studies have, however, so far been limited to individual pilot projects, a small group of residential end-users involved in these pilots, or specific products such as small appliances or energy monitors, or the use of mainly specific exploratory approaches such as interviews or focus groups.

Various products and services that could facilitate a co-provider role for end-users in smart grids have been implemented in smart grid projects. The literature review reveals that current products and services have not always supported an active role for end-users in smart grids. End-users in smart grid projects often have limited interaction with products and services.

Currently, a research gap exists with regards to the active involvement of the end-users, especially in the design process of smart grid products and services.

At the moment, limited knowledge exists regarding to what extent a co-provider role has been facilitated in smart grids deployment. This is especially the case regarding current

smart grids products and services, which are expected to support end-users' co-provider role in smart grids.

Further exploration in field research will employ a design-driven approach to investigate the development and performance of residential smart grid projects, including products and services implemented in these projects. This approach will support a better evaluation of residential smart grids and products and services from end-users and multi-stakeholder perspectives, thereby integrating learning from end-users and stakeholders. This approach may also support the creation of more value for end-users in smart grids by aligning the technical potentials of smart grids with behavioral aspects and the social context of the end users, create products and services that will be accepted by end-users, and products that can reach full potential for both end-users and the energy system (Geelen et al., 2013).

Evaluation of smart grids deployment from a design-driven perspective will ensure better involvement of end-users in smart grids, and a better adaptation to smart grid products and services. It could also support the provision of insights and guidelines for the development of new innovative smart grids related products and services.

To summarize, insights from literature reveal the relevance of stakeholders in smart grids development. Therefore, in chapter 3, an exploratory qualitative approach will be employed to explore the views of smart grid stakeholders regarding the development and performance of residential smart grid projects, and the involvement and participation of end-users and other stakeholders.

Chapter 3 Stakeholder views on the development and performance of residential smart grid pilot projects in the Netherlands

This chapter is based on:

Obinna, U., Joore, P., Wauben, L. and Reinders, A. (2016) Insights from Stakeholders of Five Residential Smart Grid Pilot Projects in the Netherlands. Smart Grid and Renewable Energy, 7, 1-15.

3.1 Introduction

The literature review in Chapter 2 showed that there is currently limited end-user involvement in the development of products and services that will stimulate an active participation in smart grids.

As stated in Chapter 1, various smart grid pilot projects in which new products and services such as smart appliances, in-home displays and smart thermostats are currently taking place in residential areas. Also, various stakeholders such as energy suppliers, grid operators, and product residential end-users are involved in the development and implementation of these projects. However, limited insights exist yet from these stakeholders regarding the set-up and implementation of residential smart grid projects, the involvement of end-users in these projects, the performance of these projects, and the functioning of products and services implemented in these projects. In this Chapter, this deficiency in knowledge will be explored in the context of research question 2 (Section 1.8.2).

This chapter is structured as follows: Section 3.2 presents the background and objective of this study. Section 3.3 discusses the theoretical and methodological part of this research, including a brief description of the smart grid projects where the interviewees have been involved in. Next, the outcome of the stakeholder interviews will be presented in Section 3.4, followed by discussion and conclusions in Section 3.5.

3.2 Research background and objective

As described in Chapter 1, the number of smart grid projects is continuously growing. More than half of these projects are taking place at the low voltage residential areas (Netbeheer Nederland, 2016). This focus is partly as a result of increased small-scale distributed energy systems in and around homes and neighbourhoods, which are expected to become a common feature in future electricity systems (Ref). In this regard, end-users are expected to become important actors in sustainable energy management (IEA, 2011; Fang et al., 2012, Nye et al., 2010).

Chapter 1 also showed that smart grids development has resulted in various new energy-related products and services, such as smart meters, smart appliances, micro-generators, storage systems, and energy monitoring and control systems (Geelen et al., 2013a).

However, information about the performance of smart Grid projects, and the development and use of smart energy products and services in smart grid initiatives is lacking. This study aims at collecting more information from the field regarding the development and implementation of smart grid pilots and related products and services.

The main research questions of this study are therefore:

- 1) How have some typical residential smart grid pilots in the Netherlands been set up?

- 2) Which stakeholders are involved in these pilots?
- 3) What are their views and perceptions with regards to the development and performance of residential smart grids?
- 4) What do these stakeholders think about products and services that may support an active participation of end-users in a smart energy home?

These questions are explored because smart energy products and services are currently being implemented in residential smart grid projects, with the expectation that it will support households to improve their energy efficiency, contribute to a more sustainable energy production, and take part in the management of the electricity system (Gungor et al., 2011; Geelen et al., 2013a).

With regards to these products and services, evaluative reports on smart grid developments have highlighted the importance of products and services that meet end-users' needs (IEA, 2011; Giordano et al., 2011). These reports highlight that in addition to the development of technological products, emphasis should be placed on how these technologies are adapted and domesticated by end-users.

As stated before, whilst the views and perceptions of end-users participating in smart grid initiatives have been the basis for these insights, there is still limited insights and reflection from other stakeholders (e.g. grid operators, smart grid project developers and managers, local energy cooperatives) involved in the development and implementation of these initiatives. These insights will be significant information because these stakeholders have a major influence on the set-up of new smart grid pilots and the selection of smart energy products used in these pilots. Therefore, insights from stakeholders from residential smart grid initiatives could support future implementation, and could also help to generate ideas for future development of smart grid related products and services that match end-user expectations. It could add to the limited knowledge and experience in practice from smart grid initiatives, which are considered a first step in large-scale implementation of smart grids (Gangale et al., 2013; IEA, 2011).

3.3 Research method

3.3.1 Methodology

This research draws upon the theoretical framework of Strategic Niche management (SNM). SNM posits that successful radical innovations originate from socio-technical experiments in which various stakeholders collaborate and exchange information, knowledge and experience, thus embarking on an interactive learning process that will facilitate the incubation of a new technology. This occurs in a protected space called a "niche", a specific application domain for the new technology.

Strategic Niche Management (SNM) was developed as an analytical approach that can be used to review and analyze the development of innovative technologies in niches, which can be seen as incubation rooms or protective systems surrounding the new technology (Caniëls and Romijn, 2008; Schot and Geels, 2008; Smith and Raven, 2012; Kamp and Forn 2015). SNM assumes that promising new sustainable technologies can be promoted by

actively shaping technological niches, i.e. protected spaces that allow experimentation with the co-evolution of technology, user practices, and regulatory structures (Schot and Geels, 2008; Hoogma et al., 2002).

SNM focuses on processes that are internal to the niche development, and SNM is useful for learning about needs, shortcomings in technology and strategies to overcome these (Hoogma et al., 2002; Van der Laak et al., 2007). During the period of niche development, the emerging technology has to compete with the existing technologies, which are technologically and economically superior to it (Geels and Schot, 2007; Kamp and Forn, 2015). These established technologies are part of large social networks, the regimes, which have certain rules such as price/performance ratio, engineering practices, user preferences and regulatory requirements (Kamp and Forn, 2015).

SNM emphasizes three interconnected processes that are required for the successful development of innovations, namely: 1) articulation of expectations and visions that become more specific and better aligned among the stakeholders, 2) formation of a wide and interconnected social networks, and 3) learning processes (Kemp et al., 1998; Geels and Schot, 2010; Hoogma et al., 2002).

Articulation of expectations and visions relate to how niches are presented to the public and whether they live up to the promises they make about performance and effectiveness. Expectations provide direction to the technology development, influence design choices, attract resources and new stakeholders, and ensure that outsiders are not left out in the transition experiment (Hoogma et al., 2002). In this stage, firms, users, policymakers, entrepreneurs and other relevant actors participate in projects on the basis of expectations. Articulating and negotiating expectations is important to attract attention and resources, as well as to involve new actors the network, especially when the technology is still in early development and functionality and performance remain unclear. Expectations also provide direction to development: they act as cognitive frames for making choices in the design process. Hence, a process of articulating and negotiating expectations guides the direction of innovation.

Formation of social networks focuses on the composition of the network and alignment of the actors within it in order to evaluate their influence on the development of the niche (Raven, 2005). Experimentation in niche markets can bring new actors together and allow the formation of new social networks. This process is considered successful when the network is broad, including complementary technologies and infrastructure, and a wide range of representative actors or potential adopters (Kemp et al., 2001; Elzen et al., 2004). SNM scholars also promote broad and heterogeneous networks comprising of both technology actors, such as firms and technological research organizations, and actors representing social concerns such as policy actors, users, and non-governmental organizations such as representatives of the environmental movement.

Learning processes is considered an important issue with regards to the introduction of new technologies. Learning from stakeholders in practice facilitates adjustments in technology and social embedding to increase chances on successful diffusion (Hoogma et al., 2002). Hoogma et al. propose a broad concept of learning that involves learning about the technologies, but also learning about users, societal and environmental impacts and government policy. SNM authors advocate that the role of users should be far greater than sources of market information (Weber et al., 1999, p. 68; Hoogma and Schot,

2001). Involving users in experimentation is also considered a key mechanism for stimulating deep learning Hommels et al. (2007). Learning processes comprises of 'first-order' and 'second-order' learning. 'First-order' learning involves lessons about projects and experiences and improving performance. First-order learning means that, in a niche, actors learn about how to improve the design of a technological innovation, which features of its design are acceptable for users and ways of creating a set of policy incentives that will facilitate its adoption. Second-order learning emphasizes that learning for innovations should extend from technology development to testing actual changes in user practices (Coenen et al., 2010; Hoogma et al., 2002). Second-order learning is required for the establishment of a regime shift on the basis of niche development. In second-order learning, conceptions about technology, users, demands and regulations are not tested, but questioned and explored. This is called "co-evolutionary learning" (Hoogma et al., 2002: 29). Successful niche development consists of first-order learning on a wide range of aspects linked to second-order learning. A good learning process is widely recognized as crucial for successful innovation (Kamp and Forn, 2015).

Smart grid projects, which aim to facilitate sustainable transition to a low carbon electricity regime, qualify as a "niche", and hence can be analyzed using SNM (Verbong et al., 2012). Local experiments such as Smart Grid projects have an important role in SNM for sustainable technology development. A core assumption of the SNM approach is that promising new sustainable technologies can be promoted by actively shaping technological niches, i.e. protected spaces that allow experimentation with the co-evolution of technology, user practices, and regulatory structures (Schot and Geels, 2008). With regards to smart grids development, the first process in the SNM framework, articulation of expectations and visions has been applied to analyze practices and perceptions of smart grid stakeholders on including users in smart grids experiments in the Netherlands (Verbong et al., 2012). Verbong et al. employed the articulation of visions to ask stakeholders involved in smart grid development their visions on smart grids. Building on the study of Verbong, we went a step beyond articulation of expectations to explore both learning processes regarding smart grid products and services currently implemented, and user interaction with these products and services. This is because end-users are already involved in various smart grid initiatives that are either still ongoing, or already completed. What is currently missing is knowledge about actual user practices and experiences related to their participation in smart grids. Therefore, in this study, we will explore and evaluate building of social networks and learning processes in residential smart grids. This chapter contributes to literature by using the SNM approach to explore the views of the most important stakeholders in residential smart grids.

3.3.2 Study design

The Netherlands was chosen as a location for this research since it provides a growing number of smart grid pilot and demonstration projects.

This study used a qualitative approach and is explorative in nature. It is based on semi-structured face-to-face interviews with nine stakeholders involved in the set-up and implementation of five different Dutch residential smart grid pilot projects (see Table 3.1). The semi-structured interviews were used because smart grids are still in the early developmental stages, hence the need to get more insights from stakeholders involved in the development. The open and informal style of semi-structured interviews supported the respondents to express their views and opinions in their own terms, while also having the flexibility to provide more details when required. It also allowed the drafting of topics that served as a guideline in exploring the views of the stakeholders.

From the about 30 smart grid pilot projects taking place in the Netherlands in 2014 (Netbeheer Nederland, 2014), we selected those pilot projects that incorporate social (user aspects) in their implementation, and have implemented almost the same kind of products and services. Another important consideration in selecting these pilot projects was the ease of getting access to the stakeholders, and the willingness of the stakeholders to participate in the interviews.

Table 3.1. List of stakeholders interviewed

Stakeholder	Role of Stakeholder	Project
1.Consultant	Project management/Energy consultancy	PowerMatching City I and II Groningen
2.Project leader	Project management/Energy consultancy	PowerMatching City I and II Groningen
3.Project developer	Project management	PowerMatching City I and II Groningen
4.Participant	End-user	PowerMatching City I and II Groningen
5.Researcher/ developer	Grid operator	Your Energy Moment Breda and Zwolle
6.Technical project leader	Project management	Returns for Everybody Amersfoort and Utrecht
7.Project coordinator	Local energy cooperative	Cloud Power Texel
8.Project leader	Local energy cooperative	Smart grids Lochem
9.Project manager	Grid operator	Smart grids Lochem

The stakeholder selection process started with the consultation of known experts in the field of smart grids. Further stakeholders were found using 'snow-balling' as a method. This resulted in about twenty (20) stakeholders from eight smart grid projects in the Netherlands, who were subsequently contacted by phone to take part in the interviews. In the end, nine stakeholders, from five different projects agreed to take part in the interviews. The stakeholders interviewed in this study (n=9) can be considered to be statistically low. This is due to the fact that there are currently not a lot of people working in the area of smart grids development at the residential areas. Also, smart grids are not

commercially installed or implemented yet. Therefore, we consider the sample size, which represents about 50 percent of the smart grid Stakeholders, as being quite representative. Emails were thereafter sent to the respondents to provide more details about the objectives of the study and to schedule appointments for the interviews. The interviews were subsequently conducted individually with the stakeholders, at the locations of the pilot projects and consisted mainly of open-ended questions. The interviews took place between May and September 2014, and lasted between 1 and 1.5 hours.

The five smart grid pilot projects selected included:

- 1) The "PowerMatching City" project (phases I and II) in Groningen
- 2) "Your Energy Moment" projects in Breda and Zwolle
- 3) "Cloud Power Texel" project in Texel
- 4) "Returns for Everybody" projects in Amersfoort and Utrecht
- 5) "Smart Grids Lochem" project in Lochem

The research in each of the pilot projects is different in terms of the technologies, involvement of end-users and research questions and approaches. However, the aim of this study is however not to compare these projects, but to gather insights from a broader range of stakeholders involved in the development and implementation of residential smart grid initiatives.

The selected smart grid pilot projects are described in more details below. Table 3.2 provides a summary of the selected projects and Figure 3.1 shows the locations of the various projects in the Netherlands.

3.3.2.1 PowerMatching City I and II in Groningen

This smart grid pilot project is one of the first projects where smart energy technologies were implemented in homes connected through a smart grid (Bliek et al., 2010; Geelen et al., 2013b). DNV GL (a Dutch Energy Consultancy company), together with five other project partners (Enexis, Essent, Gas union, ICT automation, TNO research institute) and three knowledge institutes (Hanze polytechnic Groningen, Delft University of Technology, Eindhoven University of Technology), run the project. The project focused on attaining optimum capacity management in a smart grid, and matching energy services with the demands and wishes of end-users (Netherlands Ministry of Economic Affairs, 2013a).

The project was carried out in two phases. Phase one started in 2007 with the realization of a local smart grid with 22 homes. An additional 18 homes were added in 2011 to bring the total number of homes to 40. The homes were equipped with a micro-cogeneration unit, a hybrid heat pump and hot water tanks, smart appliances such as smart dishwashers and washing machines, and in-home displays (Energy monitor). Also, the homes generated energy through solar photovoltaics installed on their roofs and the roof of other partners. An agent-based algorithm called the 'PowerMatcher' manages the energy flows in the local smart grid. This controls the switching on and off of smart appliances, heat pumps, and micro-cogeneration units based on market mechanisms and user settings.

PowerMatching City phase one was finalized in 2011, while phase two finished in 2014. A detailed of PowerMatching City is described by (Bliek et al., 2010).

3.3.2.2 Your Energy Moment in Zwolle and Breda

This smart grid pilot project (Netherlands Ministry of Economic Affairs, 2013b) is run by Enexis (a Dutch major utility company). Other partners in the project include housing corporation SWZ (Samenwerkende Woon- en Zorgvoorzieningen in Dutch), Dong Energy (energy supplier), Consultants to Government and Industry (CGI) Logica (Information and Communication Technology (ICT) company), Flexicontrol (product and service supplier) and a knowledge institute (Eindhoven University of Technology). The Your Energy Moment project focuses on acquiring more experience with technical, economic and social options for creating flexibility and increased sustainability in the energy consumption of consumers, in a realistic and practical environment. The project aims to achieve an active end-user participation in a smart grid system and also change consumer behaviour in order to save energy and reduce peak electricity loads. The participants in the pilot project also receive dynamic prices. The objective is to investigate if households are able and willing to adapt their demand to times on which supply is abundant.

It consists of 250 homes equipped with a smart grid, solar panels, home energy management systems, smart washing machines and dryers. The pilot in Zwolle started in 2012 and consists of 100 homes. The pilot in Breda started in 2013 and consists of 150 homes. Both projects of Your Energy Moment will run till 2015.

3.3.2.3 Returns for Everybody in Amersfoort and Utrecht

This smart grid pilot project, known as 'Rendement Voor Iedereen' in Dutch, is sponsored by the province of Utrecht, and the municipalities of Utrecht and Amersfoort (Utrecht Sustainability Institute, 2014). Other partners involved in this project include Stedin (grid operator), DNV GL, Capgemini (product and service supplier), knowledge institutes (Universities of Groningen and Utrecht, Utrecht polytechnic), Ecofys (renewable energy supplier), Lomboxnet (ICT company), Eemflow (local energy cooperative), Icasus (citizen's initiative), and innovation taskforce Utrecht region (Utrecht Sustainability Institute, 2014). Returns for Everybody develops and tests various new smart grid services related to the future electricity network. It consists of 100 homes in Amersfoort and Utrecht, where eight new smart grid service concepts are being developed and tested. These services focus on energy savings and optimal use of locally produced solar energy. The homes consist of an energy management system, solar photovoltaics, and smart meters. Both pilots of Returns for Everybody were carried out between 2012 and 2014.

Table 3.2. Summary of the smart grid pilot projects included in this study

Project	Technologies used	Number of homes	Timeline	Stakeholders
1) PowerMatching City I and II Groningen	Electric vehicles, hybrid heat pumps, in-home energy displays, powermatcher software, photovoltaic	40	2007-2015	Grid operator, knowledge institutes, energy consulting company, ICT software company, gas company,

	systems, smart meters and appliances (washing machine, freezer, dishwasher), smart thermostats, micro-combined heat and power (CHP) systems, wind turbine, mini gas turbines, electricity storage, automated meter reading			service provider, energy supplier, individual end-users
2,3) Your Energy Moment Zwolle and Breda	Smart grid, photovoltaic systems, smart appliances (washing machines, dryers)	250	2012-2015	Grid operator, knowledge institute, product and service suppliers, housing company, energy supplier, local energy cooperative (end-users)
4,5) Returns for Everybody Amersfoort and Utrecht	Heat pumps, electric vehicles, in-home electricity storage	200	2012-2015	Grid operator, knowledge institutes, product and service suppliers, energy supplier, local energy cooperative (end-users)
6) Cloud Power Texel	Smart meters, cloud power (energy matching software), wind turbines, photovoltaic systems	300	2012-2014	Grid operator, project developer, ICT company, product supplier, sustainable energy supplier, local energy cooperative (end-users)
7) Smart Grids Lochem	Photovoltaic systems, electric vehicles, smart meters	130	2012-2015	Grid operator, knowledge institute, product suppliers, energy supplier, energy supplier, local energy cooperative (end-users)

3.3.2.4 Cloud Power Texel in Texel

Cloud Power Texel is a bottom-up experiment initiated by a community of energy users that individually and collectively try to make their energy use more sustainable and be energy independent with renewable energy sources (Verbong et al., 2012). The project was started by TexelEnergie, a local energy cooperative with more than 3000 members (Netherlands Ministry of Economic Affairs, 2013c). The electricity grid operator Alliander came in afterwards to use it as a try-out for smart meters in houses. A product and service supplier, known as Capgemini, was also involved in the initial stages of the project development.

The Cloud Power Texel smart grid pilot project explores how a community can provide its own energy needs, by stimulating energy efficiency and behavioural change. The project was carried out in Texel (an island in the Netherlands) and included 300 homes (TexelEnergie, 2015). Technologies implemented in this project include smart meters, an in-home energy display called "Kiek" that gives insight in energy use and generation, home energy management systems and distributed generation units connected to the grid. The Cloud Power Texel project was carried out between 2012 and 2014.

3.3.2.5 Smart Grids Lochem in Lochem

Smart grids Lochem is a bottom-up initiative set up by a local energy cooperative, LochemEnergie. Other partners involved in this smart grid pilot project include Locamation and Eaton industries (product and service suppliers), Alliander (grid operator) and University of Twente. This project takes place in an existing residential area, where participants (members of the local energy cooperative) are equipped with a smart meter called "Mpare", solar photovoltaics on their own roofs and roofs of other public buildings (Netherlands Ministry of Economic Affairs, 2013d). Smart grids Lochem explores how to involve and stimulate residential end-users to reduce their energy consumption, make use of renewable energy, and help in aligning energy demand and supply. Also, experimenting with electric vehicle (load technics and behaviour) is part of this project. The smart grids Lochem project started in 2011 and will be completed in 2015.



Figure 3.1. Location of smart grid pilots in the Netherlands

3.4 Interviews

The questions for the interviews were grouped into three main themes. These include:

- 1) Stakeholders' involvement in the project's preparation phase
- 2) Stakeholders' perception of products and services for smart grid pilots
- 3) Requirements for future products and service development

3.4.1 **Theme 1. Stakeholders' involvement in the project's preparation phase:** The questions under this theme mainly focused on identification of stakeholders involved in the development of residential smart grid pilot projects:

- their respective roles in the realization of the projects;
- the estimated costs of setting up the projects and the funding sources;
- the major expenditures involved;
- the stakeholder considered the most important in the realization of residential smart grid projects.

3.4.2 **Theme 2. Stakeholders' perception of products and services for smart grid pilots:** The questions under this theme mainly focused on exploring current products and services offered in the projects, and the perception of smart grid stakeholders on:

- the current approaches used in developing these products and services;
- the performance of smart grid products and services;
- the role of various stakeholders (including end-users) in the development process.

3.4.3 **Theme 3. Requirements for future products and service development:** The questions under this theme mainly focused on exploring stakeholders' views on potential smart grid products and services;

- the functions these products and services are expected to perform;
- current and future demands with regards to product and service development for residential smart grids.

3.5 Data analysis

The data gathered from the interviews was analysed manually. First the interviews were digitally recorded using a voice recorder and were transcribed verbatim as a word document. Then, the main views and perspectives were identified and discussed with the authors. After consensus, these main views and perspectives became the basis for further analysis.

Validation of the information by respondents is an important aspect of ensuring the accuracy of data collected through unstructured interviews (Kumar, 2014). In order to increase completeness and reduce inconsistencies, the results of this study were checked by two of the respondents (a grid operator and a project manager of a local energy cooperative). These respondents provided useful comments to refine the results.

3.6 Results

This study explored the views and perceptions of nine stakeholders involved in residential smart grid pilot projects, with regards to the implementation of these projects and the development and performance of products and services. The following section presents the findings from the interviews. An overview of the findings is presented in Table 3.3.

3.6.1 Theme 1. Stakeholders' involvement in the project's preparation phase

3.6.1.1 Setup project: From the five smart grid pilot projects explored, one project (PowerMatching City) was set-up as a European Union project; one project (Your Energy Moment) was set-up by a grid operator (Enexis); two projects (Cloud Power Texel and Smart Grids Lochem) were set-up by local energy cooperatives (TexelEnergie and LochemEnergie) and a grid operator (Alliander), and one project (Returns for Everybody) was initiated by the provincial and municipal governments. PowerMatching City was carried out mainly with subsidy from the European Union. The other four projects were partly funded by subsidies from the national, provincial and municipal governments and the various partners involved in the projects, like the grid operators (such as Alliander and Enexis), local energy cooperatives (such as LochemEnergie and TexelEnergie) and energy suppliers (such as Essent and Dong Energy).

The major costs in these projects were similar (ranging from 5 to 10 million euros) and were mostly spent on the procurement and installation of equipment such as smart meters and appliances, development of the needed knowledge and infrastructure such as smart charging stations for electric vehicles, services on storage, deployment of software installations, and workshops and information dissemination to encourage end-user participation.

3.6.1.2 Involvement of stakeholders: In general, the following stakeholders were involved in the development and implementation of residential smart grid pilot projects:

- European Union (in one project)
- National, provincial and municipal governments (in two projects)
- Grid operators (in all five projects)
- Energy suppliers (in five projects)
- End-users participating homes (in all five projects)
- Product and service suppliers (in four projects)
- Information and Communication Technology (ICT) companies (in two projects)
- Knowledge institutes (in four projects)
- Local energy cooperatives (in four projects)

The European Union provided the funding for large-scale pilot projects, such as the PowerMatching City project. The national, provincial and municipal governments supported the funding of smaller-scale projects, such as Smart Grids Lochem, Cloud Power Texel, and Returns for Everybody.

In all projects, the grid operators were mainly involved to explore methods to reduce peak load in the electricity grid. They also provided dynamic pricing that helped to influence end-user behaviour in using energy at certain preferred times (such as when there is increased renewable energy generation or during periods of lower peak in the electricity network).

The grid operators Alliander and Enexis were involved in all five projects.

The energy suppliers produced and delivered gas, electricity, heat and energy services to the participating homes in these smart grid pilot projects. Their main purpose of participating was to deliver new types of services, and get the best value out of the demand response that end-users can provide.

End-users (as individual households or local energy cooperatives) mainly have interest in becoming less dependent of the large energy producers, and support the building of a sustainable energy system that they can control. They also supported the provision of flexibility in energy use by adjusting and adapting their energy usage behaviour, in response to the flexible pricing provided by the grid operators.

The ICT companies were responsible for the development of software that enabled all the components of the energy system to communicate in a smart way. The ICT supplier looked at the system integration.

The product and service suppliers were responsible for producing and supplying various hardware and software, such as smart meters, energy usage insights and energy management. The various knowledge institutes supported the development of knowledge and various software needed to match energy supply and demand. Their input also focused on studying behavioural issues concerning residential end-users, and the interaction of end-users with various technologies. The local energy cooperatives served as a platform for end-users to organize themselves in building and managing a sustainable energy system.

The local energy cooperatives were involved in the set-up of four projects (Returns for Everybody, Cloud Power Texel, Smart Grids Lochem and Your Energy Moment), while the grid operators (also known as Distribution System Operators - DSO's) were involved in the set-up of all projects. The product and service suppliers were involved in the set-up of three projects (Smart Grids Lochem, Returns for Everybody and Your Energy Moment).

All respondents considered the DSO's, energy suppliers and end-users (individually or via local energy cooperatives) as the current major stakeholders in residential Smart Grid projects. The results also showed that three projects were initiated through local energy cooperatives, but the DSO's played a leading role in their development and implementation. This was evident by their participation in all projects. According to the coordinator Cloud Power Texel, *"the project in Texel was initiated by TexelEnergie; Alliander came in afterwards to use it as a try-out for smart meters in homes"*. This was also the case with Smart Grids Lochem, where Lochem Energy cooperative initiated the project and asked Alliander and other partners to join. Together they developed a plan and proposal that was submitted to the National government for funding.

Explaining the presence of the grid operators in all the projects, a principal consultant from PowerMatching City said that, *"the grid operators are struggling with the fact that there are quite a number of new technologies that all require additional capacity of the grid, therefore, they are looking for new methods to reduce peak load in the grid and avoid long-term grid costs, hence their active participation in smart grid projects. This way, they will not need to develop the grid anymore like a copper plate with infinite capacity"*

(delivering electricity everywhere at all times)". He also stated that the expected growth in electric vehicles would have an enormous impact on the grid. Therefore, the grid operators are exploring new ways to deliver peak electricity capacity at every point in time in the transition to smart grids.

The interviews revealed that the energy supplier was present in all projects in order to get the best value out of the demand response provided by end-users. Demand response implies alterations in end-users' electricity usage in reaction to supply conditions (IEA, 2011).

However, all respondents acknowledged that the involvement of end-users is an important aspect in smart grids implementation, since they are an essential part of the flexibility required to balance the grid. The project manager of Smart Grids Lochem summed it up by saying that, *"The end-user is the starting point, therefore, it is important to think about what the energy system should be, in order to fulfil the needs of the end-users"*.

3.6.2 Theme 2. Stakeholders' perception of products and services for smart grid pilots

Although the five projects in this study are different in terms of how the smart energy system implemented in the projects look like, the products and services being used are similar for all projects. In all projects, microgenerators, such as solar photovoltaics, were the major renewable energy technologies used. Energy monitoring and control systems, smart meters and supporting devices (e.g. the "Mpare" device used in Smart Grids Lochem), smart appliances and plugs were also deployed in all projects.

In the projects Cloud Power Texel, Your Energy Moment and Returns for Everybody, dynamic pricing featured prominently. This involved the use of varying energy prices to stimulate end-users to shift energy use to off-peak periods to reduce the load on the electricity network.

PowerMatching City and Smart Grids Lochem were the only two projects where energy storage systems were deployed. These were deployed by means of hot water storage, storage heaters and batteries of electric vehicles. This enabled energy use at different times, thereby supporting flexibility in energy use.

With regards to how current products and services are developed, most respondents (8 out of 9) indicated that most of the products and services offered in the pilots, including those that end-users are supposed to interact with, are developed from the perspectives of the technical partners involved in these projects. They stated that current available products and services are still too technical, and this is a problem for the end-users, as they do not always understand how they function. According to the developer from Your Energy Moment, end-users in some of the homes described their in-home display as *"another product developed by techies for techies"* and *"current products are way too technical and complex, not very intuitive and not inspired by end-user insights"*. *It is better to start developing these products with the end-users from the beginning, this will support people to better communicate and interact with the energy system"*.

The consultant from PowerMatching City expressed his opinion as follows: *"These energy products and services are mostly developed from an electrical engineering and digital technology perspective. This is also partly the reason why large-scale roll out of smart*

meters has not been achieved yet. Although the EU wants to achieve large-scale smart meter roll out in 2018, smart meter technology may not be a final solution. The EU has fixed 2018 as the deadline for large-scale roll out of smart meters, this has not been achieved yet due to the fact that the smart meter was developed purely from a technical perspective. A different/new approach will be needed, because the best way of setting up the smart meter has not been defined. While some countries have rapidly rolled out, others are taking it slowly to make sure that they do not invest in the wrong technology”.

He further stated that current products and services are developed from different perspectives, and there is currently a lack of standardized products, and also no interoperability between existing products and services. He went further to state that, *“the interests of people need to be aligned. People do not trust the system because they see devices switch on at moments they do not expect them to. End-users usually look at the technologies differently. They are supposed to use new systems and appliances”.*

The project manager of Smart Grids Lochem stated that the different partners, who want to use the project as a testing ground, independently developed most of the products and services implemented in the pilot project. 4 out of the 9 respondents also stated that these product and service suppliers are usually not partners of the project consortium and are therefore not involved in the day-to-day decision-making processes in the project. Their interaction with the participating end-users was also quite limited.

According to 7 out of 9 respondents, the development process of most of the offered products and services (such as smart meters, in-home displays and digital applications) involved the active participation of end-users and other project partners through various workshops and co-creation activities.

The participating end-user in the PowerMatching City project expressed satisfaction with the smart energy system, since it helped to provide insight in household energy behaviour, and a means to play an active role in their energy usage. He, however, asserted that there is limited interaction between the end-user and the energy system. This, in his opinion, is mainly due to the fact that most of the offered products work in the background. He stated that, *“most of the current products and services work in the background. We want to get more involved with the technology, and have more insights about the workings of technology, and also be aware of what is happening in our homes. It is important to monitor and manually control the smart appliances”.*

He further states that in the smart energy system implemented in the PowerMatching City project, steering of energy usage is still based on centrally determined costs and not on the availability of renewable energy. The PowerMatcher is focused on neighborhood balancing and not on the household level, and schedules the washing machine based on centrally controlled prices, and not always matching the availability of energy generated by solar PV's and wind turbine. This he considers a disadvantage for those end-users that have interest in sustainability rather than cost saving. For instance, they cannot program the washing machine when the solar panels are generating or connecting electric vehicles to solar production.

In his opinion, there is a need for an interface that shows the energy generation on an hourly basis with graphs, the time and costs. He further states that smart washing machine did not always function according to schedule (prediction) and there was no feedback on that from the system. This is not in line with the expectation of the end-users, he states.

Two respondents shared related views with regards to the PowerMatcher software that balances energy demand and supply. In their opinion, products such as the PowerMatcher software that operates in the background needs to be simplified because it is difficult to figure out how it functions and allocates energy to the various in-home appliances.

The project coordinator of Cloud Power Texel said that elements of current products and services need to be improved, because they are way too complex and over-dimensional and not inspired by end-user insights. For this reason, a simplified and improved version of the "Toon" display from the energy company Eneco was developed and implemented in the project. This they called "Kiek", an in-home display that gives insight into energy usage. However, she states that products offered in their project were designed with inputs from all partners in the consortium. They were involved in project development by focus groups, where they make inputs on how the home appliances can be made smarter. For end-users, questionnaires were used to solicit their opinions regarding the functioning of products.

3.6.3 Theme 3. Requirements for future product and service development

The respondents revealed that various products and services would be required to support an active participation of end-users in the future energy system. According to more than half of the respondents (n=5), these include mainly products and services that:

- provide visual insight to end-users with regards to their current state of energy generation, usage patterns of household devices and prices, such as digital applications, graphical user interfaces, games, feedback and energy forecast
- promote dynamic pricing
- support the use of smart appliances (for example, manual programming of washing machine when the sun is shining)
- enable end-users to compare their energy usage with others

According to the project manager of Smart Grids Lochem, most of these products and services could influence end-user behaviour; to use energy more efficiently in households, provide more control over their energy generation and use, and ensure optimal use of renewable energy produced within the community (for example facilitate energy sharing). In the views of the consultant from PowerMatching City, there are currently limited services that support end-users in the usage of various technological products, such as smart meters. Therefore, new user interfaces or remote controls for new services will be needed to support end-users in using technologies such as smart meters. He further states that, *"there will be a lot of local markets, meaning that there will a group of end-users trading energy on the local market level. There will be various energy communities established by end-users. This implies the emergence of local energy suppliers in all different forms. Ancillary services will be provided to the end-users by Energy Service Companies (ESCOs). These services include information supply about the best time to consume energy or deliver it back to the system. It can also be information about buying a different kind of smart appliance than the existing one in order to save costs, and various maintenance services. A number of new service functions will need to be put into the system to be able to support the new energy type of products that are emerging and creating a*

balance between the existing suppliers and new energy communities. There will be new companies building their own energy communities and energy business is currently being developed throughout Europe. Technologies are also being developed for niche markets. For example, a company like Tesla is not only providing electric vehicles, but also building up a completely smart charging infrastructure throughout Europe. This is in order to ensure that the end-users can drive all around Europe without disturbances. There are currently not a lot of products in the market, and this could be attributed to not having a good strategy in developing new products and services. A better strategy will therefore be required in order to develop new products and services for the future energy market". He further adds that various displays have been provided (for instance Toon display from Eneco), that give insight into household energy use. However, there is not a new service that will support the end-user in usage of the mounted equipment. This in his opinion will create an added value for the smart meter. There are currently limited smart energy products that support the smart meter. There is thus a huge gap between the existing practice and moving it to an area that requires new way of dealing with the system.

The technical project leader of Returns for Everybody said that a big challenge in future product and service development is to make simpler, more interpretable and understandable versions of already existing tools such as user interfaces. This, in her opinion, could support active involvement of people with little technical experience that want to be active with energy. She also stated that different end-user segments should have tools that match their knowledge and experiences. For instance, one of the pioneer ambassadors in their project in Amersfoort is quite old-fashioned, and does not own a smart phone. However most of the tools developed to increase energy usage insight are connected to smart phones. This ambassador usually prints out the energy display data to ask for an explanation of their meaning. She further stated that there are two categories of users, those with technical know-how and those without. It is therefore important keep them involved and attracted to products.

For the participant in the PowerMatching City project, tools and means to influence or control the usage of solar photovoltaics (such as weather forecasts) should be provided to the users themselves so they can balance and regulate their usage of renewable energy instead of automatic balancing done by the PowerMatcher software.

With regards to the requirements that should be met for developing future products and services, 6 out of 9 respondents stated that end-users should be the starting point in the development process. Although end-users currently take part in various co-creation workshops, they are mostly aimed at evaluating and improving products and services offered in the projects. According to the project manager from Smart Grids Lochem, *"end-users mainly help to evaluate the use of the products, but not very much in product and service development. This is actually a problem"*.

From an end-user's point of view, the residential end-user in the PowerMatching City project stated that end-users want to be more involved in future product and service development process, contributing their views and insights. This, he said, will help to create products that can be easily understood and communicated with. He stated, *"there is a need for end-users to define what they want, and also the need for product and service developers to be close to the end-users, and know what their wishes are. This makes new product features accessible and understandable."*

He further stated that product and service functionalities that give end-users more control over their energy generation and use options will help to improve energy efficiency and increase local renewable energy generation.

The consultant from PowerMatching City was of the opinion that a lot of technology-based products and services do not always consider the implication for the end-users who are going to use them. He advocated that product and service developers should look from the perspective of what end-users need, as this proves a better approach than trying to push technology.

The developer from Your Energy Moment suggested the use of an iterative design approach, and starting with small steps (e.g. creating simple and less complicated products and services) in product and service development.

Table 3.3. Overview of major interview findings

Respondents	Project stakeholders	Current products and services	End-user involvement through	Product & service development approach	Requirements for future product and service development
<p>Power-Matching City Groningen</p> <p>1. Consultant, 2. Project Leader, 3. Project developer 4. Participant</p>	<p>European Union, Grid operator, Energy supplier, Local energy cooperative, Municipality, Gas company, ICT company, Research institute, Energy consultancy company, Knowledge institutes (n=3), End-users</p>	<p>Micro-generators, Smart meters, Energy storage systems, Electric vehicles, Energy monitoring and control systems, Smart appliances, Dynamic pricing, Powermatcher (energy matching software), User interfaces (e.g. smart thermostats)</p>	<p>Co-creation activities and sessions, Evaluation of existing products and services</p>	<p>1.2.3.4.) No standard design approach, mainly developed from a technical perspective</p>	<p>1.2.3.4) A better incorporation end-user requirements, An integrated design approach with all stakeholders (including end-users), Integration of various products and services 4) Developing more modular products, Simplification of elements of current products and services</p>
<p>Your Energy Moment Zwolle/Breda</p> <p>5. Researcher/ Developer</p>	<p>Grid operator, Local energy cooperative, Housing corporation, Energy supplier, Product supplier, Knowledge institute, Renewable energy supplier, End-users</p>	<p>Micro-generators, Smart meters, Smart appliances, User Interfaces (e.g. smart thermostats), Smart plugs, Dynamic pricing</p>	<p>Workshops and meetings where end-users' ideas and opinions are incorporated in the product and service development process</p>	<p>Use of supplier-client model where the supplier incorporates end-user wishes in product development. Hardware and software are developed by product developers</p>	<p>A more iterative process in product and service development, Co-creation with all stakeholders, Creating less technical and more intuitive products and services</p>

<p>Returns for Everybody Amersfoort/ Utrecht</p> <p>6. Technical project leader</p>	<p>Provincial and municipal governments, Grid operator, Neighbourhood association, Product and service supplier, Energy consultancy company, Renewable energy consultancy company, Knowledge institute, Energy company, End-users</p>	<p>Micro-generators, Smart meters, Shared electric cars, Energy usage insight, Weather prediction of energy generation from photovoltaic installations, Information on solar energy availability, Dynamic pricing, Solar energy storage, Automated control of smart appliances</p>	<p>Co-creation activities where end-users' insights are integrated in the product and service development process</p>	<p>No standard design approach, Use of already existing products</p>	<p>Developing simplified tools together with end-users to make products and services more attractive</p>
<p>Cloud Power Texel</p> <p>7. Project coordinator</p>	<p>Local energy cooperative, Grid operator, Product and service supplier, ICT company, End-users</p>	<p>Micro-generators, Smart meters, Smart plugs/thermostats, Energy monitoring and control systems, "Kiek" in-home display, energy management system, Cloud power (energy matching software)</p>	<p>Workshops to generate new product and service ideas, Input from all project partners via focus groups</p>	<p>Products designed with inputs from all project partners</p>	<p>Redesigning/ Improving elements of current products and services, energy usage insight, use and prices, and more focus on energy storage</p>
<p>Smart Grids Lochem</p> <p>8. Project leader 9. Project manager</p>	<p>Local energy cooperative (end-users), Grid operator, Knowledge institute, Product and service suppliers (n=2), Energy supplier</p>	<p>Micro-generators, "Mpare" smart meter, Energy storage systems, Electric vehicles, Non-intelligent charging infrastructure, Energy monitoring and control systems</p>	<p>Co-creation workshops, Mission and vision sessions with stakeholders, Evaluation of offered products, End-users are not very much involved in the process</p>	<p>8.9.) No integrated approach in developing current product concepts</p>	<p>8.) Closeness of product and service suppliers to end-users, Integration of various products 9.) Learning from the end-users in practice to find out what their needs are, Simplifying current products to reduce complexity</p>

3.7 Discussion and conclusions

In this section, we will reflect on the main research questions of this study, which are: (1) How have some typical residential smart grid pilots in the Netherlands been set up? (2) Which stakeholders are involved in these pilots?, (3) What are their views and perceptions with regards to the development and performance of residential smart grids? and (4) What do these stakeholders think about products and services that may support an active participation of end-users in a smart energy home?

Using insights from the Strategic Niche Management (SNM) process of building of social networks and learning in innovations, our study shows that the European Union, national, provincial and municipal governments, grid operators, energy suppliers, household end-users, product and service suppliers, Information and Communication Technology (ICT) companies, knowledge institutes and local energy cooperatives are currently involved in residential smart grid pilots. The grid operators currently play a leading role in the implementation of these projects.

Regarding the development and performance of residential smart grids, insights from our study show that a technology-push approach currently exists in smart grids products and services development, with a dominance of the perspectives of the technical partners involved in the projects. This has resulted mostly in functionally attractive, but rather technically complex products and services that end-users do not always easily understand and interact with. Also, there is a lack of integrated approach in products and services development.

A general opinion among the stakeholders is that a better incorporation of user perspectives, especially at the early stages, will be required in order develop products and services that support an active participation of end-users in a smart energy home.

It can be concluded that learning processes in residential smart grids is still very much focused on the developing and testing of various smart grid technologies, but to a lesser extent on how to 'co-shape' technology innovations in smart grids with potential users from an early stage. We therefore recommend that a better alignment of technology development and the user environment would be required for future developments leading to better smart grid products and services.

In more detail, we can conclude from the interviews that currently the main stakeholders involved in the setting up of residential smart grid initiatives are the government, grid operators, energy suppliers, various product and service suppliers, end-users (as an energy cooperative or individual households). However, the grid operators currently play a leading role. This was expected, given that they need to explore new ways of effectively accommodating various renewables and decentralized energy generation in their grids in order to optimize the entire energy system and reduce peak load in the electricity network (Gangale et al., 2013). However, a general perception held by almost all respondents was that end-users are key for a successful development and implementation. Despite this recognition and involvement of end-users in various co-creation workshops, almost all respondents revealed that current products and services offered in most of the projects, are very attractive, but appear to be too technically-complex for most end-users. These complexities result mainly from the way smart grid

initiatives are currently set-up, and how the products and services have been developed, namely with dominantly technical approaches originating from the fields of electrical engineering, power systems and digital technologies. The perspectives of the technical partners involved in residential smart grid projects, such as grid operators, energy suppliers and product and service suppliers, were mainly the starting point of the development of these products and services. These products and services include energy monitoring and control systems, in-home displays, energy generation and usage information, and home energy management systems. Some of these products and services include the provision of very detailed graphical and technical information which is often not understood by end-users.

A study of how users experience and interact with an Energy Management System (EMS) concludes that in order to change people's behaviour to shift their electricity consumption to match the local supply, it is important that designers implement the system in a way that user interaction is not perceived as being cumbersome (Kobus et al., 2012). The study further suggested that the EMS interface should have an intuitive design that enables users to directly use the system without having a good deal of prior knowledge, as certain users would prefer simple interfaces with limited information, while others would require comprehensive insights in their electricity production and consumption.

This implies that the way users and the energy system interact is an important aspect of user involvement as active participants in balancing energy demand and supply (Verbong et al., 2012). Therefore, technical complexity of products and services offered in residential smart grids could affect how end-users interact with these technologies. This complexity could further limit changes in energy behaviour by end-users, required to balance energy demand and supply in a smart grid.

The development of simplified, less cumbersome products and services that end-users can easily use and interact with could support their role as energy citizens and active participants in a smart grid (Chappells, 2003; Sauter and Watson, 2007; van Vliet et al., 2005). This simplification could support a better end-user engagement with smart grid technologies, adjustments in behaviour to reduce energy consumption, and a better use of renewable energy technologies (Kobus et al., 2012, Geelen et al., 2013c; Stern, 2014).

This study also highlights that already existing products and services are usually procured by various product and service suppliers and used in these projects, with end-users mainly evaluating the functioning and performance of these products and services, and providing feedback on what should be improved. Most often, the functioning of these technologies is not very much understood by end-users. Product and service development appears to be mainly driven by commercial desire for technical innovation, and thus an integrated approach in product and service development is now lacking.

Simplification of smart grid products and services could imply the development of simple "plug and play" tools and devices that are manually controlled and provide limited and more understandable information (Sauter and Watson, 2007; Wolsink 2012). These "plug and play" tools could support end-users to better manage and control their energy usage and generation options, than the advanced, automated technical solutions that mainly work in the background, with limited end-user interaction. Therefore, in order to create improved, more simplified, intuitive and user-friendlier smart grid products and services, a User-Centred Approach (UCD) (Wever et al., 2008) should be employed.

Though user perspectives are currently incorporated in developing smart grid products and services, their involvement is still very much limited to the evaluation of the performance of pre-determined products and services offered in residential smart grids. This makes them mere passive recipients of pre-determined solutions.

A better alignment of technology development and the user environment could be required in future developments. This will help to 'co-shape' technology innovations in smart grids with potential users from an early stage.

A technology-push approach and a lack of integrated approach in the development of smart grid products and services could limit the adaptations of these technologies by end-users, and the success of future implementation of smart grids.

Hence, based on the findings of this study, we propose a more active involvement of end-users and a better cooperation with all the relevant stakeholders in smart grid product and service development process. This will help to create products and services that better meet end-users' needs in a smart Grid context.

Reflecting on the theoretical framework of Strategic Niche Management (SNM) used in this study, this study has shown that the use of SNM has re-affirmed our earlier findings in the literature as presented in chapter 2, namely the limited involvement of end-users in smart grids products and services development. The use of SNM shows that learning processes on the user side of appears to be limited. It showed that a good learning process in smart grid projects is still missing. The learning process related to products and service development is a bit narrow, focussing mainly on technology development and optimization, and to a lesser extent on user involvement in developing these products and services.

The use of SNM was very useful in establishing the actual status of residential smart grid projects and the level of involvement of the various stakeholders.

This study provides indicative rather than conclusive findings due to the limited number of respondents per project (n=9) and projects explored (n=5), and the limited comparability between the projects. For instance, one of the projects in this study (PowerMatching City I) started up as a technical pilot that focused on exploring the technological feasibility of integrating various renewable energy sources. This is in contrast to the other four projects that were more bottom-up and were initiated by end-users.

However, the value of this study, despite having limited statistics, is that it is one of the first studies that focuses on exploring the views of a broad range of stakeholders involved in residential smart grid projects.

Chapter 4 Evaluation of energy performance and user experiences in residential smart grid pilot projects

This chapter is based on:

Obinna, U., Joore, P., Wauben, L. and Reinders, A. (2017) Comparison of two residential Smart Grid pilots in the Netherlands and in the USA, focusing on energy performance and user experiences. Applied Energy 191 (2017) 264–275.

4.1 Introduction

Chapter 3 employed a qualitative exploratory approach to investigate the views and perceptions of stakeholders involved in the development and implementation of residential smart grid pilot projects. This was directed towards the set-up and implementation of residential smart grid projects, the involvement of end-users stakeholders and end-users in these projects, the performance of these projects, and the functioning of products and services implemented in these projects.

With regards to products and services offered in residential smart grid projects, Chapter 3 showed that currently a technology-push approach exists that originates from the technical partners involved in smart grids development. The lack of an integrated approach towards smart grids products and services development has in most cases resulted in technically-complex products and services that cause issues with end-users' understanding of these products.

An important aspect regarding the functioning of products and services implemented in residential smart grid projects is how end-users experience their interaction with these products and services, and to what extent their implementation has supported end-users in becoming co-providers in a smart grid.

Since the insights obtained in Chapter 3 were mainly based on a qualitative approach, this chapter will employ a more quantitative approach to explore the energy performance of households participating in a smart grid in relation to the experiences of these end-users.

This chapter is structured as follows: Section 4.2 presents the background and objective of this study. Section 4.3 describes the smart grid projects in which participating households were evaluated. Next, the research method, including the data collection and analysis approach is presented in section 4.4. Section 4.5 presents the results of the analysis and evaluation, followed by discussion in Section 4.6 and conclusions in Section 4.7.

4.2 Research background

What insights can be gained from evaluating current residential smart grid pilots from a user perspective, in particular with regards to the energy performance of products and services implemented in these projects? Since this study is partly quantitative, the sub-research questions formulated for this study are 1) What differences could be observed in the energy performance and experiences of households in residential smart grids in the Netherlands and in the USA? 2) What factors are responsible for these differences be attributed to?

Providing answers to this question could help to support the successful deployment of future residential smart grids.

As stated in the preceding chapters, new energy products and services implemented in smart grid households are expected to support end-users to have greater management ability over their energy consumption, and take part in energy management in a smart grid (Darby and McKenna, 2012; Geelen et al., 2013). In addition to the implementation of

these products and services, end-user interaction with these products and services is considered a requisite for a more active participation and involvement of end-users in smart grids (Verbong et al., 2012). However, many of the energy efficiency measures currently being implemented are very much focused on technology adoption (Verbong et al., 2012; EEA, 2013). Therefore, interaction between end-users and new energy technologies still remains challenging (EEA, 2013).

Previous chapters have concluded that end-user behavior and practices will complement the functioning of smart grid products and services, and support an active end-user participation in smart grids. However, there is currently little knowledge available regarding the participation of end-users in smart grid projects, and their experiences and interaction with the novelties introduced in these projects. The exception being the studies conducted by (Reinders et al. 2012, Kobus et al., 2012; Van Dam et al. 2012).

These previous studies have, however, been limited to individual smart grid pilots, or evaluation of a limited number of participating households.

Also, little is still known about the energy performance of households in smart grid pilots with strong user involvement, as smart grid technologies are only recently available (Geelen et al., 2013). In addition, a comparison of user experiences and energy performance from two different smart grid pilots has currently not been carried out.

This study seeks to fill this gap by:

- 1) Comparing the design/set-up of two smart grid projects
- 2) Evaluating the energy performance of these projects
- 3) Assessing how existing smart grid set-ups influences user behavior: demand patterns and energy-efficiency.

Evaluating and comparing user experiences and households' energy performance in a smart grid will help to provide representative insights regarding how current smart grid products and services influence energy generation and consumption behaviors in smart grid households.

The projects, which have been evaluated and compared in this study, are: (A) PowerMatching City in Groningen, The Netherlands, and (B) Pecan Street in Austin, Texas, USA. These projects were chosen because (1) they exist already sufficiently long (namely from 2007-2015) to have been evaluated and monitored, for which reason reports and data are available at the moment; (2) the projects served as short cases of early smart grids in residential areas, were some of the co-authors of this paper were previously engaged as researchers; (3) of the strong focus of the projects on user involvement and participation in energy management in a smart grid.

In this study, the energy performance in the evaluated projects is measured in relation to the pattern of households' electricity generation and consumption. The energy performance could serve as an indicator of how the smart energy system is functioning, and the extent to which residential end-users can contribute to peak load balancing in the electricity network.

Since the evaluation conducted in this study occurred at a later stage when the smart grid pilots were more mature and advanced, we will use the term 'smart grid projects', instead

of 'smart grid pilots' in this study. This distinguishes this study from earlier studies focusing on the evaluation of residential smart grid in which pilots were at the infancy stage and the implemented technologies were still very new to the participants. In contrast, the projects evaluated in this study have been running for a large number of years.

4.3 The Smart Grid projects

This section describes the smart grid projects evaluated in this study. As the technologies implemented in these projects are for a large part rather similar, we can compare these with each other, focusing on the energy performance and experience of the end-users in both projects. Below we provide short descriptions of PowerMatching City and Pecan Street.

A. PowerMatching City in Groningen (the Netherlands)

This project started in 2007 and was carried out in the city of Groningen, located in the Northern part of the Netherlands (Bliek et al., 2010). Technologies implemented include hybrid heat pumps, in-home energy displays, PowerMatcher energy matching software, photovoltaic systems, smart meters and smart appliances, smart thermostats, micro-combined heat and power (CHP) systems and mini gas turbines. At a distance, electric vehicles and a wind turbine were connected as well. Table 4.1 presents the technologies used.

The project focused on attaining optimum capacity management in a smart grid, and matching energy services with the demands and wishes of end-users (Bliek et al., 2010). Phase 1 of the project started in 2007 with the realization of a local smart grid with 22 homes and was concluded in 2011. It focused mainly on the demonstration of technical feasibility of the smart energy system. Phase 2 (2011-2014) explored ways to involve the residential end-users. Additional 18 homes were added in 2011, bringing the total number of participating homes to 40. The households in the PowerMatching City project were composed of an average of 3 persons, and were recruited through the network contacts of the project partners, as well as calls for participation in a local newspaper. The participants are mainly early adopters, with higher educational level and income compared to average families in the Netherlands (Geelen, 2014).

A detailed set-up of PowerMatching City is described in (Bliek et al., 2010)

B. Pecan Street Austin USA

The Pecan Street smart grid project is being carried out in Austin, Texas, USA. The project started in 2010, and is still on-going. Technologies implemented in the participating homes include: energy management systems, distributed solar photovoltaic energy, plug-in electric vehicles, smart meters, distributed energy storage, smart appliances, in-home displays, programmable communicating thermostats (see Table 4.1).

The Pecan Street smart grid project had over 1,000 participating households who shared their home or businesses' electricity consumption data with the project via green button protocols, smart meters, and/or a home energy monitoring system (Pecan Street, 2015). The households in the Pecan Street project were involved via communication in newsletters, local media, attendance at neighborhood events, and word of mouth within the targeted geographical area of the project (Pecan Street, 2015). The participants represent a diverse demographic group with an interest in new products and services. They were volunteers and early adopters, with higher educational level and income compared to average families in Texas (Pecan Street, 2015). A full description of Pecan Street is given by (Rhodes et al., 2014).

Table 4.1. Overview of technologies in PowerMatching City and Pecan Street in 2015

Technology	PowerMatching City		Pecan Street	
	Number of households	Description	Number of households	Description
Photovoltaic (PV) systems	40	2.3-7.5 kilowatt peak (kWp) - Installed on roofs of households	211	6-10 kWp (Installed on roofs of households)
		33.5 kW (Virtual production)		
Smart meters	40	Kamstrup smart meter (type 162 j nta/382 j nta)	1000	Landis+Gyr E350 meters
Home Energy Management Systems (HEMS)	40	Heating systems: Hybrid heat pumps (Samsung 4.5 kW thermal power output), Gas-fired micro-cogeneration units (14 kW thermal), hot water tank (210 litres), Condensing boiler: Intergas, 20 kW thermal power output	3	Micro-cogeneration units, Geothermal heat pumps
		Micro-combined heat and power (CHP): (Whispergen, 6kW thermal and 1 kW electrical power output), 6 kW thermal (auxiliary	23	Hybrid heat pumps

		burner)		
		User interfaces: manual thermostat, energy portal, community portal, appliance interface	750	User interfaces: Smart phone/tablet apps (Pumpkin Pie), web interface, Online portal, Eguage system, In-home displays, Eguage system Mobile app (Pumpkin Pie) Energy portal, community portal, smart meter interface
	40	PowerMatcher (automatic coordination mechanism)	Not applicable	
	12	Smart appliances: Dishwasher/washing machine (Miele@Home technology)	13	Smart appliances: LG electronics smart refrigerators, LG smart clothes washer and dryer
Smart thermostats	40		240	
Energy storage	Not applicable		Pecan street lab	Valence Technology kWh lithium-ion magnesium phosphate batteries,
Electric vehicles	10	Electric Volkswagen Variant 5	72	Chevy volt/Nissan leaf Chevy volt (17.1 kWh) and Nissan leaf (24 kWh)

With regards to the Photovoltaic (PV) system installed in the PowerMatching City, the term 'virtual production' means that households generate PV solar energy via submetered production of a nearby PV system (virtual coupling) and not their own PV installation (for instance, via sub-metering of a PV system on a different building). The

group of houses connected via virtual coupling can therefore be controlled as a Virtual Power Plant (VPP).

4.4 Research Method

4.4.1. Data collection

Available information in 2013 to 2014 was compared, such as (1) electricity generation and consumption data of active households with single-family homes participating in the two residential smart grid projects (see Table 2), and (2) quantitative analysis of user questionnaire surveys.

We used existing reports and data available by data portals, project websites and reports. For the PowerMatching City project, existing studies and reports (Geelen, 2014; PowerMatching City, 2014) with results of interviews and questionnaire surveys of participating users were evaluated. Authorized persons in the PowerMatching City project, that had access to the database, retrieved the electricity meter readings used for the energy performance analysis.

We focused on the years 2013 and 2014 because complete data related to electricity generation and consumption of households in both projects was available for those years. This was not the case in the preceding years, where missing data related to electricity generation and consumption was reported in many households.

Table 4.2. Sources of information used for this study

	PowerMatching City	Pecan Street
Energy performance evaluation	1) Database containing monthly meter readings of electricity consumption and generation of 21 single-family households (PowerMatching City, 2016)	1) Database containing hourly meter readings of electricity consumption and generation data of 85 single-family households (Pecan Street, 2016)
User experiences	1) Thesis Report containing quantitative survey results of user experiences between 2009 and 2014 (Geelen, 2014) 2) Final report of the working group customer research (2014) with results of user experiences with the implemented smart energy system (PowerMatching City, 2014)	1) Final Technology Performance Report February 2015 (Pecan Street, 2015) 2) Data portal of Pecan Street organization containing results of questionnaire surveys of 333 participating households in 2014 (Pecan Street, 2016)

In order to characterize the energy performance in the households that were part of the pilots, the following information was extracted from the meter readings:

- Amount of electricity consumption per household
- Amount of electricity generated per household
- Amount of electricity withdrawn from the grid

These extracted data were described in terms of monthly averages.

B. Data analysis

An analysis of the electricity generation and consumption took place in order to gain insight in the balance between electricity generation and consumption of the households. The e-gauge readings for hourly intervals extracted from the data portal of the Pecan Street project (Pecan Street, 2016) were converted to monthly averages for the group of households. The hourly meter readings from PowerMatching City households were converted to monthly generation and consumption data for the individual households.

In order to complement the data analysis, we conducted a desk research to explore factors that could influence the energy consumption of the households.

4.5 Results

A. Electricity generation and consumption

Figures 4.1 and 4.2 show the total average monthly electricity generated, consumed and taken from the grid in the selected households in the PowerMatching City and Pecan Street projects, respectively.

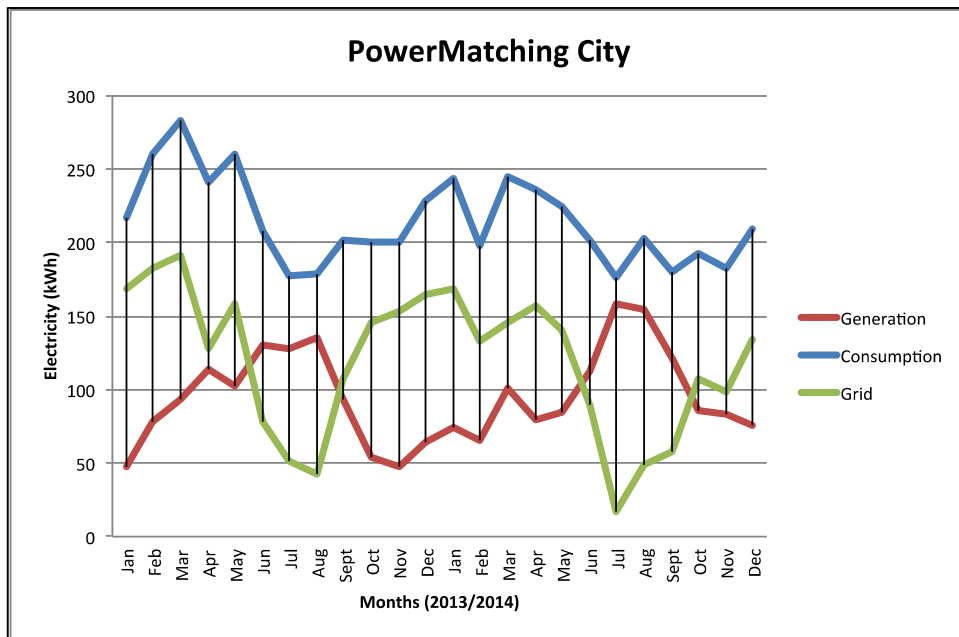

Figure 4.1. Average monthly household electricity generation, consumption, and usage from the grid (grid) in PowerMatching City 2013-2014.
Source: (PowerMatching City, 2016)

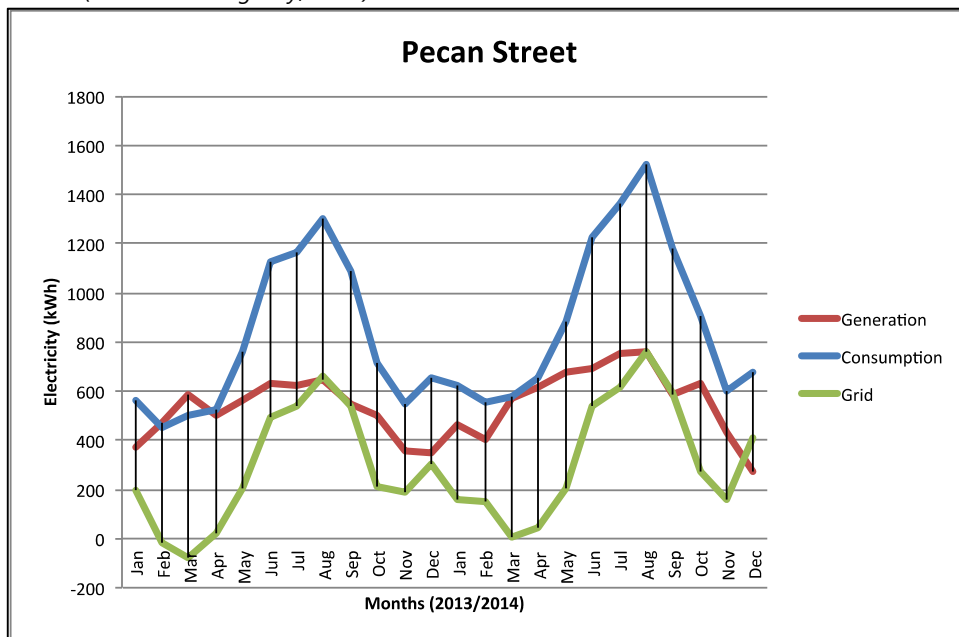

Figure 4.2. Average monthly household electricity generation, consumption, and usage from the grid (grid) in Pecan Street 2013-2014
Source: (Pecan Street, 2016)

A1. PowerMatching City

Figure 4.1 indicates that in 2013, the total average electricity consumption of the selected households in PowerMatching City was 2656 kWh.

The highest monthly average electricity generation was about 136 kWh, and this was recorded in the month of August.

With a value of 284 kWh, the highest total average electricity consumption was reported in the spring month of March.

The highest average electricity taken from the grid was in February, with a value of 191 kWh.

In general, the lowest average electricity generation is observed in the autumn months (October, November) and the winter month of January, while the summer months of July and August accounted for the lowest average electricity consumption in the households and from the grid.

In 2014, the total average electricity consumption of households in PowerMatching City was 2490 kWh. The highest average electricity consumption occurred in March, with a value of 245 kWh.

The highest monthly average electricity generation was 159 kWh, and this was registered in July.

The highest average electricity used from the grid was 168 kWh (January).

Similar to 2013, the average electricity generation decreased from the autumn months to the winter months. The lowest electricity consumption in households and from the grid occurred in the summer months.

A2. Pecan Street

Figure 4.2 shows that in 2013, the total average electricity consumption of households in Pecan Street was 9,408 kWh. With a value of 1305 kWh, the highest total average electricity consumption took place in August.

The highest total average monthly electricity generation was 643 kWh, and this took place in August.

The highest average electricity taken from the grid was 662 kWh, and this was registered in August.

The winter months accounted for the lowest generation and consumption, while the spring months were responsible for the lowest electricity used from the grid.

In 2014, the average electricity consumption of households in Pecan Street was 10756 kWh. The highest consumption occurred in August, with a value of 1520 kWh.

The highest average electricity generation of 763 kWh was registered in August.

Similar to 2013, the winter months accounted for the lowest average generation and consumption, while the lowest electricity used from the grid occurred in the spring months.

In general, the electricity consumption of the households increased from the spring months to the summer months, and reduced from the autumn months to the winter

months. The electricity generation and the electricity used from the grid also followed the same pattern as the consumption. Tables 4.3 and 4.4 present the total averages related to electricity generation, consumption and usage from the grid of households in PowerMatching City and Pecan Street.

Table 4.3. Total yearly average electricity generation, consumption and usage from grid by households in PowerMatching City

Year	Average Generation (KWh)	Average Consumption (KWh)	Average used from Grid (KWh)
2013	1086	2656	1571
2014	1194	2490	1296
% change 2013-2014	+10%	-6%	-18%

Table 4.4. Total yearly average electricity generation, consumption and usage from grid by households in Pecan Street

Year	Average Generation (KWh)	Average Consumption (KWh)	Average used from Grid (KWh)
2013	6139	9408	3461
2014	6847	10756	4290
% change 2013-2014	+12%	+14%	+24%

From the values in Tables 4.3 and 4.4, we calculated the percentual changes in yearly average electricity generation, consumption, and usage from the grid in PowerMatching City and Pecan Street. The average electricity generation in PowerMatching City was 10 percent higher in 2014. The consumption was 6 percent lower in 2014, while the percentage of electricity used from the grid was 18 percent lower in 2014.

The average electricity generation in Pecan Street households was about 12 percent higher than that of 2013. The consumption was 14 percent higher than in 2013, while the average electricity used from the grid was about 24 percent higher in 2014.

B. Electricity generation and consumption comparison PowerMatching City and Pecan Street

A comparison of electricity generation and consumption of households in both pilots was made. It could be observed that the electricity generation and consumption in PowerMatching City was far lower compared to Pecan Street. In 2013 and 2014, the

average electricity generated by households in Pecan Street was about 5 times higher compared to households in PowerMatching City. The average electricity consumption in the group of households in Pecan Street was also 4-5 times higher compared to households in PowerMatching City in 2013 and 2014. In addition, households in Pecan Street used 2-4 times more energy from the grid compared to households in PowerMatching City in 2013 and 2014.

While the summer months accounted for the peak in electricity consumption in Pecan Street in both years, the winter months were responsible for the peak average electricity consumption in PowerMatching City.

Figures 4.3, 4.4 and 4.5 show a comparison of the averages for generation, consumption and grid respectively.

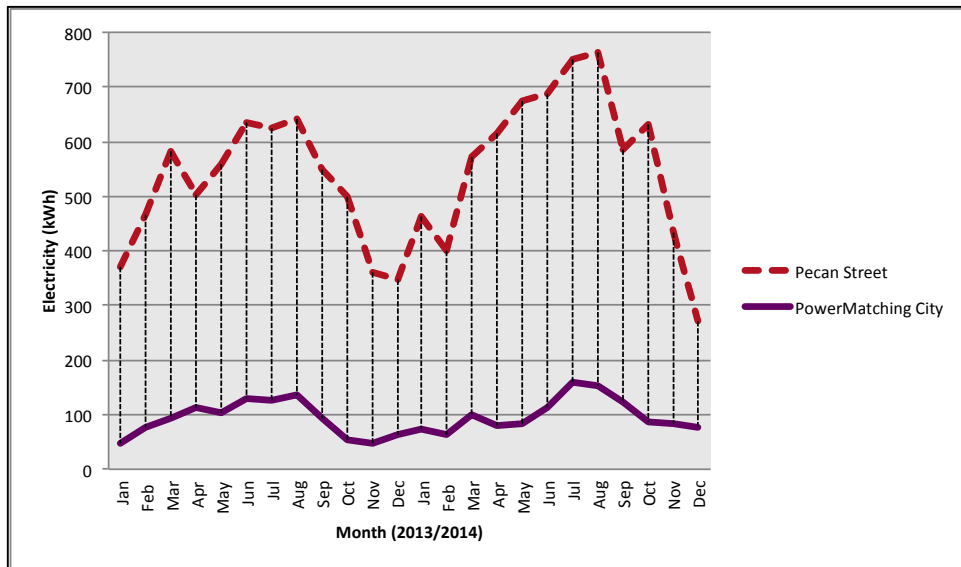

Figure 4.3. Comparison of average monthly household electricity generation in PowerMatching City and Pecan Street.

Source: (PowerMatching City, 2016; Pecan Street, 2016)

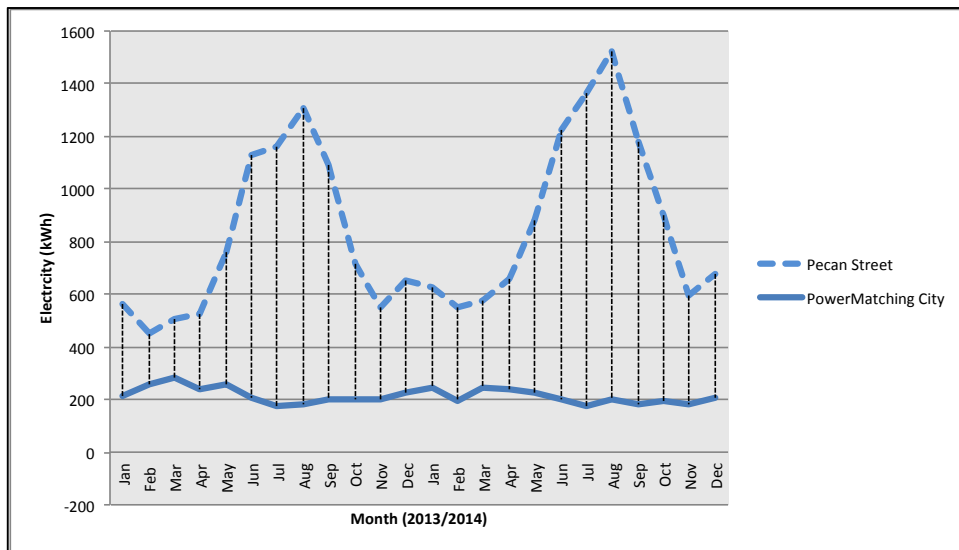

Figure 4.4. Comparison of average monthly household electricity consumption in PowerMatching City and Pecan Street.

Source: (PowerMatching City, 2016; Pecan Street, 2016)

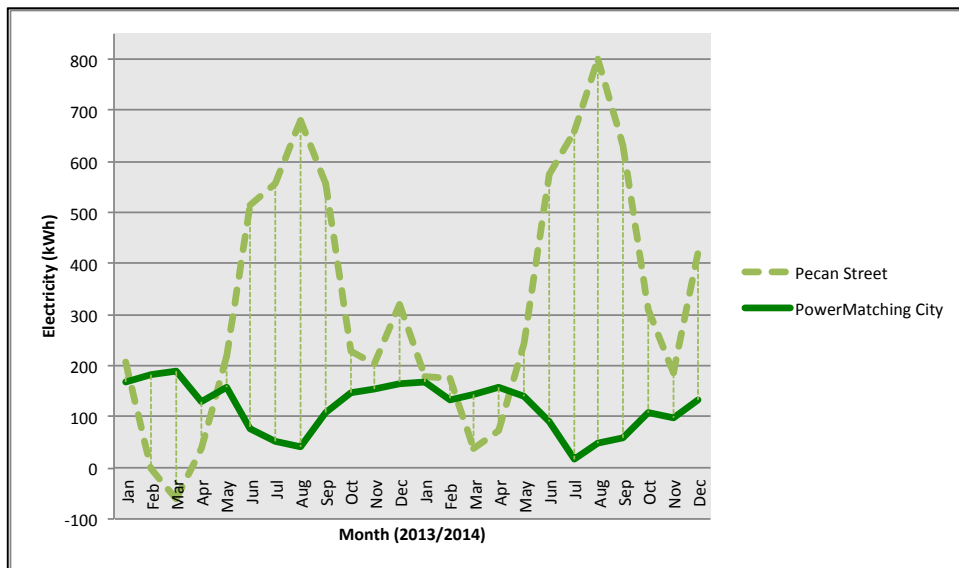

Figure 4.5. Comparison of average monthly household electricity consumption from the Grid in PowerMatching City and Pecan Street.

Source: (PowerMatching City, 2016; Pecan Street, 2016)

Comparing these values to the average electricity consumption in the Netherlands and the USA, households in both the PowerMatching City and Pecan Street consumed less

electricity than the average households in both countries in 2013 and 2014. The average electricity consumption in the Netherlands in 2013 and 2014 was 3100 kWh per year (CBS, 2016) while the average consumption for households in the USA was 10,932 kWh (EIA, 2016). The average electricity consumption of households in Pecan Street was also lower than the average in Austin, which was around 12,000 kWh per year in 2013 and 2014 (Austin Energy, 2016).

Considering the averages over the total number of households in relation to energy generation, consumption, and usage from the grid in both projects, a standard deviation calculation was carried out to provide an indication of how far the data used in this study deviates from the mean. The calculation revealed a small standard deviation, with values that are not very far away from the mean. This means that the variations in the measurements are quite minimal, and our dataset is representative.

However, since the evaluation carried out in the section above was based on the total average electricity data of the evaluated households, we decided to zoom on an individual household to get an impression of what their daily patterns of electricity generation and consumption looks like.

For this purpose, a household was randomly selected from the Pecan Street pilot project. Figure 4.6 shows the pattern of electricity consumption, generation and use from the grid on a particular day in the month of January 2013, while figure 4.7 shows the pattern of electricity consumption, generation and use from the same household on a particular day in the month of August 2013.

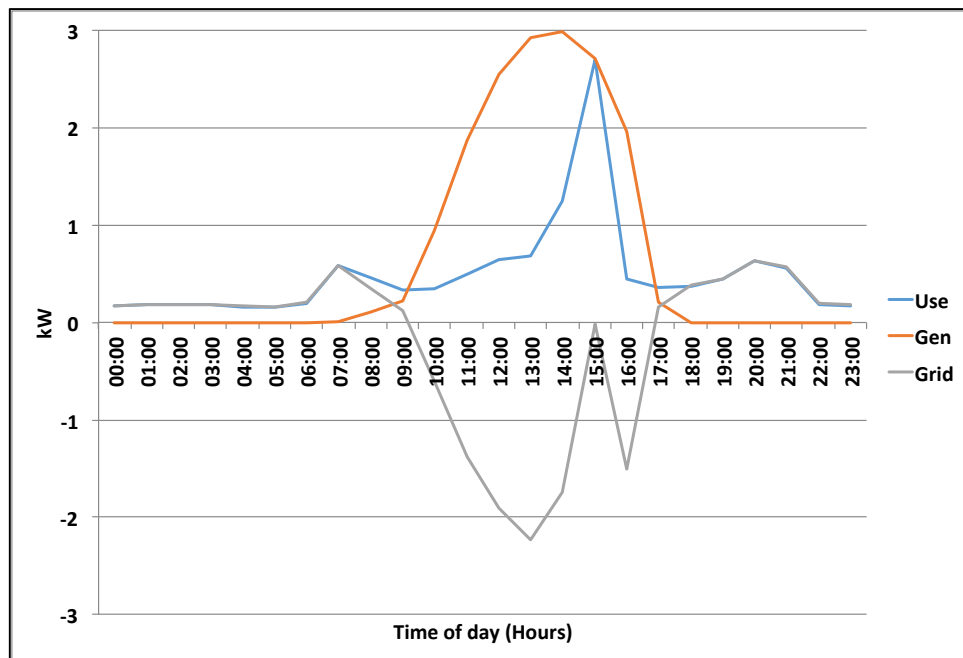

Figure 4.6 Daily pattern of energy usage of a household in Pecan street project (01/01/2013)

Source: Pecan Street

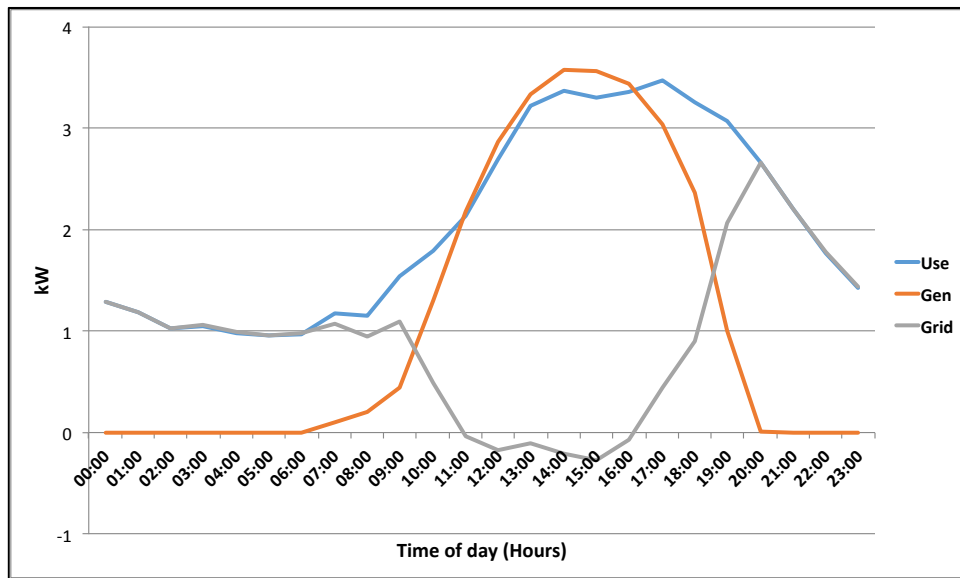

Figure 4.7 Daily pattern of energy usage of a household in Pecan street project (01/08/2013)

Source: Pecan Street

Comparing the two months (January and August) shown in the graph, it could be observed that this household consumed much more electricity during the month of August compared to January. While it can also be observed that the daily patterns of electricity use in the two months appears to be the same, much higher electricity is consumed as the temperature increases.

This particular household appears to take less energy during the period of high renewable electricity generation, implying that the self-sufficiency or autonomy from the grid is quite high.

The same applies to the winter months, when the use of air-conditioning in Texas is quite low. This household also relies on the electricity generated from solar photovoltaics for their consumption.

This example shows that the behaviour and characteristics of individual households could have significant influence on the energy performance of households.

C. Household characteristics, involvement, experiences and behaviors in both projects

The aim of this section was to gain insights in the involvement of the participants in the projects, their experiences with the implemented smart energy technologies, and behavior related to their home energy management.

C1. PowerMatching City

Participants joined the project on a voluntary basis. Two of the participants were employees of the main project consortium (DNV, GL, a Dutch energy consultancy company), and members of the project team. They took part in the design, installation and maintenance of the home energy systems.

The participants were mainly early adopters, with high educational levels (Bachelor and Master degree) and income. The average monthly income of households in PowerMatching City ranged between € 3000 and € 4000. Households in PowerMatching City have a 19 % higher monthly disposable income, compared to average families in the Netherlands, that have a monthly average disposable income of € 2900 (CBS, 2016). Households in PowerMatching City were made up of an average of 3 persons, with children between the ages of 10 and 14. The households generally have profound interest in sustainability and reducing their energy use (Geelen, 2014).

The first part of the end-user research analyzed in this study was carried out between 2009 and 2012. The questionnaire survey of users by (Geelen, 2014) revealed that more than half of the participants reported an increased awareness of energy consumption as a result of their participation in the pilot. However, minimal behavioral changes to be more active in their energy management were reported. This was attributed to the feedback and control provided. The PowerMatcher system that regulates energy demand and supply functioned at the background. This was because it was automatically programmed to switch on household appliances at times most favorable for the electricity grid. Therefore, participants did not always understand the moment that the heat pumps, micro-CHP and smart appliances switched on, since the PowerMatcher remotely controlled these. Participants, however, wanted more influence and insight in the functioning of the system. The residents reported that the manually operated appliances gave them a greater sense of satisfaction and control over the system.

The majority of the participants of PowerMatching City stated that they preferred the automatic steering of their heat pump or microCHP and the smart function of the washing machine, rather than having to adjust the devices themselves manually. This is because it costs them the least effort.

Analysis of evaluative interviews and questionnaire surveys conducted in the context of PowerMatching City by Geelen (2014) and PowerMatching City (2014) revealed that while manual thermostats were implemented in phase one of the pilot, 69% of the survey participants had preferences for programmable thermostats. This is because they were not used to the manual thermostats, and did not always routinely adjust the settings. This in their opinion resulted in limited interaction with the home energy system, and their ability to influence their energy consumption pattern. It was concluded in these studies that insights and feedback are important for a more active involvement of end-users in energy management.

These findings were incorporated in the second phase of PowerMatching City, carried out between 2013 and 2014. Two new energy services and an improved 'Energy Monitor' (web-portal) were developed and implemented. This monitoring gave more feedback into what was happening: monitoring of energy flow during the day. This created increased

interaction with the various technologies provided such as the thermostat and washing machine.

End-users were involved in developing the services and interfaces they wanted. Specifically, they were involved in developing elements of the interface of the new Energy Monitor by participating in various co-creation workshops where the future energy system was elaborated. This was to enable them to participate more actively in household and community energy management. The workshops also provided an opportunity for them to state their expectations and concerns regarding the project. The energy supplier (Essent) and the grid operator (Enexis) led the co-creation workshops, while other project partners were also involved. The first energy service developed in Power Matching City II is called "Together more Sustainable", which is aimed to ensure optimal use of renewable energy that is produced within the community. Here, energy is shared in the community, thereby promoting local energy generation and use. This is supported by a web portal, which displays information about energy use and availability to the end-users. The second energy service is called "Smart Cost Saving", which enables the end-users to keep the cost of energy generation and consumption as low as possible. These services are the ones they designed and wanted.

The Energy Monitor provided real-time insights and an improved feedback and control. It also displayed all energy flows in the home and shows overviews of the historical usage, and could also be used to adjust the thermostat. Figures 4.8 and 4.9 show a photographic example of user interfaces for an energy monitoring and control system before and after installation of the energy monitor.

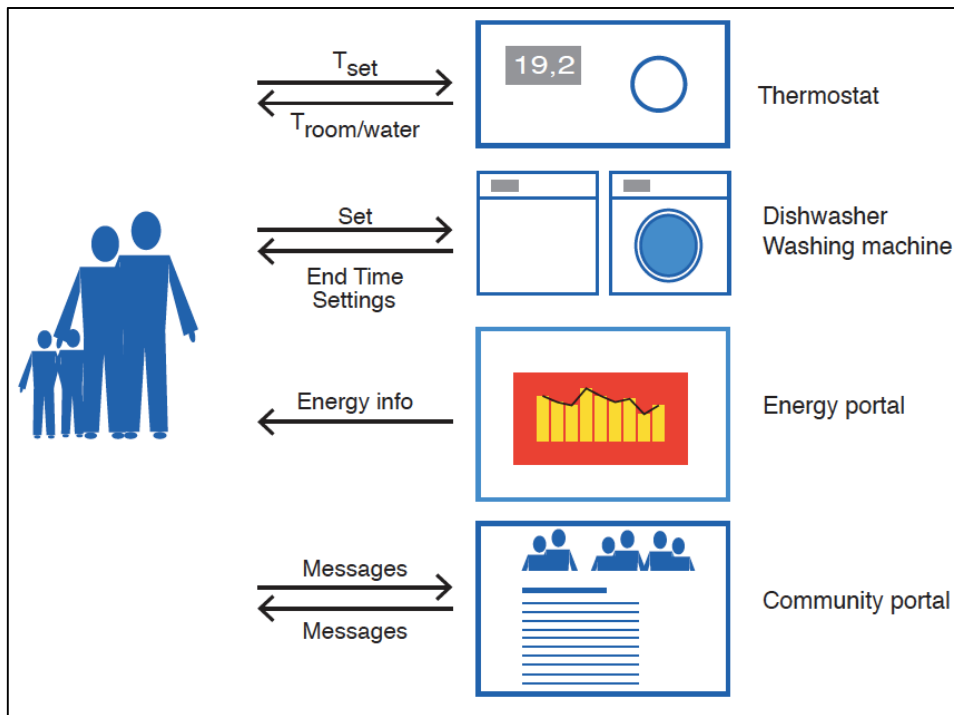

Figure 4.8a. Schematic of the user interface of the home energy system before installation of the Energy Monitor

Source: PowerMatching City, 2015



Figure 4.8b. Manual thermostat before installation of the Energy Monitor

Source: PowerMatching City, 2015

Figure 4.9a-c shows schematics of the user interfaces of the home energy system after installation of the Energy Monitor



Figure 4.9a. Insight in costs, gas and electricity use and energy savings

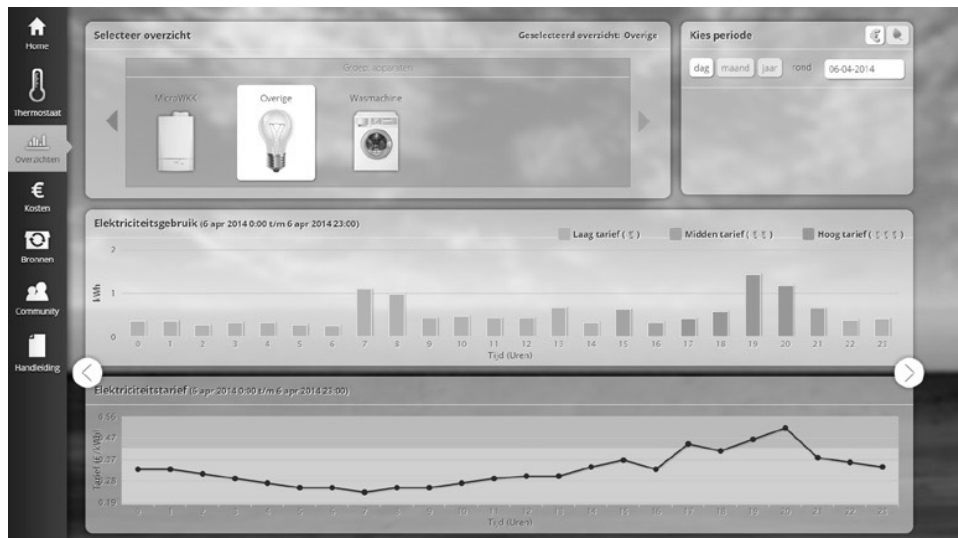

Figure 4.9b. Historical insight into energy use



Figure 4.9c. Information about the best times to switch on smart appliances

A community monitor also provided information on energy generation and consumption of the entire street, thereby supporting the residents to compare their household energy use to other households.

In total, 50% of the surveyed participants expressed satisfaction with the adapted energy monitor, since it provided clear, detailed and reliable information that made them more conscious of their energy use. They also felt more empowered to reduce their energy use. Although participants were positive about the new Energy Monitor, they did not always comprehend the information on the monitor. They still stated that they lacked complete insight and control in the operation of the smart energy system, and were not yet able to reach their energy related goals which were (a) saving energy, (b) using energy at appropriate time and suitable amounts and (c) generating own energy.

A community website was also developed for the Energy Monitor. While half of the surveyed participants were active with the website, the rest of the participants were not, because they did not find the website user-friendly enough. Moreover, they preferred to discuss their energy performance face to face with their neighbours.

The end-user research carried out by PowerMatching City shows that the end-users were satisfied with the degree of living comfort afforded by the smart energy system. However, the expectations of the households were significantly higher for the implemented Energy Services than the experiences. Half of the participants reported that the user interface did not provide adequate control and energy feedback to support an active contribution to balance supply and demand.

C2. Pecan Street

Participants in Pecan Street were recruited through advertisements in newsletters, local media, attendance at neighborhood activities, and word of mouth within the targeted geographical area of the project (Pecan Street, 2015). To support the incorporation of the participants' perspectives in the project implementation, two people were selected via a competitive application process to serve on the Executive Committee (Pecan Street, 2015).

Like participants in the PowerMatching City, they were volunteers and early adopters, with higher educational level and income compared to average families in Texas (Pecan Street, 2015). The households in the Pecan Street pilot were composed of an average of 3 persons, with one-third of the households composed of children between the ages of 5 and 18. They had an average yearly income of between \$ 75,000 and \$ 300,000. Their disposable income was higher than the average disposable income \$ 54,000 per year for the USA (United States Census Bureau, 2016).

Participants in Pecan Street pilot were interested in reducing their carbon footprints, and saving money on energy bills. Over 200 participants took advantage of Austin Energy and Pecan Street's incentive program and installed rooftop PV systems, acquired energy-efficient appliances, such as air-conditioning compressors, and made retrofits insulation and air-conditioning duct repairs in their homes. In total, 69 households also purchased or leased an electric vehicle through these incentives, and received an electric vehicle-charging platform from Pecan Street (Pecan Street, 2015).

The majority of technologies implemented in the project were pre-market or new to market. Pecan Street's electricians installed the thermostats and participants were provided with an in-person training and handbooks describing how to program and operate the thermostats (Pecan Street, 2015).

In total, 86% of the 333 households that completed the Pecan Street user questionnaire survey had smart programmable thermostats installed in their homes. One of the questions in the survey was related to how the participants use the thermostats and other devices in their homes. Overall, 66% of the households that had programmable thermostats reported programming their thermostat settings, while 34% did not. Those who did not program their thermostats found them moderately difficult or very difficult to operate. Two participants mentioned that they could save a lot more energy if they understood the high-tech thermostats. In the words of one participant, "they have geeks design the program, need to have fifth graders do it for 1, 2, 3 steps that are easy to follow, not complicated". Most of the participants, however, expressed satisfaction with the system implemented, especially the software and application that provided periodic report and online monitoring of electricity generation, usage and costs.

With regards to energy usage behavior, the analysis of the questionnaire surveys from the Pecan Street revealed that:

- 18% of the participants have their electronic devices, such as computers and security devices constantly switched on.
- 4% of the households owned more than two computers.

- 56% of the households had a household member spending a considerable amount of time at home every day of the week.
- 20% of the residents work from home, and most often have their appliances and electronic devices plugged in.
- 11% of the households leave interior and exterior lights on when not at home to light their garages, hallways, kitchens, porches, and their entire compounds.

With regards to the use of programmable thermostats, a basic energy portal that provided information about electricity generation and consumption supported the control of the thermostats. Pecan Street Organization has also revealed that 82% of the participants who took part in a biannual survey reported using the provided portal to monitor their energy use on a daily basis, while 12% never consulted the portal. A majority of participants (84%), however, reported that they had become more conscious of their electricity use as a result of information they received through the portal that shows appliance-level electricity use. This awareness improved their energy behavior such as; switching off lights, fans and appliances when not needed; setting air-conditioning systems to a higher temperature when not at home; and hang-drying clothing instead of using an electric dryer. The remainder of the participants that had access to the online portal reported no behavioral change. They attributed this to a lack of actionable information that could support behavioral changes.

Most of the respondents in the survey expressed satisfaction with the energy monitoring for their solar panels and electric car, and an increased awareness about their energy use.

D. Factors influencing household energy performance

Based on the results of this study, we considered factors that could have influenced the electricity consumption and generation patterns of households in both projects. This was based on desk research of literature related to energy use in households. The influencing factors were thereafter related to the prevailing contexts of the evaluated smart grid projects.

From a literature perspective, the following factors influence the energy consumption of households (Vringer, 2005; Guerra Santin, 2009; Entrop, 2013):

- 1) Environmental characteristics: such as availability of solar irradiance and outdoor temperatures
- 2) Occupational characteristics: such as how energy is used in households
- 3) Building characteristics: such as the type and age of buildings, insulation, heating systems, floor surface, and type of energy used
- 4) System characteristics: such as cooling and ventilation systems
- 5) Types and usage of appliances

With respect to environmental factors, the local climate or environment in which houses are located have a major influence on the energy use (Entrop, 2013). In this regard, the outdoor temperature, the availability of solar irradiance and the wind velocity are important factors that should be taken into account. When the outdoor temperature is

close to the desired indoor temperature, little or no energy is needed for heating or cooling (Entrop, 2013).

Concerning energy generation, abundance of solar irradiance can be used directly to heat and light internal living space, or indirectly in systems that are capable of storing and/or transforming it, such as thermal solar collectors and photovoltaic panels (Grondzik et al., 2010).

Therefore, we explored the potential effect of local climatological conditions, such as solar irradiation and temperatures, on electricity generation and consumption patterns in both pilots. Figure 4.10 shows the average monthly global irradiation in the Netherlands and in Austin for 2013 and 2014.

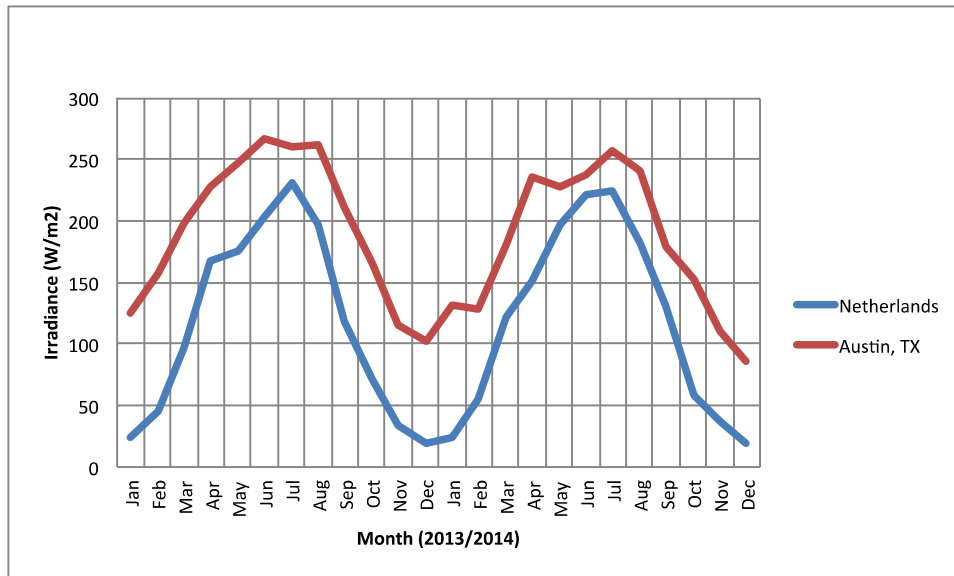

Figure 4.10. Average monthly global irradiation in the Netherlands and in Austin (TX) in 2013/2014

Source: (KNMI, 2016; US climate data, 2016)

It can be seen from Figure 4.10 that, in 2013 and 2014, the total average irradiation in the Netherlands ranged between 25 to 230 Watts per meter squares (W/m²). This is about 31% lower than average irradiation of 80 to 270 W/m² in Texas for the same period. While the average irradiation in the Netherlands was 2.5% higher in 2014, the irradiation in Texas decreased by 7% compared to 2013.

Comparing the irradiation in both locations, the graph revealed that average global solar irradiation in Austin was about 2 times higher than in the Netherlands.

Figure 4.10 shows that the higher global irradiation in Texas was mainly responsible for the higher electricity generation from solar photovoltaics by households in the Pecan Street.

Another factor that might have supported this higher generation capacity is the higher average installed power of distributed energy technologies such as solar photovoltaics in Pecan Street (8kw versus 5kw).

Regarding the influence of local temperatures on energy consumption and generation, Figure 4.11 shows the average ambient temperatures in the Netherlands and in Austin for 2013 and 2014.

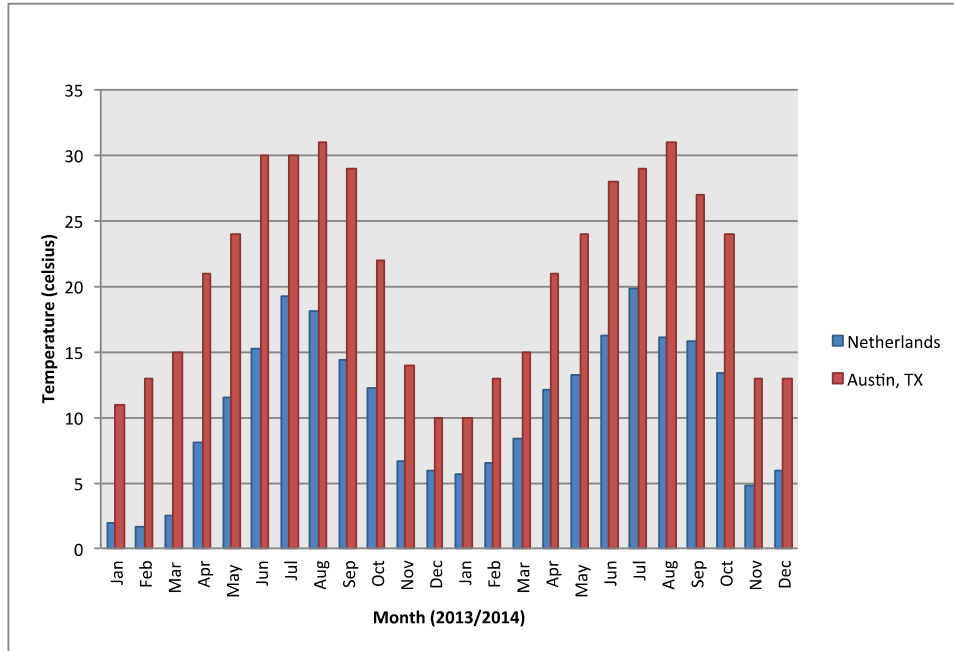

Figure 4.11. Mean monthly temperatures for the Netherlands and Austin (TX) in 2013/2014
 Source: (Western Regional Climate Center USA, 2016; EIA, 2016)

Figure 4.11 indicates that the average temperature in the Netherlands ranged between 2 to 20 °C in 2013 and 2014, while average temperatures in Austin were in the range of 10 °C to 31 °C. Comparing the temperatures in both locations, the graphs revealed that Austin is about 2 times warmer than the Netherlands.

A large difference in temperatures is also observed in the summer months (30 °C in Austin versus 17 °C in the Netherlands). With an average temperature of about 4.5 °C, the winter months in the Netherlands was 3 times colder than Austin, which recorded an average temperature of 12 °C in 2013 and 2014.

Figure 4.11 shows that average temperatures in Texas were quite high, while temperatures in the Netherlands could be described as being cold to moderate. Compared to other areas of the United States, the warmer weather in Texas means a higher use of air-conditioning units for cooling purposes. The use of air-conditioning systems accounts for a about 18% of electricity use, particularly during the summer months (Rhodes et al., 2014; EIA, 2016). Nearly 90% of new homes in Texas are built with central air conditioning. Air-conditioning units are also very common in single-family homes, such as those in this study. The questionnaire survey by Pecan Street Organization (Pecan Street, 2015) revealed that in 2013 and 2014, 70% of the households had split unit air-conditioning systems with installed in their homes. Most households (more than 50

percent) stated that the use of air-conditioning units have a significant impact on their energy use (50-90 percent of their energy usage). In addition to the use of air-conditioning units during the summer, most households have ceiling fans that are left on to maintain air-circulation.

Regarding occupational characteristics, the number and age of residents, and income influences the energy use. Large families, and households with young people are expected to use higher amounts of electricity to power electronic appliances such as computers, mobile telephones, video and computer games, and for laundry purposes (Biesiot and Noorman, 1999; Liao and Chang, 2002; Van der Linden, 2006; Nibud, 2016). Age of household members also influences the internal climate of homes. For instance, older people prefer warmer houses in contrast to younger people.

Compared to PowerMatching City, households in Pecan Street have a larger number of children under 18 living at home. This implies that the use of electronic appliances and air-conditioning will be more common in Pecan Street households. Single-family homes also have tendencies to use more energy than those living in social housing (Vringer et al., 2007). This can be attributed mainly to a higher income level.

With regards to the building characteristics, larger-sized houses would require more energy for heating and cooling purposes and lighting, compared to smaller houses. According to Entrop (2013) and Vringer (2005), the floor surface has a large influence on heating and cooling.

The houses in PowerMatching City and Pecan Street have similar characteristics, with participants living mainly in relatively new or retrofitted houses. A remarkable difference however is that the houses in Pecan Street have relatively larger square footage than those in PowerMatching City. While the floor area of households in PowerMatching City ranged between 100m² and slightly above 200m², households in Pecan Street had floor areas ranging between 1000m² and 4200m².

System characteristics involve the use of ventilation, heating and cooling systems to provide comfortable and healthy living spaces in households. According to Entrop (2013), household preferences to maintain a certain minimum indoor temperature also partly influence their energy use. Heating systems are used during the winter, while cooling systems are employed to provide more comfortable conditions during warm summer months.

While air-conditioning units are mainly employed in Austin, in the moderate Dutch climate, cooling systems are not often applied (Entrop, 2013). In the Netherlands, natural gas is mainly used in the winter for heating purposes and, households with heat pumps are most likely to employ these for heating purposes in the winter, and cooling in the summer, which rarely happens (Entrop, 2013).

The type of appliances, and how they are used largely influences the average electricity use in households. The usage behavior in relation to the use of lighting and household appliances could greatly impact energy use (Entrop, 2013).

Households with high income have more tendencies to acquire more electrical appliances than households with relatively low incomes (Entrop, 2013). High-income earners are also

more likely to pay lesser attention to tiny details of their energy use compared to those with lower incomes (Entrop, 2013; Nibud, 2016). In general, larger houses use more electric energy for lighting.

Participants in Pecan Street have more electronic devices such as computers, televisions, and lighting compared to households in PowerMatching City. A higher amount of electricity used for lighting, cooling, refrigeration, and for operating appliances, computers, and electronics is most likely in Pecan Street households. This is due to the prevailing energy usage behavior as reported by Pecan Street Organization (Pecan Street, 2015).

4.6 Discussion

In this section, we will reflect on the main research questions of this study: What insights can be gained from evaluating current residential smart grid projects from a user perspective, in particular with regards to the energy performance of products and services implemented in these projects? This study aimed to fill this gap related to little knowledge available regarding the participation of end-users in residential smart grid projects, and the energy performance of households in smart grid pilots with strong user involvement.

Comparing the design and set-up of the PowerMatching City smart grid project in Groningen (the Netherlands) and Pecan Street smart grid project in Austin (USA), it is observed that the way participants were involved in the pilots was quite similar. End-users in both projects also had similar characteristics such as high income and educational level, and motivation to participate in smart grid projects.

However, a difference was observed in the involvement of participating end-users in the development of the implemented products and services. While participants in PowerMatching City took part in the development of elements of the Home Energy Management Systems (HEMS), participants in Pecan Street mainly provided feedback to pre-determined HEMS tested in their homes.

With regards to the design of smart grids, as described before (see Chapter 2) a previous study by Geelen 2014 concluded that the design of smart grid projects, and the way end-users are involved could influence the adoption of implemented technologies, and household energy consumption. Therefore, the approach employed in the second phase of PowerMatching City, where end-users were more involved in product and service development, appeared to have supported a better interaction with the smart energy system, and a more active participation in their energy management.

In general, participating households in both projects consumed less energy than the average households in Austin and the Netherlands. The participation of the households in the projects appeared to have supported an increased awareness in energy utilization.

The energy performance, which is based on households' energy consumption and generation patterns, however revealed a large difference in the electricity consumption and generation patterns of households in the PowerMatching City and Pecan Street. In 2013 and 2014, the average electricity generated by households in Pecan Street was about 5 times higher compared to the generation in PowerMatching City. While the

summer months accounted for the highest electricity generation in both projects, the lowest energy generation occurred in the autumn and winter months. The higher solar irradiance and average installed power of distributed generating energy technologies, such as solar photovoltaics was the major influencing factor for the higher electricity generation in Pecan Street.

With regards to electricity consumption, average households in Pecan Street consumed 4 to 5 times more electricity compared to households in PowerMatching City in 2013 and 2014. While peak electricity consumption is observed in Pecan Street in the summer months, the winter months were responsible for the peak consumption in PowerMatching City. Higher average temperatures in Austin, and the usage of air-conditioning systems, appeared to have mainly influenced the electricity consumption patterns in Pecan Street.

Although mean temperatures in Austin and the Netherlands did not vary much between 2013 and 2014, the electricity consumption of households in PowerMatching City decreased. In contrast, the electricity consumption of households in Pecan Street increased. Also, while the amount of electricity households in PowerMatching took from the electricity grid decreased with increased generation from solar photovoltaics, grid consumption in Pecan Street increased with increased self-generation.

In our opinion, additional factors such as types and usage of appliances, and the way energy is used in households also partly influenced electricity consumption of households in both projects.

The energy performance analysis showed that households in PowerMatching City appeared to have a higher potential to contribute to demand and supply balancing in the electricity network compared to Pecan Street households. In general, they seemed to satisfy their own demand in times of high self-production with minimal reliance on the grid.

The energy performance of households in PowerMatching City also appeared to have improved with the improved products and services that supported a better interaction between the households and the smart energy system. This is evident in the reduced electricity consumption in 2014.

User experiences in both projects showed that a large percentage of participants in both pilots were not always capable of using the implemented technologies, such as smart programmable thermostats. This is mainly due to complexity in comprehension of feedback.

The correct setting of programmable thermostats by end-users could support a better regulation of smart appliances, and heating and cooling appliances. This also supports reduction of peak electricity demand, particularly in areas air-conditioning units are mainly deployed. Optimal use of these thermostats is therefore considered a determinant factor in household electricity use and energy efficiency (De Meester, 2013; Peffer et al., 2011). However, in order to increase the adoption of technologies such as thermostats, end-users should not perceive them as being difficult or cumbersome (Kobus et al., 2012). Another major insight from user experiences in both projects is related to the use of manual and automated technologies. End-users in both projects had preference for technologies that automatically shift their energy use. This is because these kinds of technologies require minimal effort to operate.

Insights from this study re-affirm findings from (EEA, 2013), that concluded that the interaction between end-users and new energy technologies still remains challenging.

It also highlights the existence of various end-user segments, and the need to better address these various segments in the development of new smart grid products and services as suggested by (Kobus et al., 2012; Geelen et al., 2013).

Although this study provides the most recent overview of user experiences and energy performance of two different smart grid pilots, some limitations have been identified. First is the limited number of households involved in our evaluation, which limits the generalizability of our findings. Second is the lack of equal data from PowerMatching City related to the usage of individual household appliances. Third is the fluctuating number of persons in the households and the missing data related to these fluctuations in the PowerMatching City database. This is the reason why the evaluation was only based on 21 households, instead of the 40 households participating in the pilot. This is in contrast to the 85 households evaluated in the Pecan Street project.

The averaging of the electricity generation and consumption data of the households in both projects definitely had some impact on the total average electricity consumption of the group of households evaluated in this study.

It would be expected that some households consume more electricity than the others based on the prevailing behavior, number and ages of occupants and the number of household appliances owned.

However, in a smart grid, but individual and collections of households in a neighborhood could have a huge influence on the overall balance between electricity demand and supply in a local smart grid.

An evaluation of the energy performance of individual households could reveal more details and variability regarding energy production and consumption per home.

Therefore, it is recommended that a more in-depth quantitative performance evaluation of households participating in residential smart grids projects be carried out. In this regard, data related to the performance of specific technologies implemented in these households should be analyzed. This will support the assessment of the efficiency and autonomy of these households at different times and periods of the year.

4.7 Conclusions

Two residential smart grid projects, PowerMatching City, Groningen (NL) and Pecan Street, Austin Texas (USA) have been compared regarding their energy performance and the experiences of users in these projects. The objective of the comparison was to gain new insights that could support the successful deployment of future residential smart grids.

Measured data on electricity generation and electricity consumption of households in 2013 and 2014 were evaluated. Existing reports with results of surveys of users were also analyzed.

The energy performance showed that households in PowerMatching City consumed an average of 2.6 GWh domestic electricity, which is 74% lower compared to the Pecan Street household average domestic electricity consumption of 10.1 GWh. At the same

time, households in Pecan Street generated about 6.8 GWh of electricity, which is 83% higher compared to 1.14 GWh generated in PowerMatching City.

Households in Pecan Street consumed on average, 8% less electricity with respect to the USA average household domestic electricity consumption of 10.9 GWh; while households in Pecan Street consumed 19% less with respect to the Dutch average household domestic electricity consumption of 3.1 GWh.

User experiences revealed that end-users in both projects were not always capable of using the implemented smart grid technologies. End-users in both projects preferred technologies that automatically shift their energy use, since this requires minimal effort from them.

In general, households in PowerMatching City appeared to have a higher potential to contribute to demand and supply balancing in the electricity network, because their electricity consumption from the grid was largely reduced with increased self-generation. Also, the energy performance of households in PowerMatching City appeared to have improved with the implementation of the smart grid technologies.

We conclude that the pattern of households' electricity generation and consumption in smart grid projects, and their contribution to peak load balancing in the electricity network is largely influenced by existing smart grid set-ups, especially with regards to products and service development (top-down versus bottom up approaches); local climate and related needs for heating and cooling, the average capacity of installed energy generating technologies and the prevailing energy behavior in the USA and the Netherlands.

Chapter 5 Preferred Attributes of home energy management products for smart grids: results of a design study and related user survey

This chapter is based on:

Obinna, U., Joore, P., Wauben, L. and Reinders, A. Preferred Attributes of Home Energy Management Products for Smart Grids – Results of a design study and related user survey. (Submitted 2016, under review)

5.1 Introduction

The previous chapters showed that the engagement of end-users is important for the successful development and deployment of smart grids. This is also the main reason why an increased attention is being paid to researching smart grids from a user perspective.

Chapter 4 mentioned that while certain products and services implemented in residential smart grid projects require some form of manual interaction in order to support end-users to be more active in their home energy management, user experiences revealed that end-users mainly preferred technologies that automatically shift their energy use. This is because products and services that supported automatic control of energy user require minimum effort from them. Chapter 4 concludes that interaction between end-users and new energy technologies still remains challenging, leading to increased resistance towards the acceptance of smart grids products. Chapter 4 also showed that the adaptation of smart grid related products and services is partly related to how they are designed and developed.

As concluded in chapter 2, a design-driven approach could support the development of new innovative smart grid products that facilitate a co-provider role for end-users in the future electricity system.

Therefore, this Chapter explores the role of Industrial Design Methods (IDMs) in the development of new innovative Smart Grid products known as Home Energy Products (HEMPs). These products support end-users in energy management in a smart grid.

In addition, the perceptions and preferences of end-users with regards to the features of existing and newly designed HEMPs for smart grids were evaluated.

This chapter is structured as follows: section 5.2 presents the background and objective of this study. Section 5.3 discusses the theoretical and methodological part of this research, including a description of the HEMPs evaluated in this study. Next, the results of the analysis of reports and meter readings that formed the basis of this study is presented in Section 5.4, followed by discussion and conclusions in Section 5.5.

5.2 Research background

The preceding chapters show that the transition to smart grids is expected to occur in the coming years. This development has resulted in the need to develop new innovative smart energy products and services at the household and residential areas (IEA, 2011; IEA, 2016). As a result of strong incentives of the EU and national governments worldwide, and the number of households per country, these markets are expected to be significant. However, it is difficult to give yet exact numbers for market volumes of smart grid energy products at this moment. These smart products and services stimulate a more active role for end-users in the management of their electricity system, by enabling them to have greater management ability over their energy consumption (Geelen et al., 2013).

For end-users to accept and adopt these smart energy products, design processes play an important role (Reinders et al., 2013; Kobus et al., 2012, Kobus et al., 2016). These studies state that a closer insight in energy technologies in relation to appropriately matched

design processes is necessary to better embed energy technologies in industrial product design, and therefore lead to more optimal products and services. In their opinion, better product design reduces complexity, and therefore increases acceptance and understanding by the end-users.

As stated in Chapter 1, the overall aim of design research is to enable the development of successful products and services, (Blessing and Chakrabarti, 2009). Specifically, design research aims to create value for end-users.

Therefore, in addition to technology development and market demand in smart grids products and services development, the incorporation of end-user expectations will be required to develop more acceptable products and services.

The development of new products is usually achieved through technological innovation. Industrial product designers play a strategic role in technological innovation and product development processes (Eggink and Reinders, 2013). Industrial Design Methods (IDMs) are also useful in product development processes. IDMs help to convert the needs of the end-users and market into detailed information for manufacturable products and services. In the context of industrial design engineering, innovation is made up of technology, design and styling, human factors, marketing and society (Reinders et al., 2012). Here, technology refers to product technologies and manufacturing processes. Design and styling relates to the appearance of products and their market image. Human factors refer to the user context or the functional design of products. Marketing is related mainly to market value costs and sales, and society refers to policies, regulations and societal acceptance. These five components of the so-called innovation flower (Figure 5.1) are considered essential components for product development and the final success of a product (Reinders et al., 2012).

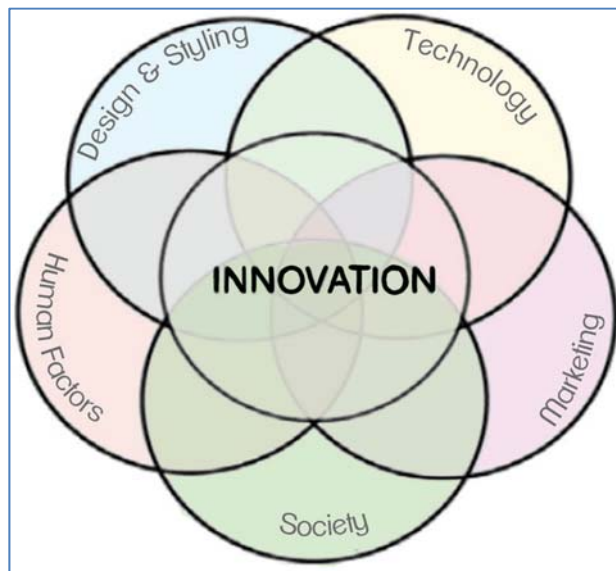

Figure 5.1. Innovation flower of industrial product design
Source: Reinders et al. (2012)

As stated in Chapter 2, various smart grid products and services currently exist, namely: micro-generators, storage systems, smart appliances, time variable prices and contracts, and energy monitoring and control systems also referred to as Home Energy Management Systems (HEMS) (Van Dam, 2010, 2012; Geelen et al., 2013). HEMS have been mainly described as various digital technology systems, communication platforms and sensors namely: smart meters, Home Area Networks (HAN) and home energy storage systems that provide energy management services in order to efficiently monitor and manage electricity generation, storage, and consumption in smart houses and smart grids (Son & Moon 2010; LaMarche et al., 2011; Han et al., 2011; Gungor 2011; Balta-ozkan et al., 2013; Zhou et al., 2016). HEMS are therefore mainly considered as infrastructure or essential home systems that improve energy efficiency, especially for electricity distribution systems and for successful demand-side management of smart grids by electricity grid operators.

However, this description of HEMS mainly refers to a range of very complex technical products that perform a technological task, for instance focused on energy storage or on balancing energy demand and supply at the electricity grid level. The functioning of these kinds of products is mostly invisible to household end-users, as end-users usually have limited or no interaction with these kinds of products (Geelen, 2014).

A study by Van Dam et al. 2010, however, described HEMS as “intermediary devices that can visualize, monitor and/or manage domestic gas and/or electricity consumption”; whose main purpose is to give users direct and accessible insight into their energy consumption (Van Dam et al., 2010 pp. 458-469). HEMS, therefore, play an important role in end-user interaction with other smart grid products and services such as micro-generators, storage systems, smart appliances, and time variable prices and contracts or dynamic pricing (Van Dam, 2012; Geelen et al., 2013).

HEMS can be divided into three groups of products namely:

- 1) user interfaces,
- 2) software platforms, and
- 3) smart hardware (Karlin et al., 2015).

User interfaces provide data about end-user electricity consumption in various forms, namely in the form of numbers, or graphs or other visualizations. Software platforms include smart home platforms, data analytics platforms, and web services platforms. They collectively facilitate the communication of information between users, utilities, and hardware in the home and provide end-users additional functionality for managing connected devices.

Smart hardware comprises of products such as smart appliances, thermostats, lighting, and plugs that physically enable household energy demand to be controlled such that the energy demand patterns of particular appliances are modified to meet household energy needs (Karlin et al., 2015).

Our study, therefore, focuses on smart hardware, and we will refer to them as “Home Energy Management Products” (HEMP), instead of more commonly used terms such as “Smart Grid Products” or “Home Energy Management Systems” that may include a broad range of separate elements that mainly function automatically in the background, with

limited or no interaction with end-users.

In this study, we define a HEMP as a product that is part of a HEMS, and which has an active interaction with the end-users.

As stated in Chapter 2, many HEMPs are already commercially available (Netherlands consumers' association, 2016). These range from single control devices, such as smart thermostats, lighting control with motion sensors, dimmers, remotes or scheduling; inventive thermostats; smart plugs; smart power strips that allow the end-users to actively control energy use, to centralized home automation systems. About 53 different smart energy products are currently available in the Netherlands (Netherlands Environmental Center, 2016). These include various smart thermostats such as Toon, Nest, Honeywell and Netatmo and electricity monitors such as BeeClear, Neurio and/or combined HEMPs such as Anna, Plugwise, i-care, Smappee, and Oxio's HEMS.

Though the effective application of HEMPs may support and stimulate energy-efficient behaviour and reduce energy consumption in households, HEMPs have often been criticized for their perceived complexity. This complexity results mainly from various hidden functionality and range of functions that tend to autonomously take decisions without considering the user context and needs (Van dam et al., 2012).

To ensure that end-users actively engage with products such as HEMPs, it is important for end-users to have control over the product instead of the product controlling the user (Van dam et al., 2012).

The perceived complexity of HEMPs could be reduced by designing more goal-based collaborative interfaces (Rich et al., 2001; Van dam et al., 2012). These kinds of interfaces support the user to learn more about the product and also have some level of control, instead of becoming totally dependent on an external wizard or agent (Rich et al., 2001; Van Dam et al. 2012). Figure 2 shows that goals can be communicated between the user and the product such that the product can help the user to meet a goal. The product agent as shown in Figure 5.2 could then play a more tutoring or supportive role instead of taking actions autonomously.

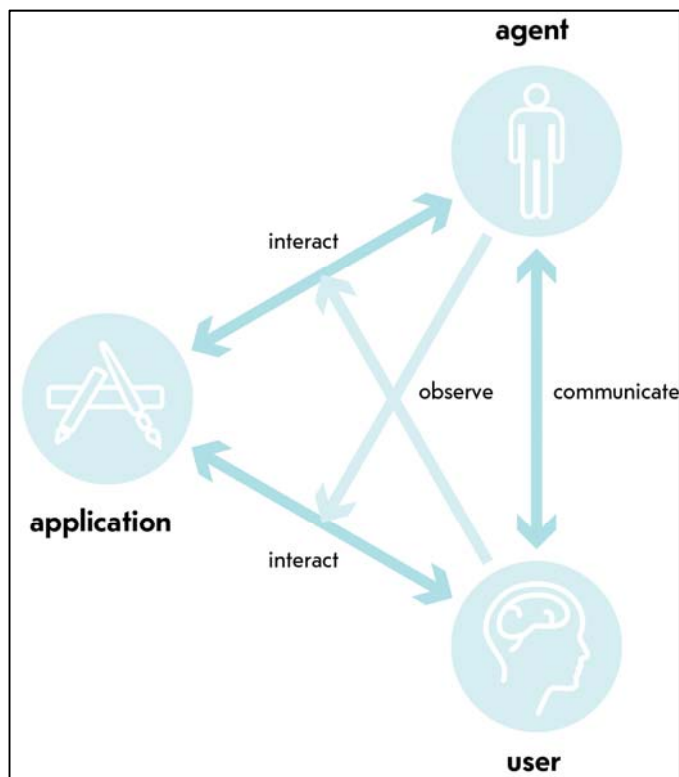

Figure 5.2. The collaborative paradigm
 Source: Rich, Sidner, and Lesh (2001)

In general, it is the expectation that HEMPs can contribute to 4% energy savings on the long run per household. However, the expected energy-efficiency potential of HEMPs is estimated to be in the range of 2% to 20% (LaMarche et al., 2011; Karlin et al., 2015). This is, however, an expectation by the developers of HEMPs. In practice, there is little evidence of the energy-efficiency stimulating influences of the use of HEMPs on the long run. Studies and reports on the subject of HEMPs have shown that they have not always stimulated energy-efficient behaviour as projected by the manufacturers (Van Dam, 2012; Netherlands consumer association, 2016). Even worse, rebound effects and an increase of energy consumption have been reported.

End-user adoption and effective use of HEMPs are being limited because of complexities in deployment, set-up and use, and the often too technical information presented (LaMarche et al., 2012). Previous studies have shown that current approaches in developing smart energy products and services has often resulted in technically complex products that are not always easily understood by end-users, and therefore do not effectively fulfil the needs and wishes of end-users (Geelen, 2014; Obinna et al., 2016). This could be partly attributed to the current method employed in developing smart energy products and services, which is mainly focused on technology development, and the limited attention paid to end-user behaviour and interaction with smart grid

technologies (Verbong et al., 2012). A study on stakeholders' involvement in residential Smart Grids development concluded that there should be more attention for end-user involvement; especially with regards to product and service development see Chapter 3 (Obinna et al., 2016). Smart energy products, such as HEMPs, can help to establish this end-user involvement, and that is the reason for which the research presented in this paper was carried out. As described in Chapter 3, we have shown (Obinna et al. (2016)) that the development of smart grid related products, such as HEMPs, have often been initiated by technically oriented organizations such as product and service suppliers and grid operators.

Studies by Reinders et al., 2012; Park 2014; Geelen et al., 2013 have concluded that end-user adaptation and acceptance of smart energy products and services will determine their effective functioning. In this regard, it is important to take the end-users' needs, wishes and abilities into consideration during the development and implementation of smart energy products and services such as HEMPs. Also, in order to properly develop and effectively spread new smart energy products for households, it is necessary to achieve a better understanding of the exact functionalities that would make end-users accept or reject these HEMPs. In addition, the relevance of good designs for effective man-machine interaction has been advocated by previous studies (such as Peslak 2005; Karray et al., 2008; Steen, 2012).

The field of study of human-machine interaction has however hardly paid attention to the design of HEMPs.

Besides this, knowledge about specific attributes or functionalities of the products that end-users interact with could further be explored. Also, as far as we could determine, only limited experience exist with research on newly designed HEMPs. For instance, in a project evaluation carried out in the experimental smart grid pilot project PowerMatching City in Groningen, a new design was established for the HEMP that was tested during the project (Powermatching City 2014; Geelen, 2014 see Chapter 4). This HEMP was not, however, commercially available and will not be commercially available in the future. The same can be said about user interfaces in the Your Energy Moment Smart Grid pilot project (phase 1) Zwolle, executed by energy company Enexis (Kobus et al., 2012). In this project the user interface design was changed multiple times. On the basis of the evaluations, the design was modified.

Our expectation is that the application of Industrial Design Engineering (IDE) methods in the development of new conceptual HEMPs, and evaluation of these newly designed HEMPs, alongside already existing commercial HEMPs, may help to determine to what extent new design features may influence end-users' perception of HEMPs. Therefore, the objective of this research is to explore the end-users' perceptions of and preferences for existing and new conceptual smart energy products, and the functionalities of these products that may best stimulate energy-efficient behaviour. The questions that we aim to answer are 1) How can design interventions support the development of new products in future smart grid households, 2) What are end-users' perceptions and preferences with regards to the features of existing and newly designed Home Energy Management Products for smart grids?

In order to answer the above research questions, a combination of design-based and quantitative research approaches were employed. Specifically, a student design project was executed to develop new conceptual HEMPs for households. Thereafter, an online

questionnaire survey was carried out to evaluate end-users' perceptions and preferences with regards to the features of existing and newly designed HEMPs for smart grids.

- 1) To explore the role of Industrial Design Methods for the development of smart energy products for households
- 2) To evaluate end-users' perceptions of and preferences for existing and new conceptual smart energy products, and the functionalities of these products that may best stimulate energy-efficient behaviour.

5.3 Research method

In order to answer the above research question, the following approach and research methods were chosen.

- 1) Development of new HEMPs
- 2) Selection of the existing and newly designed HEMPs to be analysed
- 3) Setting up of online questionnaire survey
- 4) Selection of respondents, sending out questionnaire
- 5) Data Collection and Analysis

1) Development of new HEMPs

The conceptual HEMPs used as the basis for this questionnaire study were designed during two students' design projects (2013 and 2014), at the faculty of Industrial Design Engineering, University of Twente (The Netherlands) in the framework of the course 'Sources of Innovation'.

This course positions product development in the context of the innovation flower and provides theory about innovation processes and useful tools for the design of innovative technology-based products related to emerging technologies, such as smart grids (Obinna et al., 2014). This course provides theory about innovation processes and useful tools for the design of innovative technology-based products related to emerging technologies, such as smart grids (Reinders et al., 2012). For detailed information about the design process of the conceptual smart grid products, see Reinders and Houten, 2006; Eggink et al., 2009; Reinders et al., 2011; Reinders, 2012; Eggink and Reinders 2013; Obinna et al., 2014.

Students involved in this project were asked to design innovative HEMPs that can be applied in or around smart grid households, and which stimulates energy efficient behaviour. The products are also expected to be aesthetically appealing to household end-users and at the same time, stimulate energy-efficient behavior in a durable, intuitively understandable and comfortable way.

To achieve this design task, various Industrial design Methods (IDMs) were applied. The purpose of applying these IDMs is to get insight in which methods are most suitable for designers in general, as we do not have specific numbers.

These methods include (Reinders et al., 2012):

- 1) Platform-Driven Product Development (PDPD),
- 2) Innovative Design and Styling (IDS),
- 3) Delft Innovation Model (DIM),
- 4) Theory of inventive problem solving (TRIZ (Russian acronym)),
- 5) Multilevel Design Model (MDM),
- 6) Constructive Technology Assessment (CTA),
- 7) Innovation Journey (IJ),
- 8) Technology RoadMapping (TRM),
- 9) Lead User study (LU),
- 10) Risk Diagnosing Methodology (RDM).

These methods are described in Table 5.1 below:

Table 5.1. Industrial Design Methods used in the students' design project

Industrial Design Method	Function
1.Platform-Driven Product Development (PDPD)	Defines a set of related products (product families) that can be developed and produced in a time- and cost-efficient manner (Halman, Hofer, and van Vuuren, 2003)
2.Innovative Design and Styling (IDS)	Refers to the appearance of products and their image in the market (Eggink and Reinders, 2013)
3.Delft Innovation Model (DIM)	Aims to optimally combine the intrinsic value of technology with opportunities in the market (Buijs, 2003)
4.Theory of inventive problem solving (TRIZ (Russian acronym))	A comprehensive method based on long-term patent research leading to certain basic rules governing problem solving in product development (Altshuller, 1996)
5.Multilevel Design Model (MDM)	Describes the mutual relationship between new products and societal change processes (Joore, 2010)
6.Constructive Technology Assessment (CTA)	Focuses on the improvement of the role of actors in innovation journeys and consumer acceptance of new products (Deuten et al., 1997)
7.Innovation Journey (IJ)	Refers to patterns followed in product development (Rip, 2010)
8.Technology RoadMapping (TRM)	Establishes correlation between identified market needs and trends with existing and emerging technologies for a specific industry sector (Souchkov, 2005)
9.) Lead User study (LU)	Provides useful information to product designers by evaluating those who are the first to face needs that will eventually affect a larger market (Von Hippel, 2005)
10.) Risk Diagnosing Methodology (RDM)	Aims to identify and evaluate technological, organizational, and business risk in product innovation (Keizer, Halman, and song, 2002)

The product development had to be supported by using the PDPD method and at least three other given IDMs. The IDMs were not consulted at the same time, but rather in a sequential order. The students were supported in this task with various weekly lectures on both methodological and technological aspects. These lectures were supported by a guest lecture on smart grids, which was the main subject of this design task. A Smart Grid expert from Stiftelsen Det Norske Veritas and Germanischer Lloyd (DNV GL), a global firm operating in the field of smart grids implementation in the Netherlands and elsewhere, delivered this lecture. Next the design task was executed for the case of the Netherlands. Also the information that supported them in their various tasks was obtained from mainly Dutch smart grid and energy stakeholders. Regarding the knowledge of existing smart energy products, supporting information was based on the current Dutch energy market.

The students worked in teams of two for a period of twenty weeks (September to November 2013), and September to November 2014). Theory was provided by the publication *The Power of Design: Product Innovation in Sustainable Energy Technologies* (Reinders et al., 2012).

The design project had a total workload of five European Credits. The design approach was based on a standard design process developed by Pahl and Beitz (Pahl and Beitz, 1984). This approach (Figure 5.3), which is widely used in design engineering, entails the following phases: clarification of the task, conceptual design, embodiment design and detail design. Optimization of the working principles of the product is carried out in the first three phases, while optimization of the final layout and form is done in the last three phases.

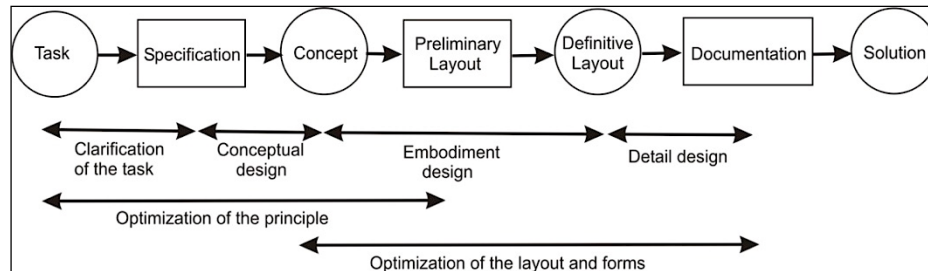

Figure 5.3. Flow chart representing the basic Industrial Design Method of Pahl and Beitz (1984).

The course was finalized with a presentation of the developed product concepts, a full report describing the design process, and the application of the underlying IDMs. The final product concepts were evaluated based on the use of at least four IDMs, elaboration up to technical drawings, explanation of the technical aspects and innovativeness of the product concept, rationale for choosing to design the product and the design tools used, the decisions made during product development, visualization through drawings, and the innovation trajectory and future market positioning.

2) Resulting concepts and selection of existing and newly designed HEMPs

The design projects in 2013 and 2014 yielded 41 various promising future product concepts that could be applied in future smart grid households. Figure 3 shows some of the developed product concepts. These included mainly HEMPs such as smart plugs, smart thermostats, in-home energy displays and various applications that are integrated with these products. In general, almost all the developed product concepts were aimed at providing a better insight into energy demand and supply in households, in order influence the behavior of end-users to increase energy efficiency in households and reduce peak electricity demand.

They include product concepts ranging from smart wall sockets, a smart energy meter, a smart energy planner, an innovative lighting device, smart plugs, an in-home energy display to a smart refrigerator, an electric vehicle charging station, a solar energy harvester, an innovative playground, smart energy storage devices, an innovative shower

concept and various applications that communicate with the smart meter. Table 5.2 shows some of the new conceptual smart grid products.

Table 5.2. Examples of innovative product concepts designed during the students design project

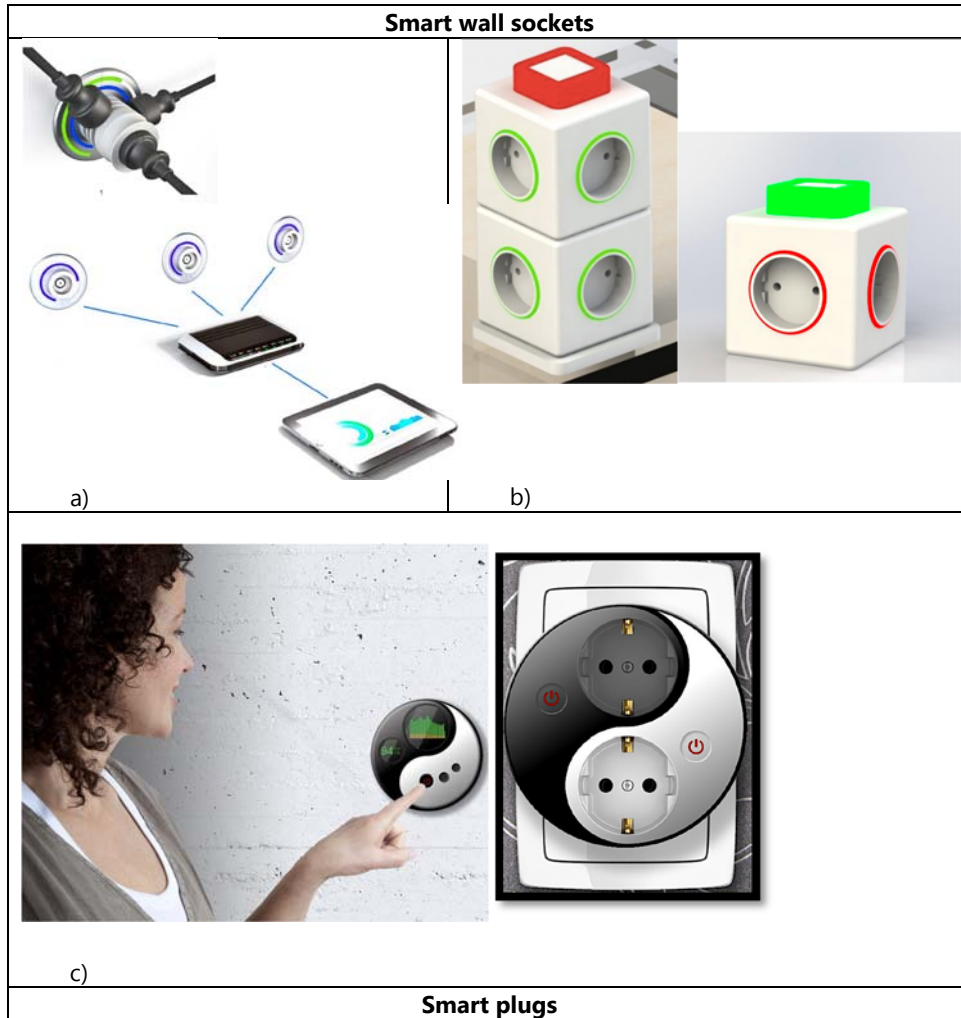

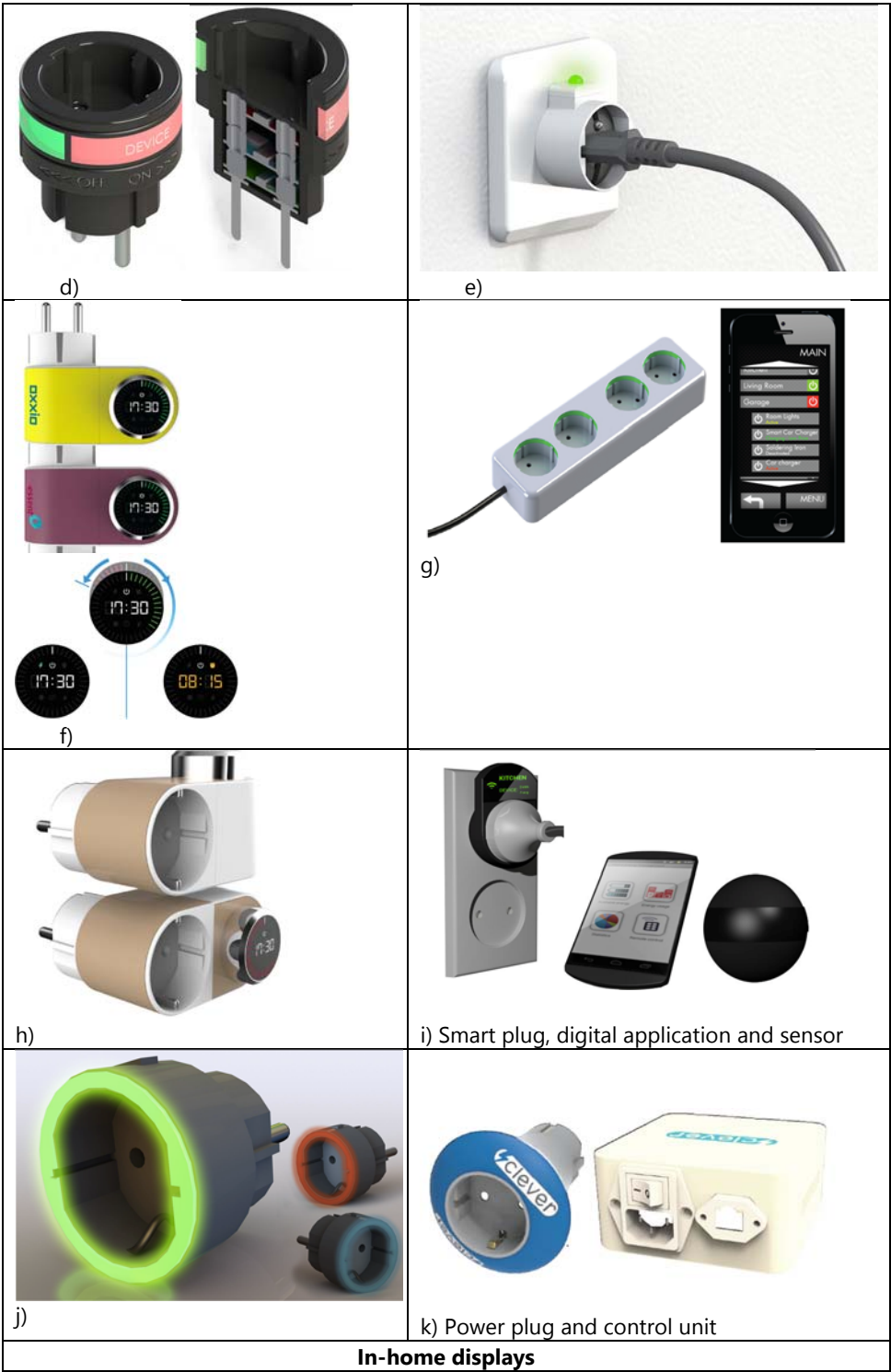

In-home displays

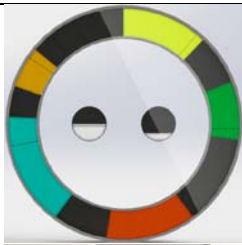

l)



m)

Smart thermostats



n)

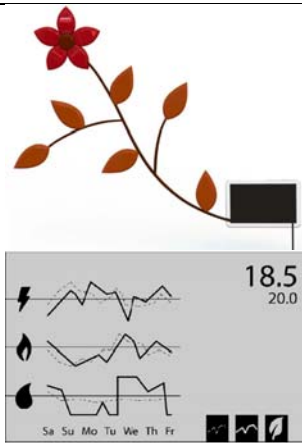

o)

Other categories

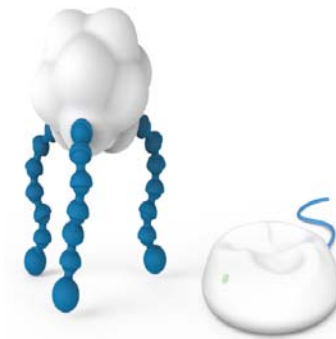

p) Electric lamp



q) Smart charging station

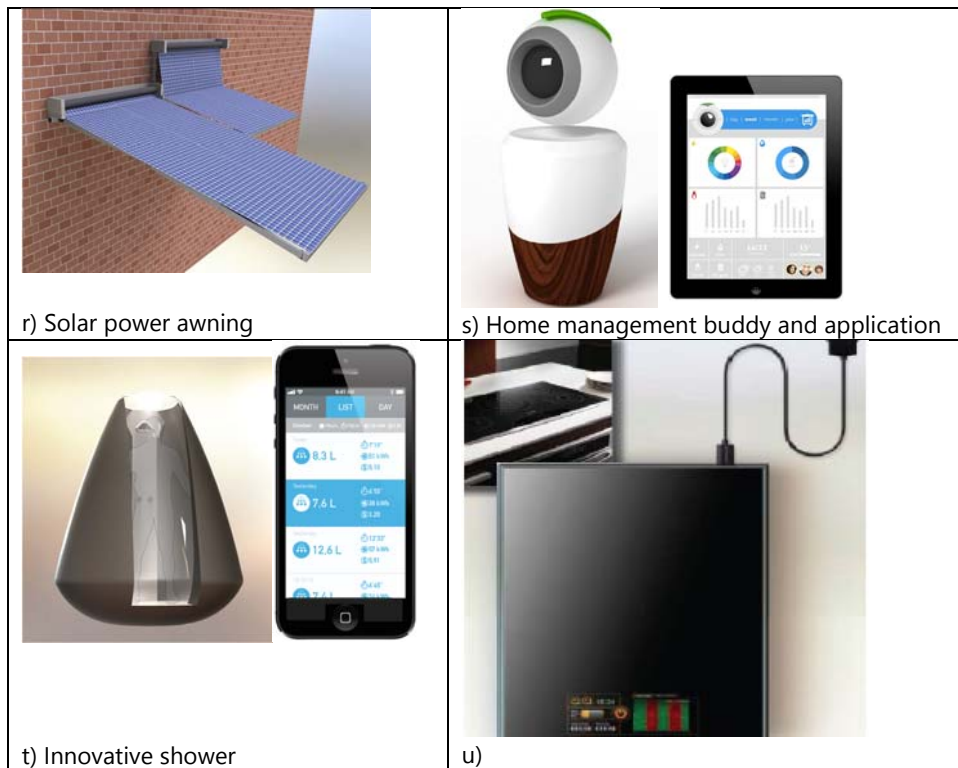

For our evaluation in this study, three categories of existing (commercially available) products and newly designed conceptual products were selected, namely:

- A. Smart wall sockets.
- B. Smart plugs,
- C. In-home displays
- D. Smart thermostats

These products were selected because they were the predominant categories developed in the design project, and also appear to be the major products existing in the current market of smart energy products. Focusing on product categories, instead of single products, helps to focus on the most important aspects of the product, instead of the specific characteristics that are of secondary importance (Bork et al., 2015). The specific products that have been selected were considered the most innovative, and most suitable for application in smart grid households. The product concepts selected for evaluation have been presented in the master reports of: Ten Brink et al., 2014; Young et al., 2014; Bergsma and Binnema, 2013.

In Table 5.3, the features of each type of product are shown. Each of the selected HEMPs gives insight into the entire energy use in households or energy use of specific household appliances. However, differences exist in their level of complexity and how they are used

(for example, manual versus automatic usage), and the type of energy information they provide. For instance, while a smart thermostat gives insight in the total thermal energy consumption of households, the smart plug and smart wall socket provide information about the electricity use of specific household appliances connected to them.

Although the three types of HEMPs evaluated in this study perform different functions, the main reason why these products were compared with each other is because they are control devices that enable households to manage their energy consumption, and collectively belong to the same category of HEMPs referred to as smart hardware (Karlin et al., 2015).

The most popular commercially available HEMPs in the Netherlands were selected. For instance, although there are many smart thermostats in the market, the Toon thermostat was selected instead of the Nest thermostat because based on a Google search, it appeared to be most frequently used among end-users in the Netherlands (Netherlands Consumer Association, 2016). We chose three brands of already existing and commercially available HEMPs namely: Toon smart thermostat from energy company Eneco, Fibaro wall socket, and Wemo insight smart wall socket.

The conceptual products (Table 5.4) were either new ideas or ideas adopted from already existing commercially available HEMPs.

iii.) Setting up online questionnaire

In this study a web-based questionnaire was used as the primary method of data collection. The rationale for using an online questionnaire is because our research question is aimed at gathering end-users' perceptions and preferences with regards to the features of existing and newly designed Home Energy Management Products (HEMPs) for households. Online questionnaires were considered the most suitable method to solicit this information since it creates the best opportunity to access a large and geographically distributed population that possessed HEMPs. In addition, online questionnaires provide the highest level of convenience for the respondents as they could fill out the questionnaire at their own pace, chosen time, and preferences.

Furthermore, this method makes it possible to have anonymous responses which allows respondents to answer with more candid and valid, honest and unambiguous answers. It is also considered easy to use for participants, and users have enough time to consider their responses.

For the questionnaire, the selected products were presented including a brief description of the product, highlighting the major functions these product concepts are expected to perform in Dutch households. Table 5.3 shows the already existing HEMPs, including a brief description of their features and attributes. Table 5.4 shows the conceptual HEMPs developed by the students.

Table 5.3. Existing commercial HEMPs

Products	Features/attributes
<p>Product A. Smart thermostat</p> 	<ul style="list-style-type: none"> i. Gives insight in thermal energy use, generation, and energy costs of household appliances ii. Connected appliances could be switched on and off from a distance with a smart









	<ul style="list-style-type: none"> iii. phone iii. Displays the energy use in households and the average use in the neighbourhood
<p>Product B. Smart plug</p>  	<ul style="list-style-type: none"> i. Gives insight in energy use and costs of household appliances ii. Possesses illuminating LED-rings that changes colour based on the energy consumption. The light flashes when the maximum load (2,5 kW) is exceeded iii. Connected appliances could be switched on and off from a distance with a smart phone
<p>Product C. Smart wall socket</p>   	<ul style="list-style-type: none"> i. Remote control on a smart phone ii. Possibility to set timetables for setting the smart plug on and off iii. Measures the power consumption of connected devices

Table 5.4. Conceptual HEMPs

Concepts	Features/attributes
<p>Product A. Smart thermostat</p>  	<ul style="list-style-type: none"> i. Displays feedback on energy use (water gas use; history of energy use and cost savings in Wh, €/hr; energy usage of other households via a manually controlled projector ii. Wireless communication module that provides communication between the device and appliances or control devices iii. Battery/transformer module for power supply controlled through applications on mobile devices

<p>Product B. Smart plug</p> 	<ul style="list-style-type: none"> i. Communicate with a user interface e.g. smart phone application with a wireless module to display energy information ii. Provides information about energy availability, prices using colour indicators (Green: energy abundance/cheap price, Blue: equal demand and supply/standard price, Red: scarcity/high price) iii. An energy unit monitors energy consumption of devices iv. Manually switched on and off by the user
<p>Product C. Smart wall socket</p> 	<ul style="list-style-type: none"> i. Provides information about current energy situation and prices through LED indicators (green light= lower energy prices, red light=higher energy prices) ii. Contains replaceable batteries that store energy during off peak hours iii. Possibility to stack devices on top of each other to increase storage capacity iv. Mobile energy and remote use: device can be carried around

The questionnaire consisted of 22 questions, both open and closed-ended questions, and were related to the following topics:

1. characteristics of respondents (i.e. gender, age, household composition, educational level, type of houses respondents live in)
2. ownership of smart energy products, and types of smart energy products owned
3. preferences for existing and conceptual smart energy products and reasons for the preferences
4. features found most attractive in the chosen products and concepts, and other features desired

5. product concept consider to stimulate best energy efficiency
6. Likelihood of acquiring their chosen products or concepts, and remarks, ideas, and suggestions related to smart energy products

These questions were selected because they cover the most important issues related to the evaluation of end-user perception of the attributes of Home Energy Management Products that could make them more engaged with their energy at home.

iv.) Selection of respondents, sending out questionnaire

The target group for the questionnaire was a broad range of end-users, comprising of those early adopters that already have an interest in sustainable energy and those who do not. This approach was used in order to have a high response rate, and also to elicit the views of people who already know about HEMPs and those that do not know.

The questionnaires were distributed through various outlets in the Netherlands namely:

- a) people that are contained in the database of the Renewable Resources Research Group of the NHL University of Applied Sciences Leeuwarden, The Netherlands. The group focuses on the development and translation of knowledge in the field of renewable energy and technology into economic activities,
- b) stakeholders in the mailing list of the sustainable innovations programme of the provincial government of Friesland. The programme focuses on various innovation projects in the area of energy and the environment. The distributed it through their mailing list
- c) stakeholders in the mailing list of the municipal government of Leeuwarden. Also, the Facebook page of households involved in the " Smart Living in Leeuwarden Project" was used as a channel to distribute the questionnaires. This project supports households to implement energy efficient measures in their homes and install renewable energy technologies such as solar panels
- d) the energy and environmental coordinators of the municipality of Leeuwarden helped to distribute the questionnaires to people in their network
- e) the entire NHL mailing list managed by the marketing department
- f) contacts at the University of Twente, where one of the co-authors work

In general, the questionnaire survey was distributed to more than 1000 end-users.

In order to ensure that a substantial number of people filled out the questionnaires, a 50-euro tourist receipt was offered to the respondents.

v.) Data Collection and Analysis

The online questionnaire was circulated between June and September 2016 via qualtrics research suite survey software resulting in 87 respondents.

Qualtrics software programme performed the analysis of the questionnaire results. However, in order to ensure that the analysis performed by the Qualtrics software was accurate, the data gathered from the questionnaire survey were also transcribed in an excel worksheet, where new tables and graphs were generated. The various answers and comments given by the respondents were also transcribed in the excel worksheet.

5.4 Results

A) Application of Industrial Design methods

At the beginning of both projects, 10 IDMs were provided for the design of an innovative product concept that could be applied in smart grid households. This study revealed that in 2013, besides the use of PDPD (compulsory method), the methods TRIZ (n=12), DIM (n=11), IDS (n=9), and TRM (n=8) were mainly applied in the development of the product concepts. In 2014, in addition to the use of PDPD, the methods DIM (n=15), TRM (n=14), TRIZ (n=11), and CTA (n=8) were mainly applied in the development of the product concepts.

The results therefore show that four IDMs (PDPD, DIM, TRIZ, and TRM) were mainly used in designing the product concepts. These four IDMs, and their functions based on some product concept examples are presented below.

i) Delft Innovation Method (DIM)

DIM aims to combine internal strengths of technology with external opportunities in the market (Buijs, 2003). The method is made up of four phases: a strategy formulation stage, a design brief phase, a product development phase, and a product launch and use phase. The students in the start-up of the design process mostly used the strategy formulation and the design brief phases of DIM to define search areas related to smart grid technology and to discover opportunities in the market of smart energy products. An external and internal analysis is performed during the strategy formulation stage. External analysis includes an analysis of competitive products, needs, and external trends and developments in emerging technologies. The internal analysis shows the value of a brand and its strengths and weaknesses.

For instance, in the development of a smart plug (Table 5.1g), one of the design teams carried out an external analysis of existing HEMS. These HEMS were ranked on two aspects, namely whether they are simple or extensive and whether they inform the user or control devices. These aspects are shown on respectively the y- and x-axis. The systems were then placed in the overview.

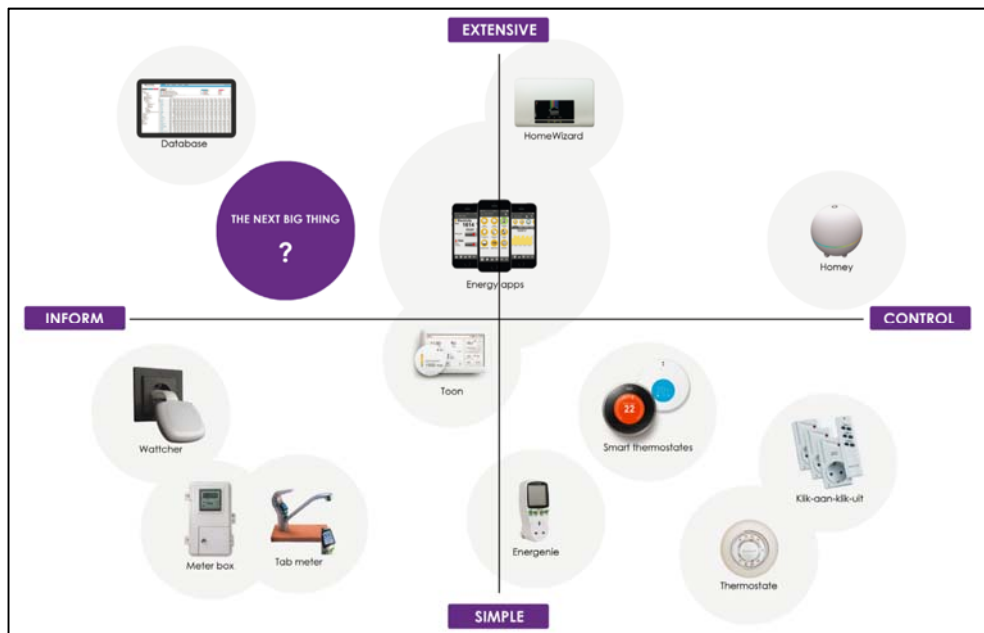

Figure 5.4. External analysis of HEMS
 Source: Rutgers and van den Belt, 2014

Figure 5.4 shows that a standard thermostat is mainly used to control appliances such as heating devices. It is a very simple product, which does not involve a lot of data or functions. As it only provides minimal information to the user, it is placed in the lower right corner.

A database, on the other hand, has as a main function to inform the user, and does not autonomously control devices. To inform the user, it contains a lot of extensive information. Although a database is not really a product, it is considered in this scheme, since it also indicates that a real product is missing in the upper left corner and even in the entire upper left quadrant.

From this external analysis, the conclusion can be drawn that a product that mainly informs the user about energy consumption, but still allows some level of control on different devices is needed. In order to perform this function well, extensive information is needed, but it also has to be simple enough for the average user. This way, extensive and maybe complicated information can be transferred to the user in a user-friendly way, supporting the user to be more aware of his energy consumption.

The use of DIM therefore provided the platform to generate search areas for new innovative products that could be used in smart grid households.

ii) Technology Roadmapping (TRM)

When designing new products, there are many uncertainties that need to be explored before a product can become a success. Knowledge of the market and the current and future states of technological possibilities are among these. TRM establishes correlation

between identified market needs and trends with existing and emerging technologies for a specific industry sector, to improve existing products and develop new ones. It is a list of milestones and contexts that highlight the requirements for past, current and future products. The framework is shown in Figure 5.5.

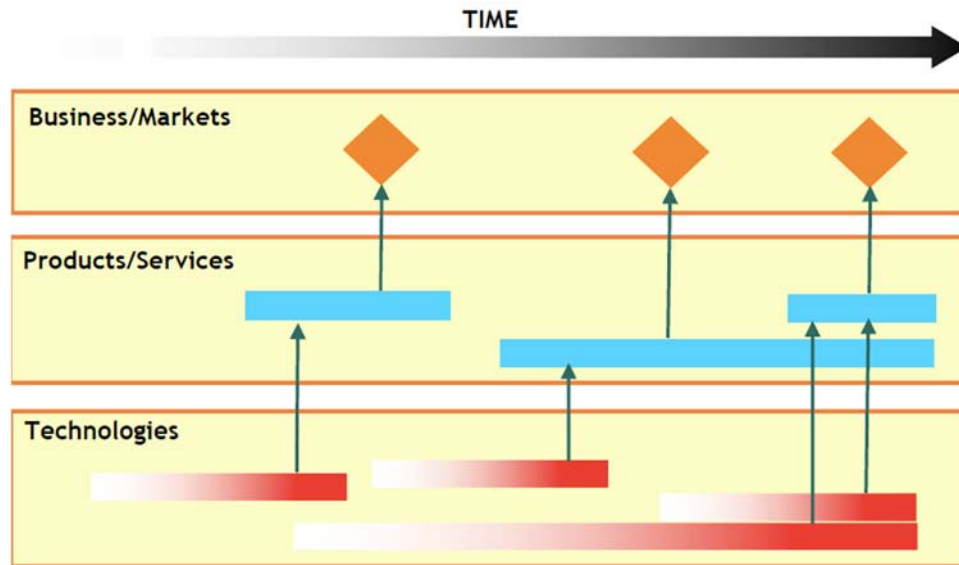
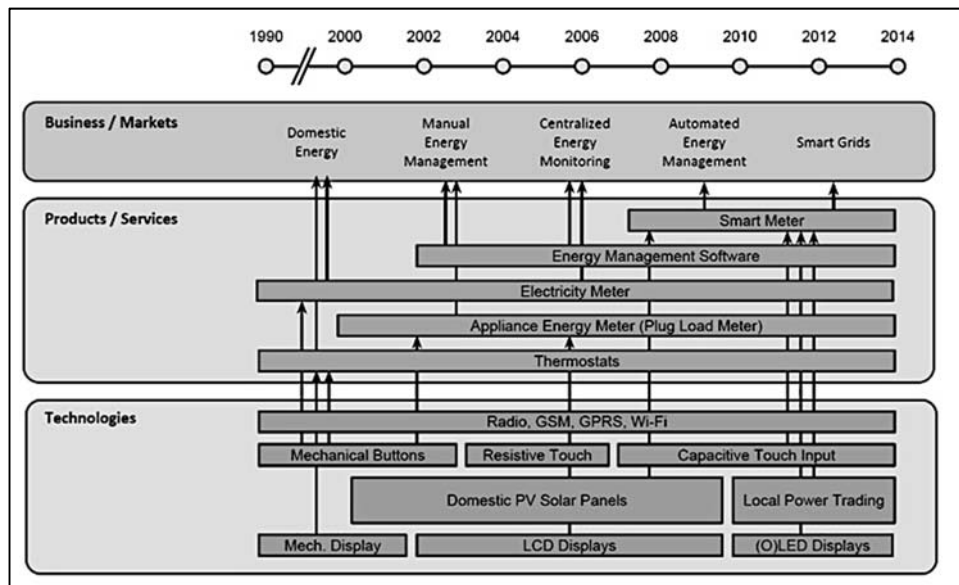

Figure 5.5. Framework of Technology Roadmapping
Source: Reinders et al. 2012

In the design project, TRM was mainly applied in the embodiment design phase to assess how various Smart Grid technologies will develop in the near future. It helped to create product features that are based on predicted technological maturity and market demand in relation to Smart Grids. For example, a student group that developed the smart thermostat (Table 5.1o) used TRM to explore the innovation trajectory of enabling technologies such as domestic energy products and recent Smart Grid technologies, shown in Figure 5.6.



LCD: Liquid Crystal Display
 OLED: Organic light emitting diode
 Mech. Display: Mechanical display
 PV: photovoltaic

Figure 5.6. Subcategories within the 'Enabling Technology' categories
 Source: Lamarche et. al., 2016

The exploration indicated that innovation could be achieved by extrapolating mentioned technologies to form potential product compositions. The roadmap consists of a timeline, with three categories – Business / markets, products/ services and technologies, each category being a result of the next one respectively. The diagram covers about 20 years of development, as the electricity meter and thermostats (both consisting of mature technologies today) can be considered the first stages leading into the smart meter used today by households. The conclusion can be drawn that no emergent technologies have led up to the development of the smart meter, except for 'local power trading', which has been rising slowly recently. This technology was considered as a direction of opportunity, and incorporated in the new product design. The other technologies appeared less important for this purpose, but were accounted for to add to a sufficient adequacy of the new product idea.

By analyzing technologies that have led up to recent products such as the 'smart meter,' innovation was achieved by extrapolating mentioned technologies to form potential product compositions.

TRM was mainly used to define prospects for selected search areas, and served as an interesting tool to extrapolate future developments in the area of smart energy products, from changes in technologies up to future market developments.

iii) Platform-driven product development (PDPD)

PDPD is a tool used to develop modular products. It can increase variety, accelerate

development and reduce complexity in product development. This helps to speed up development of new products, since it takes less time to build up a new product out of existing blocks, than to design it from scratch. For this project, PDPD was the compulsory method used by all student groups. It supported the development of product families and increased the modularity of the products.

For instance, in developing a smart plug that enables automatic and smart charging behavior for mobile devices (Table 5.1d), PDPD helped to combine several product platforms. The components include:

- Power Adapter components (coils, regulators, resistors, capacitors, diodes)
- System on a Chip micro-controllers (Central processing unit, Random Access Memory, and Read-Only Memory in 1 package)
- Near field Communications (NFC) controllers
- USB controllers
- Wi-Fi controllers and Antennae
- NFC transceiver chips
- Wireless Power (possibly in the future)

These components form the backbone to the internal modularity of the smart plug (Table 5.1d). Using PDPD, the general idea of the smart plug was broken up into different components, modules and platforms. These platforms were combined using interfaces to form architectures for different variations of potential smart plugs.

By standardizing the enabling technologies – such as sensors and display modules – multiple product families can be created at a low cost. Also, this allows for low cost maintenance, as standard modules are often mass-produced, thus allowing for replacement of these modules in case of failure.

In general, PDPD was mainly used by the students because of the emphasis of this project on incorporating sustainability in the development of the product concepts. In all design tasks undertaken in this project, PDPD was used to divide the functional concepts of the products into different modules that could be applied on other product platforms. PDPD was mostly applied during the concept development stage, to design modular products, consisting of several standardized components. It was used in all the design projects to generate a base (or platform) for future product generations– as newer technologies are made compatible with the platform. This way the product can be produced more cost-efficiently, the time to market can be reduced and it will be easier and more cost-efficient to create different product families for different market segments.

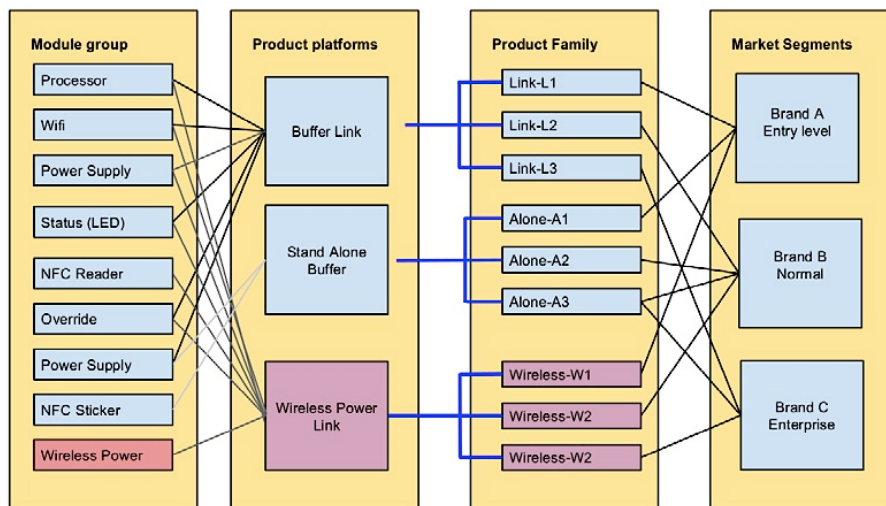

Figure 5.7. Product platforms for the smart plug shown in Table 5.1d
 Source: Findeisen and Haanstra, 2013.

iv) TRIZ

Theory of Inventive Problem Solving (TRIZ) TRIZ is a Russian acronym that means “the theory of inventive problem solving” (Alstuller, 1996). TRIZ includes several methods that support various stages of the idea generation process. It solves seemingly contradictions, and by doing so, contributes to product innovation. TRIZ tends to offer real problem solving. This is achieved by the use of 40 inventive principles that are the result of analyzing a huge database of pre-solved problems and structuring its solutions. The theory consists of a systematic step-by-step approach (Figure 5.8).

The majority of TRIZ principles were used in the later part of the ideation stage into the early concept development stage, after most of the product requirements have been established.

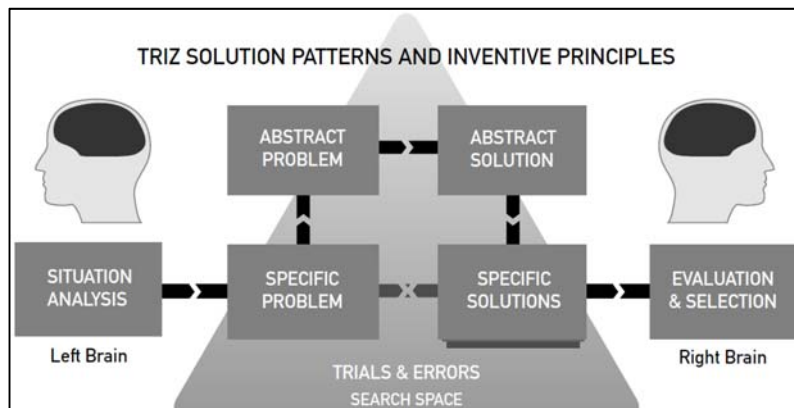

Figure 5.8. Problem solving with TRIZ

Source: Alstuller, 1996

The students mostly used TRIZ in the concept development phase, to identify problems

and contradictions within the design.

For example, in designing a smart plug (Table 5.1e), a group found out that their product concept required a large amount of electricity to function, whilst the goal of the product is reducing energy use in households. TRIZ supported the redesign of the product to one that uses electricity periodically (when needed), instead of continuously. Another example is the development of a product that will provide end-users insight and interface feedback to run appliances (Table 5.1q). Here, through the use of TRIZ, it was realized that providing too much information would lead to confusion for end-users. It also implies that more time and effort will be required to understand the given information, which could result in missing of relevant information. The solution lied in developing the interface in such a way that it provides feedback that is easily understandable by the user. This gave rise to the idea of incorporating a graph and pictograms/icons, and different levels of complexity, which supports the switch from a simple "normal setting" to a more complex "advanced setting". The application of TRIZ helped the students to make crucial and innovative design decisions that formed the basis for the rest of the product development process.

B) Survey Respondents' characteristics

In total, 87 respondents filled out the questionnaire survey. We consider this a high response rate given that not many people are familiar with these kinds of products.

The result shows that 72% of the respondents were male, while 28% were female.

The majority of the respondents (54%) were 46 years and older, 24% were between the ages of 20 and 35, while 22% were between 36 and 45 years of age.

Most of the respondents (34%) lived in households made up of 4 persons, 30% lived in households composed of 2 persons, while 18% had 3 persons living in their household. Most respondents (45%) lived in detached houses. This is almost three times as much compared to the average percentage in the Netherlands living in a detached house, which is 16.4% (OECD, 2014). 33% of the respondents lived in semi-detached houses.

Regarding their educational status, the result shows that 62% of the respondents possess a master's degree or a higher qualification, while 33% have a bachelor's degree. Together this means that 95% of the respondents had a higher education level, which is more than double the percentage of the average Dutch population, of which only 45% has a higher education (OECD, 2014). All in all this indicates that a relatively high amount of respondents are – compared to the average Dutch household - somewhat older, highly educated, male respondents living with their family in a detached house, which should be taken into account when reflecting on the results of the study.

C) Possession of HEMPs

While 35 respondents stated that they had one or more types of HEMPs installed in their homes, 39 had no HEMP in their homes. The remaining 13 respondents had no idea if they owned a HEMP.

The HEMPs that were owned included mainly smart meters (n=8), smart thermostats such as Toon and Anna brands (n=7), energy monitoring systems such as 'icare' from

Energq, Plugwise and Smappee (n=7), energy-efficient lighting systems (n=5), and smart appliances such as washing machines and dryers (n=3). Five respondents had solar panels and heat pumps installed in their homes.

Of the 39 respondents that did not own a HEMP, 14 stated that they are not familiar with these kind of products, 14 stated that they do not yet see the urgency of acquiring these products, 6 had no interest in these kind of products, 3 respondents said they saw little financial gains associated with acquiring these products and 2 found them too expensive.

D) Evaluation of existing HEMPs

i) Attractiveness of the (existing and conceptual) products

Figure 5.9 shows how the respondents evaluated the attractiveness of the existing HEMPs. When being asked how attractive the presented existing three HEMPs were, the smart thermostat was generally rated the most attractive by the respondents compared to the smart plug and the smart wall socket.

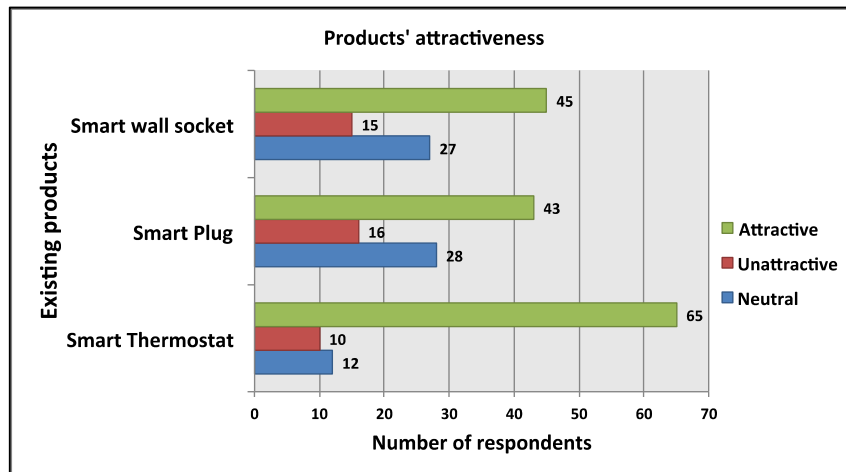

Figure 5.9. Attractiveness of the evaluated existing commercial available HEMPs

Figure 5.10 shows how the respondents evaluated the attractiveness of the product concepts. With regards to the respondents' opinion about the three conceptual HEMPs, the smart thermostat was generally considered the most attractive HEMPs.

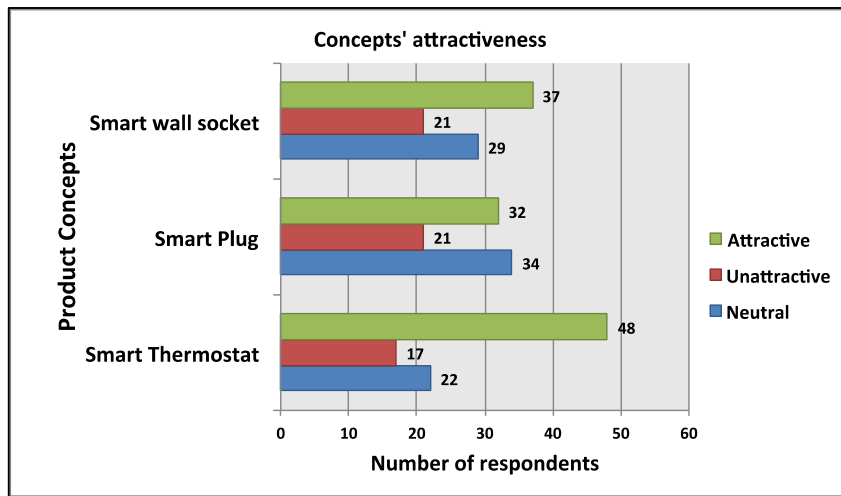

Figure 5.10. Attractiveness of the evaluated conceptual products

ii) Selection of favourite (existing and conceptual) HEMPs

When being asked which existing HEMP they would select, if they had to choose between them, 60 respondents considered the smart thermostat to be their favourite product, whereas 15 respondents preferred the smart wall socket, and the remaining 12 respondents selected the smart plug as their favourite product (Figure 5.11).

From the 39 respondents that did not possess a HEMP, 33 chose the smart thermostat as their favourite HEMP, 3 respondents respectively chose the smart plug and smart wall socket.

Out of the 13 respondents that had no idea if they possessed a HEMP, 10 stated that the smart thermostat was their favourite product. The remaining 3 had preference for the smart wall socket.

From the 35 respondents that owned HEMPs, 17 respondents had preference for the smart thermostat, 9 respondents preferred the smart plugs and another 9 respondents preferred the smart wall socket.

With regards to the three conceptual HEMPs, 40 respondents stated that the smart thermostat was their favourite concept, 21 respondents preferred the smart wall socket, while 16 respondents considered the smart plug to be their favourite concept (Figure 5.12). 10 respondents had neutral opinions about the evaluated product concepts.

Similar to the existing products, almost all respondents that did not possess a smart energy product chose the conceptual smart thermostat as their favourite product.

From the 35 respondents that owned smart energy products, 11 had preference for the smart thermostat, 10 respondents preferred the smart plugs, while 7 respondents preferred the smart wall socket. The remaining 7 respondents had no preference for the conceptual products.

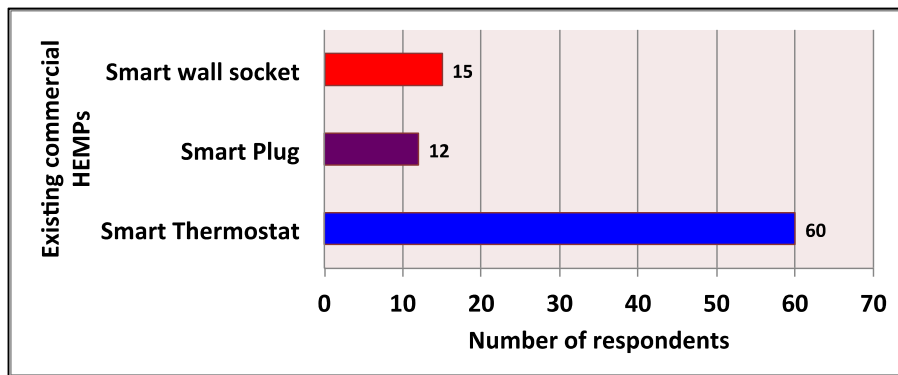

Figure 5.11. Preferences for the evaluated existing commercial available HEMPs

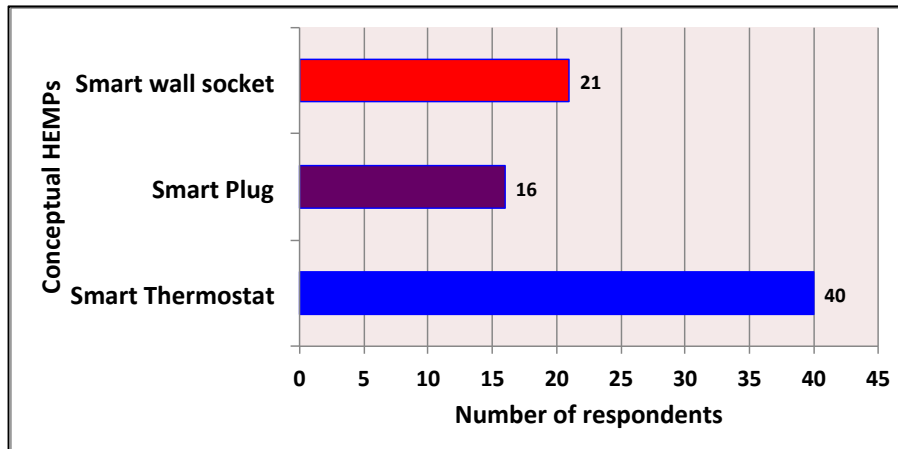

Figure 5.12. Preferences for the evaluated conceptual HEMPs

iii) Buying preference

When being asked if they would actually buy their chosen existing commercial HEMP, 64 respondents stated that they would like to acquire it, while 23 said they had no interest in acquiring their chosen products.

With regards to the chosen conceptual HEMPs, 50 respondents stated that there is a possibility of acquiring their chosen product. 17 respondents had no interest in acquiring their chosen products, while 20 were neutral.

iv) Relevant features for selecting a product

Figure 5.13 shows the features of the smart thermostat most preferred by the respondents. When being asked what made them choose a certain existing product as

their favourite, 28 respondents liked the smart thermostat features that support the monitoring of energy use of individual household appliances. 14 preferred features that enabled them to compare their energy usage with other households. 24 considered expected ease of use as an important feature, while 27 were attracted to the remote control features. 36 respondents found the visual display of energy information the most important feature that influenced them in choosing the smart thermostat, 4 based their choices on manual control features, while 6 were attracted by the physical appearance of the smart thermostat.

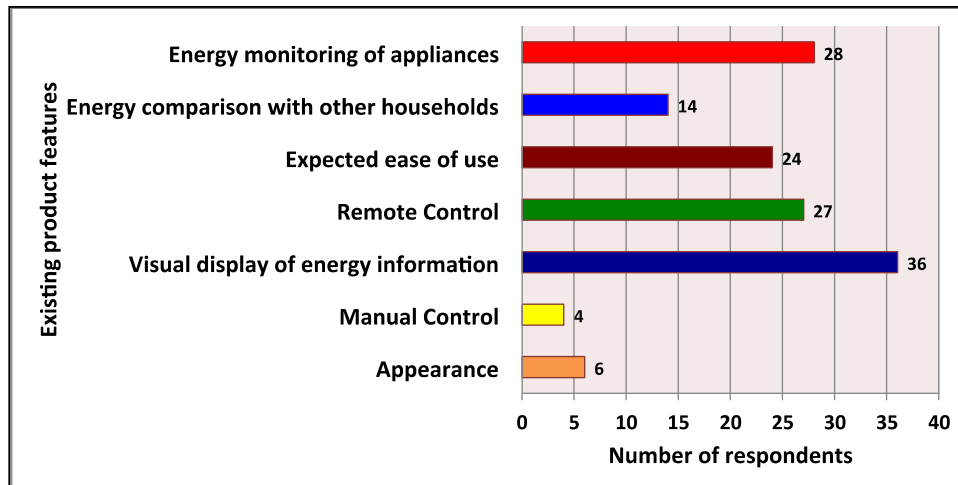

Figure 5.13. Existing thermostat preferred features

Figure 5.14 shows the features of the conceptual smart thermostat most preferred by the respondents. With regards to the newly designed concepts, 20 respondents preferred the features that support the monitoring of various household appliances. 10 considered ability to compare their energy use with other households as the most important features that made them choose the conceptual smart thermostat. 17 respondents were attracted to the conceptual smart thermostat due to expected ease of use, while 10 respondents liked the remote control features the most. 21 respondents stated that visual display of energy information was the most appealing feature that influenced their interest in the conceptual smart thermostat.

3 respondents based their choices on the ability to manually control the smart thermostat while 7 were attracted by the physical appearance of the smart thermostat.

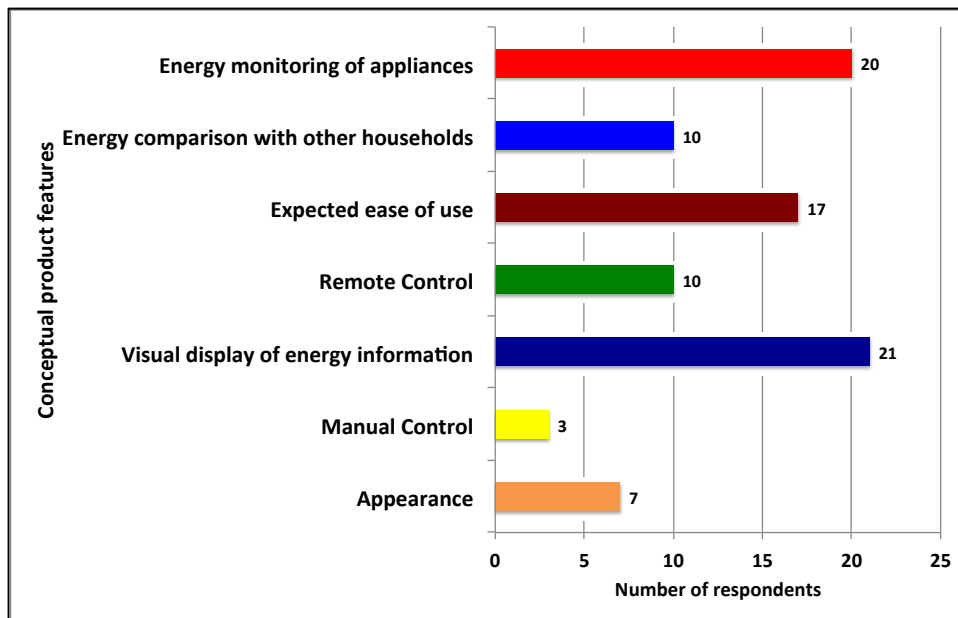

Figure 5.14. Conceptual thermostat preferred features

Visual display of energy information and remote control features were also considered important features that influenced end-users' choice of the conceptual HEMPs. However, for the respondents that chose the conceptual smart plug, appearance was considered a very important feature that influenced their choice (n=10).

Figure 5.15 shows the features most preferred in the existing smart energy products. In general, for the three evaluated existing commercial HEMPs, visual display of energy information was considered as the most important feature desired in these products. 45 respondents chose this feature as the influencing factor in their choice of the smart energy products. Monitoring of the energy use of individual household appliances appeared to be another feature desired in smart energy products, with 39 respondents liking this feature. 36 respondents were attracted to the remote control features of existing smart energy products, while 33 considered ease of use as an important criteria. 16 respondents preferred features that enabled them to compare their energy usage with other households. Physical appearance features attracted 10 respondents, while 9 based their choices on the ability of their chosen concepts to be manually controlled.

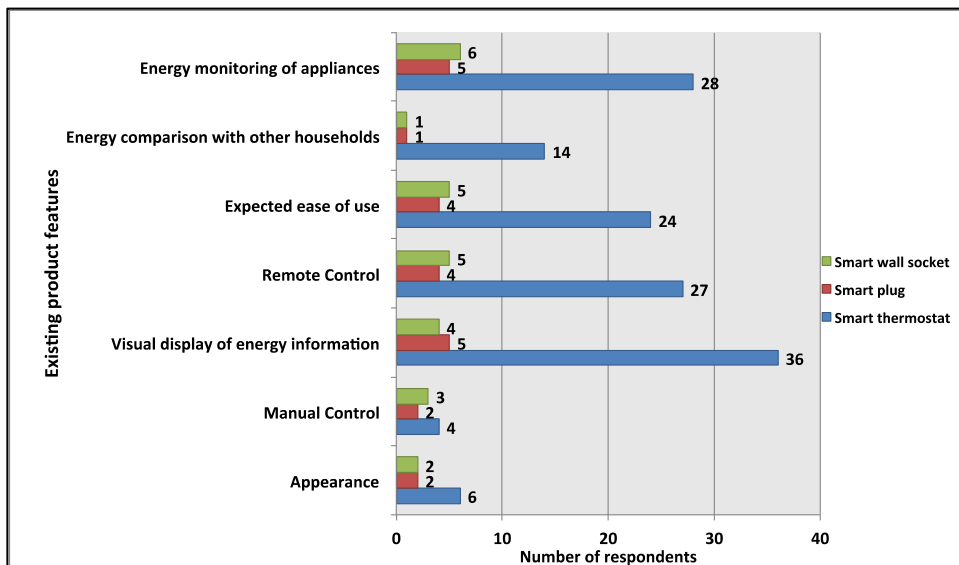

Figure 5.15. Features most preferred in the existing smart energy products

Figure 5.16 shows the features most preferred in the conceptual HEMPs. In general, for the three conceptual HEMPs, 31 respondents considered visual display of energy information as the most appealing feature that influenced their choice. 30 respondents chose the new concepts because they possess features that support the monitoring of various household appliances. 25 respondents were attracted by the expected ease of use of the newly designed smart energy product. 14 respondents based their choices on remote control features, while 11 respondents found the features that supported energy comparison with other households to be very interesting. 18 respondents considered physical appearance as an essential feature that influenced their choice of the concepts, while 7 respondents were attracted to the manual control features.

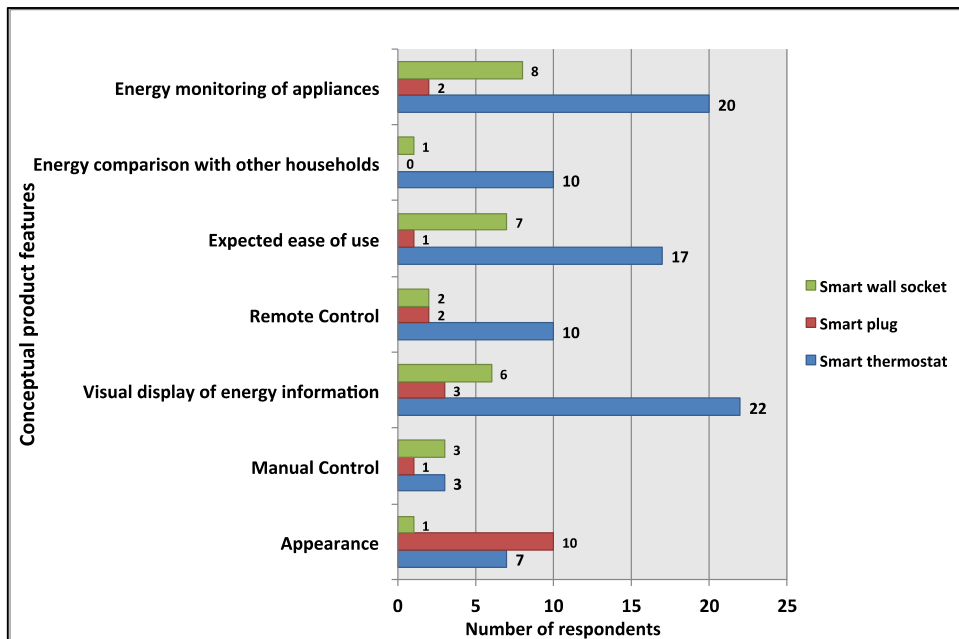

Figure 5.16. Features most preferred in the conceptual smart energy products

v) Perception of energy saving potential

When being asked which product had the highest potential to stimulate energy efficiency in households, 75% of the respondents selected the smart thermostat. Respondents stated that this was mainly because the smart thermostat performs the following functions:

- i. Provides total and continuous insight in the entire household energy use
- ii. Creates better insight and awareness in energy use in general, and in particular gas usage, which accounts for the highest energy usage in households
- iii. Monitors all connected individual household appliances

One respondent stated that, *“the smart thermostat is the most complete smart home energy manager. Unlike the smart plug and the smart wall socket, the smart thermostat is not fixed on any particular household appliance. It also shows a good overview on the wall and compares with the neighbour. This creates a kind of peer-pressure or competition with the rest of the neighbourhood”*. Another respondent added that, *“although the smart plug and the smart wall socket support optimal energy use in households, they are incomplete solutions focused too much on a detail level”*. One respondent said: *“We have a smart thermostat, since 2 years and this has saved us a lot of energy. Our energy bill has reduced enormously”*.

Only 15% and 11% of the respondents considered the smart plug and the smart wall socket respectively as the product that best supports efficient energy behaviour in households. For the respondents that had preference for the smart plug, the visual

display of energy information and monitoring of energy use of individual household appliances were considered as the most important feature that influenced their choices. Remote control and expected ease of use were jointly considered as the second most important feature.

vi) Other desired features

The respondents were asked to mention other features not given in the questionnaire, that they thought might be required in future HEMPs that stimulate energy-efficient behaviour in households. 44 respondents provided answers to this question. Automatic/remote control of appliances was mentioned 15 times as an essential feature of any smart energy product. According to one of the respondents, *"I prefer automatic energy saving. I would like the smart thermostat to automatically set my connected appliances on and off, especially when these are not in use (example the computer or television as a sort of standby-killer)"*. Other respondents (n= 29) mentioned the manual control of appliances, the monitoring of the power generated from photovoltaic (PV) systems, simplicity or ease of use as the features that should be incorporated in smart energy products.

Similar to the existing products, one of the questions in the survey was related to other features the respondents considered important in future HEMPs that stimulate energy-efficient behaviour in households. 26 respondents provided answers to this question.

Most of the respondents (n=8) stated that they would like features that enable them to compare their energy use independently with their neighbours. A respondent stated that, *"I want to have the possibility to compare my own self-generated with other end-users. I also do not need any form of mediation from third parties such as energy companies that could make use of all information the way they want"*.

Another group of respondents (n= 7) said they would like to incorporate features that combine household energy use, generation from solar PV's and electric cars. One of the respondents stated, *"the most important is to have a central system where various products could be connected irrespective of brand or protocol. Products should not only work with their software or infrastructure, this is unattractive"*. One respondent was of the view that incorporating features that provide an advice for extra savings in the smart thermostat could stimulate a better energy efficient behaviour. In the words of one of the respondents, *"It will be nice if the smart thermostat could furnish us with hints on how to save energy based on the registered personal profile"*. Another respondent considered it important that the smart thermostat gives an overview of energy use of all household appliances, self-generated renewable energy and use.

2 respondents suggested that the HEMPs should just be simple and make clear the added value for the end-user.

5.5 Discussion and conclusion

To support a more active involvement of end-users in household energy management, especially in a smart grid context, the development and introduction of new innovative smart energy products and services such as HEMPs will be required. The objective of this study was to explore the role of Industrial Design Methods (IDMs) in the development of new innovative smart grid products known as Home Energy Products (HEMPs), and evaluate end-users' perceptions of and preferences for existing and new conceptual HEMPs, and the functionalities of these products that best stimulate energy-efficient behaviour.

The conceptual HEMPs used as the basis for the questionnaire survey were designed during two students' design projects (2013 and 2014), at the faculty of Industrial Design Engineering, University of Twente (The Netherlands) in the framework of the course 'Sources of Innovation'.

The evaluation of both existing and conceptual HEMPs in this study was carried-out with the help of an online questionnaire survey, which was answered by 87 respondents. From those respondents, a relatively high percentage (95%) possessed either a bachelor's or master's degree, and a relatively high percentage lived in detached and semi-detached houses. About 35 of the respondents already owned one or more types of HEMP, while the others either did not have one, or did not know if they had one at home. Smart thermostats and smart meters were the most predominant HEMPs owned.

i. Development of new HEMPs

Four Industrial Design methods (IDMs) namely: Platform-driven product development (PDPD), Delft Innovation Method (DIM), Theory of inventive problem solving (TRIZ), and Technology Roadmap (TRM) were predominantly used in developing the conceptual HEMPs. The IDMs proved to be useful for the exploration towards inventive features. These methods provided a structured approach that aided the implementation of the most relevant aspects for an integrated development of the product concepts. Specifically, the IDMs supported a detailed exploration of technological possibilities, the opportunities that exist in the energy market and end-user preferences. Our analysis shows that these IDMs were mainly chosen because their combination covers the entire design process from a given task to the solution. The predominant use of DIM at the start of the design process helped the students in exploring what the best fields of interest might be in terms of smart grids related products and services. The predominant use of DIM shows that the development of future HEMPs for households will depend not only on the internal strengths of the companies now spearheading smart grids development, but also on the external wishes of end-users. DIM supported the clarification of the role and interests of various actors in the design process, and was found to be useful for determining a focus point out of the large smart grid topic.

Using TRM, the students were able to choose the most promising technology directions generated with DIM. TRM supported the identification of gaps in products for which there will be a need when the smart grid transition gains momentum on a household level. Different technologies, products, services, as well as markets and businesses were

mapped with TRM. TRM showed that a market pull rather than a technology push approach would be required to develop future HEMPs for households. Currently, a technology push approach is being experienced with regards to the development of smart energy products and services for households (Verbong et al., 2012; Obinna et al., 2016). This has in most case limited end-user engagement and interaction with these products and services. TRM allowed the extrapolation of future developments, from changes in technologies up to future market developments.

The use of TRIZ highlighted the importance of anticipating problems and conflicts that could arise in the design process. TRIZ supported the elimination of problems and contradictions that could negatively impact on the functionality of the product concept. TRIZ mostly provided a set of solutions for problems which might not be overcome with normal design methods. The application of TRIZ helped the students to make crucial and innovative design decisions that formed the basis for the rest of the product development process.

PDPD was used mostly in this project to make product design or parts of it easier implementable for future designs. PDPD was useful in developing products that consist of components that can be shared across a family of products, and then be developed and produced in a time- and cost-efficient manner. PDPD was used mostly in this project to make product design or parts of it easier implementable for future designs. It supported a transition from a modular towards more integral product architecture. These product platforms can be combined to different product families, which serve the different market segments.

The method served as a successful strategy to create variety with an eye on efficient use of resources. On the one hand, PDPD results in standardization of components in order to efficiently use available resources, at the other hand it results in identification of new target markets and product concepts in order to create variety and finally maximize profits.

The sequential application of these IDMs helped to identify and incorporate technological, societal, market and end-user aspects in the design of the innovative product concepts presented in this study.

ii. most attractive and favourite HEMPs

We evaluated both existing and new conceptual HEMPs in this study. For both categories, the smart thermostat was considered to be the most attractive and favourite product, and was considered to be the product with the highest potential to stimulate energy-efficient behaviour in households, mainly because it provides the most comprehensive insight in households' energy consumption and generation. In addition, the smart thermostat was considered a more complete solution compared to the smart plug and the smart wall socket that only measures the electricity use of specific household appliances connected to them. The smart wall socket appeared to be the second best-liked product, while the smart plug was considered the least attractive and least favourite product.

Though studies such as Newborough and Wood (2007), and Kobus (2016) have suggested either developing simple interfaces with limited information, people still like to have comprehensive insights in their electricity production and consumption

iii. most relevant features of the HEMPs

This study also shows that the features desired by end-users appeared in general to be the same for both the existing and new conceptual HEMPs. Visual display of energy information was considered the most appealing feature that influenced end-users' interest in both the existing and conceptual smart thermostat. Other desired features include monitoring of various household appliances, expected ease of use, remote control features and ability to compare their energy use with other households. These features were also considered the most attractive for the respondents who preferred the smart plug and smart wall socket.

iv. influence of design appearance

Our study establishes that new design features have an influence on user perception of HEMPs. Respondents indicated that appearance features appeared to be one of the least desired features for HEMPs. However, appearance did actually seem to influence people's opinion about a product. This can be seen in the evaluation of the conceptual smart plug. The number of respondents that chose the conceptual smart plugs was much higher compared to the existing smart plug. When being asked why people selected these products, they indicated that this was mainly a result of the design features such as appearance, which appeared to be better in the conceptual product. This may indicate that although people may not indicate that the physical appearance is relevant when selecting a new HEMP, the design of a product does actually influence their opinion towards the product. This finding is line with the findings of Karlin and colleagues that suggested the importance of paying greater attention to the physical design of HEMPs (Karlin et al., 2015).

v. importance of visual feedback

This study highlights the importance of visual information and monitoring feedback in stimulating energy-efficient behaviour. Although our evaluation focused on the category of HEMPs referred to as smart hardware, it reveals the importance of integrating intuitive user interfaces also in this category of products. This will make the functioning of smart hardware such as smart plugs and smart wall sockets to be more visible to users, thereby increasing their adoption and usage. As concluded by Kobus (2016), it is essential to develop intuitive user interfaces that could support users in using complex energy management systems. The study stressed the importance of clear, appealing and direct feedback that users can easily comprehend. Feedback is considered beneficial to change households' energy consumption, because it provides users with information about the results of their actions (Abrahamse et al., 2005; Kobus, 2016).

vi. desire for integrated solutions

Features desired by end-users in future smart grid products for households were mainly related to more incorporation of automatic and remote control features in smart energy products, and further simplifying future products. Also, our study reveals that end-users

would prefer HEMPs that combine information about various household energy generation and use to HEMPs that measure and report the energy use of separate household appliances. We conclude that HEMPs that make energy use most visible to end-users, that could be remotely controlled and which requires minimal effort to operate, may best stimulate energy-efficient behaviour in households. We therefore suggest that product and service suppliers pay more attention to the incorporation of features that support more visual interaction, that can automatically and remotely control energy use and requires the least operational effort, in the development of future HEMPs for households.

vii. relevance of the study

Our study establishes that intermediary products such as user interfaces are important in ensuring a more active involvement of end-users in household energy management. This study, to our knowledge, is the first public opinion survey carried out in the Netherlands focusing on current smart energy products. Previous studies such as (Van Dam et al., 2010; Apostolou and Reinders, 2016) have either focused on photovoltaic (PV)-powered products such as lights and chargers or one particular product such as energy monitor.

Our findings supplement the emerging but limited body of smart grid literature by highlighting the contribution of design in the development of new smart energy products for households, and the main features that household end-users desire in products that could stimulate energy-efficient behaviour, and with particular emphasis on the transition to smart grids. It contributes to the literature by providing a better understanding of the perceptions of electricity end-users about Home Energy Products (HEMPs). Since there is still significant progress to be made in the development and implementation of HEMPs, insights from this study could support the design and development of future HEMPs. It has also established that intermediary products such as user interfaces are important in ensuring a more active involvement of end-users in household energy management.

viii. limitations and future research

Our study has some limitations. First is the relatively small sample size, which makes our findings indicative rather than conclusive. Second, our survey focused mainly on one stakeholder group and did not involve other stakeholder groups such as the government, utilities, NGOs, experts and academics. Third is that majority of the survey respondents were already smart with their energy use, and lived in their own homes. They are not representative of the average Dutch population. Another limitation is that our study focuses on the perceived features of the products but not on the actual use experience regarding the interaction between users and their HEMPs. An additional user study would for instance show how easy the visual information can be managed and whether this complies with the advance assumptions of the users.

Chapter 6 Conclusion, discussion and recommendations

Chapter 6 summarizes the main findings from the previous chapters and provides the conclusions, discussion and recommendations for the design and development of future smart grid products and services.

6.1 Conclusions

As stated in the introductory chapter of the thesis, a large part of the electricity supply in household and residential areas is expected to be generated by various decentralized energy resources like wind turbines, photovoltaic (PV) solar systems and micro cogeneration systems. Smart grids provide the opportunity to make optimal use of renewable energy by matching demand to supply conditions, thereby facilitating the energy transition towards a sustainable society that is less dependent on fossil fuels.

The transition of the electricity system to smart grids requires electricity end-users at the low voltage household and residential areas to shift from consumers to a role of co-provider or active participants. End-users will have the opportunity to use energy efficiently, generate renewable energy locally, plan or shift energy consumption to most favourable times such as when renewable energy is most abundant or during low peak periods, and trade self-produced electricity that is surplus to household management (Netbeheer Nederland, 2012; Geelen, 2014; Kobus et al., 2016).

In order to support a co-provider role for end-users in the management of the electric power, several smart grid pilot projects have been initiated in Europe and America. In these projects, new energy products and services have been developed and tested. Also, various new smart energy products or Home Energy Management Products (HEMPs), which are aimed at supporting efficient energy behaviour in households, have been recently introduced in the energy market.

Regarding the development of products and services, the “innovation flower of industrial product design” shows that a combination of technology, societal, user, marketing, human, and design and styling factors are important for a successful and innovative product design (see Figure 1.7).

This thesis started with the observation that the energy performance of smart grids at the low-voltage household and residential areas could theoretically depend on four aspects namely: technical, financial, human and societal aspects (Reinders et al., 2012).

In addition to the development of new energy technologies that balance energy demand and supply, human aspects such as interaction of end-users with smart energy products, end-user behaviour towards energy-efficiency, and users’ experiences are considered important aspects to stimulate an active end-user participation in smart grids (ETPS, 2011; Top team Energy in Netherlands, 2012; IEA, 2011; Reinders et al., 2012; Geelen et al., 2013). Currently, limited knowledge exists regarding participation and experiences in smart grids, the effects of these products and services on energy performance of households, and expectations regarding current smart grid products and services.

Considering the importance of facilitating a more active participation of end-users in smart grids, this thesis explored and evaluated residential smart grids pilot projects, products and services by gathering insights from smart grid stakeholders and end-users, and exploring the role of design approaches and end-user expectations of HEMPs for households. These insights should support the development of new innovative smart grid products that support co-providers in energy management in a smart grid.

Therefore, the main research question addressed in this thesis is:

What design-related insights should be taken into account in the design and development of future residential smart grid projects, products and services in order to facilitate a more active participation of end-users in a smart grid?

The sub-questions, which helped to approach the main research question in a systematic and logical way, were:

- 1) What is the existing knowledge from literature on end-users of smart grids, current smart grid products and services for households and stakeholder involvement in smart grids? (Question is answered in Chapter 2)
- 2) How do smart grid stakeholders assess the development and performance of residential smart grid projects, and the products and services that are part of the projects? (Question is answered in Chapter 3)
- 3) What insights can be gained from evaluating current residential smart grid projects from a user perspective, in particular with regards to the energy performance of products and services implemented in these projects? (Question is answered in Chapter 4)
- 4) How can design interventions support the development of new products in future smart grid households? (Question is answered in Chapter 5)
- 5) Which functionalities do end-users prefer with regards to new products and services for smart grid households? (Question is answered in Chapter 5)

In the following paragraphs the conclusions of this thesis are presented as answers to the sub-research questions.

1st sub-research question:

What is the existing knowledge from literature on end-users of smart grids, current smart grid products and services for households and stakeholder involvement in smart grids?

This sub-question is answered in Chapter 2. Insights from Chapter 2 highlighted that a successful development and deployment of smart grids would require an increased end-user engagement, especially in the development of smart grids related products and services.

However, the literature review showed that end-user involvement is still very much limited, with current smart grids deployment approaches mainly focused on technological issues and use of economic incentives to influence end-user behavior in order to achieve the flexibility required to balance electricity demand and supply in the grid. End-users are still largely considered as passive or reactive participants in smart grids development. Their participation is mainly limited to the use of economic incentives to motivate them

to adopt smart grid technologies, and adjust their energy-related behavior to balance electricity demand and supply in the power grid.

The literature review emphasized the importance of supporting end-users as energy citizens or active participants in the transition to smart grids. Existing literature does not, however, provide adequate insights regarding how this co-provider role has been or could be facilitated in practice. It is also not clear from the literature how end-users are currently involved in smart grids, or how they can be supported as co-providers.

The literature review revealed the relevance of a better end-user and stakeholder involvement in smart grids deployment. An important aspect of end-user involvement in smart grids is the way end-users interact with smart grid products and services. Given the limited interaction between end-users and current products and services, the literature review showed that current products and services have not always supported an active involvement of end-users in smart grids deployment. Therefore, studies originating from the design field (e.g. Geelen et al., 2013a, Kobus et al., 2012, Van Dam et al. 2012) suggested that that design could play an important role in improving the involvement of end-users in smart grid development, and have explored the role of users as co-providers in smart grids.

It is established in Chapter 2 that limited information still exists with regards to how end-users and other stakeholders are currently involved in smart grids development at the low voltage household and residential areas.

To conclude, the literature review revealed a scientific research gap regarding the active involvement of end-users, especially in the design process of smart grid products and services. These findings necessitate a further field exploration aimed at further exploring the development and performance of residential Smart Grid projects, including products and services implemented in these projects.

2nd sub-research question:

How do Smart Grid stakeholders assess the development and performance of residential Smart Grid projects, and the products and services that are part of the projects?

This sub-research question was explored in Chapter 3. The views, perceptions and involvement of a broad range of smart grid stakeholders were explored in Chapter 3 regarding the set-up and implementation of residential smart grid pilot projects in the Netherlands, and the development and performance of residential smart grids, and products and services that may support an active participation of end-users in smart grids. This exploration became necessary due to the literature gap regarding the development and performance of residential smart grids projects and current products and services.

Semi-structured interviews were conducted with nine (9) stakeholders involved in the set-up and implementation of five different Dutch residential Smart Grid pilot projects:

electricity network operators, energy suppliers, and end-users from individual households and local energy cooperatives.

The Strategic Niche Management (SNM) processes, of building of social networks and learning in innovations, was employed as a framework to study the development and performance of residential smart grids.

This study showed that the European Union, national, provincial and municipal governments, grid operators, energy suppliers, household end-users, product and service suppliers, ICT companies, knowledge institutes and local energy cooperatives are currently involved in residential smart grid pilots.

The interviewed stakeholders stated that the active involvement of end-users is key for a successful development and implementation, confirming the insights gathered via literature (Chapter 2).

With regards to the development of smart grid products and services, Chapter 3 highlighted a technology-push approach, where the perspectives of the technical partners involved in the projects appear mainly dominate product and service development processes. The Distribution System Operators (DSO's) or grid operators appear to be the leading players in the development and implementation of residential smart grid projects. This is due to their interest in finding the best ways to facilitate demand side management of electricity at the end-user level, and avoiding future costs related to expanding the electricity infrastructure.

The result of this technology-based and top-down approach is the development of mainly complex technological solutions that function well, but in most cases are not easy for end-users to use and adopt.

Furthermore, a lack of integrated approach in smart grids products and services development was revealed in Chapter 3.

It was gathered from Chapter 3 that the complexities reported in existing smart grid products could be attributed to the set-up of residential smart grid pilot projects, and current approaches in developing the products and services offered in these projects. A dominantly technical approach originating from the fields of electrical engineering, power systems and digital technologies has been the basis for the development of these products and services. In this regard, the perspectives of the technical partners involved in residential smart grid projects, such as grid operators, energy suppliers and product and service suppliers were mainly the starting point of the development of these products and services such as Home Energy Management Products (HEMPs).

According to SNM, learning processes should not only be limited to the development and testing of technologies, but also on improving user practices. However, it can be concluded from this chapter that learning processes in residential smart grids is still very much focused on the developing, testing and improving new smart grid technologies. Limited attention is currently paid to simultaneously developing technology innovations in smart grids together with potential end-users from an early stage.

Though end-users are projected as important stakeholders in smart grids, and are also involved in smart grid projects, the way end-users are involved in current smart grids development appears to be based on the perception of end-users as passive participants. End-user involvement in current residential smart grid development is mainly limited to using these technologies and providing the necessary feedback required for improvements.

The technological complexity of current smart grid products confirmed in Chapter 3 created the need to provide more quantitative information regarding how end-users actually experience the usage of current smart grid products and services, and how this has supported a co-provider role.

3rd sub-research question:

What insights can be gained from evaluating current residential smart grid projects from a user perspective, in particular with regards to the energy performance of products and services implemented in these projects?

The third sub-research question was explored in Chapter 4. This study presented in Chapter 4 aimed to fill the gap related to limited knowledge available regarding the experiences and participation of end-users in residential smart grid pilots, and the energy performance of households in smart grid pilots where end-users are actively involved.

In this study, two residential smart grid pilots, PowerMatching City, Groningen (NL) and Pecan Street, Austin Texas (USA) have been compared regarding their energy performance and the experiences of users in these pilots. The objective of the comparison was to gain new insights that could support the successful deployment of future residential smart grids. Measured data on electricity generation and electricity consumption of households in 2013 and 2014 were evaluated. Existing reports with results of surveys of users were also analyzed.

The energy performance, which is based on households' energy consumption and generation patterns, disclosed a large difference in the electricity consumption and generation patterns of households in the PowerMatching City and Pecan Street pilots. The energy performance revealed that the average domestic electricity consumption of households in PowerMatching City was about four times lower compared to Pecan Street (2.6 GWh versus 10.1 GWh per year?). Higher average temperatures in Austin, and the usage of air-conditioning systems, appeared to have a major influence on the electricity consumption patterns in Pecan Street.

At the same time, households in Pecan Street generated a substantially higher amount of electricity compared to PowerMatching City (6.8 GWh versus 1.14 GWh). In 2013 and 2014, the electricity generated by households in Pecan Street was about 5 times higher compared to the generation in PowerMatching City. While the summer months accounted for the highest electricity generation in both pilots, the lowest energy generation occurred in the autumn and winter months. The higher solar irradiance and average installed power of renewable energy technologies, such as solar photovoltaics was the major influencing factor for the higher electricity generation in Pecan Street.

In general, participating households in both pilots consumed less energy than the average households in their region. The participation of the households in the pilots appeared to have supported an increased awareness in energy utilization. Households in Pecan Street consumed on average, 8% less electricity with respect to the USA average household domestic electricity consumption of 10.9 GWh; while households in

PowerMatching City consumed 19% less electricity compared to the Dutch average household domestic electricity consumption of 3.1 GWh. The average electricity consumption of households in Pecan Street was also lower than the average in Austin, which was around 12,000 kWh per year in 2013 and 2014 (Austin Energy, 2016).

In general, households in PowerMatching City appeared to have a higher potential to contribute to demand and supply balancing in the electricity network, because their electricity consumption from the grid was largely reduced with increased self-generation. Also, the energy performance of households in PowerMatching City appeared to have improved with the implementation of the smart grid technologies.

Comparing the design and set-up of the PowerMatching City smart grid pilot in Groningen (the Netherlands) and Pecan Street Smart Grid pilot in Austin (USA), it is observed that the way participants were involved in the pilots was quite similar. End-users in both pilots also had similar characteristics such as high income and educational level, and motivation to participate in smart grid pilots. However, a difference was observed in the involvement of participating end-users in the development of the implemented products and services. While participants in PowerMatching City took part in the development of elements of the HEMS, participants in Pecan Street mainly provided feedback to pre-determined HEMS tested in their homes.

A comparison of user experiences showed similar insights regarding the use of the technologies implemented in the pilots. Regarding the use of either manual or automated technologies, end-users in both pilots appeared to have preference for technologies that automatically shift their energy use. This is because these kinds of technologies require minimal effort to operate. Most of the participants in both pilots express satisfaction with the smart energy system in place, which increased their awareness and consciousness of their energy behavior. Though an effective use of smart energy products such as programmable thermostats could support efficient-energy behavior in the participating households, most participants in both pilots were not always capable of using the implemented technologies, such as smart programmable thermostats. This study shows that in most cases, end-users have difficulties comprehending the feedback provided by these products. Insights from this study reveal that the interaction between end-users and new energy technologies still remains challenging.

With regards to the energy performance of the households participating in both projects, this study concludes that existing smart grid set-ups, local climate and related needs for heating and cooling, the average capacity of installed energy generating technologies and the prevailing energy behavior largely influenced the pattern of households' electricity generation and consumption. Most importantly, the study confirms that the interaction between end-users and current smart grid technologies still remains a challenging task.

The literature review in chapter 2 pointed out that design interventions could be potentially beneficial for a more active involvement of end-users in smart grids. An important aspect of this involvement is interaction with products and services, and design is considered an important factor that could influence the success of products and services with end-users.

Therefore, chapter 5 has further explored the potential benefits of design interventions in the development of smart grids products and services.

4th sub-research question:

How can design interventions support the development of new products in future Smart Grid households?

The development and introduction of Home Energy Products (HEMPs) will be required to support a more active involvement of end-users in household energy management, especially in a smart grid context.

It was established in Chapter 5 that the interaction between end-users and current Smart Grid technologies still remains a challenging task.

Insights from chapter 2 suggested that design interventions could potentially support the design of better products, reduce the complexities associated with current smart grid products and services, and increase acceptance by end-users.

Studies conducted from a design perspective proposed that a closer insight in energy technologies in relation to appropriately matched design processes could support a better embedding of energy technologies in industrial product design, and therefore lead to more optimal products and services.

Given the potential role of design in the success of products and services that fit end-users demands and wishes, this section explored the role of Industrial Design methods (IDMs) in the design and development of new innovative smart grid related product concepts at the household level.

To address the 4th sub-research question, 10 IDMs were applied in a students' design project executed at the University of Twente in 2013 and 2014. The aim was to design and develop new Home Energy Products (HEMPs) for households.

This study shows that four IDMs namely: Platform-driven product development (PDPD), Delft Innovation Method (DIM), Theory of inventive problem solving (TRIZ), and Technology Roadmap (TRM) were predominantly used in developing the conceptual HEMPs. These methods provided a structured approach that supported the implementation of the most relevant aspects for an integrated development of the conceptual HEMPs. DIM was employed mostly at the start of the design process to explore what the best fields of interest might be in terms of HEMPs. TRM supported the choice of the most promising technology directions.

TRIZ supported the anticipation of problems and contradictions during the design process. PDPD aided the incorporation of modularity in the product design.

The sequential application of these IDMs helped to identify and incorporate technological, societal, end-user aspects, and market opportunities in the design of the innovative product concepts presented in this study.

Specifically, the IDMs supported the exploration of the market, including the current and future state of technological possibilities in the area of smart energy products.

This further highlight the importance of not only focussing on the technology aspects, but also market, and human factors relevant for the successful design of new smart energy products.

Since these IDMs were employed in a design project to develop ideas for new products that could stimulate energy-efficient behavior in households, end-user participation was rather limited. The design project mainly explored existing opportunities in the market and current technological possibilities regarding smart grid products and services.

The following sub-question explored therefore evaluated end-users' perceptions of and preferences for existing and new conceptual smart grid products known as Home Energy products or HEMPs, and the functionalities of these products that are most likely to stimulate energy-efficient behaviour.

5th sub-research question:

"Which functionalities do end-users prefer with regards to new products and services for smart grid households?"

The second sub-research question proposed in chapter 5 focused on the evaluation of the Home Energy Products (HEMPs) developed in a students' design project, as well as commercial HEMPs currently available in the market. This evaluation was focused on end-users' perceptions of and preferences for existing and new conceptual HEMPs, and the functionalities of these HEMPs they may best stimulate energy-efficient behavior. An online questionnaire survey was utilized for data collection.

Three types of HEMPS namely: smart thermostats, smart plugs and smart wall sockets have been analyzed.

It was observed that end-users preferred the same features for both the existing and new conceptual HEMPs. For both the existing and conceptual products evaluated in this study, the smart thermostat emerged as the most attractive and favourite product, and the product with the greatest potential to stimulate energy-efficient behavior in households. This is due to its ability to provide the most comprehensive insight in households' energy consumption and generation.

It was also seen as a more complete solution compared to the smart plug and the smart wall socket that focus on the electricity use of specific household appliances connected to them.

Furthermore, the main features that household end-users desire in products that could stimulate energy-efficient behavior are (1) visual display of energy information, (2) monitoring of energy use of household appliances, (3) remote control, and ease of use.

In addition to these features, it was also remarkable to observe that design appearance also appeared to have influenced the preferences of end-users regarding specific HEMPs.

In addition, it was remarkable to observe that though appearance features appeared to be one of the least desired features for HEMPs. However, design appearance also appeared to have influenced the preferences of end-users regarding specific HEMPs, establishing that new and better design features have an influence on user perception of HEMPs.

This evaluation further shows that end-users would prefer HEMPs that combine information about various household energy generation and use to HEMPs that measure and report the energy use of separate household appliances.

The finding of this section supplements the emerging but limited body of Smart Grid literature by highlighting the main features that household end-users desire in products that could stimulate energy-efficient behaviour, and with particular emphasis on the transition to Smart grids. It contributes to the literature by providing a better understanding of the perceptions of electricity end-users about Home Energy Products (HEMPs). Specifically, this survey has provided an improved understanding of how consumers perceive current smart energy products aimed at supporting household energy management. Since there is still significant progress to be made in the development and implementation of HEMPs, insights from this study could support the design and development of future HEMPs.

The relevance of this study lies in the establishment that intermediary products such as user interfaces are important in ensuring a more active involvement of end-users in household energy management, and the desire by end-users to have more integrated HEMPs that will support them in energy management.

Based on the findings from the individual sub-questions (chapters), the following section presents some recommendations that could support the design and development of smart grid products and services.

6.2 Discussions and recommendations for the design of future smart grid products and services

The overall research question addressed in this study is formulated as follows:

What design-related insights should be taken into account in the design and development of future residential smart grid projects, products and services in order to facilitate a more active participation of end-users in a smart grid?

In order to answer this question, the findings from sub-questions (chapters) are pulled together to provide recommendations that could support the deployment of residential smart grids and the design and development of smart grids related products and services.

It is recommended to employ a more integrated approach where end-users and other relevant stakeholders cooperate better in the deployment of residential smart grid projects, and in the development process of associated products and services. This is as a result of complexities reported with existing smart grid products and services, in most cases make end-user acceptance and adoption of smart grid products and services challenging.

Participatory design or co-design approaches could be beneficial in aligning end-user interests with the interests of the other stakeholders especially at the early stages of smart grids product and service development, thereby eliminating complexities in present and new to be developed products and services.

This study shows that in the future, several Home Energy Management products aimed at saving energy or increasing end-users' awareness of energy consumption will emerge. We recommend the inclusion of the end-users in the design process to enable them contribute valuable insights for the development process.

Another recommendation is related to either providing complex (high technology) solutions for end-users or simple (low technology) solutions. We propose the development of both easy to use and comprehensive solutions to enable end-users to manage and control their household energy generation and consumption better. It is therefore important to develop tools that match the knowledge and experiences of different end-user groups. The low technology solutions should be developed for the category of end-users that have little technical experience, while the "techies" or those that have profound interest in high technologies should be provided with these kinds of technologies.

This recommendation is based on the affirmation of the existence of different end-user segments with different needs and abilities. This study demonstrates that while certain users would prefer simple interfaces with limited information, others require products that provide comprehensive insights in their energy consumption and generation.

Currently, limited services exist that support end-users in the usage of various technological products. This study shows that various products and services would be required to support an active participation of end-users in the future energy system. These include products and services that provide insight in energy generation and

consumption of households, show usage patterns of household devices and prices of electricity in the grid, enable manual programming of smart appliances, and enable end-users to compare their energy usage with other households.

We therefore advocate that designers and developers of smart grid products and services for households take into account the particular end-user category they are targeting. For instance, particular groups such as young or old people, technical and non-technically inclined people should be targeted in the development of future products and services. These various end-users should be carried along in the design and development of various products and services.

For future large-scale development of smart grids at the local (household and neighbourhood) level, more emphasis should be placed on developing products and services on a small scale, focussing on specific user segments. In this regard, design and co-creation approaches could support the creation of successful products with a better performance than the existing.

Product and service designers should aim at developing integrated products and services with increased modularity, which allows new services to fit easily and improving the ability to meet various end-user needs. This suggestion is as a result of the lack of standardized products, and limited interoperability between existing products and services.

We advocate the design and styling aspects be incorporated. The findings from this study highlights that design features could have an influence on how end-users perceive and utilize Home Energy Management Products (HEMPs) in achieving their energy-related goals. For instance, the evaluation of the conceptual smart plug in chapter 5 shows that end-users had more preference for the conceptual smart plugs, which appeared to have more intuitive design features than the existing commercial smart plug.

Finally, it is recommended that smart grid set-ups employ a User-Centred Approach in the design and implementation stages. This approach will support the development of improved, more simplified, intuitive and user-friendlier Smart Grid products and services. This approach will support a better incorporation of the wishes and demand of end-users in the design and development of future Smart Grids products and services, and stimulate more active participants in future Smart Grids.

To achieve broader societal embedding of smart grid products and services, it is suggested to involve end-users better in the design and development of these products and services from the onset, and not to use them only as sources of market information or to adjust pre-determined products and services. This approach will ensure a more active participation of end-users and enable the behavioural change required from end-users in order to balance electricity demand and supply balancing in the grid.

We therefore recommend that a better alignment of technology development and the user context or environment would be required for future developments leading to better smart grid products and services.

6.3 Theoretical and practical contributions

Smart grids development in residential areas will require more interaction between end-users, their appliances, utility companies, and other parties that will be generating energy from various renewable sources. The role of end-users will change from passive receivers of energy to an empowered and crucial part of the electricity system (Wolsink, 2011; Geelen et al., 2013; Gungor et al., 2012).

As stated in the introductory chapter of this thesis, the energy performance of smart grids in residential neighbourhoods could theoretically depend on technical, financial, human and societal aspects (Reinders et al., 2012). In addition to the development of new energy technologies that balance energy demand and supply, human aspects such as interaction of end-users with smart energy products, end-user behaviour towards energy-efficiency, and users' experiences are considered important aspects to stimulate an active end-user participation in smart grids (ETPS, 2011; Top team Energy in Netherlands, 2012; IEA, 2011; Reinders et al., 2012; Geelen et al., 2013). However, currently, limited knowledge exists regarding participation and experiences in smart grids, the effects of these products and services on energy performance of households, and expectations regarding current smart grid products and services.

Considering the importance of facilitating a more active participation of end-users in smart grids, this thesis explored and evaluated residential smart grids pilot projects, products and services by gathering insights from smart grid stakeholders and end-users, and exploring the role of design approaches and end-user expectations of Home Energy Management Products (HEMPs) for households. The research presented in this study was carried out in the context of Industrial Design Engineering (IDE). The discipline of IDE plays a key role in product development. The "innovation flower of industrial product design" (Figure 1.7) shows that a combination of technology, societal, user, marketing, human, and design and styling factors are important for a successful and innovative product design. This research contributes towards the development of the field of IDE by investigating smart grid products and services for households, thereby providing knowledge and insights that was previously not available. Namely, this study helped to shed more light on actual user acceptance of new energy products and services in smart grids by providing both qualitative and quantitative insights related to people's participation, experiences, and expectations. This complements the limited theoretical knowledge that exists regarding to what extent smart grids deployment has facilitated a more active participation of end-users.

The research presented in this thesis is interdisciplinary in nature because of its embedding in the field of industrial design engineering, regarding the technological performance of smart grid technologies in the field and user interaction with and societal embedding of these technologies. The multidisciplinary nature of the research presented in this thesis differentiates it from previous user studies in smart grids.

Given the interdisciplinary nature of the research, this study contributes to the literature fields of technology innovation, user-technology interaction, smart energy systems and user interface design.

Given that smart grid technologies have become available only since recently, this study contributes to more theoretical knowledge available on the functioning and effects of

these products and services on energy performance of households. The insights from this study could support future research and product development of new innovative smart grid products that support end-users as co-providers in energy management in a smart grid as well as the design and development of new or improved smart grid products with a better acceptance by users. These are issues that have rarely been addressed by other researchers.

This study further highlights the important role design and designers could play in the development of new products in future smart grid households. It contributes to the design field by generating insights and knowledge related to aspects that designers need to take into consideration when designing smart grid products such as HEMPs.

In general, the results of this thesis contributes to the limited available knowledge on the user side of smart grids research. While too much attention has been paid to investigating the technical aspects related to smart grids development, this study combines insights from both technology aspects (current functioning of smart grid technologies), and user aspects (user experiences and expectations of smart grid technologies).

6.4 Research limitations

Our study has some limitations, which have been mentioned in the individual chapters. However, the major limitations are outlined below.

First is the relatively small number of stakeholders interviewed (Chapter 3), and the non-incorporation of the views of other relevant stakeholders in smart grids development such as the government, energy suppliers and product and service suppliers. This is due to limited access to smart grid users. This could be resolved by involving researcher universities as major players in the deployment and implementation of smart grid pilot projects. Currently, commercial parties are the major participants in these projects.

Second is the limited number of households involved in our evaluation (Chapter 4), the lack of equal data from PowerMatching City related to the usage of individual household appliances, and the fluctuating number of persons in the households and the missing data related to these fluctuations in the PowerMatching City database. This is mainly because of relocations of households participating in these pilots, and the lack of data related to fluctuations in households. A possible solution is ensuring that while resetting the meters of new households in smart grid pilots, previous data are appropriately recorded and stored for future reference purposes.

Third is the lack of pre- and post-energy data in the analysis of the impacts of the implemented smart grid technologies. This is a general problem for the energy performance of households participating in smart grids. This can be resolved by a better collaboration between smart grid pilot developers and energy companies in order to have access to energy usage information of households prior to their participation in smart grid pilots.

The fourth limitation is that the majority of the survey respondents in the user survey (Chapter 5) were already “smart” or experienced with their energy use, and lived in their own homes, and therefore not representative of the average Dutch population. This is because majority of the Dutch population live in flats or apartment complexes.

The final major limitation is the focus of the user survey (Chapter 5) on the perceived features of the products but not on the actual use experience regarding the interaction between users and their HEMPS. This focus is because the conceptual HEMPS that were evaluated in this study are not yet commercially available. An additional user study would for instance show how easy the visual information can be managed and whether this complies with prior assumptions of the users.

Despite these limitations, this research contributes to the literature by adding more quantitative, in-depth insights to the limited knowledge available on user experiences and energy performance of households in smart grids.

6.5 Suggestions for further research

Besides theoretical contributions, the findings of this study have implications for smart grid project developers and design practitioners. This study has gathered insights regarding the current state of affairs of residential smart grids development and deployment and serves as a starting point for further research in this field for the improvement of smart grid products and their related services.

Future research should focus on further in-depth qualitative and quantitative evaluation of the energy performance of households in smart grids. Specifically, future research should aim at identifying and using various relevant indicators to quantify the extent to which implemented technologies facilitate efficient-energy behaviours in households participating in smart grids. This aspect will be interesting for smart grid experts because the acceptance and adaptation of smart grid technologies by end-users is dependent on to what extent these technologies are considered as products that are used by people.

References

Abrahamse, W., Steg, L., Vlek, C. and Rothengatter, T. (2005) 'A review of intervention studies aimed at household energy conservation', *Journal of Environmental Psychology*, Vol. 25, No. 3, pp.273–291.

Agentschap NL, 2013 Handleiding bij de regeling smart-grids-projecten.

Agentschap NL, 2013. Topsector energie: tkswitch2smart grids. Handleiding bij de regeling smart-grids-projecten.

Altshuller, G. (1996). *And suddenly the Inventor appeared: TRIZ, the theory of inventive problem solving*, 2nd edition, Technical Innovation Center, Worcester, MA.

Apostolou, G. and Reinders, A. (2016) 'How do users interact with photovoltaic-powered products? Investigating 100 'lead-users' and 6 PV products', *J. Design Research*, Vol. 14, No. 1, pp.66–93.

Austin Energy. <http://austinenergy.com/wps/portal/ae/about/reports-and-data-library/data-library/energy-use-and-sales>. [Accessed April 24, 2016].

Balta-Ozkan, N., Davidson, R., Bicket, M., and Whitmarsh, L. (2013) 'Social barriers to the adoption of smart homes', *Energy Policy* 63, 363–374.

Bergsma, J., and Binnema, M. (2013) 'The Incubator', Master report 'Sources of Innovation', University of Twente.

Biesiot W, Noorman KJ. Energy requirements of household consumption: a case study of The Netherlands. *Ecological Economics* 1999; 28(3): 367-383.

Blessing, L., Chakrabarti, A., 2009. *DRM, a Design Research Methodology*. Springer.

Bliek, F., van den Noort, A., Roossien, B., Kamphuis, R., de Wit, J., van der Velde, J., Eijgelaar, M., 2010. Power Matching City, a living lab smart grid demonstration. *Innovative Smart Grid Technologies Conference Europe (ISGT Europe) 2010*, 1–8, IEEE PES.

Bloomberg, New EnergyY finance. *Energy Outlook 2017*. <https://www.bloomberg.com/company/new-energy-outlook/>. [Accessed April 12, 2017].

Bork S., Schoormans J.P.L., Silvester S., Joore P. (2015) 'How actors can influence the legitimization of new consumer product categories: A theoretical framework', *Environmental Innovation and Societal Transitions* 16, pp 38-50.

- Buijs, J. (2003). Modeling product innovation process, from linear logic to circular chaos. *Creativity and Innovation Management*, 12(2), 76–93.
- Caniëls, M.C.J., Romijn, H.A., 2008. Strategic niche management: towards a policy tool for sustainable development. *Technology Analysis and Strategic Management* 20, 245–266.
- Chappells, H. 2003. *Re-Conceptualizing Electricity and Water: Institutions, Infrastructures and the Construction of Demand*. Lancaster: Lancaster University.
- Centraal Bureau voor de Statistiek (2012). *Hernieuwbare energie in Nederland 2011*.
- Central Bureau for statistics Netherlands (2013). <http://www.cbs.nl/nl-3816-NL/menu/themas/industrieenergie/publicaties/artikelen/archief/2013/2013-wm.htm>. Accessed July 14, 2013.
- Centraal Bureau voor de Statistiek (2017). <http://statline.cbs.nl/Statweb/publication/>.
- Centraal Bureau voor de Statistiek.
<http://statline.cbs.nl/Statweb/publication/?DM=SLNL&PA=81528NED&D1=1&D2=0,3,I&D3=0-1,8,11-13,15,22,33,74,151,221,331,384,448&D4=a&VW=T>. [Accessed 22.04.16].
- Centraal Bureau voor de Statistiek, n.d. Statline [WWW Document]. URL www.cbs.nl. [Accessed May 30, 2016].
- Coenen, L., Raven, R., Verbong, G., 2010. Local niche experimentation in energy transitions: A theoretical and empirical exploration of proximity advantages and disadvantages. *Technology in Society* 32, 295–302.
- Darby, S., McKenna, E. 2012. Social implications of residential demand response in cool temperate climates. *Energy Policy*; 49, 759–69.
- De Meester, T., Marique, F.M, De Herde, A, Reiter S., 2013. Impacts of occupant behaviours on residential heating consumption for detached houses in a temperate climate in the northern part of Europe. *Energy and Buildings*; 57:313–323.
- DeWaters, J., and Powers, S., 2011. Energy literacy of secondary students in New York State (USA): A measure of knowledge, affect, and behavior. *Energy Policy*, 10.1016/j.enpol.2010.1012.1049.
- DNV KEMA, 2015. Information leaflet about Powermatching City.
- ECME Consortium, 2010. *The Functioning of Retail Electricity Markets for Consumers in the European Union: Final Report*. Brussels: Directorate-General for Health & Consumers, European Commission Retrieved January 12, 2017, from <http://londoneconomics.co.uk/wp-content/uploads/2011/09/9-The-functioning-of-retail-electricity-markets-in-the-European-Union.pdf>.

Energieonderzoek Centrum Nederland (ECN) et al., 2016. Nationale Energieverkenning 2016. ECN Amsterdam/Petten.

Eggink, W., A. Reinders, and Meulen, B., 2009. 'A practical approach to product design for future worlds using scenario-development', In: Proceedings of the 11th Engineering and Product Design Education Conference, Creating a better world: Institution of Engineering Designers, Wiltshire UK.

Eggink, W., and Reinders, A., 2013. 'The Design and Styling of Technology-based Innovations: Theory and Practical cases, 5th International Congress of International Association of Societies of Design Research, 5th IASDR Tokyo.

Ehrhardt-Martinez, K., Donnelly, K.A., Laitner, J.A. 2010. "Advanced Metering Initiatives and Residential Feedback Programs: A Meta-Review for Household Electricity-Saving Opportunities." Prepared for American Council for an Energy-Efficient Economy, Washington, DC.

Elsevier, 2017. <https://www.elsevier.com/solutions/scopus>. [Accessed January 2, 2017].

Elzen, B., Geels, F.W., Green, K. (Eds.), 2004. System Innovation and the Transition to Sustainability. Theory, Evidence and Policy. Edward Elgar, Cheltenham.

Enerdata intelligence and consulting, 2016. Global Energy Trends, 2016. <https://www.enerdata.net/publications/reports-presentations/peak-energy-demand-co2-emissions-2016-world-energy.html> [Accessed May 11, 2017].

Energieonderzoek Centrum Nederland (ECN) ECN et al., 2012. Energy trends 2012. <http://www.energetrends.info>. [Accessed May 12, 2012].

Energieonderzoek Centrum Nederland (ECN) ECN et al., 2014. Energy trends 2014. <http://www.energetrends.info>. [Accessed May 31, 2014].

Energieonderzoek Centrum Nederland (ECN) ECN et al., 2016. Nationale Energieverkenning 2016. ECN Amsterdam/Petten.

Entrop, B., 2013. Assessing energy techniques and measures in residential buildings: A multidisciplinary perspective, Ph.D. Thesis University of Twente.

European Commission, 2010. Energy 2020 — A Strategy for Competitive, Sustainable and Secure Energy. Communication from the Commission. COM 639 final.

European Commission, 2011. Energy Roadmap 2050: Communication from the Commission to the European Parliament, the Council, the European Economic and Social Committee and the Committee of the Regions, EC, Brussels.

European Technology platform smart grids, 2010: Strategic Deployment Document for Europe's Electricity Networks of the Future. http://www.smartgrids.eu/documents/SmartGrids_SDD_FINAL_APRIL2010.pdf.

European Technology Platform Smart Grids, 2011. Smart Grids European Technology Platform. <http://www.smartgrids.eu>. Accessed November 28, 2012.

European Technology Platform Smart Grids, 2010. Strategic deployment Document for Europe's Electricity Networks of the Future. Retrieved January 14, 2017 from http://www.smartgrids.eu/documents/SmartGrids_SDD_FINAL_APRIL2010.pdf.

European Union, 2011. Renewables Make the Difference, EU, Brussels.

European environmental agency, 2013. Achieving energy efficiency through behaviour change: what does it take?. Technical report No 5.

Executive Office, 2011. A Policy Framework for the 21st Century Grid: Enabling Our Secure Energy Future. Executive Office of the President of the United States, Washington DC.

Exxon Mobil, 2012. The outlook for Energy: A view to 2040, Exxon Mobil, USA.

Exxon Mobil, 2017. 2017 outlook for Energy: A view to 2040, Exxon Mobil, USA.

Fang, X., Guoliang, X., Satyajayant, M., Yang, D., 2012. Smart Grid- The New and Improved Power Grid: A Survey. Article in IEEE communications and Amp tutorials.

Findeisen, E., Haanstra, W., 2013. Buffer Link: Smart Home Energy Management. Master report 'Sources of Innovation', University of Twente.

Foxon, T.J., 2013. Transition pathways for a UK low carbon electricity future. Energy Policy; 52: 10-24.

Gangale, F., Mengolini, A., Onyeji, I., 2013. Consumer engagement: An insight from Smart Grid projects in Europe. Energy Policy, 60, 621-628.

Gaviano, A., Weber, k., Dirmeier, C., 2012. Challenges and Integration of PV and Wind Energy Facilities from a Smart Grid Point of View. Energy Procedia 25: 118 – 125.

Geelen, D., Reinders, A. and Keyson, D., 2013. Empowering the End-User in Smart Grids: Recommendations for the Design of Products and Services. Energy Policy, 61, 151-161. <http://dx.doi.org/10.1016/j.enpol.2013.05.107>

Geelen, D., Scheepens, A., Kobus, C.B.A., Obinna, U., Mugge, R., Schoormans, J.P.L., Reinders, A., 2013. Smart energy households' field tests in The Netherlands with a design-driven approach, in: 4th European Innovative Smart Grid Technologies (ISGT) Conference. Copenhagen, Denmark, pp. 1-5.

Geelen, D., Vos Vlamings, M., Filippidou, F., Van den Noort, A., Van Grootel, M., Moll, H., Reinders, A., Keyson, D., 2013. An end-user perspective on smart home energy systems in the PowerMatching City demonstration project. 4th IEEE PES Innovative Smart Grid Technologies Europe (ISGT Europe), Lyngby, 6-9 October 2013, 1-5.

Geelen, D., 2014. Empowering end users in the energy transition: An exploration for products and services to support changes in household energy management. Ph.D. Thesis Delft University of Technology.

Geels, F.W., and J. Schot. 2007. Typology of sociotechnical transition pathways. *Research Policy* 36, no. 3: 399–417.

Geels, F.W., Schot, J., 2010. Managing sustainable innovation journeys. In: Grin, J., Rotmans, J., Schot, J. (Eds.), *Transitions to Sustainable Development. New Directions in the Study of Long Term Transformative Change*. Routledge, New York, pp. 80–92.

Giordano, V., Gangale, F., Fulli, G., Sánchez Jiménez, M., 2011. "Smart Grid projects in Europe: lessons learned and current developments", Joint Research Centre of the European Commission, Institute for Energy.

Giordano, V., Fulli, G., 2012. A business case for Smart Grid technologies: a systemic perspective. *Energy Policy*; 40: 252–259.

Goulden, M., Bedwell, B., Rennick-Egglestone, S., Rodden, T., Spence, A., 2014. Smart grids, smart users? The role of the user in demand side management, *Energy Research and Social Science* 2, 21–29.

Grondzik, W.T., Kwok, A.G., Stein, B., Reynolds, J.S., 2010. *Mechanical and electrical equipment for buildings* (11th. ed.). John Wiley & Sons, Inc. USA.

Guerra Santín O., Itard L., Visscher H., 2009. The effect of occupancy and building characteristics on energy use for space and water heating in Dutch residential stock. *Energy and Buildings*; 41(11):1223-1232.

Gungor, V.C., Sahin, D., Kocak, T., Ergüt, S., Buccella, C., Cecati, C. and Hancke, G.P., 2012. Smart Grids and Smart Homes: Key Players and Pilot Projects. *IEEE Industrial Electronics Magazine*, 6, 18-34.

Gungor, V.C., Sahin, D., Taskin, K., Ergüt, S., Buccella, C., Cecati, C., Hancke, G.P., 2011. Smart Grid Technologies: Communication Technologies and Standards. *IEEE Transactions on industrial informatics*, 7(4): 529–39.

Han, J., Choi, C.S., Park, W. K, and Lee, I., 2011. 'Green home energy management system through comparison of energy usage between the same kinds of home appliances', In: *Proceedings of the 15th IEEE international symposium on consumer electronics (ISCE)*: p.1–4.

Hommels, A., P. Peters, and W.E. Bijker. 2007. Techno therapy or nurtured niches? Technology studies and the evaluation of radical innovations. *Research Policy* 36, no. 7: 1088–99.

Honebein, P.C., Cammarano, R. F., Boice, C., 2011. Building a Social roadmap for the smart grid. *The Electricity Journal* 24, 78–85.

Hoogma, R., Kemp, R., Schot, J.W., Truffer, B., 2002. Experimenting for Sustainable Transport. *The Approach of Strategic Niche Management*. Spon Press, New York.

IPCC Climate change 2014, Synthesis Report, " Intergovernmental Panel on Climate Change, 2015, First published 2015 ISBN 978-92-9169-143-2: http://www.ipcc.ch/pdf/assessmentreport/ar5/syr/SYR_AR5_FINAL_full.pdf.

International Energy Agency, 2011. *Technology Roadmaps: Smart Grids*. IEA, Paris.

International Energy Agency, 2012. *World Energy Outlook*, IEA, Paris.

International Energy Agency, 2016. *Energy Technology Perspectives 2016*, IEA, Paris.

Joint Research council European Commission, 2011. *Smart Grid Projects in Europe: Lessons learned and current developments*. European commission, The Netherlands.

Joint Research council European Commission, 2014. *Smart Grid Projects Outlook 2014*. <http://ses.jrc.ec.europa.eu/smart-grids-observatory>. [Accessed February 2, 2017].

Karlin, B., Ford, R., Sanguinetti, A., Squiers, C., Gannon, J., Rajukumar, M., Donnelly, K.A., 2015. 'Characterization and Potential of Home Energy Management (HEM) Technology', Empower Efficiency, LLC.

Karray F., Alemzadeh, M., Saleh J., and Arab, M., 2008. 'Human-Computer Interaction: Overview on State of the Art', *International journal on smart sensing and intelligent systems*, Vol. 1, No.1.

Kemp, R., Schot, J., Hoogma, R., 1998. Regime shifts to sustainability through processes of niche formation. *The approach of strategic niche management. Technology Analysis and Strategic Management* 10,175–196.

Kemp, R., Rip, A., Schot, J., 2001. Constructing transition paths through the management of niches. In: Garud, R., Karnoe, P. (Eds.), *Path Dependence and Creation*. Lawrence Erlbaum, London, pp. 269–299.

Klein, A., Merkel, E., Pfluger, B., Held, A., Ragwitz, M., Resch, G., Busch, S., 2010. Evaluation of different feed-in tariff design options—best practice paper for the International Feed-In Cooperation. A report commissioned by the Ministry for the Environment, Nature Conservation and Nuclear Safety (BMU).

Kobus, C.B.A., Mugge, R. and Schoormans, J.P.L., 2012. 'Washing When the Sun Is Shining: How Users Interact with a Household Energy Management System', *Ergonomics*, 56, 451-462. <http://dx.doi.org/10.1080/00140139.2012.721522>.

Kobus, C.B.A., Klaassen, E.A.M., Mugge, R. and Schoormans, J.P.L., 2015. A real-life assessment on the effect of smart appliances for shifting households' electricity demand. *Applied Energy*, 147, 353-343.

Kobus, C., 2016. 'A switch by design: User-centred design of smart energy technologies to change habits of using energy at home', Ph.D. Thesis; Delft University of Technology.

Kumar, R., 2014. *Research Methodology: A step-by-step guide for beginners* (4 ed.). Sage publications incorporated London.

LaMarche, J., Cheney, K., Christian, S. and Roth, K., 2011. 'Home Energy Management Products and Trends', The Fraunhofer Center for Sustainable Energy Systems, Cambridge, MA.

LaMarche, J., Cheney, K., Akers, C., Roth, K., and Sachs, O., 2012. 'Home Energy Displays: Consumer Adoption and Response', The Fraunhofer Center for Sustainable Energy Systems, Cambridge, MA.

Liao H.C., Chang, T.F., 2002. Space-heating and water-heating energy demands of the aged in the US. *Energy Economics*, 24(3), 267-284.

Naus, J., van Vliet, B.J.M., Hendriksen, A., 2015. Households as change agents in a Dutch smart energy transition: On power, privacy and participation *Energy Research & Social Science* 9:125–136.

Ngar-yin Mah, D., van der Vleuten J.M., Hills, P., Tao, J, 2012. Consumer perceptions of smart grid development: Results of a Hong Kong survey and policy implications. *Energy Policy* 49, 204–216.

National Institute for Family Finance Information. <https://www.nibud.nl/consumenten/energie-en-water/>. [Accessed April 18, 2016].

National Institute for family Finance Information. <https://www.nibud.nl/consumenten/energie-en-water/>. [Accessed May 13, 2016].

Netbeheer Nederland, 2012. The road to a sustainable and efficient energy supply Smart Grids Roadmap, version 11.

Netbeheer Netherland, 2012. Global inventory and Analysis of Smart grid demonstration projects.

- Netbeheer Nederland, 2014. <http://www.netbeheernederland.nl/smartgrids/>. [Accessed 25 February, 2015].
- Netherlands Ministry of Economic Affairs, 2010. Op weg naar intelligent netten in Nederland. Discussion document of the task force smart grids.
- Netherlands Ministry of Economic Affairs, 2012. IA Special: Innovation on smart grids and energy storage. Agentschap NL, Den Haag.
- Netherlands ministry of economic affairs, 2013. PowerMatching City II (<http://www.rvo.nl/sites/default/files/2013/09/PowerMatchingCity2011.pdf>). [Accessed February 2, 2015].
- Netherlands Ministry of Economic Affairs, 2013. Your Energy Moment: Smart grids with the consumers. <http://www.rvo.nl/sites/default/files/2013/09/JouwEnergieMoment.pdf>. [Accessed February 4, 2015].
- Netherlands Ministry of Economic Affairs, 2013. Cloud Power Texel. <http://www.rvo.nl/sites/default/files/2013/09/CloudPowerTexelUK.pdf>. [Accessed February 17, 2015].
- Netherlands Ministry of Economic affairs, 2013. Smart Grids in sustainable Lochem. <http://www.rvo.nl/sites/default/files/2013/09/IntelligentnetinduurzaamLochemUK.pdf>. [Accessed February 16, 2015].
- Netherlands Consumers' Association. [online] <https://consumentenbond.nl/energie-vergelijken/energiemeter> (Accessed October 10, 2016).
- Netherlands Environmental Center. <https://www.energieverbruiksmanager.nl>. Accessed 17 October 2016.
- Ngar-yin Mah, D., Van der Vleuten, J.M., Hills, P., Tao, J., 2012. Consumer perceptions of smart grid development: Results of a Hong Kong survey and policy implications. *Energy Policy* 49, 204-216.
- Nye, M., Whitmarsh, L., Foxon, T., 2010. Socio psychological perspectives on the active roles of domestic actors in transition to a lower carbon electricity economy. *Environment and Planning A*, 42, 697-714.
- Obinna, U., Joore, P., Wauben, L., Reinders, A., 2013. "Water related sustainable innovations and the smart grid", in Proceedings of the 16th European Roundtable on Sustainable Consumption and Production (ERSCP).
- Obinna, U., Wauben, L., Joore, P., Reinders, A., 2016. Insights from stakeholders of five residential smart grid pilot projects in the Netherlands. *Smart Grid and Renewable Energy*; 7:1-15.

Obinna, U., Joore, P., Wauben, L., and Reinders, A., (2014) 'A design-driven approach for developing new products for Smart Grid households', in Proceedings of the IEEE ISGT conference, Istanbul.

OECD, 2014. 'Education at a Glance 2014: OECD Indicators', OECD Publishing. <http://dx.doi.org/10.1787/eag-2014-en>.

Pahl, G., Beitz, W., 1984. Engineering Design, London Design council, London.

Park, C.K., Kim, H. J, and Kim, Y.S., 2014. 'A study of factors enhancing smart grid consumer engagement'; Energy Policy 72: 211–8.

Pecan Street Organization, 2015. Final technology performance report 2015.

Pecan Street Organization. <https://dataport.pecanstreet.org/data/database> [Accessed March 13, 016].

Pecan Street Organization. <https://dataport.pecanstreet.org/data/interactive> [Accessed March 15, 2016].

Peffer T, Pritoni M, Meier A, Aragon C, Perry D. How people use thermostats in homes: a review. Build. Environ. 2011; 46: 2529–2541.

Peslak, A., 2005. 'A framework and implementation of user interface and human-computer interaction instruction', Journal of Information Technology Education, 4: 189-205.

Powermatching City, 2014. Final report working group customer research version 1.0, 2014.

PowerMatching City database.

Ragwitz, M., Held, A., Stricker, E., Krechting, A., Resch, G., Panzer, C., 2010. Recent experiences with feed-in tariff systems in the EU—a research paper for the International Feed-in Cooperation. A Report Commissioned by the Ministry for the Environment, Nature Conservation and Nuclear Safety.(BMU).

Raven, R.P.J.M., 2005. Strategic niche management for biomass. Ph.D. Thesis, Eindhoven University of Technology, The Netherlands.

Reinders, A., 2008. 'Product-integrated PV applications – How industrial design methods yield innovative PV-powered products', Oral presentation, Proceedings of 33rd IEEE Photovoltaic Specialists Conference, San Diego.

Reinders, A., Boer, A., de Winter, A., and Haverlag, M., 2009. 'Designing PV Powered LED products – Integration of PV technology in innovative products', Oral presentation, Proceedings of 24th EU Photovoltaic Solar Energy Conference and Exhibition Hamburg.

Reinders, A., Borja, J.D., and Boer, A.D., 2011. 'Product-Integrated sustainable energy technologies - Six years of experience with innovation and sustainability', 4th World Conference on Design Research, Delft,

Reinders, A., and van Houten, F., 2006. 'Industrial design methods for product integrated PEM fuel cells', NHA Annual Hydrogen Conference.

Reinders, A., and van Houten, F., 2008. 'How innovation methods contribute to product design with PEM fuel cell technology for clean urban mobility', Proceedings of NHA Annual Hydrogen Conference Sacramento.

Reinders, A., Diehl, J.C., Brezet, H., (eds.) 2012. The power of design: Product innovation in sustainable energy technologies (pp. 1-138). John Wiley and Sons Ltd. UK.

Rhodes JD, Upshaw CR, Harris CB, Meehan CM, Walling DA, Navrátil PA, et al., 2014. Experimental and data collection methods for a large-scale smart grid deployment: methods and first results. *Energy* 2014; 65: 462–71.

Rich, C., Sidner, C.L., and Lesh, N.B., 2001. 'COLLAGEN: Applying Collaborative Discourse Theory to Human-Computer Interaction', *Artificial Intelligence Magazine*, Vol 22, Issue 4, pps 15-25.

Rijksoverheid, 2016. <https://www.rijksoverheid.nl/actueel/nieuws/2016/12/07/kabinet-schetst-route-naar-co2-arme-energievoorziening> Nieuwsbericht | 07-12-2016 | 08:30. Accessed March 3, 2017.

Rosenberg, N., 1976. *Perspectives on Technology*. Cambridge University Press.

Rutgers, B. and van den Belt, M., 2014. 'Consumption indicator', Master report 'Sources of Innovation', University of Twente.

Sanquist, T.F., Orr, H., Shui, B., Bittner, A.C., 2012. Lifestyle factors in U.S. residential electricity consumption. *Energy Policy*; 42: 354–364.

Sauter, R., Watson, J., 2007. Strategies for the deployment of microgeneration: implications for social acceptance. *Energy Policy* 35 (5), in press. doi:10.1016/j.enpol.2006.12.006.

Schot, J.W., Geels, F.W., 2008. Strategic niche management and sustainable innovation journeys: theory, findings, research agenda, and policy. *Technology Analysis and Strategic Management*, 20(5): 537–54.

Sociaal-Economische Raad (SER). <http://www.energieakkoordser.nl/energieakkoord.aspx>. Accessed February 2, 2017].

Son, Y.S., Moon, K.D. (2010) 'Home energy management system based on powerline

communication', In: Proceedings of the 28th international conference on consumer electronics (ICCE).

Steen, M., 2012. 'Human-Centered Design as a Fragile Encounter. Design Issues: Volume 28, Number 1, pp 72-80.

Stephens, J., Wilson, E., Peterson, T., Meadowcroft, J., 2013. Getting smart? Climate change and the electric grid. Challenges 4, 201–216.

Stern, P.C., 2014. Individual and household interactions with energy systems: Toward integrated understanding. Energy Research and Social Science 1, 41–48.

Ten Brink, I., Reints, R., Dijkhuis, J. (2014) 'Enerfree PLUG-IN: Smart Home Energy Management. Master report 'Sources of Innovation', University of Twente.

TexelEnergie, 2015. <http://www.texelenergie.nl/texel-slim-zelfvoorzienend/67/>. [Accessed January 27, 2015].

Thalen, J., Garde, J., 2013. Capturing use: user involvement and participatory design. In Bont, C.D., Ouden, E.D., Schifferstein, R., Smulders, F., & Voort, M.V.D., (Eds.), Advanced design methods for successful innovation (pp. 33-54). Den Haag: Design United.

The Royal Netherlands Meteorological Institute (KNMI). <http://projects.knmi.nl/klimatologie/dagegegevens/selectie.cgi>. [Accessed April 1, 2016].

The Royal Netherlands Meteorological Institute (KNMI). <https://weerstatistieken.nl/debilt/2014>. [Accessed April 2, 2016].

Toft, M.B., Schuitema, G., Thøgersen, J., 2014. The importance of framing for consumer acceptance of the Smart Grid : a comparative study of Denmark, Norway and Switzerland. Energy Res. Soc. Sci.;3: 113–23.

Top team energy in the Netherlands, 2012. Innovation contract smart grids. Headlines of a public private partnership and innovation agenda 2012.

United Nations Framework Convention on Climate Change (UNFCCC). http://unfccc.int/paris_agreement/items/9485.php. [Accessed April 1, 2017].

United States Census Bureau. <https://www.census.gov/content/dam/Census/library/publications/2015/demo/p60-252.pdf>. [Accessed April 28, 2016].

U.S. Climate Data. <http://www.usclimatedata.com/climate/austin/texas/united-states/ustx2742>. [Accessed March 31, 2016].

U.S. Energy Information Administration.
https://www.eia.gov/consumption/residential/reports/2009/state_briefs/pdf/TX.pdf.
[Accessed May 12, 2016].

U.S Energy Information Administration, 2016. International Energy Outlook 2016.
[https://www.eia.gov/outlooks/ieo/pdf/0484\(2016\).pdf](https://www.eia.gov/outlooks/ieo/pdf/0484(2016).pdf) [Accessed April 20, 2017].

Utrecht sustainability institute, 2014. <http://www.usi.nl/projecten/energie/smart-grid-rendement-voor-iedereen-2/>. [Accessed February 20, 2015].

U.S. Energy Information Administration.
<http://www.eia.gov/tools/faqs/faq.cfm?id=99&t=3>. [Accessed April 30, 2016].

Van Dam S.S., 2013. Smart energy management for households. Ph.D. Thesis Delft University of Technology.

Van Dam, S. S., Bakker, C. A. and Van Hal, J. D. M. 2010. Home energy monitors: impact over the medium-term. *Building Research and Information* 38 5:458-469. doi: 10.1080/09613218.2010.494832.

Van Dam, S. S., Bakker, C. A. and Van Hal, J. D. M. 2012. Insights into the design, use and implementation of home energy management systems. *Journal of Design Research* 10 1/2: 86-101.

Van der Laak, W.W.M., Raven, R.P.J.M., Verbong, G.P.J., 2007. Strategic niche management for biofuels: analysing past experiments for developing new biofuels policies. *Energy Policy* 35, 3213–3225.

Van der Linden A.C., Boerstra, A.C., Raue, A.K., Kurvers, S.R., Dear, R.J., 2006. Adaptive temperature limits: A new guideline in The Netherlands - A new approach for the assessment of building performance with respect to thermal indoor climate. *Energy and Buildings*; 38(1): 8-17.

Van Vliet, B., Chappells, H., Shove, E., 2005. *Infrastructures of Consumption: Environmental Innovation In The Utility Industries*. Earthscan, London.

Verbong, G.P.J., Beemsterboer, S., Sengers, F., 2012. Smart grids or smart users? Involving users in developing a low carbon electricity economy. *Energy Policy* 52, 117–125.

Von Hippel, E., 1988. *The Sources of Innovation*. Oxford University Press, New York.

Vringer, C.R., 2005. Analysis of the energy requirement for household consumption. PhD thesis University of Utrecht, Utrecht.

Vringer, K., Aalbers, T., Blok, K., 2007. Household energy requirement and value patterns. *Energy Policy*; 35(1): 553-566.

Western Regional Climate Center USA. http://www.wrcc.dri.edu/cgi-bin/wea_graph2.pl?stn=tsau&mon=01&yea=14&day=1&ndy=031&graphset=M&image size=2&scale=A&xmark=N&pcodes=RAD&unit=E. [Accessed April 17, 2016].

Wever, R., van Kuijk, J., Boks, C., 2008. User-centred Design for sustainable Behaviour. *International Journal of Sustainable Engineering* Vol. 1, No. 1, 2008.

Wolsink, M., 2011. Wind power: the basic challenge concerning social acceptance. In: Meyers RE, editor. *Encyclopedia of environmental science and technology*. Berlin: Springer.

Wolsink, M., 2012. The research agenda on social acceptance of distributed generation in smart grids: Renewable as common pool resources. *Renewable and Sustainable Energy Reviews* 16, 822– 835.

Young, C.K., Sönmez, G., and van Doorn, R., 2014. 'Design of a Home Energy Manager. Master report 'Sources of Innovation', University of Twente.

Zhou, B., Li, W., Chan, K.W., Cao, Y., Kuang, Y., and Liu, X., 2016. 'Smart home energy management systems: Concept, configurations, and scheduling strategies', *Renewable and Sustainable Energy Reviews*, 61, 30–40.

Appendices

Appendix A. Data tables of electricity meter readings for Pecan Street and PowerMatching City

This appendix presents the total average monthly electricity data (use, grid consumption from the grid, and generation) of households in the Pecan Street and PowerMatching City pilot projects, which have been evaluated in Chapter 4.

A1. Total average electricity use, consumption from the grid and generation of 85 single-family households in Pecan Street smart grid pilot in 2013 and 2014

Month (2013)	Electricity (kWh)		
	Used	Grid	Generated
January	564.7	207.6	369.6
February	451.3	-2.4	468.0
March	502.9	-62.8	583.5
April	524.4	37.1	502.7
May	761.7	219.5	559.8
June	1127.9	515.0	633.2
July	1162.1	556.6	625.0
August	1305.2	682.1	642.7
September	1091.4	558.5	548.6
October	714.7	229.1	499.8
November	549.5	202.2	359.9
December	652.7	318.7	346.6

Month (2014)	Electricity (kWh)		
	Used	Grid	Generated
January	625.0	180.7	463.9
February	551.1	176.8	399.0
March	576.4	36.0	572.3
April	656.8	73.1	616.3
May	878.9	243.4	673.4
June	1225.8	574.8	688.5
July	1366.2	659.1	749.1
August	1521.3	801.2	762.8
September	1178.6	629.6	583.8
October	902.4	308.0	632.0
November	596.6	185.2	434.8
December	677.6	422.2	271.3

A2. Total average electricity use, consumption from the grid and generation of 21 single-family households in PowerMatching City smart grid pilot in 2013 and 2014

Month (2013)	Electricity (kWh)		
	Used	Grid	Generated
January	216.2	168.0	47.6
February	260.5	182.0	77.6
March	283.6	191.0	93.0
April	241.3	128.1	113.3
May	259.9	158.0	102.0
June	208.1	78.0	129.9
July	177.6	51.0	127.2
August	178.6	43.0	136.0
September	201.1	108.0	93.3
October	199.7	146.0	54.4
November	200.3	153.0	47.3
December	228.7	164.5	64.2

Month (2014)	Electricity (kWh)		
	Used	Grid	Generated
January	243.3	168.0	74.5
February	197.2	132.2	64.8
March	245.2	145.0	100.5
April	236.1	157.3	78.8
May	224.9	141.0	84.5
June	201.3	89.0	112.3
July	175.6	17.0	158.7
August	203.4	49.0	154.0
September	179.3	58.0	121.5
October	192.5	107.0	86.1
November	182.3	99.0	82.7
December	209.3	134.0	75.3

Appendix B. Interview topic guide with smart grid stakeholders

This appendix presents the interview questions used to explore the insights of 9 smart grid stakeholders regarding the development and performance of residential smart grid pilot projects, which are discussed in Chapter 3.

I. Project set-up

- 1) How was the process of setting up these pilot projects organized?
- 2) How long did it take to plan and realize this pilot with the various households and other stakeholders?
- 3) What is the estimated cost of setting up the pilots, and how is it funded?
- 4) What are the major expenditures involved in setting up this project?

II. Stakeholder Involvement

- 5) Who are the stakeholders involved in Smart Grids development and implementation at the local level (households and neighborhoods)?
- 6) Who are the principal stakeholders?
- 7) How is the engagement/interaction between the various stakeholders structured?
- 8) At what stage of the process were the various stakeholders involved?
- 9) Looking back at the project, do you think that particular stakeholders needed to have been earlier involved or later involved in the process?
- 10) What are the roles of the different stakeholders in the setting up and implementation of the project?
- 11) Do the roles need to be redefined?
- 12) What are the potential future roles for these stakeholders, and how can this help in implementing future smart grids?

III. Products and Services design and development

- 13) What products and services currently exist, and what are the different functionalities of these products and services?
- 14) How is the process of developing new products and services currently organized?
- 15) What are the potential Smart Grid products and services at the end-user level, and what functions are they expected to perform?
- 16) What is the current role of end-users and other stakeholders in the development of products and services?
- 17) What are the current and future demands of these stakeholders with regards to product and service development?

- 18) How can the demands of the relevant stakeholders be better incorporated in the design and development of these products and services?
- 19) Has the full potential of the currently developed products and services been realized?
- 20) How can these functionalities be better aligned to the demands of the end-users as well the energy companies and other stakeholders?
- 21) Do any of the elements of the current products and services need to be improved or redesigned?
- 22) What are the existing design approaches used in developing these products and services?

IV. End users

Various studies stress that an active involvement of residential end-users will help to contribute to valuable insights for the development of smart grids products and services. In what ways are end-users currently involved in the development of product and service ideas?

- 23) How can end-user engagement help in the development of new innovative product and service systems?
- 24) What is the value perceived by the end-user? How does the client/end-user interact with the offered system?
- 25) How can current smart grid products and services be improved in order to support the active involvement of end-users?
- 26) How can the development of future smart grid products and services that will support end-users be structured and developed?
- 27) How can products and services be aligned with end-user demand and requirements?
- 28) What new services are currently available, and how are these possibilities utilized in practice by end-users?
- 29) To what extent have these products and services enabled end-users to take control of their energy use and generation options?
- 30) What are the end-user expectations with regards to the development of new products and services?

Local energy generation and use

- 31) What are the necessary functionalities (products and services) that could help to increase local energy generation?
- 32) How can local/low voltage smart grids, products and services potentially help to provide these functionalities?
- 33) What products and services related to local smart grids currently exist, and what are the different functionalities of these products and services?
- 34) What potential products and services could facilitate the effective development and implementation of local smart grids?
- 35) What products and services enable end-users to Freely and fully exchange electricity

Appendix C. Questionnaire survey for evaluation of Home Energy Management Products

This appendix presents the set-up of the questionnaire survey for the evaluation of Home Energy Management products discussed in Chapter 5.

Questionnaire

New products for smart energy households

Dear participant,

I would like to invite you to participate in this questionnaire about your opinion and interest in new smart energy products for use in Dutch households.

Filling out this questionnaire will take approximately 10 to 15 minutes. Your answers will be handled confidentially, and will not be shared.

This survey is conducted as part of my PhD research on the use and acceptance of new energy products and services for smart energy homes. The purpose of this questionnaire is to explore the opinion of end users with regards to both existing commercial smart energy products and new product concepts for households that are not yet in the market. Your opinion is important because it will support the development of new smart energy products that meet the wishes and needs of consumers.

If you have further questions about this survey, please contact us. This survey has been approved by my supervisors Prof. dr. Angele Reinders, dr.ir. Peter Joore, en dr.ir. Linda Wauben.

Thank you for filling out this survey.

Sincerely,

Uchechi Obinna

PhD Researcher

Faculty of Industrial Design, TU Delft.

u.p.obinna@tudelft.nl

Prof. dr. Angele Reinders: A.H.M.E.Reinders@utwente.nl

Dr. ir. Peter Joore: Peter.Joore@nhl.nl

Dr. ir. Linda Wauben: I.s.g.l.wauben@hr.nl

Instructions

- Three types of energy products that can support the usage and control of household energy are presented in this questionnaire. They include: smart thermostats, smart plugs, and smart wall sockets
- A brief description of each product, and their main functionalities will be given
- Read the instructions carefully, in order to fill out the questionnaire as effective as possible

Questions

Part I. General Information

- 1) Sex?
 - Male
 - Female
- 2) What is your age?
 - < 20 years
 - 20-35
 - 35 – 45
 - 46 and older
- 3) How many persons live in your house?
 - 1
 - 2
 - 3
 - 4
 - 5 or more
- 4) What is your highest level of education?
 - High school diploma with advanced classes
 - Bachelor of applied science
 - University and higher
 - Others, namely...
- 5) What type of house do you live in?

- Terraced house
- Detached house
- Semi-detached house
- Apartment / flat
- Others, namely.....

Part II. Product concept evaluation

Three types of commercially available smart energy products are presented in this section. Smart energy products could support the monitoring, display and control energy use in households, thereby improving home energy efficiency. Examples of smart energy products are: smart plugs, in-home displays and smart washing machines.

6) Do you have smart energy products in your home?

- Yes
- No
- I don't know

7) If yes, which smart energy products do you have in your house?



.....

8) If no, what is the reason?

- Not familiar with these products
- Not interested in these products
- Too expensive
- Too complex
- Others, namely.....

A. Existing products

Three different smart energy products are presented: A smart thermostat, a smart plug and a smart wall socket.

Products	Features and attributes
<p>Product A. Smart thermostat</p> 	<ul style="list-style-type: none"> i. Gives insight in energy use, generation, and energy costs of household appliances ii. Connected appliances could be switched on and off from a distance with a smart phone iii. Displays the energy use in households and the average use in the neighbourhood
<p>Product B. Smart plug</p> 	<ul style="list-style-type: none"> i. Gives insight in energy use and costs of household appliances ii. Possesses illuminating LED-rings that changes colour based on the energy consumption. The light flashes when the maximum load (2,5 kW) is exceeded iii. Connected appliances could be switched on and off from a distance with a smart phone
<p>Product C. Smart wall socket</p> 	<ul style="list-style-type: none"> i. Remote control on a smart phone ii. Possibility to set timetables for setting the smart plug on and off iii. Measures the power consumption of connected devices

9) On a scale of 1 to 5, indicate what you think of the products displayed above.

	1 Very unattractive	2 Unattractive	3 Neutral	4 Attractive	5 Very attractive
Product A: Smart thermostat	<input type="radio"/>	<input type="radio"/>	<input type="radio"/>	<input type="radio"/>	<input type="radio"/>
Product B: Smart plug	<input type="radio"/>	<input type="radio"/>	<input type="radio"/>	<input type="radio"/>	<input type="radio"/>
Product C: Smart wall socket	<input type="radio"/>	<input type="radio"/>	<input type="radio"/>	<input type="radio"/>	<input type="radio"/>

10) Which is your favourite product?

- Product A
- Product B
- Product C

11) Which features do you find attractive in your chosen product? *Multiple answers are possible*

- Appearance
- Manual control
- Visual display of energy information
- Remote control
- Expected ease of use
- Energy comparison with other households
- Energy monitoring of appliances
- Others, namely.....

12) Which other features would you like to have in your chosen product?

.....

13) In your opinion, which of the three products best stimulates energy efficiency?

- Concept A
- Concept B
- Concept C

14) What is the reason for your answer?



.....

15) On a scale of 1 to 5, how likely is it that you acquire your chosen product?

Very unlikely Unlikely Neutral Likely Very likely
○ ○ ○ ○ ○

B. New product concepts

In this section, three different smart energy product concepts are presented: a smart thermostat, a smart plug and a smart wall socket.

Concepts	Features/attributes
<p>Concept A. Smart thermostat</p> 	<ul style="list-style-type: none"> i. Displays feedback on energy use (water gas use; history of energy use and cost savings in Wh, €/hr; energy usage of other households via a manually controlled projector ii. Wireless communication module that provides communication between the device and appliances or control devices iii. Battery/transformer module for power supply Controlled through applications on mobile devices
<p>Concept B. Smart plug</p> 	<ul style="list-style-type: none"> i. Communicate with a user interface e.g. smart phone application with a wireless module to display energy information ii. Provides information about energy availability, prices using colour indicators (Green: energy abundance/cheap price, Blue: equal demand and supply/standard price, Red: scarcity/high price) iii. An energy unit monitors energy consumption of devices iv. Manually switched on and off by the user

Concept C. Smart wall socket



- i. Provides information about current energy situation and prices through LED indicators (green light= lower energy prices, red light=higher energy prices)
- ii. Contains replaceable batteries that store energy during off peak hours
- iii. Possibility to stack devices on top of each other to increase storage capacity
- iv. Mobile energy and remote use: device can be carried around

16) On a scale of 1 to 5, indicate what you think of the products displayed above.

	1 Very unattractive	2 Unattractive	3 Neutral	4 Attractive	5 Very attractive
Concept A	<input type="radio"/>	<input type="radio"/>	<input type="radio"/>	<input type="radio"/>	<input type="radio"/>
Concept B	<input type="radio"/>	<input type="radio"/>	<input type="radio"/>	<input type="radio"/>	<input type="radio"/>
Concept C	<input type="radio"/>	<input type="radio"/>	<input type="radio"/>	<input type="radio"/>	<input type="radio"/>

17) Which is your favourite concept?

- Concept A
- Concept B
- Concept C

18) Which features do you find attractive in your chosen product? *Multiple answers are possible*

- Appearance
- Manual control
- Visual display of energy information
- Remote control

- Expected ease of use
- Energy comparison with other households
- Energy monitoring of appliances
- Others, namely.....

19) Which other features would you like to have in your chosen product?

.....

20) On a scale of 1 to 5, how likely is it that you acquire your chosen product?

Very unlikely Unlikely Neutral Likely Very likely

21) What is the reason for your answer?

.....

22) Do you have any further remarks or ideas regarding smart energy products?

.....

Thank you for filling out this questionnaire!

Appendix D. Numeric results of questionnaire survey analyzed

This appendix presents numeric results of the most preferred Home Energy Management products, which are discussed in Chapter 5.

Existing products

Respondents	Existing Products		
	Favourite product	Reason for preference	Most liked features
1	Smart thermostat	The thermostat shows the entire household energy use	Visual presentation of energy information, Remote control, Energy monitoring of appliances
2	Smart thermostat	Shows total energy use in the house	Expected ease of use, Energy comparison with other households, energy monitoring of my appliances
3	Smart plug	Intuitive design	Expected ease of use, Visual presentation of energy information, appearance
4	Smart thermostat	Gives insight into the usage of most energy-using appliances	Visual presentation of energy information, Energy monitoring of appliances
5	Smart thermostat		Visual presentation of energy information, Energy comparison with other households, energy monitoring of my appliances
6	Smart thermostat		Manual control
7	Smart thermostat	Gives total insight in energy use	Energy monitoring of my appliances
8	Smart plug	Continuous insight in energy use best stimulates energy efficiency	Visual display of energy information
9	Smart thermostat		Visual presentation of energy information, Energy comparison with other households, energy monitoring of my appliances
10	Smart thermostat	Gives total insight in energy use of all appliances, remote control. It is also a nice thing on the wall	Appearance, Visual display of energy information, remote control, Energy comparison with other households, energy monitoring of my appliances
11	Smart thermostat	I find it the most interesting compared to the smart plug and wall socket	Remote control
12	Smart thermostat	The use of colours easily triggers someone	Visual display of energy information, expected ease of use
13	Smart thermostat	The concept shows a good overview on the wall and compares with the the neighbour. This creates a sort of peer-pressure.	Visual display of energy information, expected ease of use, Remote control, Energy comparison with other households
14	Smart thermostat	The other concepts are part solutions with limited added value	Visual display of energy information, Energy comparison with other households
15	Smart plug		Visual display of energy information, expected ease of use, energy monitoring of my appliances
16	Smart thermostat	Total feedback and insight in energy use	Expected ease of use, Remote control, energy monitoring of my appliances
17	Smart thermostat		Visual display of energy information, expected ease of use, Remote control
18	Smart wall socket	Biggest impact on energy use	Visual display of energy information, expected ease of use, energy monitoring of my appliances
19	Smart thermostat		Energy monitoring of my appliances
20	Smart thermostat		Energy monitoring of my appliances

21	Smart thermostat		Appearance, Visual display of energy information
22	Smart thermostat	I always forget to switch off the heating. The chosen concept offers the possibility to change the settings if my plan changes (eg if i arrive home earlier or later than planned)	Remote control, Expected ease of use
23	Smart thermostat	Can be used for various appliances.	Visual display of energy information
24	Smart plug	Thermostats don't work with heatpumps and floor heatings. Smart wall sockets only stay at a point, plugs could be used for many purposes.	Remote control
25	Smart thermostat	Competition with the rest of the neighbourhood	Visual display of energy information, Remote control, Energy comparison with other households
26	Smart thermostat	Supports the usage of many appliances at the same time (thus, only more that heating systems alone).	Visual display of energy information, expected ease of use, Remote control, Energy monitoring of my appliances
27	Smart wall socket	Remote reading of power consumption and switching / remote programming of all devices in the home	Remote control, Energy monitoring of my appliances
28	Smart wall socket	Gives much more signals (led-light colour)	Appearance, Visual display of energy information, expected ease of use
29	Smart thermostat		Visual display of energy information
30	Smart thermostat	This gives the most insight with the least effort. Plug is not attractive, if you have a lot of sockets at home for example.	Visual display of energy information, remote control, Energy monitoring of my appliances
31	Smart thermostat	Because you can really put devices on it.	Appearance, Visual display of energy information, remote control, Energy comparison with other households
32	Smart thermostat	It provides the best option to reduce energy costs	Visual display of energy information, remote control
33	Smart thermostat	For me, the smart thermostat creates better understanding / awareness of gas consumption. This is the biggest for me, especially because heat is the major part of energy consumption	Energy comparison with other households
34	Smart plug	This allows you to compare with the neighbors and is most complete. There is a display on the device, so you do not need any other device for reading, therefore low-threshold and it's a device you need (a thermostat)	Remote control, Energy monitoring of appliances
35	Smart thermostat	One solution in one is the most user-friendly.	Appearance, Manual control, Visual display of energy information, expected ease of use
36	Smart wall socket		Remote control
37	Smart wall socket	Visual feedback and autonomy	Appearance, visual display of energy information, manual control, energy monitoring of my appliances
38	Smart thermostat	Everything immediately visible	Visual display of energy information, Automatic control
39	Smart thermostat	B en C te veel op detailniveau	Expected ease of use
40	Smart thermostat	The smart plug and smart wall socket are too much on the detail level	Visual display of energy information, expected ease of use, Remote control

41	Smart thermostat	My energy consumption consists (mostly) of gas and with a clever thermostat, I can optimize my consumption better.	Visual display of energy information, Remote control
42	Smart thermostat	Gathers the data of all energy carriers. This makes it possible to choose to prioritize energy consumers and their replacement.	Appearance, Visual display of energy information, remote control, Energy monitoring of my appliances, Expected ease of use
43	Smart thermostat	Gas consumption is the most profitable, power is too cheap to justify many of these devices for energy saving. Comfort will also be a major driving force. Thus the smart thermostat appears to be the most ideal.	Energy monitoring of my appliances
44	Smart thermostat	This works for all devices, the other works for one device at a time	Energy monitoring of my appliances
45	Smart thermostat	Information about energy use is very welcome to me	Visual display of energy information, Energy comparison with other households, Energy monitoring of my appliances
46	Smart plug	It instantly makes you aware of the amount of energy you consume without having to scroll through menus or get your smartphone. In addition, you can see through the light that power is being consumed and do not forget to unplug devices that are already charged (such as phones)	Visual presentation of energy information, Energy monitoring of appliances
47	Smart plug	There is a timer. But it's still better to get devices that you do not use from the wall outlet. Even safer too!	Manual control
48	Smart thermostat	Can control electric appliances	Visual presentation of energy information, Energy monitoring of appliances
49	Smart wall socket		Expected ease of use, Remote control
50	Smart wall socket	Allows you to monitor all connected devices. Plug is too cumbersome, thermostat is limited to heating	Manual control, Expected ease of use, energy monitoring of my appliances
51	Smart plug		Remote control, Energy monitoring of my appliances
52	Smart thermostat	I expect less impact from smart plugs and sockets because I do not regularly monitor or adjust the data they provide. (I sometimes suffer from info stress through my phone)	Visual display of energy information, expected ease of use, Remote control, Energy monitoring of my appliances
53	Smart thermostat		Visual display of energy information
54	Smart thermostat	Gives insight into total energy use	Visual presentation of energy information, Energy comparison with other households, energy monitoring of my appliances
55	Smart plug		Expected ease of use, Energy comparison with other households, energy monitoring of my appliances
56	Smart thermostat		Manual control, energy monitoring of my appliances, Visual display of energy information
57	Smart thermostat	Possibility to display a lot of information in a clear way.	Visual display of energy information, energy monitoring of my appliances
58	Smart thermostat		Expected ease of use, energy monitoring of my appliances
59	Smart thermostat	Overview of many appliances	Remote control, Energy monitoring of my appliances, Expected ease of use
60	Smart thermostat		Manual control, expected ease of use, Expected ease of use, Remote control

61	Smart thermostat	Because you have an overview of all your devices, and can see what uses the most energy. Because it pays to see that device if it can be more economical	Expected ease of use
62	Smart wall socket	In most households this has the greatest consumption	Visual presentation of energy information,Energy comparison with other households,energy monitoring of my appliances,remote control
63	Smart thermostat		Remote control, Energy monitoring of my appliances,Energy comparison with other households
64	Smart thermostat	Insight in energy use of the individual appliances	Visual display of energy information,remote control
65	Smart thermostat	Because it concerns both the appliances and energy consumption of heating.	Remote control, Energy monitoring of my appliances,Energy comparison with other households
66	Smart wall socket	Own initiative is the most realized.	Manual control,energy monitoring of my appliances, remote control
67	Smart wall socket	Signal function	Expected ease of use
68	Smart thermostat	The smart thermostat is best for understanding the entire energy consumption	Manual control, expected ease of use, remote control, visual display of energy information
69	Smart plug	Heating is the most expensive element	Manual control, expected ease of use
70	Smart thermostat	Remote device control, notifications for typical usage.	Visual display of energy information,expected ease of use,Remote control
71	Smart thermostat	We have had a smart thermostat for 2 years, which has saved us a lot of energy. The energy bill has gone down quite a bit.	Remote control, Energy monitoring of my appliances,Expected ease of use
72	Smart thermostat	Social comparison	Visual display of energy information,Energy comparison with other households,Energy monitoring of my appliances
73	Smart plug	The indicative light appears very effective to me	Appearance, Visual display of energy information, remote control
74	Smart thermostat	Data visualization	Visual display of energy information,Remote control, expected ease of use
75	Smart thermostat		Remote control
76	Smart wall socket		Remote control
77	Smart thermostat		Remote control, Energy monitoring of my appliances,Expected ease of use
78	Smart wall socket		Energy monitoring of my appliances
79	Smart thermostat		Appearance, Manual control, Visual display of energy information,expected ease of use,remote control
80	Smart plug	Easily implemented	Energy monitoring of my appliances
81	Smart wall socket	Direct feedback	Manual control,energy monitoring of my appliances,Visual display of energy information
82	Smart wall socket	Displays energy use per appliance (the one that uses the most energy)	Remote control, Energy monitoring of appliances
84	Smart thermostat		Expected ease of use
85	Smart wall socket	Offers the most possibility to save energy	Remote control, Energy monitoring of appliances
86	Smart thermostat		Visual presentation of energy information, Remote control, Energy monitoring of appliances
87	Smart thermostat		Expected ease of use

Conceptual products

Respondents	Conceptual products		
	Favourite product	Reason for preference	Most liked features
1	Smart plug	Small and practical product	Energy monitoring of appliances
2	Smart thermostat		Visual presentation of energy information, perceived ease of use, Energy monitoring of appliances
3			Expected ease of use
4			Energy monitoring of appliances
5			Energy monitoring of appliances, energy comparison with other households
6			Visual presentation of energy information
7			Energy monitoring of appliances, energy comparison with other households
8	Smart wall socket	I want to be more energy efficient	Visual presentation of energy information
9	Smart thermostat		Visual presentation of energy information, Energy comparison with other households
10	Smart thermostat	Beautiful thing, small	Appearance, Visual display of energy information, expected ease of use, Energy comparison with other households, energy monitoring of my appliances
11	Smart thermostat		Visual presentation of energy information, Remote control
12	Smart plug	Appearance	Appearance, Visual display of energy information
13	Smart thermostat	Given that the future lies with efficient energy use to save both costs and the environment	Appearance, Visual display of energy information, Energy comparison with other households, energy monitoring of my appliances
14	Smart thermostat	Awareness, saving and smart control of sustainable energy	Visual display of energy information, Energy comparison with other households
15	Smart wall socket		Visual display of energy information, expected ease of use, energy monitoring of my appliances
16			
17	Smart thermostat		Visual display of energy information, expected ease of use, Remote control
18	Smart thermostat	Excessive known information that in this way fast ,that become bundled information. We already have so much information	Visual display of energy information, expected ease of use, energy monitoring of my appliances
19	Smart thermostat		energy monitoring of my appliances
20	Smart thermostat		Energy monitoring of appliances
21	Smart thermostat		Manual control, visual display of energy information
22	Smart thermostat	Design	Remote control
23	Smart plug	Gadget	Remote control
24	Smart plug	Appearance (handy)	Remote control
25			
26	Smart thermostat		Manual control, Remote control, expected ease of use, energy monitoring of appliances
27			
28	Smart wall socket	Energy storage possibilities	Energy monitoring of appliances

29	Smart thermostat		Expected ease of use
30	Smart thermostat	Looks attractive and user-friendly	Appearance, Visual display of energy information, expected ease of use
31	Smart thermostat	Good to understand energy consumption (per device) and thus save (trias energetics)	Appearance, Visual display of energy information, expected ease of use, energy monitoring of my appliances
32	Smart thermostat	More interesting for families with high energy use	Appearance, remote control, energy monitoring of my appliances
33			
34	Smart wall socket	The storage of energy is an interesting option	Expected ease of use
35	Smart thermostat		Appearance, Manual control, Visual display of energy information, expected ease of use
36	Smart plug		Appearance
37	Smart wall socket	Experimenting with energy use and not use	Appearance, visual display of energy information, manual control, Other....mobile
38			
39	Smart thermostat		Expected ease of use
40	Smart thermostat		Remote control, expected ease of use
41	Smart thermostat	Could reduce energy consumption compared to existing thermostat	Visual display of energy information, expected ease of use, Remote control
42	Smart wall socket		
43	Smart wall socket	I am convinced that we will use this kind of product in the future	Energy monitoring of appliances
44	Smart plug		Appearance
45	Smart thermostat	I want to invest in energy saving	Visual display of energy information, Energy comparison with other households, Energy monitoring of my appliances
46	Smart wall socket		Manual control, visual display of energy information, Expected ease of use
47	Smart plug		Manual control
48	Smart plug	Helps to save energy	Energy monitoring of appliances
49	Smart wall socket		Expected ease of use
50	Smart wall socket	Storage of power in power outlet limited power energy reduction (at least if self-generated energy can be stored, for example, from PVC panels).	Visual display of energy information, expected ease of use, energy monitoring of my appliances, Remote control
51	Smart plug		Appearance, Remote control
52	Smart thermostat		Visual display of energy information, energy monitoring of my appliances, Remote control
53	Smart thermostat		Visual presentation of energy information
54	Smart thermostat		Visual presentation of energy information, Energy comparison with other households, energy monitoring of my appliances
55	Smart plug		Manual control
56	Smart wall socket		Energy monitoring of appliances, Expected ease of use
57	Smart thermostat	Attractive concept	Energy monitoring of appliances
58	Smart thermostat		Energy monitoring of appliances, energy comparison with other households
59	Smart wall socket		Manual control, Remote control, energy monitoring of appliances, visual display of energy information
60	Smart plug		Visual presentation of energy information, perceived ease of use
61	Smart thermostat		Energy monitoring of appliances
62	Smart thermostat		Expected ease of use, energy comparison with other households

63	Smart thermostat		
64	Smart thermostat	I believe in small-scale sharing	Visual presentation of energy information, Remote control
65	Smart plug		Visual presentation of energy information
66	Smart wall socket		Energy monitoring of appliances, energy comparison with other households
67	Smart plug	Use of common sense	Expected ease of use
68	Smart plug	Appears attractive	Appearance, Visual display of energy information
69	Smart thermostat	Better supports energy saving	Visual display of energy information, expected ease of use
70	Smart thermostat	More grip on energy consumption	Visual presentation of energy information, perceived ease of use, Energy monitoring of appliances
71	Smart wall socket	It can also be used in other places where no electricity is used.	Energy monitoring of appliances, Expected ease of use
72	Smart thermostat		Visual display of energy information, expected ease of use
73	Smart thermostat		Appearance, Visual display of energy information, expected ease of use
74	Smart plug		Visual display of energy information, Remote control
75	Smart thermostat		
76	Smart wall socket		
77	Smart thermostat		
78	Smart wall socket		
79	Smart wall socket		Manual control
80	Smart plug		
81	Smart wall socket		
82	Smart wall socket		Energy monitoring of appliances, Expected ease of use, remote control
84	Smart thermostat		
85	Smart wall socket		Remote control
86	Smart thermostat		
87	Smart thermostat		

Appendix E. Product concepts for HEMS designed by students in 2013

This appendix presents some of the product concepts that have been developed by students in the course Sources of Innovation in 2013, which are discussed in Chapter 5.

Product concepts designed in 2013



Figure E1. Smart Energy planner that provides insight in energy availability and energy use of devices.

Designers: Hans Blankenvoort and Mike broekman.



Figure E2. Innovative shower with digital application that supports the use of less hot water and energy.

Designers: Karlo Finker and Pim Spoor.



Figure E3. Budget power plug and basic control unit that informs user about energy usage. Designers: Jeroen Labots and Ruben Kruiper.



Figure E4. A smart wall socket, a hand-held device, and wireless data transmission station which provides information about current energy consumption and prices. Designers: Henk de Weerd and Frank Heus.

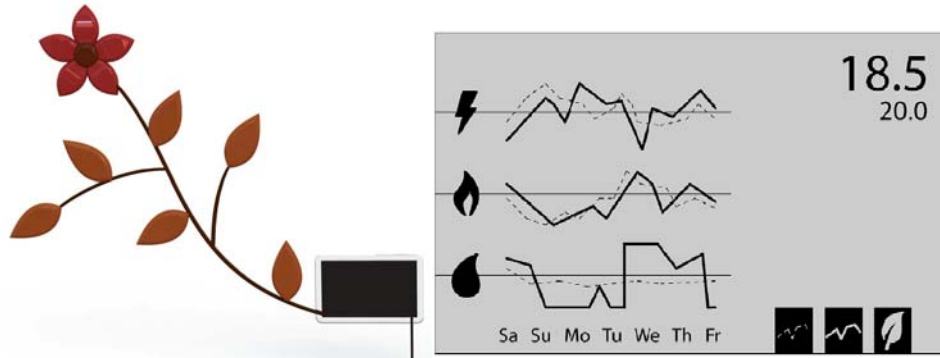

Figure E5. Smart energy meter that visually communicates the power consumption to the end-user.

Designers: Rens ten Klooster, Daphne Laméris.



Figure E6. Smart energy planner which gives insight in power consumption

Designers: Jannes Lohmeijer and Tom Vrugteveen



Figure E7. Smart power strip that gives insight in energy use.

Designers: Mart Rozema and Rik Taatgen.



Figure E8. A Smart plug that enables automatic and smart charging of small household appliances with internal batteries as buffer devices.
Designers: Elena findeisen and Willem Haanstra



Figure E9. Energy storage system (Usmart) that Stores energy during off-peak hours.
Designers: Barbara van de Sande and Eva Hofland



Figure E10. An In-home display (Reduse) that gives visual insight into energy use in households.

Designers: Heleen de Vos and Thomas den Hengst.



*Figure E11. Smart refrigerator and a mobile application that supports the reduction of energy use by adjusting to peaks in energy network.
Designers: Bram van Wijk and Robbert Bakker.*



Figure E12. Smart lavatory system that supports the creation of awareness concerning energy and water usage.

Designers: Jeroen van Beek Thijs Weggemans.

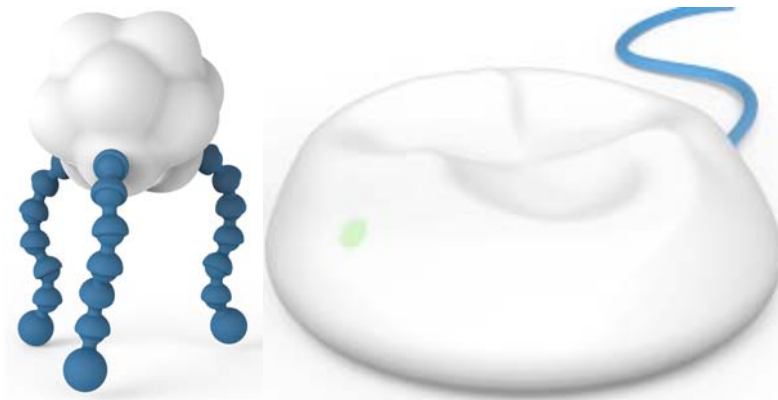

Figure E13. An innovative lighting product (Light bubble) and a charging platform that supports efficient use of lighting in households.

Designers: Marleen Offringa and Anke Sesink.

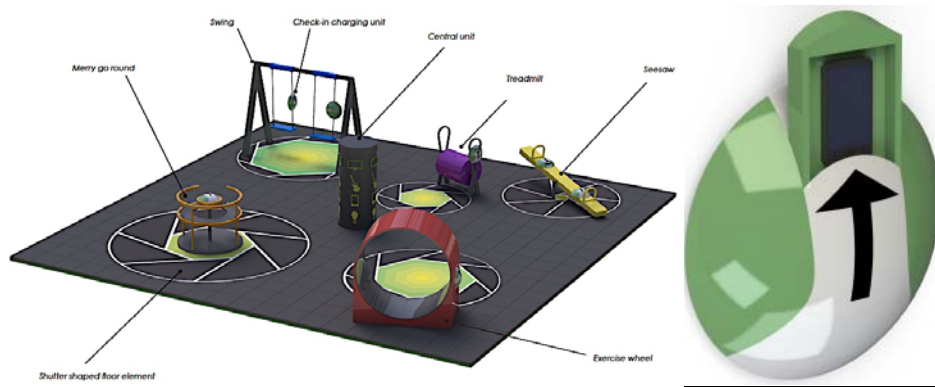
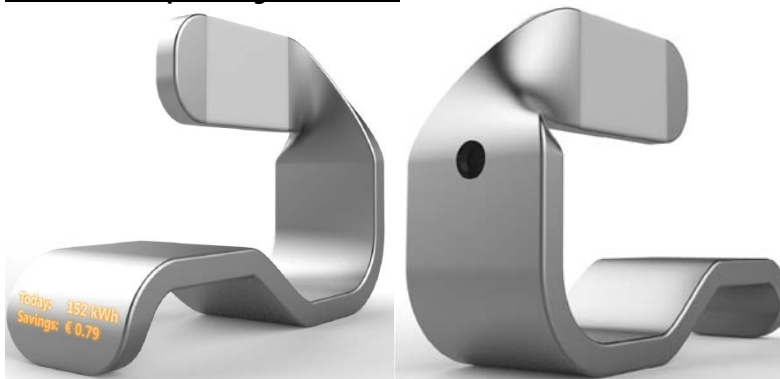

Figure E.15. Smart energy playground with check-in and charging unit that creates energy awareness and promotes energy efficiency.
 Designers: Berber Y. Vos and Liza Boon



Figure E15. A Smart wall socket (incubator) that communicates the current energy supply situation to the end-user.
 Designers: Job Bergsma & Martin Binnema

Product concepts designed in 2014



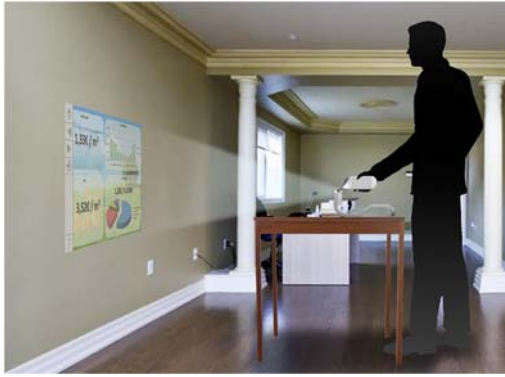

Figure E16. A home energy manager that informs about energy demand, supply and savings.

Designers: Chee-Kent Yong, Gökhan Sönmez, Rowan van Doorn

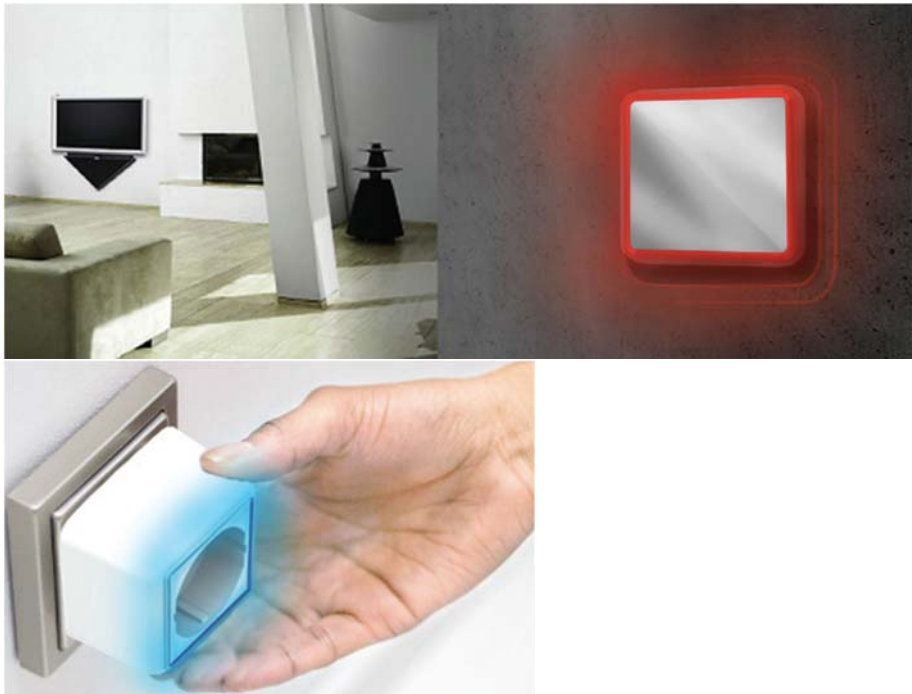

Figure E17. Presence detector and switch plug that makes end-users aware of energy consumption.

Designers: Dennis de Lange, Emmy Spikkert



Figure E18. Consumption Indicator that stimulates energy consciousness in households.
Designers: Bernd Rutgers, Mieke van den Belt



Figure E19. Energy Tracking platform that tracks and displays energy consumption.
Designers: T. van der Linden, H. Waasdorp.



Figure E20. A home energy buddy and a mobile application that creates awareness of energy usage.

Designers: Ruben van der Hout and Ellis Wiggers



Figure E21. An energy management system that shows the energy situation of buildings.

Designers: Judith Vissers and Ackelien Hageman



Figure E22. Electric vehicle power station with user interface that supports smart charging of electric vehicles and peak reduction in electricity use.
Designers: Mattijs Stam and Abel Gerrits

About the author



Uchechi Paddy Obinna was born on August 12th, 1978 in Owerri, Imo state, Nigeria. He obtained a Bachelor of Technology degree in Food Science and Technology from the Federal University of Technology Owerri in 2002.

In his quest for further study abroad, he enrolled at the Van Hall University of Applied Sciences (part of University of Wageningen) in Leeuwarden in 2005, and obtained a Bachelors degree in Environmental Sciences in 2007. He also holds a Master's degree in Environmental and Energy management (University of Twente, 2009).

Prior to starting his PhD research, he worked as a project researcher at the sustainable innovations programme of the Province of Fryslân, the Netherlands. His activities at the province focused on research and consultations with various governmental and private parties aimed at making public buildings more sustainable.

He started his PhD at the department of Industrial Design Engineering of Delft University of Technology in 2012, where his research focused on evaluation of the development and performance of residential Smart Grid projects.

During his PhD, he also took part in the EU Erasmus plus project *Smart City Coaching (SMACC)* as facilitator of various co-creation workshops in the context of Smart Cities.

Uchechi currently works as a researcher and lecturer in Environmental Economics with the Coastal and Marine Resources department of the Van Hall Larenstein University of Applied Sciences in Leeuwarden (His Alma mater).
Uchechi loves reading, travelling, fitness activities and cooking.

Publications

1. Insights from stakeholders of five residential Smart Grid pilot projects in the Netherlands (Uchechi Obinna, Peter Joore, Linda Wauben, Angele Reinders). *Smart Grid and Renewable Energy*, 2016, 7, 1-15.
<http://dx.doi.org/10.4236/sgre.2016.71001>.
2. Comparison of two residential Smart Grid pilots in the Netherlands and the USA with a focus on energy performance and user experiences. (Uchechi Obinna, Peter Joore, Linda Wauben, Angele Reinders). *Applied Energy* 191 (2017) 264–275.
3. Preferred Attributes of Home Energy Management Products for Smart Grids – Results of a design study and related user survey (Uchechi Obinna, Peter Joore, Linda Wauben, Angele Reinders). *Journal of design research* (under review).
4. Water related sustainable innovations and the Smart Grid (Uchechi Obinna, Peter Joore, Linda Wauben, Angele Reinders). In proceedings of the 16th European Roundtable on Sustainable Consumption and Production (16th ERSCP), 2013, June 4 – 7, Istanbul, Turkey.
5. Smart energy households' pilot projects in The Netherlands with a design-driven approach (Daphne Geelen, Arno Scheepens, Charlotte Kobus, Uchechi Obinna Ruth Mugge, Jan Schoormans, Angele Reinders). Presented at the 4th IEEE PES Innovative Smart Grid Technologies Europe (ISGT Europe) conference, October 6-9 2013, Copenhagen Denmark.
6. Sustainable development of energy products for smart grid households (Uchechi Obinna, Linda Wauben, Peter Joore, Angele Reinders). Presented at the 1st South East European Conference on sustainable development of Energy, Water and Environment systems (SEE SDEWES) Ohrid Macedonia (29 June- 3 July 2014).
7. A design-driven approach for developing new products for Smart Grid households (Uchechi Obinna, Linda Wauben, Peter Joore, Angele Reinders). Poster presented at the 5th IEEE PES Innovative Smart Grid Technologies Europe (ISGT Europe) conference, October 12-15 2014, Copenhagen Denmark.
8. Literature Study on Existing Smart Grids Experiences, Report, CESEPS project, 2017. Markočič, E., Hassewend, B., Obinna, U., Respinis, M. de, Reinders, A., Schram, W., Sark, W. van, Gultekin, E., Mierlo, B. van, Robledo, C., Wijk, A. van, Uebermasser, S. and Lehfuss, F.

Acknowledgements

Sometime in 2012, while I was still doing a research for the sustainable innovations programme of the Province of Fryslân, my father-in-law Hans van Meerendonk mentioned the possibility of doing a PhD related to the energy transition at the newly established University Campus Fryslân (UCF). Given my profound interest in research in general, and the topic of energy, I decided that I would give it a shot.

Some weeks later, I established contacts with Prof. Han Brezet and Peter Joore (Lector Open innovation, NHL), who were both involved in the UCF project. I was requested to forward my CV and a copy of my Master dissertation to the designated promotor, Prof. Angele Reinders.

Thereafter, we planned another meeting, where I would be told if the promotor considered me a possible candidate for the PhD. Fortunately, the promotor gave her approval for me to fill in the slot. This was how my PhD journey started in 2012.

The past 5 years of research in a new and multidisciplinary research area has proved to be rather interesting and challenging. I encountered many bumpy, uncertain and frustrating roads that left me pondering whether I would be able to make it to the finish line. Finally, it feels nice to see a flicker of light at the end of what sometimes appeared to be a dark tunnel.

I wouldn't have been able to graciously walk this long journey without the support and assistance of various people, who might be too numerous to mention.

I would like to express immense gratitude to Han Brezet (Prof .B), for setting the ball rolling. Without you, this journey wouldn't have been possible.

My sincere appreciation goes to my promotor, Prof. dr. Angele Reinders. Angele, thank you very much for accepting me to be your PhD student, and supporting me throughout the process. Although there were some rough times at different stages of my research, you stood by me and encouraged me all the way. I appreciate your guidance, supervision, stimulation, tough stance and never ending support throughout this journey. Thanks for all the opportunities you provided that contributed to the overall content of this thesis. I couldn't have reached the finish line without your support.

Dr.ir. Peter Joore, my daily supervisor and mentor, thanks for facilitating this journey all the way. I remain grateful to you for thinking along when I was lost, and helping to find solutions during tough times. I am very grateful for your support and encouragement, for involving me in various projects in your research group, making my stay at NHL stress-free, and ensuring that visits to conferences and project meetings were most pleasurable.

To Dr.ir. Linda Wauben, my supervisor, words alone cannot express how grateful I am for your involvement in my supervision. Linda, thanks a million for your intelligent inputs and helping to bring structure in my writing. Your constructive feedback on my papers,

thesis and research in general is highly appreciated. Without your help and critique, I may have been a lot more chaotic researcher than I turned out to be.

I wish to express my gratitude to the members of my thesis committee: Prof. dr. ir. J.C. Brezet, Prof. dr. A.R. Balkenende, Prof. dr. Jörg Henseler, and Prof. dr. ir. Renee Wever, for reviewing and approving my thesis.

To the entire UCF team Prof. Frans Zwart, Tonny, Githe, and the rest of the crew, thank you for your support and all the academic and social activities that you organized.

My sincere appreciation also goes to the people from PowerMatching City Smart Grid pilot project, Albert van den Noort, Frits blik and Ewoud Vos for giving me access to energy meter readings of households participating in the pilot.

Pecan Street organization, thanks for granting access to the dataportal and meter readings of households in your smart grid project.

Many thanks to the smart grid stakeholders who were interviewed in this research.

A special thanks also goes to the students who participated in the sources of innovation course at the University of Twente. This course served as a great input for this thesis.

Angele, thanks for involving me.

A special thanks goes to my former colleagues at the IDE department: Daphne, Charlotte, Georgia and the NHL: Asli, Abhigyan, Sarah, Tim, Floris for the nice times and conversations in the office, at conferences and other social gatherings.

Members of the NHL PhD network, thanks for all the great cooperation, inspiring workshops and amazing dinners. Marieke, thanks for supporting with excel whenever I came to you.

To the Sustainable Energy Design group of the University of Twente, thanks for the interesting discussions during our various meetings.

The secretaries of IDE: Csilla, Mariska, and Sara, I appreciate your friendly assistance at all times.

Rinske, thank you for the nice profile picture used in this book.

I also wish to recognize and thank my family for the outstanding support they gave me throughout this journey. A very special thanks to my parents for supporting me in realizing my academic dreams both at home and abroad. Many thanks to my mother for ensuring that I took my studies seriously, and making me read all those books and do my homework when all the kids in the neighborhood were playing football. To my father, the creative artist, thanks for your support and making the nice cover design of this thesis.

My lovely parents-in-law, I appreciate you for all that you have been doing for me. Thanks for being my family here and accepting me as your own. Papa Hans, this journey would not have been possible without you in the first place. Omi lmi and Hanneke, thanks for coming always to take care of the girls, and helping us with various household chores. It would have been tougher without your help, love and care.

My journey to the Netherlands had a beginning. A special thanks to my aunt Bertha for making it possible for me to pursue my dreams beyond the shores of Nigeria. To all my family in Amsterdam: Robin, Aunty Joy and kids, a very special thanks for supporting me in every way to settle down here in the Netherlands.

Adam, my great American friend, scientist and neighbor, thanks for being a big inspiration to me and your support with MATLAB.

And the last but not least, my lovely wife Hilde and my twin daughters. I thank God everyday for blessing me with all three of you, and little junior on the way. Hilde, you were a constant source of inspiration for me throughout this entire journey. Thank you for thinking along with me whenever I asked you to, and also checking and correcting my work. You always reminded me that I could do it. You were right, I did it.

Amara and Emema, my lovely daughters. I started this journey a few months after you were born. It became kind of normal for you to see me glued to the computer. To you, the MacBook was a first child to Papa because he paid more attention to that piece of equipment and its contents more than he did to you. I promise to make up for anytime lost during this during this PhD process.

Taking care of you and doing this PhD was tough, but I got a lot of inspiration to continue working hard by looking at you grow day by day.

As a Christian, I would end by thanking the good Lord for guiding and directing my path throughout this journey.

To all those important people I forgot to mention, it was not done on purpose.

Finally, my immense gratitude goes to the province of Fryslân and the NHL for providing the financial support and enabling environment to carry out this research.

Mei mooglijk make troch de Provinsje Fryslân.

