

## A Multi Frequency Deployable Antenna System for Delfi-PQ

Speretta, Stefano; Uludag, Sevket; Karunanithi, Visweswaran; Radu, Silvana; Chronas Foteinakis, Nikitas; Bouwmeester, Jasper; Menicucci, Alessandra; Gill, Eberhard

**Publication date**

2019

**Document Version**

Final published version

**Published in**

Proceedings of the International Symposium on Space Technology and Science, Fukui (Japan), June 15th-21st, 2019

**Citation (APA)**

Speretta, S., Uludag, S., Karunanithi, V., Radu, S., Chronas Foteinakis, N., Bouwmeester, J., Menicucci, A., & Gill, E. (2019). A Multi Frequency Deployable Antenna System for Delfi-PQ. In *Proceedings of the International Symposium on Space Technology and Science, Fukui (Japan), June 15th-21st, 2019* Article 2019-f-74

**Important note**

To cite this publication, please use the final published version (if applicable).  
Please check the document version above.

**Copyright**

Other than for strictly personal use, it is not permitted to download, forward or distribute the text or part of it, without the consent of the author(s) and/or copyright holder(s), unless the work is under an open content license such as Creative Commons.

**Takedown policy**

Please contact us and provide details if you believe this document breaches copyrights.  
We will remove access to the work immediately and investigate your claim.

# A Multi Frequency Deployable Antenna System for Delfi-PQ

By Stefano SPERETTA,<sup>1)</sup> Mehmet Sevket ULUDAG,<sup>1)</sup> Visweswaran KARUNANITHI,<sup>1)</sup> Silvana RADU,<sup>1)</sup> Nikitas CHRONAS-FOTEINAKIS,<sup>1)</sup> Jasper BOUWMEESTER,<sup>1)</sup> Alessandra MENICUCCI,<sup>1)</sup> and Eberhard GILL<sup>1)</sup>

<sup>1)</sup>*Delft University of Technology, Delft, The Netherlands*

This paper presents the design of a multi-frequency deployable antenna system for femto-satellites as part of the Delfi-PQ project, a PocketQube with a size of 50x50x178 mm which is being developed by the Delft University of Technology. This new form factor brings its own challenges on every subsystem and it is seen as a stepping stone towards even more miniaturised satellites. In this paper we present the design trade-offs, the analysis and the measurements on the antenna system. The system is designed to operate in 4 different bands to guarantee communications and payload operations. Due to the very limited available space on the external faces of the spacecraft, it was decided to deploy all the antennas and multiplex the different bands on the available antenna elements. VHF and UHF are used for satellite telemetry and commanding while a dual-frequency GPS receiver is intended as payload. The satellite design is presented, together with design drivers for such a system to justify the design choices. Three RF configurations are analysed and compared for omni-directional coverage and peak gain. RF measurements on one of the configurations is also presented to validate the simulations. The deployment system is also presented, giving details on the design and expected tests to complete the qualifications.

**Key Words:** PocketQube, Deployable Antenna System, GPS, UHF, VHF

## 1. Introduction

PocketQubes are a cube-shaped platform of 50x50x50 mm with a mass of no more than 250 g for which is also called as 1P.<sup>1)</sup> Delft University of Technology has been working on a 3P PocketQube with the dimensions of 50x50x178 mm. This new form factor brings challenges on every subsystem and it is seen as a stepping stone towards even more miniaturised satellites. Given the very small size of the spacecraft, payloads will be severely constrained, pushing a radical change in mission concept: from a very complex single instrument to many smaller ones.<sup>2)</sup> PocketQubes, thanks to their reduced size and mass, can be launched economically in large numbers to build a distributed swarm of sensors. Delfi-PQ<sup>3)4)</sup> aims at building a reliable core for a PocketQube and demonstrating critical technologies for future missions.<sup>5)</sup> PocketQubes have been gaining momentum in the last couple of years showing miniaturisation of different sub-systems (deployable solar panels,<sup>6)</sup> miniaturized spectrum monitoring instrument<sup>7)</sup> or space weather sensors<sup>8)</sup>), despite only four of them have been launched as of April 2019.

Delfi-PQ is being developed by the Delft University of Technology with an educational objective, bringing students directly in contact with space activities in a hands-on way.<sup>9)</sup> In view of these future developments, this paper aims at presenting a deployable antenna system for Delfi-PQ: due to the very small size of the spacecraft and the selected communication bands (VHF and UHF), a fixed antenna would not have the performances required for mission success. This antenna system is used for satellite T&C (Telemetry and Commanding) and also to operate the internal dual-frequency GPS receiver, operating on the L1 and L5 frequency bands. This GPS receiver is a commercial product intended for use on mobile applications and contains a modified firmware to operate in space. Using the same antenna set for GPS will complicate the design however, it will save volume in the satellite and it will relief some of the attitude requirements associated compared to the typical use of

patch antennae for GPS receivers. This paper presents the general Delfi-PQ system (Section 2.), giving details about the mission design and status. Design drivers for a deployable antenna system are presented in Section 3. to justify the reasons for design choices. The antenna system is then presented in details (Section 4.), including the antenna mechanical and RF (Radio Frequency) design and trading-off three different design solutions. Measurements are also presented to verify the correctness of the simulations performed. The deployment system is also presented (Section 5.) and conclusions are summarized in Section 6. together with suggestions for future work.

## 2. Delfi-PQ

Delfi-PQ (see also Fig. 1) is the first PocketQube developed by the Delft University of Technology, with the aim to set a mechanical standard for this type of satellite and flight test the structure as well as validating in flight the designed and developed core bus.<sup>3)</sup>

The long-term goal of Delfi-PQ is to develop a core platform with basic functionalities that will be developed in an iterative approach over time. Since this effort is being carried out by a university, it is desired that as many students as possible work on the developed satellite. All previous missions carried out had a clear objective for education, technology demonstration and innovation. It is intended that once the first design of the satellite is validated in flight, there will always be a satellite available ready for an eventual launch.

The first mission objective is education and, in particular, giving students a practical experience with a space project as part of their education. This is one of the reasons for the iterative design approach: by performing small design updates and going through the full testing and qualification cycle each time, we expect to give a realistic experience to students being involved in the different design phases. A second objective for Delfi-PQ is technology demonstration, intended to provide a flight



Figure1. Delfi-PQ.

opportunity to different technologies developed by university researchers, such as:

- A dual thruster system based on VLM (Vaporizing Liquid Micro-resistojet) and LPM (Low Pressure Micro-resistojet).<sup>10</sup> This payload is part of a long-term development effort and key technologies will be demonstrated but it will not be used for orbit control of the spacecraft;
- A commercial GPS payload with a modified software;
- A thermal payload made by one partner that aims at demonstrating innovative thermal components. This payload will potentially be integrated if the timelines of readiness of payload and planned integration are compatible;
- Optical reflector aimed at increasing the selectivity of the spacecraft. Also used to compare the tracking performances of NORAD and other providers;<sup>12</sup>

The spacecraft has a form factor of 50x50x178 mm and internally is made by a single stack of boards (see Fig. 2 for further details) stacked on top of each other. All boards rely on a connector providing electrical connectivity and on 4 rods providing mechanical support. The satellite is made by five main sub-systems: power (Section 2.1.), communication (Section 2.2.), the on-board computer (Section 2.3.), attitude control (Section 2.4.) and the antenna (Section 4. and 5.).

The second objective of the mission is developing a reliable satellite core bus such that it can be re-used and extended in future missions. This is also the reason why a lot of efforts have been spent on devising an internal standard (and also the overall PocketQube standard<sup>1</sup>).

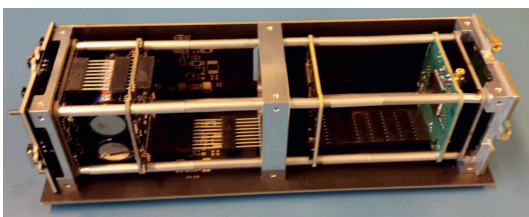

Figure2. Delfi-PQ internal view.

## 2.1. Power system

The power system main function is to provide power to the subsystems and payloads. Delfi-PQ uses triple junction GaAs solar cells with approximately 30% efficiency. The satellite has four body mounted solar panels as energy source while storage is guaranteed by two Li-Ion cells. The power system is shown in Fig. 3, showing also on four sides the spring-loaded connection to the solar panels. This solution has been selected as the internal space is very limited and accommodating wires would have been a serious issue during the AIV (Assembly, Integration and Verification) phase. In this way, instead, integration is very simple and, given the reduced dimensions of all the components (which makes the structure relatively stiff compared to bigger spacecrafts), vibrations do not pose a serious risk to the system. The lowest eigenfrequency for the complete satellite is higher than 300 Hz,<sup>11</sup> making the satellite ready to be launched on all major available rockets.

## 2.2. Communication system

The communication system is based on a commercial IC (Integrated Circuit) for IoT (Internet of Things) applications (SX1278 from Semtech<sup>9</sup>) which allows to build a full-duplex radio in an extremely compact volume (see Fig. 4 for further details). The system allows also full control over the radio, allowing to support multiple protocols with a little effort. AX.25 support has been implemented to allow radio amateurs to receive the telemetry and a custom protocol has also been implemented to experiment with advanced forward error correction schemes. The radio has been designed keeping in mind flexible operations to accommodate both a beacon for reception by amateur stations around the world and a commanded high speed downlink to be used over Delft (The Netherlands), where the control ground station is located. A high-power high-efficiency power amplifier has also been designed, allowing a maximum 1 W output power with an efficiency greater than 64%. A low power mode (250 mW) has been also implemented with an efficiency also greater than 60%.

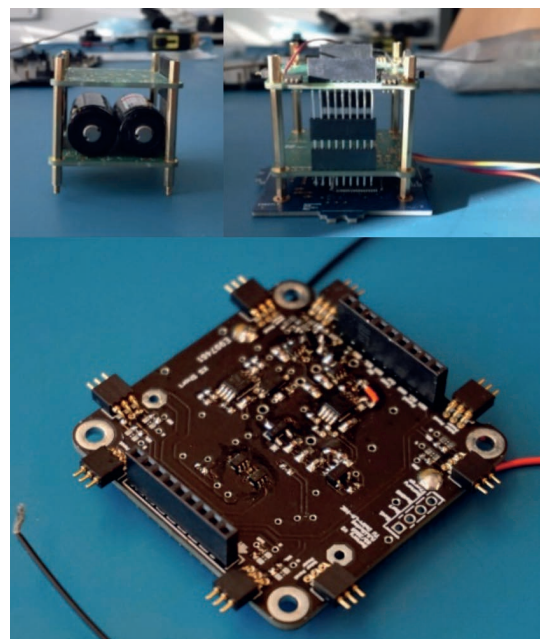

Figure3. Delfi-PQ power system.

### 2.3. On-board computer

The On-Board Computer (OBC) is based on the Texas Instruments MSP432 micro-controller, allowing up to 2 MB of FLASH memory and 256 kBytes of RAM and a maximum speed of 48 MHz. All this with a power consumption of only 65 mW: such a low power consumption is fundamental for a system like the OBC that requires to be on the whole time to control the satellite and for a spacecraft whose orbit average available power is only 1 W. The OBC is responsible for planning the on-board activities, handling ground commands and perform data collection, storage and transmission to the ground station.

### 2.4. Attitude control

The attitude control board is responsible for controlling the orientation of the satellite and it relies on magnetic field sensing and control, given the very small volume and power available. At the current stage, only detumbling has been foreseen for the system to ensure the satellite can safely communicate with the ground station and the deployment-induced rotations are limited. This is achieved with a simple 3-axis magnetic actuator. The coils have been manufactured using a 3D-printed support and optimizing the power consumption to ensure the satellite can be slowed down from a worst case tumbling rate in less than 1 day with a power consumption of less than 300 mW.

## 3. Design drivers

Several high-level requirements have been considered before starting the design of the antenna system and, in particular, several families of constraints have been identified and are described in the following sub-sections.

### 3.1. Mechanical constraints

From the mechanical point of view, the main choice was the type of antenna elements to use. Similar deployable antennas are based on flexible metal stripes (shape memory alloys or measuring tape alike solutions) but they all require a container to hold the folded antenna. The minimum bending radius of these folded antennas is limiting the miniaturization potential and such a system would cost a relatively high fraction of internal volume. Therefore, solutions which utilize mainly external volume (as described in the PocketQube standard<sup>1)</sup>) have a preference. Holding the folded tape on the external panels would have required protecting the solar cells against the rattling during launch, making the solution more complex and bigger. In our case, rigid rods were selected as they do not occupy space internally but they are stowed outside the satellite. The rigid



Figure4. Delfi-PQ communication system.



Figure5. On-board computer.

rods also have limited rattling during vibrations due to their stiffness, actually not requiring a holding mechanism. This solution works well given the dimensions of the spacecraft but would not apply to smaller ones due to the low frequency of operations. The hold-down mechanism for the antenna elements is also a critical item: very limited space is available on the solar panels so the mechanism has been located on the satellite top panel. This forced the antenna element length to be fixed (to fit in the deployer and to allow the element to be held down). RF matching could then only be performed electrically and not by adapting the antenna length.

### 3.2. RF propagation constraints

An omni-directional radiation pattern is fundamental to guarantee the satellite can be commanded in any attitude, also in case of failure of the attitude control system. This was the main driver in looking at monopole and dipole antennas, together with the need to operate in VHF and UHF (to re-use the existing ground station). Low antenna gain is a consequence of such choice and it has been dealt with by increasing the transmit power on the satellite side and on the ground. It should be noted that the ground station currently uses circularly-polarised antennas (selectable between left- and right-hand circularly polarised). Using circular polarisation on board the spacecraft would have provided minimal polarisation losses in the case of a stabilised satellite. But, considering a fault in the attitude control system possible, it might have caused the satellite to spin and change polarisation as a function of the attitude. This is solvable by switching the ground polarisation but it would have made operations less convenient. It was thus decided to take an additional 3 dB polarisation mismatch loss and use linear polarisation on the space side.

### 3.3. RF constraints

The most important driver was the band selection: VHF was selected for the uplink receiver and UHF for the downlink transmitter based on the available ground station hardware. The GPS frequencies were dictated also by the available hardware. The



Figure6. Attitude control system.



antenna radiation pattern was the second design driver: due to the potential lack of attitude control (in case of failure of the system in flight), an omni-directional coverage for all bands was fundamental. In case of a spinning satellite and a directional antenna, the GPS receiver might have an intermittent signal lock, causing the failure of the experiment and the same would apply for the uplink receiver. Transmit power was the next important parameter: in order to guarantee a good data downlink rate, it was decided to aim for 9600 bps and eventually higher. From the link analysis, it was clear that at least 0.5 W of RF power was required and the final power amplifier design lead to a flexible power level, ranging from 0.25 W to 1 W, with an efficiency always higher than 60%. From the operational point of view, it was also decided to strive for full-duplex operations, allowing the receiver to achieve its full sensitivity also when the transmitter is active. This lead us to also optimize the antenna design for a high isolation between the VHF and UHF band. The GPS bands can be accommodated easily as the wide frequency separation allows for low insertion loss filters to be also used.

#### 4. Antenna system

The antenna system is made by a set of monopole antennas, attached to the satellite body using a rotating elbow and a spring for ensuring the deployment: more details can be seen in Fig. 7 where the RF (Radio Frequency) measurements model is depicted. Conceptually the system is quite simple but it needs to reliably operate as the success of the mission is tied to it.

From the mechanical point of view, a deployable antenna was selected to aim as much as possible to an omni-directional radiation pattern, as the system is expected to be used for T&C. The omni-directional coverage will allow to command and receive the satellite in the widest range of attitudes, especially because the attitude control system will be tested for the first time in this mission as well. Due to the satellite shape, as seen in Fig. 1 with the antennas in stowed condition, the antennas are attached to the top and bottom panel of the spacecraft, actually constraining the length of the elements to approximately 180 mm. This configuration was selected as it is close to the optimal length for a transmitter operating in UHF that would allow to reuse the existing ground station. But, as stated before, this is close to the required length (172 mm) but not exactly, leading to an antenna with non-optimal impedance matching. This will be achieved using a matching network to ensure optimal RF and mechanical characteristics. Beside the UHF on-board transmitter, this antenna system is envisaged to operate also in VHF (connected to the on-board command receiver, selected also to re-use the existing ground segment). Furthermore, it was also selected to use it for receiving the GPS signals for one of the experimental payloads. This solution makes the antenna system operating in 4 different bands, actually making the design quite complex. As it can also be seen from Fig. 7, it can fit as one of the side panels of the spacecraft and it can accommodate up to four single monopole antennas that could then be combined to create a more performing antenna. This section will analyse three different configurations to show the best solution to fit all the design requirements, as they were as listed in Section 3.

#### 4.1. Mechanical design

The mechanical design for the antenna elements is based on a very simple concept (a 90° rotating elbow, a hold-down mechanism and a rigid stick) but it was made much more complex by its size. The rotating elbow is made using a commercial MMCX connector to both provide mechanical and electrical connection. The connector was not originally designed to host a rotating contact but, given the limited number of rotations the system needs to perform (in-flight deployment plus few tests on ground), this did not appear to be a risk. RF (Radio Frequency) performances have been measured before and after 100 rotations with no noticeable degradation, proving the concept is valid. The biggest risk that has been identified is the possibility for the connector to unplug due to side vibrations or shocks, leading to the loss of the antenna element. The connector has a retention force of 45 N which, combined with a mass for the complete element (spring, connector and metal rod) of less than 45 g, would require an acceleration of 100 G to unplug the element. This clearly poses no risk under random vibrations as such an acceleration would be much higher than the qualification loads considered (14.1  $G_{rms}$ , based on NASA GEVS<sup>13</sup>). Shock loads instead could range up to 1000  $G^{14}$  or 10000  $G^{15}$  and would be enough to cause an eventual disconnection of the element. To avoid such a problem, a restraining metal structure has been placed in front of the connector (black element, visible in Fig. 7): the element allows the connector to rotate freely (also at maximum and minimum storage temperature) but limits the maximum extraction to the pull-in range of the retention spring. This way, upon partial disconnection, the retention spring is able to pull back the connector in and guarantee safe operations. Upon antenna deployment, two springs are used to guarantee the complete deployment of the antenna elements that are pushed against an end stop. Since the stop and the springs are metallic parts, they might short the antenna element to the structure and prevent proper operations: to avoid this, isolation has been added (using a polyimide film) whose performances has been accounted for from the RF (Radio Frequency) point of view. The antenna element is made by a gold-plated brass tube, which has been selected for its rigidity in the stowed phase, allowing a simple clamping mechanism at the end of the tube with no stiffener in the center. All the area below each antenna element is used to host solar cells, which have been spaced by a

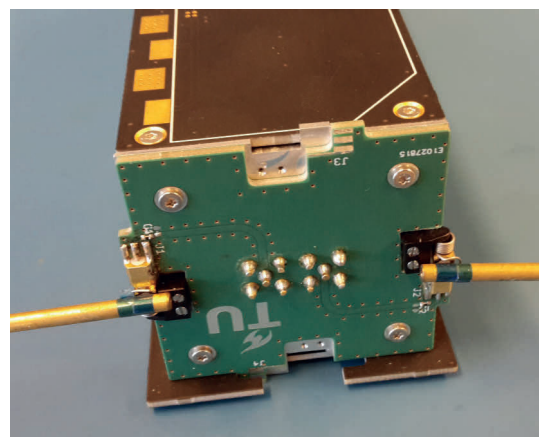

Figure7. Antenna system RF measurements model (dipole configuration).

gap to ensure the bending of the rigid element under vibrations cannot damage them.

#### 4.2. RF design trade-off

Based on the system requirements (highlighted in Section 3.), the antenna system has to operate in four separate bands: VHF (144 - 146 MHz), UHF (430 - 440 MHz), GPS L1 (1575 MHz) and GPS L5 (1200 MHz), while the antenna element physical size is constrained to approximately 180 mm (for mechanical reasons). Electronic matching in multiple bands is thus required, making the design significantly more complex. Thanks to the flexibility of the antenna system, capable of hosting up to four single elements and combining them in an arbitrary way, a trade-off analysis has been made to identify the most convenient solution given the requirements. The main criteria used to evaluate the different solutions have been:

- **omni-directional design:** the presence of a narrow lobe in the antenna radiation pattern can limit the possible attitudes allowing safe communication with ground and so endangering the mission;
- **maximum gain** helps reducing the required power on-board on the transmitter and maximizes the sensitivity of the antenna;
- **isolation between bands** is required to allow operations of the receivers (T&C and GPS) also when the transmitter is operational.

Three main solutions have been identified, which cover parts of the full design space, but limit the complexity of the system. These solutions are presented in the next sub-sections and a final selection is presented in Section 4.2.4..

##### 4.2.1. Dipole antenna

A dipole antenna is made by two monopole antennas connected in phase opposition: this solution has generally omni-directional pattern with two narrow and deep nulls coincident with the monopoles axis. Peak gain (theoretically) is 2.16 dB, which can be considered relatively high for an omni-directional coverage. It should be noted, though, that these are purely theoretical considerations and the effective radiation pattern will be heavily influenced by the satellite structure, which is of a similar size with respect to the antenna elements). A single antenna will require to be RF-matched to ensure optimal power transfer and guarantee adequate isolation between all the operational bands. Coupling between the different ports (driven by the non perfect isolation between them) is particularly critical with respect to the UHF port, which can be as strong as 30 dBm when the downlink transmitter is on. Handling such power level in a small volume proved also complex due to the lack of components with such a power rating (only a very small number was found, limiting the possible design options). The performances of this solution are summarised in Table 1. Peak gain in the table already includes the insertion loss of the matching networks to give an overall figure of merit for the implementation. Isolation is calculated always with respect to the UHF channel as it is the only transmitter that could degrade the receiver performances when in operations. The beamwidth has been calculated with respect to a gain of 0 dBi for consistency with all the antennas and because all antennas are designed for an omni-directional radiation pattern. The radiation pattern for all the antennas is shown in Fig. 8. The satellite link budget

Table1. Dipole performances.

Band	Max Gain (dBi)	Isolation (dB)	0 dB Beamwidth (deg)
VHF	2.7	31	200
UHF	2.5	-	160
GPS L1	2.6	37	115
GPS L5	6.6	39	220

has also been calculated using a 0 dB antenna gain to be consistent with such an approach. It should be furthermore noted that the radiation patterns are heavily influenced by the structure of the satellite, not showing a clear main lobe with side lobes but rather a set of main lobes. Describing the antenna in terms of -3 dB beamwidth could have thus crated confusion on the actual antenna pattern.

##### 4.2.2. Double monopole antenna

To address the complexity of the matching network, a first modification was attempted by splitting the dipole antenna into two separate monopoles: one of the two will be used for the GPS (L1 and L5 frequency) and the command receiver (VHF) while the second monopole will be used for the T&C downlink (UHF). This solution reduces drastically the complexity of the matching network (and so its losses that directly impact the antenna gain) but it introduces coupling between the elements. All the radiation patterns are shown in Fig. 9. The transmitting element does not require any complex matching network and it can be directly connected to the antenna element, achieving a 0.5 dB insertion loss. This solution is advantageous because it takes away the need for a high power matching network for VHF and GPS, providing more design freedom. The overall performances are shown in Table 2.

In order to verify the correctness of the simulations, this antenna configuration has been measured and compared against the simulated value. Measurements were done on the RF reflection coefficient, as it is a good indication of eventual problems. The results are summarised in Table 3, which shows that

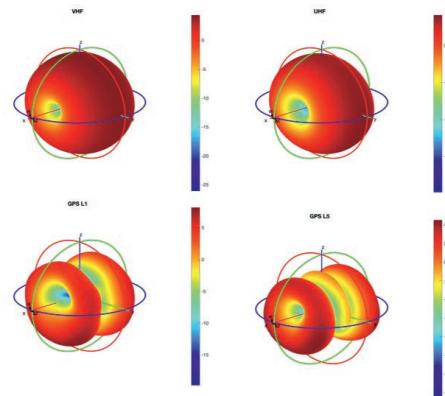

Figure8. Dipole antenna radiation patterns.

Table2. Double Monopole performances.

Band	Max Gain (dBi)	Isolation (dB)	0 dB Beamwidth (deg)
VHF	2.1	19	120
UHF	3.0	-	130
GPS L1	7.8	19	125
GPS L5	6.2	19	130

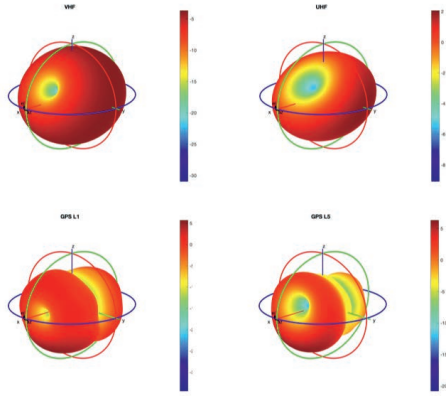

Figure9. Monopole antennas radiation patterns.

measurements and simulation are in good agreement. The radiation pattern has not been measured yet but the measurement is planned before the launch of the spacecraft.

#### 4.2.3. Dipole and monopole antenna

The weak point of the double monopole solution is the limited isolation between the elements, as they are extremely close and co-linearly polarised. This translates into additional filters being needed on the receiver sides, which will further degrade the performances. The peak antenna gain in the previous two solutions is very similar, not constituting a valid criterion to select. An alternative solution to improve the isolation is to use an additional antenna (monopole) for the transmitter and locate it perpendicular to the dipole, to increase the isolation thanks to the polarisation mismatch (see Fig. 10 for further details). This solution inherits most of the advantages of the dual monopole solution, actually having a simple matching for the UHF monopole and not requiring high power rating components. As shown in Table 4, performances are similar but with an improved isolation. The radiation patterns are also shown in Fig. 11. The UHF monopole shows also no significant null in the radiation pattern, making it also a safer option in case the satellite attitude control is lost. The dipole shows performances very similar to the first case analysed but with a slightly lower isolation, anyway much better than the second option.

#### 4.2.4. Final solution

Three solutions have been shown in this paper as they were the solutions that have been fully simulated and some of them also measured. Not all possible solutions have been considered (such as, for example, 4 independent monopole antennas) but they are being still evaluated. Due to the short development time for the complete satellite, other solution will be considered as a future improvement, deemed to fly on follow-up missions. Putting together the simulations from the previous sections, we concluded that the last solution (a monopole and a dipole antenna) shows the best performances, based on the design drivers presented in Section 3. and 4.2.. This last solution

Table3. Double Monopole reflection coefficient.

Band	Measurement (dB)		Simulation (dB)
	Dipole 1	Dipole 2	Simulation
VHF	-0.1	-0.1	-0.06
UHF	-6.0	-6.6	-9.2
GPS L1	-9.1	-10.5	13.6
GPS L5	-2.4	-3.9	-3.1

Table4. Antenna system with a monopole and a dipole.

Band	Max Gain (dBi)	Isolation (dB)	0 dB Beamwidth (deg)
VHF	2.7	34	200
UHF	2.0	-	190
GPS L1	2.5	34	115
GPS L5	6.4	34	225

presents three deployable elements but it is not considered to increase the complexity of the system very much. With respect to the single dipole solution, the multi-frequency matching network is simpler and it does not require to handle the full transmitter power but a maximum power of less than 0 dBm. The deployment system (see Section 5. for further details) can accommodate up to 4 separate elements, so this solution does not add in complexity.

## 5. Deployment system

The deployment system is based on a burn-wire, holding each single element, and a thermal knife used to cut it. The wire is a standard Dyneema wire tied around the antenna element and around a resistor used as a thermal knife: once the resistor body temperature rises above 140 °C, the wire melts and the element is released. This procedure is autonomously handled by a micro-controller on the board, which also uses a deployment switch to turn-off the thermal knife after deployment. The deployment system is shown in Fig. 12. As the antenna deployment is mission critical, a strong fault-analysis has been done on the system to have an autonomous solution of the eventual problems. A low state-of-charge of the battery might mean that the power system could interrupt the deployment procedure and restarting the procedure will happen autonomously once a sufficient state-of-charge is achieved again. A fault to the deployment switch might also compromise antenna deployment (leading to a continuous usage of the thermal knife or wrong signal confirming antenna deployment). An automatic strategy has been implemented partially in the deployment system, targeting low-level faults, while a more complex strategy has also been implemented in the on-board computer. In particular, a timeout on ground commands can also trigger an extra deployment (conditioned by the battery status-of-charge and the actual temperature) to ensure the satellite can be ready for operations also in case of faults.

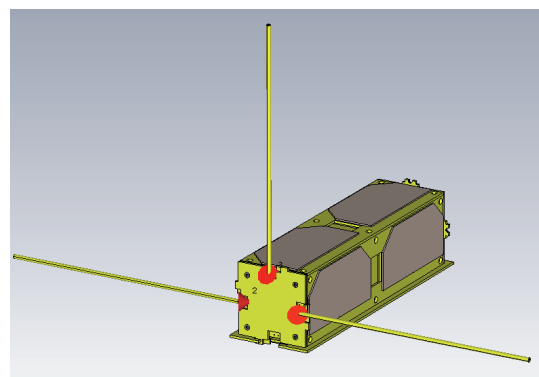

Figure10. Antenna system with a monopole and a dipole.

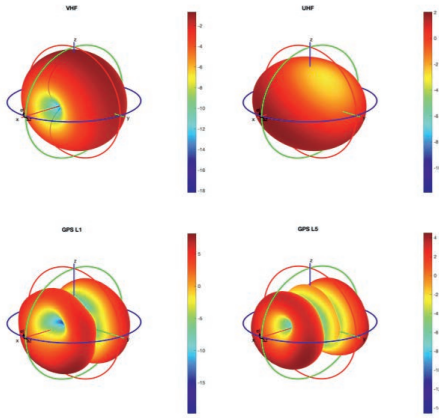

Figure 11. Dipole and monopole antennas radiation patterns.

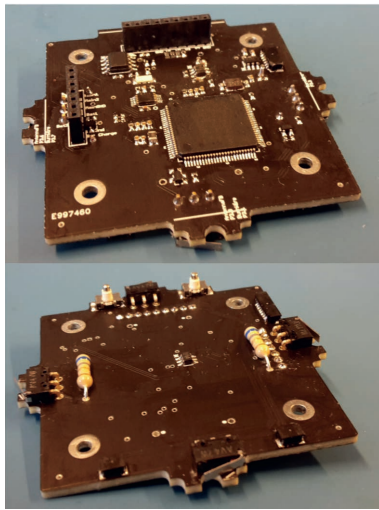

Figure 12. Deployment board.

## 6. Conclusion

In this paper we presented a multi-frequency antenna system suited for a PocketQube. The system was design as part of the Delfi-PQ project, aiming at developing, as part of the educational curriculum in Aerospace Engineering at the Delft University of Technology. A trade-off is presented based on simulations between three possible antenna configurations, selected based on the best omni-directional profile, the best maximum antenna gain and the best isolation between the different bands in which the antenna is operating. Measurements are also presented to show that they are in good agreement with the simulations. The best solution identified is able to multiplex the four bands of interest (VHF, UHF, GPA L1 and L5) on two separate antennas, a dipole (used for VHF, GPS L1 and L5) and a monopole (used for UHF), providing a good isolation between

the transmitter port (UHF) and the other ports, actually allowing operations during transmission.

## References

- 1) Radu, S., Uludag, M. S., Speretta, S., Bouwmeester, J., Menicucci, A., Cervone, A., Dunn, A., Walkinshaw, T., Kaled Da Cas, P. L., Cappelletti, C., and Graziani, F.: PocketQube Mechanical Interface Standard, <https://dataverse.nl/api/access/datafile/11680>, (accessed April 5, 2019).
- 2) Jones, N.: Mini satellites prove their scientific power, *Nature.*, **508** (2014), pp. 300–301.
- 3) Radu, S., Uludag M. S., Speretta, S., Bouwmeester, J., Gill, E. and Foteinakis, N.: Delfi-PQ: the first PocketQube of Delft University of Technology, 69th International Astronautical Congress, Bremen, Germany, IAC 2018.
- 4) Bouwmeester, J., Gill, E., Speretta, S. and Uludag, S.: A New Approach on the Physical Architecture of CubeSats & PocketQubes, *JBIS.*, **71** (2018), pp. 239–249.
- 5) Bouwmeester, J., Radu, S., Uludag S., Chronas Foteinakis, N., Speretta, S., Menicucci, A. and Gill, E.: Conditions and Potential Applications for PocketQubes, Small Satellites, System & Services Symposium, Sorrento, Italy, 4S 2018.
- 6) Li, D., Harkness P. and Walkinshaw, T.: Design of a solar panel deployment and tracking system for Pocketqube pico-satellite, IEEE Aerospace Conference, Big Sky, Montana (US), Aeroconf 2017.
- 7) Dudas, L., Gschwindt, A.: The communication and spectrum monitoring system of Smog-1 PocketQube class satellite, 21st International Conference on Microwave, Radar and Wireless Communications, Krakow, Poland, MIKON 2016.
- 8) Cachia, D., Camilleri, J., Azzopardi, M.A., Angling, M., Sammut, A.: Feasibility Study of a PocketQube Platform to Host an Ionospheric Impedance Probe, Small Satellites, System & Services Symposium, Valletta, Malta, 4S 2016.
- 9) Speretta, S., Prez Soriano, T., Bouwmeester, J., Carvajal Godnez, J., Menicucci, A., Watts, T., Sundaramoorthy, P., Guo, J. and Gill, E.: CubeSats to PocketQubes: Opportunities and challenges, 67th International Astronautical Congress, Adelaide, Australia, IAC 2016.
- 10) Pallichadath, V., Turmaine, L., Silva, M. A. C., Cordeiro Guerrieri, D., Uludag, S., Zandbergen, B. and Cervone, A.: In-orbit micro-propulsion demonstrator for pico-satellite applications, 69th International Astronautical Congress, Bremen, Germany, IAC 2018.
- 11) Uludag M. S., YAKUT, E., Speretta, S., Radu, S., Chronas Foteinakis, N., Bouwmeester, J., Menicucci, A. and Gill, E.: Getting the Delfi-PQ Ready for Multiple Launch Options, International Symposium on Space Technology and Science, Fukui City, Japan, ISTS 2019.
- 12) Speretta, S., Sundaramoorthy, P. and Gill, E.: Long-term performance analysis of NORAD Two-Line Elements for CubeSats and PocketQubes, Proceedings Small Satellites for Earth Observation, Berlin, Germany, 2017.
- 13) General Environmental Verification Standard, NASA, 2019, <https://standards.nasa.gov/standard/gsfsc/gsfsc-std-7000>, (accessed April 10th, 2019).
- 14) Electron User Guide, 2018, <https://www.rocketlabusa.com/assets/Uploads/Rocket-Lab-Payload-Users-Guide-6.2.pdf>, RocketLab, 2018, (accessed April 10th, 2019).
- 15) VEGA User Guide, Ariane Space, 2014, [http://www.arianespace.com/wp-content/uploads/2015/09/Vega-Users-Manual\\_Issue-04\\_April-2014.pdf](http://www.arianespace.com/wp-content/uploads/2015/09/Vega-Users-Manual_Issue-04_April-2014.pdf), (accessed April 10th, 2019).