

MASTER THESIS

Feasibility of Circular Bio-based Unitised Façade Systems

by

Katia Flores Mejía

Delft University of Technology



Feasibility of Circular Bio-Based Unitised Façade Systems

by

Katia Flores Mejía

to obtain the degree of Master of Science in Civil Engineering

at Delft University of Technology,

to be defended publicly on October 12th, 2023

Student number: 5596149

THESIS COMMITTEE:

prof. dr. ir. Christian Louter
dr. ir. Roel Schipper
drs. Wolfgang Gard
dr. Andrea Zani

Applied Mechanics
Applied Mechanics
Biobased Materials and Structures
Permasteelisa Group



Acknowledgements

I would like to express my gratitude to my thesis committee members without whom this project would not have been possible. This project has been a great learning experience, and I'm thankful for their generosity in sharing their expertise and knowledge in the field.

My deep appreciation goes to my family and Yuri, who have always supported me and encouraged me to complete my educational goals, and to always choose a path that I am passionate about and believe in regardless of the challenges.

This master's program has introduced me to new friends and colleagues that share the same passion about the field, and I couldn't be more grateful for their support and encouragement.

Abstract

This thesis project proposes the introduction of bio-based materials in the design of unitised curtain wall façade systems. The work investigates a circular bio-based unitised façade design to understand its feasibility regarding thermal, technical, and environmental performance. The research is divided in four phases, including the material, system design, performance, and environmental assessment level.

The material phase serves as a literature review to study the current technologies and available bioproducts in the market to make an informed selection. Once the materials are selected, the system design phase starts with an emphasis on dynamic construction and design for disassembly features.

Overall, this study aims to minimize reliance on non-renewable resources such as aluminium in façade systems. Therefore, it is important to analyse the thermal and hygrothermal behaviour of the materials to integrate design characteristics that can improve their performance while protecting their structural integrity.

After the feasibility of the design concepts gets validated, a comparative environmental assessment against standard aluminium façade systems is conducted to quantify the sustainability impact of the proposed system. Ultimately, the research project proposes a detailed exploration into the feasibility of circular, bio-based unitised façade systems. Therefore, the introduction of bio-based systems that support sustainable methodologies and practices from the material, design, and system level is demonstrated.

Table of Contents

1. INTRODUCTION	6
2. RESEARCH FORMULATION	8
2.1. STATE OF THE ART	8
2.2. THESIS TOPIC	11
3. METHODOLOGY OVERVIEW	13
3.1. DESIGN PROPOSAL	13
3.2. RESEARCH STRUCTURE	16
3.3. RESEARCH QUESTIONS.....	18
3.4. RESEARCH OBJECTIVES.....	19
4. MATERIAL STUDY: BIO-BASED MATERIALS	21
4.1. TIMBER FRAMING MATERIAL SELECTION	21
4.2. SPANDREL MATERIAL SELECTION	29
5. UNITISED CURTAIN WALL SYSTEM DESIGN	33
5.1. STANDARD ALUMINIUM CURTAIN WALL SYSTEM	33
5.1.1. Stick System:	34
5.1.2. Unitised System:.....	35
5.2. CURRENT BIO-BASED FAÇADE SYSTEMS	36
5.3. RELEVANCE OF TIMBER IN FAÇADE DESIGN	38
5.4. HYBRID CURTAIN WALL SYSTEMS.....	40
5.5. PHASE I - PRELIMINARY FAÇADE DESIGN CONCEPT FORMULATION	41
5.5.1. Design Strategy.....	41
5.5.2. Glazing System.....	43
5.5.3. Connection Systems.....	44
5.5.4. Material Implementation Stainless – Steel	46
5.5.5. Preliminary Design Cross-Sections	47
5.5.6. Moisture Control.....	50
5.6. PHASE II - DESIGN FOR DISASSEMBLY.....	51
5.6.1. Functional Decomposition.....	52
5.6.2. Technical Decomposition	54
5.6.3. Physical Decomposition	54
6. PERFORMANCE ASSESSMENT & SYSTEM OPTIMIZATION	56
6.1. INTRODUCTION.....	56
6.2. STEADY- STATE THERMAL ANALYSIS.....	56
6.2.1. Therm 7.8 Simulation Set-up.....	56
6.2.2. Thermal Transmittance (U-Value) Calculation.....	57
6.2.3. Preliminary Condensation Risk Assessment	62
6.2.4. Results & Recommendations.....	65
6.3. HYGROTHERMAL ANALYSIS	66
6.3.1. Wufi 2D Motion Set Up.....	66
6.3.2. Methodology Overview	66
6.3.3. Initial Conditions	67
6.3.4. Climatic Conditions.....	67
6.3.5. Boundary Conditions	68

6.3.6.	Schematic & Proposed Materials.....	69
6.3.7.	Sources.....	69
6.3.8.	Air Gap Configuration.....	70
6.3.9.	Computational Parameters.....	70
6.3.10.	Critical locations to be analysed.....	70
6.4.	IMPACT OF STAINLESS-STEEL SHEET ON TIMBER FRAMING.....	71
6.4.1.	Relative Humidity.....	71
6.4.2.	Moisture Content.....	73
6.4.3.	Dimensional Stability.....	74
6.4.4.	Condensation Risk Assessment.....	79
6.4.5.	Mould Growth.....	82
6.4.6.	Recommendations.....	84
6.5.	ANALYSIS OF SPANDREL MATERIALS.....	86
6.5.1.	Methodology.....	86
6.5.2.	Schematic.....	86
6.5.3.	Impact of Insulation & Weather Resistive Barriers.....	88
6.5.4.	Mould Growth Assessment.....	91
6.6.	RECOMMENDATIONS.....	92
6.7.	CONCLUSIONS.....	92
7.	FINAL DESIGN.....	96
8.	LIFE CYCLE ASSESSMENT.....	99
8.1.	LCA – CALCULATION METHOD.....	99
8.2.	BIO-BASED MATERIAL CONSIDERATIONS.....	101
8.3.	SCOPE OF THE ANALYSIS.....	101
8.4.	FUNCTIONAL UNIT.....	102
8.5.	SYSTEM PRODUCTION DESCRIPTION & CONSTRUCTION PROCESS.....	103
8.6.	MATERIALS QUANTITIES.....	108
8.7.	RESULTS.....	109
8.8.	CONCLUSIONS.....	115
9.	SUMMARY & DISCUSSIONS.....	118
9.1.	PRIMARY FINDINGS.....	118
9.2.	SECONDARY FINDINGS.....	120
10.	CONCLUSIONS & RECOMMENDATIONS.....	122
10.1.	RESEARCH QUESTIONS.....	122
10.2.	LIMITATIONS & AREAS OF FURTHER ANALYSIS.....	123
11.	REFERENCES.....	126

List of Figures

3.1: First conceptual design of circular bio-based unitised façade system.....	15
3.2: Methodology Layout, Source: by author.....	17
4.1: Bending Strength [N/mm ²] comparison among wood products.....	26
5.3: External Cladding Kit (ECK) created by BioBuild. Source: BioBuild.....	36
5.4: External Wall Panel created by BioBuild. Source: BioBuild.....	37
5.7: RAICO Element + H-I – Hybrid Unitised Façade System, Source: RAICO.....	40
5.8: Preliminary design concept layout. Source: by.....	42
5.9: Triple glazing system used in proposed bio-based façade system, Source: by author.....	44
5.10: Toggle clamping mechanism shown in a stick-built curtain wall system. Source: Sage Glass.....	45
5.11: Discrete Toggle Configuration for Preliminary Bio-based Design Concept. Source: by author.....	45
5.12: Slotted stainless-steel plate (left) & stainless-steel countersunk connection. Source: IstructE/TRADA,2007.....	46
5.13: Preliminary Design Concept: Vision Mullion Cross-Section. Source: by author.....	48
5.15: Preliminary Design Concept: Intermediary Transom Cross-Section. Source: by author.....	49
5.16: Preliminary Design Concept: Consecutive Transom Cross-Section. Source: by author.....	49
5.17: Moisture control strategies for preliminary design cross-sections with stainless steel covering sheet - Configuration A (left) & without the protective sheet – Configuration B (right). Source: by author.....	50
5.18: Relation between disassembly aspects and design domains. Source: Durmisevic 2006.....	52
5.19: Functional Independence Diagram for Preliminary Design Concept. Source: by author.....	53
6.1: Schematic for the material properties of Configuration A (left) & Configuration B (right) for the proposed bio-based façade system mullion. Source: by author.....	60
6.2: Material properties & mullion schematic for the aluminium curtain wall unit. Source: Scheldebouw B.V 61	
6.3: Condensation Assessment for Consecutive Stack Cross-Section for Configuration A – stainless steel and Configuration B.....	63
6.4: Condensation Assessment for Intermediary Transom Cross-Section for Configuration A – stainless steel and Configuration B.....	64
6.5: Condensation Assessment for Vision Mullion Cross-Section for Configuration A – stainless steel and Configuration B.....	64
6.6: Condensation Assessment for Consecutive Stack Cross-Section for Configuration A – stainless steel and Configuration B.....	65
6.7: Outdoor weather conditions for the city of Brussels. Source: Wufi Software.....	68
6.8: Indoor weather conditions which the proposed bio-based façade system is subjected to. Source Wufi Software.....	68
6.9: Schematic Representation of the analysis zone location of the wall assembly. Source: by author.....	71
6.10: Vision Mullion Schematic for Configuration A (left) and Configuration B (right) modelled in Wufi 2D.....	72
6.11: Relative Humidity Fluctuation over the 3 years for both façade system configurations cross-sections.....	73
6.12: Moisture Content Fluctuation over the 3-year period for both façade system configurations cross-sections.....	74
6.13: Initial Dimensions of timber mullion and transoms based on its grain orientation.....	75
6.14: Tangential & Radial Shrinkage and swelling [%] comparison in the vision and spandrel mullion for both configurations.....	76
6.15: Tangential & Radial Shrinkage and swelling [%] comparison in the Intermediary and Consecutive Stack Transom for both configurations.....	76
6.16: Moisture Content [%] comparison for the timber mullion and transoms for both configurations.....	78
6.17: Timber Schematic for both configurations exposing susceptible areas to dimensional change.....	79

6.18: Condensation analysis potential for vision timber mullion provided by Wufi 2D.....	80
6.19: Condensation analysis potential for intermediary timber transom provided by Wufi 2D.....	81
6.20: Condensation analysis potential for the consecutive stack transom provided by Wufi 2D	81
6.21: Condensation analysis potential for the spandrel timber mullion provided by Wufi 2D	81
6.22: Water Content [kg/m ³] behaviour of the timber frame under both configurations provided by Wufi 2D.	82
6.23: Mould Growth Development & Mould Index [MI] for both façade configurations by Wufi Bio	84
6.24: Cross-Section's schematic simulated in Wufi 2D Motion.....	87
6.25: Schematic of spandrel configurations.	87
6.26: Moisture Content [%] comparison of Mycelium & Isocell insulation under the effect of breathable membrane. Wufi 2D Motion.....	88
6.27: Moisture Content [%] comparison of Mycelium & Isocell insulation under the effect of breathable membrane. Wufi 2D Motion.....	89
6.28: Moisture Content [%] comparison of Mycelium & Isocell insulation under the effect of breathable membrane. Wufi 2D Motion.....	90
6.29: Moisture Content [%] comparison of Mycelium & Isocell insulation under the effect of breathable membrane. Wufi 2D Motion.....	90
6.30: Moisture fluctuations of Configuration A & B against maximum acceptable moisture content for European oak.	93
7.1: Elevation & vertical detail schematic of bio-based façade system proposal. Source: by author.	96
7.2: Schematic of spandrel mullion – horizontal connection. Source: by author.....	97
7.3: Schematic of vision mullion – horizontal connection. Source: by author.....	97
8.1: Life Cycle Assessment Stages according to BS EN 15978. IStructE, 2020	100
.....	102
8.2: Functional Unit and mullion schematic for the three scenarios, Source: by author.....	102
8.3: Mycelium Insulation Process Development - A1 – A3. Source: Modified by Stowa 2019	104
8.4: Anodized and Coated Aluminium Profiles flow chart of production A1 – C4. Source: Modified by AEA	106
8.5: Timber flow chart of production A1 – A4. Source: Modified by L.A Cost srl. 2021.....	107
8.6: Global warming potential total, per element impact for the three façade system scenarios. Source: One Click LCA.	109
8.7: Global Warming potential total by life cycle stage for the three façade system scenarios. Source: One Click LCA	110
8.8: Global warming potential fossil, per element for the three façade system scenarios. Source: One Click LCA.....	111
8.9: Global warming potential biogenic, per element for the three façade system scenarios. Source: One Click LCA.	112
8.10: Global warming potential LULUC, per element for the three façade system scenarios. Source: One Click LCA.	113
8.11: Global warming potential Water usage [m ³], per element for the three façade system scenarios. Source: One Click LCA.....	114
8.12: Total embodied carbon per m ² of façade unit among the three analysed scenarios. Source: by author..	115
9.1: Principles of circular economy. Source: Shikha 2020.....	119
9.2: Kroon Hall, Yale University (left) & The Odgen Centre for Fundamental Physics (right). Source: Arup 2011	120

List of Tables

Table 1: Wood Products Technical Specifications * μ [Dry/damp].....	25
Table 2: Compressive & Tensile Strength of Wood Products	27
Table 3: Durability class description – EN 350.....	27
Table 4: Notional Design Charring Rate	27
Table 5: Bio-based cladding for the timber frame façade panel.....	29
Table 6: Bio-based insulation for the timber frame façade panel.....	30
Table 7: Bio-Based Sheathing board for the timber frame façade panel.....	31
Table 8: Boundary Conditions applied to proposed bio-based cross-sections for heat conduction analysis. Source: National Fenestration Rating Council [NFRC], Therm 7.8 Database.....	57
Table 9: Boundary Conditions applied to proposed bio-based cross-sections for the condensation risk assessment based on the Netherlands weather conditions. Source: Therm 7.8 Database.	57
Table 10: Material properties of the proposed bio-based façade system supported by Therm 7.8 Database.....	58
Table 11: Thermal Performance of proposed bio-based façade system for Configurations A & B.	59
Table 12: Thermal Performance of Aluminium Curtain Wall Façade System	61
Table 13: Boundary Conditions applied to condensation risk assessment analysis in Therm 7.8	62
Table 14: Boundary Conditions used for the simulation of the Bio-based façade cross-sections. Wufi 2D Motion	69
Table 15: Material Properties for the Bio-based façade configurations cross-sections. Wufi 2D Motion	69
Table 16: Mechanical properties of European oak glulam.	75
Table 17: Shrinkage & swelling in [mm] for both facade configurations based on the radial & tangential initial dimensions.....	77
Table 18: Shrinkage & swelling in [mm] for both facade configurations based on the radial & tangential initial dimensions.....	77
Table 19: Analysis Scale set by Wufi Bio according to ASHRAE 160.....	83
Table 20: Input parameters for mould growth analysis provided by Wufi Bio.	83
Table 21: Analysis Scale set by Wufi Bio according to ASHRAE 160.....	84
Table 22: Material properties of spandrel typologies provided by Wufi Database & technical specs from manufacturers.	88
Table 23: Analysis Scale set by Wufi Bio according to ASHRAE.....	91
Table 24: Material Quantities for Aluminium CW System – Scenario 1	108
Table 25: Material Quantities for Bio-based façade system – Scenario 2 & 3.....	108



1. INTRODUCTION

1. Introduction

The construction industry is known for its traditionally conservative approach to decision-making involving building design and construction. This approach can also be recognised in the façade design industry, where the goal has always been to deliver products that are designed for one single lifespan and one single purpose. Unfortunately, the façade lifespan is not necessarily dictated by the expiration or failure of the structural integrity of its components but may be governed by societal and economic factors [Crowther 2018]. As a result, the service life of a façade system, which is defined as the period where the system can be used for its intended purpose without major repairs or replacements, may be lower than its technical life, which defines the period a system can function according to its intended design specifications and performance standards. Therefore, the appearance or functionality of a façade system may determine the expiration of the latter regardless of the optimal performance of its components.

The fast rate of change of the façade production cycle which focuses on construction and demolition has impacted the environment and resulted in soaring waste quantities, high reliance on non-renewable resources, and greenhouse emissions. The fact that buildings are treated as a single entity during the design stage, regardless of the clearly different design lives of the components or layers within the buildings, [Crowther 2018] has even further exacerbated the issue.

All these factors have made the construction industry responsible for approximately 40% of global energy and processed-related carbon dioxide emissions. Within the construction industry, façade design can contribute between 13% and 30% of the initial embodied carbon emissions, which does not take into consideration the overall carbon emissions of the operational and end-of-life phases.

In addition, the construction industry accounts for an estimated third of the world's overall waste, mostly coming from the extraction, consumption, and demolition of raw materials [Dams 2021]

Therefore, searching for more environmentally friendly construction processes, design solutions, and applications that introduce renewable materials as standard construction materials is imperative to reduce the reliance on non-renewable resources, and diminish energy consumption processes.

The application of façade design technologies such as modularity, design for disassembly (DfD), and design for adaptability (DfA) become a relevant solution to merge from a linear design approach centred on production and demolition to a more dynamic one, where the design goal is to create façade systems that can be reconfigured, repurposed, disassembled, and adapted. In this context, it is essential to research and evaluate the incorporation of these methodologies in the search for areas of improvement and continue to innovate sustainable building practices that can meet the standards of the users without harming the environment.

Focusing on a dynamic design approach, this research aims to further investigate the application of bio-based materials in modular façade construction to understand its feasibility from a sustainable and technical performance parameter. The study centres on a comparative analysis where the modular bio-based façade systems performance is measured against standard façade systems to further diminish the reliance on highly embodied carbon materials.

The following chapters will develop in more depth the current development of circular and sustainable façade construction practices and will explain in more detail the applied methodology to this study to research and investigate the application of bio-based materials in modular façade design and construction.



2. RESEARCH FORMULATION

2. Research Formulation

2.1. State of the Art

The building sector, as it stands today, is at a critical moment, confronting challenges posed by unsustainable building practices, linear economic approaches, and the escalating impacts of anthropogenic climate change. Central to these challenges is the design and functionality of building envelopes, which play an integral role in a building's operational energy consumption. The importance of this relationship between façade design and energy consumption cannot be understated, given the great pressure of urban development, changing governmental regulations, and an ever-increasing demand for sustainable solutions. Motivated by these issues, I started a comprehensive literature survey to explore the impact of façade design, sustainable practices, and the potential of bio-based materials in redefining façade construction and design for the future.

The objective of this literature survey was to synthesize and understand the key developments, innovations, and challenges in the sustainable façade design sector, where my focus centred around these questions: How are contemporary regulations influencing façade design practices? What sustainable techniques have been researched to improve energy efficiency and resource consumption in façade construction? And, most importantly, can bio-based materials and modular construction techniques offer viable solutions to the current challenges faced by the building envelope sector?

To conduct an integrated exploration, my approach was twofold. First, I investigated into current building practices, understanding the linear lifecycle of building design, and the resultant environmental implications. My aim was to understand the impact of the reliance on non-renewable materials and the alarming waste cycle. Secondly, I focused on innovative solutions emerging in the industry, particularly the introduction of modular construction and bio-based materials to examine the potential bio-based materials have in redefining façade design challenging the dominance of conventional materials like aluminium, steel, and concrete.

The current linear economy approach to production in the building sector tends to centre on one-life, one-purpose buildings, therefore becoming one of the main contributors to anthropogenic climate change. These perspectives accompanied by the international government's current regulations and the exponentially growing density of urban development have made the industry take measures to introduce more sustainable techniques to building design and construction.

A building's operational performance, which encompasses the energy consumption during the building's operation phase, is responsible for a significant portion of the overall energy uptake in the built environment. Therefore, a special focus has been placed on its reduction. The performance of the building envelope and how it directly impacts the overall operational performance is well-recognized, thus the material selection and design strategies for façade design and implementation have become crucial in overall efforts to reduce the energy uptake in the built environment [Eleftheriadis 2017].

Consequently, the façade design sector has been motivated to develop new technologies and processes to comply with stringent building code regulations and complex technical performances to lower the operational energy consumption of the building.

Unfortunately, such processes have inadvertently increased the use of non-renewable materials which have a high embodied carbon [Hartwell, Overend 2020]. In addition, current design and construction processes as already mentioned are focused on a single purpose, and a single life span of the building envelope, which also increases the difficulty to recover such materials after their first life iteration. Therefore, a dangerous

waste cycle has been established showing a substantial increment in the last decades, thus increasing the effects of pollution, greenhouse emissions, and natural resource depletion, among others.

Due to the importance of the building envelope in the optimal functionality of a building and the critical impact its implementation has on the environment, more sustainable techniques have been researched by the industry to tackle energy efficiency, material consumption, and façade reconfiguration. Among such techniques are the introduction of modular construction and the use of biobased materials instead of the traditional non-renewable materials currently found in the market.

Modularity allows for a more dynamic behaviour in the building sector, aiming to repurpose the building envelope and design facades whose technical service life, related to the degradation of building elements due to natural ageing, is aligned with their functional service life, linked to the expectations, and demands of building users, diminishing waste and resources. [Dams 2021] Therefore, circular construction aims to reduce waste production practices by reusing, refurbishing, upcycling, or recycling materials upon completion of first use, resulting in the circulation of materials in multiple reuse loops [Durmisevic,2019].

Circularity coupled with integrating bio-based materials then becomes a viable solution to tackle climate change by reducing greenhouse emissions and achieving resource efficiency while ending the reliance on carbon-intensive construction materials. Consequently, the construction industry has started to research and implement new materials and design technologies.

Bio-based materials have become an important area of research because of their adaptability and versatility characteristics through biological adaptation. Such characteristics can contribute to the general principle of climatic design which is one of the most efficient procedures to reduce energy consumption in buildings [Hartwell, Overend 2020]. One of the natural resources commonly used and applied in the building sector is engineered wood (Timber). There are currently industrialized engineered wood products that are highly competitive against standard materials such as aluminium, steel, and concrete, among others. The wide range of mechanical properties of the available timber products makes them attractive candidates due to the ability to select different products with different properties based on the application.

Other lignocellulosic material composites that are starting to be introduced in the construction sector, primarily in interior applications or wall insulation are hemp, straw, reed, wool, grass, bamboo, or rattan. Green roofs, green facades, and bio-composites which are formed by natural fibres or bio-resins are also starting to be considered and applied. [Sandak 2019]

According to [Durmisevic 2019] Bio-composite applications are becoming more popular in sustainable façade design and like timber, can become substitute materials for concrete, brick, aluminium, and steel. The most common materials used in bio-composites are natural fibres such as jute, hemp, and kenaf, as well as bio-resins like polyurethane, epoxy, and vinylester. Other examples of bio-composites being used in façade design include biopolyester and twill Bio-tex flax fabrics [Sandak 2019]

One of the advantages of the introduction of bio-based materials is the low environmental impact due to their renewability and cascade use. Such is the case of timber, where the amount of energy needed for its manufacture is significantly low, involving about 10 % of the energy consumption required to produce an equivalent amount of steel. [Odeen 1985]. Biomaterials also allow for prefabrication and fast installation because of their flexibility, making them an optimal candidate for modular applications. In addition, modularity allows for quality control since façade components can be built under precise specifications in a controlled facility. Other benefits are customization, improved efficiency, and greater versatility in design due to the easy reconfiguration of façade components.

However, there are not only advantages to the application of biomaterials and modular design in the building envelope. Its practice currently has knowledge limitations that need to be further researched and analysed. Some aspects to consider regarding the feasibility of bio-based materials and the potential constraints of modularity in façade systems found in literature are:

- **Fire Safety:** Due to the flammability of bioproducts, fire safety is one of the most important parameters to analyse. Fire safety is one of the main barriers to bio-based modular façade design, where the goal is to protect and isolate, if possible, the bio-based materials to prevent fire propagation. [Sandak 2019]
- **Durability:** Bio-based materials may not be as robust as standard construction materials that are often mineral, metal or plastic-based. Natural products can also be more susceptible to biotic agents and weather conditions, which can result in higher maintenance costs. Durability also becomes a boundary condition for façade design since the exposure of bioproducts may be not feasible for application. [Crowther 2018]
- **Cost & Availability:** Limited availability may be an issue with bio-based materials compared to standard construction products. Sourcing, and dimensioning, are important parameters to consider since they influence the implementation of the façade system. The cost of bio-based products may also be a constraint since they may not be as installed and exposed to the market, which may affect their price and cause them to be less competitive against standard materials. [Hartwell 2020]
- **Moisture Resistance:** Bio-products can be sensitive to moisture damage. Therefore, special treatments and/or coatings may have to be implemented. [Cascone 2016]
- **Structural Integrity:** The strength of the bio-based modular façade systems and their behaviour against movements, deflections, and their capacity to withstand loads can be a limitation against traditional materials. Its feasibility needs to be assessed. [Cascone 2016]

Overall, the trend for the next generation of façade systems is shifting, and its focus and functionality are morphing from barrier to interface with the outdoor environment, static to responsive, dynamic, passive-single functional to adaptive-multifunctional, and lastly from conventional to customized concerning the variety and complexity of design approaches, where the overall focus is to enhance the building's performance [Arup 2015]. Therefore, the research of new materials and design technologies that can be implemented in support of such changes becomes instrumental in supporting the evolution of façade systems.

2.2. Thesis Topic

As detailed in the previous section, circular biobased products have the potential to be an optimal solution to reduce reliance on non-renewable materials, lowering greenhouse emissions, and providing building reconfigurations which can limit unnecessary demolitions. Following such concepts, adaptability in façade design becomes relevant to repurpose façade components through a second or third life iteration with the minimum possible impact on their technical lifespan.

Therefore, the focus of circular façade design arises as an approach that facilitates the reuse, recycling, and flexibility of façade components. These benefits are coupled with the aims of lowering costs and reducing the environmental footprint while producing façade units that can be demounted, maintained, upgraded, or remodelled.

To provide that level of adaptability, the enclosed facade panels follow a modular approach for installation to become more accessible for reconfiguration. The façade technology that enables the application of modularity in façade design with a higher degree of freedom is the unitised curtain wall system. They are relevant to modular design due to their prefabricated panel composition which is designed to fit uninterruptedly for protection against atmospheric agents. Such prefabrication and seamless on-site installation allow unitised façade systems to enable greater flexibility in design and easier replacement or reconfiguration of façade components. [Cascone 2016] The technology also facilitates higher quality control standards in the façade components since their manufacturing process can be monitored according to precise specifications.

In addition to the modular façade design, and the optimal suitability of unitised curtain wall systems for design adaptability, the selection within the available range of biobased materials becomes crucial to determine the viability of the façade panels. Traditional unitised curtain wall façade systems depending on the design are typically composed of aluminium frames, which act as structural support for the panel components and add water tightness to the system. Even though the recyclability potential of aluminium has increased through the years, the material faces other constraints such as poor thermal insulation which has an impact on the overall energy performance of the building.

Therefore, searching for more sustainable materials with efficient thermal properties and design technologies that can diminish the use of aluminium in the façade system is the primary aim of this study. Thus, one of the focuses of this research centres on the application of timber framing as part of the unitised curtain wall system. Following the contribution of designing a bio-based unitised panel, other facade components such as insulation, cladding, and sheathing will have a biological nature as well. The goal is to design a façade system with the minimum possible reliance on non-renewable resources and to understand how feasible its composition can be.

Bioproducts also have unique characteristics regarding hygrothermal behaviour, structural integrity, safety requirements, durability, and decaying performance during use. Therefore, it is important to compare the specifications of bioproducts relative to standard construction products. Another principal area of analysis is understanding the reclamation potential of the materials, which measures the ability to recover materials and associated environmental benefits as a function of design [Hartwell 2020]

Opting for bioproducts based on their technical performance, and reclamation potential in integration with circular facade design strategies is a viable approach to address the rising carbon emissions, consumption of resources, landfill waste, and energy consumption for which the building sector is currently responsible.

Therefore, the proposed research study subject is: ***“Feasibility of circular bio-based unitised façade systems”***.



3.

METHODOLOGY OVERVIEW

3. Methodology Overview

The scope of the research is to study through a methodological approach the reusability of façade components considering the demountability, detachability, and adaptability characteristics of a circular and unitised curtain wall facade panel, composed in its majority of bio-based materials through a comparative life cycle assessment against a standard aluminium curtain wall frame. The study will provide an overview of the technical and environmental viability of the proposed system and will identify potential constraints to its implementation and offer solutions to allow its feasibility.

3.1. Design Proposal

As a central part of this research, a design proposal of a bio-based unitised façade panel is executed to allow the analysis of the biomaterials performance and potential constraints that can impact the design freedom of the unitised façade system. The proposal is based on an engineered timber & glazing combination to achieve multifunctionality, high energy efficiency, sustainability, and aesthetics.

The use of renewable materials with low environmental impact and attractive natural appearance, such as timber products, coupled with wide-glazed areas has gained increased interest in modern architecture and is a viable solution for active and adaptive building envelopes. [Kauffman 2018]

The combination of engineered wood and glass promises to offer the benefits of the natural aesthetics of wood with the transparency and brightness of glass. The system is expected to provide improved insulative properties and optimal sound insulation due to the nature of the materials. However, fire resistance is one of the main constraints for this proposal, where the type of wood, glass systems characteristics, and design specifications concerning the spandrel and overall unitised system are crucial.

Design Concept:

The design concept is characterized by the following components:

1. Timber Framing:

The modular system will be formed with a timber framing as the primary building material. The framing will provide the structural support of the building façade by absorbing and transferring movements, deflections, and withstanding loads. The goal of this design is to protect the timber frame from exposure to outer weather conditions to prevent any damage from wetting, moisture, or rot. Timber is a long-lasting material and can withstand harsh weather conditions if properly maintained. Minimizing the weathering kinetics of the timber is relevant in this design to diminish any extra coatings and added maintenance of the material. Also, some areas might be hard to access after the façade system is installed so maintenance may be difficult to achieve. Therefore, the goal of this proposal is to keep the timber framing protected by the external façade components such as cladding and glazing system.

2. Stainless Steel Sheet Coverage:

The starting point of the design proposal includes the addition of a stainless-steel sheet which serves as a coverage for any water and moisture ingress to the timber and the interior of the building. Therefore, the stainless-steel shell will be attached to the timber framing by screws. One of the main functions of the stainless-steel shell is to provide water coverage and to protect the timber frame from exterior weather exposure. Due to the high embodied carbon of the material, its utilization needs to be carefully reviewed to minimise its use, and where used, allow for circular reuse.

3. Spandrel:

The spandrel will be composed of its majority of biobased materials, starting with the cladding, insulation, and sheathing boards. Their selection will be based on durability, aesthetic qualities, thermal performance, and fire resistance. The spandrel can be designed to complement and enhance the aesthetics of the façade system while providing different colours, and textures to the building envelope. Due to their contribution to aesthetics, their design reconfiguration is pertinent to allow façade repurposing.

Following the accessibility to design reconfiguration characteristics, the implementation of a rain screen as a design feature is suitable. Therefore, the spandrel will be designed as a rain-screen, which provides a ventilated gap between the cladding and the breathable membrane which protects the insulation, and other spandrel components. An advantage of the rain-screen concerning the biological nature of the spandrel components is that allows for a controlled drainage and ventilation of moisture that may have penetrated the façade. Thus, helping the bio-based insulation and or timber frame to dry out in case of the presence of moisture. One potential disadvantage to rain-screen implementation in this proposal is the air gap in the rain-screen, which can become a flammability concern because it can provide a pathway for fire to spread to the exterior of the building. Therefore, materials with high fire resistance are beneficial, which can be a challenge with bio-based materials due to their lower fire resistance capabilities.

4. Glazing System:

The choice of glazing systems for the design is being considered and depends on the façade design configuration. One of the parameters to be incorporated in the proposal is adaptability and ease of disassembly to easily demount the glazing pane for maintenance or updates. Therefore, to accomplish that the use of dry glazing systems is preferred over structural glazing.

In the application of the dry glazing system, the glass pane is held in place by a series of toggle connectors or clips that are attached to the frame. Such connectors apply mechanical pressure on the edge of the pane and compress it against a gasket or spacer placed between the glass and frame. [Vigener 2017] This system can be applied with double-glazing units (DGU) and triple-glazing units (TGU). Thus, in TGU systems, additional spacers and clips are required to accommodate the extra weight compared to DGU systems. However, triple-glazing systems have superior thermal performance, increased security, and improved sound insulation compared to double-glazing systems. Therefore, the application of a dry glazing system is a suitable approach to implement in the design.

The goal of the preliminary design concept is to create a bio-based façade system that follows a modular approach for assembly and disassembly while reducing the reliance on highly embodied carbon materials such as aluminium. The first conceptual design as seen in Figure 3.1, uses a stainless-steel sheet localised in the outer section of the timber frame to protect it from direct weather exposure, which already diminishes the reliance on non-renewable resources. However, the objective is to modify it to further diminish the reliance on steel and, if possible, remove the stainless-steel coverage while still providing watertightness to the system, and protecting the timber framing. Further research and analysis of different façade systems, connection strategies, and design specifications need to be conducted at the design stage to arrive at a viable solution.

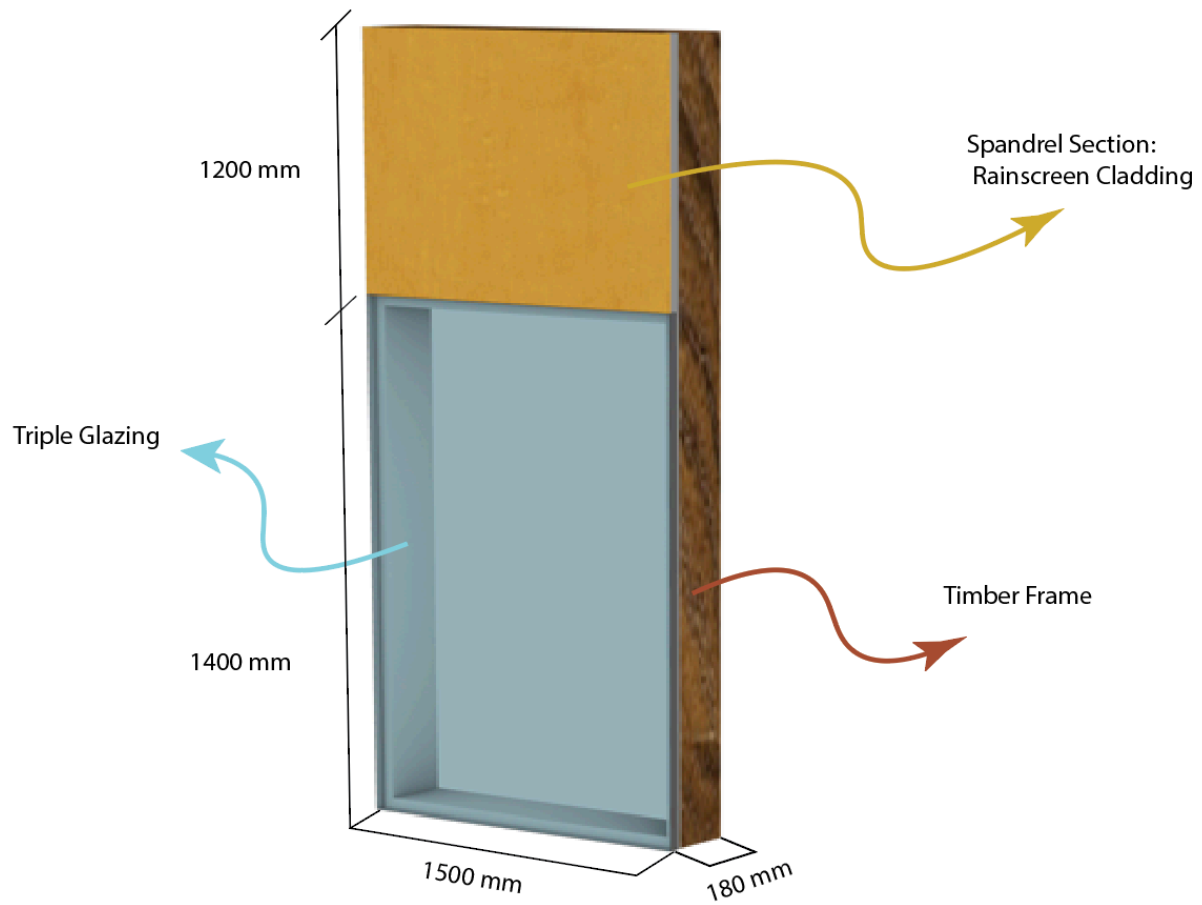

Figure 3.1: First conceptual design of circular bio-based unitised façade system. Source: by author

3.2. Research Structure

The structure of the research involves theory and practice. The first stages of the case study start with a heavy focus on literature research to define the investigation scope and understand the magnitude of the problem statement, analyse current research developments, and identify limitations.

1. Material Study - Bio-based Materials:

The study mechanism at this stage relies on literature research, material specifications, the search for environmental product declarations (EPD), and technical data provided by the material manufacturers. An analysis of the materials based on their mechanical, and physical properties is conducted to make the selection of the more suitable timber framing, insulation, cladding, and sheathing boards.

2. Unitised Curtain Wall System Design - Evaluation & Iterations:

In this stage the focus centres on the creation and evaluation of the preliminary design concept, which is subdivided into three sections as follows.

I. Phase I – Unitised Curtain Wall System Design

The design of the preliminary system is developed and supported by literature research, façade design journals, relevant case studies, and current curtain wall façade systems available in the market. Design methodologies to limit the use of aluminium are studied as well as design mechanisms to create a system that accommodates the constraints given by the nature of the materials. The design is supported by the following tools.

- Revit & AutoCAD to perform and visualize the preliminary unitised curtain wall design.

II. Phase II – Modularity Implementation:

At this phase, the goal centres on the reconfiguration of the panels, type of connections, and assembly accessibility. Design for disassembly and adaptability parameters are followed to promote detachability and reconfiguration.

III. Phase III – Performance Assessment & System Optimization:

To evaluate the performance of the preliminary design, a thermal and hygrothermal analysis is performed to analyse the feasibility of the bio-based design concept. Based on the analysis potential optimization of the preliminary design concept is assessed. The analysis is supported by the following simulation tools.

- THERM 7.8.57, in charge of the calculation of the thermal performance of the system.
- Wufi 2D Motion supports the analysis of condensation risk, mould growth development and moisture content in the system.

3. Circularity & Environmental Impact Assessment:

To assess circularity in the design and understand the sustainability impact of the system a Life Cycle Assessment (LCA) is conducted to quantify the sustainability potential of the bio-based curtain wall system. The software tools used in this stage are:

- One Click LCA, to perform the Life Cycle Assessment of the proposed panel in comparison to the standard curtain wall panel.

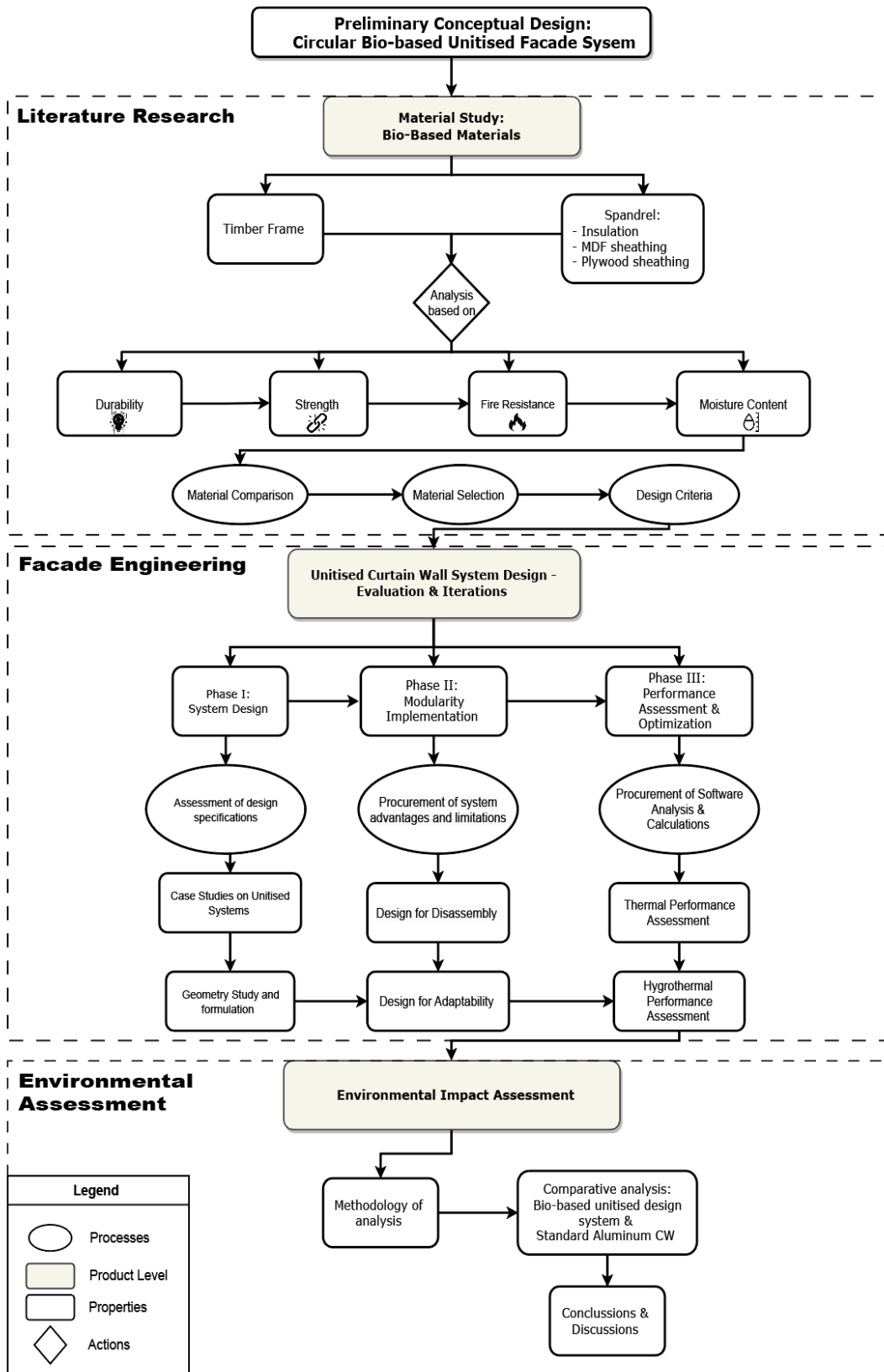

Figure 3.2: Methodology Layout, Source: by author

3.3. Research Questions

According to the research methodology, the main goal of this investigation is to analyse the feasibility of applying bio-based materials in façade design and construction with a focus on adaptability and reconfiguration to further lower the reliance on carbon-intensive construction materials and to diminish the soaring waste–landfill cycle. An environmental impact assessment is also performed to quantify and compare the potential benefits and constraints of circular bio-based unitised façade systems.

Therefore, this research aims to answer the following research questions which capture the main parameters of this study. The following questions are divided into main and secondary, with the central focus on the viability of the proposed bio-based design system from a technical, operational, and environmental perspective to then analyse potential constraints of implementing biomaterials in façade design and construction.

- **Main Research Questions:**

1. *What is the feasibility of introducing circular bio-based façade systems against standard aluminium frame curtain wall systems in terms of environmental impact, lifespan iterations, and operational performance?*
2. *Can a bio-based unitised curtain wall façade system be implemented without the reliance on aluminium or any other carbon-intensive materials?*

- **Secondary Research Questions:**

3. *What are the constraints bio-based materials bring to the design of unitised curtain wall systems? And what measures can be taken to address them?*

3.4. Research Objectives

The main objective of this research is to analyse and understand the viability of introducing circular bio-based façade systems in the building sector as an efficient approach to enhance the adaptability and reconfiguration of façade components while maintaining optimal thermal performance and lowering the reliance on standard non-renewable materials.

1. Objectives at the circular bio-based unitised system level are:

- Establish a clear recovery route for the circular biobased façade products after their first life iteration through their reuse/recycle and recovery phase to diminish material waste.
- Quantify the environmental benefits of introducing an LCA analysis in the early façade design stage.
- Determine the operational and environmental benefits of applying modularity in the façade system.

2. Objectives at the curtain wall system level are:

- Determine if unitised curtain wall systems can comply with technical and structural performances while using biobased materials within their composition.
- Formulate a design façade design proposal where the approaches for design for disassembly (DfD) and design for adaptability (DfA) are successfully attained and a feasible circular bio-based unitised façade system is achieved.
- Design a unitised façade system where the reliance on aluminium gets further diminished.

3. Objectives at the level of the biobased materials are:

- Understand the capabilities of biobased materials as efficient construction materials against the standard high embodied carbon material currently used in the market.
- Analyse and research the current biobased material options to help standardize their usage in the building sector.
- Analyse current applicable technologies if any to enhance durability and fire safety measurements in biobased materials.



4.

MATERIAL STUDY: BIO-BASED MATERIALS

4. Material Study: Bio-based Materials

The focus of this chapter is to analyse potential bio-based material options to encompass the façade design proposal. Bio-based materials, derived from renewable resources, offer multiple advantages over traditional construction materials, ranging from reduced environmental impact to improved energy performance and aesthetic appeal.

Obtained from natural sources such as plants, fungi, algae, and bacteria, these materials can be both naturally occurring or engineered to enhance specific technical and mechanical properties. However, there can be some limitations due to their organic nature, that need further investigation, such as fire resistance, biotic decay, and moisture exposure. These factors are further investigated in this chapter to understand the feasibility of bio-based materials in the built environment and bring to light design optimization parameters to benefit their performance.

Within the bio-based material research, special attention is given to timber as an ideal building material because of its optimal tensile and compressive strength, high strength-to-weight ratio, and easy workability. In addition, timber plays a key role on both sides of the net zero balance since it acts as a carbon sink by storing carbon throughout its growing phase and it is also less carbon-intensive to manufacture, transport, and assemble compared to steel, and concrete structures. [Arup 2019]. Therefore, increasing its application can significantly reduce the current severe carbon impact caused by the construction industry.

The timber industry has experienced significant growth in the last decade, predominantly because of the increase of engineered timber products such as cross-laminated timber, glue laminated timber, and laminated veneer lumber, which are designed to cater to specific needs, thus increasing the range of applications they can serve.

Therefore, the introduction of bio-based materials in the built environment comes as a mitigation strategy to the current anthropogenic damage caused by the exponential densification of urbanisation and the pressure to cater to a human population growth which is negatively impacting the planet's resources. Thus, changing the reliance on traditional carbon-intensive materials is imperative, and understanding the properties, advantages, and disadvantages of bio-based materials is key to switching to more sustainable design and construction processes.

The analysis of this chapter is divided into two categories of façade components, starting with an investigation of the different solid and mass timber products to choose the most suitable option for the timber framing, followed by the study of bio-based insulation materials, cladding, and sheathing boards to conform the bio-based spandrel.

4.1. Timber Framing Material Selection

To select the most suitable material for a timber frame, several factors need to be considered. To simplify the analysis, a brief description of the more used engineered wood products and solid woods has been included in the research. Their mechanical and physical properties have been included to analyse their suitability. Production processes, advantages, and disadvantages have also been listed to help the analysis.

1. Sawn Timber

It is a branch of solid timber, where the wood hasn't been exposed to any modifications preserving its natural structural form. Sawn timber is produced by sawing logs longitudinally and refers to products made from logs in sawmills. Sawn timber products are grouped according to their cross-sectional dimensions and can be categorized as planks, battens, and square timbers.

- **Hardwoods:**

Hardwoods are defined as angiosperms, which are the type of trees characterized by the presence of flowers and leaves and produce seeds with a coating in the form of a fruit or a shell. They also have a more complex cellular structure with visible pores and vessels used for nutrient transportation than softwoods, and in general, hardwoods have greater hardness than softwood species. [Juaristi 2022] Due to the molecular structure, hardwoods tend to be denser and heavier products, which influences their durability. [Kauffman 2018] Because of their density, and the reduced air pockets in their wood fibres, hardwoods have a better performance against flammability. Another quality of hardwoods is their resistance to decay and insect damage, which makes them a suitable option for outdoor applications.

- **Softwoods:**

Softwoods are classified as gymnosperms, meaning their seeds are not enclosed in a fruit or shell. They are typically considered evergreen trees such as coniferous trees which have needle-like or scale-like leaves. Softwoods have a more homogenous cellular structure and are formed with ray cells compared to pores and vessels like hardwoods. Such molecular structure makes the material less dense and lightweight, which also affects its strength, making it less durable than hardwoods. [C.Sandhass 2017] One quality of softwoods is their workability since they are generally easier to work with and shape, which makes them an interesting candidate for a broader range of applications.

- **Strength Grading:**

Wood as a natural raw material is produced from a wide range of trees depending on their type, genetic material, growth, and environmental conditions. Therefore, grading is a mechanism that tries to categorize tree species and wood products based on their mechanical and physical properties. However, wood characteristics from tree to tree from the same species may be very diverse, even from the same stem, stem cross-section, and longitudinal stem direction [Timber Engineering Book] Therefore the strength grading criteria try to include all the limit values for wood characteristics, which correlate sufficiently with actual strength and stiffness of the wood. The strength grading categorizes the wood and wood products depending on their load-bearing capabilities. In Europe, the classification follows the standard EN 338 for softwoods (C-class) and hardwoods (D-class). Starting with the weakest softwood: C15 to the strongest softwood: C50 and from the weakest hardwood D18: to the strongest: D70. The grading of the materials also helps to identify other mechanical properties such as Modulus of Elasticity, density, and tensile strength, among others.

The definition of softwoods, hardwoods, and their grading characteristics is important to help distinguish among the biological characteristics of unmodified wood. This knowledge can then be translated to understand the different properties and characteristics of engineered wood products and assess the selection of the most suitable material for the timber framing.

2. Engineered Wood Products

Wood is an orthotropic material due to its different mechanical properties associated with its axes of symmetry. Therefore, engineered wood products are created to homogenise the material and cater to specific properties and characteristics. [Tapparo 2017] Engineered wood products are then a composite made by bonding together wood fibres, lamellas, veneers, strands, or particles with adhesives to manufacture and enhance their mechanical properties. For façade applications, engineered wood, most specifically, glue laminated timber, laminated veneer lumber, and cross-laminated timber have become suitable options as structural timber due to their improved characteristics such as strength, stability, and durability. [Tapparo 2017]

○ **Glued Laminated Timber (Glulam)**

Glulam is a type of timber where all the lamellas are arranged parallel to the grain. Therefore, the grains of all the laminations run parallel along the length of the product. Their production involves gluing over the entire contact surface of finger-jointed sawn boards with adhesives which results in rigid connections. One important development of the product is the type of adhesive used, which is a synthetic resin, that provides waterproofness and mildew resistance. [C.Sandhass 2017].

Advantages	Disadvantages
Larger cross-sections are a possibility	Glulam needs to be visually and mechanically graded. Quality control of glulam is highly dependent on the manufacturer, and it may be more difficult to achieve consistent quality
Less prone to warping, cracking, and splitting than solid wood.	Glulam can be heavier than other engineered wood products.
Risk of localized damage gets reduced due to stress distribution during the bonding process	Cost may be a potential constraint for the use of glulam. The material can be more expensive than concrete or lumber.
Shape and size versatility	
Mostly used in constructions exposed to bending strength	

○ **Laminated Veneer Lumber (LVL)**

Laminated veneer lumber is produced using rotary-cut softwood or hardwood veneers of about 3 mm thick glued together with phenol resin as an adhesive. The fibre direction of the veneers can be parallel to the longitudinal direction and slightly perpendicular (up to around 25 %) to the longitudinal direction of the laminated veneer lumber. [C. Sandglass 2017] They are usually used as a load-bearing beam or load-bearing sheathing material.

Advantages	Disadvantages
Due to its composition, the material is highly homogenous, therefore is a very reliable material.	LVL can be difficult to work with due to the potential separation of thin veneer layers if not cut properly
Vertical loads are optimally transferred	Can be more expensive than other engineered woods
Peeling cracks in veneers allow entire cross-sections of LVL to be easily impregnated if necessary.	May not be as resistant to moisture and rot compared to solid wood. Difficulty to stain or curve, which makes it a good option for a structural framing that won't be visible.

○ **Cross Laminated Timber (CLT)**

Cross Laminated Timber is a structural wood material, which is always used for load-bearing applications. It comprises multiple crosswise-arranged board layers. Their fabrication is composed of gluing layers, which are completely or partially filled with solid-sawn lumber boards. The adhesive used is usually melamine resins or polyurethane (PUR).

Advantages	Disadvantages
High strength and dimensional stability in both directions.	More expensive than traditional wood
Good charring qualities	Requires specialized construction experience
Shape and size versatility	
Material configuration reduces swelling and shrinking	
Optimal thermal, acoustical, and seismic performance	

○ **BauBuche**

BauBuche is a structural laminated veneer lumber made of hardwood, more specifically beech. Veneers are predominantly aligned parallel to the grain to give a main load-bearing direction. The adhesive used for gluing the veneers is phenolic resin, which is a synthetic polymer obtained by the reaction of phenol with formaldehyde.

Advantages	Disadvantages
Greater load-bearing strength than LVL made with softwoods	Extremely sensitive to moisture, affecting its serviceability.
Superior surface quality	Due to high density, it is a heavier material compared to other engineered wood products.
Locally sourced from sustainable forests.	Even though impregnation is a possibility. Its application and effectiveness on BauBuche are still in development
Due to its higher density and strength, reduces dimensions and cross sections in timber construction	Very high cost compared to other engineered products
Compressive strength life concrete C50/60	
Beams are sanded so ideal for exposed applications.	

○ **Accoya**

Accoya wood is made from Radiata Pine harvested from sustainable forests. It is a type of timber that has been chemically modified by the process of acetylation, which enhances its durability and biological decay. Therefore, Accoya has a higher resistance to outside exposure. The process of acetylation involves modifying the wood's cellular structure, more specifically the free hydroxyl group, which is in charge of absorbing and releasing water. The process involves introducing acetic anhydride to bind with the hydroxyls and block the water absorption of the material. Moisture absorption is the primary reason for shrinking and swelling.

Advantages	Disadvantages
Very resistant to biological decay	Very high cost compared to other engineered products
Material is highly stable and durable.	

Highly resistant to rock and insect attack

Very versatile and good acceptance to coating applications

3. Selected Timber Framing Options

Based on the presented information on wood species, production processes, and construction applications in the market, the following timber products have been selected for analysis.

1. Norway Spruce Glulam – Manufacturer: Moelven Töreboda
2. Larch Glulam – Manufacturer: Rubner Holzbau
3. Oak Glulam [Vigam] – Manufacturer: Grupo Gamiz
4. BauBuche [Spruce Laminated Veneer Lumber] – Manufacturer: Pollmeier
5. Accoya [Acetylated Pine Radiata] – Manufacturer: Accoya
6. Kerto LVL – Manufacturer: Metsä Group
7. Spruce CLT – Manufacturer: Rubner Holzbau

The following table describes mechanical, technical, and physical parameters to further analyze the materials.

Material	Bulk Density/ Specific Weight [kg/m ³]	Moisture Content [%]	Bending Strength <i>F_{m,k}</i> [N/mm ²]	Thermal Conductivity λ [W/m-K]	Service Class	Durability [EN 350:2]	Flammability Classification
Norway Spruce (Pressure Impregnated) Glulam	430	12 -15	28 32	0.13	SC1, SC2, SC3	DC5	D s2 d0
Larch Glulam	464	12 +/-2	24 28 32	0.13	SC1, SC2, SC3	DC4	D s2 d0
Oak Glulam	690	12 +/-2	33	0.16	SC1, SC2*	DC2	D s2 d0
BauBuche	800	6 +/-2	75	0.18	SC1, SC2	DC5	D s2 d0
Accoya	515	3 – 5	16 22	0.12	SC1, SC2, SC3, SC4	DC1	D s2 d0
Kerto LVL	510	8 – 10	Edge 44 Flat 50	0.13	SC1, SC2	DC5	D s1 d0
Spruce CLT	480	11 +/-3	24	0.13	SC1, SC2	Not specified	D s2 d0

Table 1: Wood Products Technical Specifications * μ [Dry/damp].

4. Analysis:

The timber framing in the façade system carries an important role since it provides the structural support to absorb and transfer movements and deflections and resist dead and live loads. Therefore, the mechanical characteristics such as bending, tensile, and compressive strength are important to analyse. However, there are other important functionalities that the framing needs to comply with that are relevant to mention. The framing even though will be protected against weathering exposure, it needs to have high durability, to be able to withstand reconfiguration through different life cycles. Another important parameter to consider is the fire classification and the charring rates of the material. Lastly, other properties relevant to the analysis are moisture content, density, and biogenic content to understand the behaviour of the material against shrinking and swelling, and the carbon sequestration quantities it can store.

The first boundary condition of the proposed materials is the bending strength, compression strength, and tensile strength. Strength grading is an important feature of the material since it influences the end use and functionality of the wood product. Bending strength or flexural strength is the ability of the material to withstand bending or flexing without breaking, which is relevant for the material analysis since it will be subject to bending loads. Therefore, based on a bending strength comparison as seen in Figure 4.1, the wood products that have higher bending strength values are Oak Glulam [GL 33], Beech LVL (BauBuche)[GL75], and Kerto LVL, made from Spruce and Birch [LVL 48 P].

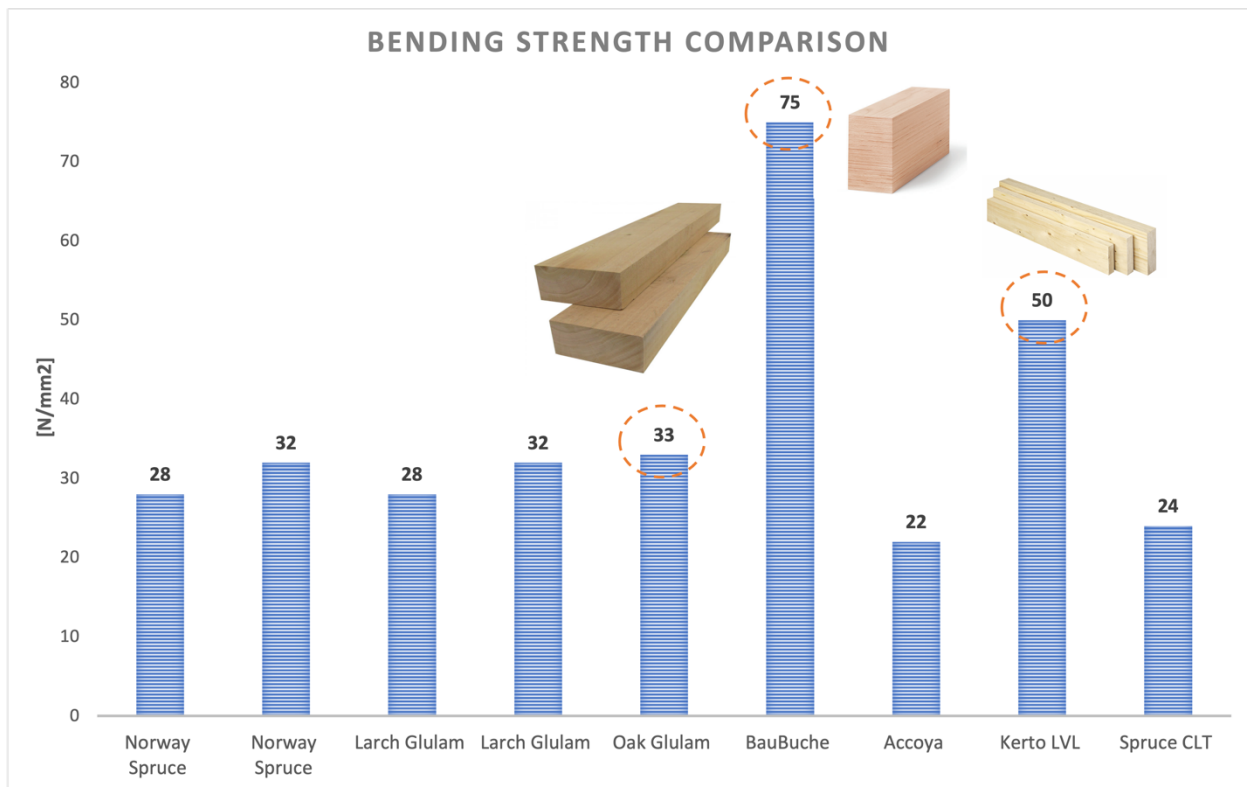

Figure 4.1: Bending Strength [N/mm²] comparison among wood products.

The compressive and tensile strength which measures the material's ability to resist compression and stress forces without collapsing or fracturing is also analysed. Due to the anisotropy of the materials, the tensile and compressive strength is measured parallel and perpendicular to the grain. The highest values are following the direction parallel to the grain.

Wood Products	fc,0,k [N/mm2]	fc,90,k [N/mm2]	ft,0,k [N/mm2]	ft,90,k [N/mm2]
BauBuche	49,5	12,3	60	0,6
Oak Glulam	45	8	23	0,6
Kerto LVL	35	6	35	0,8

Table 2: Compressive & Tensile Strength of Wood Products

From these values, it can be denoted that the material with the highest tensile strength is BauBuche, then Kerto LVL, followed by Oak Glulam. Now analysing, the compressive strength, the material with the highest values is BauBuche, then Oak, and lastly Kerto LVL. BauBuche as it can be seen is a very strong material. However, Oak Glulam shares almost the same values in compressive strength parallel to the grain, with a difference of only 10 % while Kerto, with a difference of 30 %. The proximity of Oak Glulam to BauBuche in compressive strength is because of the composition of Glulam. The latter is manufactured of lamellae positioned parallel to the grain following the fibril cells composed of lignin, which is an organic polymer that contributes to the strength of the material. [C.Sandhass 2017]. Since BauBuche, Oak Glulam, and Kerto LVL are the materials among the selection with the highest bending, compressive, and tensile strength. Therefore, other of their material properties need to be analysed to make a selection.

In the building context, the mechanical properties of engineered wood are the most important characteristics as a structural material, and they are influenced by environmental factors. Changes in moisture, material decay, and fire can significantly change strength properties. Therefore, analysing the durability of the material is a relevant factor of analysis. Durability classification is a parameter established by EN 350 that measures the natural durability of wood species against biological decay. BauBuche and Kerto LVL have a DC 5, and Oak Glulam DC2, which means that Kerto and BauBuche are materials susceptible to wood pests such as fungi. Therefore, special coatings or treatments need to be performed to protect the material.

Durability Class	Description
DC1	Very Durable
DC2	Durable
DC3	Moderately durable
DC4	Slightly durable
DC5	Not durable

Table 3: Durability class description – EN 350

Fire Classification is another category to analyse because of the biological nature of the materials. The combustibility of building materials particularly influences the spread of fire after it breaks. However, mass timber such as Kerto, BauBuche, and Oak Glulam due to the dense structure can withstand fire longer without getting ignited and spreading fire. Thus, analysing the fire resistance or charring depth of the materials is important. The charring depth is the distance between the outer surface of the original member and the position of the char-line. [Metsä Group]

Material	Notional Design Charring Rate [mm/m]
Oak Glulam	0,55
BauBuche	0,7
Kerto LVL	0,7

Table 4: Notional Design Charring Rate

In this analysis, Oak glulam has a better charring rate compared to BauBuche and Kerto, since the susceptibility of the material to burn per millimetre is advancing at a slower rate.

The ability to sequester carbon is measured by the biogenic carbon content, which is an important feature to consider in this proposal because of the modularity approach to the design, and the goal to extend the service life span of the materials through different lifecycle iterations. The wood product with the higher biogenic content is BauBuche with 1.171 kg/m³, while Oak Glulam and Kerto LVL have 800 kg/m³ and 783 kg/m³ respectively.

Another important parameter to analyse is bulk density. It is identified as the ratio of mass to volume and as the wood's density increases its strength also increases while the deformation under compression decreases. For fire resistance parameters, wood products with higher densities tend to have better resistance. Following the materials analysis, BauBuche has the highest density with 800 kg/m³, followed by Oak Glulam; 690 kg/m³, and Kerto; 510 kg/m³.

Another important factor that gets impacted by density is the moisture content. Even though other parameters influence the moisture absorption and desorption behaviour, as the material's density increases, fewer voids exist in its structure. Therefore, less moisture in its matrix. Moisture content is a key parameter to analyse due to the hygroscopic nature of wood. Within, the three chosen materials, Kerto has an initial moisture content of 8 -10%, BauBuche 6 %, and Oak glulam 12 %. Since the material is going to be exposed to climatic changes, it is beneficial to have a higher initial moisture content than a lower one. This is because when the material gets exposed to the surrounding air, if the material has a low initial moisture content and, in its attempt, to attain equilibrium, it will have a higher absorption capacity. Thus, potentially causing damage to the material. Even though oak has a relatively low moisture content for outer exposure, it has the highest among the three. In addition, it is a highly dense and durable material, which makes it a good candidate.

Overall, each of the materials has strong characteristics and weaknesses, BauBuche is the material with the highest bending, compressive and tensile strength among the three but its durability against biological decay is very low compared to Oak Glulam. Also, the charring rates for BauBuche were below Oak Glulam's. Kerto LVL has also strong bending and tensile strength, but its compressive strength parallel to the grain is not as optimal as Oak Glulam's falling behind by 30 %. The compressive strength parallel to the grain is an important parameter to apply to timber framing because the latter will be subjected to loads and stresses and will benefit from a material that is designed with its strongest compressive strength parallel to the length of the beam. Therefore, allowing the freedom to place the beams according to the orientation that the loads are being received.

Other parameters that haven't been discussed but are important to consider because of the nature of the façade design, are workability, weight per meter squared, and cost per meter squared. Oak Glulam has better workability and better shape retention compared to Kerto LVL and BauBuche, also BauBuche is heavier, which can be an issue for installation and disassembly purposes. Regarding cost, BauBuche is the most expensive of the three while Kerto LVL is the cheapest option of the three.

Overall, after analysing all the material features it can be concluded that Oak Glulam is the most suitable choice for the timber framing. The fact that the material is considerably light compared to BauBuche but still has strong compressive strength values is an important characteristic for framing applications. In addition, the durability of the material makes the maintenance of the material less of a concern but an advantage. Lastly, the charring rate of the material was the lowest among the three without any fire retardant, which if applied can even improve the fire safety of the façade system.

4.2. Spandrel Material Selection

- **Bio-Based Cladding**

Fundermax HPL Compact Exterior Panels:

- Process & Composition: The phenolic façade panels also known as high-pressure laminate (HPL) panels are made with layers of kraft paper that are impregnated with phenolic resin. A decorative layer is added before the materials are pressed into highly durable non-porous panels which can be used for interior or exterior purposes.
- FSC and PEFC certified.
- Colour Retention: Good Colour Retention

NeoTimber Composite Cladding

- Composition: Made of recycled plastics and recycled wood fibres
- Not 100 % bio-based

ThermoWood – Radiata Pine

- Process: Thermal modification process in wood structure, improving durability and resistance to outdoor conditions. Chemical free.
- Colour Retention: Aging to grey/brownish colour. Coating recommended.

- **Selection Criteria:**

The bio-based cladding was chosen based on the fire rating of the material. It can be challenging to find optimal fire ratings in bio-based materials. Even though it is still a low value for a façade component. It is a good starting point.

An advantage of the product is the design variability, which has a big effect on the aesthetics of the façade. Other important parameters were lifespan and durability which are competitive values against other materials.

Material	Thickness [mm]	Thermal conductivity λ [W/m-K]	Density [kg/m ³]	Durability [EN350:2]	Fire Rating	Life Span [years]
Fundermax Compact Exterior	8	0,3	1350	DC1	B-s2-d0	40 -60
Thermo Wood Radiata Pine	19	0,107	~660	DC2	D-s1-d0	~30
Neo Timber Composite	10 15	0.1	1350	DC1	B-s2-d0	~60

Table 5: Bio-based cladding for the timber frame façade panel

- **Bio-based Insulation**

Isocell Cellulose Insulation

- Composition: recycled cleaned unmixed newspaper. Coarsely fibered, mixed with mineral salts, and ground in a mill.
- Cellulose has capillarity conductivity which means it absorbs any moisture that forms and acts against the direction of diffusion. Moisture buffer. Does not accumulate mould.
- Blown-in Application
- Fire Protection REI 90
- Fire Retardants: Boric acid, sodium borate (borax), and ammonium sulfate
- PEFC certified.

Mycelium Insulation

- Composition: rigid insulation made of mycelium, defined as a vegetative filament root structure of mushrooms. Mycelium breaks in organic and synthetic substrates that are by-products or wastes of other industries to create the insulation panels. The manufacturing process of mycelium products is estimated to be carbon-negative sequestering at least 16 tons of carbon per month.

Hemp Flax Thermo

- Natural flexible insulation made from hemp and jute fibres. Rodent and insect-resistant
- Composition: Carbon-negative hemp, recycled coffee, and cocoa bean sacks.
- Application: ceilings, loft/roof, walls (timber frame)

- **Selection Criteria:**

Fire resistance for bio-based insulations is so far the greatest constraint for its implementation. Most bio-based insulation boards, which are made from hemp, flax, jute, or wool regardless of their optimal thermal performance achieve a fire classification E, which is unfavourable. Cellulose insulation is a good alternative because its fire rating is improved to achieve REI 90, showing an advantage over its counterparts. Other benefits of the material are dimension variability and optimal thermal conductivity.

Mycelium insulation is another attractive solution because of its competitive fire resistance but also due to its optimal sound insulation and the fact that its production is carbon negative sequestering at least 16 tonnes of carbon per month [Biohm]. Also, it is a rigid material compared to the chosen loose cellulose insulation, thus further analysing the feasibility of both insulations is important for this case study.

Material	Thickness [mm]	Density [kg/m ³]	Fire Classification	Thermal conductivity λ [W/m-K]	Vapor Diffusion resistance factor [μ]
Isocell Cellulose Insulation	120	50	B s2 d0	0,038	1.8
	140	50			
	160	50			
Mycelium Insulation	50	80	B s2 d0	0,03	48
	100				
	150				
Hemp Flax Thermo	40	37	E	0.039	3

Table 6: Bio-based insulation for the timber frame façade panel

- **Bio-based Structural Sheathing Board**

Swiss MDF SF -B

Flame retardant MDF for non-load bearing.

- Composition: Uniform high-quality fibres extracted from pulped fresh wood chips. The melamine urea formaldehyde (MUF) resin is used as the adhesive enriched with a flame retardant.
- FSC & PEFC certified.

ECO OSB 3

The high-performance wood-based panel is structured with three layers of long-wood strands bonded with formaldehyde-free resin applied under high temperature and pressure.

- FSC & PEFC certified.

- **Selection Criteria:**

An MDF sheathing board has been included in the spandrel design to protect the insulation and add fire protection while trying to seal the spandrel from the inside. The MDF was chosen also based on their fire classification and dimension availability.

Material	Thickness [mm]	Weight [kg/m ²]	Density [kg/m ³]	Thermal conductivity λ [W/m-K]	Fire Classification	Moisture Vapor Diffusion resistance factor [μ]	*Cost [€/m ²]
SwissMDF SF-B*	12 16 19 22	~12.6	850	0,09	B s1 d0	-	60
ECO OSB/3	18	17.5	600	0.13	D s2 d0	150-250	~12

Table 7: Bio-Based Sheathing board for the timber frame façade panel



5. UNITISED CURTAIN WALL SYSTEM DESIGN

This chapter encompasses phases 1 & 2 with an emphasis on literature research for façade typologies, dynamic design features and state-of-the-art bio-based façade development. Thus, the gained information is used as a foundation to develop the preliminary bio-base design concept.

5. Unitised Curtain Wall System Design

5.1. Standard Aluminium Curtain Wall System

The Curtain Wall System is typically characterised by the vertical external components of a building, which are designed to safeguard the occupants and the structure itself from the effects of external environmental conditions. Integral to its design the curtain wall system's main function is to withstand air and water infiltration, assuring the building's interior remains impervious to external weather exposure.

This protective enclosure is composed of non-structural walls or panels that are securely anchored to the building structure and do not carry the loads of the building's floors or roofs, but solely support their own weight. However, the system is designed to mitigate sway induced by wind and gravity loads that the building encounters, by effectively transferring them to the building's primary structural system.

The non-structural nature of this system allows the utilization of lightweight materials in its composition, often comprising aluminium framed walls that contain infills of glass, metal panels, or thin stone elements, which as a result facilitates the reduction in construction costs. Aluminium is mostly used not only because of its lightweight compared to other materials such as steel or concrete but also due to its mechanical, and physical properties. Aluminium's malleability, and flexibility make it a versatile material since it can be cast, melted, formed, machined, and extruded in a variety of shapes, thus allowing its suitability to a wider variety of applications.

Aluminium curtain wall systems can be traced back to the 1930s, gaining momentum in the aftermath of World War II as the availability of aluminium expanded for non-military applications. Since that period, the use of this system has surged mostly in the middle of the 20th century, due to the close association with the modernist movement in architecture [Whole Building Design] The latter is marked by the application of minimal ornamentation, panel repetition, and a prominent incorporation of glass which is aligned to the core of the design of curtain wall façade systems.

In terms of classification, curtain wall systems are generally divided into two primary categories, which are distinguished based on their fabrication and installation methodologies. These encompass the unitised or modular systems and the stick systems, each with its unique attributes and their pros and cons.

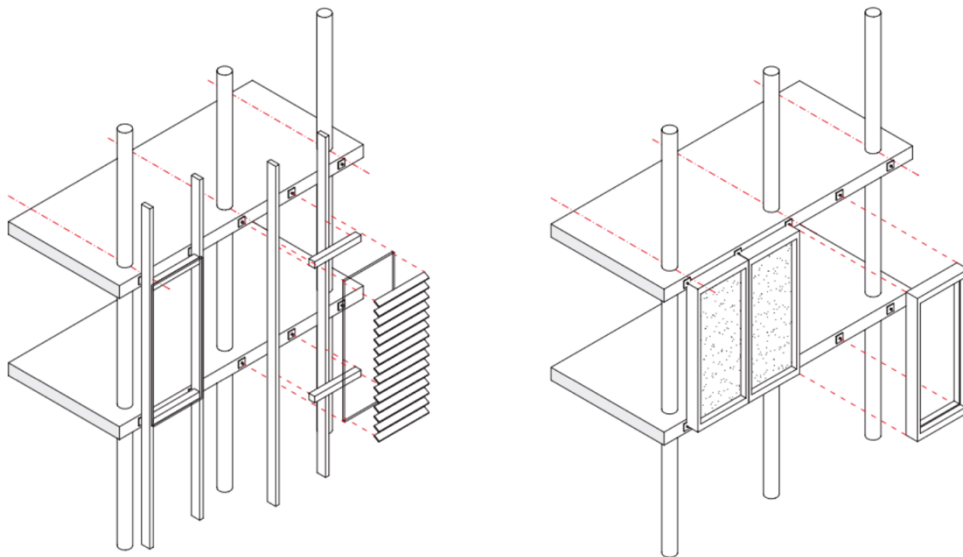

Figure 5.1: *Stick system curtain wall typology (left), and unitised curtain wall system (right). Source: Ulrich Knaack, 2007.*

5.1.1. Stick System:

Stick systems in curtain wall architecture consist of individual vertical and horizontal spanning elements, commonly referred to as mullions and transoms. These components are typically prefabricated in a factory setting where they are cut to the requisite length and prepared for assembly. Following fabrication, these elements are then shipped to the construction site as a knock-down kit. Installation is subsequently carried out by a team of specialized contractors.

The initial phase of the installation involves erecting the grid formed by the mullions and transoms. Following this setup, the glass panes and spandrel panels are integrated into the structural framework. These elements are securely positioned and held in place using a variety of mechanisms such as pressure plates, cleats, toggles, or simple pins. To complete the functional aspect of the installation, these securing mechanisms are finished by the addition of cover caps, thereby ensuring not only structural integrity but also waterproofness.

Advantages:

- It allows site adjustment and flexibility in sudden design changes.
- Economic method to install curtain walling.
- Lower costs to transport materials to the site.
- A reliable method to install complex systems that can't be prebuilt.
- The lead time tends to be shorter for fabricated materials to be delivered to the site allowing for less up-front staging.

Disadvantages:

- Slower and longer assembly period due to the large list of job site activities.
- The installation process is exposed therefore is vulnerable to uncontrolled weather conditions and labour skills.
- Need more space for installation and storage of materials on site, which can be a difficulty in high-traffic cities.
- Can be more challenging to achieve good thermal performance due to the need for carefully sealing and insulating the different components during assembly.

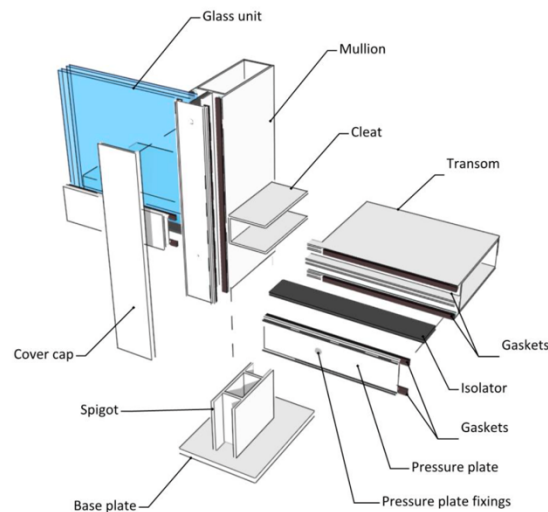

Figure 5.2: Stick system's components with a button cleat connection. Source: Glass Curtain Wall Systems.

5.1.2. Unitised System:

The unitised system is characterized by its utilization of prefabricated units or modules, which are fully assembled within a controlled factory environment before being transported to the construction site for installation. Unlike stick systems, which require on-site assembly of the different components, unitised systems arrive on-site pre-assembled, thereby simplifying the installation process.

Typically, the installation of unitised systems is executed on a floor-by-floor basis, employing male and female interlocking jamb extrusions to secure the modules in place. Therefore, reducing the assembly process.

In terms of dimensions, these modules are commonly designed to span the height of one story and the width of one module. However, configurations may vary, and it is not uncommon to encounter designs that incorporate multiple modules into a single unit. This modularity lends itself to both design flexibility and ease of implementation, thereby making unitised systems an increasingly popular choice in contemporary curtain wall architecture.

Advantages:

- Façade panels can be installed without scaffolds since they can be positioned from the interior of the building.
- Safer installation process compared to traditional façade construction methods.
- Due to prefabrication, higher quality control and finish are achievable.
- Reduction in site-sealed joints and stricter tolerances contribute to improved air and water tightness.
- Speed in installation is usually a third of the time when compared to stick systems.
- Design freedom due to prefabrication.
- Modularity and façade reconfiguration due to independent unit construction and assembly.

Disadvantages:

- Transportation costs are higher than stick-built systems.
- Lead times are often longer due to the prefabrication of panels.
- More expensive due to the increased cost of prefabrication units
- Lifting equipment needed to install units on site.
- Requires more time and planning – off-site for manufacture and shipping.
- Curtain wall panels may not always fit within the space that is assigned in the design stage due to different tolerances within the system fabrication.

Curtain wall systems, depending on their specific methods of fabrication and installation, present a range of advantages and disadvantages. For this case study, the scope of the research is directed towards unitised systems as the construction method of choice. This is because the system enables prefabrication of the façade panels and faster installation on site.

Pre-fabrication of the façade panels not only offers improved quality control of the façade system but also offers a high degree of flexibility and design freedom due to customised shapes and dimensions.

By assembling façade panels in a controlled factory environment, manufacturers can adhere to stringent quality criteria, thereby ensuring a robust and reliable façade system.

Another important aspect enhancing the suitability of unitised systems to the proposed design concept is the system's compatibility with modular construction approaches. This feature renders the façade system easily detachable and highly adaptable for reconfiguration and maintenance, thereby extending its functional life and adaptability.

Overall, curtain wall systems, and unitised systems, in particular, offer several advantages. These systems are conducive to achieving state-of-the-art aesthetics, enabling unlimited natural lighting, and maximizing transparency, which are attributes aligned with the goals of the proposed design concept.

5.2. Current Bio-based Façade Systems

Conventional construction materials often have a high carbon intensity, which has an adverse environmental impact. Therefore, the use of renewable and less carbon-intensive materials in façade design and construction presents an opportunity to mitigate the anthropogenic environmental damage attributed to the construction industry.

The focus of this section is to provide a comprehensive overview of current developments in the construction of building envelopes, with an emphasis on the use of bioproducts as the principal materials. The shift towards renewable materials not only signifies a sustainable pathway but also encourages innovation in the areas of facade design and construction methodology.

Understanding the choice of materials and the technological methodologies applied in the design and construction of the bio-based building envelope holds critical significance for this case study. Such an understanding illuminates the potential benefits and limitations associated with current bio-based façade systems, thereby aiding in the potential optimization of the proposed bio-based façade concept.

BioBuild – Arup & GXN Innovation.

The BioBuild project funded by the European Commission’s Seventh Framework Programme, is a project designed by Arup and GXN Innovation, where the goal is to use biocomposite materials to reduce the embodied energy in building façade, supporting structure, and internal partition systems by at least 50 % over current materials with no extra costs. The technology they use relies on biocomposites and biobased resins with the aim to replace the reliance on aluminium, steel, and concrete.

Technology:

Biocomposite is a term used for a fibre-reinforced polymer where either the reinforcement or matrix or both are made from organic sources, such as flax, jute, hemp, in a polymer matrix derived from agricultural wastes, vegetable oils or corn starches [BioBuid 2015] Biobased resins were introduced to provide resistance to moisture absorption and other biotic agents that were affecting the durability of the biocomposite. The Polyfurfuryl Alcohol Resin (PFA) is produced from sugar cane bagasse. Both the biocomposites and the bioresin have a very low embodied energy in their production compared to their counterparts such as other epoxy resins and standard construction materials. [BioBuild 2015]

Product:

- External Cladding Kit

It is a system with no load-bearing function and its application is intended for vertical or near-vertical building envelopes to protect the wall behind it from weather exposure. The cladding system is made from flax-PFA panels.

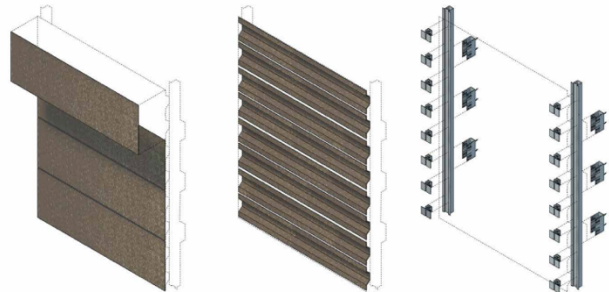

Figure 5.3: External Cladding Kit (ECK) created by BioBuild. Source: BioBuild

- External Wall Panel

The façade panel is a self-supporting wall element with internal and external architectural finishes. The panel is composed of a wood frame and the outer skin is made of biopolyester resin reinforced with flax fabric. The cavity within the frame and the skin is filled with insulation, which makes the panel achieve a thermal transmittance of $\sim 0.8 \text{ W/m}^2\text{K}$. A key feature of the system is the modularity and circularity features since it is a prefabricated panel, which components can be easily detached, and either be recycled or reused and the end of the life cycle. [Arup 2015]

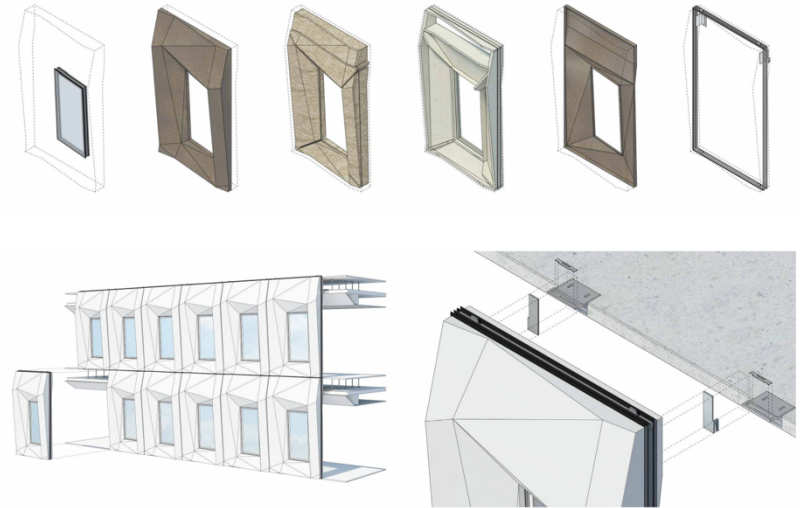

Figure 5.4: External Wall Panel created by BioBuild. Source: BioBuild

Bio-based Façade LINQ – Team virTUE, University of Technology Eindhoven, Equipment prototype centre (EPC Tue), Stam + de Koning

LINQ is a small apartment complex, where the roof and south façade are tilted 15 degrees to provide solar gain efficiency for the roofed PV panels and to create a shadowed south façade in the summer months. The building complex is designed for hot and dry weather like the city of Dubai. The façade is composed of double-glazed windows, high insulated walls (bio-foam), and pale reflective grey colour cladding. The building envelope has different features depending on the façade orientation. The South and West walls have ventilated facades, and the North wall has a green façade.

Technology:

The biocomposite material Nabasco 8010, created by NPSP, forms the basis for the façade tiles. The latter is composed of grass, recycled toilet paper, reclaimed textiles, waste cane, flax, calcium carbonate and biobased resin. [Bekkering, 2021] The calcium carbonate is a residual from the softening process of drinking water and the bioresin is a by-product of biodiesel production.

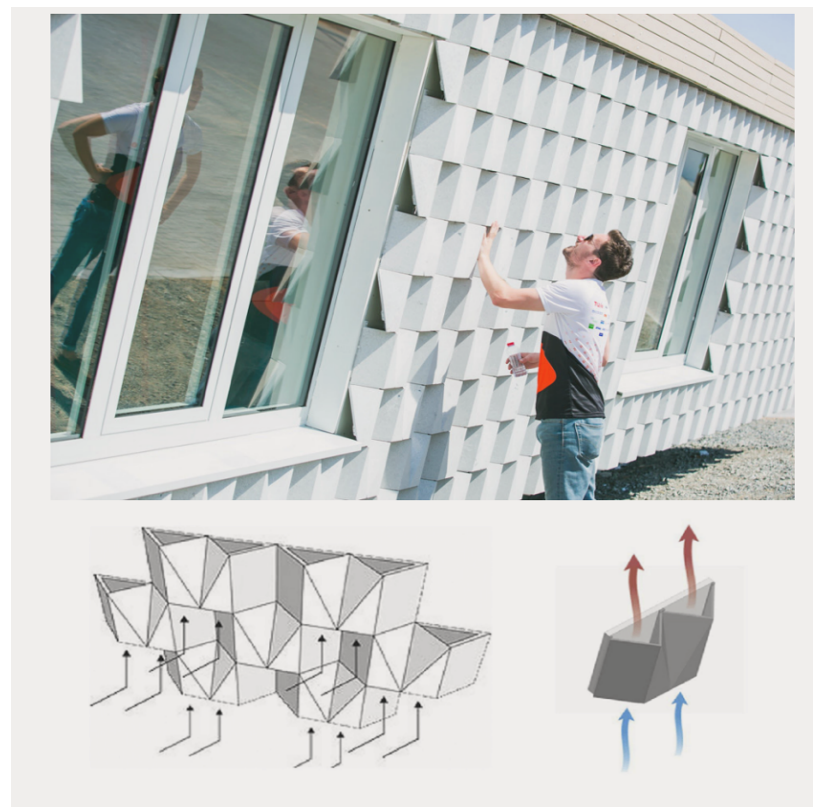

Figure 5.5: Bio-based Façade LINQ. Source: Bekkering, 2021

Product:

- Bio-based composite tile: Shape

The building envelope is designed for easy assembly and disassembly. It is composed of symmetrical lightweight tiles, whose shape allows air to flow behind them. The tiles are 3D printed and have been tested for fire safety according to EN 13501-1, thus achieving class B-s1, d0. It can be then used on a large scale in the construction industry [Bekkering 2021].

Upon the review of the case studies, it becomes evident that the successful implementation of bio-based façades transcends the focus of only material technology and processes; it also encompasses the methodology employed in the design and construction of the façade itself. Introducing sustainable practices like modularity and circularity in façade design, especially when combined with the use of bio-based materials, is crucial to creating systems that significantly mitigate the escalating carbon emissions and embodied energy currently attributable to the construction sector.

Sustainable strategies integrated at multiple stages, beginning from material selection to design methodologies and extending to end-of-life scenarios are instrumental in creating building envelopes that exert minimal environmental impact. By integrating these sustainability measures, it becomes feasible to apply façade design and construction as a multi-faceted approach that not only meets aesthetic and functional criteria but also aligns with environmental objectives.

5.3. Relevance of Timber in Façade Design

The incorporation of timber as a biobased product in façade design and construction offers advantages beyond only sustainability. The vast variety of timber products already existent in the market, ranging in different functionalities make timber suitable from a structural to an aesthetical perspective.

To harness the full potential of timber in construction, it is important to understand its unique properties from the beginning of a project's design phase. This includes understanding its interaction with various building services systems. Furthermore, a comprehensive assessment of timber needs an understanding of its fire resistance, acoustic and vibration characteristics, as well as its thermal performance. Recognizing these factors is pivotal in appreciating timber's overall contribution to a building's envelope and energy efficiency.

For this case study, the benefits, and potential limitations of timber in façade systems are the areas of focus of the analysis.

Advantages

- One of the timber's advantages is its potential to help reduce cost and construction in the commercial office sector by prefabrication. Products such as glue-laminated timber framing are optimal for modular prefabrication since combined with timber slabs can create dry lightweight prefabricated buildings that can be rapidly erected. [Arup 2011]
- Timber when used structurally, is a lightweight material compared to concrete. Softwood frames used in multistorey timber construction have around 20 % of the concrete density.
- Another important aspect of designing with timber is the reduction of costs related to finishes. The aesthetical value of timber is higher than other construction materials. Therefore, if required, timber can be left visually exposed, reducing the cost and time of installing finishes, while adding to the visual appeal.
- The thermal performance of timber is more efficient than that of aluminium, therefore contributing to the energy efficiency of the building. Timber acts as a carbon sink since it stores the carbon, captured during photosynthesis throughout the lifespan of the product.

Limitations

- Timber is a complex and variable material. Therefore, durability can be a concern depending on the environment, species selection, weather exposure, preservation treatments, and biotic decay.
- Fire safety is another concern that needs analysis. Timber is a combustible material thus understanding the fire performance of the chosen timber product is imperative.
- Vibrations under the action of lateral wind loads can be a risk for timber buildings, especially tall buildings, due to their relatively lower stiffness compared to other construction materials such as concrete.
- The stored carbon of the material gets released into the environment at the end of life. Therefore, CO₂ management needs to be addressed.

Action items to address limitations

- Knowing the material and accounting for its mechanical and physical properties from the start of the design stage is crucial to improving the performance of the material.
- Introducing disassembly, adaptation, and reuse is the ideal disposal option at end-of-life for timber products to further diminish the release of the stored carbon to the environment. These circular approaches become more attractive with the increased reliance on glulam beams and columns, and large cross-laminated timber (CLT) floor and wall panels, which already account for sustainable end-of-life scenarios [Arup 2019]
- To account for the required stiffness in timber buildings, design optimizations need to be assessed. The introduction of localized steel or the addition of a bracing system are options been considered.
- Building physics analysis is important when using timber façade systems to understand the material behaviour and avoid condensation risks.

The introduction of timber alone will not solve the many challenges the construction industry is facing due to the anthropogenic damage caused by its current practices. However, it could form a vital approach to how design and construction need to be addressed to support a more resilient built environment.

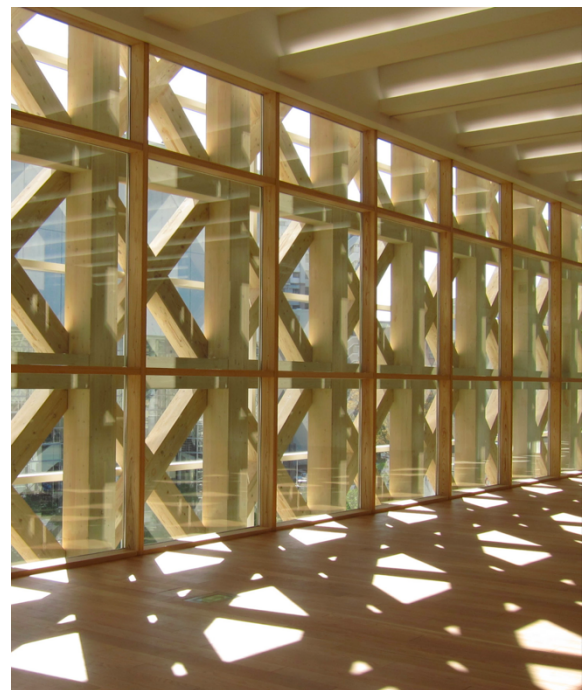

Figure 5.6: The Odgen Centre for Fundamental Physics, University of Durham, UK (left) and the Oita Prefectural Art Museum, Japan (right). Source: Arup 2011

5.4. Hybrid Curtain Wall Systems

To further understand the current methodologies used in the market that introduce timber in the façade design and construction, hybrid curtain wall systems are further analysed.

Hybrid façade systems are developed in an effort to diminish CO₂ emissions and incorporate sustainability in the construction industry, companies such as RAICO, STABALUX, Batimet, and GUTMANN started developing façade systems where structural timber is combined with aluminium profiles.

Most of these developed hybrid facades are stick-built which are simple and efficient design concepts but are not well suited for this case study due to its limitations regarding the assembly process of the system. However, RAICO has developed a unitised hybrid system as seen in Figure 5.7, where the aluminium profile is used to protect the timber and connect the glazing pane to the timber framing.

Aluminium is used as a standard approach in the hybrid system only at a functional level due to its malleability to accommodate complex extruded profiles, safe weather exposure, weather protection, and load-bearing capabilities. Therefore, introducing localized aluminium where needed reduces reliance on aluminium compared to standard aluminium element facades [RAICO].

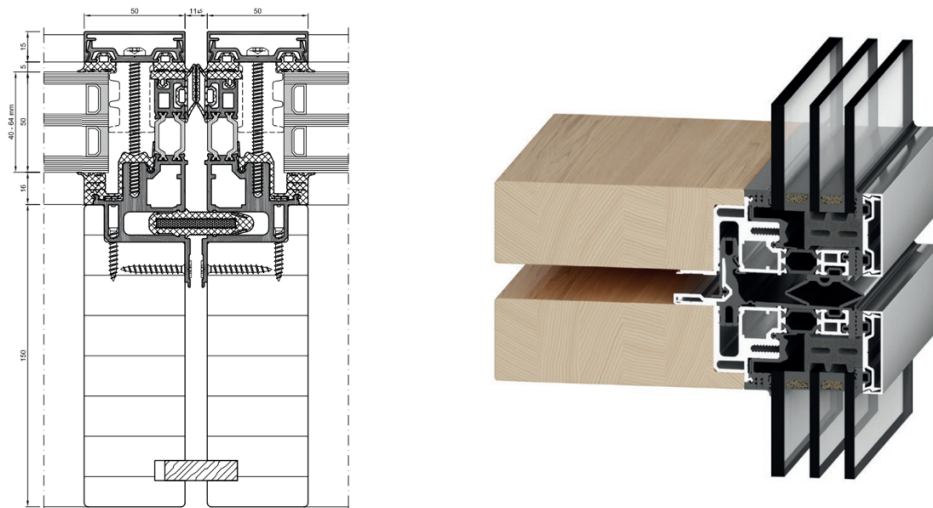

Figure 5.7: RAICO Element + H-I – Hybrid Unitised Façade System, Source: RAICO

However, aluminium has very high thermal conductivity and does therefore require additional materials to increase its thermal performance such as thermal breaks, which are low-conductivity materials such as PVC, neoprene rubber, polyurethane, and polyester-reinforced nylon. [Whole Building Design Guide 2016]. All of these are high-embodied carbon materials that contribute to the overall global warming emissions and the soaring landfill waste volume.

The need for more materials to increment the performance of aluminium also affects the adaptability and disassembly parameters relevant to this research. According to [Crowther 2020] it is important to minimize the number of different types of façade materials to simplify the assembly and disassembly process of the façade system making it less complex and more efficient. Also, the materials within the façade system have different lifespans, and, with fewer types of materials, it becomes easier to identify, separate, and recover them for potential recycling and reuse, increasing the overall recovery rate of the elements, which reduces the reliance for virgin materials, thus supports circularity.

After the review of the literature research on façade typologies, the latest applications of biobased materials in façade design, the merits, and challenges of timber within the building envelope, and the current timber façade systems available in the market, a clearer understanding emerges. This research reveals the advantages and constraints, addresses essential functionalities, and identifies areas that need improvement to efficiently develop optimal bio-based unitised façade systems. As a result, the analysis of the selected case studies and the assessment of the existing façade systems in the industry form a foundational step. This then sets the stage for the creation of a preliminary system design, an elemental part of this case study, which will be detailed in the subsequent section.

5.5. Phase I - Preliminary Façade Design Concept Formulation

5.5.1. Design Strategy

Developing the preliminary design concept is a fundamental phase of this case study since it aims to validate the feasibility of introducing bio-based unitised façade systems.

As the first stage of the design concept, the main goals and boundary conditions are specified to lay a foundation for the design methodology.

The strategy of this preliminary design concept is creating a façade system made of a timber frame and a spandrel composed of bio-based materials. The product is located in the Netherlands and is subject to European standards. The façade system is designed for a low-rise building for commercial or residential use, and the panel dimensions for a singular unit are set to 3, 6 X 1,5 m, which is suitable for a standard structural grid.

The preliminary design concept aims to have the following features:

- **Façade Components: Bio-based Materials**

Given the characteristics of the façade components, the design prioritizes not only structural robustness but also the preservation of materials. Emphasis is placed on safeguarding the materials from direct climatic exposure, a crucial measure to prevent detrimental effects like biological decay and mould growth. Simultaneously, the design promotes ventilation, ensuring that the materials have the necessary airflow to remain dry, further enhancing their lifespan.

Another critical consideration, due to the organic composition of the materials, is fire performance. Although the selected materials exhibit competitive fire resistance compared to other biobased counterparts, the inherent risk associated with organic materials mandates a thorough fire risk assessment. Therefore, compartmentalization, properly sealing the spandrel layers, and adding fire stoppers in the connections between the façade unit and the floor slab are implemented techniques to prevent fire propagation.

- **Unitised Curtain Wall Systems – Modularity:**

Unitised Curtain Wall Systems are implemented in the design proposal because the construction method enables prefabrication of the façade panels and faster installation on-site, where the façade units are connected to preinstalled anchors on the building structure. Pre-fabrication of the façade panels not only offers improved quality control of the façade system but also offers a high degree of flexibility and design freedom due to customised shapes and dimensions.

The advantages of the system include that the façade panels can be installed without scaffolds since the panels can be positioned from the interior of the building. Therefore, allowing for a safer installation process compared to traditional façade construction methods. There is also a risk reduction for all the stakeholders due to improvement through quality control and a faster construction period. [Gasparri 2019]. This construction method also facilitates the prefabrication of timber technologies in the façade system since the material's exposure to adverse weather conditions gets reduced. Another important aspect of the suitability of the system to the design proposal is enabling modular construction, which makes the façade system

easily detachable and flexible for reconfiguration and maintenance. To allow modularity in the design concept the following strategies have been implemented:

- A rain-screen cladding is implemented on the spandrel to allow breathability of the materials and also enable easy reconfiguration of the cladding, thus upgrading the aesthetics of the façade system without upgrading the overall façade panel.
- Dry mechanical connections have been implemented such as screws, anchors, and toggles instead of chemical ones for easy assembly and disassembly purposes and to not damage the materials.
- The design follows an open design, where the façade components can be easily accessed and upgraded or maintained.
- The number and type of façade components have remained minimal to make the disassembly process more manageable.
- Secondary finishes in the bio-based materials have been avoided to not interfere with the materials' EoL recyclability and reusability potential. [Crowther 2002]

• **Circularity:**

To integrate circularity, the design concept is intended to facilitate the reuse, recycling, updates, and reconfiguration of the different façade components. Therefore, modularity is the first step to enabling circularity. By applying modularity, the design for adaptability and disassembly becomes easier to pursue, thus potentially enhancing the life cycle iterations of the materials used. The main emphasis is therefore on creating a façade system that enables “technical re-loops” of materials and components, where the materials chosen have a low negative impact on the environment while having an optimal functional performance. Thus, extending the life cycle of the system and the components and allowing for reuse, recycling, and upcycle at the end-of-life of the materials.

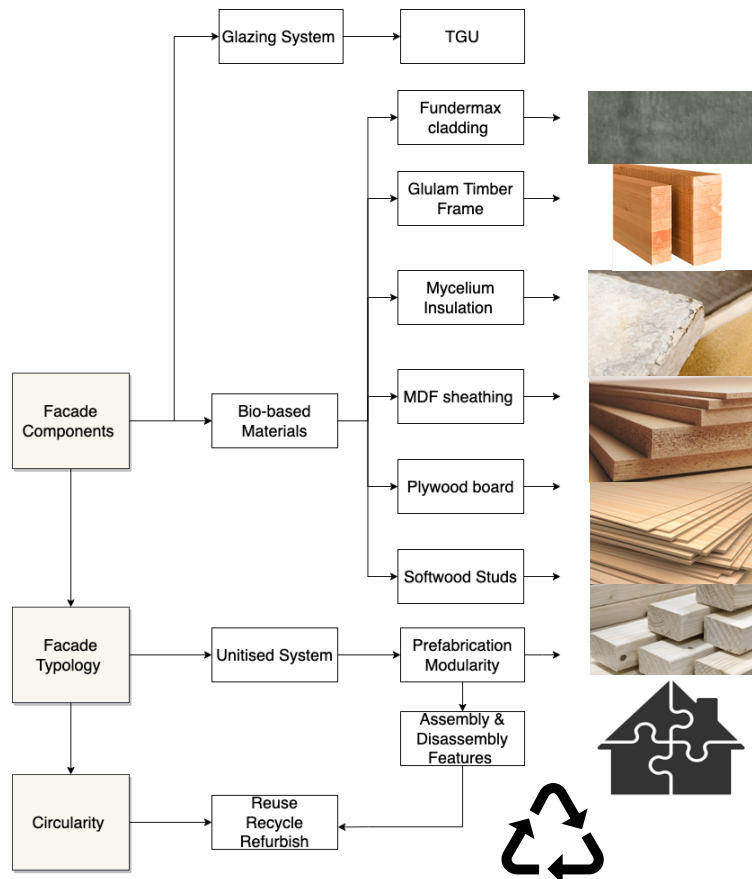

Figure 5.8: Preliminary design concept layout. Source: by author

At this stage, the initial design phase starts with a focus on minimizing the application of high-embodied carbon materials. The target of this design proposal is to create a concept that is fully unitised with no aluminium content that can efficiently accommodate an opaque panel composed of bio-based materials and a glazing system while achieving optimal energy performance and an aesthetically pleasing design.

However, having removed the aluminium profiles in the façade system adds some constraints to be considered:

- The glazing system doesn't have any support or attachment mechanism to get connected to the timber frame. A connection system is needed.
- The timber is exposed to moisture ingress. Aluminium serves as a weather-tightness mechanism that together with the gaskets prevents any water and moisture infiltration. Thus, finding solutions to protect the timber is important. Such solutions involve the design and placement of the materials to shield against weather exposure and localize the most sensitive areas of the timber for moisture control and add localized protection.

5.5.2. Glazing System

A dry glazing system over structural glazing is chosen for the preliminary design concept because of the accessibility of the system to detach the glazing panes from the frame. In a dry connection, the glass system is placed into the frame with compression gaskets. To secure the glass to the frame, a toggle connection is used to clamp the internal glass pane to the frame. The toggle connection is further explained in the following subsection.

A triple glazing system is used to improve the thermal performance, and sound insulation, and increase security. The TGU is composed of 16 mm argon-filled cavities to reduce the heat loss through the panes. The cavities are set to 16 mm to assure an optimal thermal performance. The outer glass pane is 2 mm thicker than the inner and central pane to prevent the bowing effect. The latter takes place due to changes in the exterior temperature that result in glass expansion and inner cavity suction. Therefore, placing thicker glass on the outside of the system can help mitigate the distortion of the glass pane and potential breakage. Another reason to place thicker glass panes on the exterior and thinner panes on the interior is to improve sound insulation because different thicknesses alter the sound wavelength as it passes through the glazing panes, thus reducing sound transmittance.

As seen in the following figure, a 6 mm low emissivity glass is used in the interior to minimize the amount of infrared and ultraviolet light that comes through the glass without reducing the amount of light that goes into the building. When placed on the interior, it reflects the heat thus preventing heat losses in the building. In the centre of the system, a 6 mm clear toughened glass is used to reduce potential mechanical or thermal rupture and to ensure greater uniform load strength. Lastly, the outer pane is an 8 mm laminated coated glass to reduce the heat gain through the glass, thus the coating aids in allowing high light transmission and low g-values and decreasing glare. [Saint Gobain Glass]

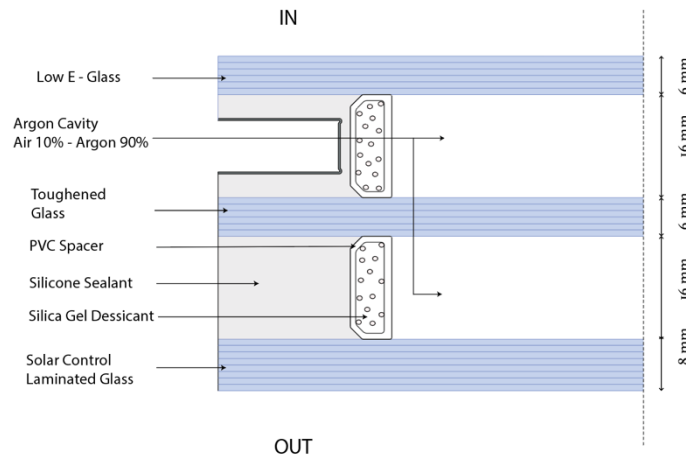

Figure 5.9: Triple glazing system used in proposed bio-based façade system, Source: by author.

5.5.3. Connection Systems

Following the design for assembly and disassembly parameters chemical connections such as adhesives are avoided to prevent further damage to the façade components at the end of their lifespan and increase the reusability and recyclability of the elements. Therefore, the focus centres on mechanical connections such as clamping systems which allow the detachability of the façade components for a technical upgrade such as maintenance and reconfiguration of obsolete components.

Connection systems affect the aesthetical finishing of the façade concept since they can be visible or minimal. The goal is to develop a concept where the appearance of the façade system stays relevant throughout the years without quickly becoming uninteresting and outdated. Thus, opting for a clamping connection becomes the best solution since it provides a sleek and minimalist appearance, optimizes transparency, and allows for a greater amount of natural lighting.

There are different clamping mechanisms used in the market such as tension rod systems, point fixing systems, channel systems, etc. The one applied in this concept is the toggle system that is going to be used as a point-supported system. The toggle is inserted through the notches in the glass panels and then connected to the curtain wall frame by using brackets or continuous pressure plates, forming a secure mechanical connection. The toggle clamping mechanism is usually used in stick curtain wall facades since it allows for easy on-site assembly. In stick-built systems, the toggle connects the two consecutive glazing systems and attaches them to the frame as seen in the figure below. It also adds a silicone sealant between the glazing systems for weather protection.

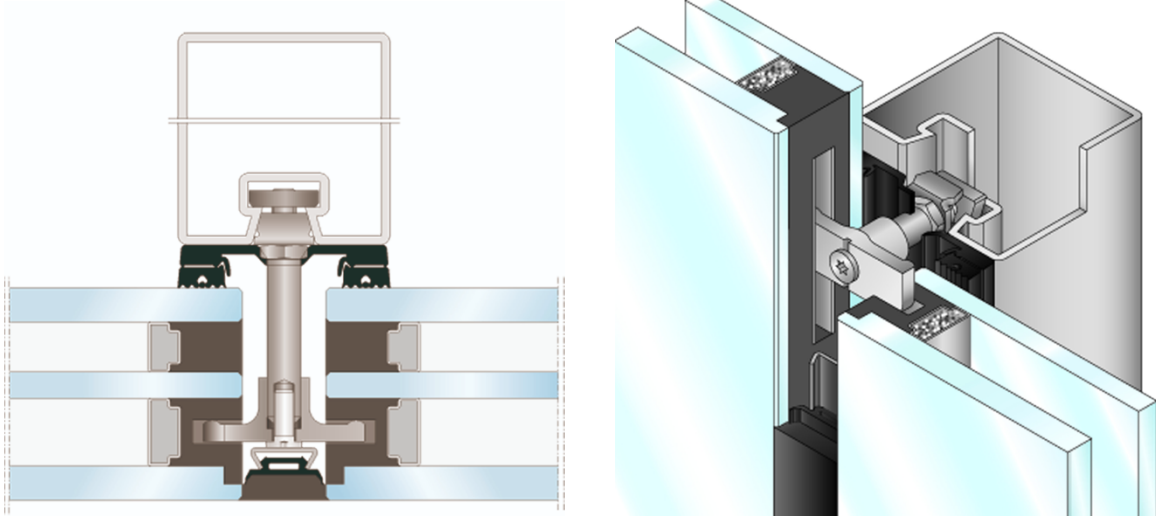

Figure 5.10: Toggle clamping mechanism is shown in a stick-built curtain wall system. Source: Sage Glass

Following that methodology, the toggle system is implemented in the design concept. The toggle clamp will have an L-shaped instead of a T-shape since it will not attach consecutive facade panels but will connect them independently to allow freedom of assembly and disassembly. The toggle clamp will be fastened to a stainless-steel receiver which will be welded to a stainless-steel plate to finally get connected to the timber frame by stainless steel screws. The silicone sealant attached in the gap between glazing systems will also not be added in this proposal since it adds difficulty for detaching the facade panels, thus moisture protection mechanisms to protect the toggle connection from water ingress to the system are important aspects to consider.

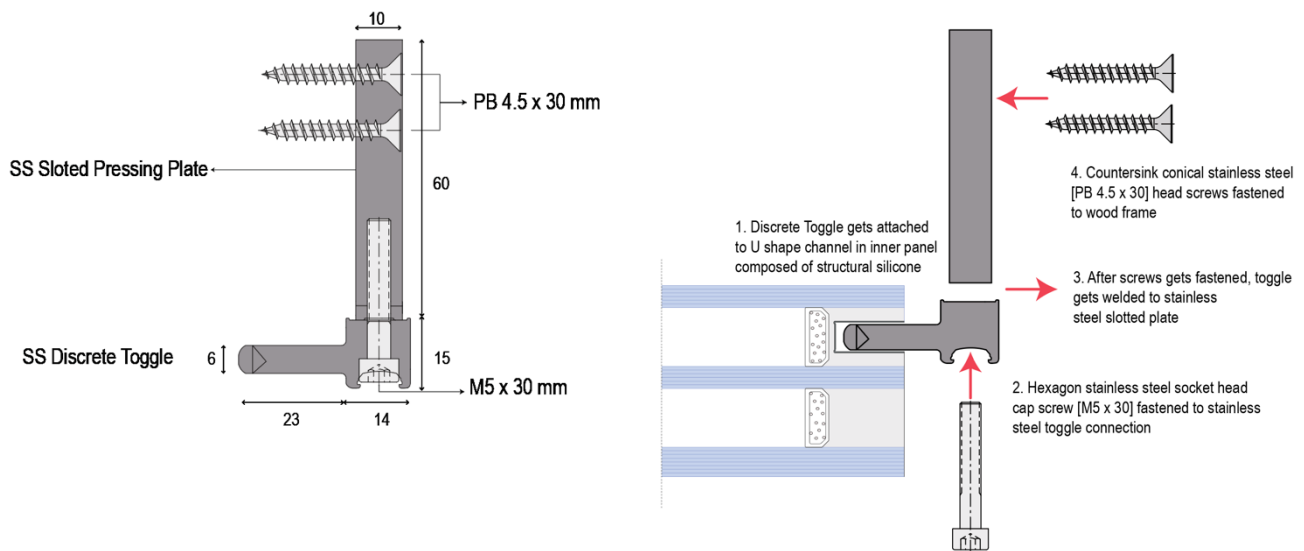

Figure 5.11: Discrete Toggle Configuration for Preliminary Bio-based Design Concept. Source: by author

It is important to note that the toggle connection is discrete, thus 6 toggles will be connected horizontally and vertically along the transoms and mullions to properly attach the glazing system to the frame. The dimensions of the stainless-steel plate and toggle clamp have been structurally checked based on the dimensions of the building and expected wind loads of the location the pilot project is based.

- **Screw Connection**

Special attention needs to be given to the connection of the stainless-steel slotted plate to the timber frame. The length of the screws was chosen to allow enough space from the edge end of the timber to avoid splitting. In addressing the potential issues associated with thermal elongation—resulting from the marked difference in thermal conductivity between stainless steel and timber—countersunk screws are employed. These screws are not only favoured for their ability to mitigate thermal elongation but also due to their superior withdrawal resistance. The determined screw length is strategic, allowing for adequate distance from the timber's edge end to prevent undesirable splitting.

Wood-based materials exhibit diminished strength when tension is applied perpendicular to the grain. Similarly, adhesives tend to have reduced strength perpendicular to the glue line. With these considerations in mind, screw connections are aligned parallel to both the glue line and grain direction of the timber frame. This alignment minimizes the risks of splitting and potential degradation of the timber frame's strength. [IstructE, TRADA 2007] The incorporation of a stainless-steel slotted plate serves a dual purpose: facilitating moisture-related movements of the timber and acting as an anchor for the screws, which are positioned in alignment with the plate's edge. This alignment further reduces thermal elongation and diminishes potential moisture collection. As an added protective measure against moisture, a continuous gasket is meticulously positioned beneath the stainless-steel slotted plate, ensuring the timber's protection. The specifics of the continuous gasket and other features of the preliminary design concept are explained in detail in the following subsections.

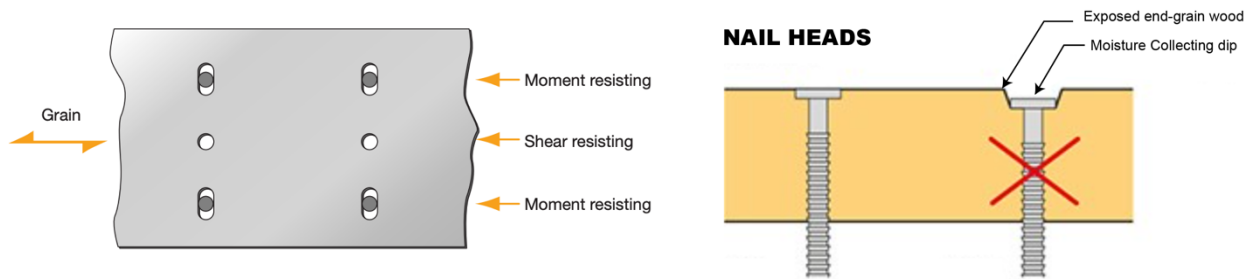

Figure 5.12: Slotted stainless-steel plate (left) & stainless-steel countersunk connection. Source: IstructE/TRADA,2007

5.5.4. Material Implementation Stainless – Steel

Stainless steel is the proposed material to use for the toggle system and the material of choice to locally protect the timber frame from weather exposure. Due to the goal of removing aluminium from the façade system, the current design proposal lacks a protective layer on the outer section of the timber frame.

The modular nature of the façade system and the fact that the glazing system follows a dry connection, there is no silicone sealant applied between the glazing systems to act as a weather barrier, thus the timber

frame can be damaged due to moisture load exposure. Therefore, a stainless-steel sheet is proposed to protect the sensitive areas of the timber frame.

The material was chosen due to its ability to resist corrosion and rust, which are relevant to the design concept since the material will protect the timber from any water and moisture infiltration. Other qualities of the material that make it a more suitable option than aluminium are its strength, fatigue resistance, heat resistance, and thermal conductivity. The optimal structural properties of steel make it a good candidate to withstand the loads from the glazing system and transfer them to the timber frame. It can also tolerate higher temperatures than aluminium without losing its strength or shape, making it a good option for outdoor applications and extreme weather conditions.

Thermal Conductivity is another important parameter that aluminium is poorer in. The material has an average of 235 W/m-K [MakeItFrom] while stainless steel has an average of 45 W/m-K [MakeitFrom], depending on the type of alloy.

For the design concept, optimal thermal conductivity is critical to improving the thermal performance of the system and diminishing the risk of thermal bridging. By choosing a material with lower thermal conductivity, the risk of condensation diminishes since there is a less drastic change in the thermal conductivity of timber [0.18 W/m-K] and stainless steel than timber and aluminium.

Other important parameters to mention are regarding the sustainability of the production of the materials. Even though the results vary depending on the specific type of materials. Stainless steel has an overall lower embodied carbon, energy, and water compared to aluminium [MakeItFrom]. There are also, disadvantages to the application of stainless steel due to the weight of the material and the machinability limitations which add a constraint on the shapes and extrusions that may be needed. Such limitations have been considered in the design concept, which also further incentivized the use of a minimal thickness and localized application of the material in the proposed façade system.

5.5.5. Preliminary Design Cross-Sections

Based on the modularity feature of the system, the design seeks to engineer independent façade components for easy disassembly. The removal of the use of aluminium profiles which traditionally are employed as a weathertight mechanism, amplifies the concern surrounding the protection of the timber frame from water ingress. Therefore, design methodologies that introduce moisture control strategies are taken into consideration in the design concept.

One of the measures taken is to add a 1 mm stainless steel protective sheet around the outer section of the mullion up to the first interlocking pocket to prevent any moisture contact with the frame. On top of the stainless-steel sheet, a continuous EPDM gasket is placed to close up the mullions gap and serve as an intermediary between the stainless-steel sheet, the stainless-steel slotted plate, and the glazing unit. The first interlocking gasket serves as a primary line of defence protecting the inner part of the mullion from weather exposure while the rain screen gasket serves as a flushing gasket whose functionality is to allow air to go in and add breathability to the timber frame.

Another important aspect of working with bioproducts is the importance of the breathability of the material, allowing the timber frame and bio-based spandrel components to breathe prevents any moisture residue from progressing as biological decay. However, achieving breathability while trying to protect the frame from water ingress is a challenging mechanism. At this stage, the incorporation of a rain screen gasket in the outer section, the stainless-steel sheet covering up to the first line of defence, and the interlocking gasket as a primary line of defence come down as the first strategy towards the development of the design concept. The preliminary design concept cross-sections showing the mentioned features are presented below.

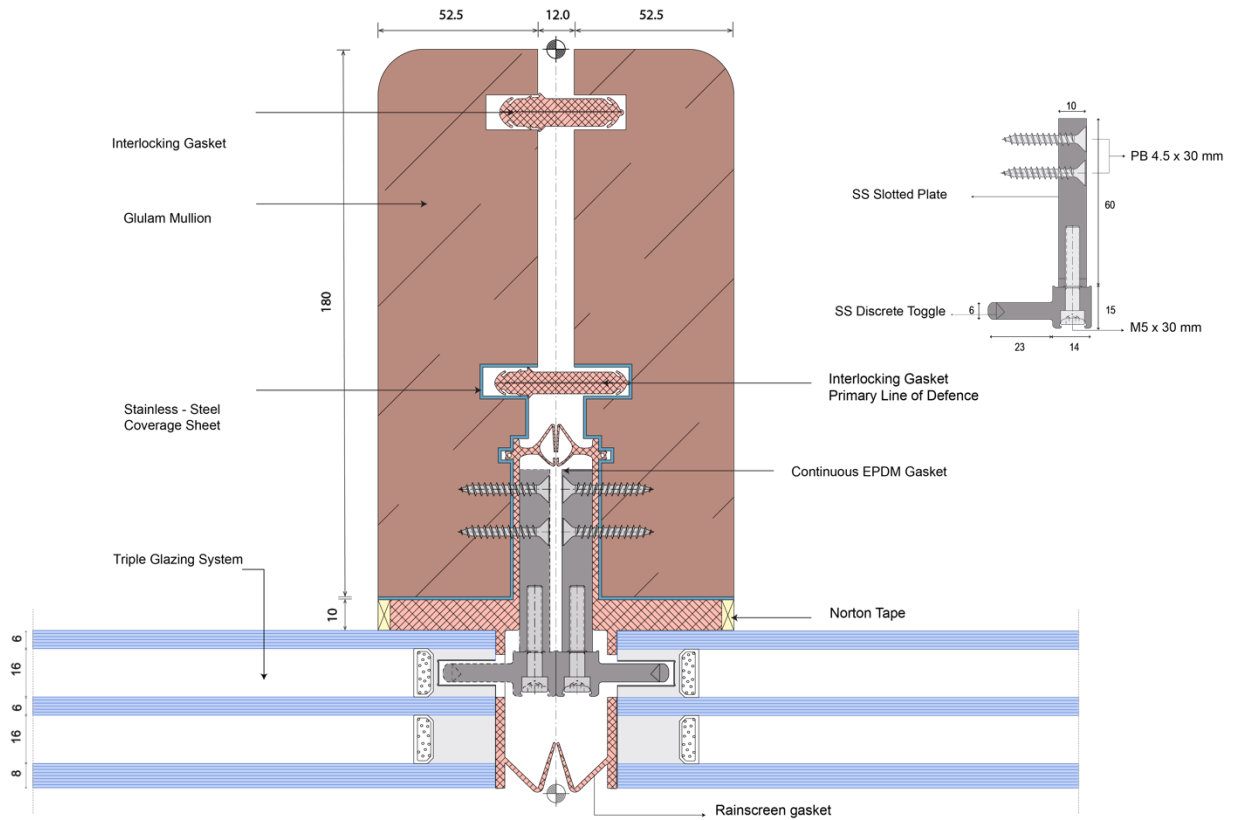

Figure 5.13: Preliminary Design Concept: Vision Mullion Cross-Section. Source: by author

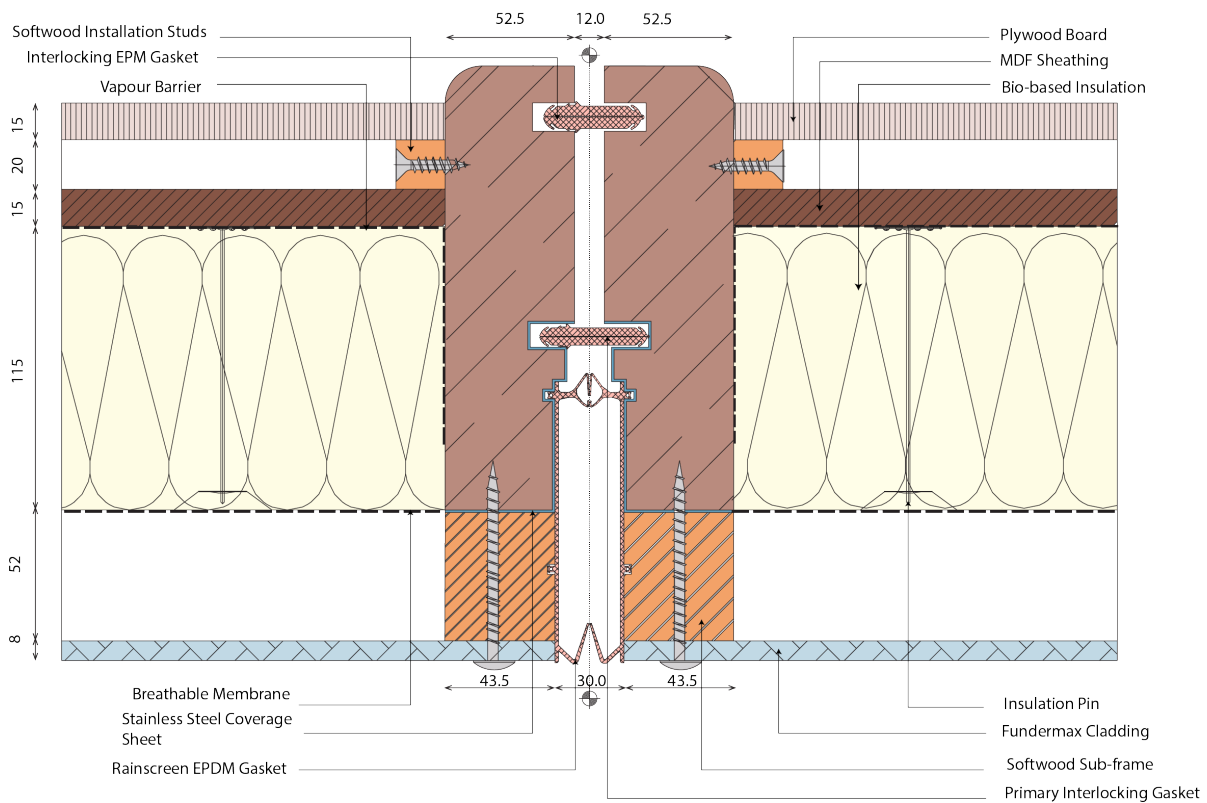

Figure 5.14: Preliminary Design Concept: Spandrel Mullion Cross-Section. Source: by author

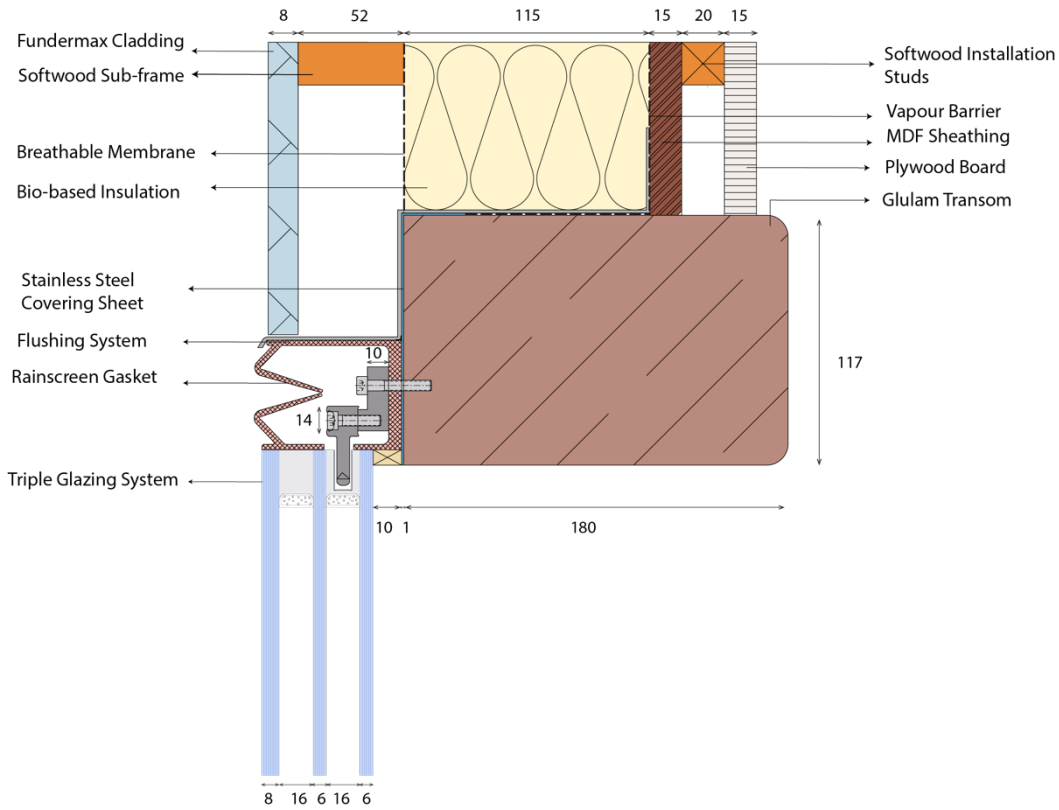

Figure 5.15: Preliminary Design Concept: Intermediary Transom Cross-Section. Source: by author

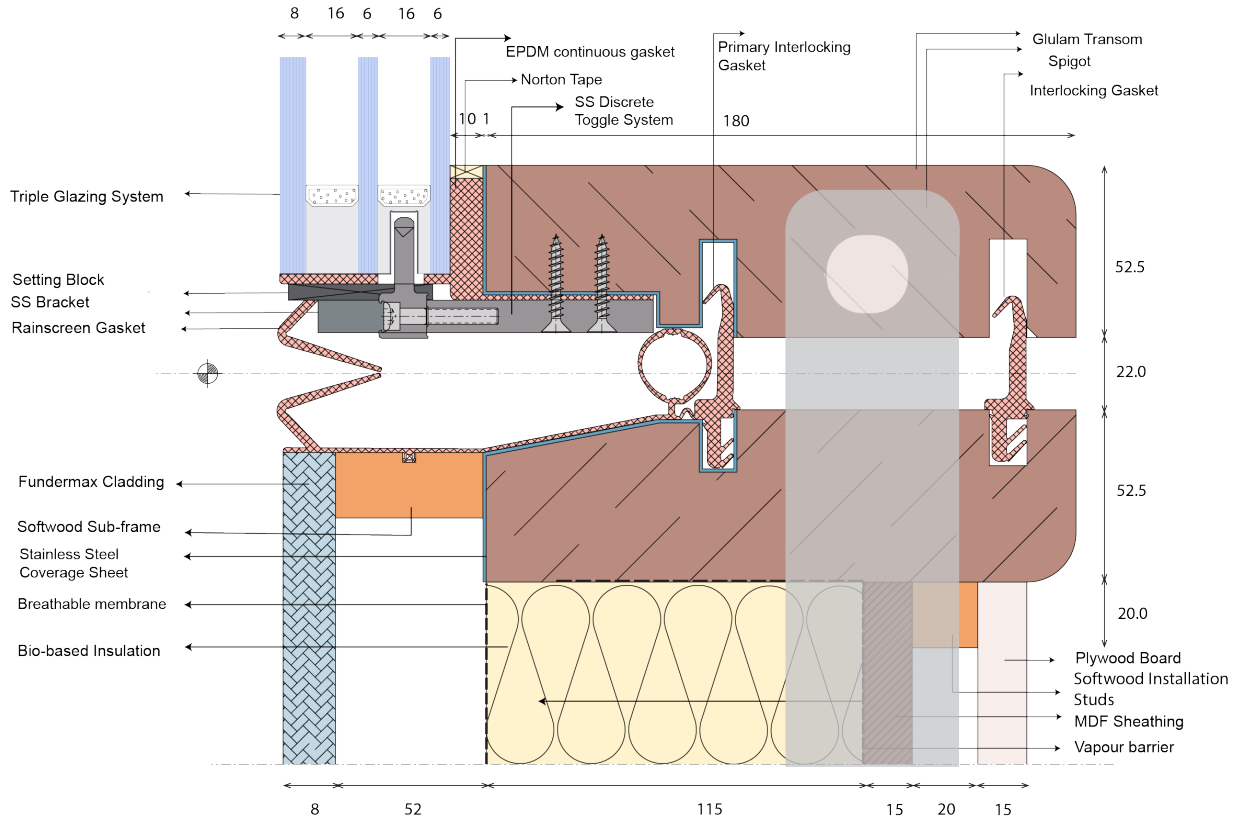

Figure 5.16: Preliminary Design Concept: Consecutive Transom Cross-Section. Source: by author

5.5.6. Moisture Control

Moisture ingress is an important constraint that needs to be addressed in the design concept. At this preliminary stage, the implemented moisture control features rely on the gasket system and the stainless-steel covering sheet.

The continuous EPDM gasket system is placed on the outer section of the frame, between the stainless-steel sheet, stainless steel plate, and glazing system to avoid direct contact between them. Also, it serves as a protection from water and moisture ingress mostly when the toggle connection gets fastened to the frame. As observed in the following figure, the interlocking gasket acts as a primary line of defence, while the continuous EPDM gasket serves as a secondary line of defence on the outside, and an extra water and moisture filter on the inside with the addition of a balloon gasket.

The position of the glazing system and cladding are also decided to protect the timber frame from direct weather exposure; thus, the glazing system and cladding layer are placed on top of the frame. The use of weather-resistive barriers is another mechanism which aims to control the moisture transfer through the façade components. For this design concept, a breathable barrier is placed on the outside of the spandrel section to allow ventilation, and a vapour barrier is placed on the inside, between the insulation and MDF sheathing layer to block moisture diffusion to the bio-based insulation.

Even though the role of the stainless-steel sheet is to protect the timber frame, its addition can be harmful to the material. Due to the different thermal conductivities of the timber and steel, condensation may arise in the areas in close contact with the steel, thus causing biodeterioration. Also, the stainless steel while protecting the material may prevent moisture diffusion from the material, which can also damage the timber frame by moisture retention. On the other hand, if the stainless-steel sheet gets removed to allow breathability of the material, the frame will only have the gasket system as the main protective feature, which can also be a concern if the frame is exposed to higher moisture loads.

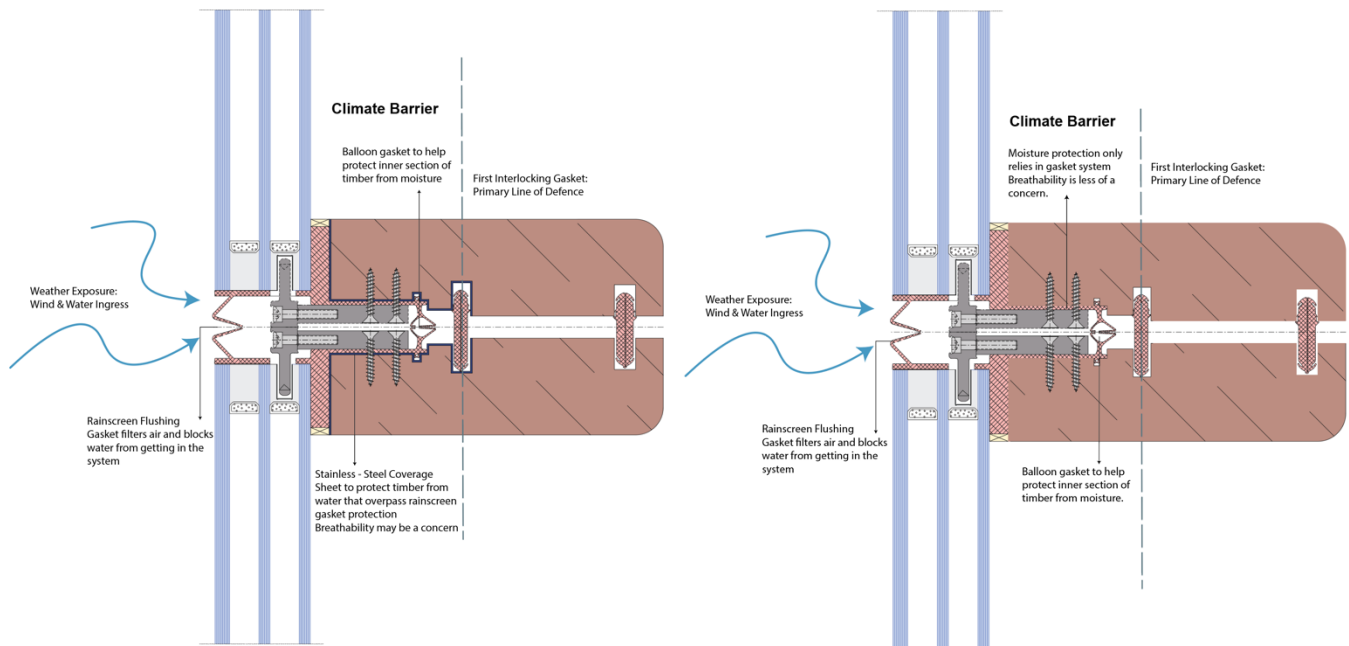

Figure 5.17: Moisture control strategies for preliminary design cross-sections with stainless steel covering sheet -Configuration A (left) & without the protective sheet – Configuration B (right). Source: by author.

Therefore, further analysis needs to be incorporated to understand the behaviour of the timber with the stainless steel as a protective layer or if the timber is adept to withstand the exposure of climatic conditions on its own.

To fully understand the feasibility of the proposed design concept and guarantee its optimal performance a thermal and hygrothermal analysis of the cross-sections is performed.

Configurations A & B, as seen in the figure, are implemented to understand the impact of the stainless-steel shell as a protective mechanism. Configuration A represents the façade system with the stainless-steel sheet while Configuration B is the system with the gaskets as the main coverage against weather exposure. All the cross-sections are designed under both configurations. The following chapter further investigates the impact of the stainless steel on the timber frame and proposes a comparative analysis to find which configuration is more suitable for the design concept.

5.6. Phase II - Design for Disassembly

An important methodology analysed in this research project and implemented in the design proposal is designed for disassembly (DfD). DfD is a sustainable design approach with a focus on designing façade systems that can be easily disassembled, deconstructed, or dismantled at the end of their lifespan. The design approach considers the entire life cycle of the façade system and components to enable the potential for reuse or recycling of the materials.

Façade systems should not only be designed for assembly but also disassembly. However, it can be challenging to include the disassembly capacity of the system in the early stages of the design phase. [Gasparri 2019] Therefore, it is important to pay attention to the connections used in the system. Also, the separability potential of façade layers needs to be assessed to understand the end-of-life scenarios of the different materials and their possible reusability.

When designing for disassembly and potential material recovery, it is important to consider the chosen materials, the finishes the materials required, the geometry of the façade itself and how the façade system is fixed to the structure. If the design for deconstruction is considered in the early design phase of the curtain wall system, components can be dismantled from the inside. Therefore, mitigating the use of scaffolding or external lifts, makes deconstruction safer and more cost-effective [Kim 2013]

Regarding the design proposal, the design for the disassembly approach has been introduced and is one of the goals of the design. The followed methodology to accomplish disassembly was introduced by a thesis project presented in 2006 based on Transformable Building Structures [Durmisevic 2006] and Design for Disassembly principles and strategies established by [Crowther 2002]

Durmisevic proposed a methodology where the configuration of the façade system is divided into three main domains: Functional, Technical, and Physical decomposition. The purpose of this division is to analyse the independence and exchangeability potential of the façade components. Thus, understanding the relationship between the performance criteria of the materials, their position in the assembly, and the created dependencies based on their functionality and location which are imperative to assess their separation potential. The following figure shows the methodology structure for design for disassembly followed in the design concept.

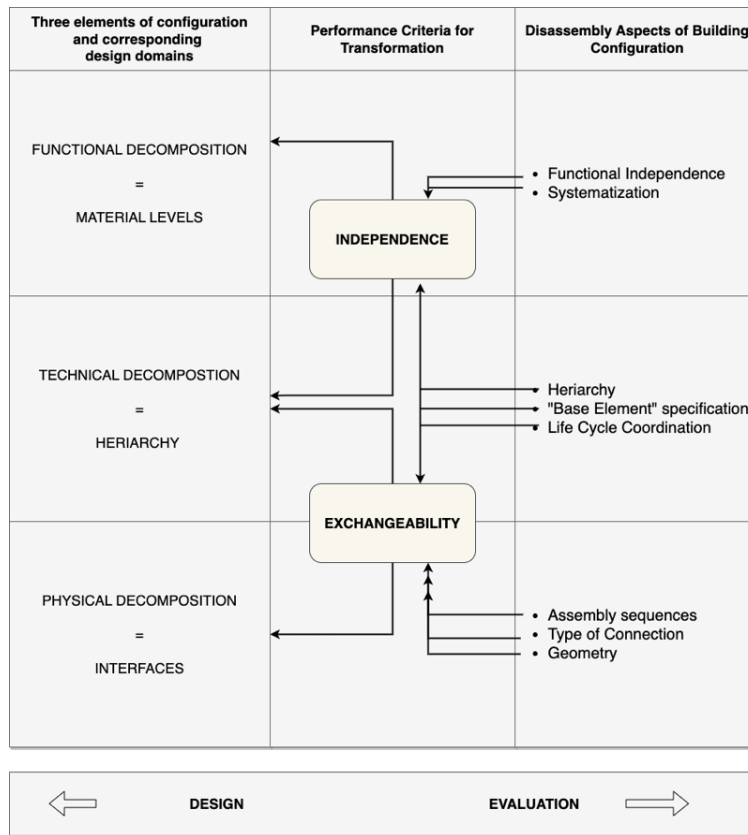

Figure 5.18: Relation between disassembly aspects and design domains. Source: Durmisevic 2006

5.6.1. Functional Decomposition

Functional decomposition serves as the initial evaluation domain for designers to create flexible façade systems. This step involves the analysis of each component’s function within the system, significantly influencing decision-making concerning disassembly. Multiple functions may be unified within a single façade component, or assigned to separate components, impacting the system's transformability.

A close examination of the materials' functionalities reveals initial insights into the system's potential for transformation. Another important factor to determine is the interrelations within the façade components, dependencies within the materials can be very common and heavily depend on the geometry of the system, interfaces, and the creation of sub-assemblies within the system.

Consequently, the materials’ level of independence is governed by the separation degree between different functions within a single configuration, coupled with the autonomy of independent functions [Durmisevic 2006].

In assessing the disassembly potential of the preliminary design concept, the vision mullion cross-section and its components are analysed based on the performance of each material and the interplay among them. In alignment with design objectives, four central functionalities emerge: finishing aesthetics, illumination,

thermal performance (notated as a weather barrier), and structural integrity. The vision mullion profile is designed to separate functionalities, promoting the accessible disassembly of components. However, some materials, such as glazing and toggle systems, serve more than one function, dealing with illumination, aesthetics, and load bearing. Despite their interdependence, the dry glazing application and point-supported toggle connection enhance the accessibility and potential decomposition of the glazing system.

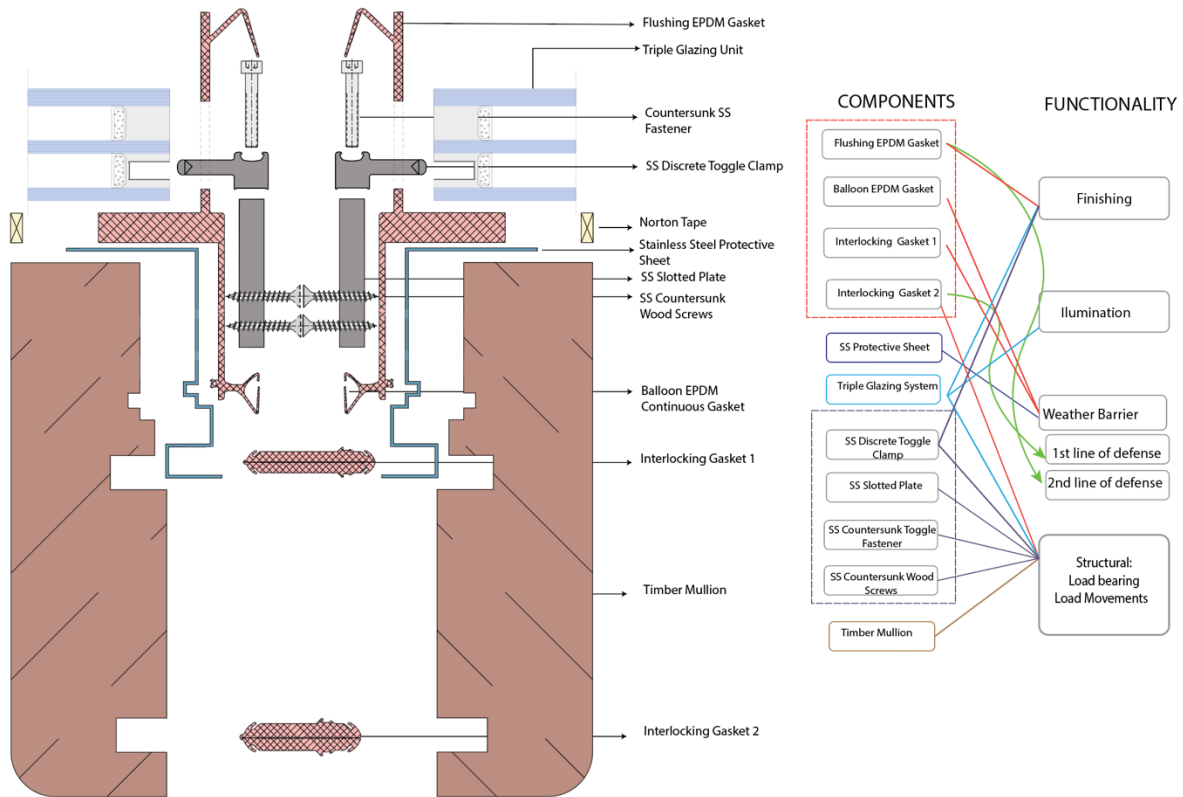

Figure 5.19: Functional Independence Diagram for Preliminary Design Concept. Source: by author

The weather barrier is achieved through a three-level independent gasket system. However, maintenance or upgrade concerns arise, particularly with the continuous gasket located between the timber frame and the glazing system and toggle connection, since it needs the glazing system removal to access the gasket.

Furthermore, systematization analysis is conducted, which explores the creation of clusters based on life cycle performance requirements and material integration levels. A cluster is treated as an independent building section throughout its production, use, and assembly/disassembly stages [Durmisevic 2006]. In the case of the vision mullion profile, a system-level cluster is identifiable, allowing for easy attachment and detachment of the façade modular panel to the building’s floor slab. Nonetheless, partial independence is observed at the cross-section level, particularly within the glazing system connection, due to its dependency on the timber frame.

5.6.2. Technical Decomposition

This domain identifies the relational patterns and hierarchy structure within product elements, materials and components that will influence future element replacement for maintenance and upgrades.

The analysis of the preliminary design concept, coupled with an assessment of the classification in the figure below, the design concept follows a table assembly hierarchy. In this assembly configuration, the building parts are kept independent from one another by only creating dependent relations to elements within an assembly. In this case study, the timber frame is the base element that dependencies are formed with. Regardless of the dry glazing connection, it depends on the timber frame to get screwed into the façade system.

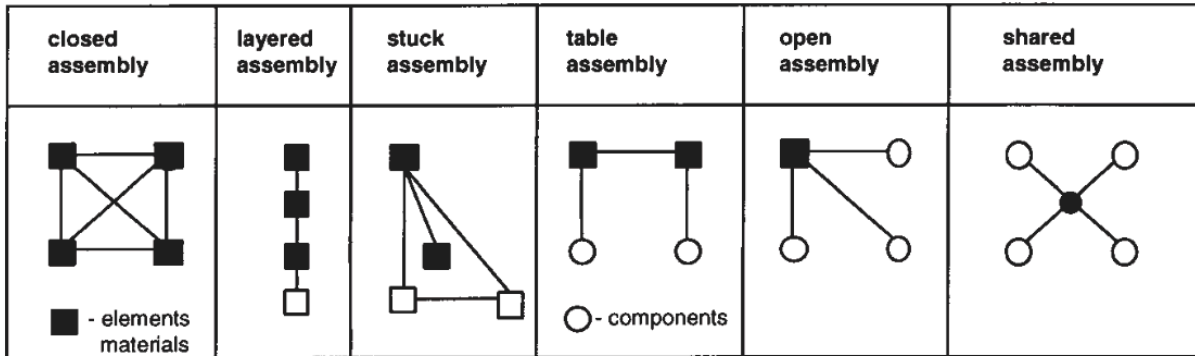

Figure 5.20: Classification of Assemblies according to the type of relational patterns. Source: Durmisevic 2006

5.6.3. Physical Decomposition

This section overviews the aspect of design concerning the connections between components that support exchangeability, thus contributing to an increased disassembly and potential transformation of structures. Following the analysis of the preliminary design concept and assessing the toggle connection for attaching the glazing system to the timber frame. The connection is assessed as an integral connection or direct connection, within this category, the discrete toggle connection aligns with the definition of overlapped connection, which is typically employed in connections between vertical external façade components. In such connections, two elements are joined with a replaceable accessory. If one element within the connection has to be removed, then the whole connection has to be dismantled. [Durmisevic 2006] Their disassembly depends on various factors including the type of material used in the connection, the sequence of assembly, the hierarchical position of the components, and their relations with other components.

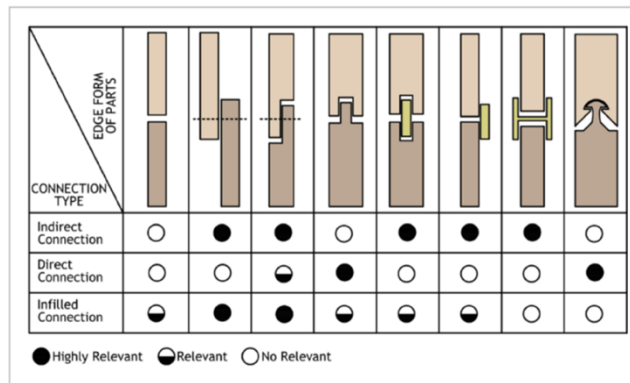

Figure 5.21: Relationships between connection types and their impact on disassembly. Source: Deniz & Doagn 2014



6. **PERFORMANCE ASSESSMENT & SYSTEM OPTIMIZATION**

The thermal and hygrothermal performance of the preliminary bio-based design concept is analysed in this section. Simulation is performed to understand the behaviour of bio-products in the Belgian & Dutch context to optimise the proposed design based on the gathered results.

6. Performance Assessment & System Optimization

6.1. Introduction

The integration of software analysis tools in evaluating building envelopes has brought notable improvements to the design review process and optimization. Such simulation software streamlines the process, offering a more efficient and well-informed design review supported by quantitative data. According to [Mukhopadhyaya et al. 2003], It bypasses the need for traditional, regional-specific methods which can present 'limited performance assessment results'.

With a growing emphasis on the use of bio-based materials in façade design and construction, a rigorous examination of the thermal performance of building envelopes is important. This assessment is vital as it measures the envelope's effectiveness in reacting to climatic exposure, subsequently influencing the energy demand necessary to ensure occupant comfort. Though bio-based materials, like timber, are praised for their minimal carbon footprint in comparison to standard construction materials, their organic nature can make them vulnerable. Variations in moisture and relative humidity, for instance, can deteriorate their mechanical properties. Such susceptibility, as noted by the [Canadian Wood Council 2004], can initiate decay processes such as mould and fungal proliferation, undermining the material's performance.

To comprehensively assess the impacts of environmental exposure on the façade system, a hygrothermal analysis is essential. This technique examines vapour diffusion and moisture transfer across the façade system's multilayer components. Such an analysis is crucial in deciphering the system's behaviour, and determining whether the façade design should be updated to safeguard the materials and enhance efficiency. Central to these evaluations is a thorough understanding and definition of the climatic conditions the bio-based façade system will encounter, given its profound influence on material durability and the overall efficacy of the façade system.

The reliance on simulation assessments will be instrumental in discerning the moisture challenges and heat conduction processes the system will face throughout its operational life. Notably, the merits of employing thermal and hygrothermal simulations are twofold: they are both cost-effective and time-efficient compared to other evaluation tools such as laboratory and field tests. This obtained data will guide design improvements, mitigating potential material deterioration and ensuring the façade system's optimal serviceability.

6.2. Steady- State Thermal Analysis

6.2.1. Therm 7.8 Simulation Set-up

The software Therm 7.8 developed by the Lawrence Berkeley National Laboratory, stands as a finite element analysis software, specifically designed to model, and analyse two-dimensional steady-state heat flow. One of its primary utilities lies in its ability to compute the Thermal Transmittance [W/m^2K] and Resistance [m^2K/W] of specific construction assemblies. For the purpose of this analysis, the boundary conditions used are presented in Table 8. These conditions are derived from the Therm 7.8 Database, a repository accredited by the National Fenestration Rating Council [NFRC]. The database aids in determining the thermal transmittance of the proposed bio-based façade system. Additionally, Table 9 delineates the boundary conditions that are assigned for evaluating the risk of condensation for the bio-based cross-sections, in compliance with the weather parameters of Amsterdam, Netherlands.

Boundary Conditions	Temperature [C]	Heat Transfer Coefficient [W/m ² K]	Emissivity [-]
NFRC 100-2010 Exterior	-18	26	0.9
Interior Wood/Vinyl Frame (Convection only)	21	2.44	0.9
Glazing – U factor Inside Film	21	1.68	0.84

Table 8: Boundary Conditions applied to proposed bio-based cross-sections for heat conduction analysis. Source: National Fenestration Rating Council [NFRC], Therm 7.8 Database.

Boundary Conditions	Temperature [C]	Heat Transfer Coefficient [W/m ² K]	Emissivity [-]
NFRC 100-2010 Exterior	-6	26	0.9
Interior Wood/Vinyl Frame (Convection only)	21	2.44	0.9
Glazing – U factor Inside Film	21	1.68	0.84

Table 9: Boundary Conditions applied to proposed bio-based cross-sections for the condensation risk assessment based on the Netherlands weather conditions. Source: Therm 7.8 Database.

6.2.2. Thermal Transmittance (U-Value) Calculation

The thermal properties of the proposed bio-based façade system, specifically its transmittance and resistance, were subjected to analysis using the Therm 7.8 software. Within the scope of this study, two distinct configurations of the façade system were examined for their thermal performance. The first, Configuration A, represents the bio-based façade system with a stainless-steel sheet, serving as a protective layer for the outer section of timber framing. In contrast, Configuration B is the standard bio-based façade system, where the protection against weather exposure relies mostly on the gasket system.

The U-value of the bio-based system was determined using the "area weighted method", according to EN ISO 12631. This calculation approach states that each distinct area of the frame, glass, and spandrel be multiplied by its specific U-value. The multiplied values of these individual products are subsequently divided by the overall area of the façade unit. This procedure ensures that by multiplying the U-value for each component's area, every section of the façade is appropriately represented. Consequently, this offers an accurate measure of the rate of heat loss through each component, taking into account the unit temperature difference between the interior and exterior, and factoring in their respective dimensions. [Anderson & Kosmina 2019]

The thermal properties of the materials are listed in Table 10, and characteristic thermal conductivities and emissivity values of each façade component are provided by the Therm 7.8 Database. Due to the discrete toggle connection, the thermal conductivity applied in the simulation software had to be calculated based on the number of toggles used in the system and the dimensions of the connection. The effective conductivity of the staggered toggle connection is shown as follows:

Effective Conductivity of Discrete Toggle Connection

- Total number of toggles = 6
- Toggle connection height = 75 mm

- Toggle O.C. spacing = 465 mm

$$K_{eff} = F_b \cdot K_b + F_n \cdot K_n$$

- $F_b = W_b/S_b = 75/465 = 0.1613$
- $F_n = 1 - F_b = 0.8388$
- $K_b = 17 \text{ W/mK}$
- $K_n = 0.024 \text{ W/mK}$
- $K_{eff} = 17(0.1633) + 0.024(0.8388) = \mathbf{2.7962 \text{ W/mK}}$

The cross-sections of both configurations were modelled and subjected to simulations within Therm 7.8. For consistency in analysis, they were exposed to identical boundary conditions as detailed in Table 8, allowing a reliable evaluation of their overall thermal transmittance and resistance. Predictably, Configuration A, equipped with the stainless-steel protective sheet, exhibited a superior thermal transmittance relative to Configuration B. This variance can be attributed to the thermal conductivity metrics: timber's conductivity, at $\lambda = 0.18 \text{ W/m}^2\text{K}$, is vastly inferior to steel's $\lambda = 17 \text{ W/m}^2\text{K}$. Consequently, timber stands out as a far superior insulation material.

A closer examination of the data in Table 11, highlights that the disparity in thermal transmittance between the two configurations is quite marginal, merely spanning 4%. This minimal difference is directly correlated to the 1mm thickness of the stainless-steel sheet. Upon considering the closeness of the thermal transmittance results for both configurations, it becomes evident that the inclusion of stainless steel as a protective layer has not detrimentally affected the performance of the bio-based façade system. However, a point of concern emerges from the pronounced thermal conductivity disparity between steel and timber which presents potential condensation issues, particularly in regions where the timber framework is overlaid by the stainless-steel sheet. A comprehensive preliminary analysis targeting the condensation risk across both façade configurations will be the focal point of the subsequent sections, aiming to provide a clear understanding of the ramifications of integrating a stainless-steel protective layer.















Colour	Façade Component	Thermal Conductivity [$\lambda = \text{W/mK}$]	Emissivity [-]
	Oak Glulam Timber Frame	0.18	0.9
	EPDM Gasket	0.25	0.9
	PTFE	0.25	0.9
	Toggle System	2.76	0.9
	Stainless Steel Sheet	17	0.2
	Silicone	0.35	0.9
	PVC Flexible ^{w/40%} softener	0.14	0.9
	Silica Gel [Desiccant]	0.03	0.9
	Glass	1	0.8
	Fundermax Cladding	0.3	0.9
	Softwood Subframe	0.11	0.9
	Mycelium Insulation	0.03	0.9
	MDF Sheathing	0.14	0.9
	Plywood fibreboard	0.11	0.5

Table 10: Material properties of the proposed bio-based façade system supported by Therm 7.8 Database.

Component	Façade Configuration A - SS sheet			Façade Configuration B		
	U	A	U x A	U	A	U x A
	[U/m ² K]	[m ²]	[W/K]	[U/m ² K]	[m ²]	[W/K]
Vision Mullion	2.172	0.247	0.536	1.931	0.247	0.477
Spandrel Mullion	0.764	0.128	0.098	0.622	0.128	0.080
Intermediary Transom	1.581	0.140	0.221	1.485	0.14	0.208
Consecutive Transom	1.936	0.154	0.298	1.590	0.154	0.245
Glass Edge - Horizontal	1.182	0.165	0.206	1.192	0.165	0.197
Glass Edge - Vertical	1.013	0.258	0.261	1.045	0.258	0.270
Glass Center	0.688	3.014	2.074	0.688	3.014	2.074
Panel	0.041	1.296	0.053	0.037	1.296	0.048
Total		5.402	3.748		5.402	3.597
Overall U -Value [W/m²K]	0.694			0.666		
Overall R -Value [m²K/W]	1.441			1.502		

Table 11: Thermal Performance of proposed bio-based façade system for Configurations A & B.

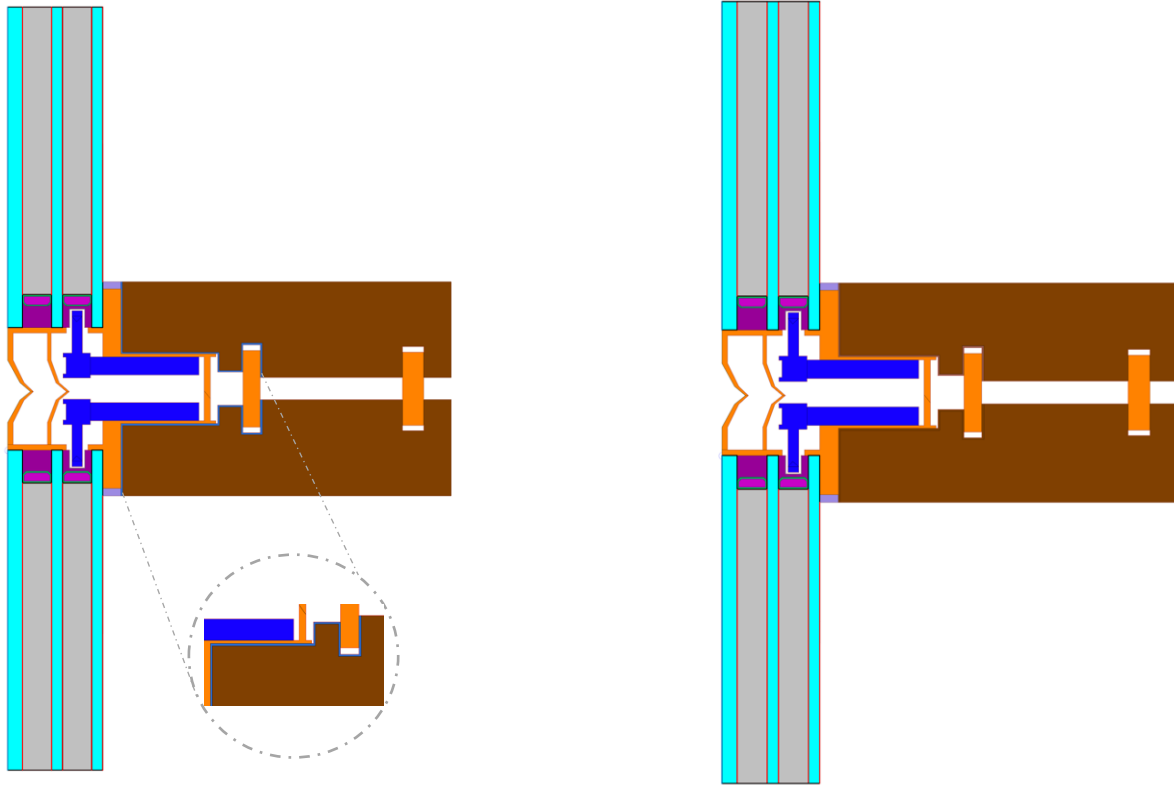

Figure 6.1: Schematic for the material properties of Configuration A (left) & Configuration B (right) for the proposed bio-based façade system mullion. Source: by author







After completing the thermal analysis of the proposed bio-based façade system, attention was directed towards evaluating the thermal performance of the standard aluminium curtain wall system. To ensure the consistency and reliability of the results, the same methodology was employed, following the guidelines set out by EN ISO 1077-2. It's important to note that the aluminium curtain wall façade system mirrors the specifications of the bio-based façade system in terms of dimensions and layout. Both systems consist of a spandrel and a triple glazing unit and are constructed in a unitised façade typology.

The purpose behind determining the thermal performance of the aluminium curtain wall façade system is its use in a comparative environmental impact assessment against the proposed bio-based design concept. For a valid comparison, it's imperative that both systems not only align in terms of dimensions and component arrangement but also exhibit similar thermal performances. Once the thermal performance of the system is comprehended and validated, it sets the stage for Chapter 8, where a detailed environmental impact analysis of the two systems will be undertaken.

The following table shows the thermal transmittance of each mullion, transom, and glazing system part of the aluminium curtain wall unit.

Component	Aluminum Curtain Wall Façade System		
	U	A	U x A
	[U/m ² K]	[m ²]	[W/K]
Vision Mullion	4.56	0.247	1.126
Spandrel Mullion	3.69	0.128	0.472
Intermediary Transom	2.90	0.140	0.406
Consecutive Transom	1.19	0.154	0.183
Centre of Glazing	0.68	3.60	2.476
Spandrel	0.77	1.296	0.998
Total		5.402	5.791
Overall U -Value [W/m²K]	1.072		
Overall R -Value [m²K/W]	0.933		

Table 12: Thermal Performance of Aluminium Curtain Wall Façade System

Colour	Façade Component	Thermal Conductivity [λ = W/mK]
	Aluminium	160
	Glass	1
	EPDM	0.250
	Silicone	0.350
	Polyamide	0.300
	Silica Gel	0.130
	Mineral Wool Insulation	0.035

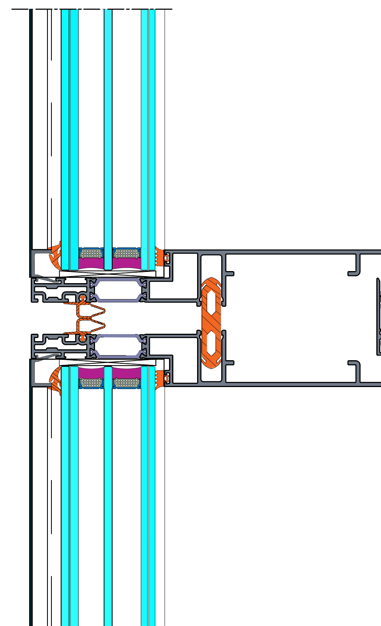

Figure 6.2: Material properties & mullion schematic for the aluminium curtain wall unit. Source: Scheldebouw B.V

6.2.3. Preliminary Condensation Risk Assessment

Despite the minor disparity in the thermal performances between the two façade configurations, the distinction in thermal conductivity between oak glulam and the stainless-steel sheet is markedly evident. These variations, coupled with the positioning of the stainless-steel sheet against the timber frame's outer section as a protective barrier, become a concern regarding a heightened risk of condensation in the shielded timber sections.

Condensation is characterized as the transition of vapour into its liquid phase. Such a transformation is intrinsically tied to fluctuations in both the surrounding ambient temperature and relative humidity that the material encounters. In the quest to comprehend the proclivity for condensation within the façade system cross-sections, determining the dew point becomes paramount. This metric, in essence, represents the threshold at which ambient air must be cooled to attain saturation.

Considering the Netherlands' climatic characteristics, it is observed that during winter, exterior minimum temperatures of -6°C , while interiors remain at 21°C . Coupled with an internal relative humidity of 40%. Such conditions result in a dew point of 8°C . This suggests that as vapour diffuses through the various façade material layers, transitioning from the interior towards the exterior, condensation will manifest in regions where the temperature hits this 8°C mark.

Looking into the timber frame, as vapour navigates through the material, and eventually approaches its exterior interface in contact with the stainless steel, an abrupt temperature decline is evident. This is attributed to the superior thermal conduction capabilities of stainless steel. Consequently, timber sections in direct contact with the stainless-steel sheet, become particularly susceptible to condensation. This not only can compromise the long-term structural integrity of the material but also heightens the risk of mould development.

The preliminary condensation analysis for all proposed bio-based cross-sections for both Configuration A and B have been systematically described, in the appended figure. As it can be observed, the isotherm delineation clarifies the dew point's location within the cross-sections, while the arrows distinguish the specific regions that stand vulnerable to condensation, as discerned from the Therm 7.8 analysis.

It is important to note that the focal points of concern extend beyond just the timber frame. Other façade components, such as the mycelium insulation, fall within the susceptible condensation areas. Therefore, further analysis is needed to understand the material's response to moisture and to explain which protective strategies can be applied to prevent potential material degradation.

Outside Temperature [C]	Inside Temperature [C]	Relative Humidity [%]	Dew Point [C]
-6	21	40	8

Table 13: Boundary Conditions applied to condensation risk assessment analysis in Therm 7.8

- Consecutive Stack Cross-Section

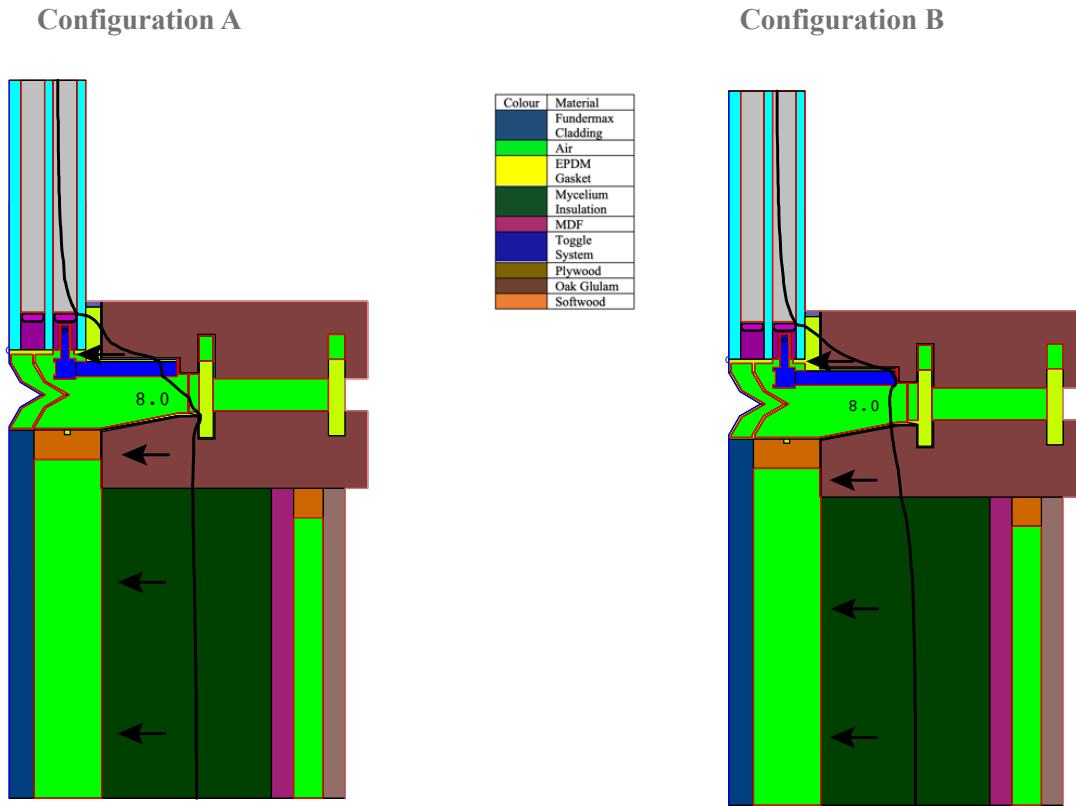
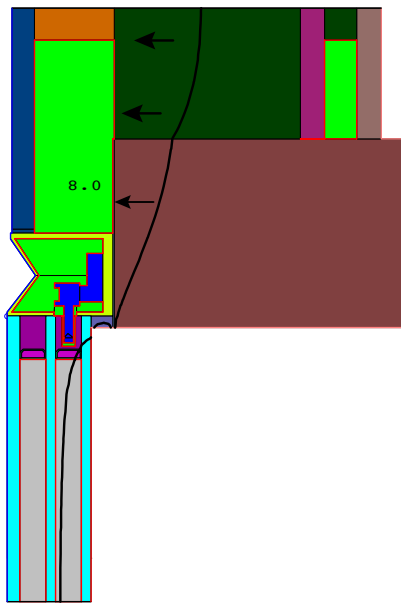

Figure 6.3: Condensation Assessment for Consecutive Stack Cross-Section for Configuration A – stainless steel and Configuration B.

- **Intermediary Transom**

Configuration A



Colour	Material
Blue	Fundermax Cladding
Green	Air
Yellow	EPDM Gasket
Dark Green	Mycelium Insulation
Purple	MDF
Blue	Toggle System
Brown	Plywood
Light Brown	Oak Glulam
Orange	Softwood

Configuration B

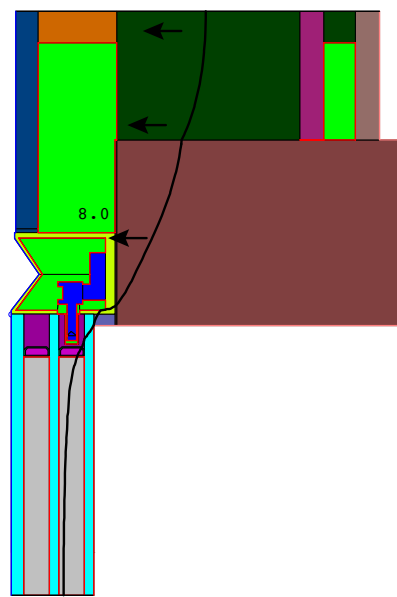
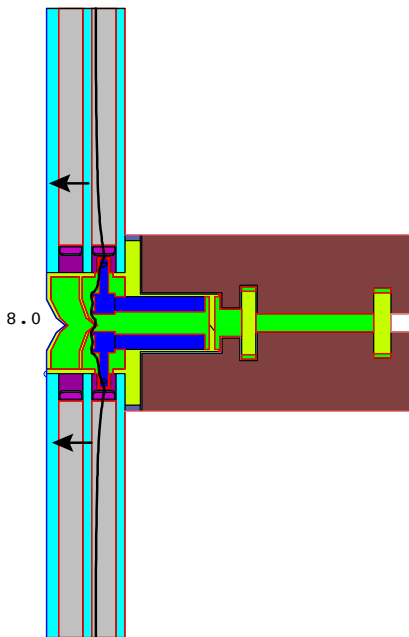

Figure 6.4: Condensation Assessment for Intermediary Transom Cross-Section for Configuration A – stainless steel and Configuration B.

- **Vision Mullion**

Configuration A



Colour	Material
Blue	Fundermax Cladding
Green	Air
Yellow	EPDM Gasket
Dark Green	Mycelium Insulation
Purple	MDF
Blue	Toggle System
Brown	Plywood
Light Brown	Oak Glulam
Orange	Softwood

Configuration B

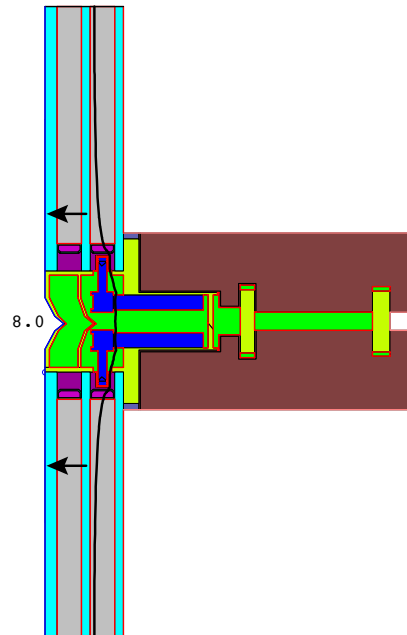

Figure 6.5: Condensation Assessment for Vision Mullion Cross-Section for Configuration A – stainless steel and Configuration B.

- **Spandrel Mullion**

Configuration A

Configuration B

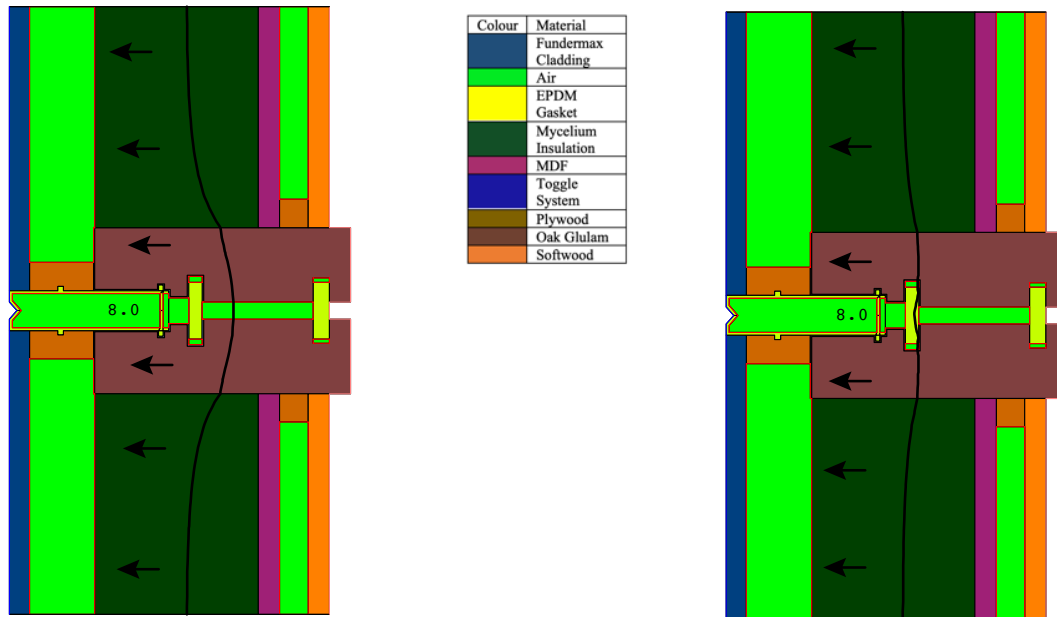

Figure 6.6: Condensation Assessment for Consecutive Stack Cross-Section for Configuration A – stainless steel and Configuration B

6.2.4. Results & Recommendations

After the examination of the thermal analysis and preliminary condensation risk assessment, the influence of the stainless-steel sheet as a protective layer becomes clearer, identifying its ramifications when incorporated within the façade system. While the thermal transmittance of both configurations reflects a negligible divergence, there is a greater risk of condensation in the façade cross-sections' exterior areas connected to the stainless-steel sheet when subjected to colder climates, a consequence of the stainless steel's thermal conduction properties.

However, to derive a better understanding, a hygrothermal analysis is needed to clearly overview the vapour diffusion and moisture transport mechanisms within the façade material layers when exposed to changing climatic conditions.

Regarding the results at this stage and looking at both configurations it can be denoted that the vapour barrier positioned intermediately between the MDF sheathing and the mycelium insulation plays a pivotal role in further lowering the risk of condensation. This is because the vapour barrier principally secures the system's airtightness, consequently diminishing potential condensation threats. It achieves this by limiting moisture air from following a convective route within the assembly towards colder exterior temperatures.

Another factor that might substantially mitigate potential condensation risks in these susceptible regions entails enhancing breathability within the façade cross-sections' exterior sections. This action would support the drying capacity of the materials, thereby ensuring any entrapped moisture is efficiently expelled from the assembly.

Unfortunately, Therm 7.8 is only capable of simulating two-dimensional steady-state heat conduction, which becomes a limitation when trying to account for variations in vapour diffusion and moisture transport among material layers which are needed at this stage of analysis.

Given these limitations, Wufi 2D Motion will be used to conduct the hygrothermal analysis and further analyse the ramifications of the stainless-steel sheet and show a clear depiction of the material behaviour when facing changing climatic conditions, thus testing the impact of weather membranes to improve the efficiency of the façade system. Therefore, the following sub-chapter focuses on the hygrothermal analysis of both configurations to understand the feasibility of adding stainless steel as a protective layer to the façade system and the reaction of the bio-based materials.

6.3. Hygrothermal Analysis

6.3.1. Wufi 2D Motion Set Up

WUFI (Wärme und Feuchte instationär) is a finite analysis software designed to facilitate realistic hygrothermal calculations. Specifically, it evaluates coupled heat, air, and moisture transfer within one and two-dimensional scenarios related to multilayer building components under natural climatic conditions [Wufi 2012]. The validity and performance of WUFI simulations have been thoroughly tested and verified using data from both field and laboratory tests, making it a reliable tool for comprehensive analysis [Kunzel 1995].

Furthermore, the software possesses an extensive range of capabilities. It can account for enthalpy flows accompanying moisture movement, including phase changes, thermal conduction, and vapour phase transfer. Such vapour transfers are measured through both vapour and solution diffusion, while liquid transport mechanisms are represented by capillary conduction and surface diffusion.

For the scope of this case study, the specialized version, Wufi 2D Motion, will be employed. This version analyses the moisture diffusion patterns within the façade's multilayer assembly. Additionally, it clarifies the impacts of relative humidity on the chosen materials, assesses the water content absorption capabilities of these materials, and carries out a condensation risk analysis for both bio-based façade system configurations. To further enhance the depth of this investigation, the Wufi Bio plug-in is utilised. This tool is specifically tailored to analyse risks associated with biodeterioration. In particular, it assesses potential mould development within the various bio-based material components. This is especially crucial given the potential influence the stainless-steel coverage can have on the timber frame and the temperate coastal weather conditions that the assembly is subjected to.

6.3.2. Methodology Overview

The comprehensive hygrothermal analysis for the proposed Bio-based façade system will be segmented into two distinct sub-sections. Initially, the analysis will overview the implications of using stainless steel as a protective layer over the timber frame. Within this framework, both Configuration A & B, with their four cross-sections, will undergo simulation. These simulations, subject to identical climatic conditions and time durations, aim to distinguish the timber frame's drying capacity under the influence of its protective layer.

Additionally, the system will be subjected to additional moisture loads, replicating possible conditions over the lifetime of the façade assembly. This examination will predominantly emphasize the fluctuations in relative humidity experienced by the cross-sections and the subsequent impact on the material's moisture content. Insights derived from moisture content variations throughout the simulation can explain the dimensional stability of the timber, potentially suggesting design or installation adjustments. Concurrently,

a condensation analysis will be undertaken to recognize any latent risks the assembly may face, particularly considering the influence of the protective layer on timber framing.

The subsequent analytical subsection investigates the assembly's spandrel section. This section is composed of organic materials including cladding, insulation, sheathing, and interior lining. Given their organic nature, it becomes important to study the effect of the specific coastal climatic conditions where the assembly is located, ensuring their optimal functionality and feasibility. To recognize the behaviour of these façade components and consequently select those of the highest performance, four distinctive wall typologies are considered. The focus of this comparative study centres on the impact of insulation types as well as the influences of different weather-resistive barriers on the overall façade assembly. These barriers, with differing vapour diffusion properties, offer a solution for moisture migration through the assembly layers, aiming to reduce material degradation. Furthermore, potential mould growth will be examined across timber frame and spandrel typologies within both configurations. This will facilitate a comprehensive understanding of any imminent risks, thus paving the way for effective improvements in the assembly.

It is important to note that the reliability of the hygrothermal assessment lies under the assumption of inputs and parameters. The input parameters are further explained in the following sub-sections but are listed here as, the initial conditions, boundary conditions, schematic and material properties, sources, and air gap configurations. Such parameters have shaped the results of the simulation and have been selected in compliance with the scope of the case study and Wufi Databases supported by European standards.

6.3.3. Initial Conditions

Initial conditions are specified for every façade component in the model. The initial temperature has been set to 20 C and the initial ambient relative humidity to 80 %. A very high relative humidity has been used to analyse the drying capacity of the materials, specifically, the timber frame, whose behaviour against fluctuating weather conditions can bring to light potential future design considerations and upgrades.

6.3.4. Climatic Conditions

The thermal and hygrothermal analysis of the proposed bio-based façade system is subjected to temperate coastal climatic conditions, often named maritime west coast climate. The pilot project of this study is located in the cities of Brussels and Amsterdam, which are areas that display similar meteorological qualities.

The maritime climate is often marked by a lack of severe annual temperature fluctuations, where winters are relatively mild and summers, while warm, remain temperate. However, there is a uniform distribution of rainfall year-round.

Regarding the hygrothermal simulations, climatic data is synchronized with the city of Brussels, in accordance with the ASHRAE Station 064510.

Outdoor Climate

The outdoor temperature and relative humidity are defined per the climatic files of the city of Brussels in compliance with the ASHRAE 160-2016 for the use of 10 consecutive years of measured weather data. The outdoor climatic conditions as seen in Figure 6.7, show a more accurate representation of severe weather conditions in comparison to a typical meteorological year (TMY), [Strang 2021], which ensures the accuracy of the results. The weather files are provided by Wufi Software.

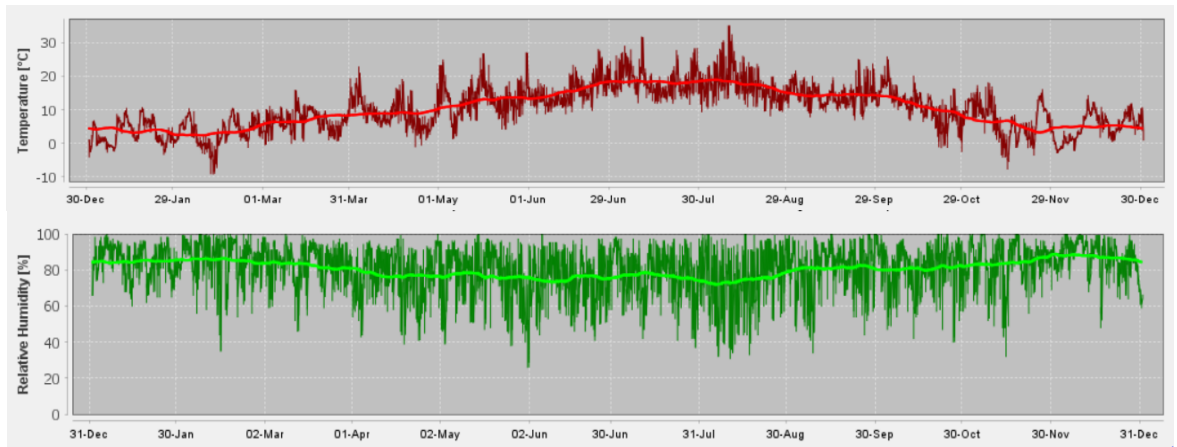

Figure 6.7: Outdoor weather conditions for the city of Brussels. Source: Wufi Software

Indoor Climate

The indoor conditions are created in compliance with EN 15026 (BSI, 2007b). Indoor relative humidity and temperature are formulated from the outdoor conditions previously explained. The indoor relative humidity threshold is set to 60 % defined according to the ASHRAE 160.

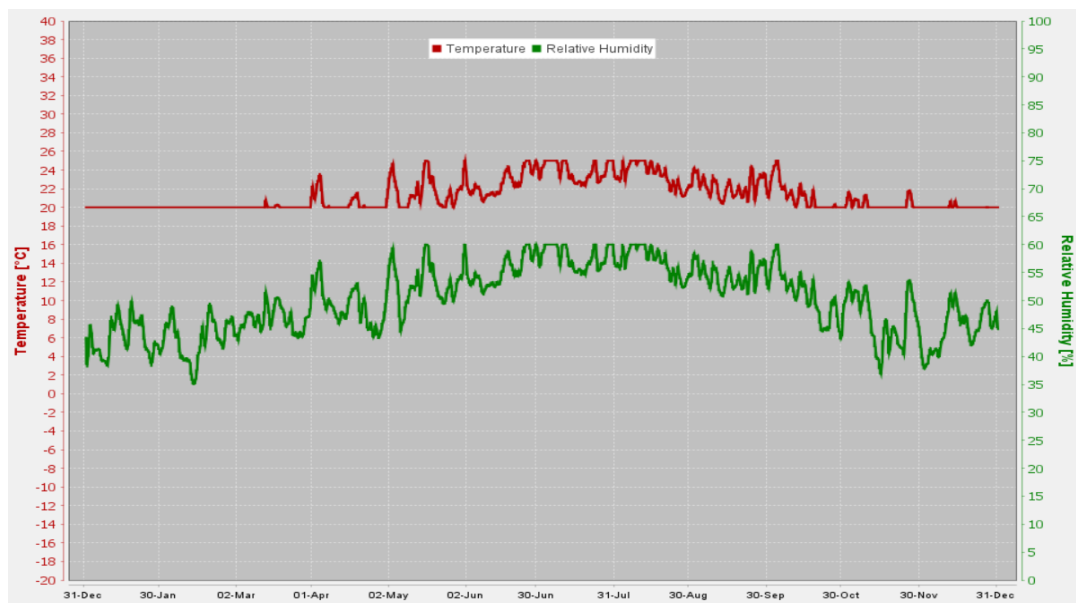

Figure 6.8: Indoor weather conditions to which the proposed bio-based façade system is subjected. Source Wufi Software

6.3.5. Boundary Conditions

The weather is based on Brussels, ASHRAE Station 064510.

- Orientation – The façade direction for this study was specified as South.
- Orientation – Wall Inclination. Walls are designed vertically.
Inclination – 90 Degrees.
- Wind Dependent
- Rain load calculation according to ASHRAE Standard 160 was used.
 - o Rain Exposure Factor (FE) = 1.2 for a building height of 10.8 m

- Rain Deposition Factor (FD) = 1
- Adhering Fraction of Rain = 0.7

Parameters	Exterior	Interior
Heat Transfer Coefficient [W/m ² K]	17	Edge = 1.68 Frame = 2.44
Short- Wave Radiation Absorptivity	0.4	-
Long-Wave Radiation Absorptivity	0.9	-

Table 14: Boundary Conditions used for the simulation of the Bio-based façade cross-sections. Wufi 2D Motion

6.3.6. Schematic & Proposed Materials

Most of the properties of the materials used for this simulation have been provided by the Wufi material database, which is supported by laboratory tests or from literature research. For those specific material properties that were absent from the Wufi database, relevant details were extracted from the technical sheet supplied by the respective product manufacturers. The material properties used in this simulation are in compliance with European Standards.

Materials	Bulk Density [kg/m ³]	Porosity [m ³ /m ³]	Spec.Heat Capacity [J/kgK]	Thermal Conductivity [W/mK]	Water Vapour Diffusion Resistance Factor [-]
Glazing System	2500	0.00001	800	0.124	100000
Oak Glulam Frame	690	0.72	1600	0.18	140
EPDM 60 mm	1500	0.001	1500	0.2	105000
Air Layer 10 mm – Metallic	1.3	0.999	1000	0.04	0.73
SS Sheet d =1mm	8000	0.001	500	17	100000
Air Layer 10 mm – without additional moisture capacity	1.3	0.001	1000	0.071	0.73

Table 15: Material Properties for the Bio-based façade configurations cross-sections. Wufi 2D Motion

6.3.7. Sources

A central modification was made to the cavity by introducing an air exchange source. This was calibrated to exhibit an air rate change of 5 air changes per hour. Furthermore, to replicate real-world scenarios where imperfections might occur, an additional moisture source was placed between the stud and the insulation on the external edge.

This placement mimics situations like leakages or incomplete sealing that might compromise the façade's performance. Specifically, this moisture source has a dimension of 5 mm and has a capacity set at 1% of wind-driven rain. The principal objective behind the incorporation of this moisture source is to measure the insulation's drying capacity and to analyse the potential reach of moisture migration through the various layers of the façade due to improper sealing.

6.3.8. Air Gap Configuration

In the study, three distinct air layers were incorporated to replicate a ventilated air gap capturing the effects of wind and driven rain on the bio-based façade cross-sections. Specifically, the layers on the exterior and interior exhibit a higher porosity and an enhanced moisture capacity, characteristics intended to mirror real-world conditions. However, the central area was simulated using an air layer with reduced porosity and the absence of additional moisture capacity. This was designed to represent the natural air circulation typically observed within building façades. Despite their varied properties, all the air layers were maintained at a consistent thickness, ensuring uniformity in physical dimensions.

6.3.9. Computational Parameters

The simulation for both bio-based façade configurations starts July 1st and lasts for a period of 26280 hours which accounts for 3 years using hourly time steps. The period has been set for 3 years to analyse the behaviour of the system under repetitive cycles and to study any potential water retention and material deterioration through the cycles.

6.3.10. Critical locations to be analysed

In the examination of the timber frame, both the timber mullions and transoms are being inspected. The primary goal is to identify regions especially prone to moisture issues, which can manifest as dimensional variations, moisture retention, and material decay. However, special attention is directed toward those sections of the timber that are in contact with the stainless-steel covering sheet. This focus is to find out the repercussions if any, of the coverage on the timber frame.

Regarding the spandrel analysis, the different material layers in the spandrel configuration called for a segmented analysis approach. A total of five distinct analysis zones have been set for investigation, each with a focus on understanding the influence of natural climatic variables on the performance of the wall configuration.

Starting with, Analysis Zone 1, positioned at the exterior edge of the insulation has been selected as a critical point for condensation, especially during the colder months. Its placement facilitates the analysis of moisture diffusion when exposed to varying weather-resistive barriers.

Meanwhile, Analysis Zone 2, located on the warmer side of the insulation, is set to provide information on moisture retention within the material, as well as any potential mould formation. Additionally, it serves as a diagnostic lens to discern how different insulating materials can influence mould propagation and material permeability.

The third and fourth analysis zones are on the edges of the MDF sheathing. Their strategic positioning facilitates a study of possible summertime condensation, when the dynamic of heat flow and moisture transportation reverses, transitioning from an outward to an inward trajectory. Lastly, Analysis Zone 5 is placed at the edge of the plywood board. Its role is to analyse any mould development on the façade assembly's inner face.

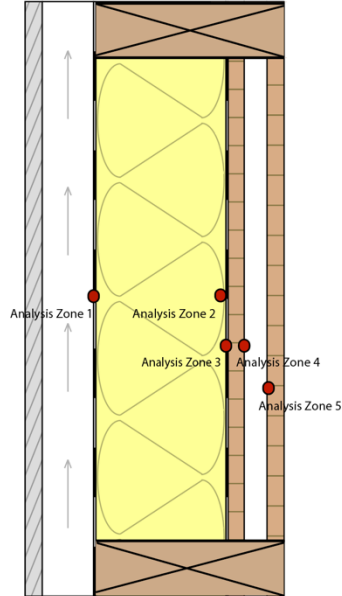

Figure 6.9: Schematic Representation of the analysis zone location of the wall assembly. Source: by author

6.4. Impact of Stainless-Steel Sheet on Timber Framing

6.4.1. Relative Humidity

Upon defining the weather conditions and establishing the initial parameters, the cross-sections delineated under Configurations A & B, as represented in Figure 6.10, undergo the same simulation process. Central to the software's functionality is its ability to study the progression of heat and moisture distributions within building components over time. This evolution is predominantly driven by exchanges with the surrounding environment, composed of indoor and outdoor air conditions.

This interaction is particularly evident as moisture flows migrate through the surfaces of the analysed materials into their surroundings. These surroundings are characterized by a range of meteorological factors, including relative humidity, temperature, water content, and solar radiation. Under the relative humidity parameters, this case study has set the indoor design humidity in compliance with the ASHRAE 160 intermediate methodology.

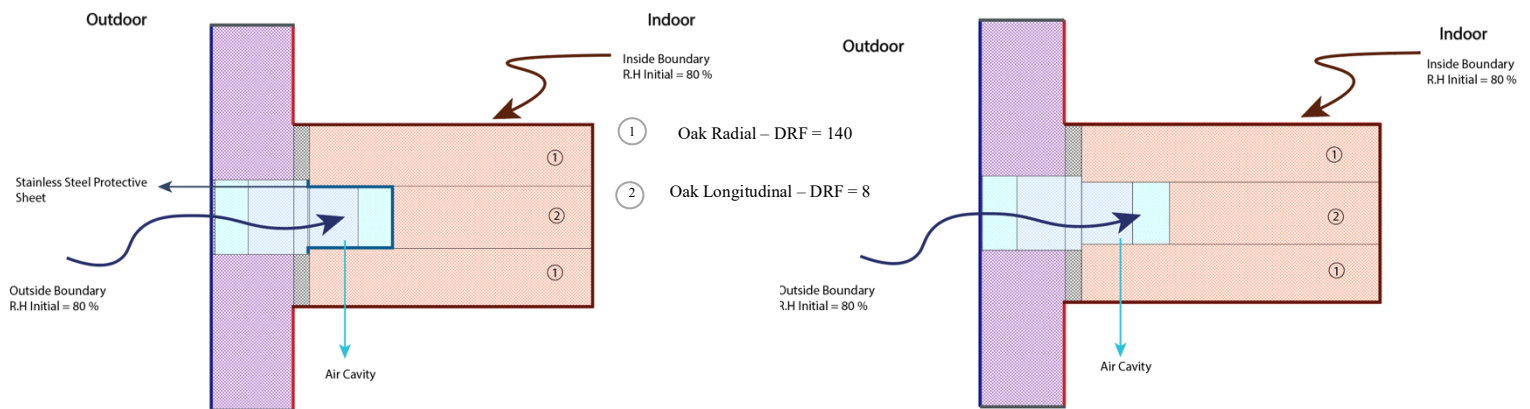

Figure 6.10: Vision Mullion Schematic for Configuration A (left) and Configuration B (right) modelled in Wufi 2D.

In this section, a thorough assessment of the relative humidity variations over three years on the timber frame's surface is investigated. Relative Humidity (RH) emerges as a pivotal parameter, for in collaboration with temperature, it governs the dynamic of moisture exchange between timber and the ambient air. Elevated RH implies increased moisture availability in the air, directly influencing the timber. Given timber's inherently hygroscopic quality, it continually absorbs and releases moisture to achieve equilibrium with its environment. Therefore, fluctuations in RH bear significant implications for timber's mechanical properties and, by extension, its durability.

Referencing Figure 6.10, which depicts the schematic of the vision mullion cross-section, it's evident that timber mullion's surface RH is influenced by both interior and exterior RH values. The external RH prominently affects the outer timber regions connected to the air cavity. In Façade Configuration A, the timber benefits from the protection offered by both the exterior gasket and the stainless-steel sheet. However, Façade Configuration B only possesses the gasket, making the timber more exposed to environmental conditions.

The RH trends, observable in Figure 6.11, delineate the fluctuations over a three-year simulation period for all cross-sections in both configurations. Highlighted by dotted markers accentuate the peak highs and lows. Considering these critical points, other parameters such as temperature, water content, and moisture content during these instances were also recognized. An analysis reveals that Configuration A, covered with a stainless-steel protective sheet, registers elevated RH values compared to the standard façade system, Configuration B. This suggests that the stainless-steel layer potentially impedes moisture diffusion, leading to heightened RH levels on the timber frame's surface.

Moreover, a stabilization in RH values is observed across all cross-sections by the third year, indicating optimal drying capabilities of the material. Another point of observation is that the vision mullion and the consecutive stacked timber transom in both configurations experience more pronounced RH fluctuations, but their values are comparatively diminished. Given that these components are not in contact with other façade elements, it emphasizes the timber's innate hygroscopic behaviour, enabling it to modulate moisture effectively. On the contrary, timber frames in proximity to other façade elements demonstrate consistent and elevated RH levels, suggesting the effects of moisture transmission and heat conduction from the façade materials. To further investigate the implications of this on the timber and understand the moisture diffusion

effects, it's key to explore moisture content trends within the timber. The subsequent section investigates the effects of moisture within the timber structure.

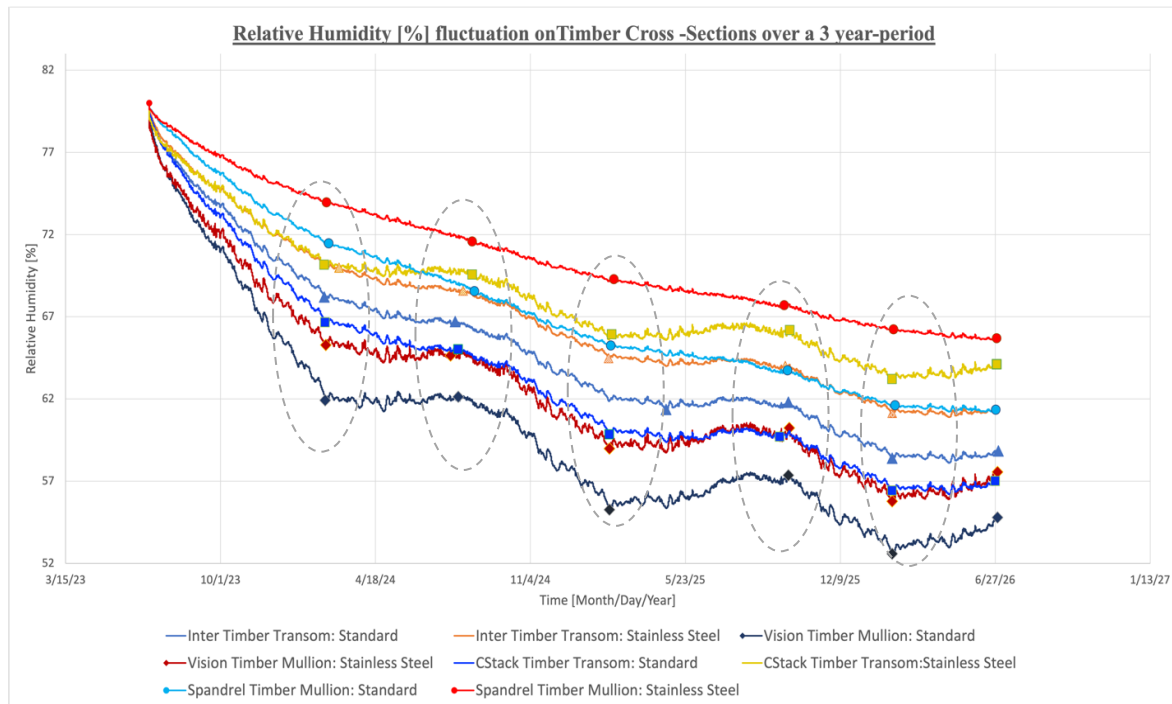

Figure 6.11: Relative Humidity Fluctuation over the 3 years for both façade system configurations cross-sections.

6.4.2. Moisture Content

In this sub-section, a deeper study into the moisture content dynamics of the timber frame across both façade configurations over the three-year simulation span is presented. Due to an elevated initial relative humidity, the timber's moisture content starts at 16%, based on the assumption that the analysed timber section has attained equilibrium. Predictably, the trajectory of moisture content mirrors that of relative humidity. Across the years, a consistent decline in moisture content is observed, with more pronounced reductions in timber sections not in contact with other façade components.

As noted in the previous section, the incorporation of the stainless-steel sheet as a protective covering on the timber's exposed areas increases the material's moisture content. However, these differences are marginal, with an average increase of around 1% for all timber sections. Such minimal variation is attributable to the stainless-steel sheet covering only a minor portion of the timber surface. This moisture retention is supported by the properties of stainless steel, which has a very high vapour diffusion resistance factor, making the material impermeable.

Referring to Figure 6.10, which provides a schematic of the vision mullion, it becomes evident that the timber's vapour diffusion resistance factor is not uniform across its span, due to its inherently anisotropic character. The factors for the longitudinal grain orientation and the radial one are distinguished as 8 and 140, respectively, making the longitudinal section of the timber especially susceptible to moisture retention. It is important to note that the models used for the simulation are simplified to improve the accuracy of the results. The actual cross-sections as seen in Chapter 5, are composed of two transoms or mullions connected by interlocking gaskets, where the longitudinal areas are the parts of the timber sections exposed to the air cavity.

To understand the behavioural properties of oak glulam against moisture, it's important to consider its bulk density. Bulk density is a critical parameter, as it not only correlates strongly with mechanical attributes like strength, hardness, and surface abrasion [Cabral 2022], but it also exerts an influence on moisture content. A denser composition implies fewer voids within the wood's microstructure, resulting in slower moisture diffusion and diminished initial moisture content. The oak glulam, designated for this study, accounts for a bulk density of 690 kg/m³, situating it in the medium to high-density spectrum when compared with other oak glulam variants. This high density makes the material more compact, thereby slowing moisture diffusion. Consequently, the addition of the stainless-steel layer potentially escalates the moisture retention within the timber section, augmenting the moisture content and preventing its evaporation or drying. Such conditions are conducive to potential condensation and mould development. While the differences in moisture content are seemingly negligible, to understand the actual necessity of stainless steel as a protective barrier—or to determine the intrinsic robustness of oak glulam in counteracting climatic exposure—it's imperative to evaluate the material's dimensional stability and undertake a thorough condensation analysis.

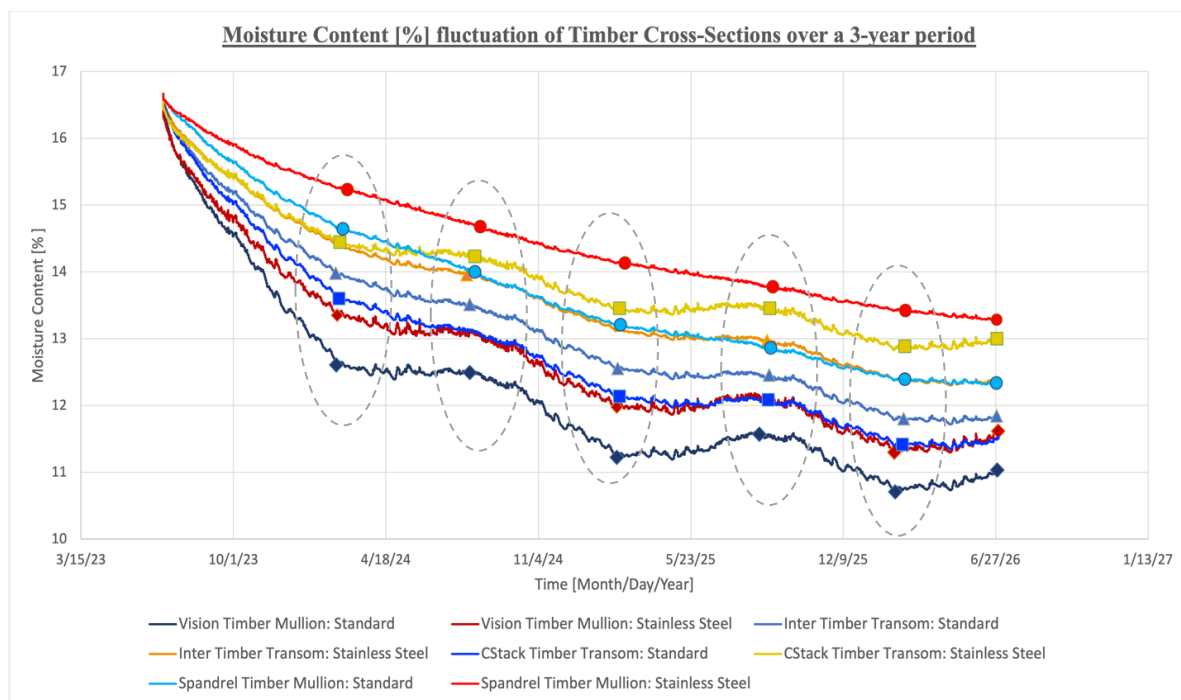

Figure 6.12: Moisture Content Fluctuation over the 3-year period for both façade system configurations cross-sections.

6.4.3. Dimensional Stability

The moisture content within timber is a pivotal determinant of its mechanical characteristics. This is primarily attributed to wood's inherent hygroscopic nature, allowing it to continuously absorb and release moisture when exposed to ambient conditions. Such exchanges naturally result in dimensional alterations: swelling as the wood absorbs moisture and shrinking upon moisture loss.

The diffusion of moisture across the wood's cross-section isn't uniform and is significantly influenced by temporal variations in climatic conditions, [Franke 2016]. Observations from the moisture trajectories for both façade configurations further substantiate this claim. Therefore, these moisture gradients induce stresses across the timber cross-section, which could culminate in material cracks.

Given these potential ramifications, conducting a detailed analysis of the timber frame's shrinking and swelling behaviour for both configurations becomes imperative. To facilitate this, Table 16 presents the oak glulam's physical properties, critical for calculating the timber frame's dimensional alterations.

Oak Glulam Density [Kg/m ³]	Timber Mullion Volume [m ³]	Timber Mass Dry [kg]	MC _{fs} [%]	Radial Shrinkage [%]	Tangential Shrinkage [%]
690	0.07	48.36	28	5.6	10.5

Table 16: Mechanical properties of European oak glulam.

By following the provided formula and referencing the marked peaks within the moisture content trajectory, both shrinkage and swelling for each configuration are computed. According to Glass, 2010:

$$D_c = \frac{D_i(MC_i - MC_f)}{\frac{MC_{fs}(100)}{RS \text{ or } TS} - MC_{fs} + MC_i}$$

Where:

1. D_c = Dimensional change [mm]
2. D_i = Initial dimensions [mm]
3. MC_i = Initial Moisture Content [%]
4. MC_f = Final Moisture Content [%]
5. MC_{fs} = Fiber Saturation for European Oak [%]
6. RS = Radial Shrinkage for European Oak [%]
7. TS = Tangential Shrinkage for European Oak [%]

Initial dimensions [D_i] of the timber cross-sections, based on their grain orientation, are depicted in the subsequent figure for the mullions and transoms.

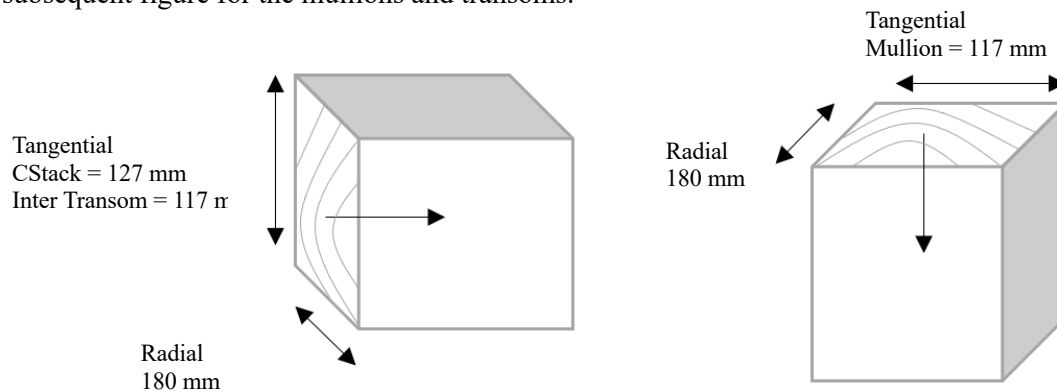

Figure 6.13: Initial Dimensions of timber mullion and transoms based on its grain orientation.

A main observation from the analysis reveals that the shrinkage and swelling percentages for the transoms and mullions during the first year are at their peak. This is primarily driven by the elevated relative humidity levels initially present. As time progresses, evident from the moisture trajectory, the timber in both configurations appears to stabilise, evidenced by diminishing moisture content fluctuations and, consequently, reduced shrinkage and swelling rates.

Consistently, all timber cross-sections exhibit a cyclic shrinking and swelling behaviour—expansion during the warmer months and contraction in winter, mirroring the fluctuations in relative humidity. Yet, an

exception arises in the spandrel mullion. Here, the moisture absorption rates are persistently lower than the desorption rates, resulting in a consistent shrinking pattern, as can be perceived in the figures below.

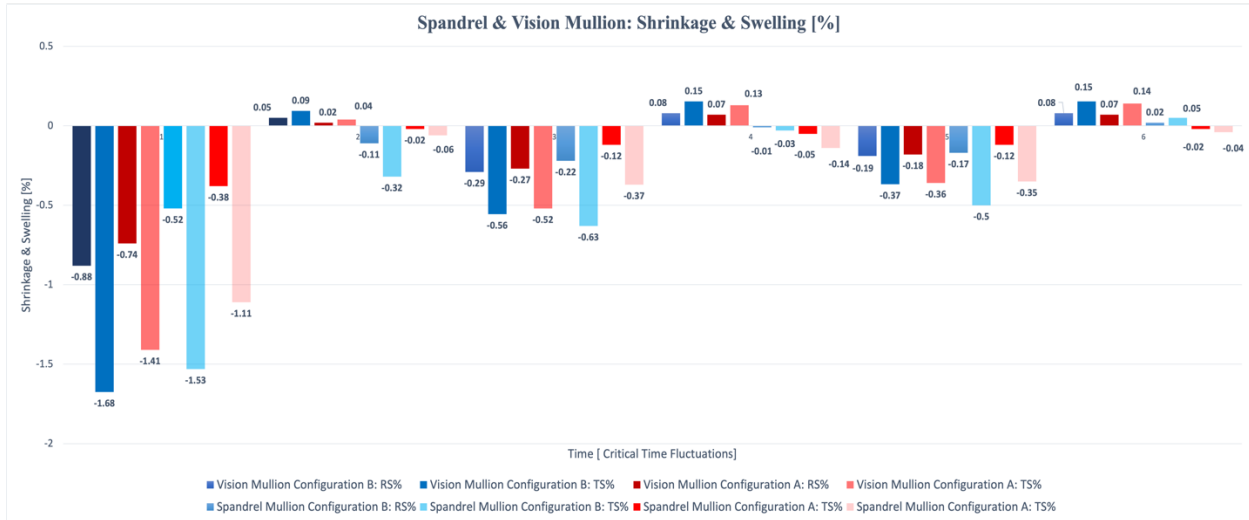

Figure 6.14: Tangential & Radial Shrinkage and swelling [%] comparison in the vision and spandrel mullion for both configurations.

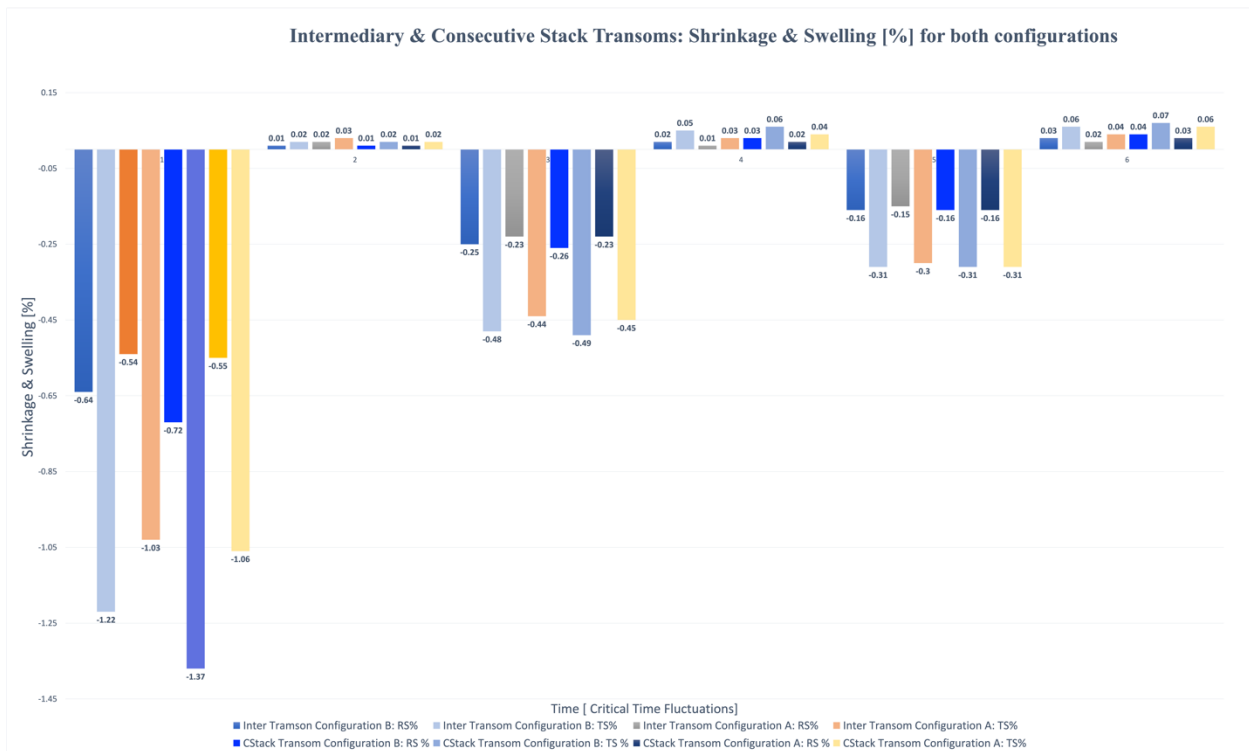

Figure 6.15: Tangential & Radial Shrinkage and swelling [%] comparison in the Intermediary and Consecutive Stack Transom for both configurations.

This phenomenon in the spandrel mullion can be attributed to its interaction with other façade components, including insulation, MDF sheathing, and plywood. The interplay of moisture between these elements and the timber surface ensures that the mullion retains a relatively consistent moisture content. Yet, the timber's inherent slow moisture diffusion characteristics, combined with the continual moisture influx from the façade elements, reduce the typical cyclic moisture content variations, thus reducing the swelling pattern in this section.

The impact of the stainless-steel covering sheet on the dimensional stability of the system is also reviewed. Its introduction tends to reduce the shrinking and swelling values of the cross-sections when compared to the standard timber frame. This is because the stainless-steel impermeable properties act as a barrier blocking moisture diffusion in the material. Although reducing cyclic shrinking and swelling is a positive outcome, water retention can become an issue since as already noted can lead to material decay and a failure of the mechanical properties of the timber.

Upon reviewing the two façade system configurations, the differential in their dimensional changes emerges as relatively small, accounting for less than 1%. To clarify such a difference, Tables 17 & 18, show the dimensional changes for both configurations in [mm].

This observation accentuates the inherent resilience of oak glulam on its own, reinforcing its capacity to endure climatic changes while preserving its structural integrity.

Cyclic Fluctuations	Vision Mullion				Spandrel Mullion			
	Configuration A		Configuration B		Configuration A		Configuration B	
	RS [mm]	TS [mm]	RS [mm]	TS [mm]	RS [mm]	TS [mm]	RS [mm]	TS [mm]
1	-1.33	-1.65	-1.58	-1.96	-0.94	-1.79	-0.68	-1.30
2	0.04	0.05	0.09	0.11	-0.19	-0.37	-0.04	-0.07
3	-0.49	-0.61	-0.52	-0.65	-0.39	-0.74	-0.22	-0.43
4	0.12	0.15	0.15	0.18	-0.02	-0.04	-0.09	-0.16
5	-0.33	-0.42	-0.34	-0.43	-0.3	-0.58	-0.21	-0.41
6	0.13	0.16	0.15	0.18	0.03	0.06	-0.03	-0.05

Table 17: Shrinkage & swelling in [mm] for both facade configurations based on the radial & tangential initial dimensions

Cyclic Fluctuations	CStack Transom				Intermediary Transom			
	Configuration A		Configuration B		Configuration A		Configuration B	
	RS [mm]	TS [mm]	RS [mm]	TS [mm]	RS [mm]	TS [mm]	RS [mm]	TS [mm]
1	-0.99	-1.24	-1.30	-1.60	-0.97	-1.21	-1.15	-1.43
2	0.02	0.02	0.02	0.02	0.04	0.04	0.02	0.02
3	-0.41	-0.53	-0.47	-0.57	-0.41	-0.52	-0.45	-0.56
4	0.04	0.05	0.05	0.07	0.02	0.04	0.03	0.06
5	-0.29	-0.36	-0.29	-0.36	-0.27	-0.35	-0.29	-0.36
6	0.05	0.07	0.07	0.08	0.04	0.05	0.05	0.07

Table 18: Shrinkage & swelling in [mm] for both facade configurations based on the radial & tangential initial dimensions

To further understand the influence of ambient air on timber, particularly regarding its moisture equilibrium under the presence of the stainless-steel sheet, a detailed analysis was conducted. Specifically, timber mullions and transoms were isolated for this study. These timber sections were investigated in a controlled environment where both the temperature and relative humidity were maintained constant at 21°C and 80%, respectively.

Initial conditions for the timber, as per the manufacturer's guidelines, were established with a relative humidity of 60% and a moisture content of 12%. The primary objective of this study was to investigate the duration required for the material to reach equilibrium moisture content under consistent indoor and outdoor relative humidity, and to identify if any regions of the material fall behind in achieving this equilibrium, thus making them more prone to potential dimensional changes.

Given the constant relative humidity and temperature, the Equilibrium Moisture Content (EMC) can be calculated. For both timber configurations, the EMC was set to be 16%. These configurations were then subjected to a simulation period of five years, with the resultant moisture content trajectories shown in a subsequent figure.

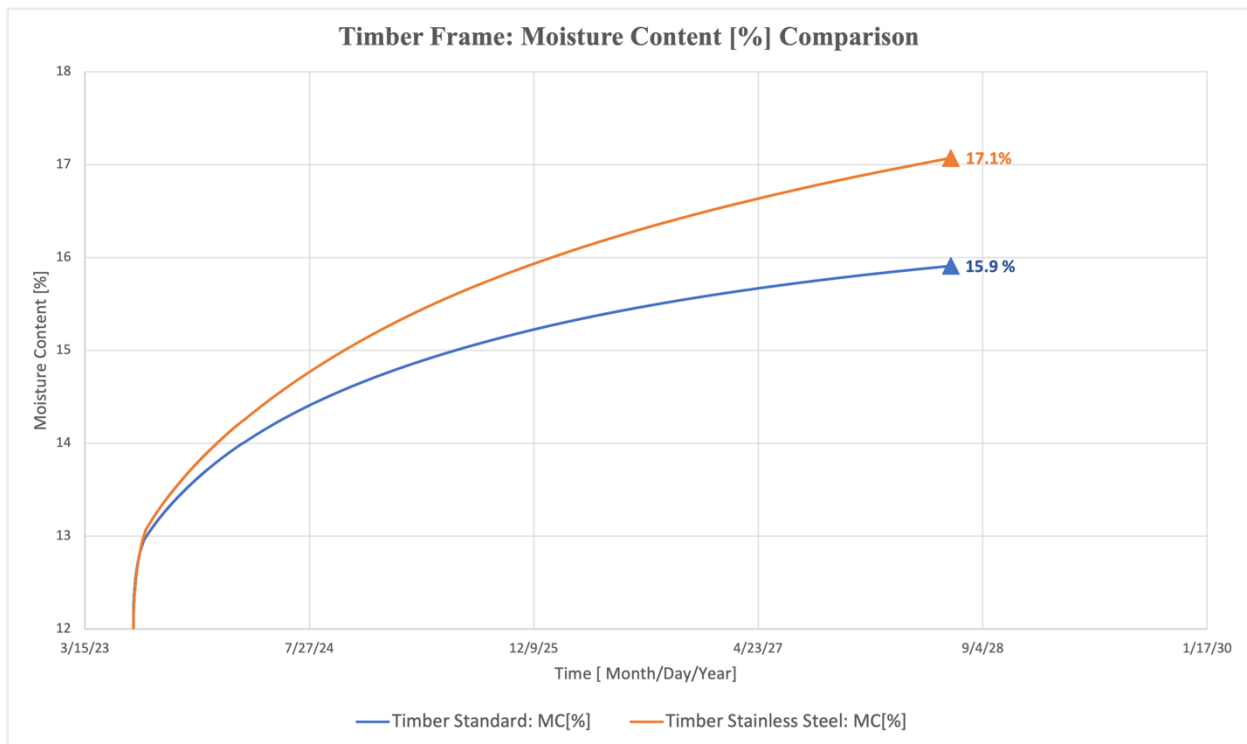

Figure 6.16: Moisture Content [%] comparison for the timber mullion and transoms for both configurations.

The findings revealed that the timber configuration with no protective layer was very close to reaching equilibrium. In contrast, the section covered by the stainless-steel sheet surpassed this equilibrium threshold. However, it's important to emphasise that these trajectories offer a mean representation of the overall timber area. Due to the anisotropic nature of timber, and the variability in the vapor resistance factors dependent on grain orientation, a further analysis showing the moisture diffusion isolines through the material's surface is needed.

This analysis helped clarify the moisture dispersion trajectories within the timber sections, where the standard timber section predominantly achieved equilibrium moisture content. However, an exception was

the delineated blue section, which fell behind, recording a moisture content of 14.8% as can be observed in the following figure.

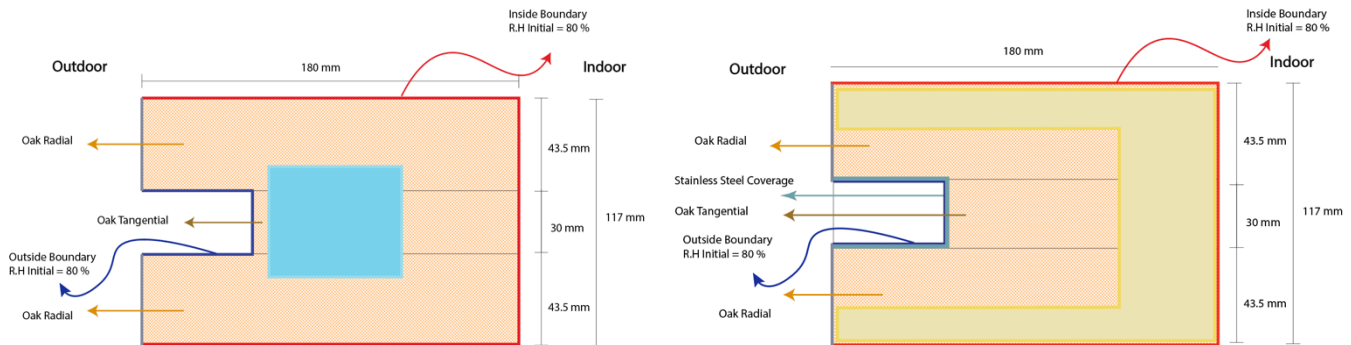

Figure 6.17: Timber Schematic for both configurations exposing susceptible areas to dimensional change.

This behaviour aligns with the intrinsic properties of oak glulam, which, owing to its denser composition, manifests a slower moisture diffusion. Consequently, surface-adjacent areas reached equilibrium more rapidly than the central portions. It's important to note that this is a simplified model, and the middle section represents the adjacent timber areas that are connected by a gasket and in contact with the air cavity.

Contrarily, the timber section with the stainless-steel sheet exhibited a region highlighted in yellow, reflecting a moisture content of 17%. This indicates the material's inclination to absorb moisture, induced by the elevated relative humidity in the surroundings. Therefore, making such sections prone to swelling. Comparing the two scenarios, it's evident that the standard timber section, characterized by the blue-marked region vulnerable to shrinking, could benefit from an optimised gasket design to improve its protection against moisture ingress. Thus, reducing the moisture transport to the material. Additionally, the incorporation of membranes into the exposed timber could help regulate vapour ingress while ensuring material breathability. In contrast, the configuration with the protective layer, particularly the marked areas exposing water retention, emerges as a concern, since the material is releasing water at a slower rate than absorbing it. Also, the breathability in the material is limited due to the protective layer. Therefore, the risk of biodeterioration is accentuated and potential damage to the mechanical properties of the material becomes relevant. Further investigation is needed to understand the impact of vapour retention in the timber; thus, a condensation analysis and mould growth assessment are needed.

6.4.4. Condensation Risk Assessment

Condensation risk within building materials is a pivotal concern, especially when such materials constantly interface with the ambient atmosphere as is the case of the timber frame. The assessment of this risk is dependent on an examination of two critical parameters: the saturation pressure and the actual vapour pressure on the material's surface.

When assessing timber, comparing its surface saturation trend with its actual vapour pressure provides a clear depiction of potential condensation over the given simulation period. The proximity of the two trajectories offers valuable insights. Specifically, if the actual vapour pressure of the timber's surface reaches or surpasses its saturation threshold, condensation will inevitably occur under those climatic conditions. Understanding the specifics of these conditions is indispensable to improve indoor climate settings and also optimise the preliminary design of building systems.

For this study, both configurations across the four cross-sections were reviewed. Following the formula below detailed by [Glass 2010]

$$P_{sat} = 100 * e^{18.956 - \frac{4030.18}{T+235}}$$

$$P_t = R.H * P_{sat}$$

Where:

T = temperature in Celsius

$R.H$ = relative humidity in decimal

Calculations for both saturation and actual vapour pressures were made. The results shown in the following figures present a recurrent trend across the cross-sections: the current vapour pressure consistently diverges from its saturation line. This separation suggests the timber's propensity to release moisture, thus stabilising itself with the surrounding environment, and further emphasizes its superior drying capacity.

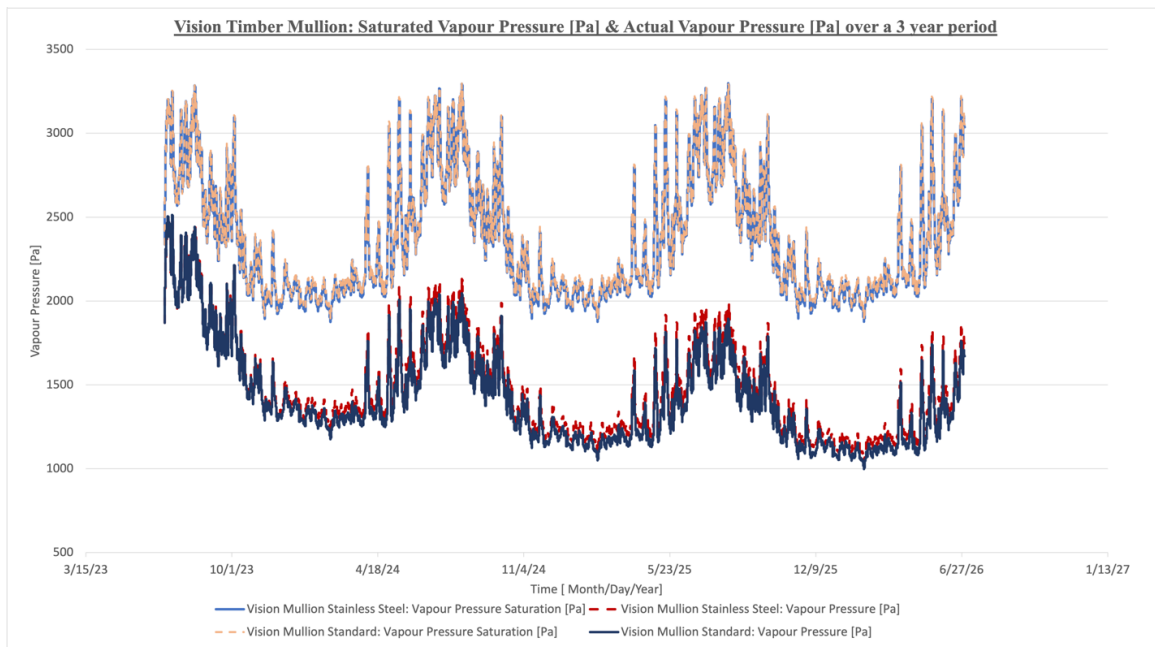

Figure 6.18: Condensation analysis potential for vision timber mullion provided by Wufi 2D.

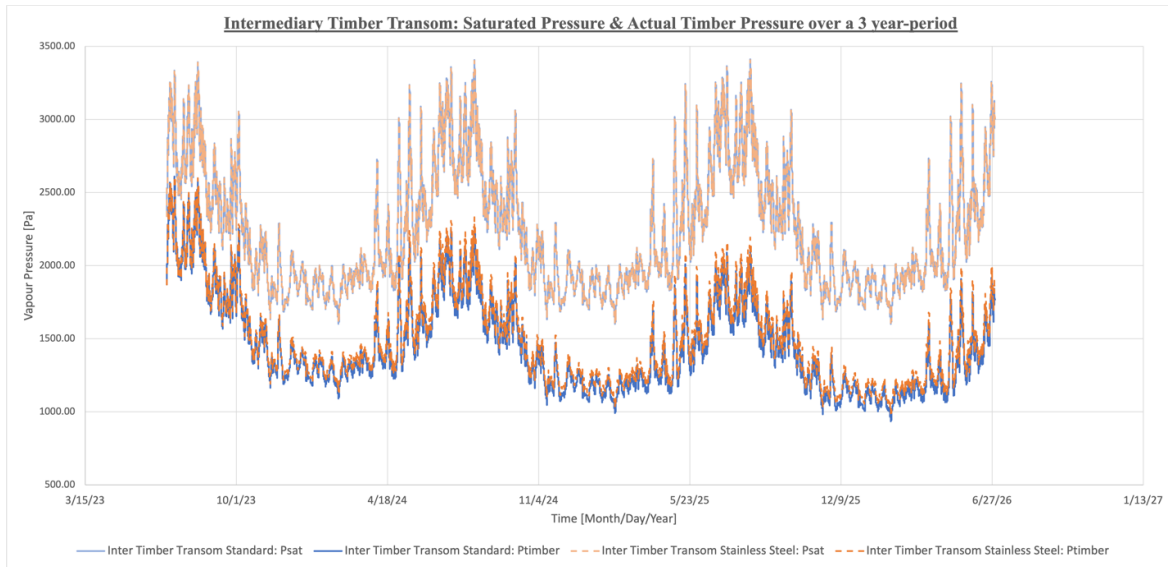

Figure 6.19: Condensation analysis potential for intermediary timber transom provided by Wufi 2D.

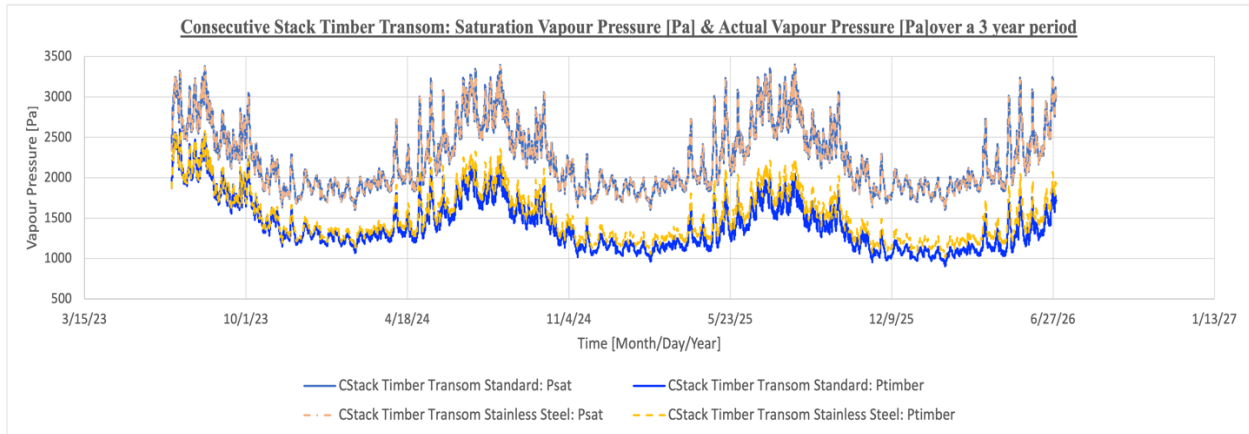

Figure 6.20: Condensation analysis potential for the consecutive stack transom provided by Wufi 2D.

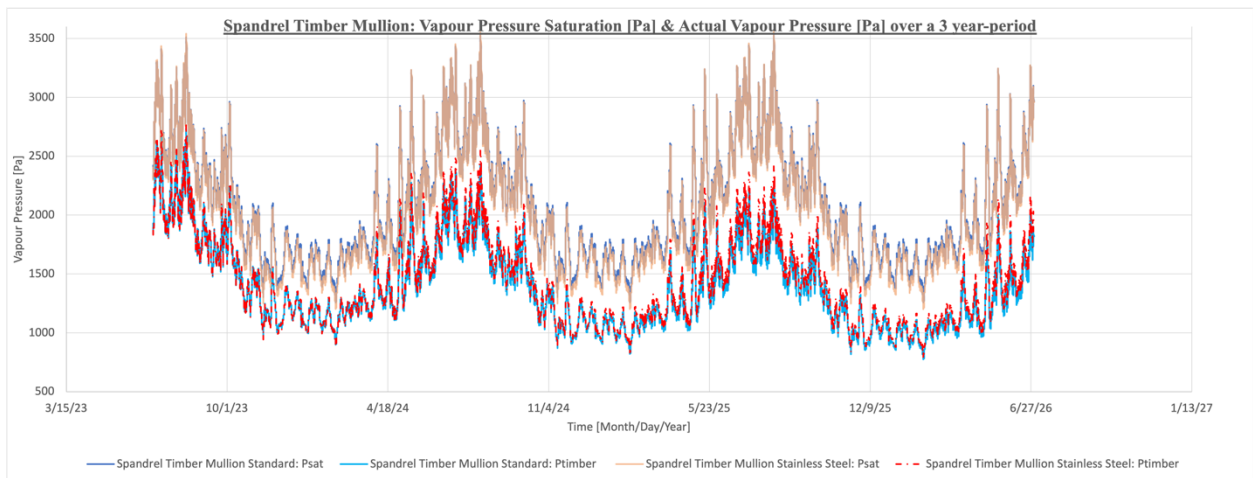

Figure 6.21: Condensation analysis potential for the spandrel timber mullion provided by Wufi 2D.

Yet, introducing the stainless-steel sheet to the system adds concern. As expected, this addition increases the surface's vapour pressure, elevating the potential for condensation. While the discrepancy between the two configurations appears minimal, the implications are more pronounced in the context of the spandrel mullion. Given that this section already exhibited a high risk without the stainless-steel sheet, the incorporation of the protective layer accentuates the threat.

Therefore, a reevaluation of the cross-section, with the integration of a vapour barrier membrane between the timber mullion and façade components can help reduce the condensation potential, since the vapour movement from the façade components to the timber frame, will be reduced. Thus, allowing the material to release moisture without regaining it so quickly.

Also, an examination of water content patterns in timber across both configurations was conducted. Trends in water content were found to mirror those of moisture content, reflecting a consistent tendency towards moisture release.

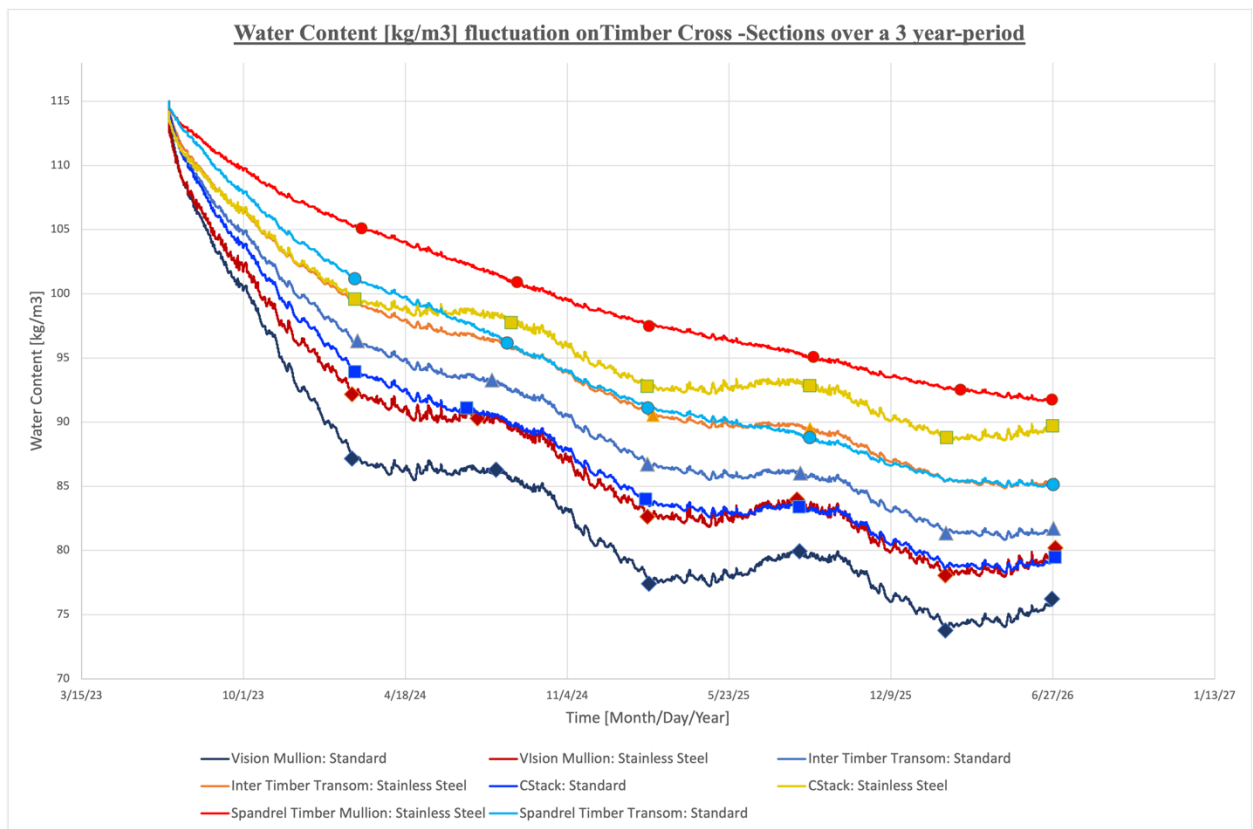

Figure 6.22: Water Content [kg/m3] behaviour of the timber frame under both configurations provided by Wufi 2D.

6.4.5. Mould Growth

Mould-induced biodeterioration is a significant concern in building materials, leading to a diminished service life of building components and resulting in elevated repair and maintenance expenses [Verdier, 2014]. Beyond the structural implications, mould proliferation compromises indoor air quality, posing a threat to human health and well-being. In addition, these manifestations can appear just a few years post-construction, enhancing the necessity for mould analysis during the design phase. Key factors promoting mould growth include architectural and design strategies that overlook moisture-related challenges, inadequate indoor environment, ventilation, and unsuitable operational and maintenance approaches. Specifically, conditions of elevated temperature, humidity, water presence, and nutrient availability are

most conducive for spore germination [WufiBio 2015] Thus, the choice of construction materials, especially concerning their vapour permeability, hygroscopic properties, and organic compound composition, plays a pivotal role in mould prevention.

Given the organic nature of the façade components in this case study, mould development analysis is paramount. Timber is particularly conducive to mould growth. [Gradeci 2017], Consequently, this study seeks to uncover enhanced moisture-oriented design strategies, improving timber protection from biodeterioration and optimising its performance. For this analytical study, the Wufi Bio plug-in for the Wufi software has been employed to model potential annual mould growth on material surfaces. Additionally, the mould index (MI) is calculated in alignment with the ASHRAE 160 Limit, details of which are presented below.

Traffic Light	Level of Risk	Mould Index (MI) ASHRAE 160 Limit	IBP Model Mould growth (mm/year)
Green	Usually, acceptable	MI <1	Growth <129 mm/year
Yellow	Additional investigations are needed	1 < MI < 2	129 < growth < 176
Red	Usually not acceptable	MI >2	Growth > 176 mm/year

Table 19: Analysis Scale set by Wufi Bio according to ASHRAE 160.

To understand the risk for mould development, four cross-sections for both façade configurations were examined for mould proliferation, all subjected to consistent parameters. Timber, in this simulation, was represented by substrate class 0 – which represents the maximum possible growth for any mould development found in buildings [Wufi Bio 2015]

Occupant Exposition Class	Initial R.H in pore	Substrate Class
Indoor surface in contact with to indoor air	0.5	Class O – Optimal Culture Medium

Table 20: Input parameters for mould growth analysis provided by Wufi Bio.

The findings as expected from the previous analysis resulted that the incorporation of stainless steel does improve the threat of mould, as it prevents moisture diffusion in the material generating moisture retention, a primary enabler for mould growth. Even though, the use of stainless-steel does impact mould growth development, the vision mullion, intermediary, and consecutive-stack transom for both configurations displayed no risk for potential mould proliferation, according to Wufi Bio analytical scale.

However, the spandrel mullion in configuration A, with stainless steel, manifests a concerning potential mould growth rate of 218 mm/year – a risk threshold scored as unacceptable. While, its unprotected counterpart registered a 143 mm/year rate, marking a 34% risk diminution.

Drawing from these results, it's clear that prioritizing breathability in façade design is important to reduce any potential material decay. This importance is amplified for bio-based materials which, owing to their hygroscopic characteristics, are inherently more vulnerable to moisture stresses.

Traffic Light	Level of Risk	Mould Index (MI) ASHRAE 160 Limit	IBP Model Mould growth (mm/year)
Green	Usually, acceptable	MI <1	Growth <129 mm/year
Yellow	Additional investigations are needed	1 < MI < 2	129 < growth < 176
Red	Usually not acceptable	MI >2	Growth > 176 mm/year

Table 21: Analysis Scale set by Wufi Bio according to ASHRAE 160.

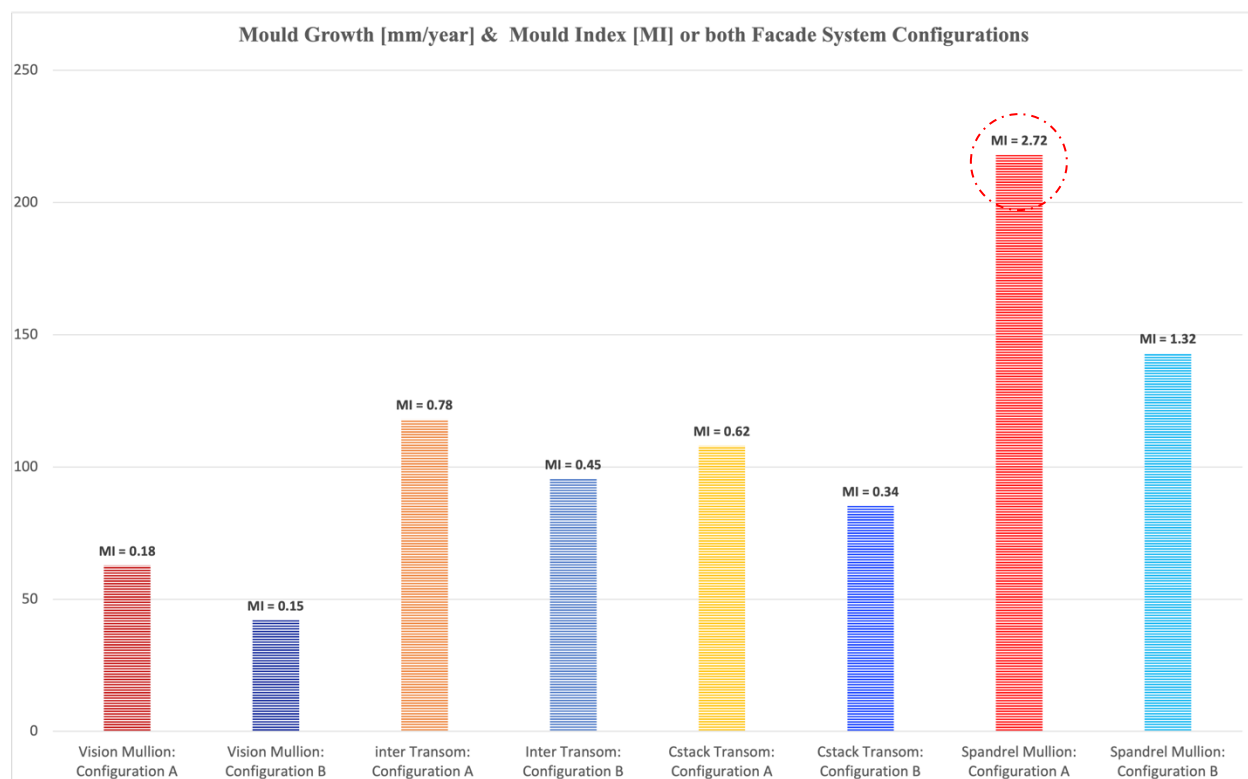

Figure 6.23: Mould Growth Development & Mould Index [MI] for both façade configurations by Wufi Bio

6.4.6. Recommendations

The results of the hygrothermal assessment offer significant insights into the behaviour of the timber frame, particularly when situated in Brussels' specific climatic conditions and when exposed to a stainless-steel protective layer. Such analyses are crucial as they clarify the inherent qualities of oak glulam. Furthermore, they provide recommendations aimed at optimising the building envelope design and preventing biodeterioration, thus enhancing its service life.

An examination of the relative humidity to which the material is exposed emphasizes the importance of maintaining the ambient relative humidity below 70% during both the manufacturing and construction phases. Such a preventative measure is crucial in mitigating drastic fluctuations in moisture content, which could potentially induce dangerous dimensional changes. This may require the use of stand-alone or integrated dehumidifiers within the ventilation systems [Strang 2021].

In addition to relative humidity, water exposure is another factor to pay close attention to. Therefore, ensuring well-defined water management procedures during construction and installation is also imperative.

Protective measures like sealing all oak glulam mullion and transom end-grains prior to reaching the construction site, prompt removal of water pooling, and tenting construction methodologies are advisable.

Assessing the moisture content from both façade system configurations revealed that while standard timber averaged approximately 12%, its counterpart which was protected with a stainless-steel sheet is at roughly 13%. This small difference can be attributed to the steel's impermeable nature, which prohibits moisture diffusion. In addition, the moisture trajectory exhibited a consistent decrease in moisture as the timber stabilises throughout the simulation on both configurations. Given this behaviour coupled with oak glulam's inherent properties of slow heat conduction and vapour diffusion, the introduction of a high vapour resistance barrier on the façade system's inner side is beneficial. Such an addition would significantly decrease vapour migration, especially from warmer to cooler areas, where condensation risk surges during colder months.

Another important takeaway from the moisture analysis is related to the material's dimensional changes, which are induced by the cyclic changes in moisture content due to the hygroscopic nature of timber. After reviewing both configurations, the stainless-steel sheet decreases the expansion and contraction behaviour of the material when compared to the standard timber frame. However, the differences between the two configurations remain small in both scenarios and both configurations, a slotted connection is needed for attaching the toggle system to the timber frame to accommodate the dimensional changes of the material.

For the standard timber frame, specifically Configuration B, the radial shrinkage in the timber mullion averaged at approximately 0.7 mm and tangential shrinkage around 1.6 mm. For the transoms, the respective values stood at roughly 0.55 mm and 1.10 mm. Factoring in these measurements, a general rule suggests employing a slotted stainless-steel connection with a movement restriction of approximately 2mm, which accounts for a hole diameter surpassing the fasteners by 2mm. This recommendation, however, necessitates further research, specifically addressing the structural behaviour of the timber and loads that the system is subjected to.

Regarding fastening materials, given the unique properties of oak glulam, the utilization of stainless-steel countersunk head screws A4 is recommended, especially due to their ease of insertion, improved holding capability, and non-protrusive heads, preserving the integrity of the material and reducing potential thermal elongation-induced fixing defects. Moreover, the class C5 resistance to corrosivity and acid resistance, plus its application in industrial and coastal areas with high humidity, make the stainless steel A4 screws an appropriate choice [Swedish Wood 2023]. The type of adhesive used in glulam, which could be corrosive to fixings, coupled with the climatic conditions calls for the use of resistant screws. The density of oak glulam, combined with its slow vapour diffusion, deserves special attention mostly when employing highly conductive connectors penetrating the timber. Such connectors can induce condensation and corrosion, further highlighting the need for moisture-resistant alloys like stainless steel.

Lastly, condensation and mould proliferation analysis for both configurations highlighted the spandrel mullion's vulnerability to condensation and mould, particularly when shielded with a stainless-steel layer. The interaction of façade components with the timber in the spandrel section increases moisture transport, compounded by limited ventilation increases the timber's susceptibility to biodeterioration. However, the elimination of the protective layer diminishes mould development risk by a significant 34% since vapour can be released from the timber without any blockages. Therefore, it is important to note that the hygroscopic nature of the timber needs to be properly understood for informed design decisions. The material's breathability emerges as a critical aspect of the analysis, advocating for moisture-open design strategies in timber envelope design, and enhancing efficient drying [Strang 2021]. It's important to underline that the findings are case-specific since there are a vast number of wood species and engineered timber variants, each with distinct mechanical and physical attributes, which make them exhibit diverse responses under similar climatic and design settings.

6.5. Analysis of Spandrel Materials

6.5.1. Methodology

Four different spandrel typologies have been selected for a hygrothermal analysis. The central aim of this analysis is to explore the direct and indirect impacts of insulation and weather-resistive barriers on these spandrel assemblies. This examination seeks to resolve the hygrothermal dynamics of each spandrel typology, providing insights into their individual performances when subjected to temperate coastal conditions over a span of three years. The objective is to identify the most suitable spandrel configuration, therefore supporting the bio-based façade system proposal.

Starting with the analysis, the effects of insulation on the assembly are studied, focusing primarily on potential mould growth, moisture content, and condensation. This analysis is important in preventing material deterioration. Further into the insulation materials, two were chosen for this study. Firstly, there is insulation derived from cellulose fibres, a sustainable solution that emerged from the recycling of newspapers. This insulation is composed of coarsely cellulose fibres blended with mineral salts [Isocell 2023]. Secondly, mycelium insulation, an organic product made from the root structures of mushrooms, grown on both organic and synthetic substrates [Biohm 2023] is used for this simulation. The selection for these materials was based on three important criteria: their optimal acoustic insulation capacity, adherence to fire safety standards, and low thermal conductivity.

The other subject of the analysis studies the effects of weather-resistive barriers. Two primary barriers, distinguished by their contrasted vapour diffusion resistance factors, are evaluated. Specifically, Traspir 150 breathable membrane with a vapour resistive factor of 18, while Vapour In 120 is 30,560. It is usually not advised to use low permeability membranes on external façade sections, primarily due to the potential threat of moisture retention. However, this study focuses on the differences in using membranes with varying vapour resistance factors and their effects on the façade system.

To facilitate the analysis, the spandrel has been compartmentalized into five analysis zones. Of these, Zones 1 & 2, positioned strategically on the insulation edges, will be the area of our focus. This is attributed to their immediate proximity to the insulation and their direct susceptibility to the weather-resistive barriers, making their analysis crucial in drawing comprehensive conclusions.

6.5.2. Schematic

In the following figure, two of the cross-sections are presented: the consecutive-stack transom and the spandrel mullion to show the positioning of both the weather-resistive barriers and the insulation materials within these models. A list of the materials used in this simulation and their properties, supported by the Wufi 2D Motion Database is presented below as well as a detailed material assembly for the different assembly configurations.

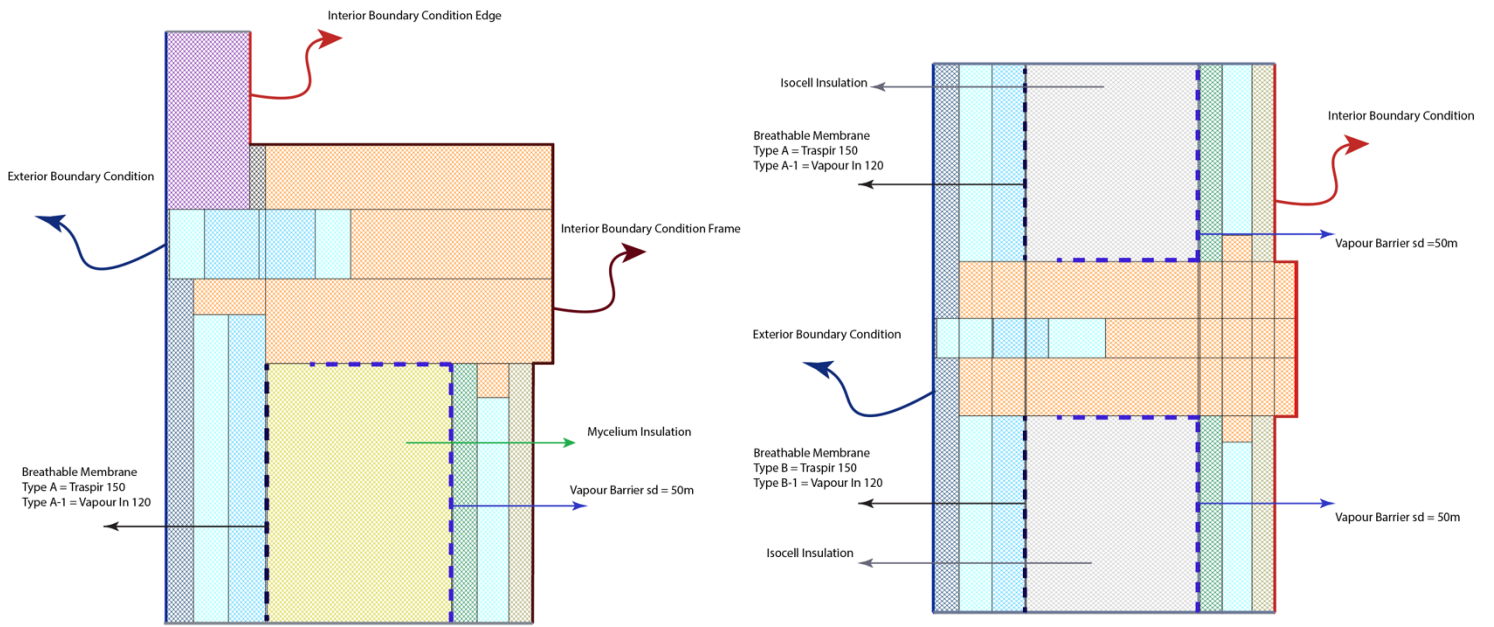

Figure 6.24: Cross-Section's schematic simulated in Wufi 2D Motion.

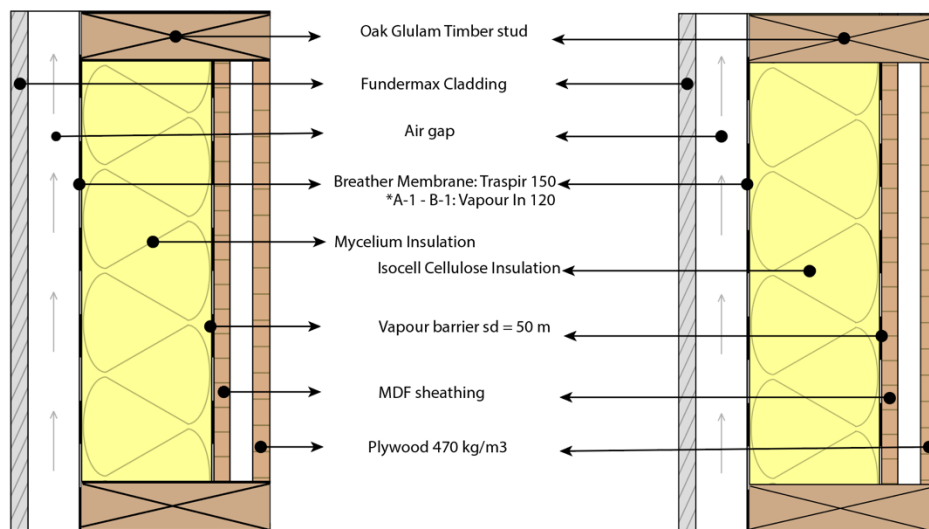

Figure 6.25: Schematic of spandrel configurations.

Materials	Bulk Density [kg/m ³]	Porosity [m ³ /m ³]	Spec.Heat Capacity [J/kgK]	Thermal Conductivity [W/mK]	Water Vapour Diffusion Resistance Factor [-]
Fundermax Cladding	1350	0.00001	1000	0.3	17200
Breather Membrane: Traspir 150	150	0.001	2300	2.3	18
Vapour retarder: Vapour 120	150	0.001	2300	2.3	30560
Mycelium Insulation	80	0.9	1020	0.04	48
Isocell Insulation	50	0.95	2110	0.037	1.8
Vapour barrier sd = 50m	130	0.001	2300	2.3	50000
MDF sheathing	736	0.62	1500	0.118	29.1
Plywood	470	0.69	1880	0.084	1078.2

Table 22: Material properties of spandrel typologies provided by Wufi Database & technical specs from manufacturers.

6.5.3. Impact of Insulation & Weather Resistive Barriers

- Insulation Behaviour under the influence of breathable membrane: Traspir150

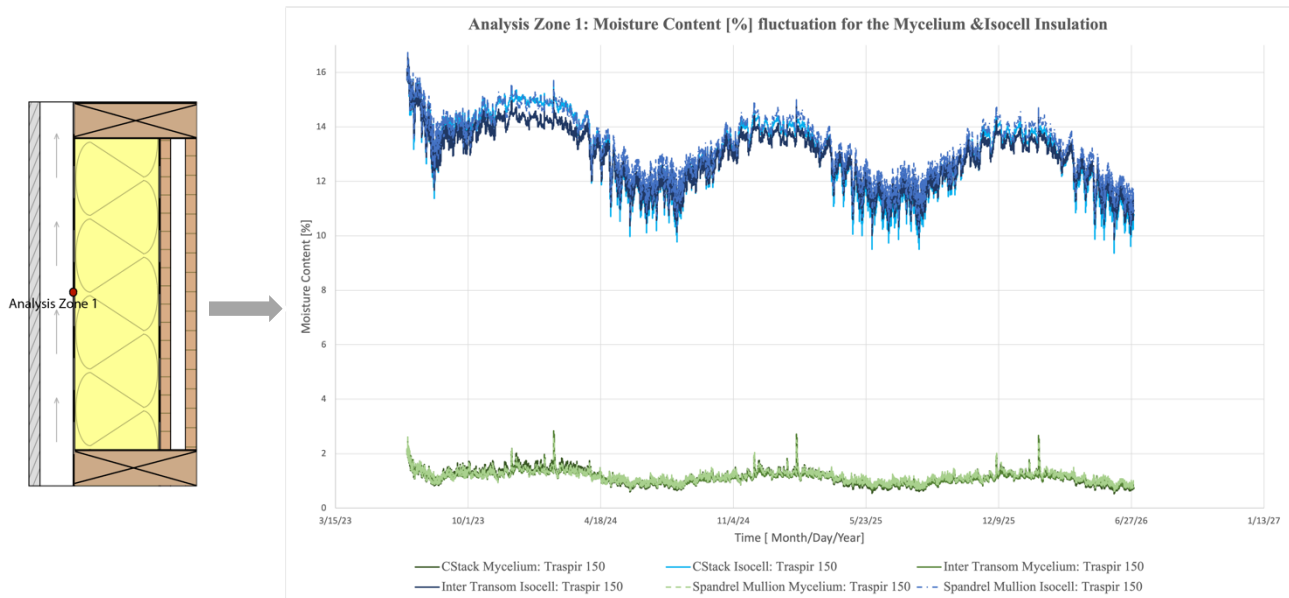

Figure 6.26: Moisture Content [%] comparison of Mycelium & Isocell insulation under the effect of breathable membrane. Wufi 2D Motion

From the evaluation of the insulation materials' distinct properties, a marked difference in moisture content is evident between Mycelium and Isocell insulations. Mycelium insulation has a notably lower moisture content, due to its higher vapour diffusion resistance factor of 48, in contrast to Isocell's 1.8. Furthermore, Isocell's lower density, when compared with Mycelium's, suggests an enhanced propensity for vapour absorption, a consequence of the increased void spaces within its structure. This results in Isocell having a higher vapour absorption capacity in contrast to Mycelium, which benefits from a denser structure that provides a higher resistance to vapour transport.

The simulations for both insulations incorporated the use of Traspir 150—a breathable membrane—as an external protective layer adhered to the insulation. The membrane consists of a polypropylene microporous elastomer film, which optimises airtightness [Rothoblaas 2023]. It manages water ingress while allowing vapour to escape from the assembly's interior, therefore enabling breathability in the assembly.

After reviewing the trajectory of moisture content for both materials, it can be observed its cyclical changes, which resemble the materials' responses to varying climatic conditions. The observed moisture content trends for both insulations mark a consistent cyclical pattern: an increase during winter months due to higher relative humidity and a decrease in warmer periods. Importantly, these trends exhibit no evidence of prolonged vapour retention within the materials, as indicated by the absence of an increasing moisture content pattern. Contrarily, a subtle descending trend is evident in the trajectories. This behaviour supports the notion that the materials possess an inherent ability to release moisture, due to the breathability access of the assembly.

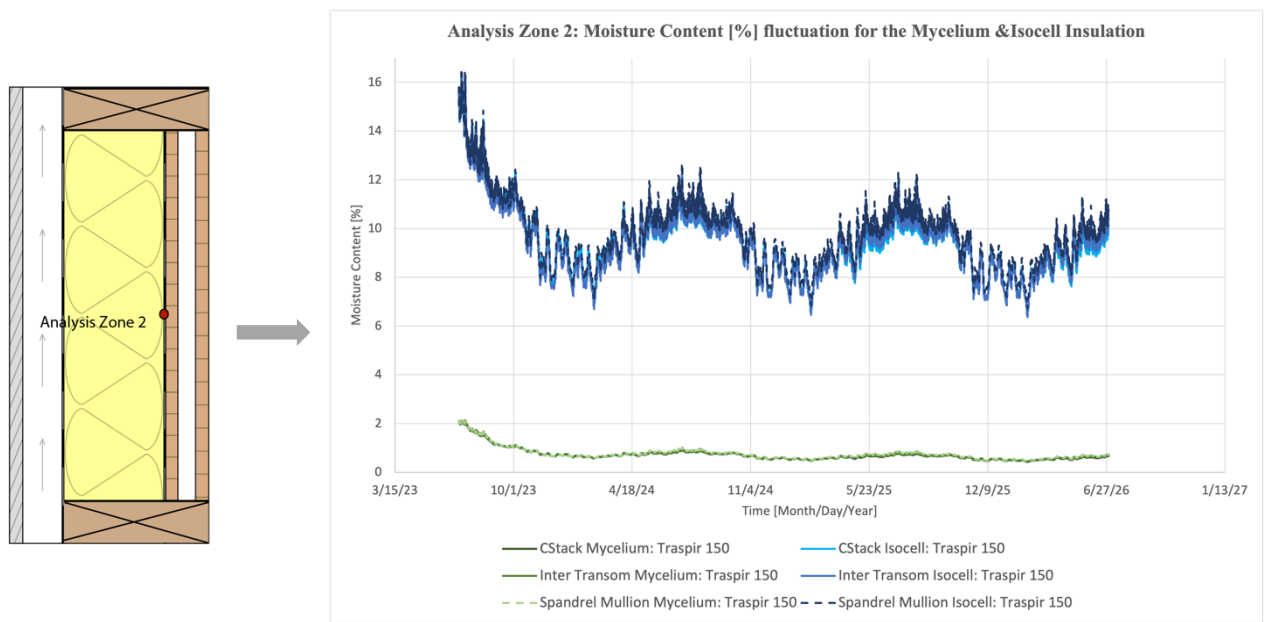

Figure 6.27: Moisture Content [%] comparison of Mycelium & Isocell insulation under the effect of breathable membrane. Wufi 2D Motion

Upon the examination of analysis zone two, the Isocell—loose cellulose insulation—exhibits a consistent cyclic moisture fluctuation throughout the simulation period. In contrast, the mycelium insulation demonstrates a diminished amplitude in its cyclic variations, trending towards a more stable moisture content profile. This behaviour is influenced by the integration of the vapour barrier situated between the MDF sheathing and the insulation layer. The synergy between the vapour barrier's pronounced resistance capabilities and the mycelium's inherent property to slow vapour diffusion results in a controlled vapour environment. Such an environment is beneficial for the optimal performance of the mycelium insulation. However, the high permeability of the Isocell insulation diminishes the efficacy of the vapour barrier due to the material's high moisture diffusion rates.

- Insulation behaviour under the influence of vapour control barrier: Vapour IN 120

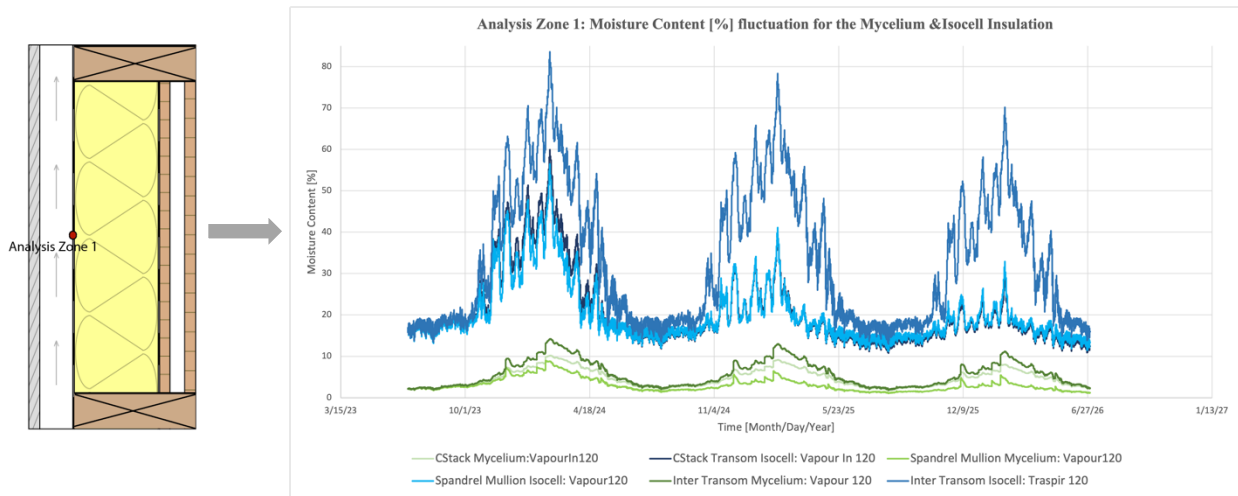

Figure 6.28: Moisture Content [%] comparison of Mycelium & Isocell insulation under the effect of breathable membrane. Wufi 2D Motion

Introducing a vapour control membrane with a high vapour resistance factor in the exterior of the building envelope significantly impacts the moisture content of the outer insulation. This effect is observed irrespective of the insulation type, with a noticeable increase in moisture content. Notably, the loose cellulose insulation presents a severe contrast in moisture content when exposed to the vapour control barrier. While there is a general decline in the cyclic moisture trend, its peak exceeds 80%, raising concerns regarding biodeterioration within the insulation.

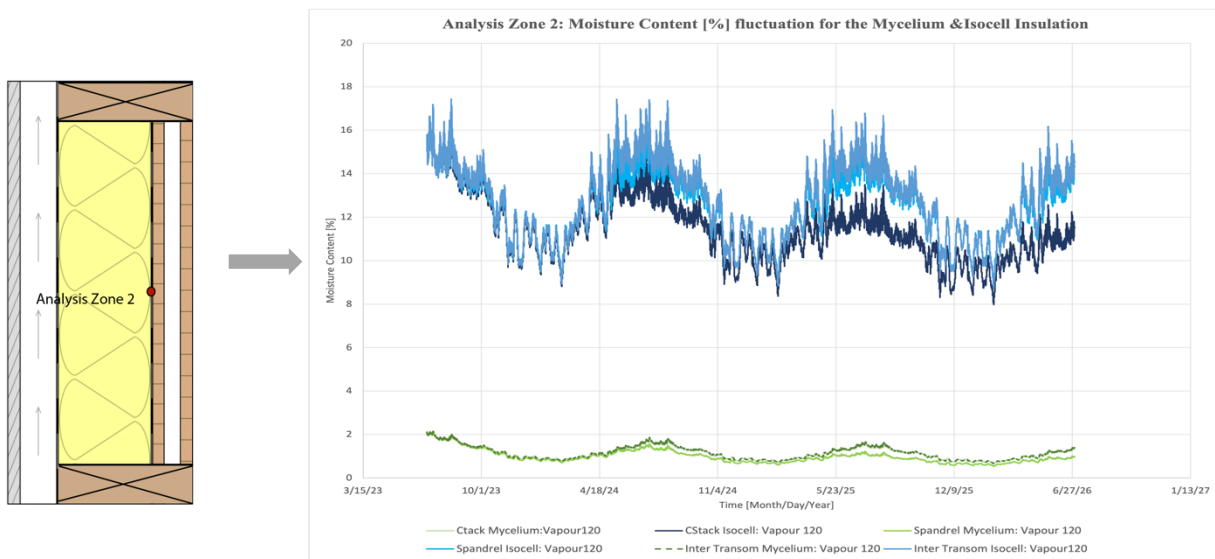
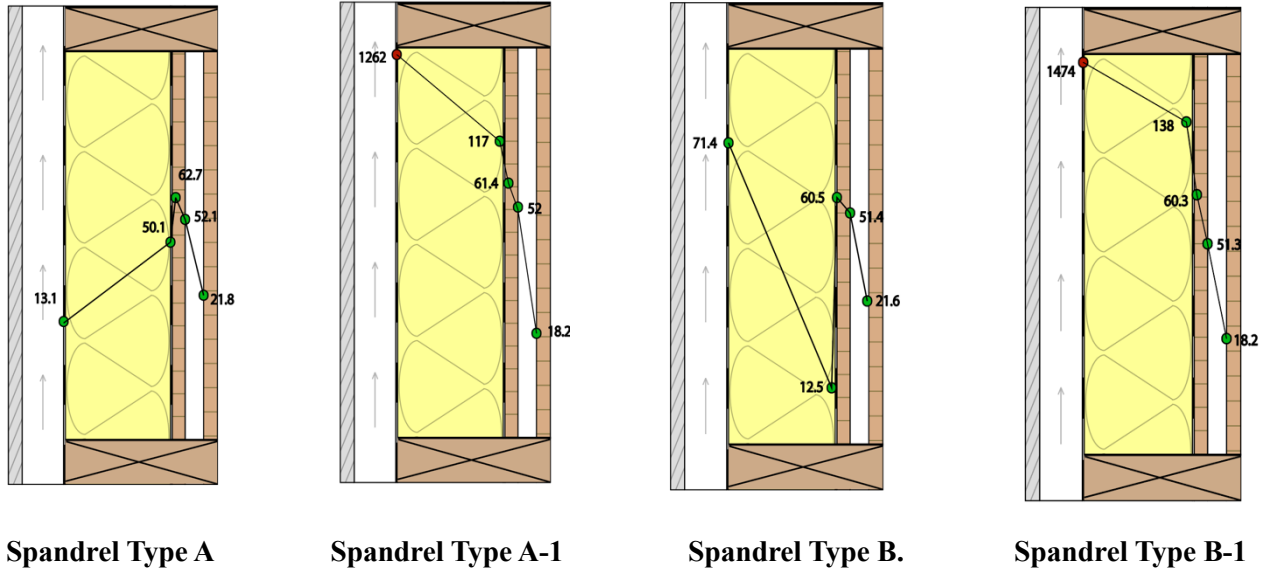

Figure 6.29: Moisture Content [%] comparison of Mycelium & Isocell insulation under the effect of breathable membrane. Wufi 2D Motion

Further examination of Analysis Zone 2 reveals an increased moisture content compared to the material's performance in the presence of a breathable membrane. This indicates that the excessive moisture load is concentrated on the insulation's outer edge. Even though, the impact of this concentration is not perceived at this location. The introduction of the vapour control membrane has had a profound detrimental effect on the wall assembly. Material decay, even if localised, poses a significant threat to the structural integrity of the system.

6.5.4. Mould Growth Assessment



Traffic Light	Level of Risk	Mould Index (MI) ASHRAE 160 Limit	IBP Model Mould growth (mm/year)
Green	Usually, acceptable	MI < 1	Growth < 129 mm/year
Yellow	Additional investigations are needed	1 < MI < 2	129 < growth < 176
Red	Usually not acceptable	MI > 2	Growth > 176 mm/year

Table 23: Analysis Scale set by Wufi Bio according to ASHRAE.

The four distinct spandrel configurations underwent a mould growth analysis utilising the Wufi Bio plugin for the Wufi software. To maintain consistency with the timber frame assessment, the substrate class was designated as Class 0. This classification represents the maximum potential mould growth encountered in buildings. [Wufi Bio 2015]

Preliminary results show an overall reduction in mould growth when utilising mycelium insulation in contrast to its Isocell counterpart. The difference is attributed to mycelium's higher vapour resistance capabilities, which reduces vapour diffusion within its matrix.

Furthermore, the role of weather-resistive barriers, specifically in modulating mould growth, was made very clear throughout the analysis. The strategic integration of a breathable membrane on the external side

of the assembly facilitates optimal ventilation. Since adequate aeration substantially reduces risks associated with biodeterioration of materials.

Looking into specific scenarios such as Type A-1 and B-1, both of which incorporate a low-permeability layer on the exterior, results become a concern. Potential mould growth rates of 1262 mm/year for mycelium and a slightly elevated 1474 mm/year for loose cellulose were recorded. Such results indicate the failure of the system, accentuating the importance of proper ventilation in diminishing mould proliferation and preserving the structural integrity of the system.

6.6. Recommendations

The principle of breathability in the building envelope is crucial and extra caution needs to be taken when adhering the breathable membrane to the insulation due to the difficulty of addressing exposure to rain leakage once it occurs. This clarifies the importance of the cladding's design; it must serve as the foremost barrier against rain, thereby preventing any driving rain from reaching the air cavity that the breathable membrane is exposed to. Such design intricacies underline the significance of stringent water protection measures during both the construction and assembly phases to ascertain a watertight envelope. This highlights the importance of water protection measures during construction and assembly to guarantee a watertight façade system.

Emphasizing the procedures to follow, securing an effective seal on weather-resistive barriers is important to preventing potential future leakages. It is recommended to employ taped seams, specifically along the membrane's edges, as a method to sustain airtightness. [Strang's 2021]

Furthermore, discerning the proper positioning of weather-resistant membranes, which varies based on climatic conditions, is of paramount importance for maintaining the building envelope's functional integrity.

Membranes with high vapour resistance factors are most effective when situated in the façade assembly's warmer zones, providing a crucial safeguard against moisture entering the indoor environment. When these membranes are paired with materials characterized by slow vapour diffusion and low vapour permeability, create a controlled vapour environment which becomes especially significant with the inclusion of bio-based materials in the facade assembly. These materials, given their inherent characteristics, often display high sensitivity to moisture fluctuations, accentuating the risk of mould growth.

6.7. Conclusions

This chapter investigates a detailed hygrothermal study regarding the behaviour of a bio-based building envelope located in Brussels. The primary focus of the initial section is on understanding the behaviour of the oak glulam frame and determining the effectiveness of stainless-steel sheathing as a protective barrier. A comparative analysis was undertaken to examine Configuration A, which incorporates a timber frame with the protective layer, against Configuration B, the standard frame. The aim was to assess variables such as moisture content, potential for condensation, mould risk, and dimensional changes. It was important to analyse the necessity of the stainless-steel protective layer or to determine if the timber frame could independently be exposed to natural climatic variations.

Initial conditions were set to measure the drying capacity of the frame and its proficiency in stabilising in relation to the ambient air. Upon further evaluation, it was evident that the stainless-steel protective layer did indeed influence the timber's moisture content, causing an average increase of 1% in comparison to the standard frame. This can be attributed to the steel's impermeable characteristics, which reduce vapour migration through the material. Notably, even a slight increase in moisture content can have other implications, especially if the moisture can't be released.

Consequently, the timber with the protective layer exhibited a high propensity for condensation and potential mould development compared to its counterpart, Configuration B. However, in terms of dimensional stability, the protected timber exhibited marginally better results, though the differences were minimal.

After analysing the results from Configuration B, and reviewing the specific properties of oak glulam, revealed the material's optimal stability under climatic variations, due to its high density and slower moisture diffusion rate. This ensures a more gradual stabilization process, protecting it from any significant dimensional alterations that might compromise its mechanical properties.

Another important parameter to include in the analysis to accurately assess the impact of the stainless-steel protective sheet against the standard timber framing is the maximum acceptable moisture content that the timber can safely be exposed to. As previously explained, timber is constantly interacting with the surrounding ambient air by absorbing and releasing moisture. However, excessive moisture content can severely damage the material and cause biological decay. The moisture content threshold is dependent on the wood species, thus for the case of European oak, a moisture content below 20% and a relative humidity below 90 % is not considered to be at risk from fungal decay. However, surface mould growth and staining can occur at 18 % moisture content under certain conditions. [Trada 2011]

Oak, specifically because of its compactness has fewer voids in its matrix, making it less susceptible to moisture retention, therefore it is more durable against biotic decay.

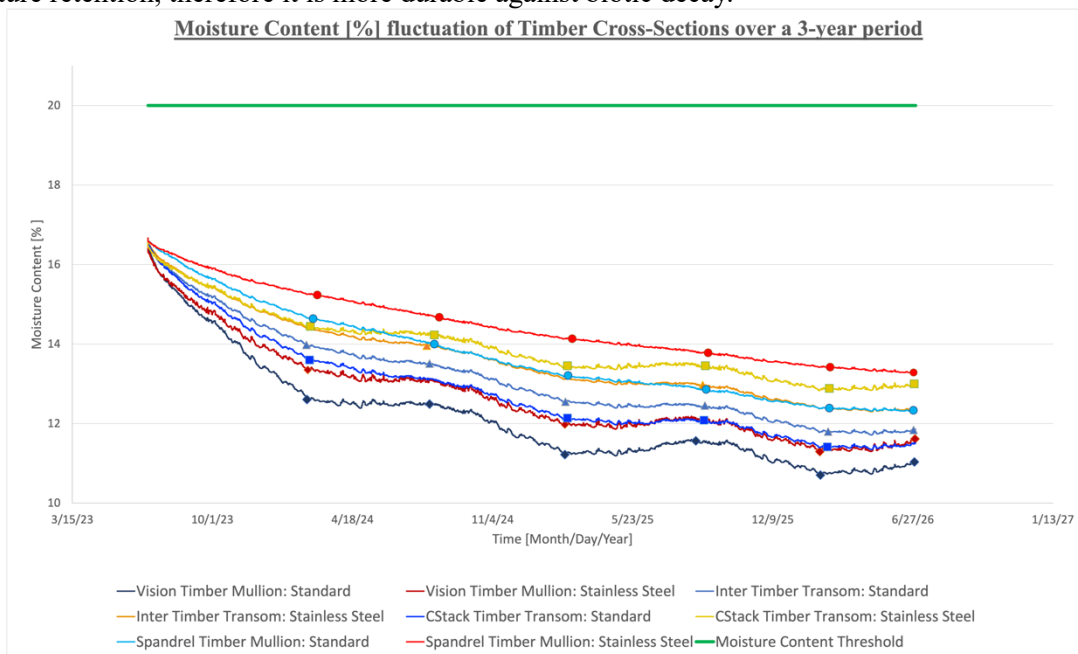

Figure 6.30: Moisture fluctuations of Configuration A & B against maximum acceptable moisture content for European oak.

Reviewing the results, the maximum moisture content for both scenarios is ~ 16 % at the beginning of the simulation and the average moisture content for configuration A is ~ 13 % while configuration B is ~ 12 %, way below the 20 % mark. Such results indicate that the timber frame is safe from fungal decay under exposed climatic conditions and both configurations.

However, it's important to highlight that the behaviour manifested by oak glulam in this study is predominantly characteristic of coastal temperate climates. In addition, the findings emphasise the importance of ventilation and breathability for bio-based materials. Regarding installation practices to

attach the toggle system to the timber, further analysis needs to be made to properly assess connection design and procedures to account for the system's structural dynamics.

Analysing the results of the spandrel typology, mycelium insulation exhibited better stability, with its moisture fluctuations being significantly diffused compared to the loose cellulose insulation. Mycelium's inherent rigidity ensures ease in dismantling, becoming more adaptable for maintenance and potential building envelope reconfigurations, unlike the challenges caused by the blown-in application of loose cellulose. Furthermore, investigating weather-resistive membranes, the integration of a breathable membrane on the exterior of the system becomes essential for promoting vapour diffusion and facilitating the release of vapour from materials.

Moreover, it can be concluded that the stainless-steel sheet in configuration A, regardless of its impact on moisture retention and potential increase in mould risk development, does not cause biological decay. This is because the average relative humidity of the system is approximately 35 % less than the moisture allowable threshold. Thus, for the climatic conditions of the city of Brussels and the specific design characteristics of the preliminary design concept, both configurations can optimally be introduced.

However, it is also not needed, the properties of the material such as, its slow moisture diffusion, and optimal stability contribute to the material's capability to withstand coastal weather conditions without compromising its structural integrity.

Also, from a sustainability perspective, it is important to further reduce the reliance on non-renewable materials mostly when is not necessary, thus it can be decided that configuration B, which involves the timber frame and the gasket system as the main protective layer mechanism is the most optimal choice to add to the design concept.

Finally, one of the main points of this analysis is the importance of allowing the biobased construction materials the freedom to interact with the surrounding air while safeguarding them against water infiltration. While achieving this equilibrium may pose challenges, the comprehension of their hygrothermal behaviour and ensuring the design proposal considers such behaviour is key to guaranteeing that bio-based materials can function as efficiently as conventional construction materials.



7. **FINAL DESIGN**

The optimized bio-based design system is presented in this chapter based on the performance assessment conducted in the previous chapter. On the analysis, the durability of the system was overviewed under natural environmental conditions to optimize the system accordingly. The cross-sections, detail connections and final dimensions are included in the proposed design details.

7. Final Design

After analysing the thermal and hygrothermal behaviour of the bio-based cross sections, it was concluded to not implement the protective stainless-steel sheet as a protective layer. The investigation studied the impact of the stainless-steel sheet on the timber frame and the behaviour of the frame itself against the Belgium weather context. Thus, the results indicate that the timber frame alone and under the specific design features can optimally withstand the environmental conditions without jeopardizing its structural integrity.

Furthermore, the importance of breathability of the material came to light as an important design characteristic to implement when introducing bioproducts in façade design and construction. Thus, the gathered information has been used in optimizing the proposed bio-based façade system.

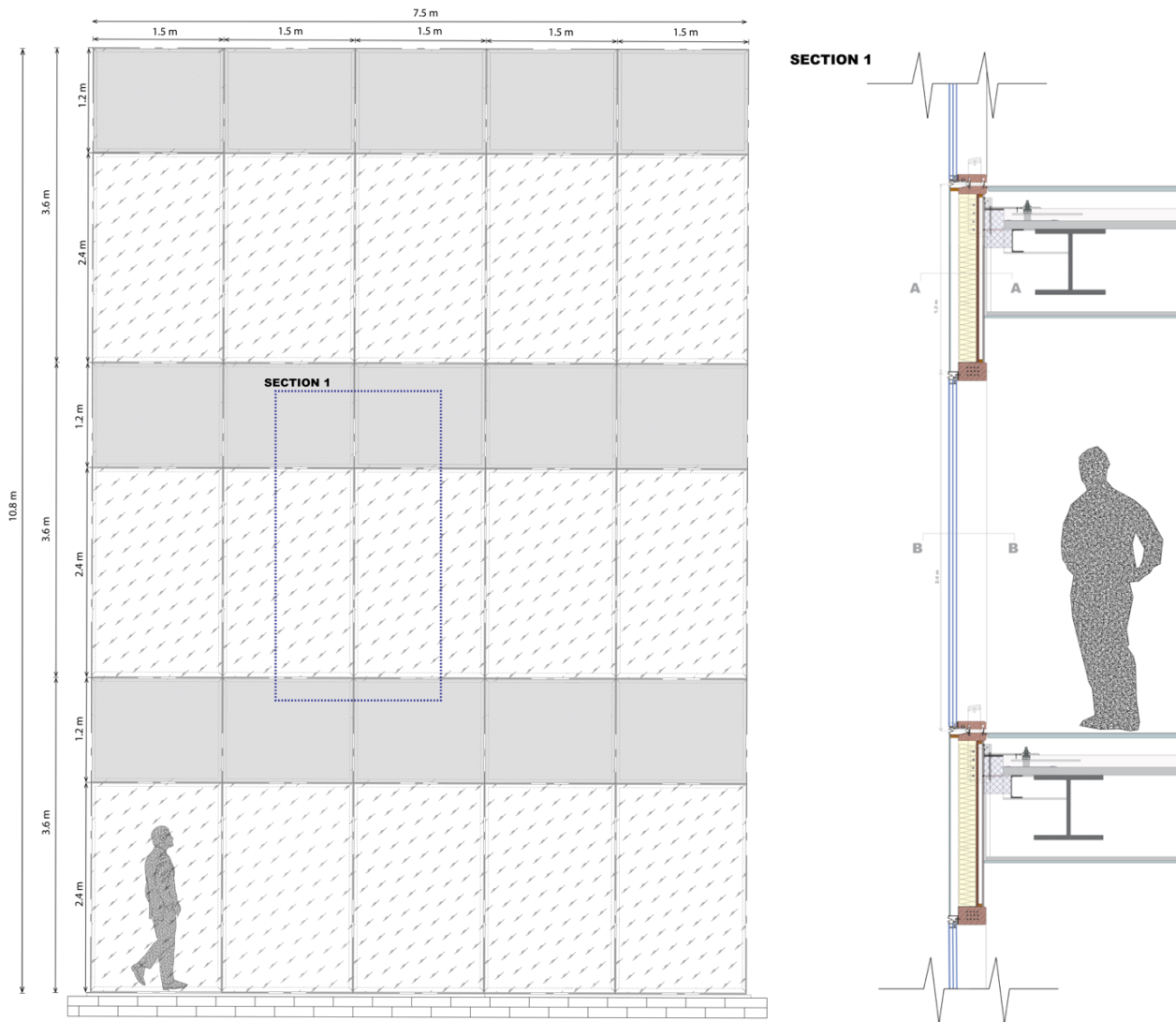

Figure 7.1: Elevation & vertical detail schematic of bio-based façade system proposal. Source: by author.

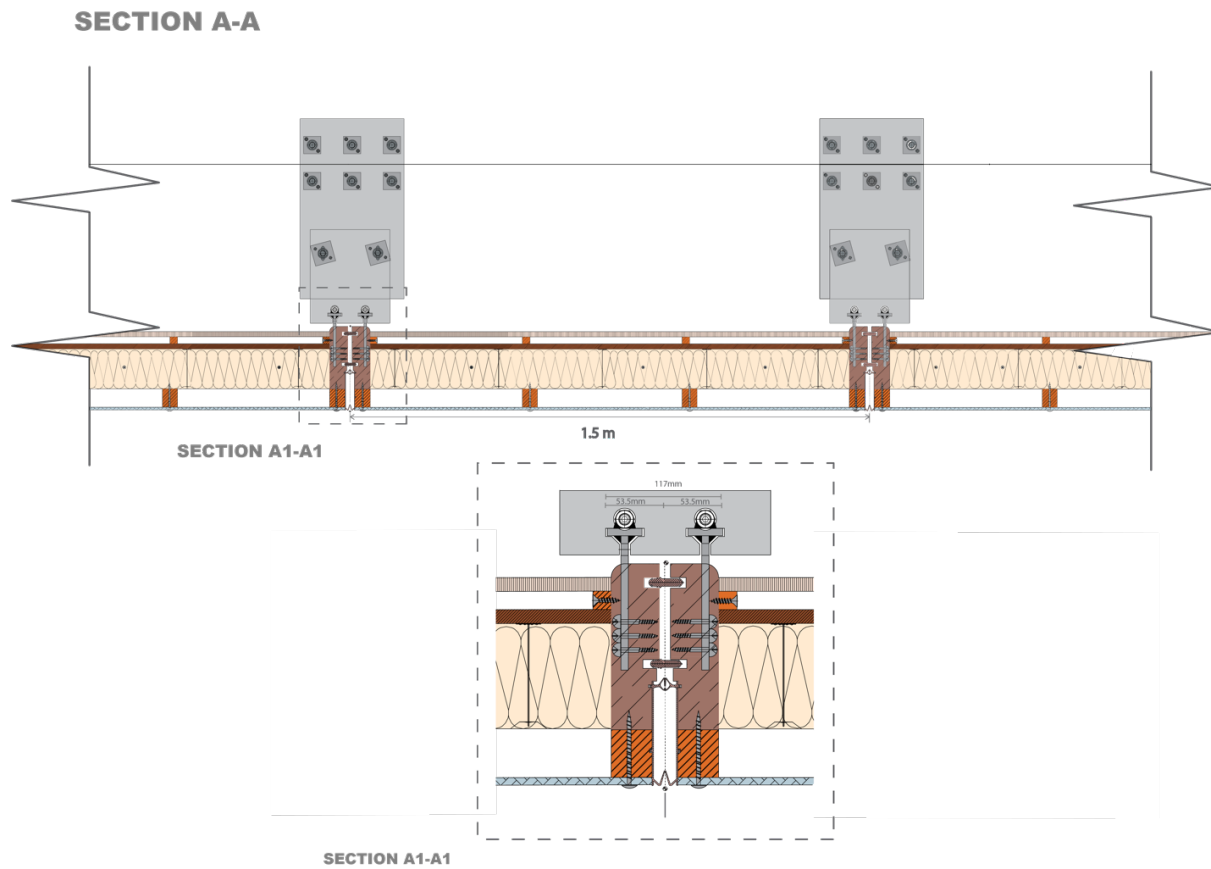

Figure 7.2: Schematic of spandrel mullion – horizontal connection. Source: by author

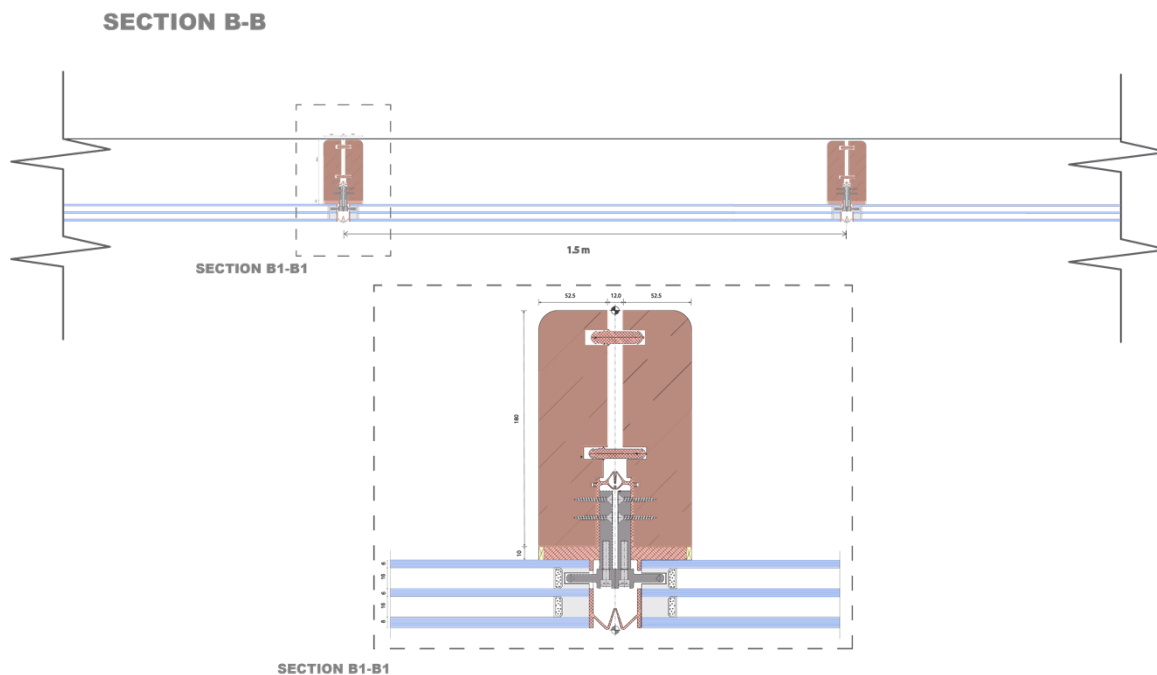

Figure 7.3: Schematic of vision mullion – horizontal connection. Source: by author



8.

LIFE CYCLE ASSESSMENT

This chapter introduces a Life Cycle Assessment of the proposed bio-based façade system against standard aluminium curtain wall facades. Special considerations are introduced due to the organic nature of the proposed materials and a cradle-to-grave methodology is implemented to overview the impact, potential benefits, and constraints of the bio-based façade throughout its whole lifespan.

8. Life Cycle Assessment

8.1. LCA – Calculation Method

In this section, the focus is directed towards the analysis of the proposed bio-based façade system from an environmental perspective. The goal is to quantify the sustainable advantages that are brought by its implementation.

To achieve this, a Life Cycle Assessment (LCA) approach is conducted. Defined as a method for measuring the environmental impact of building products, LCA accounts for both the embodied and operational impacts of these materials, in alignment with building regulations like the NEN-EN 15978, which outlines the calculation procedure.

Such calculation procedure encompasses processes and systems where the materials and products are integrated. To delimit the areas of focus of the LCA data and to accurately measure the main environmental impact of the building products and materials, a system boundary is placed. The boundary conditions are formed by life cycle stages to avoid accounting for the impact of secondary materials, by-products, or other systems. Therefore, the life cycle stages or modules are implemented as follows:

1. **Module A1 – A3 - Product Stage:** Accounts for the first step in the life cycle assessment and assesses the raw materials production, transportation, and manufacturing into a product.
2. **Module A4 – A5 – Construction Stage:** After the product is manufactured the construction stage starts where the product is transported to the building site and installation. This module is optional.
3. **Module B1 – B7 – Use Stage:** This stage relates to the use of the products over their entire life cycle, where maintenance, replacement, and potential repairs are accounted for. This module is optional as well.
4. **Module C1 – C4 – End of life Stage:** This phase starts as the service life of the products finalizes and focuses on the disposal, deconstruction, and demolition of the product.
5. **Module D - Environmental benefits and loads:** Accounts for the net benefits and loads coming from the reuse of products, recycling, or energy recovery from disposed products resulting from the construction, use, and end-of-life phases.

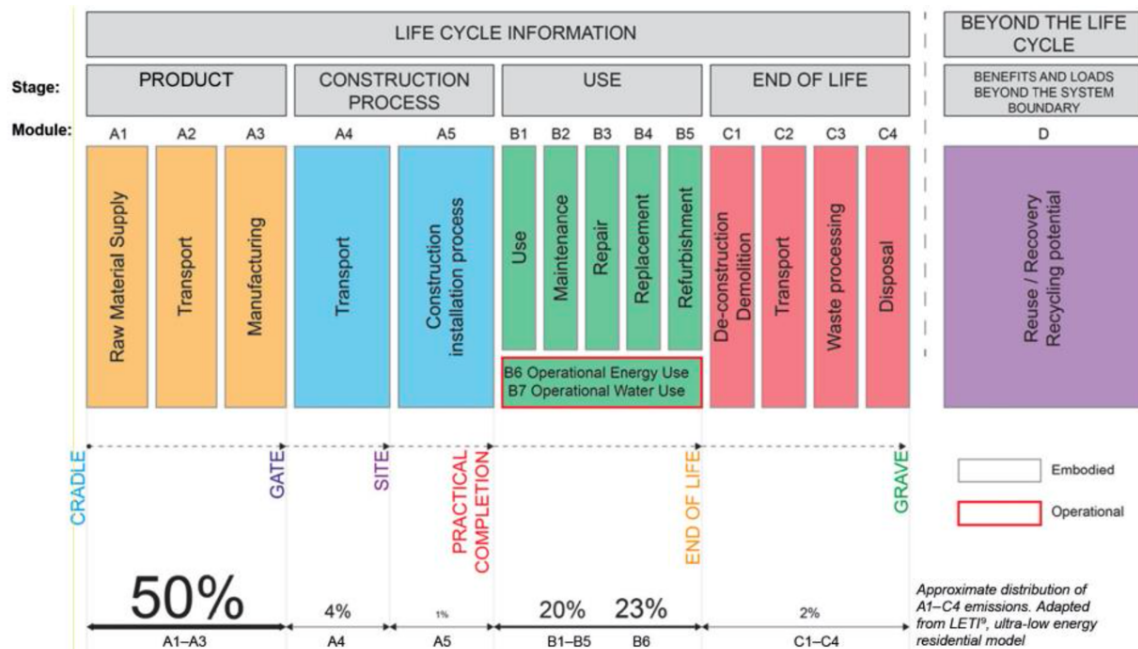

Figure 8.1: Life Cycle Assessment Stages according to BS EN 15978. IStructE, 2020

As denoted in Figure 8.1, the product state (A1-A3) is the largest contributor to the embodied carbon of a product followed by the use stage (B1-B7). However, the latter is optional and is often omitted from the boundary conditions in the life cycle. [IStructE 2020]. It is important to note that the reliability of the assessment is highly dependent on the input which is determined by the carbon factors established in the environmental declaration product (EPD) of the materials and used databases.

For this case study, the environmental impact will be conducted through the One Click LCA software, and the gathered data and material specifications are supported by the database EcoInvent and the EPDs of the materials used.

Environmental Product Declaration [EPD]

The environmental product declaration is defined as a standardized document which reports the environmental impact of a product or material. It is performed by the manufacturers of the product, and it is based on the ISO 14025 standard which encompasses all the life cycle stages. [Ecochain 2023] Its goal is to communicate and inform the stakeholders about the product's environmental impact and it is produced based on LCA calculations and to provide a quantitative assessment for the analysis and comparison of products and services.

8.2. Bio-based material considerations

The introduction of bio-based materials into construction processes needs consideration during the environmental impact assessment. Unlike standard construction materials like aluminium and concrete, which undergo unique fabrication processes, bio-based materials such as timber have distinct production considerations. These account for various stages including seedling, harvesting, reforestation of the selected wood species, and the production processing of mass timber products as final products.

An important aspect of bio-based materials, due to the seedling phase, is their biogenic carbon content, considered as carbon storage. This analysis takes into account the carbon dioxide captured from the atmosphere during photosynthesis and retained within the bio-based material throughout its lifespan.

Regarding the material selection for this analysis, an examination of various factors including the place of origin, market availability, and transportation means of the raw material to the factory are reviewed. In this particular case study, all materials have been sourced within the Netherlands and Europe, ensuring a degree of consistency and reliability in the assessment.

Within the scope of the analysis, module D related to elements beyond the system boundary is not considered, due to the absence of sufficient information regarding the end-of-life allocation of certain bio-based materials, such as mycelium insulation. Therefore, the focus of the assessment centres on the cradle-to-grave analysis.

8.3. Scope of the analysis

In this study, the adopted methodology is rooted in a comparative analysis aimed at highlighting the environmental advantages of integrating curtain wall façade systems with no reliance on aluminium in their composition. Thus, the aluminium curtain wall system is measured against the proposed bio-based design concept. The life cycle assessment focuses on describing the specific recovery scenarios for each material type, encompassing aspects of recyclability, reusability, and landfill disposal percentages.

The comparative analysis is structured based on three distinct scenarios,

- Scenario 1 is characterized by the conventional aluminium curtain wall system.
Aluminium Profiles: 94 % recycling, 3% landfill, 3% incineration.
- Scenario 2 introduces the preliminary bio-based design concept, centring on the incineration of materials at their end of life.
Timber Frame & Bio-based spandrel: 85 % incineration, 5% recycling, 10% landfill.
- Scenario 3 places emphasis on the reusability of materials at the end of the life of the bio-based design system.
Timber Frame & Bio-based spandrel: 80 % reuse, 20% incineration.

The analysis of the three scenarios is essential in pointing out the potential environmental benefits of applying circularity into the end-of-life of curtain wall façade systems, which already have implemented sustainable practices in the material and design level against standard curtain wall systems currently implemented in the market.

Consequently, the environmental impact assessment of the three scenarios will be analysed for five principal categories relevant to the use of bio-based materials: Global Warming Potential (GWP) total, fossil, biogenic, Land-Use Change (LULUC), and water usage (m³).

8.4. Functional Unit

The functional unit used for the analysis of the three scenarios is 1m^2 . The systems share the same façade typology, unitised curtain wall, and the same dimensions as shown in the figure below. The aluminium curtain wall system weighs 321.37 kg , while the proposed bio-based façade system weighs, 378.48 kg . The dimensions of an individual facade unit for the two façade systems are $1500\text{ mm} \times 3600\text{ mm}$.

The aluminium curtain wall façade element and bio-based design concept consist of:

Aluminium Curtain Wall:

- TGU [mm] – 8-16-6-16-6
- Spandrel: IGU, mineral wool, galvanized steel sheet
- Aluminium profiles
- Aluminium extrusions
- Gasket, silicone, fasteners
- Aluminium anchor slides
- Aluminium anchor plates

Bio-based Façade System:

- TGU [mm] – 8-16-6-16-6
- Spandrel: mycelium insulation, MDF sheathing, plywood board, softwood sub-frame
- Glulam frame
- Gasket, silicone, fasteners
- Aluminium anchor slides
- Stainless steel toggle connection
- Aluminium anchor plates

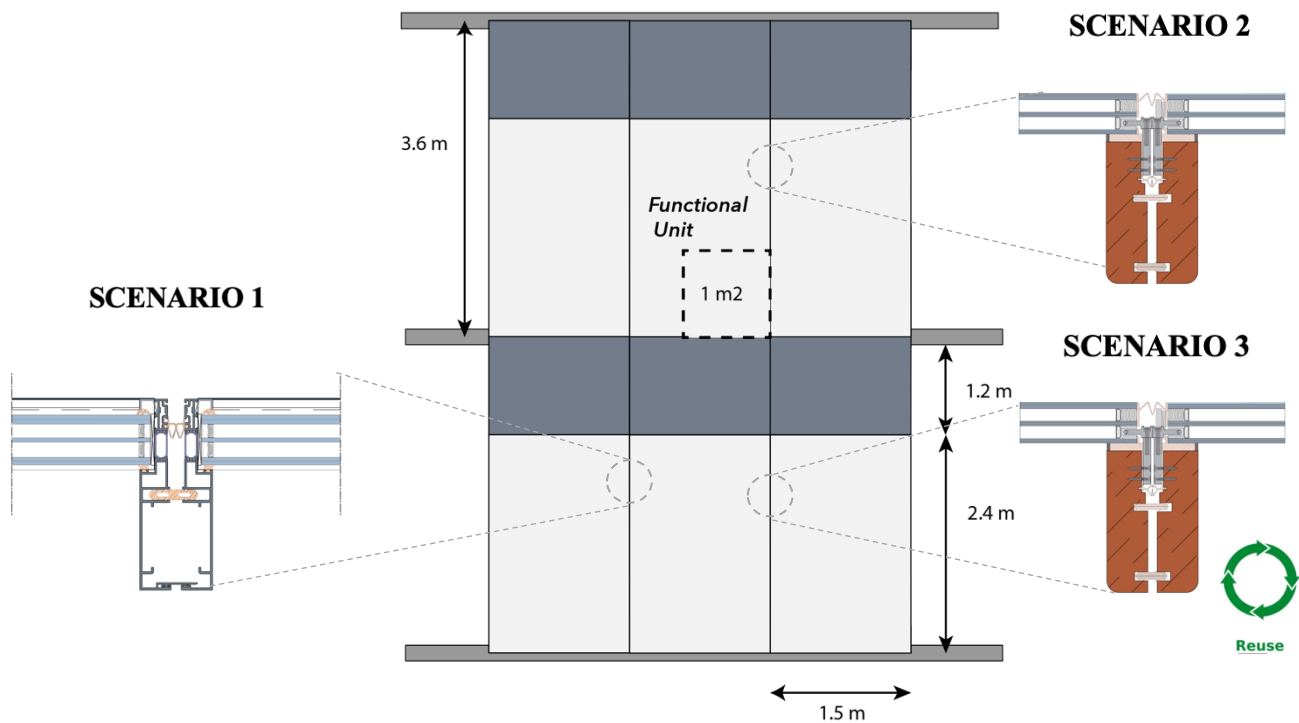

Figure 8.2: Functional Unit and mullion schematic for the three scenarios, Source: by author

8.5. System Production Description & Construction Process

Module A1 – A3: Cradle-to-Gate

The production and sourcing of the materials has been determined to stay within the Netherlands and European countries. The transportation is established to the city of Amsterdam.

A1 – Raw Material Supply

- *Aluminium CW Façade System [Scenario 1]*

The production of the aluminium profiles begins with the supply of the raw material. This stage includes the raw material extraction and processing along with the processing of secondary materials. The aluminium billets for the profile production consist of 50% primary and 50 % recycled. [Etem International]

For the mineral wool insulation applied in the spandrel of the system, the raw material comes as recycled stone wool, which enters the product system as waste. Recycled fuels are also used for its production.

- *Bio-based CW Façade System [Scenario 2 & 3]*

Carbon storage from wood and mycelium growth is accounted for in this stage. However, carbon emissions are considered from the processing and transportation of raw materials to the creation of the final product, since to create the engineered wood product, processes such as cutting, glue, hardener and preservative agent production are needed. For the case of mycelium insulation, processes such as drying, planning, and packing are applied, and carbon emissions are considered.

Production, transport of materials for packaging, and electricity production and distribution are also included in this phase.

A2 – A3 – Transportation & Manufacturing

- *Aluminium CW Façade System [Scenario 1]*

Starting with the aluminium profiles, if the raw materials are not locally sourced, they are transported from different countries in Europe. The manufacturing processes part of the production of aluminium include extrusion, cutting, and thermal breaking for thermal break manufacturing, and packaging.

Accounting for the mineral wool insulation, the transportation to the factory is considered. For the creation of the insulation product, the raw materials are heated to then spun to form a mass of fine intertwined fibres, which are followed by the curing, cutting, finishing, and packing process to finally be transported to the site.

- *Bio-Based CW Façade System [Scenario 2 & 3]*

This phase encompasses processes tied to the manufacturing stage, the majority of which are executed within the production plant. In this phase, transportation to the company gate is also accounted for.

In the context of glulam manufacturing, the lamellas are selected based on their resistance class and checked for any potential defects. Subsequently, slats are conjoined at the head to achieve the requisite lengths. Following this step, the lamellas are adhesively bonded to form an individual layer and subjected to a drying process. Post-drying, these layers are further glued together, forming the final product. The resultant beam undergoes a pressing process and is ultimately cut to the desired dimensions.

The manufacturing process for mycelium insulation starts after the growing period has ended. As seen in the figure below, the first step is to cold press it to remove moisture from the growing medium, then drying and heat pressing take place not only to eliminate any extra humidity but also to cure the material preventing any regrowth of the mycelium spawn or unwanted microorganisms. Thus, exposing the material to higher temperatures beyond 80 C, the spawn can't survive, creating a stable insulation product. [Stowa 2019]

It is important to note that the manufacturing process of the used materials was provided by the producers of the building products but for the case of mycelium insulation, the process was modelled using data from literature research.

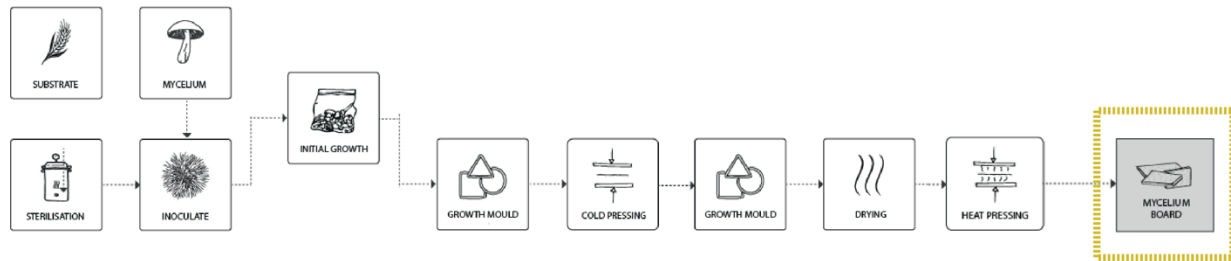

Figure 8.3: Mycelium Insulation Process Development - A1 – A3. Source: Modified by Stowa 2019

Module B: Repair, Refurbishment and Replacement

Repair, refurbishment, maintenance, and replacement for both systems are based on specifications from manufacturers and the specific features of the design concept. For both systems, the only phase considered is replacement B4.

The materials modelled on this phase for the two façade systems are the same, the only variation relies on quantities. Replacement is accounted for EPDM gaskets, where synthetic rubber production is considered. The production for glazing is also added to this phase as well as silicone production. The energy for installation, and the transportation to the site as well as the wood pallets for production are included in this life cycle stage.

Module C: End of Life

At this stage, the recyclability, landfill disposal, and incineration percentages are addressed for the materials. The life expectancy for the three curtain wall scenarios is expected to be 25 years.

C2 – Transportation to Waste Processing

The transportation of the materials to the end-of-life destination is considered in this module. The distance is set to 100 km for recycling, landfill, and incineration for the three scenarios.

C3 – Waste Processing for reuse and/or recycling

The waste processing for the three scenarios is presented below. For the bio-based façade system, the two scenarios have different emphases for the end-of-life cycle of the materials. Scenario 2 focuses on incineration as the end-of-life strategy for the materials, while scenario 3 centres on the reusability potential of the façade components.

- *Aluminium CW Façade System [Scenario 1]*

The aluminium curtain wall system follows European standards to account for the end-of-life allocation of materials. Aluminium is disposed of with 94 % for recycling, and 3 % for incineration, while the mineral wool insulation allocates 10% for recycling, and 5% for incineration. Lastly, the glazing system has a recyclability percentage of 70%.

- *Bio-based CW Façade System [Scenario 2&3]*

Both scenarios are designed to be disassembled rather than demolished. Façade components such as the cladding can be disassembled on-site. However, the glazing system may need to be dismantled at the manufacturing location, thus fossil fuel-powered machinery and transportation are used. For scenario 2, the

timber frame and bioproducts part of the spandrel are disposed of through 85 % incineration, and 5 % recycling. While scenario3 establishes the disposal of the materials through 80 % reuse and 20% incineration. The glazing system follows the same end-of-life parameters as the aluminium curtain wall system.

C4 – Disposal

This module represents final disposal, including landfill, and incineration with no energy recovery or below 60 % [One Click LCA]

- *Aluminium CW Façade System [Scenario 1]*

For this scenario, the main materials being landfilled are aluminium 3 %, thermal breaks 20%, steel 5%, glazing 30%, and mineral wool 85% which are disposed of in a sanitary and inert landfill depending on the material.

- *Bio-Based CW Façade System [Scenario 2&3]*

The bio-based materials are discarded in a sanitary landfill. In scenario 2, 10% of the timber frame and bio-based spandrel mass is landfilled while the standard materials such as glazing, and stainless steel follow the same process as the aluminium curtain wall façade. Scenario 3, due to the reusability and incineration allocation of materials, the landfilled bioproducts have significantly reduced, where the HPL cladding is the only material, whose 40 % of its mass is eliminated in a sanitary landfill at the end of its lifespan.

The following figures show the system boundaries for the aluminium and timber life cycle stages implemented in this case study.

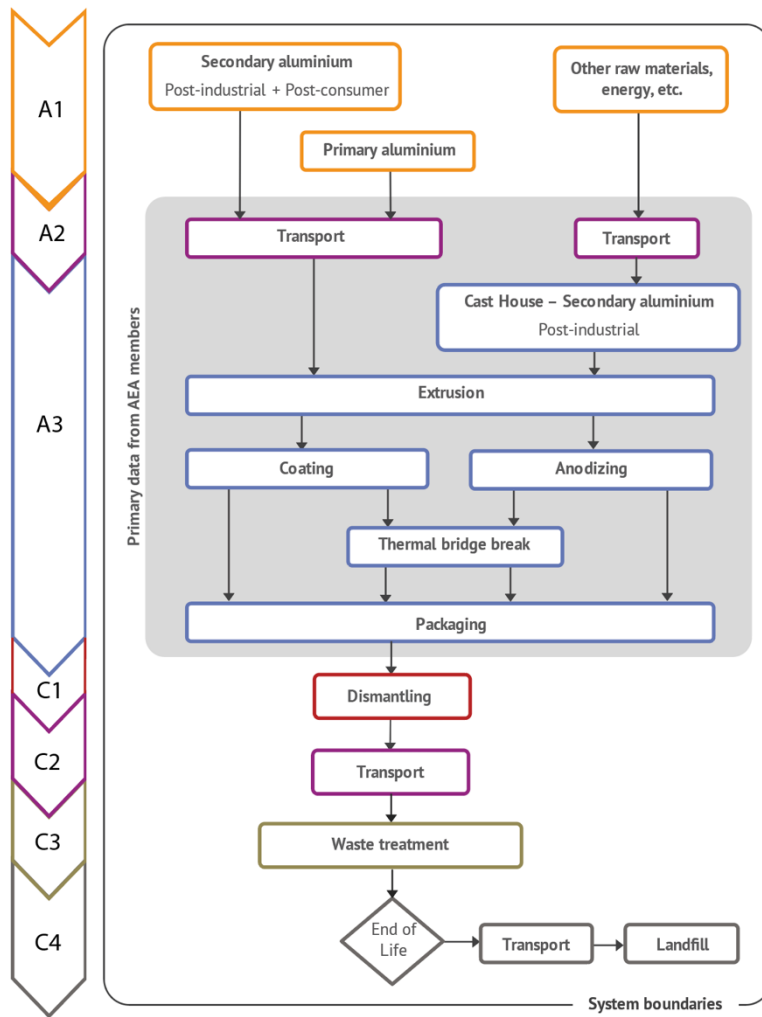

Figure 8.4: Anodized and Coated Aluminium Profiles flow chart of production A1 – C4. Source: Modified by AEA.

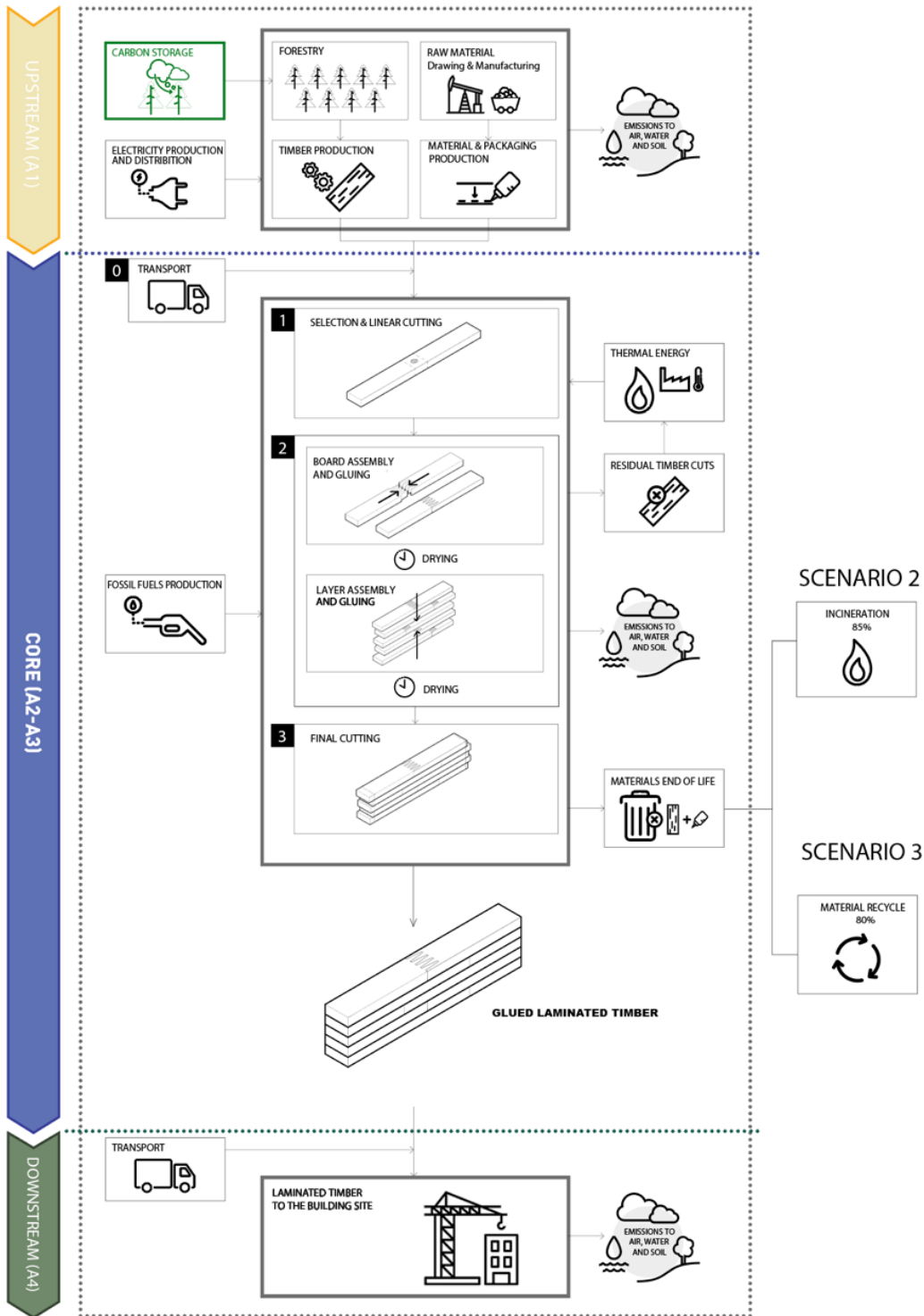

Figure 8.5: Timber flow chart of production A1 – A4. Source: Modified by L.A Cost srl. 2021

8.6. Materials Quantities

The material quantities for the aluminium curtain wall and the biobased façade system are shown in the tables below. The bio-based façade system is heavier than the aluminium one due to the increase of the frame depth to account for deflections.

Scenario 1 – Aluminium Unitised CW

Materials	Total Quantity [kg]	Environmental Profile
Aluminium Powder Coated	42.3	Powder Coated Aluminium Extrusion
Aluminium Anodized Extrusion	5.7	Anodized Aluminium extrusion
Aluminium Powder Coated Sheet	14.08	Powder Coated Aluminium sheet
Thermal Breaks	2.97	Glass fibre reinforced polyamide, production, crimping
Silicone	2.95	Silicone production
EPDM Gasket	10.98	Synthetic rubber
Insulation	27.07	Stone wool production
TGU	170	Triple glazing system
Galvanized steel Sheet	21.15	Galvanized steel hot-rolled plate
Miscellaneous plastic and foam	1.82	PVC
Stainless-Steel Fasteners	1.14	Stainless-steel production and processes
Total	321.37	

Table 24: Material Quantities for Aluminium CW System – Scenario 1

Scenario 2 & 3 – Bio-Based Unitised CW

Materials	Total Quantity [kg]	Environmental Profile
Oak Glulam	79.60	Glued Laminated Timber production
Plywood Sheathing	8.4	Plywood production
MDF Sheathing	16.1	Medium density fibre board production
HPL Cladding	18.7	HPL panels for facades
Softwood	6.36	Softwood lath, kiln dried
Silicone	6.56	Silicone production
EPDM Gasket	16.39	Synthetic rubber
Insulation	16.22	Mycelium production
TGU	170	Triple glazing system
Aluminium Anodized Extrusion	10.11	Anodized Aluminium extrusion
Miscellaneous plastic and foam	1.39	PVC
Stainless-Steel Fasteners	9.49	Stainless-steel production and processes
Total	378.49	

Table 25: Material Quantities for Bio-based façade system – Scenario 2 & 3

8.7. Results

The following figures show the carbon emissions [kg CO₂ eq] of an individual façade component per environmental impact category.

Due to the organic nature of the bio-based façade concept, the global warming potential, fossil, biogenic, LULUC, and water-deprived [m³] environmental indicators are reviewed. It was expected to observe a reduction in carbon emissions between the aluminium curtain wall and the bio-based façade system scenarios due to the low embodied carbon content of bioproducts compared to traditional construction materials. However, special attention is given to the two bio-based scenarios and the impact that reusability has on the different categories. Also, it is important to analyse the impact that the individual façade components and their processes have on the overall system.

Global Warming Potential Total

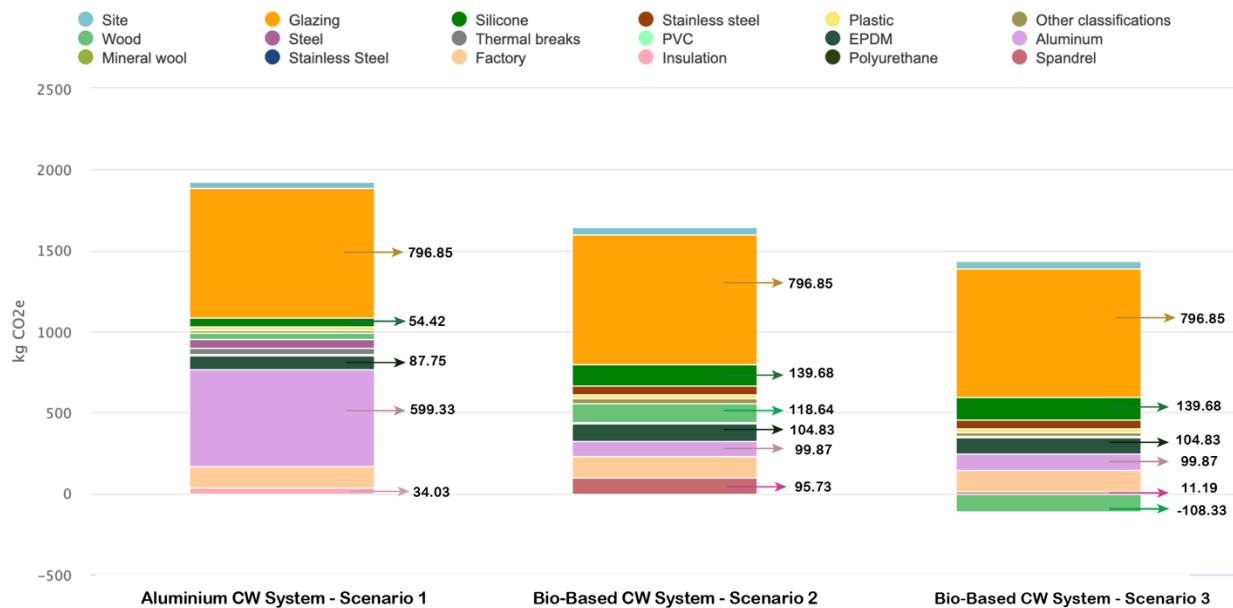

Figure 8.6: Global warming potential total, per element impact for the three façade system scenarios. Source: One Click LCA.

According to the analysis, the total carbon emissions of the façade systems under the three scenarios indeed display a decrease when introducing bio-based construction materials in façade design and construction against traditional construction products. The results for the total global warming potential (GWP) for the aluminium curtain wall ranked the highest with 1.92×10^3 kg CO₂ eq, while scenario 2 resulted in 1.63×10^3 kg CO₂ eq, and scenario 3, 1.32×10^3 kg CO₂ eq for the bio-based façade systems. Thus, showing a decrease of ~15% when opting for bioproducts and ~30% when reusability is introduced as an end-of-life strategy for the bio-based façade system against the aluminium curtain wall.

To understand the results and analyse the driving factors that contributed the most to the attained total carbon emissions of the three scenarios, the materials and processes implemented on the façade systems are overviewed.

The materials with the highest global warming potential (GWP) are the glazing system for the three scenarios with a total carbon emissions of 796.85 kg CO₂ followed by aluminium, 599.33 kg CO₂ in the aluminium curtain wall unit, and silicone, 139.68 kg CO₂ in the bio-based design concept scenarios. This is because, in the bio-based façade system, silicone is used for the discrete toggle connection and to hold together the outer glazing panes, as well as for the application of the continuous gasket system. In addition, there is a drastic change in the GWP for the spandrel and timber components for the bio-based curtain wall scenarios.

Scenario 2, which is the bio-based system with 85 % incineration at the end of life has a total of 118.64 kg CO₂ accounted for timber and 95.73 kg CO₂ for the bio-based spandrel. Contrastingly, Scenario 3, with the 80% reuse has a total of – 108.33 kg CO₂ for timber and 11.19 kg CO₂ for the spandrel. The difference between the impact of timber and spandrel components in both scenarios shows a pronounced reduction in carbon dioxide emissions when applying reusability as an end-of-life strategy for the materials. Thus, the reduction averages 88.3 % for the contributed emissions by the spandrel and close to double the amount of the carbon emissions produced when the timber gets incinerated and landfilled.

Another important parameter to overview is the impact that life cycle processes have on the different façade scenarios. As noted in Figure 8.7, phase A1, extraction and processing of raw materials, is the process that contributes the most to carbon emissions. Just by the introduction of bioproducts alone in the design and construction of façade systems, there is a reduction of ~70.5 % in emitted carbon quantities for the raw material extraction and processing stage compared to standard aluminium façade units, which mainly rely on non-renewable resources for its production.

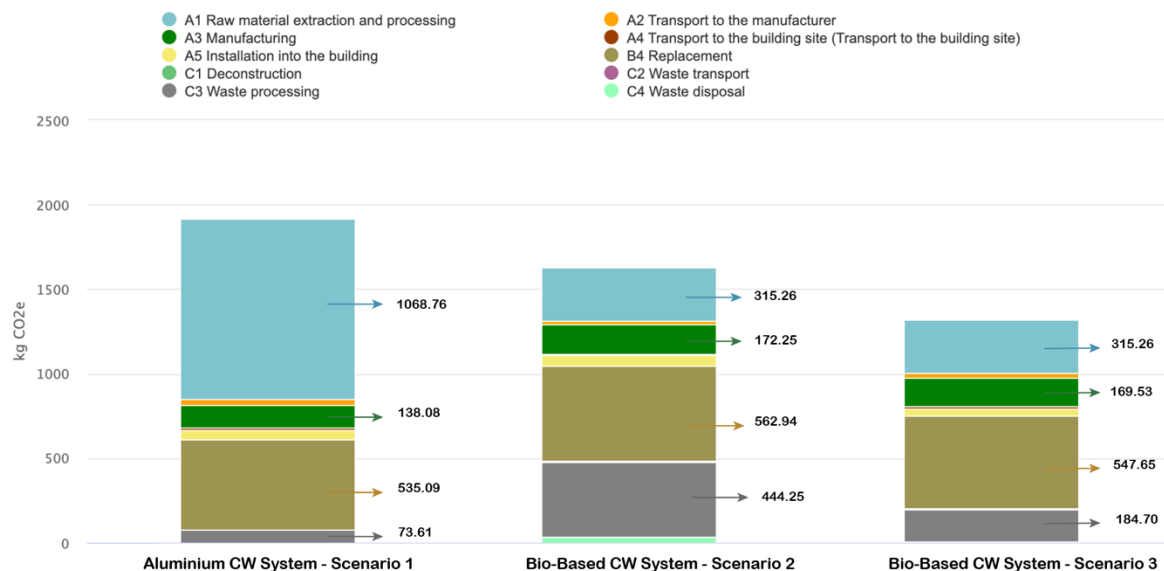

Figure 8.7: Global Warming potential total by life cycle stage for the three façade system scenarios. Source: One Click LCA

Another phase that ranked the highest among the three scenarios is replacement, B4. In this stage, the three scenarios share close values, however, the bio-based façade concept marked the highest due to the increment of silicone and EPDM gaskets in their design compared to the aluminium façade. The results are also attributable to the dynamic design of the bio-based concept, which focuses on ease of assembly and disassembly allowing the system to be dismantled and updated compared to the aluminium curtain wall, where only certain materials can be accessed for replacement. Thus, maintenance, replacement, and

production of the updated gaskets, silicone, and other components such as rain-screen cladding are accounted for in this phase.

Lastly, there is a noticeable difference in the waste processing phase C3 for the three concepts. The bio-based façade system under scenario 2, has the highest impact against the standard aluminium curtain wall. This is explained because the quantity of products used for the bio-based façade system is more than the aluminium curtain wall, therefore there is less of the material's mass to be waste processed for recycling and incineration. Furthermore, the aluminium façade unit is modelled to be recycled while the bio-based systems have a higher number of components that need to be incinerated or landfilled. Also, within the bio-based scenarios, there is a drastic reduction of ~59% in the C3 phase when applying reusability at the end-of-life of the materials.

Reusability is one of the most effective techniques to lower carbon emissions in the building envelope since it is referred to as the process where the materials used are produced from the same material's composition as in their previous life iteration without being transformed. Therefore, the function of the product remains the same throughout its lifespan with no added energy-intensive process related to recycling, and virgin material extraction and production, in between its different uses [Douguet 2022]

Global Warming Potential Fossil

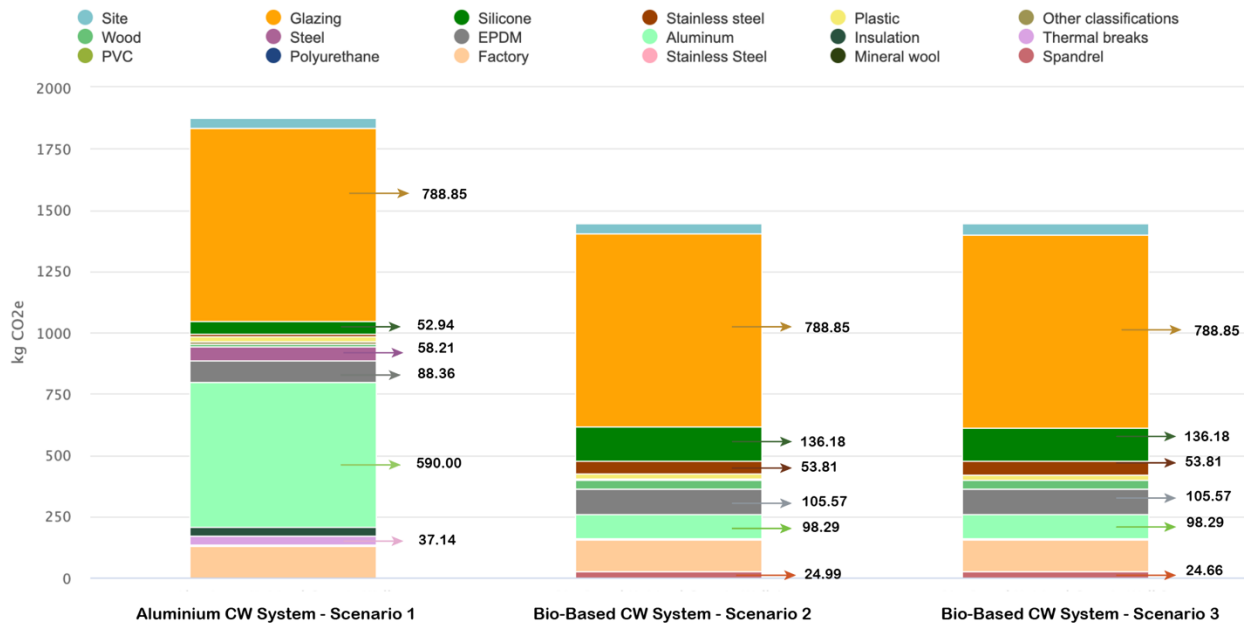

Figure 8.8: Global warming potential fossil, per element for the three façade system scenarios. Source: One Click LCA.

The analysis for the fossil global warming potential, resulting from the oxidation or reduction of fossil fuels and fossil carbon from combustion, indicates that glazing and aluminium are the materials with the highest impact, scoring 788.85 kg CO₂ and 590 kg CO₂ respectively. Silicone and EPDM gaskets in the bio-based façade system scenarios also have the highest value with 136.18 kg CO₂, and 105.57 kg CO₂ after the glazing unit.

To analyse the impact of reducing the reliance on aluminium. It becomes evident that by cutting the mass of aluminium, and only using it for the anchor slides and plates as is the case of the bio-based façade

scenarios, there is a reduction of 83.35 % in carbon emissions related to aluminium usage. However, the glazing system raises a concern because of its high carbon impact, thus reducing the amount of glazing needs to be further investigated.

Taking into consideration the impact of the life cycle processes, the production stage A1-A3, referred to the extraction and manufacturing of the building materials has the highest impact on fossil-related carbon emissions, which also shows a reduction of ~37 % when applying bio-based construction materials against standard materials. Thus, these values could be further reduced if renewable energy is applied in the production stage.

Global Warming Potential Biogenic

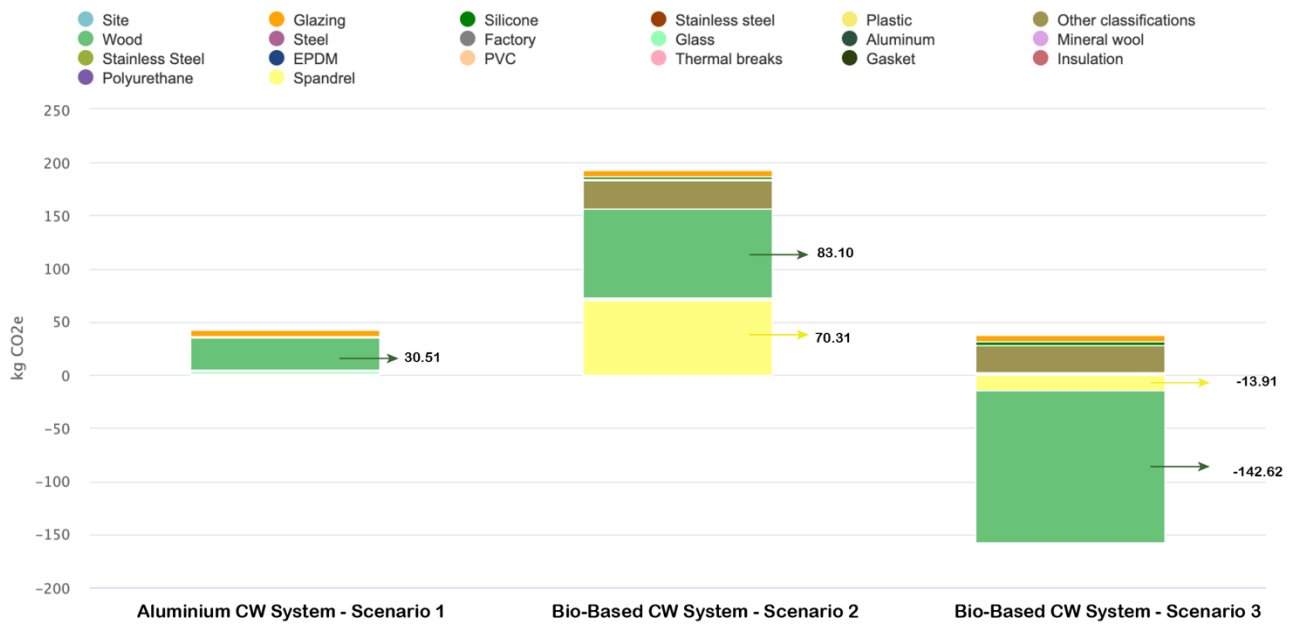

Figure 8.9: Global warming potential biogenic, per element for the three façade system scenarios. Source: One Click LCA.

The biogenic global warming potential is another important analysis when assessing renewable materials. For this analysis, biogenic carbon is accounted as carbon storage, where the carbon uptake throughout the bioproducts growth phase is considered. Thus, special attention is placed on the release of the sequestered carbon and the impact that reusability has on biogenic carbon emissions.

The biogenic carbon emissions for the bio-based façade unit in scenario 2 ranked the highest with a total biogenic carbon of 191.98 kg CO₂ eq, where the materials that contributed the most are the timber frame (83.10 kg CO₂ eq) and bio-based spandrel (70.31 kg CO₂ eq). This is because 85 % of the bioproduct's mass is incinerated and 10 % is placed in a sanitary landfill as an EoL strategy. Sanitary landfills for reactive products such as bio-based materials pose a high environmental impact since organic materials normally release methane (CH₄) during their decay. [Pittau 2018]

To further alleviate the impact of a sanitary landfill, placing the materials in a composting facility instead can be beneficial since the biogenic materials are treated and the produced methane during decay is captured. However, a thorough investigation of the potential benefits and constraints of using a composting

facility as an end-of-life strategy needs to be studied. For the incineration treatment, thermal energy recovery is assumed through the combustion process of the materials. However, the energy recovery is only a percentage and there is still a fraction of the sequestered carbon released to the environment.

Following scenario 2, the aluminium cw system contributes 40.18 kg CO₂ eq for biogenic carbon emissions, fairly low compared to the bio-based façade system. This is attributable to the restricted use of wooden materials (30. 51 kg CO₂,) only accounted for packaging to transport the façade elements. Lastly, scenario 3 with the 80 % reuse, has the lowest biogenic carbon emissions having a total of -117.23 CO₂ eq, where the timber frame and bio-based spandrel are the major contributors. By extending the lifespan of the bioproducts, carbon fixation becomes beneficial since the sequestered carbon can be locked for an extended period.

It is important to note that carbon fixation even though presents environmental benefits, doesn't compensate for the processes-related emissions across the life cycle of the building elements. However, implementing different strategies starting at the material level, design, and EoL scenarios, can efficiently decrease the environmental impact caused by construction materials.

Global Warming Potential LULUC

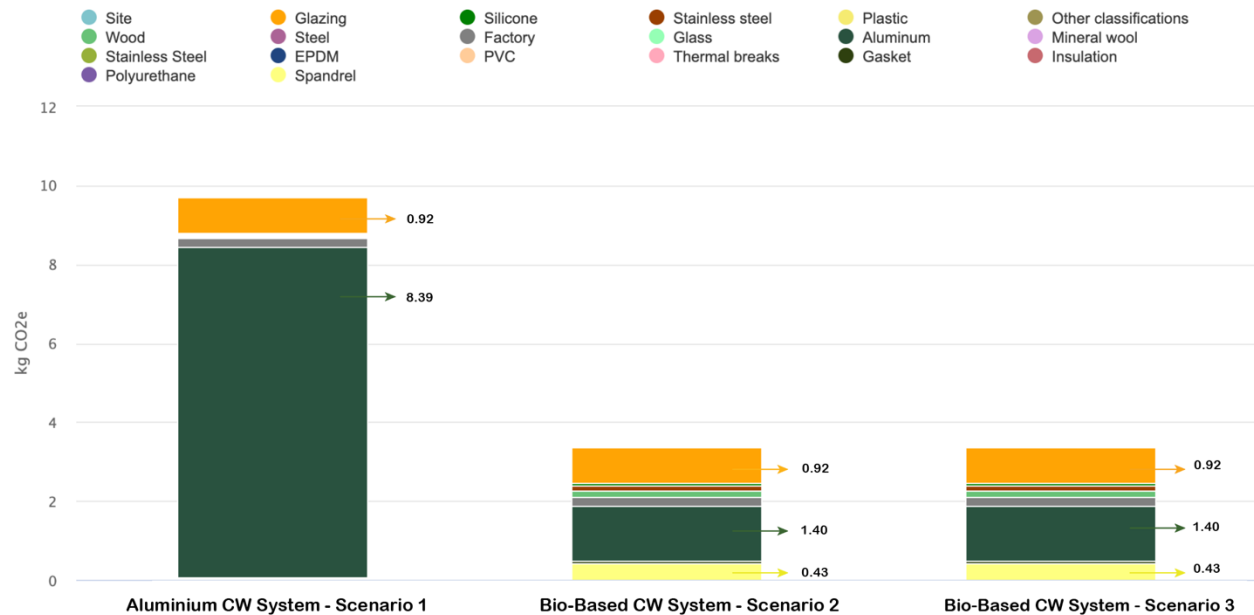

Figure 8.10: Global warming potential LULUC, per element for the three façade system scenarios. Source: One Click LCA.

The environmental impact of anthropogenic land-use are important to consider mostly when using bio-based products. The results show the highest value corresponding to aluminium for the aluminium curtain wall system. However, the total carbon emission from aluminium is only 8.39 kg CO₂, while for the bio-based scenarios, the impact of aluminium goes further down to 1.40 kg CO₂. The analysis shows results that are very small compared to the carbon emissions from the other categories, therefore the category impact can be neglected for this case study.

Global Warming Potential – Water Use [m³]

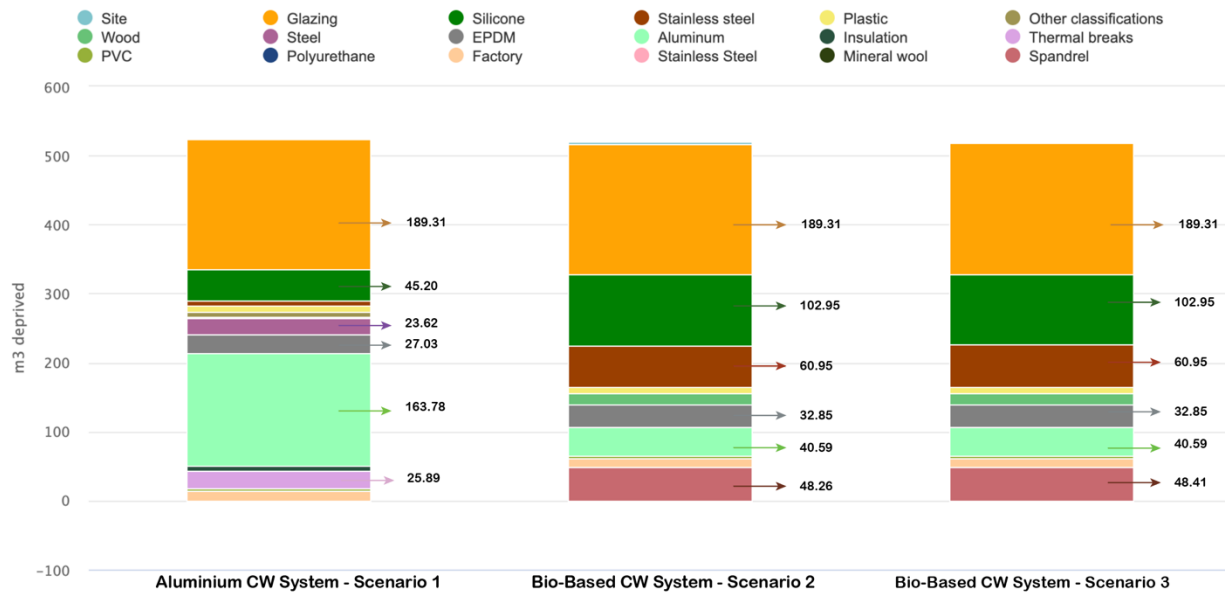

Figure 8.11: Global warming potential Water usage [m³], per element for the three façade system scenarios. Source: One Click LCA.

Water consumption among construction materials and processes is another important environmental indicator to analyse for decision-making. The results are expressed in volumetric quantities to understand the volume of water used to produce the façade components and processes encompassing the façade unit. The analysis of the three scenarios shows very close values, where the system with the highest impact is the aluminium curtain wall with a total of 525 kg CO₂ eq, followed by scenario 3, the bio-based system with an emphasis on reusability with 520.33 kg CO₂ eq, and scenario 2, with 519.58 kg CO₂ eq, showing an average variation of ~ 1 % within the three design concepts.

Analysing the impact of the materials, the glazing system has the highest effect on water consumption among the three scenarios with 189.31 m³ of water used. The second highest material is aluminium (163.78 m³) for scenario 1, and silicone (102.95 m³) for scenario 2 & 3. As already explained the increase of silicone is because it is used in the continuous gaskets and the discrete toggle connection. However, there is a significant reduction in water usage related to aluminium, by reducing the aluminium application to only the anchoring system as is the case of the bio-based system scenarios, thus the water usage related to aluminium mass goes down by ~75 %.

For case scenarios 2 & 3, there is an increment in water use for the application of stainless steel and the spandrel, still, their implementation only accounts for 12 % and 9% respectively for the whole system. However, it is important to remark that the glazing system is the major contributor to water consumption, and other important environmental indicators due to its production, installation, and service life. Therefore, mitigation strategies to optimize its application while maintaining optimal operational performance and aesthetics need to be further studied.

8.8. Conclusions

The results of the cradle-to-grave life cycle assessment show as seen in Figure 8.12 the overall embodied carbon per m² of the façade unit of the three scenarios. Scenario 1, the aluminium curtain wall system has a total embodied carbon of 355.5 kg CO₂ eq/m², while scenario 2, the bio-based façade system with 85 % incineration marked 301.8 kg CO₂ eq/m², and scenario 3, with an emphasis on reusability, ranked the lowest with 244.4 kg CO₂ eq/m². Thus, showing an average reduction of 31% of embodied carbon per m² when introducing bio-based materials and reusability as an EoL strategy for the façade elements.

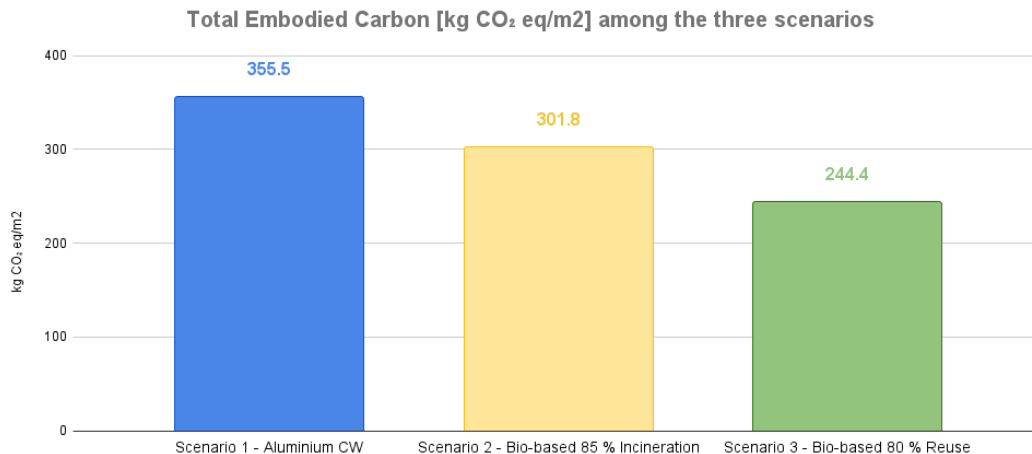

Figure 8.12: Total embodied carbon per m² of façade unit among the three analysed scenarios. Source: by author

To understand which materials and processes contributed the most to the total embodied carbon of the three scenarios, the façade elements and their processes are also analysed for the chosen environmental impact categories. Within the overviewed environmental indicators special attention needs to be paid to the fossil global warming potential since it is the category that influences the overall global warming emissions the most. The energy required for the extraction, production, installation, and replacement comes in its majority from non-renewable resources, thus finding renewable energy solutions is an important step in reducing embodied carbon emissions.

Looking at the impact materials pose on the overall emitted carbon; it can be concluded that the glazing system is the façade element with the highest embodied carbon content within the three scenarios. Followed by aluminium profiles in the aluminium curtain wall and silicone in the bio-based façade system. However, the introduction of bio-based façade systems does help mitigate the use of aluminium in façade design, therefore cutting the aluminium mass from scenarios 1 to 2 shows a reduction of ~83% of aluminium embodied carbon.

Analysing the bio-based façade unit, there is an increment of carbon emissions related to the silicone applied in the system. The material is present in the toggle connection and in the continuous gasket system to protect the timber frame. However, its application can be further reduced by optimising the gasket design to lower the quantity of material used.

Furthermore, the application of glazing needs to be addressed in the design phase to find ways to reduce its environmental impact. Design strategies can be implemented to decrease the amount of glazing while still achieving optimal lighting, thus lowering the amount of material needed. Also, further investigation needs

to be made to review the recyclability potential of glass and mitigation strategies at the design level that could be implemented to lower the current high embodied carbon impact that glass has in the construction industry.

Some alternatives applicable to the case study can be implementing low carbon glazing which due to the combination of renewable energy and high cullet content in its production, can reduce the carbon footprint by 42 % [Saint Gobain] while achieving the same performance parameters as standard glazing.

Another important factor to overview is the impact of the glazing system on the operational performance of the building. Such results can help clarify if the operational carbon of the building can be offset by the application of a triple-glazing system to justify its application or if a double-glazing system can optimally be introduced instead, thus reducing the amount of glazing in the façade system.

Overall, understanding the impact that materials and design methodologies have on embodied carbon and operational performance is key to applying strategies that can efficiently contribute to reducing the carbon content of buildings and façade systems. Also, this case study has shown that only relying on sustainable practices at the material level is not enough, yet the integration of bio-based materials, dynamic design strategies, and applying circularity with an emphasis on the reuse loops of construction materials, are efficient strategies to act against the current high carbon footprint that the construction industry is responsible for.



9. SUMMARY & DISCUSSION

9. Summary & Discussion

9.1. Primary Findings

The key findings of the research are categorized within the material, design, and system level. Starting at the material phase, the research has proven the feasibility of bio-based materials as competitive construction products. It has also brought to light, the importance of understanding and analysing the chosen components in the design phase to plan and design according to the properties of bio-based materials and enhance their performance within the system. Despite, the difficulty in standardizing the use of bio-based materials, owing to their hygroscopic characteristics, the increment of their application is progressively aiding the understanding and development of standard paths of action. The variability in their behaviour in construction settings highlights the need for a hygrothermal assessment before final design implementation.

On the design level, the integration of bioproducts with a modular design approach has been supported by this case study, showing improvements not only from a sustainable perspective but also on a technical level. The implementation and assessment of boundary conditions such as acceptable moisture content, maximum relative humidity, propensity to condensation, shrinkage, and technical properties of the material are critical to achieving a feasible system.

Thus, for this case study, the assessment of the boundary conditions revealed the importance of breathability in the system when using organic products, particularly timber. Design concepts with freedom of moisture transfer are key to allow for the materials to release the absorbed moisture and dry out. Therefore, this case study supports the claim that bioproducts can be as competitive as traditional materials yet due to their organic nature and susceptibility to moisture retention, moisture control strategies are important features to implement.

Moving to the system level, the research underscores the significant environmental benefits of incorporating circularity in a bio-based modular system. A comprehensive review of the life cycle environmental analysis showcases the reduced environmental impact achieved by implementing reusability in a modular facade system composed of bio-based materials. The comparative analysis performed in this case study showed an overall reduction of ~30% when replacing the traditional end-of-life material allocation with restoration and repurposing. Yet, a higher reduction was expected, these results identified fossil carbon emissions as the environmental category with the highest impact, where even in the case of bioproducts, the raw material extraction and production phase depend on fossil-related energy.

Therefore, the importance of establishing a circular economy where all the stakeholders involved in the sourcing, transportation, production, assembly, and end-of-life allocation of construction materials are shifted toward product decarbonization is the most effective way of transitioning towards a low-carbon economy, which can simultaneously alleviate the reliance and depletion of abiotic resources and tackle climate change.

Circular economy [CE] is a strategy that incorporates the environmental well-being, societal benefits, and economic outlook through a system thinking approach, where the components of a system will be used as starting material/input for another by closing the loop and keeping the material in use [MacArthur 2020]. Thus, this economic concept promotes an effective resource recovery while reducing environmental burdens, where key principles established by CE are designing out waste and pollution, keeping products and materials in use, and regenerating natural systems. [McArthur 2013]

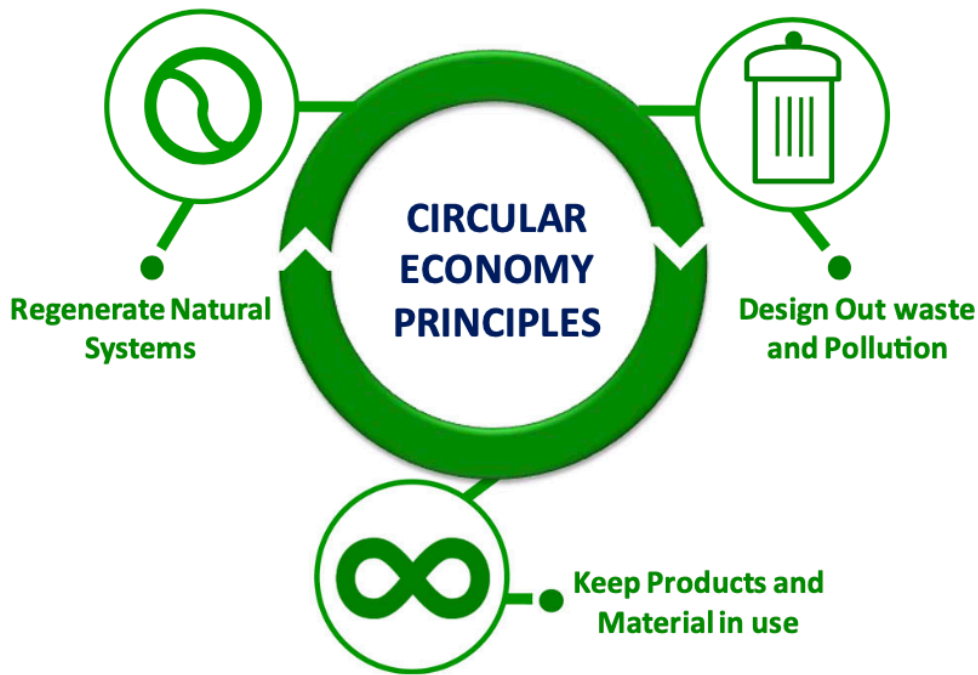

Figure 9.1: Principles of circular economy. Source: Shikha 2020

Overall, the findings advocate for the integration of sustainable dynamic approaches in façade design and construction, where design for disassembly and ease of system reconfiguration, are important features to promote a circular economy since the system is designed with an emphasis on reusability and material recovery. Consequently, implementing renewable resources in circular and dynamic design features is a tangible and effective solution for mitigating the environmental challenges confronted by the built environment.

9.2. Secondary Findings

- Aesthetical Value & Well-Being



*Figure 9.2: Kroon Hall, Yale University (left) & The Odgen Centre for Fundamental Physics (right).
Source: Arup 2011*

The bio-based design concept has been designed with the objective of enhancing the aesthetic appeal of the building envelope. The façade industry is recognized for its rapid change of rate, where alterations in appearance or functionality could prematurely rate a system outdated, despite the optimal performance of the façade components. In this light, the introduction of a façade design that can stay relevant through time is important to mitigate the frequent need for façade reconfigurations, thus the use of timber and its warmth appeal can help alleviate this accelerated rate of change.

In alignment with this perspective, the façade concept integrates a minimalistic approach, aiming to amplify the transparency of the façade. This goal is further accentuated by the use of a discrete toggle connection, eliminating the need for a frame around the glazing unit, thus increasing the system's transparency and enhancing natural light in the building's interior. The visible timber frame within the interior not only increases the aesthetic value but also contributes to a smooth, warm appearance, as the frame edges have been flattened.

The exposure of wood and other bio-based materials within internal spaces can also help diminish occupant stress and increase positive responses, as supported by research. This is attributed to the innate human affinity towards nature and natural materials, which have been demonstrated to mitigate depression risks and promote long-term health improvements [Nyrud 2010].

Nevertheless, there is a health concern regarding the utilization of chemicals in the gluing process of lamellas in engineered wood products, such as glulam. Moreover, preservative treatments and coating to increase timber durability can also pose a concern. Addressing these issues, the design concept utilizes untreated oak glulam, not only because of health concerns but also to not interfere with the recyclability potential of the material.

Overall, the integration of bio-based materials within the façade design has an added value not only from the sustainability perspective but also by improving the user's comfort and creating a pleasant space.



10. CONCLUSIONS & RECOMMENDATIONS

10. Conclusions & Recommendations

10.1. Research Questions

1. *What's the feasibility of introducing circular bio-based façade systems against aluminium frame curtain wall systems in terms of, environmental impact, lifespan iterations, and operational performance?*

To assess feasibility a comprehensive analysis needed to be made. Circularity together with bio-based materials can pose challenges to creating a system that is not only functional but that complies with optimal construction standards. From an environmental perspective, introducing circularity to the building envelope is beneficial, since it supports practices such as design for disassembly, and adaptability, leading to resource conservation and a reduced reliance on the conventional waste-landfill cycle.

Therefore, when these principles are paired with bio-based materials, the benefits can be magnified. However, the inherent characteristics of these materials do introduce certain challenges during the design phase. Effectively navigating these challenges is paramount to harnessing the potential advantages of bio-based materials.

A major difficulty with bio-based materials is their specificity. Unlike standardized aluminium frame systems, the behaviour of bio-based materials is highly dependent upon their surroundings, demanding thorough analysis and understanding prior to their utilization. However, it's important to highlight that bio-based materials, when applied properly, can be exemplary construction materials. Not only do they exhibit optimal performance, but they also counteract the environmental degradation typically caused by conventional, carbon-intensive construction materials. Therefore, a commitment to investigating and employing these materials is fundamental for advancing sustainable construction methodologies.

2. *Can bio-based unitised curtain wall façade systems be implemented without reliance on aluminium or any other carbon-intensive materials?*

Bio-based unitised curtain wall systems can be implemented without the reliance on aluminium or any other carbon-intensive materials. Yet, it can't be generalised. Factors like climatic conditions that the system is subjected to, specific design objectives, and the type of materials chosen are key parameters to determine the successful implementation of unitised bio-based façade systems.

The hygrothermal characteristics of bio-based materials require a comprehensive analysis, mostly of their reactions under distinct weather conditions. This examination is crucial to determine the material's resilience against such external factors. It also aids in optimising the design specifics to improve the structural integrity of both the materials and the overall façade system.

While bio-based materials can be very competitive materials against standard construction materials, they come with their own set of vulnerabilities, where they can exhibit sensitivity to water infiltration and can be easily susceptible to biodeterioration if proper measures are not taken.

In the specific case of unitised façade envelopes, due to their modular characteristics, are usually assembled on-site, which poses challenges to the integrity of the materials. Given their predisposition to moisture-related biodeterioration, the materials can lose their mechanical properties and failure in the system may

occur. In addition, when implementing unitised design parameters with organic materials, airtightness, and moisture control mechanisms need to be implemented to ensure their operation lifespan.

In conclusion, unitised bio-based systems can be applied without the reliance on aluminium. However, its utilization is case-specific and a hygrothermal analysis is needed at the early stages of the design to provide a foundation for design improvements and guarantee the service life of the system. Yet, proper analysis is not enough. Safety measures like water management control need to be taken from the builder's perspective to ensure the structural integrity of the materials.

3. *What are the constraints bio-based materials bring to the design of unitised curtain wall systems? And what measures can be taken to address them?*

Regardless of the benefits of using Bio-based materials, they can also present certain challenges due to their biological nature. A primary limitation of these materials is their sensitivity to climatic conditions. Bioproducts are especially susceptible to moisture and water ingress, making it imperative to design systems that effectively control vapour transmission. In addition to moisture concerns, bio-based materials can also degrade over time due to mould growth or insect attack. Consequently, improvements in the secondary layer of defence, and including gaskets to shield the material, or adding membranes that can block vapour or control it are helpful approaches to increase the serviceability of bio-based materials.

Furthermore, the fire resistance of bio-based materials is a crucial factor to consider since many organic materials can be flammable. To reduce the risk of fire propagation, compartmentalization within the façade layers can be implemented, which together with airtight facade systems are an optimal combination. Introducing coatings can also be beneficial against fire, however, it is important to consider the nature of the coatings if the reusability of the material is intended.

Above all, periodic maintenance and inspection of the building envelope are important. Such practices can pre-emptively identify and help address signs of material degradation, ensuring the service life and performance of bio-based systems.

10.2. Limitations & Areas for further analysis

Throughout the assessment of this case study, limitations have been discovered within the different phases, material, concept design, performance validation, and overall system. However, such current limitations welcome new areas of research to improve and support the benefits of introducing circular bio-based façade systems as an effective approach to lower the current carbon footprint in the built environment.

- **Material Level**

Bio-based materials are still at a novel phase, therefore required certifications and authentications for their implementation in the construction sector are not readily available yet and, in some cases, further testing to support their durability needs to be assessed. So far, this has been the biggest challenge at this phase, since there is a lack of published information about their composition.

Due to their novel nature, bio-based materials remain underutilized in large-scale projects, primarily owing to their lack of exposure in the market. This presents an opportunity for their introduction in larger projects, which can more easily absorb and justify the costs of testing materials for the intended application.

This is the case of the mycelium insulation used in this research, where there is still a lack of published reports to overview its technical properties and durability assets.

Another important limitation starting at the material level and closely connected to the design phase is the current regulations established by governments, where building codes are centred on traditional materials such as concrete and steel. These current policies make the use of bio-based materials more difficult compared to standard materials, contributing to the current gap related to enacted regulations, and effective measuring methods related to the capabilities, limitations, and potential assets of bioproducts.

By updating the policies and further testing on a larger scale the capabilities of bio-based materials in the construction industry, the risk in their application in the built environment can be reduced while diminishing the carbon footprint and creating efficient, safe, and durable buildings.

- **Circularity**

The combination of circularity and bio-based materials is changing the perception of the built environment since there is a need to see organic materials as part of a bigger building product or block, not only at the material level. Therefore, the focus should be on the characteristics and needs of these configurations instead of the product itself. Shifting the focus to more complex configurations can help design and apply more dynamic systems where circularity is less of a challenge.

On the life cycle assessment, limitations are also present regarding the availability of technical information and environmental product declaration documents (EPDs) for bio-based materials, which becomes difficult since assumptions have to be made in this section. Manufacturers are not mandated to include modules B, C, or D on their environmental declaration reports, since a typical EPD is not obligatory to carry all of the product's life cycle information. For the life cycle analysis of the bio-based design concept, module D had to be left out of the analysis since there is a lack of information regarding the allocation of certain bio-based materials at the end of their life.

- **Structural Analysis Overview**

The case study scope was surrounded by the feasibility of the bio-based materials from a building physics perspective, prioritizing the thermal and hygrothermal analysis of the bioproducts to properly be used in the design concept. Even though structural guidelines were followed, a proper structural analysis is needed to account for the dimensions of the timber frame. So far, the dimensions are aligned with safety and structural guidelines, but the framing proportions can be further reduced, such a decrease in the frame dimensions improves the sustainability of the system since less material will be needed.

In addition, a structural design overview of the slotted stainless-steel plate connection is required. The slotted connection is designed to account for a hole diameter surpassing the fasteners by 2 mm. This recommendation, however, needs further research, specifically addressing the structural integrity of the timber when subjected to live and dead loads.

Overall, the limitations and future opportunities of the application of circular bio-based façade systems offer a clearer picture of the path of action to efficiently move towards a more resilient, dynamic built environment. The focus of this circular approach centres on cross-disciplinary collaboration among the involved stakeholders to produce decarbonized products, promote research, and update regulations that allow the assessment of the materials while incentivising dynamic design at a bigger scale. Another important challenge is changing the perception of investors and clients when introducing a circular economy, where higher investment costs can be an obstacle, but where improvements in sustainability and circularity present opportunities in the long term both financially and environmentally.



11.

REFERENCES

11. References

- Accoya Innovation in Wood. (2023, July 6). Accoya | Acetylated Wood | Modified Wood, treated wood, Accoya. Accoya Acetylated Wood | High Performance, Long Life Modified Wood. <https://www.accoya.com/>
- Allsopp, D.; Seal, K.J.; Gaylarde, C.C. *Introduction to Biodeterioration*; Cambridge University Press: Cambridge, UK, 2004.
- Al-Qahtani S, Koç M, Isaifan RJ. Mycelium-Based Thermal Insulation for Domestic Cooling Footprint Reduction: A Review. *Sustainability*. 2023; 15(17):13217. <https://doi.org/10.3390/su151713217>
- Anderson, Brian & Kosmina Ludmilla. Conventions for U -U-value calculations. (2019) https://www.bregroup.com/wp-content/uploads/2019/10/BR443-October-2019_consult.pdf
- Arup, (2019). Rethinking Timber Buildings. Seven perspectives on the use of timber in building design and construction. Available at: <https://www.arup.com/perspectives/publications/research/section/rethinking-timber-buildings#>
- BauBuche Manufacturer, <https://www.pollmeier.com/baubuche/>
- Bekkering Juliette, Nan Cristina, Schröder Torsten (eds.) (2021). *Circularity and Biobased Materials in Architecture and Design. Evaluation of the Status Quo and Defining Future Perspectives.*
- BioBuild Façade System, Arup. <https://www.arup.com/projects/biobuild-facade-system>
- Sandak, Anna & Sandak, Jakub & Marcin, Brzezicki & Kutnar, Andreja. (2019). State of the Art in Building Façades. 10.1007/978-981-13-3747-5_1.
- Brambilla, Arianna & Gasparri, Eugenia. (2021). Mould Growth Models and Risk Assessment for Emerging Timber Envelopes in Australia: A Comparative Study. *Buildings*. 11. 261. 10.3390/buildings11060261.
- Brambilla, A., & Gasparri, E. (2020). Hygrothermal behaviour of emerging timber-based envelope technologies in Australia: A preliminary investigation on condensation and mould growth risk. *Journal of Cleaner Production*, 276, 124129. <https://doi.org/10.1016/j.jclepro.2020.124129>
- Cabral, J.P., Kafle, B., Subhani, M. *et al.* Densification of timber: a review on the process, material properties, and application. *J Wood Sci* **68**, 20 (2022). <https://doi.org/10.1186/s10086-022-02028-3>
- Cascone, Stefano. (2016). Analysis and design of unitized curtain walls. Growing our low-carbon future. Time for Timber. https://www.cei-bois.org/files/ugd/5b1bdc_2dc33151278e43e483e2b06e3d281f6e.pdf
- Cascione Valeria, Matt Roberts, Stephen Allen, Barrie Dams, Daniel Maskell, Andy Shea, Pete Walker, Stephen Emmitt, Integration of life cycle assessments (LCA) in circular bio-based wall panel design, *Journal of Cleaner Production*, Volume 344, 2022, 130938, ISSN 0959-6526, <https://doi.org/10.1016/j.jclepro.2022.130938>.

Corcoran, Lee & Duffy, Aidan & Rouholamin, Sima. (2013). A hygrothermal analysis of international timber frame wall assemblies tested under temperate maritime climatic conditions.

Crowther, Philip. "Re-valuing construction materials and components through design for disassembly." *Unmaking Waste in Production and Consumption: Towards the Circular Economy*. Emerald. Publishing Limited, 2018.

C. Sandhass, H.J.BlaB, (2017), Timber Engineering Book, Principles for Design

Dams, B., Maskell, D., Shea, A., Allen, S., Driesser, M., Kretschmann, T., Walker, P., & Emmitt, S. (2021). A circular construction evaluation framework to promote designing for disassembly and adaptability. *Journal of Cleaner Production*, 316, 128122. <https://doi.org/10.1016/j.jclepro.2021.128122>

Dahiya, Shikha & Katakajwala, Ranaprathap & Ramakrishna, Seeram & Venkata Mohan, S. (2020). Biobased Products and Life Cycle Assessment in the Context of Circular Economy and Sustainability. *Materials Circular Economy*. 2. 7. 10.1007/s42824-020-00007-x.

Deniz, Omer & Doagn, Ebru. (2014). Building Façade System for Deconstruction. *Journal of Sustainable Architecture and Civil Engineering*. 8. 10.5755/j01.sace.8.3.7231.

Douguet, Etienne & Wastiels, Lisa & Laetitia, D. (2022). Evaluating ‘reuse’ in the current LCA framework – Impact of reuse and reusability in different life cycle stages. IOP Conference Series: Earth and Environmental Science. 1078. 012015. 10.1088/1755-1315/1078/1/012015.

Durmisevic, E. (2019). Circular economy in construction design strategies for reversible buildings. BAMB, Netherlands.[Online] Available at: bamb2020. eu/wp-content/uploads/2019/05/Reversible-BuildingDesign-Strategies.pdf [Accessed 18 October 2021].

Fundermax. (2022, October 5). Phenolic & High-Pressure Laminate Panels | Fundermax. <https://fundermax.us/>

Franke, Bettina & Franke, Steffen & Schiere, Marcus & Müller, Andreas. (2016). Moisture diffusion in wood – Experimental and numerical investigations.

Gasparri Eugenia, Mathew Aitchison, Unitised timber envelopes. A novel approach to the design of prefabricated mass timber envelopes for multi-story buildings, *Journal of Building Engineering*, Volume 26, 2019, 100898, ISSN 2352-7102, <https://doi.org/10.1016/j.jobbe.2019.100898>.

Gasparri, Eugenia & Brambilla, Arianna & Aitchison, Mathew. (2018). HYGROTHERMAL ANALYSIS OF TIMBER-BASED EXTERNAL WALLS ACROSS DIFFERENT AUSTRALIAN CLIMATE ZONES.

Georgios Eleftheriadis, Mohamed Hamdy. Impact of building envelope and mechanical component degradation on the whole building performance: a review paper, *Energy Procedia*, Volume 132, 2017, Pages 321-326, ISSN 1876-6102, <https://doi.org/10.1016/j.egypro.2017.09.739>.

Gradeci, K.; Labonnote, N.; Time, B.; Köhler, J. A probabilistic-based approach for predicting mould growth in timber building envelopes: Comparison of three mould models. *Energy Procedia* 2017, 132, 393–398. [CrossRef]

Gámiz, G. (n.d.). Grupo Gámiz | Specialists in top quality wood. Grupo Gámiz. <https://www.grupogamiz.com/en/>

Hartwell, Rebecca & Overend, Mauro. (2020). End-of-life Challenges in Façade Design: A disassembly framework for assessing the environmental reclamation potential of façade systems

Inma Roig, Biocomposites for interior facades and partitions to improve air quality in new buildings and restorations, Reinforced Plastics, Volume 62, Issue 5, 2018, Pages 270274, ISSN 0034-3617, <https://doi.org/10.1016/j.repl.2017.07.003>

IStructE. (2020). *How to calculate embodied carbon*. London: The Institution of Structural Engineers.

IStructE/ TRADA. (2007). *Manual for the design of timber building structures to Eurocode 5*. London: The Institution of Structural Engineers and TRADA technology Ltd.

Juaristi, M., Sebastiani, I., & Avesani, S. (2022). Timber-based Façades with Different Connections and Claddings: Assessing Materials' Reusability, Water Use, and Global Warming Potential. *Journal of Facade Design and Engineering*, 10(2), 71–86. <https://doi.org/10.47982/jfde.2022.powerskin.5>

Kamyar Kabirifar, Mohammad Mojtahedi, Changxin Wang, Vivian W.Y. Tam, Construction and demolition waste management contributing factors coupled with reduce, reuse, and recycle strategies for effective waste management: A review, *Journal of Cleaner Production*, Volume 263, 2020, 121265, ISSN 0959-6526, <https://doi.org/10.1016/j.jclepro.2020.121265>.

Kaufmann, Krötsch, Winter (2018), *Manual of Multi-Storey Timber Construction*

Kaya, Tuğba & Karagüler, Mustafa. (2017). The Effect of Relative Humidity and Moisture to the Durability of Spruce and Laminated Timber. *A/Z: ITU journal of Faculty of Architecture*. 14. 103-110. [10.5505/itujfa.2017.18480](https://doi.org/10.5505/itujfa.2017.18480).

Kelly DJ (2007) *Design life of buildings—a scoping study*. Scottish Building Standards Agency

Durmisevic, E. (2019). Circular economy in construction design strategies for reversible buildings. BAMB, Netherlands. [Online] Available at: [bamb2020. EU/wp-content/uploads/2019/05/Reversible-Building-Design-Strategies. pdf](https://bamb2020.eu/wp-content/uploads/2019/05/Reversible-Building-Design-Strategies.pdf) [Accessed 18 October 2021].

Kim, M., 2013. Efficiency and Feasibility of the Disassembly Process for Curtain Wall Systems (master's thesis). Delft University of Technology, Netherlands.

Knaack Ulrich, T. K., Marcel Bilow, Thomas Auer. (2007). *Facades_ Principles of Construction*. W.Y.Tam. (2006). *A Review on the Viable Technology for Construction Waste Recycling*.

L.A. COST srl. (2021). *Environmental Product Declaration _ Glued Laminated Timber*. Costantini Sistema Legno.

Lei, H., Li, L., Yang, W., Bian, Y., & Li, C. (2021). An analytical review on application of life cycle assessment in the circular economy for built environment. *Journal of Building Engineering*, 44, 103374. <https://doi.org/10.1016/j.jobe.2021.103374>

Lise Mouton, Karen Allacker, Martin Röck, Bio-based building material solutions for environmental benefits over conventional construction products – Life cycle assessment of regenerative design strategies (1/2), *Energy and Buildings*, Volume 282, 2023, 112767, ISSN 0378-7788, <https://doi.org/10.1016/j.enbuild.2022.112767>.

McArthur FE (2013) *Towards the circular economy Vol. 1: an economic and business rationale for an accelerated transition*. Ellen McArthur

MacArthur (2020). <https://www.ellenmacarthurfoundation.org/circular-economy/concept>. Accessed on 30th May 2020

Marriage, G. (2020). *Tall: The Design and Construction of High-Rise Architecture*. New York: Routledge Taylor & Francis Group.

Metsä Group – Your partner in sustainable growth. (n.d.). Metsä Group. <https://www.metsagroup.com/>

Mycelium: BIOHM: London (no date) BIOHM. Available at: <https://www.biohm.co.uk/mycelium>).

Mouton, L., Allacker, K., & Röck, M. (2023). Bio-based building material solutions for environmental benefits over conventional construction products – Life cycle assessment of regenerative design strategies (1/2). *Energy and Buildings*, 282, 112767. <https://doi.org/10.1016/j.enbuild.2022.112767>

Nyrud, A., Bringslimark, T. (2010). Is Interior Wood Use Psychologically Beneficial? A Review of Psychological Responses Toward Wood. *Wood and Fiber Science*. 42(2). p4.

Ouyang, Bai & Yin, Fangyu & Li, Zhu & Jiang, Jiali. (2022). Study on the moisture-induced swelling/shrinkage and hysteresis of *Catalpa bungei* wood across the growth ring. *Holzforschung*. 76. 10.1515/hf-2021-0222.

Pittau Francesco, Felix Krause, Gabriele Lumia, Guillaume Habert, Fast-growing bio-based materials as an opportunity for storing carbon in exterior walls, *Building and Environment*, Volume 129, 2018, Pages 117-129, ISSN 0360-1323, <https://doi.org/10.1016/j.buildenv.2017.12.006>.

Pohl G, Nachtigall W (2015) *Biomimetics for architecture and design*. Springer International. Publishing Switzerland, Astudillo, Julen & García, Miriam & Sacristan, Javier & Uranga, Nayra & Leivo, Markku & Mueller, Michaela & Roig, Inma & Langer, Sarka & Gemignani, Gianluca & Vilkki, Markku & Gijzen, Ger & Silva, Susana & Nuñez, Miguel & Dąbek, Michał & Sprenger, Marius & Elgea, Alberto. (2018). New Biocomposites for Innovative Construction Façades and Interior Partitions. *Journal of Facade Design and Engineering*. 6. 10.7480/jfde.2018.2.2104.

RAICO Bautechnik GmbH. (2016). *THERM H-I/H-V Planning Timber curtain wall*. Pfaffenhausen, Germany: RAICO Bautechnik GmbH.

RICS professional statement. (2017). *Whole life carbon assessment for the built environment*. London: Royal Institution of Chartered Surveyors (RICS). doi: ISBN 978 1 78321 208 8

Rothoblaas. (2023, May 18). Rothoblaas.com. <https://www.rothoblaas.com/>

Saint-Gobain North America. (n.d.). Saint-Gobain North America. <https://www.saint-gobain-northamerica.com/>

Shikha Dahiya, Ranaprathap Katakajwala, Seeram Ramakrishna, S. Venkata Mohan (2020), Biobased products and life cycle assessment in the context of circular economy and sustainability. *Materials of Circular Economy*. <https://doi.org/10.1007/s42824-020-00007-x>

Stowa, (2019). *From Biomass to Mycelium Composite, an exploration on Cellulose and Weed Residues Rapport 17*. ISBN 978.90.5773.851.7

Strang, Marcus & Leardini, Paola & Brambilla, Arianna & Gasparri, Eugenia. (2021). *Designing a Durable Multi-storey Cross-laminated Timber Passivhaus Building in Hot and Humid Australian Climates*.

Swedish Wood. Fasteners - Swedish wood. (n.d.). <https://www.swedishwood.com/building-with-wood/construction/fasteners/>

Tapparo A (2017) *Engineered wood glass combination—innovative glazing façade system*. Master Thesis, KTH Royal Institute of Technology. ISBN 978-91-7729-476-4

Verdier, T.; Coutand, M.; Bertron, A.; Roques, C. A review of indoor microbial growth across building materials and sampling and analysis methods. *Build. Environ.* **2014**, *80*, 136–149. [[CrossRef](#)]

Vigener Nik, Brown Mark A. (2016) *Curtain Walls*, Simpson Gumpertz & Heger Inc. <https://wbdg.org/guides-specifications/building-envelope-design-guide/fenestration-systems/curtain-walls>