

Shunt Capacitor Bank Fault Detection and Localization Using Sub-Cycle Algorithm

Tajdinian, Mohsen ; Behdani, Behzad; Goodarzi, Ali; Chamorro, Harold R.; Sood, Vijay K.

DOI

[10.1109/EPEC56903.2022.10000243](https://doi.org/10.1109/EPEC56903.2022.10000243)

Publication date

2022

Document Version

Final published version

Published in

Proceedings of the 2022 IEEE Electrical Power and Energy Conference (EPEC)

Citation (APA)

Tajdinian, M., Behdani, B., Goodarzi, A., Chamorro, H. R., & Sood, V. K. (2022). Shunt Capacitor Bank Fault Detection and Localization Using Sub-Cycle Algorithm. In *Proceedings of the 2022 IEEE Electrical Power and Energy Conference (EPEC)* (pp. 170-175). (2022 IEEE Electrical Power and Energy Conference, EPEC 2022). IEEE. <https://doi.org/10.1109/EPEC56903.2022.10000243>

Important note

To cite this publication, please use the final published version (if applicable).
Please check the document version above.

Copyright

Other than for strictly personal use, it is not permitted to download, forward or distribute the text or part of it, without the consent of the author(s) and/or copyright holder(s), unless the work is under an open content license such as Creative Commons.

Takedown policy

Please contact us and provide details if you believe this document breaches copyrights.
We will remove access to the work immediately and investigate your claim.

Green Open Access added to TU Delft Institutional Repository

'You share, we take care!' - Taverne project

<https://www.openaccess.nl/en/you-share-we-take-care>

Otherwise as indicated in the copyright section: the publisher is the copyright holder of this work and the author uses the Dutch legislation to make this work public.

Shunt Capacitor Bank Fault Detection and Localization Using Sub-Cycle Algorithm

1st Mohsen Tajdinian

Department of Power and Control Engineering,
School of Electrical and Computer Engineering,
Shiraz University
Shiraz, Iran
Tajdinian.M@shirazu.ac.ir

2nd Behzad Behdani

Faculty of Electrical Engineering,
Mathematics and Computer Science
Delft University of Technology
Delft, the Netherlands
B.Behdani-1@tudelft.nl

3rd Ali Goodarzi

Fars Electricity Distribution Company
Fars, Iran
AliGoodarzi69@yahoo.com

4th Harold R. Chamorro

School of Electrical Engineering and Computer Science
KTH, Royal Institute of Technology
Stockholm, Sweden
HR.Chamo@ieee.org

5th Vijay K. Sood

Department of Electrical, Computer and Software Engineering,
Faculty of Engineering and Applied Science,
Ontario Tech University
Ontario, Canada
Vijay.Sood@ontariotechu.ca

Abstract—Fast internal detection and location in Shunt Capacitor Banks (SCBs) can lead to the prevention of damages to other SCBs' elements and consequently avoid undesirable performance and effects in power system operation. This paper targets the performance of phasor-based algorithms of failure detection and fault location of SCBs. Being dependent on the fundamental phasor components which usually are calculated based on the Discrete Fourier Transform (DFT), the failure detection and fault location algorithms suffer from almost one-cycle delay. This paper provides sub-cycle phasor estimation based on the least-square technique. The proposed algorithm is evaluated for different configurations of SCBs considering different fuse protection designs. The proposed method provides a criterion for relay decision-making in the case of multiple faulty phases condition. The proposed method is designed to monitor and detect consecutive failures based on the existing data of commercial relays. Performance evaluations are conducted under different circumstances namely voltage unbalance conditions and multiple internal fault locations.

Index Terms—Fault Detection, Internal Fault, Phasor Estimation, Protection, Shunt Capacitor Banks.

I. INTRODUCTION

The capacitor units, given their wide range of applications in high voltage power systems, are generally protected by various fuse-based protection schemes such as externally fused, internally fused, or even fuseless. Consequently, due to their adequate reliability along with lower costs with respect to their life cycle, the internally fused and fuseless schemes have drawn considerable attention for application in substations [1]-[3]. The internally fused and fuseless schemes, although providing higher accessibility in comparison with the externally fused technology, never-the-less exhibit weakness and have problems in the identification of failed units. According to [4], system imbalance has grown into a common occurrence in power systems, resulting in the necessity of enhanced algorithms for the protection and control systems of shunt capacitor banks (SCBs), enabling the detection of phases and

units with failure. Such enhanced methods should be able to provide fast detection and localization of the failed phases and units, resulting in quick repair and preparation of the SCBs for further operation. Also, these algorithms could be applicable for SCB condition monitoring, therefore helping to prevent unscheduled service outages. It is useful to note that apart from several protection schemes relying on per-phase measurements [1], [5]-[7], due to the inadequacy of the measurements, the conventional unbalance protection functions face issues in localization of faulty unit in SCBs [8].

Through the literature review on the area of SCB fault detection, location, and online condition monitoring emphasizing unbalance protection, only a few studies have been conducted in this area. The previously published literature can be categorized into two main groups of approaches, as explained next. The first group of techniques, utilizing current measurement at the neutral point, are specific to the double-wye SCB topologies [9]-[11]. Employing a current-base unbalance relaying scheme, these approaches can distinguish the faulty phases and the number of failed capacitor units. Reference [9] provided a comprehensive review of the double-wye SCB unbalance protection schemes.

The second group of techniques, being the main interest of this study - relying upon the voltage measurement [12] at the neutral point - focus on the single-wye SCB topologies [13]-[15]. According to [16], these approaches are based on the calculation of the phase angle difference between the reference of the voltage at the neutral point and the positive sequence bus voltage. By referencing the phase angle on the neutral point voltage, the effects of negative sequence voltages are disregarded on the phase angles of the phase voltages. The issue has been solved in the proposed method of [17] for fault localization in single-wye SCB topology, by disregarding the contributing negative sequence in the phase angle reference. The most recently published approach,

proposed in [8], employs the superimposed reactance (SR) concept. The SR approach is based on the application of voltage signals available for unbalanced protection relays. In [18], a comprehensive algorithm was presented that used the coefficients based on capacitor variations to identify the internal faults in the SCB.

With respect to the criteria alluded to in [8], although the SR method shows to be comprehensive in every aspect, there are several defects associated with this method neither being investigated nor put forward. Such issues mainly arise from the protection scheme being unable to perform desirably in case of simultaneous failure of multiple units in different phases, relay operation delay time due to power system transient faults, and the effect of harmonic pollution [19].

This paper investigates the impact of the sub-cycle phasor algorithm on the internal-fault detection algorithms of SCBs. The aim of this investigation is to enhance the speed of element failure detection so that it can quickly identify element failure and prevent SCB's internal damage. The following contributions are provided in the paper:

- This paper utilizes a sub-cycle algorithm based on the least squares technique for phasor estimation to enhance the speed of decision-making in the internal fault detection in SCB.
- This paper can deal with different challenging conditions i.e., unbalanced conditions, and multi-phase simultaneous internal fault scenarios owing to the sub-cycle phasor estimation algorithm.
- The proposed algorithm utilizes the existing data of commercial relays, and it can deal with different configurations of SCBs considering different fuse protection designs.
- Comparing with the state-of-the-art [8] and [18] the proposed algorithm is more efficient in the case of multiple element failure in different units with fault occurrence time less than half-cycle.

The organization of the paper is as follows: *Section II* describes the SCB protection algorithms and requirements of the implementation. *Section III* describes the proposed phasor estimation algorithms. *Section IV* provides different simulation case studies for proposed algorithms and state-of-the-art. Some comments regarding conclusions are given in *Section V*.

II. SCB PROTECTION ALGORITHM

Conventionally, the imbalance protection scheme is used to protect the SCBs against internal faults. However, correct identification of the failure units requires some criteria to distinguish internal faults during multiple failures in different phases of SCB. In the following, the criteria of internal fault detection and faulty phase identification along with a determination of the number of failed elements are provided for different SCB configurations, as shown in Fig. 1 [8]. According to the different SCB configurations shown in Fig. 1, two ratios (so-called K-factors) are defined as follows:

$$K_A \triangleq \frac{C_A}{C_C} \quad (1a)$$

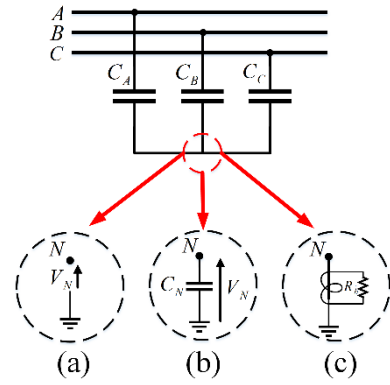

Fig. 1: Configurations of SCB, (a) Ungrounded, (b) Grounded with a grounding capacitor, (c) Grounded with a current transformer.

TABLE I: K_X for Different Types of SCB Configurations

Configuration	K_X
Ungrounded	$K_X = 1$
Grounded by Capacitor	$K_X = 1 + \frac{C_N}{C_C}$
Grounded by CT	$K_X = 1 + \frac{-j}{2\pi f \times R \times C_C \times CTR}$

C_N : Neutral Capacitance

R : Burden of CT

f : System Frequency

CTR : Burden of CT

$$K_B \triangleq \frac{C_B}{C_C} \quad (1b)$$

where C_A , C_B , and C_C are the capacitance of each phase respectively. If the Kirchhoff's Current Law (KCL) is applied at the neutral point, the following expressions are derived:

$$\begin{bmatrix} K_A \\ K_B \end{bmatrix} = \begin{bmatrix} V_A^{re} - V_N^{re} & V_B^{re} - V_N^{re} \\ V_A^{im} - V_N^{im} & V_B^{im} - V_N^{im} \end{bmatrix}^{-1} \begin{bmatrix} V_N^{re}(K_X) - V_C^{re} \\ V_A^{im}(K_X) - V_C^{im} \end{bmatrix} \quad (2)$$

where V_A , V_B , V_C are the fundamental phasor components of the different phase voltages, V_N is the neutral point voltage, subscripts *re* and *im* denote the real and imaginary parts respectively of the phasor components. Also, K_X is the ratio for the different types of SCB configuration, defined in Table I.

A. Criteria for Faulty Phase Identification

According to the definitions of K-factors, several criteria are presented for faulty phase identification for different types of SCB's fuse protection scheme. The criteria are obtained relying on the following two assumptions [18]:

- There are no simultaneous capacitor failures in all three phases.
- Capacitor failure in the internal fused type of SCB will decrease the total capacitance of the faulty phase after the fuse is blown. For fuseless SCBs, the total capacitance of the faulty phase will increase after the fuse is blown. For external fused SCB, the total capacitance of the faulty phase will increase before blowing the external fuse; however, after melting the external fuse, the total capacitance of the faulty phase will decrease.

TABLE II: Criteria for Faulty Phase Detection in Internally Fused SCBs

Faulty Phases	K-factors Variations	Capacitance After Fault
B, C	$K_A^{new} > K_A^{old} \& K_B^{new} \leq K_B^{old}$	$\frac{C_c^{new}}{C_c^{old}} = \frac{K_B^{old}}{K_B^{new}}$ $\frac{C_a^{new}}{C_a^{old}} = \frac{K_B^{old}}{K_B^{new}} \times \frac{K_A^{new}}{K_A^{old}}$
A, C	$K_B^{new} > K_B^{old} \& K_A^{new} \leq K_A^{old}$	$\frac{C_c^{new}}{C_c^{old}} = \frac{K_A^{old}}{K_A^{new}}$ $\frac{C_b^{new}}{C_b^{old}} = \frac{K_A^{old}}{K_A^{new}} \times \frac{K_B^{new}}{K_B^{old}}$
C	if $\{ \frac{K_A^{old}}{K_A^{new}} - \frac{K_B^{old}}{K_B^{new}} < TR_1 \}$	$\frac{C_c^{new}}{C_c^{old}} = \frac{K_A^{old}}{K_A^{new}}$
B, C	$K_A^{new} > K_A^{old} \& K_B^{new} > K_B^{old}$ if $\{ \frac{K_A^{old}}{K_A^{new}} < \frac{1}{TR_2} \times \frac{K_B^{old}}{K_B^{new}} \}$	$\frac{C_c^{new}}{C_c^{old}} = \frac{K_B^{old}}{K_B^{new}}$ $\frac{C_a^{new}}{C_a^{old}} = \frac{K_B^{old}}{K_B^{new}} \times \frac{K_A^{new}}{K_A^{old}}$
A, C	$K_A^{new} < K_A^{old} \& K_B^{new} < K_B^{old}$ if $\{ \frac{K_B^{old}}{K_B^{new}} < \frac{1}{TR_2} \times \frac{K_A^{old}}{K_A^{new}} \}$	$\frac{C_c^{new}}{C_c^{old}} = \frac{K_A^{old}}{K_A^{new}}$ $\frac{C_b^{new}}{C_b^{old}} = \frac{K_A^{old}}{K_A^{new}} \times \frac{K_B^{new}}{K_B^{old}}$
A	$K_A^{new} < K_A^{old} \& K_B^{new} = K_B^{old}$	$\frac{C_a^{new}}{C_a^{old}} = \frac{K_A^{new}}{K_A^{old}}$
B	$K_B^{new} < K_B^{old} \& K_A^{new} = K_A^{old}$	$\frac{C_b^{new}}{C_b^{old}} = \frac{K_B^{new}}{K_B^{old}}$
A, B	$K_B^{new} < K_B^{old} \& K_A^{new} < K_A^{old}$	$\frac{C_b^{new}}{C_b^{old}} = \frac{K_B^{new}}{K_B^{old}}$

Considering the above assumptions, the criteria for faulty phase identification are provided in Tables II and III.

B. Estimating the Number of Failed Elements

The number of failed elements (N_d) is calculated as:

$$N_d = N_e^{old} - N_e^{new} = (1 - \frac{N_e^{new}}{N_e^{old}})N_e^{old} \quad (3a)$$

$$\frac{C_{new}}{C_{old}} = \frac{N_e^{new}}{N_e^{old}} \times (\frac{V_{old}}{V_{new}})^2 \quad (3b)$$

$$N_e^{new} = N_e^{old} - N_d \quad (4)$$

$$N_e^{old} = N_s \times N_p \times N_{us} \times N_{up} \times N_{br} \quad (5)$$

where N_e^{old} is the original number of elements, N_s is the number of series sections in each unit, N_p is the number of parallel elements in unit's series section, N_{us} is the number of unit's series sections per branch, N_{up} is the number of parallel units in unit's series section, and N_{br} is the number of branches in each unit.

III. PHASOR ESTIMATION ALGORITHM

Since the internal unit failure detection in SCB relies on the fundamental phasor components of the neutral voltage, it is mandatory to estimate the phasor from the neutral voltage signal [20]-[28]. In the following, two phasor estimation algorithms including full-cycle Discrete Fourier Transform (FCDFT) and sub-cycle least square (SCLS) technique are presented.

A. Full-Cycle Discrete Fourier Transform

To decide, digital relays require fundamental phasor components of the voltage and current signals. It is assumed that the voltage signal is discretely expressed as follows:

$$v(n) = V \sin(2\pi fnT_s + \alpha) \quad (6)$$

TABLE III: Criteria for Faulty Phase Detection in Externally Fused, and Fuseless SCBs

Faulty Phases	K-factors Variations	Capacitance After Fault
B, C	$K_A^{new} < K_A^{old} \& K_B^{new} \geq K_B^{old}$	$\frac{C_c^{new}}{C_c^{old}} = \frac{K_B^{old}}{K_B^{new}}$ $\frac{C_a^{new}}{C_a^{old}} = \frac{K_B^{old}}{K_B^{new}} \times \frac{K_A^{new}}{K_A^{old}}$
A, C	$K_B^{new} < K_B^{old} \& K_A^{new} \geq K_A^{old}$	$\frac{C_c^{new}}{C_c^{old}} = \frac{K_A^{old}}{K_A^{new}}$ $\frac{C_b^{new}}{C_b^{old}} = \frac{K_A^{old}}{K_A^{new}} \times \frac{K_B^{new}}{K_B^{old}}$
C	if $\{ \frac{K_A^{old}}{K_A^{new}} - \frac{K_B^{old}}{K_B^{new}} < TR_1 \}$	$\frac{C_c^{new}}{C_c^{old}} = \frac{K_A^{old}}{K_A^{new}}$
B, C	$K_A^{new} < K_A^{old} \& K_B^{new} < K_B^{old}$ if $\{ \frac{K_A^{old}}{K_A^{new}} > \frac{1}{TR_2} \times \frac{K_B^{old}}{K_B^{new}} \}$	$\frac{C_c^{new}}{C_c^{old}} = \frac{K_B^{old}}{K_B^{new}}$ $\frac{C_a^{new}}{C_a^{old}} = \frac{K_B^{old}}{K_B^{new}} \times \frac{K_A^{new}}{K_A^{old}}$
A, C	$K_A^{new} > K_A^{old} \& K_B^{new} > K_B^{old}$ if $\{ \frac{K_B^{old}}{K_B^{new}} > \frac{1}{TR_2} \times \frac{K_A^{old}}{K_A^{new}} \}$	$\frac{C_c^{new}}{C_c^{old}} = \frac{K_A^{old}}{K_A^{new}}$ $\frac{C_b^{new}}{C_b^{old}} = \frac{K_A^{old}}{K_A^{new}} \times \frac{K_B^{new}}{K_B^{old}}$
A	$K_A^{new} > K_A^{old} \& K_B^{new} = K_B^{old}$	$\frac{C_a^{new}}{C_a^{old}} = \frac{K_A^{new}}{K_A^{old}}$
B	$K_B^{new} > K_B^{old} \& K_A^{new} = K_A^{old}$	$\frac{C_b^{new}}{C_b^{old}} = \frac{K_B^{new}}{K_B^{old}}$
A, B	$K_B^{new} > K_B^{old} \& K_A^{new} > K_A^{old}$	$\frac{C_b^{new}}{C_b^{old}} = \frac{K_B^{new}}{K_B^{old}}$

where V and α are the magnitude and phase angle of the fundamental phasor component of the voltage signal, f is the frequency of the system and it is equal to 50 Hz, T_s is sampling time, and it is obtained from $T_s = \frac{T}{N}$, where T is fundamental period, and N is the number of samples in one cycle.

FCDFT is conventionally employed in digital relays to extract the fundamental phasor component as follows:

$$V_{Re} = \sum_{n=0}^N v(n) \sin(\frac{2\pi f_0 n T_s}{N-1}) \quad (7)$$

$$V_{Im} = \sum_{n=0}^N v(n) \cos(\frac{2\pi f_0 n T_s}{N-1}) \quad (8)$$

Having real (V_{Re}) and imaginary (V_{Im}) parts of the phasor components obtained by DFT, the fundamental phasor component of the voltage signal is calculated as follows:

$$V = \sqrt{V_{Re}^2 + V_{Im}^2} \quad (9)$$

$$\alpha = \tan^{-1}(\frac{V_{Im}}{V_{Re}}) \quad (10)$$

B. Sub-Cycle Least Square Technique

The previous methods were full-cycle phasor estimation algorithms which means that they require one cycle of data to authenticate the value of the fundamental phasor component. However, the LS technique can extract the phasor component in a sub-cycle. To such an aim, equation (6) can be expanded as follows:

$$v(n) = V \cos(\alpha) \sin(2\pi fnT_s) + V \sin(\alpha) \cos(2\pi fnT_s) \quad (11)$$

To find unknown variables V and α , the equation (11) can be expressed in matrix format as follows:

$$[V_i]_{k \times 1} = [V_s]_{k \times 2} \times [V_x]_{2 \times 1} \quad (12)$$

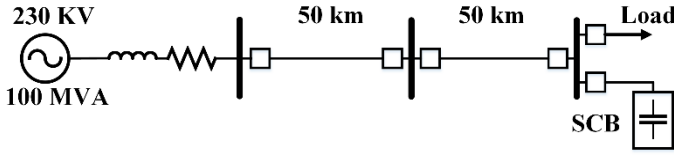

Fig. 2: Test System.

TABLE IV: Elements of the test system shown in Fig. 2

Source Impedance	$Z_1 = 1.5 + j10, Z_0 = 15 + j30$
Line Impedances	$Z_1 = 25.45\angle 85.9^\circ, Z_0 = 68.76\angle 74.6^\circ$
Load	120 MW, 0.9 Lag
Capacitor Bank	70 MVAR

where $[V_i]$ is the voltage samples matrix; signals, $[V_x]$ is the unknown variables matrix, and $[V_s]$ is the known components matrix and are expressed as follows:

$$[V_i]_{k \times 1} = [v(1) \quad v(2) \quad v(3) \quad \dots \quad v(kT_s)]^{TR} \quad (13)$$

$$[V_x]_{2 \times 1} = [V \cos(\alpha) \quad V \sin(\alpha)]^{TR} \quad (14)$$

$$[V_s]_{k \times 2} = \begin{bmatrix} \sin(2\pi f_0 T_s) & \cos(2\pi f_0 T_s) \\ \sin(2\pi f_0 2T_s) & \cos(2\pi f_0 2T_s) \\ \sin(2\pi f_0 3T_s) & \cos(2\pi f_0 3T_s) \\ \vdots & \vdots \\ \sin(2\pi f_0 kT_s) & \cos(2\pi f_0 kT_s) \end{bmatrix} \quad (15)$$

To find the unknown variables in (14), least squares (LS) technique provides fast solution as follows:

$$[V_x]_{k \times 2} = \left[\begin{bmatrix} [V_s]^{TR} & [V_s] \end{bmatrix}^{-1} [V_s]^{TR} \right] [V_i] \quad (16)$$

By calculating $[V_x]$, the fundamental phasor component of the voltage signal is calculated as follows:

$$V = \sqrt{V_x^2(1) + V_x^2(2)} \quad (17)$$

$$\alpha = \tan^{-1}\left(\frac{V_x(2)}{V_x(1)}\right) \quad (18)$$

IV. SIMULATION RESULTS AND DISCUSSION

To assess the effectiveness of the SCLS-based phasor estimation in internal fault detection in SCBs, several case studies considering different conditions are presented in this section. The internal faults contain consecutive element failures in single and multiple phases of SCBs. The required signals of the performance evaluation are obtained from the test system (Fig. 2) which is simulated in MATLAB environment. The test system's specifications are provided in Table IV. As shown in Fig. 2, the test system contains an SCB which is utilized for the evaluation of the different fused-protected configurations of the SCBs. Table V shows the specifications of the different fused-protected configurations of the SCBs.

TABLE V: The SCBs' Specifications

Bank Type	S	P	U_s	U_p	br	$C_{element}$
Internal Fuse	3	14	6	2	2	1.36 μ F
Fuse-Less	6	1	12	1	5	1.36 μ F
External Fuse	8	3	5	14	1	1.36 μ F

TABLE VI: Specifications of Internal Fault Scenarios for Internally-Fused Ungrounded SCB

FIT	0.2	0.35	0.363	0.377
NoFE				
Phase A	2	0	1	1
Phase B	0	1	0	2
Phase C	1	2	1	0

A. Internally-Fused Ungrounded SCB

Table VI provides the internal fault scenarios for an internally fused ungrounded SCB. As can be seen in Fig. 3a, the neutral voltage signal has zero value before internal fault inception. However, after applying the internal fault scenarios in Table V, the neutral voltage signal varies corresponding to the fault severity. As illustrated in Fig. 3a, the fundamental phasor component is estimated by the SCLS-based phasor estimator within 6 ms after the fault inception.

As illustrated in Fig. 3b, while both methods correctly identified the number of failed elements (NoFE) for internal fault at $t = 0.2$ s, it is observed that FCDFT based method fails to detect internal faults after $t = 0.35$ s. This is because it is assumed that there are no simultaneous capacitor failures in all three phases. Since FCDFT requires one cycle data for phasor estimation, the internal fault during $t = 0.363$ s creates a malfunctioning for full-cycle internal fault detection algorithm. However, the proposed sub-cycle phasor estimation correctly tracks the NoFE in a sub-cycle.

B. Fuse-Less Grounded SCB with Capacitor

Table VII shows the internal fault scenarios for a fuse-less grounded SCB with capacitor. As shown in Fig. 4a, the SCLS based phasor estimation algorithm measures the fundamental phasor component with 6 ms delay. Also, as it can be seen in both Figs. 4b and 4c, both algorithms correctly identified the NoFE given in Table VII. The only difference between the two methods is that the proposed SCLS algorithm identifies the internal faults faster than FCDFT.

TABLE VII: Specifications of Internal Fault Scenarios for Fuse-Less Grounded SCB with Capacitor

FIT	0.2	0.35	0.363
NoFE			
Phase A	0	the 2	1
Phase B	0	1	1
SCLS-based2	0	0	

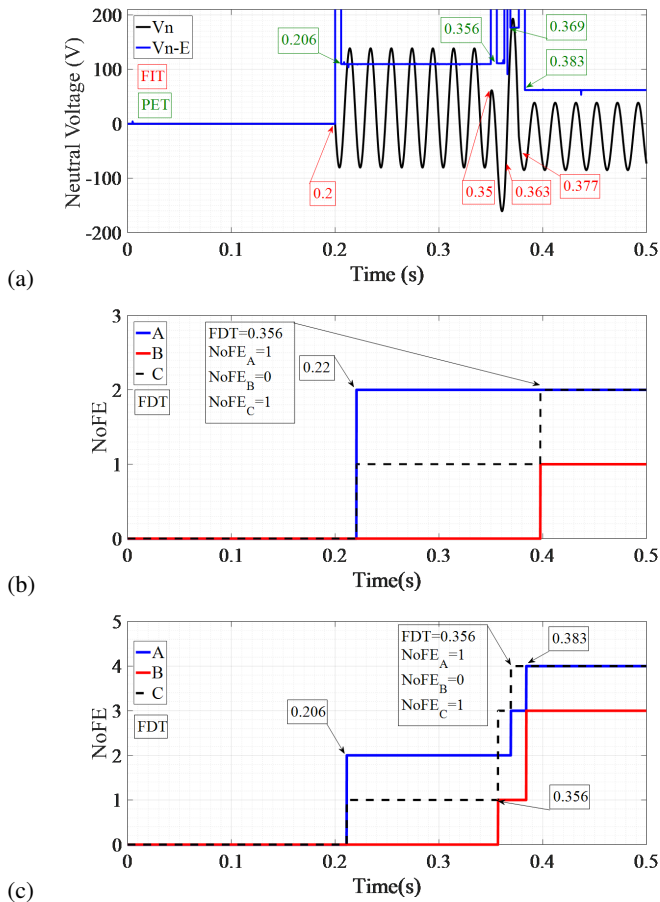

Fig. 3: Performance evaluation of the phasor estimators for internal fault scenarios for internally-fused ungrounded SCB (a) neutral voltage signal, (b) NoFE obtained by FCDFT, (c) NoFE obtained by SCLS.

TABLE VIII: Specifications of Internal Fault Scenarios for Externally-Fused Grounded SCB with CT

FIT	NoFE		
	0.2	0.35	0.36
Phase A	0	2	1
Phase B	3	0	0
Phase C	0	3	0

C. Externally-Fused Grounded SCB with CT

The internal fault scenarios for an externally-fused grounded SCB with CT are tabulated in Table VIII. Like the previous case, the SCLS based algorithm measures the fundamental phasor component with 6 ms delay. According to both Figs. 5b and 5c, while both algorithms correctly identified the NoFE given in Table VIII, the proposed SCLS algorithm identifies the internal faults faster than FCDFT.

V. CONCLUSION

Failure in quick and precise condition monitoring of the SCB's elements may lead to considerable destruction to the SCBs. This paper was dedicated to investigating the performance of

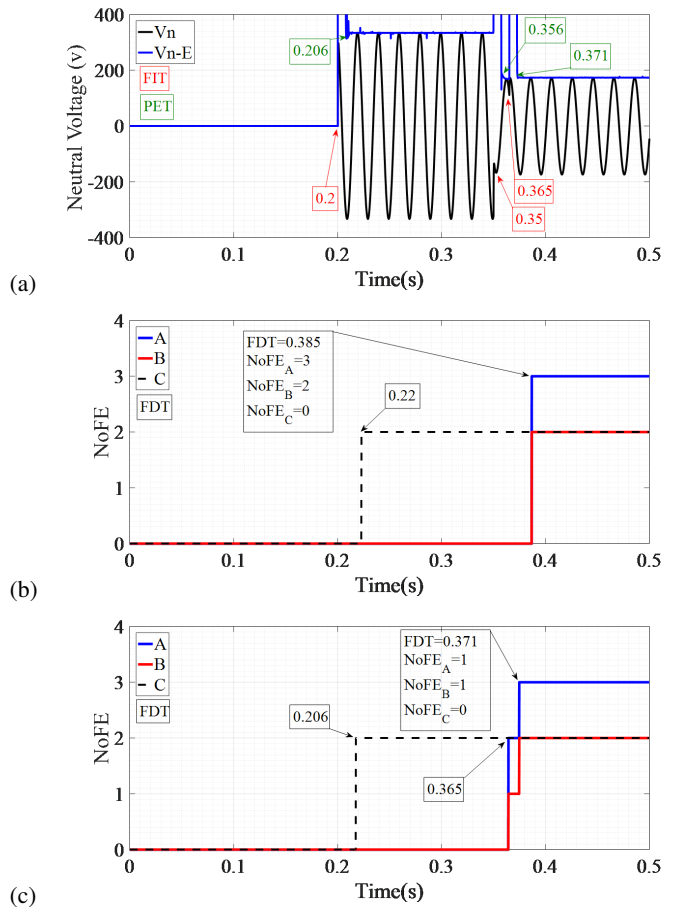

Fig. 4: Performance evaluation of the phasor estimators for internal fault scenarios for fuse-less grounded SCB with capacitor (a) neutral voltage signal, (b) NoFE obtained by FCDFT, (c) NoFE obtained by SCLS.

the sub-cycle phasor estimation for fast online monitoring of the SCBs. To such aim, the fundamental phasor component of the neutral voltage signal was estimated using sub-cycle least square technique. Afterwards, the estimated phasor component was compared with full-cycle DFT to detect the internal fault and to determine the number of failed capacitor units. It was observed that the sub-cycle phasor estimation can detect the internal failures in different fused-protected configurations of SCBs. Also, by employing sub-cycle phasor estimation, capacitor element failures were detected in less than quarter of cycle. Moreover, consecutive failures in less than a cycle which are not seen by full-cycle phasor estimation algorithm, was detected using sub-cycle phasor estimator. Moreover, by employing the sub-cycle phasor estimator, the multiple internal faults in different phases can be detected. As a result, the proposed sub-cycle phasor estimation can be employed to detect the internal faults in SCBs with good accuracy and speed.

REFERENCES

- [1] M. Dhillon and D. Tziouvaras, "Protection of fuseless capacitor banks using digital relays," in *26th Annual Western Protective Relay*

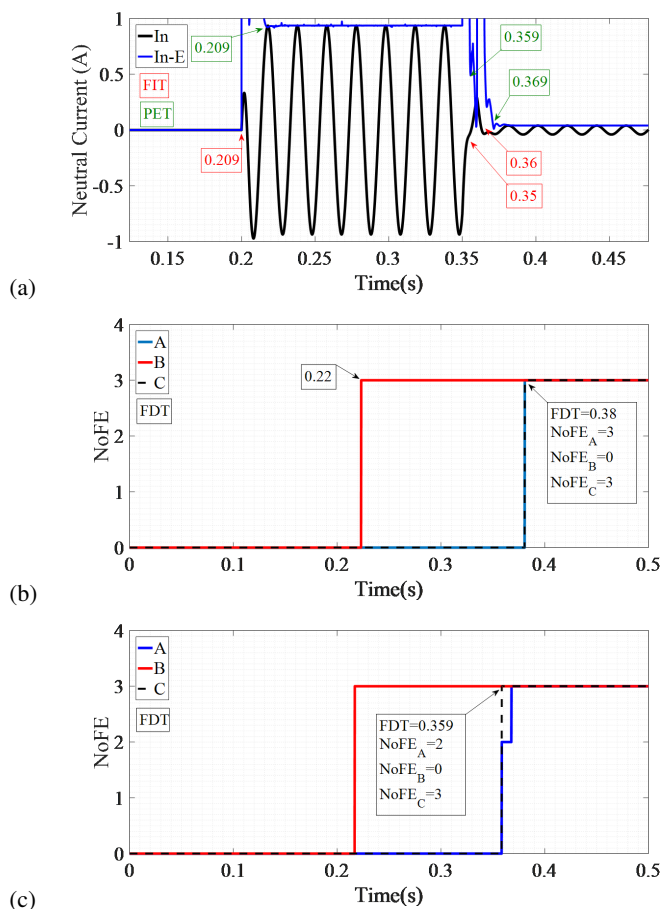

Fig. 5: Performance evaluation of the phasor estimators for internal fault scenarios for externally-fused grounded SCB with CT (a) neutral voltage signal, (b) NoFE obtained by FCDFT, (c) NoFE obtained by SCLS.

- Conference, October 1999.
- [2] B. Behdani, M. Allahbakhshi, and M. Tajdinian, "On the impact of geomagnetically induced currents in driving series capacitor compensated power systems to ferroresonance," in *Int. J. Electr. Power Energy Syst.*, vol. 125, no. 106424, p. 106424, 2021.
 - [3] the *Eaton's Cooper Power Systems catalog: Power capacitors*, Cooper Power Systems, July 2014.
 - [4] K. C. Agrawal, *ewereIndustrial Power Engineering and Applications Handbook*. MA, USA: Butterworth-Heinemann, 2001.
 - [5] M. Bishop, T. Day, and A. Chaudhary, "A primer on capacitor bank protection," *IEEE Trans. Ind. Appl.*, vol. 37, no. 4, pp. 1174–1179, 2001.
 - [6] E. Price and R. Wolsey, "String current unbalance protection and faulted string identification for grounded-wye fuseless capacitor banks," in *65th Annual Georgia Tech Protective Relaying Conference*, May 2011.
 - [7] M. Zhang, J. Du, H. Chang, B. Gao, J. Ma and X. Xiang, "A shunt capacitor detection method based on intelligent substation," in *2017 IEEE Conference on Energy Internet and Energy System Integration (EI2)*, 2017, pp. 1-6.
 - [8] H. Jouybari-Moghaddam, T. Sidhu, I. Voloh, and M. Zadeh, "New method of capacitors failure detection and location in shunt capacitor banks," in *2018 71st Annual Conference for Protective Relay Engineers (CPRE)*, 2018, pp. 1–10.
 - [9] H. Jouybari-Moghaddam, T. S. Sidhu, M. R. Dadash Zadeh, and P. P. Parikh, "Enhanced fault-location scheme for double Wye shunt capacitor banks," *IEEE Trans. Power Deliv.*, vol. 32, no. 4, pp. 1872–1880, 2017.
 - [10] Z. Gajic, M. Ibrahim, and J. Wang, "Method and arrangement for an internal failure detection in a y-y connected capacitor bank," *US Patent 20 130 328 569*, Dec. 2013.
 - [11] S. Raza and M. Ali, "Fault Analysis and Fault location in Fuseless split-wye shunt capacitor banks," in *2019 International Symposium on Recent Advances in Electrical Engineering (RAEE)*, 2019, pp. 1-6.
 - [12] M. Tajdinian, M. Allahbakhshi, B. Behdani, D. Behi, and A. Goodarzi, "Probabilistic framework for vulnerability analysis of coupling capacitor voltage transformer to ferroresonance phenomenon," in *IET Sci. Meas. Technol.*, vol. 14, no. 3, pp. 344–351, 2020.
 - [13] S. Samineni, C. Labuschagne, J. Pope and B. Kasztenny, "Fault location in shunt capacitor banks," in *10th IET International Conference on Developments in Power System Protection (DPSP 2010). Managing the Change*, 2010, pp. 1-5.
 - [14] J. Schaefer, S. Samineni, C. Labuschagne, S. Chase and D. J. Hawaz, "Minimizing capacitor bank outage time through fault location," in *2014 67th Annual Conference for Protective Relay Engineers*, 2014, pp. 72-83, doi: 10.1109/CPRE.2014.6798995.
 - [15] S. Samineni, C. Labuschagne and J. Pope, "Principles of shunt capacitor bank application and protection," in *2010 63rd Annual Conference for Protective Relay Engineers*, 2010, pp. 1-14.
 - [16] B. Kasztenny, J. Schaefer and E. Clark, "Fundamentals of Adaptive Protection of Large Capacitor Banks - Accurate Methods for Cancelling Inherent Bank Unbalances," in *2007 60th Annual Conference for Protective Relay Engineers*, 2007, pp. 126-157.
 - [17] A. Kalyuzhny, J. C. McCall, and T. R. Day, "Corrective device protection," *US Patent 7 973 537*, Jul. 2011.
 - [18] A. Goodarzi, M. Allahbakhshi, M. Tajdinian, and M. Popov, "Multi-criteria protection scheme for online element failure detection in shunt capacitor banks," in *IET Gener. Transm. Distrib.*, vol. 14, no. 19, pp. 4152–4163, 2020.
 - [19] B. Behdani, M. Tajdinian, M. Allahbakhshi, M. Popov, M. Shafiekhah and J. P. S. Catalao, "Experimentally Validated Extended Kalman Filter Approach for Geomagnetically Induced Currents Measurement," in *IEEE Trans. Ind. Electronics*, doi: 10.1109/TIE.2021.3094488.
 - [20] A. Hashemi, M. Tajdinian, and A. R. Seifi, "Probabilistic analysis of current-transformer dimensioning: A criterion for determining the level of exposure to saturation," in *Int. Trans. Electr. Energy Syst.*, vol. 29, no. 4, p. e2786, 2019.
 - [21] M. Tajdinian, A. Bagheri, M. Allahbakhshi, and A. R. Seifi, "Framework for current transformer saturation detection and waveform reconstruction," *IET Gener. Transm. Distrib.*, vol. 12, no. 13, pp. 3167–3176, 2018.
 - [22] M. Tajdinian, A. R. Seifi, and M. Allahbakhshi, "Half-cycle method for exponentially DC components elimination applicable in phasor estimation," *IET Sci. Meas. Technol.*, vol. 11, no. 8, pp. 1032–1042, 2017.
 - [23] M. Allahbakhshi, M. Tajdinian, A. R. Seifi, M. Zareian Jahromi, and A. Bagheri, "Hybrid approach for immunisation of DFT-based phasor estimation method against decaying DC components," in *IET Sci. Meas. Technol.*, vol. 13, no. 2, pp. 238–246, 2019.
 - [24] M. Tajdinian, S. Montaser Kouhsari, K. Mohseni, and M. Zareian Jahromi, "A novel method for decaying DC component removal with regard to frequency fluctuations," *COMPEL*, vol. 35, no. 1, pp. 270–288, 2016.
 - [25] M. Tajdinian, M. Z. Jahromi, K. Mohseni, and S. M. Kouhsari, "An analytical approach for removal of decaying DC component considering frequency deviation," *Elec. Pow. Syst. Res.*, vol. 130, pp. 208–219, 2016.
 - [26] M. Tajdinian, M. Allahbakhshi, A. R. Seifi, and A. Bagheri, "Analytical discrete Fourier transformer-based phasor estimation method for reducing transient impact of capacitor voltage transformer," in *IET Gener. Transm. Distrib.*, vol. 11, no. 9, pp. 2324–2332, 2017.
 - [27] M. Tajdinian, M. Allahbakhshi, A. R. Seifi, and A. Bagheri, "Minimizing the undesirable effect of coupling capacitor voltage transformer on DFT-based phasor estimation method," in *Int. Trans. Electr. Energy Syst.*, vol. 29, no. 1, p. e2672, 2019.
 - [28] M. Tajdinian, M. Allahbakhshi, A. R. Seifi, M. Z. Jahromi, and D. Behi, "Auxiliary Prony-based algorithm for performance improvement of DFT phasor estimator against transient of CCVT," in *IET Sci. Meas. Technol.*, vol. 13, no. 5, pp. 708–714, 2019.