



Delft University of Technology

Resilient Infrastructure and Environment

Spatial operation perspective

Hooimeijer, Fransje; Rizzetto, Francesca; Riches, Federico; Lafleur, Filippo; Chastel, Charlotte; Trinh, Thuy-Trang

Publication date

2017

Document Version

Final published version

Citation (APA)

Hooimeijer, F., Rizzetto, F., Riches, F., Lafleur, F., Chastel, C., & Trinh, T.-T. (2017). *Resilient Infrastructure and Environment: Spatial operation perspective*. Delft University of Technology.

Important note

To cite this publication, please use the final published version (if applicable). Please check the document version above.

Copyright

Other than for strictly personal use, it is not permitted to download, forward or distribute the text or part of it, without the consent of the author(s) and/or copyright holder(s), unless the work is under an open content license such as Creative Commons.

Takedown policy

Please contact us and provide details if you believe this document breaches copyrights. We will remove access to the work immediately and investigate your claim.

This work is downloaded from Delft University of Technology.

For technical reasons the number of authors shown on this cover page is limited to a maximum of 10.

Resilient Infrastructure and Environment 000

Spatial operation perspective

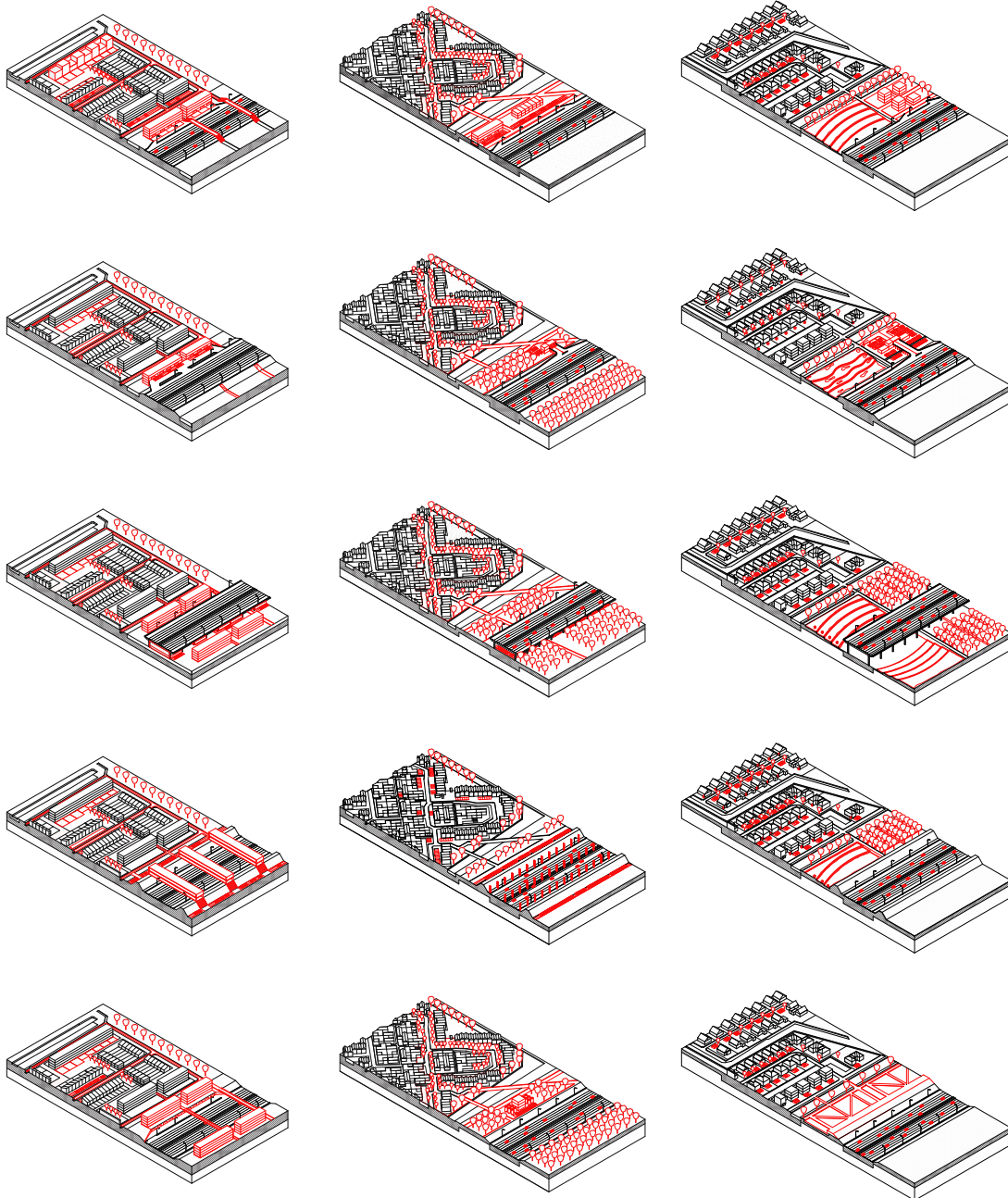

Colophon

Editors:

Fransje Hooimeijer
Francesca Rizzetto

Authors:

Fransje Hooimeijer
Francesca Rizzetto
Federico Riches
Filippo Lafleur
Charlotte Chastel
Thuy-Trang Trinh

Graphic design:

Thuy-Trang Trinh

Delft University of Technology (TUD)

Faculty of Architecture and the Built Environment
Department Urbanism
2628 BL Delft
Postbus 5
2600 AA Delft
The Netherlands

Delft Research Initiative Infrastructures & Mobility (DIMI)

Delft Infrastructures & Mobility Initiative
Postbus 5048
2600 GA Delft
The Netherlands

Delft August 2017

Index

1	<u>Introduction</u>	4
2	<u>Method and approach</u>	5
3	<u>Research</u>	6
	▪ 3.1. West 8 prototypes	7
	▪ 3.2. Urban typologies	10
	▪ 3.3. Application of resilience topics	16
	3.3.1. Gentle Remediation Options	16
	3.3.2. Waste water treatment	23
	3.3.3. Energy	30
	3.3.4. New building programme	38
4	<u>Synthesis & Design</u>	42
	▪ 4.1. Phase 0: The current situation	43
	▪ 4.2. Phase 1: The intermediate phase	47
	▪ 4.3. Phase 2: Highway, buffer, urban area	49
5	<u>Conclusions</u>	60
6	<u>References</u>	62

Spatial planning is the distribution of space, which includes infrastructure planning and area development. In the Anglo-Saxon world, the infrastructure planning and area development are converging to increase the spatial quality and spatial cohesion of the environment, so that the quality of life can be enhanced. 'Regional Development to Infrastructure Provision' (RATIP) is an approach on project-level, in which infrastructure development and area development are intertwined and executed in a certain manner. Uniquely for RATIP is the desirability of creating added-societal value through synergy and intertwinements with other area development projects. It is a rather new and unique concept, which is applied in the Netherlands the projects of the province of Friesland with relatively great success (Cheung, 2014).

The perspective of this investigation takes RATIP into the future by identifying potentials to increase resilience on the relation between the urban field and the highway and the highway itself. This potential is used to anticipate on future technological innovations and ecological improvement of cities in order to be more resilient. This spatial operation perspective is focused on the highway, its buffer and specific urban typologies in the field as one space. Future dynamics offers new trade-offs between these spaces and should take the perspective of the potentials and issues in the field.

There is a growing need for increasing urban resilience to reduce global threats posed by climate change (Solecki, Leichenko, & O'Brien, 2011). Climate extremes are expressed as increased temperatures, sea level rise, more intense rainstorms, droughts, heat waves and secondary effects (Jabareen, 2013; Dopp, Hooimeijer, & Maas, 2011). Consequences of these extremes pose particular threats to urban infrastructure like transport disturbances, higher peak electricity load and voltage fluctuations, increased strain on material and equipment (Wardekker, de Jong, Knoop, & van der Sluis, 2010; Jabareen, 2013).

Cities are resilient when they can tolerate risks, climate extremes, through components and measures that limit the impact, by reducing or counteracting the damage of disturbance, and allow the system to respond, recover and adapt quickly to the risks (Wardekker, de Jong,

Knoop, & van der Sluis, 2010). Resilience is the persistence of relationships within a system and the ability of these systems to absorb changes of state variables, driving variables, and parameters (Holling, 2001; De Bruijn, 2004). This can also be explained as in terms of durability or a stable relationship. A durable material, component or system are adaptable, reusable and durable within its environment, which will be more cost-effective over the whole lifecycle of the system. Therefore, resilience is 'durability plus', or the ability to cope with environmental, economic, functional and political changes.

A 'Resilient Infrastructure' will be those systems of physical assets that will be able to survive and perform well in an increasingly uncertain future. This will need existing physical assets and new assets to become more adaptable. They must be created, designed, built, operated, and / or, disposed of in the light of current as well as new and emergent futures.

Resilience is also a tactical response to the strategic sustainability agenda. For infrastructure systems, the environmental, economic and social impact associated with demolition, disposal and replacement of infrastructure is comparable to the impacts created during its operational lifetime. Similarly, the impacts arising from maintenance, energy consumption, re-engineering and/or re-deployment during the lifetime of an infrastructure system can be very substantial.

Therefore, preserving and extending the effective life of infrastructure, both by enhancing the resilience of existing infrastructure and designing for resilience in new infrastructure, is the best way to maximize its sustainability and help protect our climate, resources and way of life.

2/ Method and approach

The main question of this research is: What is the impact of shifting of the mutual spatial condition between infrastructure and environment on future urban typologies? The method and approach to answer this question is steered by the hypothesis of future technical developments and with a vision of resilient infrastructure. The research is experimental in setting material of different sources together and find synthesis in the design of possible futures.

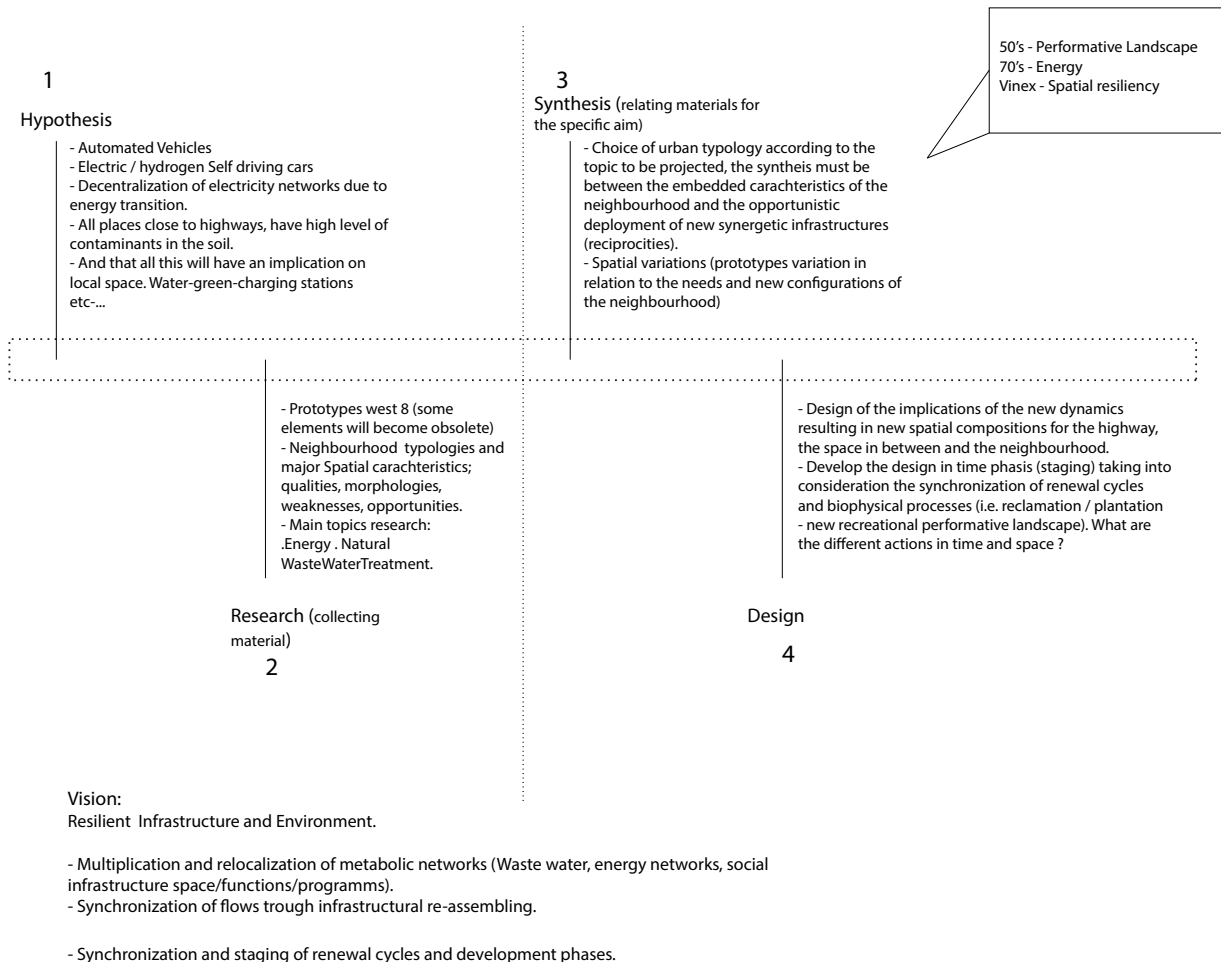

Figure 1
Method of research approach

The research builds on a sequence of steps to clarify and specify the research domain on the one hand and explore new relations to the topic of resilience on the other. First part of defining the research domain was defining the prototypes of highway subject to study and the connection to urban typology.

In 2013, as part of the 'Research to a healthy relation between city and highway', West 8 Urban Design and Landscape Architecture did an inventory and categorization of highways section prototypes throughout the Netherlands. They came up with 11 different prototypes, then studied and compared them in terms of: cost, connections, visual impact, noise and air pollution, and environmental quality. In this study, emphasis is given to the relation of highways with the future urban typologies, more specifically the three selected urban typologies. Therefore, a selection of these prototypes was made on the basis of:

- The future situation: are they affected by the changing conditions on the highway?
- The real time situation: do they occur in relation to the three typologies?

In this way five highway-prototypes, the most likely to meet the two latter conditions, were selected: Floor, Dike, Stilts, Ditch + Dike and Ditch.

These prototypes are related to urban typologies that are situated in the field around the infrastructure line. Contemporary cities are subjected to important changes: demographic, climatic and energetic pressure. To provide inspiration for an approach linking these changes to social and/or spatial tasks and resources in the new future conditions on the highway, 'virtual' samples of urban typologies are used to demonstrate an approach from an integral perspective.

The selection of samples is done on the basis of the Space Mate (Haupt and Berghauser Pont, 2010). The urban types are strongly related with the period in which they are built and thus also have a certain construction typology in itself and a certain relation to the highway. For this project three types are chosen from three different specific periods in time that also are characterized by specific social/spatial issues and another

relation to the highway:

- Post War ('50) car oriented
- *Woonerf* ('70) slow traffic oriented
- VINEX ('90) linked to the highway

The research domain is defined by the combinations of the 5 infrastructure prototypes and 3 urban typologies on which the application of resilience topics is done in the second phase. Main trends that are addressed by the resilience concept are climate change, energy transition and the urbanizing world. There needs to be a mitigating and adaptive response to the changes in the hydrological cycle, a transformation to reduced use of energy and renewable sources, moreover there is less space because of growing numbers of urban inhabitants. In this study the topics of (waste) water, energy and new program are brought in relation to electric cars, automated driving, and the cleaning of the 'old' car use around the highway should be part of the development. For each urban typology the main characteristics and potentials are defined in relation to the topics of (waste)water, energy, remediation and new program.

In the following paragraphs the steps 1) definition of prototypes, 2) definition of urban typologies and 3) the state of the art in the topics natural cleaning, (waste) water and energy are described more closely followed by the synergy found in two phases in which designs are proposed. The report concludes with definition of prosperous new relationships and proposition of research.

3.1. West 8 prototypes

The road network of cities has been largely built in accordance to the demands of different times. Every time generates its own issues: the preoccupations of the Romans who wanted to increase the greatness of their empire, by connecting cities for trade and armies, are far from Cornelis Lely's desire to adapt the state to the upcoming car-dependent society, and even more from nowadays' reflection on reduction of nuisances and energy transition (Calabrese 2004).

Even since the apparition of the modern highways at the beginning of the 20th century, the design of roadways has been regularly updated with new insights, and new structural possibilities appeared. The site-specific topographies combined with these technological advances, led to the existence of a various range of different highway designs (Calabrese 2004).

In 2013, as part of the 'Research to a healthy relation between city and highway', West 8 Urban Design and Landscape Architecture did an inventory and categorization of highways section prototypes throughout the Netherlands. There were 11 different prototypes identified, studied and compared in terms of: cost, connections, visual impact, noise and air pollution, and environmental quality (West 8, 2013).

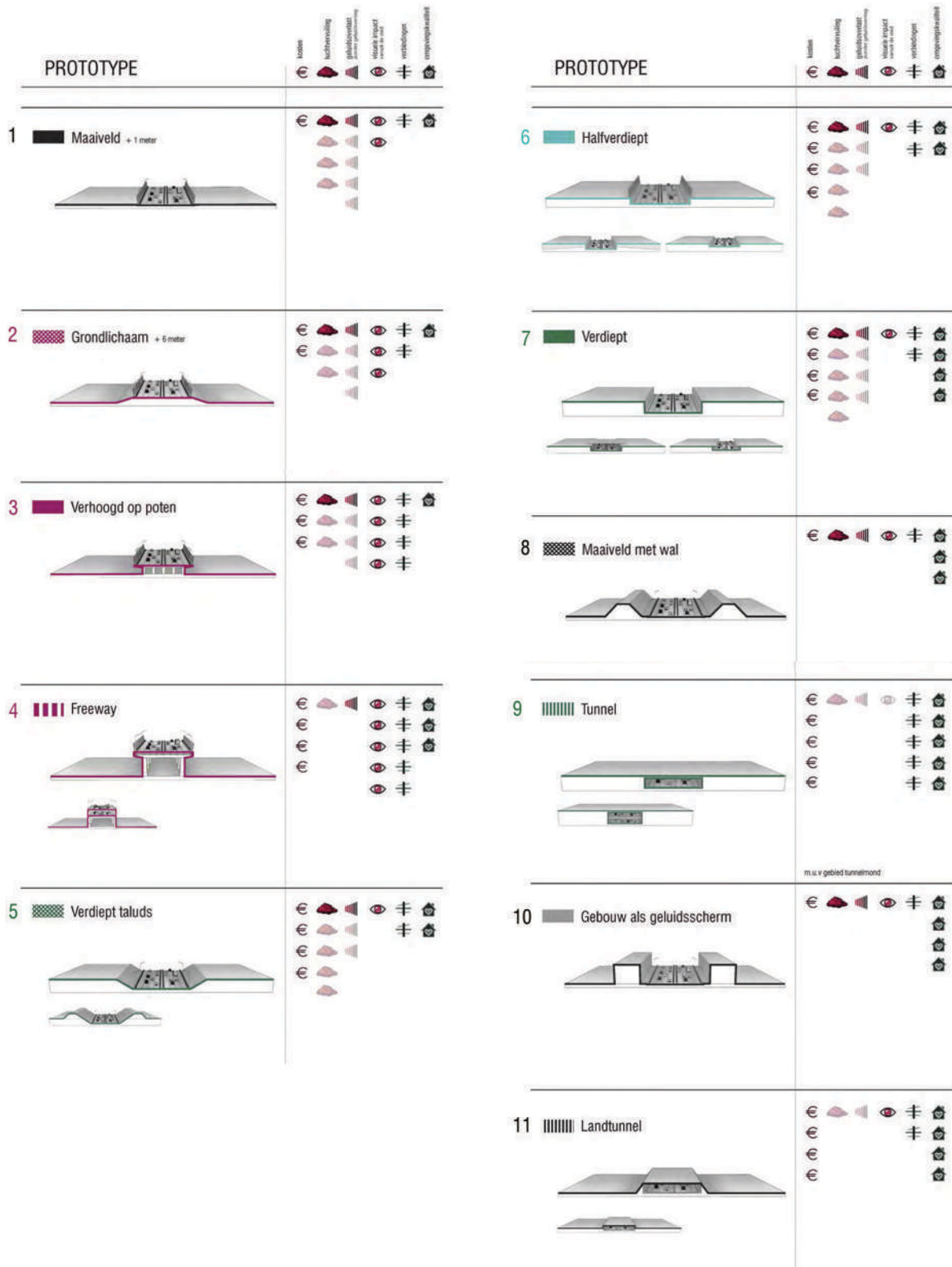

Figure 2
West 8, 2013

To give emphasis to the relation of highways with the urban typologies a selection of the prototypes defined by West 8 was made. The ones that were not selected did not meet the dynamic relation that is foreseen by the new mobility, or were not present in the Netherland, or a unlikely combination with the chosen urban typologies. The five highway-prototypes that were selected are: Floor, Dike, Stilts, Ditch + dike and Ditch. Moreover in this study, these five prototypes will be studied in terms of only the three following characteristics:

- **Connectivity:**
the easiness of the implementation of road connections
- **Visual impact:**
what is the visual effect of the proto-type
- **Spatial quality:**
the extent to which the prototype can satisfy the current and future expectations of the community

Table 1
Overview of spatial characteristics of prototypes
Source: West 8, 2013

	<i>Connectivity</i>	<i>Visual impact</i>	<i>Spatial quality</i>
<i>Floor</i>	Low connectivity: Necessity to build elevated connections (more infrastructure).	Low impact (in absence of barriers): Visual access to the infrastructure but clear view across it.	Low quality: usually covered by a noise barrier. Low pollution (when there are barriers): they reduce the air and noise pollution
<i>Dike</i>	Moderate connectivity: Connections can be built under but necessity to do earthworks to intersect the dikes.	Moderate impact: Visual access to the roadway and no clear view across it. Usually green covered.	Moderate quality: When the dike is covered in green it increases the biodiversity. Low air and noise pollution.
<i>Stilts</i>	High connectivity: Simple ground-level roadways have to be built under it.	High impact: Possible clear view under it but very visible infrastructure.	Low spatial quality: With smart use of this space it can be functional but usually these are very dark and anonymous spaces.
<i>Ditch + dike</i>	Low connectivity: Necessity to build elevated connections and to do earthworks to intersect the dikes.	Low impact: No clear view across, but the infrastructure is hidden behind green embankments.	Good quality: Because of the large buffer zone that guarantees low air noise pollution.
<i>Ditch</i>	Moderate connectivity: Connecting roadways can be built on tope.	Low impact: No visual access to the roadway, clear view above it.	Moderate quality: It is invisible but determining the spatial structure.

These typologies are confronted with the urban typologies to form combinations that then are studied in how they perform in the future mobility modus.

3.2. Urban typologies

Contemporary cities are subjected to important changes: demographic, climatic and energetic pressure increases steadily (College van Rijksadviseurs, 2010). To provide inspiration for an approach linking these changes to social and/or spatial tasks and resources in the new future conditions on the highway, 'virtual' samples of urban typologies are used to demonstrate an approach from an integral perspective (Haupt & Berghauer Pont, 2010). Urban typologies are strongly related with the period in which they are built and thus also have a certain construction typology in itself and a certain relation to the highway. For this investigation three types from three different specific periods in time, with a different combination of social/spatial issues and relation to the highway are chosen:

- Post War ('50) car oriented
- *Woonerf* ('70) slow traffic oriented
- VINEX ('90) linked to the highway



Post War '50s

The urban renewal of Post War areas has been a large spatial project in the past 10 years. During the Post War period 2.149 million homes have been built (CBS, 2010). The quality and size of the housing, plus the design and maintenance of the public space are not meeting the current living standard. Like the large urban renewal of nineteenth century city districts in the 1970s these projects are not merely physical by nature but also have a strong social component. 'Integral approach' is the motto of the policies that steer these urban renewals in which social, economic and physical regeneration are combined. (De Boer, 2010).

The urban renewal focusses on bringing in variety in the housing typologies that is dominated by small, low-cost rental housing. A combination of demolishing buildings and building back ground bound family housing or merging apartments to create a higher segment of housing are strategies to solve also socio-economic and social problems. By bringing in middle and high incomes these projects involve substantial interventions in the urban structure and composition of the population.



Figure 3
Aerial view and standard industrial family houses in Post-War areas
Source: De Boer, 2010

Woonerf '70s

The Third Report on Spatial Planning in 1975 (which eventually led to the more sophisticated version Structure Plan for Urban Areas 1985) promoted the concept of 'concentrated de-concentration'. This concept organizes urban growth in a distributed manner. Smaller towns with growth potentials were identified and appointed to take a share of the projected new housing stock. These towns were in the vicinity of the larger cities such as Alkmaar, Almere, Apeldoorn, Capelle aan den IJssel, Arnhem, Etten-Leur, Haarlemmermeer, Hellevoetsluis, Helmond, Horn, Wood, Houses, Lelystad, Nieuwegein, Purmerend, Spijkenisse, Arnhem and Zoetermeer. Later on the towns more outside the metropolitan area of the Netherlands Groningen, Zwolle, Breda and Amersfoort were added.

This strategy was operationalized in the 'Urbanization Policy Document' (1978). The contribution of these growth centers to the total national projected growth grew by 6.9% in 1972 to 17.8% in 1982. The total housing production of 2,222,533 houses between 1970-1990 is similar to that of the Post War era 1945-1970 (CBS).

Compared to the residential areas of the Post War period the 1970s neighborhoods are still in

good shape. The physical structure of is often highly appreciated: they are green, child friendly and there is plenty of public space. The dead-end, or cul-de-sac car infrastructure of these typical 'cauliflower' urban structures are perceived as unclear. These structures are designed with the focus on the human scale offering quality and security to pedestrians and the reintroduction of nature in the living space. These typical woonerven were connecting public space and front yards in such a manner that the border between public and private property was vague. The backyards were defined as private space. Appropriate budgets for maintaining such a large public green has always been difficult to keep the abundant shrubbery and lawns maintained properly (Van Dorst et al., 2011).

Woonerf neighborhoods are not deprived neighborhoods where ghettoization takes place but are perceived as boring and outdated. The houses are now forty years' old which is the theoretical age at which homes are depreciated for accounting and thus stand in line for reinvestment. Although written off, the houses usually technically good quality but energetically speaking a drama. Many private owners do not reinvest because they cannot save money.

The change rate in house ownership is quite high which makes social cohesion quite low. The most grounded residents are of the first generation residents (the baby boomers) who are now retired and have to ask themselves the question if they can stay or need to move to housing better suited for elderly.

One of the opportunities for this type of neighborhood is to encouraging home ownership (for example convert rental housing to private ownership). Then in a communal maintenance project the housing could be brought up to date. This is necessary to prevent these areas to become the problem areas of the future.



Figure 4
 Typical cul-de-sac urban typology in the 1970s
 Source: Dufour, R. (1979) De recreatieve stad. The Hague: Ministry of Culture, Recreation and Society
 Human scale architecture, family houses in *Woonerf* areas
 Source: Mol, J. (1974) Beverwaard, woongebied voor Rotterdammers. Voordburg

VINEX '90s

The Vierde Nota Extra (VINEX, Fourth Report Extra, 1991), addressed the expansion of towns concerning living, working and recreation. One million houses were planned to 2005; a number that is later readjusted to 600,000. The Fourth Report leads to a whole new urban typology called: VINEX areas, large scale one-size-fits-all urban developments on the outskirts of larger Dutch cities that were solely allocated to housing (Boeijenga & Mensink, 2008). Urban design is done on a city scale. On higher scale planners 'design' the conditions for the new city typology: the network city. The Randstad, an urban conglomeration considered as metropolis, competes with other European and world cities. Economic conditions and living environments can be improved with good infrastructure, good housing and plenty of jobs.

The aim of environmental sustainability within planning is operationalized by making the water issue a leading design principle in the VINEX expansions. In most locations but especially in the locations Leidsche Rijn in Utrecht, Ypenburg in The Hague, Vathorst in Amersfoort and Nesselande in Rotterdam, water was used as an important structuring element (Boeijenga & Mensink, 2008).



Figure 5
Aerial view and standard industrial family houses in VINEX areas
Source: Areoview and Hooimeijer

Concluding, what are the potentials?

In the first two sample urban types '50s and '70s buildings are subjected to intensive maintenance, renovated or demolished and rebuilt. Maintenance means preserving function, which enables residents to remain in the area. Renovation means 'nearly new' where residents have to move out of their house and temporarily live elsewhere. The VINEX type is not subjected to large maintenance or renovation projects, but especially here the vital utilities should be developed in the future.

The following table 2 is summing up the characteristics of the three typologies and their relation to topics of energy, (waste)water and new program.

Table 2

Characteristics of the three typologies and their relation to topics of energy, (waste)water and new program.

Main characteristics	Concepts	Car Infrastructure	Housing blocks	Public space	Subsurface
Post War '50s	<ul style="list-style-type: none"> • 'Neighbourhood Concept' where the city is built up out of units, the smallest unit is the living unit that determines the allotment principle. • Strong and clear idea about what the 'public realm' was to enhance social coherence. • Vague borders between public and private, semi-public and semi-private domain. • Spatial confrontation of open space and mass. 	<ul style="list-style-type: none"> • High accessibility, high connectivity. • Tuned hierarchy in street: ore street, neighbourhood street, living street, living path hierarchy. 	<ul style="list-style-type: none"> • Urban stamp of two or three housing typologies of which most housing slab, revenue houses, collective heating, industrial buildings, rental and social housing. 	<ul style="list-style-type: none"> • Introduction of green structure that is on city and district scale, with more public than private green and more of the same sorts. • Little differentiation. 	<ul style="list-style-type: none"> • Hydraulic filling • Drainage systems • Artificial water system
Woonerf '70s	<ul style="list-style-type: none"> • <i>Woonerf</i> due to strong focus on identity and human scale, <i>gezelligheid</i>. • National urbanizing report allocates expansion of designated cities/ towns. • Ecological revolution 1970s. • Strong aversion for car mobility: flocus on slow traffic. • Re-introduction of water in urban setting as natural spatial element. 	<ul style="list-style-type: none"> • Centre ring street and <i>cul-de-sac</i> system to slow down traffic. • Large hierarchy gap between <i>woonerf</i> and connecting streets. 	<ul style="list-style-type: none"> • Ground bound family houses. • Urban heating. 	<ul style="list-style-type: none"> • Green structures more differentiated. • Smaller scale and more natural (ecology). 	<ul style="list-style-type: none"> • Partial hydraulic filling • Open water structure
VINEX '90s	<ul style="list-style-type: none"> • Large scale national housing programme with projet development driven developments on the outskirts of cities. • Strong different concepts for the urban design. 	<ul style="list-style-type: none"> • Clear street hierarchy. • No <i>woonerf</i> but 30 roads. 	<ul style="list-style-type: none"> • Mixed housing typology. 	<ul style="list-style-type: none"> • Larger green structures for ecology and water. • More private gardens. 	<ul style="list-style-type: none"> • Partial hydraulic filling • Open water structure

<i>Energy infrastructure</i>	<i>Energy potential</i>	<i>Waste water potential</i>	<i>Societal and spatial issues or potentials</i>	<i>Utilities</i>	<i>Solutions</i>
<ul style="list-style-type: none"> • Gas + Electric • Heat + Electric 	<ul style="list-style-type: none"> • Low energy labels of housing. 	<ul style="list-style-type: none"> • Combined system. • Large green surface for higher infiltration rate. • Space for natural cleaning of grey water. 	<ul style="list-style-type: none"> • Variety in housing types too low. • Maintenance issues in housing and public space. • Water quantity and quality issues. 	<ul style="list-style-type: none"> • Usually a centre with services, or close to city centre. 	<ul style="list-style-type: none"> • More ground bound housing. • More defined public space. • More water surface.
<ul style="list-style-type: none"> • Gas + Electric • Heat + Electric 	<ul style="list-style-type: none"> • Low energy labels of housing. 	<ul style="list-style-type: none"> • Combined system. • Infiltration rate high in private in private gardens (if not paved). • High percentage open water. • Space for natural cleaning grey water. 	<ul style="list-style-type: none"> • The <i>woonerven</i> are out of date, housing are not well insulated and use a lot of energy. • Vulnerable for demographic changes. • Unclear public space and infrastructure. • Maintenance of public space is costly and low social cohesion. • No clear identity. 	<ul style="list-style-type: none"> • Usually a centre with services, not so close to the centre. 	<ul style="list-style-type: none"> • Renovation housing. • Redesign public space.
<ul style="list-style-type: none"> • Gas + Electric 	<ul style="list-style-type: none"> • Most housing built with a high energy label or as passive housing. 	<ul style="list-style-type: none"> • Separated system. • High infiltration rate. • Large open water structures. • Space for natural cleaning of grey water. 	<ul style="list-style-type: none"> • Considered as future social-problematic area due to monofunctionality. 	<ul style="list-style-type: none"> • Low number of services, far away from the centre. 	<ul style="list-style-type: none"> • Addition of programme. • Creating communities around resilient topics.

3.3. Application of resilience topics

The perspective of this investigation aims at identifying potentials for increase of resilience of relation between the urban field that aligns the highway and the highway itself. This potential is used to anticipate on future technological innovations and ecological improvement of cities in order to be more resilient. Resilience is the persistence of relationships within a system and the ability of these systems to absorb changes of state variables, driving variables, and parameters (Holling, 2001; De Bruijn, 2004).

The enhancement of a durable or stable relationship can be done by a more distributed approach on which the energy, water and waste cycles are more liked, controllable and closer here will create systems of physical assets that will be able to survive and perform well in an increasingly uncertain future. It offers a tactical response to the strategic sustainability agenda and help protect our climate, resources and way of life. These decentralized and distributed systems are 'open systems' in which nobody has full control on the system itself and more emphasis is put on finding synergy and relation between the parts of the system.

The following topics are investigated and described in the next paragraphs to apply to the synergistic analyses:

- What is the pollution and what are gentle remediation options, to clean the area around the highway?
- What are the spatial dimension of decentral (waste) water treatment, and how can they be utilized in the new spatial conditions?
- What are the spatial dimensions energy (heat and electricity) and how can they be utilized in the new spatial conditions?

The exploration of these topics is quantified on the basis of the urban samples.

3.3.1. Gentle Remediation Options

The environmental impact of roads has been influencing spatial planning regulations for over 40 years (de Boer et al. 2017). Changing to new modes of mobility will also alter these impacts, question is how much and what are the potentials of these new conditions? Anticipating on the changing conditions the hypothesis is that it will be cleaner by using new technology and that remediation of the polluted sites could be done using natural methods, taking advantage of the transition time.

In this paragraph the first question of pollution is investigated and after the possibilities to deal with these with natural resources is explored.

Environmental pollution

Most pollution from traffic routes generally occurs within 10 meters of the route, and thus they can be considered as linear sources. The environmental impact of roads includes the local effects of highways such as noise, water pollution, habitat destruction, local air quality and soil pollution that can be mobile (like metals) or immobile (like chloric). Beyond this: the effect that may include the climate change from vehicle emissions. On the high-speed highways, motor vehicle emissions occur primarily from fuel combustion, fluid evaporation, brake and tire wear, and re-suspended road dust. Vehicles emit a range of pollutants including nitrogen oxides (NO_x) and Particulate Matter (PM). The NO_x main impacts are ozone formation and decreased breathing capacity. PM leads to soiling of buildings and impaired respiratory function. The EU has set limit values for the maximum amount of air pollution citizens should breathe but urban populations are still exposed to levels of NO₂ and PM above these limits, mainly due to passenger cars and vans circulating in these areas.

NO_x comprises a mixture of nitric oxide (NO) and nitrogen dioxide (NO₂). In the air NO is rapidly converted to NO₂ which will also react in the air to form nitrate particles and ozone (O₃). NO₂ is a toxic gas harmful for health. NO_x emissions also contribute to acidification and eutrophication, causing serious damage to ecosystems. Road transport accounts for 40% of NO_x emissions and is the dominant source in urban areas (Source : National emissions reported to the Convention on Long-range Transboundary Air Pollution (LRTAP

Convention) provided by European Environment Agency (EEA)¹.

The average contribution of local traffic to urban NO₂ and PM₁₀ concentrations is estimated at 64% and 34%, respectively. It is estimated that 6-12% of the EU urban population is exposed to NO₂ levels above the EU limit value and that approximately 80% of the urban population is exposed to PM₁₀ levels exceeding the World Health Organization guideline value. (Source: WHO Global Urban Ambient Air Pollution Database)²

The design, construction and management of roads, parking place another related facilities as well as the design and regulation of vehicles can change the polluting impacts to varying degrees. Indeed, the factors that influence on the pollution rate are the number of circulating vehicles, the traffic's speed, the type of vehicles, the topography of the road and the weather conditions. The roadway type itself (design + structure) has a great influence on the amount of emissions. For instance, flat roadways will experience the least amount of resistance to pollutant dispersion. Cut section roads increase the number of vortices created by wind flow, thereby increasing pollutant dispersion. In addition, the roadside topography can help. This includes vegetation, side structures such as noise barriers, and nearby buildings.

¹ <https://www.eea.europa.eu/data-and-maps/indicators/eea-32-nitrogen-oxides-nox-emissions-1/assessment.2010-08-19.0140149032-3>
² http://www.who.int/phe/health_topics/outdoorair/databases/cities/en/

What are the parameters and actual pollutant conditions that need to be considered?

First aspect is the impact distance which is the distance to which higher concentrations are observed at the local geochemical background. Profiles show by decreasing concentrations until the geochemical background is reach, over maximum distances of 80 to 160 m, depending on the pollutants and sites. The results of spot measurements campaigns suggest a rapid decrease of the levels of NO₂ in the first 20 meters of distance from the source, then a gradual reduction with a noticeable influence of the traffic still up to about 150 meters (Airparif, 2008). As for the fallout of emissions, dispersion factors will play an important role. In the case of soil, the age of the infrastructure is also an important factor to consider (Vertigo, 2013).

These pollutants originating from roads and vehicles are deposited on the surface of the road and transported into the local roadside environment by highway runoff and aerial dispersion (short distance aerial dispersion followed by deposition). The latter involves the transportation of material by wind in dry weather, or by vehicle splash and windblown spray in wet weather. Long distance atmospheric dispersion is another major mechanism of transportation, particularly of gaseous and fine particulate material. However, as this impacts mainly on the atmospheric rather than the terrestrial environment, it is not addressed in any detail here.

Table 1 Overview of pollutants originating from roads and traffic and their main sources (adapted from Gupta *et al.*, 1981a; Luker and Montague, 1994, and Leitão *et al.*, 2000)

Type of pollutant	Source of pollution
Heavy metals	Tyres and brake pads, fuel, motor oil additives, rust, crash barriers
Cadmium	Tyres, brake pads
Chromium	Bearing, tyres, brake pads
Copper	Tyres, brake pads, radiators
Lead	Fuel, tyres, brake pads
Zinc	Lubricating oils, tyres, brake pads, crash barriers
Hydrocarbons	Oils, fuels, exhaust emission
PAHs	Fuel, plastics, pavement
Nutrients	Fertilizers, motor fuel & oils, exhaust emission
Organic matter	Vegetation, litter, animal droppings
Salts	De-icing and fertilizers
Microbe	Soil, litter, excreta, livestock movements
Particulates	Tyre, brake & pavement wear, mud & dirt accumulated on vehicles

Table 3
 Leitao T.E. (2005)
 Impact of road runoff in soil and groundwater, Synthesis of Portuguese and other European case-studies
 Lisboa: DHA/LNEC

The compounds emitted come mainly from the fuel combustion, vehicle compounds use, road accessories (like lateral crash barriers) degradation, road degradation, maintenance procedures (application of chemicals), leakage, and accidents.

Characterizations of soil were conducted along roads, where a diffuse pollution is in contact with the ground, but also on the roadside. In the first case the pollutant concentrated stream and carried by runoff is directly in chronic contact with the ground, in the second case it is a diffuse pollution that is in contact with the ground.

In the case of infiltration trench, the impact of the pollution is visible up to 35 cm, while in the undisturbed soil along roadways impact is visible mainly in the first 5 centimetres. This does not negatively impact the groundwater quality, since deposition rates from air are relatively low and the protective effect of the unsaturated zone results in sufficient reduction of concentration. However, where soils have poor buffering capacity, nitrogen oxides that comes with precipitation can influence the quality of surface near groundwater by mobilising metals such as aluminium (Schleyer and Raffius, 2000). Dispersion of traffic pollutants from surfaces into water occurs irregularly and is strongly linked to two factors:

1. Rainfall: at rainfalls of less than 0.5 mm, runoff from impermeable traffic area surfaces generally does not occur.
2. Temperature: at temperatures below freezing, pollutants will not be transported in water.

However, pollutants deposited on surfaces during dry periods or frost accumulate, and the first rainfall or snow melt flushes these substances into the soil or into runoff collection systems) Most pollution from traffic routes generally occurs within 10 meters of the route, and thus they can be considered as linear sources.

When the pollutants have been taken into the soil, then they are considered immobile pollutants because they will not be flowing further into the subsurface like mobile pollutants do.

Gentle Remediation Options

Considering that cars will become cleaner the cleaning of the soils around the highway becomes opportune. When these are immobile pollutants Gentle Remediation Options can be applied. Cundy et al. (2016) define: Gentle Remediation Options (GROs) as risk management strategies or technologies involving plant (phyto-), fungi (myco-), and/or bacteria-based methods that result in a net gain (or at least no gross reduction) in soil function as well as effective risk management. The interest to include this strategy in urban planning and design is twofold: functional and temporal. The spatial effect and functionality of this strategy adds to the green quality of cities. Due to the fact that this remediation method takes more time than old-fashioned methods of excavation, there is the possibility to line up in time the treatment with transformation trajectories in urban development.

In this paragraph the potentials of GRO are explored in relation to the highway pollutants described in the former paragraph.

Table 4

Lexicon of natural treatment methods

Lexicon
<p>Phytoextraction <i>The removal of metal(loid)s or organics from soils by accumulating them in the harvestable biomass of plants. When aided by use of soil amendments, this is termed aided phytoextraction.</i></p>
<p>Phytodegradation / Phytotransformation <i>The use of plants (and associated microorganisms such as rhizosphere and endophytic bacteria) to uptake, store and degrade organic pollutants.</i></p>
<p>Rhizodegradation <i>The use of plant roots and rhizosphere microorganisms to degrade organic pollutants.</i></p>
<p>Rhizofiltration <i>The removal of pollutants from aqueous sources by plant roots and associated microorganisms.</i></p>
<p>Phytostabilisation <i>Reduction in the bioavailability of pollutants by immobilisation in root systems and / or living or dead biomass in the rhizosphere soil – creating a milieu which enables the growth of a vegetation cover. When aided by use of soil amendments, this is termed aided phytostabilisation.</i></p>
<p>Phytovolatilisation <i>Use of plants to remove pollutants from the growth matrix, transform them and disperse them (or their degradation products) into the atmosphere.</i></p>
<p>In situ immobilisation / Phytoexclusion <i>Reduction in the bioavailability of pollutants by immobilizing or binding them to the soil matrix through the incorporation into the soil of organic or inorganic compounds, singly or in combination, to prevent the excessive uptake of essential elements and non-essential contaminants into the food chain. Phytoexclusion, the implementation of a stable vegetation cover using excluder plants which do not accumulate contaminants in the harvestable plant biomass can be combined with in situ immobilisation.</i></p>

Plants for removing metal pollution

From the lexicon of methods for GRO the Phyto-remediation process of heavy metals is lifted out to explain in more details. The capture of the metals is influenced by the pH of the soil, by the redox potential, the content of organic matter, the temperature, the kinetics of the reaction (the magnitude of the transfer of the elements from the solid phase to the liquid and in the roots of plants (Fischerová et al, 2005) by the mineralogy of the soil, from the cation exchange capacity (CEC) (Calaces et al., 2002) and the water content in the soil (which can affect the growth of plants and microorganisms and the availability of oxygen required for aerobic respiration).

Potentially all plants could be used for all inorganic contaminants and some categories of organic contaminants, some of them are more efficient of other with specific pollutants. The term Iperaccumulator has been created by Brooks (1997) to define the plants able to retain more pollutants than others. The best plants to use in Phytoremediation are:

1. *Indian mustard (Brassica juncea L.) Info: Brassica juncea (L.) Czern. - Indian Mustard*

As International Journal of Molecular Sciences has published, heavy metals affect not only industrial sites but also cultivated land, spreading risks for human health. Brassicaceae species are really useful to accumulate certain metals while producing high quantities of biomass in the process, and Indian mustard is the star of this group.

It can remove three times more Cd than others, reduce 28% of Pb, up to 48% of Se, and it is effective against Zn, Hg and Cu as well. However, what is unknown is that Indian mustard removed radioactive Cs137 from Chernobyl (Phytoremediation of Radiocesium-Contaminated Soil in the Vicinity of Chernobyl, Ukraine) in the 80's as well.

2. *Willow (Salix species). (White Willow)*

The water loving plants beautify landscapes, however, it's worth is not confined to its appearance only. They have a more interesting use for phytoremediation as well: their roots have demonstrated (Response of *Salix alba* L. to heavy metals and diesel) viability, accumulating lower levels of heavy metals than Brassicaceae, and they deal with Cd, Ni and Pb, and work even in mixed heavy metals like diesel fuel polluted sites.

Westergasfabriek Park in Amsterdam, which LAN talked about in the article Westergasfabriek Park Goes from a Polluted Gas Factory to an Award Winning Design by Gerard De Silva.³ It shows recreational and remediation features of willows through ponds and aquatic gardens. Large-scale systems for urban waste water are also effective, as the Swedish projects mentioned in Willows for energy and phytoremediation in Sweden do (Dimitriou and Aronsson, 2005).

3. *Poplar tree (Populus deltoides). (Populus deltoides W. Bartram ex Marshall eastern cottonwood)*

The advantageous effect of poplar trees on soil and underwater has also been widely studied. Their secret lies in the naturally well-designed root system which take up large quantities of water. Chlorinated solvents such as trichloroethylene, or the well-known carcinogenic carbon tetrachloride (95% of substance removed) are the organic pollutants that hybrid poplars face better, according to research from National Institute of Environmental Health Sciences (2015).

What is more, PhytoPet (Bioremediation of Aquatic and Terrestrial Ecosystems), the Canadian database for bioremediation methods, remarks that poplar trees can degrade petroleum hydrocarbons like benzene, toluene and o-xylene. Although they are not very common in public gardens, you have one sample of poplar tree integration in this interesting LAN article, The Sensational Hive Project by World Renowned Grant Associates written by Erin Tharp (2015).

³ <https://landarchs.com/westergasfabriek-park-goes-from-a-polluted-gas-factory-to-an-award-winning-design/>

4. Indian grass (*Sorghastrum nutans*)
(*Sorghastrum nutans* (L.) Nash)

Research looked at how this Midwestern U.S. native plant benefits soil and ground water around them (Henderson, Belden, Zhao and Coats, 2006). Many people can find Indian grass growing along the roadsides without noticing its power to detoxify common agro-chemical residues such as well-known pesticides and herbicides related to atrazine and metalochlor.

Indian grass is one of the nine members of the gramineae family identified by PhytoPet (Bioremediation of Aquatic and Terrestrial Ecosystems), as capable to remediate petroleum hydrocarbons. The list includes other grasses like Common buffalo grass or Western wheatgrass, leading the ranking.

5. Sunflower (*Helianthus Annuus L.*)
(*Helianthus annuus* L. common sunflower)

Experiments like Influence of the sunflower rhizosphere on the biodegradation of PAHs in soil (Polycyclic Aromatic Hydrocarbon like petroleum oil contaminating the environment) reveals that sunflowers reduce different PAH level from soil, in an effective way, but what is really surprising is how varied range of contaminants they can accumulate.

Heavy metals such as Pb, Zn (Heavy Metals Extraction Potential of Sunflower (*Helianthus annuus*) and Canola (*Brassica napus*)), N, P, K, Cd, Cu or Mn (Capability of Heavy Metals Absorption by Corn, Alfalfa and Sunflower Intercropping Date Palm), seem to be its food, which is great news because sunflowers have a quick growth to start working soon.

In fact, one month old plants reached the incredible goal of removing more than 95% of uranium in 24 hours, (sunflower (*Helianthus annuus* L.) – a potential crop for environmental industry) which shows their power to remove radioactive metals, including Cs and Sr from superficial underground water. When reinforcing the effect of sunflowers with other species, it seems highly successful for many sites, for example waste mining sites (Tejeda-Agredano, Galleco, Vila, Grifoll, Ortega-Calvo and Cantos, 2013).



Figure 6
1. Indian mustard (*Brassica juncea* L.)



Figure 7
2. White Willow (*Salix* species).



Figure 8
3. Poplar tree (*Populus deltoides*).



Figure 9
4. Indian grass (*Sorghastrum nutans*)



Figure 10
5. Sunflower (*Helianthus Annuus* L.)

To anticipate on the landscape typology there is the choice for woody or aquatic plants to use for phytoextraction. Compared to herbaceous species, woody ones have the advantage of exploring with the deeper layers of the soil root systems. The Salicaceae, Poplar and Willow in particular, are the most promising arboreal plants for use in phytoextraction due to:

- fairly high concentration of metals;
- fast growth;
- deep root system.

Aquatic plants phytoextraction that are particularly suitable are:

- Eichhornia crassipes (Water hyacinth)
- Hydrocotyle umbellata
- Lemna minor
- Azolla pinnata
- Eichhornia crassipes

22

All of these species are capable of absorbing Pb, Cd, Cu, Fe, Hg.

On the base of the rough inventory on type of pollution and methods for cleaning solid the following diagram is made to support design with this knowledge.

Table 5
Performance diagram

Name	Type	Quantity in 1 m ²	Time (years)	Biomass production	Metal
Indian Mustard	Plants	44	0.12 (45days)	350 g/m ²	Cd,Pb,Se,Zn, Hg,Cu
White Willow	Trees	1	6 (Zn) 20 (Ni) 15-50 (Cd)	200 g/ m ²	Cd, Ni,Pb, Zn
Poplar Tree	Trees	1,5	6	430 g/m ²	Chlorinated solvents, carcinogenic carbon
Indian grass	Plants	9	1	720 g/m ²	petroleum hydrocarbons
Sunflower	Plants	49	1	750 g/m ²	Pb, Zn, N, P, K, Cd, Cu, Mn

3.3.2 Waste water treatment

Clean water is one of the world's most precious resources, yet it is under a continuous threat because of the climate change (more specifically the resulting drought) and the tremendous growth of population, requiring fresh water and producing more polluting discharges. The severity of surface water pollution is a worldwide and priority problem, since water scarcity has been increasing everywhere and may become in many countries absolute by the year 2025 (Lalad, 2007). Thus, we must endeavor to more efficiently manage our limited sources of water. One of the most promising action to cope with the global water crisis is the municipal water reclamation and reuse (Chu et al., 2004).

The current urban wastewater management systems are linear systems based on disposal. Many different technologies for wastewater reclamation exist, but they are generally based on highly optimized mechanical, chemical and microbial processes (Brix, 1999). What is more, traditional technologies are also known to consume large amounts of energy and chemicals for the treatment process (Oswald, 1995). For these reasons, they cannot be considered as the most sustainable solutions. Therefore, recent years have witnessed a major shift in the approach to wastewater treatment, from high-tech technologies to environmentally sound, sustainable, low-cost and effective solutions based on ecological principles, namely Ecological or Natural systems (or Technology, Saha and Jana, 2003).

Natural treatment systems are engineered systems that have a limited dependence on mechanical and chemicals elements to support the treatment process, instead using natural processes (bio-geochemical activities in the natural ecosystems like plants, soil and bacteria) to break down and neutralize the pollutants in wastewater. For a process to be sustainable, it should also maintain and promote biodiversity, renewability over time (Office of Bio Renewables Programs 2008). Precisely, natural systems are based on a systemic strategy, generally promoting a closed-loop urban wastewater management including the preservation of:

- the water itself: indeed, the environmentally-sound attributes of these systems are ability to offer recovery and reuse of the water, rather than dispose of it.

- and the nutrients inside of it: for instance, in aquatic ecosystems nutrients in nitrogenous and phosphorous compounds are recycled into usable biomass by means of the ecological food chains (De Pauw and Salomoni, 1991).

Besides, they require limited energy to operate as processes occur naturally, and they produce lower amounts of excess sludge which is often treated at high energy – and thus economic – cost. Therefore, they can clean contaminated water in a low cost and low impact manner, and can be designed to have a long and renewable life. To address the biodiversity issue, some ecological systems can provide a habitat for wildlife (Knight et al. 2000).

In addition, natural systems for wastewater treatment can contribute to the urban quality. In contrast to the conventional technologies that are mainly constructed of concrete, the ecological technology involves the establishing of green areas and/or water bodies, which can improve the visual quality, increase the recreational opportunities, mitigate the Heat island effect increased by climate change, and create environmental education (Gearheart and Higley 1993).

Natural waste water treatment

Appropriate technology unit processes include the following (in increasing order of land/water proportion):

- High-rate infiltration fields
- Overland flow systems
- Constructed wetlands
- Waste stabilization ponds or lagoons

This investigation concentrates on engineered wetlands as the main alternative to conventional wastewater treatment. Their principles involve causing water to flow through a gravel filter on which macrophyte plants (aquatic plants) are grown. Their roots carry oxygen to the soil and create an environment conducive to the development of water-purifying micro-organisms. In some way, the process reproduces the natural water purification process in marshes in which row water begins to settle by discharging its solid particles and then undergoes natural physical, chemical and above all biological treatments favored by aquatic plants.

Constructed Wetlands

Constructed wetlands are natural systems in which the wastewater flows through a planted soil filter where the biological and physical treatment takes place. They combine most of the benefits of natural systems mentioned above: little use of energy, attractive landscape, wildlife habitat creation, low sludge generation, low cost, and recreational and educational uses (Pötz & Bleuzé 2012). Here the choice of Constructed Wetlands is mainly founded by special spatial opportunities provided by the presence of the highway. Indeed, in general, very few examples exist of the application of constructed wetlands for wastewater treatment in regular urban areas.

The main explanation is the large surface that is required for an efficient treatment, and area is often lacking in dense urbanized conditions, or is very expensive, which would absorb the other cost savings of constructed wetlands. Therefore, Constructed Wetlands are often limited to less densely populated peri-urban areas where more land is available and costs less. In our case, thanks to the buffer zone between the urban tissue and the highway, we can use a significant amount of space for wastewater treatment.

Another important limiting factor is the acceptance by the community, due to the common belief that wetlands are a home for mosquitos and bad smells. If the risk is significant, it can however be prevented in sub-surface flow wetlands, with an appropriate design (correct choice of filtering material and dimensions to avoid an above-ground water flow) which require more space but is possible in our study case. And besides, as mentioned above, a benefit of Constructed Wetlands is that they can be incorporated into urban amenities, in a park for example. In this configuration, serious attention should be given to avoid direct contact between humans and the wastewater loaded with pathogens.

This follows the idea of constructing multifunctional urban landscape infrastructure which involves nature based performance or performative assets, which becomes infrastructure in the sense that they contribute (generate and support) urban economies and urban life.

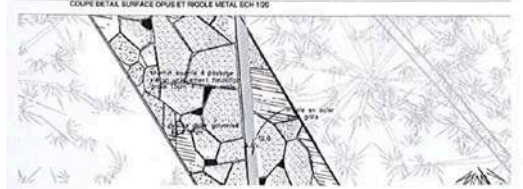
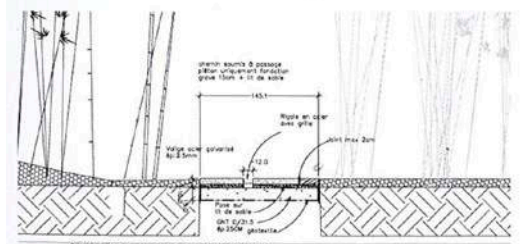
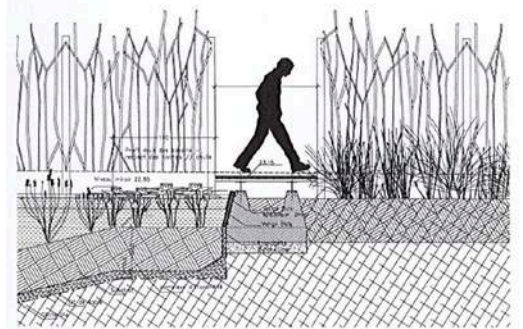
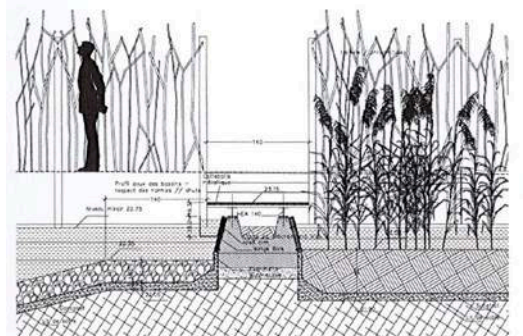

Figure 11

Garden of Giants, Lille 2009, Duncan Lewis Scape Architecture
Source: Sponge City: Water resource management (2015)

Table 6
Performance Diagram
How much you clean per m² or household in time:

	Treatment	Quantity	M2/ household mm/m2 m3	Uses after cleaning
Rain water	Horizontally flooded stream (HF) and Free Flow Fructification (FWS)	765 mm/year (NL data)	100%+ 30% evaporation	washing water, cooling water, irrigation, fire protection
Grey	Horizontally flooded stream (HF)	47 L/pers./day	100% of grey water produced	Irrigation, refilling WC flushing cisterns, firefighting, floor washing
Black	Purification and filtration centre	37 L/pers./day	44% of black water produced	refilling WC flushing cisterns, cooling towers

* Sources:

<http://www.irdra.eu/it/fitodepurazione/applicazioni/acque-meteoriche-2.html>; <http://www.yourhome.gov.au/water/wastewater-reuse>;
https://books.google.nl/books?id=KKZMp2kotAEC&pg=PA281&lpg=PA281&dq=phytodepuration+black+water&source=bl&ots=zv3YD4Qghr&sig=FvwCjIRIU4N_HG3PIIXb63pYGVc&hl=it&sa=X&ved=0ahUKewiGksK9gN7UAhVEELAKHVxjCSgQ6AEIMDAB#v=onepage&q=phytodepuration%20black%20water&f=false; <http://www.ilnuovocantiere.it/gestione-delle-acque-per-prevenire-il-rischio-idraulico/>;
http://www.irdra.eu/it/?option=com_content&view=article&layout=edit&id=101

Table 7
Performance diagram GRO

	Available space: buffer, open public spaces and private gardens**	Amount of space available so how many households can you serve (0,5 - 1m ² /inhabitant for Aerated verticale helophyte filter*.)	Amount of space available so how many households can you serve (vertical helophyte filter*: 2,5 - 5m ² /inhabitant)	Inhabitants (Average household: 3,7 inhabitants/house)
1950's	11510 m ²	136.9-273.8 m ²	684.5 -1369 m ²	273.8
1970's	25029 m ²	259-518 m ²	1295 - 2590 m ²	518
1990's	27566 m ²	157.25-314.5 m ²	786.25 - 1572.5 m ²	314.5

* for every individual, a minimal of approximately 2,5 m² helophyte required. The effectiveness of the helophyte filters can be increased by adding more oxygen to the roots. This reduces the needed space, down to only 0,5m² per individual but it increases the maintenance and the long term

helophyte filter: 2,5 - 5m²/inhabitant. Aerated vertical helophyte filter: 0,5 - 1m²/inhabitant

** dimensions extracted from the samples, the Available space comprehends: buffer, open public spaces and private gardens, but suggestion is to use the buffer space, as a continuous available space. (Masi, Rizzo, Bresciani, Conte 2017)

Technical interventions on the smaller scale

Various technological developments in drainage and water management on the smaller scale steer the achievement of the defined spatial issues in the urban samples. These technical innovations redefine the spatial configuration of delta cities. In the research project: Intelligent use of subsurface infrastructures for surface qualities (Hooimeijer et al., 2016), these techniques were explored and projected onto urban landscape transformation pathways. Following the research by design and spatial implications deployed in the aforementioned project, here below, these methods and innovations are related to their applicability or suitability in the different spatial compositions of the three typologies. In doing so, they become active agents that permit the spatial objective to be achieved through their deployment in existing urban and landscape settings. In this sense they act as facilitator, contributors or tools to achieve new building program, decentralize waste water treatment and distributed energy networks.

Table 8
Applicability to the urban typologies

	Flexible pipes	Helophyte filters	Infiltration crates	Smart Piping	Soseal	Source separation
1950's	+	-	+	++	-	-
1970's	+	-	++	+	-	+
1990's	-	++	-	+	++	++

++ good
+ moderate
- difficult

Flexible pipes

This technology is about organic waste separately distributed with waste water through flexible pipes. Open up opportunities to create local sewage treatment plant, smaller sewage community systems. Increasing the resilience in terms of the diversification of the urban program. Moreover, going toward the construction of 'next generation infrastructures' (Brown, 2014) at the intersection between infrastructural performance and recreational, communitarian services.

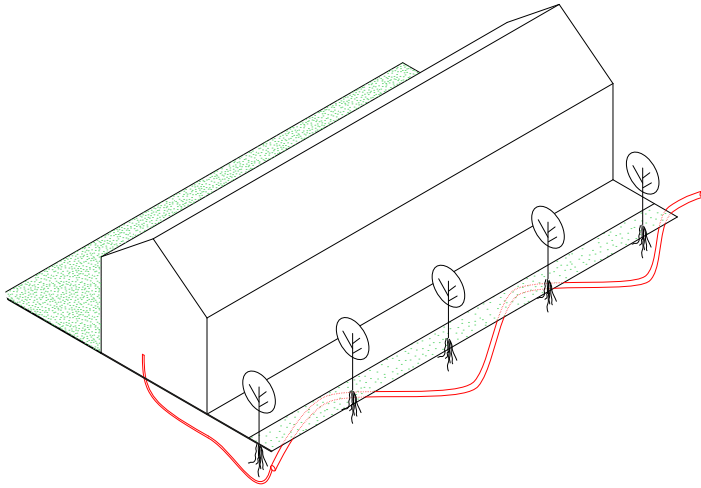

Figure 12
Influence of flexible pipes on the urban structure and design of public space.

Helophyte filters

This technology is about the Natural cleaning of water. It could be deployed to strategically unloading sewers by adding natural qualities to the built environment. The re-naturalization of open water systems must take into consideration potential threats for urban health (e.g. insects/ disease proliferation). Eventually, in relation to urban structures this technology must be located in proximity to existing underground drainage and open water system.

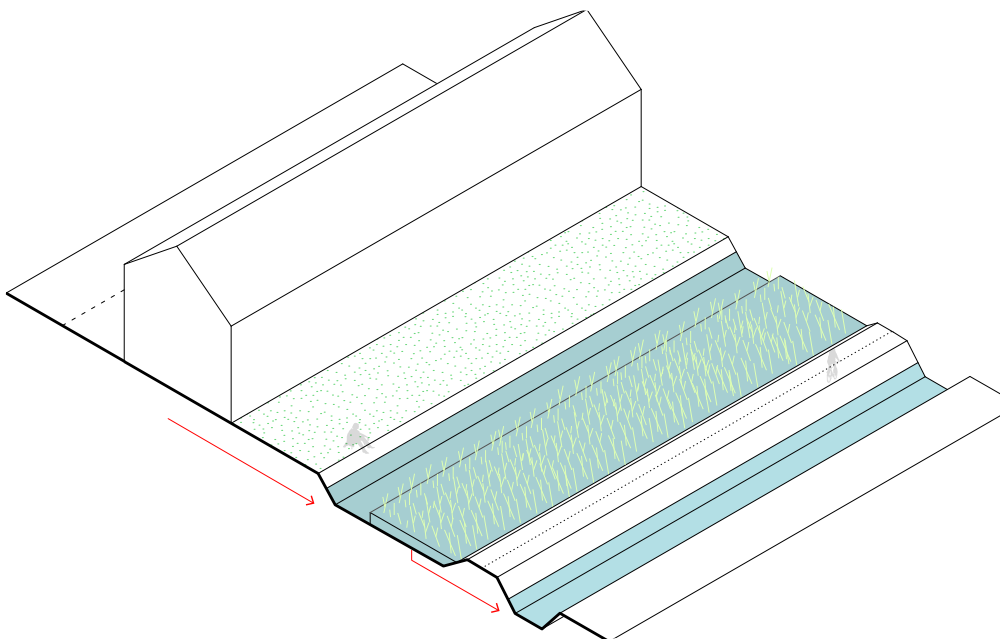

Figure 13
Influence of helophyte filters on the urban structure and design of public space.

Infiltration crates

This technology allows for an increased performance in the urban water system by harvesting Rainwater in crates under streets. The reclaimed water unloads the capacity of the sewer thus making it more resilient as well as reusing water for irrigation.

Furthermore, the technology allows for a more efficient use of space making design of public space in areas where spatial conflicts might occur due to the local manifestation of multiple infrastructural assets.

Therefore, it becomes instrumental in projects of densification of roads and infrastructures in the city.

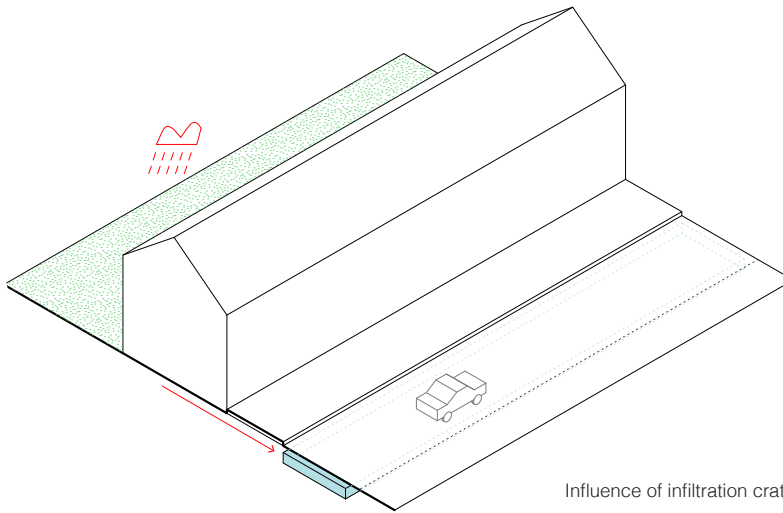

Figure 14
Influence of infiltration crates on the urban structure and design of public space.

28

Soseal

This technology is about the impermeabilities of soil. It allows for the creation and projection of smaller scale water units where water is treated temporarily thus maximizing the efficiency in pollution control as well as stopping the spreading of contaminants in the subsurface.

Eventually it permits the formation of short term water infrastructures for flexible development phasing and transitions.

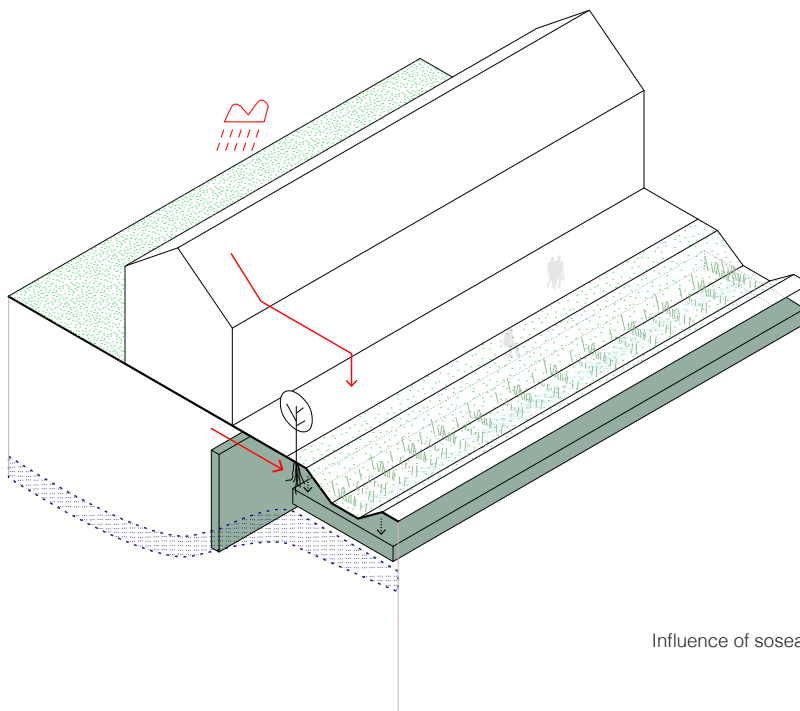

Figure 15
Influence of soseal on the urban structure and design of public space.

Source separation

This technology is about the synchronization of different waste flows by separating households output, thus the 'waste' becomes a source, i.e. input for local sewage treatment plant. As for flexible pipes technology this allows for the creation of decentralized network of public - private infrastructures. Eventually, the materialization of this new systems can be integrated in public program where infrastructural performance and multi-functionality coexist.

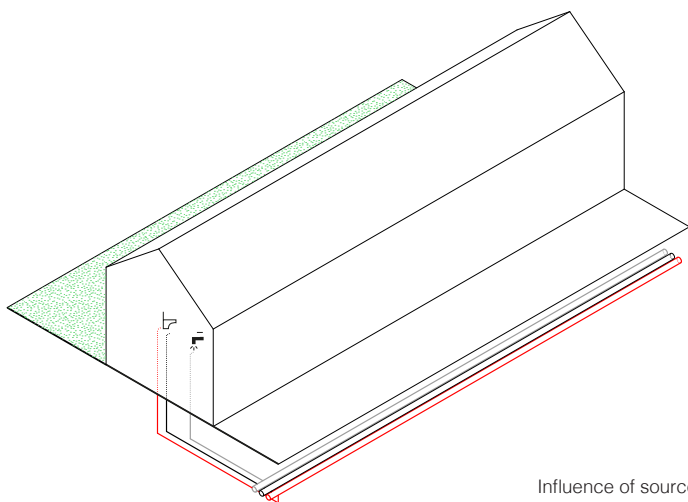

Figure 16
Influence of source separation on the urban structure and design of public space.

Smart Piping

This technology is about the creation of new system for urban water management. The projection comes in the form of hybrid civil, hydraulic and landscape elements carefully composed for the maximum performance benefits as well as spatial qualities.

Reliant on a new culture of water management works and the availability of road infrastructures to be retrofitted in the light of paradigm shifts, these systems advocate for the renewal of public infrastructures as a new surface connective tissue for the urban landscape.

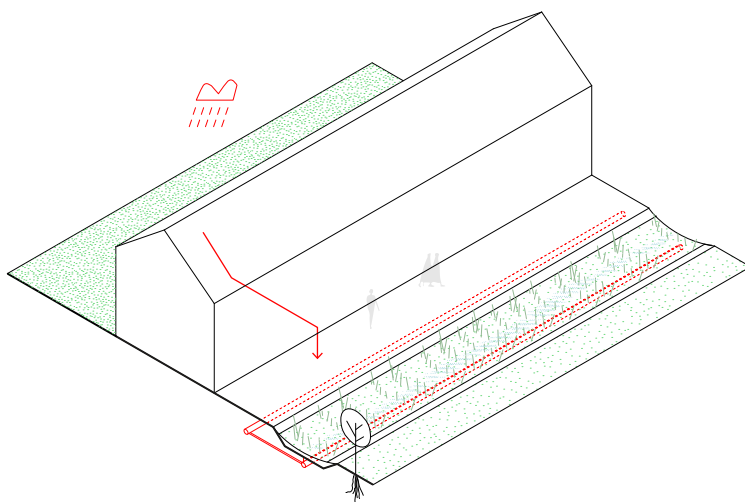

Figure 17
Influence of smart piping on the urban structure and design of public space.

3.3.3. Energy

In the Netherlands the main focus to provoke an energy transition has been to reduce the energy consumption of individual homes and buildings. This usually occurs on the basis of the so-called Trias Energetica (Lysen 1996, Van den Dobbelsteen, 2011 ; Sijmons 2014), an approach through the three successive steps:

- **Step 1:** Reducing energy demand by insulation of buildings and heat recovery from ventilation air and shower water,
- **Step 2:** Use of renewable energy like wind, solar, biomass or geothermal energy,
- **Step 3:** Efficient use of fossil fuels by high conversion efficiencies.

The Trias Energetica is a practical guide that by constrains of practical and/or economic nature could be interpreted differently. In almost all cases it is better to reduce energy demand prior to the deployment of renewable energy; both in terms of achieving energy savings and to achieve durability as from the viewpoint of cost. This is because the price of renewable energy converters and storage is (still) high. The fixed capacity costs of wind turbines and photovoltaic solar panels are high, while the source is mostly free. This is the opposite to conventional fossil energy converters like natural gas-fired power plants. Reducing the heat demand of housing - for example, from 15 kW to 2 kW or lower in -10C outside, such as passive houses - not only provides a significant energy savings, but also a reduction of capacity demands on gas-fired power plants; thus a great saving on investments. Therefore, the reduction capacity (kW) in an area with passive houses is worth much more than in an area with classic fossil energy.

In existing urban areas, the transition to sources of renewable energy (solar, wind, biomass) is more difficult because these use more land surface (H+N+S, 2008). Because of this fact and the costs, Trias Energetica is more applicable to areas with sustainable energy than for areas with conventional energy. Reduction of demand like in passive houses, A+++ equipment, residents' behavior becomes a great money saving strategy. A 'cheap' vacuum cleaner with a capacity of 2 kW is therefore an expensive vacuum cleaner. 'Better' behavior can be supported by domotica (home automation or smart home involving the control and automation of lighting, heating, ventilation, air conditioning, security, appliances...) this is all systems like day light regulation, and presence detection (Van der Leeuw, 2006).

Reducing demand for electricity and gas has another great benefit because it also means that the required energy infrastructure is reduced. Of course if the district heating system will be applied more this again means more subsurface infrastructure.

Sustainable urban development is now defined by renewable electricity and heat, in the case of electricity even bi-directional meaning that the end users also supply electricity to the grid and have become electricity producers (IST, 2009). The natural gas can be replaced by locally produced gas from fermentation gas from black water and organic waste, or by heat.

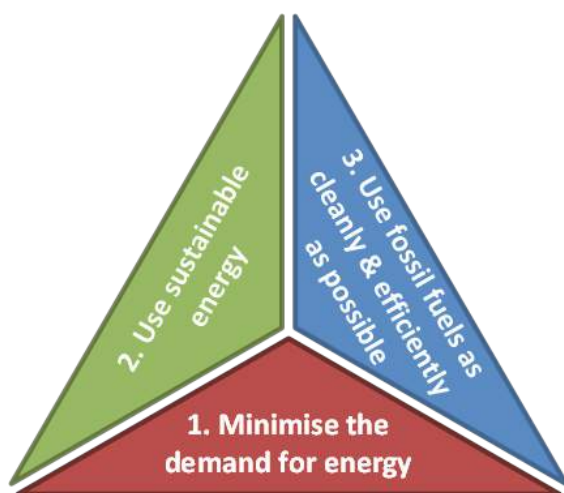

Figure 18
The Trias Energetica
Source: https://www.energy-watch.nl/images/articles/twente/trias_energetica_en.png

Current district heating in the Netherlands is heat produced with fossil fuels, but in some places with partially renewable sources like waste incinerators (AVI), waste heat from plants, heat from the deep soil (geothermal) or biomass combustion. Important for district heating is that there is a minimum of 2,000 households of sufficient heat demand and that heating for the house is disconnected from hot tap water, which need to be of significantly higher temperature to prevent legionella. It proved to be more durable to disconnect the higher temperature from the lower temperature house heating. Geothermal energy can also be used as a source for a power plant (Hooimeijer, Puts & Geerdink 2016).

Energy demand

To be able to define what the potential of the changing mobility on the highway is for providing renewable energy systems to the adjacent neighborhoods, the current energy demand of these area's is described. For this purpose, Brounen et al. (2009) is used, a study that analyzed observations on some 300,000 dwellings in the Netherlands, gathered between January 2008 and December 2009. These dwellings have been registered by the National Association of Realtors (NVM).

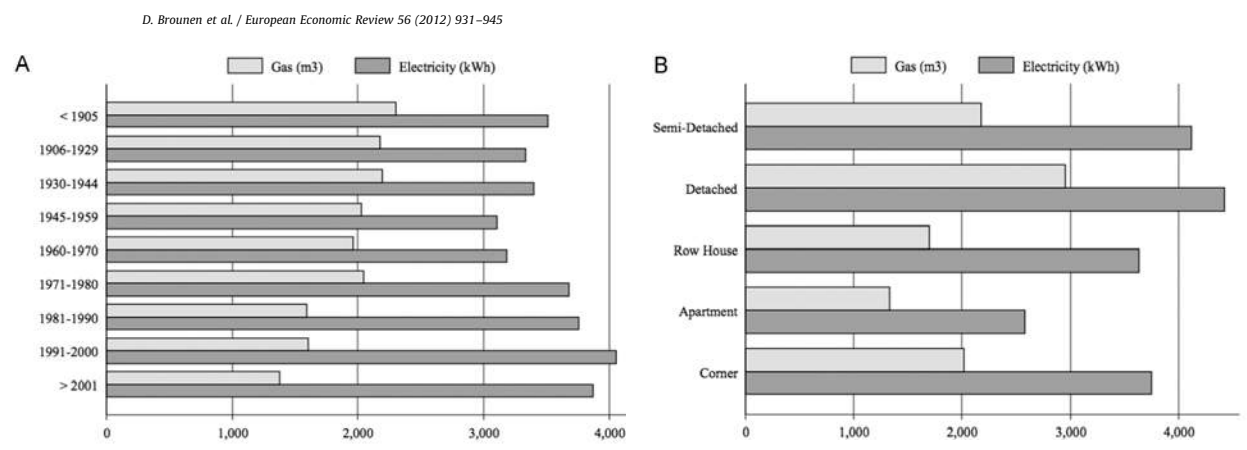

Figure 19
Annual energy consumption and dwelling structure. (A) Year and (B) dwelling type.
Source: Brounen D., Kok N., Quigley J.M. (2011) Residential Energy Use and Conservation: Economics and Demographics.

Table 9
Translating this to our samples

Year of building		Row house	Semi-detached	Detached	Apartment
1945-60	Electricity (kwh)	100.5	111.8	108	92
	Gas (m ³)	189	212.5	198.4	156.2
1970-80	Electricity (kwh)	106	111.4	119.5	102.3
	Gas (m ³)	160.9	178	200	160.9
1990-00	Electricity (kwh)	101	104	108.2	105
	Gas (m ³)	111	117.2	117.2	128.1

The table above gives some information about the energy consumption in our neighborhood typologies per house per year. The data have been extracted crossing the information on the previous diagrams.

The higher amount of electricity used have been registered on the semi-detached houses in the 1945-60 but in the 1970-80 and 1990-00 the detached houses are the typologies that are consuming more electricity, especially if the measurements are taken per apartment. The same study predicted a consistent demand per houses in the following years. The numbers are based on their simulation of energy consumption, from 2010 to 2030. Houses and apartment are not distinguished; consumptions are predicted for an 'average dwelling'.

As the table shows the simulation of the future energy consumption, divided by gas and electricity are progressively decreasing in the years range from 2010 to 2030 specially in the electricity line where the prevision set up a use of electricity in 2030 of 96.8 kWh.

'At present this data does not exist in the Netherlands, as became apparent during the interview with Olaf van Pruissen from TNO/ECN (Pruissen, 2012). 'Sustains Groenewoud Roderick.' Measurements are not made at these sub-stations to determine the energy demand in a neighborhood, but are only based on a combination of statistical models and the annual gathering of the total household consumption.'

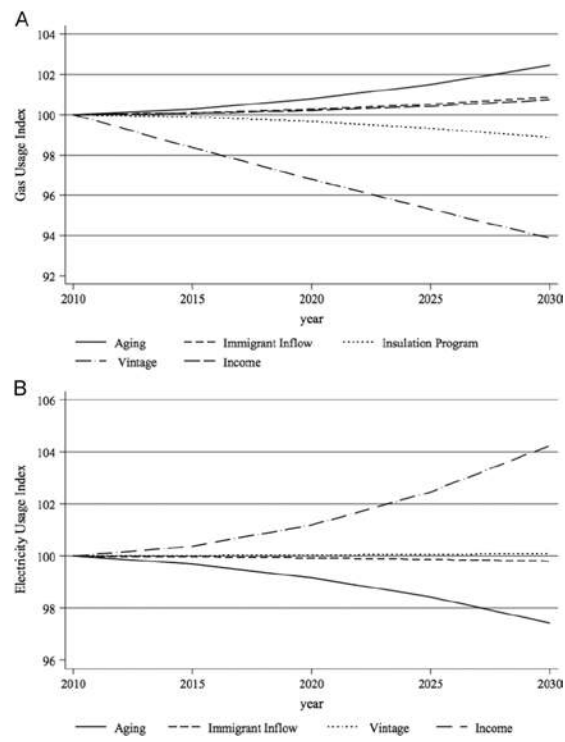

Fig. 6. Simulated future energy consumption. (A) Gas (m³) per dwelling and (B) electricity (kWh) per dwelling

Figure 20
Simulated future energy consumption. Source: Brounen D., Kok N., Quigley J.M. (2011) Residential Energy Use and Conservation: Economics and Demographics.

The energy supply on district scale

On the larger scale of a district there are the following energy supply combinations:

- Natural gas and electric (this is Dutch standard),
- District heating and electric,
- All electric in situations where there is no natural gas infrastructure and where heat pumps can be installed,
- District heating, natural gas and electric, is applied in Post War and '70 areas where for the heat residual sources are available (TNO & ECN, 2010)

The choice for a combination is founded by the density and the intensity of energy use. For the end user the guaranteed supply, initial construction costs, fixed costs, environment and CO2

impact, capacity and flexibility are important. Next to that also the claim of space is a factor to incorporate when moving to new systems. In the study 'The Small Energy Atlas' of H + N + S Landscape Architects (2008) the spatial impact of energy production has become evident. This atlas is also very visual about the CO2 emissions of different energy types. The spatial impact of solar energy is quite high, a lot of roofs are needed, and for wind there are no mills suitable for urban areas.

To achieve the energy transition within a new economy based on this (VPRO Tegenlicht, 2016) the source of the energy also needs to be sustainable. For heat these sources are biomass, geothermal and solar heat. For electricity these sources are sun, wind and biomass. Natural gas can be sustainable when using locally harvested biomass. Especially electrification on the base of renewable sources like wind, solar and biomass in combination with the use of heat pumps makes it possible to create a completely energy neutral city.

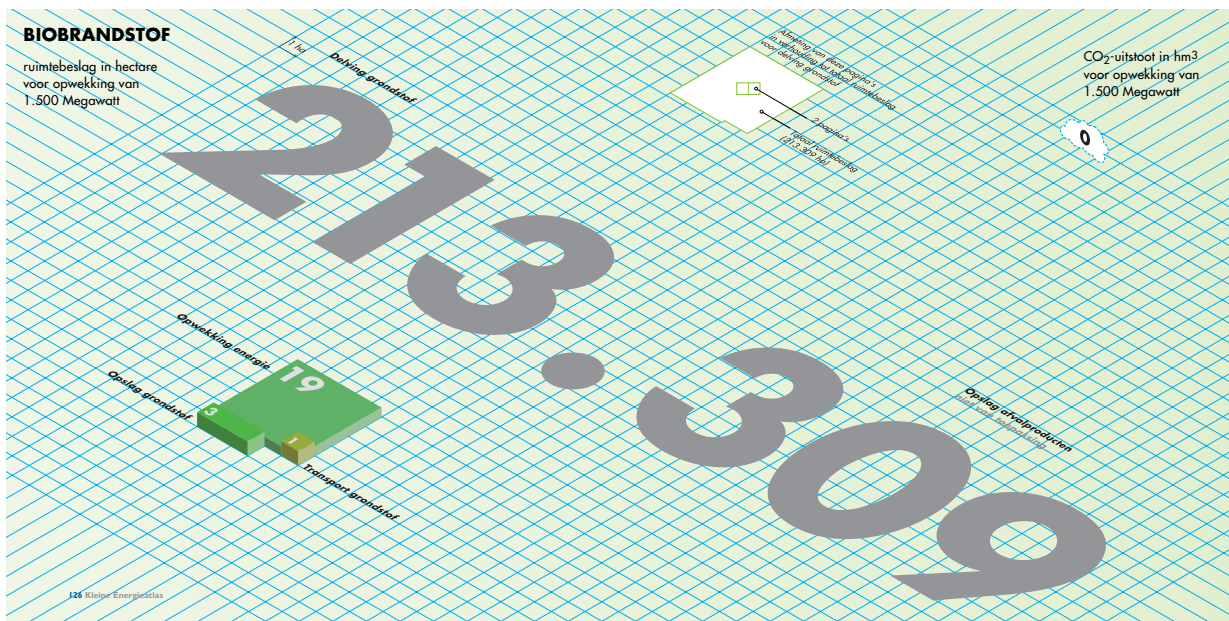

Figure 21
Biofuel claimed space
Source: H+N+S Landscape Architects, 2008

Heat

Most used source for heat in the Netherlands is natural gas. However, the resources of gas are finite and the mining of the gas at this point are causing earthquakes. Moving to bio gas is an option but for cooking much more is transformed into electric.

District heating

District heating is only attractive in areas where houses need to be renovated. It takes a large scale implementation of subsurface infrastructure which is costly and competing with other functions in the subsurface like water storage or underground space.

Active Solar Heating

Active solar heating systems use solar energy to heat a fluid - either liquid or air - and then transfer the solar heat directly to the interior space or to a storage system for later use. If the solar system cannot provide adequate space heating, an auxiliary or back-up system provides the additional heat. Liquid systems are more often used when storage is included, and are well suited for radiant heating systems, boilers with hot water radiators, and even absorption heat pumps and coolers. Both liquid and air systems can supplement forced air systems.

Storing heat in soil or water

The heat capacity of a material, along with its mass and its temperature, tell how much thermal energy can be stored in it. For example, for a given square tub full of water one-meter-deep and one meter on the sides, we have one cubic meter of water which weights 1000 kg (water density is 1000 kg/m³). If the temperature of the water is 20 °C (293 °K), then this cubic meter of water has 1.2 billion Joules of energy (=1000 [mass] x 4184 [heat capacity] x 293 [temperature in °K]). Let's consider two cubic meters of material (one is water, the other air). Air has a heat capacity of about 700 Joules/kg/°K and a density of just 1.2 kg/m³, so its initial energy would be 700 x 1 x 1.2 x 293 = 246,120 Joules, which is a tiny fraction of the thermal energy stored in the water. According to the Stefan-Boltzmann law, the two cubes will radiate the same amount of energy from their surfaces, if they are at the same temperature. If the energy lost in an interval of time is the same, the temperature of the cube of air will decrease much more than the water. In the same interval of time, water will radiate more energy than the air, yet the air will have cooled even more, so it will radiate less energy. In other words, the temperature of the water cube is much more stable than the air — the water changes much more slowly. The figure above shows the results of a computer model that tracks the temperature of these two cubes.

In summary, the higher the heat capacity, the greater the thermal inertia (temperature is less easily changed). This concept is an important one since Earth is composed of materials with very different heat capacities (water, air, and rock) which respond to heating and cooling quite differently.⁴

⁴ <https://www.e-education.psu.edu/earth103/node/1005>

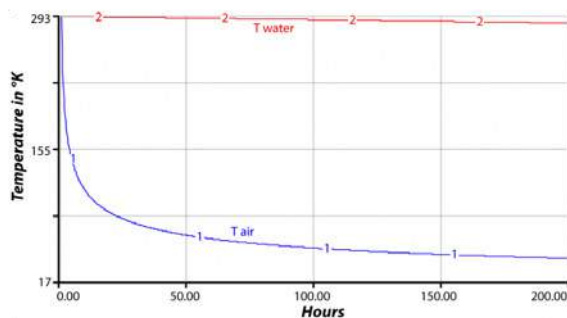

Figure 22
Storing heat in soil or water
Source: <https://www.e-education.psu.edu/earth103/node/1005>

The heat capacities for some common materials are given in the table below.

Figure 23
Heat Capacity of Earth Materials
Source: <https://www.e-education.psu.edu/earth103/node/1005>

Substance	Heat Capacity (Jkg ⁻¹ K ⁻¹)
Water	4184
Ice	2008
Average Rock	2000
Wet Sand (20% water)	1500
Snow	878
Dry Sand	840
Vegetated Land	830
Air	700

Geothermal and solar heat ⁵

Geothermal energy uses the stable temperature of the earth that is stored feet under the surface. Regardless of the outside temperature, the temperature of the earth a few feet underground remains constant. The geothermal system relies on a series of pipes that are buried in the ground, and that store and transfer the temperature.

Over time, a substantial energy saving can be gained by using geothermal energy to heat and cool a building. This is because energy is not used to produce heat, but it is used to move heat through a system. Geothermal heating (or cooling) is also financially beneficial since it can reduce the cost of heating by 2/3rds compared to propane use.

Geothermal energy is an extended beneficiary of the passive solar element of the Earth's ability to store and absorb the sun's heat in its mass. Thus, theoretically it can be debated as an extension of passive solar heating and cooling.

The geothermal loop system is often installed vertically or horizontally, depending on the available area of land. A horizontal loop would require 1 acre of land, whereas a vertical loop needs less area but more depth (3-5 feet underground).

⁵ <https://greenpassivesolar.com/sustainable-renewable-energy/geothermal-energy/>

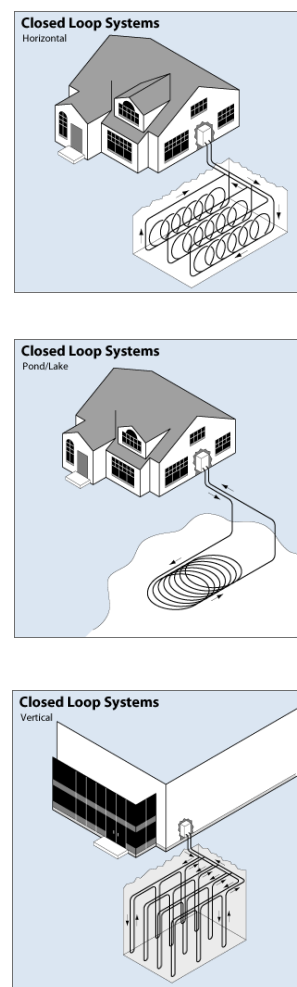

Figure 24
Geothermal loop systems
Source: DOE-NREL

Electrical heating

Electricity

All electric infrastructure is probably only attractive when a) renewable electricity can be locally generated and b) electricity consumption has been reduced by energy efficient equipment (including heat pumps) and c) 'smart grids' that are evolved grid systems that manage electricity demand in a sustainable, reliable and economic manner and that is built on advanced infrastructure to facilitate the integration of all involved⁶, to prevent further subsurface infrastructure. Decentralized systems to produce electricity are windmills, PV panels and new innovative systems to produce electricity on roads. But what are the potentials of these resources?

Windmills

In a wind farm the turbines occupy less than 1% of the land area. Activities like farming and tourism can take place around them and animals like cows and sheep are not disturbed. More and more householders are interested in generating their own electricity by using small scale wind turbines, either on their roofs or in their back gardens.

The ability to generate electricity is measured in watts, or more commonly in kilowatt (kW = 1,000 watts), megawatt (MW = 1 million watts), and gigawatt (GW = 1 billion watts) to describe the capacity of wind turbines or other power plants. Electricity production and consumption are most commonly measured in kilowatt hours (kWh) which means one kilowatt of electricity produced or consumed for one hour.

The output of a wind turbine depends on its size and on the wind's speed. An average onshore wind turbine with a capacity of 2.5–3 MW can produce more than 6 million kWh in a year – enough to supply 1,500 average EU households with electricity.

An average offshore wind turbine of 3.6 MW can power more than 3,312 average EU households. Wind turbines can generate electricity for about 20–25 years. Over their lifetime they will be running continuously for as much as 120,000 hours. This compares with the design lifetime of a car engine, which is 4,000 to 6,000 hours.⁷

⁶ <http://new.abb.com/smartgrids/what-is-a-smart-grid>

⁷ <http://www.ewea.org/wind-energy-basics/faq/>

House Solar Energy

An average 4 kW solar panel system will generate around 3,400kWh of electricity a year, which is enough electricity to individually power:

- 4,857 hours of the washing machine
- 97,143 hours of the fridge
- 1,880 hours of boiling the kettle
- 1,417 hours of the oven⁸

The size of the system is the most important factor of all. The typical domestic installation is a 3.5 kW system, which is normally around 12 panels. A smaller 1kW domestic system is likely to be only 2 panels. The direction that your roof faces and the angle of the roof comes next. For optimum performance, your panels will need to be on a 35-degree angle, facing south.

The time of year will also have an impact. During longer daylight hours in the summer you will be able to produce proportionally more power. That said, it's important to remember solar panels work from light not heat so will still produce energy all year round.

Road Piezoelectricity

Vibration energy is a sustainable alternative and a local energy source. A pilot research project was held on the N34 provincial motorway near Hardenberg in the autumn of 2011, and showed vibration energy is a sustainable alternative for batteries of roadside sensors for example. The project consisted in implementing on the road surface a piezoelectric material that converts vibrations from passing vehicles into energy. The technology is based on a principle called the piezoelectric effect, in which certain materials have the ability to build up an electrical charge from having pressure and strain applied to them. The energy exchanged with the road by friction isn't important but if just a fraction of it can be captured and turned it into usable electricity, the savings could be huge when factoring in tens of thousands of vehicles driving over a road on a daily basis. It was estimated that the energy generated from a 10-mile stretch of four-lane roadway could power a city of 100,000 inhabitants.⁹

⁸ <http://www.theecoexperts.com/solar-panel-output/>

⁹ <https://www.utwente.nl/en/news/!/2012/2/235602/generating-electricity-from-vibrations-in-road-surface-works>



Figure 25

Piezo device in road.

Source: <http://www.drroyspencer.com/wp-content/uploads/piezo-device-in-road-surface.jpg>



Figure 26

SolaRoad, Amsterdam

Source: http://img.theepochtimes.com/n3/eet-content/uploads/2015/05/11/DSC8910_kinderenvanboven2.jpg

Road Solar

The 70 meters SolaRoad which connects Krommenie and Wormerveer on the outskirts of Amsterdam has opened in November 2014. The test track along a bike path produces 70 kWh/m²/year and is more efficient than expected. It has indeed produced more than 3,000 kilowatt-hours of energy which is enough to power a single small household for one year.

The road is 230 foot wide and embedded with solar cells that are protected by two layers of safety glass. It is built for bike traffic, a use that reflects the road's environmentally-friendliness and the cycling-heavy culture of the Netherlands. However, according to the project's developers, the road could withstand heavier traffic if needed.¹⁰

37

Conclusion

Energy is one of the big demands in the next city generation. Both possibilities to produce energy from the highway and the neighborhood are valuable. Since we are still applying the possibility to use cars as main transport system, they will become the energy transmittance system as well.

Energy produced on the road will serve to charge cars but also public light. On the other way energy produced within the house can be used in the house and also for the public net.

Energy accumulated by cars in recharging batteries from the highway can be released in the house through an inverse system.

We can divide the energy production in two main categories, private and public investments. If road and infrastructure can be renewed by public investments, private houses need private investments. Through further studies we can assume that energy produced by the highways can be the starting point to renew our neighborhood typologies.

¹⁰ <https://thinkprogress.org/the-worlds-first-solar-road-is-producing-more-energy-than-expected-c51540906eb>

3.3.4. New building program

The quantification of samples is done on the basis of the Space Mate (Haupt and Berghauser Pont, 2010). Each sample has a surface of 90,000 m² and the typical numbers of land use and building surface are derived from the Space Mate. On the base of the issues described in §? a new future can be formulated in the design.

New Program

The descriptions of the three typology samples also put forth their societal spatial issues. The VI-NEX locations are quite new and no new dynamic is to be expected soon, although the new mobility could lead to introduction of hubs or charging centers in these areas. In the analyses of the *Woonerf* sample some future functional and spatial changes are defined:

- Adding of 3.000 m² shops,
- More infrastructure,
- More surface water.

The Post-War areas are under higher dynamics

as shown in Table 10 due to the fact that current housing needs are not met and also the public spaces need to be modernized. Especially here the perspective of new program is valid, in changing housing typology and in adding new program. The fact that the infrastructure system is quite intensive it is also easier to expand the urban program over the buffer and highway. Per prototype highway this extension has different options:

- **Floor:**
the infrastructure is more a barrier and larger investments are needed to build,
- **Dike:**
this profile is easier to cover with program by connecting bridges,
- **Stilts:**
the program can be easily connected under the highway, build up in buffer,
- **Ditch + dike:**
this profile is easier to cover with program by connecting bridges,
- **Ditch:**
this profile is easier to cover with program by connecting bridges.

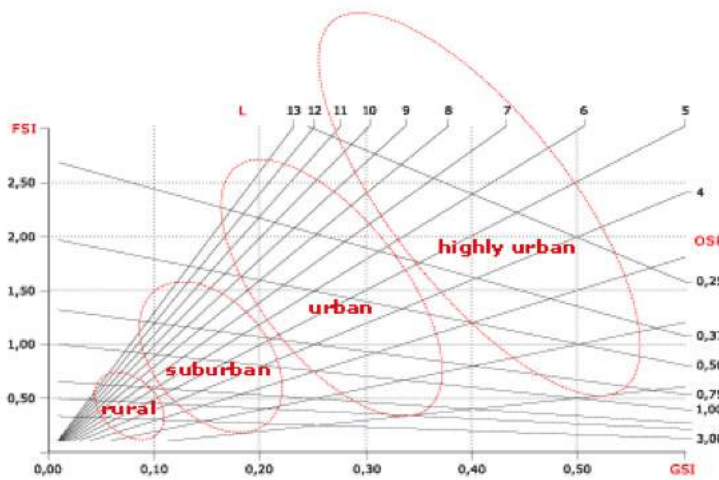

Within the matrix are groups of rural, suburban, urban and highly urban representative types of existing urban typologies.

FSI=Floor Space Index = m² floor surface/m² ground surface;
 GSI=Ground Space Index = m²; build surface. /m² ground surface;
 OSR=Open Space Ratio = m² unbuilt surface/m² ground surface;
 L=building layers

The relationship between FSI and GSI leads to a certain type of urban weaving principle: FSI 0 to 0.75 and GSI is 0-0.1 rural area, FSI from 0.25 to 1.50 and 0.8 to 0.22 GSI, is low urban, FSI 0.30 to 2.5 and from 0.18 to 0.38 GSI is urban and FSI greater than 0.5, in combination with the GSI between 0.25 and 0.55 is center high density.

Figure 27
Space Mate (Haupt and Berghauser Pont, 2010)

Table 10
Quantification of the three samples for the current and future situation
Source: TNO & ECN, 2010 and altered for this research

	Post-War		Woonerf		VINEX	
	Current	Future	Current	Future	Current	Future
Total surface [m2]	90.000	90.000	90.000	90.000	90.000	90.000
Build up surface [m2]	27.000	30.000	19.200	20.700	20.200	20.200
Unbuilt surface [m2]	63.000	60.000	70.800	69.300	69.800	69.800
Housing slab 1950s renovation [m2]	16.500	16.500				
Revenue houses 1950s demolished [m2]	16.500	0				
Revenue houses 1950s renovation [m2]	33.000	33.000				
Ground bound family houses 1970 renovation [m2]			40.000	40.000		
Ground bound family houses new [m2]	0	13.500				
Ground bound family houses 1990 [m2]					7.500	7.500
Flats 1990 maintenance [m2]					60.600	60.600
Towers new [m2]						
Offices 1960 low rise renovation [m2]	1.000	1.000				
Offices 1960 demolished [m2]	1.000	0				
Offices new [m2]		1.000				
Schools 1950s renovation [m2]	750	750				
Schools 1970s renovation [m2]			750	750		
Schools new [m2]					750	750
Supermarket 1950s [m2]	1500	1500				
Shops 1980s [m2]						
Shops new [m2]			0	3.000	15.000	15.000
Green surface [m2]	39.400	34.000	44.520	41.580	14.800	14.800
Infrastructure surface [m2]	20.000	20.000	19.080	20.790	28.200	28.200
Water surface [m2]	3.600	9.000	7.200	9.000	5.400	5.400

The infrastructural extensions are the base for the new program coming from the field. But also a new approach in adding program from the line in the buffer is an option: N4 model. One of the effects of the new mobility is that more exits and entrances can be introduced. In the design proposals of this study this is called the N4 model. The N4 is a highway in Belgium that actually has housing addresses along it. Artgineering (2007) studied this road extensively putting into perspective the potential of the Nationale 4 in Belgium as source of inspiration for a new conception of the regional infrastructural network.

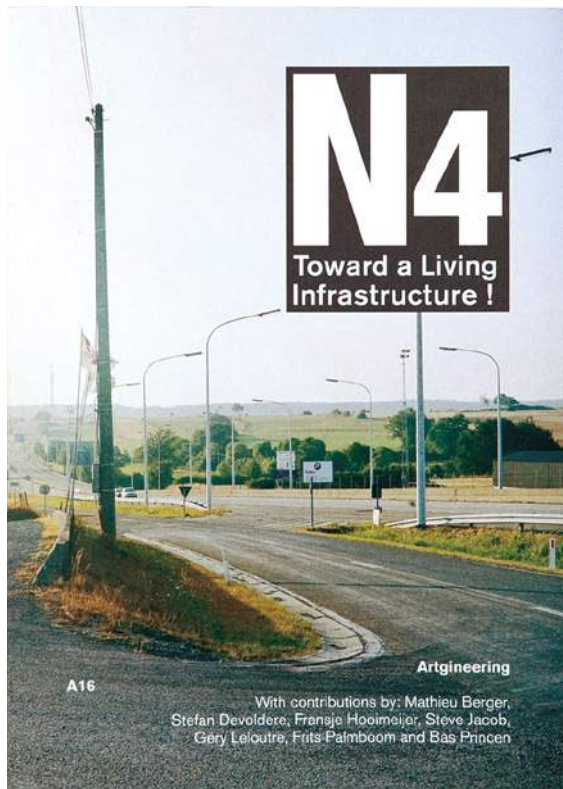

Figure 28
N4: Toward a Living Infrastructure
Source: Artgineering, 2007



41



Figure 29
Pictures from the N4 in Belgium.
Source: Artgineering, 2007

Starting from the study done by West 8, *Research into a healthy relation between city and highway* (2013), the defined prototypes of highways are assessed and five are selected to use in further study. These are related to three urban typologies, the 50s, 70s and 90s, that have different positions to the highway, different relation to car mobility and different spatial and societal issues at hand. In these 15 combinations the future use of the highway is projected in two phases, first phase is cleaning up of the polluted buffer zone and in the second the potential of the urban typology is utilized to also address the issues of waste water treatment, energy and new program to enhance the resilience of the area. This has resulted in an overview of spatial potentials for each combination in order to become more resilient.

Considering these aspects of the larger aim for future resilient infrastructures that is considered as 'durability plus', a stable relation between the human and natural systems, the 15 combinations are now set against the investigation into the four topics:

42

- Gentle remediation option (phase 1)
- Waste water treatment (phase 1 and 2)
- Energy production (phase 1)
- New building program (phase 2)

4.1 Phase 0: The current situation

1950's: Post War

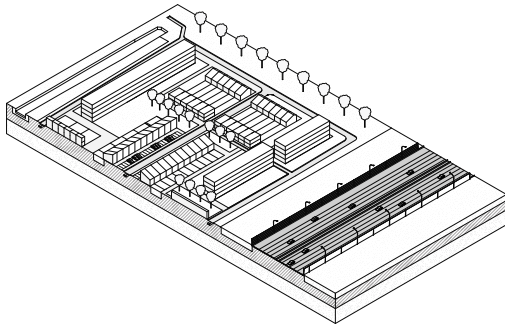

Floor

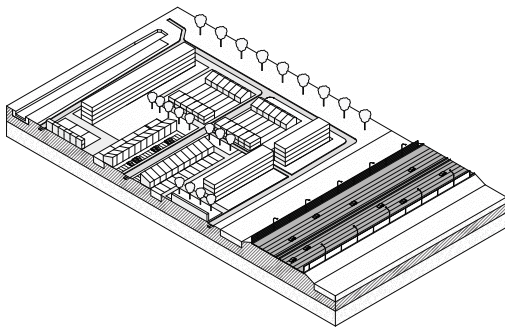

Dike

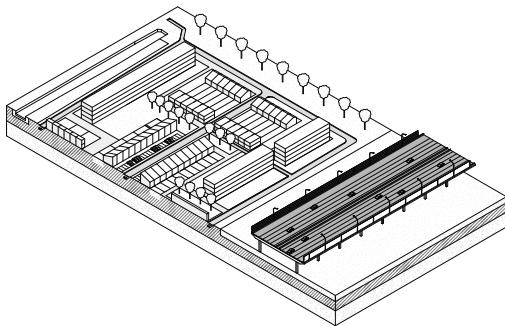

Stilts

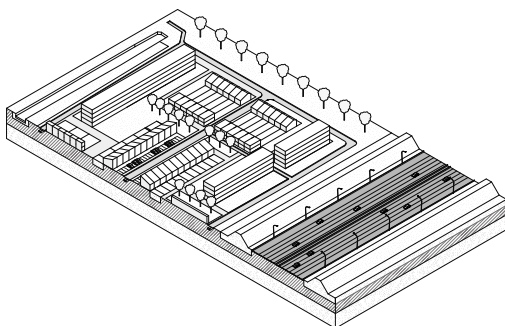

Ditch + Dike

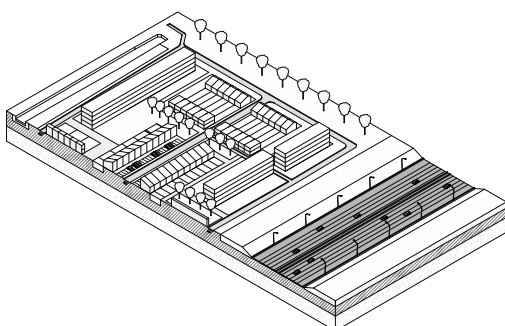

Ditch

1970's: Woonerf

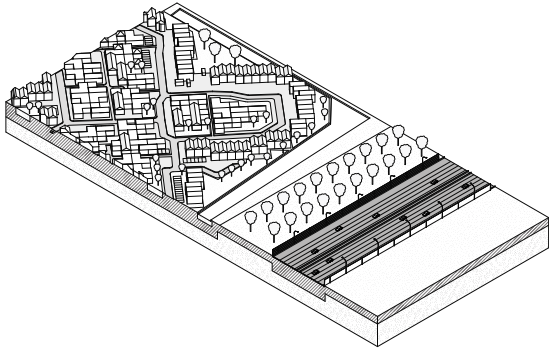

Floor

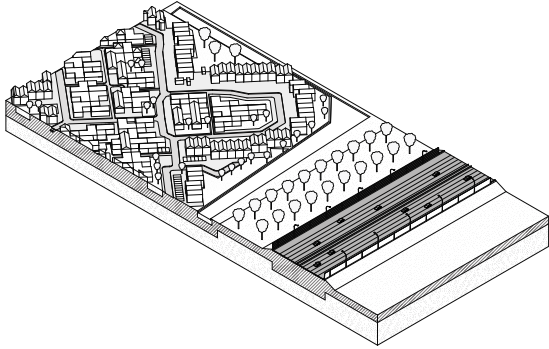

Dike

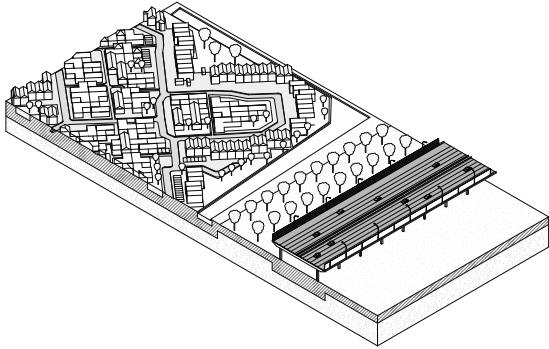

Stilts

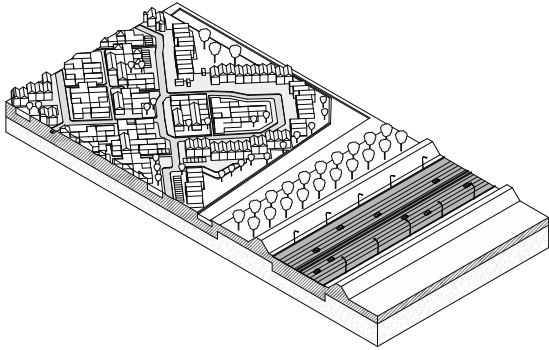

Ditch + Dike

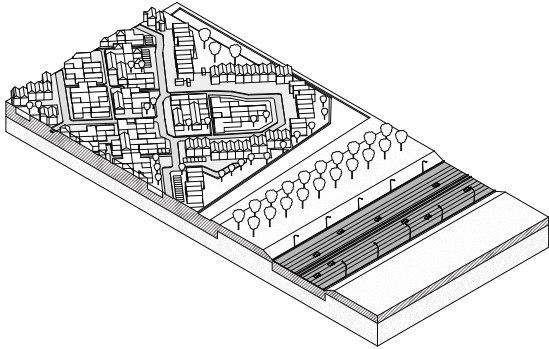

Ditch

1990's: VINEX

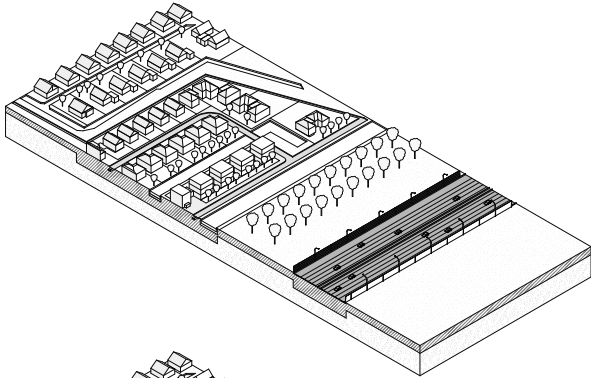

Floor

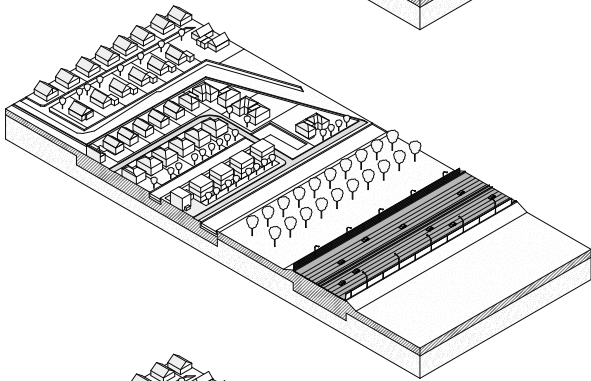

Dike

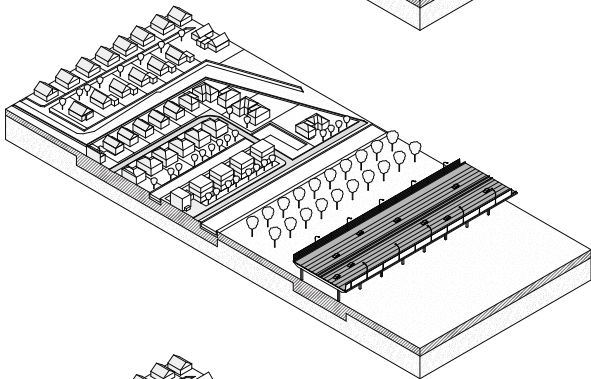

Stilts

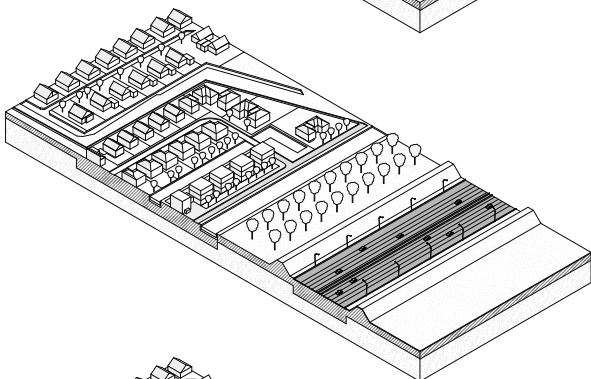

Ditch + Dike

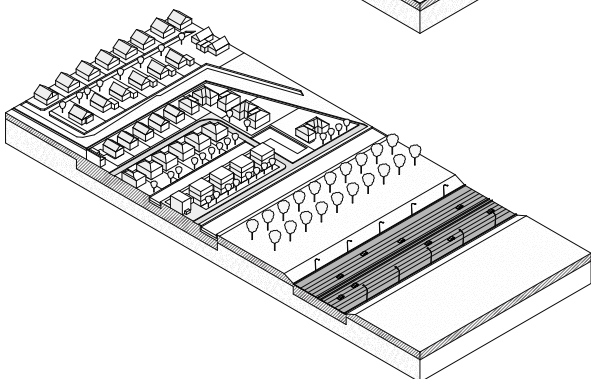

Ditch

Phase 0 is the current situation with potentials described in table 11.

Phase 1 is the intermediate phase of 10 years
The buffer in all combinations of prototypes and typologies can be remediated with plants
The buffer in all combinations of prototypes and typologies can be used to place PV
The buffer in the combination of prototype x and urban typology x can be used for natural waste water treatment.

Phase 2 is the final, urbanized use of the highway, buffer and connected to urban area. They are described by street hierarchy, housing blocks, public space structure and design (ecology). The main aim of the research by design is to assessing the performance in relation to:

- **Design codes**
investigating the spatial potentials of typologies in relation to the prototypes,
- **Environmental factors**
studying the influence of changing environmental (ecological) conditions around the infrastructures,
- **New combined uses**
thinking it is not only a line for cars but how changes open up for new urban multifunctional development.

Table 11
Potential diagram of the typology

	Buffer space	OSR inside the Neighborhood [#]	Amount waste water produced [*]	Amount electricity use ^{**} (Kwh/y)	Amount gas ^{**} (m3/y)	Parking places (m2) ^{##}	Functions
1950's	30 x 200 m 6000 m ²	63.000 m ²	G:47L/per/day B:37L/per/day	44.302,5	43.407,5	4.556,6 m ²	Housing+super-market, schools, offices
1970's	50 x 200 m 10000 m ²	70.800 m ²	G:47L/per/day B:37L/per/day	25.670,7	25.200,5	1773,8 m ²	Housing+schools
1990's	70 x 200 m 14000 m ²	48.400 m ²	G:47L/per/day B:37L/per/day	20.497,95	20.083,85	1641,25m ²	Housing+schools

data coming from table 7

* ref table 6 G: Grey B: Black

**ref table 9

in 2017 gas demand per dwelling has been electricity 99 Kwh/y and gas 97m3/y assuming:

In 1950s the apartments were 50m² (40%) but the family houses 70m² (60%)

In 1970s the apartments were 66m² (60%) but the family houses 90m² (40%)

In 1990s the apartments are 80m² (50%) and family houses 125m² (50%)

parking ration 1,5 place per apartment.*

* <https://www.cbs.nl/nl-nl/achtergrond/2013/04/twee-derde-van-alle-woningen-eegezinswoning>;
<http://www.bestaandewoningbouw.nl/de-maten-van-het-wonen-een-lange-traditie/>;
<http://www.bestaandewoningbouw.nl/een-begane-grond-van-rond-de-50m-2/>

4.2 Phase 1: The intermediate phase

- Gentle remediation
- Highway as energy resource
- Space for waste water treatment.

The first phase is seen as an intermediate phase which will last at least 10 years, this time can be subject of variation depending the buffer in all combinations of prototypes and typologies and consequently the plants used. In the phase the focus is on cleaning of the buffer area. Each of the buffer prototypes are studied to accommodate a gentle remediation process, as well as space for waste water treatment as various possibility for energy productions.

Since the time needed to remediation the buffer, the project introduces a second layer in which this space is also utilized to produce energy, in all combination possible, from bump road to wind mill to solar panels. Part of the buffer area can also accommodate natural waste water treatment. Uncleaned soil can be accumulated in order to facilitate the remediation.

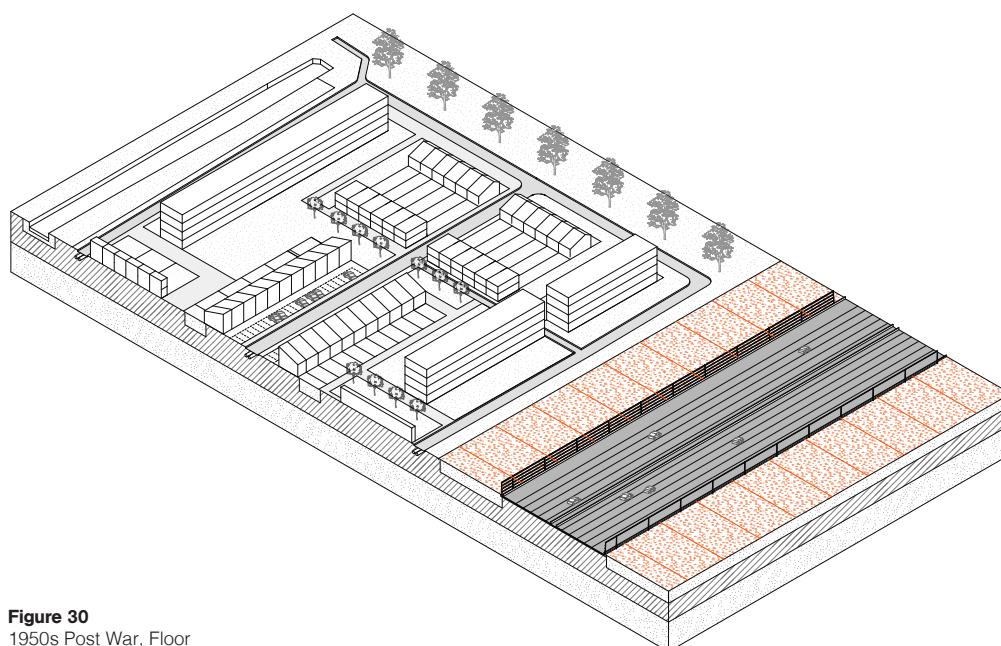

Figure 30
1950s Post War, Floor

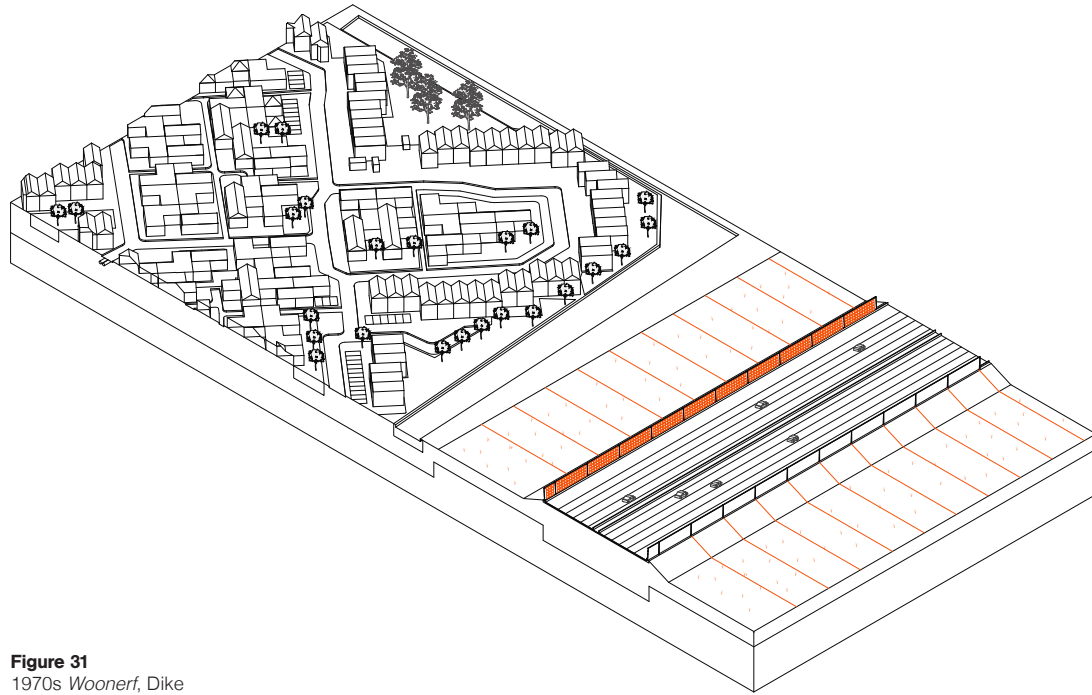

Figure 31
1970s Woonerf, Dike

Table 12
Space, energy and waste water treatment

	Buffer space	OSR inside the Neighborhood#	Amount waste water produced *	Electricity demand ** (Kwh/y)	Gas demand ** (m3/y)	Parking places (m2)##	Functions
50's	30 x 200 m 6000 m ²	63.000 m ²	G: 47 L/pers./day B: 37 L/pers./day	48.706	46.718	5.058,75m ²	Housing + small shops + schools
70's	50 x 200 m 10000 m ²	71.370 m ²	G: 47 L/pers./day B: 37 L/pers./day	27.440	26.320	1.913 m ²	Housing + schools + shops
90's	70 x 200 m 14000 m ²	48.400 m ²	G: 47 L/pers./day B: 37 L/pers./day	20.290,9	19.462,7	1.641,25 m ²	Housing + schools + shops

data coming from table 7

* we presume we have the same amount of waste water G: Grey B: Black

** vision following the table 9: in 2030 electricity demand per dwelling will be 98 Kwh/y and gas 94 m3/y assuming: we are not changing the apartment typologies

In 1950s the apartments were 50m² (40%) but the family houses 70m² (60%)

In 1970s the apartments were 66m² (60%) but the family houses 90m² (40%)

In 1990s the apartments are 80m² (50%) and family houses 125m² (50%)

parking ration 1,5 place per apartment.*

* <https://www.cbs.nl/nl-nl/achtergrond/2013/04/twee-derde-van-alle-woningen-eengezinswoning>;

<http://www.bestaandewoningbouw.nl/de-maten-van-het-wonen-een-lange-traditie/>;

<http://www.bestaandewoningbouw.nl/een-begane-grond-van-rond-de-50m-2/>

4.3 Phase 2: Highway, buffer, urban area

In the second phase the combinations are further developed. For the Post War urban typology main focus is put in adding new program and secondary energy and waste water treatment interventions are proposed. The *Woonerf* urban typology has the focus on energy and the VINEX on waste water treatment with the other topics coming in as secondary. The interventions on the building programme are listed below. The following pages are the descriptions of the combinations. The different topics mentioned are all described in the report.

<u>Urban typology:</u>	Post War '50s, car oriented 30 meter	Woonerf '70s, slow traffic oriented 50 meter	VINEX '90s, highway linked 70 meter
------------------------	--	--	---

West 8 prototypes
Characterizing aspects:

- Visual impact
- Connectivity
- Spatial quality

Build up program

Energy

Waste water treatment

Urban renewal interventions

Buildings in field:

16.500 m2 flats > 13.500 m2 ground bound family houses
1.000 m2 office space is demolished and built new.

Buildings in buffer:

New program

Buildings over the highway

New program

Housing

Buildings in field:

3.000 m2 additional commercial

Buildings in buffer:

New program

Buildings in buffer:

New program

1. Floor

Post War 50s: car oriented

- Potential to expand the highway to program in the existing buffer zone (N4 model) that is also connected to the urban area.
- Replacement of buildings in urban area.
- Cars are used as battery in the urban area.
- Infiltration crates

Woonerf 70s: slow traffic oriented

- Potential to expand the highway to program in the existing buffer zone (N4 model) that is also used as (underground) inter-modality for people in the urban area. Cars are charged here by energy production by the highway. The area will be more green for water management.
- Infiltration crates
- Smart Piping

VINEX 90s: highway linked

- Buffer zone is used for waste water treatment (grey and black). Highway is expanded with program that also is connected to the urban area. Cars are used as battery for the housing.
- SoSeal

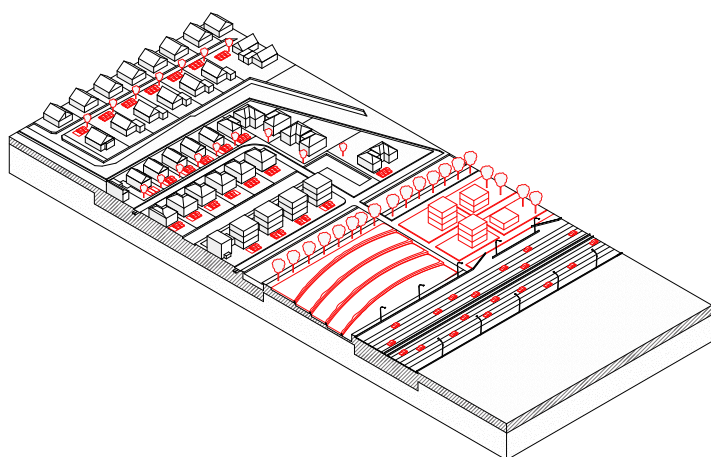
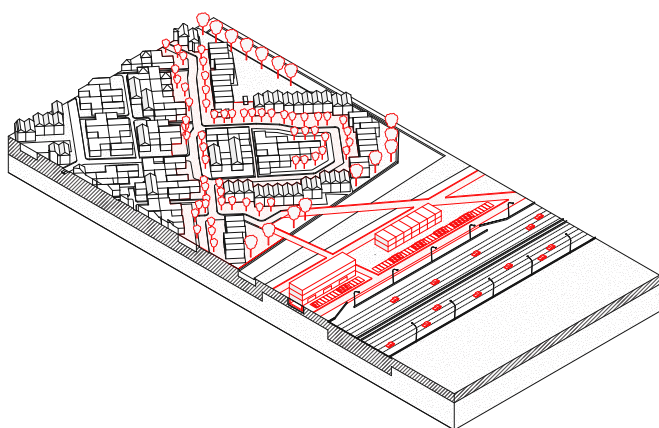
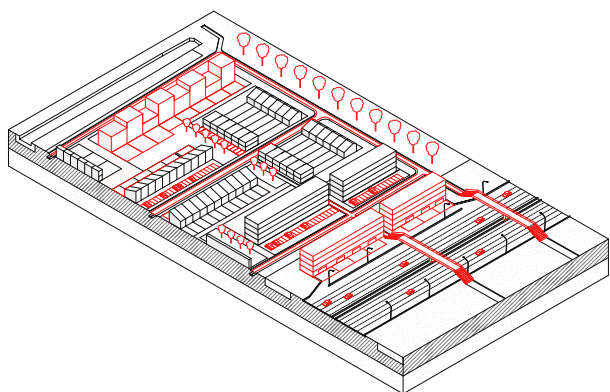

2. Dike

Post War 50s: car oriented

- Potential to expand the highway to program in the existing buffer zone (N4 model) that is also used as inter-modality for people in the urban area. Cars are taken out of the area and charged in the buffer zone. Urban area is more green for water.
 - Underground buildings
 - Smart piping
-

Woonerf 70s: slow traffic oriented

- The buffer zone is programmed as park. Cars are parked at the highway and charged by energy produced by the highway. The area will be more green for water management.
 - Smart piping
 - Infiltration crates
-

VINEX 90s: highway linked

- Buffer zone is used for biomass plant fed by grey waste. Highway is expanded with program that also is connected to the urban area. Cars are recharged in the buildings in the buffer zone, making room for private black waste water treatment.
- Source separation
- Helophyte filters
- Smart piping
- Flexible pipes
- SoSeal

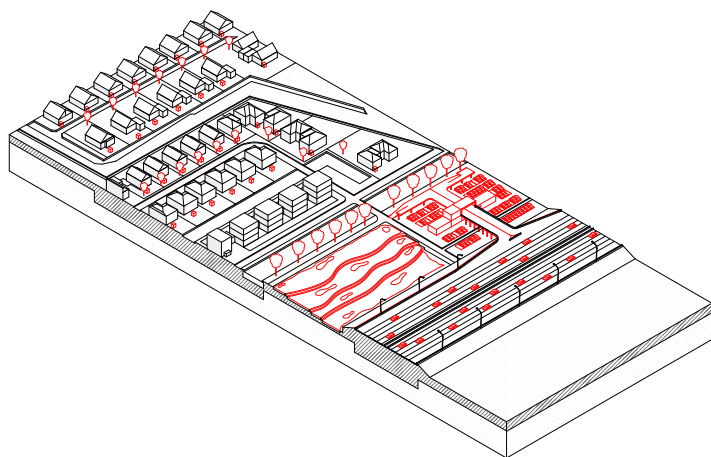
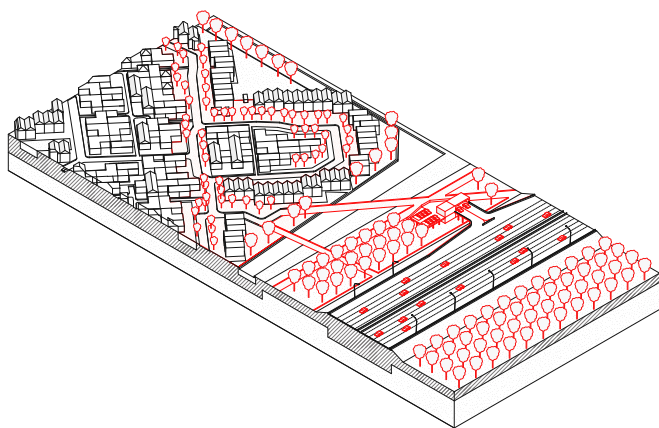
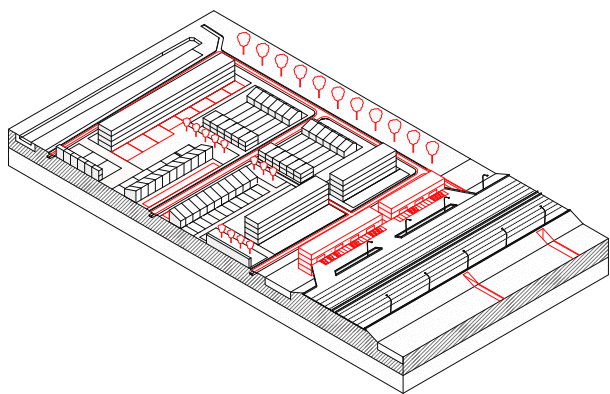

3. Stilts

Post War 50s: car oriented

- Potential to repeat the stamp pattern over the highway, making underpasses, and buffer zone for new build up program. Cars will be charged under the highway, making the urban area more green for water.
 - Underground buildings
 - Smart piping
-

Woonerf 70s: slow traffic oriented

- The buffer zone is programmed as park. Cars will be charged under the highway by energy generated on the road, making the urban area more green for water.
 - Smart piping
 - Infiltration crates
-

VINEX 90s: highway linked

- The whole buffer zone is used for wastewater treatment and run off of the highway. Moreover, other commercial and leisure uses related to the recovery of nutrients can flourish in the area, such as tree nursery farm.
- Helophyte filters
- Flexible pipes
- Soseal

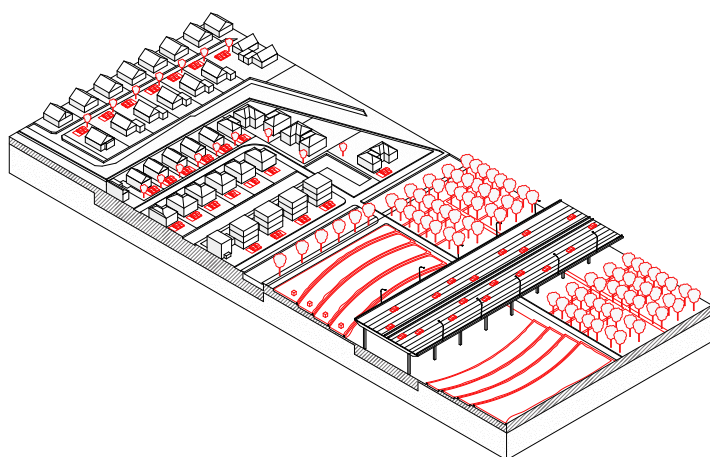
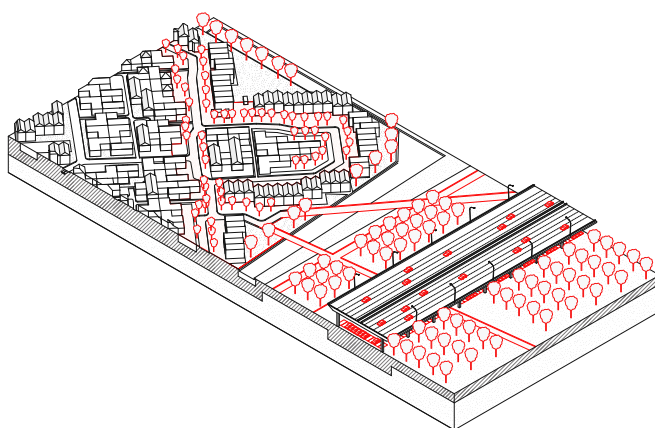
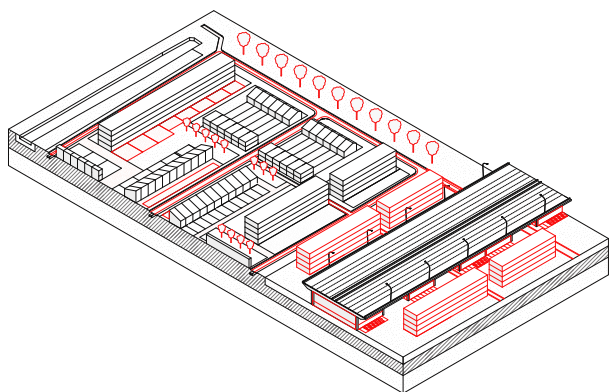

4. Ditch + Dike

Post War 50s: car oriented

- Potential to repeat the stamp pattern over the highway, making underpasses, and buffer zone for new build up program. Cars are taken out of the area and charged in the buffer zone. Urban area is more green for water.
 - Smart piping
-

Woonerf 70s: slow traffic oriented

- Cars will be charged on the highway by energy produced by the windmill park on the highway and in the buffer zone. Cars are used as battery for the houses.
 - Infiltration crates
-

VINEX 90s: highway linked

- The buffer zone is completely planted with trees, a biomass plant is built that is fed by the forest and the manure from the housing (separated sewer collection faces). Cars remain in the area as battery.
- Source separation

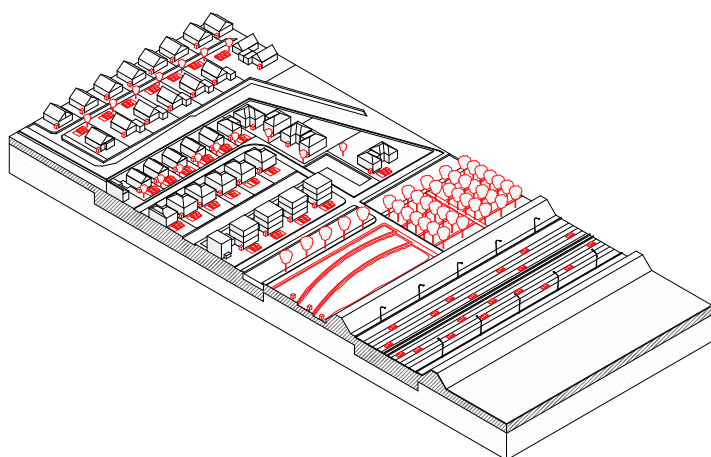
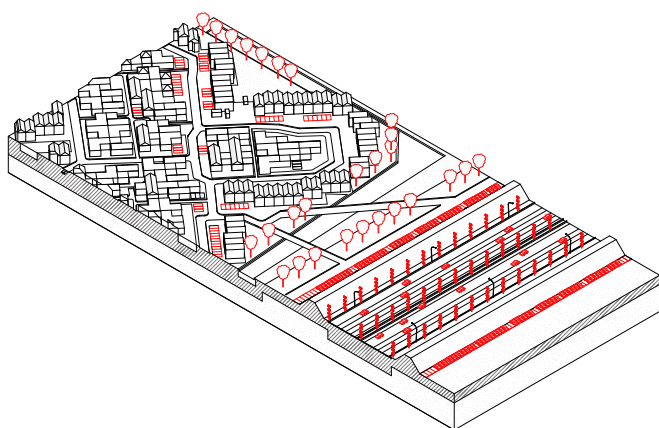
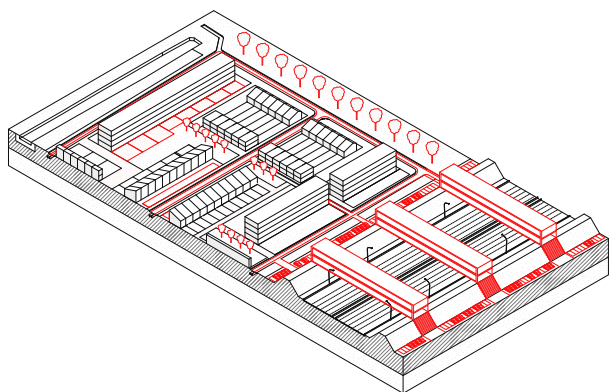

5. Ditch

Post War 50s: car oriented

- Potential to expand the highway to program in the existing buffer zone (N4 model) that is also used as inter-modality for people in the urban area. Cars will be in the area used as battery for the housing.
- Infiltration crates

Woonerf 70s: slow traffic oriented

- The buffer zone is completely planted with trees, a biomass plant is built that is fed by the forest and the manure from the housing (separated sewer collection faeces).
- Source separation
- Flexible pipes

VINEX 90s: highway linked

- The buffer zone is used for energy production in surface water (Den Bosch model). Soil is moved towards the highway; cars remain in the area as battery.
- Source separation

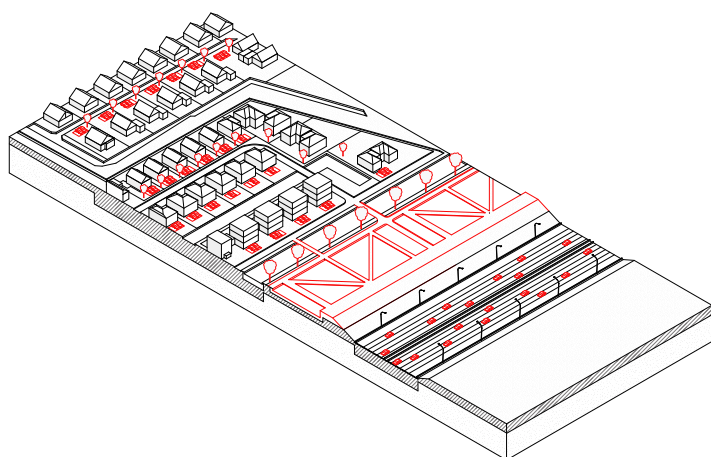
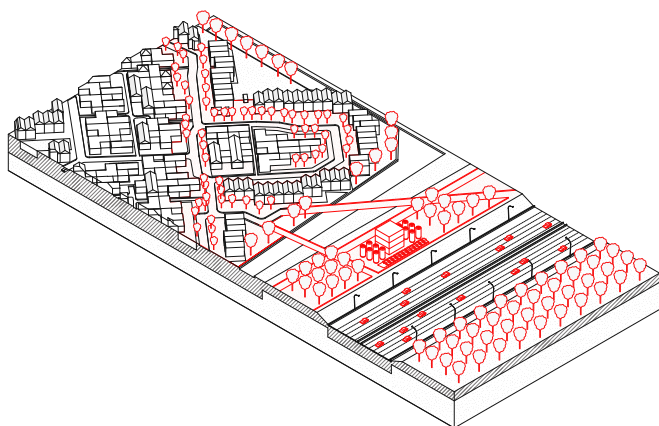
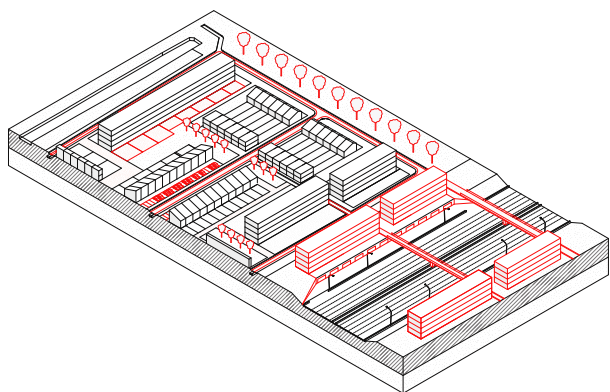

The main question of this explorative research is What part can the highway and the adjacent zone play in making cities more resilient so that they can achieve a sustainable and climate-proof future? By defining 15 combinations of highway prototypes and types of residential neighborhoods the resilience topics are tested and opened up a new approach towards infrastructure.

Spatial planning is about the distribution of space and particularly about the alignment of infrastructural planning and area development. Its ultimate goal is to improve the quality of life and that makes harmonization efforts increasingly important. New forms of mobility offer opportunities to make urban areas along highways more resilient by using those specific areas for the ecological and functional improvement of the city. This requires spatial interventions that approach the highway, the buffer zone and the specific urban area along the highway as a whole rather than as separate zones that just happen to be juxtaposed. Anticipating new forms of mobility, how can we design the correlation between these spaces and how can these spaces foster resilient urban systems?

To examine the correlation between highway and city, combinations of highway prototypes and urban types that represent the majority of urban territories along highways in the Netherlands are examined. Designs are made to activate and enhance urban resilience, quality and livability on a larger scale. How can the different combinations create spatial opportunities to enhance the resilience of a specific area? In this context, climate change, the energy transition and quality urbanization are of key importance. The need to mitigate and adapt changes in the hydrological

cycle, to reduce energy dependency and find more renewable energy sources is increasing, but at the same time there is less space available to achieve these things. The densification that is necessary to house the growing urban population involves problems in the fields of sustained urban quality and livability, (waste)water, energy, redevelopment and provisions for new forms of mobility. For each urban type, current qualities and opportunities to create a balanced relation between human and natural systems can be defined in relation to the present situation. In addition, we can address actual problems and shortcomings.

The adaptation of each urban type requires an incremental process that develops from the current situation (phase zero) and progresses during an intermediate stage of ten years (phase 1) toward a final horizon when the highway, the buffer zone and the residential area involved form a single urban fabric (phase 2). The redevelopment of the polluted buffer zone can be addressed by using natural technologies in combination with wastewater treatment. These are the earliest adaptations that take place in phase 0 and can continue during the whole of phase 1. The introduction of new buildings becomes relevant in phase 1, when the redevelopment through the introduction of plants nears its completion and energy production through various renewable sources yields sufficient results. During the second and last phase, new urban concepts emerge that, for all combinations of highway prototypes and urban types, couple matters of resilience with spatial matters, that is: the design of street hierarchy, residential blocks and the structure of public space and local ecology to improve livability.

The spatial operation perspective opens up an overwhelming potential of the future relation between the urban field that aligns the highway and the highway itself. This potential is not only created by future technological innovations on product scale but also by including environmental and vital infrastructure (water, waste and energy) a huge ecological and programming improvement of the three urban typologies can increase their resilience. This spatial operation perspective offers new trade-offs between field and line, between the human and nature system and includes a system approach that can identify potentials and issues in the field of different nature. It promotes an interdisciplinary approach in which the fragmentation caused by the highway lines are made useful and add to urban quality. This can be considered a further evolution of the RATIP approach.

Interdisciplinary working is crucial to tap into the potential of the changing dynamics on the highway line. It should not be a field in which mobility experts should operate alone, it is clearly another interdisciplinary challenge. This researched is explorative, especially in changing the perspective from the line, over the buffer into the field to a perspective from to field to the line. With this perspective strong coalitions can be made into making resilient urban infrastructure. This research offers a first exploration on making rules of thumb and creating general numbers for the redesign of the field, buffer and line. These numbers are quite rudimentary and make foremost clear that a lot of information is needed to be able to make the math.

references

- Artgineering (2007) N4 Toward a Living Infrastructure ! Brussel: A16. pp. 192-203
- Berghauer Pont MY & Haupt PA (2010) Spacematrix. Space, Density and Urban form. Rotterdam: NAI Publishers.
- Bodart M., Evrard A. (2011) PLEA 2011: Architecture & Sustainable Development. Louvain-la-Neuve: Presses universitaires de Louvain.
- Boeijenga J. & Mensink J. (eds) (2008) VINEX Atlas. Rotterdam: NAI Publishers.
- Boer J.D. de (2010) Beter kijken naar wijken Ruimtevolk. (More close look at neighbourhoods).
In :Ruimtevolk.
See : <https://ruimtevolk.nl/2010/10/20/beter-kijken-naar-wijken/>
- Boer de H., Boomen van den T., Hinterleitner J. (2017) Highway & City : The future of the urban rign road. Amsterdam : BNA Onderzoek.
- Brix, H. (1999) How 'green' are aquaculture, constructed wetlands and conventional wastewater treatment systems? Water Science and Technology.
- Brooks R.R., Robinson B.H., Howes A.W., Kirkman J.H., Gregg P.E.H. (1997) The potential of the high-biomass nickel hyperaccumulator *Berkheya coddii* for phytoremediation and phytomining. Journal of Geochemical Exploration. Publisher: Elsevier.
- Brounen Dirk, Kok Nils, Quigley John M. (2012) Residential energy use and conservation : Economics and demographics. In European Economic Review.
See: https://gspp.berkeley.edu/assets/uploads/research/pdf/BKQ_Res_Energy_Literacy_and_Conservation_021912.pdf
http://nilskok.typepad.com/BKQ/BKQ_Energy_2011.pdf
- Bruijn, K.M. de (2004) Resilience and flood risk management. Water Policy. Delft : Delft University Press.
- Calabrese L.M. (2004) Reweaving UMA : Urbanism Mobolity Architecture. Delft : TU Delft Press.
- Calace, N. Petronio B.M., Picciolo M., Pietroletti M. (2002) Heavy metal uptake by barley growing in polluted soils: Relationship with heavy metal speciation in soils. Rome: Marcel Dekker, Inc.
- Carmona M., Tiesdell S. (2007) Urban design reader. Architectural Press.
- CBS (2010) Voorraad woningen; mutaties en bouw, 1921-2011
See: <http://statline.cbs.nl/StatWeb/publication/?VW=T&DM=SLNL&PA=71527ned&D1=5-10&D2=a&HD=101129-1331&HDR=T&STB=G1>
- Cheung, J.T.O. (2014) Regional approach to infratructure provisio. Delft: Master Thesis University of Technology.

Chu J.Y., Chen J.N., Wang C., Fu P. (2004) Wasterwater reuse potential analysis: implications for China's water resources management. *Water Research*.

College van Rijksadviseurs (2010) *Prachtig compact*. NL. The Hague: Ministry I&M

Cundy A.B. et al. (2016) Brownfields to green fields : Realising wider benefits from practical contaminant phytomanagement strategies. *Journal of Environmental Management*.

See : <http://dx.doi.org/10.1016/j.jenvman.2016.03.028>

De Pauw N. & Salomoni C. (1991) *Aquaculture systems for wastewater treatment*. European Aquaculture Society Spec. Publ.

Dimitriou I. and Aronsson P. (2005) *Willows for energy and phytoremediation in Sweden*. Uppsala : Unassylva.

Dorst van M., Geerling L., De Graaf P., Vink Jacques J., Van de Wal H. (2011) *7Up. Zevenkamp als case study voor een duurzame herstructurering van jaren 70 en 80 wijken*. Delft : University of Technology.

See : <https://repository.tudelft.nl/islandora/object/uuid%3Afc3c86cb-12c6-4c75-8904-6bd8900de94e>

Dopp S., Hooimeijer F.L. & Maas N. (2012) *Urban Climate Framework : A System Approach Towards Climate Proof Cities*. In L. Gerrits & P.K. Marks eds. (2012) *COMPACT I : Public Administration in Complexity*. Litchfield Park: Emergent Publications. pp. 244-257

ECN & TNO (2010) *Experiment energiesprong gebouwde omgeving*. Delft : TNO.

See : <http://docplayer.nl/6346221-Experiment-energiesprong-gebouwde-omgeving-voorbeeldenboek-kleinschalige-binnenstedelijke-gebieden.html>

Fischerová Z., Tlustos P., Száková J., Sichorová K. (2006) A comparison of phytoremediation capability of selected plant species for given trace elements. *Environ Pollut*.

Gearheart R.A. and Higley M. (1993) Chapter 62 *Constructed open surface wetlands: the water quality benefits and wildlife benefits – City of Arcata, California*. In: G.A. Moshiri (Ed), *Constructed wetlands for water quality improvement*. Boca Raton:Lewis Publishers.

Groenewoud R. (2013) *Energy Self-Sufficient Neighborhoods in the Netherlands: a technical framework on the energy storage & land usage requirement for intermittent renewable energy systems*. Utrecht: Utrecht University (UU) & TNO.

See: [GroenewoudRoderickThesis.pdf](#)

Henderson K.L.D., Belden J.B., Zhao S. & Coats J.R. (2006) *Phytoremediation of Pesticide Wastes in Soil*. In *Zeitschrift für Naturforschung C. Entomology Publications* 318.

Holling C.S. (2001) *Understanding the Complexity of Economic, Ecological, and Social Systems*. *Ecosystems* (2001) 4 : 390-405

Holling C.S. (1973) *Resilience and stability of ecological systems*. Publisher: Annual Reviews.

- Hooimeijer F.L., Bacchin T., Lafleur F. (2016) Intelligent SUBsurface Quality: Intelligent use of subsurface infrastructure for surface quality. Delft: Delft University of Technology.
- Hooimeijer F.L., Puts H., Geerdink T. (2016) Successful Development of Decentralised District Heating: Application of a Theoretical Framework. In Journal of Settlements and Spatial Planning, Special Issue no. 5.
- H+N+S Landschapsarchitecten et al. (2008) Kleine Energieatlas. Utrecht: Ministerie van Volkshuisvesting, Ruimtelijke Ordening en Milieu.
- Humbeek van P. (2009) Decentrale energievoorziening onder lokaal beheer in Vlaanderen. Brussel: IST.
- Jabareen Y. (2013) Planning the resilient city : Concepts and strategies for coping with climate change and environmental risk. In Cities. Publisher : Pergamon.
- Klaas de Jong (2010) Warmte in Nederland ; Warmte- en koudeprojecten in de praktijk. Publisher: MGMC.
- Hage K., Ruitenbeek J., Zweerink K. (2005) Van Pendrecht tot Ommoord Geschiedenis en toekomst van de naoorlogse wijken in Rotterdam. Publisher: THOTH.
- Knight R.L., Clarke R.A. and Bastian R.K. (2000) Treatment wetlands as habitat for wildlife and humans. Proceedings of the 7th IWA International Conference on Wetland Systems for Water Pollution Control, Volume 1, Orlando, FL, USA.
- Lalzar (2007) An Overview of the Global Water Problem and Solutions. London: BiNET.
- Leeuw, J.J. Van der (2006) Technologie voor thuiswonende dementerenden, Kenniscirkel Domotica voor Wonen en Zorg. Utrecht: NIZW.
- Lysen E.H. (1996) The Trias Energetica – solar energy strategies for developing countries. Freiburg: Proceedings of the Eurosun conference.
- Masi F., Rizzo A., Bresciani R., Conte G. (2017) Constructed wetlands for combined sewer overflow treatment: Ecosystem services at Gorla Maggiore, Italy. In Ecological Engineering vol. 98 pp. 427-438.
- Ministry I&M (1991) VINEX, Fourth Report Extra. The Hague: Ministry I&M.
- Oswald W.J. (1995) Ponds in the twenty-first century. Water Science and Technology. Publisher: Elsevier.
- Pruissen, Olaf van. (2012) Sustains Groenewoud Roderick. Load profiles. Delft: TNO/ECN.
- Saha S. and Jana B.B. (2003). Fish macrophyte association as a low-cost strategy for wastewater reclamation. Ecological Engineering pp. 21-41. Publisher: Elsevier.
- Schleyer R., Raffius B. (2000) Grundwasserbeeinflussung durch organische Luftschadstoffe. DVWK-Materialien.
- Sijmons D. (2014) Landscape and energy: Designing transition. Rotterdam: nai010 publishers

Solecki W., Leichenko R.M., O'Brien K. (2011) Climate change adaptation strategies and disaster risk reduction in cities : Connections, contentions, and synergies. In *Current Opinion in Environmental Sustainability*. Publisher: Elsevier B.V.

Tejeda-Agredano M.C., Gallego S., Vila J., Grifoll M., Ortega-Calvo J.J., Cantos M. (2013) Influence of sunflower rhizosphere on the biodegradation of PAHs in soil. In *Soil Biology and Biochemistry* vol. 57 pp. 830-840.

Tegenlicht (2016) De doorbraak van Duurzaam.

See : <https://www.vpro.nl/programmas/tegenlicht/kijk/afleveringen/2015-2016/de-doorbraak-van-duurzaam.html>

Tharp Erin (2015) The Sensational Hive Project by World Renowned Grant Associates. Worcester: Landscape architecture Posts.

See: <https://landarchs.com/sensational-hive-project-world-renowned-grant-associates/>

Virillio P. (1977) *Speed and Politics : An Essay on Dromology*. New York: Semiotext(e)

Wardekker J.A., de Jong A., Knoop J.M., van der Sluijs J.P. (2009) Operationalising a resilience approach to adapting an urban delta to uncertain climate changes. In *Technological Forecasting & Social Change*. Publisher: Elsevier.

Rients Dijkstra and Atelier Rijksbouwmeester (2013) *Naar een gezonde relatie tussenstad en snelweg*. Atelier Rijksbouwmeester, Michel Heesen, West 8.

Xinkai Wu et al. (2013) *Electric Vehicles' Energy Consumption Measurement and Estimation*. Pomona: California State Polytechnic University.

See : https://www.researchgate.net/profile/William_Kitch/publication/267928696_Electric_vehicles'_energy_consumption_measurement_and_estimation/links/54baf7df0cf29e0cb04bd756.

websites

<http://www.yourhome.gov.au/water/wastewater-reuse>

<http://www.iridra.eu/it/fitodepurazione/applicazioni/acque-meteoriche-2.html>

[http://ec.europa.eu/transport/themes/strategies/consultations/doc/2009_03_27_future_of_transport/20090408_eabev_\(scientific_study\).pdf](http://ec.europa.eu/transport/themes/strategies/consultations/doc/2009_03_27_future_of_transport/20090408_eabev_(scientific_study).pdf)

<http://bigthink.com/design-for-good/reuniting-a-divided-city-with-an-ambitious-covered-highway-project>

<http://inhabitat.com/winning-design-turns-abandoned-italian-bridge-into-eco-village/>

<http://www.fastcoexist.com/3038134/an-algae-farm-designed-to-suck-up-highway-pollution>

<https://www.youtube.com/watch?v=Ep4L18zOEYI#t=258>

<http://www.dutchnews.nl/news/archives/2015/01/dutch-to-experiment-with-self-driving-cars-that-cooperate-with-each-other/>

<http://www.frame-architecture.com/projets/all-urban-and-landscape/dismissed-highway-solar-parc>

<https://www.youtube.com/watch?v=c4x0w7juhtw>

<http://www.curbed.com/2016/5/26/11787632/driverless-cars-will-shrink-our-roads-and-radically-reshape-urban>

<http://www.curbed.com/users/SPRoach>

<http://www.ewea.org/wind-energy-basics/how-a-wind-turbine-works/>

