

# Design of an in situ laparoscope lens tip cleaner to ensure clear and constant vision

Master thesis, 2019

Sonali Patel

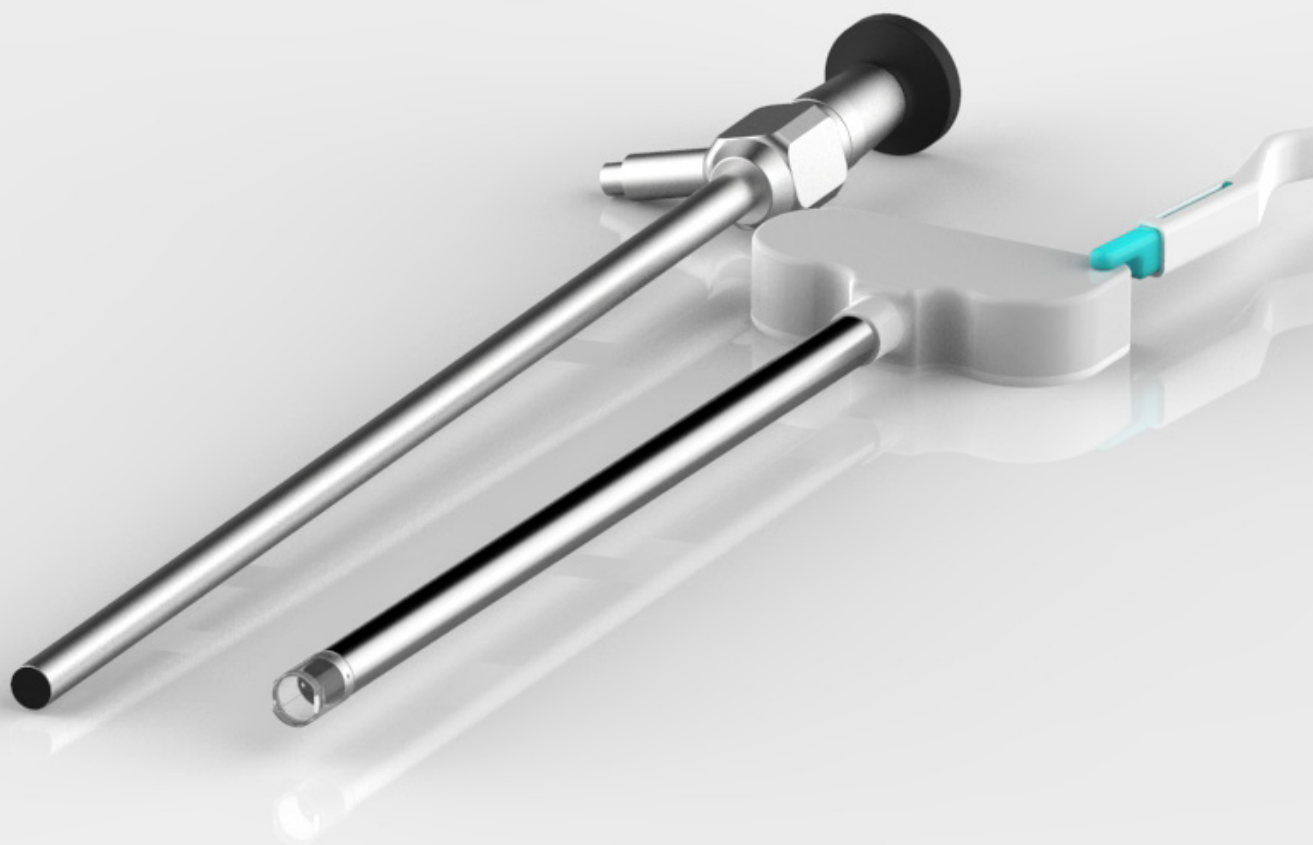



# In situ laparoscope lens shielding device to ensure constant clear vision

## Master thesis

Delft, August 2019

## Author

Sonali Patel  
Integrated Product Design (MSc.)  
soonali.p@gmail.com

## Supervisory Team

### *Chair*

Prof. dr. ir. Goossens, R.H.M.  
Professor of Physical Ergonomics, Head of Industrial Design Department  
R.H.M.Goossens@tudelft.nl

### *Mentor*

Dr. ir. Paus-Buzink, S.N., Eur.Erg.  
Lecturer at the department of Applied Ergonomics and Design  
s.n.paus-buzink@tudelft.nl

### *Company mentor*

Ir. Leon Neve  
Innovation manager at Pontes Medical  
L.V.Neve@umcutrecht.nl

## Company

Pontes Medical  
Heidelberglaan 100  
3584 CX Utrecht  
T 088 – 755 55 55  
Kamer M.01.215  
www.pontesmedical.com

## Delft University of Technology

Faculty of Industrial design Engineering  
Landbergstraat 15  
2628 CE Delft  
The Netherlands  
www.tudelft.nl

*This thesis is confidential and cannot be made public until 30th August, 2021.*



# Preface

This thesis documents the results of my graduation project done for the master track Integrated Product Design at the Faculty of Industrial Design Engineering, Delft University of Technology, The Netherlands. The title of the project is “In situ laparoscope lens shielding device to ensure constant clear vision.”

The project is carried out with Pontes Medical, situated in the premises of University Medical Centre Utrecht. Pontes Medical functions as an innovation partner for doctors and researchers in realizing medical technology for affordable, safer and better healthcare. Pontes medical provides access to clinical expertise and facilities in various fields of healthcare. Leon Neve, an innovation manager at Pontes medical mentors this project as an expert in designing and development of medical instruments. Luuk Evers also an innovation manager at Pontes Medical is also a part of this project. He provides his experience and expertise on the subject of laparoscopy. Prof. dr. ir. Richard Goossens is the chair, supervising this graduation project along with Dr. ir Sonja Paus-Buzink who is the mentor for this project.

In this project, I developed a solution for the problem of laparoscope lens contamination during the surgery. I focussed creating an easy to use solution by understanding the complex context. This thesis takes you through the journey of research, design, and development of the in situ laparoscope lens cleaning solution to ensure clear and constant vision during the surgery.



# Acknowledgements

This thesis was though my individual assignment, it has been possible with the timely help and support of many individuals. I would like to take this moment and mention all these individuals involved directly and indirectly with the project.

Starting with thanking Prof. Jos Oberdorf, who directed me to Pontes Medical for pursuing a graduation project. Your timely advice has resulted in a wonderful experience for me.

Next, I would like to express gratitude to my supervisors, Prof. Richard Goossens, for accepting to mentor my project and making the process of graduation very easy going for me. Sonja has been a wonderful mentor to me for this project. Thank you for all the right and timely guidance that helped me to keep moving, improving and learning to become a better designer.

I would like to thank the whole team at Pontes Medical – Luuk, Marlies, Leon, Oda, and Eva for accepting and welcoming me at Pontes. Special thanks to my mentors Luuk Evers and Leon Neve for their enthusiasm and guidance towards the project. Leon has been an amazing mentor. He has been actively involved in all processes of the project and has provided me with timely, prompt and right guidance. It was wonderful to work with you. I would also like to thank all the people from UMC Utrecht who participated in the project through interviews and discussions for their time and knowledge.

Next, I would like to mention and thank my support system here in Delft. Jesal and Nayantara thank you for all the mental support always and believing in my work. You guys made it easy for me. Hardik and Nirav thank you for making me feel home in these two years away from home. I would like to thank my family- mumma, pappa, and bhai. They believed in me more than I did in myself. Thank you for supporting me and my decisions in all aspects of my masters. I dedicate this thesis to your unconditional love and efforts. Lastly, I would like to thank my life companion - Akshat. You were the reason this master happened. You inspire me everyday. Thank you for bringing the best out in me always and for all the love and patience you have given me.

I gladly present my master thesis- a documentation of my work done with which I complete the master Integrated Product Design at Delft University of Technology.





# Summary

The field of minimally invasive surgery (MIS) has ushered in a new dimension of healthcare. It has helped to reduce the operating time and recovery time immensely. MIS involves the use of an endoscope, which enables the surgeon to view the interior of the human body while operating through relatively small incisions. Endoscopes are differently labelled depending on the area which is being viewed and operated. Laparoscopy is one such MIS which involves surgical procedures in the abdominal cavity through a rigid endoscope called the laparoscope.

During the surgery, the laparoscope lens gets contaminated frequently due to body fluids, bone dust, surgical plumes and fogging. This impairs the surgeon's vision. In order to maintain a clear view of the operating field, the scope has to be removed out of the patient's body to clean it manually several times per procedure. During these moments, the surgical team loses the critical sight of the operating area. This disrupts their work-flow, consumes time and creates frustration for the surgical team. Furthermore, the overall context in which the laparoscope is used is quite complex. Multiple users interact with it in a different way at different stages of its use. This has an impact on the design and manipulation of the instruments and devices used in this context.

In this project, this problem of laparoscope lens contamination has been addressed. The focus of this thesis is creating a solution to keep the lens of the laparoscope clean during the surgery to ensure clear and constant vision. Also at the same time adapting the solution to the complex context. The process of development of the solution had 4 distinct phases- research and analysis, ideation and exploration, conceptualization and development. In the Research phase, the subject of laparoscopy and the laparoscope were studied. This phase also included investigating the complex context, the stakeholders involved, identifying their needs and understanding the problem area through research activities like interviews and observations. The information gained thus was analyzed and insights were identified. These insights helped to form the design requirements of the possible solution. This was the starting point for the next phase - Ideation and Exploration. The aim of this stage was to diverge and gain a wide range of ideas. Ideation sessions were conducted to collect ideas and possible design directions were formulated. The design direction which complied with the requirements was finalized through discussions. In the Conceptualization phase, a preliminary concept idea in the chosen direction was sketched out. This preliminary concept was refined through ideations. This concept was further evolved in the last stage - Develop. In this stage, several iterations were done by building and testing mockups, discussions and further research.

The result of this thesis is a design proposal for the mentioned problem of laparoscope lens contamination which complies with the design requirements so formed by studying the complex context. This design proposal can be the starting point for engineering and prototyping phase and gaining user feedback.

# Table of contents

## **PREFACE**

## **ACKNOWLEDGEMENTS**

## **SUMMARY**

## **RESEARCH & ANALYSIS**

1. Getting acquainted
  - 1.1 Minimally invasive surgery
  - 1.2 Laparoscopy
  - 1.3 Laparoscope lens tip contamination
  - 1.4 Project approach
2. Understanding the hospital context
  - 2.1 Stakeholder analysis
  - 2.2 Surgeon's perception of the problem
3. Understanding the operating room context
  - 3.1 Workflow of the operating room
  - 3.2 Factors leading to lens tip contamination
4. Designing for the OR
  - 4.1 Laparoscope holding styles
  - 4.2 Ergonomics
  - 4.3 Ecosystem of the laparoscope
5. Understanding the market
  - 5.1 Analysing existing solution
  - 5.2 Making technology choice
6. Design vision
  - 6.1 Overview of all the insights
  - 6.2 Design requirements
  - 6.3 Assignment and project scope

## **IDEATION & EXPLORATION**

7. Ideation
  - 7.1 Ideation session
  - 7.2 Forming design directions
  - 7.3 Choosing a direction
  - 7.4 Exploring the chosen direction
  - 7.5 Refining the design direction

## **CONCEPTUALIZATION**

8. Preliminary concept
  - 8.1 Concept explanation
  - 8.2 Identifying the areas to develop
  - 8.3 Ideation on the identified areas
  - 8.4 Refined concept

## **DEVELOP**

9. The device tip
  - 9.1 Setting the dimensions
  - 9.2 Design development
  - 9.3 The device tip proposal
  
10. The device interaction
  - 10.1 Design and development
  - 10.2 Position of the trigger
  - 10.3 The device interaction proposal
  
11. The mechanism
  - 11.1 Working principle
  - 11.2 Setting the dimensions
  - 11.3 Design development
  - 11.4 The mechanism proposal
  
12. The combined design proposal
  - 12.1 Explanation of the proposal
  - 12.2 Product use scenario
  - 12.3 Tape design
  - 12.4 Material and manufacturing suggestions
  - 12.5 Costs approximation

## **CONCLUSION AND RECCOMENDATION**

### **REFLECTION**

### **REFERENCES**

### **APPENDIX**

# RESEARCH & ANALYSIS



# 01



## Getting acquainted

Minimally invasive surgeries (MIS) have changed the landscape of healthcare. Laparoscopy is one such MIS on which this thesis is focused. This chapter introduces and elaborates on the fundamentals of laparoscopy and the targeted problem area. Thereafter the approach towards the project is defined.

### 1.1 Minimally Invasive surgery

### 1.2 Laparoscopy

### 1.3 Laparoscope lens tip contamination

### 1.4 Project Approach

United States Patent Application Publication (30) Pub. No.: US 2015/0216401 A1 (43) Pub. Date: Aug. 6, 2015

SYSTEM AND METHOD FOR CAMERA CLEANING

Publication Classification

(51) Int. Cl. (2006.01) A61B 1/12 (2006.01) A61B 1/13 (2006.01) A61B 1/00 (2006.01) A61B 1/05 (2006.01)

(52) U.S. CL. CPC: A61B 1/126 (2013.01); A61B 1/05 (2013.01); A61B 1/132 (2013.01); A61B 1/0099 (2013.01); A61B 1/133 (2013.01)

ABSTRACT

A camera system, particularly for minimally-invasive surgery, comprising an optics, wherein the optics is connected to at least one transparent film and the film is removable. Further, there is provided a method for cleaning a camera in minimally-invasive surgery wherein an optics of the camera is cleaned intra-corporally by use of a cleaning device.

FIG. 10, FIG. 12, FIG. 16

Review of Techniques to Achieve Surface Cleanliness and Their Application to Surgical Endoscopy

Davey Kreeft, MSc<sup>1</sup>, Ewout Aart Arkenbout, MSc<sup>1</sup>, Paulus Wilhelmus Johannes Henselman, MSc, PhD<sup>1</sup>, Wouter R. van Furth, MD<sup>1</sup>, and Paul Breedveld, PhD<sup>1</sup>

Abstract

A clear evaluation of the operative field is of crucial importance in endoscopic surgery. During the procedure, the endoscopic lens is exposed to body fluids (eg. blood), around substance, raising fluid, bone dust or smoke. This leads to lens contamination, which in turn impairs the visual quality of the procedure. Current cleaning methods, that rely on manual wiping or a lens irrigation system are still far from optimal. To longer procedure times, drying of the lens, literature review, and reduce visual acuity potentially reducing patient safety. With the goal of finding a solution to these issues, a literature review was conducted to identify and categorize techniques capable of achieving optically clean surfaces, and to show which techniques can potentially be implemented in surgical practice. The review found that the most promising method for achieving surface cleanliness is lens irrigation system.

Keywords

SILS, single-site surgery

1. Introduction

Endoscopic vision can be obstructed due to fogging or soiling of the lens. Surveys report about 3% of the time during laparoscopic Nissen fundoplications on clearing the endoscope lens. This equals about 6 cleaning events per hour. Schoof and Gooval found that soiling of the endoscope lens during thoroscopic procedures was common. The flow of the operative field is disturbed. Contamination of the endoscopic lens that is due to distance irrigation may result in cross-infection. In addition, irrigation may cause an increase in intra-abdominal pressure, which may decrease the efficiency of the treatment course.

CHAPTER 1

Equipment in Laparoscopic Surgery

Helder Ferreira, Carlos Ferreira

Before a new instrument is used, the surgeon should know and test it. It is always better to test a device before a procedure than during it!

INTRODUCTION

Over the last 30 years, laparoscopic procedures have become standard in most surgical diseases. The rise of abdominal and pelvic laparoscopic surgery has been a true revolution in medical practice. The concept of minimally invasive approach, with all its advantages such as quicker recovery, shorter hospital stay and a far superior aesthetic results has been gaining more and more supporters among the international surgical community. The old paradigm that a big incision meant a big surgeon has dramatically changed.

The equipment and instruments for performing these minimally access procedures has, over the years, greatly improved. Following the surgeons' demands, greatly more sophisticated and efficient equipment that offers lower risk and thus higher safety to our patients.

An organized and well-equipped operating room is essential for successful laparoscopy. The surgical team and the operating room staff should be familiar with the instruments and their functions. If they are not aware of the mechanism of action, it can interfere with the surgery progression but also surgeon's anxiety and fatigue. Each instrument should be inspected periodically. Scissors, graspers, trocars, trocar sleeves are checked for loose or broken tips, even if the same instruments were used during a previous procedure.

One of the most important benefits of laparoscopy is the magnified vision offered by the optics and high definition and dissection plans. This improved image often permits a more precise surgical gesture, better hemostasis and probably less postoperative adhesions.

Almost all instruments available for laparotomy are now available in a specialized form for laparoscopy. Instruments and devices that are used in laparoscopy include the laparoscope (camera), trocars and port devices. Laparoscopic instruments for dissection, hemostasis and ultrasound. Laparoscopic instruments attempt to reproduce the effects of conventional laparotomy instruments: Grasping, dissecting, cutting and coagulation.

LAPAROSCOPY VERSUS OPEN SURGERY

Operative laparoscopy requires an advanced degree of technical skills and training. The smaller size incisions and by imaging systems of high magnification.

In spite of the same final objective, we have to distinguish the laparoscopic field from the open surgery

## 1.1 Minimally invasive surgery

Minimal Invasive Surgery (MIS) has changed the landscape of interventional surgery (Mohr, 2009). It involves conducting operating procedures in the human body remotely through small incisions. MIS has provided many advantages to the patient such as faster operating and recovery time, minimal surgical scars and lesser postoperative trauma. But at the same time, it has compromised the freedom of the surgeons in the way they perform their surgery (Stassen, Dankelman, & Grimbergen, 1999). Open surgeries provide the surgeon with direct visual and tactile feedback while operating on the patient. However, this is highly compromised in MIS (figure 1). It involves indirect manipulation of the operating field through indirect observation. The viewing field and operating field in MIS lie in different planes of action, hence it demands high hand-eye coordination skills. Further, the view of the operating field is in 2D flat images on the screen unlike in open surgery where the surgeon gets the whole 3D visual view of the organ. In such a highly compromised and critical environment of MIS, one of the essential instruments is the endoscope. The endoscope enables the surgeon to view the interior of the body while operating. This is their only window to the operating field and so if this gets compromised in any way, it can lead to disastrous results (Stassen et al., 1999).

Endoscopes are differently labelled depending on the area which is being viewed and operated ("Types of Endoscopy | Cancer.Net," 2017). Depending on the area, they also differ in dimension and physical structure to suit the working condition of that area. Laparoscopy is one such MIS which involves surgical procedures in the abdominal cavity (peritoneal cavity) through a rigid endoscope called the laparoscope.

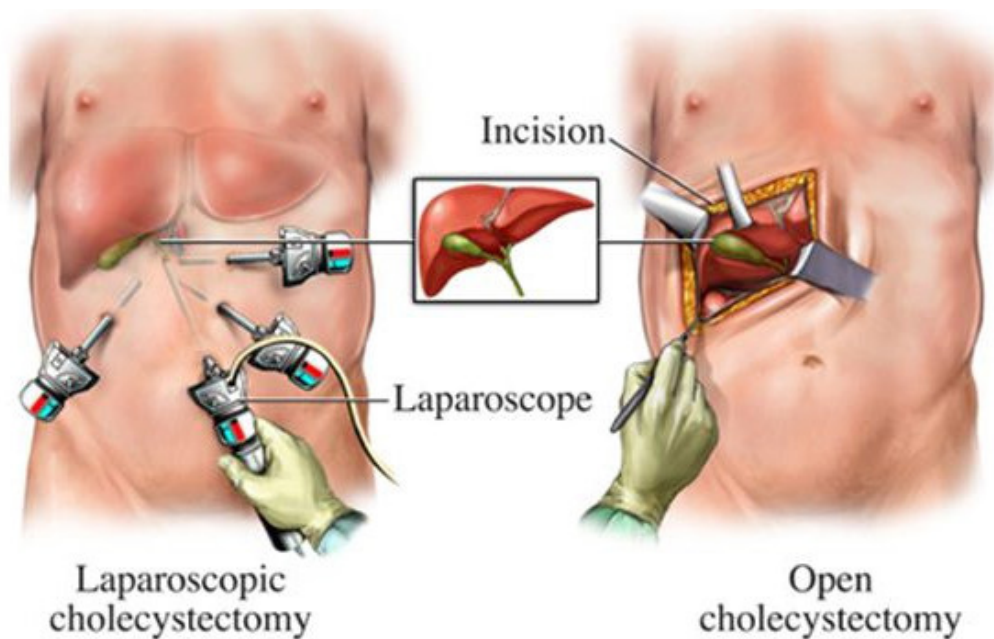

Fig. 1 (Left) Laparoscopic surgery, (right) Open surgery (laserstone, 2016)

## 1.2 Laparoscopy

Laparoscopy is the kind of minimally invasive surgery performed in the abdomen. Cholecystectomy (removal of gall bladder) is one of the most commonly performed laparoscopic procedures (Soper & Malladi, 2018). Other common laparoscopic procedures include appendectomy (removal of the appendix), hysterectomy (removal of the uterus), etc. Approximately 15 million laparoscopic procedures are carried out annually worldwide ("Global Laparoscopy and Endoscopy Devices Market, 2025 - Focus on Surgical Procedures (Cholecystectomy and Hysterectomy) and Product Types (Arthroscopes, Neuroendoscopes, Cystoscope, and Bronchoscopes)," 2018). This number is set to increase in the coming years with the innovation of medical devices in this field.



Fig.2 Veress needle Insertion (Spight et al., 2011)



Fig. 3 Trocar

### The procedure

Laparoscopic procedures are conducted in the confines of the peritoneal cavity. Access to the peritoneal cavity is gained through the Veress needle by making an incision (figure 2). Thereafter a pneumoperitoneum is created by insufflating the abdomen using CO<sub>2</sub> gas. This is done through the insufflation console. This allows for operating space in a tightly packed abdomen (Najmaldin & Guillou, 1998). Operative access in the pneumoperitoneum is obtained by trocars or entry ports which are inserted through small incisions (figure 3). These ports maintain abdominal inflation while allowing easy access for the instruments to the operative field. Through the trocars, laparoscopic instruments and the laparoscope are inserted. The laparoscope provides light through which the operative area becomes visible. A camera module is attached to the eyepiece of the laparoscope to provide the visual information of the operating field which is then displayed on a monitor in the operating room (OR). Thus the surgical procedures can be carried out (figure 4A) (Spight, Hunter, & A., 2011). The incisions for the trocars are strategically placed to allow an overview and easy access to the operative area.

### The laparoscope and the peripherals

A laparoscope is a rigid metallic tube encasing an illumination channel and a viewing channel (figure 4B). An objective lens system is present at the front end and an eyepiece lens system is present at the rear end of the tube. The illumination channel consists of glass fibers which transmit light from an external light source into the operating field. The viewing channel is a series of rods lenses that transmits the light from the operating field through the objective lens to the eyepiece thus capturing the view of the operating field. A video camera is attached to the eyepiece to continuously capture and provide a working image of the operative field (figure 4C). The video camera transmits this image to an external display monitor. Thus, the view of the operative field can be seen on an external monitor continuously by the surgeon (Najmaldin & Guillou, 1998); (Spight et al., 2011);(Ferreira, 2015).Laparoscopes are available in various types defined by overall length, diameter, angle of view and number of rods (Ferreira, 2015). The diameter of the scopes can vary from 3 -12 mm depending on the need. The objective lens at the front can provide different angles of viewing ranging from 0° to 120°. This allows viewing those sites which otherwise might not be visible to the camera in a particular position (figure 5 and figure 6). Also, scopes with different working lengths are available for different needs.



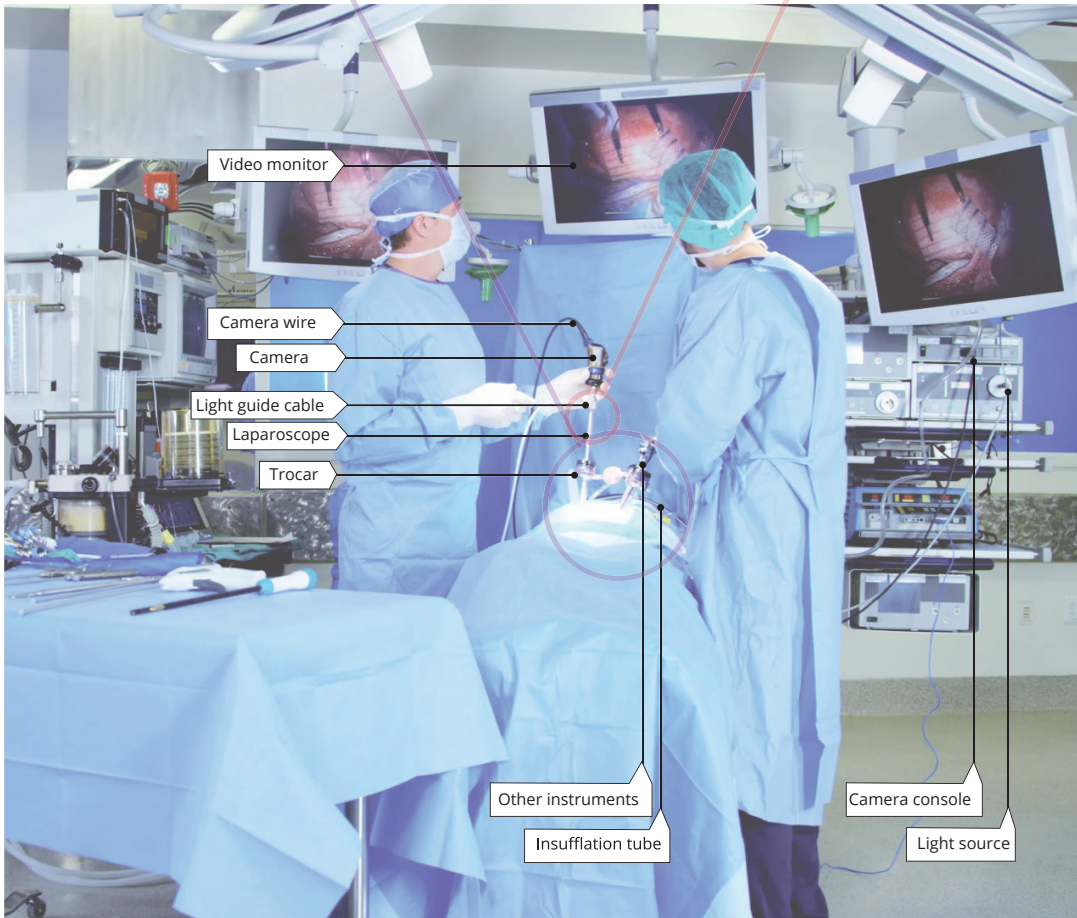
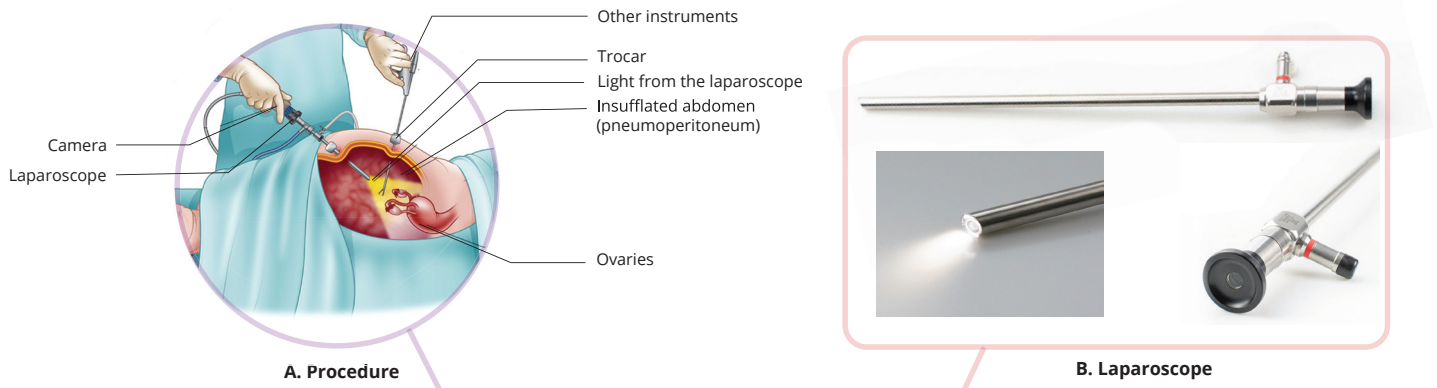

Fig. 4 Laparoscopy procedure and equipment; [image source: A ("RANZCOG WEBSITE - Laparoscopy," n.d.); B ("Storz Compatible 10mm 30 Degrees Laparoscope Autoclave Rigid Lens Endoscope Laparoscopy Instruments - Buy Laparoscopy Instruments, Laparoscope, Laparoscopic Surgical Instruments Product on Alibaba.com," n.d.)]



Fig.5 Angled tips of the laparoscopes (Spight et al., 2011)

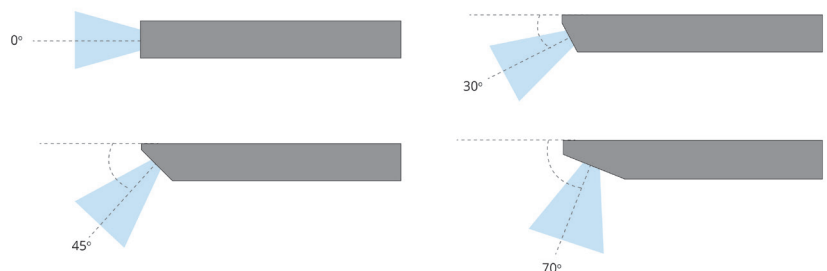

Fig.6 Viewing coverage through each angle

## Advantages and disadvantages of laparoscopy

Laparoscopy provides many advantages for the patient over conventional open surgeries. The most important aspect is that large access wounds are avoided. Therefore, the post-operative trauma for the patient also reduces. There is decreased contact with patient's body fluids and so the possibility of infections also decreases. An improved cosmetic result is thus achieved (Najmaldin & Guillou, 1998).

In contrast to the benefits, laparoscopy provides to the patient, it brings with it several difficulties in terms of operating for the surgeon. The most crucial factor is the loss of direct visual and tactile manipulation of the organs. The surgeons also face difficulties in hand eye coordination as the plane of action and plane of viewing are different. Along with this the movements of the instruments are counter intuitive and require appropriate training and experience. Laparoscopic procedures require purchase and maintenance of complicated and expensive equipment (Najmaldin & Guillou, 1998; Spight et al., 2011).

These difficulties have thus given rise to several innovations for aiding the surgeon.

## Other instruments

Different instruments are used for conducting different procedures (figure 7). They are inserted in the abdomen through the trocar. Below come of the main instruments are described in brief.

- 1) Dissecting instruments: Used for methodically cutting of tissue.
- 2) Grasping forceps: Used for manipulating the tissue and grasping the tissue during other procedures.
- 3) Scissors: Also used for dissection and available in various shapes, sometimes they also have an additional electro-coagulation feature.
- 4) Coagulation instruments: Use to coagulate bleeding vessels after dissection.
- 5) Needle holders for suturing: Used in suturing to hold the needle
- 6) Suture passer: To pass the thread in the abdomen
- 7) Clip applicators: To apply clips on the tissue to stop blood flow while dissecting.
- 8) Irrigation instrument: Used to rinse the surgical field to clean it
- 9) Suction instruments: Used to drain fluids from the surgical site.

Some instruments are hybrid where two functions can be done at the same time, for instance, irrigation and suction. Depending on the surgery, there may be extra instruments which are used.

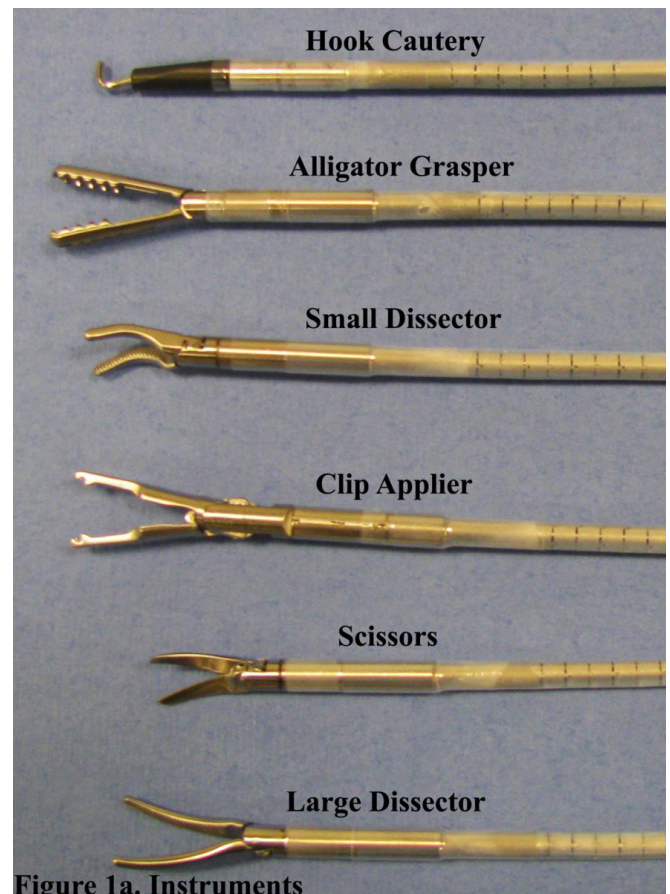

Figure 1a. Instruments

Fig.7 Basic instruments (Broderick et al., 2015)

## 1.3 Laparoscope lens tip contamination

One of the persistent problems, surgeons have to face in laparoscopy is the issue of losing vision of the operative field during the surgery resulting from a contaminated lens tip. The laparoscope provides the constant vision of the operative field. However, due to certain procedures and the matter present in the abdomen, the lens tip gets dirty (figure 8). This results in blur, hazy or blocked vision. The surgical team loses the sight of the operative field. These contamination events may occur several times per procedure. In critical situations, the view of the operating field is of utmost importance to keep everything in control. During these times, if the view gets impaired due to contamination, it can lead to disastrous situations.



Fig. 8 Laparoscope lens tip contaminated due to blood (Aarts, 2015)

In order to maintain a clear view in the event of contamination, the surgical team sometimes rubs the lens against a nearby soft tissue or most often they fully remove the laparoscope out of the patient's body and manually clean the lens tip by wiping it with gauze and defogging solution or distilled water (figure 9). This cleaning action disrupts the workflow of the surgical team and this unnecessary disruption may cause frustration to them. Furthermore, it consumes crucial operating time and most importantly it can be dangerous for the patient (Kreeft, Arkenbout, Henselmans, van Furth, & Breedveld, 2017).

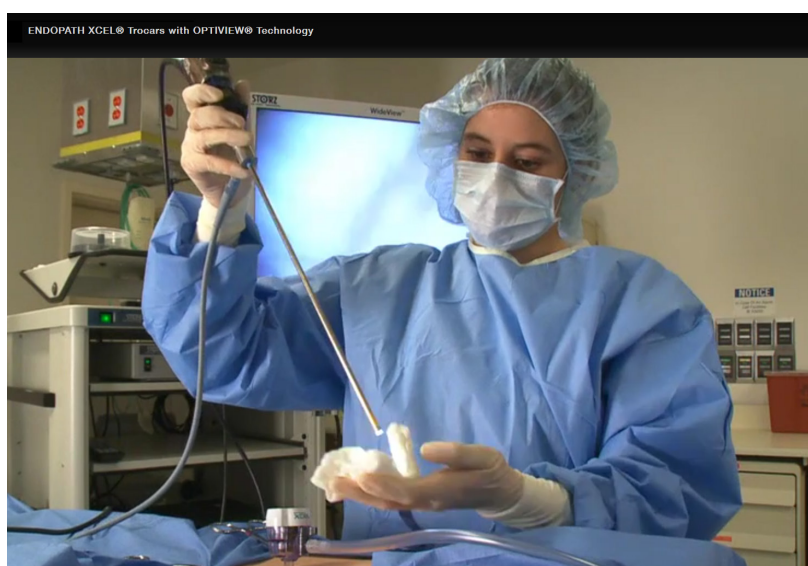
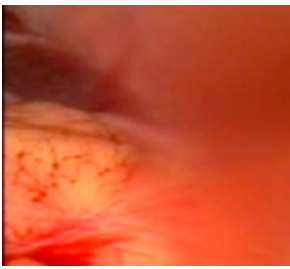

Fig.9 Manually wiping the lens tip with gauze and defogging solution ("ENDOPATH XCEL® Trocars with OPTIVIEW® Technology | Ethicon," n.d.)

## Causes

The operative field is comprised of various kinds of matter such as body fluids (e.g. blood), tissues, fatty substances, etc. (Kreeft et al., 2017). When the laparoscope accidentally comes in contact with tissue or fatty substance, smudges appear on the lens tip (figure 10A). This makes the vision blurry. During some surgical procedures, the body fluids and solid substances get splashed on the laparoscope, for instance during rinsing of the operative field, blood gets splashed or during cauterizing a fatty tissue particle may fly on the laparoscope. These splashes are stubborn. The liquid droplets and solid substances adhere to the lens tip (figure 10B). This results in a blocked vision for the surgeons. Surgical smoke is another reason for an impaired vision. The smoke is caused during the cauterizing procedure. This smoke accumulates in the abdomen and causes hazy view (figure 10C) (Kreeft et al., 2017). Another factor often leading to impaired view is fogging on the lens tip. There is a difference in temperature between the inside of the abdomen and the laparoscope (Lawrentschuk, Fleshner, & Bolton, 2010). The temperature and humidity inside the abdomen are higher than outside. Thus when the relatively cold laparoscope is inserted in the patient, condensation occurs at the tip and the view becomes foggy (figure 10D). This is typically also termed as laparoscope lens fogging.

Thus, it is clear that preventing contamination to occur is not possible considering the environment in which the laparoscope has to function. This environment cannot be altered. However, upon contamination, the tip can be cleaned in situ.



A. Smudge due to fat or tissue (Aarts, 2015)



B. Blocked view due to blood splash

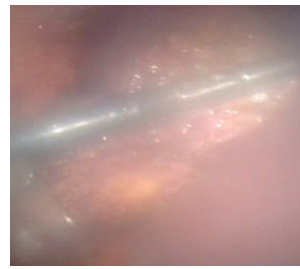

C. Hazy view due to surgical smoke (Aarts, 2015)

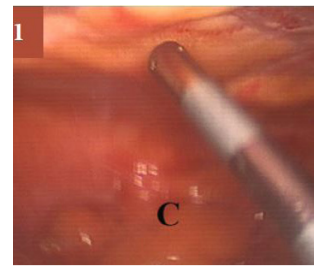

D. View unclear due to fogging (Jategaonkar, Jategaonkar, & Yadav, 2016)

Fig. 10 Causes of laparoscope lens tip contamination.

## Frequency of occurrence and risk involved

The frequency of laparoscope lens contamination highly depends on the kind of surgery and the kind of procedure being carried out within the surgery. In literature, two such studies can be found which quantify the occurrence of laparoscope lens contamination by calculating the number of scope removals from the body of the patient to clean it (Aarts, 2015; Abbitt, Khallouq, & Redan, 2017).

A study by Aarts (2015) shows that on an average the scope was withdrawn 1.8 times per surgery out of 55 observed surgeries. However, the study also points that in 19 surgeries out of 55 the surgeons opted to not withdraw the scope for cleaning and continue the procedure. This does not necessarily mean the vision was clear. Research by Abbitt et al. (2017) shows an observational study of 52 laparoscopic surgeries. They recorded an average scope removal of 1.96 times per procedure for cleaning. 9 surgical procedures did not involve removal of the scope for cleaning. Their study also mentions the positive relation between the increase in laparoscope withdrawals and the increase in estimated blood loss and operative time.

From these studies, we can conclude that the frequency of scope withdrawal and frequency of lens tip contamination are not related. Not every contamination event will lead to a cleaning action. This shows that many times the surgeons manage to proceed with an obscure vision until it doesn't bother much. They do this maybe to maintain the flow of the surgery and avoid the frustration of removing and cleaning. This is risky and would require experienced surgeons to handle the situation. This may not be the case all the time.

## Lack of potential solutions

Since the advent of MIS, this problem has been existent. Numerous solutions have been proposed in the literature and are also available in the market to tackle this problem with alternative lens cleaning techniques, in situ or outside the patient's body. Kreeft et al., 2017 studied and compared these different cleaning methods for endoscopes like irrigation and fluid inflow based solutions, mechanical solutions like wipers for the lens tip, defogging and scope pre-warming solutions or solutions requiring changes to the existing laparoscopes or trocars. Their research shows that they are yet far from ideal and hence none of them have been successful to address this problem fully. Several reasons point towards their underutilization, such as their complex usage involving extra preparation, unergonomic for the surgical team, lack of evidential data about their credibility, unawareness of their availability and unaffordable solutions for the hospitals (Kreeft et al., 2017)(Manning et al., 2017).

These reasons can be related to the complex context in which the laparoscope is used. Multiple users are involved at various stages of a laparoscope's journey of use. All of these stakeholders interact with the device in a different way depending on their role. The proposed solutions have not been able to perform efficiently throughout this journey of laparoscope's interactions. In other words, they are not holistic solutions.

## Complex context of use and stakeholders involved

As mentioned earlier, the context in which the laparoscope is used is quite demanding involving many stakeholders. For this project, UMC Utrecht is taken as a case study. The hospital procures these medical devices from the suppliers, the technical team tests them and sets up their surrounding infrastructure, the scrub nurses prepare them before the surgery, the surgeons use them during the surgery, after the surgery, the sterilization department reprocesses it and stores it for the next use. These order of these steps may vary depending on the hospital and its organization, however, the general steps involved in a product's life-cycle in a hospital are summarized below in figure 11.

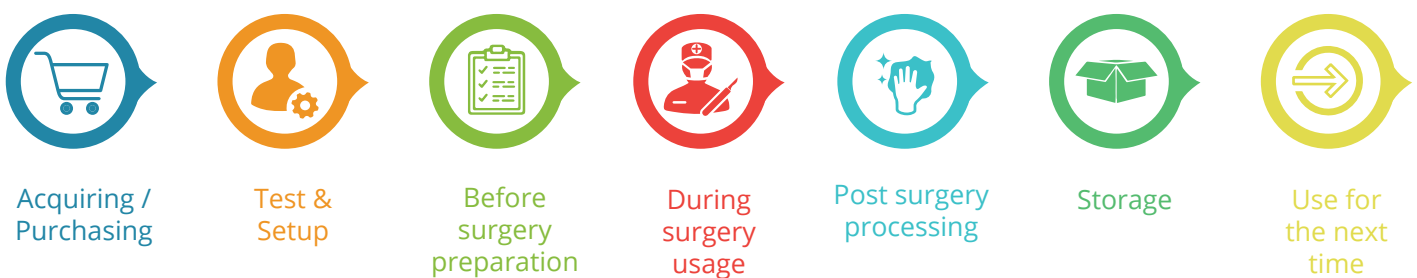

Fig. 11 Steps in the journey of a medical device.

In this whole journey, every step involves a different stakeholder. Each stakeholder interacts with the device with a different perspective depending on their job. Therefore, their needs and expectations from the device also vary. The hospital wants standardized devices and a good package from the supplier, the surgeons want an efficient and ergonomic solution, nurses want devices which are easy to prepare and operate, and the sterilization team needs easily cleanable devices. However, everyone's ultimate aim is the patient's safety. These contextual demands affect the functioning and the design of the devices. They also decide on the adoption of a particular solution over other in the hospital context.

Thus, the new solution would have a tedious task to be efficient and ensure a clear vision always and also at the same time manage this complex network of stakeholders.

## Conclusion and problem statement

The problem of laparoscope lens contamination has been existent since the start of MIS. The operative environment of the abdomen is the cause of contaminations of the lens tip and the subsequent vision impairment for the surgeons. Different matter in the abdomen causes different kinds of contamination. Solid contaminants stick to the lens tip are very stubborn to remove. Frequency of occurrence of contamination is dependent on many factors like the kind of surgery, kind of procedure, experience of the surgeon, etc. However, the scope is not cleaned on all contamination events. With the increase in the number of laparoscopic procedures, this issue also multiplies. Though happening for a short periods contamination of laparoscope is a frustrating moment for the surgical team and risky for the patient. The solutions proposed for this issue do not satisfy the surrounding factors of the context. Based on this, the problem area can be summed up as -

“There is not yet an in situ, laparoscope lens tip cleaning solution which efficiently provides clear constant vision during the surgery and successfully satisfies all the interactions involved in the complex laparoscopic context.”

## 1.4 Project approach

Based on the problem area, a preliminary design brief for this project was formed and is described below – “The design brief to develop an in situ laparoscope lens cleaning solution, which is easy to use for the surgical team and can adapt to the complex context of the hospital.”

A solution in the complex context of laparoscopy will be fruitful when there will be a balance between, the hospital, technology and the user aspects of the device (figure 12). However, when noticed, the existing and the proposed solutions seem to be dominated on the technology side, with little emphasis on the other two aspects.

These existing solutions seem to be born out of technology research rather than starting from the actual clinical need. This points out that in order to create a holistic and applicable system for both surgeons and hospitals, there is a need for a clinically driven approach rather than only a technological approach. Stassen et al., (1999) also stress the need of clinically driven approach for device development in the field of MIS as it will help to understand the fundamental needs of the surgeons and thus define the specifications for a device in a much better way. This will ensure better adaptability of the solution by the hospital and the surgeons. Thus the design brief is approached by first understanding the clinical and contextual need.

The project will be tackled by understanding all the contextual factors such as stakeholders involved, their needs and demands, analyzing existing solutions and technologies surrounding the problem and observing the surgeries in the OR to understand the work-flow, ergonomics and actual need related to the problem of laparoscope lens contamination. The subsequent chapters elaborate on these studies.

Based on them, a concrete assignment and the scope of the project is defined.

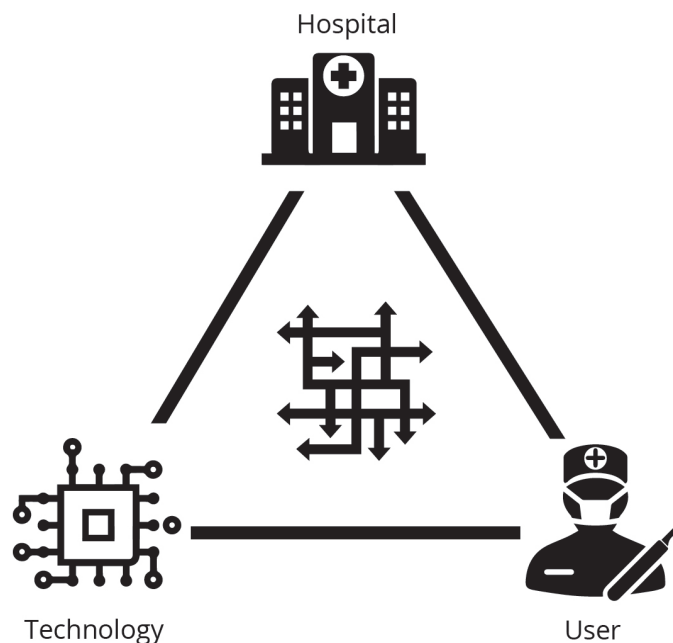

Fig. 12

# 02



## Understanding the hospital context

The context of hospital involves many factors which dictate the way the medical devices are used in the hospital. These factors include the stakeholders, their roles and needs, and the protocols to be followed. It is essential to understand these factors and their influence in order to identify the actual clinical need and thus the requirements of the future solution. This chapter discusses these stakeholders and their wants with respect to the problem of laparoscope lens tip contamination.

### 2.1 Stakeholder analysis

### 2.2 Surgeon's perception of the problem

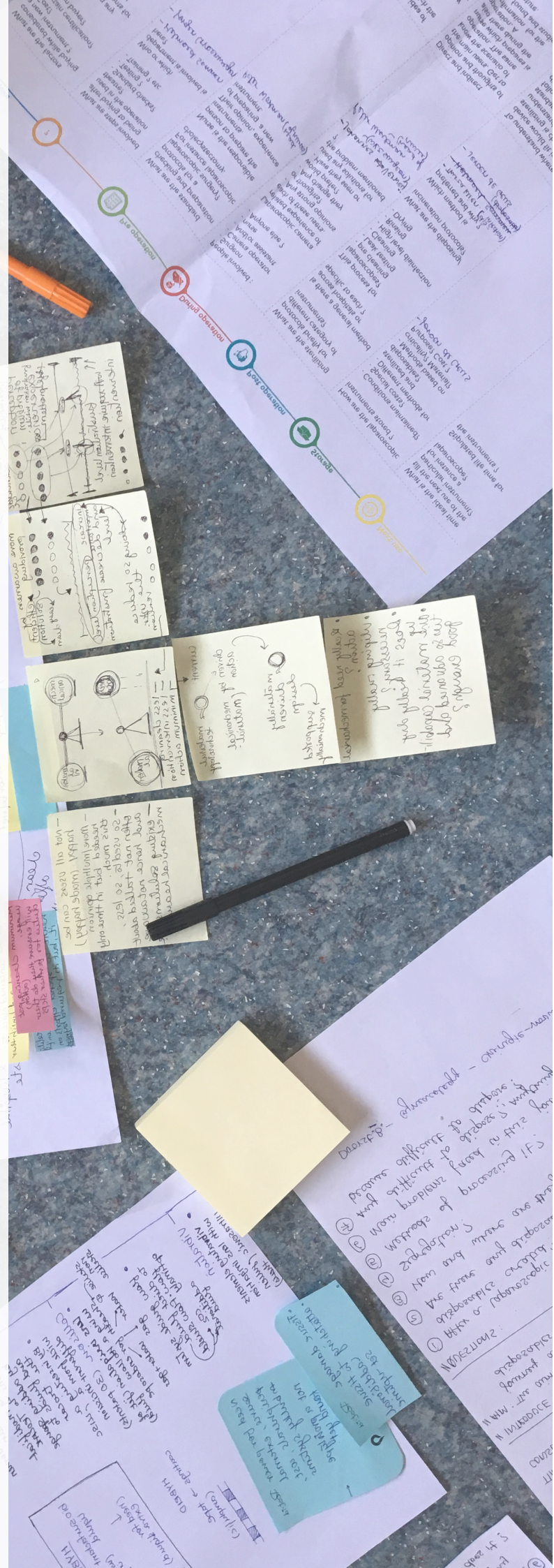



## 2.1 Stakeholder analysis

Laparoscope is handled by various stakeholders during its journey in the hospital. Stakeholders involved in each step described in figure 11 were identified within UMC Utrecht. Interviews were the chosen method to learn about their thoughts and needs with respect to the problem of laparoscope lens tip contamination. In total 11 stakeholders were recruited. The roles of the stakeholders, the department they belong to and the range of information received is depicted in figure 13. Semi structured interviews were conducted with them. Informed consents were taken before the start of the interviews for audio recording the conversation. Few set of questions were prepared beforehand for every interview. Some questions were made on the spot based on the discussion. These question sets were tailor-made for each stakeholder depending on their roles. These questionnaires can be found in appendix B. Each interview was conducted for a duration of 30 minutes. The general flow of every interview can be described as follows -

Personal and project introduction, Explaining the purpose of the interview, Understanding their roles, Understanding their view on the problem of laparoscope lens tip contamination., Gaining their opinion on a few existing products, Understanding their needs regarding the mentioned problems, Summing up with their final thoughts on the problem and project, Gaining further relevant contacts.

During the interviews, the above mentioned topics were covered however, many times questions were build up on the ongoing topic of discussion to gain more information. This gave those insights which were previously not thought of. Two A4 printouts describing the problem and few of the existing solutions were used as a medium to show, explain and discuss the scenario. They can be found in appendix C. Each interview was later transcribed and interpreted. These transcripts and their interpretations can be found in appendix D. With each interview, the developed map with all the steps in figure 13, was populated to see the information gaps and how to cover them with the next interviews. The interpretations from each interview were used to create a journey map of a new medical device from its purchase until its post process after surgery (see figure 14).

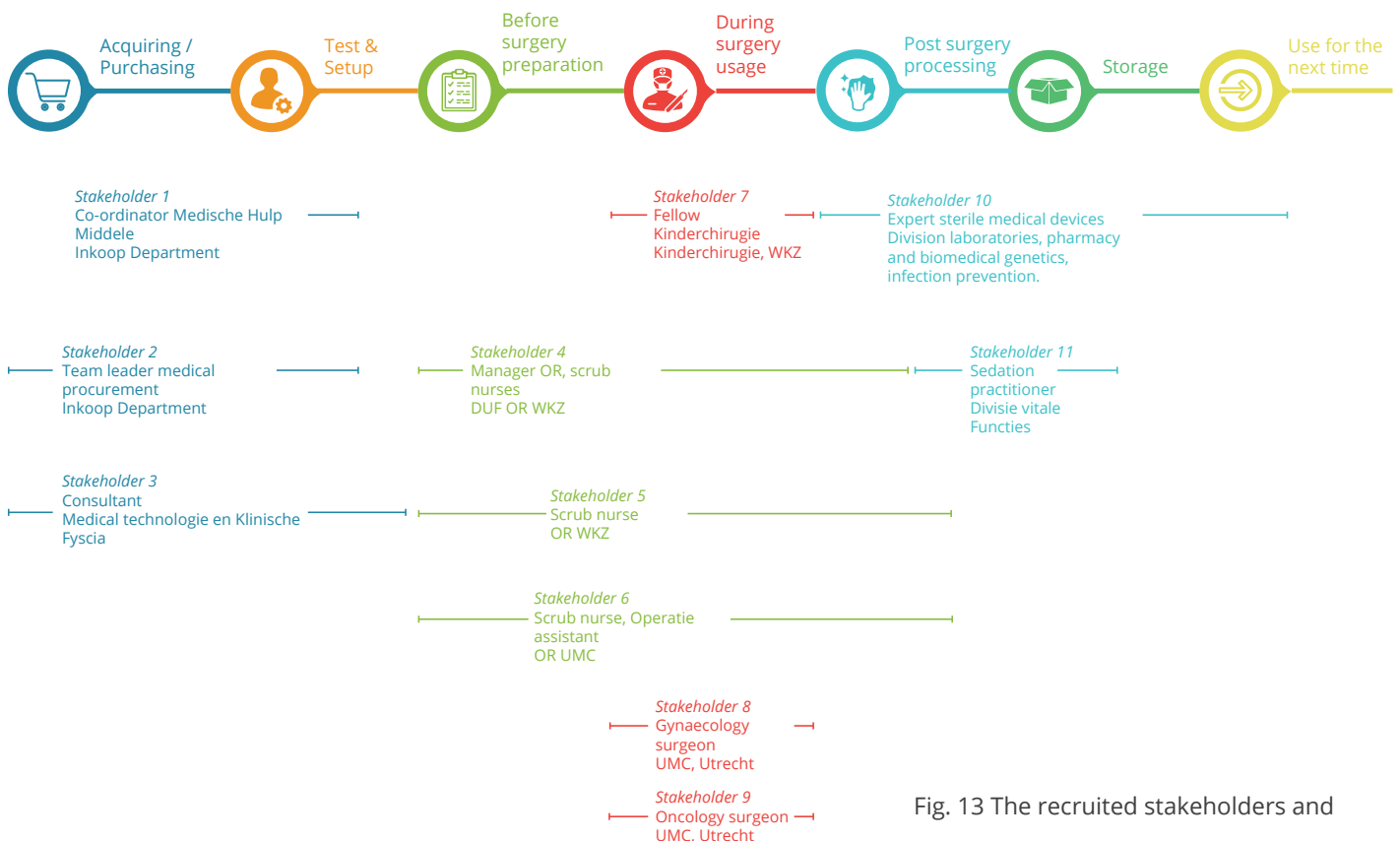

Fig. 13 The recruited stakeholders and their roles.

## **Journey of a medical device in the hospital**

The need for a new solution is born from the clinical side when surgeons encounter a particular problem. The surgeons have to collectively prove the need for a new solution to their department. Each department is responsible for its own procurement of new medical devices. Hence they are the ones who will sanction the budget for the same.

When the need is proven valid, a new technology introduction is initiated. A team is formed, with a dedicated project leader. The team also comprises of the user i.e. the surgeon. A new technology dossier is created with a list of requirements and a preliminary market survey, etc. The Inkoop or purchasing department then takes it forward, to look for suitable suppliers for their needs. They become the buyers and the team becomes the client. The purchasing department does have preferred suppliers and they try to standardize the equipment they buy to their existing equipment as much as possible. However, when the need demands a different device from a different supplier or company, they do investigate it further. A risk analysis is prepared for this new incoming technology. They analyze the changes which will happen in the existing work-flow because of this new introduction. Testing of devices are conducted before buying, surgeons are involved here. As they are going to be the users, their opinion is considered with importance. Along with the solution, the buyers also look for supporting infrastructure provided such as maintenance, cleaning systems, training of personnel, etc. The bigger and costlier the solution, the more time it will require to be introduced. After this lengthy process, when a suitable solution is found, it is purchased. Then starts the setup of the solution and its infrastructure. They train the personnel who will use the device. They set up the cleaning facilities. Safety aspects are particularly reviewed. And after careful analysis, it is finally released for use in the hospital.

Before the surgery, the scrub nurses prepare all the instruments, devices and consumables needed for the surgery. They carefully prepare everything in a sterile environment in the preparation room. Here they have that much time to prepare everything for a particular surgery, as much as the time is taken by the anesthetic team to prepare the patient to sleep. It could be less or more, depending on the kind of surgery. They have monitors in the preparation room to keep track of the patient. Once they have the patient ready, they go in the operating room. The surgical team may comprise of one or more surgeons, a resident (a doctor learning to be a surgeon), scrub nurses - sterile and non-sterile, anaesthesiologists, interns and other members depending on the need of the surgery. During the surgery, the team is focused on their main tasks and always see to it that all goes well. The team maintains calm throughout to function better. The sterile scrub nurse assists the surgeon in the best possible way so that he can perform his duties. The surgeon demands co-ordination from his team. The laparoscope during the surgery is handled by the surgeon or resident depending on the situation. Sometimes, the scrub nurse also handles the scope. On events of contaminated scope, it is removed from the patient and cleaned by the scrub nurse using defogging solution and gauze.

After the surgery, the scrub nurses collect the disposable waste and the instruments which need to be reprocessed. The waste is taken out of the OR from the other side into the waste room, where all the special hospital waste has been collected for incineration. The instruments which are to be reprocessed are sent to the sterilization department. Here they undergo cleaning as per protocols which are set by the manufacturer. After the cleaning and disinfecting cycle, they are stored in predefined conditions to maintain the sterility for the next use.

This device journey shows the possible route of the new solution in the complex context of laparoscopy and what factors could affect it. Through this journey, what each stakeholders would want and what would they dislike at each step of product use could be deduced. These are summarized in the next sub chapter.

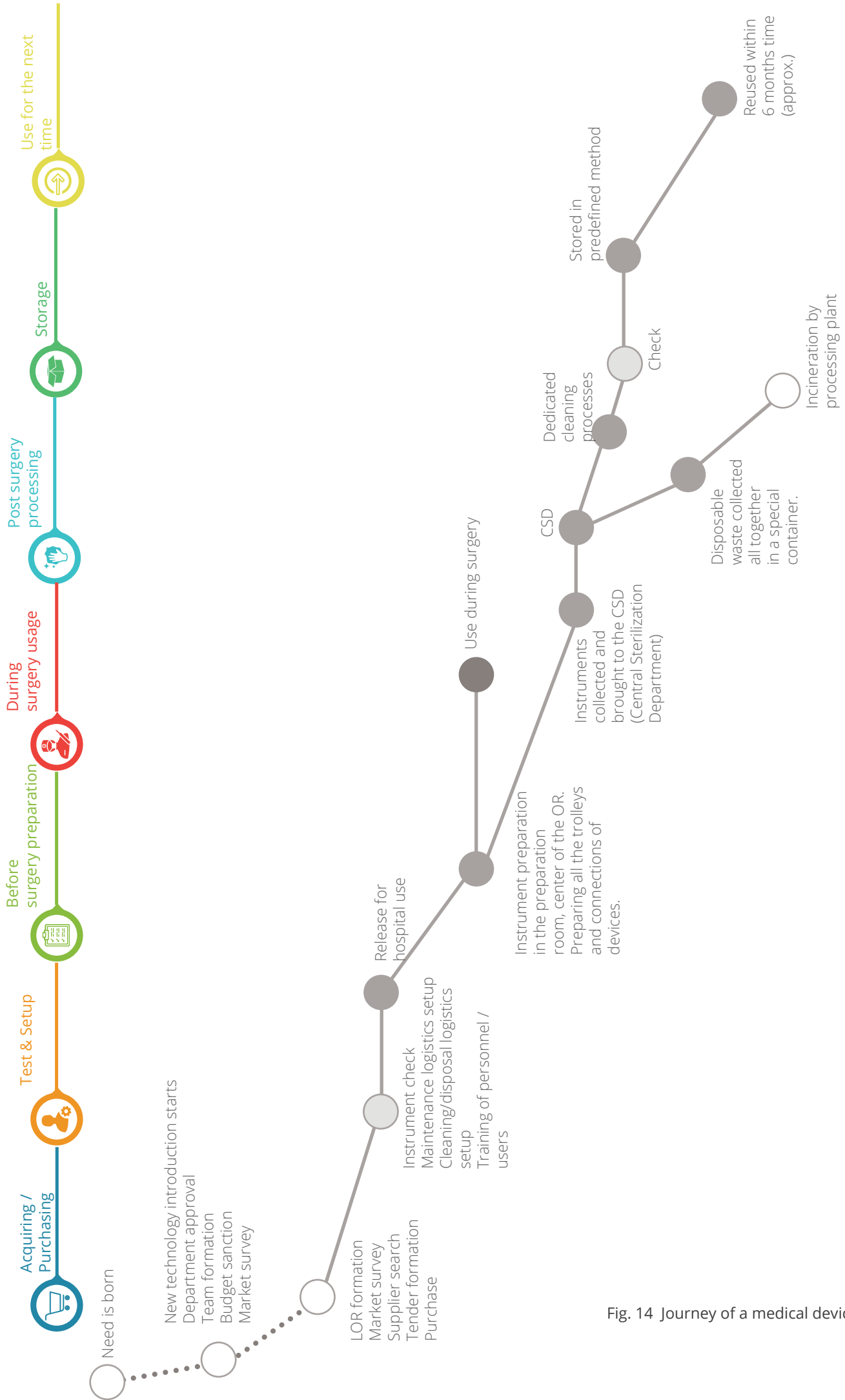

Fig. 14 Journey of a medical device.

## Wants and dislikes of the stakeholders

Wants - green boxes and Dislikes - red boxes



Acquiring /  
Purchasing

### Purchasing / Inkoop department

They want an enthusiastic team to head the new product introduction, with experts and a motivated team leader. They want to meet the user's needs but at the same time, they also want a good deal (overall), as standardized as possible, complying to their existing equipment and have the supporting infrastructure also provided by the supplier.

They do not want to lose time. They have to face a time loss if the right people are not included in the team, if an appropriate budget is not there, if the need for the new technology is not proven well and if they have a non-enthusiastic team.

### Surgeons

They want smoother operations and to be able to focus only on their task.

They do not want to go through the lengthy process of device acquiring alone. They don't want more work besides their usual workload, for a problem which they perceived small in comparison to the whole surgery.



Test &  
Setup

### Testing & Setup

The testing department wants all the infrastructure to be in place and have certified and trained staff who is ready to use the device safely.

They do not want unsafe situations with the new device.



Before  
surgery preparation

### Surgeons

Surgeons do not play an important role in preparation before the surgery. This is completely handled by the scrub nurse.

### Scrub nurses

They want to make sure that everything is ready to assist the surgeon in the best possible way and focus on maintaining sterility. They also want good quality instruments to do their job better and not compromise. They want to prepare everything before the surgery in time. They would prefer a standard method to clean the lens tip for all surgeries rather than remembering each surgeon's need.

They do not want unnecessary delays or breaks in their work-flow of preparation. And they do not want bad instruments.

If the proposed solution is smaller, less complicated and meets the user demands, it will lead to faster-acquiring process and quicker budget approvals. Thus they can have a faster introduction of the new technology.

Nurses will have a better work-flow if the solution blends in their current way of functioning. Hence, requiring less learning curve, minimum preparation time and easy to use.



## During surgery usage

### Surgeons

They want a cleaner view all the times, pay more attention to their task rather than cleaning the tip. They want better coordination and anticipation by the team to avoid contamination. In the case of contamination, they want to resume quickly with a clean view.

They do not want unnecessary interruptions in their procedure. They do not want to be dependent on the nurses for cleaning.

### Scrub nurses

They want to assist the surgeon in best possible way at all times during the surgery. They want to be quick and attentive.

They do not want to waste time during the surgery.



## Post surgery processing

### Sterilization department

They want easily cleanable instruments, which can also be easily checked for their cleanliness.

They do not want small internal moving parts difficult to clean and which they cannot give surety about.

### Disposing department

They would want to be able to segregate it for better disposal/further recycling into plastic/metal/PMD.

They do not want unnecessary hybrid waste.

### Scrub nurses

They want to clean up and send instruments to the concerned department and set up for the next surgery quickly.

They do not want to have any delay. They have a daily schedule with all the surgeries they have to assist, so they want to be prepared for all them.

With minimum interaction with the device, a continuous workflow can be achieved. The solution has to ensure efficient cleaning with less action, and not depend on the nurse anymore. The cleaning action has to be quicker than the time taken currently.

Avoid small, internal moving parts and tiny crevices in design, if it's to be made for reprocessing or make it easy to disassemble. In the case of disposable, it needs to be easy to segregate for better further material processing.

## 2.2 Surgeon's perception of the problem

In the stakeholder analysis, all the stakeholders were analyzed together. The most important and influential stakeholder is the surgeon. They are the actual users. Therefore, it is essential to understand their wants in details and their perception of the problem. Previously only three surgeons were interviewed. Hence to gain an opinion of a larger group, the questionnaire method was chosen. The aim of this study was to understand the frequency of a similar opinion. This would help to understand the depth of the problem. A set of objective and subjective questions were drawn up to gather information from the surgeons regarding the problem of laparoscope lens tip contamination. The sample questionnaire can be found in appendix E.

Five surgeons from different departments who performed laparoscopic surgeries were reached out through an assistant. Not all of the surgeons mentioned their department hence these demographics could not be captured. The answers in the questionnaires were analyzed to understand the similarity and differences in the opinion and frequency of certain opinion. Unfortunately, the relation between the surgery department and the opinion could not be found as that information was not provided.

The filled in questionnaires can be found in appendix E. The overview of the answers is summarized in the figure 15.

From this overview, several conclusions can be drawn. On average, the laparoscope gets contaminated 4.4 times per procedure. Smudging from fats or tissue was the most cited reason for lens contamination. Another aspect is even though the 2 surgeons said it does not bother them or bothers them slightly, they still have often cleaning cycles. This may mean they are too used to the cleaning method and it has become their habit now. Most of the surgeons reported that they clean the tip often but not always. This indicates that a cleaning action is carried only when the need is severe. They manage to continue the procedure with partial vision. The overall emotion during the contamination event remains disappointed, even in the case when it does not bother the surgeons. Gauze and anti-fog solutions are used in UMC Utrecht to clean the lens tip. 4 out of 5 surgeons are open to a new solution for this problem. Almost all the surgeons are not aware of any other solutions for this problem apart from warming and anti-fog solutions.

Thus it can be concluded that the surgeons, in general, perceive the problem to be very small. When compared to the complexity of the whole surgery, it indeed is small. However, the problem being small gives rise to the peaks of frustration and disappointed feeling in the surgeons. Since they are quite used to this, they overcome this feeling easily and continue with the procedure until the next peak of frustration arises. Therefore, for a smooth flow of the surgery, the solution should help to keep the vision clear at all times with a small intervention. And the solution should be very simple in nature to match its perception in the surgeon's mind. An over complicated and high tech solution might feel an overkill to the surgeon for the purpose it is intended for.





	Number of surgeries per week	Frequency of contamination per surgery	Major reason for contamination	How much does it bother?	Feeling during contamination	Frequency of cleaning during contamination	Method of cleaning	Aware of any solutions for the problem	Thought of introducing new technology for this problem	Would u like a new solution?
<b>Surgeon 1</b>	2-3 times	5-8 times	Smudging (fat or tissue) , Blood splash	Slightly but its okay		Sometimes, it depends	Cloth and antifog liquid		no	Maybe, if it saves time
<b>Surgeon 2</b>	3	1-2 times	Smudging (fat or tissue) , fogging	no it does not		often but not always	gauze and anti fog	warming methods	no, not really a major issue	yes, no specific needs
<b>Surgeon 3</b>	3	4-6 times	Smudging (fat or tissue) , fogging and blood splash	yes it does		everytime it gets contaminated	gauze and anti fog	only solutions to prevent fogging like heating elements		yes, against fogging a filter to prevent smudging
<b>Surgeon 4</b>	3-5 times	5-10 times	Smudging (fat or tissue)	Slightly but its okay		often but not always	gauze and anti fog	does not work. Gets bloody after few cleanups and gauze is needed any way	no	yes, something that does not increase the size of the camera, integrated not separate
<b>Surgeon 5</b>	3	3 times	Smudging(fat or tissue)	yes it does		often but not always	nurse cleans it	no	no	yes, nut no idea

Fig. 15 Overview of questionnaire results

# 03



## Understanding the operating room context

The operating room involves many critical factors which affect the way the surgery is performed and the instruments and devices are used. To get first hand insight of these factors, observation sessions were conducted. Through observations, the processes in the operating room and the reactions and interactions between the surgical team during an event of laparoscope contamination can be studied. This chapter gives detailed account of the observations carried out.



### 3.1 Work-flow of the operating room

### 3.2 Factors leading to laparoscope lens tip contamination



## 3.1 Work-flow of the OR

A day's permission was obtained to visit the OR and observe laparoscopic surgeries. The kind of surgeries to be observed depended on the ones which took place on that day. Three laparoscopic surgeries were observed. The first one was a hysterectomy (removal of the uterus) done with conventional manual laparoscopic methods. The second surgery was also operating on the ovaries. It was semi-manual surgery using Mofixx (device developed by Pontes Medical to hold the laparoscope in position while operating so that the surgeons can be hands-free and the scope is held steadily) and the third surgery was a robotic laparoscopic surgery for removal of the oesophagus due to cancer. This was done using the Da Vinci robot. During each surgery a time log was maintained, noting the occurrence of a certain event with respect to the time in a diary. Quick sketches were made during certain situations to capture the moment.

From the observation notes, the general steps involved in laparoscopic surgery were sketched out. Starting from the preparation of the surgery until the end, when they clean up the operating room, the whole process was noted. Figure 16 shows this process. The number in the figure relates to the number of the point for its description.

1) The layout of the operating room is shown here. It is concentric in its layout, with the sterile preparation room with all the instruments and devices at the center. This preparation room is rectangular and has many racks with instruments sets and trays stacked under their respective labels. Depending on the day's schedule of surgeries, all the instruments are brought and kept here in prior. Surrounding this room are the various ORs. The ORs have two entrances. One from the preparation room and one from the outer corridor. The outer corridor runs around this main centrum and is connected to the garbage room, the holding (reception), the recovery room for patients and the entrance to the changing room for surgeons and nurses.

2) The day starts at 8:00 am where the team formed (surgeons, residents, scrub nurses, anesthesiologists) for the day meets in their designated OR for the day's briefing. The surgeons or resident briefs about what all the surgeries will be performed, any specifics about them, surgeons involved, etc.

3) After the briefing, the scrub nurses go to the preparation room. The patient is brought in the OR and the anesthesiologists start to prepare the patient to sleep.

4) While the patient is being slept, the scrub nurses start preparing for the surgery in their sterile dock. One of the scrub nurses stay non-sterile, and the other one dresses to be fully sterile. The non-sterile scrub nurse helps the latter to prepare everything by handing over items without touching. They lay down the green sterile sheets carefully on separate trolleys and place all the instruments, consumables, liquids, etc. they would need during the surgery. While doing so they keep a constant watch over the monitor which shows the status of the patient inside. They try to prepare to utmost detail so that they don't have to do that when they are inside the OR, for instance folding and fixing the gauze in the scissor-like instrument. They are so experienced, that they know everything by the back of their hands.

5) Once the patient is asleep, the scrub nurses enter in the OR with the trolleys. The area around the patient is arranged ergonomically with trolleys, lights, screens all in easy reach. They position the patient in the required manner. They prepare a sterile field around the operating area by covering the patient with green sheets. Everything is kept handy and the surgery can be now started.

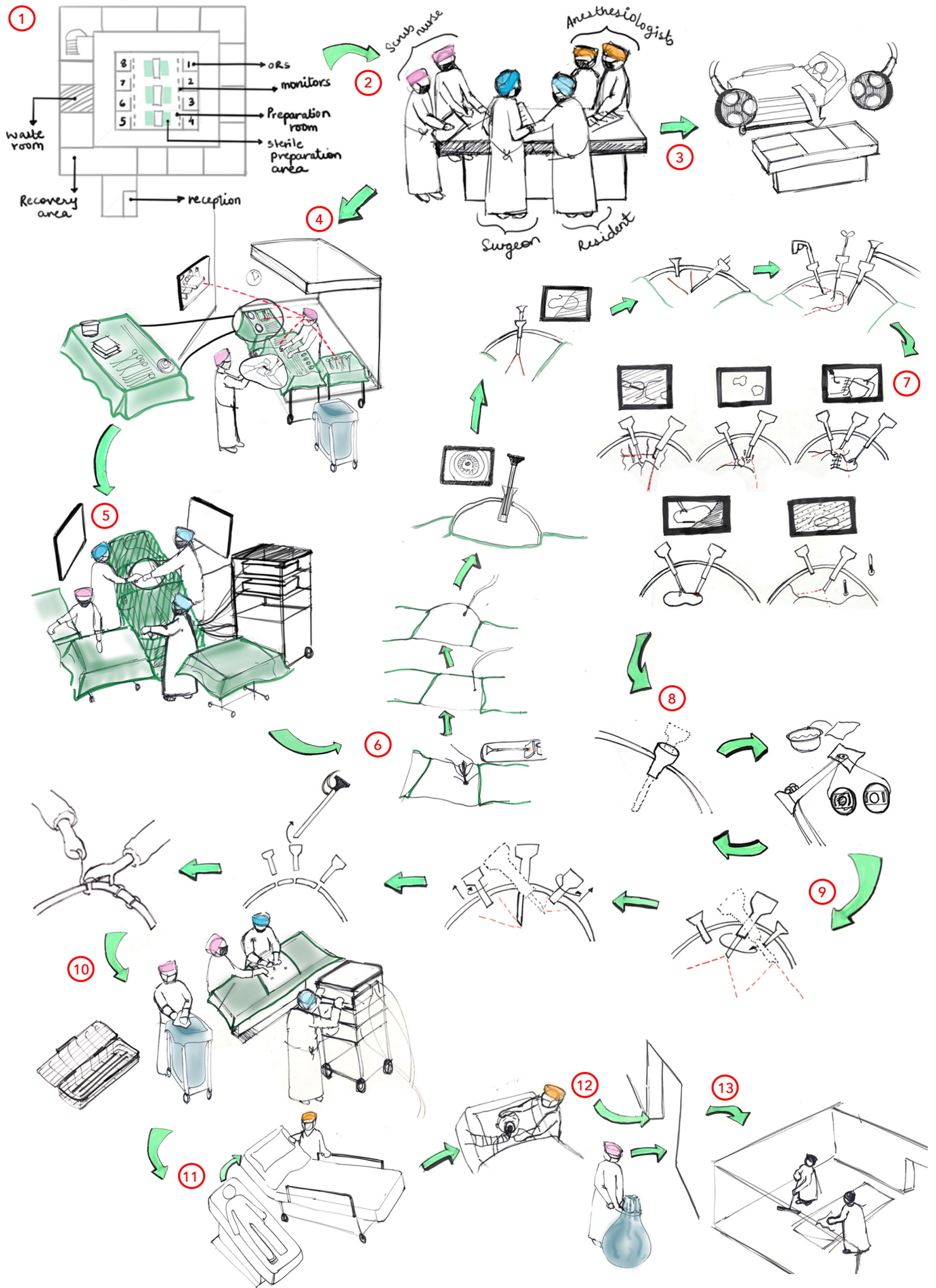

Fig. 16 Work-flow of OR

6) The surgery is begun. The surgeon leads the operation, resident follows it and also takes the lead sometimes to learn. A primary incision is made in the abdomen. Through this, the veress needle is inserted, the insufflator is set to the required pressure and the abdomen is insufflated. During this time the scrub nurse cleans the laparoscope with gauze and solution and keeps it ready. Then the primary trocar (camera port) along with the laparoscope is inserted through this incision. With the help of the laparoscope vision, they can see if the incision has been made right and the trocar is going in the right place. They inspect the operating field. Hence the laparoscope is the first to enter the abdominal cavity. Since the cavity is warmer than outside and also humid, fog forms on the tip of the laparoscope. Other incisions are made at decided locations. Under the laparoscopic vision, they insert the other trocars in through the incisions made (instrument ports) to see if they are inserted right. After this, all instruments are in their respective ports and the determined procedure can start.

7) During surgery, various procedures are carried out. Some procedures are quick while some take a longer time. Each procedure leads to different kind of contamination on the laparoscope lens tip. Depending on the procedure being carried out, contamination happens at different times in the surgery. Dissecting, diathermy, coagulation, etc. generates smoke. This may result in a hazy view. Procedures like rinsing and suction may result in liquid splashes on the screen. During manipulation of tissues and organs, smudges can happen on the lens tip and during the initial inspection fog can build up on the lens tip. During suturing, mostly the view is clear.

8) When the contamination occurs on the lens tip during any of the procedure, the laparoscope is removed from the patient body and manually wiped with a gauze piece dipped in defogging solution. And then reinserted in the patient.

9) Once the procedure is done, they inspect the whole operating sight. They then loosen and unscrew the instrument trocars under the sight of the laparoscope. The trocars and the scope are then removed. Final suturing is done where the incisions are closed.

10) The sterile nurse helps the surgeon or resident with the final suturing. The rest of the nurses and staff present start wrapping up the operating room. They start collecting all the disposables in the large garbage bag. The instruments meant for reprocessing are collected in their metallic cases and are scanned. The connections of medical devices are wrapped up.

11) The other nurses arrive with the patient bed. The patient is transferred, covered up and set properly back to the normal position. The nurses in the meantime call for the room cleaners and take the special waste out of the OR to the waste room.

12) The anesthesiologists make the patient awake and stable to be brought to the recovery room.

13) Finally, the cleaning staff arrives to clean the operating room and make it ready for the next operation. The solution being developed in this project will have to adapt to this flow.

## 3.2 Factors leading to lens tip contamination

To understand which factors lead to the event of contamination and what happened before and after the contamination, the timeline of each surgery was sketched out using the time log. The timelines of all the three surgeries were then compared. These time lines can be found in appendix F. From the timelines and the observations of surgeries two categories of factors which lead to contamination were identified - procedural, (factors arising because of surgical procedures) and contextual (factors resulting from interaction and co-ordination).

### Procedural factors

From the timelines, insights about the procedural factors were gathered. The figure 17 summarizes which procedure results to what kind of contaminant and how is it handled.

Type of procedure	Resultant contamination	Ways of handling it
Inspection	<ul style="list-style-type: none"> <li>- Fog</li> <li>- Smudge</li> </ul>	<p>They try to avoid until the visible area is clear. They don't mind if the periphery is hazy, as the fog goes away. They remove the scope and clean it.</p> <p>The scope is definitely removed and cleaned.</p>
Dissection and coagulation	<ul style="list-style-type: none"> <li>- Smoke</li> <li>- Fog</li> <li>- Fatty / Liquid Splashes</li> </ul>	<p>Unless and until the visible area is clear they continue the surgery as the smoke goes away in a bit.</p> <p>The scope is definitely removed and cleaned.</p>
Rinsing	Liquid Splashes	If the rinsing is in the end, they don't mind the splashes as the view is then not so important. But if it's in the middle of the surgery, then it is definitely cleaned.
Suction	Liquid Splashes	If the rinsing is in the end, they don't mind the splashes as the view is then not so important. But if it's in the middle of the surgery, then it is definitely cleaned.
Suturing	No contamination	Before suturing the view is always cleaned to make sure everything is clearly visible as it a very critical process.
Manipulation	Smudges	The scope is definitely removed and cleaned

Fig. 17 Summary of contaminants resulting from each procedure and their handling methods.

The laparoscope tip was cleaned only when the central area of the screen was dirty. If their area of interest, which is the center of the screen is visibly clean, they continue with the operation. The decision of cleaning the camera is often done on demand from the person who is in lead - the surgeon. Sometimes due to the situation, they prefer continuing even with a compromised view.

They include the cleaning moments strategically like during instrument change or the start of a new procedure or during a break. The current time for cleaning the scope manually is approximately 1 minute.

Surgeons performing robotic laparoscopic procedures using the Da Vinci system, are themselves in control of all the instruments and the laparoscope. Hence they can anticipate the occurrence of contamination better and manage well. However sometimes unexpected splashes of liquid and fat result in contamination.

In robotic surgery, the laparoscope tip has two lenses in order to provide a 3D view to the surgeon while rest of the staff can see a 2D view (view only from one lens) in the screens present in the OR. Hence when there is contamination on the other lens, the staff is unaware of it and the surgeon has to say to clean it. The surgeon sitting on the robotic console, asks for cleaning and the nurse present close to the patient and the robot, removes the scope and cleans using the same conventional method of gauze and defogging solution like other surgeries and reinserts the scope back in the robotic arm

## Contextual factors

Context related factors also accidentally lead to a dirty lens tip. These factors are important to note while designing the future solution as they can happen any moment. Some of the observed contextual factors were changing of the position of the surgeons and residents depending on the situation (figure 18A), crossing of hands of the surgeons or resident while operating leading to an uncomfortable situation (figure 18B), not anticipating the surgeon's move by the camera holder at that moment (figure 18C). These factors may result in sudden and accidental contamination at the lens tip. Another factor is the distance of the lens tip from the target (figure 18D). Closer the tip to the target, more chances of contamination and vice versa. However, some procedures do require a close-up view for better accuracy and hence the contamination is unavoidable. Sometimes the nurses don't clean it properly in one go, and they have to be told multiple times to wipe it properly by the surgeon or the resident (figure 18 E). This can result in some contamination still being there on the tip.

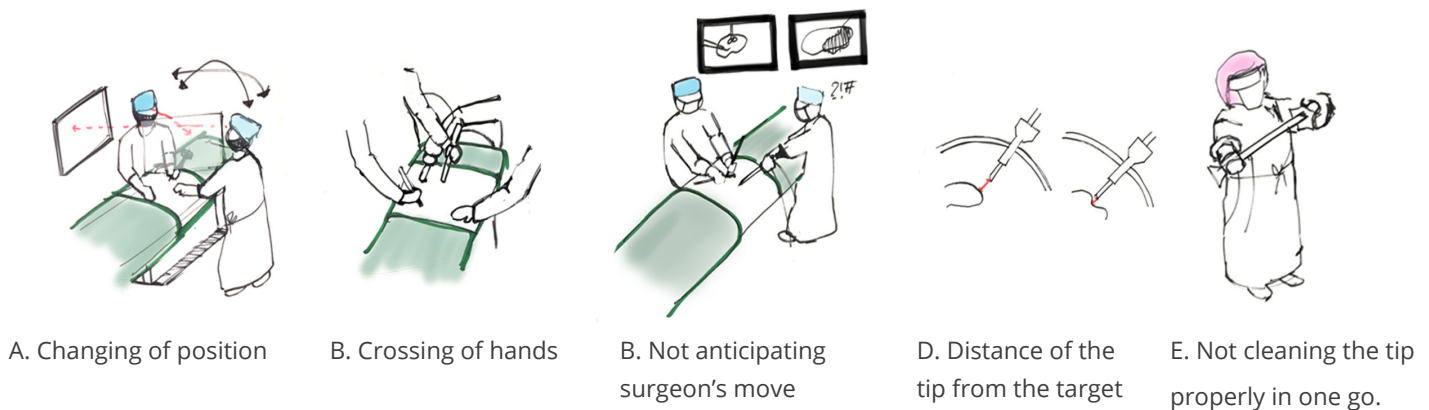

Fig. 18 Contextual factors leading to lens tip contamination.

From the observations, several conclusions can be drawn. Firstly, from the procedure, it has to be noted that only one scrub nurse touches and prepares all the instruments to maintain sterility, the other scrub nurse just assists the sterile nurse minimally where required. So the solution should be able to set up by one person (sterile scrub nurse) and not requiring extra hands. At any point of time in the surgery, the laparoscope is held by one person only and by one hand, hence the solution should be able to operate by one hand. Targeting just the stubborn contaminants (smudges from fats and tissues and liquid splashes of blood and/or water), would already be a major relief to the surgical team because these stubborn contaminants are the ones which definitely lead to a cleaning cycle. The contextual factors which may result in contamination are not in control of the solution. They could be solved with other ways such as improving coordination amongst the team and better training of the personnel.

# 04



## Designing for the OR

In order to design for the operating room, it is essential to study the existing scenario related to the laparoscope. This chapter discusses the ergonomic factors, the ecosystem of the laparoscope and handling styles of the laparoscope by the surgeon.

4.1 Laparoscope holding styles

4.2 Ergonomics

4.3 Ecosystem of the laparoscope



## 4.1 Laparoscope holding styles

To understand how a new device can fit in the current scenario its is necessary to how the surgical team interact with the laparoscope. For this, images showing laparoscopic surgeries in progress were analyzed. An image search on Google was conducted with the keywords “laparoscopic surgeries”; “laparoscopy”; “laparoscope holding styles” to get images of the surgery being conducted. Since acquiring images of actual surgeries from the UMCU was not possible, these images from the internet were considered as the reference. The gathered images were set into a collage and were later analyzed. Some of the images are shown in figure 19. Through this method a certain criteria can be studied across multiple scenarios. In this project, the interaction between the surgeon and the laparoscope were determined. Specifically, how the laparoscope is held in the situation in the image was studied and keywords were noted for each image. These collages and the keywords can be found in appendix G.



Fig. 19 Laparoscopy in progress (images from collages)

When evaluating the images, it was found that the surgeons have different ways to hold the scope. This is also because the laparoscope and the camera system together do not portray a particular holding style to the user unlike in the other instruments with handles. In many cases, the grips were not standard grips. The holding method was highly influenced by the need of the moment in the surgery as shown in the picture. In most of the cases, the scope was held from the camera module. That is the only place accessible and operable by one hand of the person holding the scope. Sometimes the surgeons tilt the scope and operate the scope. Therefore the light cable should not be blocked in any way. In some cases the way they hold their scope is determined by the neighbouring instruments. Hence it's important to consider the scope in its ecosystem throughout the development process. The immediate ecosystem of the laparoscope is already quite crowded, thus the device has to be as compact and not create further clutter.

## 4.2 Ergonomics

The underlying general principle for better work performance is to maintain a neutral posture (Middlesworth Mark, n.d.) (figure 20). This ensures muscles and joints are relaxed and can efficiently contribute to the activity being performed without causing distress. Other fundamental principles are reducing excessive force and movements and working in the comfort zone. However, in the context of laparoscopy working conditions are quite complex. Thus, physical and sensorial ergonomics are often compromised (Supe, Kulkarni, & Supe, 2010). The developed collages of holding styles were analyzed for neutral postures (figure 21). The complete ergonomic analysis of the collages can be found in appendix H. It was found that most of the postures of the person holding the camera were awkward postures. This in dictates that in order to suffice the need of the moment and get the desired view, they adopt to non ergonomic postures unconsciously. The surgeons are too focused on the tasks they are performing that the posture often goes unnoticed.

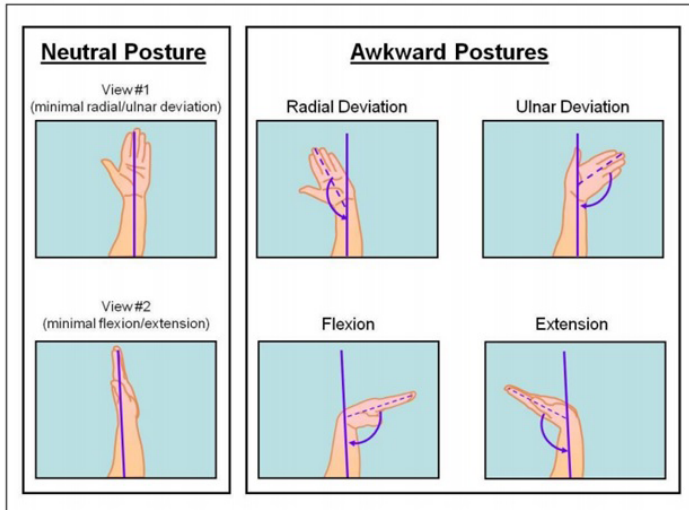

Fig. 20 Neutral and awkward (Middlesworth Mark, n.d.)

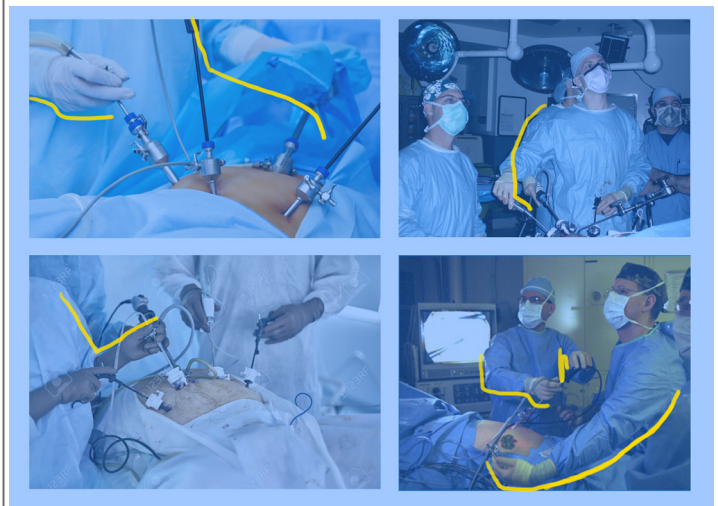

Fig. 21 Ergonomic analysis

## 4.3 Ecosystem of the laparoscope

After gaining an understanding of the ergonomic factors, the immediate ecosystem of the laparoscope was studied. It was essential to consider the laparoscope in its ecosystem rather than in isolation. Its immediate ecosystem consist of the camera system, trocars, the light cable, insufflation tube, other instruments and trocars. Considering the ecosystem of the laparoscope brings to light further constraints for realizing the new solution. For this, a setup of the components involved was created, to have the complete scenario always in mind throughout the development process. As acquiring a real camera system was difficult, a mock-up was created (figure 22). A trocar was obtained from the hospital and the system was set up (figure 23). The holding styles from the collage developed before were acted out with this system .



Fig. 22 The mock-up of the camera system.



Fig. 23 Setup



By acting out and getting the actual feel of the space and components, several insights were gained. Firstly, it was learned that current ecosystem is already very crowded. Secondly, there are no standard dimensions on the scope which be relied on to base the design of the new device. Scopes from different companies have different design. Scopes from the same company also have variations. Apart from the design, scopes are available in different diameters and angles depending on the need of the surgery. The light cable is not necessarily present on all scopes . The camera attached to the scopes are of different configurations and geometries. And also from different companies. Therefore there is not a single physical aspect which can be relied to develop a solution.

There are no standard ways to hold the laparoscope during surgery. The control of the new device which will be on the scope has to be near or around the camera modules as that area is accessible. Often the scope is held in an awkward posture which does not comply with the ergonomic principles. But it gets the job done and the surgeon's focus on the task is maintained. The ecosystem of the laparoscope is very cluttered and crowded and no reliable dimension or part is available to construct the design on. Thus, in order to create a universal and easy to use solution, it is essential that the design of the device is independent of these dimensions, geometries and holding styles but takes into consideration the ecosystem of the laparoscope.

Considering the conclusions of these activities, designing of such advice for the OR seems challenging. There is the need for a reference to base the design on. Matern & Waller, 1999 propose fourteen principles for handle design to develop a functional, comfortable and ergonomic handle for laparoscopic instruments. They are stated below:

1. The handle should allow several functions to be performed.
2. The handle must be adjustable for various hand sizes.
3. The handle should be as small as possible.
4. The handle should allow one-handed use.
5. The function should be ascertainable from the handle's design.
6. Functional elements must be designed to prevent pressure areas and possibilities for injury.
7. Functional elements should be operated by the sensitive areas of the hand.
8. Functional elements must be easily accessible.
9. Size and dimensions of the functional elements should allow easy manipulation.
10. Any necessary springs must function adequately and should in no way hinder use.
11. Indirect power transmission with loss of power is to be avoided.
12. The instrument should have minimal autonomous dynamics (artificial movements).
13. Cramped positions, as well as excessive shoulder movements, are to be avoided.
14. The instrument's shaft must be an extension of the forearm's rotation axis."

These principles could act as a checklist while developing the new solution.

# 05



## Understanding the market

This chapter elaborates on studies about the existing solutions in the market, the positive and negative aspects, their adaptability to the current context, the technologies currently used for this problem and the choice of technology which will be focused in this project. Each of these studies concludes by providing requirements for the future solution being developed in this project.

Frugal, simple attempt.	Less resources, easy actions, wise use of material to influence design.	Friction with existing system.	Only available for one kind of MIS, not universal.	Need for change in current condition, complex connections.	To many peripherals to make design universal.	Negatives to avoid.
Need of a specific component to make the whole system work.	16 Different options for different staff creating confusion, requiring.	Too many resources being waste after a rather small use of resources.	Software defectancy.	Just focused on this solutions. Big companies follow standardization and shows recent, comp-focused on this, just have a approach of problem however, simple of frugal solution.	Many endoscope/companies available. Therefore, the connections between companies vary. After so that they have monopoly and hospitals are compelled to buy the set or they don't buy mismatching items and deal with it.	Concentration of companies working on this problem is in US.
Some solutions with more components are easy to setup while also requires lot of effort.	Balance of effort according to the function.	Providing a solution for scopes from all companies, for all angles, all diameters, is very difficult. No company has attempted with their current approach.	All solutions are somewhat with force on removal etc. of wiping.			





- 5.1 Analyzing existing solutions
- 5.2 Making technology choice

## 5.1 Analyzing existing solutions

In order to understand the evolving trends and the technology surrounding the problem of laparoscope lens tip contamination, it is essential to analyze the existing solutions in the market at the moment which cater to this problem. By knowing their drawbacks and the positive aspects, informed design decisions can be made for the new solution. This will then be able to fit in the context learned in the previous chapters.

For this analysis, a web search using the Google search engine was done. The companies which had commercially available solutions for the problem of lens tip contamination were retrieved. They were shortlisted for analysis based on certain factors such as if the company is still active in the market, if the product is available in the market, the relevancy of the product to the problem of laparoscope lens contamination.

The shortlisted solutions were studied separately and its information was documented. This documentation can be found in Appendix I. To analyze these solutions the feature matrix method was used. In this method, various features of the products are listed on the vertical axis and the products to be compared are placed on the horizontal axis. Features of each of the solution are placed in the appropriate box. This provides a complete overview of the existing solutions. Figure 24 shows this matrix. From this feature matrix table, upcoming trends and few insights can be spotted. They are explained further.

COMPANIES	Cipher Surgical	Minimally Invasive Devices Inc.	Olympus	Medtronic
YEAR	2010	2007	1919	1949
LOCATION	England	US	Tokyo	US
PRODUCT NAME	OpClear	FloShield	InstaClear	EndoScrub
IMAGE				
IN SITU/ NOT IN SITU	IN	IN	IN	IN
METHOD OF CLEANING	Fluid inflow irrigation	Fluid inflow irrigation	Suction irrigation	Irrigation
NEED FOR POWER SUPPLY	YES	NO	YES	YES
REPROCESSABLE OR DISPOSABLE	Sheath - D Rest - R	D	Sheath and tube set - D Rest - R	-----
COST	-----	50 \$		29 \$ per sheath
COMPATIBLE SIZES	0, 30 degrees 10mm dia	0, 30,45 degrees 5mm & 10mm dia	0,30,45,70 degrees 4mm X 150,180 mm dia	-----
COMPATIBLE SCOPE COMPANIES	Most of the rigid laparoscopes	Storz, Olympus, Stryker and Wolf	Storz and Olympus	Compatible with its own console and scopes by many companies
TYPE OF SURGERY	Laparoscopy	Laparoscopy	ENT surgeries	ENT surgeries
DIFFICULTY IN SETUP	●●●●○	●●●○○	●●●○○	●●○○○
NUMBER OF COMPONENTS	~6	~4-5	~6	~3
POSITIVE TAKE AWAYS	Foot switch triggered, hands free approach.	No power requirement and structural manipulation to achieve and action. (channels of varying size to create a vortex of air at the lens tip)	Adaptability with their own existing system, creating a whole package deal.	
NEGATIVE PITFALLS TO AVOID	To many peripherals to take care of in order to make the design adaptable to more scope sizes.	Changing the current scenario to accommodate the design. (need for trocar valve)	Only available for one kind of surgery, when the problem is persistent in other type of surgeries as well.	Dependant on a specific system/software.





Medtronic	Clear Cam Inc.	Conmed	Karl Storz	Ethicon	Virtual Ports
1949	2018	1970	1975	1992	2006
US	US	US	Europe	US	Israel
Clearify	Clearcam	LaproVue	ClearVision II	Endopath Xcel Trocar	EndoClear
					
OUT	IN	OUT	IN	IN / OUT	IN
Defogging and warming	Wiping	Defogging and warming	Suction irrigation	Wipe, wick and absorb	Wiping
YES, battery	NO	YES, battery	YES	NO	NO
D	D	D	R	-----	D
35 \$ per piece	-----	-----	4499.99 \$	-----	-----
all angles 5 - 12mm dia		Many scope dimensions	many angles 2.7mm - 4mm dia	many angles 5,8,11,12 mm dia	NA
All scopes	In development	Many scope companies can be accommodated	Compatible with Hopkins telescope only.	Scopes falling in the above mentioned dimensions.	NA
Laparoscopy	Laparoscopy	Laparoscopy	Laparoscopy	Laparoscopy	Laparoscopy
● ◐ ○ ○ ○ ○	● ○ ○ ○ ○ ○	● ◐ ○ ○ ○ ○	● ● ● ○ ○ ○	● ○ ○ ○ ○ ○	● ● ● ● ○ ○
~3	~1	~4	~4	~1	~1
	Frugal and simple attempt at a complex problem. Wise material choice, minimum actions, using material properties to achieve the output.		Use of negative pressure to remove residue out.	Using capillary action to advantage.	Using Current intuitive movements to develop a product around it.
Not wise use of resources. Too much for a single use device.	Might cause abrasion to the lens or hinder the view.	More options and details might create confusion.	Need for a specific small component, to make the whole system work.	Only solving a part of the problem.	Achoring in human body, damage caused and setup time.

Fig. 24 Analysis of existing solutions

## Feature matrix analysis

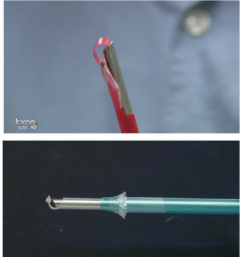
### Compatibility

There are many leading companies in scope manufacturing. Due to which cross-company product compatibility is crucial. The hospital has some equipment from Storz, some from Olympus, some from Wolf, depending on the deal, quality, need, etc. So a new solution has to comply to at least leading scope providers to be adopted easily. Often big companies make new devices dependant on their existing devices, like parent console or scope as it is easier and quicker to launch a new device that way. Also with this approach, they can have a monopoly and hospitals are then compelled to buy it as a package.

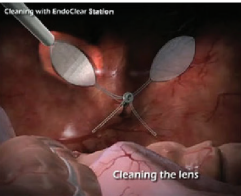
### Minimum parts

Some solutions have more components and consumables, while some are single component based. Interestingly, even with one component (EndoClear), some solutions are difficult to setup while some with more components are easier to assemble. Hence, a solution with minimum parts and thus minimum efforts to set up should be ideal.

### Use of fundamental techniques

Using more fundamental techniques like negative pressure, structural manipulation, taking advantage of material properties, helps to achieve the desired results rather than relying on standard mechanical methods.

### Awareness

From the interviews, it was found that most of the stakeholders were not aware of many of these existing solutions. They were mostly aware of defogging solutions as they used that. This has to also do with the surgeon's perception of the problem. As learned in chapter 2.2 , they perceive it as a small problem which is often forgotten in the complexity of the operation. So they don't feel the need to search for a specific solution for this issue and hence they are not aware of the solutions at their disposal.

### Frugal Approach

The trend which emerges across the solutions is that the newer companies have a frugal and simple approach. They propose solutions which do not require power. This shows it is possible to venture in such a direction. This might increase the chances for the solution to be adopted easily. Older companies, still provide bulky solutions which are primarily power based.

## Analysis of the products with identified stakeholder needs

The selected solutions were also analyzed with the stakeholder needs identified in chapter 2 to see which of these solutions were close to the context requirements and why couldn't they function in this complex context. This helped to understand, what needs to be taken care of while designing the new solution. The shortlisted products were evaluated on the following parameters:

- Small
- Less complicated setup
- Efficient
- Minimum interaction during surgery
- Quick
- Easy disassembly

The overview of this analysis can be found in appendix H. From the analysis it is evident that none of the solutions could tick all the boxes. This could perhaps be the reason for them not being extensively used or adopted. A solution which would comply with all (or at least majority) of the findings could definitely work in the complex context of laparoscope use. The products which were close enough were InstaClear by Olympus and ClearCam. They complied with most of the requirements. However, the efficiency of the solution, which is a crucial parameter, cannot be yet guaranteed in the ClearCam, as it's in development. During a discussion with Arien Broere a medical engineer, and Stefan Been a Medisch Technologie Adviseur at Medische Technologie & Klinische Fysica (MTKF), UMC Utrecht, it was found later that they do use InstaClear in UMC Utrecht. Summary of discussions with them can be found in appendix J. However, it is used only for ENT surgeons. UMC changed its supplier to Olympus from Karl Storz, because they offered a full package of service and infrastructure along with the devices and are more like a partner than a supplier, also they mentioned, that Olympus provided superior quality of devices. These could be a few of the reasons for the adoption of InstaClear. The device, however, can still be considered complicated as it involves tubes and cables to be connected and taken care of during the surgery. To understand what aspect of the Instaclear were positive, an interview with a KNO surgeon was conducted. The pattern of the interview was kept the same as mentioned in chapter 2.1. The transcript of the interview and the interpretation can be found in appendix K. From the discussion, it was understood that the Instaclear really helps in sinus surgeries which were the most surgeries performed in UMC Utrecht. Since KNO surgeries do not involve insufflation or use of trocars using Instaclear becomes relatively easy. The aspect of the product which was most appreciated was the actuation of the cleaning method on demand via foot pedal and the quick cleaning action. However, it was noted that the setting up of this device was still cumbersome with all the tubes and cables and also it didn't give the choice of controlling the suction or rinsing movement. But due to the high need of cleaning the tip in KNO surgeries, this device is still preferred. And since all the other devices in KNO surgeries are from Olympus, they would definitely prefer Instaclear due to compatibility.

There is not yet a product which meets all the contextual requirements while being efficient. Instaclear has been the close to the requirements, but there are various factors which contribute to its use. Compatibility to major scope suppliers and having as minimum parts are the key for the solution to be adapted easily. Along with these, following the upcoming trend of frugal power less approach will add to the product desirability.

## 5.2 Making technology choice

Several cleaning technologies and methods exist for the problem of laparoscope lens cleaning. In order to deep dive into a certain method in the time provided for this project, it was decided to make a choice of the technology direction early on in the project. The study by Kreeft et al., (2017) compared different techniques to achieve optical surface cleanliness and their possible applications to surgical endoscopes. At this point in time, their research is the latest in this field and gives a complete overview of the solutions, patents, and literature surrounding this solution space. Hence this paper was chosen to be the guidance for technology selection. From their research it can be concluded that the current solution space for this problem is concentrated with correction methods meaning, focusing on cleaning the lens tip after it gets dirty, rather than preventing the debris to settle on the lens in the first place. This would be a preventive approach. Preventive methods could be a new perspective to look at this problem. Their research also shows technical potential in preventive techniques to maintain the cleanliness of optical surfaces. These techniques talk about a barrier between the lens tip and the incoming debris. Two potential preventive methods from the study were considered and researched further. They are described below.

### Movable surface method

This method involves a movable surface in the form of film or strip over the distal window of the laparoscope. The surface allows the impurity to settle on it instead of the surface beneath it. Once the surface is contaminated, it can be moved quickly to dispense a clean surface again over the tip. This method is also used in mud goggles used by race bikers (figure 25). In their case also the view is quite critical when they are biking. In such times when their view becomes dusty or muddy due to the surrounding terrain, they dispense a new transparent plastic surface over their goggle with a click of a button. This takes the old surface with the collected muddy impurity away from their sight and provides a clean vision.



Fig. 25 Mud goggles used by motor cyclists ("100% Accuri Forecast Mud Goggles | Fluo Yellow Clear Lens | DirtbikexpressTM," n.d.)



Attempt 1

Two attempts can be found in the literature showing the exploration of this method. One is a conference paper (Anderson, Zimmerman, Houston, Farino, & Begg, 2010) describing the design of a shielding device to clean the laparoscope tip involving a movable film. No future advancement on the work can be found on the conference paper after 2010 (Figure 26)



a. Endoscope and shielding device before assembly



b. Endoscope and shielding device upon assembly

Fig. 26 The device design presented in the conference paper (Anderson et al., 2010)

Attempt 2

Another is a patent (John P. Newton, 2012) describing a transparent movable film over the tip of the endoscope (figure 27). The patent has not been granted yet. Both of them talk about a dispensing system, which dispenses such a film over the tip of the laparoscope. This system has a manual trigger. An action by the user brings the fresh surface in front of the lens in the event of contamination. This method in principle is a simple mechanically driven approach. The work of Anderson et al., (2010) shows the efficacy of this solution and how to further optimization could help make it more usable and adaptable in the hospital setting.

US 2012/0178995A1

(19) **United States**  
 (12) **Patent Application Publication** (10) **Pub. No.:** US 2012/0178995 A1  
 (43) **Pub. Date:** Jul. 12, 2012

(54) **METHOD AND APPARATUS FOR CLEANING THE FIELD OF VIEW OF AN ENDOSCOPIC LENS**

(75) **Inventor:** John P. Newton, IV, Pittsburgh, PA (US)

(73) **Assignee:** Parametric Mechanisms, LLC, Pittsburgh, PA (US)

(21) **Appl. No.:** 13/044,242

(22) **Filed:** Jan. 5, 2012

**Publication Classification**

(51) **Int. Cl.** A61B 1/00 (2006.01)

(52) **U.S. Cl.** 600/121

(57) **ABSTRACT**

An endoscope lens protection apparatus may include a clear indexable film strip positioned over the endoscope lens having an underside surface and an opposite exposed surface, such that the underside surface is positioned to face the endoscope lens, and the incision side surface is exposed, wherein the indexable film is movable from a clean film position to a used film position, such that, in operation, the indexable film is advanced from a point in front of the lens to a used film position out of the endoscope field of view, and may further include a sheath having a proximal end and a distal end defining a chamber therebetween configured to receive the endoscope body; an interior sheath surface defining a film supply channel and a film retraction channel. A sealing mechanism associated with the sheath may also be included.

**Related U.S. Application Data**

(60) Provisional application No. 61/429,876, filed on Jan. 5, 2011, provisional application No. 61/448,737, filed on Mar. 3, 2011.

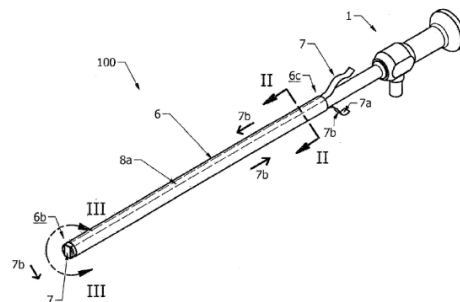

Fig. 27 Patent describing the movable film concept (John P. Newton, 2012).

## Hydrophobic or adhesion resistance method

This method involves having a surface which does not let the liquid adhere to it. The adherence of the liquid is decided by the water contact angle. The water contact angle (WCA) is the angle at which the liquid-vapor interface meets the solid-liquid interface (figure 28). The greater this angle more is the tendency of the surface to repel liquids, hence the surface is called hydrophobic.

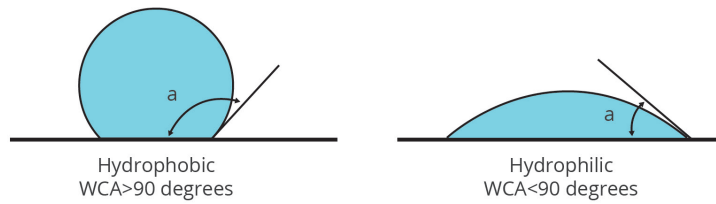

Fig. 28 Water contact angles determining the nature of the surface.

### Attempt 1

Two recent papers were found on this subject.

The first paper was by Sunny et al., (2016). They describe the use of these surfaces in the field of endoscopy to shield the lens from biofouling and improving visibility. Their research and tests, look quite promising. They explore liquid infused surfaces for achieving a superhydrophobic surface (figure 29). They created such a liquid infused surface on the glass cover at the tip of the endoscope using it as its substrate. This surface was created with layer by layer deposition of silica particles. This surface was also able to achieve, transparency, which is the most important factor for the endoscope. The focus of this paper was to prove the use of liquid infused surfaces to maintain a clear view during endoscopic procedures. There was not much stress given on the fabrication of such materials on a commercial scale.

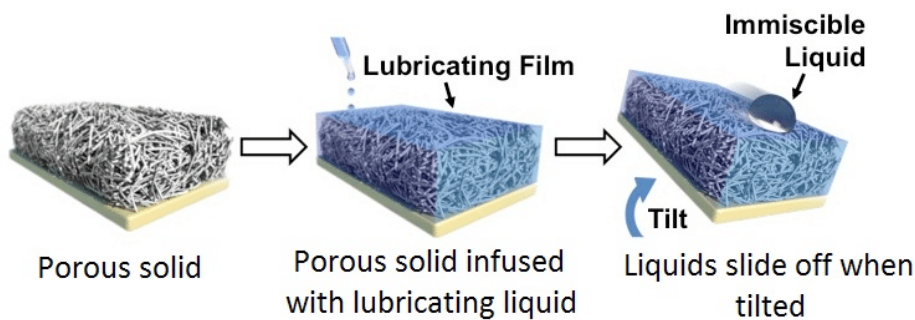

Fig. 29 Principle of liquid infused surfaces (Hemed, 2017)

### Attempt 2

The second paper was by Park, Park, and Lee, (2018). Their paper focuses on the fabrication of optically transparent, superhydrophobic thin films. They propose a way to fabricate such surfaces using a mold which can be reusable. Principally they explore and mimic the nanostructured surface of the lotus leaf (figure 30). They developed this surface using polydimethylsiloxane (PDMS) as it has high optical transparency. This suggests that this could also be applicable to the endoscope to achieve optical clarity. The simple fabrication process of this material opens great potential for diverse applications.

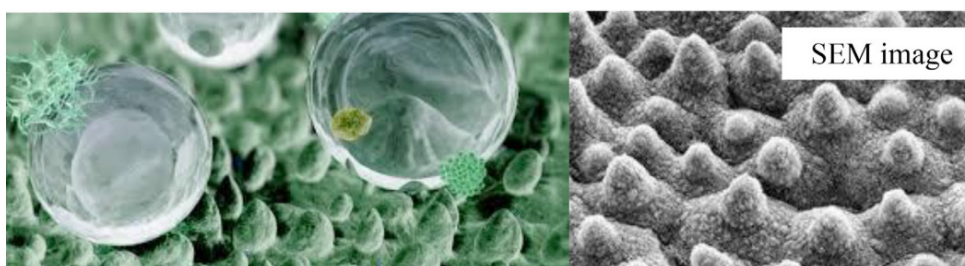

Fig. 30 Natural nanostructure of the lotus leaf (Park et al., 2018)

In order to get more clarity on these two materials and which one could be more relevant for the solution, a discussion was conducted with Assi. Prof. Murali Ghatkesar from the Faculty of 3ME. The details of the discussion can be found in appendix L. From the discussion, it was understood that the second approach of fabricating thin optically transparent films was a more relevant and achievable direction for the problem of laparoscopic lens contamination. He further explained the basic principle of such surfaces, what factors to keep in mind while making such surfaces and facilities available in TU Delft for this purpose.

Both of these methods utilize a surface to shield the lens from debris. Kreeft et al., (2017) further state that though these methods offer prospective solutions, they do have certain limitations which need to be considered while developing a device using them. The possible issues with the movable surface method could be an increase in dimensions, attaching the fresh films and detaching the soiled ones, problems in reprocessing, capillary action making the debris come back, etc. While, with the hydrophobic surfaces, the possible hurdles could be durability, the influence of high temperature, reprocessing, not enough angle of the scope for the liquid to slide off, biocompatibility, etc. These limitations are essential to keep in mind early on while developing a solution. This solution space has not yet been explored to the fullest. In order to dive deeper in the time provided for this project, it is decided to take the preventive approach and focus in the direction of shielding methods.

By keeping the contextual findings in mind, the second method of hydrophobic surfaces seems the most promising direction for developing a solution. This is because the human interaction with the device could be removed completely and a hands-free, simple and efficient solution could be achieved which ticks off many contextual requirements. However, the commercial feasibility of these surfaces is yet not proven. It is a fairly recent technology and hence the thought of, achieving, fabricating, testing such a superhydrophobic material encompasses a whole different research question, which could be out of expertise and scope of the project. But it is indeed an interesting direction to venture and would require a multidisciplinary team. More explorations into current commercially available hydrophobic materials and their capabilities could give some solution possibilities. The movable surface method provides a feasible solution at this point in time. It tackles the stubborn contaminants by changing the surface completely. This eliminates the need for constant wiping and also shields the surface of the laparoscope from the environment. This will also, in turn, increase the life of the scope.

Thus the way ahead could be to have a hybrid approach. By combining the advantages of both the methods, hydrophobic surfaces and the movable surface method, a balanced solution can be created. This technology can then be optimized to the findings of the context.



## Design Vision

Much information was gathered from the research activities. From this information a vision for the future design of the product can be drafted. This chapter summarizes all the insights gathered. From this summary, design requirements of the new solution are drawn. From all the learnings, a concrete assignment for the project is defined. The chapter concludes by defining the overall scope of the project which will be addressed in the time frame of this master project.

6.1 Overview of the insights

6.2 Design requirements

6.3 Assignment and project scope

## 6.1 Overview of the insights

To make all the insights usable and clear, an overview of all the findings was prepared. This overview is described below. The overview makes it easy to assimilate and link the information to form design requirements.



In order to create a holistic and applicable system for both surgeons and hospitals, there is a need for a clinically driven approach rather than only a technological approach

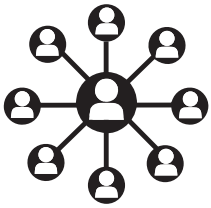

The solution needs to be small, have less complicated setup, be efficient in cleaning, involve minimum interaction during surgery, be quick in cleaning and be easy to disassemble for better processing after the surgery. The solution should be very simple in nature to match its perception in the surgeon's mind. An over complicated and high tech solution might feel an overkill to the surgeon for the purpose it is intended for.



The solution should be able to set up by one person (sterile scrub nurse) and not requiring extra hands. At any point of time in the surgery, the laparoscope is held by one person only and by one hand, hence the solution should be able to operate by one hand. Targeting just the stubborn contaminants (smudges from fats and tissues and liquid splashes of blood and/or water), would already be a major relief to the surgical team because these stubborn contaminants are the ones which definitely lead to a cleaning cycle.

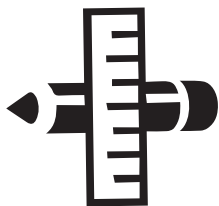

It is essential that the design of the device is independent of these dimensions, geometries and holding styles but takes into consideration the ecosystem of the laparoscope.



Compatibility to major scope suppliers and having as minimum parts are the key for the solution to be adapted easily. Along with these, following the upcoming trend of frugal power less approach will add to the product desirability. Pursue shielding methods as a technology direction that is having a hybrid technological approach of both the methods, hydrophobic surfaces and the movable surface method.

## 6.2 Design requirements

From the summary of all the insights, a comprehensive set of design requirements which the future solution should have was formed. These requirements were divided into two categories – Needs and Wants. The needs are the ones which a solution has to comply by, whereas the wants are those aspects which the solution may or may not comply with. Although it would be ideal if the solution complies with them all. Based on these requirements, concepts can be tested. These requirements are described below:

**NEEDS** | The solution should be -

**Small in Size:** The solution should be able to conform to the existing tolerances between the trocar and the laparoscope of about 1.5mm. At the same time, it should allow the insufflation gas to pass easily and not compromise with the existing degrees of freedom of movement of the scope in the trocar.

**Less complicated:** The solution should not require more than 3 steps to set up for use during the surgery.

**Minimum interaction:** The solution should be operable in not more than one action during the surgery.

**Fewer efforts:** The solution should be able to set up by one person (sterile nurse) hence not requiring extra hands.

**Compatible:** The solution should be primarily compatible with the scope of diameter 10mm and with angles 0, 30, 45, 70 degrees.

**Ergonomic:** The solution should be operable using only one hand by the person who holds the scope during the surgery. The solution should adapt to their current working style.

**Efficient:** The solution should clean the tip of the scope of the stubborn contaminants like smudges and fatty splashes.

**WANTS** | The solution would be ideal if -

**Compatible:** Compatible with diameters of the scope ranging from 3mm-12mm . Compatible with angles 0, 30, 45, 70 degrees

These requirements would further keep evolving during the process of development. A solution which complies with these requirements will very well fit in the complex context of laparoscope's use.

**Quick:** The solution should take the same or less amount of time than used currently to clean, so 1 minute or less. The solution should be able to set up in a maximum of 5 minutes.

**Biocompatible:** The solution should use medical-grade material. The material at the tip should be fully transparent. The material should allow the initial sterilization of the device before use.

**Safe:** The solution should not have any parts which can detach and fall inside the patient. It should not have any sharp or moving parts while it is inside the patient.

**Reprocessible:** The solution should allow for responsible processing after its use.

**Clutter-free:** No cables, should be cable free

**Actuating mode:** Mechanical operation not electronic

**Operating way:** Scope in same position always, not move not rotate, not lose the operating view.

**Self-reliant:** Not dependent on power, special parts or parent consoles.

## 6.3 Project scope

From the learned insights, a concrete assignment for the project was formed. Thus the assignment is as stated below:

“Design an ergonomic shielding solution to ensure a clear vision of the operating field by protecting the laparoscope lens tip against contamination in situ.”

Development of such a solution entails several components and aspects. In order to have a feasible target for the timeframe of this project, it was decided to concentrate on certain aspects of product development. The rest of the aspects would be developed after the project with relevant expertise and resources. The end goal of this project was decided to be a concept design which meets the user and contextual demands and demonstrate its holistic nature. For this Along with this, it was also decided to define the technical requirements of the product. This can be further elaborated during the engineering phase which would be after the project. Figure 31 shows all the aspects concerning the device development and the parts which will be achieved through this project.

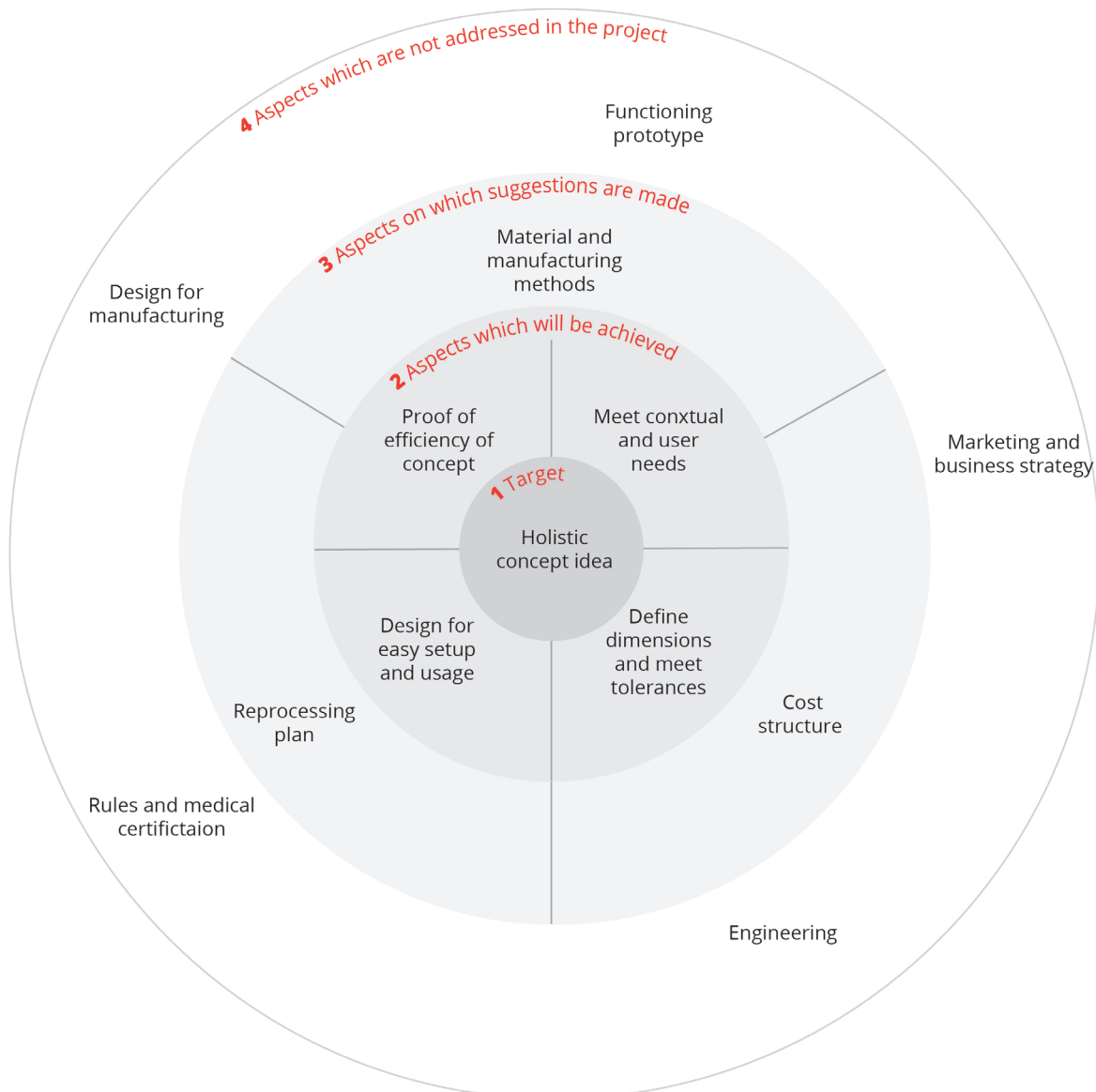

Fig. 31 Defined project scope

# IDEATION & EXPLORATION





# 07



## Ideation

At this point in time, various ideas were generated while conducting the research. In order to have a fresh perspective on the problem area and collect a wide range of ideas, ideation sessions were conducted. Besides obtaining new design directions, the aim of these ideation sessions was also to gain confirmation on previously thought direction of shielding methods, whether it's wise to venture into or not.

7.1 Ideation sessions

7.2 Forming design directions

7.3 Choosing a direction

7.4 Exploring the chosen direction

7.5 Refining the design direction

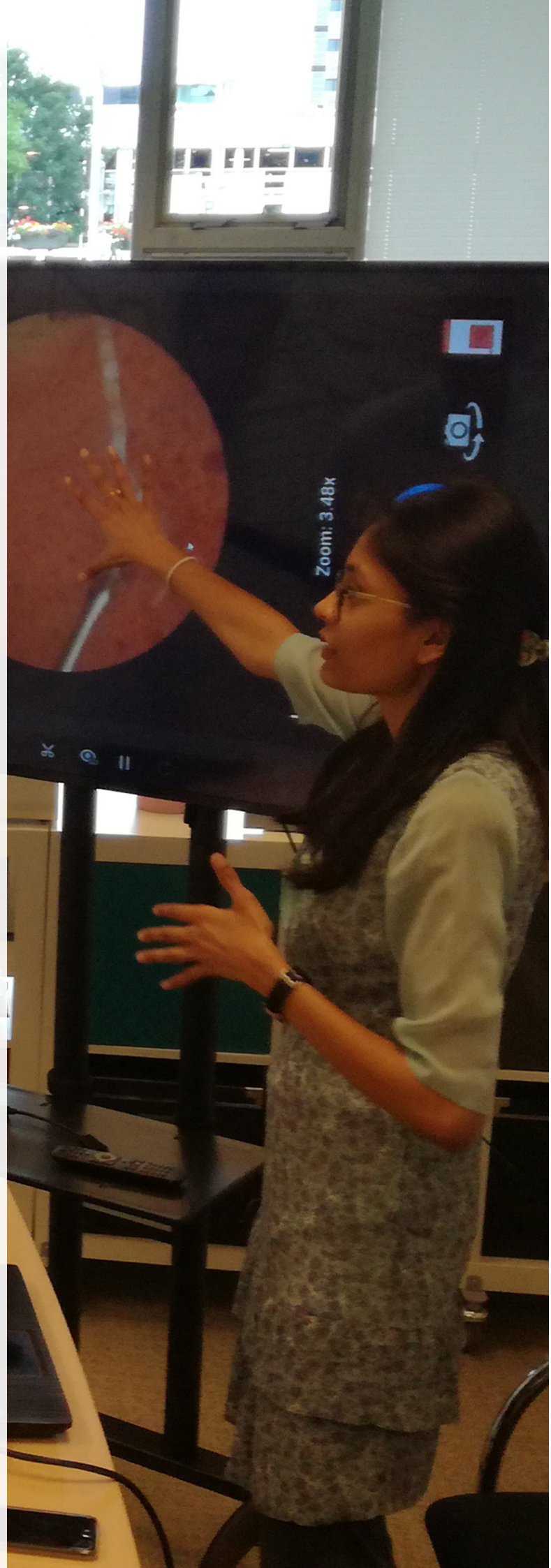

## 7.1 Ideation sessions

Three ideation sessions were carried out in total. Two of these were done with students from the Faculty of Industrial Design Engineering and one was conducted with the members of Pontes Medical. The surgeons and nurses are conditioned in the way they work and are bound by surgical constraints, hence they have a set method of approaching a problem. As students and designers have no previous knowledge about the constraints involved in this subject, unbiased thoughts and ideas can be gathered. Hence this choice of participants.

### Procedure

The sessions were tailor-made according to the participants. Each session was divided into four activities namely Familiarize, Brainstorming, Rolestorming, and Discussions. Each activity was performed for approximately 15 minutes. Below is the brief explanation of each of these activities:

**Familiarize** | The participants in the first two sessions were completely new to the subject of laparoscopy. Hence it was essential to familiarize them with basic terminologies and methods. This would help them to empathize with the topic while brainstorming. For this, a short presentation was given at the beginning (figure 32). The problem area was explained in this presentation. The participants in the third session at Pontes Medical were already aware of the subject and the problem area, hence this part was skipped with them.



Fig. 32 Familiarize

**Brainstorming** | The aim of this activity was to capture the initial unbiased thoughts and ideas of the participants. After the presentation, the participants were asked to sketch and write down the first ideas which come to their mind upon learning the problem area (figure 33). The question asked in this activity was- "How to protect the tip of the laparoscope from liquidy stuff while it is inside the patient?"

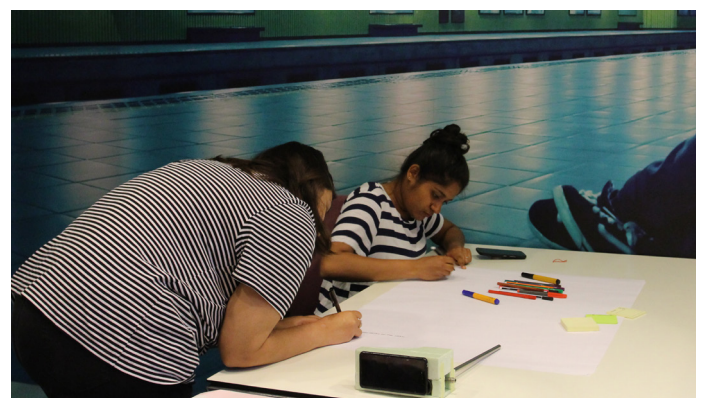

Fig. 33 Brainstorming<sup>59</sup>

Rolestorming | The aim of this activity was to see, how would the participants react in that instant, given the situation. The instantaneous reactions would provide insights for developing intuitive solutions. In this activity, the participants were asked to act out their ideas with the help of a simulated surgical setup (figure 34). The details of the setup can be found in appendix L. A situation involving a task was described to participants and they were given the roles of surgeon and resident. They were asked to act the situation out and also to speak out loud while acting. It was conducted in a pair. The main question asked in this activity was- "How will you clean the tip while operating with one hand?"

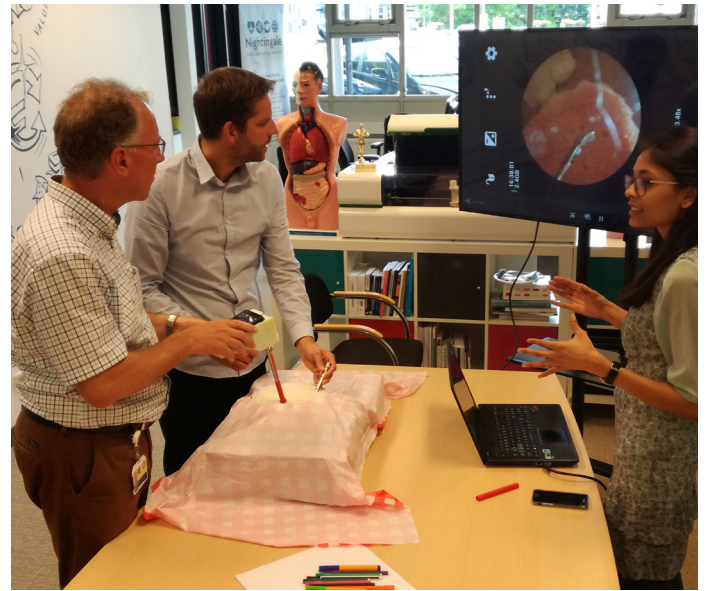

Fig. 34 Rolestorming

Discussions | The aim of this activity was to discuss every participant's ideas and thoughts behind it and build up on their ideas on the spot to come up with different solutions. During this activity, the ideas generated were explained and discussed with everyone and more ideas were sketched out on the spot (figure 35).

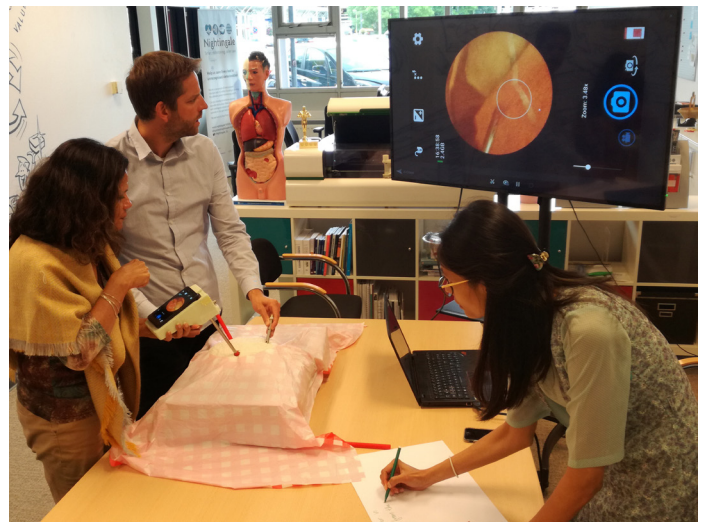

Fig. 35 Discussions

For the first two sessions in the University, the brainstorming activity was done first followed by Rolestorming. Later during the rolestorming activity, the participants engaged themselves with the setup, got into their roles and acted out the situation. They realized a few constraints of the environment and pressure of the situation and gave different kind of ideas from the brainstormed ideas. During this process, they also validated their own previously sketched ideas in the brainstorming activity, for whether it will work or not.

In the third ideation session at Pontes Medical, the rolestorming activity was performed first. This was done because they have been involved in similar brainstorming sessions before for this project. By roleplaying in the beginning they could engage in the problem-solving in a different way and this helped to change their preformed notions with respect to this problem. After roleplaying, the participants were asked to realize their ideas which they came up during roleplaying by sketching and drawing it out. Later on, they were discussed and shared with everyone. The ideas generated during brainstorming and discussions were captured through sketches on chart papers. These sketches can be found in appendix M. While the ideas generated during rolestorming were captured through videos.

## 7.2 Forming design directions

The sketches and the videos were analyzed and the ideas generated ideas were noted down and clustered into groups depending on similarities, methods and functions. These ideas along with ideas generated before during research were then summarized together using a morphological chart (figure 36). The morphological chart helps to categorize range of ideas based on the function they provide. 5 broad sub-functions were recognized from the ideas generated and were placed on the vertical axis and the ideas pertaining to each sub-function were placed on the horizontal axis. From the morphological chart, 6 combinations of set of solutions were made. Every combination yields a different solution direction. Thus 6 possible solution directions were derived. They are marked by coloured circles on the chart (figure 36). Each colour corresponds to a direction.

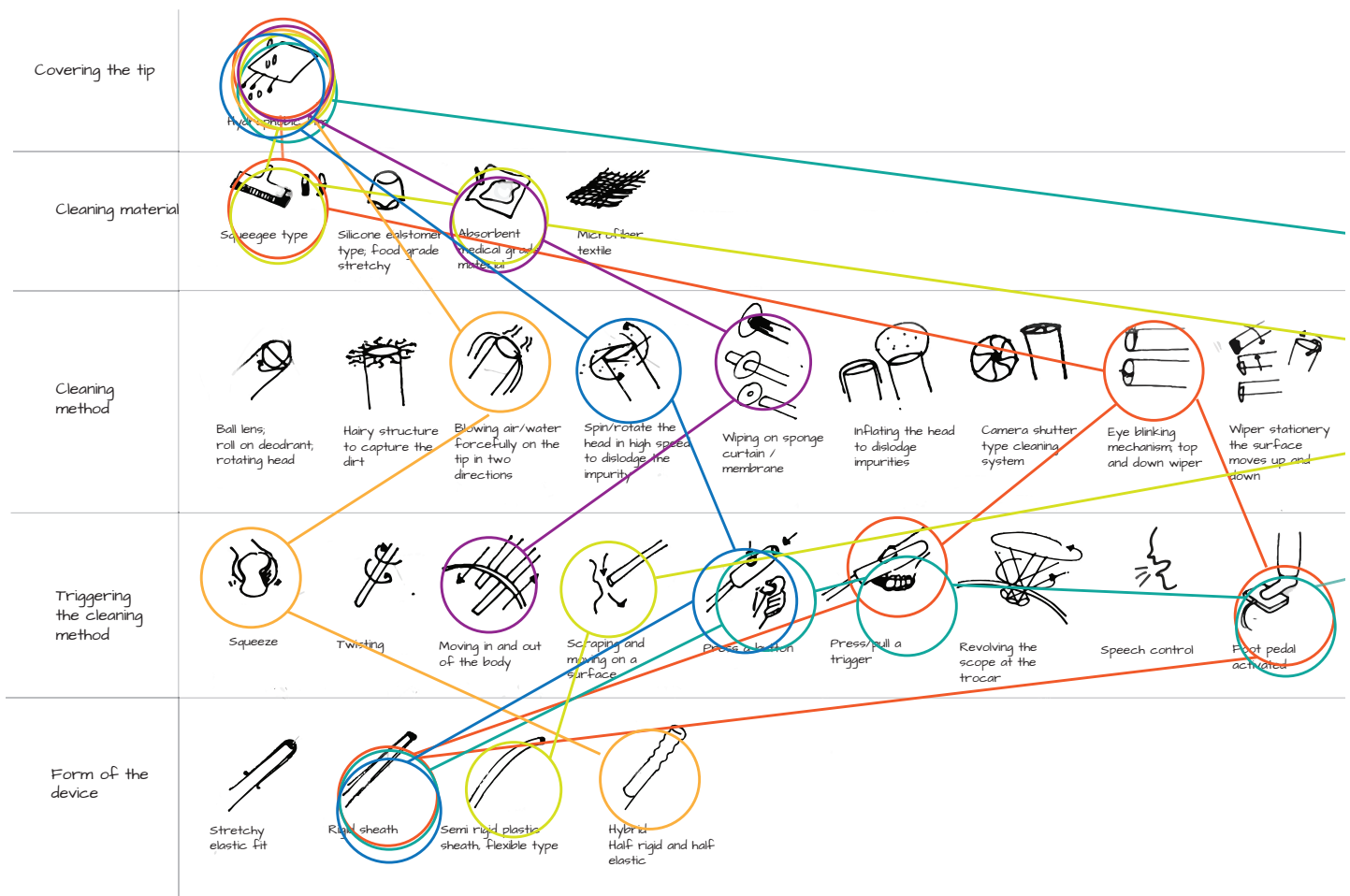
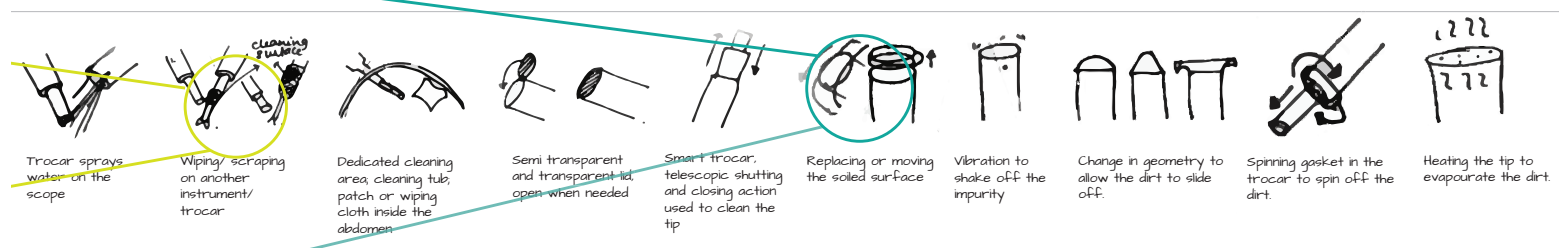

Fig. 36 Morphological chart

- Direction 1 : Hydrophobic cover + Blinking mechanism (like in the eye) + Squeegee/absorbent material + foot pedal/ trigger + rigid form factor
- Direction 2 : Hydrophobic cover + Replaceable /movable surface + button /trigger/foot pedal operation + rigid form factor
- Direction 3 : Hydrophobic tip cover + blowing air to blow the impurity off + Squeezing interaction + hybrid sheath (rigid and flexible)



Direction 4 : Hydrophobic tip cover + Absorbent material + wiping curtain method (trocar) + In and out movement of the laparoscope from the trocar.

Direction 5 : 5: Hydrophobic tip cover + Squeegee type cleaning /absorbing + wiping on other instrument + scraping action + flexible sheath

Direction 6 : Hydrophobic tip cover + Spinning the tip + button press interaction + Rigid sheath

Possible solutions for the whole device were sketched out in each combination formed from the morphological chart. These ideas are to be considered as directions and starting points to the development and not complete solutions. In the following explanation, the product idea behind each direction is briefly explained to convey the thought (figures 37 - 42).

**1: Hydrophobic cover + Blinking mechanism (like in the eye) + Squeegee/absorbent material + foot pedal/ trigger + rigid form factor**



This direction is inspired by the blinking mechanism of the eye. The eyelid goes over the eye during blinking and keeps the eye moist and clean. Similarly, this action is replicated at the tip of the scope by making the tip in a dome shape.

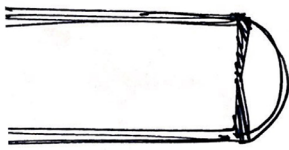

The dome is transparent to enable vision.

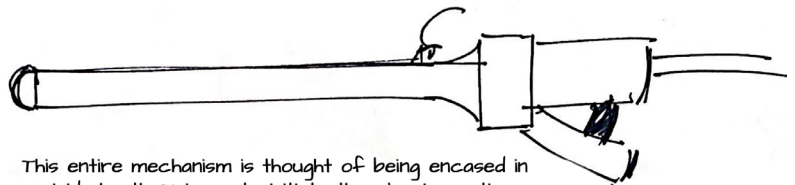

This entire mechanism is thought of being encased in a rigid sheath. Trigger to initiate the cleaning action, incorporated in the handle near the camera.

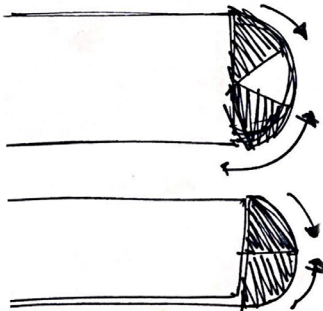

Pressing the trigger brings the flaps closer and inturn wiping the surface and cleaning it.

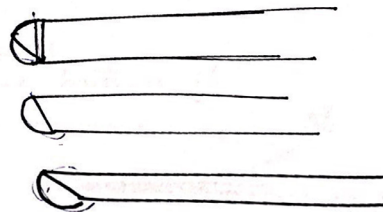

Dome shaped tip can be adjusted to various angles of the laparoscope.

Fig. 37 Direction 1

**2: Hydrophobic cover + Replacable /movable surface + button /trigger/footpedal operation + rigid form factor**

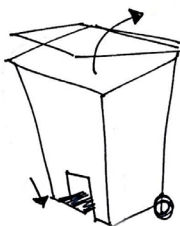

This direction focuses on changing of the surface when it gets dirty. There are two methods described for it. One is based on similar interaction as the foot operated dustbin.

Moving the surface : Pressing the button, opens the lid at the tip of the laproscope with force and dislodges the impurities on it. This action is similar to the dustbin operated with a foot pedal.

The lid is transparent to enable vision and also allow light to pass.



Replacing the surface: Pressing the button replaces the soiled surface at the tip of the laparoscope with a fresh surface. Thus it takes the impurities with it.

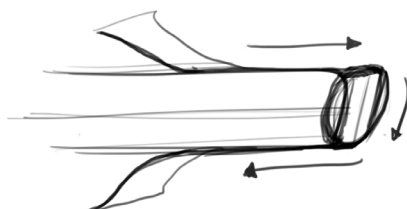

Tape like factor for continuous chain of new surfaces.

Fig. 38 Direction 2



3. Hydrophobic tip cover + blowing air to blow the impurity off + squeezing interaction + hybrid sheath (rigid and flexible)

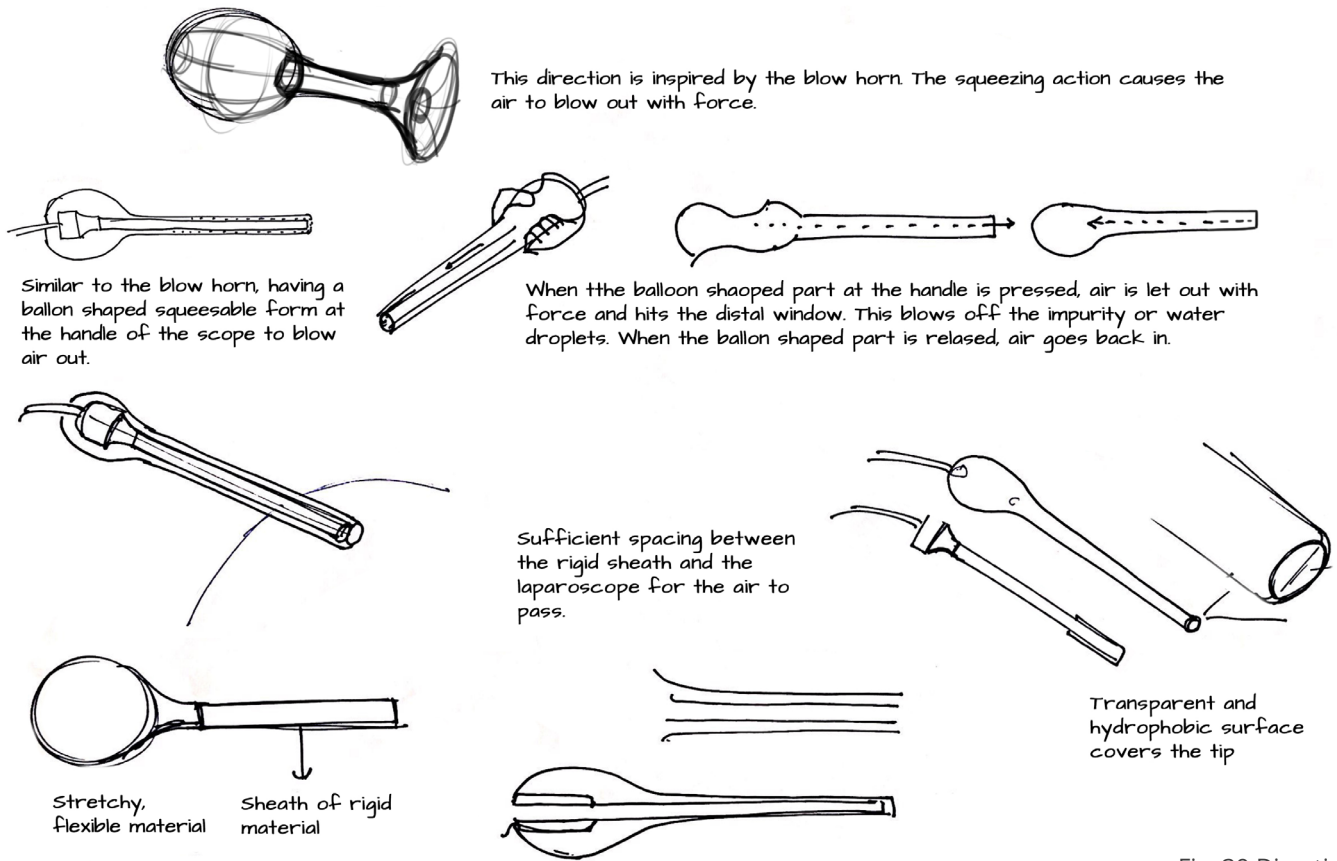

Fig. 39 Direction 3

4: Hydrophobic tip cover + Absorbent material + wiping curtain method (trocar) + In and out movement of the laparoscope from the trocar.

In this direction, a stretchable wiping sleeve is put over the trocar. This acts like a wiping curtain. When the laparoscope is withdrawn back in the trocar the impurities at the tip are wiped off on the inner absorbent side of the sleeve. The trocar can be pushed out of it to continue again with the surgery.

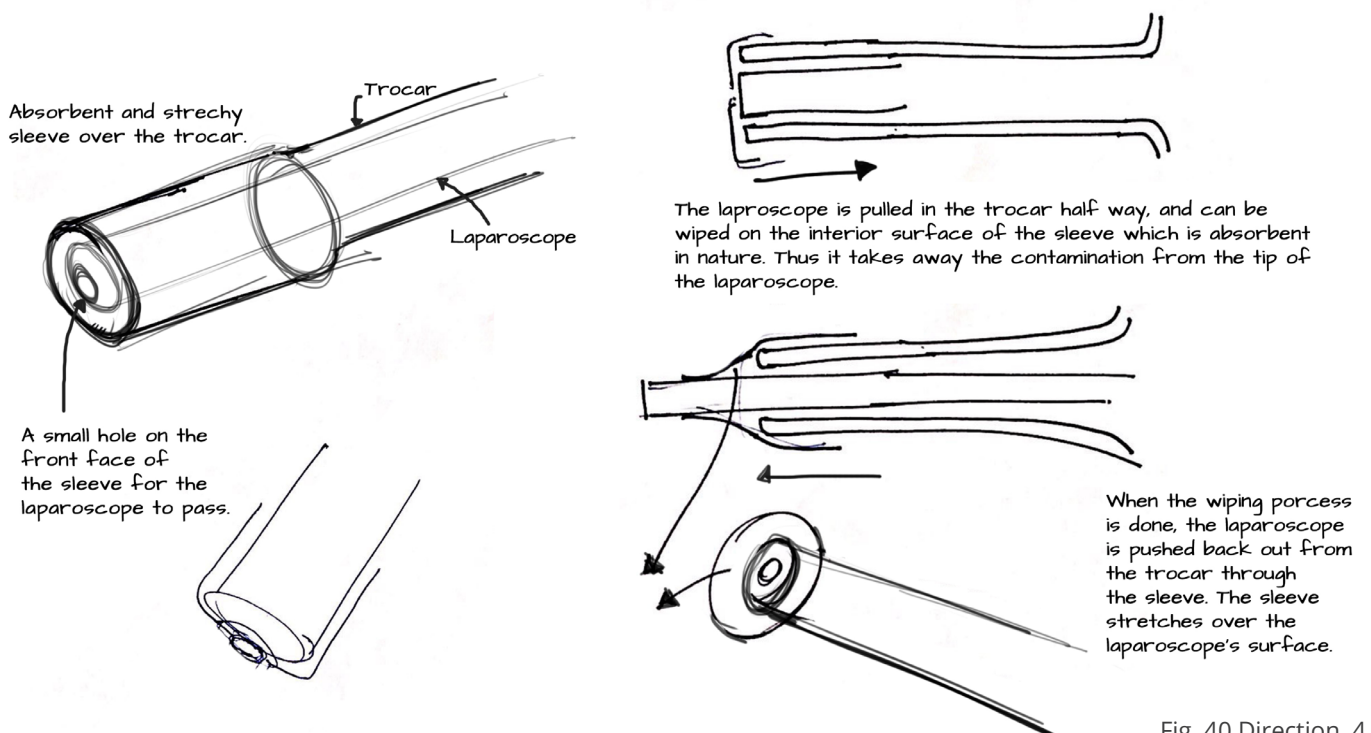

Fig. 40 Direction 4

5: Hydrophobic tip cover + Squeegee type cleaning /absorbing + wiping on other instrument + scraping action + flexible sheath

This direction utilizes the instruments present in the operative field to clean the tip of the laparoscope by scrapping it. Upon contamination, the laparoscope is brought close to the other instrument with a wiping patch and the laparoscope is rubbed or scraped on it to clean its surface.

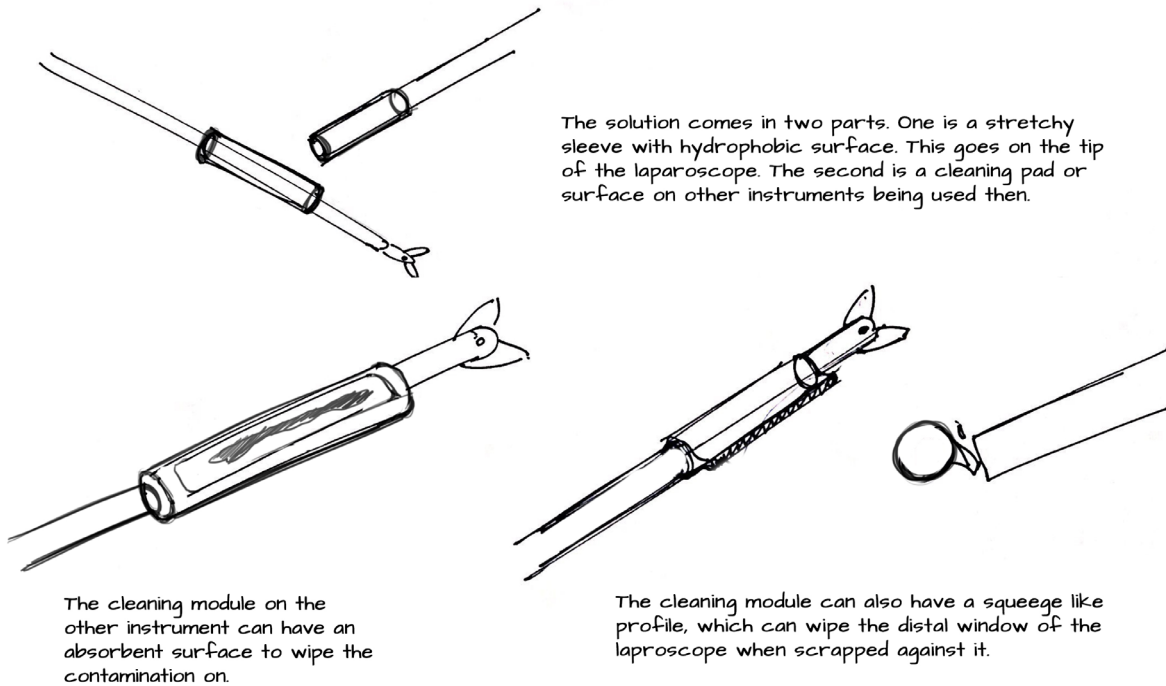
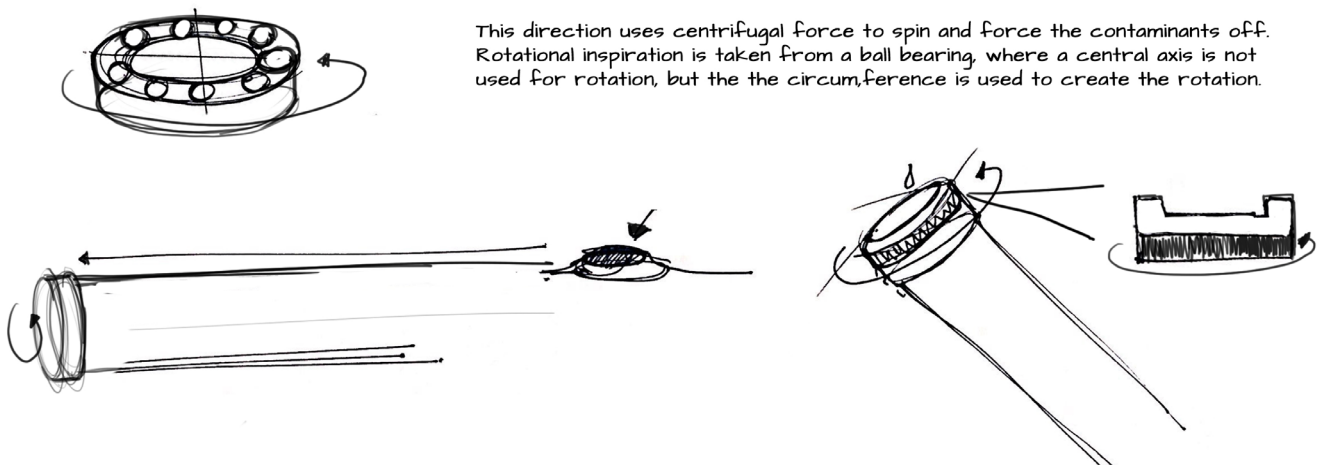

Fig. 41 Direction 5

6: Hydrophobic tip cover + Spinning the tip + button press interaction + Rigid sheath



When the button is pressed, a rotational motion is created in the attachment at the tip. To facilitate this motion the mechanism is encased in a rigid sheath. This, results in a centrifugal force and the impurities are thrown away.

Fig. 42 Direction 6

## 7.3 Choosing a direction

To make a well informed choice of the design direction, two ways were used - elaborate discussion with the team at Pontes Medical and analyzing the directions with the list of requirements generated previously.

A discussion was conducted with Luuk Evers and Leon Neve from Pontes Medical to choose a suitable design direction. Their past experience in this project helped to give feedback on which direction seemed feasible and not explored previously. This helped to expedite the selection process. Each direction was first explained and then positive aspects and negative concerns for each of the direction were noted down. The raised negative concerns were analyzed to see if they can be solvable at an early stage in the design process. As having the concern till the later stage might be a risk. This analysis is summarized in the table below (figure 43).



					
<ul style="list-style-type: none"> <li>▶ Can target fatty substances which are most stubborn contaminants</li> <li>▶ Hydrophobic and dome shape surface at the tip might allow the liquids to slide off</li> <li>▶ Moving part inside the body</li> <li>▶ Saturation of the absorbent wiper after certain wipes</li> <li>▶ Liquid can redraw on the dome surface due to the wiping action</li> </ul>	<ul style="list-style-type: none"> <li>▶ Can easily provide a clean view from fatty substances by changing the surface</li> <li>▶ No free moving parts inside the body</li> <li>▶ Saturation or depletion of the movable film</li> <li>▶ Crumpling or creasing of the film</li> </ul>	<ul style="list-style-type: none"> <li>▶ Very intuitive squeezing interaction</li> <li>▶ Not easy fixing of the stretchable cover over the scope</li> <li>▶ Might not target fatty contaminants</li> <li>▶ Refilling of air everytime its squeezed is tricky</li> </ul>	<ul style="list-style-type: none"> <li>▶ Intuitive and fast interaction.</li> <li>▶ Very easy to setup solution</li> <li>▶ Inexpensive solution</li> <li>▶ Restricts insufflation air flow</li> <li>▶ Liquid contaminants might draw back on the scope tip during the cleaning action</li> <li>▶ Fatty substances might not comeout completely.</li> <li>▶ Losing of position in the operative field</li> </ul>	<ul style="list-style-type: none"> <li>▶ Very cost efficient and simple solution</li> <li>▶ Co-ordination between instruments during surgery</li> <li>▶ Wiping has to be done in specific angles to remove the dirt, might not be possible in every situation.</li> <li>▶ Fatty solid particles can be tackled during scraping of wiping action</li> </ul>	<ul style="list-style-type: none"> <li>▶ Free moving part inside the body</li> <li>▶ Fatty solid particles might not dislodge completely from the surface.</li> <li>▶ High speed moving part not to safe if touches an organ accidentally</li> <li>▶ Might not work for all angles of scope.</li> </ul>

Fig. 43 Analysis of the design directions

From the analysis, direction 1 and direction 2 were thought to be feasible and the concerns could be addressed and solved at an early stage in the design process. The directions 3-6 involved crucial contextual problems such as blocking of insufflation air, losing the position and view in the operative field, increased task of coordinating between instruments, high speed moving elements. However, direction one and two had more design problems which can be solved during development. During these discussions, some more requirements were recognized and were added to the previously formed list of requirements. They were:

- The solution should be cable-free, as this will help to reduce clutter in an already crowded environment.
- The solution should allow the scope to be in the same position always and not lose the operating view at all.

These directions were then also evaluated with the new list of requirements.

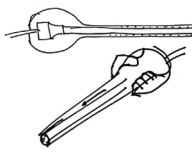
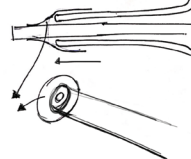
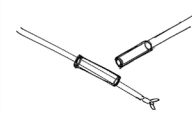
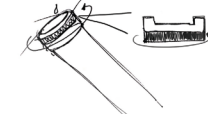
The first two directions were then analyzed with the updated list of requirements. Firstly, the efficiency of both the direction was checked, which meant the ability to get rid of stubborn contaminants like fatty substances and blood splashes. Direction 2 seemed most efficient as it completely changed the surface whereas direction 1 still had the possibility to not clean properly and need many wipes. Second aspect was the safety aspect. Both the directions involved moving components. Direction one had the wipers which moved and direction 2 has the film. However, direction 2 does not include free moving parts which have the risk of falling inside the abdomen unlike direction 1. Lastly, the compatibility of the proposed directions with scopes of different angles and diameters. Here as well, direction 2 seemed more feasible to adapt to various dimensions. The dome and wiper feature of the first direction makes the compatibility difficult.

## Conclusion

Based on the discussion and evaluation, direction 2 was chosen to explore further. This direction was similar to the previously thought direction of movable surfaces. This direction efficiently gets rid of the fatty impurities as the surface is changed completely while giving the possibility to fulfil the rest of the requirements during the development phase. This exercise confirmed that the previously thought direction seemed feasible to venture into.

## 7.4 Exploring the chosen direction

Before starting with conceptualization, a few aspects concerning the design directions were further researched and explored. This helped gain all the inputs required for creating a concept. The activities done are described below.

### Exploring the hydrophobic material

Superhydrophobic materials mentioned by Park, Park, & Lee, 2018; Sunny et al., 2016 are commercially not yet available and still require further development. Therefore, similar contexts where hydrophobic material might currently be used were explored. One such context is that of action cameras. Action cameras are designed to be able to record in rugged conditions. In this case, also a clear vision is very important but at the same time, the surroundings in which it is used makes the screen quite dirty. GoPro is the most popular action camera. It is also used to shoot underwater. ClearX hydrophobic screen protectors are available, especially for this purpose (figure 44). They help to protect the lens and screen and repel the impurities falling on it while providing a clear vision for the photograph or video. This application is very close to the need in the context of laparoscopy. Hence, these screen protectors were considered for testing.



Fig. 44 Clear X GoPro Hydrophobic screen protector

The aim of this test is to check the capability of ClearX Hydrophobic screen protectors in the context of laparoscopy. How well can it repel blood and water and what are the factors which help to achieve a clean screen? A test setup was created and the hydrophobic screen protectors were tested with water and fake blood (figure 45). The details of the test can be found in appendix N. The test revealed that the ClearX hydrophobic protector helps to handle the liquids in a better manner by not letting it spread on the surface. In contrast to the current situation when the liquid comes directly in contact with the glass tip of the scope, it spreads further and adheres to the tip. This makes cleaning more difficult (figure 46). Thus even with lesser capacity than superhydrophobic materials, these protectors can be really helpful for the solution and can be integrated at the crucial areas on the tip.

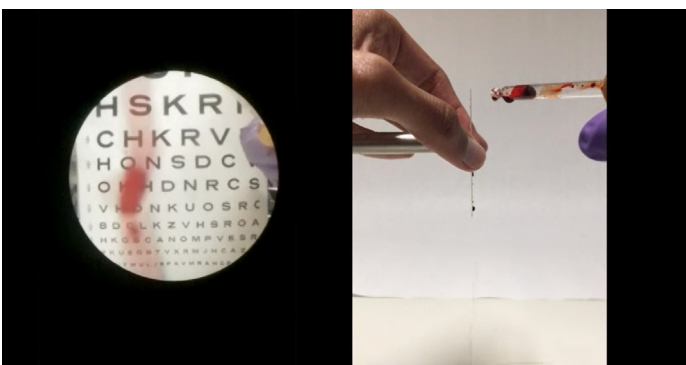

Fig. 45 Recording from the test.; blood being applied on the tip.

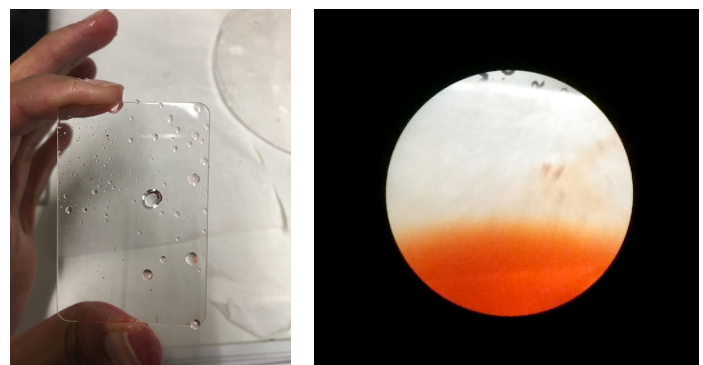

Fig. 46 Non spreading droplets on the hydrophobic protector (left); liquid spreading on the tip of the scope (right).

## Exploring the interaction method

A trigger or a button style or foot pedal actuated interaction was the chosen way to operate the cleaning device. However, since having a cable free solution is the requirement, the foot pedal interaction style was discarded at the beginning itself.

The button method indicates the need for electronic components whereas the trigger method would point towards a manually operated solution. In order to make a decision between these two, sketches explaining possible solutions with both the method were made. These sketches summarized the information gained so far and provided an overview of the design to make a decision. Figure 47 shows the sketch. Using these sketches, a discussion was conducted at Pontes Medical to make an informed choice. Both the systems were analyzed on several factors such as their feasibility, processing after the surgery, etc. It was concluded to have a manually operating system. This was so because an electronic system would imply the need for power. It would either have to be charged beforehand or need batteries or need an extra plug connection in the OR. The scrub nurses would have to ensure this. Having a plug connection in OR will clutter the already crowded environment. Furthermore, it would also demand different disposal methods as it would be a hybrid electronic waste after use. All these aspects of the electronic operating system would create a rather complex system for the purpose it offers. The manually operated system could provide a much simpler solution, with no preparation required. This will match the surgeon's perception of the problem discussed in chapter 2.2. Also, it could be made in one material to create a simpler way of disposal. Hence the decision to develop a manually operated system was taken. This implied that the trigger is the chosen style to actuate the cleaning action.

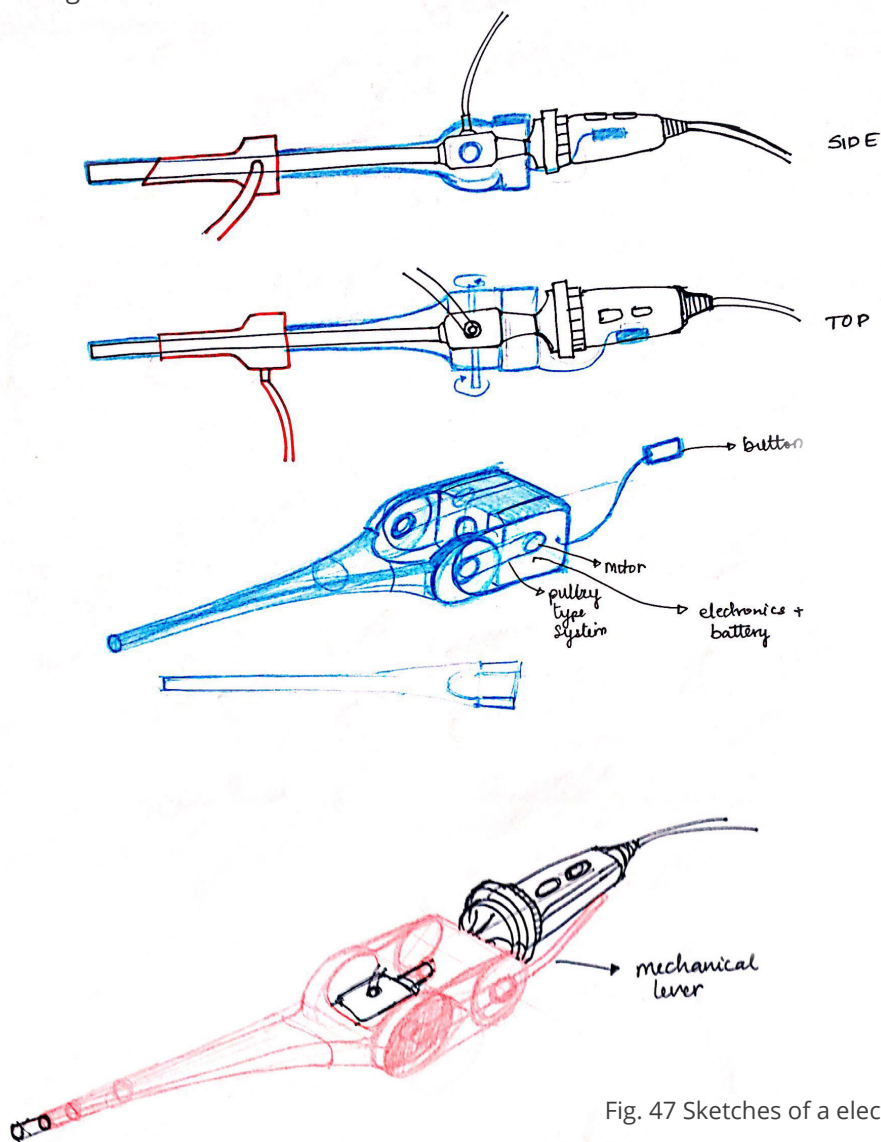

Fig. 47 Sketches of a electronic and mechanical system

Taking this and the previous conclusions into account of no standard holding style and awkward postures of holding, it was decided to create a holding method in the device which would help to standardize the way the scope is held and also enable to actuate the trigger to clean the tip at the same time. Considering this, three mockups were made with different ways to hold the scope (figure 48).



A. Vertical handle

B. Horizontal handle

C. Rotatable handle

Fig. 48 Foam mockups of the three handle designs

The vertical and rotatable handles were created with a view of always maintaining a neutral posture. The idea behind the horizontal handle was to incorporate the handle with the existing form factor.

Upon discussion, it was concluded that the vertical handle and the rotatable were totally different ways to hold the scope. Though they complied with ergonomic principles and maintained neutral postures, they would be a radical new change in the current way of working styles of the surgeons. This could not be very welcoming as the lens tip cleaning device is already a new addition in their working method.

Thus, it was decided to go in the direction of the horizontal handle, which would still allow them to hold the laparoscope in their way. Though this option did not completely support the ergonomic principles, it was thought to be more accepted. Moreover, the surgeons were used to the awkward postures. Hence going with their existing methods of holding the scope, and to have a less learning curve seemed more efficient.

## Exploring the mechanism

To realize the chosen interaction style of pressing a trigger, a supporting mechanism is required. The pressing of the trigger will initiate the cleaning action at the tip of the scope. The cleaning action refers to the moving of surfaces at the tip. Therefore, the device has to transfer the input provided by the user with the trigger as an output of a surface change at the tip of the scope while its inside the patient. For this purpose, products with similar interaction styles were explored, and the mechanism supporting it was studied. One such product was the automatic tape dispenser (figure 49). Upon pressing the trigger, a set amount of tape was dispensed.

It was learned from this product that the underlying basic mechanism is the ratchet mechanism. A ratchet based system allows movement in one direction only upon providing a manual input through the trigger. There were channels to guide the tape to its destination. It also incorporated tensioners to ensure the tape doesn't crumple or loosen along the way.

Similar functioning is envisioned in the case of laparoscope lens cleaning as well. The mechanical system in the device would also require to advance a fresh surface upon the press of the trigger. This surface would be in the form of a continuous transparent tape which will allow clear vision as well as the possibility to move on user demand. The tape would have to be guided to the tip and tension has to be maintained along the length of the tape for it to not slip away. From this study the movable surface had taken the shape of transparent continuous tape which will be wrapped on the spools in the mechanism.



Fig. 49 Automatic tape dispenser (“Handheld Tape Dispenser: Pull and cut tape in a single motion,” n.d.)



## 7.5 Refining the design direction

From the learnings of the exploration activities, the functioning of all the elements involved in this design direction could be charted out. In an event of contamination, how the solution should function is explained in the figure 50. The grey line marks the flow of the surgery. The red portions are disruptions in that flow during the surgery due to contamination of the lens tip. One of the disruption is zoomed into and a situation with the envisioned solution in the chosen direction is established.

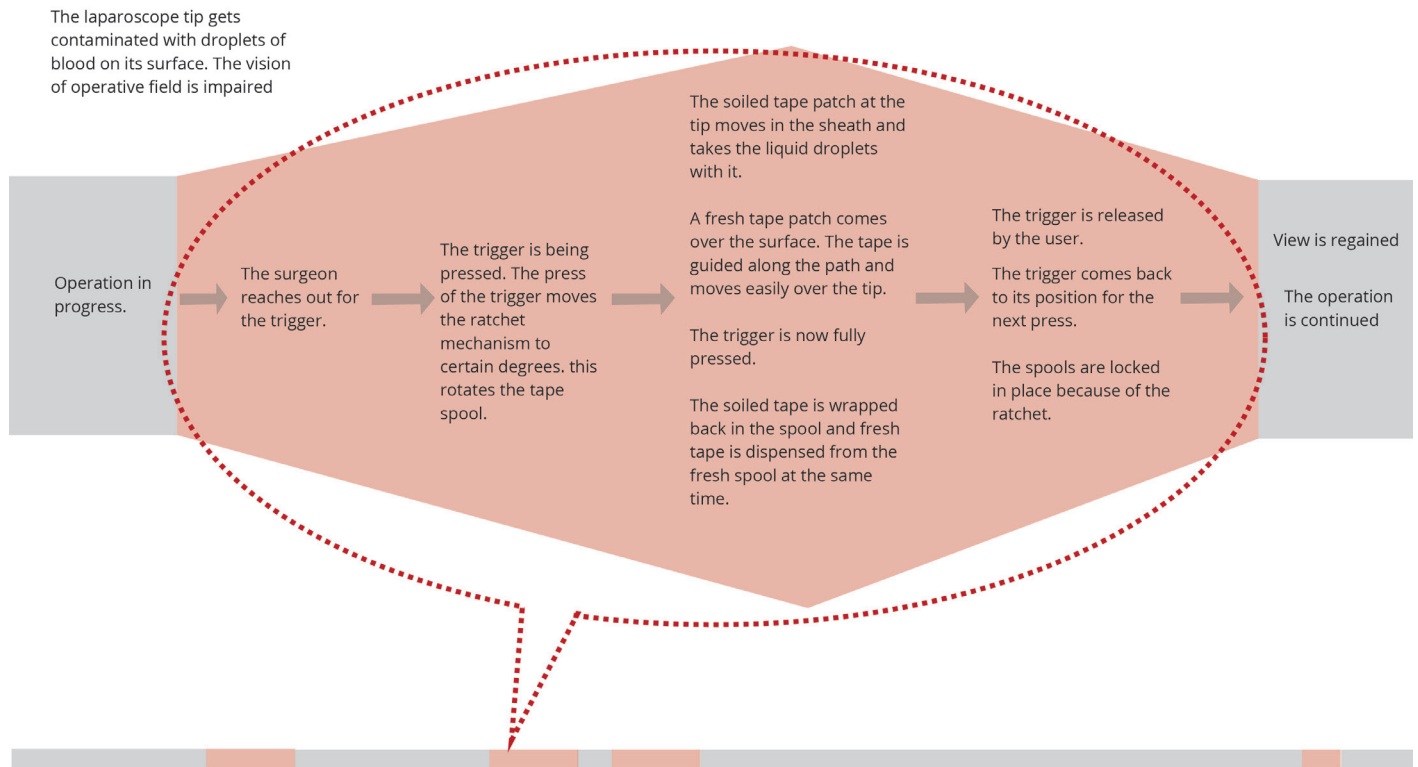
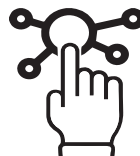

Fig. 50 Function analysis of the envisioned solution

From this function analysis, three distinct modules can be identified - The device tip, the device interaction and the mechanism. Each module has its own set of functions to perform while also supporting the other module. A synergy between them would ensure a efficient and easy to use solution. To develop each of these modules deeper and maintain an overview of the solution, the solution space was split into these three parts.



The device tip



The device interaction



The mechanism

As the decided project approach in chapter 1.4 was to start from clinical needs, rather than the technology, this was also followed in the conceptualization and develop phase. To create a holistic solution, the device interaction was important to address first. Once the desired and ergonomic interaction was found then an appropriate mechanism to achieve that particular interaction can be developed. The design of the device tip can be developed simultaneously as the happenings at the tip dictates the way the interaction and the mechanism will perform. Throughout the development process it is essential to keep in mind the interdependancies of the modules, and that the finding of one can be an input for the other.

# CONCEPTUALIZATION





## Preliminary concept

From the refined direction, a feel of the solution was developed. In order to get a first visual impression of the device this understanding was moulded into a preliminary concept. This concept helped to visualize the findings and gave a tangible form to the idea. In this chapter this preliminary concept is explained, the areas which need to be developed within the preliminary concept are identified. These areas are further developed through ideation and preparing mock prototypes. This chapter concludes with a refined concept which is ready for the development phase.

8.1 Concept explanation

8.2 Identifying areas to develop

8.3 Ideation on those areas

8.4 Refined concept

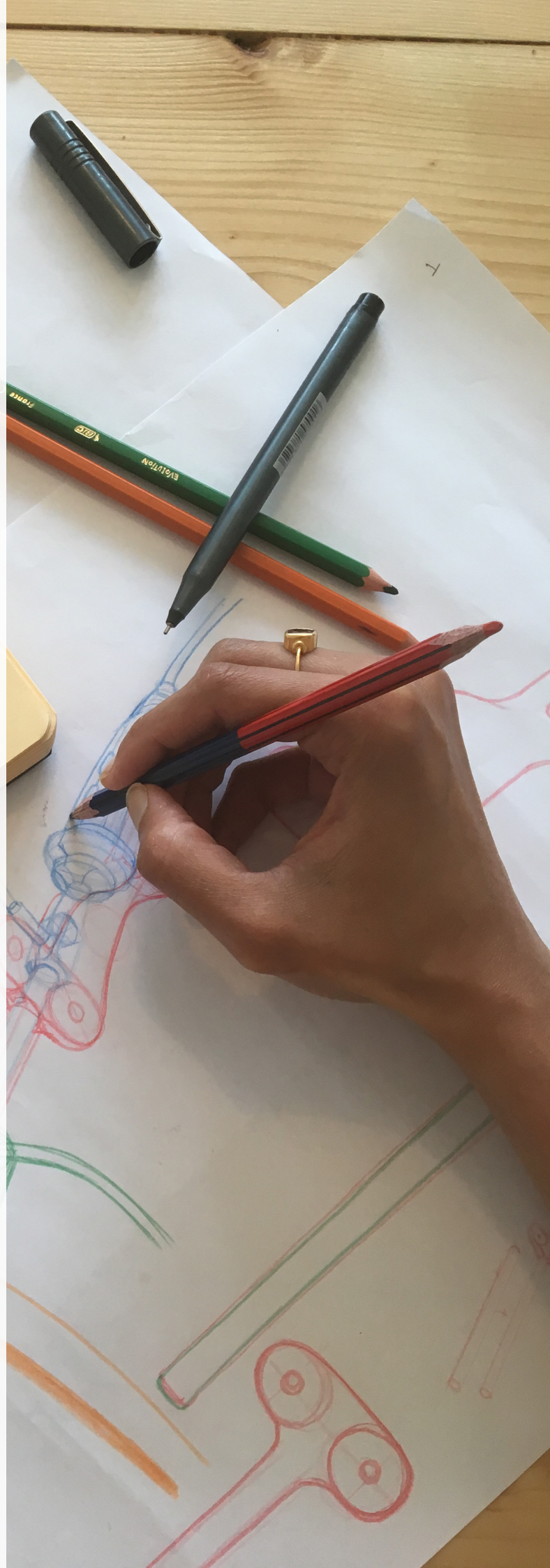

## 8.1 Concept Explanation

The preliminary concept is explained in detail in this chapter. This concept follows the functional breakdown explained in the figure 51. An elongated sheath runs over the length of the scope.

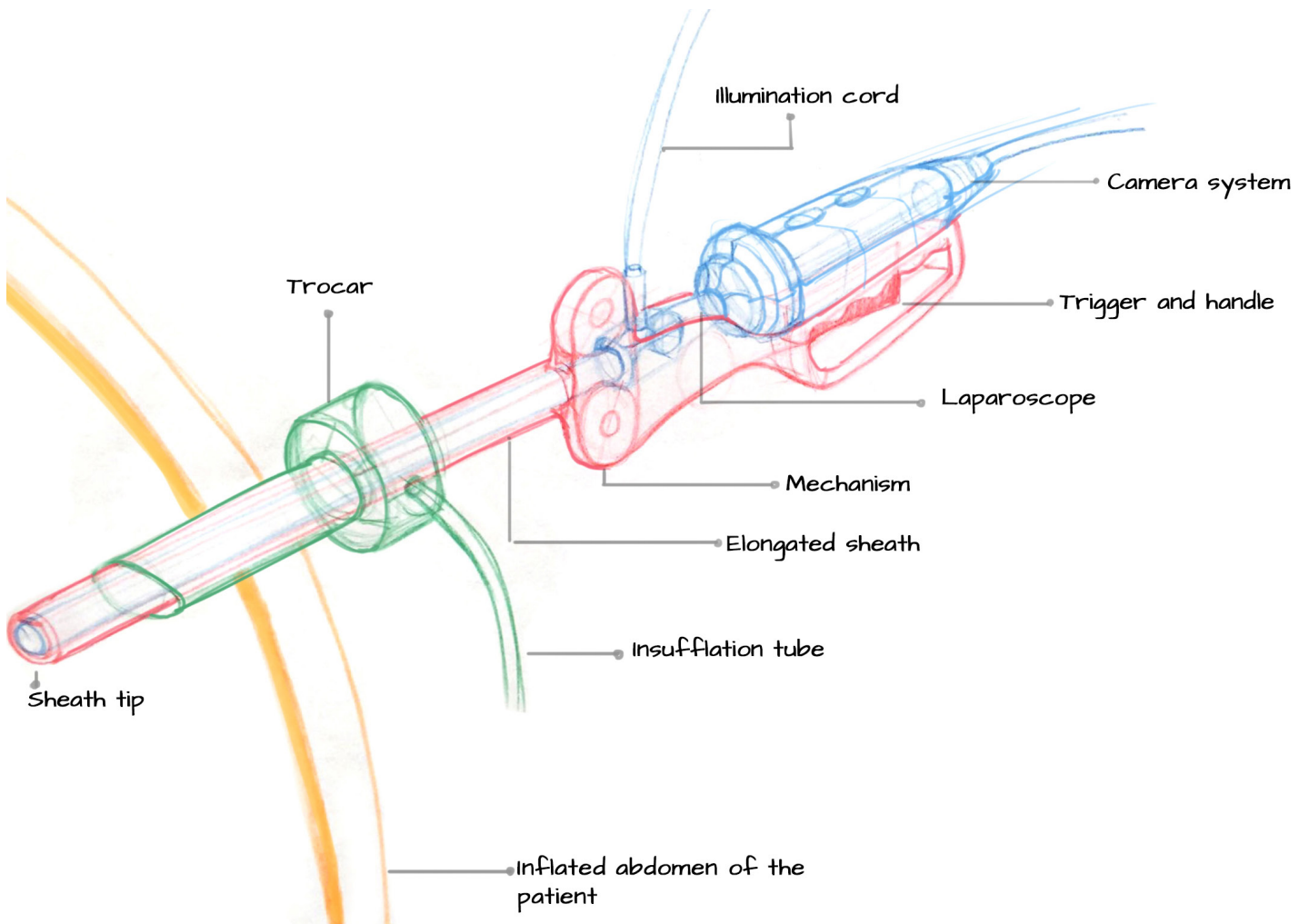

Fig. 51 Preliminary concept

This sheath helps to guide the tape from the mechanism at its rear end to its tip in the front (figures 52 and 53). This mechanical system consists of a ratchet mechanism and spools for fresh and soiled tape. The spools are placed on either side of the sheath. Fresh tape from the top spool is passed over the length and the tip of the scope and is wrapped over the other spool. The rotation of the spool is controlled with a ratchet. This ratchet is operated on demand by an arm. This arm extends to become the trigger which will be operated by the user. This trigger sits in a handle-like structure which is a part of the casing. This handle is below the camera system (figure 53)

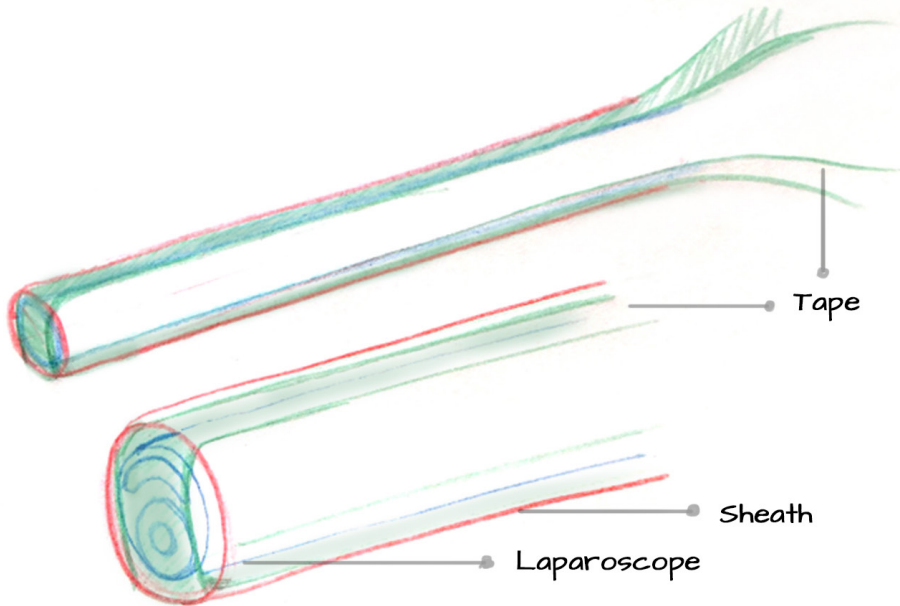

Fig. 52 The sheath and the tape at the tip of the laparoscope

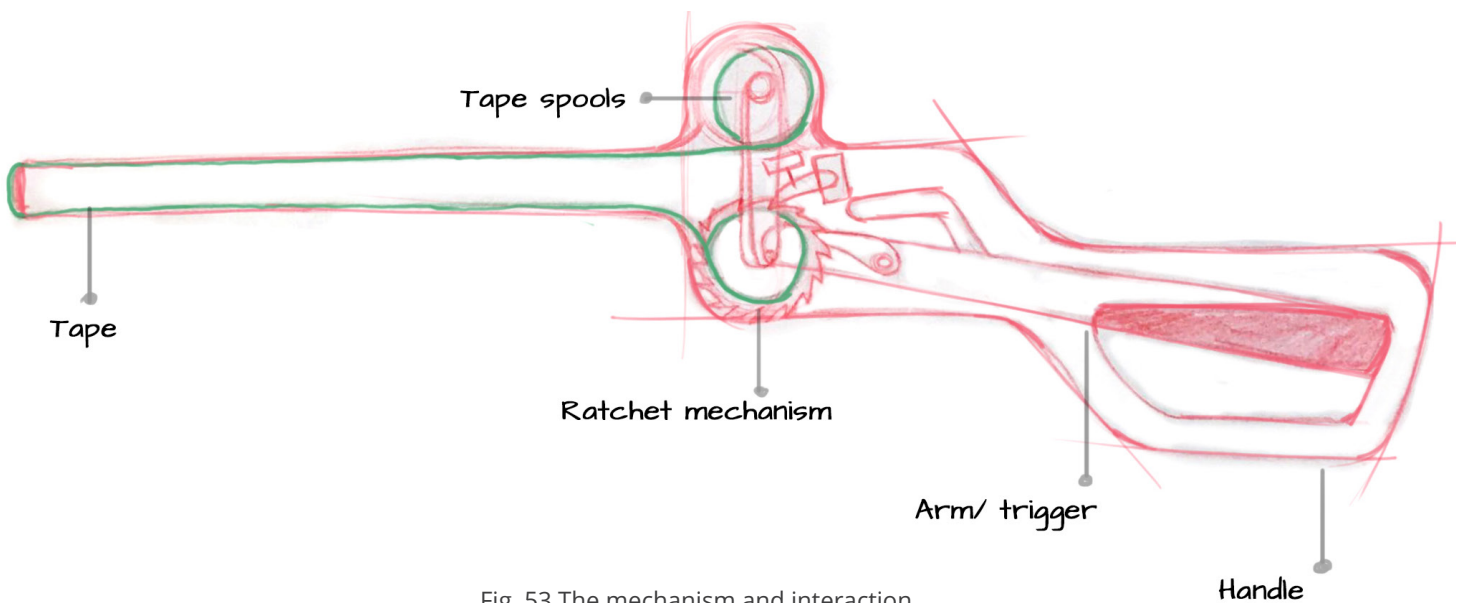
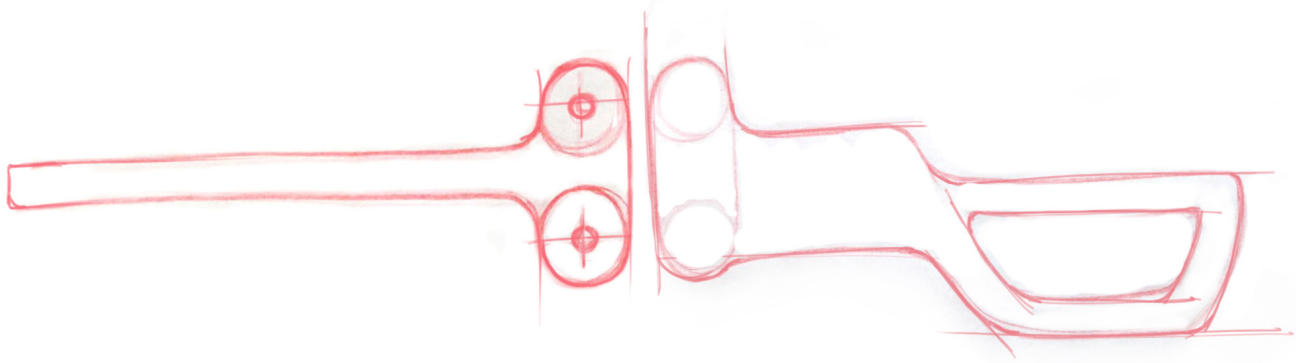

Fig. 53 The mechanism and interaction

This concept is in two-parts (figure 54). The sheath and tape part can be discarded after use and the mechanism and trigger part can be reused after the appropriate cleaning procedure,



Sheath and tape

Mechanism, trigger and handle

Fig. 54 Two part design

## 8.2 Identifying areas to develop

To advance the concept further, it was essential to understand which elements needed to be worked on and to realize the potential risks early on. For this, each module (the tip, the interaction and the mechanism) was analyzed and potential concerns and development areas were discussed (figure 55). This helped to ideate on them in a more structured way. This discussion was carried out with Herke Jan Noordmans, a clinical physicist at the Facilitair Bedrijf, Medische Technologie en Klinische Fysica at UMC Utrecht. He has experience working on projects related to the laparoscope. The concept was explained to him initially and then each module was discussed together. The discussion is visualized in the figure xx below and elaborated further:

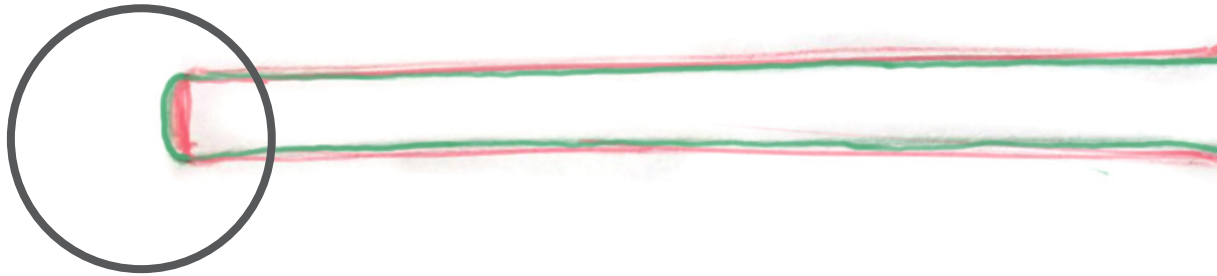

Tip and sheath:

- 1) Creasing of the tape when it passes over the tip: While changing of surfaces, if the tape creased or crumpled, it might result in jamming of the mechanism and impairing the view. Thus at all times, the tape has to be maintained straight at all times.
- 2) Tape not adhering to the tip surface properly: If the tape does not adhere to the surface, liquids might flow in between the tape and the glass surface of the scope. This will be difficult to handle as the liquid might continue adhering there due to capillary action. Thus the tape has to have appropriate tension to adhere on the surface of the tip.
- 3) Tape slipping off to the sides in the sheath: If the tape is not guided well, it might slip in the sheath. This will result in contamination of the fresh tape and tape getting entangled. So the tape has to be guided from the mechanical system to the tip and back.
- 4) Friction between the tape and the sheath: if the surfaces are rough, friction might lead to unsmooth movement of the tape. This will require additional strength from the mechanical system.
- 5) Scrapping of the dirt on the sheath while the tape is entering the sheath: The soiled tape entering back in the sheath might scrape larger impurities on the rim while entering through the slot on the sheath. This will result in an accumulation of dirt at the tip. Therefore, the slot for the soiled tape has to be little bigger and away from the tip.
- 6) Tape getting crumpled if the scope accidentally touches an organ or a tissue: During operating the scope accidentally touches the tissues sometimes. During this situation, the tape should not get crumpled at the tip or move from its position. So there should be a barrier which will touch the tissue before the tape.
- 7) Matching the critical tolerances between the trocar and scope: The tolerances between the trocar and sheath are very crucial. There has to be enough room for the insufflation gas to flow, allow easy movement of the scope with the sheath on in the trocar and not compromise on the freedom of movement of the scope.



Fig. 55 Identifying development areas

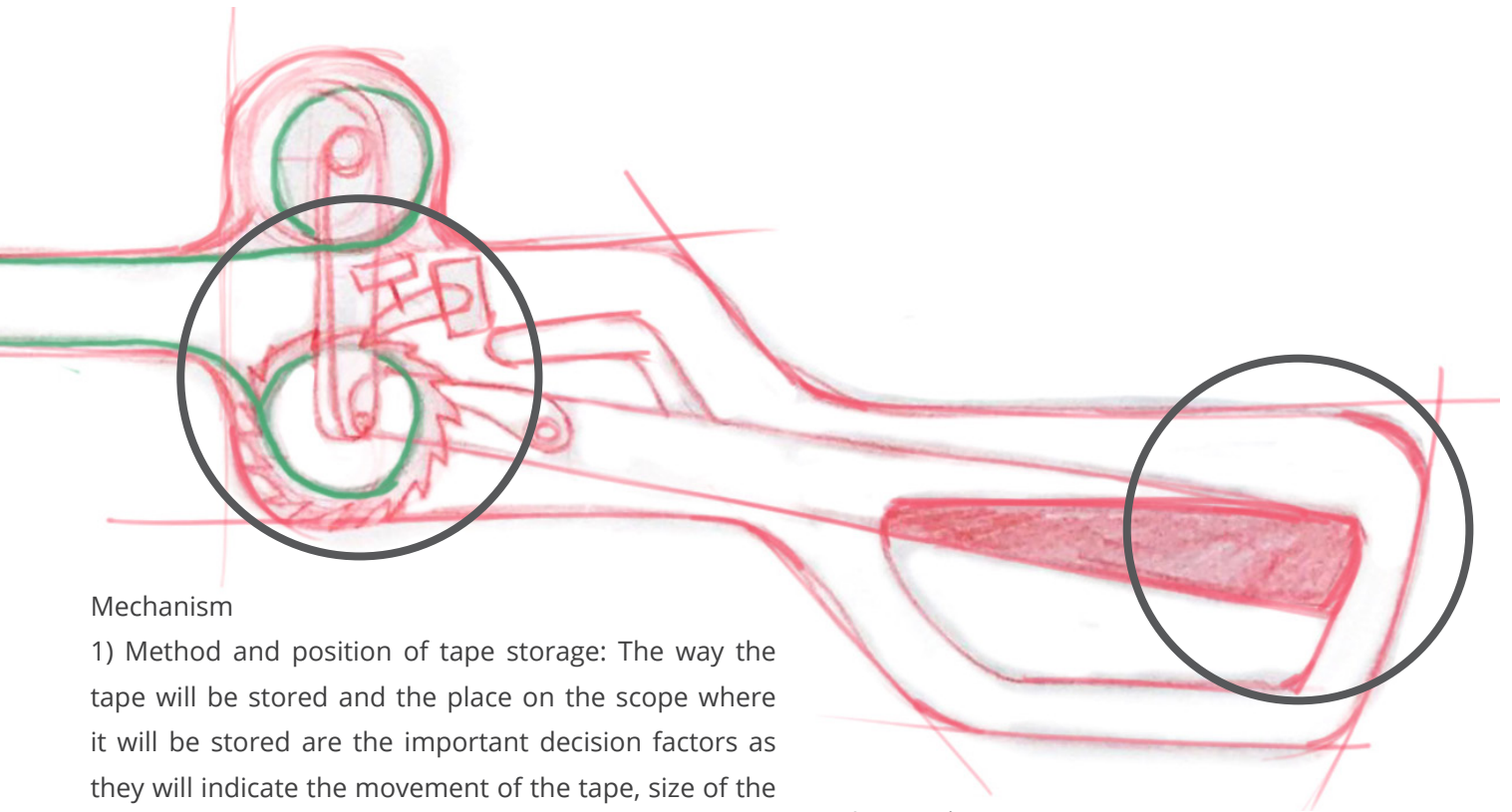

#### Mechanism

1) Method and position of tape storage: The way the tape will be stored and the place on the scope where it will be stored are the important decision factors as they will indicate the movement of the tape, size of the device, easy interaction, etc.

2) Maintaining tension on the tape: In order for the tape to not crumple as mentioned in the tip and sheath section, appropriate tension will have to be provided by the mechanism system.

3) Fixating the device on the scope: Once the device is placed on the scope, it has to be fastened in that position, to stop it from rotating. This will be a crucial step in the preparation of the device before surgery.

4) Connecting of the sheath to the mechanism: The sheath and the tip design has to be connected in a seamless manner, such that the tape can pass from one to another in a smooth and efficient way. This could also look into the easy disassembly of the device.

5) Translating the trigger input into mechanical movement of the ratchet: Defining the aspects of the mechanical system which will be involved to carry out the whole cleaning action will be important for the engineering the device later.

#### Interaction

1) No standard dimensions to base the design on: As discussed in chapter 4.3, where the ecosystem of the laparoscope is studied, it is clear that there are no dimensions on which the design can rely. Thus the trigger design will be independent of any dimensions. This way compatibility of the device to many scopes which is an important requirement can be achieved.

2) The trigger design: The design of the trigger will ensure easy actuation during the surgery. Hence the design has to be with the surgeon's reach easily operable.

## 8.3 Ideation on those areas

To address the points of development recognized before, a second ideation session was done at Pontes medical. This ideation was completely focused on this concept. Here different ideas within each module were brainstormed. During the brainstorming, large and quick sketches of the ideas were made on a whiteboard. Simultaneously with the sketching, they were discussed and further built upon. The white board images with the ideas can be found in appendix O. These ideas were summarized in a second morphological chart (figure 56)

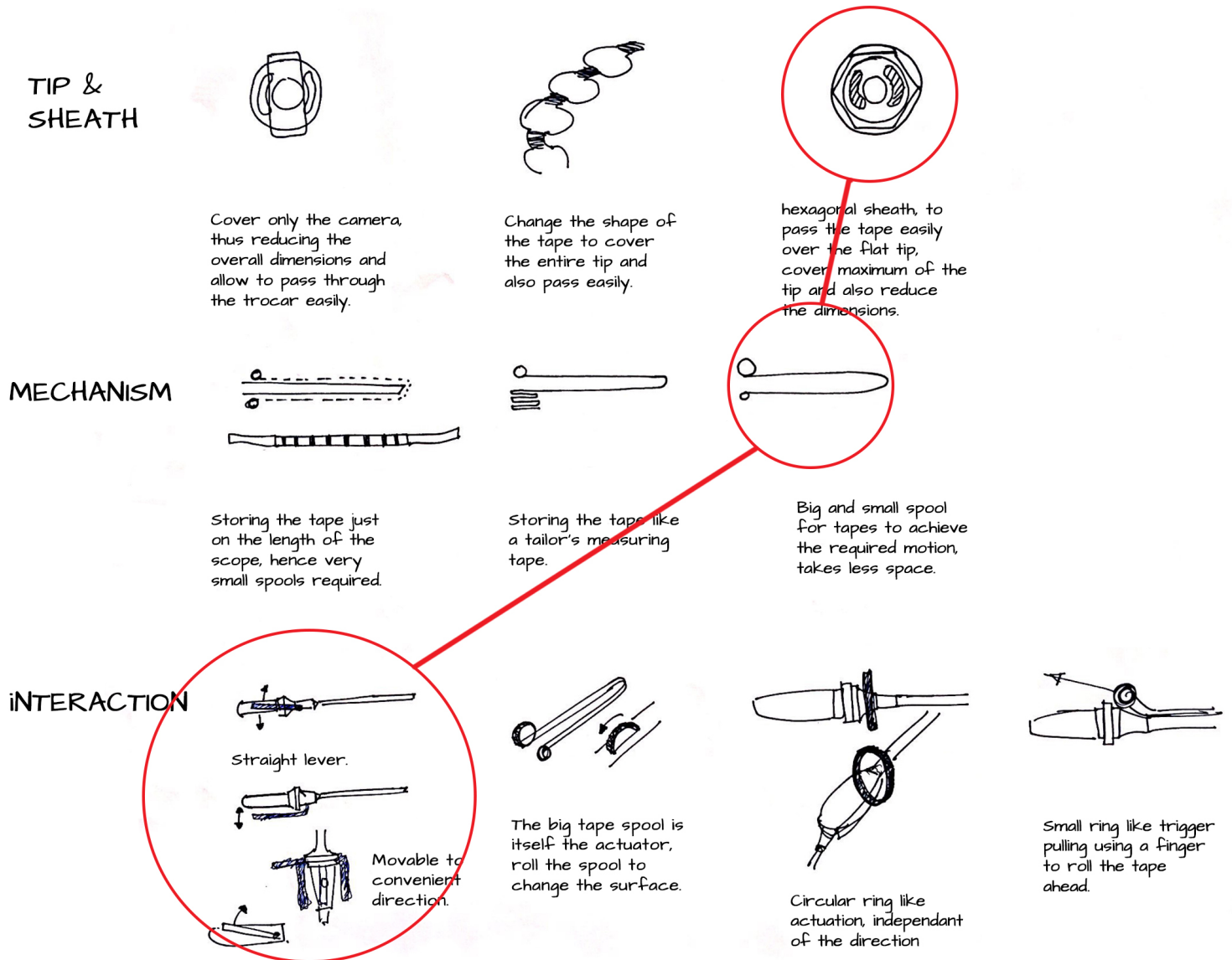

Fig. 56 Second morphological chart

From the above morphological chart, a combination of solutions from each category was chosen. This idea was to have a hexagonal sheath design along with a roll style method to store the tape. Together with these, the lever style of interaction was chosen. This decision was made based on the number of concerns each solution addressed and gave a further possibility for development. These chosen solutions were independently explored through mockups and finding inspiration from similar other products. The findings of these explorations helped to refine the preliminary concept. These explorations are described.

## The device tip

The chosen idea was having a hexagonal sheath and tip. To get a better understanding of the small details at the tip, a large scale mockup was made. This concept consists of a hexagonal inner sheath and a circular outer sheath (figure 57). The hexagonal sheath goes over the scope and the circular outer sheath goes over the hexagonal one (figures 58 and 59).

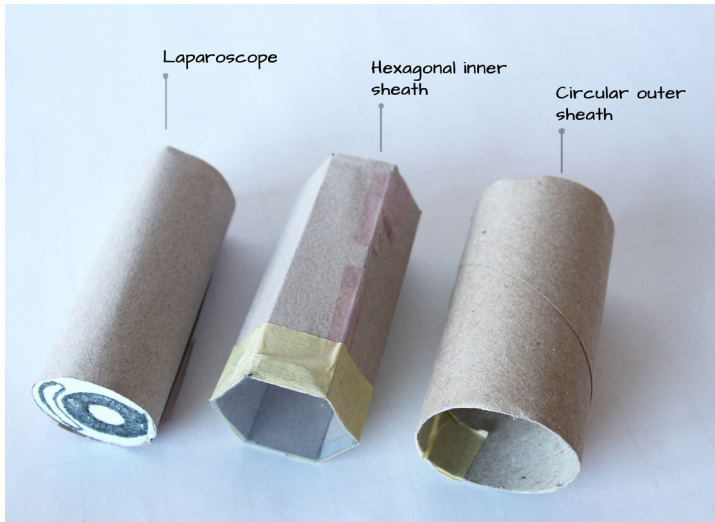

Fig. 57

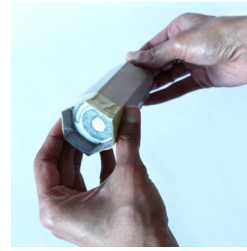

Fig. 58 Hexagonal sheath over the scope



Fig. 59 Circular sheath over hexagonal sheath

The hexagonal geometry of the inner sheath gives the tape the possibility to remain straight without creasing. This also reduces overall dimensions. The outer circular sheath prevents slipping of the tape by guiding it and keeps the tape intact (figure 60). The semi-circular area between the two sheaths will give room for the dirt to be carried with the tape instead of scrapping it over the edge (figure 61). The hexagonal sheath has a transparent cover which is made of hydrophobic material. This covers the whole face of the tip, thus prevents the liquid to adhere to the laparoscope surface.



Fig. 60

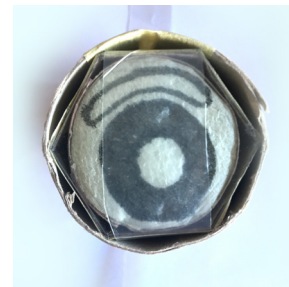

Fig. 61 Semicircular area between the sheaths

This configuration can be achieved for scopes with different angles (figure 62)



Fig. 62 Adapting to various angles

## The device interaction

As learned in chapter 4, there are no standard dimensions on the scope which be relied on to base the design of the device and also no standard way of holding the scope. To define an interaction for this device, a similar scenario with a trigger/lever interaction was looked for. Inspiration was taken from the way the handbrake of a bicycle is used (figure 63).

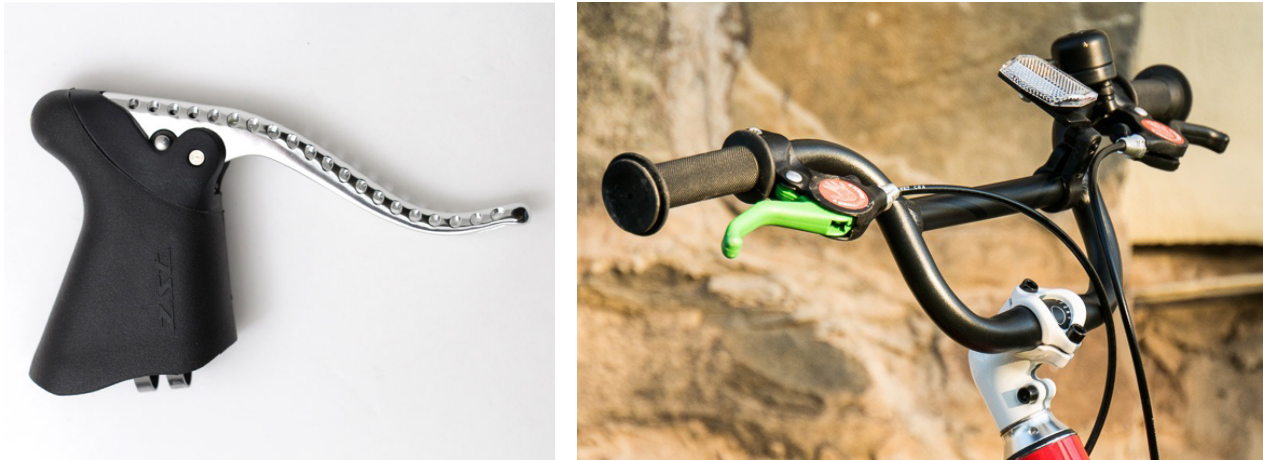

Fig. 63 Bicycle hand brakes

The user pulls the handbrake when required during biking, rest of the time only the handle is held (figure 64).



Fig. 64 Pulling the brake

The user pulls the handbrake when required during biking, rest of the time only the handle is held (fig. 75). Similarly, if the design of the trigger is such that it lets the surgeons, hold the scope the way they want and only when they need to change the surface on the occasion of a soiled tip, they can reach and press it, then it will create a easy to use solution. This will also ensure that they do not have to alter their current ways of handling the laparoscope and the design of the trigger is independant of the form of the camera or scope used.

## The mechanism

For understanding the mechanism, inspiration was taken from the correcting tape (figure 65). The correcting tape dispenses a white tape, the white part gets stuck to the paper while being rolled on paper and the leftover base of tape is rolled back in on to another wheel.

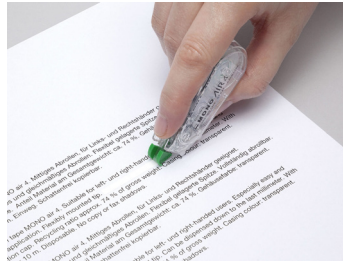

Fig. 65 Correcting tape

A similar system is needed for the device. Where one wheel rolls out the tape and the other wheel wraps it in simultaneously. Several correcting tapes were disassembled and studied (figure 66)



Fig. 66

The details of the wheel and the gear system in the corrector tape provides important insights which can be applied to the context of the device. Insights such as injection moulding of standard gears, method of fixing them and material optimization were learned. In all the tape configurations that were studied, the dispensing wheel was larger in size than the wrapping wheel (Figure 67). This was for the wrapping wheel to accommodate all the incoming tape. Thus the gears moving them maintained a certain ratio. This ensured that the wrapping wheel moved faster to wrap all the incoming tape.

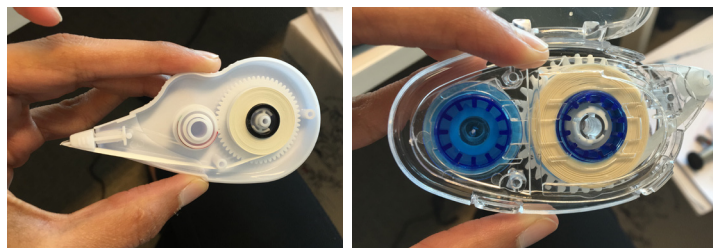

Fig. 67 Details inside the correcting tape

A similar arrangement could be used in the envisioned system. Mock setup was tried by disassembling a tape (figure 68)

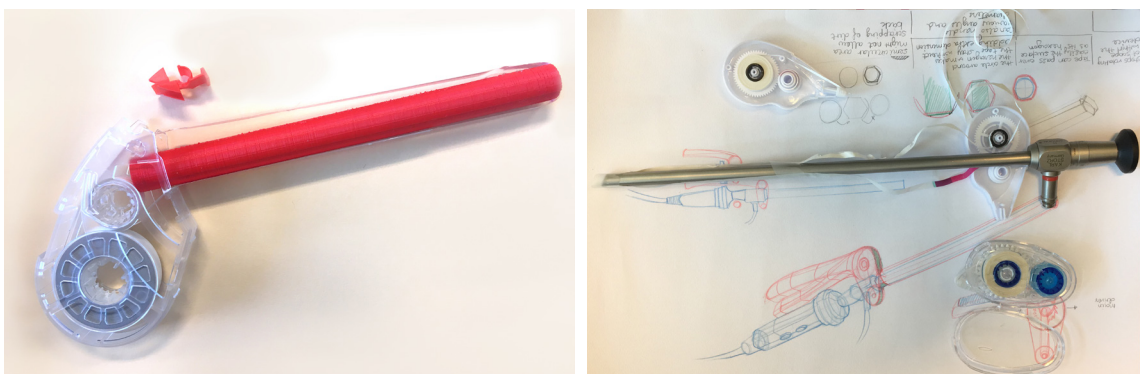
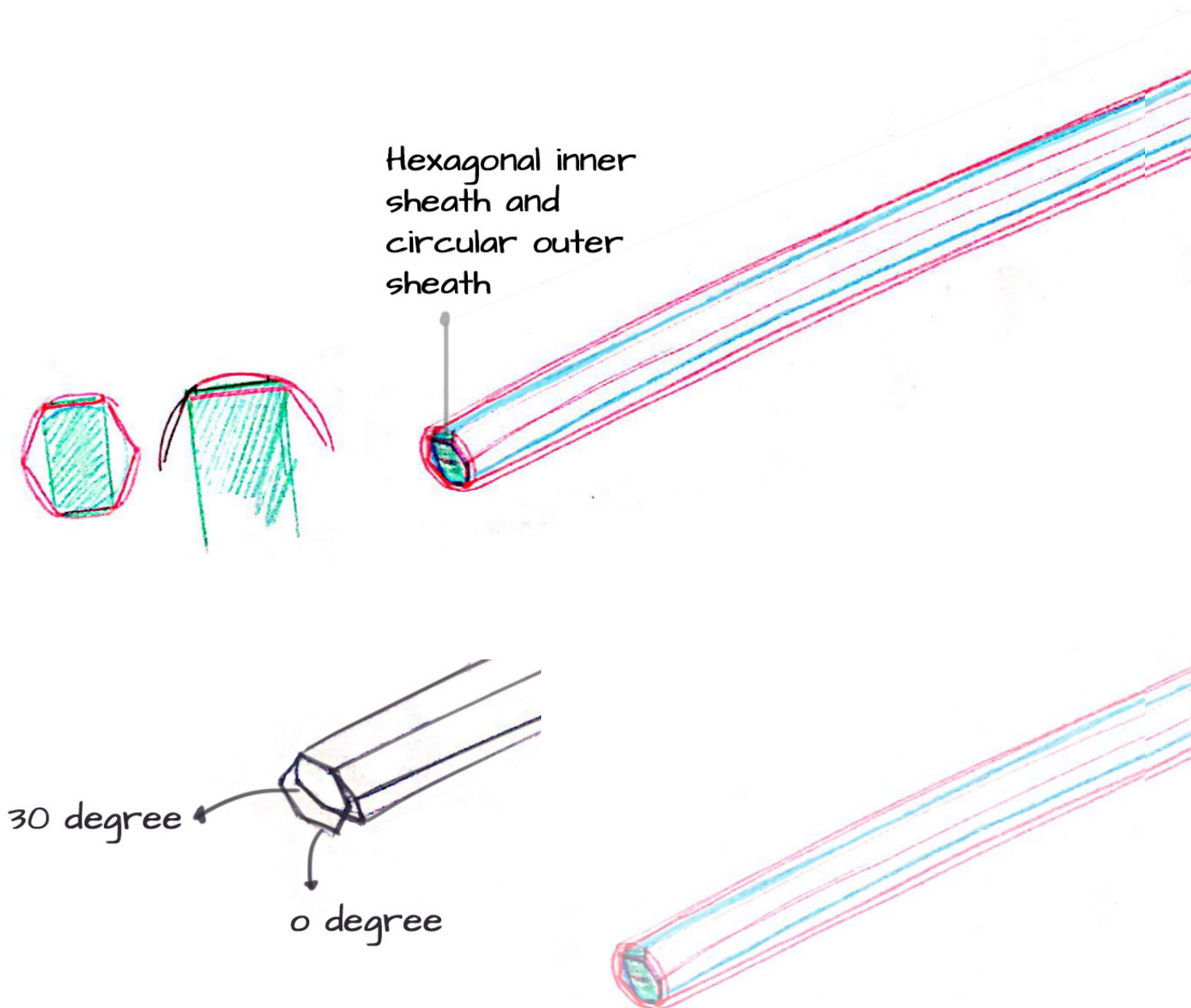

Fig. 68 Exploring the correcting tape

## 8.4 Refined concept

The ideation done on the preliminary concept provided with solutions in all the three modules. Using these solutions the preliminary concept was refined. This concept is explained further in the figure 69. It consist of a hexagonal inner sheath and a circular outer sheath that sits over the length of the laparoscope. The tape is passed between these sheaths and is connected to the small and big spools. The trigger is connected to these spool wheels via a ratchet figure 70. The trigger aligns below the camera system. This concept is optimized further in the develop phase.



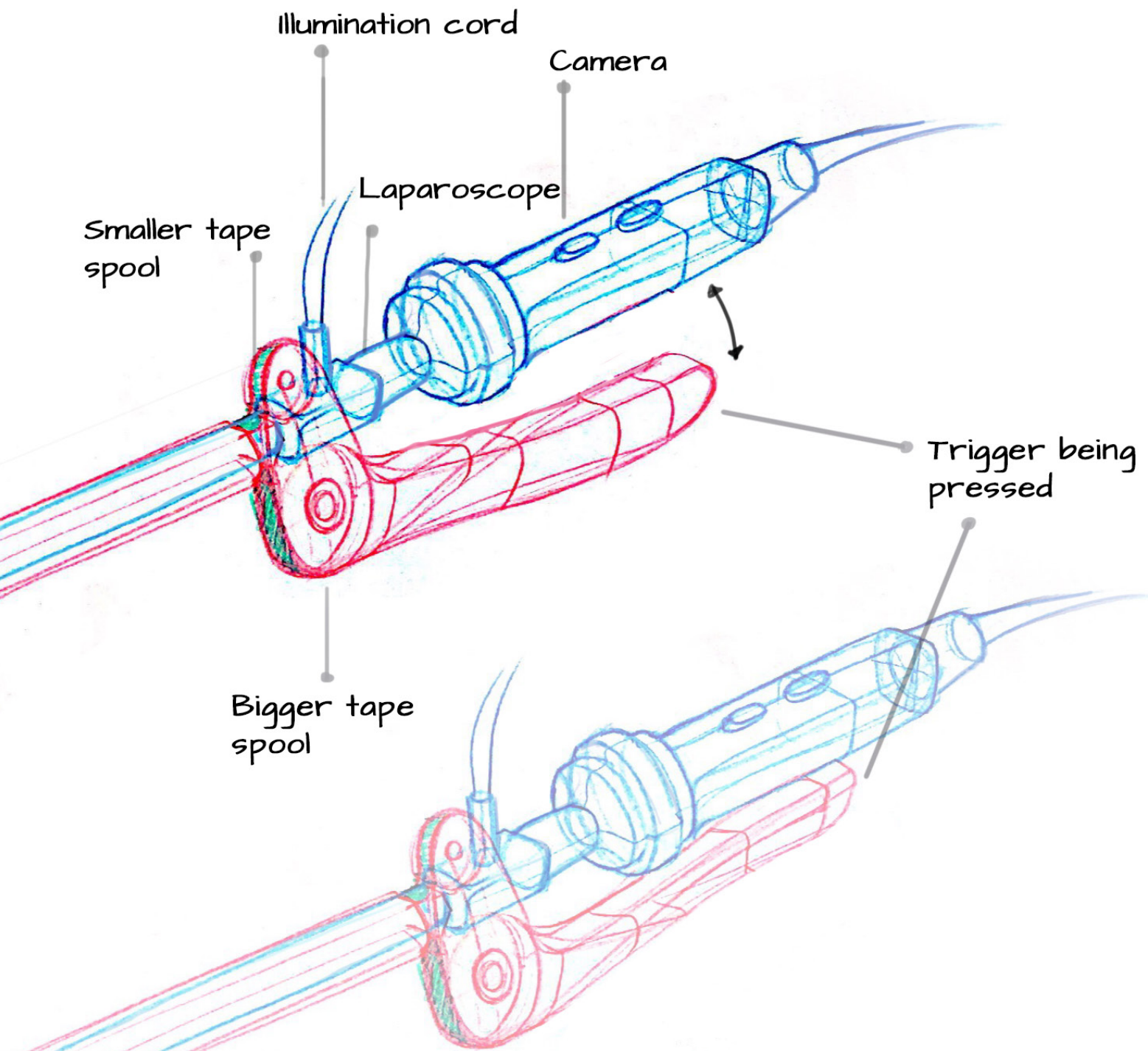

Fig. 69 Refined concept

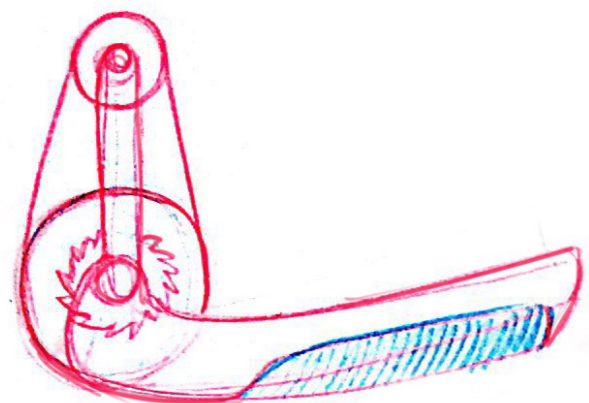

Fig. 70 Trigger connection via ratchet

DEVELOP







## The device tip

In this chapter, the process of the development of the tip and sheath design from the refined concept to a product proposal is explained. The development process involved, several rounds of sketching, prototyping, and testing. With every iteration, the design was evolved. During this process, critical tolerances and dimensions were taken into consideration. The chapter ends with a proposal of optimized device tip design.

9.1 Setting dimensions

9.2 Design development

9.3 The device tip proposal



## 9.1 Setting the dimensions

It is essential to learn the critical dimensions between the trocar and scope to ensure the passage of  $\text{CO}_2$  gas for insufflation, for degree of freedom for the surgeon and ease of movement of the scope within the trocar. For the development process a 0degree, 10 mm diameter Karl Storz laparoscope is considered due to its availability. It was learned that the trocar used with a 10 mm laparoscope had inner diameter of 11.53mm. Therefore the working area available to develop a solution is mere 1.53 mm (figure 71). This is a rather small dimension to work with. The current tip design has to be optimized to fit in this space and still allow some room for movement. This development process is elaborated in the next chapter.

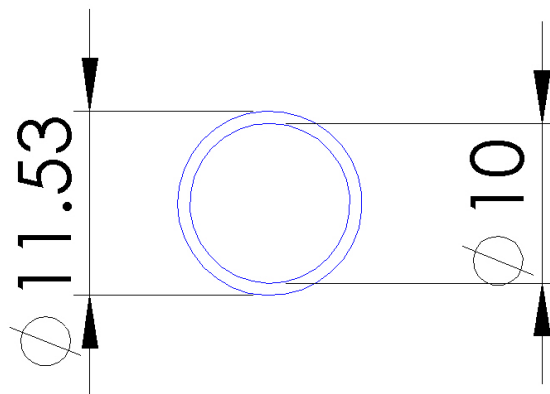

Fig. 71 Tolerance between the trocar and the scope

## 9.2 Design development

### Stage 1

It was learned that the tip and sheath design in the previous concept, though solved many concerns, it didn't work for the most important concern which was passing through the trocar and allowing the passage for insufflation gas. These two were the concerns of top priority. To solve this, the overall dimension of the tip and sheath had to reduce further. From the previous design, the most useful factor was the flat surface provided by the hexagonal sheath which helped to solve many issues of the moving of the tape. But it also added to the overall dimension. Taking the flat aspect of the hexagonal geometry, further ideation was carried out to reduce the dimensions (figure 72).

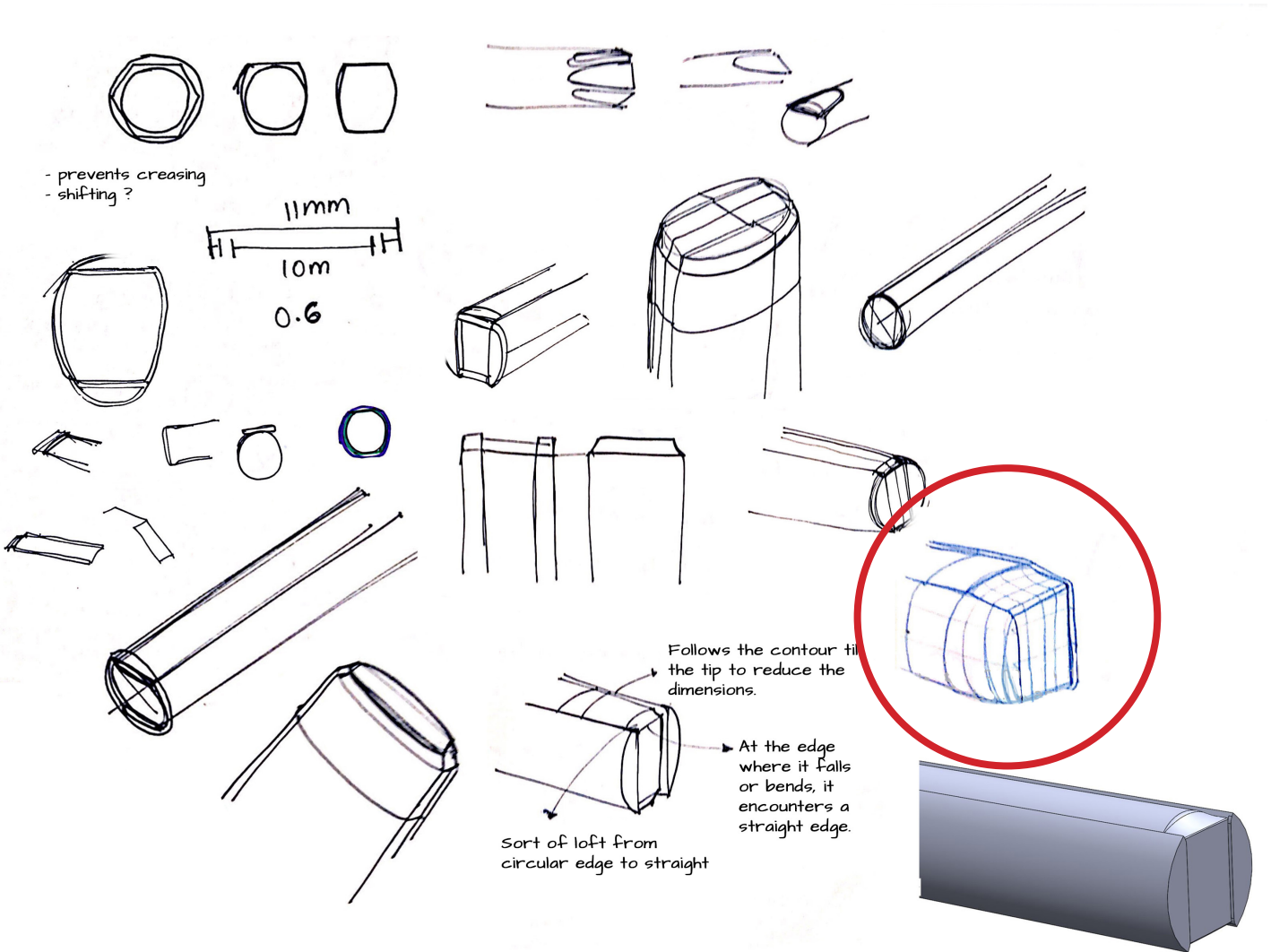

Fig. 72 Ideation on sheath design

The sketch in blue was the chosen design for the inner sheath. Instead of having a flat surface throughout the length of the sheath, the new sheath design just had a flat edge. This ensured that the tape passed over the flat face easily without creasing and also the overall dimensions of the sheath can be reduced in comparison to a hexagon. This was achieved by manipulating the geometry of that region from a circle to a square (fig. 80). Additionally, it had raised edges beside the tape to ensure the tape doesn't slip away and also guides it. To adapt to various configurations of the camera and light fibers in the scope, it was decided to have this inner sheath design in a transparent material. This would allow the light to pass as well as accommodate various placements of camera and light fibers in different scopes. The outer sheath is placed over this transparent sheath and this holds the tape in position while it moves.

This inner sheath with a new tip design and the outer sheath were built using 3D printing (figure 73).



Fig. 73 3D printed model.

To understand the behaviour of liquids with this new tip design and the tape, the 3D printed design was tested in a setup. The tests were conducted with water and fake blood. The detailed documentation of these tests and the setup can be found in appendix P. The 3D printed part was fixed on a stand at an angle to resemble its position in the inflated abdomen while operating, a piece of the tape was passed through it. Water and fake blood were applied on the flat face through a syringe and dropper (fig. 74). Upon soiling the tape was pulled at one end to reveal the fresh piece of tape on the surface. Through this testing, the behaviour of the liquid on the new tip design was studied. Videos were recorded in the process. It is to be noted that the tape used for this experiment had alternating absorbent and transparent patches.

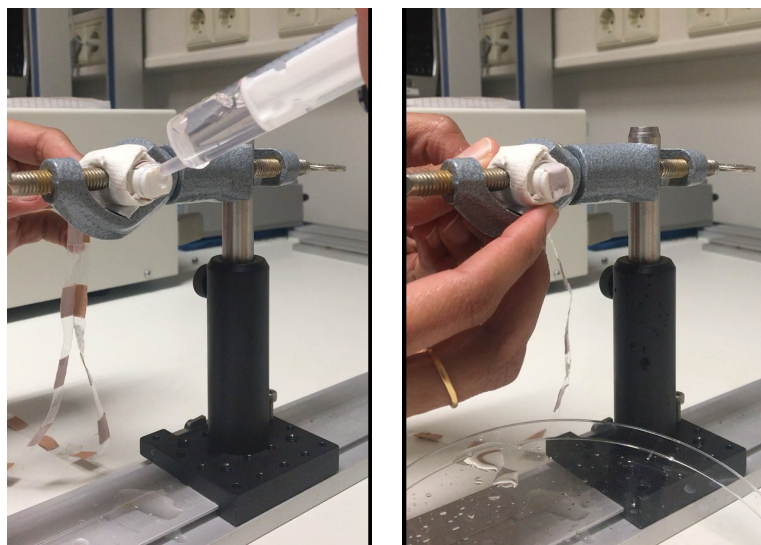

Fig. 74 Procedure of the tests.

This test showed that the tape passed as desired through the geometry of the inner sheath. However, few other problems related to the outer sheath were realized through this test. When the amount of liquid was more, small droplets cling to the bottom surface. They eventually fall off and little bits gets scrapped off on the edge of the outer sheath. This scrapping results in the droplet accumulating and clinging to the bottom edge of the sheath. Thus for the liquid to not gather near the edge of the tip, the outer sheath has to be a bit away from the edge. Other finding was, the top part of the sheath which had fresh tape, got dirty because of incoming liquid. Hence the fresh tape has to be covered before it reaches the flat face of the scope. The droplets on the flat face of the tip seeped through and got trapped between the tape and the surface. This was also because the microstructure of the layers of the 3D printed part allowed the liquid to pass through. **Here the hydrophobic material could help to not let the liquid spread.** The overall dimensions were still large by 1 mm to fit through the trocar and leave space for the air to pass. This was also because the design was 3D printed.

## Stage 2

Few design alterations were done to the outer sheath. The outer sheath was extended on the top to cover the fresh piece of the tape and protect it from the liquid. The bottom of the outer sheath was receded from the flat face of the tip because that would allow for bigger debris and liquids to fall off and not accumulate near the tip (fig. 75)

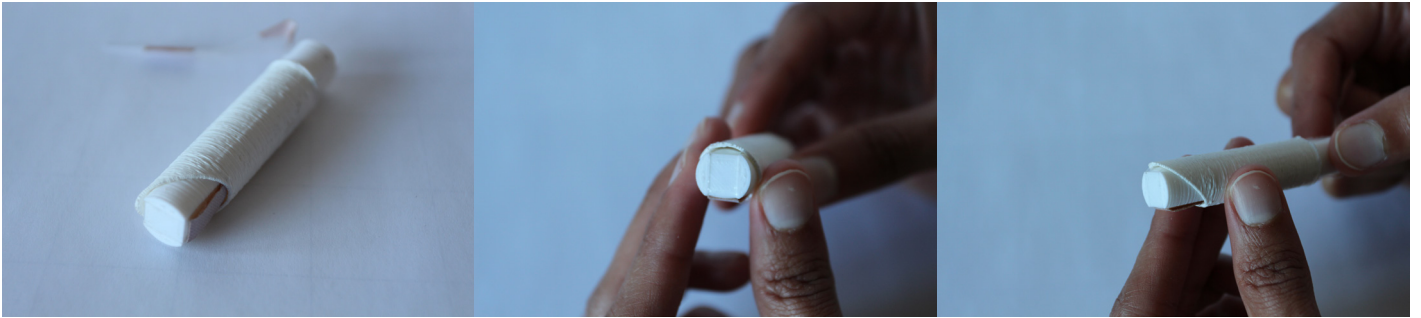

Fig. 75 Stage 2 iteration

**This gave an important insight for the mechanism, that the fresh tape should be on the top and the soiled tape should be on the bottom.** This will ensure that the fresh take doesn't get contaminated inside the sheath due to the soiled tape. **This, in turn, gives input for the interaction module. Since the soiled tape will be at the bottom, the trigger press action will wrap the soiled tape in.** The material of flat face of the inner sheath was hydrophobic. This will ensure that the liquid does not spread further and seep behind the tape to cause unwanted situation. Most of the tape related concerns were solved but yet the dimension was too large for the trocar.

## Stage 3

To reduce the overall dimensions, the key was to lose the outer sheath as that added to the dimensions. For this, the obturator in the trocar was studied (figure 76).



Obturator

Fig. 76 The trocar and the obturator inside the trocar ("Bladeless Optical Trocars Market will touch a new level in upcoming year - Key Players involved in the research like Medtronic, Johnson and Johnson, Cooper, Conmed, B. Braun, Teleflex - Industry Chronicles," n.d.)

The obturator has a thin metal sheath with a transparent head. The scope is placed inside the obturator and then they are together inserted in the trocar. This is used when they are entering the inflated stomach for the first time. The transparent part of the obturator allows the scope to see whether the penetration is happening correctly or not. The obturator has the perfect dimensions which the device can adapt, to fit in the critical tolerances. . The material of the obturator was stainless steel. The thinness achieved by the metal allowed the obturator to pass freely in the trocar. Hence it was decided to adapt to those dimensions and material for the inner sheath design. By having a metal inner sheath, keeping the tape in place unlike the plastic sheath through guides was not possible. Therefore, a new way to keep the tape in place needed to be ideated (figure 77)

Various configurations of slots in metal tube to pass the tape and keep it in place.

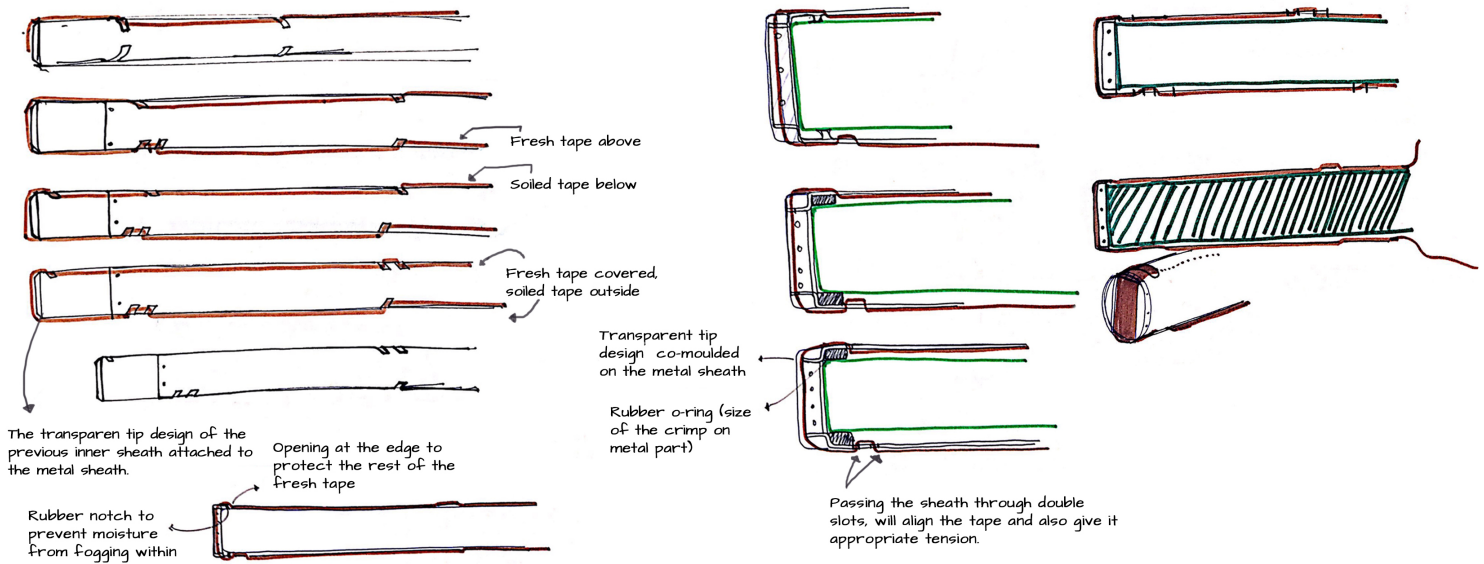

Fig. 77 Ideation on ways to keep the tape in place in the metal sheath.

By having slots in the metal tube at the appropriate place, the tape can be passed through the sheath easily and also tension can be maintained. From the ideation, one configuration was chosen and a detailed CAD model was made. This is explained further using a cross section view. (figure 78). The transparent tip design of the previous inner sheath was incorporated in the metal sheath the same way as the transparent part is joined to the metal tube in an obturator which is the co-moulding process (figure 79).

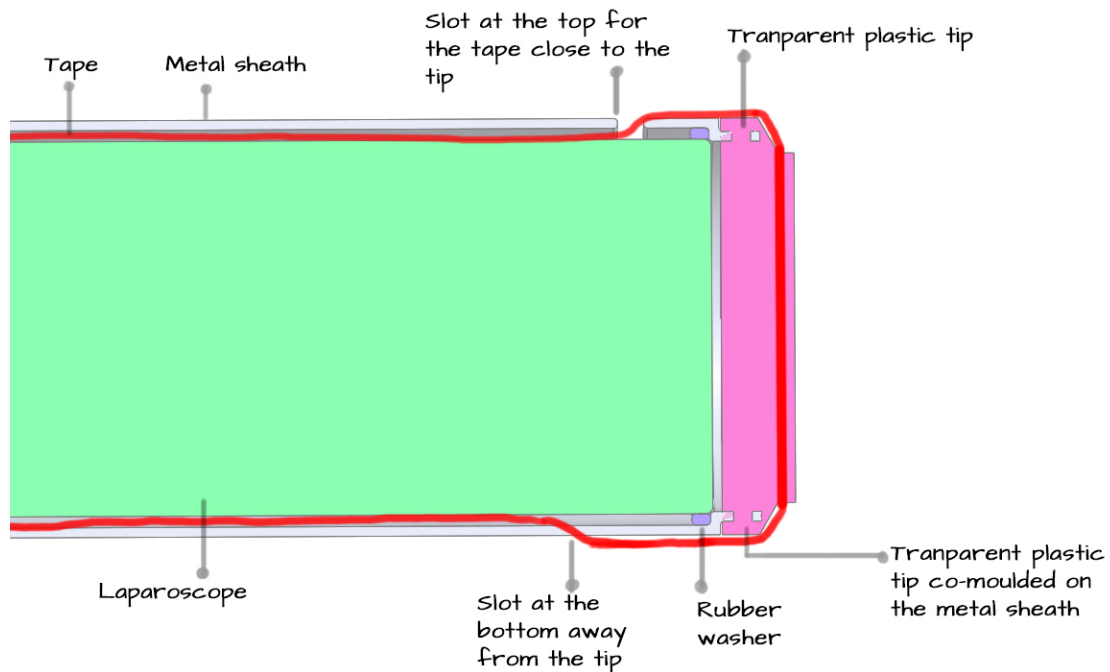

Fig.78 Cross section view of the stage 3 iteration

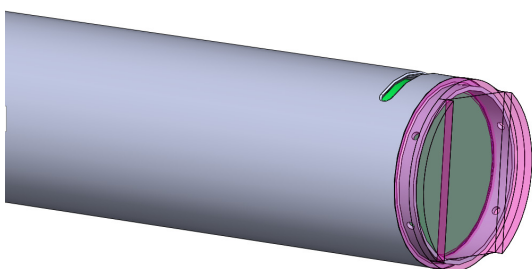

Fig. 79 Transparent tip design joined to the metal sheath

A mockup was created using the metal tube of the obturator and transparent acrylic sheet (fig. 80). The circular acrylic disc was sanded to create the same geometry at the edge (figure 80A). Hydrophobic material will be applied on the flat face on the sides to create a guide for the tape on the flat surface and also helps to stop liquid from spreading. In this mockup a transparent plastic sheet is used to create this guide (figure 80B). The tape passed over the flat surface through the geometry built without creasing (figure 80C). Slots were made on the metal tube for the tape to pass and also to give it tension (figure 80D).

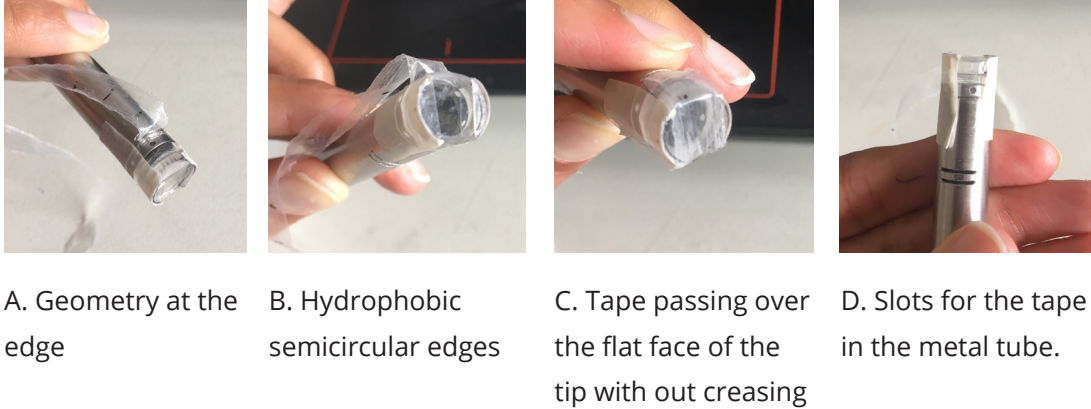

Fig. 80 Mock up using metal tupe from the obtruator and acrylic sheet

## Stage 4

The design of the device tip at this point had just a single metal sheath with a transparent tip with hydrophobic surface. These designed addressed all the concerns. However, by building the prototype, it was realized that passing the tape from the metals slots was a very time consuming process . This would result in a difficult assembly during manufacturing of the device. The structure of this sheath was modified a bit to ease the assembly process. This design is shown in figure 81.

The tranparent plastic tip was extended and the tape was passed through the plastic part instead of metal part. The metal tube just served as a passage for the tape from the tip to the spool. Plastic material gave the flexibility of having the same kind of slots which the metal sheath had while also having a guide for it inside the tube. The slots were inclined to protect the tape from incoming liquids and also to guide it from inside to outside. In this design, both the slots have been placed at the same distance from the tip unlike the previous iteration where the bottm slot was way. This was again done for easing the manufacturing process. The raised edges on the flat face of the tip were extended also to the curved surface. This ensured that the tape is guided right from the moment it left the slot. Besides having raised edges also protected the tape incase of accidently touching any tissue during the surgery. A rubber washer/o-ring is moulded in the plastic itself during the injection moulding. This rubber structure will prevent moisture to get trapped between the scope and the transparent tip.



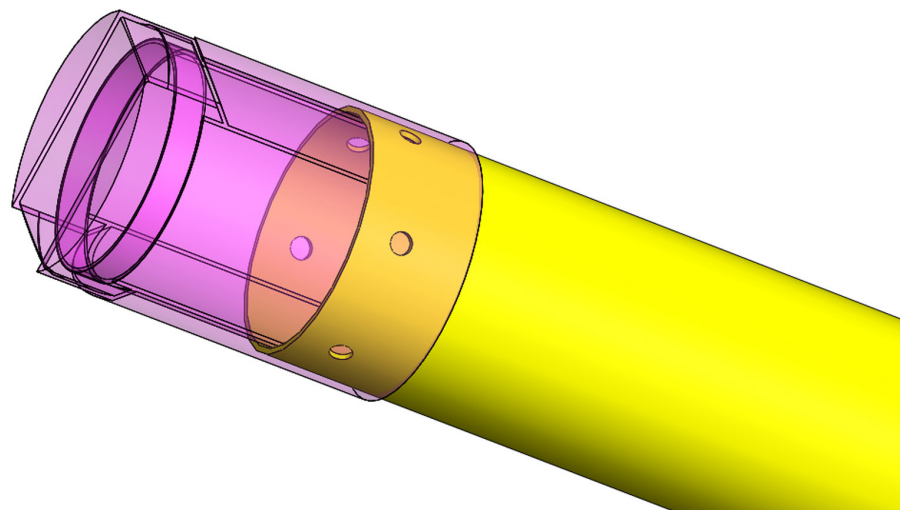
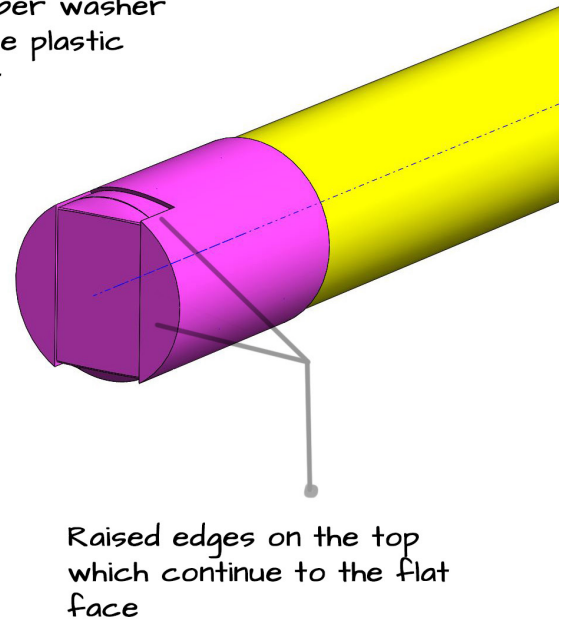
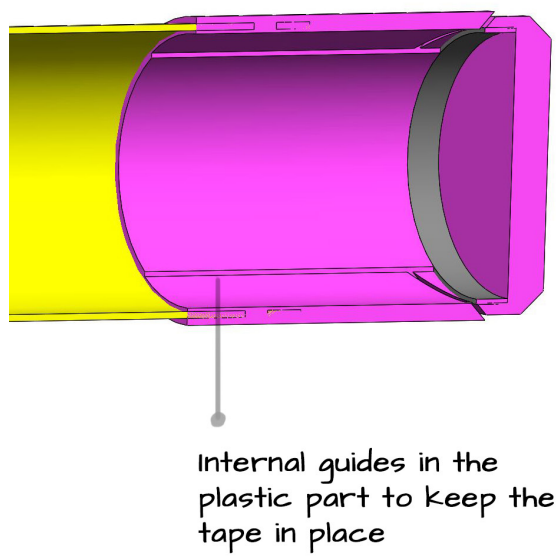
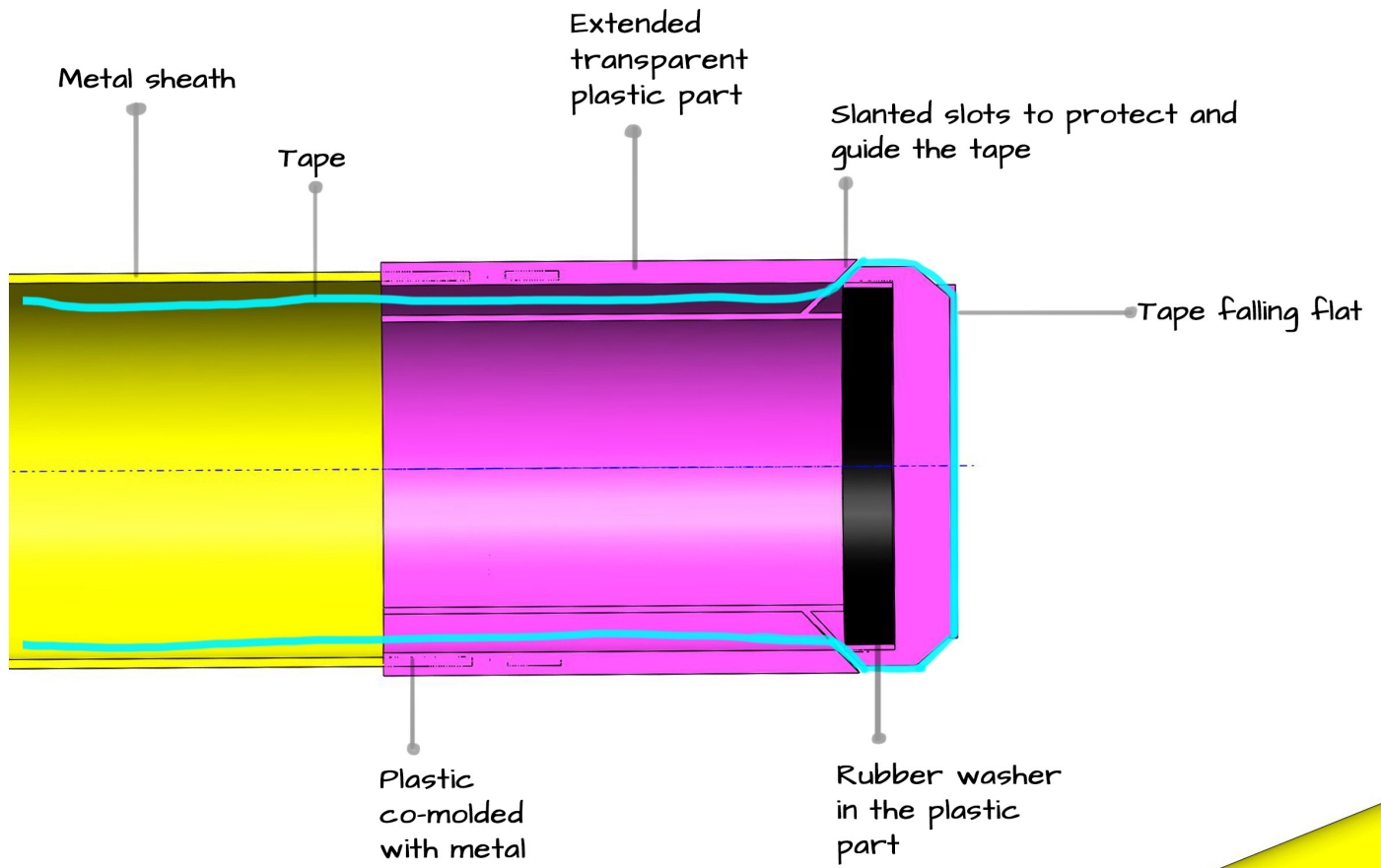
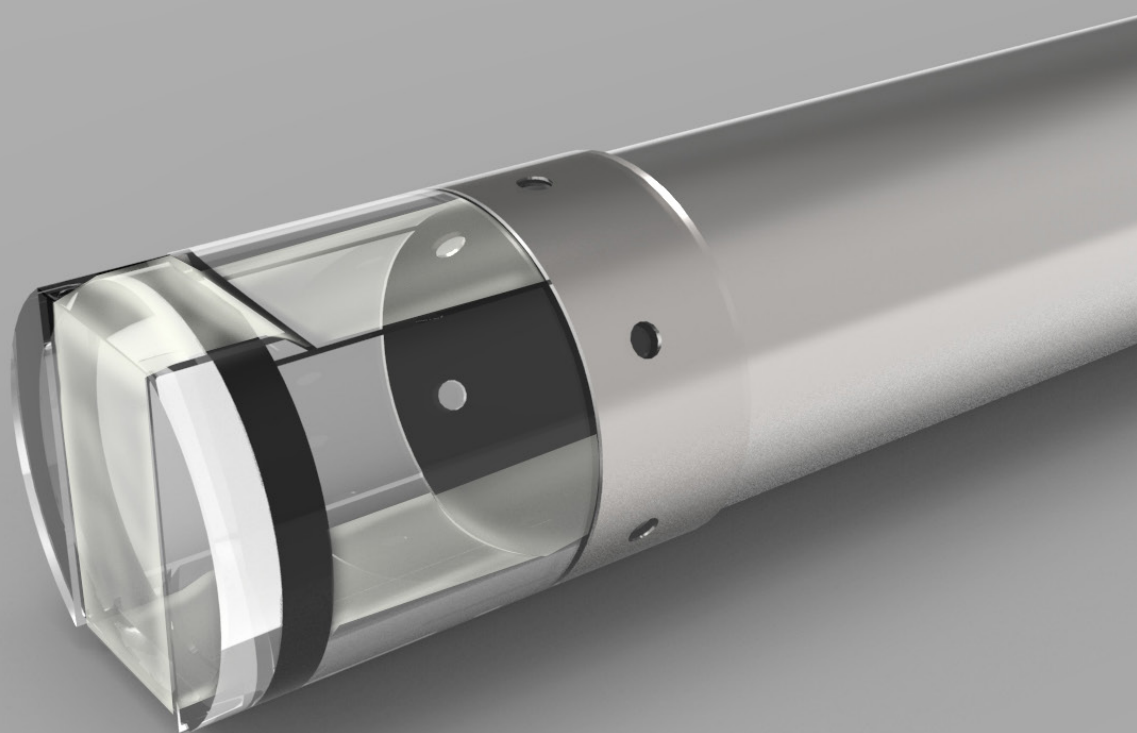
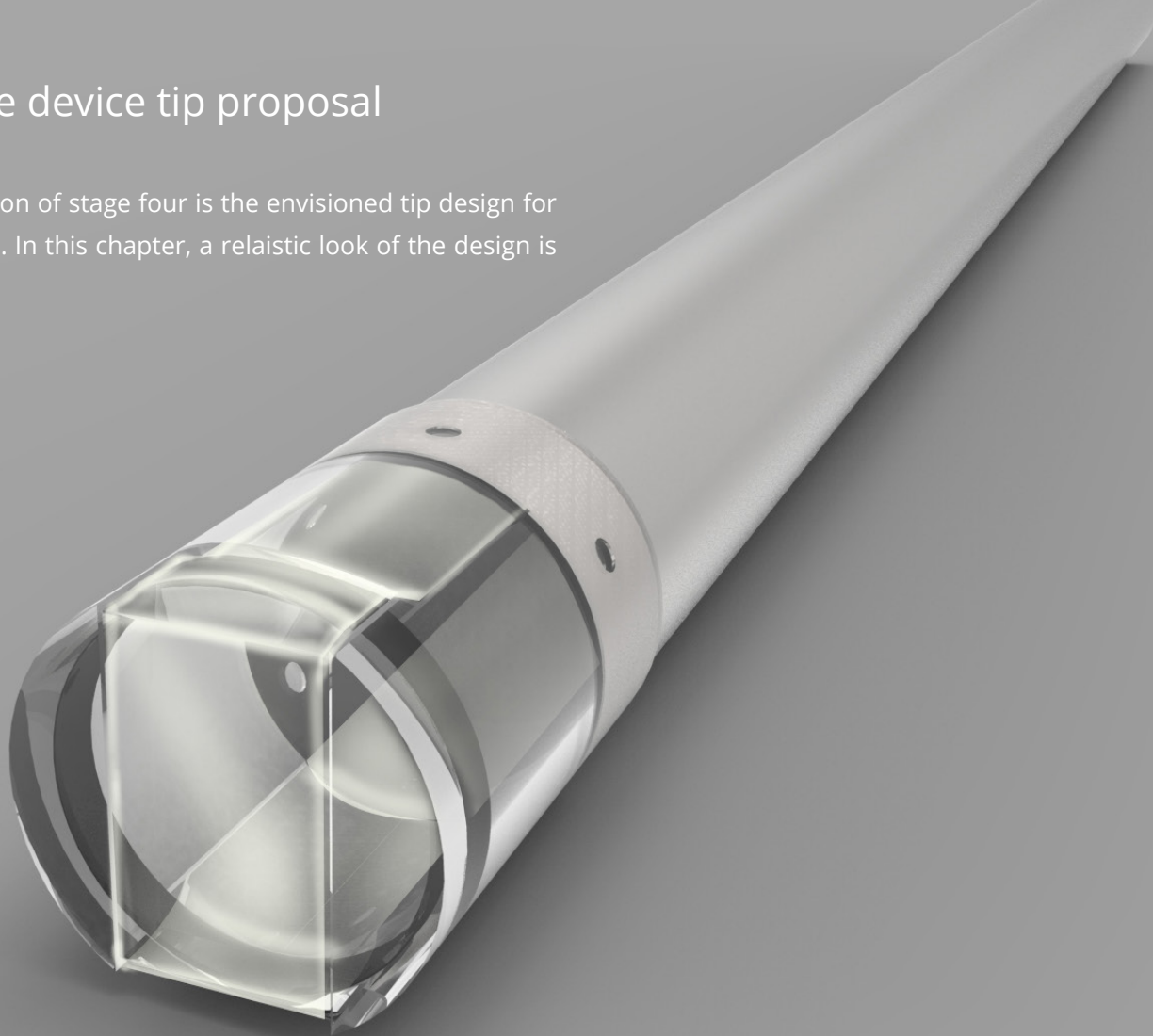
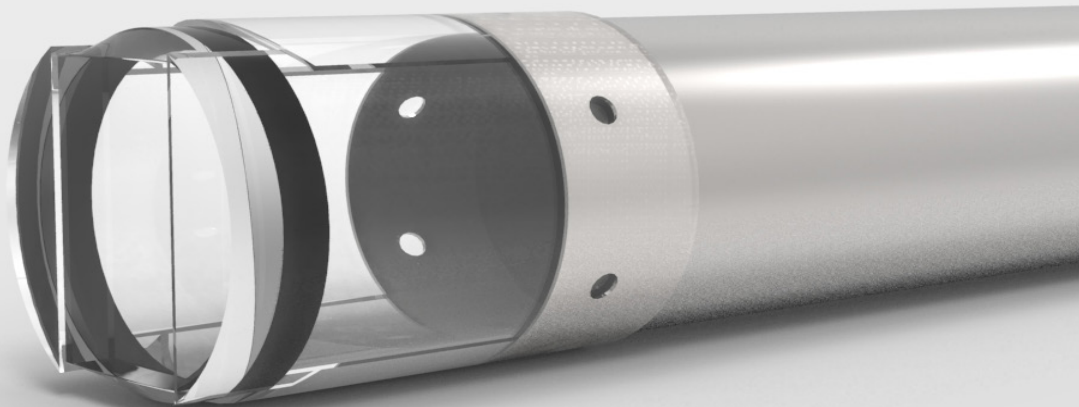
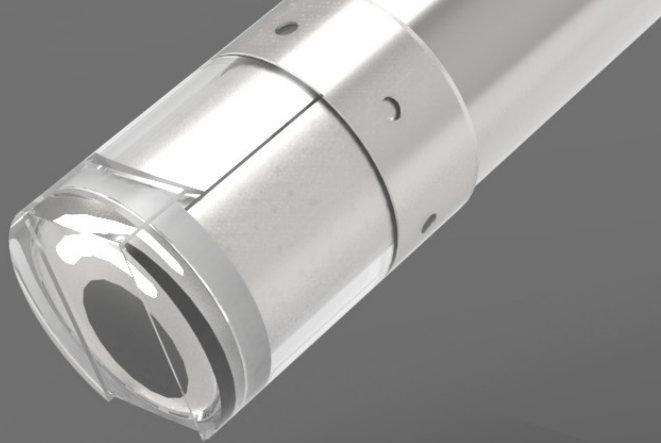

Fig. 81 Stage 4 iteration

### 9.3 The device tip proposal

The iteration of stage four is the envisioned tip design for the device. In this chapter, a realistic look of the design is shown.





# 10



## The device interaction

In this chapter, developments of the interaction of the device are elaborated. The key decisions which influenced the design of the trigger are discussed. Foam models and CAD designs were created to understand the form and its effect. These mockups were tested with the setup already created for ideation sessions. This chapter concludes by providing an interaction proposal.

10.1 Design development

10.2 Position of the trigger

10.3 The device interaction proposal



## 10.1 Design and development

Following the inspiration of the bicycle brakes, various forms of the trigger design were ideated. Foam models of these forms were created. These triggers were fixed on the scope with a pivot on a foam block. The feeling of pressing the trigger was created by attaching springs to the trigger and the foam block (figure 82).



Fig. 82 Foam models of trigger designs

Each of the triggers were tried and acted out by using various holding styles from the collage. These collages can be found in appendix Q. The findings from each trigger trial were noted down and build upon to create the next trigger design, till a satisfactory output was achieved. The analysis of the triggers can be found in appendix (fig. 94). Important insight from these trials was that the trigger should be in the same axis as the physical form factor. of the laparoscope and camera system. Hence parallel to the shaft. This will make the trigger easy to reach. Further a curve towards the end of the trigger would allow for fingers to be anchored while pressing the trigger (figure 83). These findings were incorporated in the new trigger design (figure 84). This trigger was possible to operate with most hand postures tried from the developed collages (figure 85).

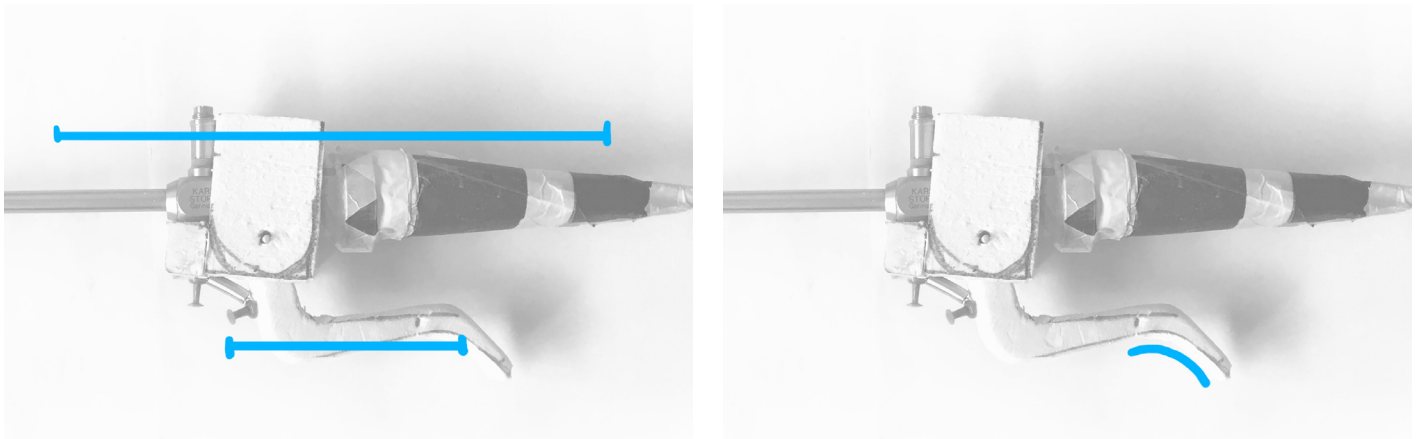

Fig. 83 Parallel to the shaft (left), curve to anchor the fingers (right)

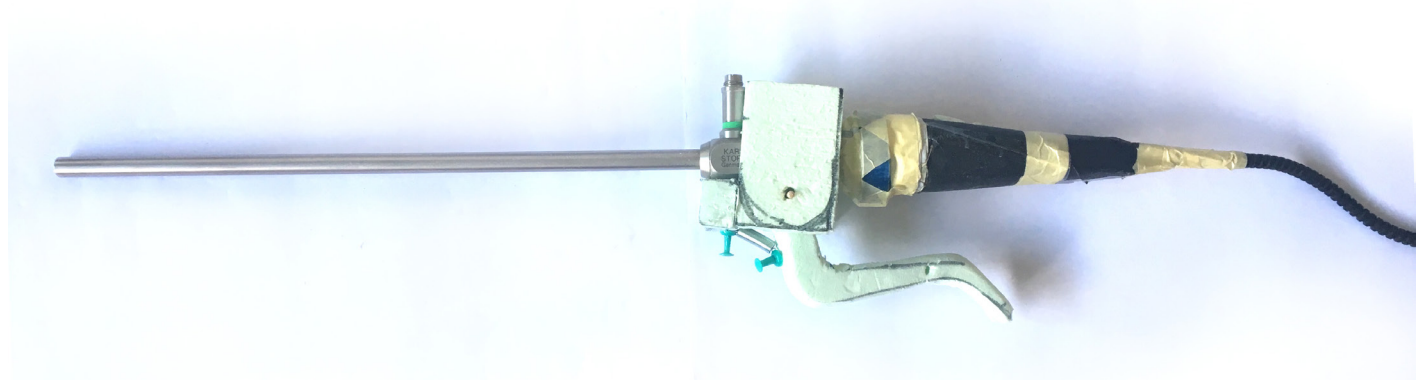

Fig. 84 Foam models of trigger designs

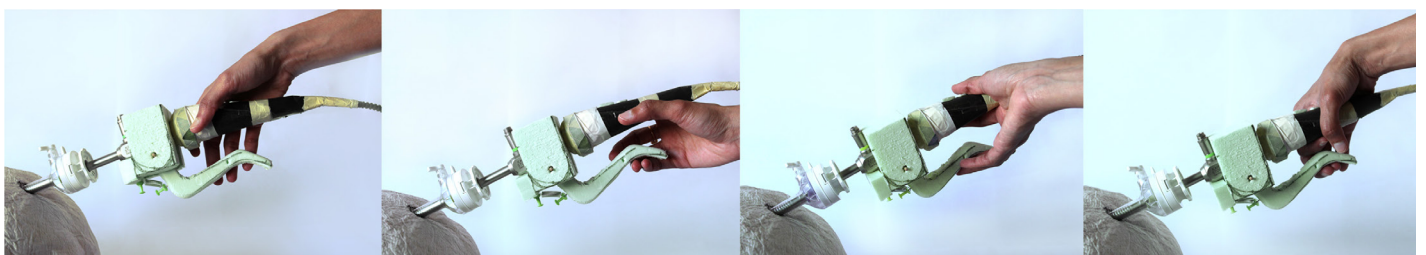

Fig. 85 Different holding styles tried with the new trigger design.

This trigger was tested at Pontes Medical. Following remarks were noted down:

- The trigger should be bit smaller in size and a bit closer to the main body of the scope.
- For initiating the trigger action, the scope will have to be still held with the same hand. Thus considering the power grip which is the most common grip, the thumb, and the index finger might hold the scope with the rest of the fingers available to pull the trigger. So the trigger should also allow for other non-dominant fingers to anchor on it while pulling such as the ring and the pinky finger. These two fingers generally follow the same motion in the power grip and have a more static function (Matern & Waller, 1999).

These two insights were then incorporated into the trigger design.

## 10.2 Position of the trigger

Once the form of the trigger was decided, it was essential to finalise its position with respect to the scope and mechanism. This will optimise the trigger design for fitting in the device together with other modules.

A few conclusions from previous chapters have to be considered for this. From the iterations of the tip design in the chapter 9.2, it was found that the trigger press will pull the soiled tape in. From the chapter 4.2, where the ergonomics of the laparoscope was studied, it was found that the trigger has to be closer to the camera module to be well in reach to operate. From the mechanism exploration in chapter 7.4, it is clear that the trigger moves the ratchet mechanism.

Now, considering the Karl Storz scope, it has a light cord attachment on the shaft. Unlike the laparoscope from Olympus, the Endoeye, where there is no light cord and the form factor is straight. The device to be compatible to these major scope manufacturers as it is a requirement stated in chapter 6.2.

So for the trigger to be close to the camera module and also adapt to both these scopes, either the whole ratchet system will have to be shifted towards the camera module or the trigger design has to be extendable to reach the camera module.

This has implication on the mechanism. The tape has to be wrapped back easily. The tape and ratchet will have the same axis. Ideation was done on both the options stated earlier to see feasible possibilities. These sketches are shown in figures 86 and 87. They are discussed thereafter and a choice is made.

Extending the body:  
Still has to rely on the  
geometry

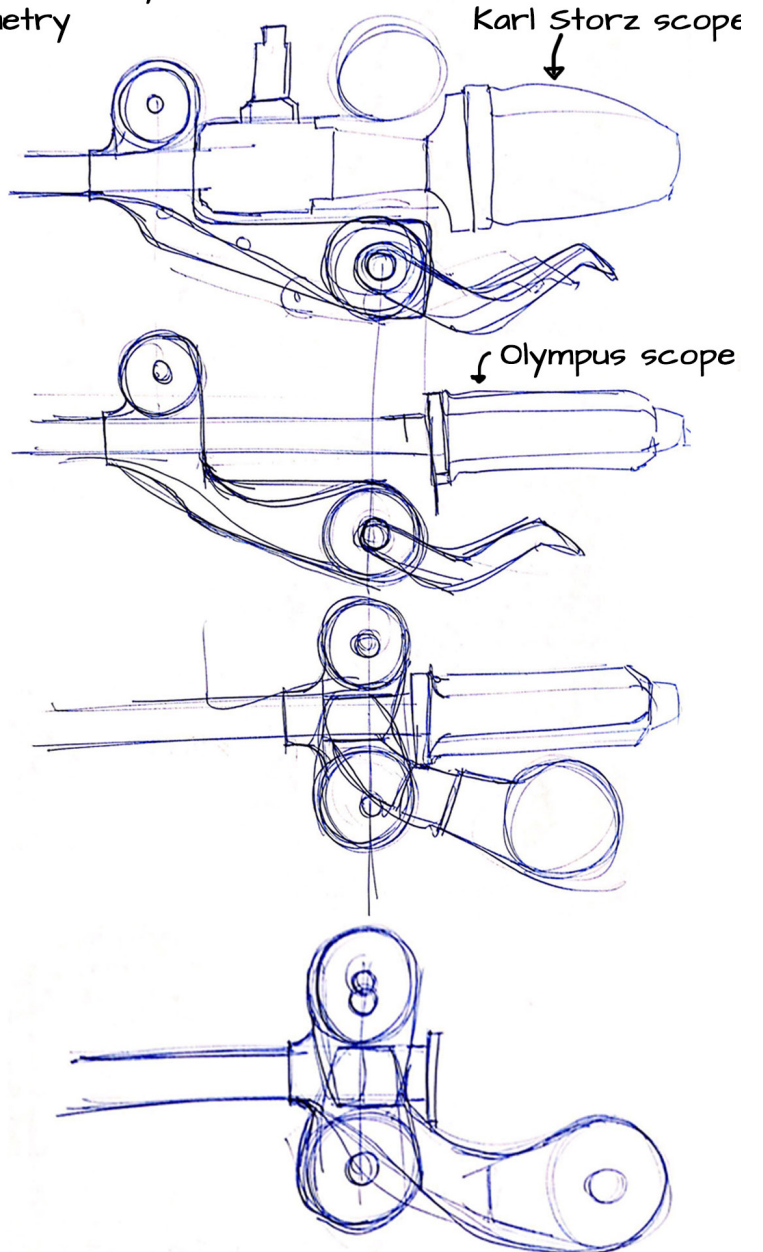
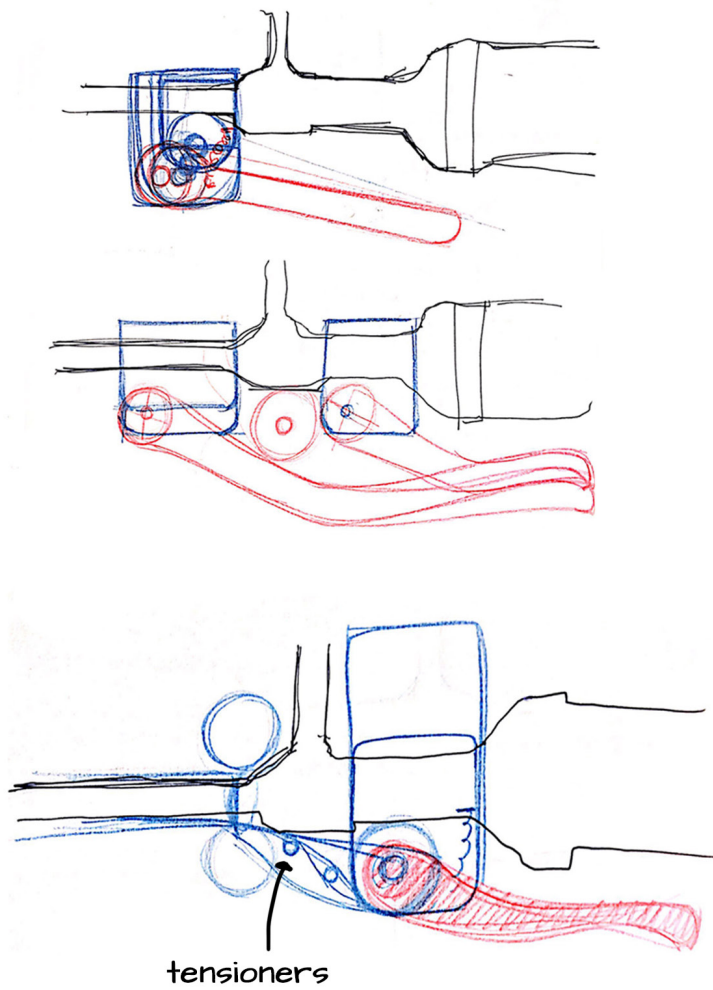

Fig. 86 Ideation for shifting the mechanism next to the camera

Shifting the mechanism next to the camera:

The tape from the sheath has to be guided and tension has to be maintained if the mechanism is shifted closer to the camera module. By having tensioners at the appropriate position, this can be achieved. In the above sketches, both the scopes with and without light module has been considered. It was learned that by shifting the mechanism and thus the the trigger backwards close to the camera, the design of the device has to still rely on the geometry of the scope in this case the structure of the light module. This is also one of the findings in chapter 4.3, where ecosystem of the laparoscope is studied. The device has to be independant of geometries and dimensions. So if the trigger has to be within reach, if the device has to be compatible to all major scopes and be independant of geometries, then this option does not fit into the criteria.



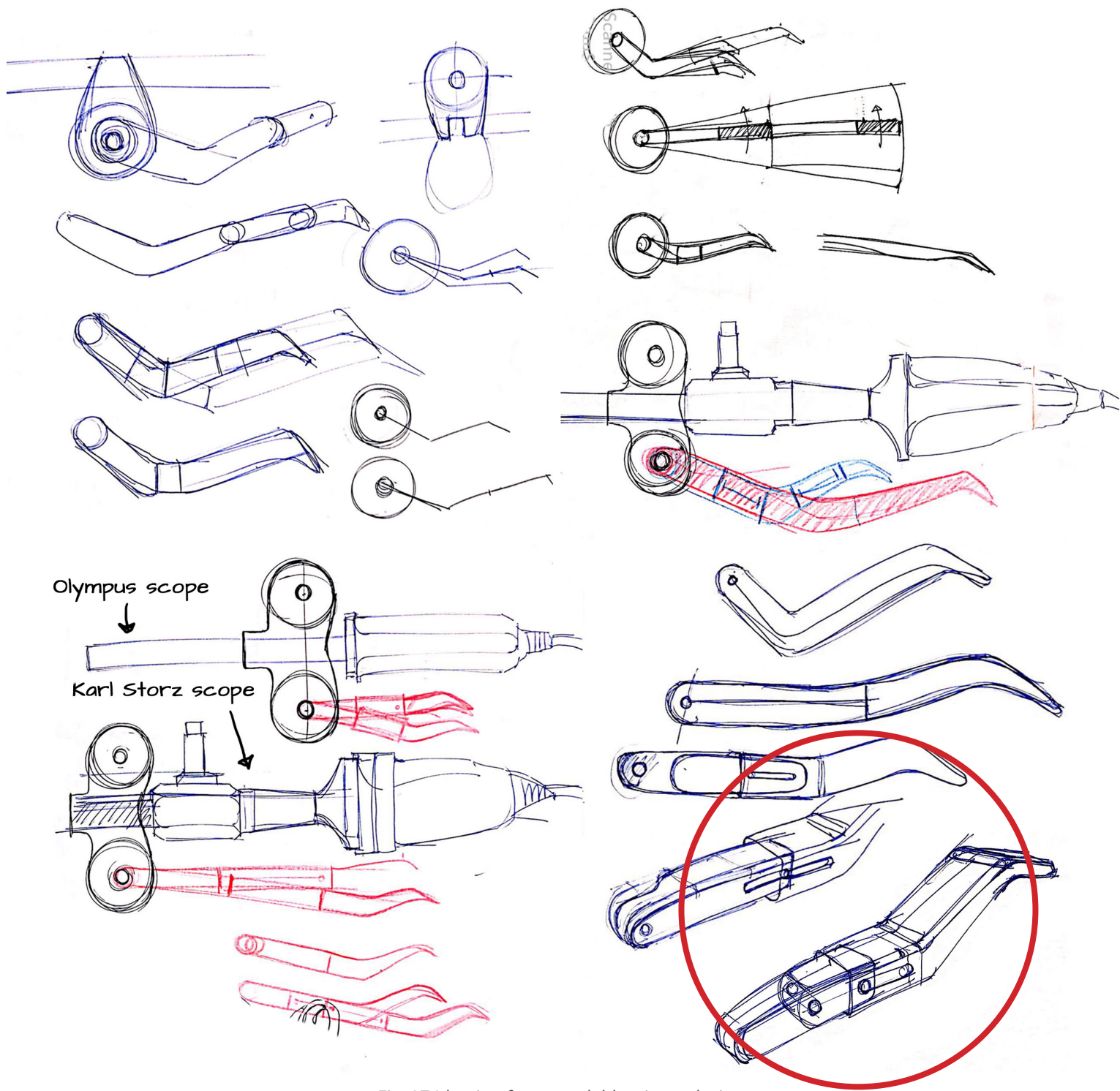

Fig. 87 Ideation for extendable trigger design

### Extendable trigger

Extending the trigger to the desired position depending on the scope and the surgeon's need seems like a feasible solution. This allows the tape wheel and ratchet wheels in the mechanism to be in the same line, making it easier for the tape to be wrapped back. The form factor of the trigger decided previously will have to be redesigned to allow extending it.

## 10.3 The device interaction proposal

The form of the trigger developed in chapter 10.1 and the idea of extendable trigger were combined to form the interaction of the envisioned solution. In this chapter this proposal of the interaction is showcased.

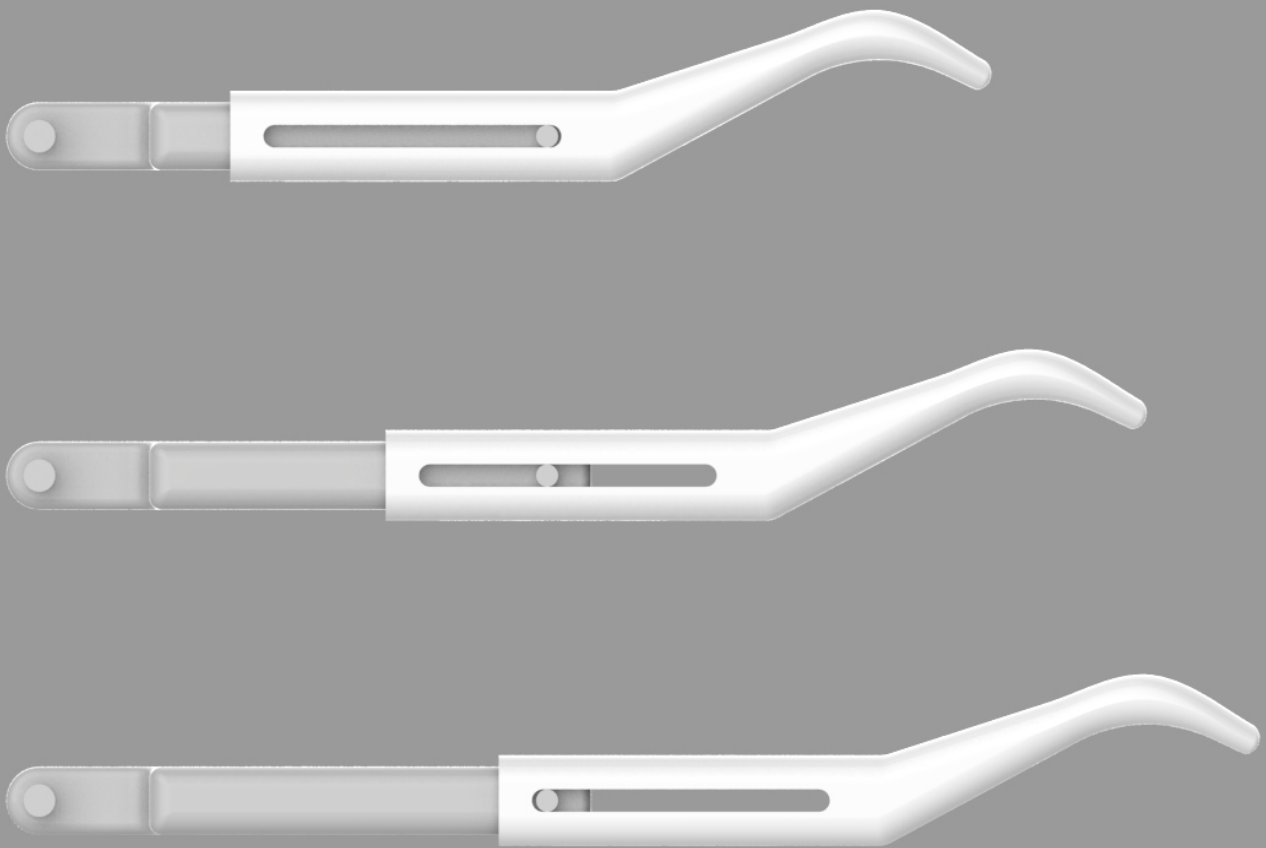

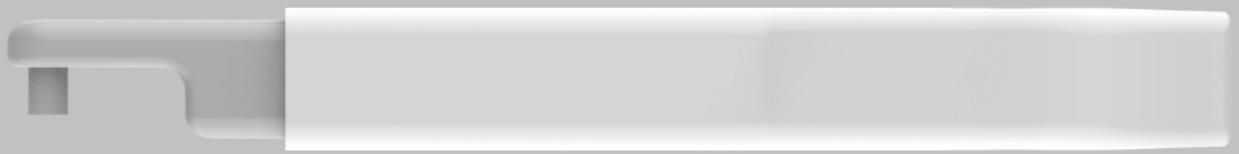
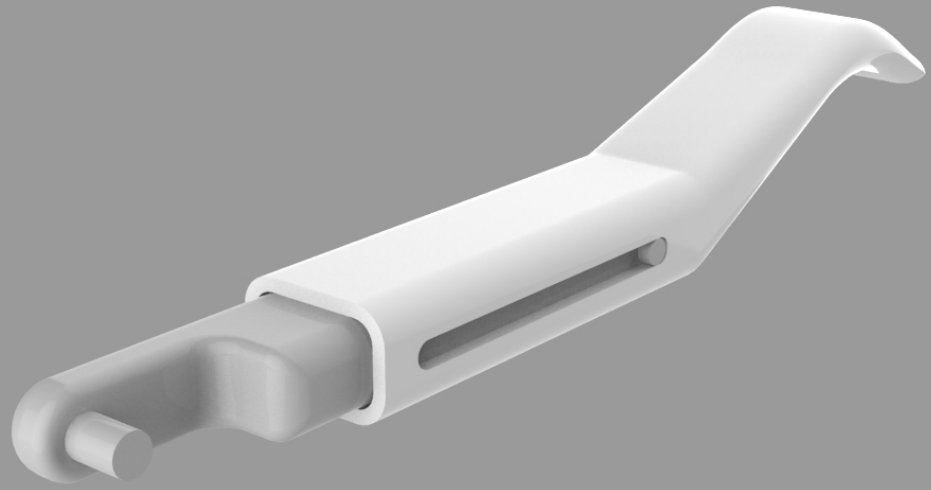



## The mechanism

To support the interaction of the device and to enable the movement of the tape, a supporting mechanism was needed. This chapter documents the process of developing the mechanism. Initially the working principle is defined. Thereafter, the factors affecting the size of the system are described. Based on these, configurations of mechanism are ideated. The chapter concludes with a proposal for the mechanical system.

### 11.1 The working principle

### 11.2 Setting the dimensions

### 11.3 Design development

### 11.4 The mechanism proposal

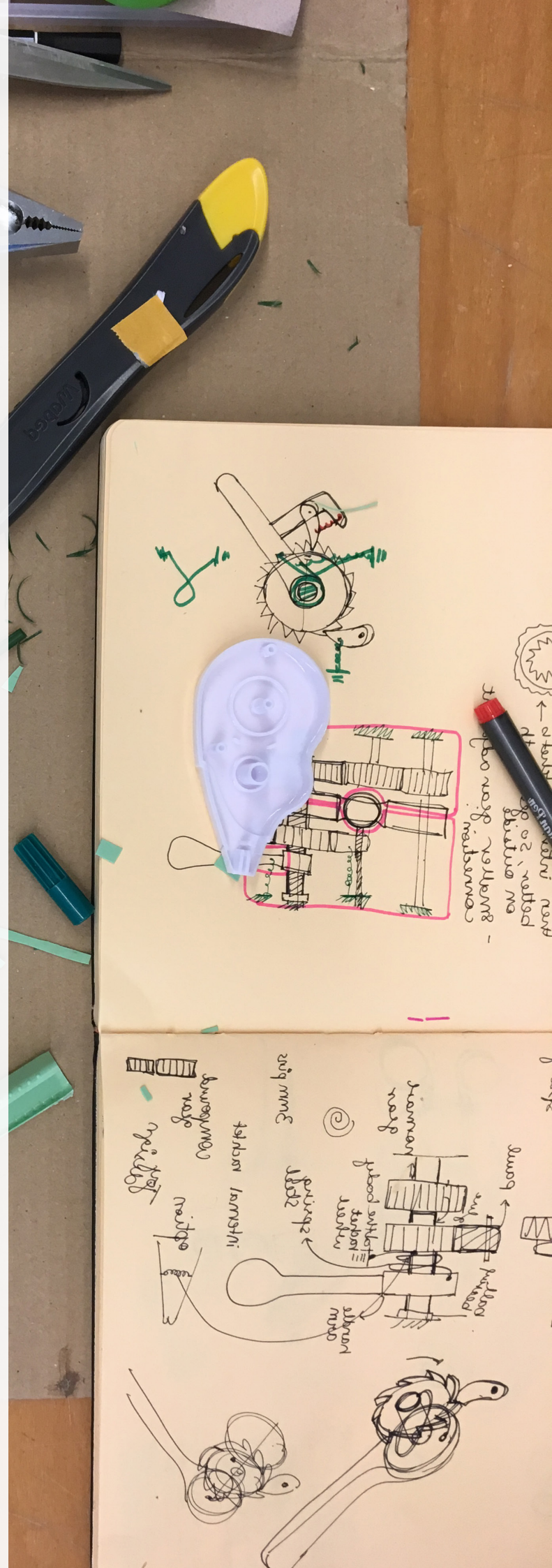

## 11.1 The working principle

By learning the mechanical system of the correcting tape, it was understood that defining the basic mechanical requirements of a system would be the first step to building it. It has been established in the chapter 9.2 that the spool for the soiled tape will be at the bottom and the fresh tape will be at the top. Thus, the pull of trigger takes back in the soiled tape. To create this action, the trigger pull has to create a rotational motion of the wheel in one direction where the tape is being wound (figure 88)

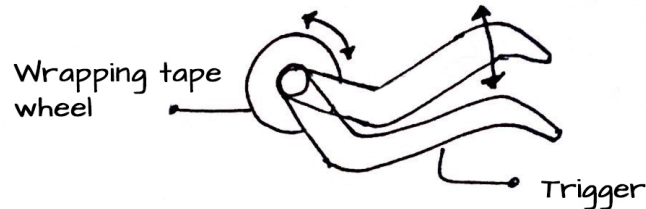

Fig. 88

Along with this the rotational motion, it has to be made sure that, the wheel does not rotate in another direction, as this might result in the tape to unwind. This suggests a need for ratchet mechanism on the axis of the wrapping tape wheel. The moving pawl of the ratchet will be attached to an arm. This pawl will allow the wrapping tape wheel to move. In this case, the arm is the trigger of the device (figure 89). The trigger has to come back to its position after one press to be ready for the next press. Hence the trigger will be under spring force and free moving on the axle. The stopping pawl is required to stop the motion of the ratchet in another direction.

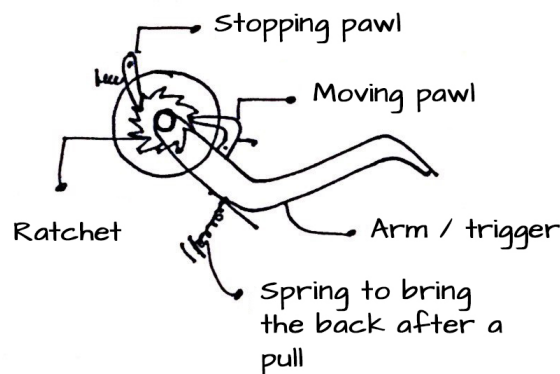

Fig. 89

Along with the motion of the wrapping wheel at the bottom, the wheel with the fresh tape situated above the scope has to rotate equally and at the same time. This can be done in many ways such as via gear transmission from the bottom ratchet to the top or creating tension-based movement. The top wheel also needs to rotate in one direction. Thus a stopper in another direction like a spring or ratchet is required at the top (figure 90).

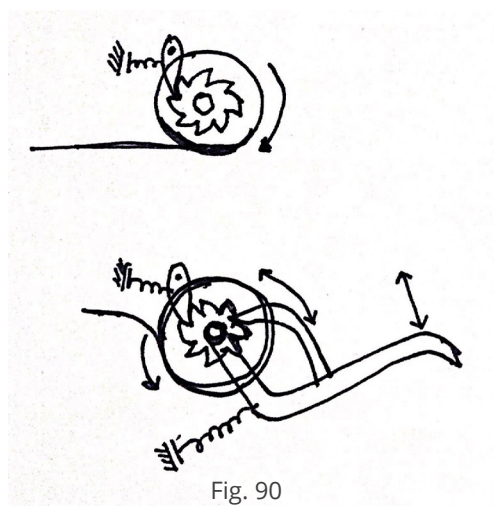

Fig. 90

The tape passing through both the spools has to be under appropriate tension to not buckle at any point but yet move efficiently (figure 91). Thus the tape has to allow for this linear tension.



Fig. 91

To summarize, the pull of the trigger has to result in rotatory motion only in one direction leading to linear displacement of the tape. Many mechanical ways could be proposed to achieve this underlying principle. The one proposed above is one of the ways.

## 11.2 Setting the dimensions

The size of the system is a crucial and it depends on a number of factors. In order to define these influencing factors, basic calculations were carried out.

Starting from the wheel which wraps the soiled tape which will be rotated by the trigger, Considering the circumference  $c$  of the wheel,  $c=2\pi r$  ;  $r$  mm is the radius of the wheel ;  $2\pi= 360^\circ$  (figure 92)

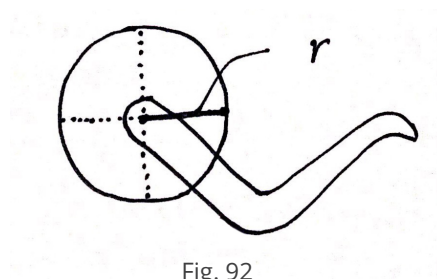

Fig. 92

Therefore, length  $l$  mm of the tape patch which will be wrapped on wheel with every trigger press will be

$$l = \theta \times \frac{\pi}{180} \times r$$

Where  $\theta$  is the angle of rotation of the wheel done by the trigger (figure 93)

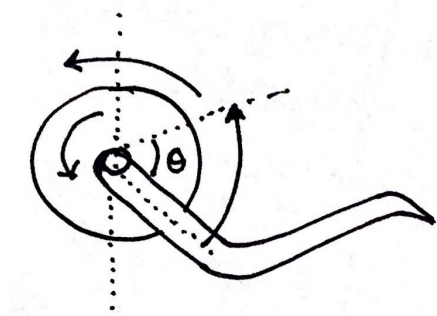

Fig. 93

$$\theta \times \frac{\pi}{180} = \text{constant, as it is the user input and will be same with every press of the trigger}$$

$r$  = the radius of the wheel which will keep increasing after every rotation as the tape gets wrapped  
Therefore,  $l$  = the length of the tape patch will also go on increasing with every rotation.

Defining these variables in context of the device

$\theta$  is the angle of rotation of the wheel

It's essential to define the angle of rotation done by the pulling of the trigger by the user. With the chosen trigger design from the interaction module, few angles of rotation were experimented. While trying, it was kept in mind that the user will have to make minimum and easy movements while holding the scope steady. So the action should occur with a pull requiring less force and not much displacement. From the tests, 20 degrees of movement by the user would be comfortable to carry out and also possible with the geometry of the trigger.

$l$  = the length of the tape patch

Length  $l$  of the tape patch can be minimum equal to the length at the tip (figure 94). Less than this length would not provide a clean surface in one trigger press.

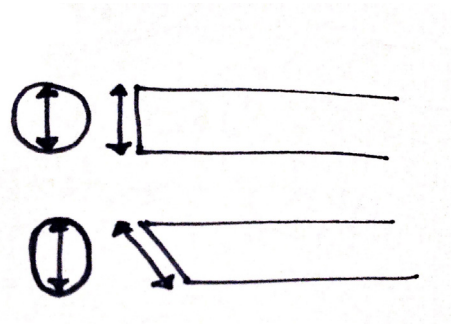

Fig. 94

This length is different for different angles of the scope and also for different diameters of the scope.

Considering, a 10mm, 0-degree scope, the length  $l$  of the tape patch will start from 10mm. This value will keep on increasing, thus the length of the patches of the tape will have to gradually increase after every rotation to match this change.

Substituting the value of  $\theta$  and  $l$  in the formula (1), radius  $r$  of the wrapping wheel comes to around 28 cm thus the diameter will be 46mm. This is a rather big dimension to be incorporated into the design considering the available space on the scope.

In conclusion, for the decided configuration, approximate 20 degrees of angular movement with the trigger will be done by the user. In order to reduce the size of the wheel system, gear transmission will have to be incorporated such that it transfers the 20-degree movement input to the required rotational output of the small wheel to wrap the soiled tape. This will help in reducing overall size.

This mechanical system can be the same for a certain scope diameter and with different angles within that diameter. Only the length of tape patches keep changing to accommodate different scope sizes.

## 11.3 Design development

From the working principle and the size calculations, basic idea of the mechanical system was gained. Based on this basic idea, possible configurations of the system were sketched out. During the sketching of the mechanical components, the casing and embody of the device was also thought along. A simple 3D printed set up (figure 95) was developed to create a better understanding and the configurations were ideated around this with the aim to make the system simple and compact (figure 96)

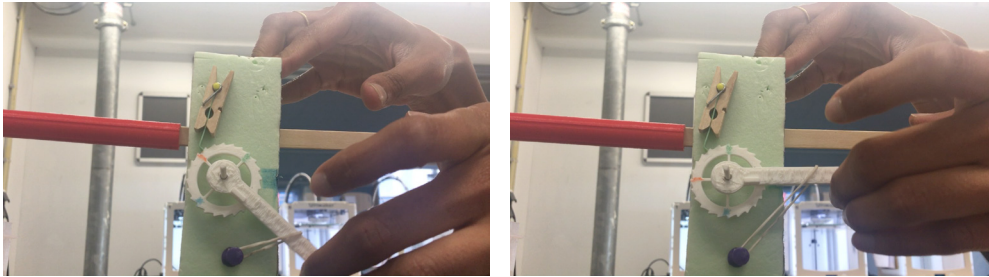

Fig. 95 3D printed setup of the mechanism.

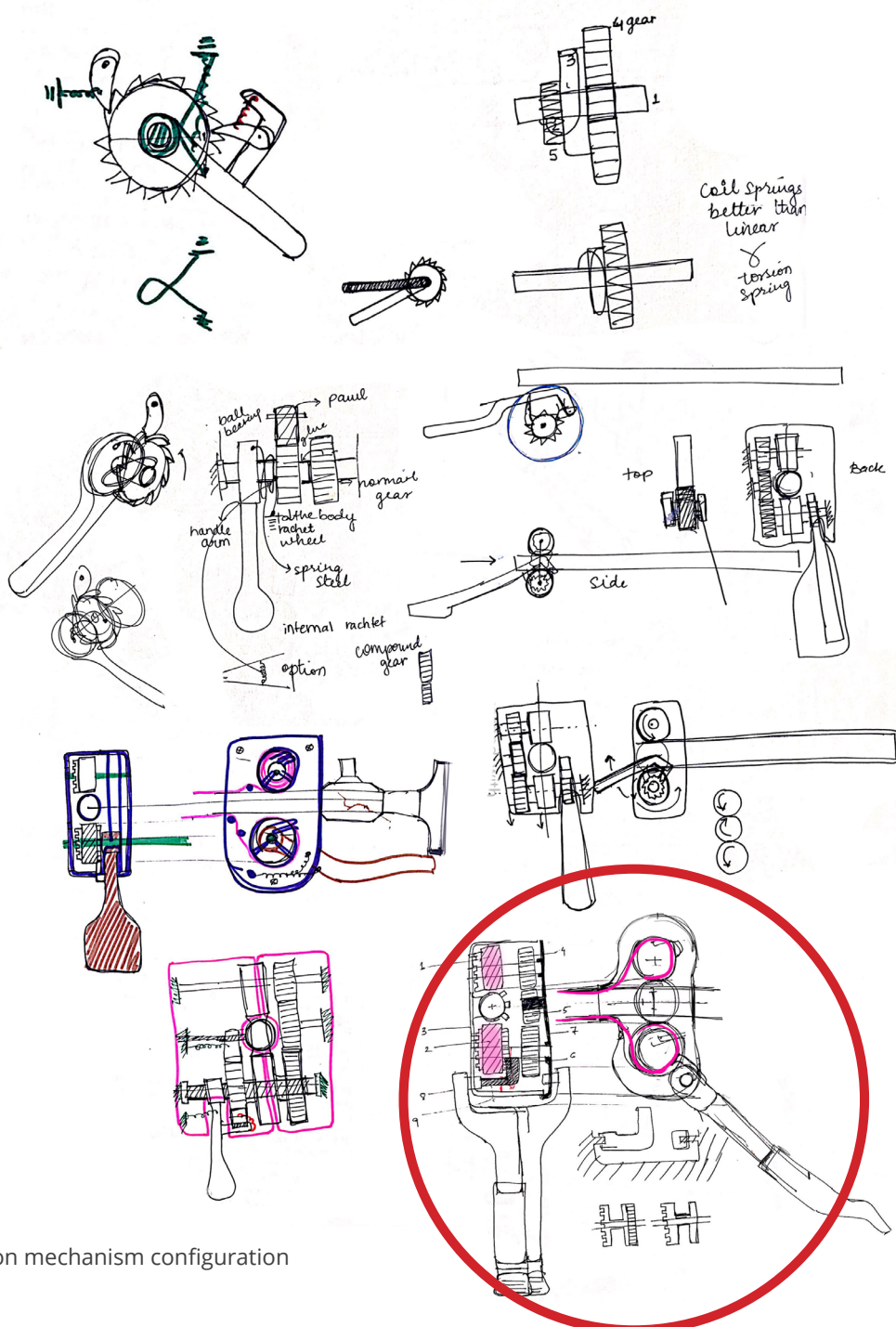

Fig. 96 Ideations on mechanism configuration



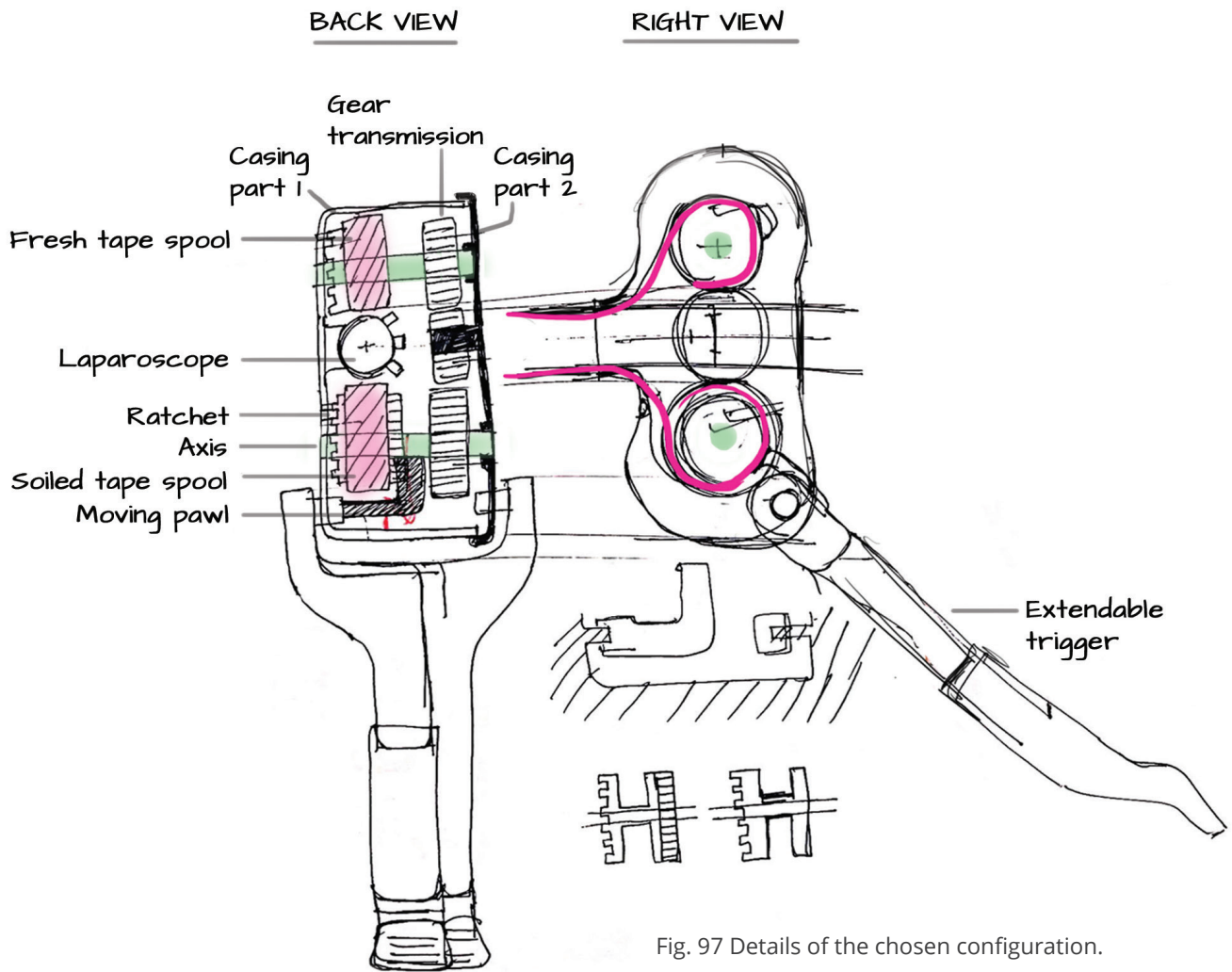

Fig. 97 Details of the chosen configuration.

The chosen configuration was detailed out (figure 97). Apart from the details of the mechanism, the surrounding details such as the casing, incorporating the trigger and attachment of the metal sheath to the mechanism were also reviewed. The metal sheath is attached to the plastic casing of the mechanism via force fit (figure 98). Plastic protusions are made in the casing which act as guides to the tape to pass from the mechanism into the metal sheath. Based on this a CAD model was developed which combined all these ideas into a unified proposal. This proposal is showcased in the next chapter.

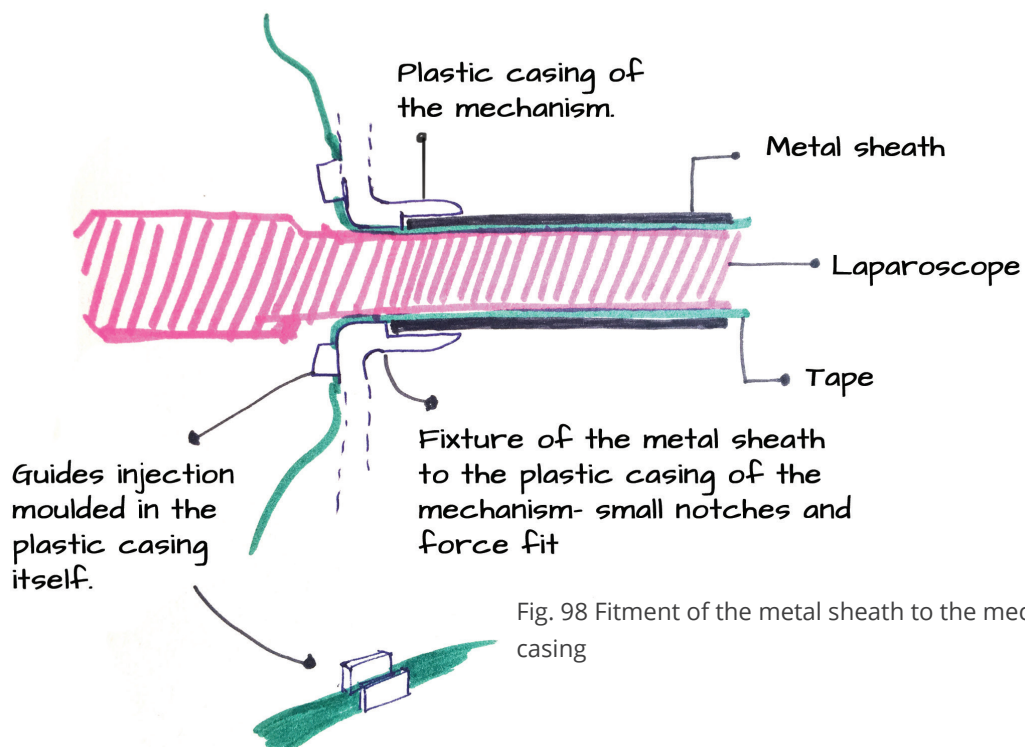
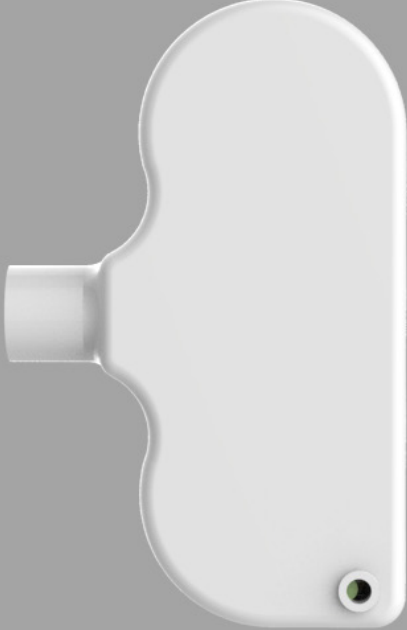
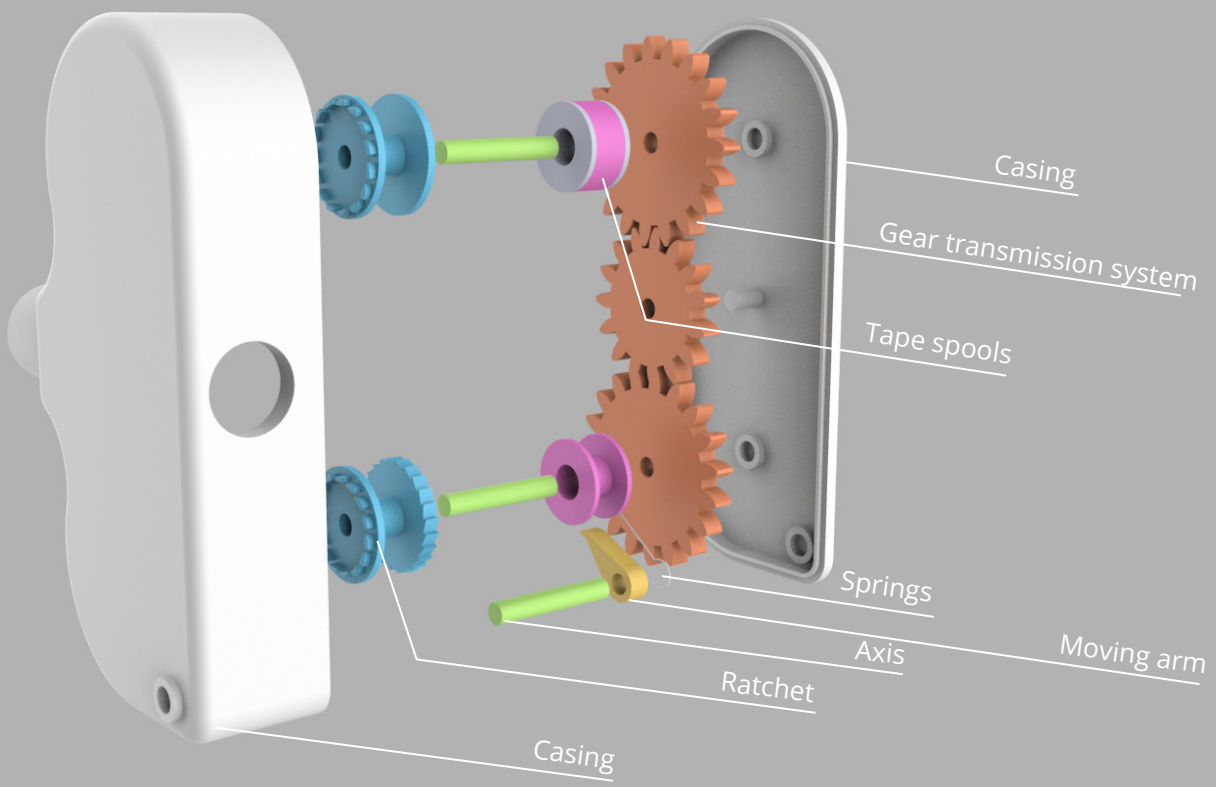
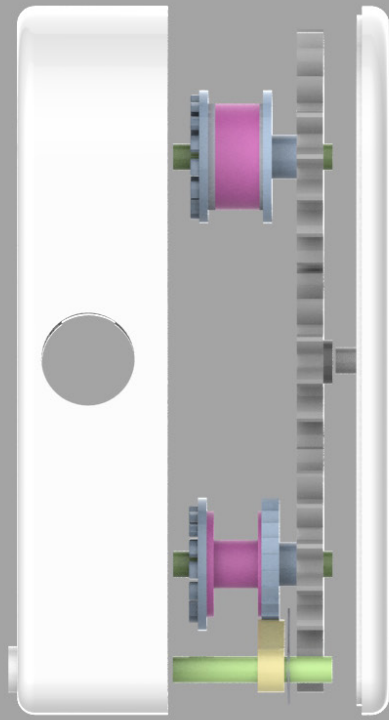

Fig. 98 Fitment of the metal sheath to the mechanism casing

# 11.4 The mechanism proposal

This chapter showcases this mechanism proposal for the envisioned device.





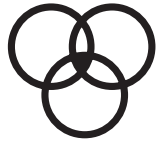

## The combined design proposal

All the three proposals of the device tip, the device interaction and the mechanism are combined in this chapter to provide the idea of the whole solution. This proposal is the result of this thesis. In this chapter this proposal is explained and its details are elaborated. Further, the manufacturing and the material aspects are discussed along with the cost structure.

12.1 Explanation of the proposal

12.2 Product use scenario

12.3 Tape design proposal

12.4 Material & manufacturing

12.6 Cost

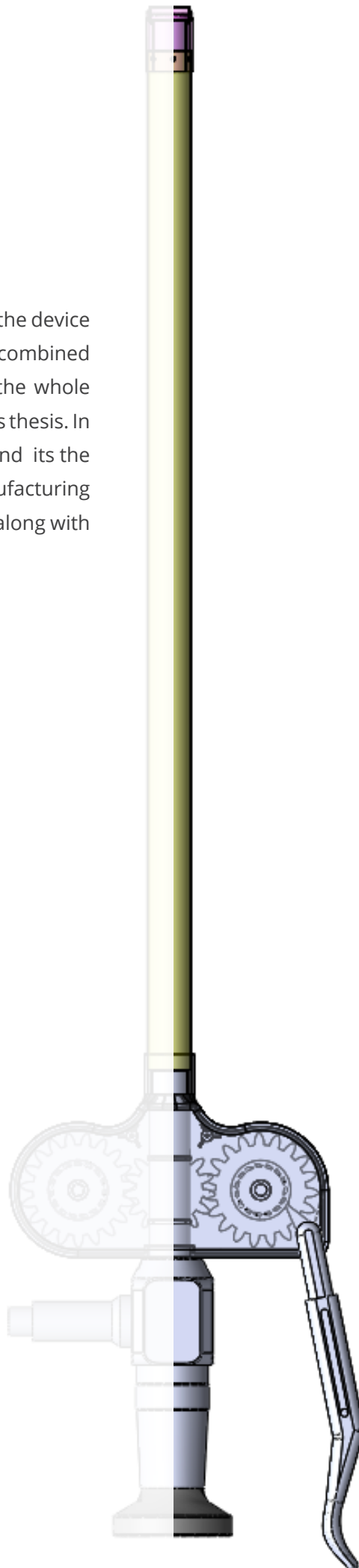

## 12.1 Explanation of the proposal.

Figure 99 shows the device design proposal next to the laparoscope. The outcomes of the three modules of the device tip, the device interaction and the mechanism are merged into a unified proposal. This proposal fulfills the contextual demands and stake holder needs with respect to the problem of laparoscope lens tip contamination. In other words it provides a holistic solution. This proposal will have to be further engineered to meet the technical demands. Details of the proposal are explained in this chapter.



Fig. 99 The proposal

## The interaction

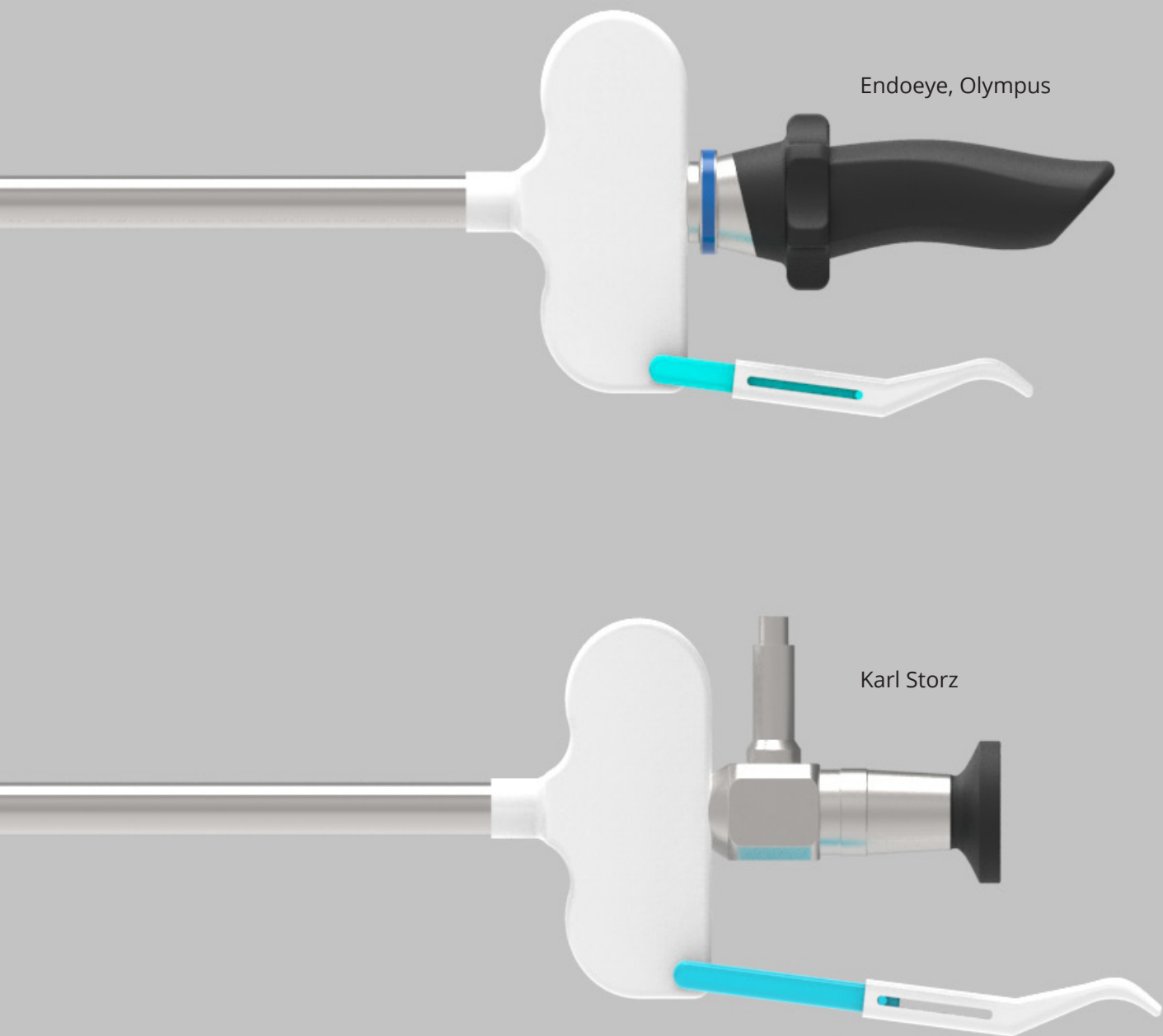

Fig. 100 The trigger adapting to various scopes

Figure 100 shows the extension of the trigger with respect to the two different scopes - Karl Storz and Olympus endoeye. The Karl Storz scope will also have a camera attachment to its eye piece. The handle is adjusted according to the required length depending on the scope and also on the surgeon's need.

## The casing

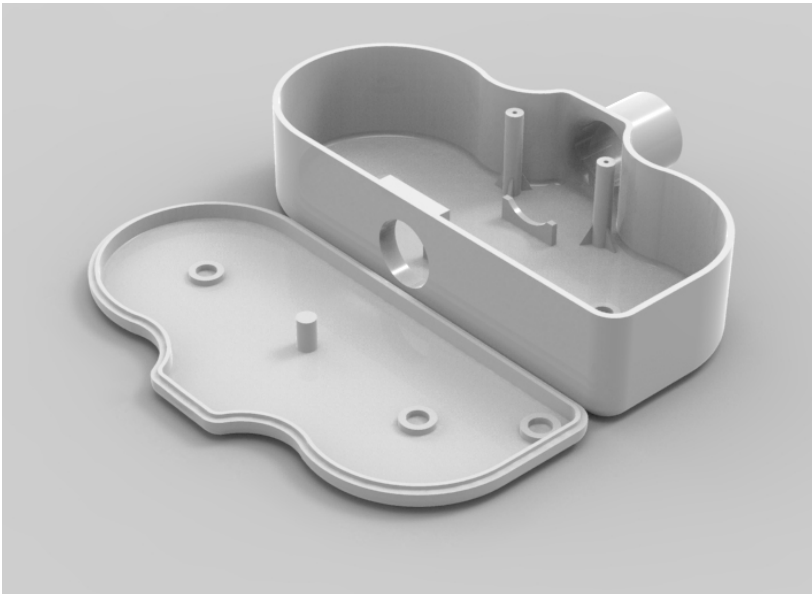
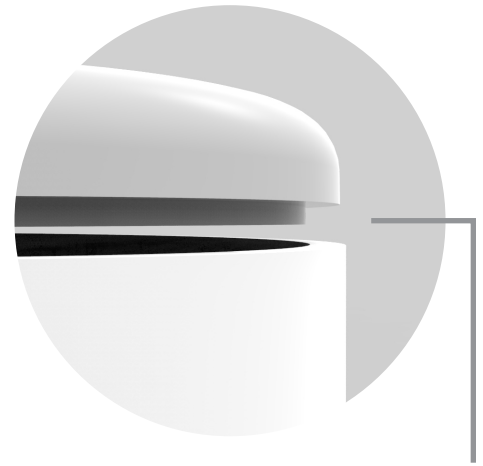
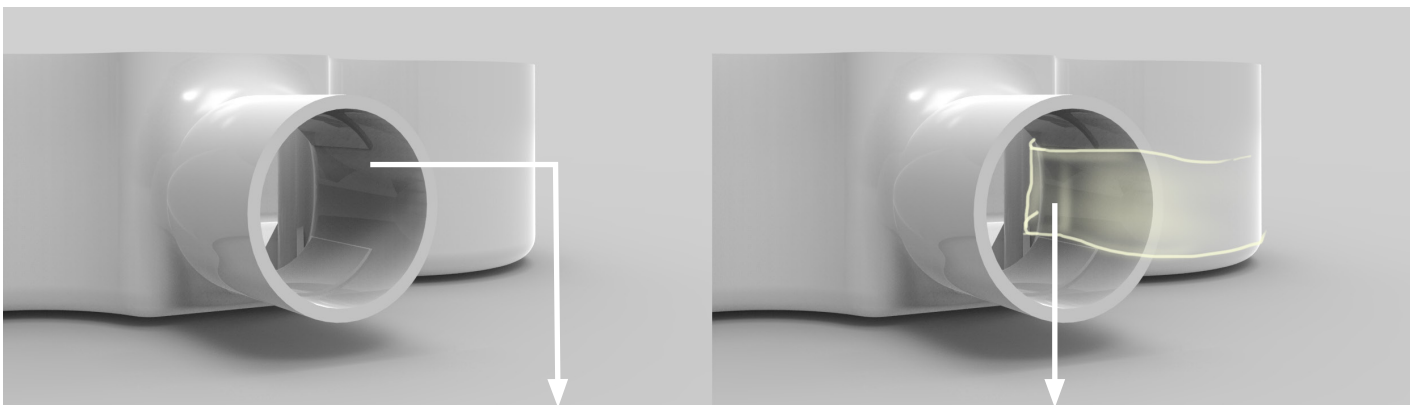

Fig. 101 The casing



The upper and lower part of the casing are snapped together

Fig. 102 The fitment



An indented guide in the plastic casing so that the tape can easily pass from the spool to the metal sheath

Fig. 103 Tape guidance in the casing

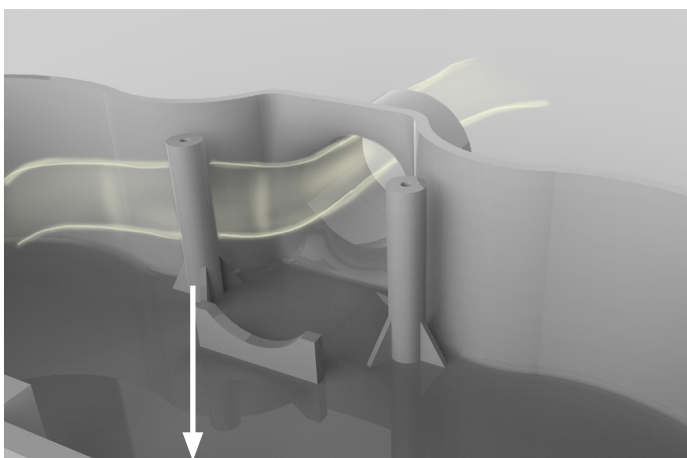

Circular plastic protrusions, which keep the tape in place and also provide tension to it.

Fig. 104 Tape tensioner

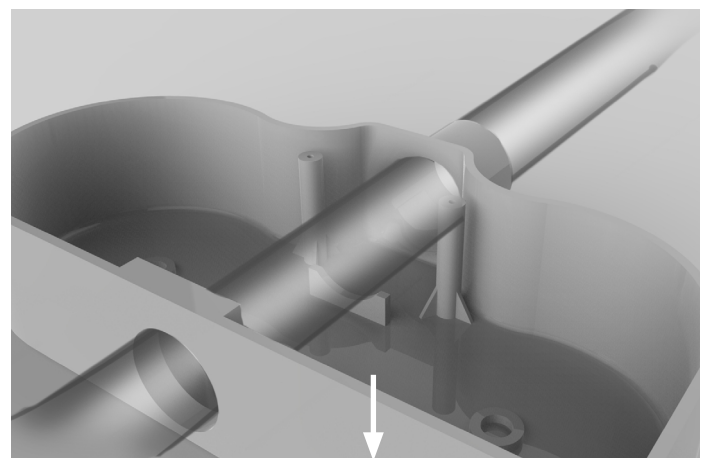

Circular support profiles to support the laparoscope in the casing.

Fig. 105 Support for the laparoscope

## The path of the tape

In the figure 106, how the tape will be placed in the device is shown in yellow. The tape travels from the fresh spool in the top, passes through the tensioner, takes the guided route to enter into the metal sheath. After travelling till the tip of the scope, it comes out of the slot, passes over the slope, encounters a flat edge and falls flat on the surface of the tip. As the tape bends inwards, it goes through the slot at the bottom of the transparent plastic part and begins to travel back to the mechanism. Once it reaches the entrance of the mechanism, it again has to pass through a tensioner, which positions it in place for it to be wrapped back in the spool at the bottom.

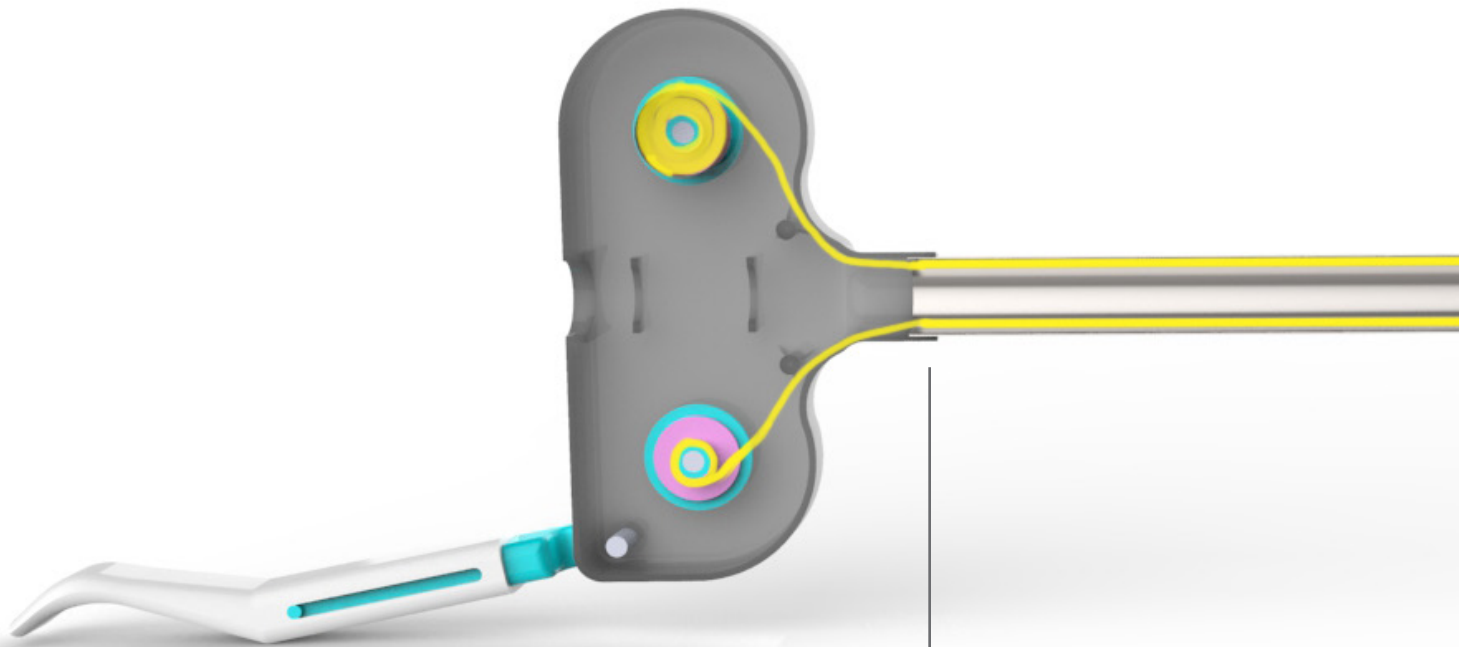

Fig. 106 Path of the tape

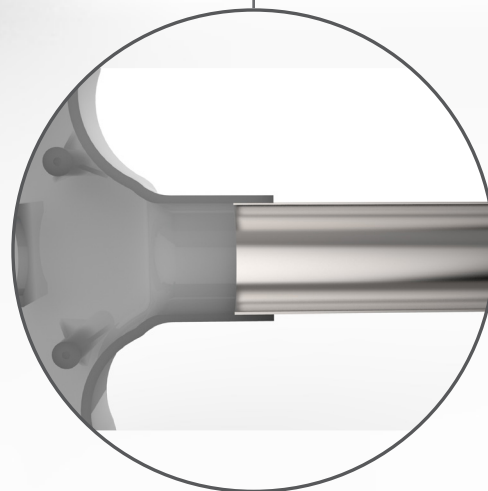

Fig. 107 Force fitment of the metal sheath into the plastic casing



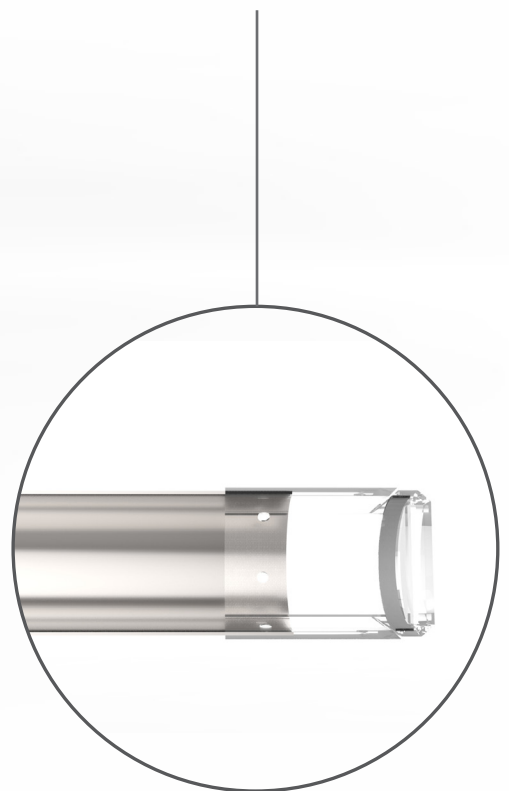
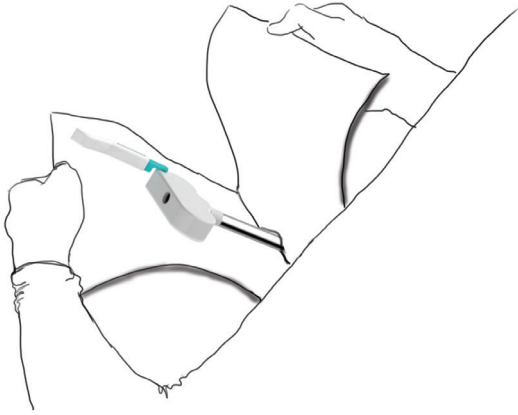

Fig. 108 Co - molding the transparent plastic part over the metal sheath to fix them together.

## 12.2 Scenario of product use

1. Open the protective cover and remove the device



2. Put the device over the laparoscope

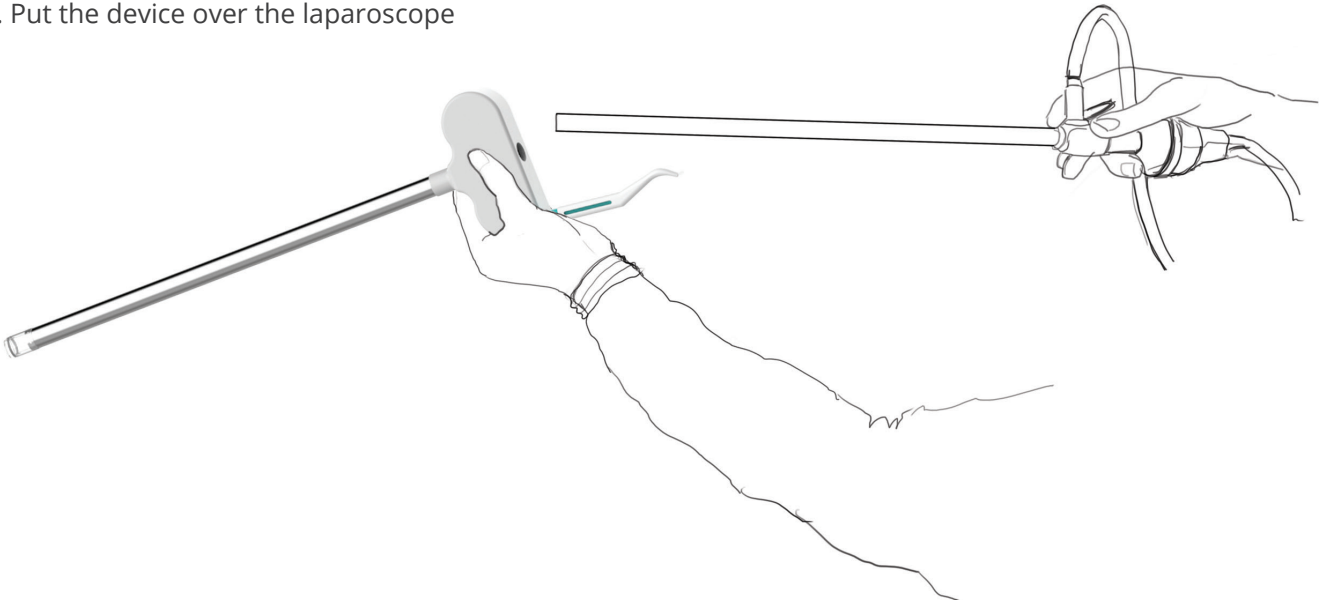

3. Insert the device and laparoscope in the trocar

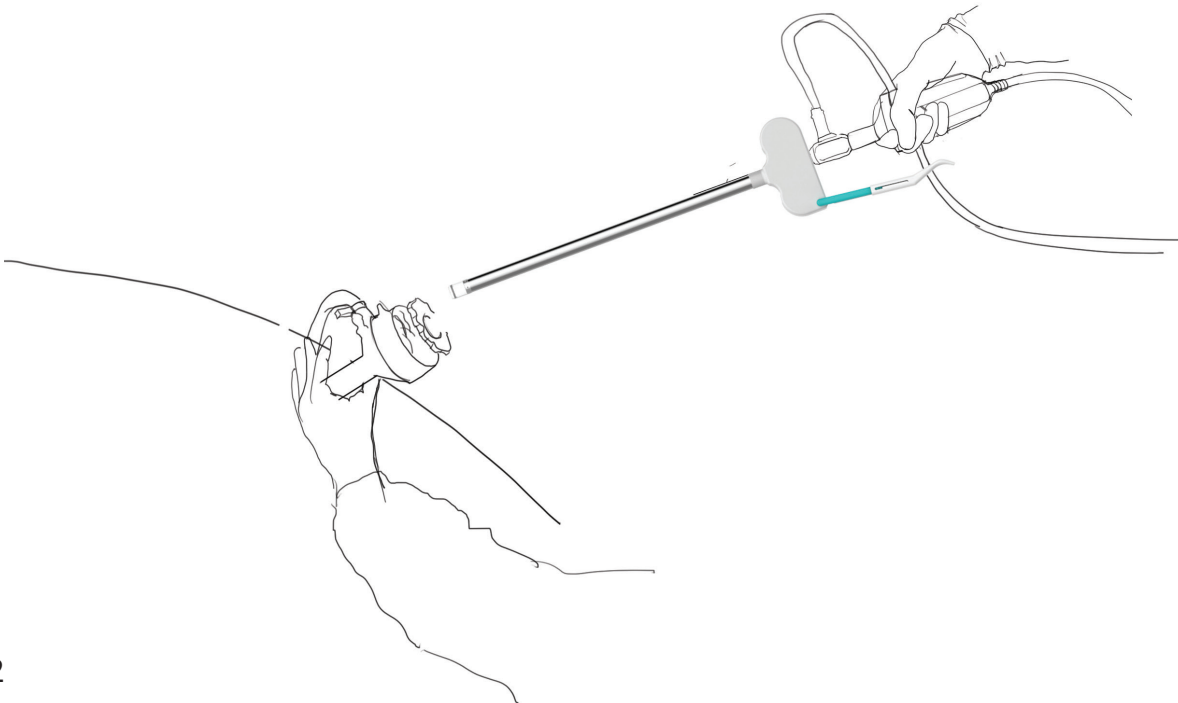

4. The operative field is visible and operation is in progress.

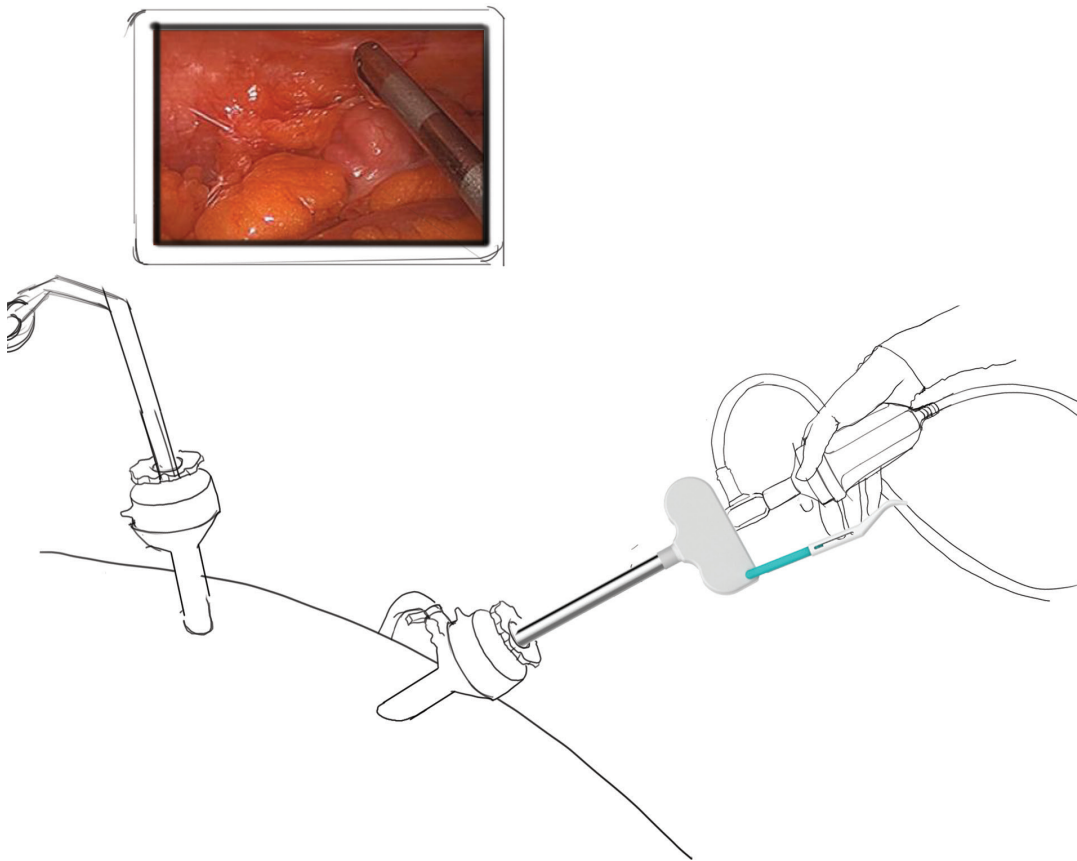

5. During the surgery, the laparoscope tip gets contaminated with blood splashes.

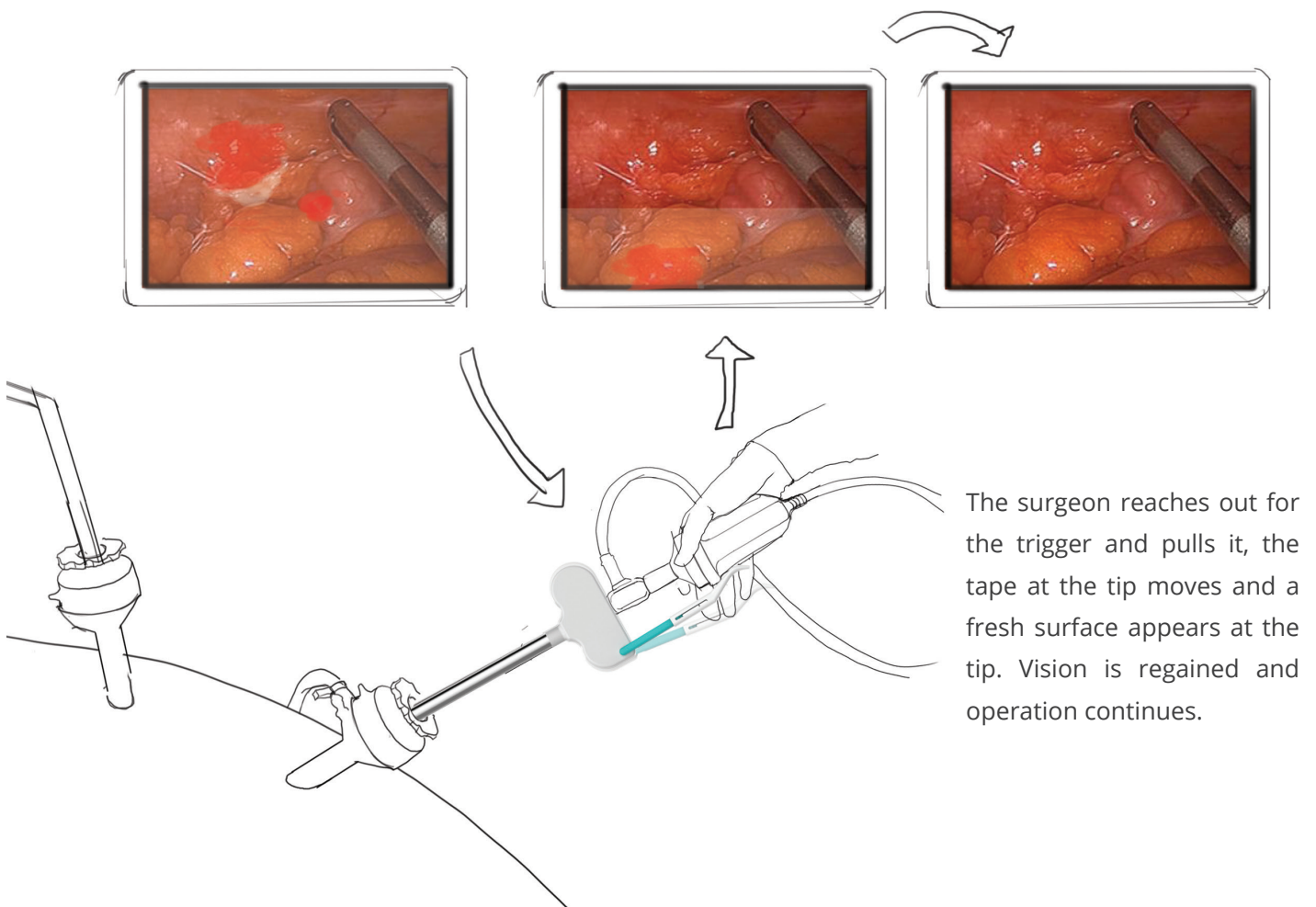

## 12.3 Tape design proposal

During the development process, several insights related to the design of the device were gathered. From some of the insights and the device design reveal how the tape should be. The requirements of the tape design are born out of the development process of the device. These requirements are elaborated below.

First and foremost requirement of the tape is transparency. The tape should allow 100 percent transparency for the vision and also for the light to pass.

The tape should have tensile strength. From the design of the device tip and the mechanism, it is understood that the tape will be under tension, to ensure a smooth movement.

The width of the tape for 10mm diameter scopes should be 6mm. This will vary for different scopes and thus appropriate calculations are needed, depending on the device design.

The tape should have alternate absorbent patches. The absorbent patch will ensure that during each tape movement, the surface of the tip is wiped simultaneously with the same trigger press. This will make sure that all possible contaminants have been removed. The length of these patches will gradually increase with every rotation of the spool as mentioned in chapter 11.2.

The tape should be resistance to heat generated at the tip from the light source. Since the tape is on the surface always and very close to the light fibers, this is an important aspect. Appropriate testing is needed to calculate the temperature at the tip.

The design required tape to be rolled and stored on spools. Therefore during manufacturing or assembly, this has to be taken care of.

Development of such a tape will be possible with the help of relevant expertise and resources.

## 12.4 Costs and post processing of the device

To estimate the cost of such a device, it is essential to know the post processing method, that means if the device is reusable or disposed off. The post processing method dictates the design, kind of manufacturing techniques used, and material choices and thus the cost of the device.

During the discussion with Herke Jan mentioned in chapter 8.2, it was understood that a device of this nature will never be reused in the context of UMC Utrecht. Medical products like trocars, obtrators etc. are very designed very intricately and with high quality material, but still they are discarded after the surgery. This might be because of several factors such as reprocessing them is costly, safety standards are very high, the products are not designed to allow reprocessing etc. The device designed for ensuring a clean laparoscope tip will thus also be discarded. Even if the device allows it to be reused, it won't be done so considering the perception towards this problem. As the problem is looked on as a very small problem, the device for it will also be a very inexpensive one. Because having an expensive device for a problem of this nature, would make them think, they might as well proceed the way they are currently doing instead of investing money.

The decision to have the system disposable was taken. This meant the life span of the device would be no longer than one surgery. This further indicates that the components need not have a longer life.

To estimate the cost of the device, the analysis of the existing solutions in the market done in chapter 5.1 is used. Costs of not all existing devices are not known. However, the most cheap solution amongst all, is the Floshted. It is a fairly recent company. The product consists of similar plastic sheath, tubes and other peripherals. It cleans the lens tip by using the insufflation gas and also utilizes saline water. It costs 50\$.

Considering this as the competition to the new device, the price of the device should be less than it. Thus the overall cost per unit of the new device is predicted as less than 50 \$. This would also include the tape costs. The cost per unit would reduce further depending on the number of devices. More detailed analysis of material, manufacturing technique, size of the product, labour costs and time taken will be required to gain a clear idea of the costs. This can be done better after the engineering of the device as component details will be more clear then.

## 12.5 Materials and manufacturing

Material and corresponding manufacturing method for each component is described below:

Starting from the transparent plastic tip - This will be made by medical grade plastic which provides transparency as that is the key requirement. Plastic will allow all the details essential to the tape in the design. Considering plastic, this part will be created through injection moulding.

The metal sheath: The metal sheath will be made from stainless steel. Using metal for this part will help in reducing the overall dimensions.

The transparent plastic tip and the metal sheath: These two parts will be joined via co- moulding process, where the plastic part is moulded over the metal tube to ensure seamless and strong connection.

The mechanism: The entire mechanism can be achieved in plastic through injection moulding. Having a single material here will not only reduce costs but also help in responsible disposal of the instrument. For flexible parts, compliant mechanisms can be explored. Compliant plastic parts can provide flexibility which reduces the need for metal springs.

The metal sheath and the mechanism: These two components are joined by force fitment, the same way the metal sheath is attached to the plastic part in the obturator. This can be forced out during disposal.

The triggers: This extendable trigger design can be achieved in plastic, through injection moulding. The plastic used here should allow for movements without wearing as they will be extended.

The tape: the material of the tape, will require further research and relevant expertise. However, requirements of the tape design can be discussed which would work efficiently with this device design. This is described in the next chapter.







# CONCLUSION & RECOMMENDATIONS

The result of this thesis is a solution proposal for the problem of laparoscope lens contamination. This proposal fulfills the user and context requirements learned during research. The efficiency of the solution is currently proven in modules with the vision that when combined it will continue to be the same.

Two important next stages can be charted out for the concept – prototyping and user testing. These two stages will be interlinked and will involve several iteration rounds of prototyping, testing and incorporating user feedback. Recommendations in each of these activities are elaborated further.

## Prototyping:

Initially the prototypes of each module will have to be built, post which the whole device can be constructed. For the tip, consultation with material and manufacturing experts is needed. The tip involves transparent plastic and metal components and thus needs appropriate manufacturing methods. For building the mechanism, detailed engineering of the components is required. Determining the size, composition and placement of the gears and ratchet will have to be figured out. For the trigger, the extendable aspect will have to be tested and created. At the initial prototyping phase, various experts need to be involved for better development of the device. Upon prototyping the individual modules, they can be combined into a complete functioning prototype.

## Testing:

The testing of the functioning prototype should be conducted with all the stakeholders identified in chapter 2.1. Testing only with the surgeons, will not provide the holistic feedback on the device. Getting feedback from the purchasing department will provide business related insights, feedback from the nurses will help in providing preparation aspects of it insights from the post processing department will help to understand how can it be disposed responsibly. This holistic feedback will ensure that the developed product will adapt to the complex environment. This is the most important aspect to keep all the users involved. Testing with each will have to be different depending on the information needed.

The second important part of testing is testing with the main users – surgeons. Mock and clinical testing sessions will have to be designed with the surgeons to gain their feedback. It will be important to see if they perceive the interaction of the device as it was thought during the design process.

## Tape design:

Next to the device development, the tape will also have to be developed. Incorporating all the wishes of the tape mentioned in the chapter 13 will require material expertise, research and development. The tape is as crucial as the entire device. Thus an efficient tape design will improve the overall product efficiency.

## Incorporating feedback:

Throughout this process of development, where various activities will be conducted and many experts will be involved, it will be necessary to keep an overview and track of the development. This will include timely acquiring and incorporating the feedback. An industrial designer will be needed to keep a track of this.



# REFLECTION

Designing for the surgical context has been an amazing experience for me. Being in UMC Utrecht, I could tap into knowledge of many people. All the stakeholders were available at one place everyday, This was the most interesting part. I learned the art of networking and scheduling appointments and managing an agenda, which I had never done before.

Observing the surgeries was a great experience for me. I had never been into such a critical environment before. Through this project and being at Pontes, I could observe three different surgeries. I could observe and spot so many insights and problems. The context and stakeholders being so close and approachable to me, was the best part of the project for me.

The design process through structured now, was not so structured when being carried out. It was quite an uncertain and fuzzy process at many times. But once I could figure the next steps, things became more clear. One thing which I could not achieve in the design process was testing or validating aspects with the user. Most of my time and effort went into conceptualization. But this could be done better now in the next phase of product development.

# References

- Aarts, S. (2015). System for in-situ cleaning of the distal window of a laparoscope. Retrieved from <https://repository.tudelft.nl/islandora/object/uuid:47e6c88a-110f-4db6-b952-43669335186b?collection=education>
- Abbitt, D., Khallouq, B., & Redan, J. (2017). Quantifying Intraoperative Laparoscopic Visual Field Opacity. *JLS : Journal of the Society of Laparoendoscopic Surgeons*, 21(2). <https://doi.org/10.4293/JLS.2017.00004>
- Anderson, S., Zimmerman, J., Houston, E., Farino, K., & Begg, N. (2010). Design of an Endoscope Lens Shielding Device for Use in Laparoscopic Procedures. *Journal of Medical Devices*, 4(2), 027515. <https://doi.org/10.1115/1.3442792>
- Bladeless Optical Trocars Market will touch a new level in upcoming year – Key Players involved in the research like Medtronic, Johnson and Johnson, Cooper, Conmed, B. Braun, Teleflex – Industry Chronicles. (n.d.). Retrieved August 23, 2019, from <https://industrychronicles.com/2019/02/19/bladeless-optical-trocars-market/>
- Broderick, R. C., Omelanczuk, P., Harnsberger, C. R., Fuchs, H. F., Berducci, M., Nefa, J., ... Horgan, S. (2015). Laparoscopic cholecystectomy using a novel single-incision surgical platform through a standard 15mm trocar: initial experience and technical details. *Surgical Endoscopy*, 29(5), 1250–1256. <https://doi.org/10.1007/s00464-014-3779-0>
- ENDOPATH XCEL® Trocars with OPTIVIEW® Technology | Ethicon. (n.d.). Retrieved April 21, 2019, from <https://www.ethicon.com/na/products/access/trocars/endopath-xcel-trocars-optimview-technology>
- Ferreira, H. (2015). Chapter-01 Equipment in Laparoscopic Surgery. In *A Manual of Minimally Invasive Gynecological Surgery* (pp. 1–12). Jaypee Brothers Medical Publishers (P) Ltd. [https://doi.org/10.5005/jp/books/12446\\_2](https://doi.org/10.5005/jp/books/12446_2)
- Global Laparoscopy and Endoscopy Devices Market, 2025 - Focus on Surgical Procedures (Cholecystectomy and Hysterectomy) and Product Types (Arthroscopes, Neuroendoscopes, Cystoscope, and Bronchoscopes). (2018). Retrieved August 11, 2019, from <https://www.globenewswire.com/news-release/2018/09/19/1572863/0/en/>
- Global-Laparoscopy-and-Endoscopy-Devices-Market-2025-Focus-on-Surgical-Procedures-Cholecystectomy-and-Hysterectomy-and-Product-Types-Arthroscopes-Neuroendoscopes-Cystoscope-and-Bro.html
- Handheld Tape Dispenser: Pull and cut tape in a single motion. (n.d.). Retrieved July 23, 2019, from <https://www.vat19.com/item/handheld-tape-dispenser>
- Hemed, A. (2017). Modeling Time-Dependent Performance of Submerged Superhydrophobic or Slippery Surfaces. Virginia Commonwealth University. Retrieved from [https://www.researchgate.net/publication/321731945\\_Modeling\\_Time-Dependent\\_Performance\\_of\\_Submerged\\_Superhydrophobic\\_or\\_Slippery\\_Surfaces](https://www.researchgate.net/publication/321731945_Modeling_Time-Dependent_Performance_of_Submerged_Superhydrophobic_or_Slippery_Surfaces)
- Jategaonkar, P. A., Jategaonkar, S. P., & Yadav, S. P. (2016). Simple, rapid and effective technique for intracorporeal defogging of laparoscopic lens. *Hellenic Journal of Surgery*, 88(3), 214–216. <https://doi.org/10.1007/s13126-016-0320-z>

- John P. Newton, I. (2012). Method and Apparatus for Cleaning the Field of View of an Endoscopic Lens. Retrieved from <https://patents.google.com/patent/US20120178995>
- Kreeft, D., Arkenbout, E. A., Henselmans, P. W. J., van Furth, W. R., & Breedveld, P. (2017). Review of Techniques to Achieve Optical Surface Cleanliness and Their Potential Application to Surgical Endoscopes. *Surgical Innovation*, 24(5), 509–527. <https://doi.org/10.1177/1553350617708959>
- laserstone. (2016). Laparoscopic Cholecystectomy - Laser Stone Surgery & Endoscopy Centre. Retrieved May 11, 2019, from <http://www.laserstonesurgery.org/project/laparoscopic-cholecystectomy/>
- Lawrentschuk, N., Fleshner, N. E., & Bolton, D. M. (2010). Laparoscopic Lens Fogging: A Review of Etiology and Methods to Maintain a Clear Visual Field. *Journal of Endourology*, 24(6), 905–913. <https://doi.org/10.1089/end.2009.0594>
- Manning, T. G., Perera, M., Christidis, D., Kinnear, N., McGrath, S., O'Beirne, R., ... Lawrentschuk, N. (2017). Visual Occlusion During Minimally Invasive Surgery: A Contemporary Review of Methods to Reduce Laparoscopic and Robotic Lens Fogging and Other Sources of Optical Loss. *Journal of Endourology*, 31(4), 327–333. <https://doi.org/10.1089/end.2016.0839>
- Matern, U., & Waller, P. (1999). Instruments for minimally invasive surgery: principles of ergonomic handles. *Surgical Endoscopy*, 13(2), 174–182. Retrieved from <http://www.ncbi.nlm.nih.gov/pubmed/9918626>
- Middlesworth Mark. (n.d.). 8 Fundamental Ergonomic Principles for Better Work Performance. Retrieved July 20, 2019, from <https://ergo-plus.com/fundamental-ergonomic-principles/>
- Mohr, C. (2009). Catherine Mohr: Surgery's past, present and robotic future | TED Talk. Retrieved from [https://www.ted.com/talks/catherine\\_mohr\\_surgery\\_s\\_past\\_present\\_and\\_robotic\\_future?language=en](https://www.ted.com/talks/catherine_mohr_surgery_s_past_present_and_robotic_future?language=en)
- Najmaldin, A., & Guillou, P. J. (1998). A guide to laparoscopic surgery. Blackwell Science. Retrieved from [https://books.google.nl/books/about/A\\_Guide\\_to\\_Laparoscopic\\_Surgery.html?id=uaSGQgAACAAJ&redir\\_esc=y](https://books.google.nl/books/about/A_Guide_to_Laparoscopic_Surgery.html?id=uaSGQgAACAAJ&redir_esc=y)
- Park, J.-S., Park, J.-H., & Lee, D.-W. (2018). Optically transparent super-hydrophobic thin film fabricated by reusable polyurethane-acrylate (PUA) mold. *Journal of Micromechanics and Microengineering*, 28(2), 025004. <https://doi.org/10.1088/1361-6439/aa9f04>
- RANZCOG WEBSITE - Laparoscopy. (n.d.). Retrieved March 8, 2019, from <https://www.ranzcog.edu.au/Womens-Health/Patient-Information-Resources/Laparoscopy>
- Soper, N. J., & Malladi, P. (2018). Laparoscopic cholecystectomy - UpToDate. Retrieved March 21, 2019, from <https://www.uptodate.com/contents/laparoscopic-cholecystectomy>

Spight, D. H., Hunter, J. G., & A., J. B. (2011). Schwartz's Principles of Surgery. In F. C. Bruinickardi (Ed.), Schwartz's Principles of surgery (10th ed., Vol. 61, pp. 415–441). McGraw-Hill Education. [https://doi.org/10.1016/s0377-1237\(05\)80185-6](https://doi.org/10.1016/s0377-1237(05)80185-6)

Stassen, H. G., Dankelman, J., & Grimbergen, C. A. (1999). Open versus minimally invasive surgery: a man-machine system approach. *Transactions of the Institute of Measurement and Control*, 21(4–5), 151–162. <https://doi.org/10.1177/014233129902100403>

Storz Compatible 10mm 30 Degrees Laparoscope Autoclave Rigid Lens Endoscope Laparoscopy Instruments - Buy Laparoscopy Instruments,Laparoscope,Laparoscopic Surgical Instruments Product on Alibaba.com. (n.d.). Retrieved August 11, 2019, from [https://www.alibaba.com/product-detail/Storz-compatible-10mm-30-degrees-laparoscope\\_62110738195.html?spm=a2700.7724838.2017115.61.243c227eMfX8qf](https://www.alibaba.com/product-detail/Storz-compatible-10mm-30-degrees-laparoscope_62110738195.html?spm=a2700.7724838.2017115.61.243c227eMfX8qf)

Sunny, S., Cheng, G., Daniel, D., Lo, P., Ochoa, S., Howell, C., ... Aizenberg, J. (2016). Transparent antifouling material for improved operative field visibility in endoscopy. *Proceedings of the National Academy of Sciences of the United States of America*, 113(42), 11676–11681. <https://doi.org/10.1073/pnas.1605272113>

Supe, A. N., Kulkarni, G. V., & Supe, P. A. (2010). Ergonomics in laparoscopic surgery. *Journal of Minimal Access Surgery*, 6(2), 31–36. <https://doi.org/10.4103/0972-9941.65161>

Types of Endoscopy | Cancer.Net. (2017). Retrieved February 26, 2019, from <https://www.cancer.net/navigating-cancer-care/diagnosing-cancer/tests-and-procedures/types-endoscopy>

UMC Utrecht OK's,Projecten - INTER. (n.d.). Retrieved August 23, 2019, from <https://www.inter.nl/projecten/umc-utrecht-oks-2/>

# Appendices

Appendix A : Graduation brief

Appendix B : Questionnaires prepared for stakeholder interviews

Appendix C : A4 printouts used for interviews.

Appendix D : Stakeholder nterview transcripts and interpretation

Appendix E : Sample and filled in questionnaires

Appendix F : Timelines of the observed surgeries.

Appendix G : Collages of images for analyzing laparoscope holding style and its analysis.

Appendix H : Ergonomic analysis from the collages.

Appendix I : Documentation of existing solutions

Appendix J : Discussions with Arien Broere and Stefan Been

Appendix K : Interview KNO surgeon

Appendix L : Discussion with Assi. Prof. Murali Ghatkesar

Appendix M : Results of ideation session

Appendix N : Tests of ClearX hydrophobic screen protector

Appendix O : Sketches - ideation round 2

Appendix P : Test of the stage 1 tip design

Appendix Q : Trying the trigger designs with the postures from the collages.

Appendices B, D, E, J and K are confidential appendices.