

Modular Multilevel Series-Parallel Converter with Parallel-Connected Phases and Coupled Inductors for High-Current Applications

Concha, Esteban ; Rivera, Sebastian ; Dekka, Apparao; Lizana F., Ricardo

DOI

[10.1109/CHILECON60335.2023.10418732](https://doi.org/10.1109/CHILECON60335.2023.10418732)

Publication date

2023

Document Version

Final published version

Published in

Proceedings of the 2023 IEEE CHILEAN Conference on Electrical, Electronics Engineering, Information and Communication Technologies (CHILECON)

Citation (APA)

Concha, E., Rivera, S., Dekka, A., & Lizana F., R. (2023). Modular Multilevel Series-Parallel Converter with Parallel-Connected Phases and Coupled Inductors for High-Current Applications. In *Proceedings of the 2023 IEEE CHILEAN Conference on Electrical, Electronics Engineering, Information and Communication Technologies (CHILECON)* (Proceedings - IEEE CHILEAN Conference on Electrical, Electronics Engineering, Information and Communication Technologies, ChileCon). IEEE. <https://doi.org/10.1109/CHILECON60335.2023.10418732>

Important note

To cite this publication, please use the final published version (if applicable). Please check the document version above.

Copyright

Other than for strictly personal use, it is not permitted to download, forward or distribute the text or part of it, without the consent of the author(s) and/or copyright holder(s), unless the work is under an open content license such as Creative Commons.

Takedown policy

Please contact us and provide details if you believe this document breaches copyrights. We will remove access to the work immediately and investigate your claim.

Green Open Access added to TU Delft Institutional Repository

'You share, we take care!' - Taverne project

<https://www.openaccess.nl/en/you-share-we-take-care>

Otherwise as indicated in the copyright section: the publisher is the copyright holder of this work and the author uses the Dutch legislation to make this work public.

Modular Multilevel Series-Parallel Converter with Parallel-Connected Phases and Coupled Inductors for High-Current applications

1st Esteban Concha

Centro de Energia
UCSC,
Concepcion 4090541, Chile
fbarrera@ing.ucsc.cl

2nd Sebastian Rivera

Electrical Sustainable Energy, Department
Delft University of Technology,
Delft 2628 CD, Netherlands
s.rivera.i@ieee.org

3rd Apparao Dekka

Department Electrical Engineering,
Lakehead University,
Thunder Bay, Canada
dapparao@ieee.org

4th Ricardo Lizana F.

Centro de Energia,
UCSC,
Concepcion 4090541, Chile
ricardolizana@ucsc.cl

Abstract—Modular multilevel series-parallel converters (MM-SPC) have become a suitable solution to provide higher operating voltages, fault tolerance operation, and reliability at a reduced cost, due to their ability to achieve a simpler internal voltage balance. Therefore, MMSPC is a promising solution for applications where the nominal operating conditions are high voltage levels on the DC side and high current ratings on the AC side of the system. To allow this operation, it is necessary to design the system with parallelization in each phase. Therefore, this article proposes a design that incorporates parallelization in each phases and analyzes the internal cross-circulating current generated due to parallelization. This current creates an unbalance and internal losses in the converter. In order to compensate for the cross-circulating current, two cases are compared: the first one with decoupled inductors in their phases, and the second one with coupled inductors. This way, a comparison is made to determine which case provides greater compensation of the circulating current, allowing for the delivery of a high current at the converter's output with the least possible imbalance and internal losses.

MMSPC, cross-circulating current, coupled inductors.

I. INTRODUCTION

MODULAR multilevel converters (MMC) have evolved into the perfect option to interconnect medium-voltage (MV) and high-voltage (HV) DC-links with a low-voltage (LV) AC-grid. MMC offers multiple advantages compared with other traditional power converters like the two-level voltage source converter (VSC), such as reduced total harmonic distortion (THD) performance, lower common-mode voltage, fault-tolerant operation, modularity and scalability to name a few [1]–[3]. However, MMC has several key control objectives like the voltage balance among the modules and between the arms, DC-link current, AC-side currents, and circulating currents, that need to be fulfilled to achieve a reliable and safe operation of the system [4], [5].

Recently, several efforts have been made in the development of new module configurations for the traditional MMC to achieve an inherent energy balance, smaller voltage ripple, and further reduction of power losses, to name a few [6]. Among

these new circuits, the modular multilevel series/parallel converter (MMSPC) owns important advantages compared with the traditional power modules. The MMSPC allows not only the series interconnection among them, but also allows their parallel interconnection. This additional degree of freedom in the switching states allows us to achieve different control objectives, such as the internal voltage balance without the need of extra sensors or control algorithms. This connection also leads to the reduction of the total parasitic inductance and resistance in the different energy paths [7]–[10].

Moreover, in the traditional MMC configuration, half of the current of the AC system flows through the positive and negative arm of each phase of the system, implying certain restrictions due to the maximum current that the semiconductors of the system can withstand. For this reason, the parallel interconnection in each phase of the system allows dividing the current in each arm of the converter by a factor of $2Y$, where Y is the number of equivalent phases that are interconnected in parallel [11].

Hence, the parallel interconnection of the system phases generates a cross-circulating current, caused by the parameters mismatch in the components or difference in the instantaneous voltages of each interconnected phase. This cross-circulating current creates an increase in the internal losses of the system, as well as compromising the stability of the system due to the increase in the ripple voltage of the capacitors of each module.

In this work, an MMSPC with parallel connected phases is presented. The effect generated by the parameters mismatch between the phases that are connected in parallel, along with the analysis of the effect on the ripple of the capacitors in each one of the modules is analyzed. Also, the proposed system presents the advantage of utilizing coupled inductors in the interconnection of the AC system, leading to the cancellation of the cross-circulating current components, and thus reducing the internal losses, and keeping the system to operate in a stable operation region.

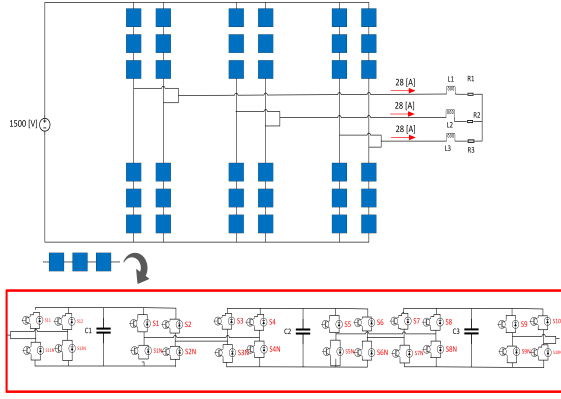

Figure 1: Proposed system topology

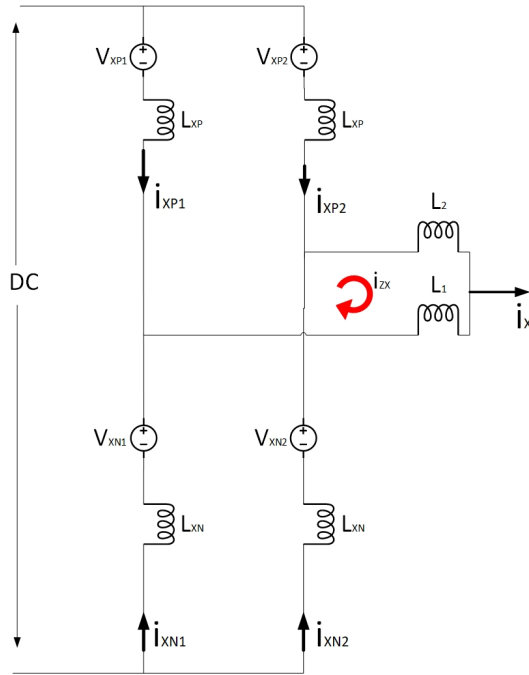

Figure 2: Model of the proposed system for $\Upsilon = 2$

II. TOPOLOGY DESCRIPTION

The proposed system configuration is illustrated in Fig.1. The converter is based on a three-phase modular multilevel converter (MMC) topology, in which each phase of the converter can be interconnected by Υ equivalent phases connected in parallel. In Fig.1(a), the system evaluated in this paper is presented for $\Upsilon = 2$, or in other words, each phase of the system is designed by two equivalent phases connected in parallel. Each phase of the converter is composed of two arms, the positive and negative arm, and each arm of the proposed system is composed of several (N) modules based on a modular multilevel series/parallel converter (MMSPC). The reason behind the use of MMSPC modules is to enable the internal balance among the storage units without complex control or modulation techniques [9], [12], [13]. In Fig.1(b), the proposed system with $N = 3$ is depicted.

The aforementioned structure resembles the traditional MMC, given that the DC system is connected at the extremes of the positive and negative arms of each phase of the system, while the AC system is interconnected at the midpoints of each phase. The AC system is composed of a resistive-inductive type load as shown in Fig.1.

III. INTERNAL CROSS-CIRCULATING CURRENT

The parallelization of the branches in each phase of the system generates an internal cross-circulating current, which can cause unbalance and internal losses. To identify the main factors that generate the cross-circulating current, the model of one phase of the proposed system with $\Upsilon = 2$ is presented in Fig.2. In this model, the N modules based on MMSPC are represented by a controllable voltage source v_{xyj} where $x \in \{a, b, c\}$ which defines the phase of the load, y defines the positive or negative arm of the system ($y \in \{p, n\}$), and j defines the parallel phase. In the present study, $j \in \{1, 2\}$ is assumed. Moreover, each arm of the system has an inductance (L_{xy}) and it is implemented with coupled inductors to achieve the parallel interconnection among the phases. These inductors (L_1 and L_2) allow the reduction in the current peaks by having voltage differences between the phases.

The arm currents are represented with i_{xyj} , and they are composed of three main current components: a DC component equivalent to $i_{DC}/3\Upsilon$, where i_{DC} is the DC current that circulating from the DC system to the converter phase. An AC component is equivalent to $i_x/2\Upsilon$, where i_x is the AC load current of the system. Finally, a circulating current is represented with i_{zx} , which circulates internally between the arms of the system and does not have any effect on either the AC or DC sides of the system.

From Fig.2, the following expressions are obtained using Kirchhoff's current law:

$$i_{xp1} + i_{xn1} = i_x/2 - i_{zx} \quad (1)$$

$$i_{xp2} + i_{xn2} = i_x/2 + i_{zx}. \quad (2)$$

Using equation (1) and (2), it is possible to define an expression for the cross-circulating current as follows:

$$\frac{i_{xp2} - i_{xp1} + i_{xn2} - i_{xn1}}{2} = i_{zx}. \quad (3)$$

From equation (3), it can be seen that the cross-circulating current is generated by the instantaneous differences existing among the arm currents of each of the phases connected in parallel. These arm currents are a consequence from the instantaneous differences existing in the power modules, the inductance value mismatch and internal losses (parasitics) of each arm. On the other hand, they also have an effect on the circulating currents, hence further affecting the converter efficiency.

Also, the inherent voltage differences in the arms and cells, besides the tolerance on the component values, further increases the cross-circulating current, which would result in increased losses and unnecessary oversize of the components present in this current path [14]. To reduce these effects,

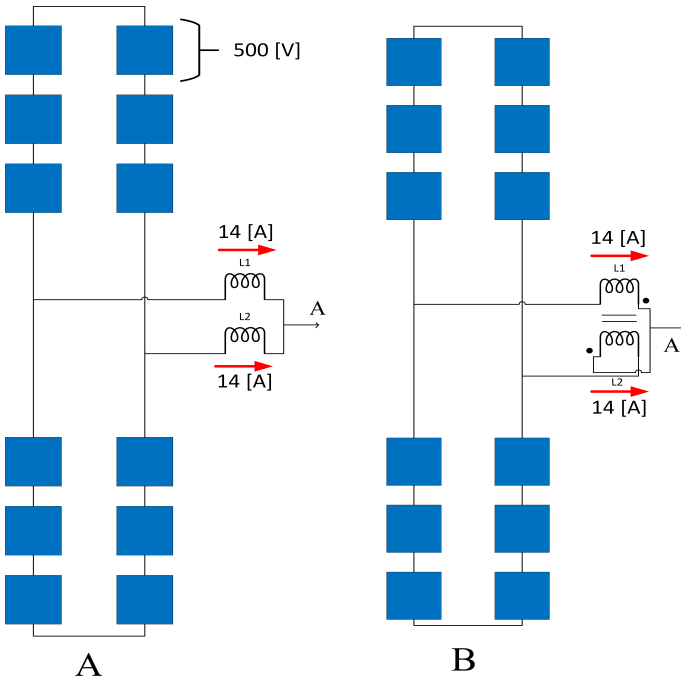

Figure 3: Proposed configurations: a) Inductor in series with the line filter inductor for each phase of the proposed system. b) Coupled inductor.

the solutions presented in Fig.3 can be implemented. Figure 3(a) shows the connection of an inductor in series with the line filter inductor for each phase of the proposed system. However, it has a limited effect on the circulating current reduction process. Another approach proposes the use of magnetic coupling among the inductors, in order to suppress the cross-circulating current between the parallel interleaved phases. This connection is shown in Fig.3(b) [14], and it will be used in this paper.

A. Considerations of Coupled Inductor

Using the model of the system with coupled inductors shown in Fig.3(b), the voltage-current relations are obtained through electromagnetic analysis. In this paper, core and copper losses, and leakage flux are neglected [15]. From the models given in Fig.4 and Fig.5, the phase voltage is defined as follows:

$$v_{1x} = L \frac{di_1}{dt} - L \frac{di_2}{dt} \quad (4)$$

$$v_{2x} = L \frac{di_2}{dt} - L \frac{di_1}{dt} \quad (5)$$

And the phase current is equivalent to:

$$i_x = i_1 + i_2 \quad (6)$$

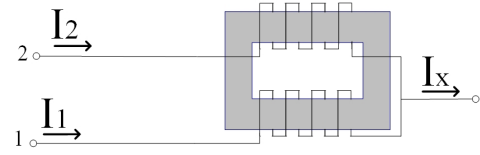

Figure 4: Coupled inductor structure

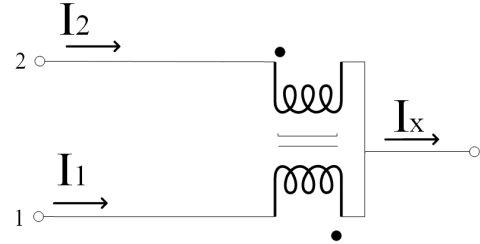

Figure 5: Coupled inductor model

Where L is the self-inductance of a core-leg. The above equations are further rewritten as:

$$v_{1x} = 2L \frac{di_1}{dt} - L \frac{di_x}{dt} \quad (7)$$

$$v_{2x} = 2L \frac{di_2}{dt} - L \frac{di_x}{dt} \quad (8)$$

It is also possible to decompose the currents into the common and differential modes. The differential mode current is given in (3) and is equal to the cross-circulating current, whereas the common mode current is defined as follows:

$$i_c = \frac{i_1 + i_2}{2} \quad (9)$$

Alternatively, the cross-circulating current is defined as:

$$i_{d1} = i_1 - i_c = -i_{zx} \quad (10)$$

$$i_{d2} = i_2 - i_c = i_{zx} \quad (11)$$

Using (10) and (11) it is possible to obtain:

$$v_{1x} = 2L \frac{di_{d1}}{dt} \quad (12)$$

$$v_{2x} = 2L \frac{di_{d2}}{dt} \quad (13)$$

Equations (12) and (13) demonstrate that the coupled inductors do not provide any inductance for the common mode current, but provide the effect of L for the differential mode. In other words, the coupled inductors can be used to suppress the cross-circulating current among the parallel branches.

IV. CONTROL AND MODULATION STRATEGY

The main objective of this work is to develop a simple control method for the proposed system. This is done to avoid the implementation of dedicated control loops for the internal balance of the capacitor voltages of the MMSPC modules, and other for reducing the cross-circulating current. Therefore, as presented in Fig.6, the proposed control scheme is based on

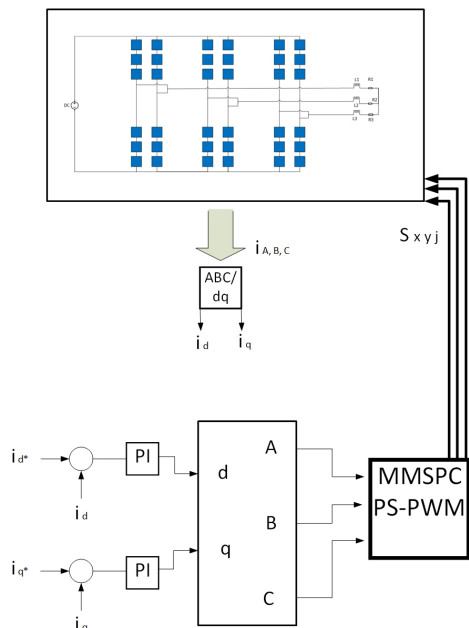

Figure 6: Proposed control scheme

simple loops that regulate the dq current components of the load, by the means of linear PI controllers.

To achieve the internal voltage balance between the N modules that are connected in series within an arm of the converter, MMSPC-type modules will be used. These modules allow access to both sides of the capacitor to achieve a parallel interconnection between neighboring cells for certain switching states. Also, the remaining switching states permit to connect the neighboring module in either series, anti-series or bypass.

If the MMSPC modules of the same phase are connected in series (anti-series), the phase output voltage will increase (decrease) in one level. However, if the modules are connected in parallel, the phase output voltage is maintained at the same level, but the parallel connection of two adjacent MMSPC modules generates charge-balancing currents, which allows restoring the voltage balance between the MMSPC modules without the implementation of control algorithms or extra voltage/current sensors [16].

However, to achieve this operation, the modulation strategy of each phase must ensure that the parallel state is implemented the maximum number of times that are possible, and the interval between leveling by parallelization should be kept short, so that it reduces the balancing losses [13]. In specific, the phase-shift pulse width modulation (PS-PWM) framework is implemented in this work [16].

In this way, the system is internally balanced without the need for control loops or additional sensors. In the next section, the effects of considering coupled or separate inductors will be analyzed through simulations, to achieve the minimum cross-circulating current without the need for additional control strategies.

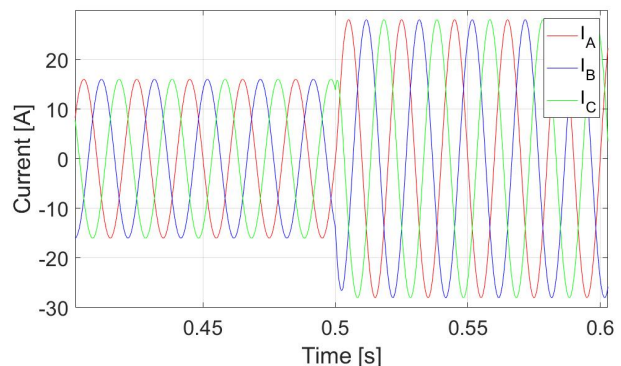

Figure 7: Output current i_x

V. SIMULATION RESULTS

The parameters of the simulation are indicated in Table I. The first test validates the correct control of the output current i_x . To achieve this, the current reference of the d -axis component is changed from $i_d = 16$ A to $i_d = 28$ A at $t = 0.5$ s. As presented in Fig. 7, the output current i_x has a perfect balance and good quality, due to the multilevel voltage waveform enabled by the proposed system.

Table I: Simulation Parameters

Parameter	Value
DC voltage system V_{DC}	1.5 kV
Carrier frequency of modulation framework	4.5 kHz
Arm Inductance L_{xy}	20 mH
Arm Resistance R_{xy}	0.1 Ω
Load Resistance R_x	20 Ω
Load Inductance L_x	15 mH
AC output frequency	50 Hz
DC module voltage v_{dc}	500 V
Inductance L_1	16.5 mH
Inductance L_2	13.5 mH
Filter resistance R_1	0.1 Ω
Filter resistance R_2	0.1 Ω

A. Internal Cross-Circulating Current

Then, to study the effects of parameter mismatches in the converter, the inductances L_1 and L_2 are simulated with a difference of 10% as shown in Table I. This difference produces an effect in the cross-circulating current. Depending on the connection of the inductors, it is possible to obtain a different effect on the cross-circulating current. In the first approach, the resulting cross-circulating current presented in Fig.8 is analyzed for the system with separate inductors (see Fig.3(a)). In this case, the peak value of the cross-circulating current reaches 2 A approximately. On the other hand, the same system is evaluated with coupled inductors as shown in Fig.3(b). It can be seen that this approach leads to a 30% reduction in the cross-circulating current amplitude as shown

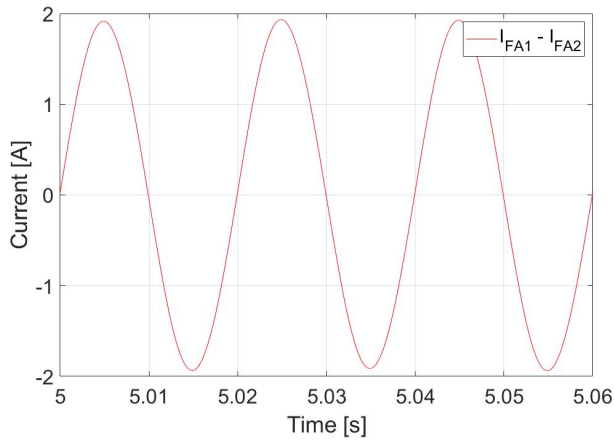

Figure 8: Cross-circulating current with separate inductors

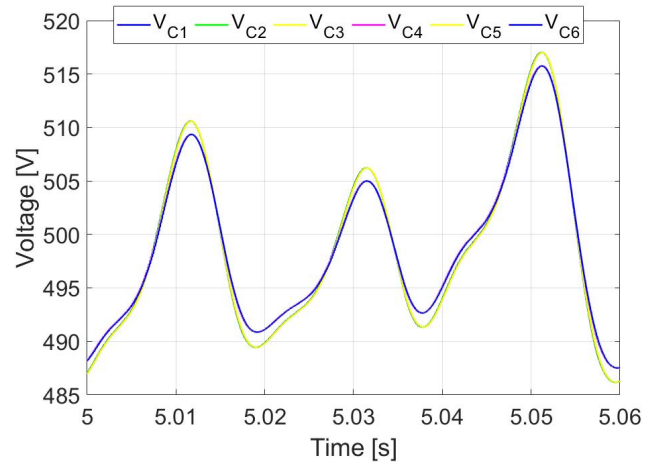

Figure 10: Modules capacitor voltages with separate inductors

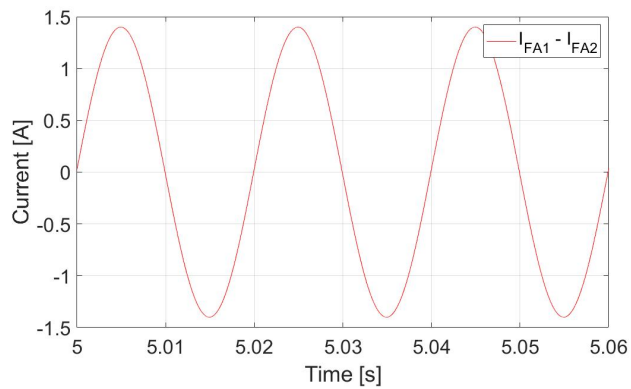

Figure 9: Cross-circulating current with coupled inductors

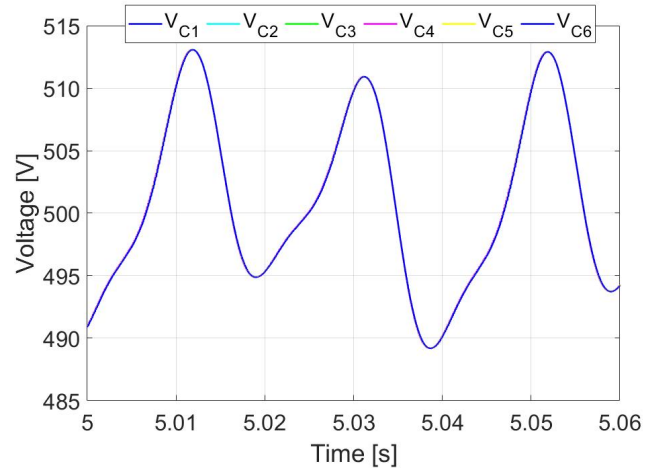

Figure 11: Modules capacitor voltages with coupled inductors

in Fig.9. dropping to 1.4 A, hence leading to a reduction of the internal losses as well.

B. Modules capacitor voltages

The use of MMSPC modules allows the balance of the module capacitor voltages as illustrated in Fig.10 and Fig.11. It is observed that the capacitor voltage of each module is balanced around 500 V, regardless whether the system uses separate or coupled inductors. It can be seen that the internal voltage balance is achieved without any dedicated control stages or extra sensors. Then, since the converter has $N = 3$ cells per arm, the 1.5 kV voltage in the DC port is equally shared by them.

C. Modules capacitor voltage difference

The reduction in the cross-circulating current allows also a reduction in the voltage difference among the modules of the same arm. To corroborate this, the voltage difference of the modules of the same arm is presented in Fig.12 and Fig.13. It is observed that in Fig.12, the voltage difference with separate inductors has a peak value equal to $\Delta v = 2.3V$. However, in Fig.13 the voltage difference with coupled inductors is equal to $\Delta v = 0.25 mV$. This result validates the reduction in

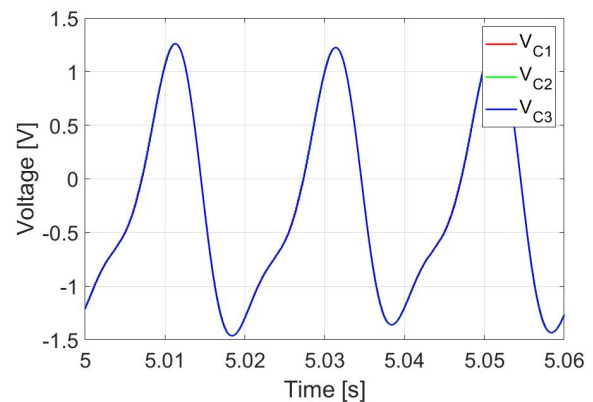

Figure 12: Voltage difference with separate inductors

the internal losses of the system and the improvement in the performance of the proposed system when a coupled inductor is considered for the interconnection of parallel phases.

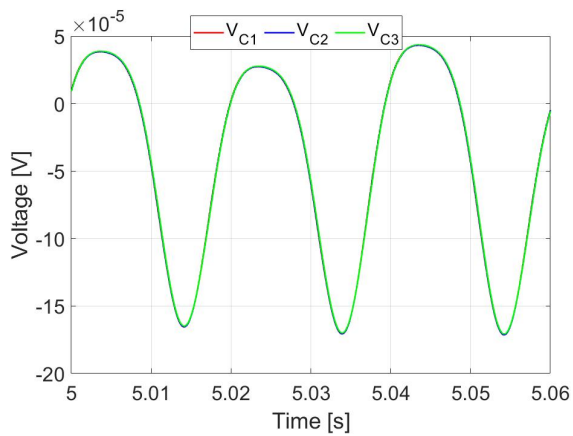

Figure 13: Voltage difference with coupled inductors

VI. CONCLUSIONS

This paper proposed a modular multilevel series-parallel converter (MMSPC) with parallel-connected phases and coupled inductors for high-current applications. The use of MMSPC modules in each arm of the proposed system allows the internal voltage balance of each arm in a simple and direct strategy, without any extra sensor or control loop in order to achieve a reduction in size and cost of the implementation. On the other hand, to achieve the operation of the proposed system in high-current applications; the proposed system is implemented with phases connected in parallel. Thereby, the load current is divided into a number of phases that are connected in parallel.

In this way, it is possible to identify the effects of the cross-circulating current, which causes an increase in internal losses and reduces the performance of the proposed system. In order to reduce the effects of this current, a coupled inductor is proposed. Although decoupled inductors have the advantage that if one fails, it can be more easily replaced, they don't have significant effects on reducing circulating current compared to coupled inductors.

When contrasting the obtained results, it is observed that the use of coupled inductors reduces the cross-circulating current by 30%, even under parameter mismatch. This reduction in the cross-circulating current significantly diminishes the imbalance between the voltages of the capacitors in the modules of the same phase. The voltage difference decreases from 2.3 V with decoupled inductors to 0.25 mV when using coupled inductors. The proposed system also shows superior performance under current control only and maintains the internal voltage balance among the modules without extra sensors or control strategies. Moreover, the use of coupled inductors reduces the cross-circulating current and allows the operation of the system under parameter mismatches.

VII. ACKNOWLEDGMENT

This work was supported by the following projects from the Agencia Nacional de Investigación y Desarrollo (ANID): FONDECYT-R Grant No. 1230306, REDES-PCI

190108, AC3E (ANID/Basal/FB0008), Fondo de Actividades Académicas FAA-UCSC, Centro de Energía UCSC and SERC Chile (ANID/FONDAP/1522A0006).

REFERENCES

- [1] J. Rodríguez, S. Bernet, B. Wu, J. O. Pontt, and S. Kouro, "Multilevel Voltage-Source-Converter Topologies for Industrial Medium-Voltage Drives," *IEEE Trans. Ind. Electron.*, vol. 54, no. 6, pp. 2930–2945, Dec 2007.
- [2] S. Kouro, M. Malinowski, K. Gopakumar, J. Pou, L. G. Franquelo, B. Wu, J. Rodríguez, M. A. Perez, and J. I. Leon, "Recent Advances and Industrial Applications of Multilevel Converters," *IEEE Trans. Ind. Electron.*, vol. 57, no. 8, pp. 2553–2580, Aug 2010.
- [3] L. G. Franquelo, J. Rodríguez, J. I. Leon, S. Kouro, R. Portillo, and M. A. M. Prats, "The Age of Multilevel Converters Arrives," *IEEE Ind. Electron. Mag.*, vol. 2, no. 2, pp. 28–39, June 2008.
- [4] A. Dekka, B. Wu, R. L. Fuentes, M. Perez, and N. R. Zargari, "Evolution of Topologies, Modeling, Control Schemes, and Applications of Modular Multilevel Converters," *IEEE Trans. Emerg. Sel. Topics Power Electron.*, vol. 5, no. 4, pp. 1631–1656, Dec 2017.
- [5] M. A. Perez, S. Bernet, J. Rodríguez, S. Kouro, and R. Lizana, "Circuit Topologies, Modeling, Control Schemes, and Applications of Modular Multilevel Converters," *IEEE Trans. Power Electron.*, vol. 30, no. 1, pp. 4–17, Jan 2015.
- [6] S. M. Goetz, A. V. Peterchev, and T. Weyh, "Modular multilevel converter with series and parallel module connectivity: Topology and control," *IEEE Transactions on Power Electronics*, vol. 30, no. 1, pp. 203–215, Jan 2015.
- [7] F. Helling, S. Götz, A. Singer, and T. Weyh, "Fast modular multilevel series/parallel converter for direct-drive gas turbines," in *2015 IEEE NW Russia Young Researchers in Electrical and Electronic Engineering Conference (EIconRusNW)*, Feb 2015, pp. 198–202.
- [8] C. Wang, Z. Li, D. L. K. Murphy, Z. Li, A. V. Peterchev, and S. M. Goetz, "Photovoltaic Multilevel Inverter with Distributed Maximum Power Point Tracking and Dynamic Circuit Reconfiguration," in *2017 IEEE 3rd International Future Energy Electronics Conference and ECCE Asia (IFEEC 2017 - ECCE Asia)*, June 2017, pp. 1520–1525.
- [9] S. M. Goetz, Z. Li, X. Liang, C. Zhang, S. M. Lukic, and A. V. Peterchev, "Control of Modular Multilevel Converter With Parallel Connectivity - Application to Battery Systems," *IEEE Trans. Power Electron.*, vol. 32, no. 11, pp. 8381–8392, Nov 2017.
- [10] R. L. F., S. Rivera, Z. Li, J. Luo, A. V. Peterchev, and S. M. Goetz, "Modular multilevel series/parallel converter with switched-inductor energy transfer between modules," *IEEE Transactions on Power Electronics*, vol. 34, no. 5, pp. 4844–4852, 2019.
- [11] D. Verdugo, J. Lillo, F. Rojas, M. Azharuddin, and J. Pereda, "Capacitor balance control of a modular multilevel converter based on parallel connected branches for a mvac/lvdc solid state transformer," in *2021 IEEE 22nd Workshop on Control and Modelling of Power Electronics (COMPEL)*, 2021, pp. 1–7.
- [12] S. M. Goetz, A. V. Peterchev, and T. Weyh, "Modular Multilevel Converter With Series and Parallel Module Connectivity: Topology and Control," *IEEE Trans. Power Electron.*, vol. 30, no. 1, pp. 203–215, Jan 2015.
- [13] H. Bahamonde I., S. Rivera, Z. Li, S. Goetz, A. Peterchev, and R. Lizana F., "Different parallel connections generated by the modular multilevel series/parallel converter: an overview," in *IECON 2019 - 45th Annual Conference of the IEEE Industrial Electronics Society*, vol. 1, 2019, pp. 6114–6119.
- [14] G. Gohil, L. Bede, R. Teodorescu, T. Kerekes, and F. Blaabjerg, "An integrated inductor for parallel interleaved vscs and pwm schemes for flux minimization," *IEEE Transactions on Industrial Electronics*, vol. 62, no. 12, pp. 7534–7546, 2015.
- [15] I. G. Park and S. I. Kim, "Modeling and analysis of multi-interphase transformers for connecting power converters in parallel," in *PESC97. Record 28th Annual IEEE Power Electronics Specialists Conference. Formerly Power Conditioning Specialists Conference 1970-71. Power Processing and Electronic Specialists Conference 1972*, vol. 2, 1997, pp. 1164–1170 vol.2.
- [16] M. Correa, S. Rivera, and R. L. F., "Hybrid energy storage system based on modular multilevel series parallel converter," in *IECON 2022 - 48th Annual Conference of the IEEE Industrial Electronics Society*, 2022, pp. 1–5.