



Delft University of Technology

Strategic Planning of Reconfigurable Industrial Systems and Value Chains A life cycle conceptual model

Napoleone, Alessia

DOI

[10.1016/j.procir.2024.01.145](https://doi.org/10.1016/j.procir.2024.01.145)

Publication date

2024

Document Version

Final published version

Published in

Procedia CIRP

Citation (APA)

Napoleone, A. (2024). Strategic Planning of Reconfigurable Industrial Systems and Value Chains: A life cycle conceptual model. *Procedia CIRP*, 122, 1071-1076. <https://doi.org/10.1016/j.procir.2024.01.145>

Important note

To cite this publication, please use the final published version (if applicable).
Please check the document version above.

Copyright

Other than for strictly personal use, it is not permitted to download, forward or distribute the text or part of it, without the consent of the author(s) and/or copyright holder(s), unless the work is under an open content license such as Creative Commons.

Takedown policy

Please contact us and provide details if you believe this document breaches copyrights.
We will remove access to the work immediately and investigate your claim.

31st CIRP Conference on Life Cycle Engineering (LCE 2024)

Strategic Planning of Reconfigurable Industrial Systems and Value Chains: A life cycle conceptual model

Alessia Napoleone^{a,*}

^a*Delft University of Technology, Mekelweg 2, Delft 2628 CD, The Netherlands*

* Corresponding author. Tel.: +31-681-789-804 E-mail address: a.napoleone@tudelft.nl

Abstract

Strategic planning of industrial systems has become increasingly challenging for decision makers at different production levels, due to several aspects, such as global competition, market uncertainty and volatility, and changing regulations. These evolving aspects often lead to unplanned and high-effort reconfigurations of systems. Additionally, high-paced innovation in industrial technologies and the diffusion of software, data analytics, and big data technologies in industrial systems, while potentially supporting ever smarter, safer, and greener decisions, also challenge decision makers, as often multi-disciplinary knowledge is required to successfully plan and operate increasingly complex systems. Existing literature provides little guidance on how strategic planning of industrial systems is expected to evolve in order to fully exploit advanced industrial technologies to responsively and cost effectively respond to global challenges. To fill this gap, this paper reviews existing literature on industrial systems' planning and reconfigurability and derives multi-sectorial requirements. Based on the findings, a life cycle conceptual model for strategic planning of reconfigurable industrial systems and value chains is provided. Moreover, the concepts of hierarchical interfaces, functional interfaces, and reconfigurability bottleneck are introduced and directions for future research are accordingly outlined.

© 2024 The Authors. Published by Elsevier B.V.

This is an open access article under the CC BY-NC-ND license (<https://creativecommons.org/licenses/by-nc-nd/4.0>)

Peer-review under responsibility of the scientific committee of the 31st CIRP Conference on Life Cycle Engineering (LCE 2024)

Keywords: strategic planning, life cycle planning, reconfigurable manufacturing systems, circularity, sustainability;

1. Introduction

Uncertainty and complexity challenge industrial decision makers. As unpredictability and volatility of market requirements grow, worldwide industries experience reduction in product lifecycles, increased variety, and higher product complexity. These changes often trigger high-effort reconfigurations that negatively affect performances over time, leading to, for example, reduced efficiency, quality or reliability of the system. Global pressures towards sustainability goals, changing regulations, resource exhaustion/unavailability, and geo-political challenges also require often unplanned and costly reconfigurations in products, processes, and technologies that also affect systems' performances. Furthermore, rapid innovation in industrial and smart technologies and the diffusion of software, data analytics, and big data technologies in industrial systems

require decision makers to possess a combination of technical and managerial expertise to interact with complex cyber-physical systems and implement the right decisions.

As uncertainty and complexity grow, the reconfigurability capability – that is the capability of an industrial system to quickly and cost-effectively adapt to changes - is needed. The reconfigurability capability is a strategic life-cycle capability that requires implementing flexible and reconfigurable systems and technologies to rapidly adapt manufacturing and logistics capabilities to market and technological evolution. To fully develop this capability, the strategic process of planning industrial systems need reconsideration. While several flexible and reconfigurable technologies and systems have been researched and matured over time (e.g., reconfigurable machine tools, advanced robotic systems, adaptive control systems), the development of new solutions for strategic planning of these

systems still requires research efforts. To investigate this gap, this paper aims to outline how industrial system's planning is expected to change in order to enable higher levels of reconfigurability. To this end, section 2 describes industrial system's planning modules and related challenges. Section 3 reviews literature and outlines multi-sectorial requirements for system's planning. Section 4 introduces a conceptual model for strategic planning of reconfigurable industrial systems and value chains. Accordingly, the concepts of hierarchical interfaces, functional interfaces, and reconfigurability bottleneck are introduced to outline directions for future research. Section 5 concludes and outlines future research directions.

2. Industrial planning systems

Industrial systems manufacture, assemble, and/or transport products along value chains and therefore play a significant role in national and global economies,

Industrial planning systems support the design and coordination of manufacturing resources, equipment and materials flows in order to accommodate market requirements. Consequently, planning systems require different stakeholders, technical and managerial knowledge, and life cycle assessments. To address this complexity, a planning system can be broken down into the following modules:

- process design (A), this module has strategic and long-term implications as it determines both system's configuration and equipment development based on long-term market trends. It constraints system's performance in the long-term and can lead to capital expenditures, outsourcing, change management or, introduction of organizational or procedures. Success criteria strictly depend on the system's strategy and can generally be assessed only in the long-term.
- process planning and scheduling (B), this module has tactical and mid-term implications as it ensures that the system is able to successfully deliver the required products to customers based on mid-term forecast and/or customer orders. It usually requires clustering material flows based on process and/or customer constraints, and leads to the definition of plans and schedules for the required tasks that optimize one or more success criteria. Success criteria for this stage can be either process-driven (e.g. productivity, efficiency, utilization, lead time, ...) and/or supply-driven (e.g. takt time, dependability, quality,...) and depend on system's configuration and materials flows complexity.
- process control (C), this module has operational and short-term implications as it ensures that the system promptly reacts to internal i.e. process-driven (e.g., equipment failure, rework, scrap, workforce availability,...) and/or external i.e. supply-driven (e.g., materials shortage, supply/delivery delays, ...) disruptions and contingencies.

In a stable and highly predictable environment, modules A and B are sequential steps and module C is unnecessary. In this ideal scenario, the structure of the system is only determined at the beginning of the system's life cycle through module A, and it therefore affects once and for all module B. This also means that in this ideal scenario, decision logics of module B will not change over time and module B can potentially be fully

automated as the actual execution of tasks will exactly follow plans and schedules.

Worldwide, increasing uncertainty about market evolution and global trends makes system's planning extremely challenging. On the one hand, the structure of the system needs frequent adaptations to changes, and thus module A is repeatedly implemented within the system's life cycle, and therefore it dynamically constraint and requires changes in module B. On the other hand, process- and supply- related disruptions and contingencies make module C extremely relevant: describing the actual execution of tasks in spite of plans and schedules, it leads to changes in process planning and scheduling (B), for example in a production environment where internal disruptions (e.g. rework) are frequent.

Fig. 1 summarizes industrial system's planning modules and interfaces in uncertain scenarios.

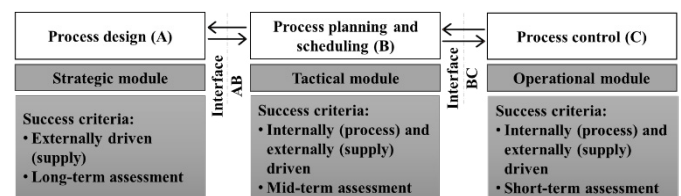

Fig. 1. Industrial system's planning modules and interfaces in uncertain scenarios

As detailed in Section 3, to identify multi-sectorial requirements for planning systems in uncertain scenario, the literature analysis also considered the system's level of detail, distinguishing between: workstation, system, company, and supply chain levels.

3. Literature review

A literature search was conducted in Scopus, combining the keywords "reconfigurability" and "planning" and overall 192 papers were reached. Among these 68 were excluded, as: (i) 59 were not related to the manufacturing industry, and (ii) 9 were not related to planning solutions. The remaining sample of 124 papers was analysed and classified according to the production level, distinguishing between: workstation, system, company, and supply chain.

In the literature at the workstation level (30 articles), the following types of systems were considered: (i) machining (in five articles, i.e. 17%), and (ii) robotic (in 25 articles, i.e. 83%). In the machining domain (five articles), literature mainly addressed process design (A) for reconfigurability. For example, [1] provided a methodology of setting module groups for the design of reconfigurable machine tools; while, [2] focused on machine fixture design. Three studies in this domain focused on both process design (A) and process planning (B). For example, [3] developed a transformable pin array fixture system including reconfiguration planning software that finds the optimal position for mounting an assembly part and automatically generates a pin height control code. In the robotic domain (25 articles), literature mainly addressed process design (A) and process control (C). Specifically, process design was combined with mechanisms for: (i) robot fault control in one article [4]; (ii) grasp or motion planning and control in six articles (e.g., [5,6]); path planning and control in six articles

(e.g., [7,8]), and shopfloor data integration for robot control in three articles (e.g., [9,10]).

In the literature at the system level (67 articles), the following types of systems were considered: (i) mixed, i.e. with both humans and robots or machines (in 48 articles, i.e. 72%), or (ii) robotic (in 19 articles, i.e. 28%). In the mixed domain, i.e. systems with both humans and robots or machines (48 articles), two types of systems were mainly referred to, i.e. production (23 articles), and assembly (13 articles). Overall, only three articles looked at process (specifically production) control (C), in terms of implementation of agent/holon technologies for distributed automation [13,14], or for diagnostic purposes [15]. The other articles focused on several themes, such as scheduling of production [16], assembly [17], or material handling [18] systems, software design for system automation [18–22], shopfloor data integration for production [23] or assembly [24] control. In the robotic domain (19 articles), literature was fairly distributed around: process design (A), process planning (B), and process control (C). Of these, process control was the prevailing theme, and five articles within this set specifically focused on motion planning (e.g., [11,12]).

In the literature at the company level (18 articles), the following types of systems were considered: (i) human (four articles), (ii) mixed (10 articles), or (iii) automated (four articles). In the human domain, prevailing themes were: business and plant planning [25], and workforce planning [26–28]. In the mixed domain, prevailing themes were: business and plant planning [33,34], IT architecture design [35–40], resources' connectivity [41] and functional architecture [42]. In the automated domain, prevailing themes were: factory control [29], factory ramp-up [30], warehouse control [31], and IT architecture design [32].

In the literature at the supply chain level (nine articles), the following types of systems were considered: (i) business (three articles), plant (two articles), or (iii) mixed, i.e. plants and vehicles (four articles). In the business domain, literature focused on collaborative planning in terms of data-sharing methods [43] and tools [44], and business models [45]. In the plant domain, literature addressed factory and network planning [45,46]. In the mixed domain, prevailing themes were: factory location [47,48] and/or transport planning [49], and factory and transport coordination and scheduling [50].

The literature review process led to the identification of multi-sectorial requirements for strategic planning of reconfigurable industrial system as summarized in Table 1 and described as follows:

- At the workstation level, reconfigurability planning modules are: (A) process technology design, (B) process life cycle planning, and (C) task automation;
- At the system level, reconfigurability planning modules are: (A) layout and configuration design, (B) system life cycle planning, and (C) system monitoring and control;
- At the company level, reconfigurability planning modules are: (A) business planning and change management, (B) plant life cycle planning, and (C) IT architecture and factory control;
- At the supply chain level, reconfigurability planning modules are: (A) collaborative business design, and (B) product life cycle planning.

A relevant insight from the literature analysis is that only a small subset of the analysed literature (15 out of 124 articles) provided planning solutions at multiple levels. Seven focused at workstation and system levels, five at system and company levels, and three at company and supply chain levels. Four were published after 2020, while two were published before 2005. Nearly all these articles proposed collaboration and/or coordination solutions enabled with digital and smart technologies. Specifically:

- Six articles described enablers of collaboration. Of these: two focused on collaboration between different workstations enabled with collaborative [51] or mobile robot [52] technologies; three focused on collaboration between different systems enabled with communication capabilities based on radio access [34] technology, Internet of Things [40], or edge and cloud [38] technologies; one focused on collaboration between different plants enabled with cyber-physical systems [45] technologies.
- Six articles described enablers of coordination. Of these: five focused on coordination of workstations enabled with topology network [53], holon/agent-based [54], Artificial Intelligence [55], intelligent mechatronics components [56] or Internet of Things [57] technologies; only one focused

Table 1. Literature analysis and findings. From prevailing literature themes to multi-sectorial requirements for strategic planning of industrial systems at workstation (WS), system (S), company (C), and supply chain (SC) levels

Industrial system	Planning module	Prevailing themes	Multi-sectorial requirements
WS	Machining	A, B A. Modular machine design, Fixture and tooling design B. Modular machine design, Fixture and tooling design	A. Process technology design B. Process lifecycle planning C. Task automation
	Robotic	A, C C. Fault control, grasp/ motion planning, path planning and control, shopfloor data integration	
S	Mixed	A, B A. Production/assembly/handling system planning B. Production/assembly/handling scheduling, line balancing, production system ramp-up	A. Layout and configuration design B. System lifecycle planning C. System monitoring and control
	Robotic	A, B, C C. Process control and motion planning, software design and shopfloor data integration	
C	Human	A, B A. Business and plant planning, workforce planning	A. Business planning, change management
	Mixed	A, B, C B. Functional architecture design, plant ramp-up	B. Plant lifecycle planning
	Automated	C C. Resource connectivity design, IT architecture design, factory control, warehouse control	C. IT architecture and plant control
SC	Business	A, B A. Collaborative business model design, plant location and supply/distribution planning	A. Collaborative business design
	Plant (2)	A, B B. Transport planning, plant and transport coordination and scheduling	B. Network lifecycle planning
	Mixed (4)	A, B	

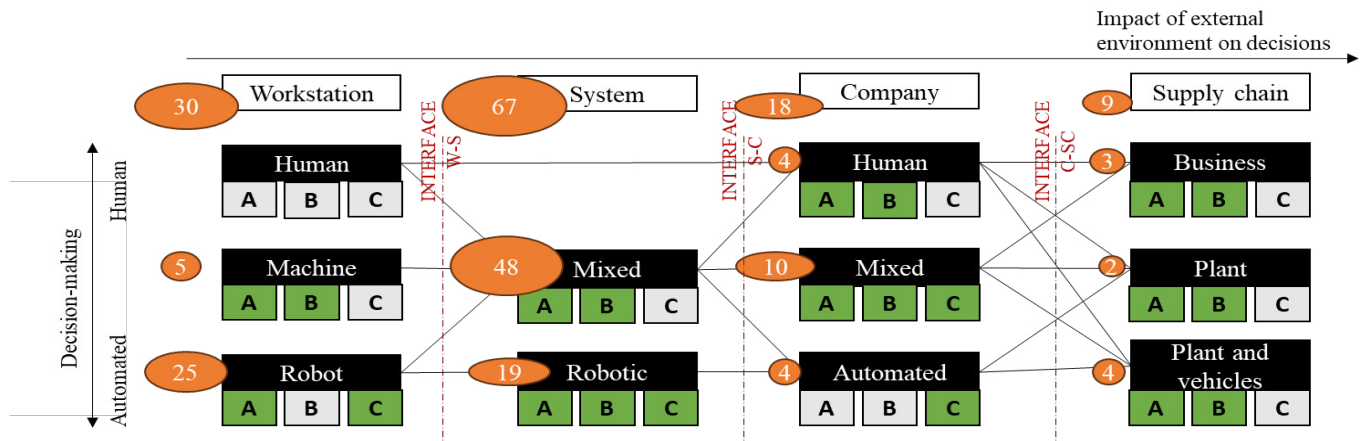

Fig. 2. A conceptual model for strategic planning of reconfigurable industrial systems and value chains

on coordination of systems enabled with the web service technology [37].

- Finally, two papers described enablers of both collaboration and coordination. In 2003, [58] proposed workflow automation for collaboration and coordination of different businesses within a supply chain, in 2023, [39] referred to Artificial Intelligence and MES technologies for collaboration and coordination of different resources within a company.

4. A conceptual model for strategic planning of industrial systems and value chains

A conceptual model for strategic planning of industrial systems and value chains is provided in Fig. 2. This framework allows to introduce the concepts of hierarchical interfaces, functional interfaces, and reconfigurability bottleneck to outline directions for future research. These concepts are all relevant for strategic planning in several industries.

The conceptual model shows four hierarchical interfaces between production levels, and, at each production level, functional interfaces between planning modules can also be identified. Both hierarchical and functional interfaces represent cause-effect relationships: hierarchical, i.e. between functions at different production levels, and time-based, i.e. between functions over time. Obviously, functions at lower levels are contained in higher levels, and goals at higher levels can be broken down to sub-goals at lower levels. As requirements change over time, time is also a relevant variable. Thus, the stages of the system's life cycle are considered.

Hierarchical interfaces are the interfaces between planning systems at different production levels, namely W-S, S-C and C-SC in Fig. 2. Through hierarchical interfaces, the decision maker can set values and reconfigurability goals for a system and the related sub-systems based on the external environment.

Functional interfaces are the interfaces between planning modules within each production level, namely A-B, B-C, C-D in Fig. 1. Through functional interfaces, the decision makers adopt a life cycle perspective to identify new functional requirements for the system as a whole and then reassesses the sub-functions needed at the lower level, identifies functional

gaps and consequently investigate technological and managerial solutions to address reconfigurability bottlenecks.

A reconfigurability bottleneck is any component of an industrial system that at a certain time prevents the system from implementing a higher-value lower-effort reconfiguration. To identify reconfigurability bottlenecks, hierarchical and functional interfaces for strategic planning of reconfigurable industrial systems and value chains need to be developed first.

In Fig. 2, both the type of system and system planning modules at each production level are classified as per the literature review. Depending on type of system the impact of humans on decision making changes as also shown in Fig. 2. Whenever planning modules (either A, B, and/or C) are represented as green blocks instead of gray blocks, it means that at least one article covered one or more themes in the related module. More in detail:

- 78% of the analysed literature focused at workstation (24%, i.e. 30 articles) and system (54%, i.e. 67 articles) levels. At the workstation level, literature mostly addressed themes within robotic tasks' planning, introducing requirements for process technology design (A) and task automation (C). At system level, literature mostly addressed themes within mixed system's layout and configuration design (A) and system's lifecycle planning (B).
- Only 15% of the analysed literature focused at company level. In this sample, the impact of human on decision-making was significantly higher than the impact of automation (56% of the literature at company level referred to human systems, 31% referred to mixed, and 13% referred to automated systems). In contrast, at workstation and system levels decision-making was mainly embedded in automation. Prevailing themes in this sample introduced requirements within business planning and change management (A), and plant lifecycle management (B).
- A small percentage (7%) of the analysed literature focused at supply chain level. In this sample, the impact of human and automation on decision-making was rather balanced. Prevailing themes provided requirements within collaborative business design (A), and product life cycle management (B).

From left to right, Fig. 2 also highlights how the managerial effort required for a system's reconfiguration

increases at higher production level, while the technical effort reduces at higher levels. For example, workstation planning can be challenging due to technological complexity which can be very technology-specific, while, supply chain planning has managerial complexity due to the involvement of multiple stakeholders and industries. Additionally, Fig. 2 shows that research at higher production levels is rather scarce compared to research at workstation and system levels (78% of the sample), thus confirming that industrial system's planning for reconfigurability is still an open topic especially at company and supply chain levels.

Ultimately, Fig. 2 shows that the impact of the external environment, such as global sustainability challenges, on decisions increases with the extension of the production level. Indeed, even if the information detail needed for decision making is reduced moving from lower to higher production levels, a broader variety of information will progressively need consideration.

5. Conclusion

As uncertainty and complexity grow, industrial decision makers are urged to reconsider traditional planning systems and to leverage on advanced and smart technologies to plan for and react to market, economic, social and technological evolution. This paper introduces a representation of the life-cycle planning of reconfigurable industrial systems and value chains, together with the concepts of reconfigurability bottleneck, hierarchical, and functional interfaces in a conceptual model. Thus, this study contributes to the discipline of system's life-cycle engineering.

In the proposed model, relevant decision levels for types of industrial systems, related planning modules, and cause-effect relations between these are represented. For instance, the model shows that a decision to improve circularity at supply chain level (cause-), will constraint the systems at lower levels (i.e. the factories, warehouses, and logistics facilities that form a value chain's configuration) and will require them to make adjustments (effect). To this end, the model introduces the concept of hierarchical interfaces. Moreover, at each decision level, the planning modules (i.e. A, B, C) will implement the strategy over the system's lifecycle and will interact with each other over time due to uncertainties. In the aforementioned example, a value chain might need to redefine a circularity strategy (effect) based on the feedback received from operational modules (cause), or due to new regulations (cause). To this end, the model introduces the concept of functional interfaces.

This study also shows that as uncertainty and complexity grow, hierarchical and functional interfaces deserve further investigation. In future research the author will aim to further develop these concepts, and to formalize requirements for decision support tools and methods for strategic planning in uncertain scenarios. This will be combined with case studies in relevant industries (e.g. the metal value chain). Future research will primarily focus on sustainability as critical external driver for change in industrial systems, this will ultimately support industrial decision makers to identify reconfigurability bottlenecks in relation to sustainability goals.

Future research will particularly aim to apply the proposed model in Dutch and European industries to support competitiveness and sustainability.

References

- [1] Wang Y, Zhang G, Han L. A methodology of setting module groups for the design of reconfigurable machine tools. *International Journal of Advanced Manufacturing Technology* 2019;104:2133–47. <https://doi.org/10.1007/s00170-019-03337-6>.
- [2] Li W, Li P, Rong Y. Case-based agile fixture design. *High Technology Letters* 2001;7:70–4.
- [3] Park JW, Park J, Kim H, Kim N, Kim DY. Assembly Part Positioning on Transformable Pin Array Fixture by Active Pin Maximization and Joining Point Alignment. *IEEE Transactions on Automation Science and Engineering* 2022;19:1047–57. <https://doi.org/10.1109/TASE.2021.3050403>.
- [4] Raman A, Walker I, Krovi V, Schmid M. Cable failure tolerant control and planning in a planar reconfigurable cable driven parallel robot. *Frontiers in Robotics and AI* 2023;10. <https://doi.org/10.3389/frobt.2023.1070627>.
- [5] Emmanouil E, Zhang K, Dai JS. Control strategy and trajectory planning for reconfiguration of a vA based metamorphic parallel manipulator. vol. 6 B, 2013. <https://doi.org/10.1115/DETC2013-12445>.
- [6] Jarrault P, Grand C, Bidaud P. Obstacle crossing with the wheel-legged robot hyllos based on a robustness criterion on the frictional contacts, 2012, p. 676–83.
- [7] Cheng KP, Mohan RE, Khanh Nhan NH, Le AV. Multi-Objective Genetic Algorithm-Based Autonomous Path Planning for Hinged-Tetro Reconfigurable Tiling Robot. *IEEE Access* 2020;8:121267–84. <https://doi.org/10.1109/ACCESS.2020.3006579>.
- [8] Rasheed T, Long P, Marquez-Gamez D, Caro S. Path planning of a mobile cable-driven parallel robot in a constrained environment. vol. 74, 2019, p. 257–68. https://doi.org/10.1007/978-3-030-20751-9_22.
- [9] Reji AT, Dogra A, Jha SS, Singla E. Task Space Reconstruction in Modular Reconfigurable Manipulation System, 2021, p. 565–74. https://doi.org/10.1007/978-981-16-1769-0_51.
- [10] Hang K, Bircher WG, Morgan AS, Dollar AM. Hand-object configuration estimation using particle filters for dexterous in-hand manipulation. *International Journal of Robotics Research* 2020;39:1760–74. <https://doi.org/10.1177/0278364919883343>.
- [11] Vrohidis C, Bechlioulis CP, Kyriakopoulos KJ. Decentralized Reconfigurable Multi-Robot Coordination from Local Connectivity and Collision Avoidance Specifications. vol. 50, 2017, p. 15798–803. <https://doi.org/10.1016/j.ifacol.2017.08.2319>.
- [12] Yang L, Jiang J, Gao X, Wang Q, Dou Q, Zhang L. Autonomous environment-adaptive microrobot swarm navigation enabled by deep learning-based real-time distribution planning. *Nature Machine Intelligence* 2022;4:480–93. <https://doi.org/10.1038/s42256-022-00482-8>.
- [13] Rooker MN, Ebenhofer G, Strasser T. Reconfigurable control in distributed automation systems, 2009, p. 705–14.
- [14] Huang X-M, Wang Y-C, Tan D-L, Zhao M-Y. Implementation of reconfigurable production line based on agent and holon. *Dongbei Daxue Xuebao/Journal of Northeastern University* 2004;25:685–8.
- [15] Karamishev H, Stambolov G, Batchkova I, Geshev T. Distributed diagnostic and control of cutting processes based on IEC-61499. vol. 42, 2009, p. 450–5. <https://doi.org/10.3182/20090603-3-RU-2001.0481>.
- [16] Helliwell TJ, Morgan B, Vincent A, Forgeoux G, Mahfouf M. Reconfigurable Scheduling as a Discrete-Event Process: Monte Carlo Tree Search in Industrial Manufacturing, 2021, p. 151–62. <https://doi.org/10.5220/0010711600003062>.
- [17] Vahedi-Nouri B, Tavakkoli-Moghaddam R, Hanzálek Z, Dolgui A. Production scheduling in a reconfigurable manufacturing system benefiting from human-robot collaboration. *International Journal of Production Research* 2023. <https://doi.org/10.1080/00207543.2023.2173503>.
- [18] Abdi MR, Labib AW. Performance evaluation of reconfigurable manufacturing systems via holonic architecture and the analytic network process. *International Journal of Production Research* 2011;49:1319–35. <https://doi.org/10.1080/00207543.2010.520989>.

- [19] Feldmann S, Loskyll M, Rösch S, Schlick J, Zuhlke D, Vogel-Heuser B. Increasing agility in engineering and runtime of automated manufacturing systems, 2013, p. 1303–8. <https://doi.org/10.1109/ICIT.2013.6505861>.
- [20] Seilonen I, Pirttioja T, Koskinen K. Extending process automation systems with multi-agent techniques. *Engineering Applications of Artificial Intelligence* 2009;22:1056–67. <https://doi.org/10.1016/j.engappai.2008.10.007>.
- [21] Bo L, Zhenghang C, Ying C. Research on reconfigurable manufacturing execution system, 2004, p. 157–61.
- [22] Vinodrai Pandya K. Model for production planning and control decisions at cell level: a case study. *Computer Integrated Manufacturing Systems* 1994;7:75–92. [https://doi.org/10.1016/0951-5240\(94\)90002-7](https://doi.org/10.1016/0951-5240(94)90002-7).
- [23] Lei Y, Djurdjanovic D, Ni J. DeviceNet reliability assessment using physical and data link layer parameters. vol. 26, 2010, p. 703–15. <https://doi.org/10.1002/qre.1131>.
- [24] Li M, Huang GQ. Production-intralogistics synchronization of industry 4.0 flexible assembly lines under graduation intelligent manufacturing system. *International Journal of Production Economics* 2021;241. <https://doi.org/10.1016/j.ijpe.2021.108272>.
- [25] Bala H, Venkatesh V. Changes in employees' job characteristics during an enterprise system implementation: A latent growth modeling perspective. *MIS Quarterly: Management Information Systems* 2013;37:1113–40. <https://doi.org/10.25301/MISQ/2013/37.4.06>.
- [26] Sippl F, Del Rio B, Reinhart G. Approach for stakeholder identification in Manufacturing Change Management. vol. 106, 2022, p. 191–6. <https://doi.org/10.1016/j.procir.2022.02.177>.
- [27] Hussain M, Papastathopoulos A. Organizational readiness for digital financial innovation and financial resilience. *International Journal of Production Economics* 2022;243. <https://doi.org/10.1016/j.ijpe.2021.108326>.
- [28] Hashemi-Petroodi SE, Dolgui A, Kovalev S, Kovalyov MY, Thevenin S. Workforce reconfiguration strategies in manufacturing systems: a state of the art. *International Journal of Production Research* 2021;59:6721–44. <https://doi.org/10.1080/00207543.2020.1823028>.
- [29] Wood RT, Brittain CR, March-Leuba J, Mullens JA, Neal JS. Autonomous control for generation IV nuclear plants, 2004, p. 137.
- [30] Metsälä S, Gulzar K, Vyatkin V, Gröhn L, Väänänen E, Saikko L, et al. Simulation-enhanced development of industrial cyber-physical systems using OPC-UA and IEC 61499. vol. 10444 LNAI, 2017, p. 125–39. https://doi.org/10.1007/978-3-319-64635-0_10.
- [31] Basile F, Chiacchio P, Coppola J, Gerbasio D. Automated warehouse systems: A cyber-physical system perspective. vol. 2015- October, 2015. <https://doi.org/10.1109/ETFA.2015.7301597>.
- [32] Klostermeyer A, Klemm E. PABADIS an agent based flexible manufacturing concept. vol. 2003- January, 2003, p. 286–93. <https://doi.org/10.1109/INDIN.2003.1300282>.
- [33] Crawford LS, Do MB, Ruml W, Hindi H, Eldershaw C, Zhou R, et al. Online reconfigurable machines. *AI Magazine* 2013;34:73–88. <https://doi.org/10.1609/aimag.v34i3.2387>.
- [34] Dimitrakopoulos G, Bourse D, El Khazen K, Demestichas P, Saatsakis A, Luo J. Planning reconfigurable network segments: Motivation, benefits for operators and manufacturers, and strategies. vol. 3, 2005, p. 1964–8.
- [35] Colombo A-W, Karmouskos S, Mendes J-M. *Factory of the Future: A Service-oriented System of Modular, Dynamic Reconfigurable and Collaborative Systems*. Springer Series in Advanced Manufacturing, 2010, p. 459–81. https://doi.org/10.1007/978-1-84996-119-6_15.
- [36] Wang X, Zhang C, Gao X, Li Z. Development of enterprise information system using business component-based approach. *IFIP International Federation for Information Processing* 2006;205:361–9. https://doi.org/10.1007/0-387-34456-x_37.
- [37] Phaithoonbuathong P, Harrison R, West A, Monfared R, Kirkham T. Web services-based automation for the control and monitoring of production systems. *International Journal of Computer Integrated Manufacturing* 2010;23:126–45. <https://doi.org/10.1080/09511920903440313>.
- [38] Yang C, Lan S, Wang L, Shen W, Huang GGQ. Big data driven edge-cloud collaboration architecture for cloud manufacturing: A software defined perspective. *IEEE Access* 2020;8:45938–50. <https://doi.org/10.1109/ACCESS.2020.2977846>.
- [39] Vyskočil J, Douda P, Novák P, Wally B. A Digital Twin-Based Distributed Manufacturing Execution System for Industry 4.0 with AI-Powered On-The-Fly Replanning Capabilities. *Sustainability (Switzerland)* 2023;15. <https://doi.org/10.3390/su15076251>.
- [40] Faragardi HR, Fotouhi H, Nolte T, Rahmani R. A Cost Efficient Design of a Multi-sink Multi-controller WSN in a Smart Factory. vol. 2018-January, 2018, p. 594–602. <https://doi.org/10.1109/HPCC-SmartCity-DSS.2017.77>.
- [41] Luo J, Grandblaise D, Kloeck C, Dimitrakopoulos G, Moessner K. Reconfigurability impacts to resource management in future wireless communication systems. vol. 2006, 2006, p. 587–90.
- [42] Moessner K, Luo J, Mohyeldin E, Grandblaise D, Kloeck C, Martoyo I, et al. Functional architecture of end-to-end reconfigurable systems. vol. 1, 2006, p. 196–200.
- [43] Wei H-L, Wang ETG. Creating strategic value from supply chain visibility- The dynamic capabilities view, 2007. <https://doi.org/10.1109/HICSS.2007.157>.
- [44] Peinado-Guerrero M, Villalobos JR. Technology-enabled, Rapid-Response Fresh Food Supply Chains: A Paradigm and Case Study. vol. 67, 2022, p. 39–45. <https://doi.org/10.1016/j.trpro.2022.12.033>.
- [45] Lanza G, Stricker N, Peters S. Ad-hoc rescheduling and innovative business models for shock-robust production systems. vol. 7, 2013, p. 121–6. <https://doi.org/10.1016/j.procir.2013.05.021>.
- [46] Shaw NE, Burgess TF, De Mattos C, Stec LZ. Supply chain agility: The influence of industry culture on asset capabilities within capital intensive industries. *International Journal of Production Research* 2005;43:3497–516. <https://doi.org/10.1080/00207540500117805>.
- [47] Nwodu A, Pasha J, Jiang Z, Guo W, Dulebenets M, Wang H, et al. Co-Optimization of Supply Chain Reconfiguration and Assembly Process Planning for Factory-in-a-Box Manufacturing. *Journal of Manufacturing Science and Engineering* 2022;144. <https://doi.org/10.1115/1.4054519>.
- [48] Jiang Z, Wang H, Tian Q, Guo W. Co-design of supply chain network and subassembly planning considering the reconfiguration of supply chain structure for factory-in-a-box manufacturing. vol. 3, 2018. <https://doi.org/10.1115/MSEC2018-6691>.
- [49] Viswanath A, Baca EES, Farid AM. An axiomatic design approach to passenger itinerary enumeration in reconfigurable transportation systems. *IEEE Transactions on Intelligent Transportation Systems* 2014;15:915–24. <https://doi.org/10.1109/TITS.2013.2293340>.
- [50] Gehlhoff F, Fay A. On agent-based decentralized and integrated scheduling for small-scale manufacturing. *At-Automatisierungstechnik* 2020;68:15–31. <https://doi.org/10.1515/auto-2019-0105>.
- [51] Vicentini F, Pedrocchi N, Beschi M, Giussani M, Iannacci N, Magnoni P, et al. PIROS: Cooperative, Safe and Reconfigurable Robotic Companion for CNC Pallets Load/Unload Stations. *Springer Tracts in Advanced Robotics*, vol. 136, 2020, p. 57–96. https://doi.org/10.1007/978-3-030-34507-5_4.
- [52] Kee V, Rojas N, Elara MR, Sosa R. Hinged-Tetro: A self-reconfigurable module for nested reconfiguration, 2014, p. 1539–46. <https://doi.org/10.1109/AIM.2014.6878302>.
- [53] Spinos A, Carroll D, Kientz T, Yim M. Topological reconfiguration planning for a variable topology truss. *Journal of Mechanisms and Robotics* 2021;13. <https://doi.org/10.1115/1.4050530>.
- [54] Guciz AE, Erkmen AM, Erkmen I. Game theoretic colony control of holonic robots inspecting inner surfaces of pipes. vol. 299, 2000, p. 234–40. [https://doi.org/10.1061/40476\(299\)30](https://doi.org/10.1061/40476(299)30).
- [55] Kousi N, Dimosthenopoulos D, Matthaikiak A-S, Michalos G, Makris S. AI based combined scheduling and motion planning in flexible robotic assembly lines. vol. 86, 2020, p. 74–9. <https://doi.org/10.1016/j.procir.2020.01.041>.
- [56] Kalachev A, Zhabelova G, Vyatkin V, Jarvis D, Pang C. Intelligent mechatronic system with decentralized control and multi-agent planning, 2018, p. 3126–33. <https://doi.org/10.1109/IECON.2018.8591390>.
- [57] Buckhorst AF, Montavon B, Wolfschläger D, Buchsbaum M, Shahidi A, Petruck H, et al. Holarchy for line-less mobile assembly systems operation in the context of the internet of production. vol. 99, 2021, p. 448–53. <https://doi.org/10.1016/j.procir.2021.03.064>.
- [58] Xu Q, Qiu R, Russell D. Collaborative supply chain management in semiconductor manufacturing planning, 2003, p. 83–7.