

GLASS
that
STRENGTHENS FLOORS,
FACILITATES CHANGE,
and
TELLS STORIES

TRANSLATION:
A CASE FOR STRUCTURAL GLASS TO RETROFIT THE ROOF OF THE FENIX II, ROTTERDAM



GLASS



CONCRETE



OLD BUILDINGS

STRUCTURAL GLASS

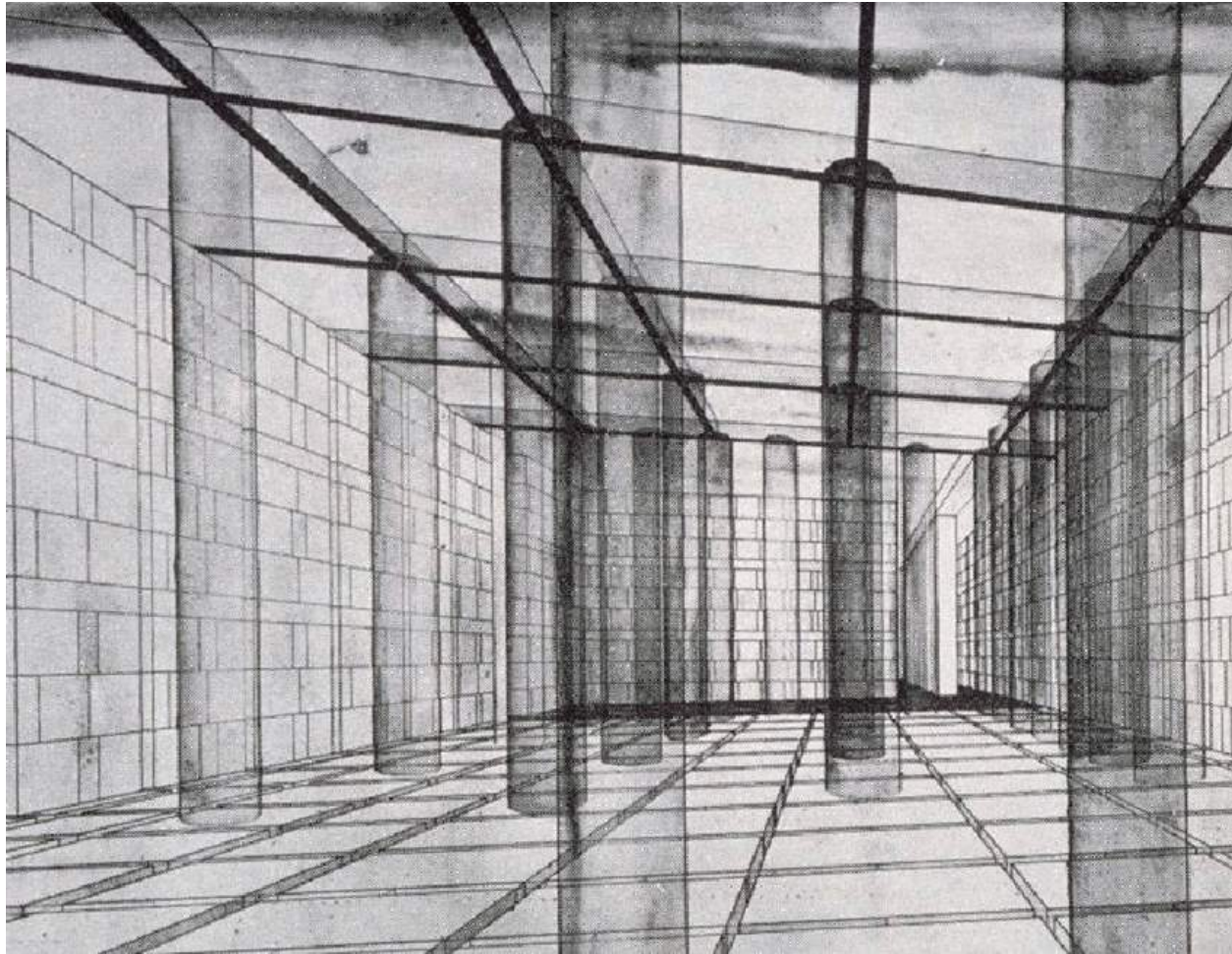

Danteum, 1938
Giuseppe Terragni

STRUCTURAL GLASS



Apple 5th Ave, 2019
Foster + Partners

STRUCTURAL GLASS



Glass II, 2017
MIT Media Lab

STRUCTURAL GLASS



Hermès, 2001
Renzo Piano



Ports, 2015
IUFIE



Crystal Houses, 2016
MVRDV



MFA Houston, 2020
Steven Holl & Associates

TRANSPARENCY

160 Transparency: Literal and Phenomenal

Transparency 1591 1. The quality or condition of being transparent; diaphen-
eity; pellucidity 1615. 2. That which is transparent 1591. b. *spec.* A picture,
print, inscription or device on some translucent substance, made visible by means
of light behind 1807. c. A photograph or picture on glass or other transparent
substance intended to be seen by transmitted light 1874. 3. A burlesque transla-
tion of the German title of address *Durchlaucht* 1844.

If one sees two or more figures overlapping one another, and each of them claims
for itself the common overlapped part, then one is confronted with a contradic-
tion of spatial dimensions. To resolve this contradiction one must assume the
presence of a new optical quality. The figures are endowed with transparency:
that is, they are able to interpenetrate without an optical destruction of each
other. Transparency however implies more than an optical characteristic, it
implies a broader spatial order. Transparency means a simultaneous perception of
different spatial locations. Space not only recedes but fluctuates in a continuous
activity. The position of the transparent figures has equivocal meaning as one sees
each figure now as the closer, now as the further one.¹

Perspecta (Vol. 8), 1963
Colin Rowe and Robert Slutzky



Basilica di Siponto, 2016
Edoardo Tresoldi

GLASS INTERVENTIONS IN HISTORIC BUILDINGS



Massendemonstration vor dem Reichstagsgebäude
Bildarchiv Preussischer Kulturbesitz

GLASS INTERVENTIONS IN HISTORIC BUILDINGS



The Reichstag after WWII
Josef Heinrich Darchinger, 1958

GLASS INTERVENTIONS IN HISTORIC BUILDINGS

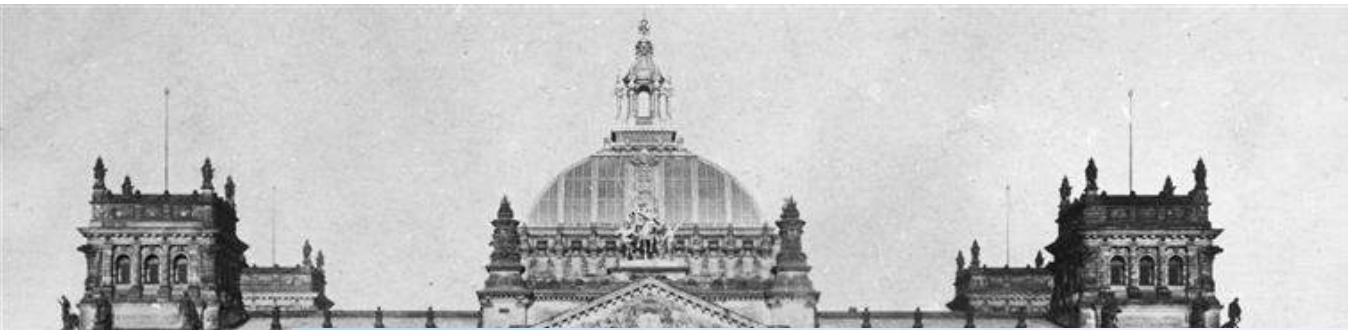

GLASS INTERVENTIONS IN HISTORIC BUILDINGS



Menokin House
Machado Silveira

GLASS INTERVENTIONS IN HISTORIC BUILDINGS



Menokin House
Machado Silveti

[HTTPS://WWW.MENOKIN.ORG/RAISE-THE-GLASS-CAMPAIGN](https://www.menokin.org/raise-the-glass-campaign)

REUSE OF HISTORIC CONCRETE BUILDINGS



Las Palmas
Rotterdam, 1953
Van den Broek & Bakema

REUSE OF HISTORIC CONCRETE BUILDINGS



Bentham Crouwel Architekten, 2008



libelings van Tilburg, 2012



TO WHAT EXTENT CAN STRUCTURAL
GLASS COMPONENTS BE USED TO
STRENGTHEN CONCRETE HERITAGE
BUILDINGS, IN LIEU OF THE PREVAILING
CONVENTIONAL METHODS?

CASE STUDY



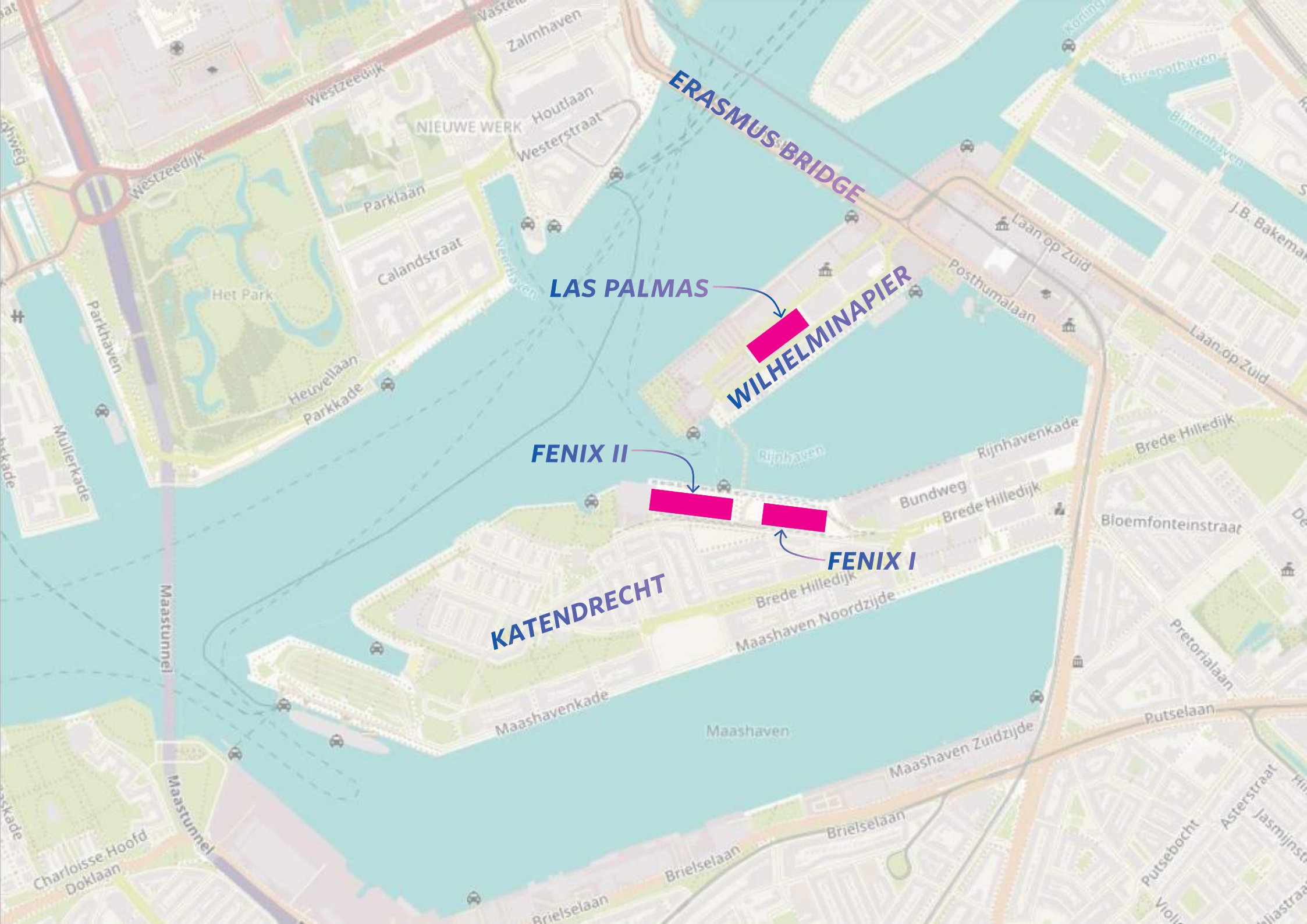

ERASMUS BRIDGE

LAS PALMAS

WILHELMINAPIER

FENIX II

FENIX I

KATENDRECHT

CASE STUDY: FENIX II



CASE STUDY: FENIX II

2019 ADDITION

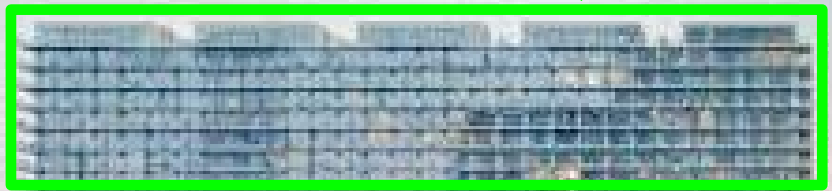

DEMOLISHED 1947

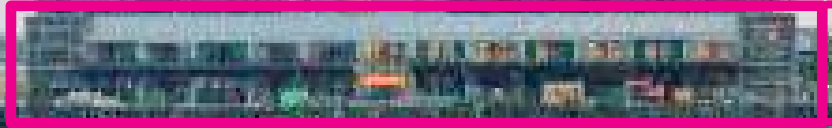

FENIX I



FENIX II

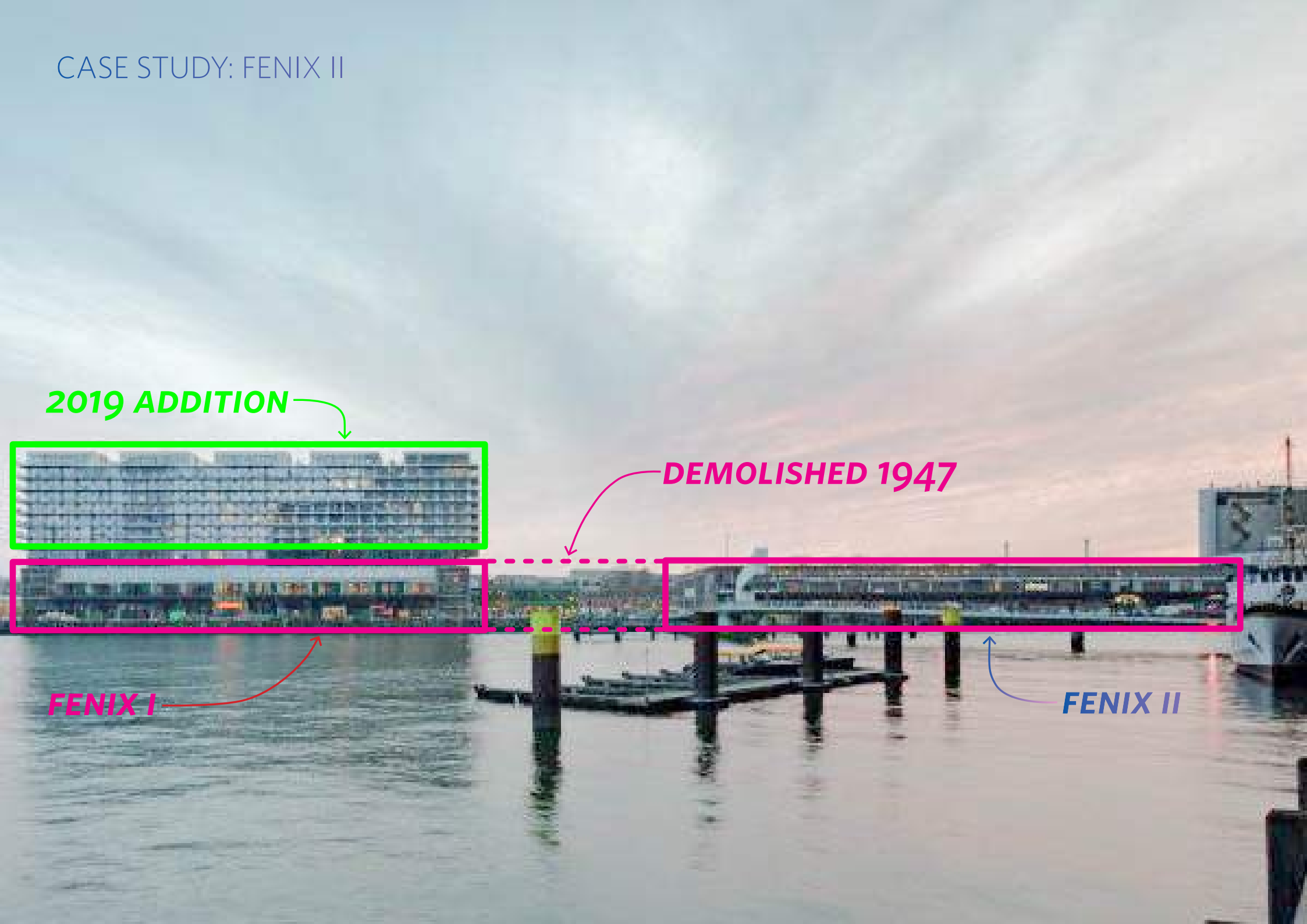



Ronde van Katendrecht
1958



Ronde van Katendrecht
2018

CASE STUDY: FENIX II



CASE STUDY: FENIX II



Current state of demolition
Olympia Apostolopoulou, yesterday

CASE STUDY: FENIX II



Rijnhaven facade
Bouwkundig Weekblad, 1931

CASE STUDY: FENIX II



Roof construction
Archief Holland-Amerika Lijn, Rotterdam

CASE STUDY: FENIX II

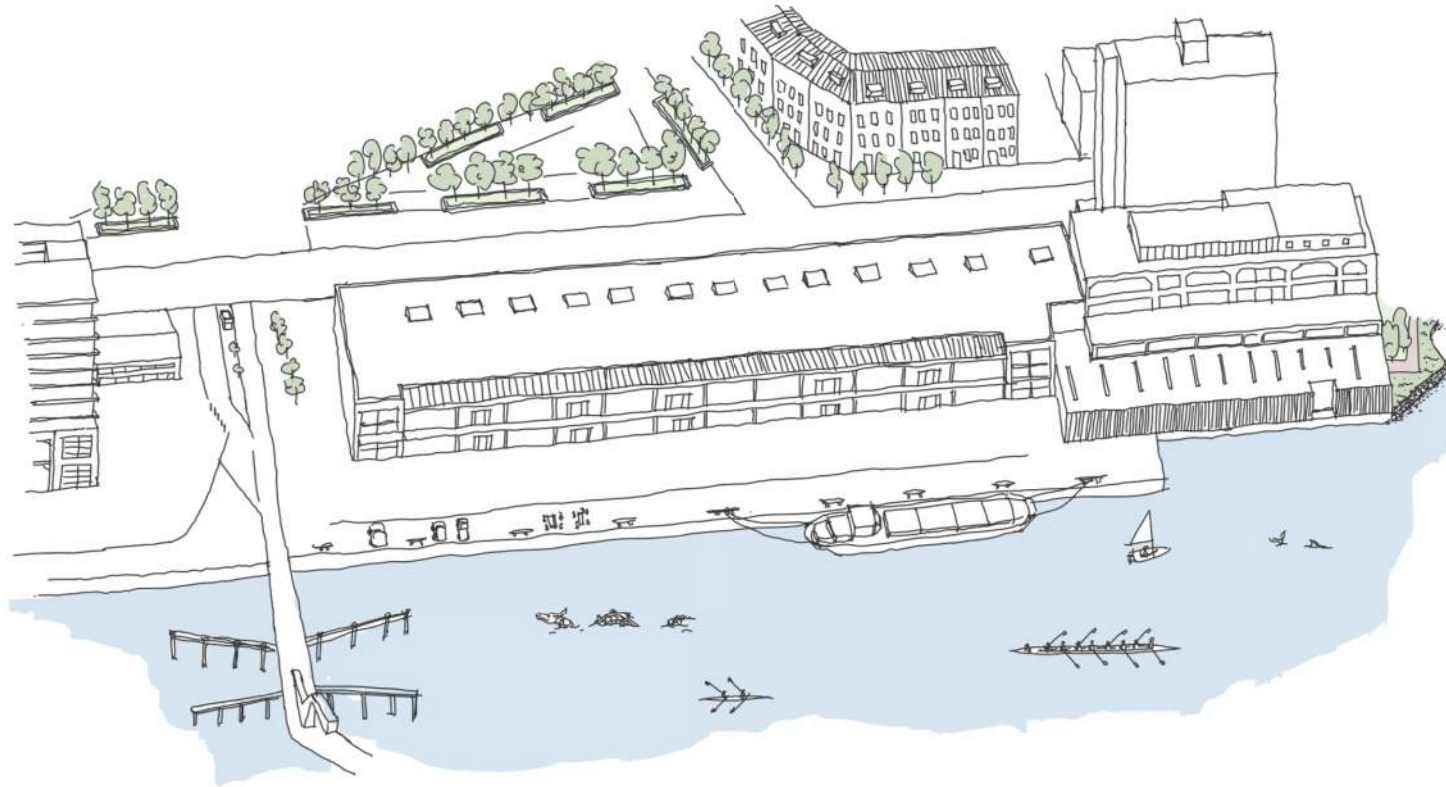

ORIGINAL ROOF DESIGN LOAD: 4.98 kN/m²

maintenance
service
rain/snow

CASE STUDY: PROPOSED NEW USES

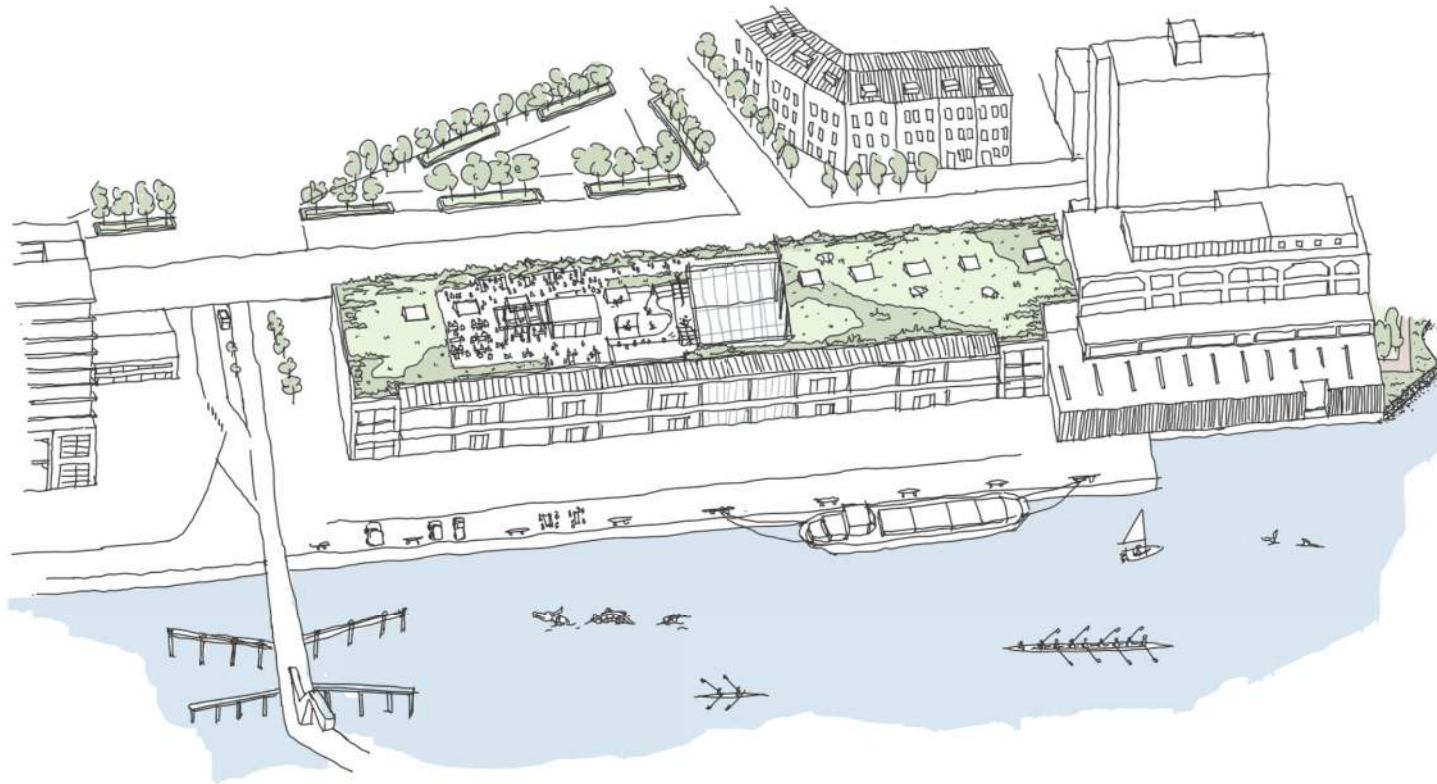

**NEW DESIGN LOADS: 10.8 kN/m^2
 11.0 kN/m^2
 12.5 kN/m^2**

CASE STUDY: PROPOSED NEW USES



ROOF GARDEN

CASE STUDY: PROPOSED NEW USES

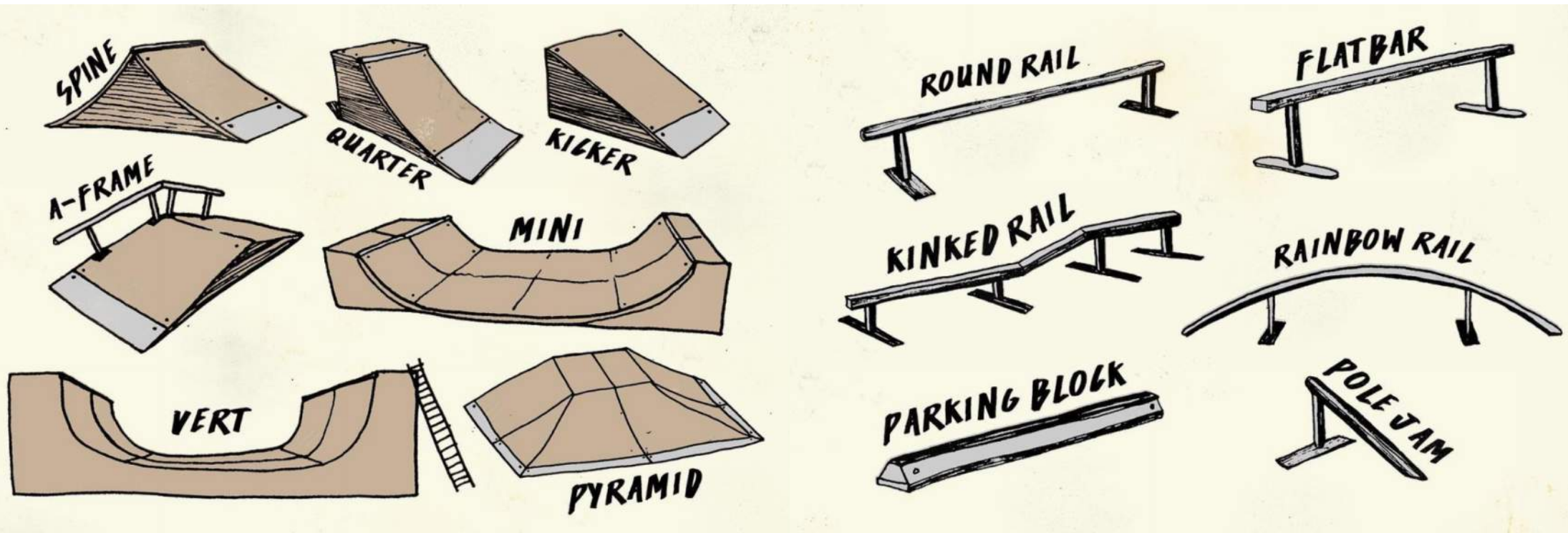

SKATEBOARDING

CASE STUDY: PROPOSED NEW USES



BAR/CAFE/EVENTS

1. ANALYZE ORIGINAL STRUCTURE



Riet Garcia-Bruns
Stichting Historisch Katendrecht

EXISTING CONCRETE / ABT FENIX I

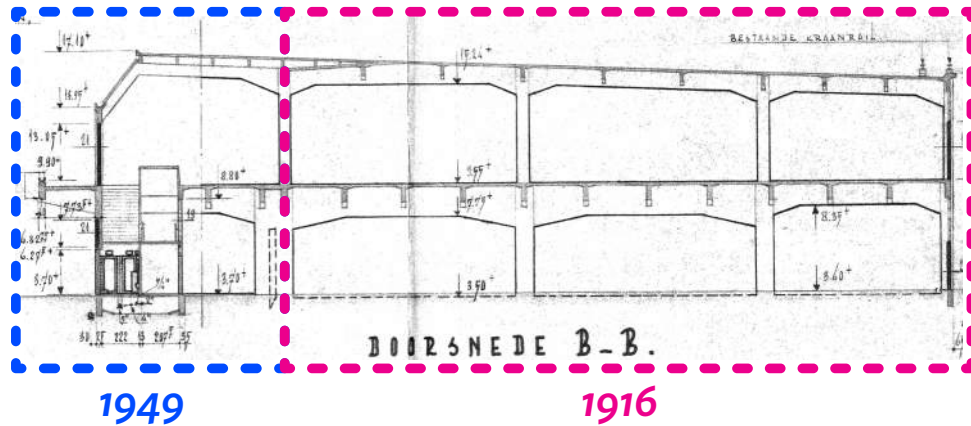

constructieonderdeel	bouwdeel	genormeerde betonsterkteklasse
		conform bijlage D NEN-EN 1990
kolommen	nieuw	C35/40
	oud	C12/15
balken	oud incl. gevelzijde Veerlaan	C12/15
	nieuw	C20/25
	oud	C15/20
vloeren	oud incl. gevelzijde Veerlaan	C12/15
	nieuw	C25/30
	oud	C20/25

Capaciteit bestaande constructie

- "ontdekking" originele berekening ($VB = 5 \text{ kN/m}^2$ ipv 10 kN/m^2)
- Werkelijke betonkwaliteit bepaald (kernen geboord) -> lage sterkte
- Bekende wapening (1916) onbekende wapening (1949)
- Andere mechanicschema's (doorgezaagde balken, belasting erbij)

EXISTING CONCRETE / TYPICAL BAY

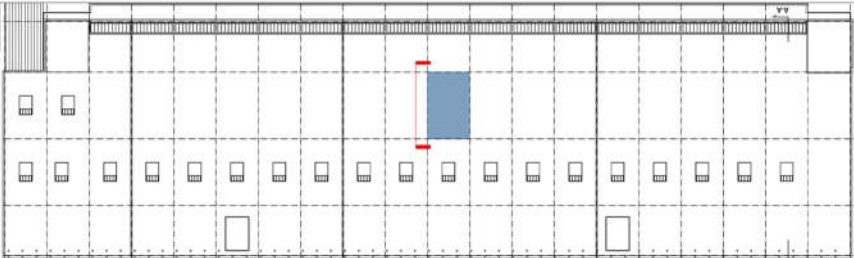

roof plan

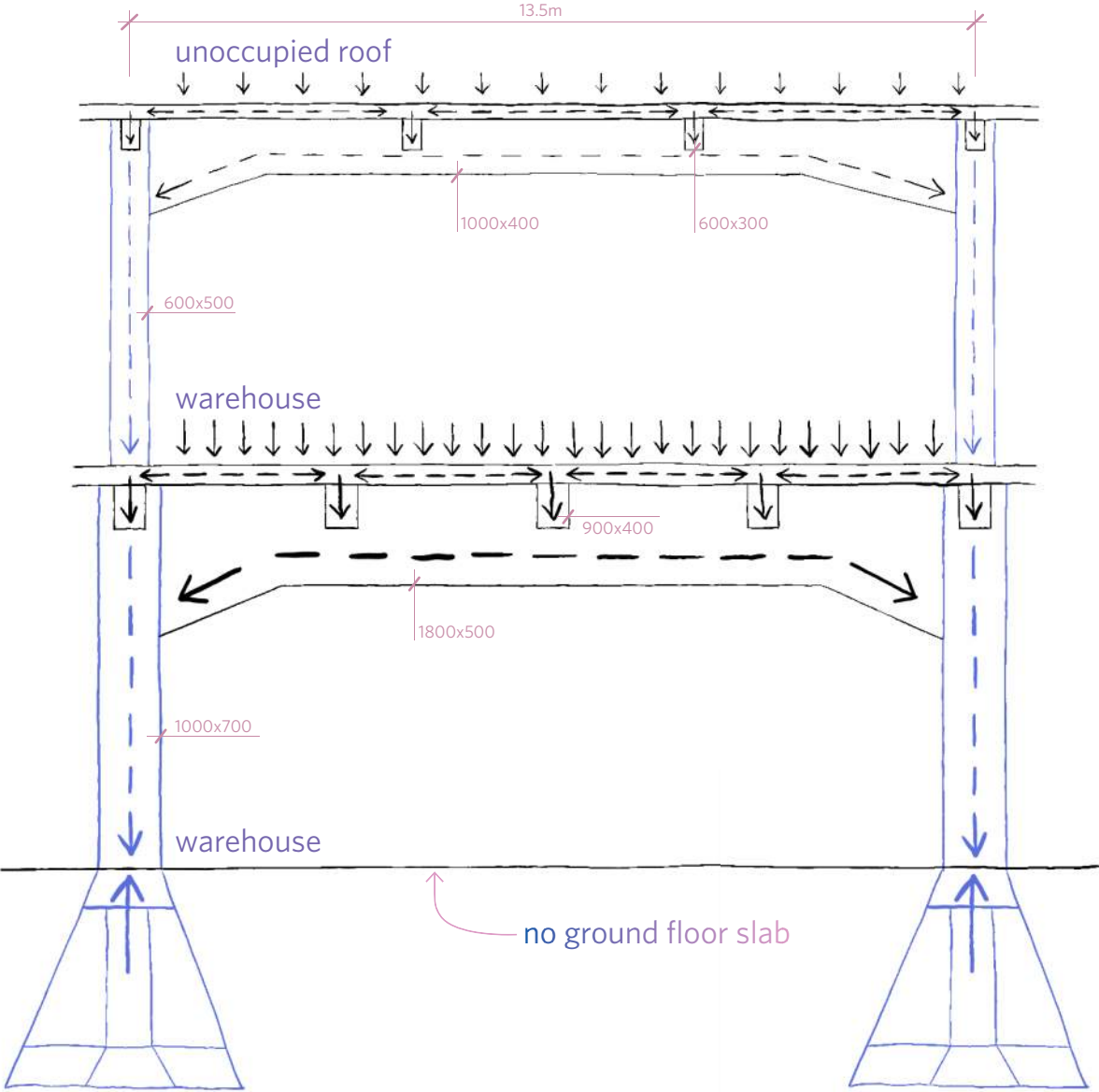

$$M = \frac{1}{10} \times 33900 \times 8.6 = 29200 \text{ Kg m}$$

$$Z = 0.90 - 0.13 = 0.77 \text{ m}$$

10-22φ = 38.00

$$T_b = \frac{2m}{Z \times b \times d} = \frac{2 \times 29200}{0.77 \times 160 \times 13} = \underline{\underline{36.5 \text{ Kg per cm}^2}}$$

$$T_y = \frac{m}{Z \times f_y} = \frac{29200}{0.77 \times 38} = \underline{\underline{1000 \text{ Kg per cm}^2}}$$

$$T_s = \frac{1.5 \times 16950}{40 \times 130} = \underline{\underline{4.9 \text{ Kg per cm}^2}}$$

Dak plaatoverspanning 4.10 m $T_b = 60$ $T_y = 1000$

0.289 V m

0.411 V m

Mob. belasting 140 Kg
 eigen gewicht 240 "
380 Kg

Pos. Moment

$$M = \frac{1}{10} \times 380 \times 4.1^2 = 640 \text{ Kg m}$$

$$h-a = 0.289 \text{ V m} = 7.33 \text{ cm}$$

$$f_y = 0.411 \text{ V m} \times \frac{7.33}{8.0} = 8.97 \text{ Kg/cm}^2$$

8 staven 12φ = 9.04
 56 overniet.

$$M = \frac{1}{10} \times 33900 \times 8.6 = 29200 \text{ Kg m}$$

$$Z = 0.90 - 0.13 = 0.77 \text{ m}$$

10-22φ = 38.00

$$T_b = \frac{2m}{Z \times b \times d} = \frac{2 \times 29200}{0.77 \times 160 \times 13} = \underline{\underline{36.5 \text{ Kg per cm}^2}}$$

$$T_y = \frac{m}{Z \times f_y} = \frac{29200}{0.77 \times 38} = \underline{\underline{1000 \text{ Kg per cm}^2}}$$

$$T_s = \frac{1.5 \times 16950}{40 \times 130} = \underline{\underline{4.9 \text{ Kg per cm}^2}}$$

Dak plaatoverspanning 4.10 m $T_b = 60$ $T_y = 1000$

0.289 \sqrt{m}
0.411 \sqrt{m}

Mob. belasting	140 Kg.
eigen gewicht	240 "
	<hr/>
	380 Kg.

DESIGN LOAD

$$M = \frac{1}{10} \times 380 \times 4.1^2 = 640 \text{ Kg m.}$$

$$h-a = 0.289 \sqrt{m} = 7.33 \text{ cm}$$

$$f_y = 0.411 \sqrt{m} \times \frac{7.33}{8.0} = 8.97 \text{ Kg/cm}^2$$

AREA OF REINFORCEMENT

3 staven 12φ = 9.04
5 bovennet.

EXISTING CONCRETE / DESIGN LOADS AT ROOF

Concrete self-weight

100m slab = 2.4 kN/m^2

Service live load

1.4 kN/m^2

equivalent to:

weight of one fat cowboy per m^2

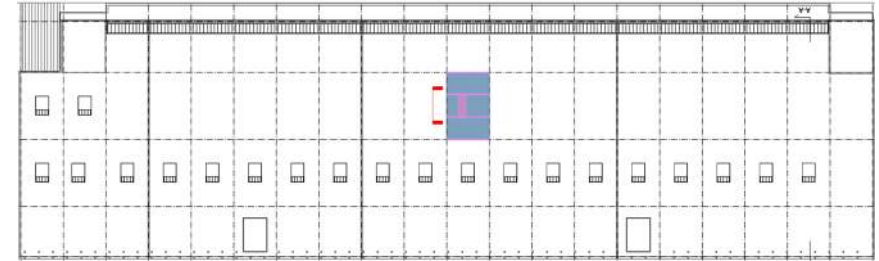

roof plan

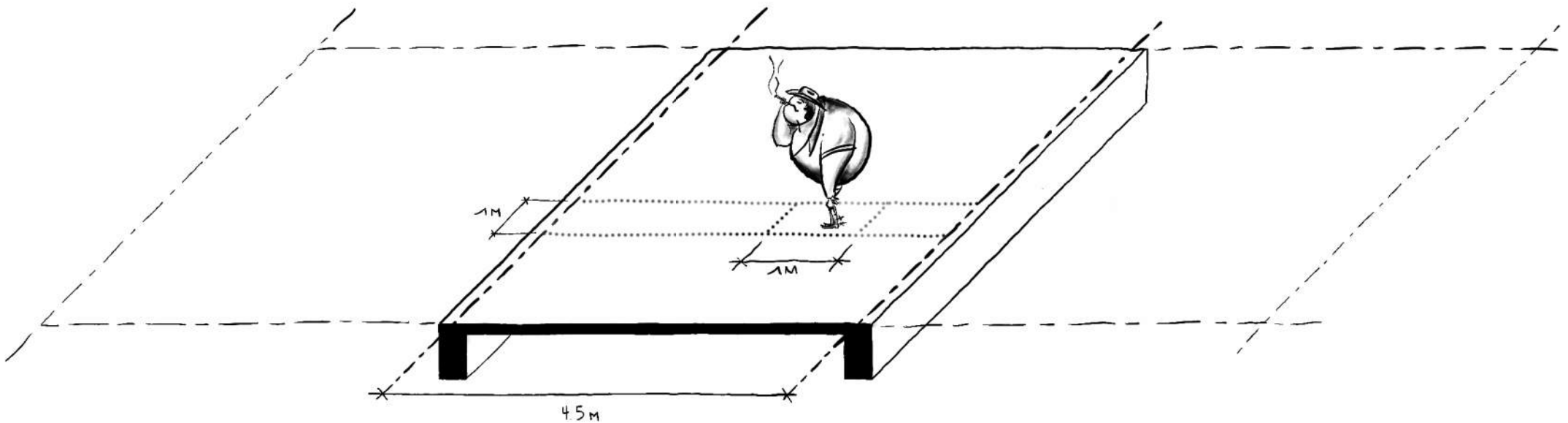

EXISTING CONCRETE / SLAB

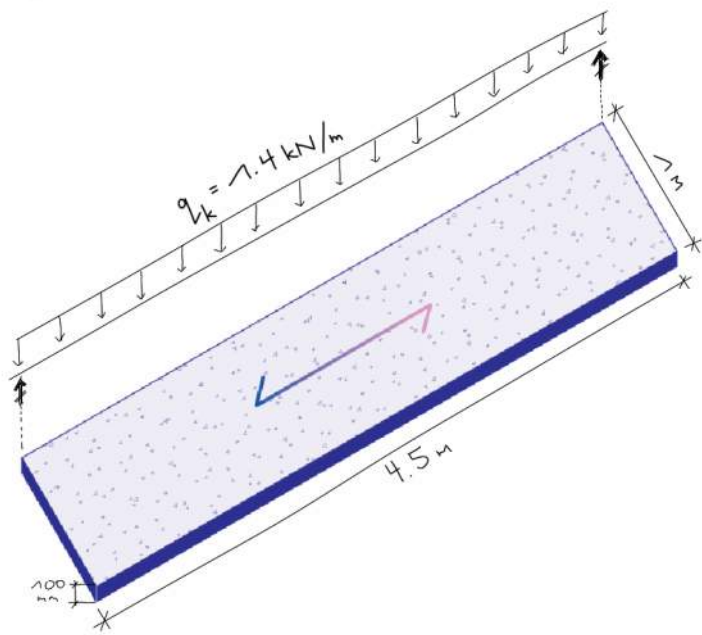

TENSION
REINFORCEMENT

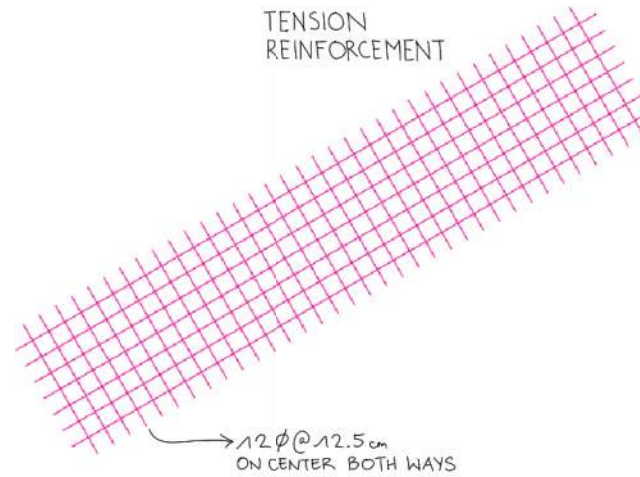

COMPRESSION
REINFORCEMENT

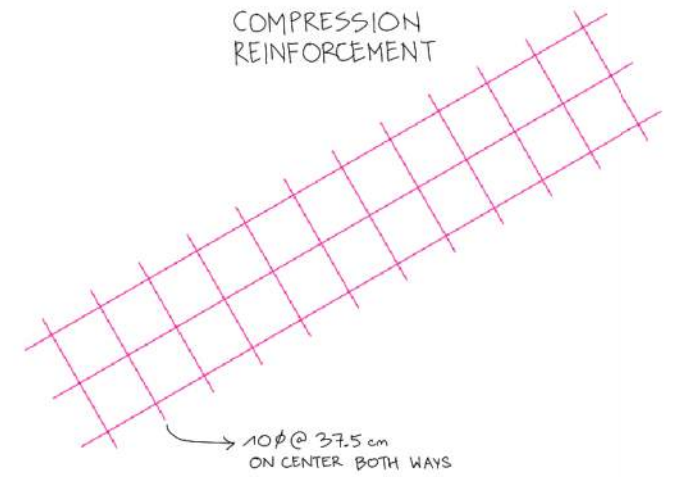

Dak

Kinderbinten

30 x 60.

Bint 35.

Overspanning 0.60 M.

DESIGN LOAD

Mob. belasting incl. eigen gewicht 18800 Kg.

Pos. Moment.

$$M_b = \frac{1}{10} \times 18800 \times 0.6 = 16200 \text{ Kg m.}$$

$$z = 0.60 - 0.10 = 0.50$$

AREA OF REINFORCEMENT

$$T_b = \frac{2m}{bdz} = \frac{2 \times 16200}{280 \times 10 \times 0.5} = \underline{\underline{23.2 \text{ Kg per cm}^2}}$$

$$\begin{array}{r} 3-25\phi = 14.73 \\ 2-22\phi = 19 \\ \hline 33.73 \end{array}$$

$$T_y = \frac{m}{f_y z} = \frac{16200}{33.73 \times 0.5} = \underline{\underline{9.65 \text{ Kg per cm}^2}}$$

Neg. Moment Console hoogte 0.90 M.

$$M = \frac{1}{8} \times 18800 \times 0.6 = 20200 \text{ Kg m}$$

$$x = \frac{m f_y}{6} \left[-1 + \sqrt{1 + \frac{26(k-a)}{m f_y}} \right] = \frac{15 \times 29.74}{30} \left[-1 + \sqrt{1 + \frac{60 \times 85}{15 \times 29.74}} \right] = 3.77$$

$$\begin{array}{r} 3-19\phi = 0.52 \\ 2-25\phi = 9.82 \\ 3-22\phi = 11.4 \\ \hline 29.74 \end{array}$$

EXISTING CONCRETE / BEAM

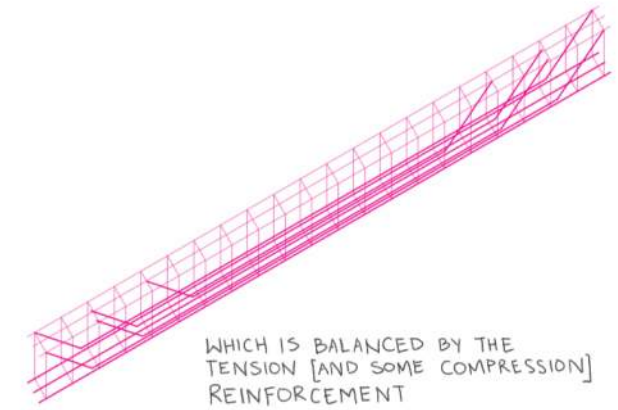
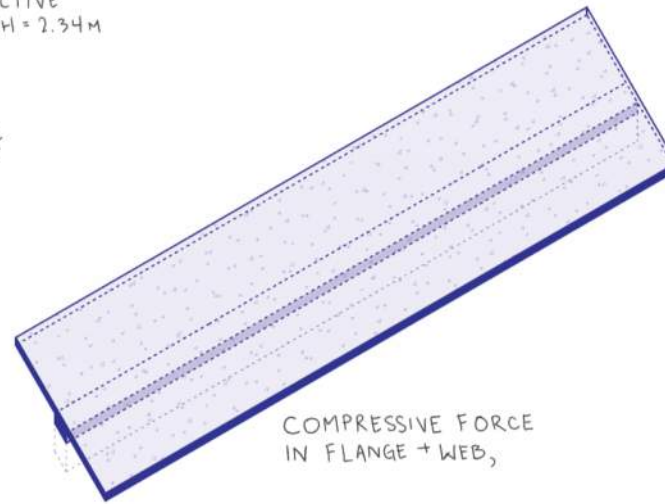
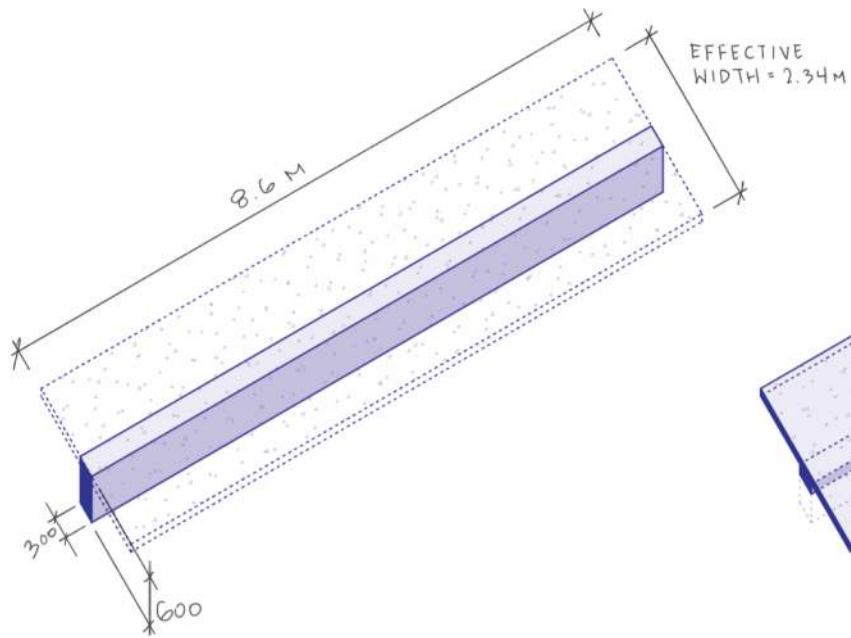
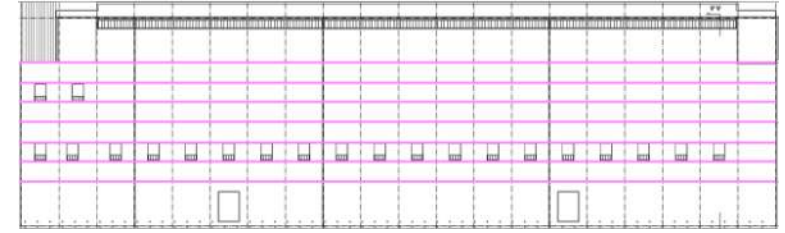

EXISTING CONCRETE / GIRDER

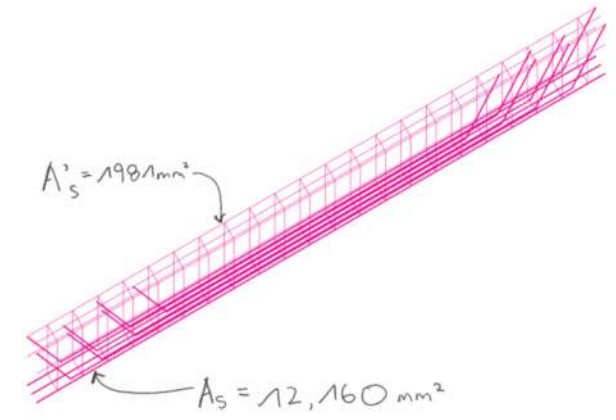
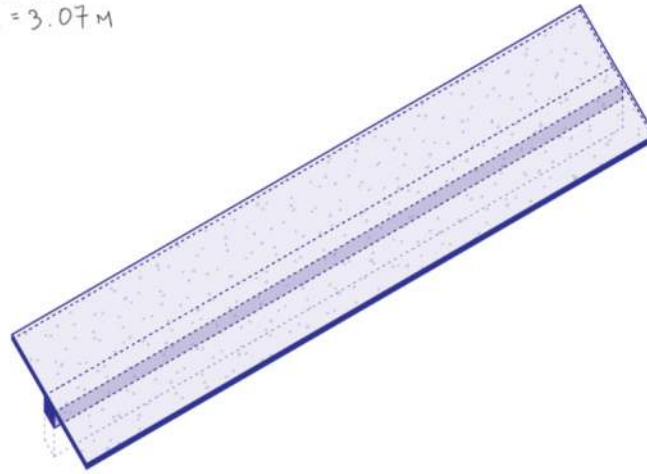
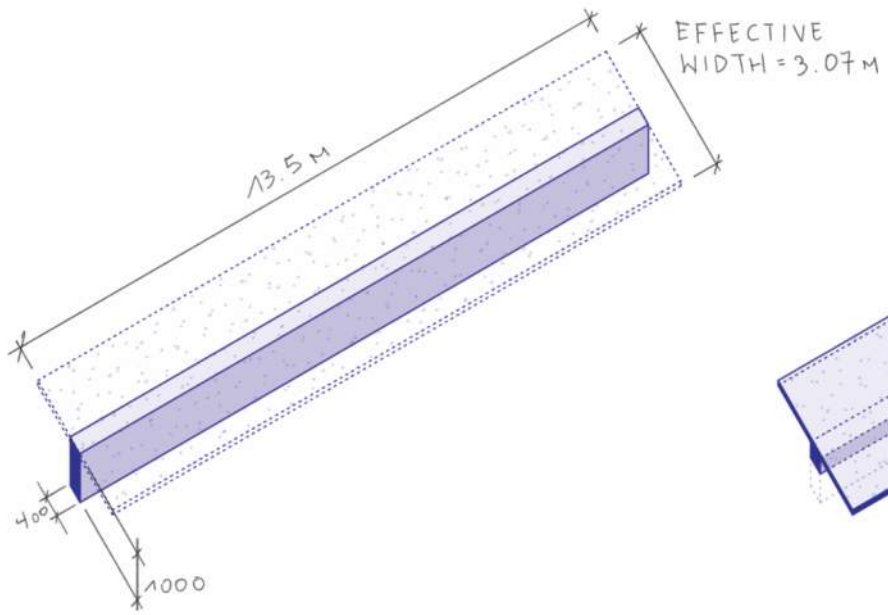
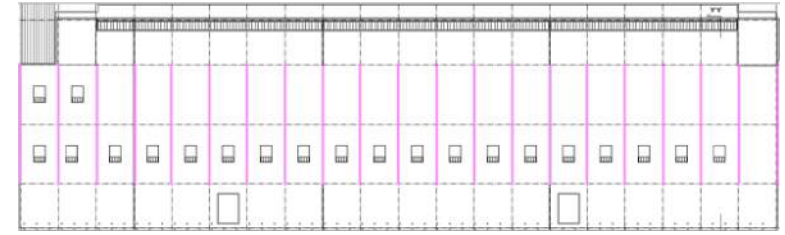

EXISTING CONCRETE / UTILIZATION

	Moment	Reinforcement	Deflection
SLAB	0.8	1.07	0.53
BEAM	0.85	0.73	0.3
GIRDER	0.41	0.48	0.26

EXISTING CONCRETE / UTILIZATION

	Moment	Reinforcement	Deflection	
SLAB	0.8	1.07	0.53	WITH 4.98 kN/m²
BEAM	0.85	0.73	0.3	
GIRDER	0.41	0.48	0.26	

EXISTING CONCRETE / UTILIZATION

	Moment	Reinforcement	Deflection	
SLAB	0.8	1.07	0.53	WITH 4.98 kN/m²
BEAM	0.85	0.73	0.3	SOME EXCESS CAPACITY
GIRDER	0.41	0.48	0.26	

EXISTING CONCRETE / UTILIZATION

	Moment	Reinforcement	Deflection	
SLAB	0.8	1.07	0.53	WITH 4.98 kN/m²
BEAM	0.85	0.73	0.3	SOME EXCESS CAPACITY
GIRDER	0.41	0.48	0.26	BUT MORE HERE

PREVAILING METHODS OF STRENGTHENING

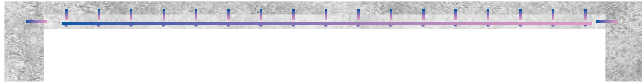

extend cross section

- invasive
- irreversible
- + same material



steel

- alters perception of existing space
- + can carry heavier loads
- + reversible



fiber-reinforced polymers (GFRP/CFRP)

- less effective than other options
- irreversible
- + no change to cross-section



USE GLASS

reversibility

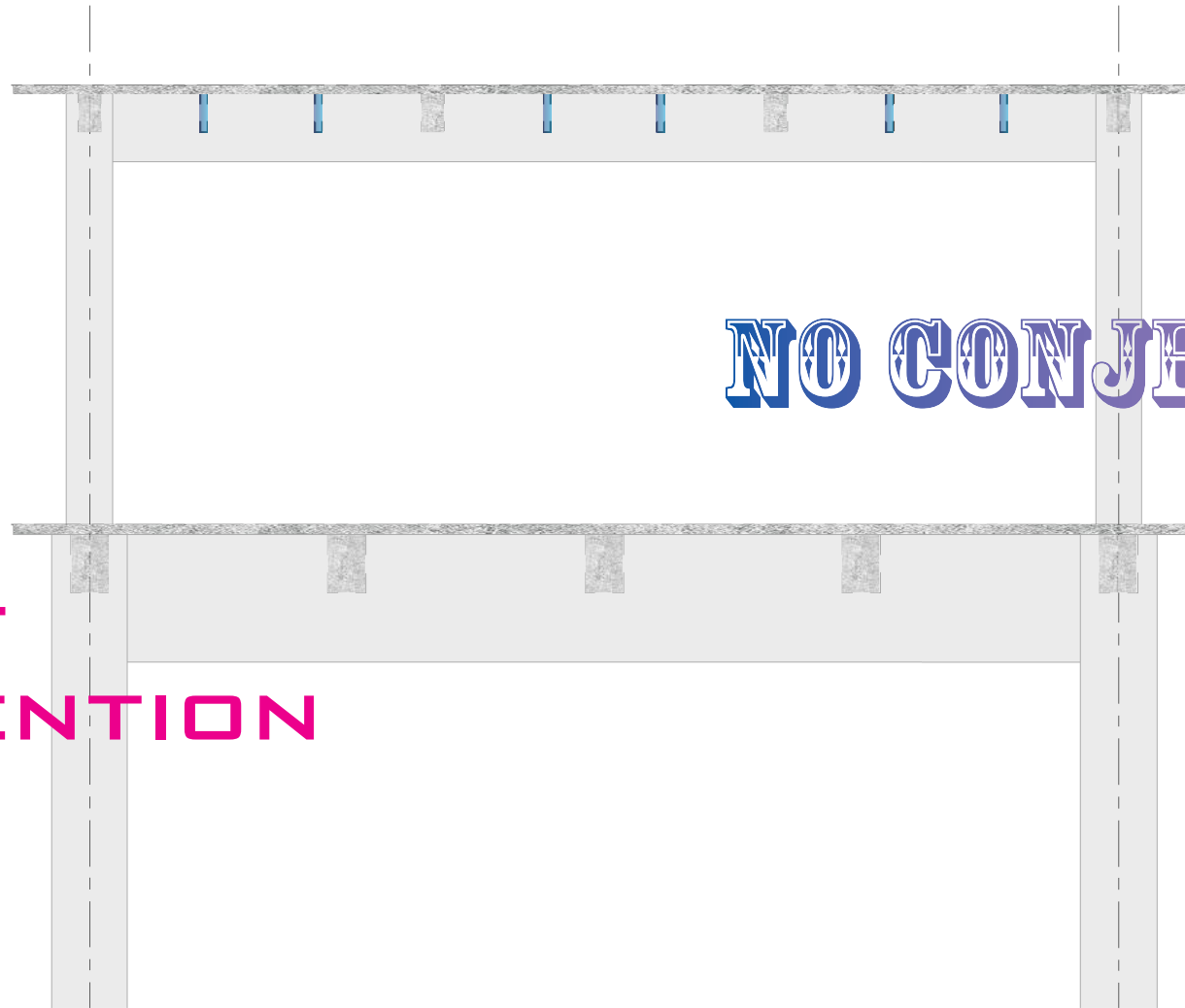

NO CONJECTURE

**MINIMAL
INTERVENTION**

durability

TYPES OF GLASS

annealed

- low strength
- + breaks into large shards



heat-strengthened

- + keeps strength, maintains residual capacity at fracture



fully tempered

- crumbles, loses stiffness
- + high bending strength



laminated

- difficult to recycle
- + holds together when broken

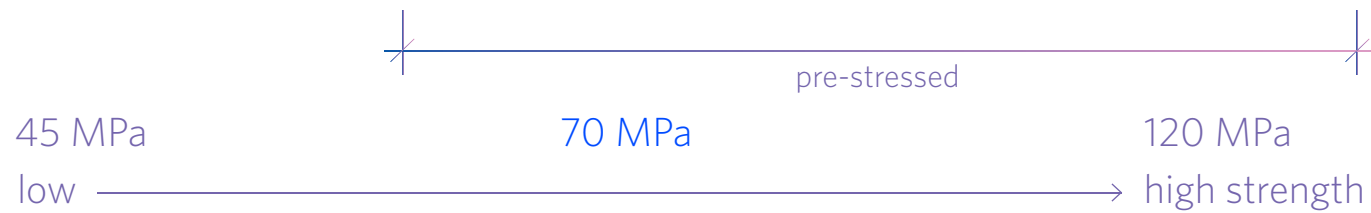
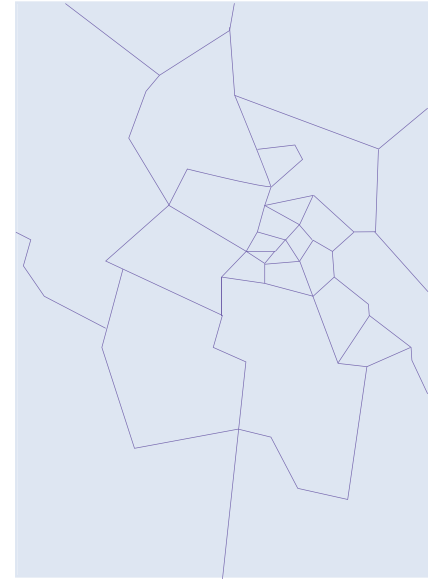

DESIGN LOAD

Concrete self-weight

100m slab = 2.4 kN/m



+

New use*

*in cowboy notation

1. Green roof

1 cowboy and 2 horses



Permanent:	roofing	0.5 kN/m ²	estimated
	0.3m dirt	4.5 kN/m ²	packed earth
Variable:	service	1.0 kN/m ²	EN 1991, H
	some animals	0.3 kN/m ²	unit weight 2 pigs

Total factored: 10.8 kN/m

2. Skatepark

2 cowboys and 2 horses



Permanent:	roofing	0.5 kN/m ²	estimated
Variable:	areas physical activity	5.0 kN/m ²	EN 1991, C4

Total factored: 11.0 kN/m

3. Bar

3 cowboys and 2 horses



Permanent:	roofing	0.5 kN/m ²	estimated
Variable:	areas physical activity	5.0 kN/m ²	EN 1991, C4
	partitions	1.0 kN/m ²	estimated

Total factored: 12.5 kN/m

DESIGN STUDY 1

Add new beams between secondary concrete beams:

- 1. shortest span = save material
- 2. change direction of slab span

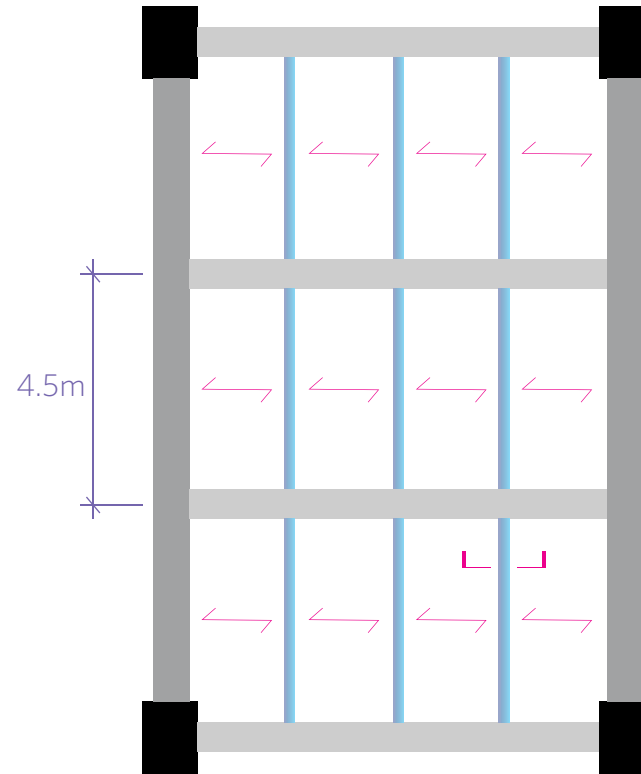

Size glass beams to accept all new loads:

existing concrete slab carries own self-weight



+

new beams carry new loads

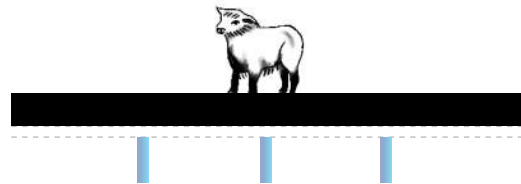

=

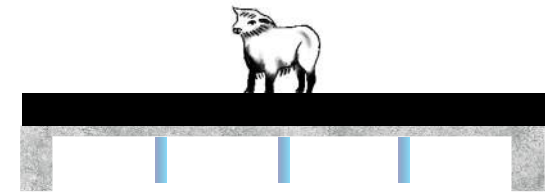

DESIGN STUDY 1

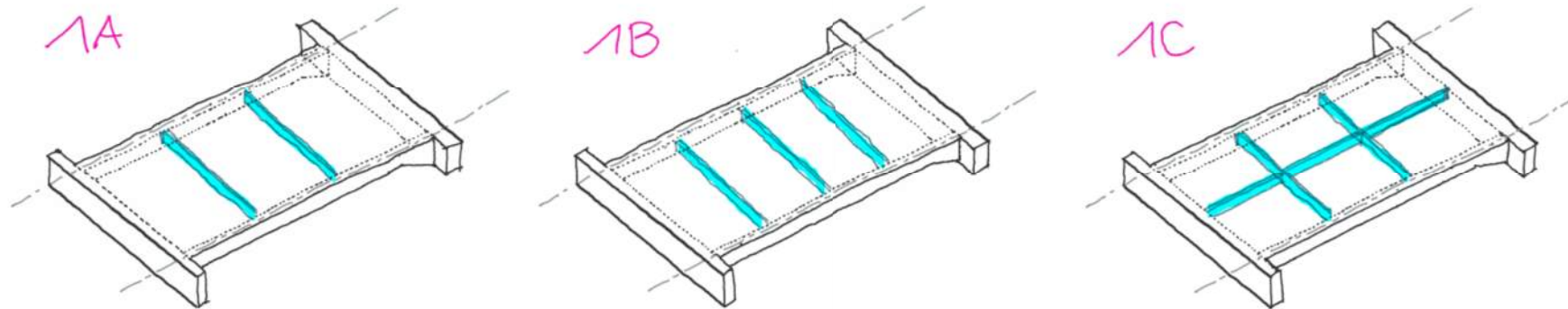
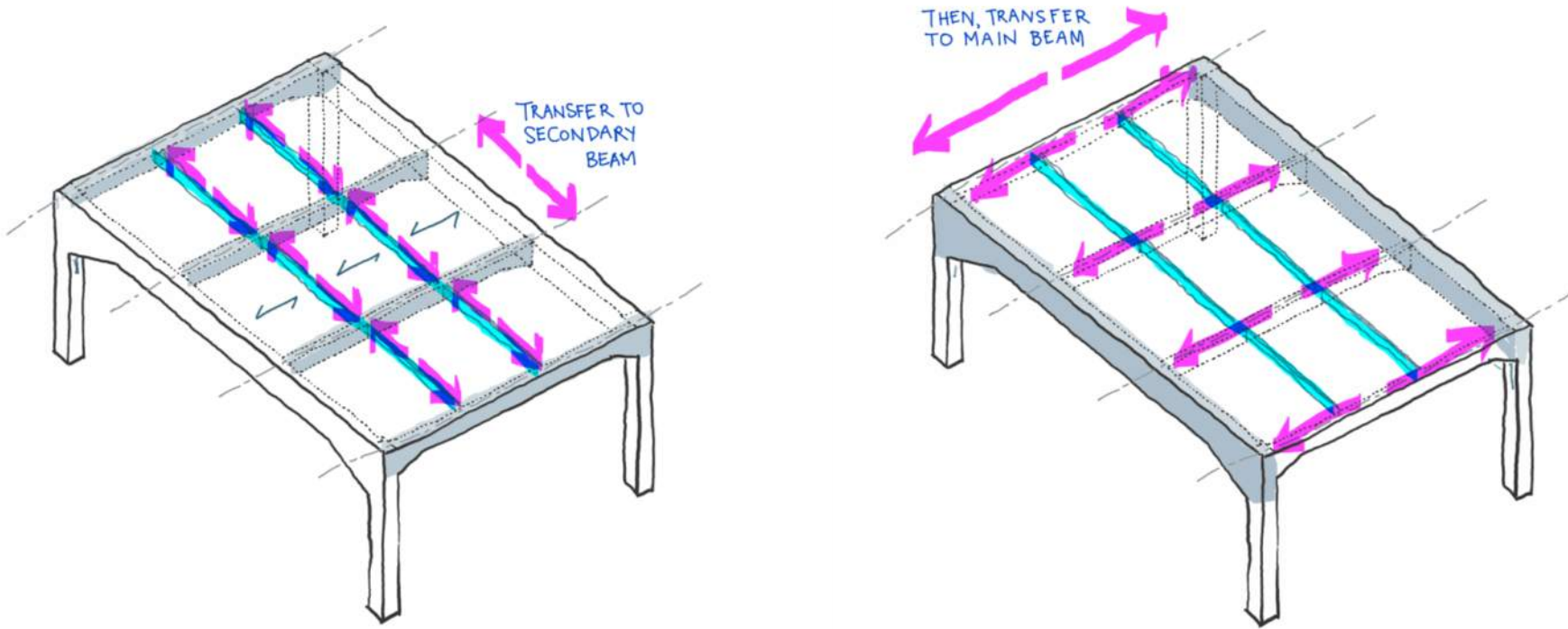

NEW GLASS BEAM

EXISTING CONCRETE BEAM

DESIGN STUDY 1 / CHECK SLAB, BEAM

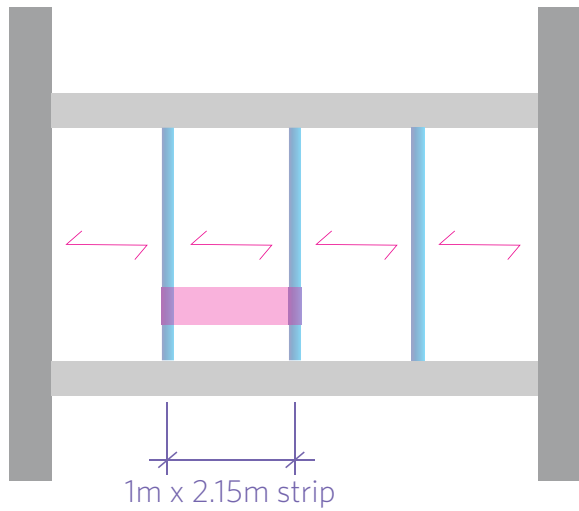

Check concrete slab is still ok in bending

include self-weight of slab + new loads

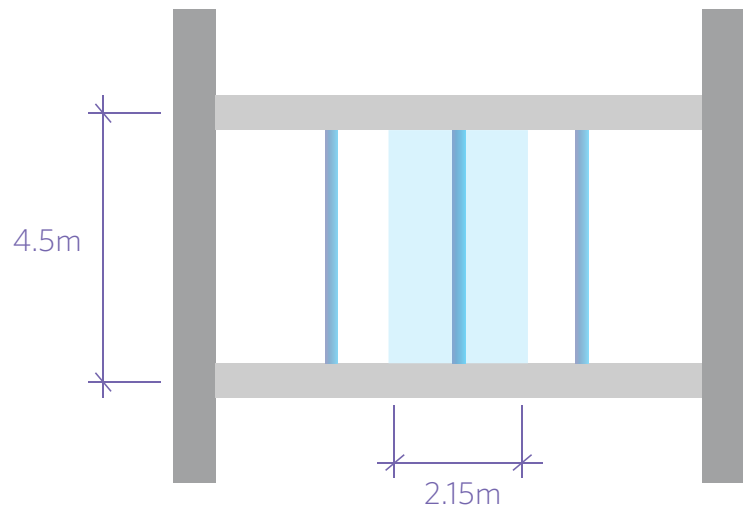

Check utilization and deflection of glass beam

include only new loads

**at the bar:
with a tributary
width of 2.15m,
use 75x310mm**

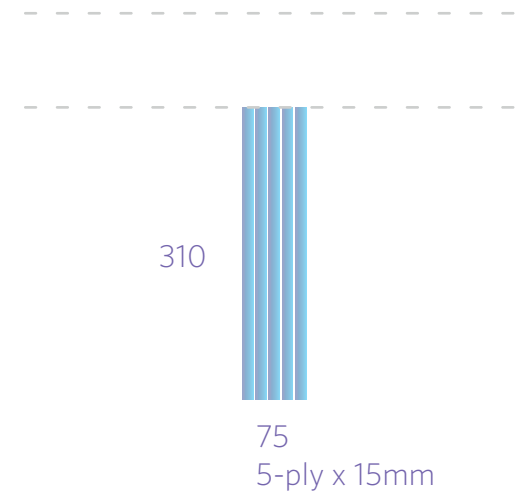

DESIGN STUDY 2 / REDUCE SECTION BY COMPOSITE ACTION

Instead of all new loads to glass,

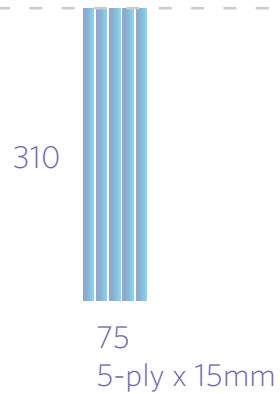

75x310mm

governing in bending

let an effective width of the
concrete slab act as a T-section flange.

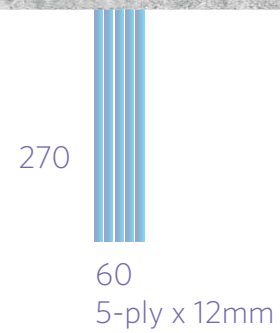

60x270mm

deflection governing

= 30%

reduction in material

Check the beam if two plies didn't function in an accidental limit state, such as fire

Bar: UC: 0,50

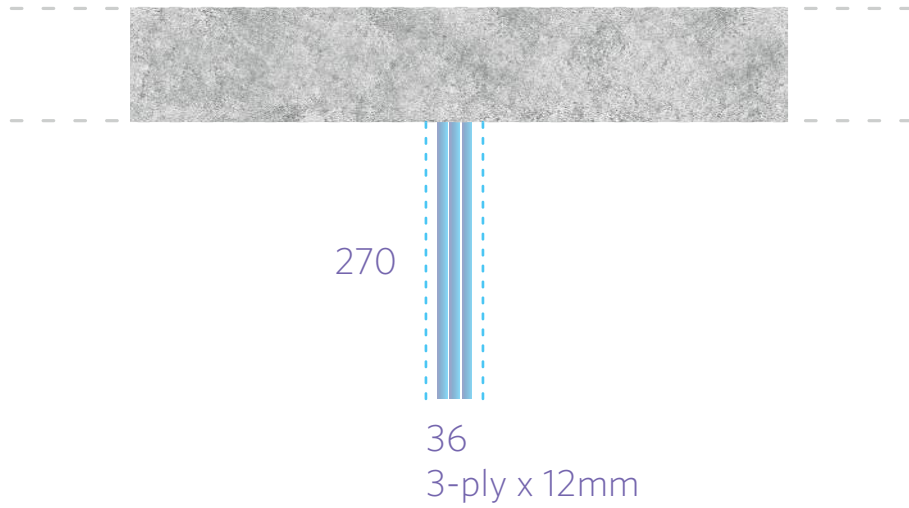

Garden: UC: 0,92

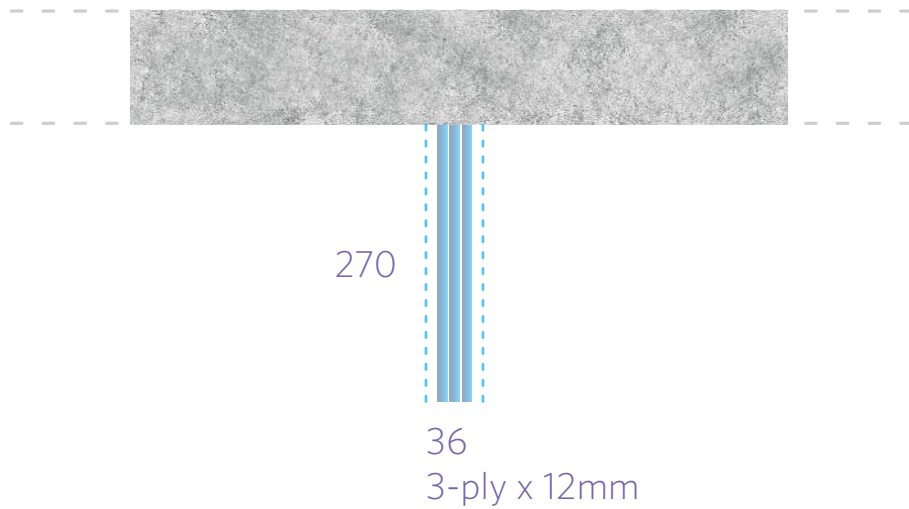

DESIGN STUDY 1 / EXISTING BEAM STRENGTHENING

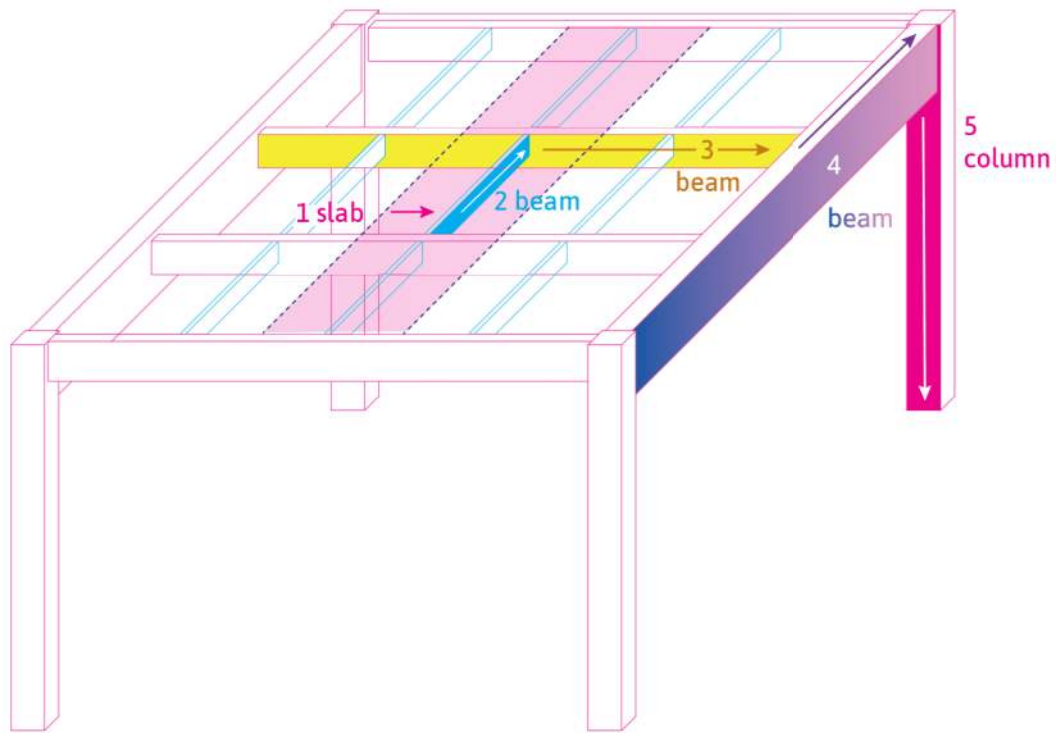

DESIGN STUDY 1 / EXISTING BEAM STRENGTHENING

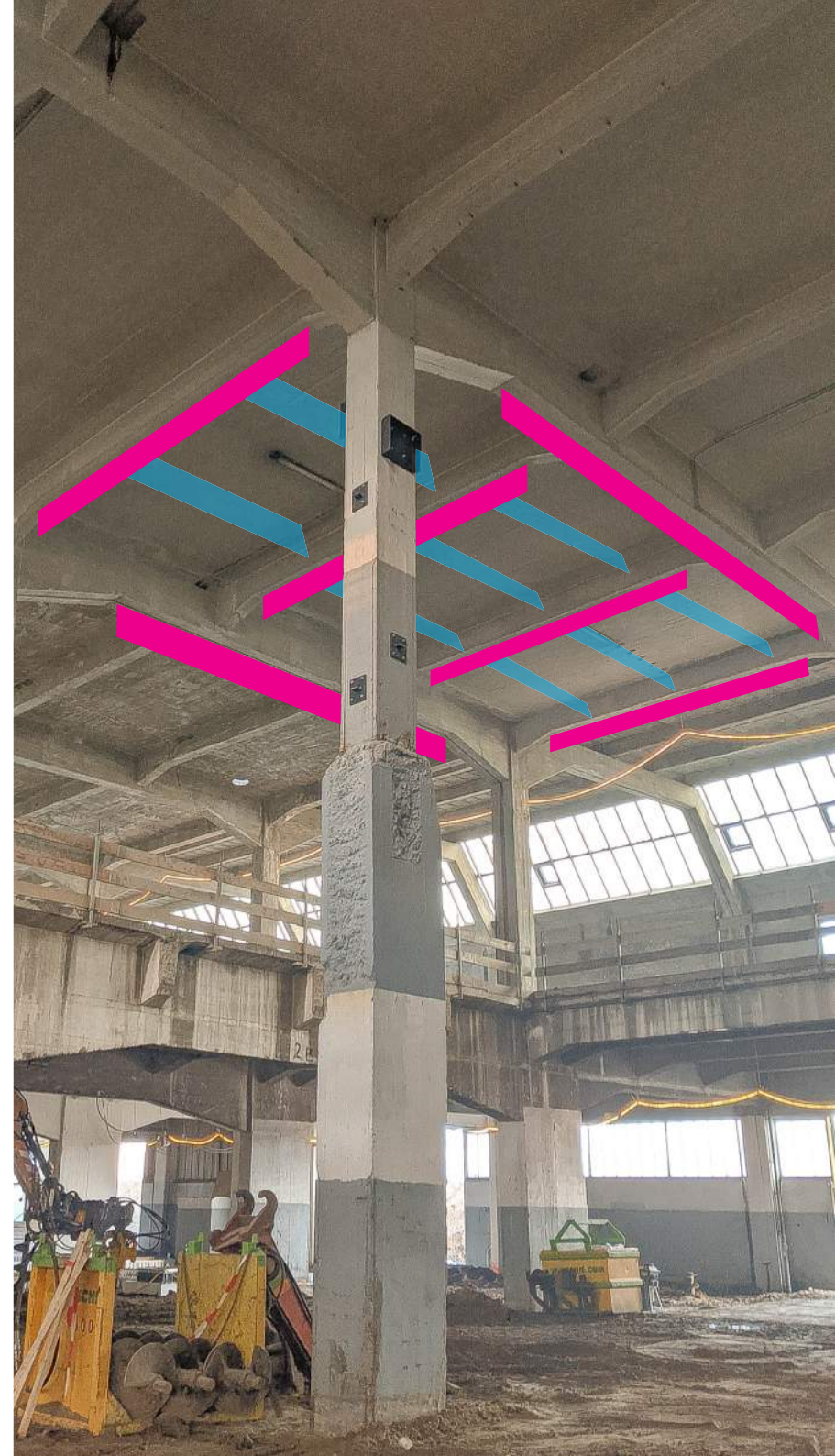
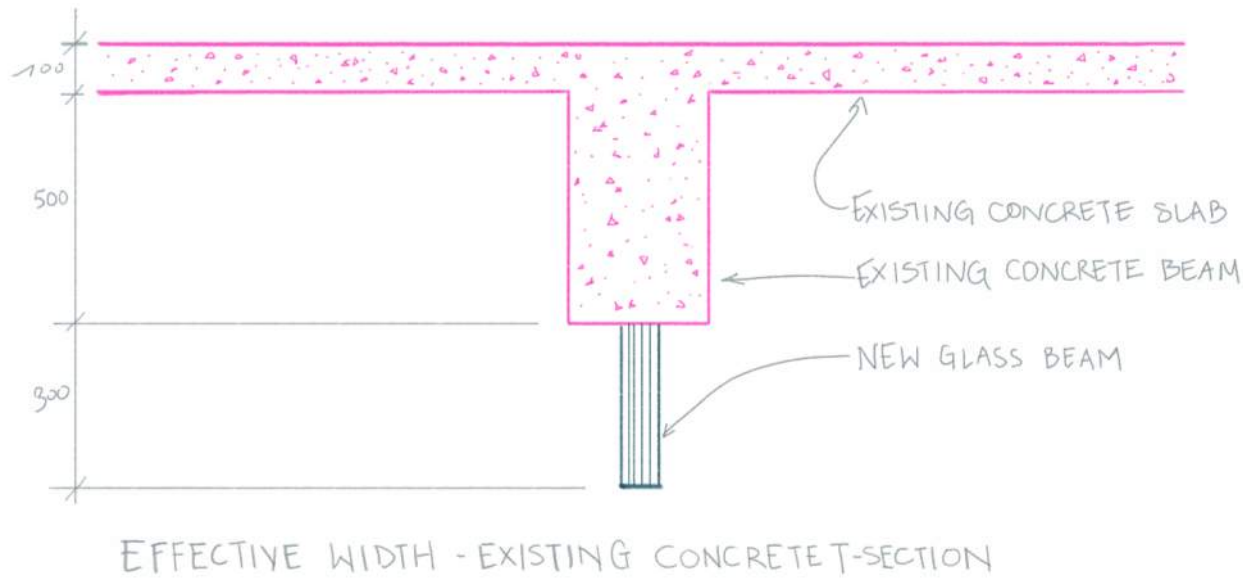
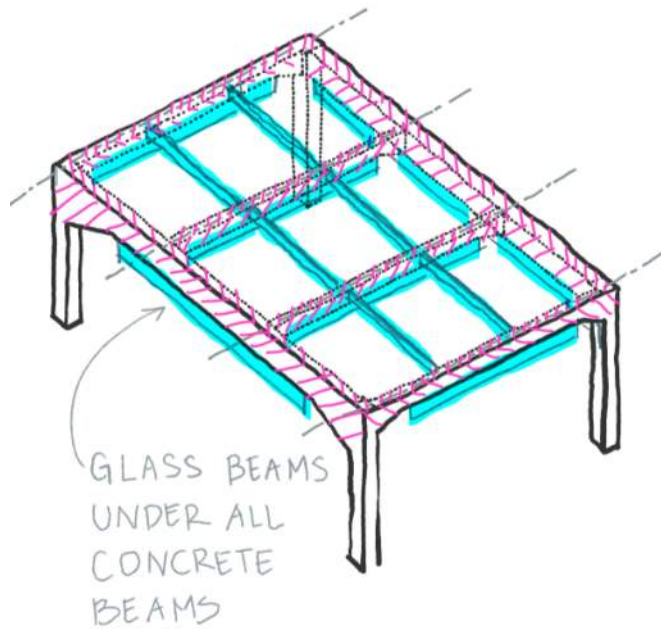



DESIGN STUDY 2 / GRAVITY LOAD PATH

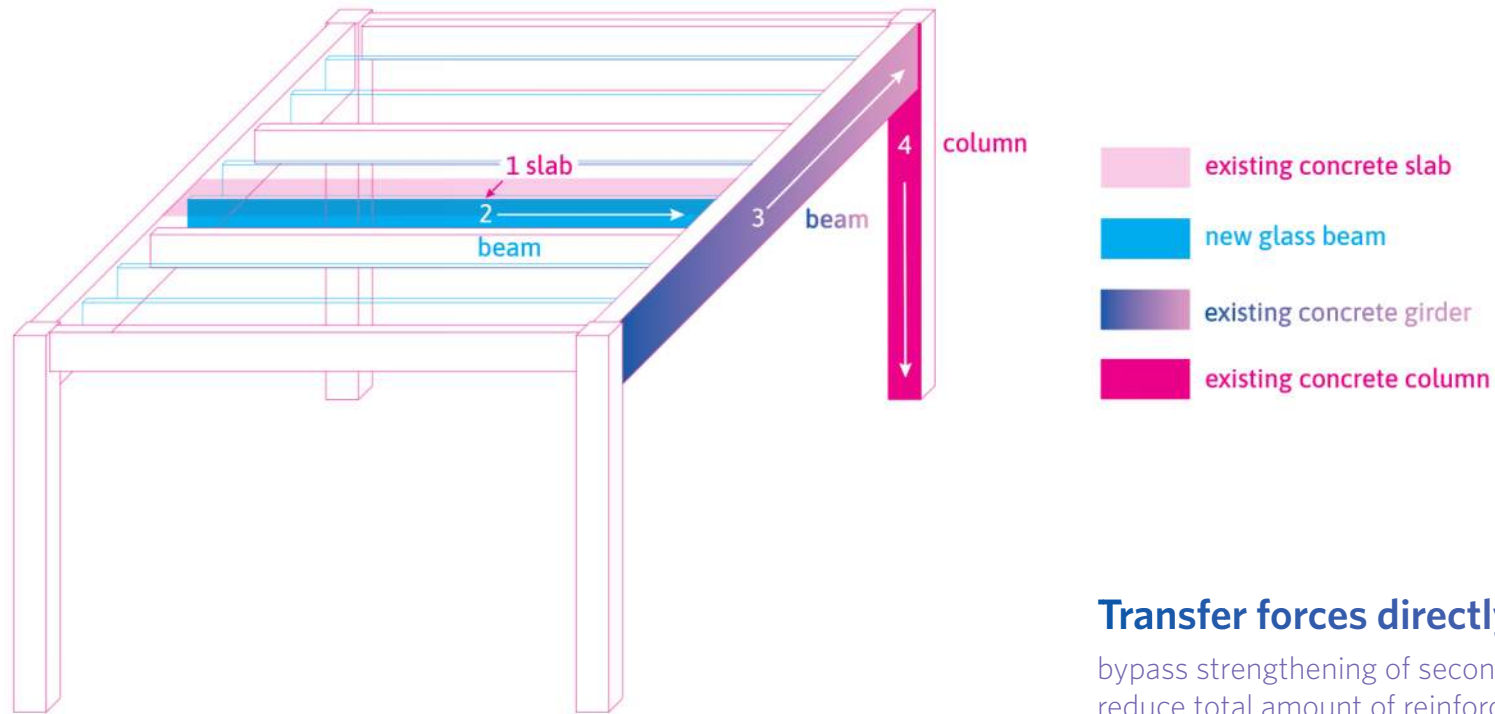

Transfer forces directly to girder:

bypass strengthening of secondary beams
reduce total amount of reinforcement required

DESIGN STUDY 2 / CONFIGURATIONS PER USE

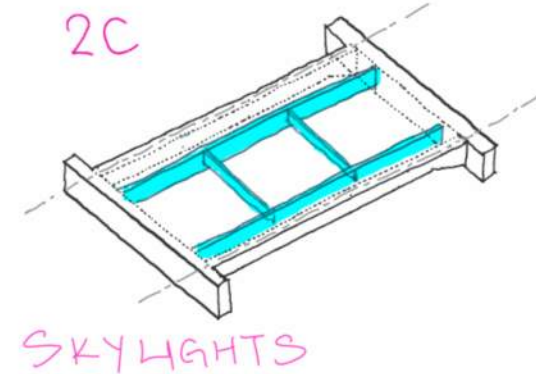
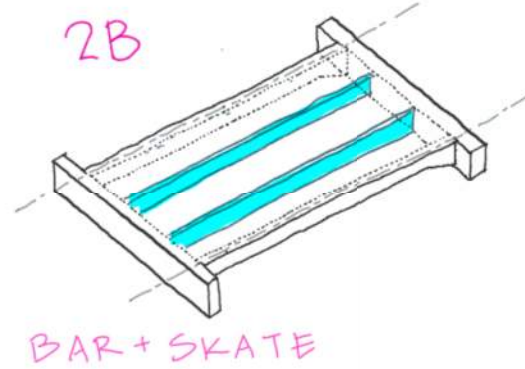
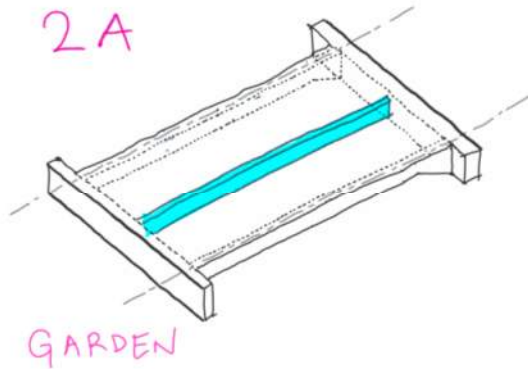
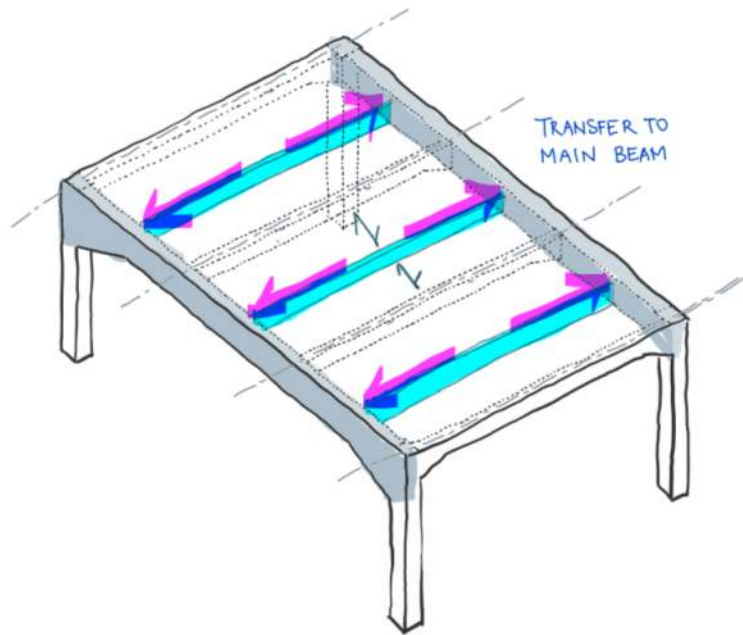

NEW GLASS BEAM

EXISTING CONCRETE

DESIGN STUDY 2 / CONFIGURATIONS PER USE

	Q_{ULS}	Geometry	Configuration
Roof Garden	11.42 kN/m	84x410 mm 7-ply x 12 mm	
Skatepark	12.98 kN/m	84x450 mm 7-ply x 12 mm	
Cafe/Bar	15.36 kN/m	84x500 mm 7-ply x 12 mm	

DESIGN STUDY 2 / EXISTING BEAM STRENGTHENING

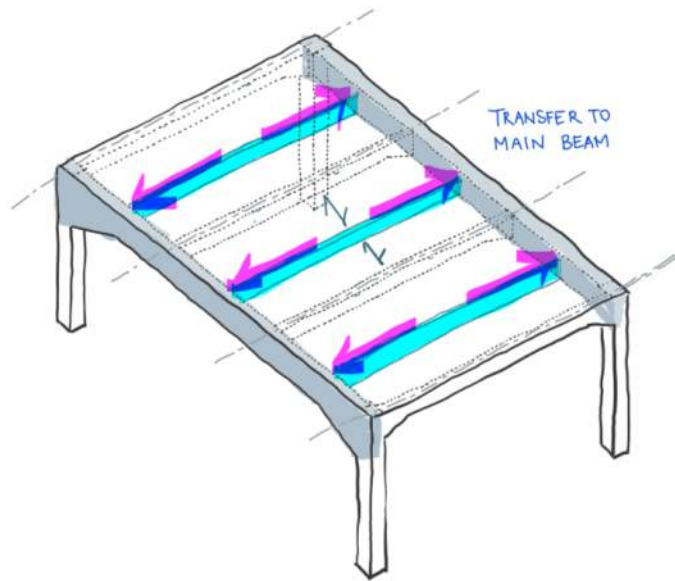

Original utilization of girder: 0.41

4.98 kN/m²

Utilization with new loads added:

Garden	1.27
Skate	1.40
Bar	1.61

DESIGN STUDY 2 / EXISTING BEAM STRENGTHENING

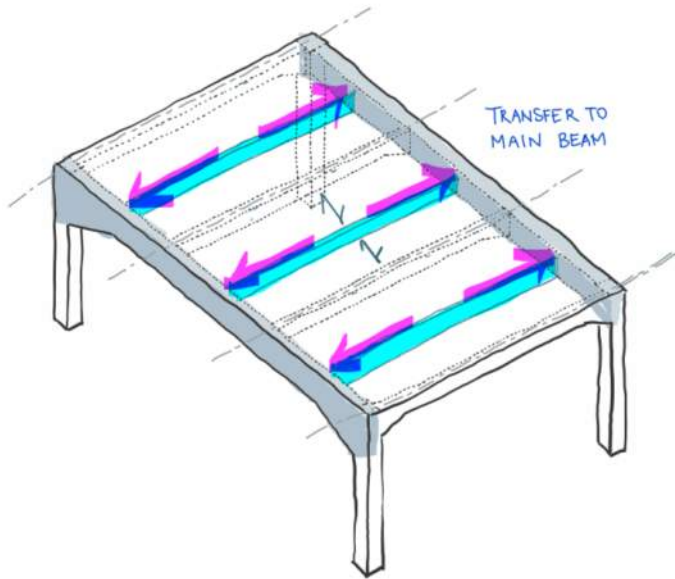

Original utilization of girder: 0.41

4.98 kN/m²

Utilization with new loads added:

Garden	1.27
Skate	1.40
Bar	1.61

MIGHT BE OK WITH FRP

***USE STEEL,
ADD COLUMNS?***



4. ASSEMBLY

DETAILING + CONNECTION DESIGN SHOULD BE:

1. reversible
2. no holes in glass
3. do not remove substrate material
4. mechanical connections

RAISE + BOLT BEAM ENDS TO EXISTING CONCRETE BEAM

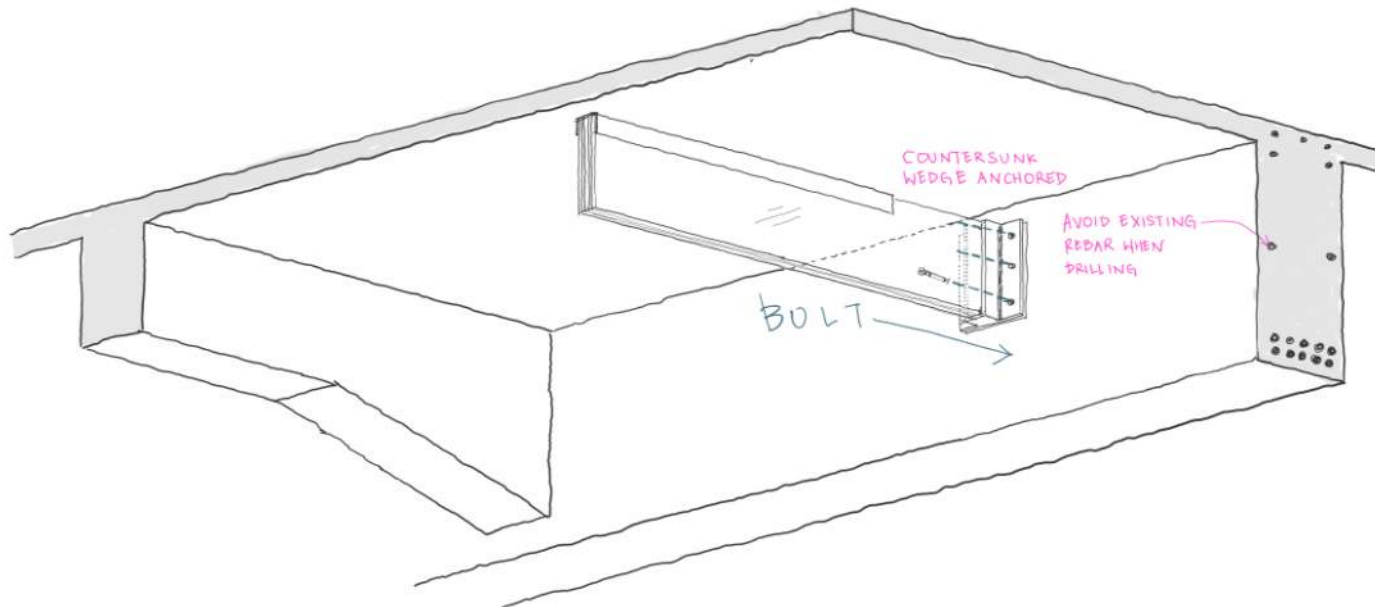
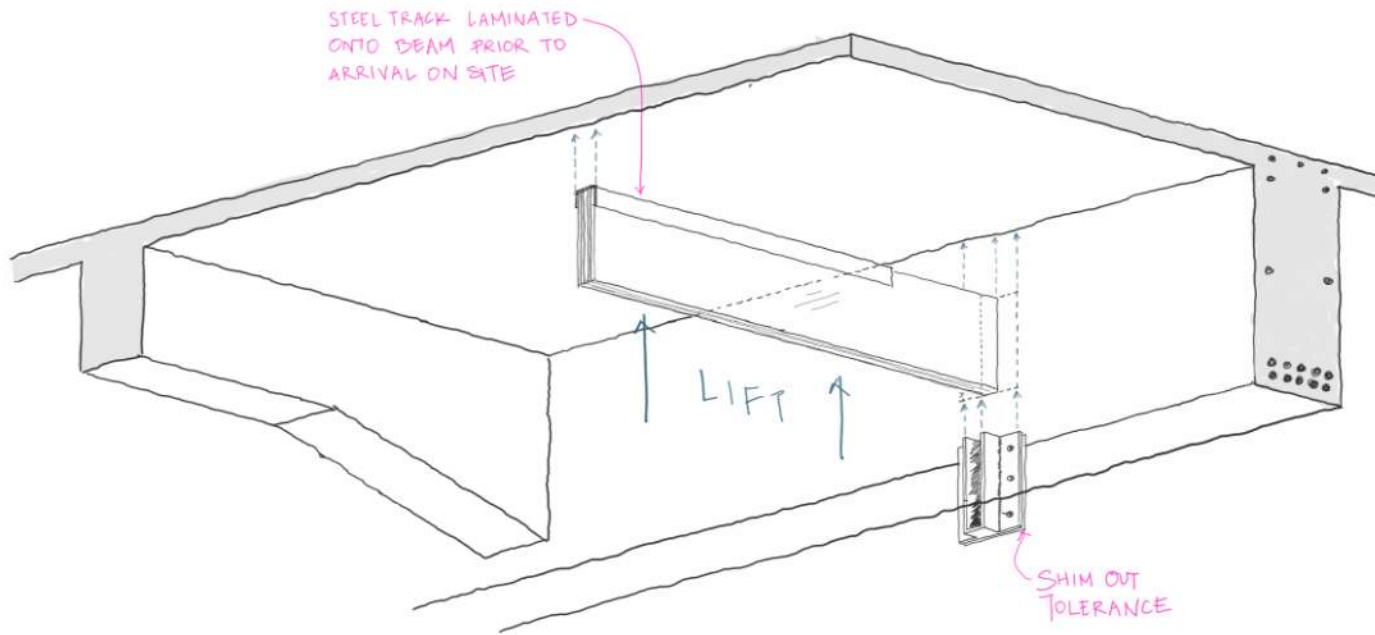

BOLT STEEL ANGLES TO SLAB, MORTAR BETWEEN GLASS AND CONCRETE

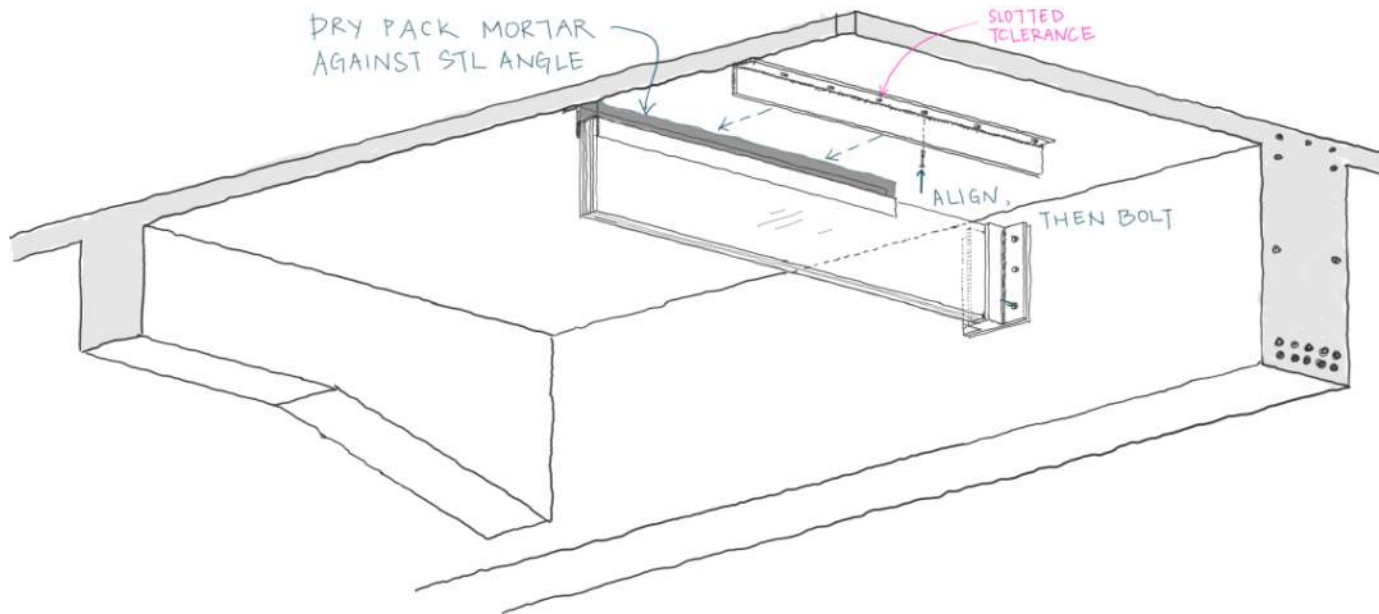
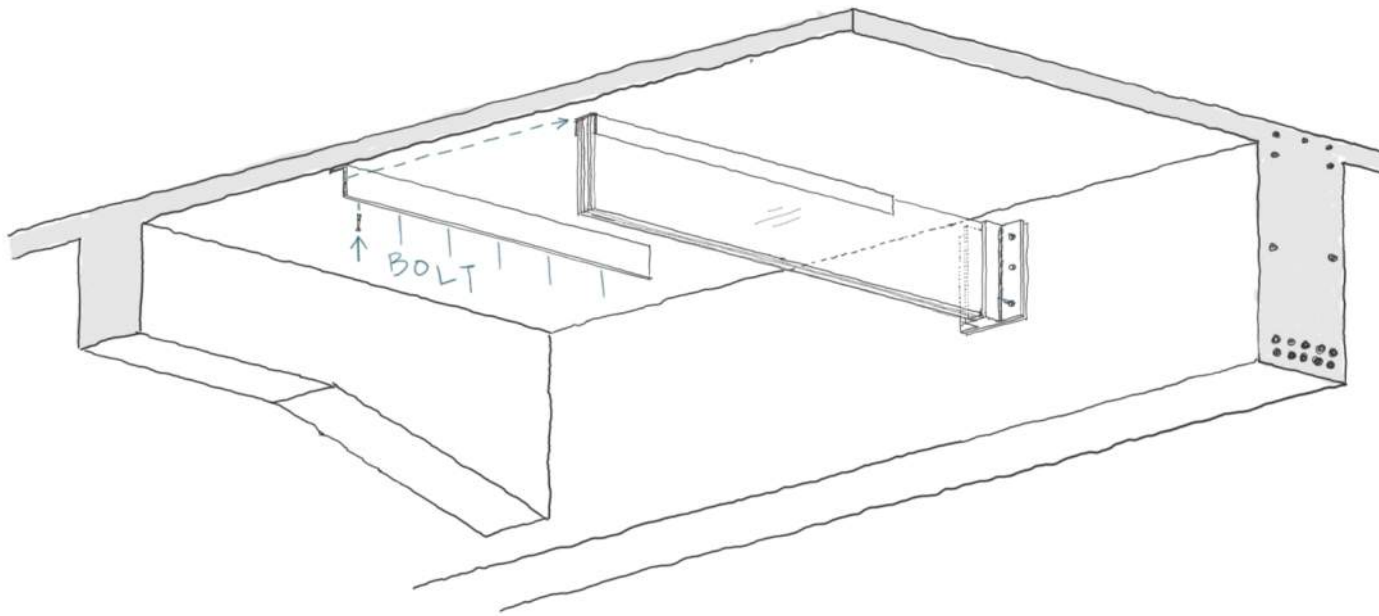

REVERSE INTERVENTION

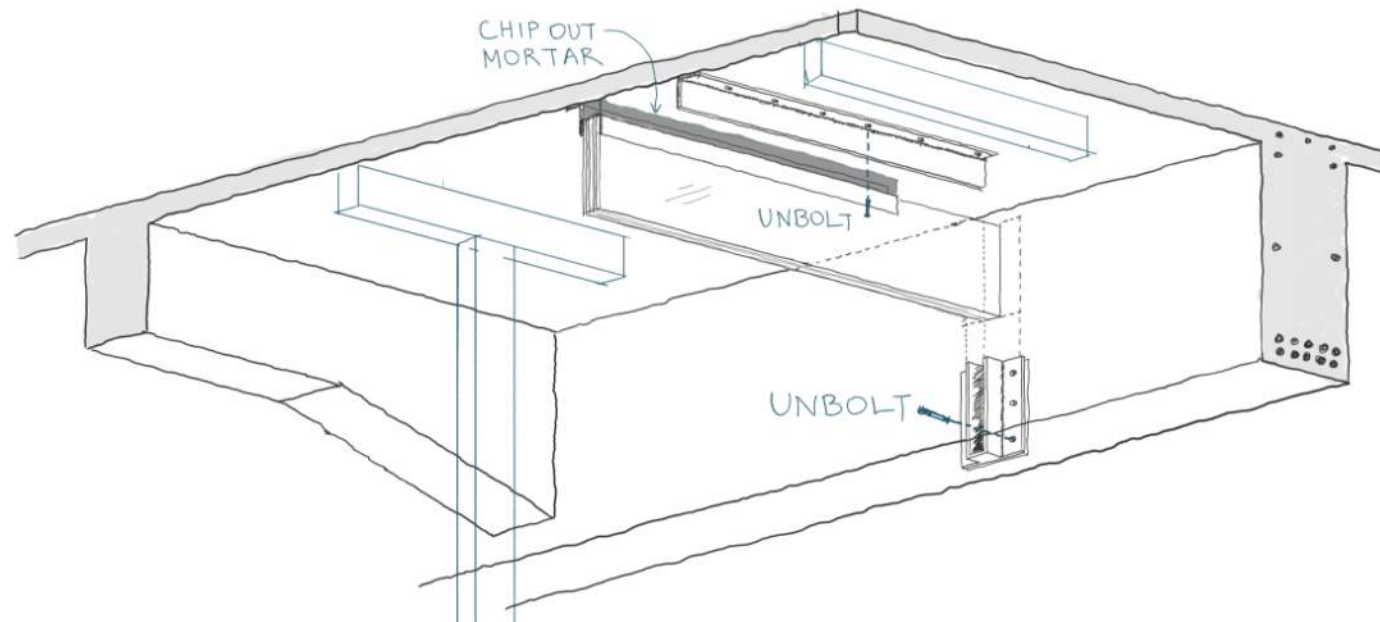
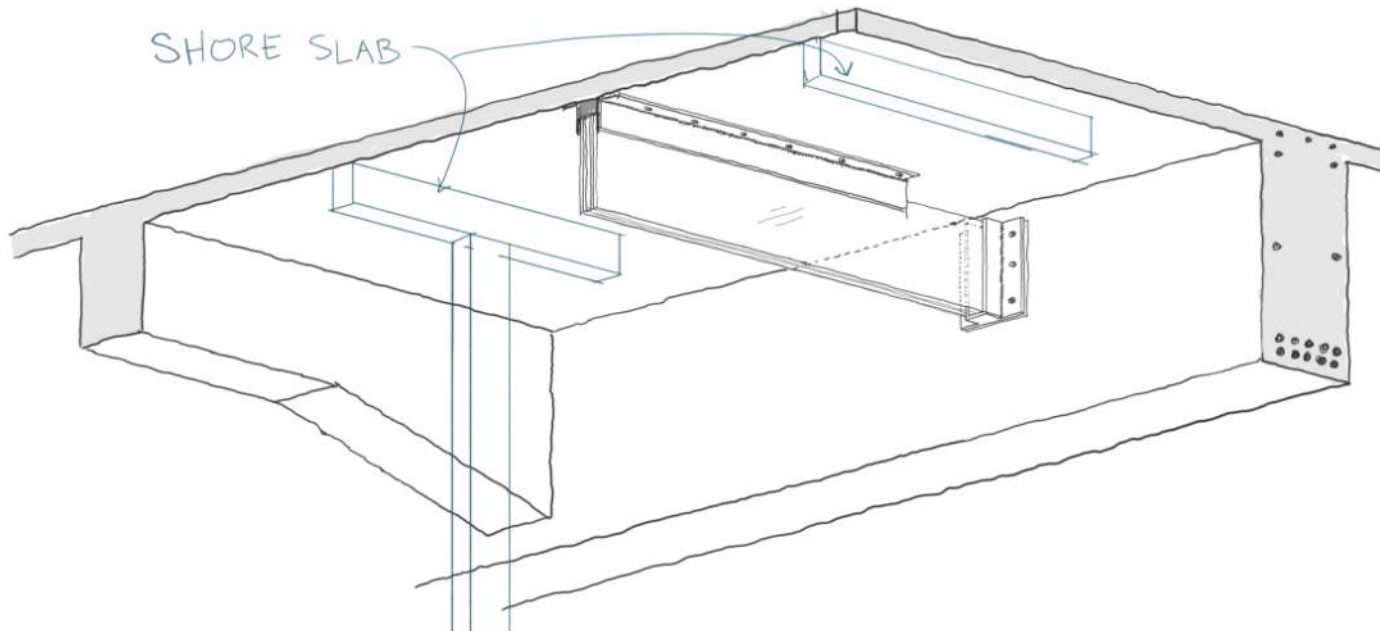

SUMMARY

Existing concrete structure

- slab section and reinforcement governs capacity
- some room for increase in beams and girders
- even though large dimensions, low strength concrete [L1 loads not as high as originally designed]

Layout

- secondary beams not enough capacity to hold new loads
- girders have most excess capacity: redirect new loads here
- bias toward glass-concrete connections for sake of simplicity in installation
- use more beams with smaller sections for redundancy at congregation areas

Existing beam strengthening

- at least the girders must be strengthened
- this could mean FRP, new steel elements, new columns, separate structures

Glass design

- monolithic and rectangular section
- laminated HS glass for strength and residual capacity at fracture
- plies no thicker than 15mm
- fire generally mediated through addition of sacrificial layers

Composite vs. not

- material savings of 30-40% when acting as fully composite but this requires sufficient anchorage
- more anchorage may result in more steel components, affecting aesthetic

RECOMMENDATIONS

Verify assumptions

- determine whether columns and foundations would require strengthening
- evaluate materials for strengthening existing elements and whether it should be glass

Study composite

- connection design to allow fully composite action
- if in historic buildings, fastener should also be reversible

Section design

- develop options other than monolithic glass
- optimize geometry
- try reinforcement with other materials or post-tensioning

Fire resistance

- determine whether backup transfer mechanisms should be in place
- how to protect sides and bottom of beam from cracking due to high heat

Experimental testing

- test preliminary designs on substrate replicating existing condition
- ideally test on actual building pieces
- compare to calculations and modelling

GLASS

that

STRETCHES
FLOORS,

FACILITATES
CONTACT

and

TALKS
STORIES

