

Automated Tracking, Inspection and Commissioning of Wall Panels Using an IoT-Blockchain Solution The Case of ETICS

Tagliabue, Lavinia Chiara; Rinaldi, Stefano; Hunhevicz, Jens; Melchiori, Michele; Hall, Daniel; Cairoli, Maria; Cirbini, Angelo Luigi Camillo

DOI

[10.35490/EC3.2024.314](https://doi.org/10.35490/EC3.2024.314)

Publication date

2024

Document Version

Final published version

Published in

Proceedings of the 2024 European Conference on Computing in Construction

Citation (APA)

Tagliabue, L. C., Rinaldi, S., Hunhevicz, J., Melchiori, M., Hall, D., Cairoli, M., & Cirbini, A. L. C. (2024). Automated Tracking, Inspection and Commissioning of Wall Panels Using an IoT-Blockchain Solution: The Case of ETICS. In M. Srećković, M. Kassem, R. Soman, & A. Chassiakos (Eds.), *Proceedings of the 2024 European Conference on Computing in Construction* (pp. 66-73). (Proceedings of the European Conference on Computing in Construction; Vol. 2024). European Council on Computing in Construction (EC3). <https://doi.org/10.35490/EC3.2024.314>

Important note

To cite this publication, please use the final published version (if applicable).
Please check the document version above.

Copyright

Other than for strictly personal use, it is not permitted to download, forward or distribute the text or part of it, without the consent of the author(s) and/or copyright holder(s), unless the work is under an open content license such as Creative Commons.

Takedown policy

Please contact us and provide details if you believe this document breaches copyrights.
We will remove access to the work immediately and investigate your claim.

AUTOMATED TRACKING, INSPECTION AND COMMISSIONING OF WALL PANELS USING AN IOT-BLOCKCHAIN SOLUTION: THE CASE OF ETICS

Lavinia Chiara Tagliabue¹, Stefano Rinaldi², Jens Hunhevicz³, Michele Melchiori², Daniel Hall⁴, Maria Cairoli⁵ and Angelo Luigi Camillo Cirbini²

¹University of Turin, Turin, Italy

²University of Brescia, Brescia, Italy

³EMPA, Zurich, Switzerland

⁴Delft University of Technology, Delft, Netherlands

⁵Politecnico di Milano, Milan, Italy

Abstract

Poor installation and misaligned supply chain incentives can impact the energy performance and user comfort of External Thermal Insulation Composite System (ETICS) panels. This paper investigates a combined IoT-blockchain solution to create trusted traceability of the process, together with performance-based incentives based on sensor data about the panel state. The system is implemented on the University of Brescia prototype, an experimental test house. The results demonstrate the feasibility of an integrated system of smart contracts, IoT sensors and a digital twin for visualization. The work provides insights into an IoT-blockchain solution applied to a real-world use case for supply chain process improvement.

Introduction

Tracking of the state of health, inspection, and commissioning of installed components in the built environment has traditionally been a manual process. Tracking of progress depends on visual inspections, checklists, and logs to report deficiencies. Traditional practice relies heavily on inspectors' personal judgment and observational skills (Boschè et al., 2015). More recently, a huge body of work has emerged for automated monitoring of operation-level construction progress, using technologies such as laser scanning, computer vision and/or Building Information Modeling (BIM) for many applications, for example mechanical, electrical and plumbing systems or concrete floor flatness.

Another large field of research is the automated commissioning of buildings to show that they follow the promised energy performance (Panteli et al., 2020). Related research for facility management focuses on the real time monitoring through visualization at building and city scale, energy performance analysis, and energy benchmarking (Tomašević et al., 2015). Using these solutions, facility managers can retrieve energy-related information from the Building Management System (BMS) and view the BIM information using web-based energy management platforms (McGlenn et al., 2017). This allows facility managers to better visualize indoor environmental conditions such as temperature and humidity and make adjustments to improve user comfort (Marzouk and Abdelaty, 2014).

Other energy related solutions include the energy performance analysis based on real time data. Typically, energy analysis is based on mathematical simulation methods in the 3D environment; however, there is often a gap between predicted and actual building performance. Moreover, the likelihood for performance disparity increases in cases of complex, high-performance features which are difficult to model and simulate. However, one promising solution to improve accuracy of prediction versus performance is to use technologies to enable real time data as calculation input for the energy analysis (Yilmaz et al., 2023).

Despite advances in these research areas, solutions for progress tracking and commissioning technologies often mirror the fragmentation found in the greater industry (Hall et al., 2020). The proposed solutions tend to be oriented around individual project temporal phases: installation, inspection, and commissioning. Solutions are developed in isolation for tracking the installation, automating the inspection, or checking the commissioning. By contrast, much less research looks at integrating these activities with an object- or component-oriented perspective.

Monitoring these activities at the component level has several advantages. It avoids misaligned incentives where firms attempt to push risk down the supply chain. Better supply chain management of the digital asset can occur across the lifecycle and enable new incentive systems and business models for management of the asset, including opportunities for sustainability (e.g., circular economy), productivity (e.g., better collaboration, streamlined value chain) and/or security (e.g., the Hackett fire in London) (Watson et al., 2019).

Industry 4.0 for Lifecycle Traceability

The concept of "industry 4.0" is used to describe digital technologies and automation to create interconnected, intelligent, autonomous, and self-learning cyber-physical systems (Lasi et al., 2014). In the Architecture, Engineering, Construction, and Operations (AECO) industry, the term "Construction 4.0" is emerging (Klinc et al., 2019; FIEC 2015; Sawhney et al., 2020; Garcia de Soto et al., 2019). While Construction 4.0 encompasses many concepts and technologies, multiple sources mention the combination of BIM, Internet-of-Things (IoT) sensors, and distributed ledger technologies (DLT,

also referred to as blockchain) as a favorable combination to enable supply chain traceability and data integration (Ye et al., 2018; Kinnaird and Geipel, 2017). BIM allows designers and builders to design, visualize, and coordinate construction systems with greater efficiency using three-dimensional digital models and processes.

BIM have proven that generation of large data sets in the AECO industry is possible. It has triggered a change towards digital working practices across stages of the design, construction, and operations process.

IoT refers to a network of sensors and connected devices that can be used for real-time feedback. To reduce the gap between the digital and physical world digital twins can act as (often) visual representations of information based on sensors for real-time representation of the physical world. For example, Zhai et al. (2019) finds that sensors in the construction process, in tandem with BIM, can help to address problems of inconvenient data collection, lack of automatic decision support, and incomplete information.

DLT and associated blockchain technologies can be an important enabler for more transparent and streamlined traceability in the AECO industry (Li et al, 2020). DLT enables direct peer-to-peer transactions of value and the immutable and trusted storage of data. These properties facilitate the building of trust between transacting parties and devices and can decrease the settlement time of transactions and reduction of costs associated with intermediaries (Viryasitavat et al., 2018). In addition, newer implementations of blockchain allow the execution of code protocols, often called smart contracts (SCs). SCs can encode business logic for value transactions and data handled on the blockchain to create automated workflows. Since these code protocols live on a blockchain, they benefit from the immutability and transparency of the system and hence it is ensured that they execute exactly as specified. Two studies critically analyzed blockchain for construction applications, concluding that the technology indeed has real world potential beyond the hype (Hunhevicz and Hall, 2020; Perera et al., 2020).

Supply chain traceability has been identified by several studies as one of the most promising ones for the application of DLT (Hunhevicz and Hall, 2020; Perera et al., 2020; Li et al., 2019). The opportunity is best described by Qian et al. (2020), who conclude that “blockchain technology is a key technology in Construction 4.0 that can bring the cyber (digital technologies) and physical (social capital) closer together by transforming trust to support various ecosystems of construction supply chains that shape and produce the built environment.” However, overall there is a need to further investigate how the combined use of DLT, IoT and BIM should be implemented to create a system of trusted life cycle traceability and incentives.

Scope and Methodology

The goal of this research is to develop a tracing and performance monitoring system, leveraging combined use of new Industry 4.0 technologies, in particular BIM,

IoT and blockchain. The innovation hereby lies in applying blockchain to the complete life cycle, beyond track and trace of just one supply chain stage. Furthermore, there is an opportunity to couple the performance evaluation through sensorized components with the benefits of trusted blockchain traceability and payments.

Research Setting

To achieve this goal, the study works with the supply chain for the retrofitting process using an External Thermal Insulation Composite System (ETICS). ETICS panels are widely used in retrofitting intervention to enhance the energy performance of the existing building. Correct installation of ETICS is important for a functioning insulation system to achieve the planned energy performance, having a direct impact on the cost of operation and comfort of inhabitants.

However, the current installation of ETICS is subject to repeated failure. ETICS represents an exemplary case for the often-present life cycle related issues in the construction supply chain. The success of the ETICS installation depends on different contractors that need to do their due diligence to deliver the final expected performance. The contractor is incentivized to maximize their profit during installation by taking “shortcuts” to save on material or time. Failures during production or installation manifest often, but they are not discovered until the operations phase because ETICS panels remain hidden behind the façade until the failure is propagated to the surface. This time discrepancy makes it very hard to investigate the exact cause of failure, as well as to hold the responsible parties accountable. The installing parties may pass blame to others, may have gone bankrupt, or the warranty time may have already expired.

A careful tracing and performance evaluation of ETICS panels over the course of their life cycle could benefit 1) the environment through emission reduction and recyclability of the material related to the concept of circular economy, 2) the operational efficiency through cost reduction both in heating or cooling losses and warranty claims, and 3) health and safety of both workers and occupants of the retrofitted building.

Implementation of a BIM-IoT-DLT approach is particularly suitable for the ETICS case study because: 1) it has a specific product focus that can be tracked, inspected, and commissioned; 2) the supply chain of ETICS panels has been repeatedly identified as a typical example where stakeholders misbehave at different working steps for their own benefit, to the detriment of the overall system performance. DLT can provide the trusted traceability to ensure accountability regarding correct production, commissioning, and installation, and incentivize correct installation through performance-based payments.

Case Study Description

This study uses the so-called “University of Brescia (UniBS) Prototype” as a research case study. The UniBS was built to investigate different improvement potentials

around the lifecycle performance of ETICS. The physical prototype consists of a small demonstrator-house realized at the experimental facilities provided by Ente Sistema Edilizia (Building System Institute) Brescia, within a collaborative framework involving both the academia and industry. The research program was managed with the support of an industrial manufacturer Weber Saint-Gobain. The driving force from academia was the eLUX lab–“Energy Laboratory as University eXpo” at the smart campus of the University of Brescia in Italy, led by the Department of Civil, Environmental, Architectural Engineering and Mathematics and the Department of Information Engineering.

UniBS is equipped with detailed network of IoT to provide real time data on the ETICS performance. The UniBS prototype served as the test platform, applying the developed technical system throughout the life cycle of the prototype, from construction to operations.

The next section of the paper further specifies the role of the investigated ETICS supply chain workflow in the UniBS prototype, and the implemented blockchain process. The results section then gives details on 1) the transaction and SC design logic and implementation of the DLT-based system for the case study, and 2) the connection of the DLT SC with the digital twin and the IoT system for performance evaluation.

Blockchain for ETICS supply chain tracking

The main two value propositions of DLT in this prototype are 1) the transparency and immutability it can provide to track the ETICS panels and associated transactions in the supply chain, 2) workflow automation throughout the supply chain process for the execution of the performance-based incentive payments. The first one is important to establish a trusted database that can hold parties accountable for their actions, as well as assurance that data integrity is maintained. The second one can then create (semi-)autonomous workflows and automatic triggering of payments without any intermediary. Below we outline the investigated workflow of the ETICS panels, and afterwards give more details on the implemented blockchain process.

Investigated Workflow

Figure 1 pictures the overall workflow logic of the ETICS value supply chain for the UniBS Prototype with its involved stakeholders. To implement blockchain for the UniBS Prototype, the supply chain was simplified regarding both the number of actors and the workflow steps. The real supply chain is more extensive, nevertheless, this approach can showcase most important aspects to investigate a blockchain implementation. The considered actors involve the supplier of the ETICS panels, a contractor responsible to install the panels on the construction site, as well as the building owner.

Moreover, there is an actor introduced called “Oracle”. The term oracle usually describes an external source of information that is needed to feed information to blockchain based SC. For the UniBS Prototype, the Oracle is a placeholder name for actors that will take the

role of verifying various aspects regarding the energy performance-based contract. In the example of this paper, to feed the verification data of the installation steps (Figure 1; (7)) the Oracle is a trusted human third-party actor, while for the commissioning (Figure 1; (10)) the Oracle consists of the sensor network. To have both a human actor and sensors as an Oracle can also showcase these two possibilities in comparison. Having said that, not all SCs used in the prototype need input from external sources. Some of them only rely on the information saved on the blockchain itself. For example, accessibility features and users’ roles, as well as the prescribed supply chain flow and the actual state of each panel can be described and checked on-chain. More information on the different SCs implemented in the prototype is given in the next section.

Implemented Blockchain Process

The blockchain-based process follows the defined workflow of the panels as defined in Figure 1. The smart contract logic controlling the access rules and the sequence of actions is then based on the “state” of panels. For example, the workflow starts with registering panels through the supplier once they are produced (Figure 1; (1)). The state is then “produced”. This indicates to the SC that the next step needs to be selling the panels to the owner with a subsequent payment (Figure 1; (2), (3)). The workflow goes on to ship the panels to the construction site (Figure 1; (4)), where the contractor will receive and install them (Figure 1; (5), (6)). At this point, the SC only allows the payment and subsequent use of the panels in the state “installed” if all the installation checks are

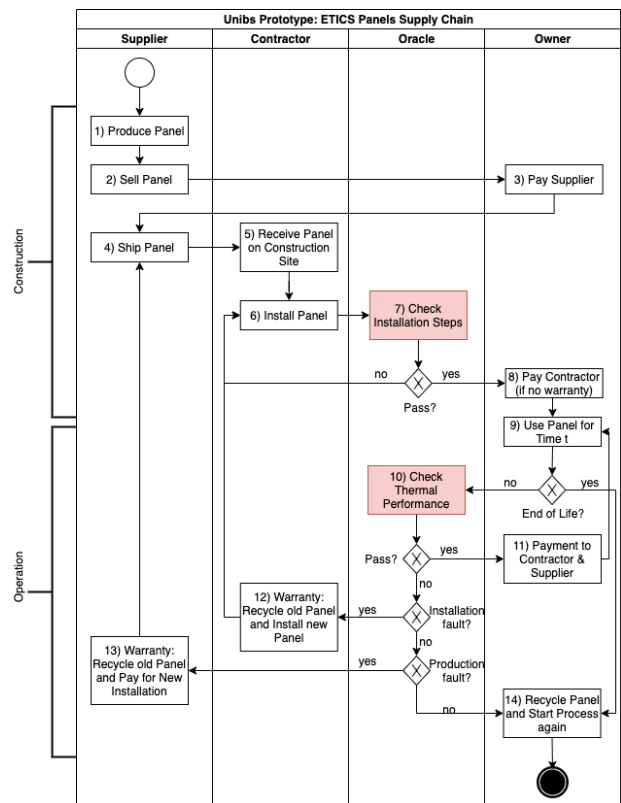

Figure 1: Flow chart of the ETICS Panels Supply Chain in the UniBS Prototype.

successful. This ensures verifiability and certification of the installation steps. For the use phase, the SC request for each time interval t the sensor data to check the thermal performance of the ETICS system (Figure 1; (9), (10)). If the situation is as expected, a payment to both the contractor and the supplier is automatically triggered (Figure 1; (11)) and the procedure repeats until the end of life of the panel is reached (Figure 1; (14)). In case the thermal performance of the ETICS is not as expected, the SC logic runs through the various causes, while considering the installation certification. In case it is an installation fault, the warranty and reinstallation of the panels needs to be performed through the contractor (Figure 1; (12)). In case of a production fault, the warranty to install a new ETICS panel needs to be paid by the supplier (Figure 1; (13)).

Overall, the proposed workflow acts as an energy performance smart contract (EPSC) and extends the liability of the supplier and contractor into the operational phase. Stakeholders get paid as usual to cover their immediate expenses, but only receive profit if the solution performs well during operation through an automated and continuous revenue stream. The blockchain smart contract gets funded up front by the owner and therefore acts as an escrow. If the solution does not perform well, the stakeholders will receive less or no profit. This should act as an incentive to collaborate and integrate across the life cycle phases. If behaving honestly, all participants can benefit from such a solution. The supplier has data available on where the panels are installed and how they perform. The owner gets assurance on the production an installation quality, as well as automatic warranty claims based on real-time sensor data. The contractor can benefit from the constant additional revenue streams but could also be held accountable for mistakes and warranty claims. Through the transparent installation certification, the contractor can also proof later that the installation was correct, but maybe a production error.

Implementation and Results

Transaction, SC Design and DLT-based system

The core of the implementation of the ETICS DLT-based system consists of a set of SCs supporting trust-demanding tasks developed for the Hyperledger Fabric permissioned blockchain infrastructure. Since not every task and data can benefit from on-chain execution, we defined a rule-based approach to identify these trust-demanding tasks and data objects. In general, these tasks identify critical activities in the workflows, with associated data objects, as explained above. A Private permissioned blockchain was chosen because it offers privacy and all parties are known (Hunheviz and Hall, 2020). However, a permissionless blockchain could also be utilized, provided that appropriate encryption measures are implemented for the data written on it.

The Hyperledger Composer, a rapid prototyping environment running on top of Hyperledger Fabric, was used as development environment. The main concepts of a Hyperledger Composer project are *participant*, *asset*,

transaction and *event*. An asset is anything, whether physical or virtual having some value in the considered domain. A participant is a role of the workflow who participates in the operations on the ledger. A transaction is an operation submitted by a participant to modify the ledger. It may consist of modifying the amount of an asset and it may raise events. A transaction typically modifies or creates some contents of the Hyperledger world state. Implementing a Hyperledger Composer project (M.M.S. et al., 2019) consists of creating three main files. A model definition (with extension .cto) file describes the business domain. It is written in a specific notation, called Composer Modeling Language, in which resources like participants, assets, transactions and events are declared. A JavaScript file, in which transactions declared in the .cto file are implemented as functions, describes the way assets are processed. Finally, a file containing a list of access control rules defines the rights (e.g., Read, Create, Update) assigned to each participant to operate on the ledger. These files form the so-called Business Network definition. For example, the following shows both the definitions of the *Owner* participant and the *Building* asset in the model definition file:

```
participant Owner extends Company {
  o String name
    o String contactInfo optional
}
asset Building identified by buildingID{
  o String buildingID
  --> Design[] referencesToDesign
}
```

Here, the definition of the *Owner* participant extends the *Company* super-type. The resource has all properties and fields specified by the super-type and may add additional properties from its own definition. The definition of the *Building* asset includes the identified attribute *buildingID*. A resource definition specifies a set of relationships to other types that are not owned by the resource but that may be referenced from it. In this example, *Building* references a set of objects of *Design* type.

In our implementation, the participants can make an authentication on the ledger and perform the operations they are authorized to by the access control rules. The assets are the objects that the transactions operate on. We developed two kinds of transactions. The first one updates the ledger world state. The second one permits to create instances of assets (e.g., to insert a new panels installation on the ledger).

```
async function terminatePosing( tx ) {
  const NS = 'com.biz.eticssample';
  const factory = getFactory();
  const dateTime = new Date();
  const panRegistry = await getAssetRegistry('com.biz.eticssample.installations');
  const instConfirmation =
  factory.newResource(NS, 'instconfirmations', tx.id);
  instConfirmation.EndingDate = dateTime;
  instConfirmation.anchorsPattern = tx.anchorsPattern;
  instConfirmation.building = factory.newRelationship(
  NS,'building',tx.building);
```

```

instConfirmation.contractor = factory.newRelationship
p(NS,'contractor',tx.contractor);
await panRegistry.add(instConfirmation); }

```

The above function *terminatePosing* defined to process a transaction, exemplarily showing transaction execution. This transaction is declared in the model definition file and represents the corresponding workflow task. It permits to a contractor to create an *installationConfirmation* object sets its properties (i.e., date and time, pattern used for panel anchors, references to the building and to the contractor), and to add it to the ledger. The parameter *tx* is an instance of the *terminatePosing* function.

SC, IoT and DT for Commissioning of ETCIS Panels

The proposed system leverages IoT sensors to continually gather data on the condition of panels throughout their operational lifespan, enriching the Digital Twin (DT) model of the building. This integration allows for real-time monitoring of ETICS health. BIM is employed to facilitate intuitive visualization for building managers. Moreover, it serves as a proactive tool, triggering alarms promptly in response to any detected anomalies or critical events, with respect to the expected behavior. To assess the performance of the ETICS system during the operational phase, it is important to have a base for comparison (expected values). Therefore, an energy model was used to simulate the thermal behavior of the system. The purpose is to provide a predictive model of the energy flow that is transferred from inside (where a heating system in winter set up the temperature to 20°C) to the external, passing through the ETICS consisting of the materials EPS and glass wool. The model allows to calculate the expected temperature in the interface between the wall and the insulation layer defined by the boundary conditions through the heat transfer equations implemented in the dynamic simulation (Energyplus).

The temperature profile in the wall has been then defined in the calculation model and depicted in Figure 2. The sensor for measuring temperature and relative humidity should be properly installed in the interspace between the thermal layer and the wall. The calculated value can be then compared to the temperature measured by the sensors. Based on this method, it is possible to assess the deviation of the predicted value compared to the temperatures measured by the sensors on the control walls (north, west), as well as the temperatures on the failing walls (south, east).

The deployment of a distributed monitoring system could make the analysis of the energy efficiency and the maintenance state of an installed thermal insulation system. Such a system should be able to monitor in real-time several parameters from which can be inferred key performance indexes (KPIs) about the status of the building thermal coating. In particular, the monitoring system should be able to identify the following conditions: i) partial detachment of the insulation panel; ii) change in the energy efficiency of the coating detected by the temperature in the interface between the wall and the insulation panel and due to water infiltration for

example. The monitoring system should be easy to install, low-cost and robust since it must be installed on the external wall.

Battery-operated devices are preferred to cabled ones, because they are easier to install. In addition, the monitoring system should have a lifetime comparable with the installation to monitor, i.e. approximately around 10/20 years. Thus, the system should be formed by devices with low power consumption, to guarantee a useful lifetime. Given these considerations, the monitoring system exploits the Wireless Sensor Network (WSN) approach for extensive monitoring of the parameters. Each of the monitoring points is composed of a wireless sensor, able to collect the parameters using transducers. Each of the sensors should monitor the temperature and the relative humidity (used to estimate the efficiency of the ETICS), and the 3-axis acceleration (used to estimate the partial detachment of the ETICS). The estimation of energy efficiency requires the estimation of the external and internal temperature and relative humidity. The block diagram of the sensor board is shown in Figure 3. Each sensor board is composed of three types of transducers: a temperature sensor, a 3-axis

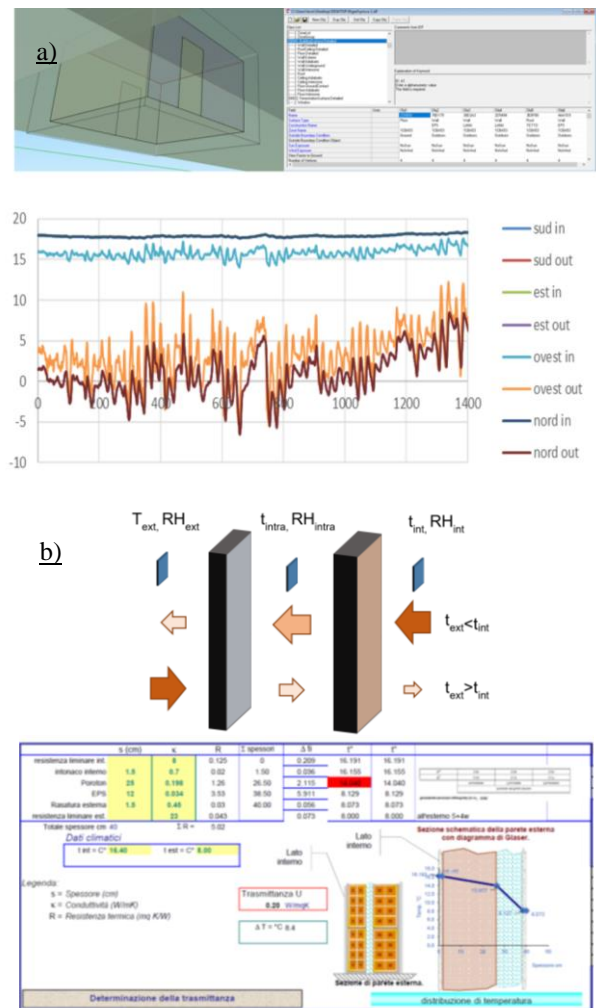

Figure 2: Calculation Method: a) Energy model of the test house b) Assessment of the expected sensor values.

accelerometer, and a relative humidity sensor. The data generated by the transducers are acquired and processed by the Micro Controller Unit (MCU). The data are temporarily stored in the MCU and, when possible, transmitted to a remote gateway through a Bluetooth Low Energy (BLE) modem. The MCU is also responsible for the optimization of the energy consumption of the entire board, through the adoption of proper low-power policy. All the peripherals of the board, including the transducers and the BLE modem, are turned off and the MCU itself remains in deep sleep mode until a data transmission is scheduled. The wake-up of the sensor board is obtained using the wake-up peripheral of the MCU. Each of the boards has been programmed to wake up every 3 hours, to reduce energy consumption. After the wake-up, the MCU acquires the data from the transducers and transmits the data through the BLE modem. The BLE protocol defines several communication modes, which require a data exchange with the local network coordinator. Such communication modes are not suitable for applications with strict requirements on power consumption. BLE provides a communication mode that does not require any interaction with the network coordinator: the advertising. Advertising packets are sent by a BLE node to advertise its presence to the coordinator. An advertise packet contains the Universally Unique Identifier (UUID), which identifies the sending node, and up to 37 bytes that can contain custom data. In the current case, the custom bytes are used to transmit the transducers' data, i.e. temperature, relative humidity, and 3-axis acceleration. The prototype of the sensor has been realized using the CC2650 Sensor Tag prototype board produced by Texas Instruments. Each of the boards is equipped with a high-performance ARM Cortex-M3 CC2650 wireless MCU, a 9-axis movement transducer (3-axis accelerometer, 3-axis gyroscope, 3-axis magnetometer), and a humidity transducer, able to monitor both relative humidity and temperature. The complete list of transducers used in the prototype and their main characteristics are summarized in Table 1.

Table 1: List of the transducers used by the prototype of the sensor board.

Sensor Type	Measurand	Bit resolution	Device
Movement	3-axis Acceleration, 3-axis Magnetometer, 3-axis gyroscope	16 bits	MPU9250
Humidity	Relative Humidity, temperature	16 bits	HDC1000

Each of the sensors installed in the interspace between the insulating layer and the wall represents a node of a Wireless Sensor Network (WSN). Each of the sensors transmits asynchronously the data acquired from the transducers one time every three hours toward the

network coordinator, i.e. the GW in Figure 4. The WSN can be composed of a variable number of nodes. Since a connectionless transmission is used, there is no limit to the maximum number of nodes composing the WSN. The maximum number of nodes composing the WSN depends on the radio coverage and the computational resources of the GW itself. Approximately, is required a GW per each installation. The data acquired by the GW are then transmitted using HTTP RESTful services, through the public network, to a remote server for data processes (the data flow is shown in figure 4).

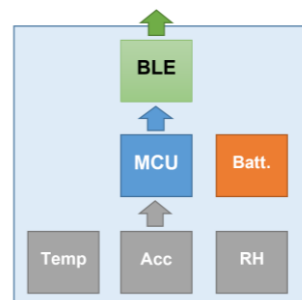

Figure 3: Block diagram of the sensor board. Relative Humidity (RH); Bluetooth Low Energy (BLE); Micro Controller Unit (MCU).

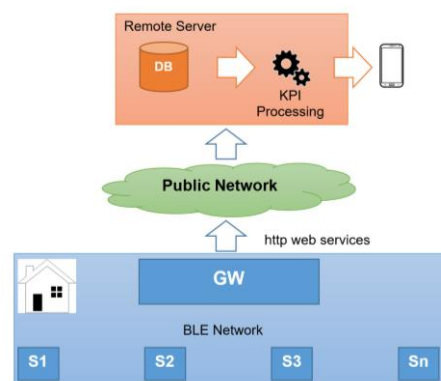

Figure 4: The architecture of the data analysis system.

A NoSQL DB (based on InfluxDB) is used to store the stream of data generated by the sensors. Computational resources are used to process the KPIs using the data stored in the DB. The data and the processed KPIs can be visualized using a dashboard, realized using the Grafana Framework. An example of the dashboard is shown in Figure 5. The proposed system can be easily scaled to process the data coming from different installations. The data from the sensors can be used to inform about the energy performance of the refurbished building and provide insight into discrepancies between the expected performance after the retrofit and the actual situation. The energy model of the building can be used to calculate the expected energy consumption and the temperature measured by the sensor can be used to calculate the energy flow for transmission.

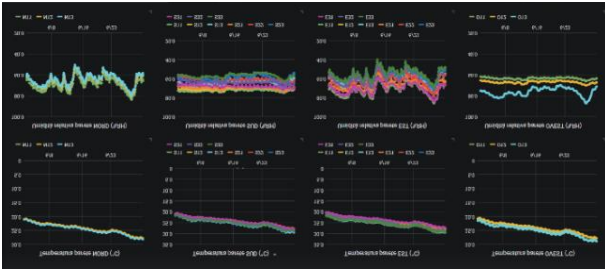

Figure 5: An example of the dashboard used to present the sensor data.

If the values are aligned, a discrepancy in consumption in winter could be related to the ventilation losses and to occupants' behavior for improving IAQ (indoor air quality) to the detriment of the energy saving. On the contrary, if the temperature is lower than expected and the ETICS is not properly insulating, it is possible to activate a detection procedure to understand if an issue is in progress for example for an infiltration which reduces drastically the insulation effect of the material. The experimental information model has been also used as an ideal Digital Twin of the test house working on the data mapping on the walls of the temperature distribution. Through VPL (Visual Programming Language) the sensors created into the information model for the different walls have been connected to the measures database of the value gathered from the sensors and the spread radius of the temperature variation have been visually approximated based on theoretical models since the empirical experience is not possible to exploit (Figure 6). However, the analysis of the data monitored showed that a difference of temperature due to the gradient distribution of the wall is detectable.

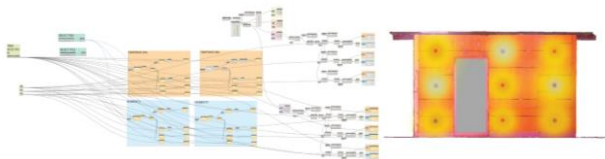

Figure 6: Test house before the installation of the finishing layers when it is possible to see the two target insulation materials, VPL model, and simulation of the spread radius of the temperature variation.

The data coming from the sensors, distributed on the walls, were collected and the difference of temperatures at different installation heights is used to define a sensor-based thermography of the situation of the walls (Figure 7).

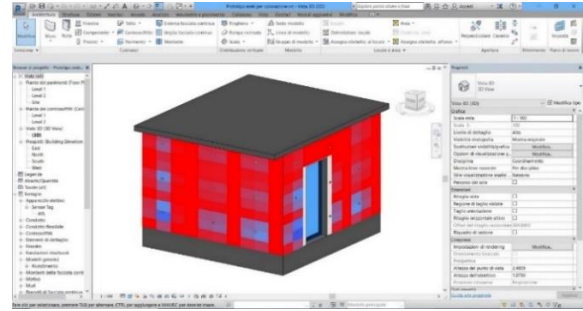

Figure 7: BIM based thermography related to the measured temperatures.

Conclusions

This study demonstrates the significant potential of blockchain technology in the AECO industry, particularly in addressing the challenges of traceability and transparency in supply chain scenarios where trust cannot be guaranteed. Our study focuses on the supply chain of ETICS panels for retrofitting existing buildings, which has been shown to suffer from misaligned incentives throughout the commissioning, installation, and operation of the panels.

Blockchain can provide trusted and transparent tracking of panels for accountability between supply chain actors and can use smart contracts to create performance-based incentive payments for a well-functioning system. For the necessary performance assessment, the sensor enabled IoT solution can provide real-time information over the entire building lifecycle, including the operations and maintenance (O&M) phase.

Our work explores an exemplary implementation of such a combined blockchain-IoT solution, focusing on a lifecycle perspective rather than just parts of the supply chain. We contribute to the emerging number of blockchain-IoT studies that implement energy performance smart contracts (e.g., Hunhevicz et al., 2022). Although the technical implementation and validation was performed on a test building, we believe it can provide valuable insights and inspiration for real-world implementation. Future research could extend to an actual construction project to further assess the cost and performance of the engineered system, compare between different available technical solutions, and evaluate the requirements and impact to industry beyond the focus on technology. Nonetheless, our findings demonstrate how the synergy between blockchain technology and sensor-based solutions can help shape the future of sustainable and resilient construction practices.

References

- Bosché F., Ahmed M., Turkan Y., Haas C.T., Haas R., The value of integrating Scan-to-BIM and Scan-vs-BIM techniques for construction monitoring using laser scanning and BIM: The case of cylindrical MEP components, *Automation in Construction*, Volume 49, Part B, 2015, Pages 201-213, ISSN 0926-5805, <https://doi.org/10.1016/j.autcon.2014.05.014>.

- FIEC. (2015). Construction 4.0. Eur. Constr. Ind. Fed. Retrieved from <http://www.fiec.eu/en/themes-72/construction-40.aspx> (accessed February, 2024).
- García de Soto, B., Agustí-Juan, I., Joss, S., Hunhevicz, J. (2019). Implications of Construction 4.0 to the workforce and organizational structures. *International Journal of Construction Management*, 1–13. Retrieved from <https://doi.org/10.1080/15623599.2019.1616414>.
- Hall, D. M., Whyte, J. K., & Lessing, J. (2020). Mirror-breaking strategies to enable digital manufacturing in Silicon Valley construction firms: a comparative case study. *Construction management and economics*, 38(4), 322-339. <https://doi.org/10.1080/01446193.2019.1656814>
- Hunhevicz, J. J., Motie, M., & Hall, D. M. (2022). Digital building twins and blockchain for performance-based (smart) contracts. *Automation in Construction*, 133, 103981. <https://doi.org/10.1016/j.autcon.2021.103981>
- Hunhevicz, J.J., Hall, D.M., Do you need a blockchain in construction? Use case categories and decision framework for DLT design options, *Adv. Eng. Informatics*. 45 (2020) 101094. <https://doi.org/10.1016/j.aei.2020.101094>.
- Kinnaird, C., Geipel, M. (2017). Blockchain Technology: How the Inventions Behind Bitcoin are Enabling a Network of Trust for the Built Environment. Arup. Retrieved from <https://www.arup.com/perspectives/publications/research/section/blockchain-technology> (accessed February 2024).
- Klinc, R., Turk, Ž. (2019). Construction 4.0 – Digital Transformation of One of the Oldest Industries, 21, 292–410. Retrieved from <https://doi.org/10.15458/ebr.92>.
- Lasi, H., Fettke, P., Kemper, H.-G., Feld, T., Hoffmann, M., *Industry 4.0, Bus. Inf. Syst. Eng.* 6 (2014) 239–242. <https://doi.org/10.1007/s12599-014-0334-4>.
- Li, J., Kassem, M., Watson, R., A Blockchain and Smart Contract-Based Framework to Increase Traceability of Built Assets, *Proc. 37th CIB W78 Inf. Technol. Constr. Conf. (CIB W78)*. 2 (2020) 1–17.
- M.S., M., Haritha, V., M.S., S., and M., T., "Comparison on Hyperledger Fabric and Hyperledger Composer of Block Chain Technology," 2019 International Conference on Intelligent Computing and Control Systems (ICCS), Madurai, India, 2019, pp. 1299-1305, [doi: 10.1109/ICCS45141.2019.9065776](https://doi.org/10.1109/ICCS45141.2019.9065776).
- Marzouk, M., Abdelaty, A., *Monitoring thermal comfort in subways using building information modeling, Energy and Buildings*, Volume 84, 2014, Pages 252-257, ISSN 0378-7788, <https://doi.org/10.1016/j.enbuild.2014.08.006>.
- McGlenn, K., Yuce, B., Wicaksono, H., Howell, S., Rezgüi, Y., Usability evaluation of a web-based tool for supporting holistic building energy management, *Automation in Construction*, Volume 84, 2017, Pages 154-165, ISSN 0926-5805, <https://doi.org/10.1016/j.autcon.2017.08.033>.
- Panteli, C., Kylili, A., Fokaides, P.A., Building information modelling applications in smart buildings: From design to commissioning and beyond A critical review, *Journal of Cleaner Production*, Volume 265, 2020, 121766, ISSN 0959-6526, <https://doi.org/10.1016/j.jclepro.2020.121766>.
- Perera S., Nanayakkara S., Rodrigo M.N.N., Senaratne S., Weinand R., Blockchain technology: Is it hype or real in the construction industry?, *J. Ind. Inf. Integr.* 17 (2020) 100125. <https://doi.org/10.1016/j.jii.2020.100125>.
- Sawhney, A., Riley, M., Irizarry, J. (2020). *Construction 4.0*. Routledge. Retrieved from <https://doi.org/10.1201/9780429398100>.
- Tomašević, N.M., Batić, M.C., Blanes, L.M., Keane, M.M., Vraneš, S., Ontology-based facility data model for energy management, *Advanced Engineering Informatics*, Volume 29, Issue 4, 2015, Pages 971-984, ISSN 1474-0346, <https://doi.org/10.1016/j.aei.2015.09.003>
- Viryasitavat, W., Xu, L., Da Bi, Z., Sapsomboon, A., Blockchain-based business process management (BPM) framework for service composition in industry 4.0, *J. Intell. Manuf.* (2018) 1–12. <https://doi.org/10.1007/s10845-018-1422-y>.
- Watson, R., Kassem, M., Li, J. (2019). Traceability for Built Assets: Proposed Framework for a Digital Record. Retrieved from <http://nrl.northumbria.ac.uk/39912/> and <https://doi.org/10.3311/cc2019-068>
- X. (Alice) Qian, E. Papadonikolaki, Shifting trust in construction supply chains through blockchain technology, *Eng. Constr. Archit. Manag. ahead-of-p* (2020). <https://doi.org/10.1108/ECAM-12-2019-0676>.
- Ye, Z., Yin, M., Tang, L., Jiang, H. (2018). Cup-of-Water theory: A review on the interaction of BIM, IoT and blockchain during the whole building lifecycle, Pages 478-486 (2018 Proceedings of the 35th ISARC, Berlin, Germany, ISBN 978-3-00-060855-1, ISSN 2413-5844)
- Yılmaz, D., Tanyer, A.M., Toker, I.D., A data-driven energy performance gap prediction model using machine learning, *Renewable and Sustainable Energy Reviews*, Volume 181, 2023, 113318, ISSN 1364-0321, <https://doi.org/10.1016/j.rser.2023.113318>.
- Zhai Y., Chen K., Zhou J.X., Cao J., Lyu Z., Jin X., Shen G.Q.P., Lu W., Huang G.Q., An Internet of Things-enabled BIM platform for modular integrated construction: A case study in Hong Kong, *Adv. Eng. Informatics*. 42 (2019) 100997. <https://doi.org/10.1016/j.aei.2019.100997>.