

P5.0

SPONGE HOUSING

a flexible housing model for changing densities

JIANAN WANG

5117240

05/07/2021

INDEX

GENERAL INTRODUCTION

SUMMARY OF THE RESEARCH

DESIGN BRIEF

SYSTEM CONCEPT

DESIGN PROPOSAL

GENERAL INTRODUCTION

SUMMARY OF THE RESEARCH

DESIGN BRIEF

SYSTEM CONCEPT

DESIGN PROPOSAL

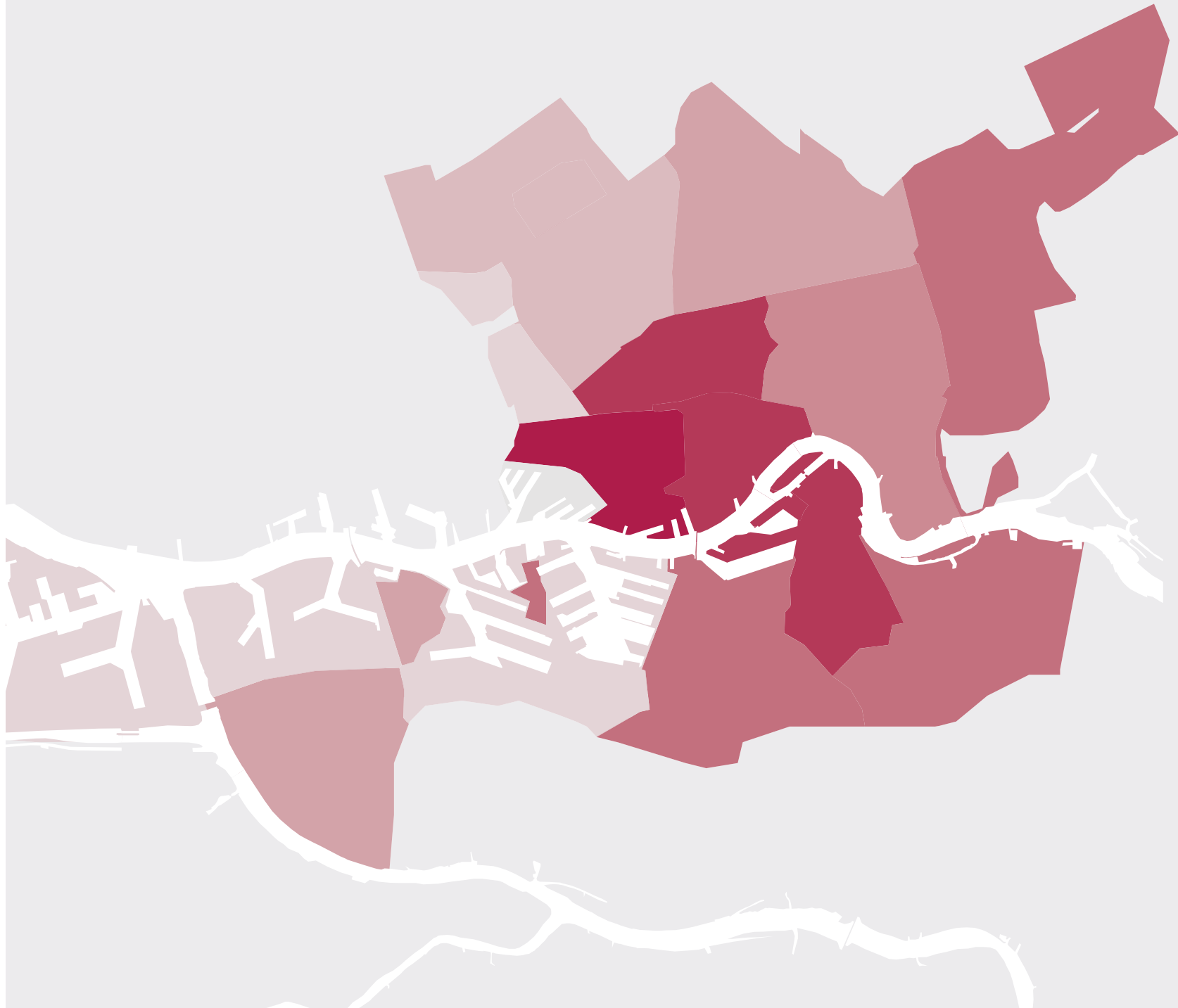

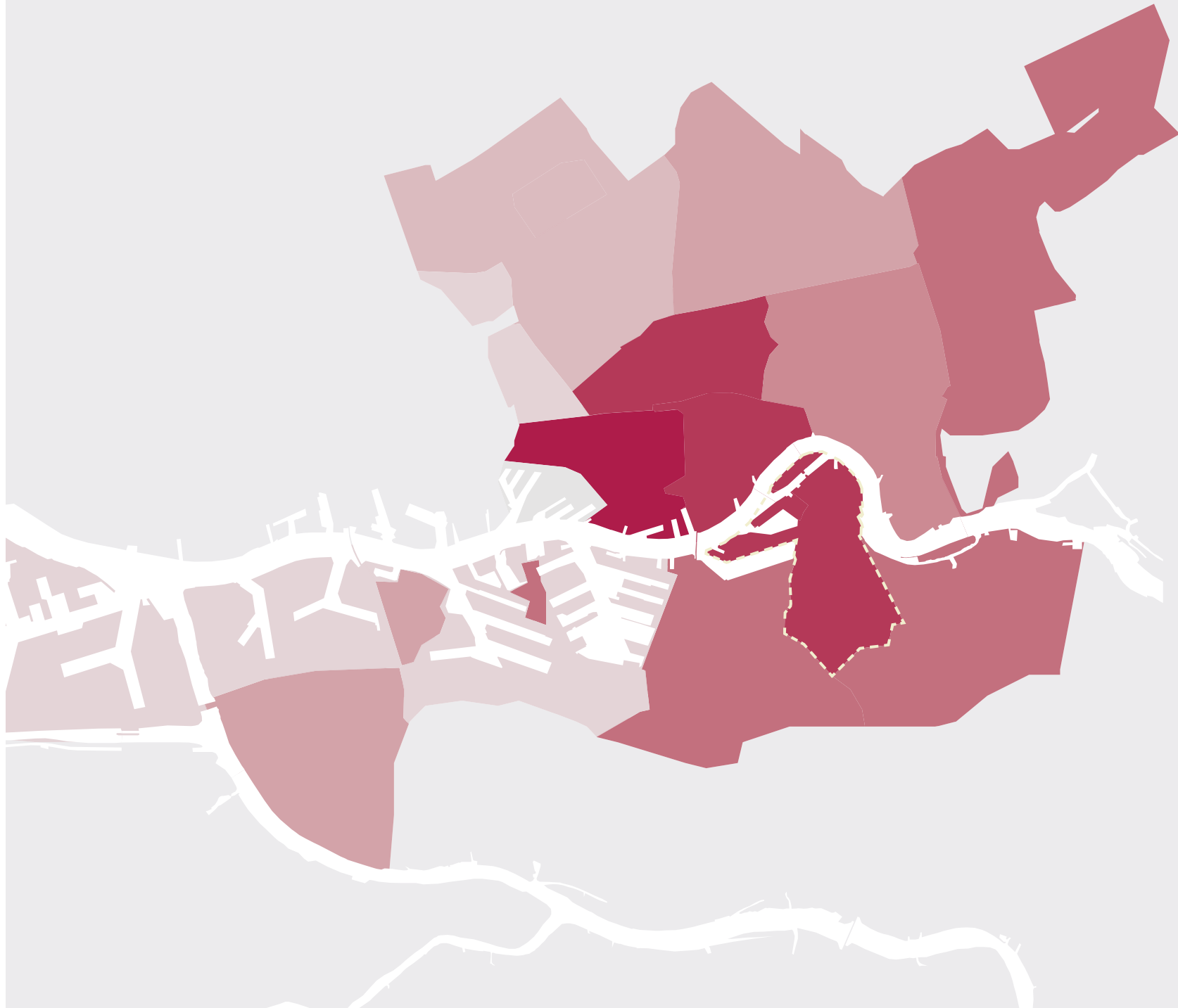

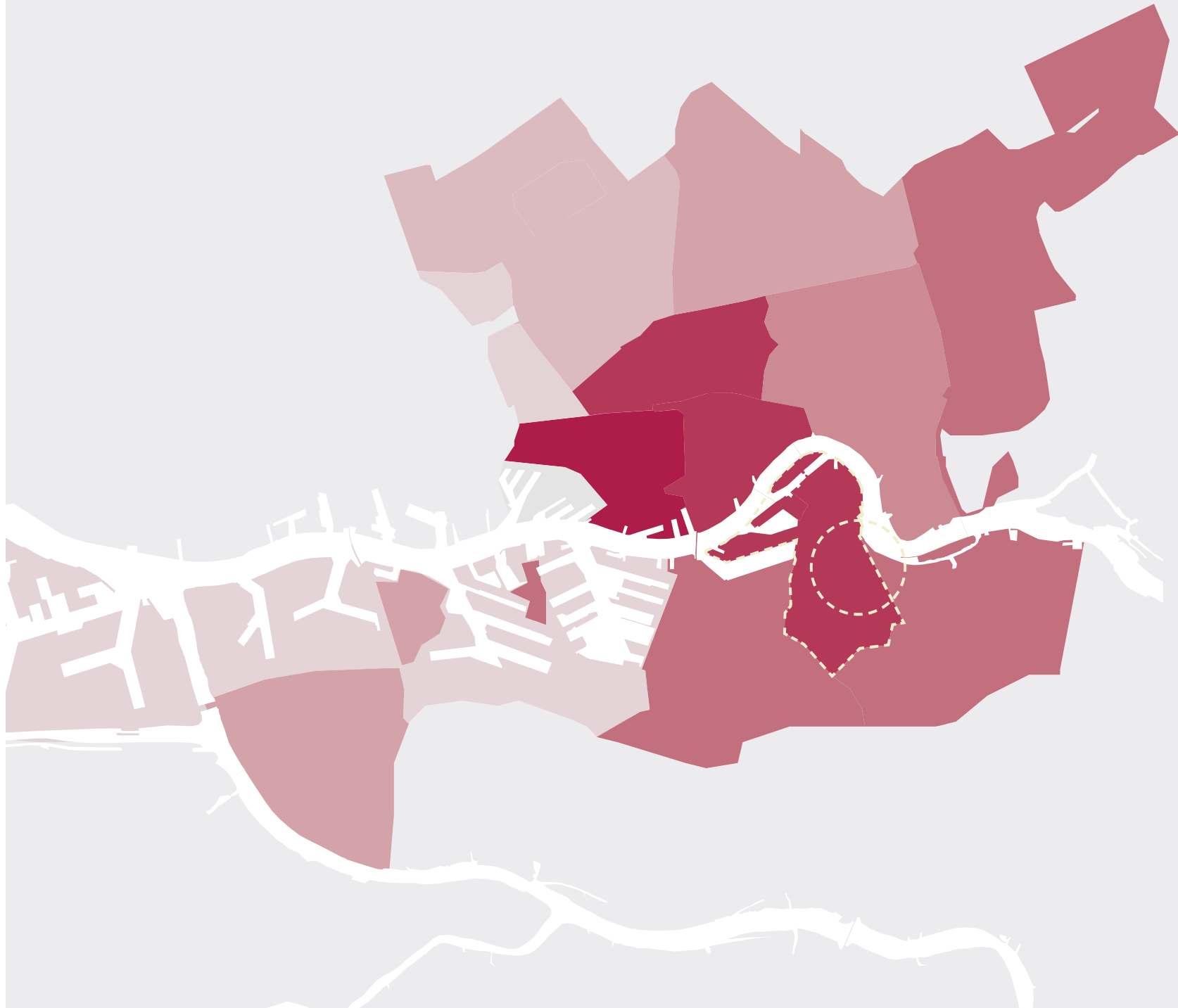

FEIJENOORD AREA



ROTTERDAM CENTRAL



AMSTERDAM CENTRAL



FEIJENOORD AREA



662

Hectare

76,590

ppl

ROTTERDAM CENTRAL



413

Hectare

36,090

ppl

AMSTERDAM CENTRAL



625

Hectare

87,310

ppl

FEIJENOORD AREA



ROTTERDAM CENTRAL

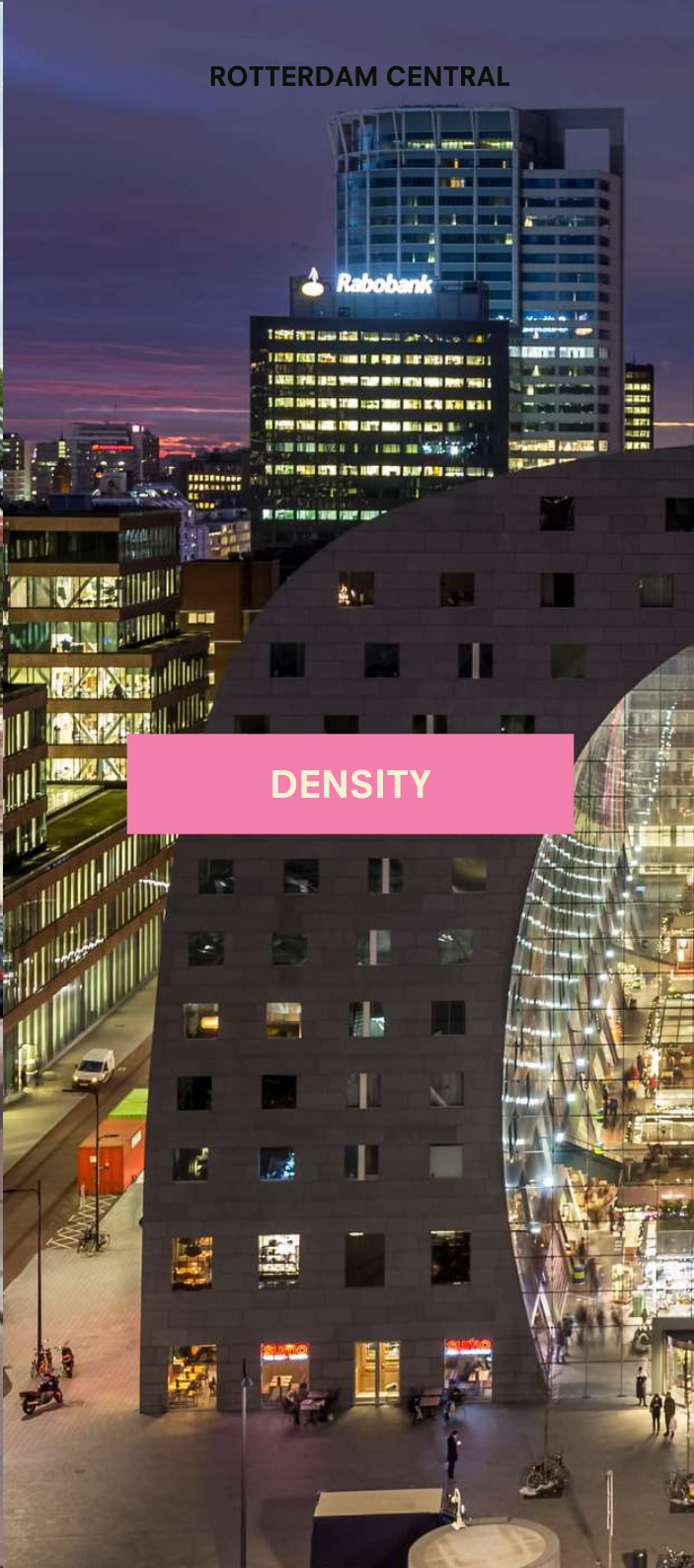

AMSTERDAM CENTRAL



DENSITY

POPULATION DENSITY

Feijenoord area



11567
PPL./KM2

54
DWELLING/HECTARE

Rotterdam Central



8732
PPL./KM2

53
DWELLING/HECTARE

Amsterdam Central

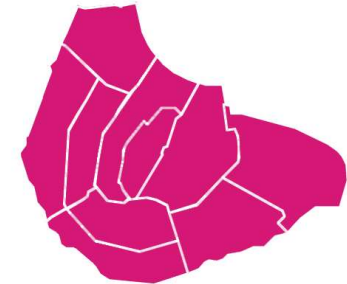

12393
PPL./KM2

74
DWELLING/HECTARE

PARADOX

**housing stock is not enough to accommodate
population in Feijenoord**

HOUSING PROBLEM

Homes with overcrowding

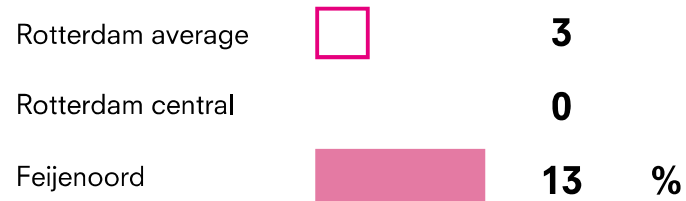

Small single-family houses

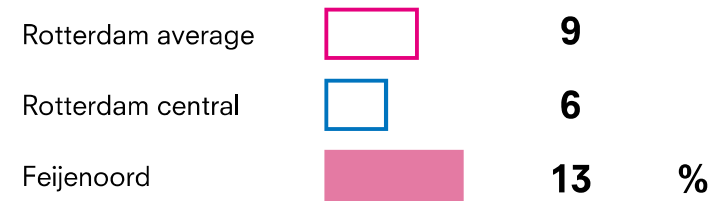

HOUSING STOCK ACCORDING TO POSSESSION

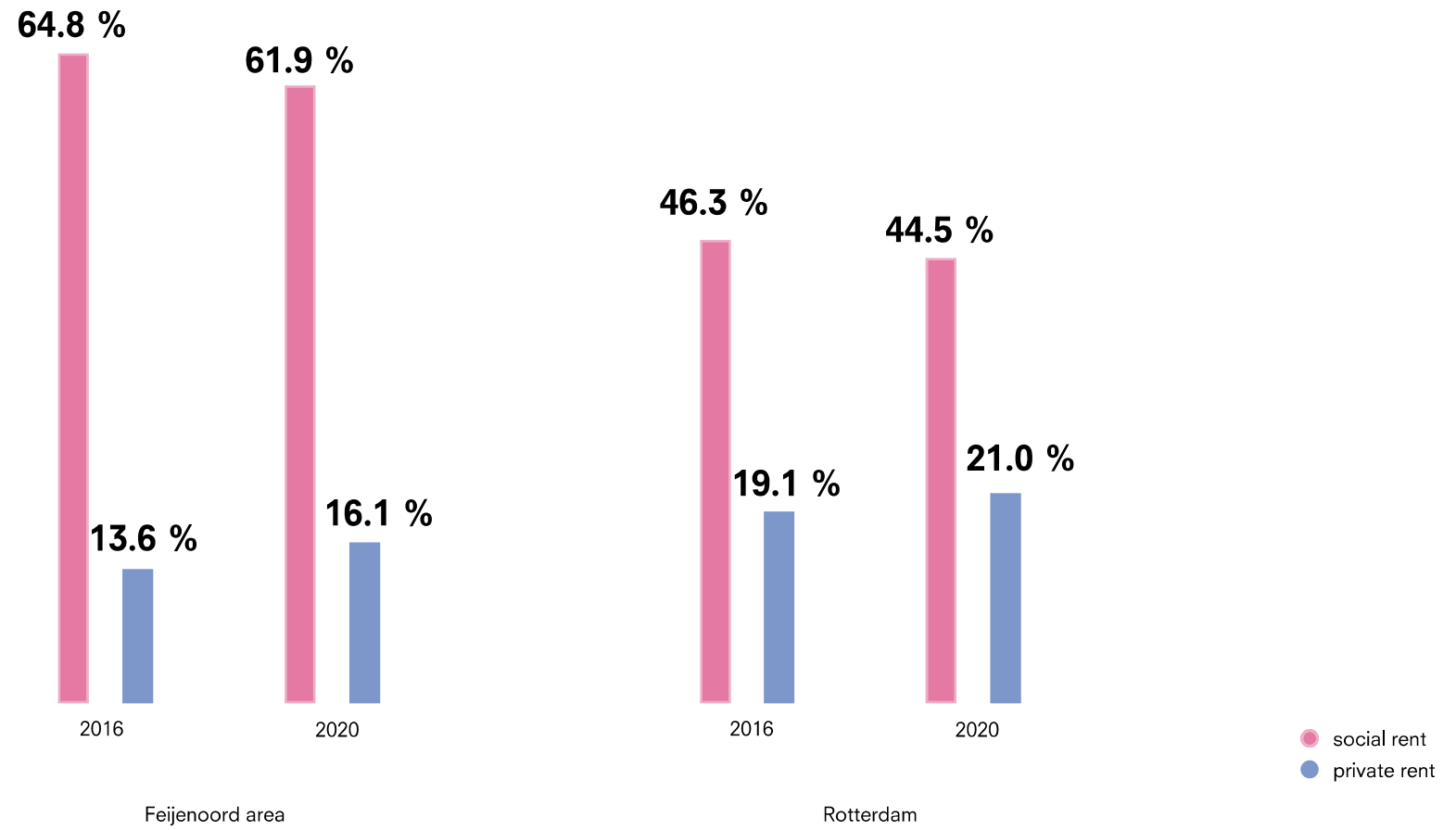

HOUSING VISION AND PLAN IN SOUTH

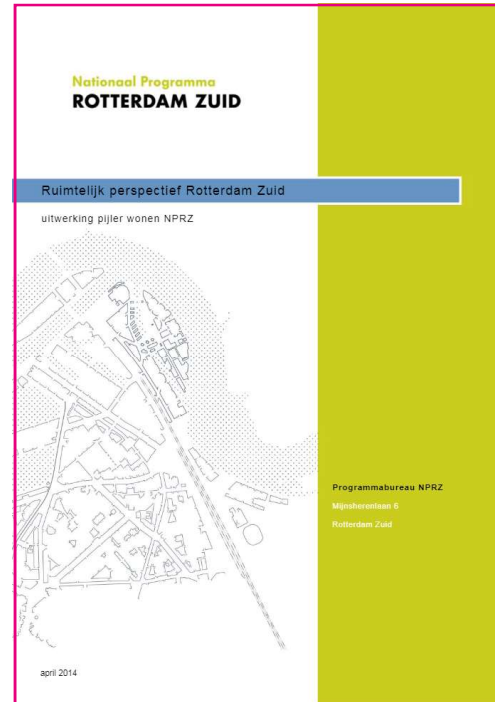

DILUTION

-2,550

current 35,915 houses in Feijenoord



merging/demolition leads to a **decrease in housing numbers**, this process is defined as **DILUTION**

NEW HOUSES IN FEIJENOORD

+5,000
current 35,915 houses in Feijenoord



DENSIFICATION is needed to **increase the number of homes** for growing population

DENSIFICATION AND DILUTION

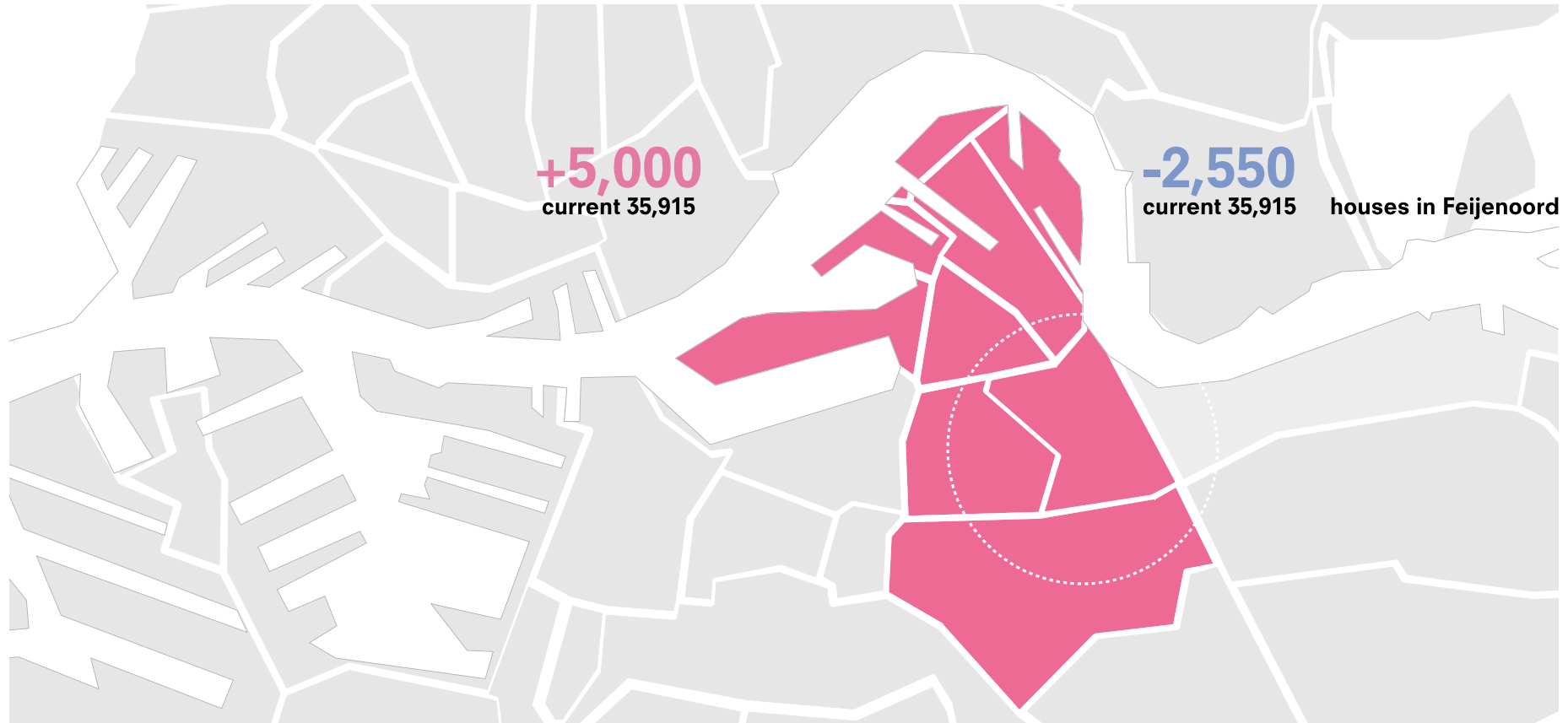

DENSIFICATION and **DILUTION** are separate processes of changing the number of houses



PROBLEM STATEMENT

A Static Housing Model

PROBLEM STATEMENT

A Static Housing Model

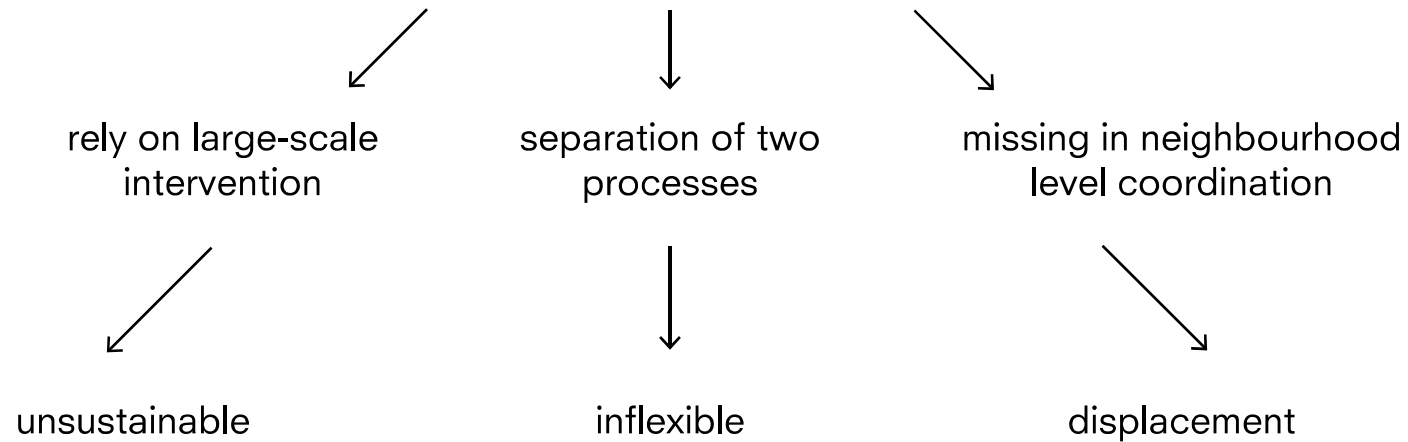



RESEARCH QUESTION

How can a **dynamic architectural model** be designed to both dilute and densify a neighbourhood, resulting in a housing system that is able to regulate its own density?



AMBITION

To create a **flexible** housing model initiated at a **neighbourhood level** that can adapt to changing residential densities through dilution and densification **at a small scale.**

GENERAL INTRODUCTION

SUMMARY OF THE RESEARCH

DESIGN BRIEF

SYSTEM CONCEPT

DESIGN PROPOSAL

HILLESLUIS

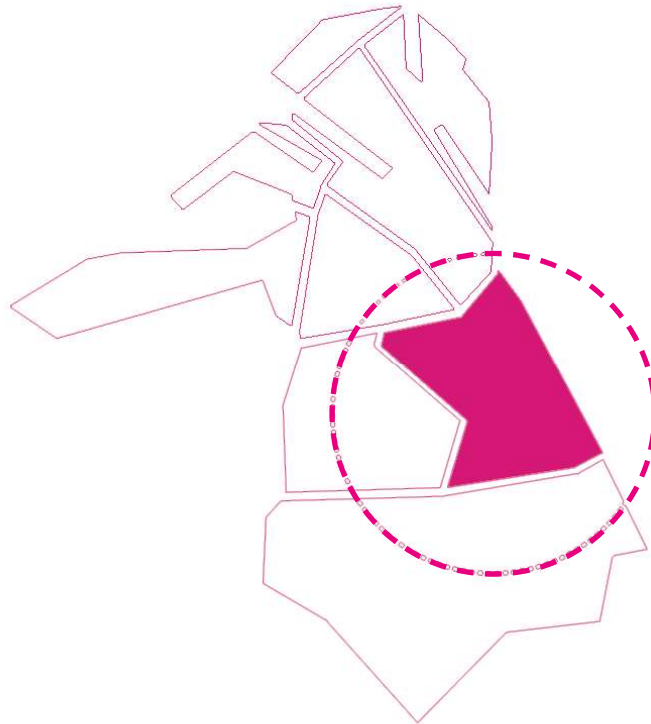

 Group site circle



71%
pre-war housing

NEIGHBOURHOOD DATA

90
Hectare

12,050
ppl

5142
houses



DESIGN FOR WIDER RANGE

+3,000
new houses



5142
current houses

PROPOSAL IN TWO SCALES

flexible housing model in Hillesluis

urban scale



more houses

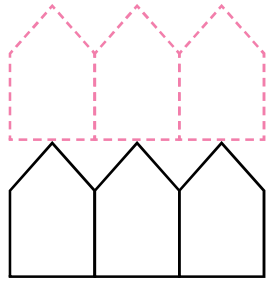

building scale



densify and dilute through flexible building

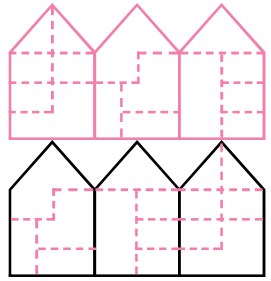

INITIAL PROJECT AMBITION



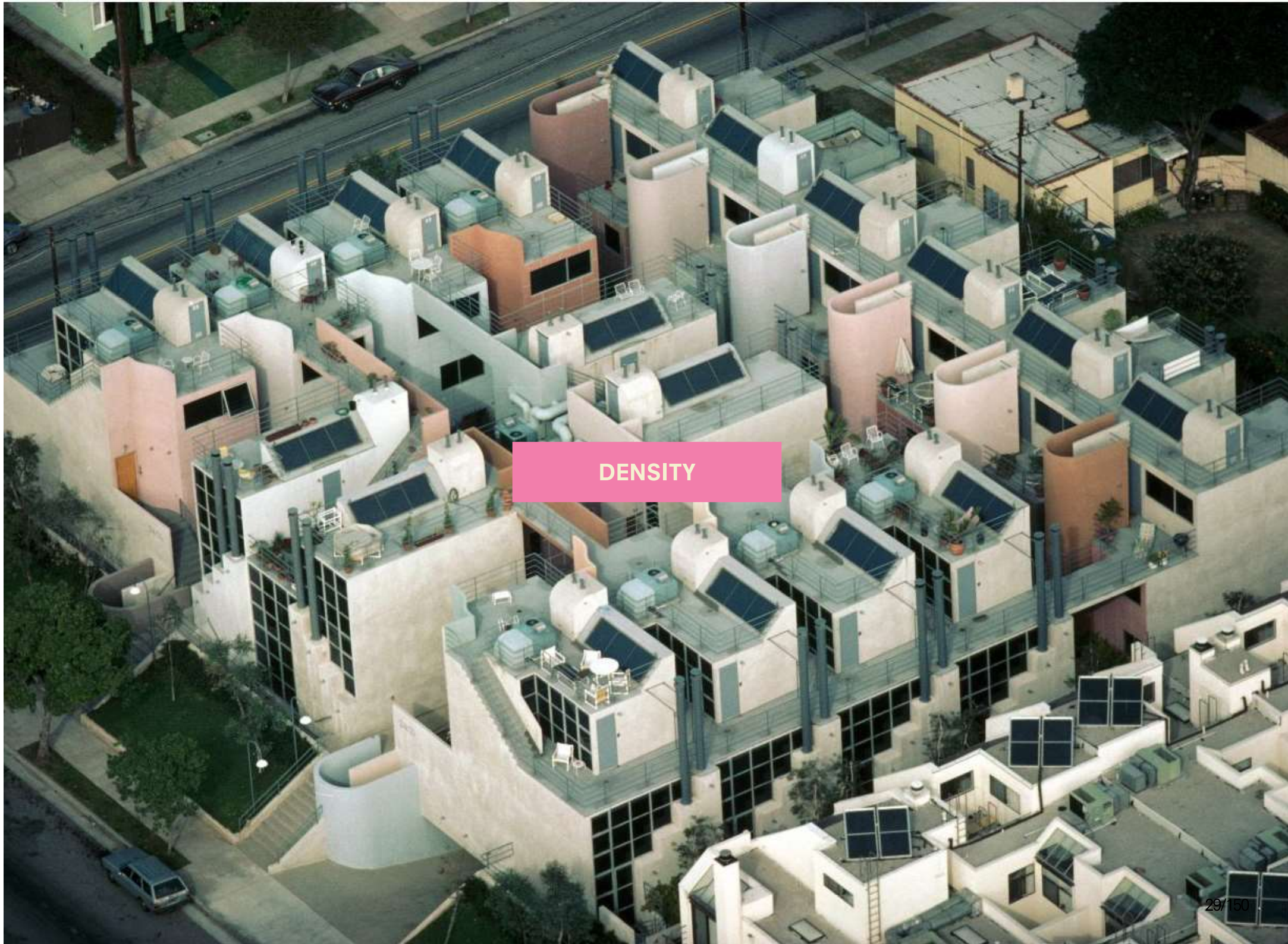

DENSITY

Summary of The Research
DENSITY AND FORM

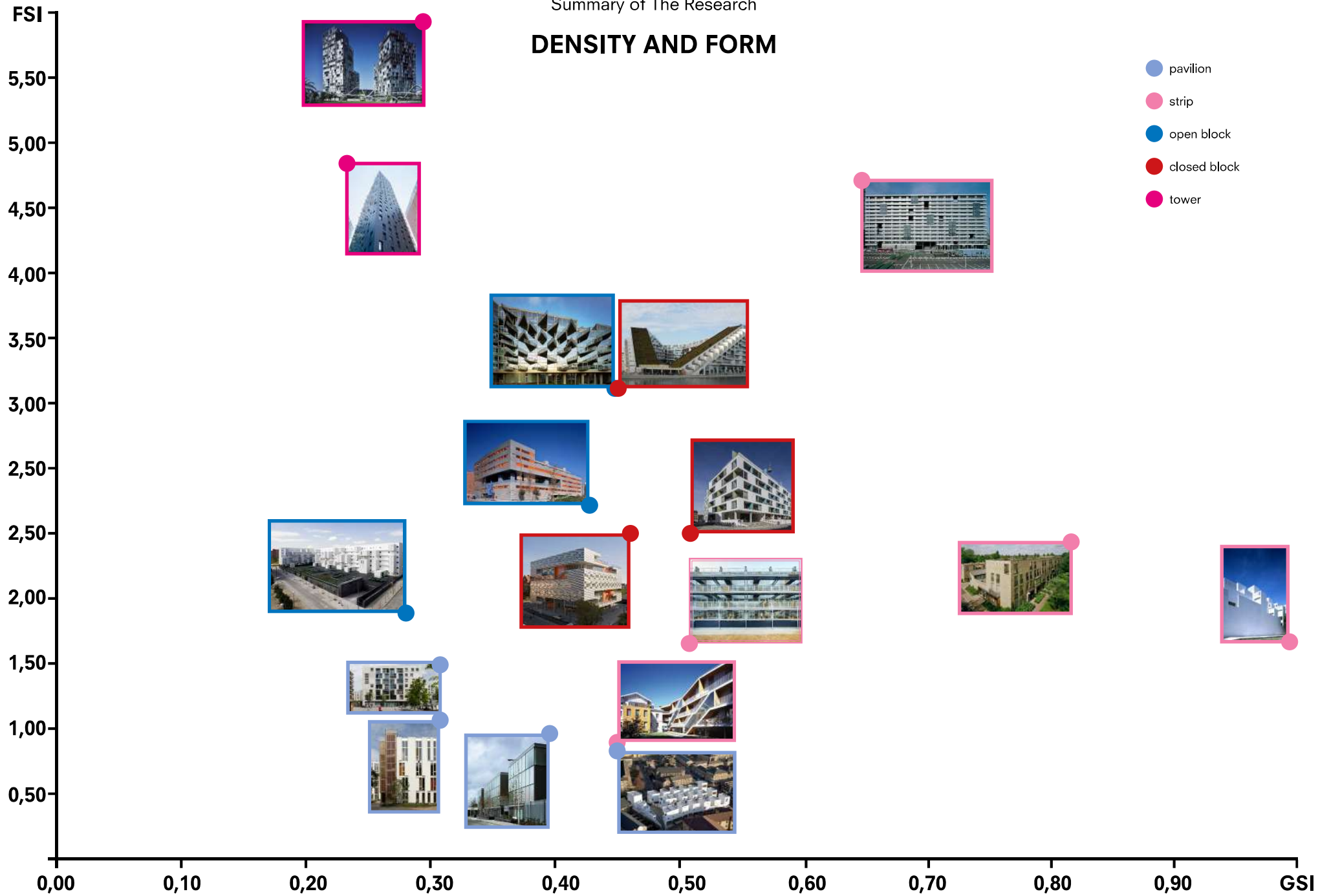

URBAN BUILDING TYPES IN HILLESLUIS



A: Low-rise compact strip



B: Mid-rise closed building blocks

Summary of The Research
DENSITY AND FORM

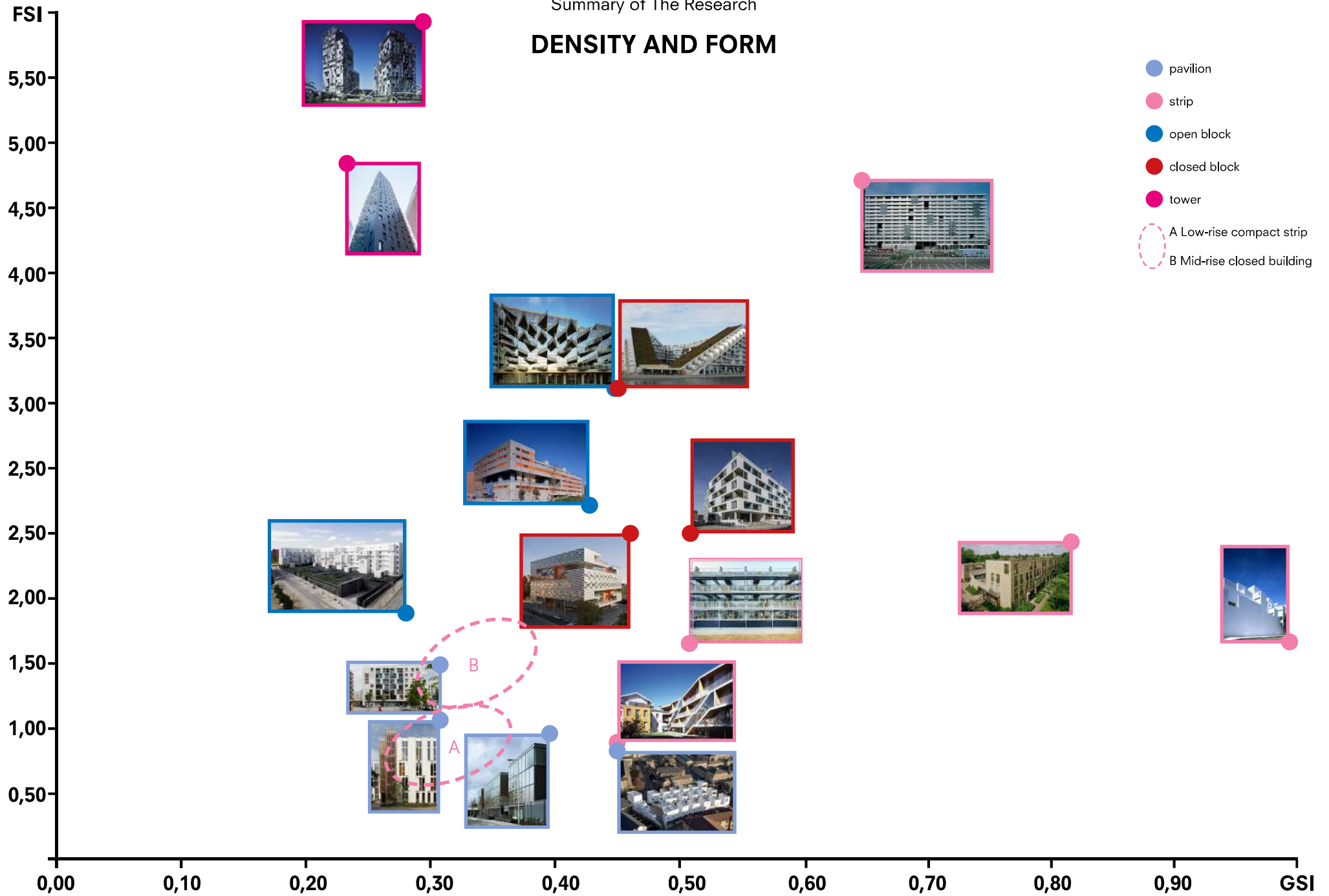

DENSIFY STRATEGY

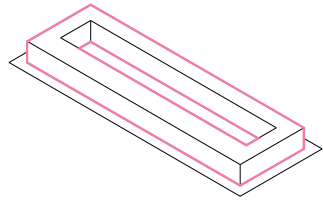

Low-rise compact strip

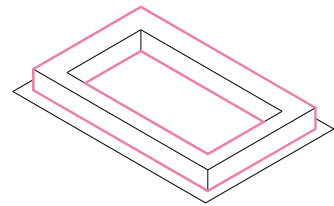
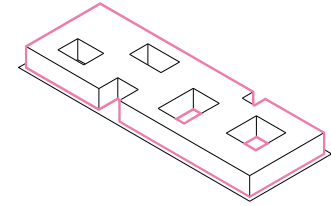
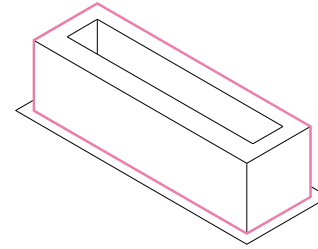
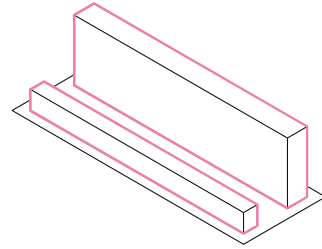

Mid-rise closed building blocks

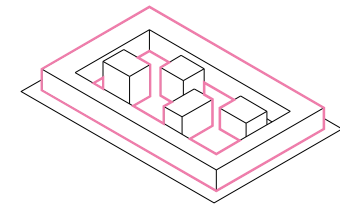
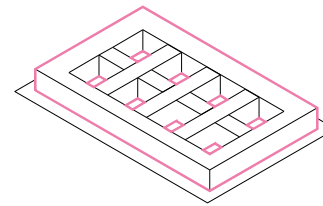
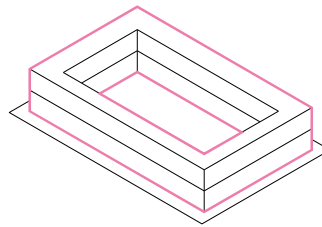

URBAN AMBITION

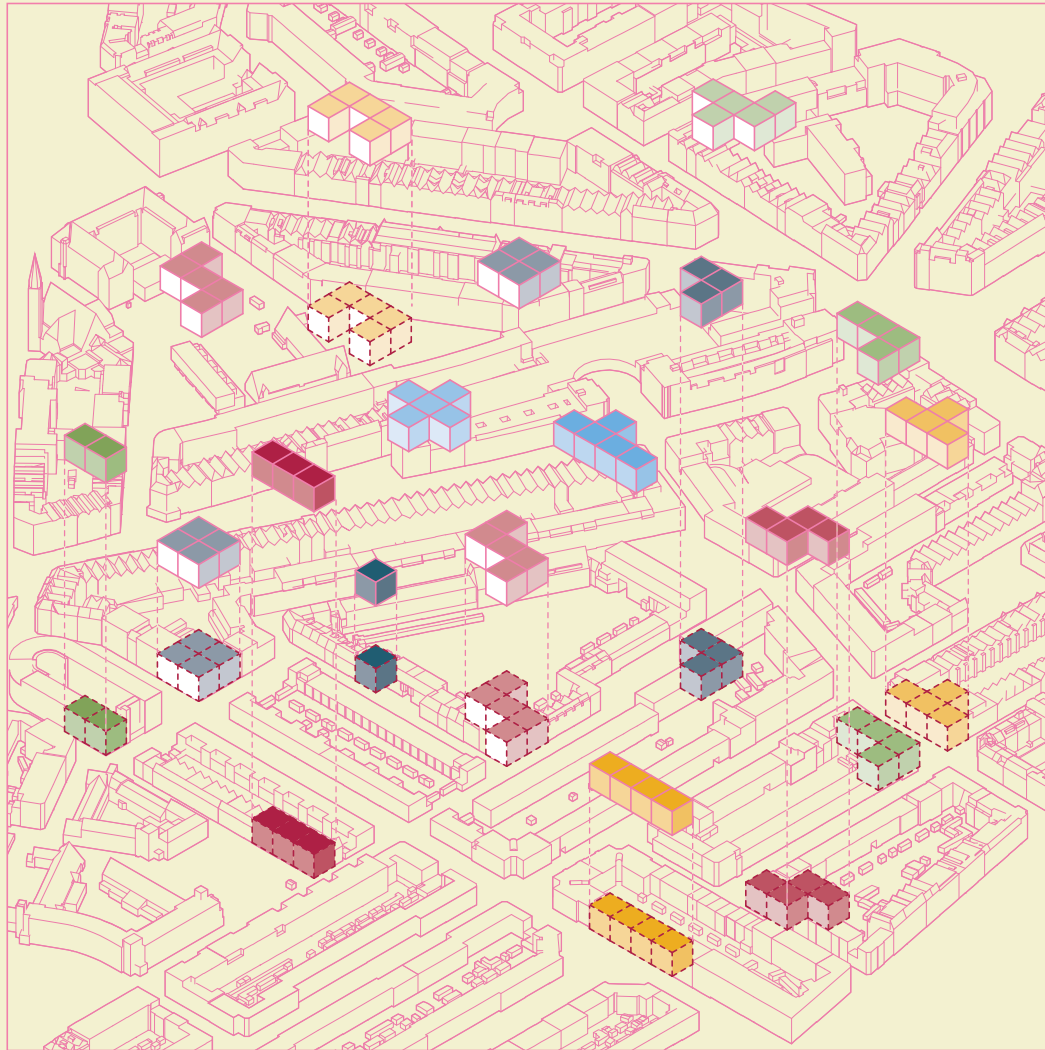

GENERAL INTRODUCTION

SUMMARY OF THE RESEARCH

DESIGN BRIEF

SYSTEM CONCEPT

DESIGN PROPOSAL

GENERAL INTRODUCTION

SUMMARY OF THE RESEARCH

DESIGN BRIEF

site/program

SYSTEM CONCEPT

DESIGN PROPOSAL

SITE LOCATION



An aerial photograph of a city grid. A white rectangular box highlights a specific site location in the center of the grid. To the right of the highlighted site, there is a large, open area with trees and a building, labeled as an adjacent park. The city grid consists of numerous rectangular blocks with streets and buildings. A large, multi-lane road or highway runs diagonally across the right side of the image. The overall scene is a dense urban environment with a mix of residential and commercial buildings.

SITE LOCATION

adjacent park

SITE LAYERS



- residential
- community
- healthcare
- cultural landmarks
- religious
- education
- offices
- commercial/retail

SITE LAYERS



new metro line proposed by the group vision

new metro line proposed by the government

- - - access to public transportation
- metro line
- bus line
- tram line
- site

SITE QUALITIES



CONTRIBUTE TO GROUP STRATEGY

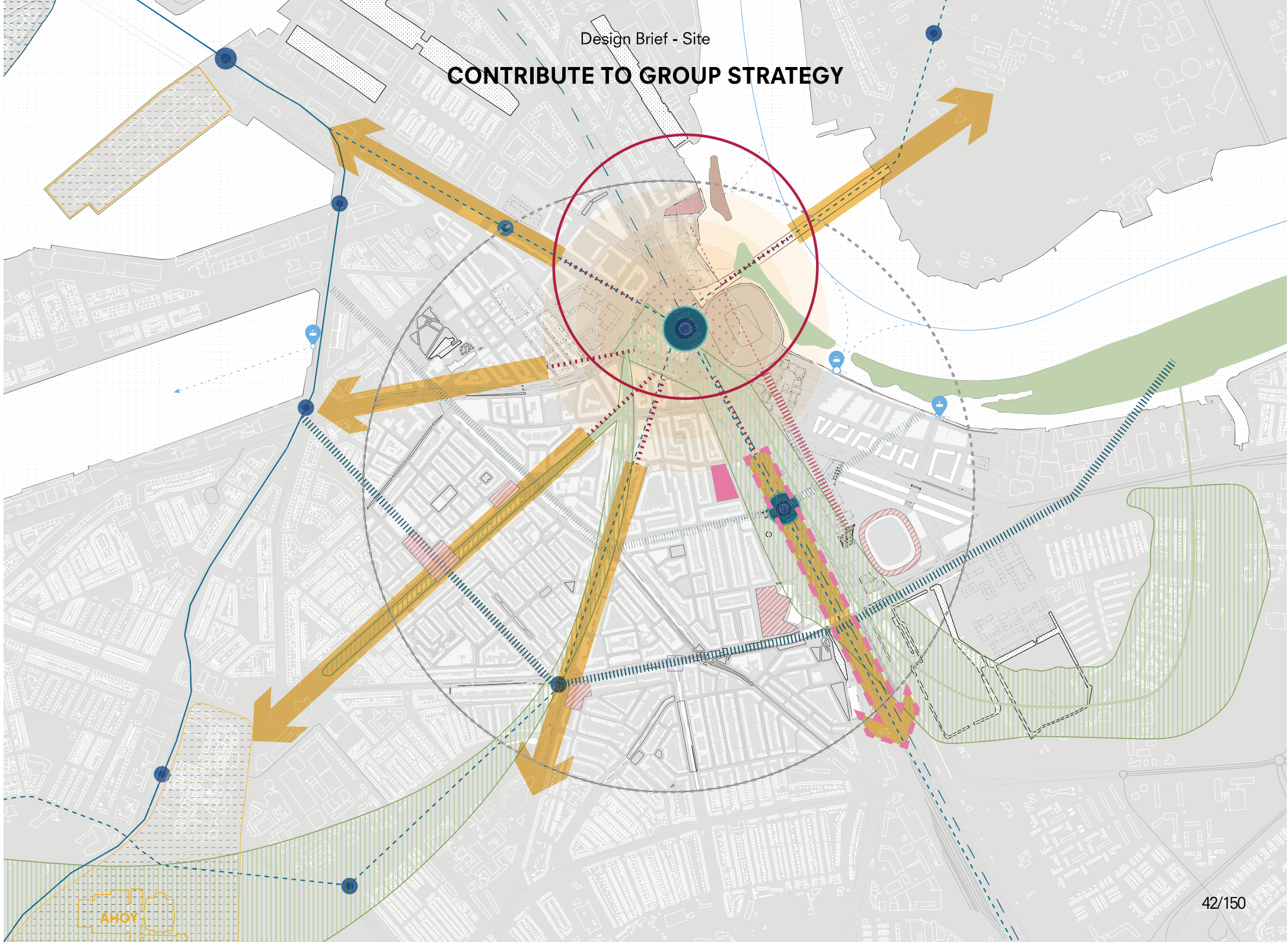

AHOY

SITE AREA

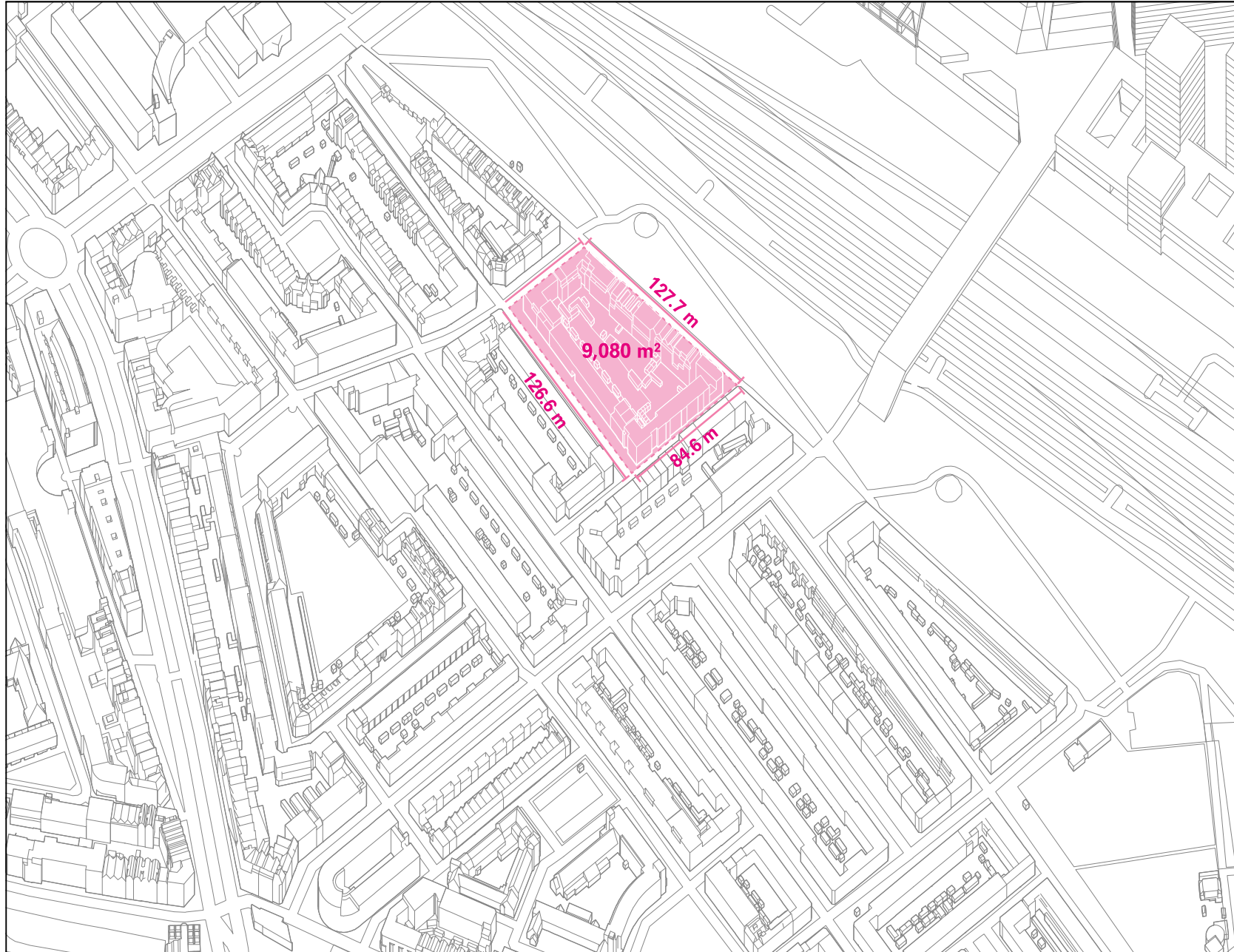

OPTIMAL DENSITY

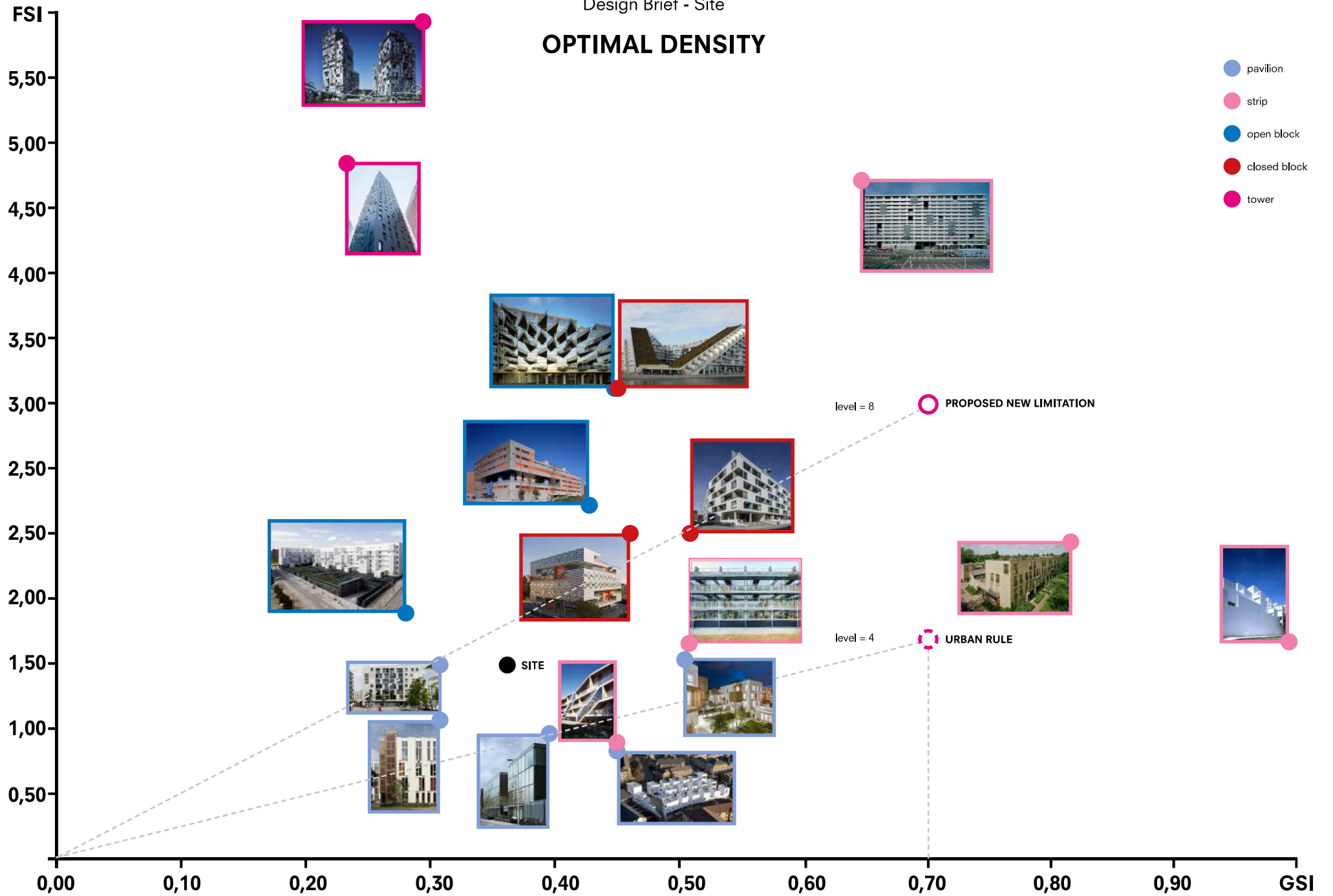

MASSING STUDY

Build on an empty lot

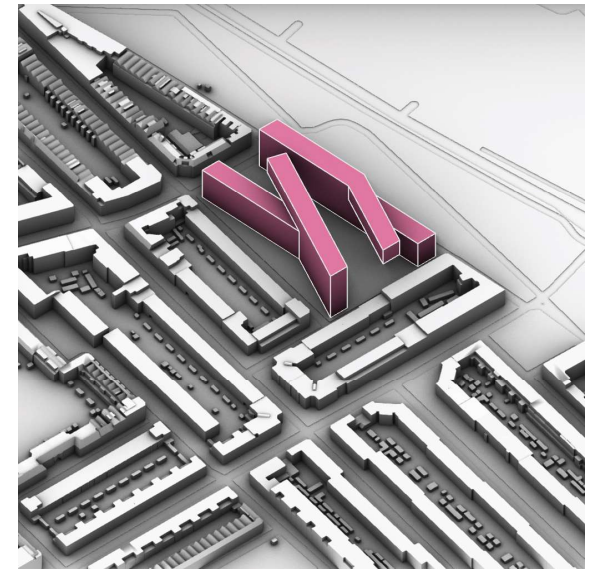
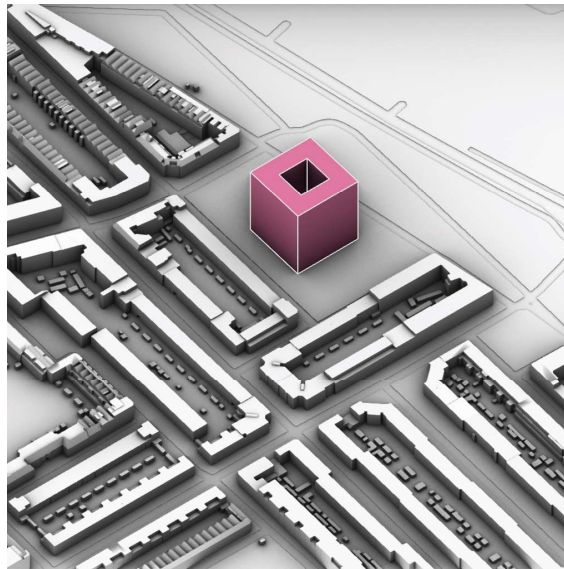
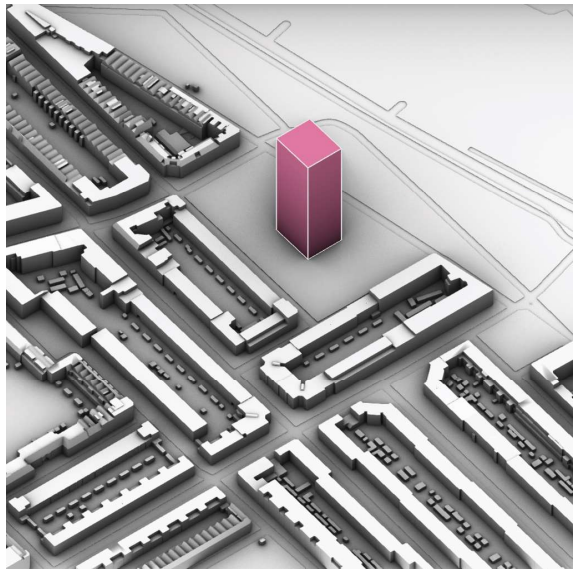
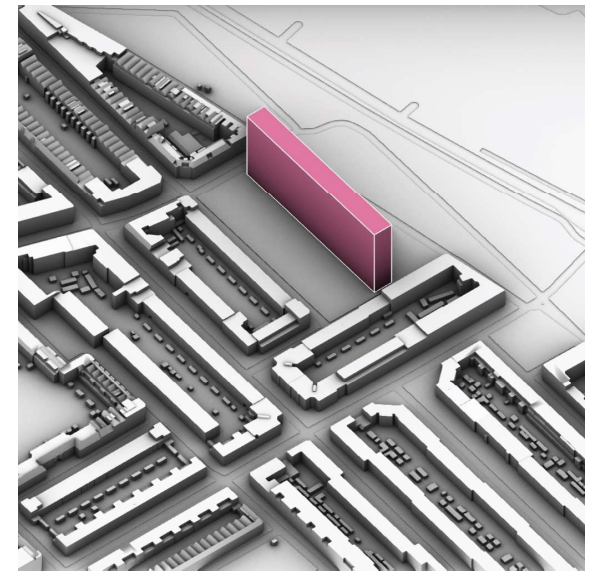
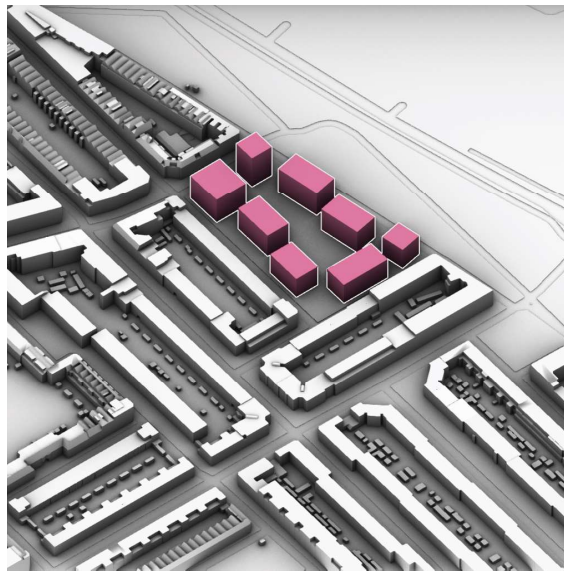
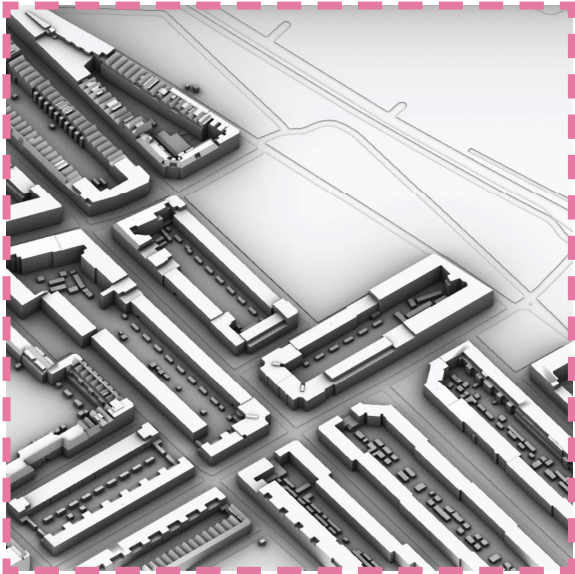

GENERAL INTRODUCTION

SUMMARY OF THE RESEARCH

DESIGN BRIEF

site/program

SYSTEM CONCEPT

DESIGN PROPOSAL

DESIGN FOR WIDER RANGE

+3,000
new houses



5142
current houses

BUILDING BLOCK ON SITE

~60
new houses

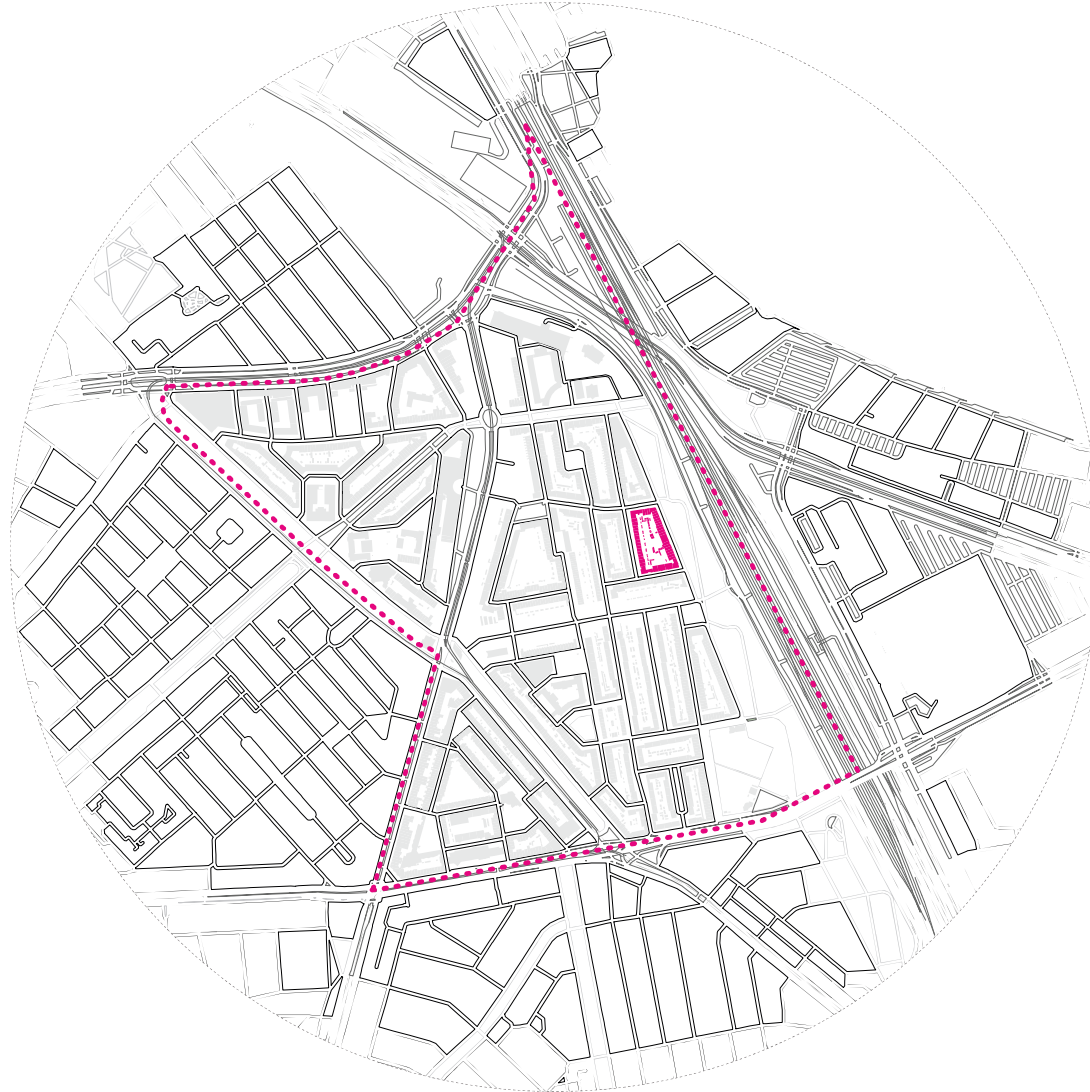

BENCHMARK



Location: Denmark
 Architect: C.F. Moller
 Plot area: 4,397 m2
 Floor area: 11,000 m2
 Dwelling: 102

Density: 232 dw/ha

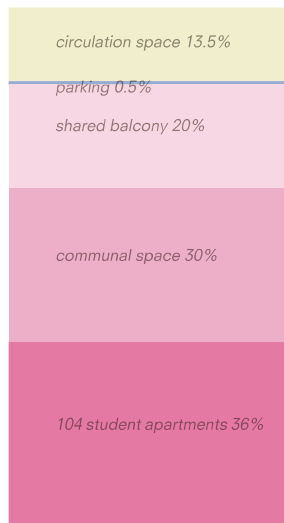

Location: Denmark
 Architect: AART
 Plot area: 2,495 m2
 Floor area: 6,950 m2
 Dwelling: 107

Density: 429 dw/ha

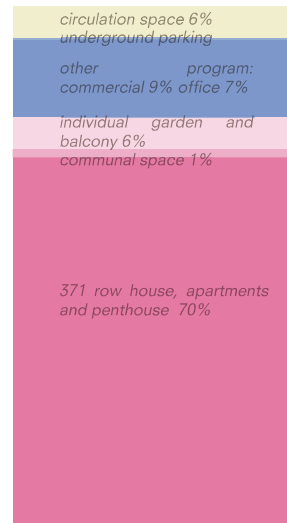

Location: Denmark
 Architect: BIG
 Plot area: 18,299 m2
 Floor area: 61,000 m2
 Dwelling: 471

Density: 257 dw/ha



Location: Hillesluis, Rotterdam
 Plot area: 9,080 m2
 Floor area: 3,274 m2
 Dwelling: 112

Density: 123 dw/ha

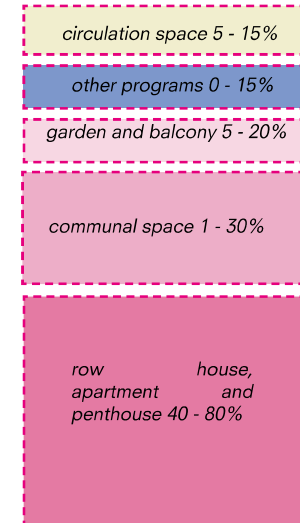

Sponge housing
 Plot area: 9,080 m2
 Floor area: 25,000 m2
 Dwelling: 112 - 172

Density: ~ dw/ha

PROGRAMS

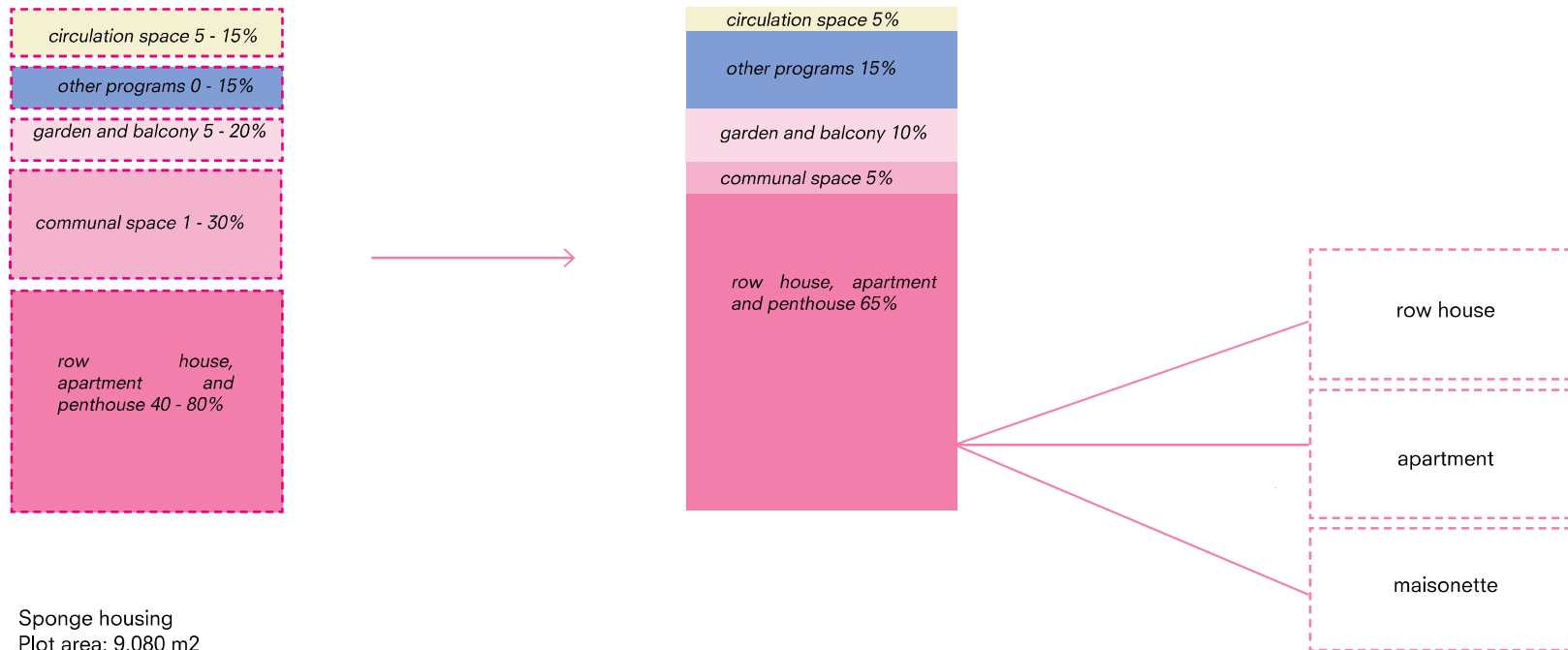

Sponge housing
Plot area: 9,080 m²
Floor area: 25,000 m²
Dwelling: 112 - 172

Density: ~ dw/ha

INTRODUCTION

SUMMARY OF THE RESEARCH

DESIGN BRIEF

SYSTEM CONCEPT

DESIGN PROPOSAL

DESIGN QUESTIONS

- 1. What is flexible and what is permanent?
flexible programs (housing, public program), permanent structure**
- 2. How the houses can be added?**
- 3. How the extra space created for flexibility can be used?**

CONCEPTUAL MASSING STUDY

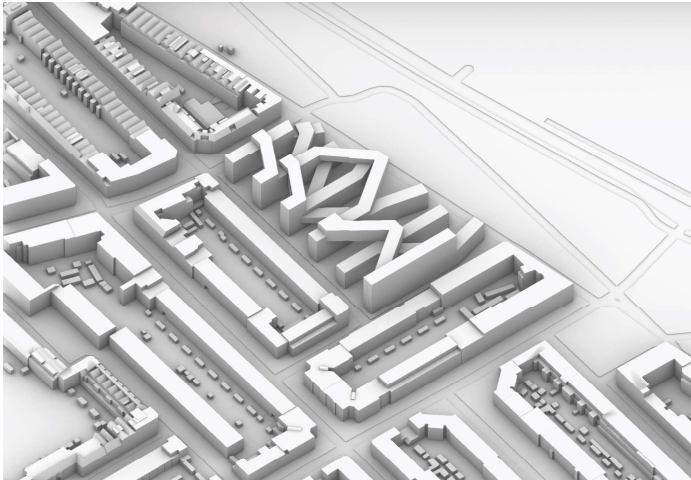

1. house grow in two sides

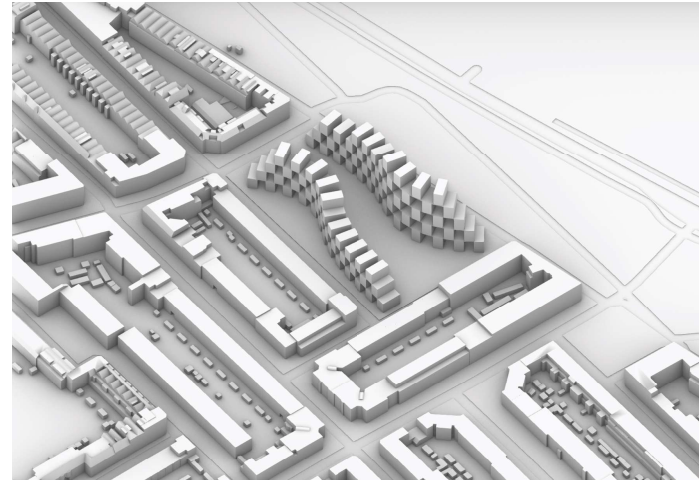

2. modular houses stack on top and insert in between



3. add houses in pre-defined infrastructure



4. add houses under the platform

CONCEPTUAL MASSING



CONCEPT - UP TO DOWN

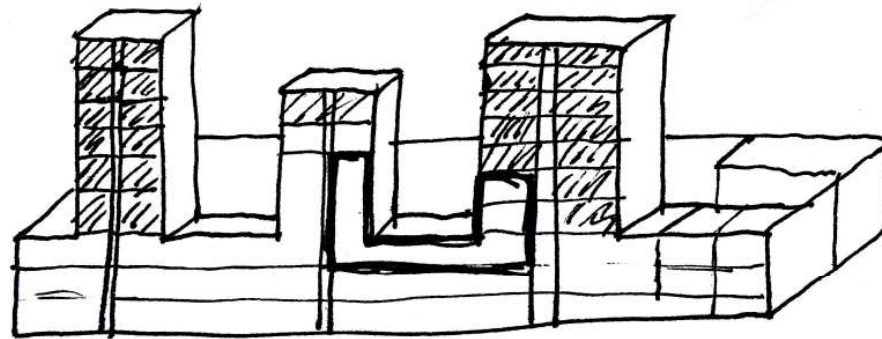

SYSTEM FOR DILUTION AND DENSIFICATION

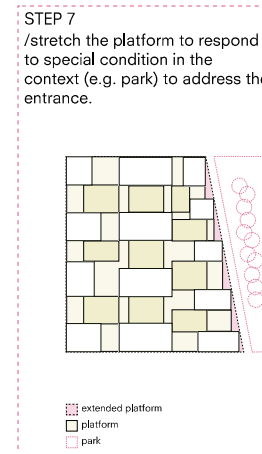
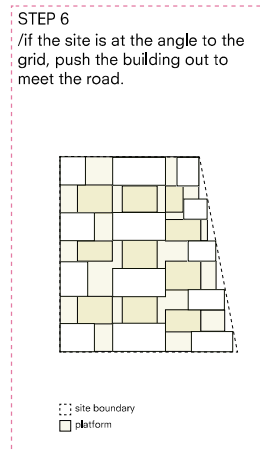
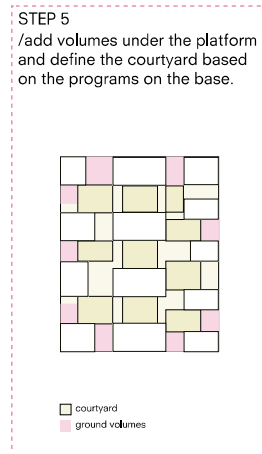
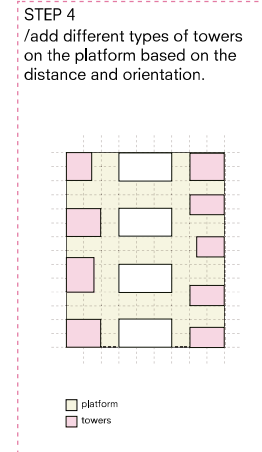
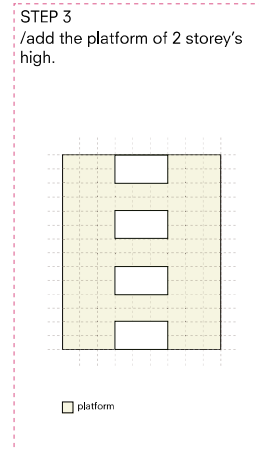
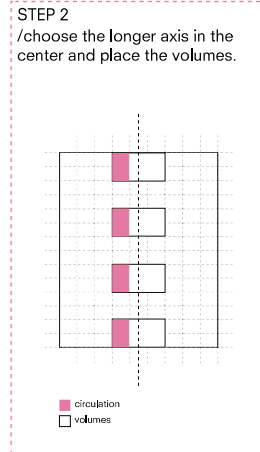
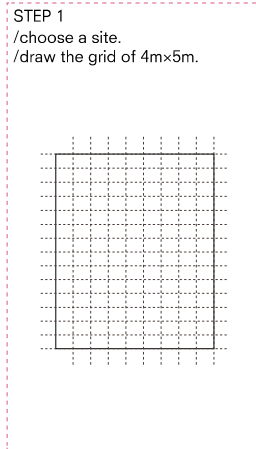

GRID ON SITE

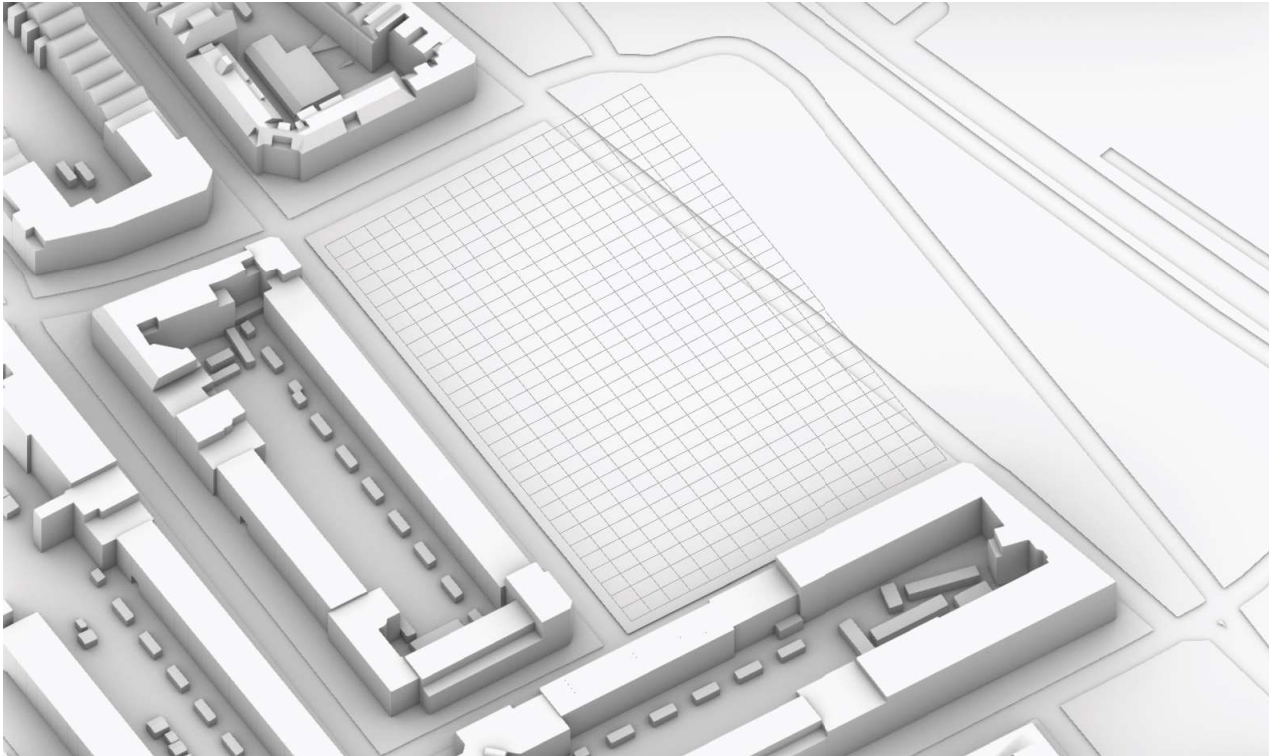

STEP 1

/choose a site.
/draw the grid of 4m×5m. (it is considered as the most appropriate structural grid size for housing)

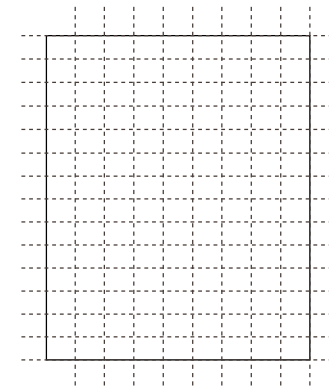

CENTRAL SPINE

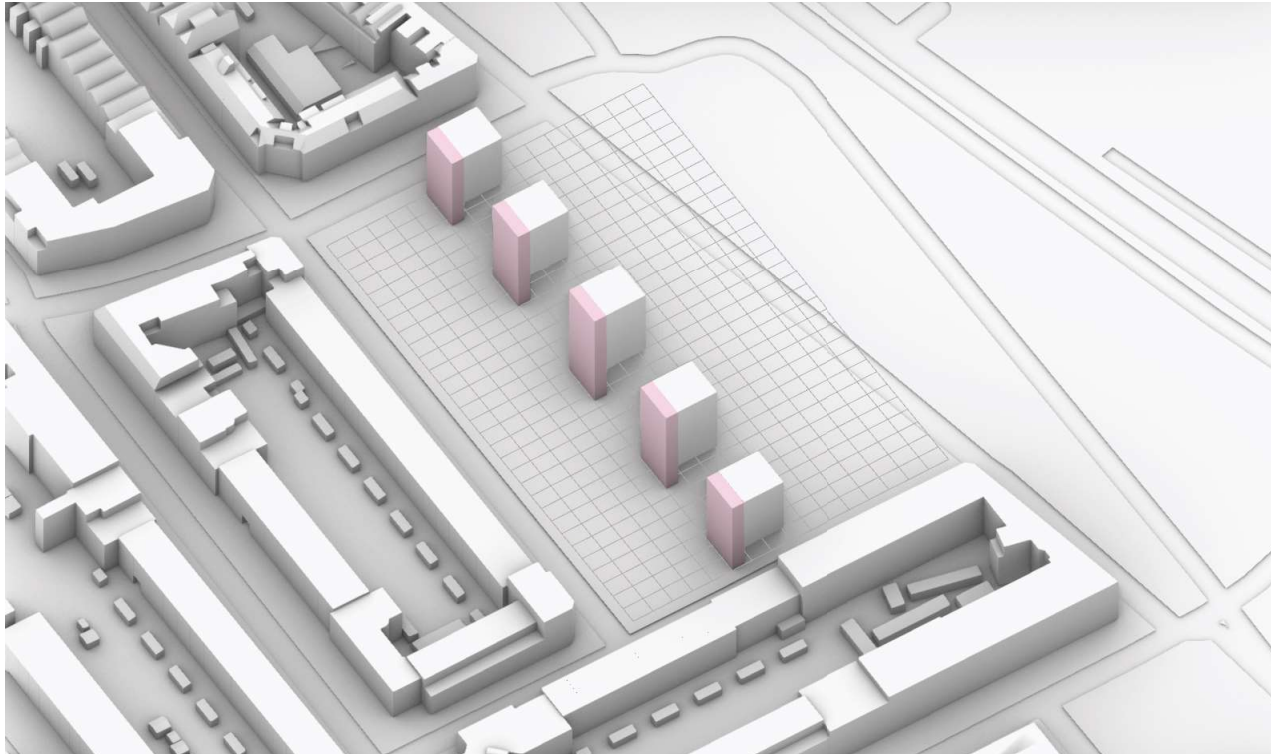

STEP 2
/choose the longer axis in the center and place the volumes.

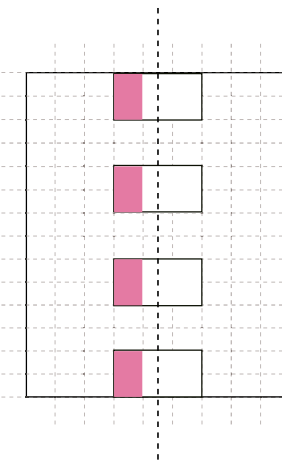

■ circulation
□ volumes

SECOND FLOOR PLATFORM

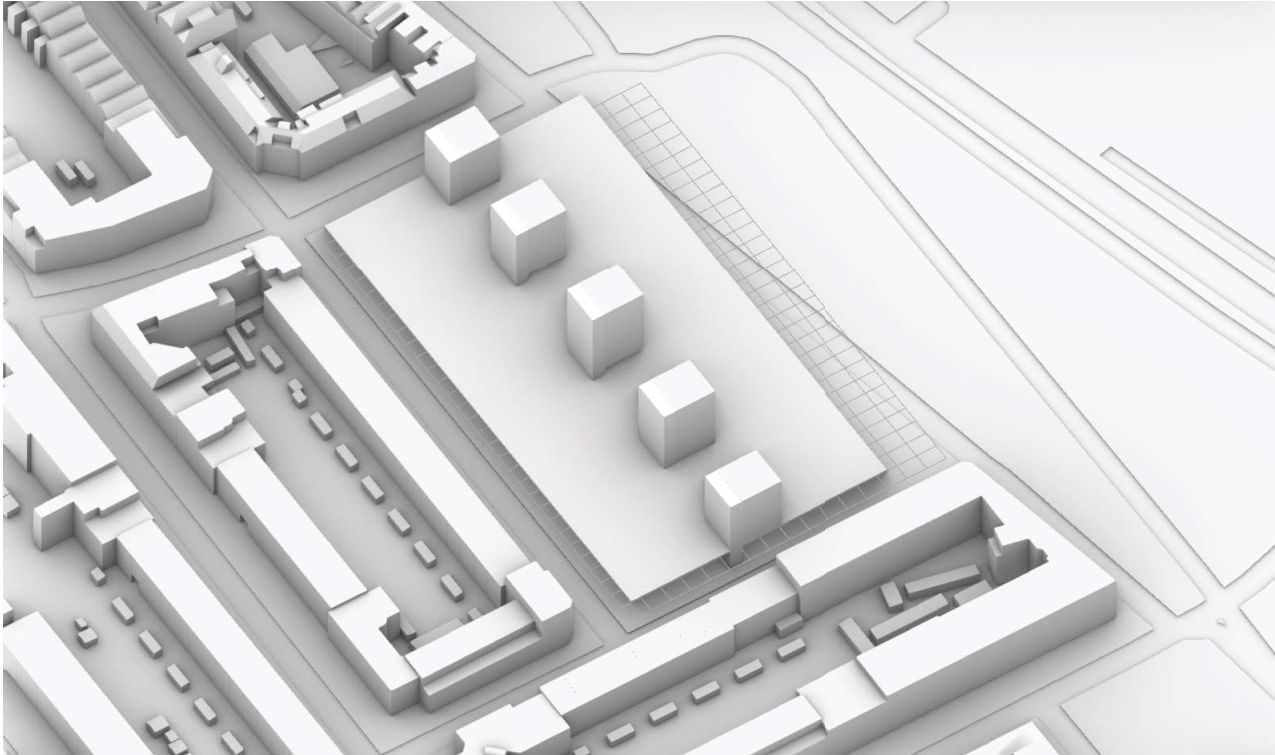

STEP 3
/add the platform of 2 storey's high.

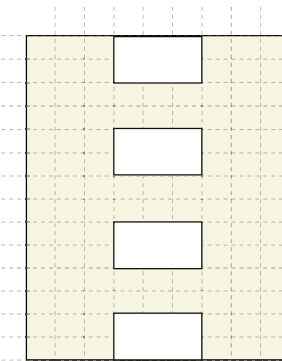

□ platform

ADD TOWERS



STEP 4
/add different types of towers
on the platform based on the
distance and orientation.

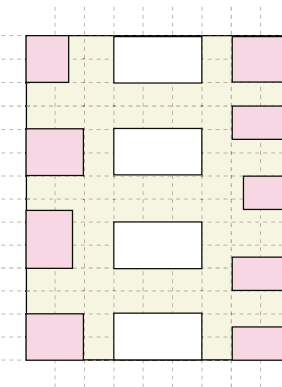

platform
towers

DEFINE COURTYARDS & PERMEABLE GROUND

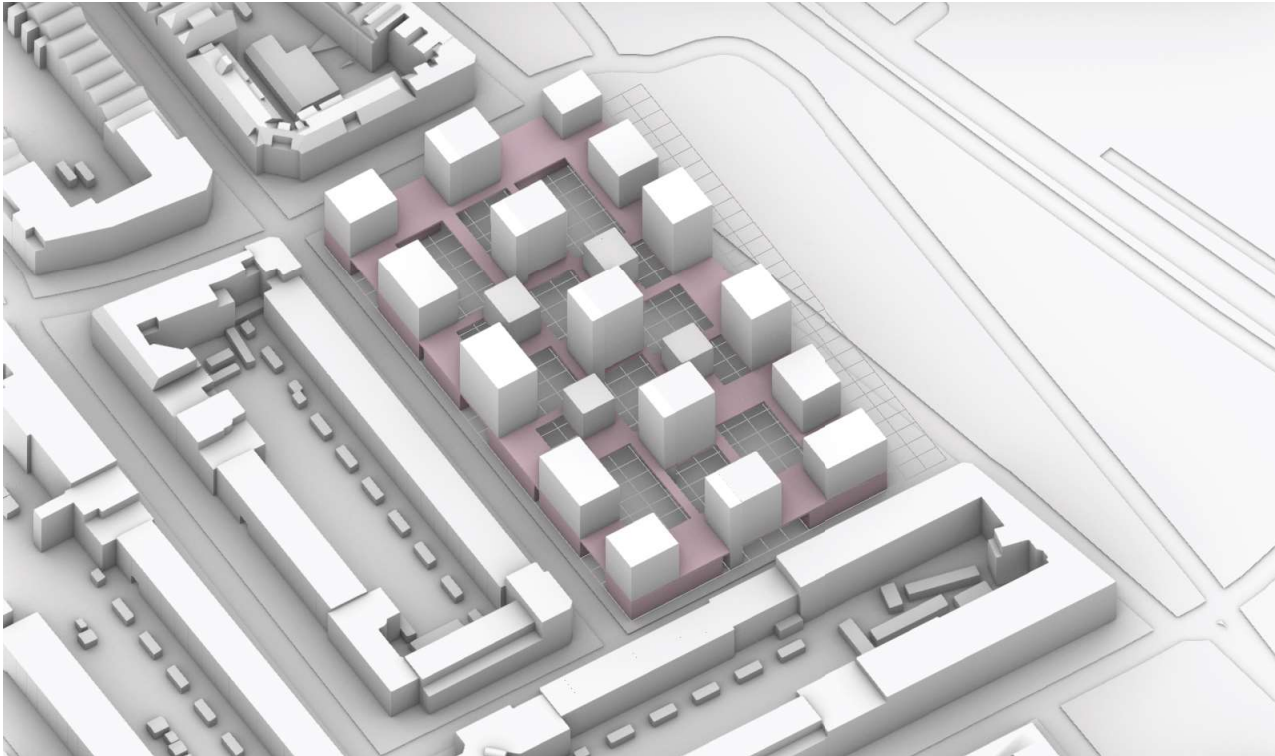

STEP 5
/add volumes under the platform
and define the courtyard based
on the programs on the base.

A floor plan diagram showing a grid of building footprints and courtyards. The courtyards are shaded in light yellow-green, and the ground volumes are shaded in light pink. The diagram is enclosed in a dashed red border.

Legend:
□ courtyard
□ ground volumes

MOVE ALONG THE BOUNDARY



STEP 6

/if the site is at the angle to the grid, push the building out to meet the road.

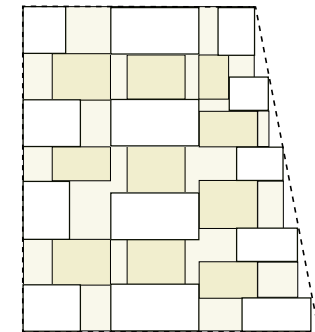

--- site boundary
□ platform

CORNER CONDITION POSSIBILITIES

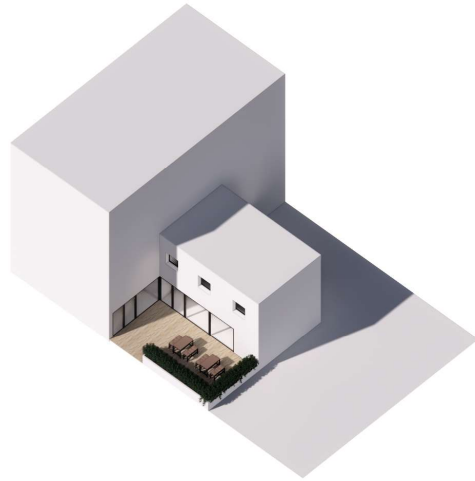

corner entrance

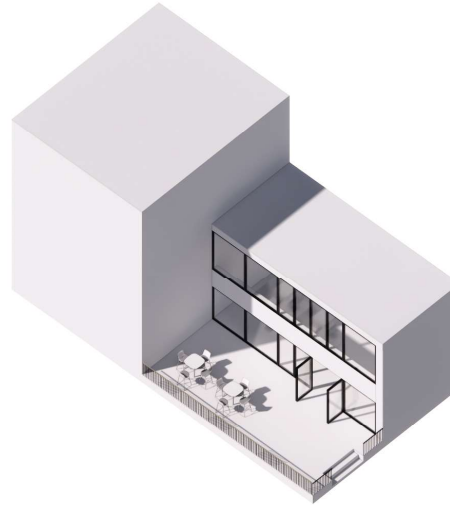

elevated platform

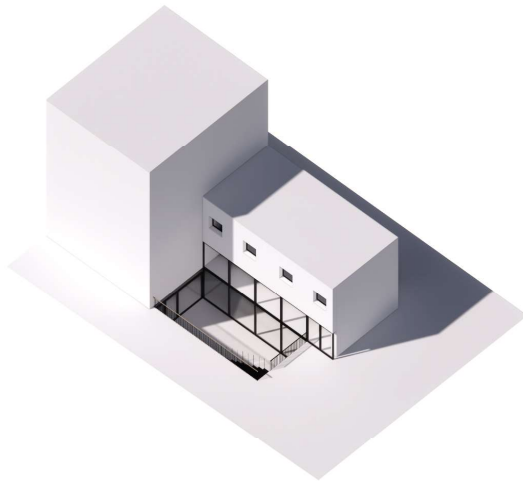

corner sunken

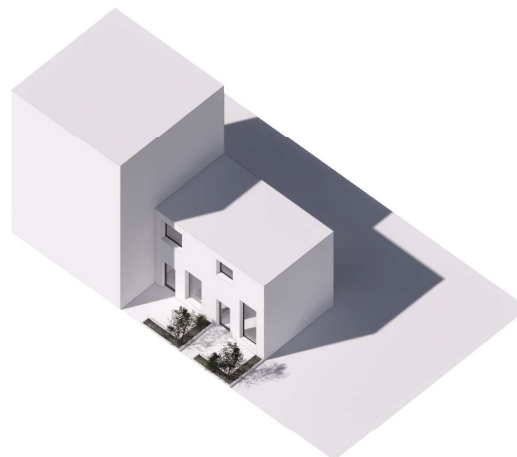

corner garden

STEP 6

/if the site is at the angle to the grid, push the building out to meet the road.

/corners can function in different ways depending on the program and context.

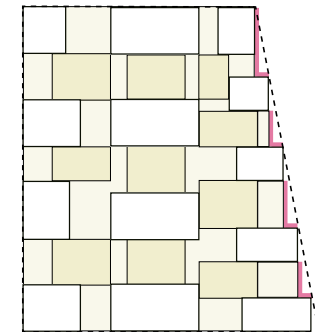

--- site boundary

— corner edge

EXTENDED PLATFORM AS CANOPY

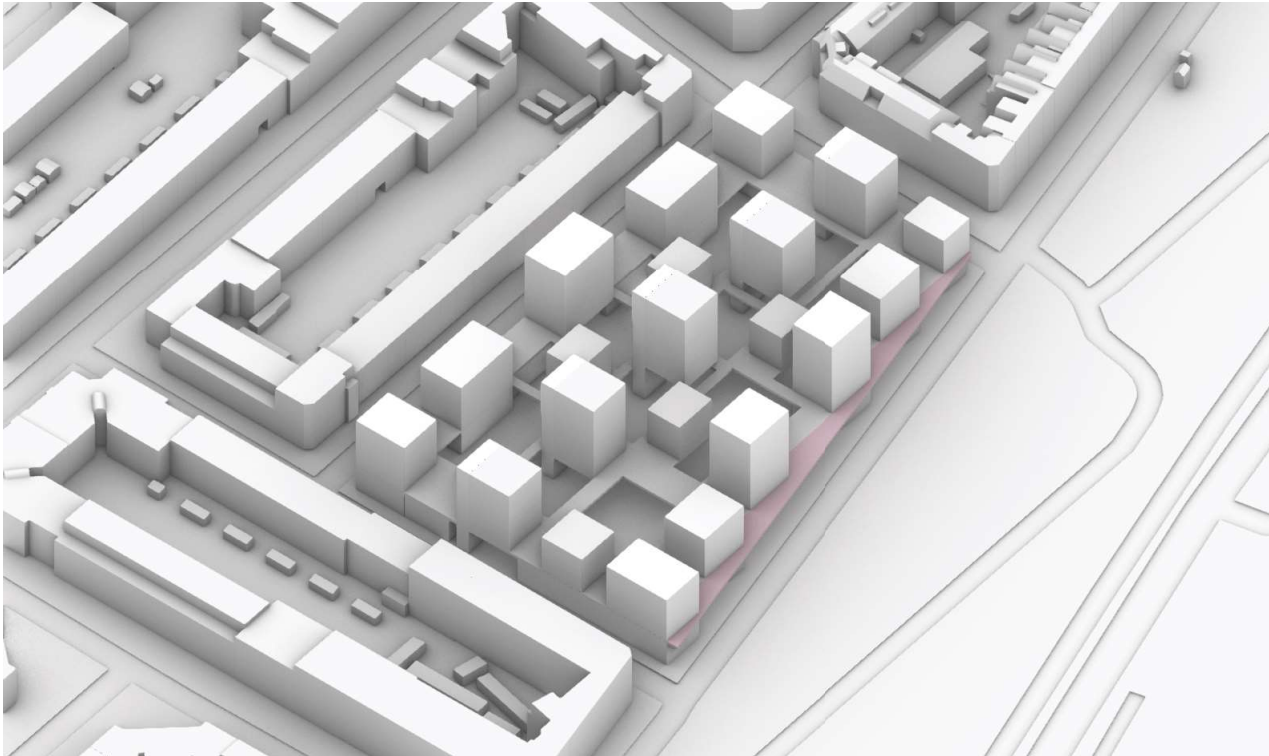

STEP 7

/stretch the platform to respond to special condition in the context (e.g. park) to address the entrance.

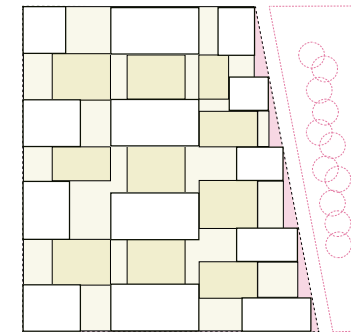

- extended platform
- platform
- park

system concept

HOUSING COMPLEX



INTRODUCTION

SUMMARY OF THE RESEARCH

DESIGN BRIEF

SYSTEM CONCEPT

DESIGN PROPOSAL

DRAWINGS

GROUP SITE PLAN 1:10000



SITE PLAN 1:1000



URBAN IMPLEMENTATION 1:500

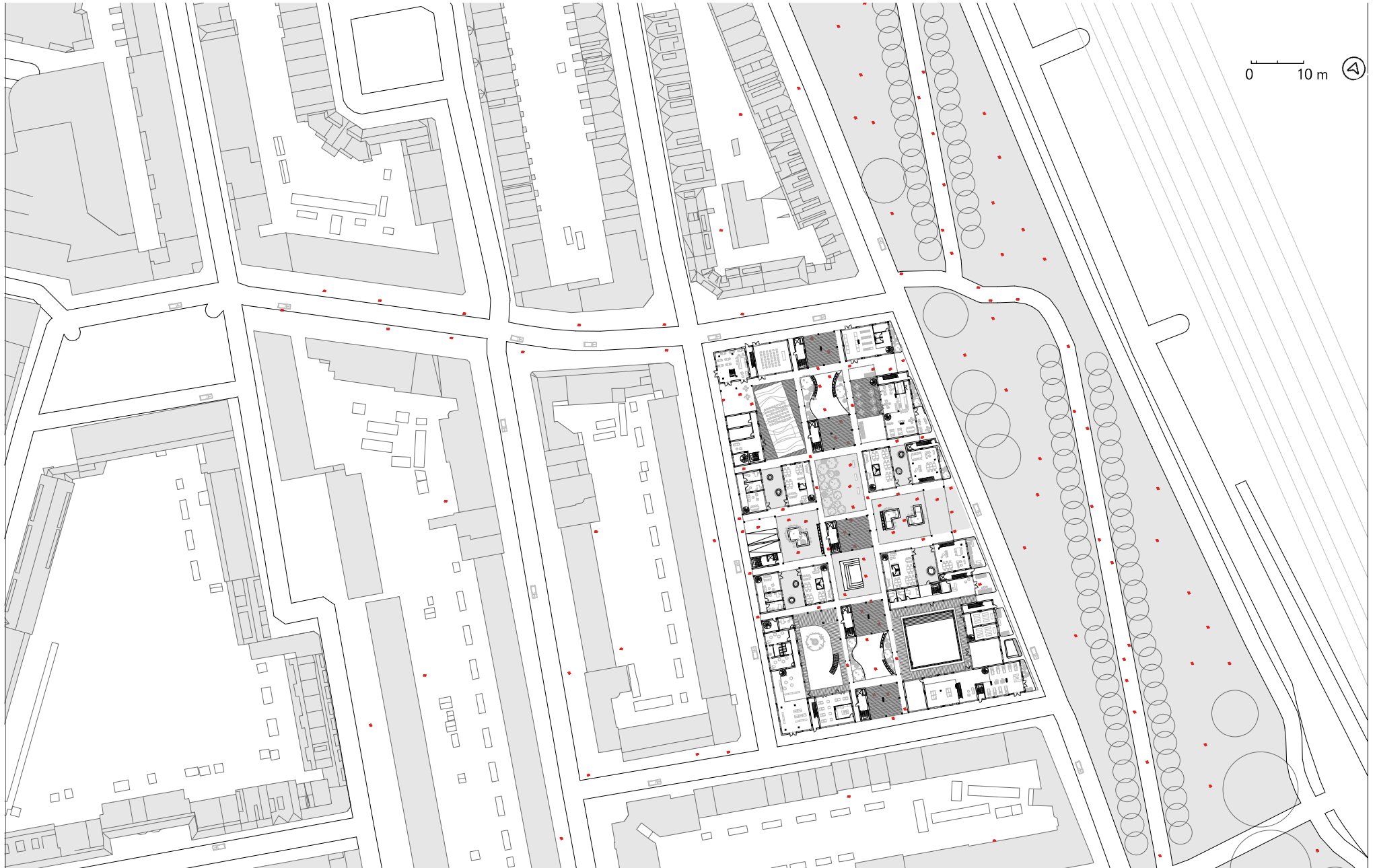

LEVEL -1 - PARKING

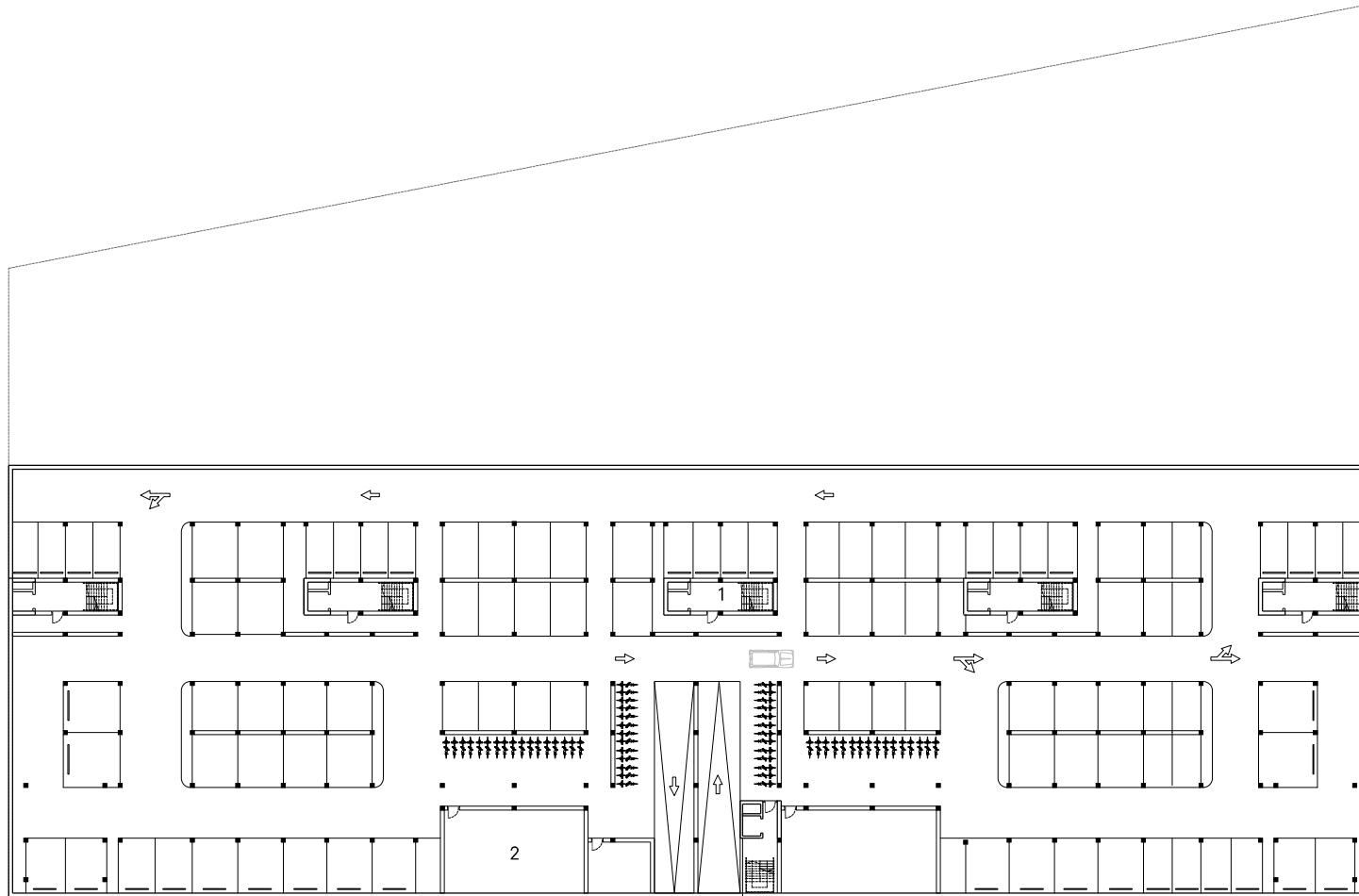

1 circulation core
2 service room

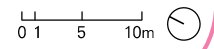

GROUND FLOOR - MULTIPLE COURTYARDS

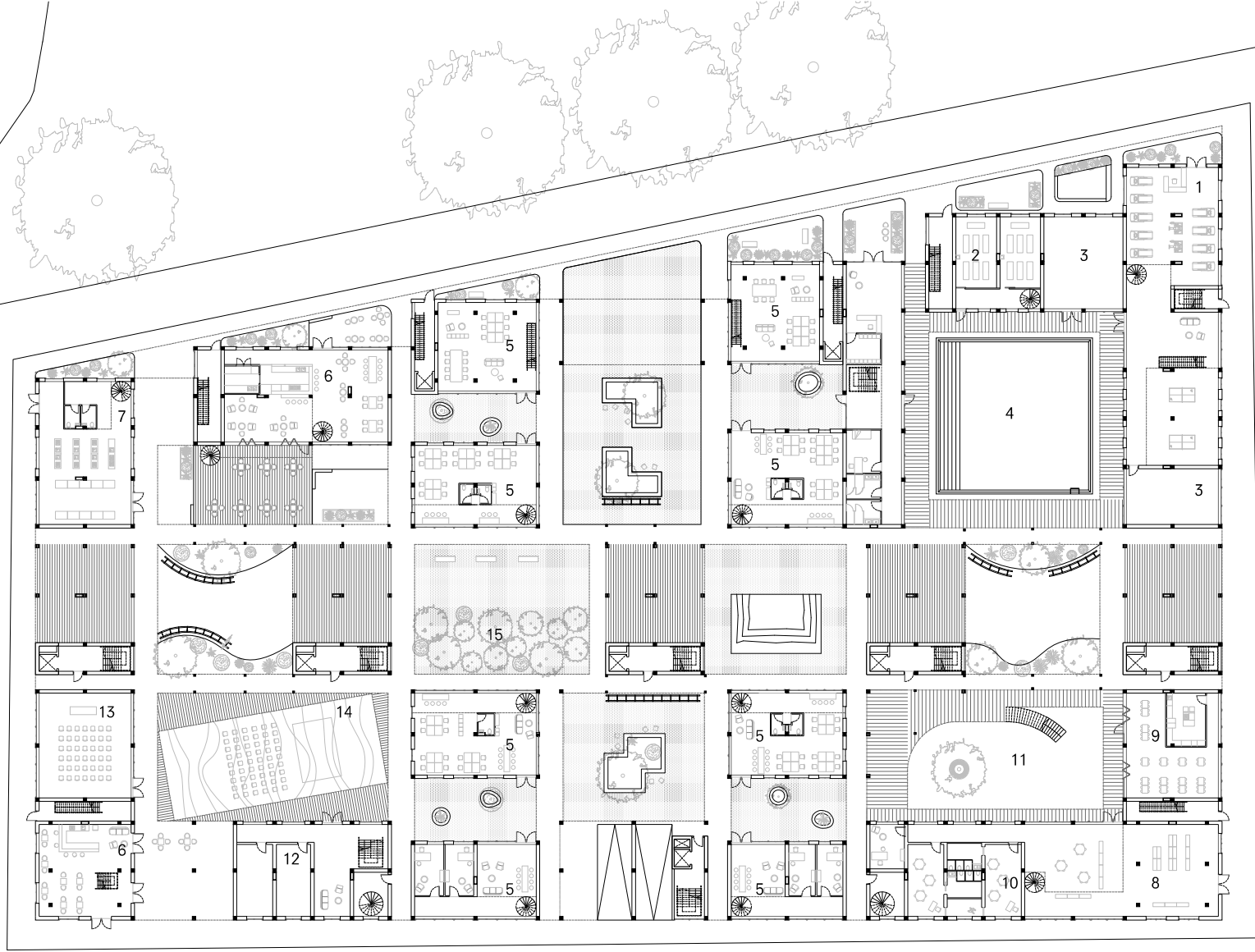

- 1 gym
- 2 yoga room
- 3 sports activity room
- 4 swimming pool
- 5 shared work space
- 6 cafe
- 7 cooking school
- 8 nursery entrance hall
- 9 dining hall
- 10 classrooms
- 11 playground
- 12 community office
- 13 event space
- 14 outdoor event space
- 15 tiny forest

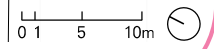

GROUND FLOOR - VIEW TO THE COURTYARD



GROUND FLOOR - MULTIPLE COURTYARDS

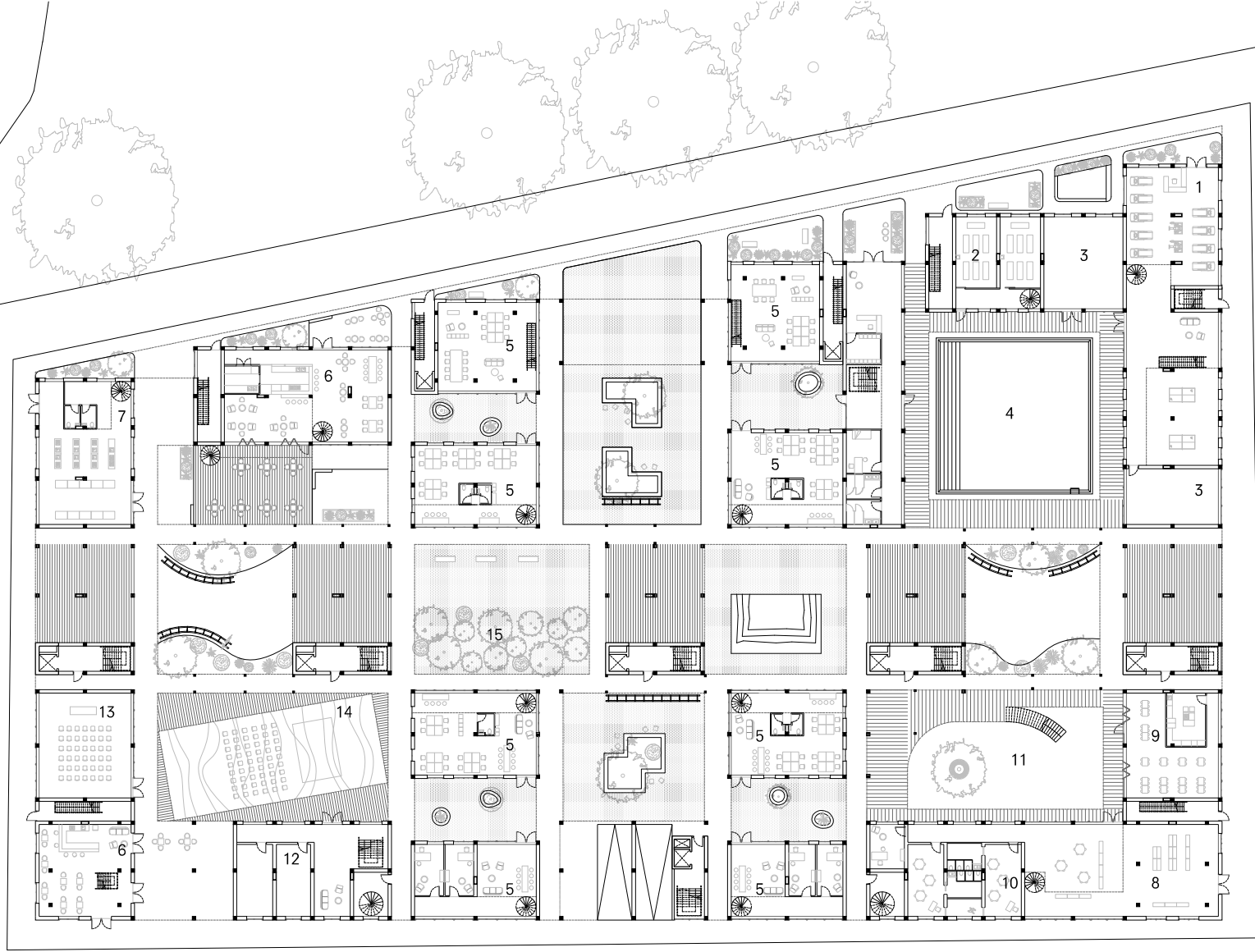

- 1 gym
- 2 yoga room
- 3 sports activity room
- 4 swimming pool
- 5 shared work space
- 6 cafe
- 7 cooking school
- 8 nursery entrance hall
- 9 dining hall
- 10 classrooms
- 11 playground
- 12 community office
- 13 event space
- 14 outdoor event space
- 15 tiny forest

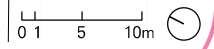

GROUND FLOOR - VIEW TO THE COURTYARD



GROUND FLOOR - MULTIPLE COURTYARDS

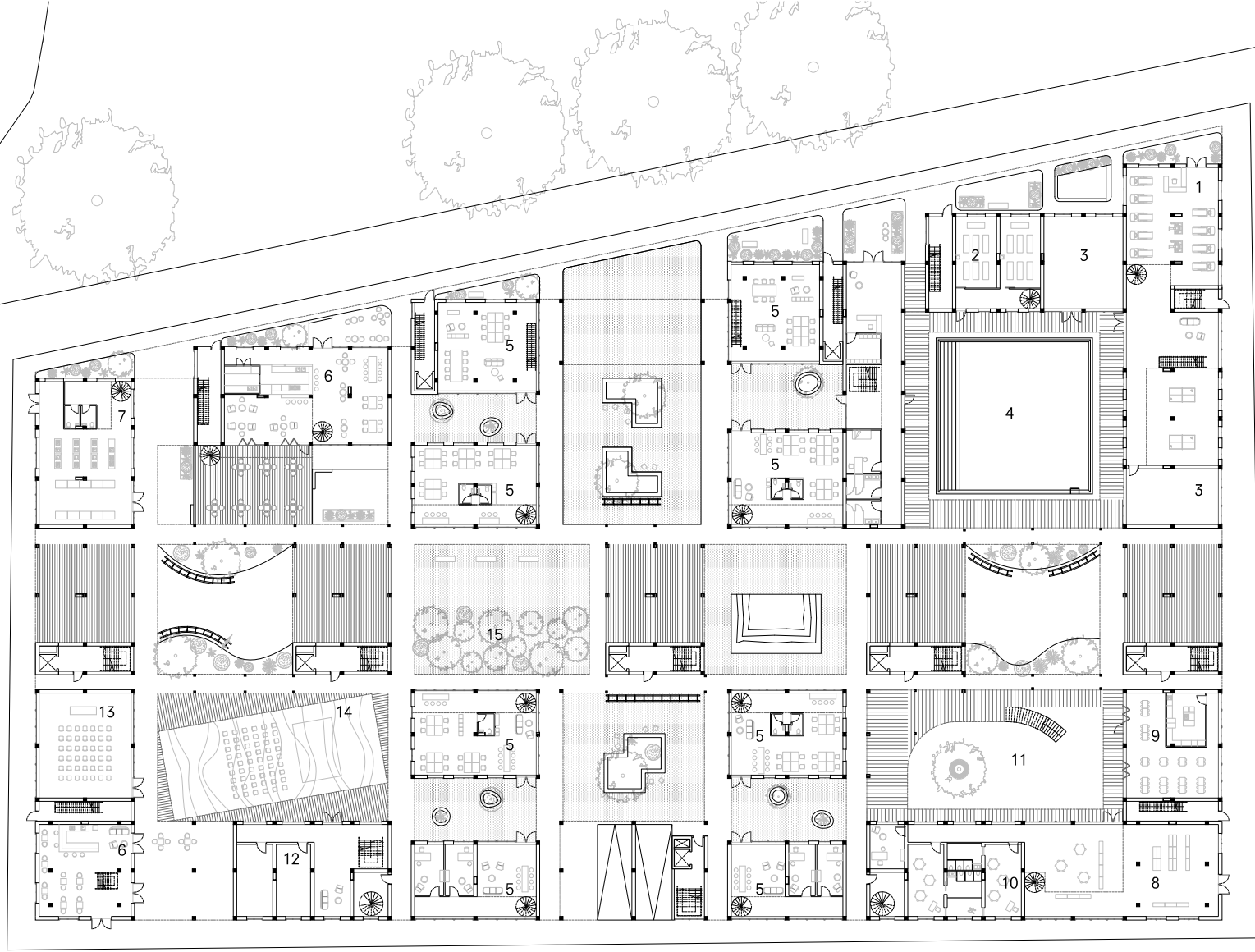

- 1 gym
- 2 yoga room
- 3 sports activity room
- 4 swimming pool
- 5 shared work space
- 6 cafe
- 7 cooking school
- 8 nursery entrance hall
- 9 dining hall
- 10 classrooms
- 11 playground
- 12 community office
- 13 event space
- 14 outdoor event space
- 15 tiny forest

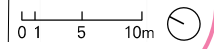

GROUND FLOOR - VIEW TO THE COURTYARD



GROUND FLOOR - CONTINUATION OF GREEN

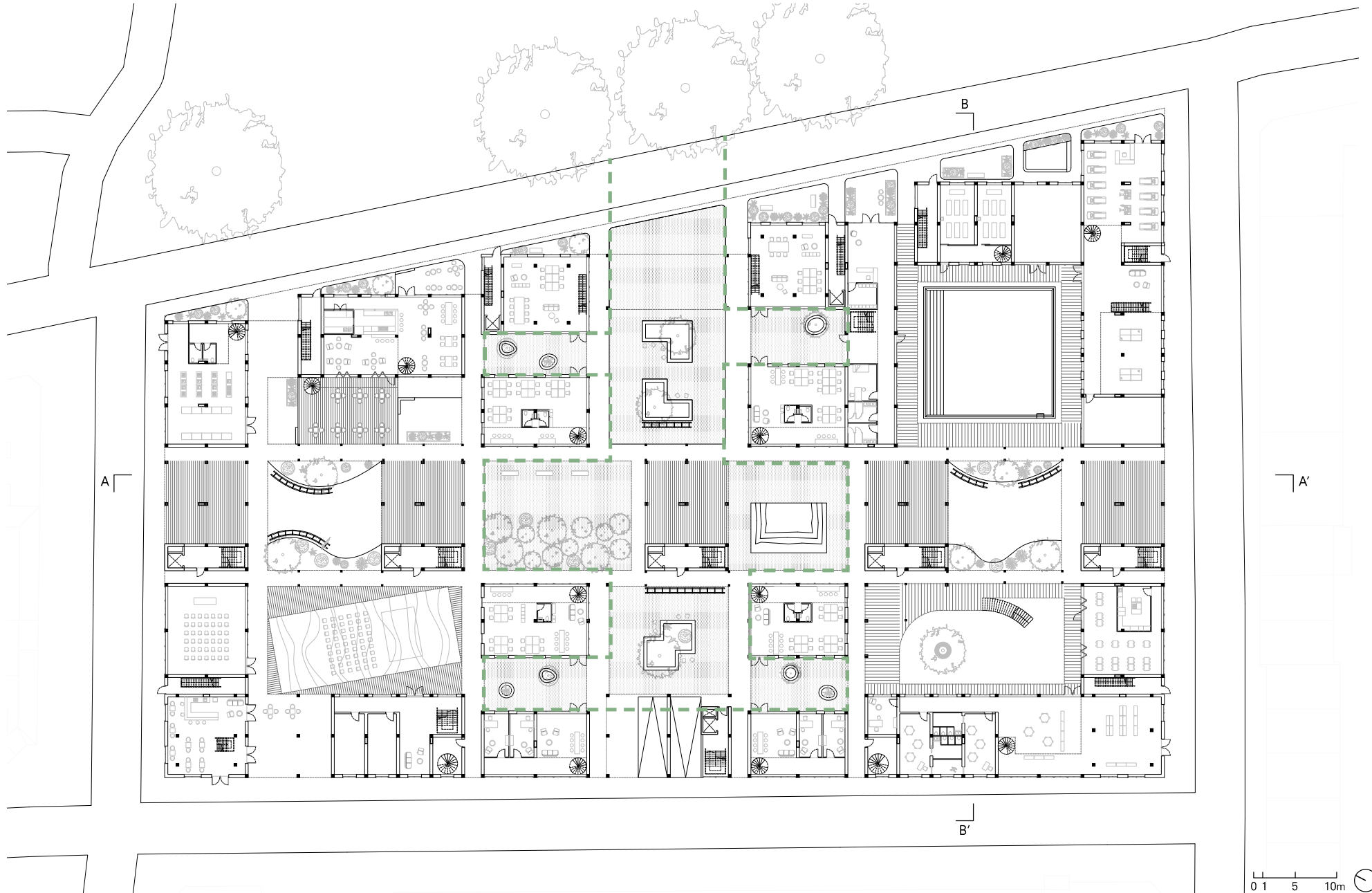

GROUND FLOOR - CONTINUATION OF GREEN



GROUND FLOOR - CIRCULATION

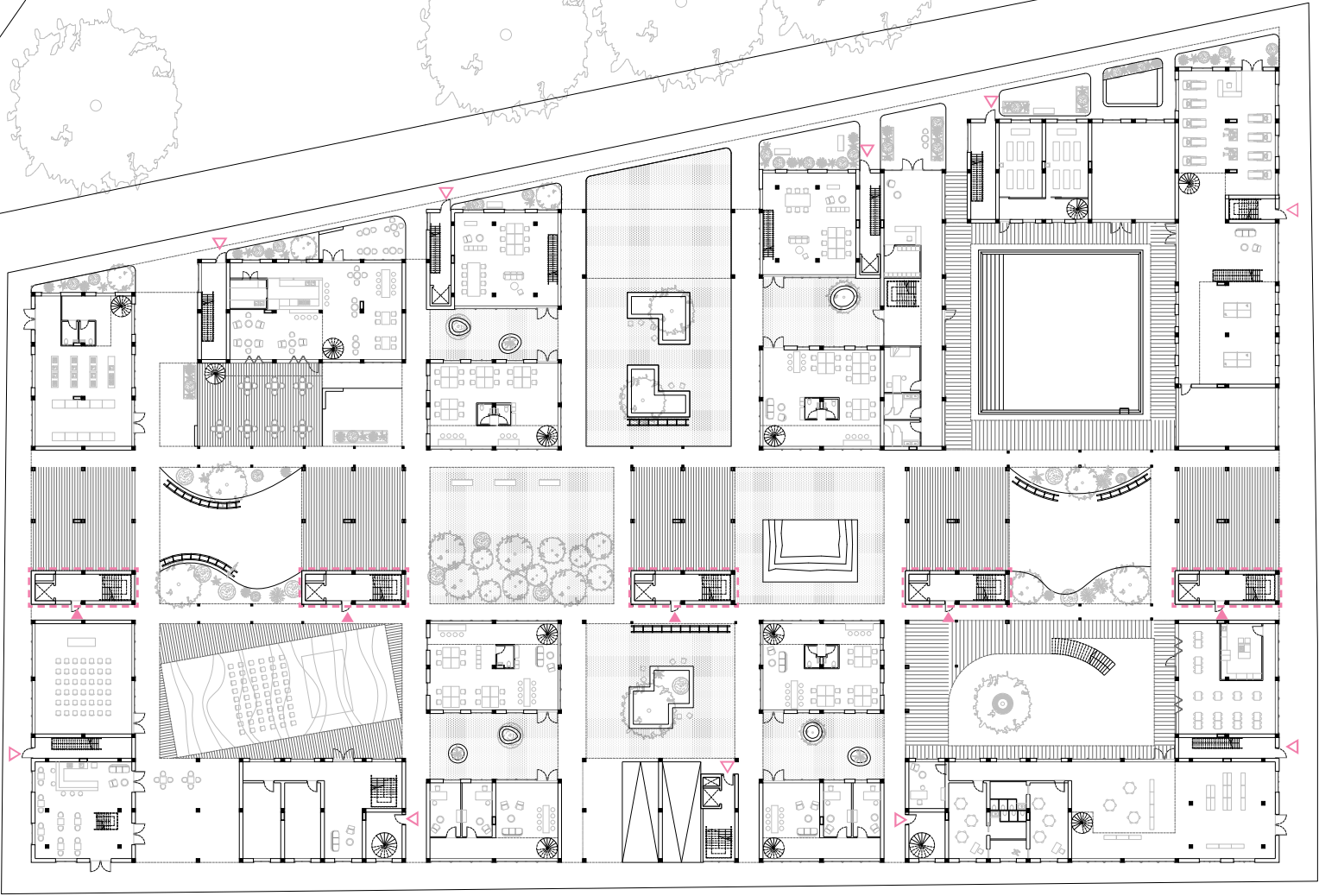

▲ entrances to the core
▲ entrances to individual volumes

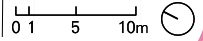

GROUND FLOOR - ENTRANCE TO THE CORE



LEVEL 1

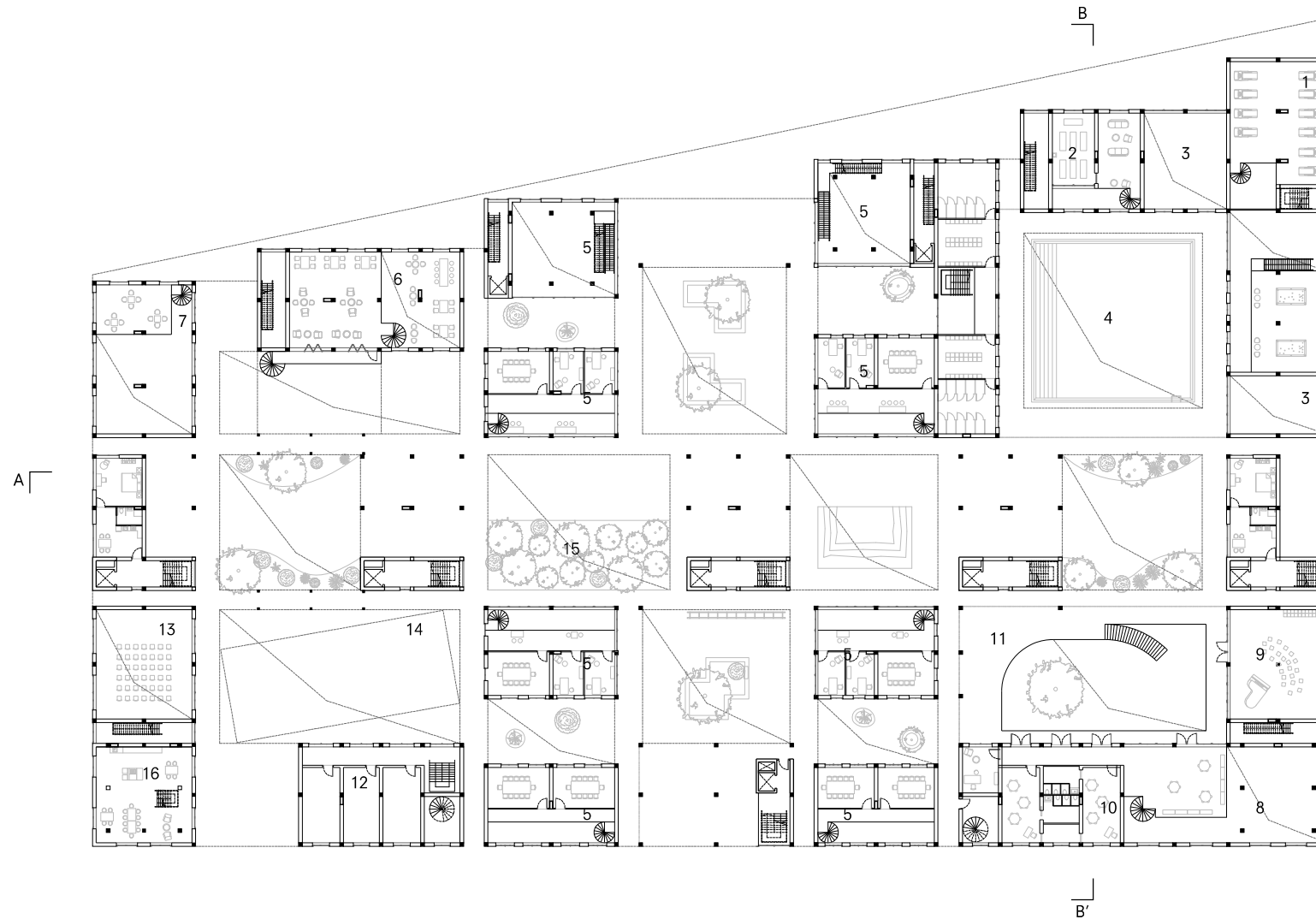

- 1 gym
- 2 yoga room
- 3 sports activity room
- 4 swimming pool
- 5 shared work space
- 6 cafe
- 7 cooking school
- 8 nursery entrance hall
- 9 bigger classroom
- 10 classrooms
- 11 outdoor gallery
- 12 community room
- 13 event space
- 14 outdoor event space
- 15 tiny forest
- 16 shared kitchen

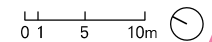

LEVEL 2 - PLATFORM

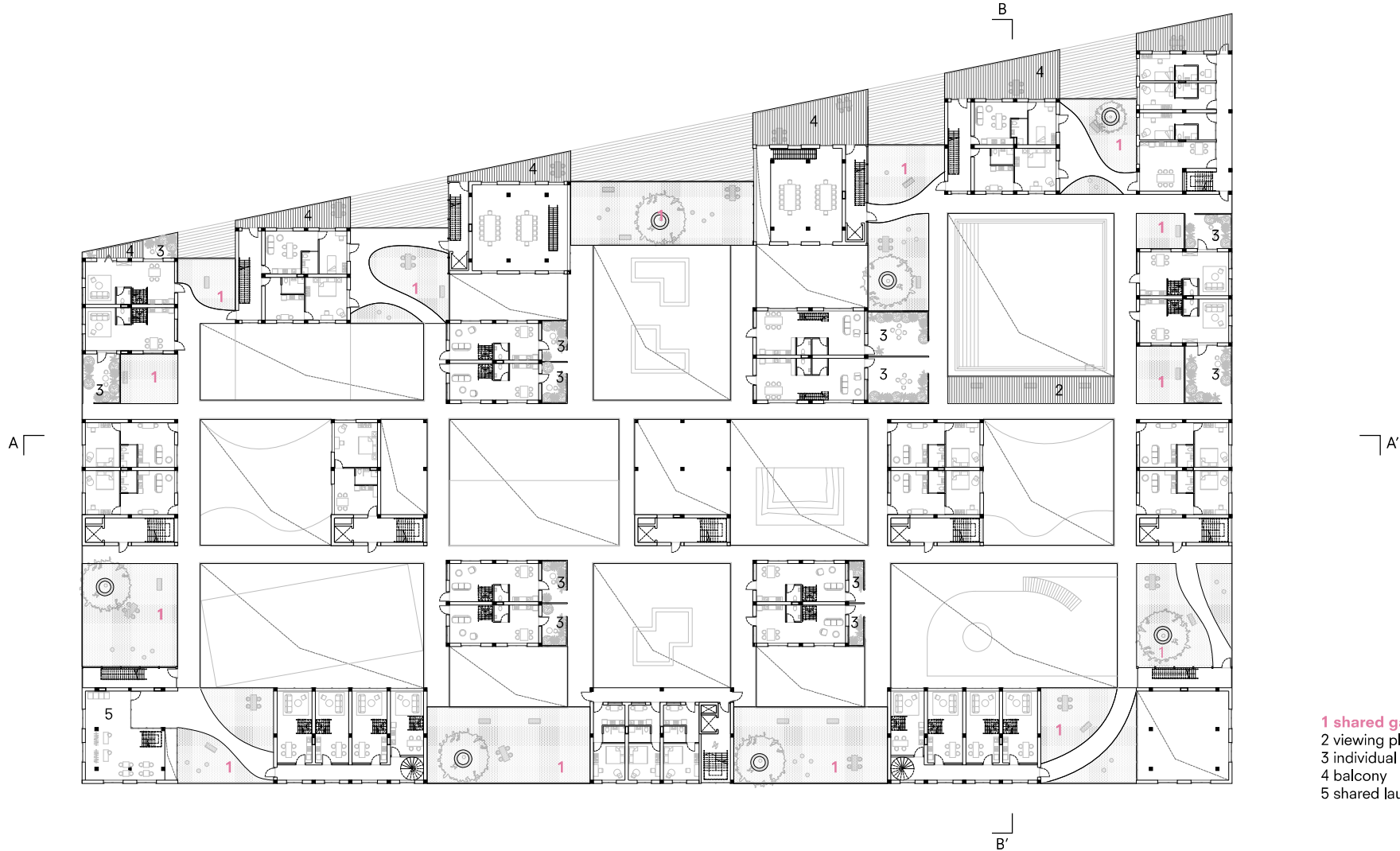

- 1 shared garden
- 2 viewing platform
- 3 individual garden
- 4 balcony
- 5 shared laundry



LEVEL 2 - PERSPECTIVE TO THE PLATFORM



LEVEL 2 - PLATFORM

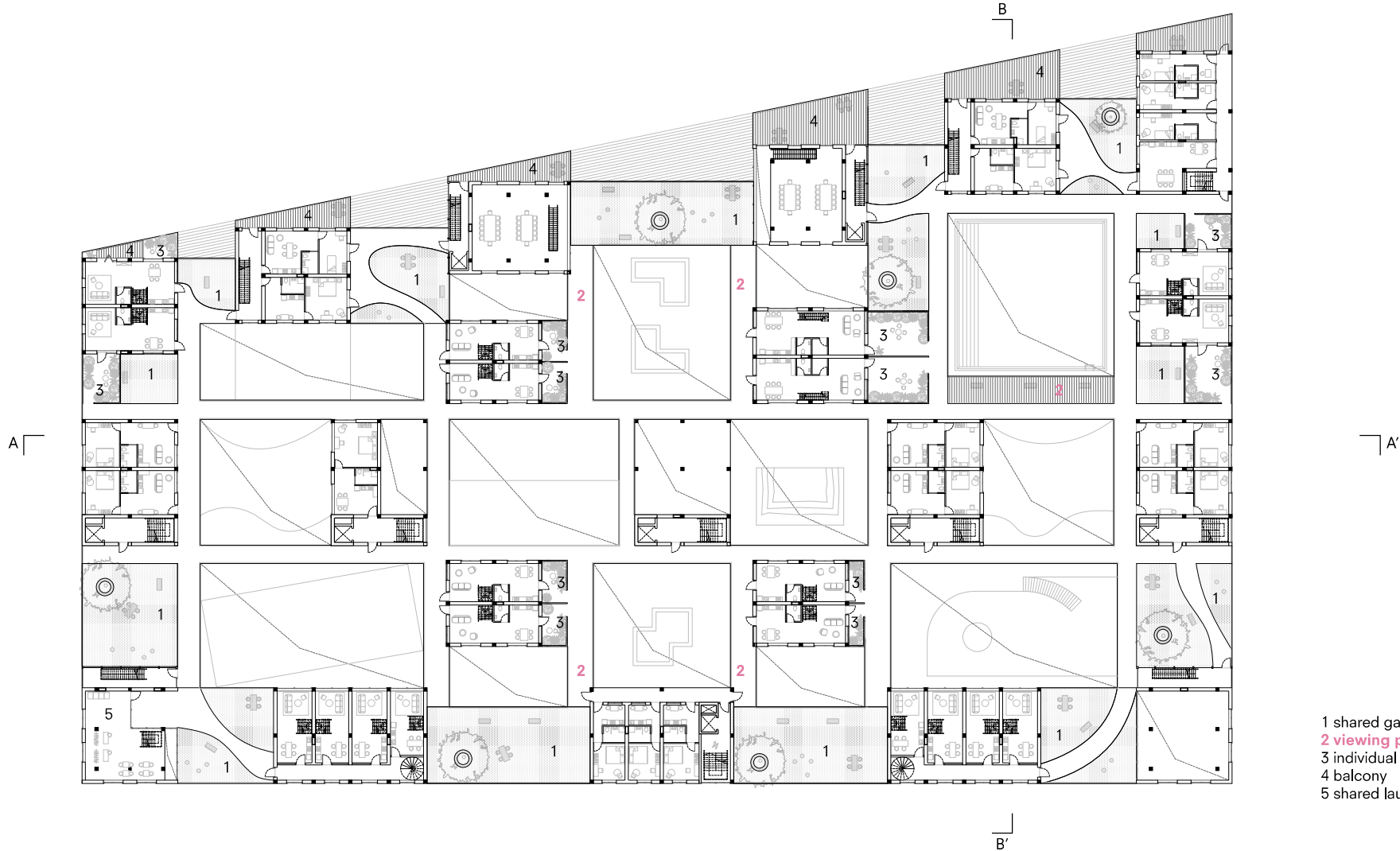

- 1 shared garden
- 2 viewing platform
- 3 individual garden
- 4 balcony
- 5 shared laundry



LEVEL 2 - PERSPECTIVE FROM PLATFORM



LEVEL 2 - PLATFORM

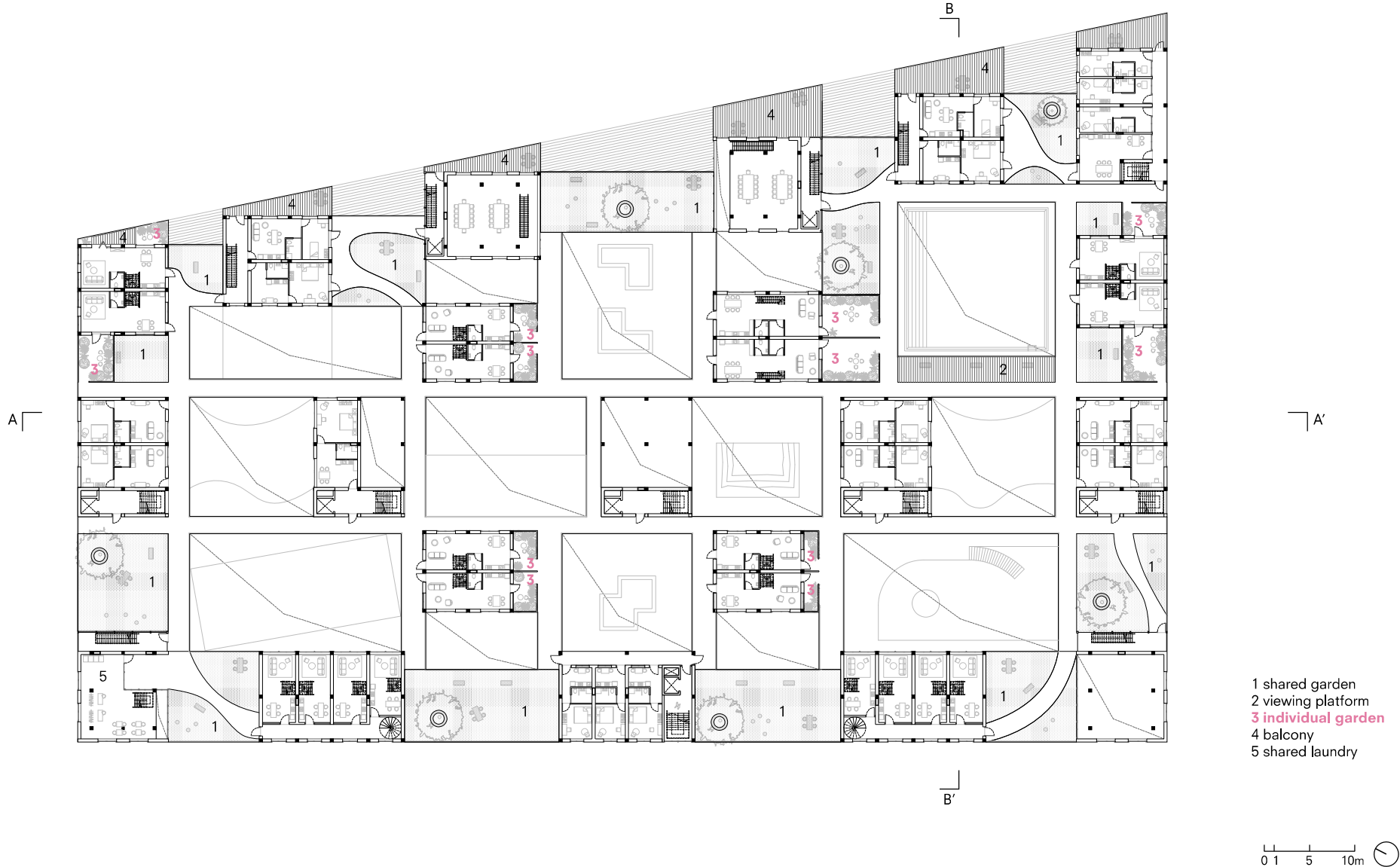

LEVEL 2 - PERSPECTIVE TO THE GARDEN



LEVEL 2 - PLATFORM

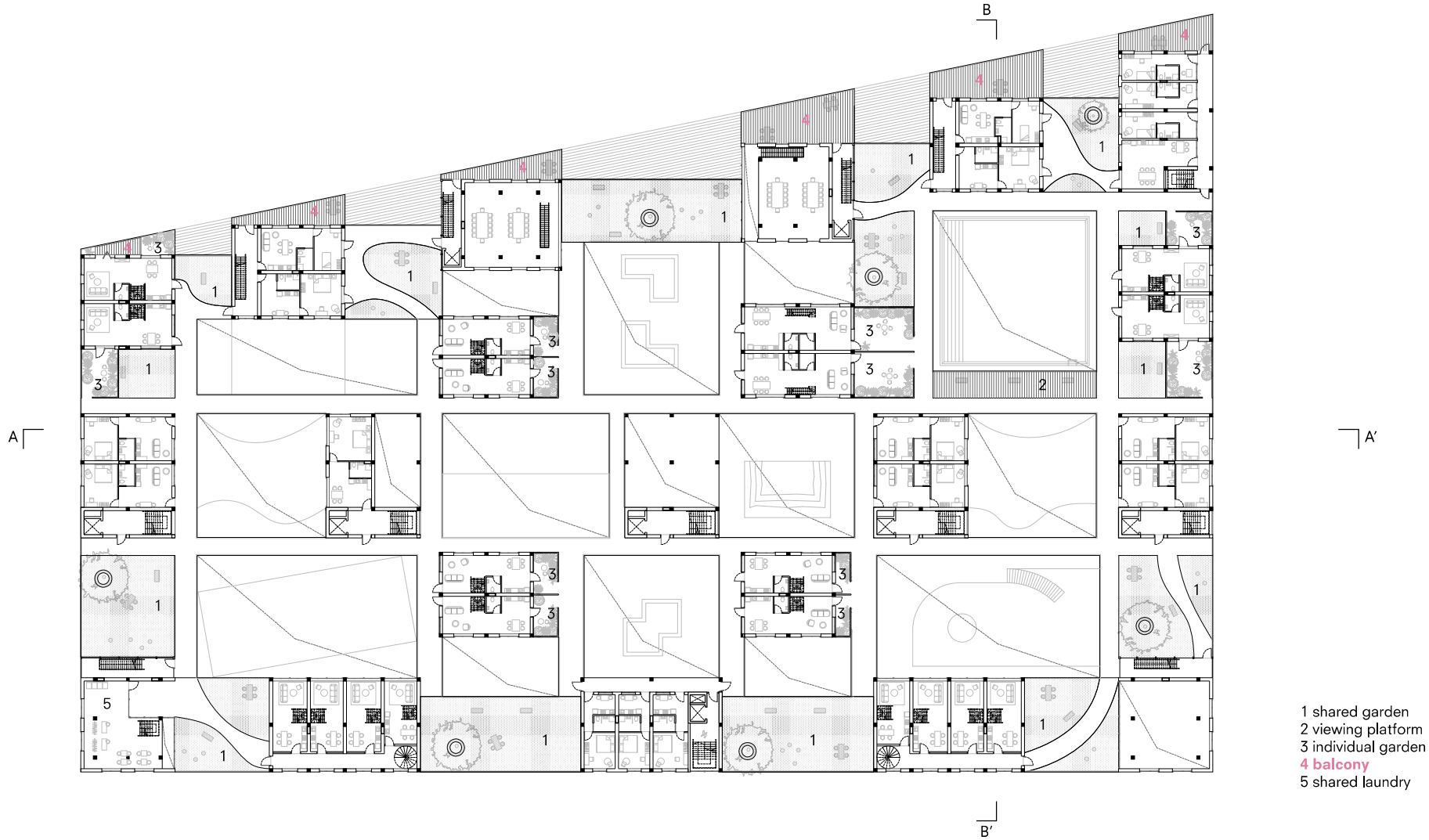

- 1 shared garden
- 2 viewing platform
- 3 individual garden
- 4 balcony
- 5 shared laundry

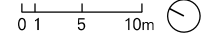

LEVEL 2 - PERSPECTIVE TO THE BALCONY



LEVEL 3 - HOUSING

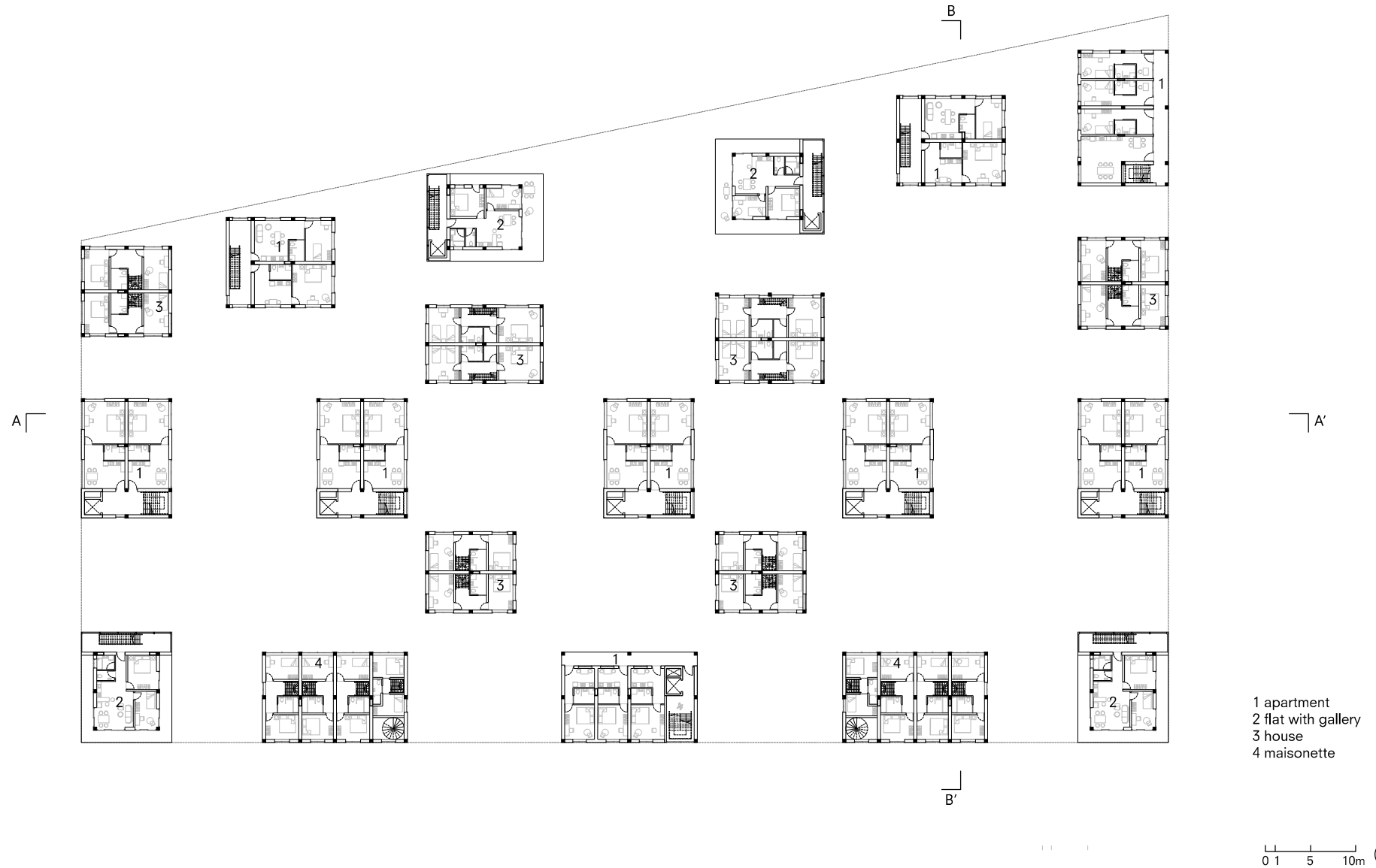

SECTION AA'

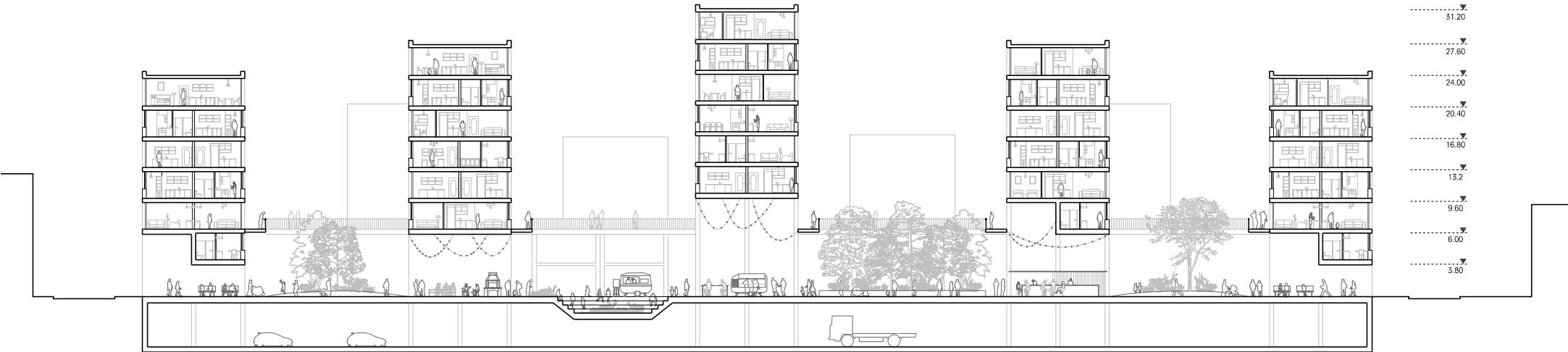

0 1 5 10m

SECTION BB'

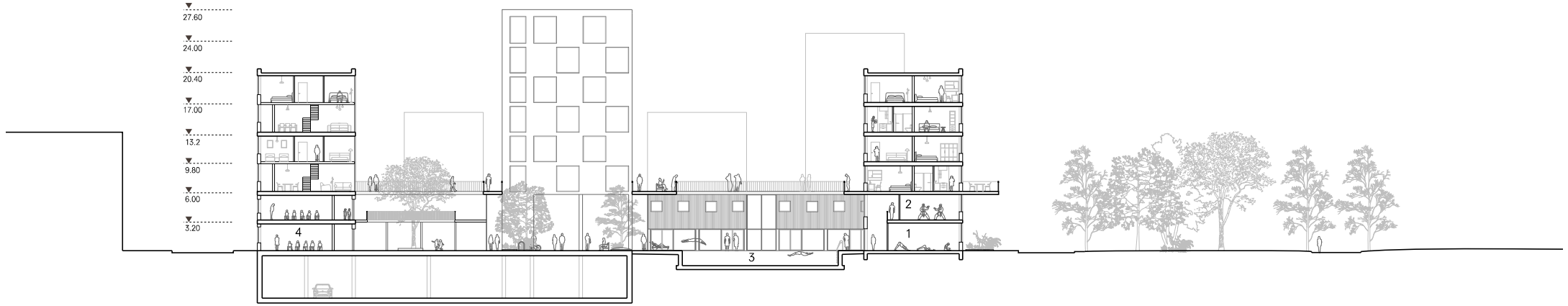

- 1 yoga room
- 2 activity room
- 3 swimming pool
- 4 classroom

0 1 5 10m

MATERIALIZATION

materialization

ELEVATION



Elevation towards residential area

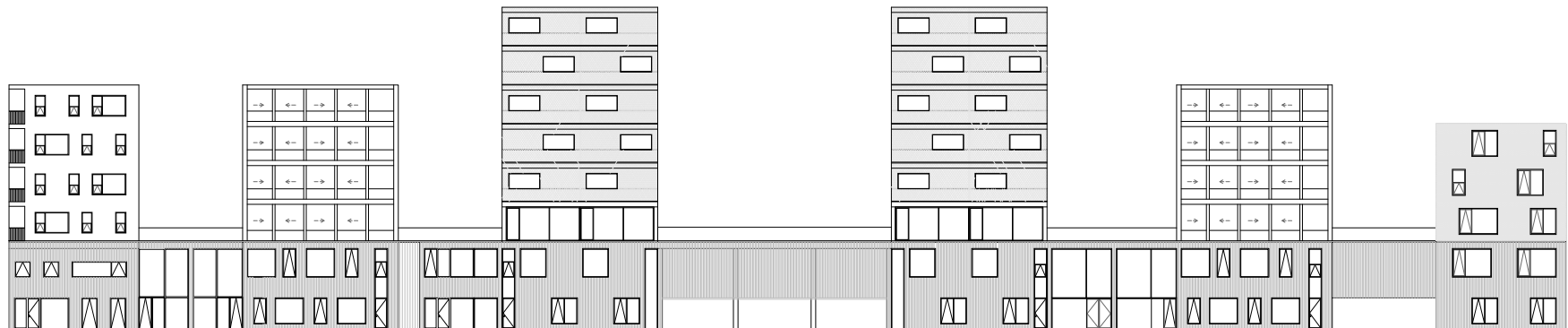

Elevation towards park

0 1 5 10m

materialization

AXONOMETRIC VIEW



PERSPECTIVE: VIEW TO THE CENTRAL SPINE

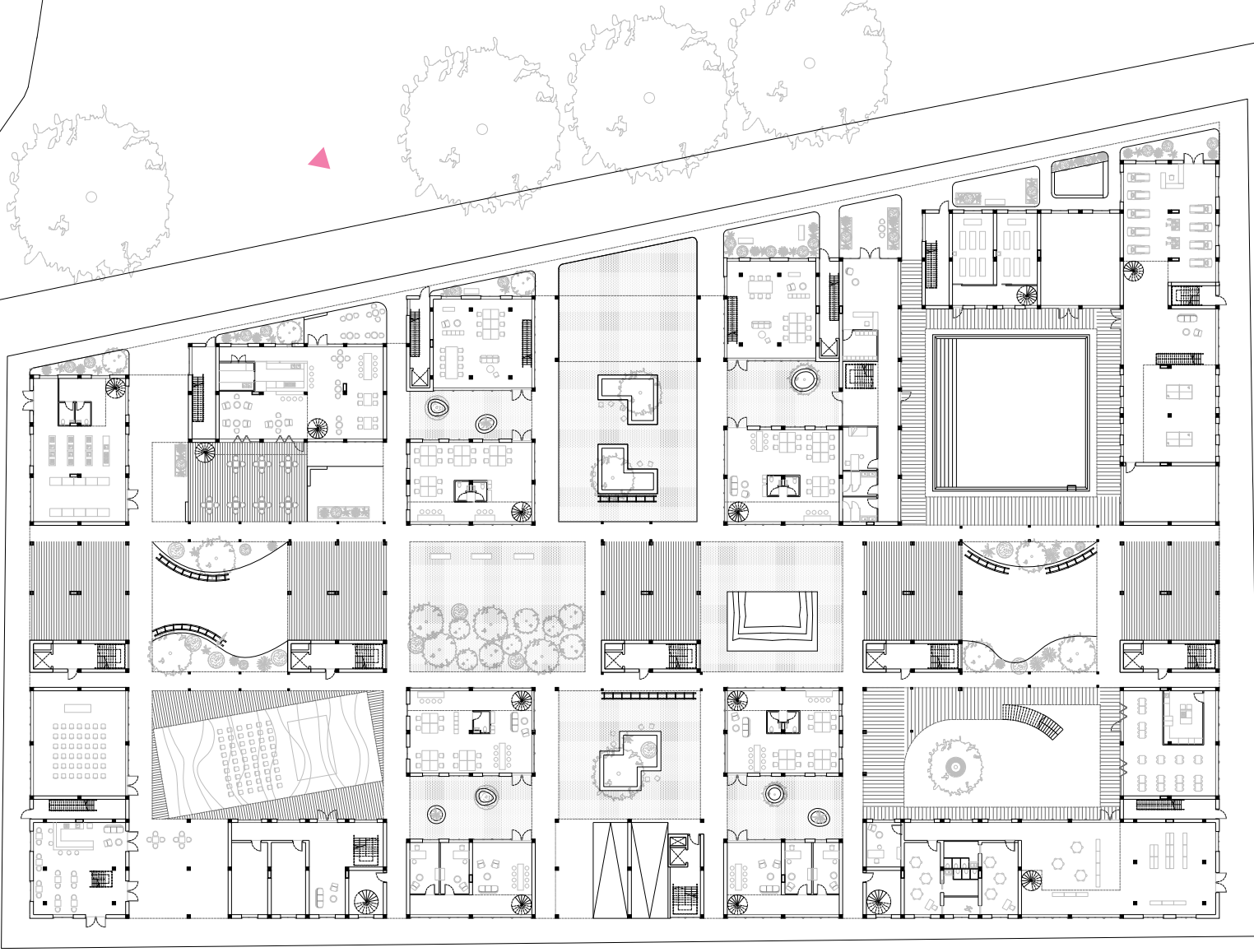

PERSPECTIVE: VIEW TO THE EAST FACADE



PERSPECTIVE: VIEW TO THE CENTRAL SPINE

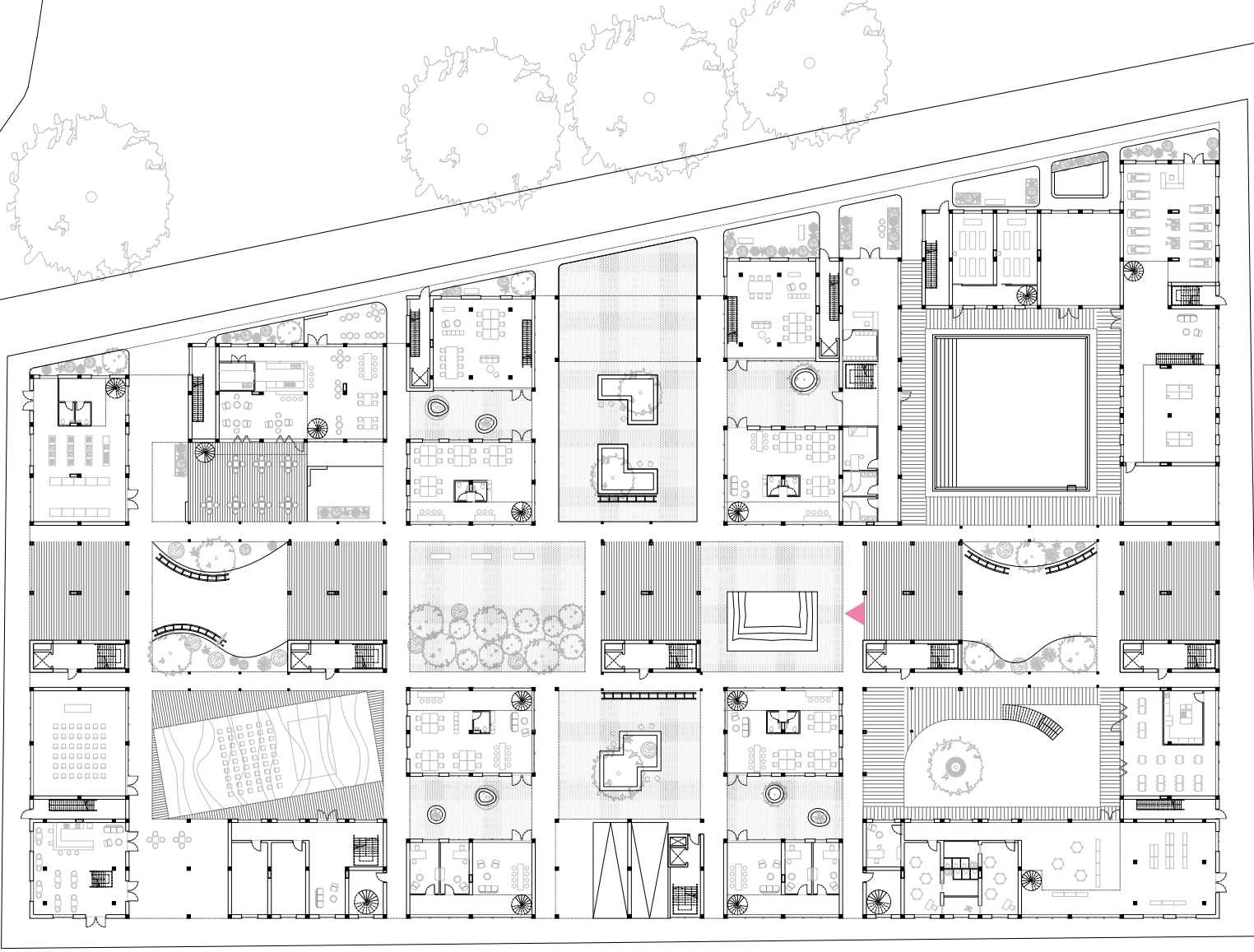

PERSPECTIVE: VIEW TO THE CENTRAL SPINE



FLEXIBILITY & DENSITY

TYOLOGY FOR FLEXIBILITY

A. TOWERS



A1 apartment



A2 flat with gallery



A3 maisonette



A4 house

B. BASE

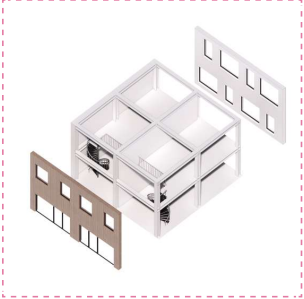

B1

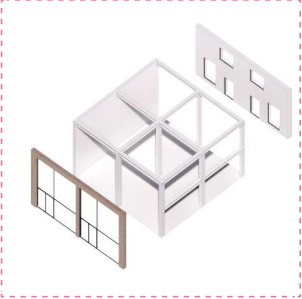

B2

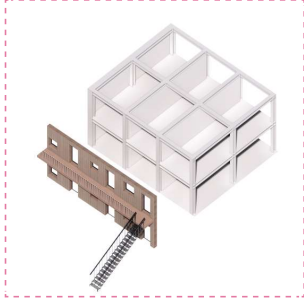

B3

C. SPINE



C1 apartment + maisonette

flexibility & density

APARTMENT

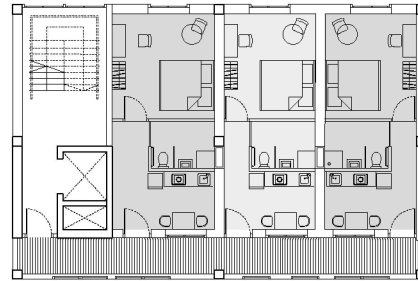

densification: 3 apartments

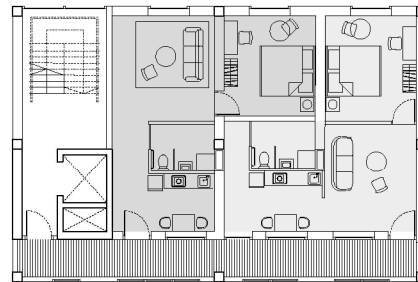

densification: 2 apartments

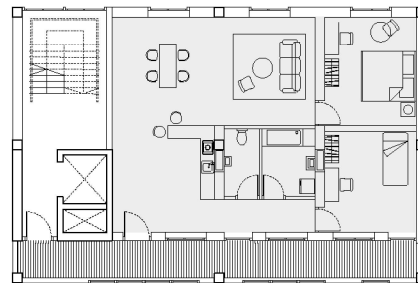

dilution: 1 apartment

A. TOWERS

A1 Apartment
maximum unit number (densification):
30
minimum unit number (dilution):
10



0 1 2 5m

flexibility & density

FLAT WITH GALLERY

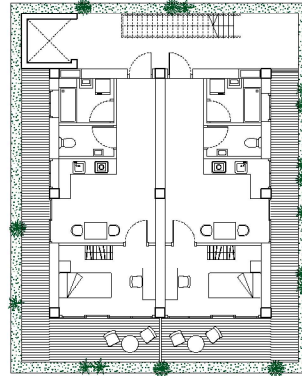

densification: 2 flats

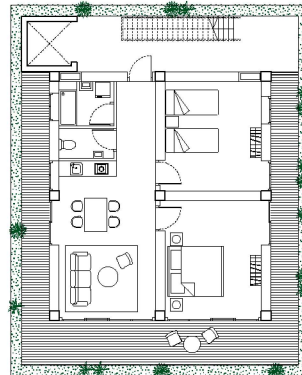

dilution: 1 flat

A. TOWERS

A2 Flat with gallery
maximum unit number (densification):
36
minimum unit number (dilution):
18



0 1 2 5m

flexibility & density

MAISONNETTE

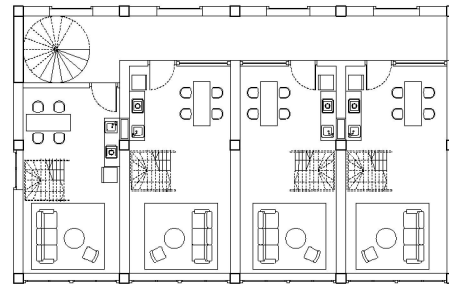

level 1

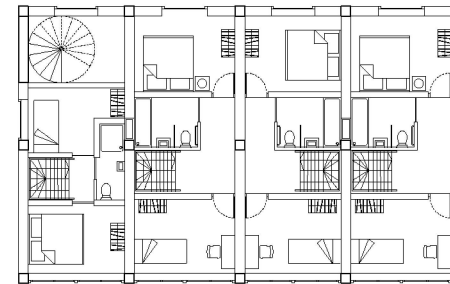

level 2

densification: 4 maisonnettes

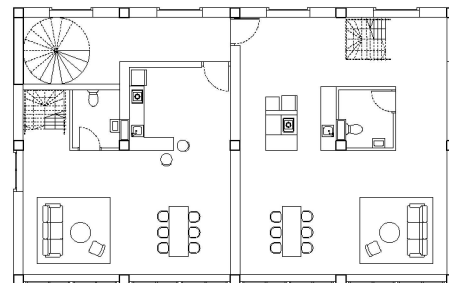

level 1

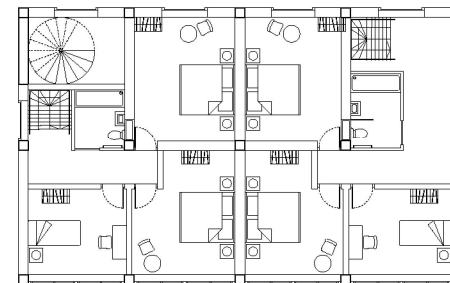

level 2

dilution: 2 larger maisonnettes

A. TOWERS

A3 Maisonette
maximum unit number (densification):
28
minimum unit number (dilution):
8



0 1 2 5m

HOUSE

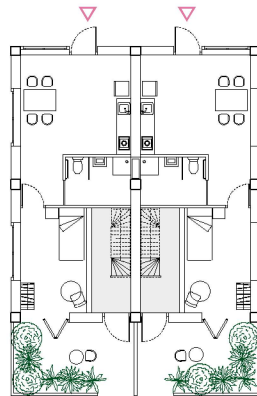
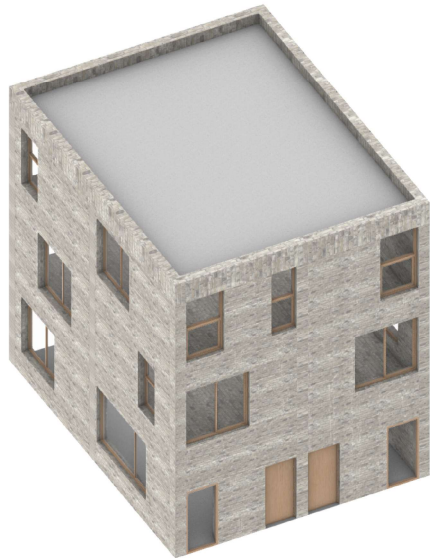

level 1

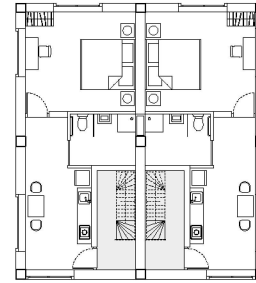

level 2

densification: 6 apartments in one block

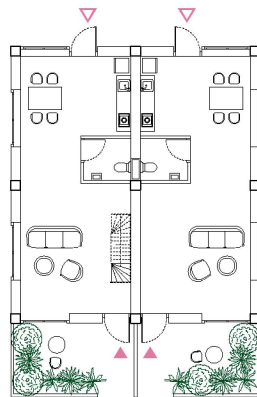

level 1

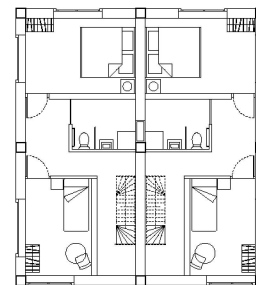

level 2

dilution: 2 houses in block

A. TOWERS

A4 House
maximum unit number (densification):
18
minimum unit number (dilution):
6



- ▲ shared entrance
- △ individual entrance

B1 TYPOLOGY UNDER THE PLATFORM

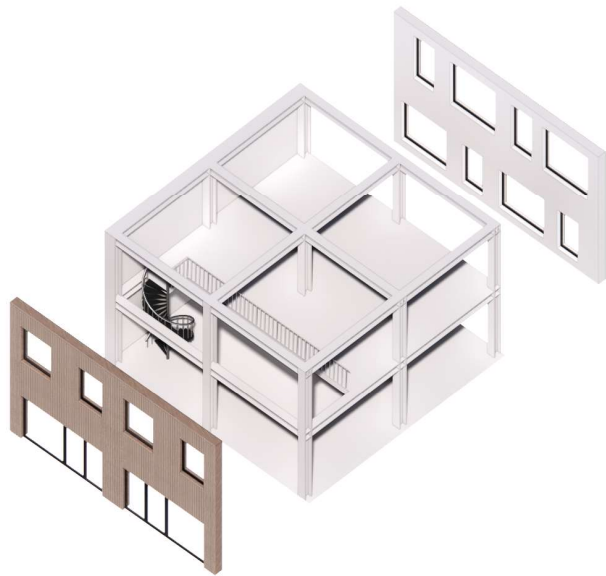

dilution: public programs



densification: 2 maisonette

B. BASE

B1
maximum unit number (densification):
14
minimum unit number (dilution):
0



B2 TYPOLOGY UNDER THE PLATFORM

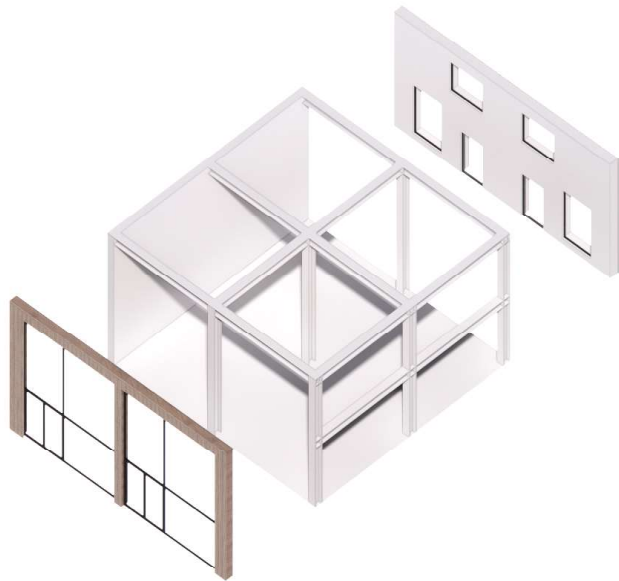

dilution: public programs



densification: 2 maisonette

B. BASE

B2
maximum unit number (densification):
21
minimum unit number (dilution):
0



B3 TYPOLOGY UNDER THE PLATFORM



dilution: public programs



densification: 6 apartments

B. BASE

B3
maximum unit number (densification):
24
minimum unit number (dilution):
0



C1 APARTMENT + MAISONETTE

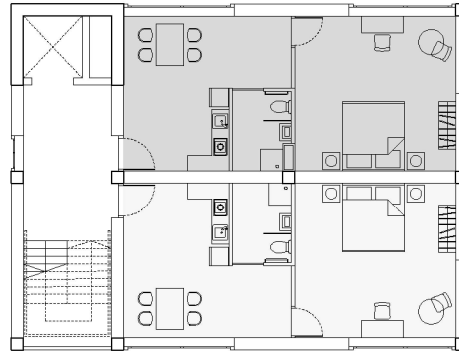
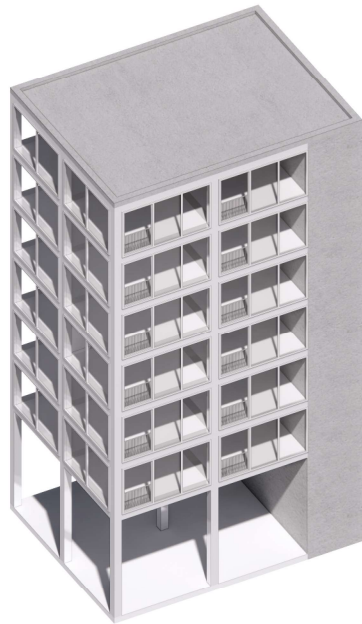

densification: 2 units

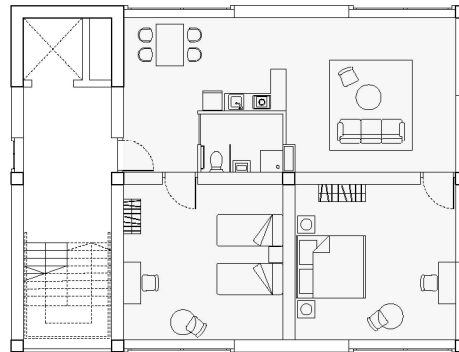

dilution: one unit

C. SPINE

C1 apartment + maisonette
maximum unit number (densification):
66
minimum unit number (dilution):
29



0 1 2 5m

flexibility & density

C1 APARTMENT + MAISONETTE

C. SPINE

C1 apartment + maisonette
maximum unit number (densification):
66
minimum unit number (dilution):
29



0 1 5 10m

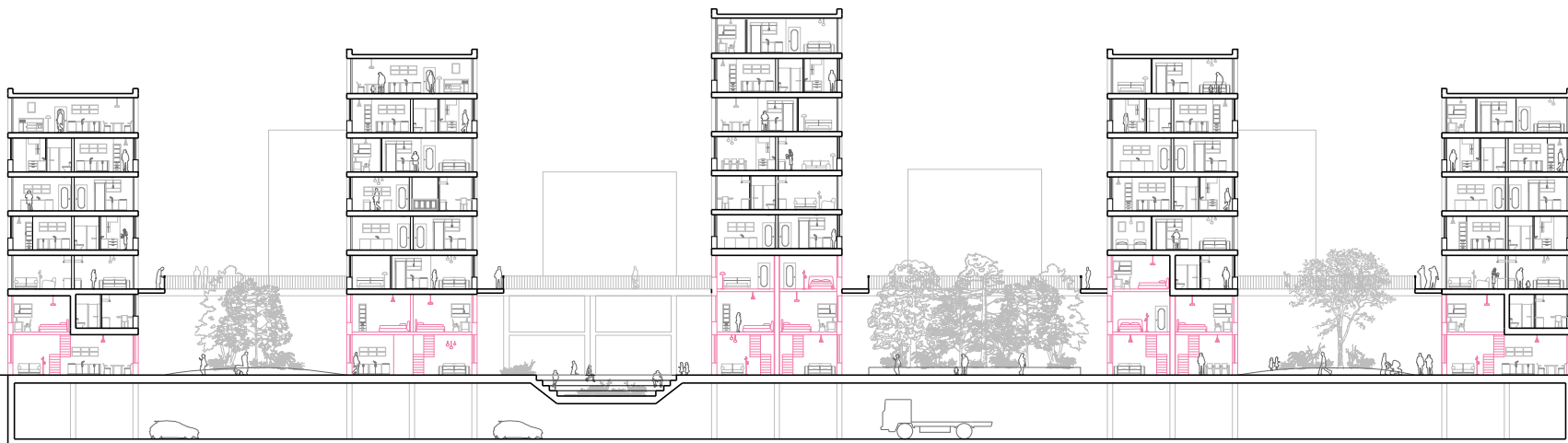

DENSIFICATION PROCESS

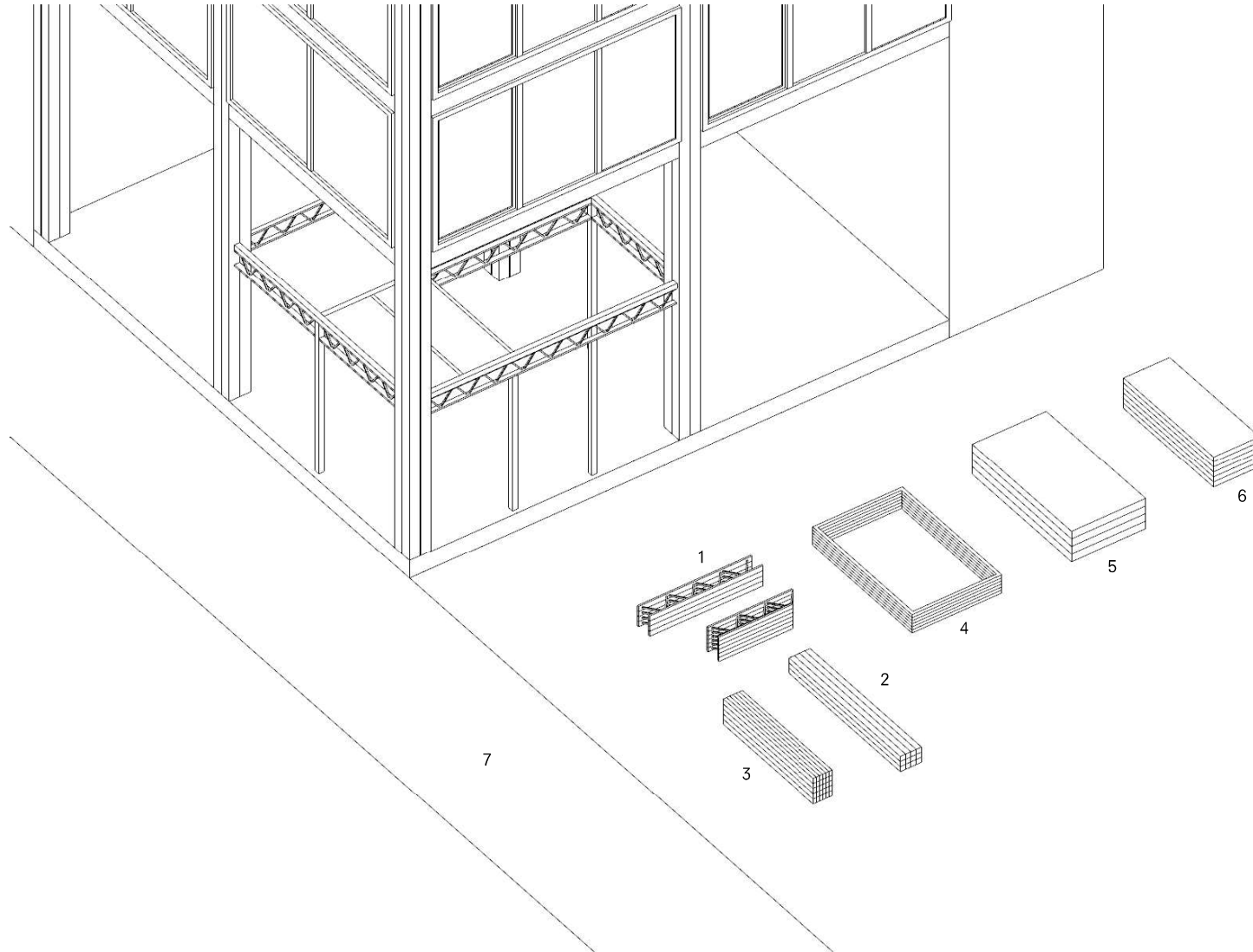

C. SPINE

C1 apartment + maisonette
maximum unit number (densification):
66
minimum unit number (dilution):
29



- 1 lattice truss
- 2 columns
- 3 angles
- 4 window frame
- 5 wall panel
- 6 floor panel
- 7 path of 3m wide

C1 APARTMENT + MAISONETTE

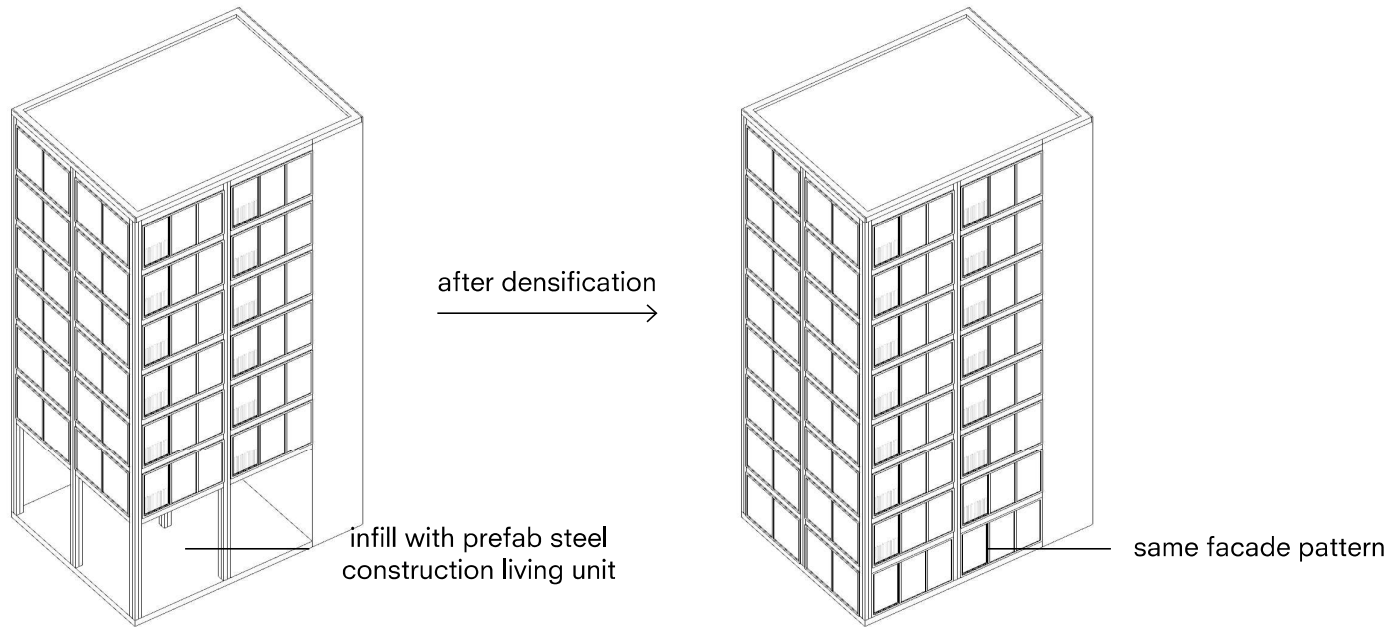

C. SPINE

C1 apartment + maisonette
maximum unit number (densification):
66
minimum unit number (dilution):
29



DETAILING

materialization

1:50 COURTYARD DETAIL

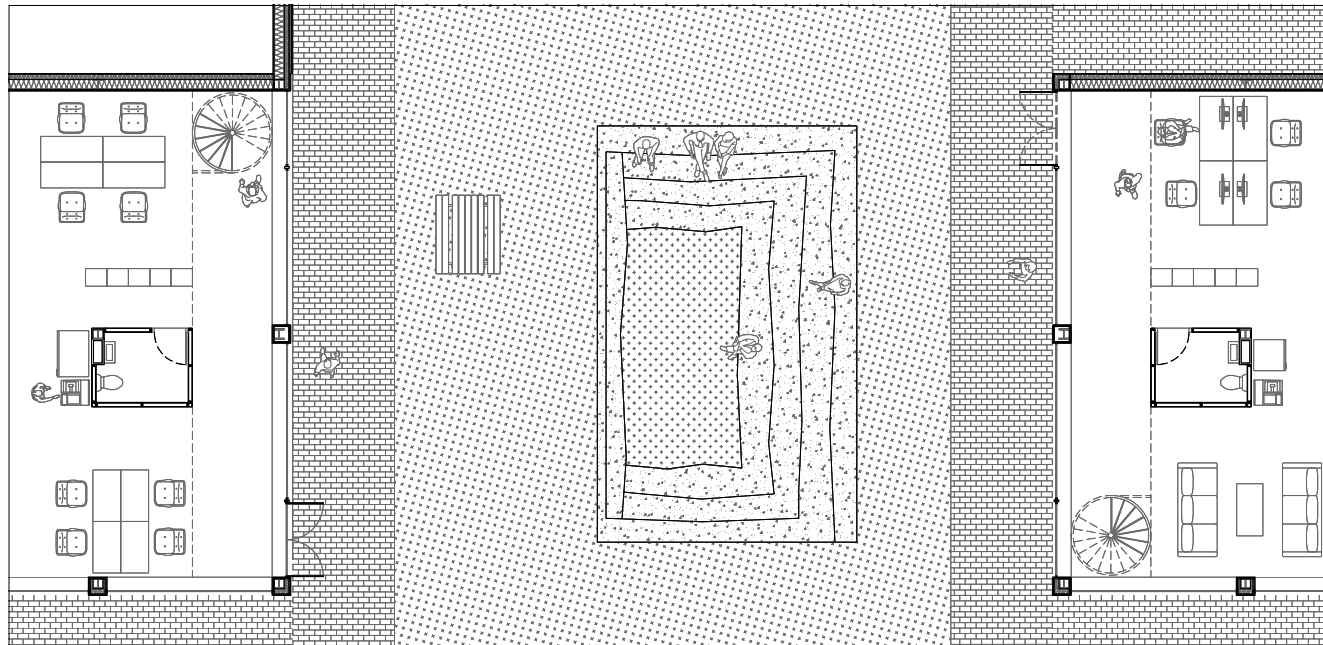
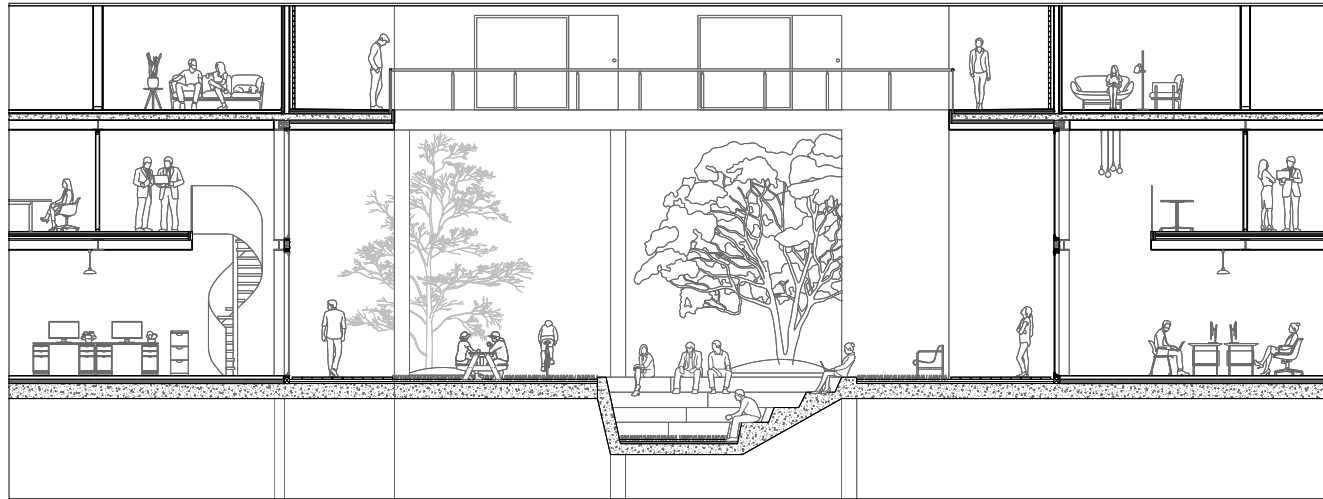

1:50 COURTYARD DETAIL

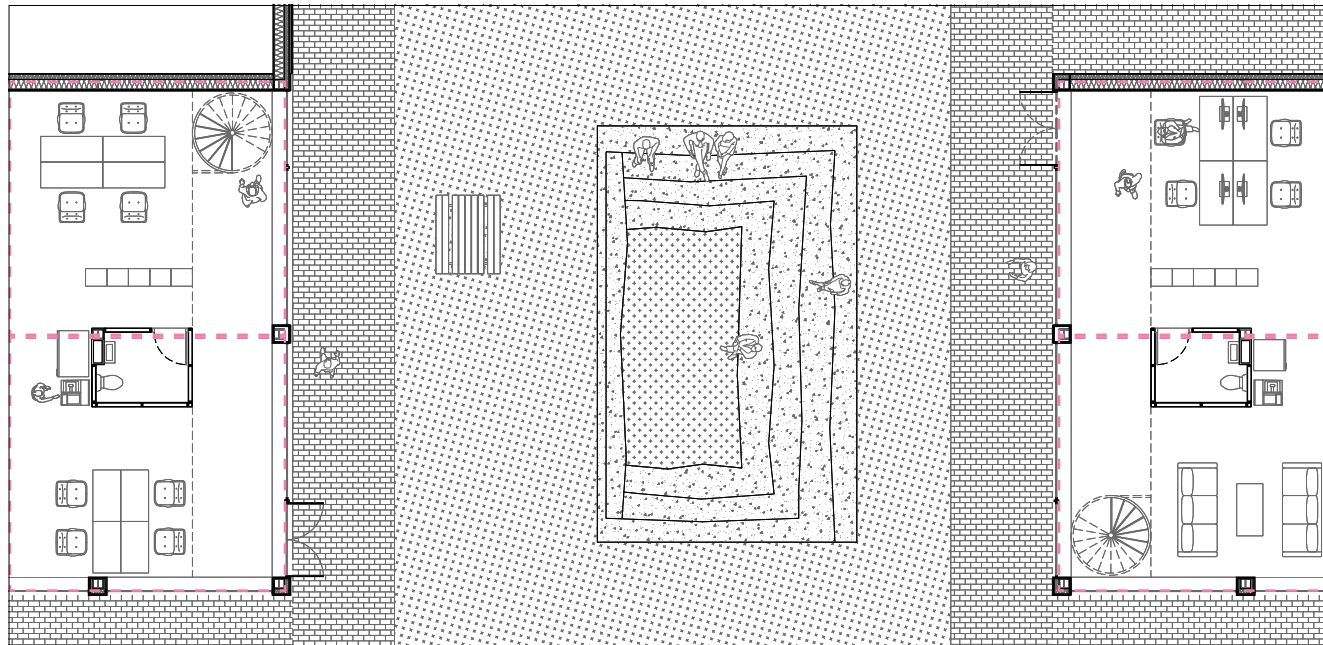
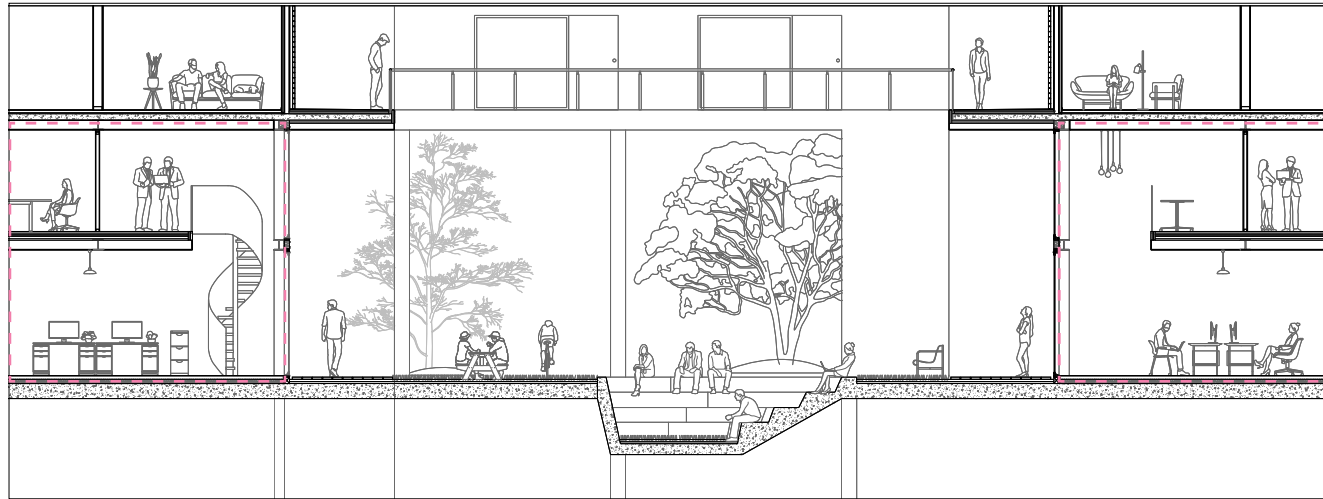

detailing

GREEN FACADE

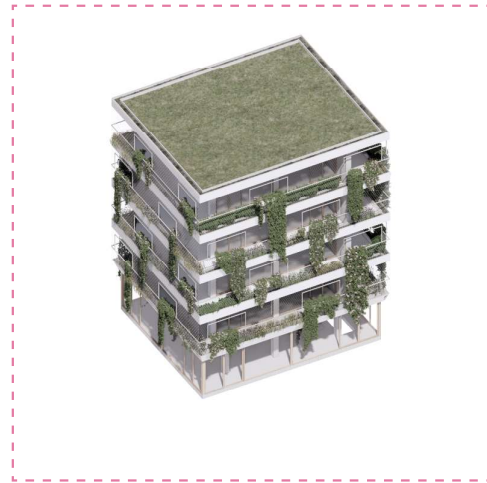

1:20 ENVELOPE FRAGMENT

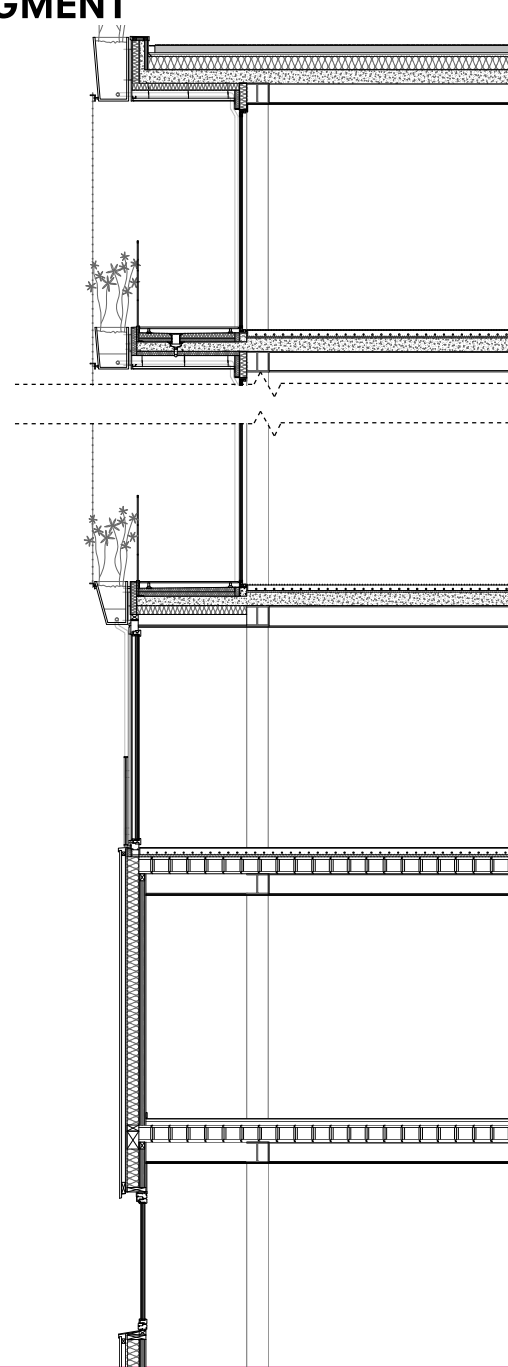
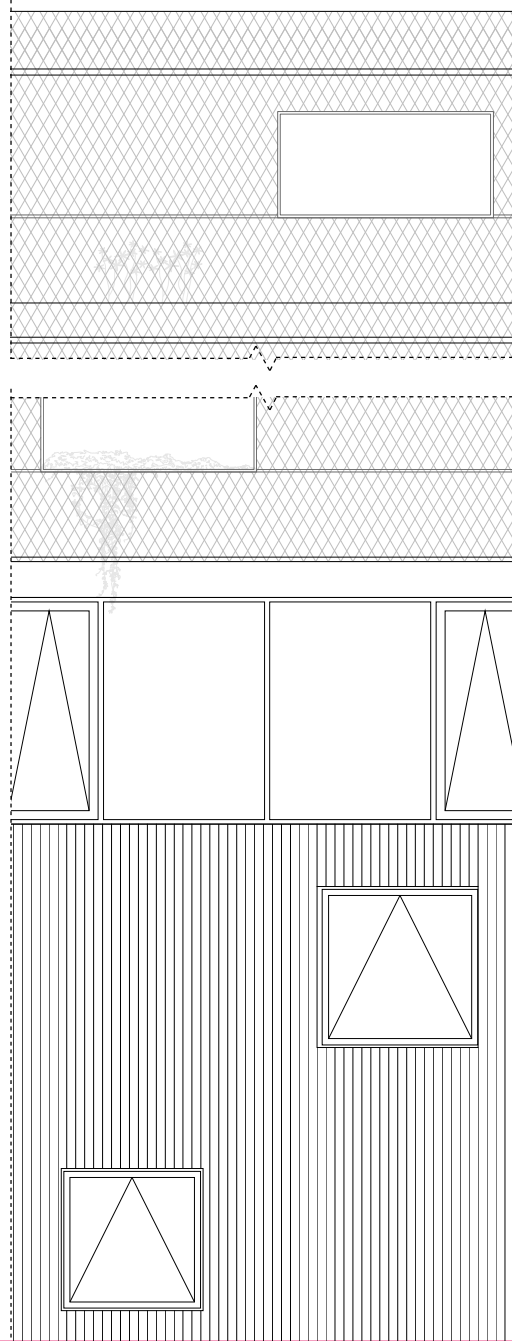

1:5 DETAIL

1. Roof construction
 - 100 mm extensive green roof
 - 15 mm filter fleece
 - 25 mm drainage layer
 - sealant layer
 - rigid foam thermal insulation
 - vapour barrier
 - concrete ceiling slab
2. steel parapet covering

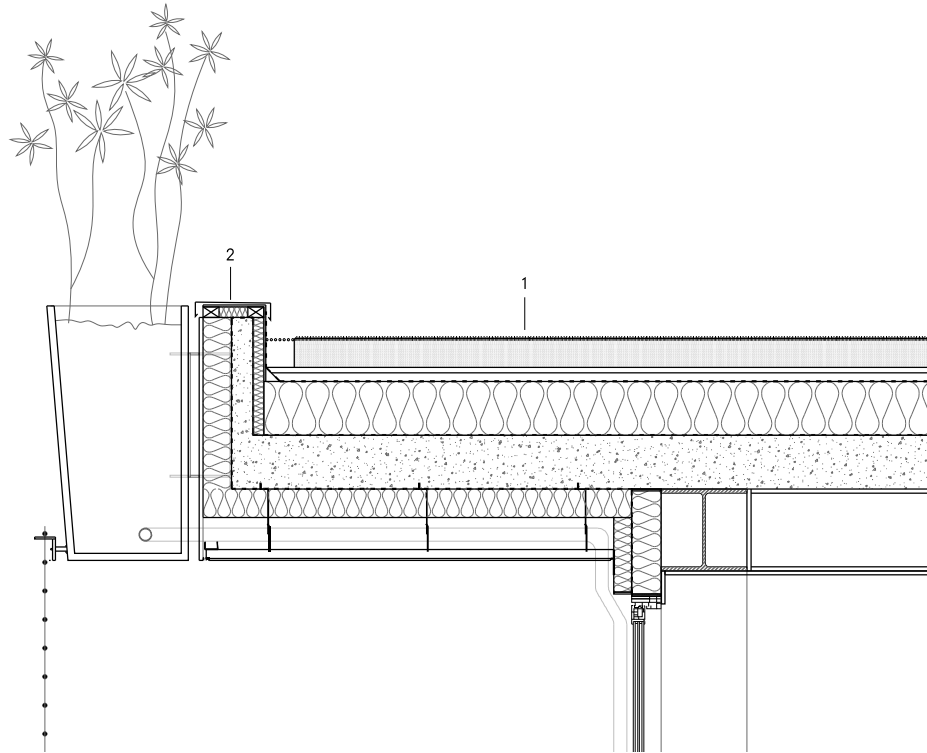

1:5 DETAIL

1. Balcony construction
 - heart pine floor boards
 - plastic raised floor support
 - XPS thermal insulation
 - sealant layer
 - PIR thermal insulation
 - vapour barrier
 - concrete ceiling slab
2. Balcony sliding door: tripple glazing
3. Aluminium sheed metal plant box
4. Dainage layer

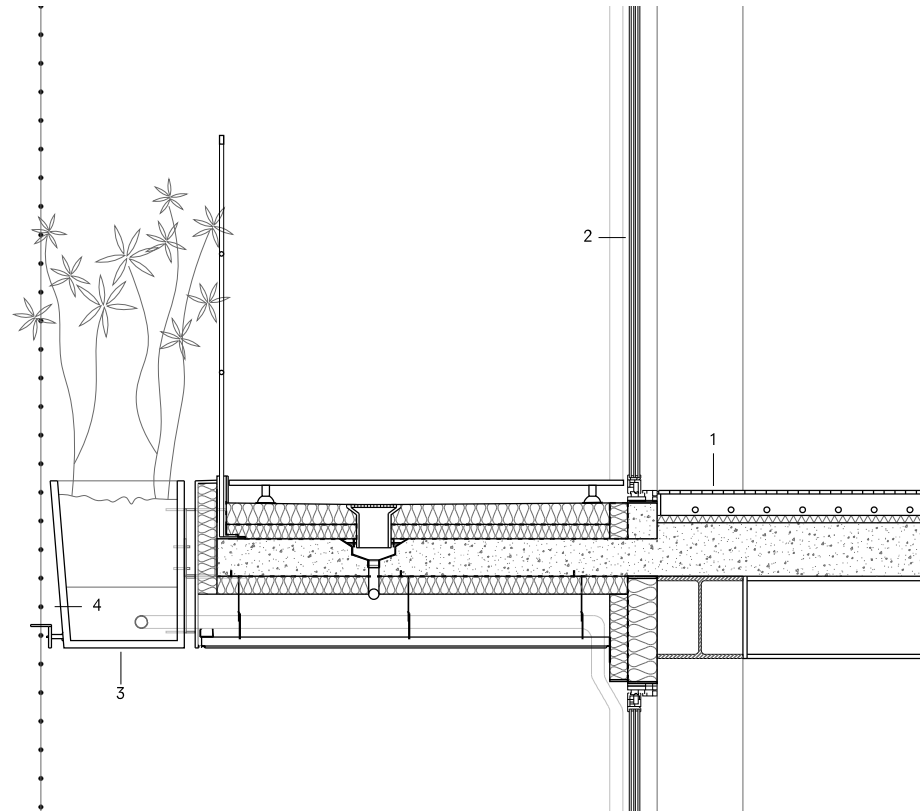

1:5 DETAIL

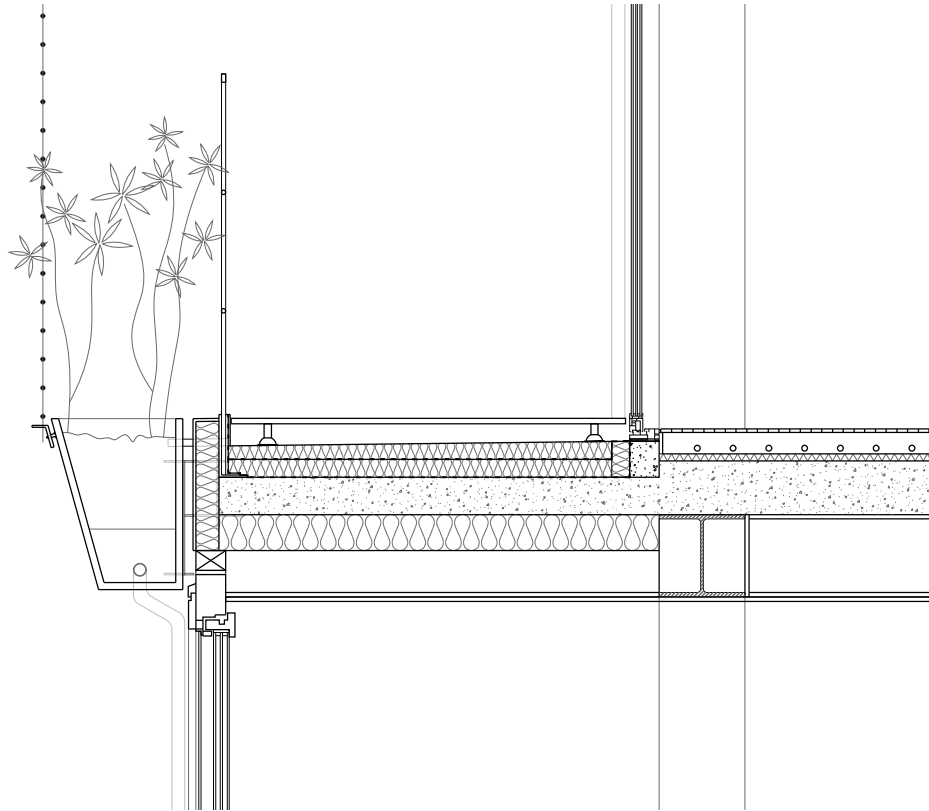

1:5 DETAIL

1. Floor construction
 - floor covering parquet flooring
 - dry top floor with underfloor heating
 - impact sound insulation
 - timber box element floor
 - steel beams
2. Balcony door: triple glazing
3. Balcony balustrade

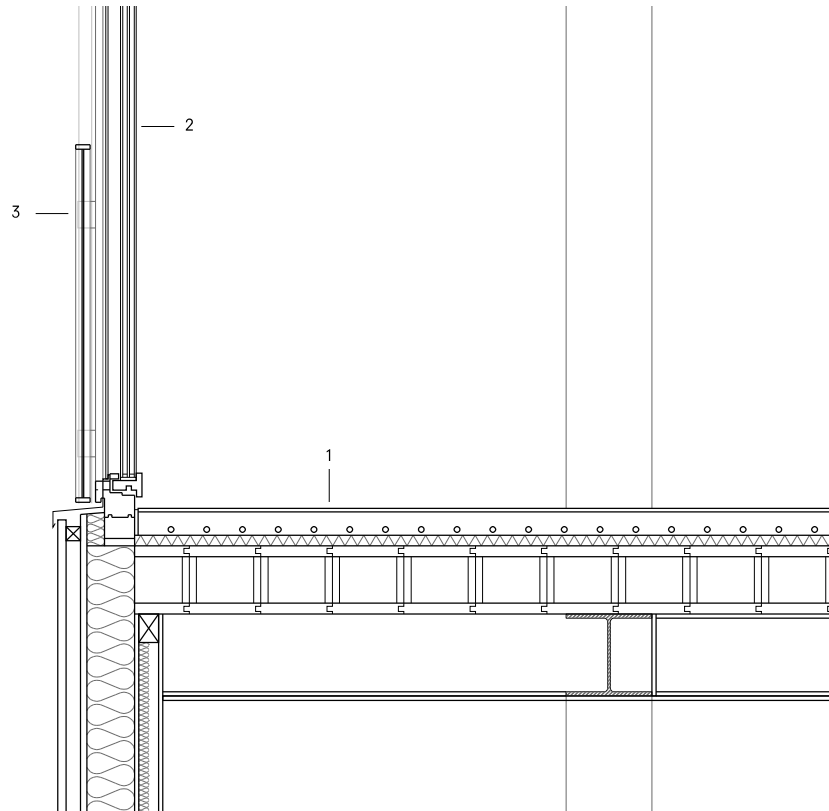

1:5 DETAIL

1. Wall construction
 - wood cladding panel
 - battens, ventilated cavity
 - rock-wool insulation
 - soft-board (airtight membrane)
 - thermal insulation, frame
 - vapour check
 - sound insulation
 - battens (space for services)
 - wood-cement particleboard

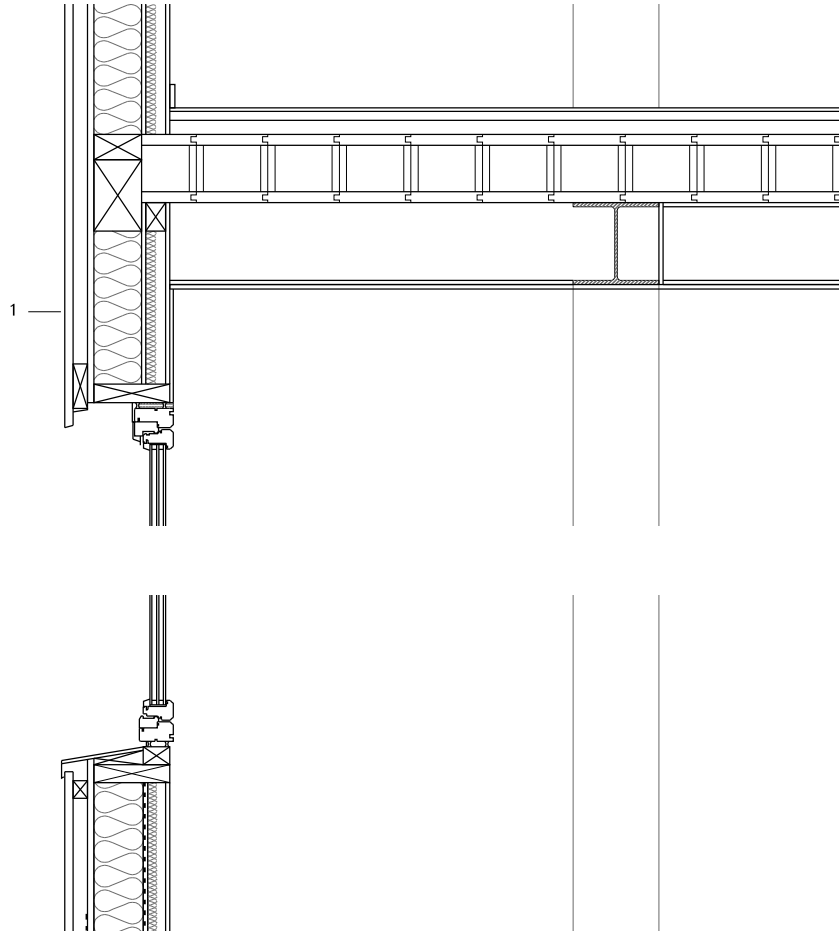

CLIMATE

NATURAL COOLING EFFECT



Green platform
/less heat absorbed
/lower the surface
temperature

Green walls and green roof
/reduce heat transmission
into buildings

Small green spaces
/reduce air temperature
/reduce surface temperature
via shade provision

Increased albedo
/more heat reflected
/more cooling from
evaporation

VENTILATION

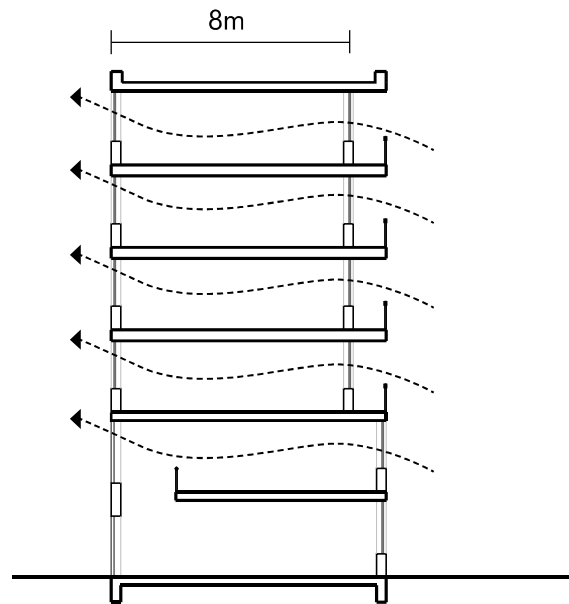
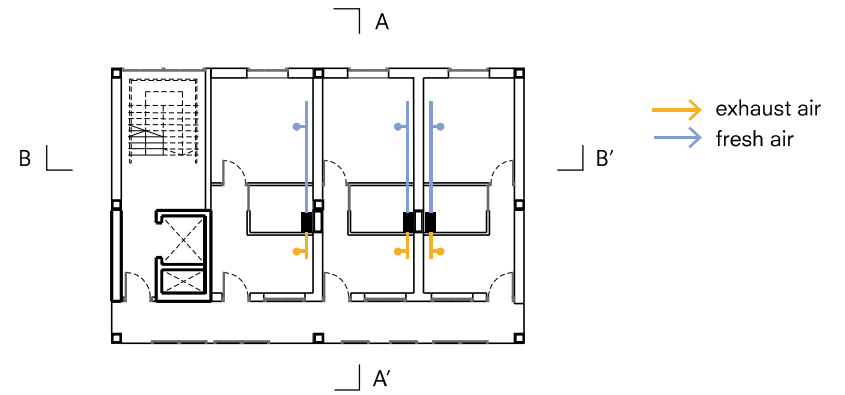

natural ventilation

section AA'

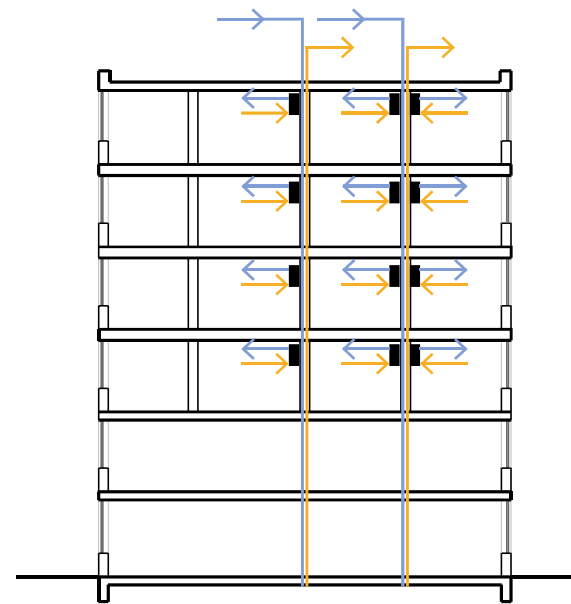

mechanical ventilation - decentralized AHU

section BB'

DISTRICT HEATING

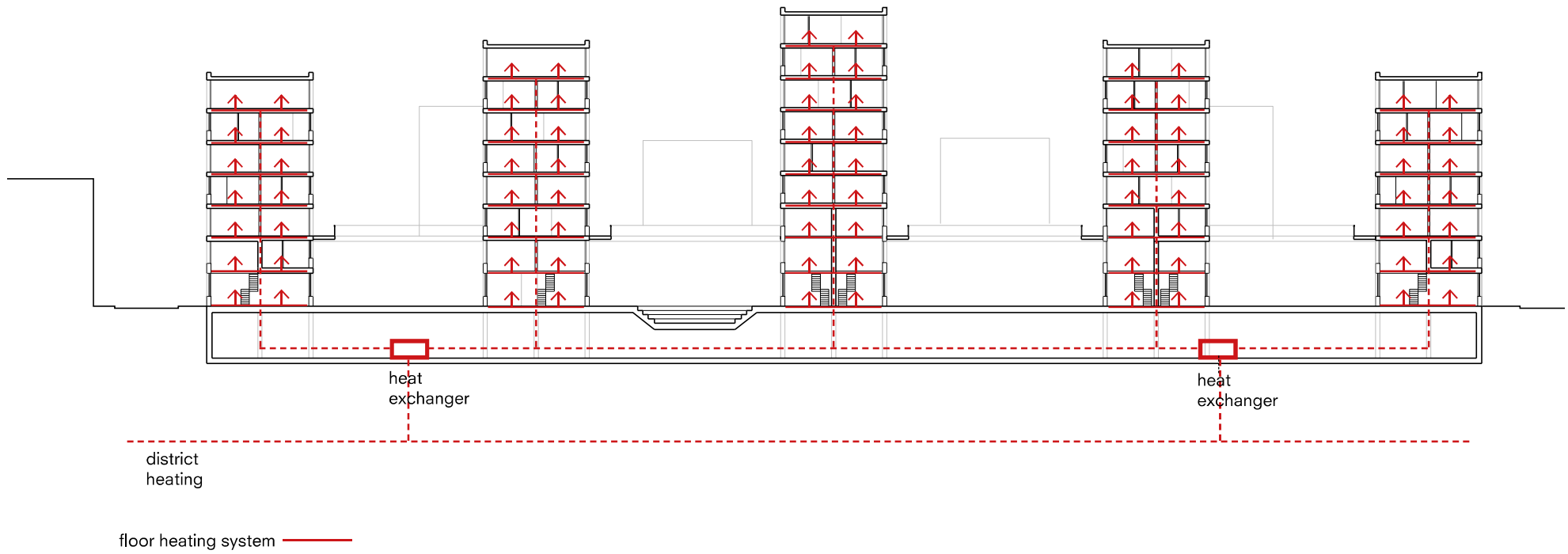

INTRODUCTION

SUMMARY OF THE RESEARCH

DESIGN BRIEF

SYSTEM CONCEPT

DESIGN PROPOSAL

CONCLUSION

REFLECTION

THANK YOU

