

A 3D cutaway rendering of a timber joint. The image shows a vertical post and a horizontal beam meeting at a corner. The joint is reinforced with several metal brackets, some of which are bolted to the wood. The wood is light-colored with a visible grain. The background is a light beige color.

# Adaptable load-bearing timber structures

Using a scenario based design methodology

Myrthe Peet  
4657403

Mentors:  
Dr. Stijn Brancart  
Ir.arch. Gilbert Koskamp

P5  
June 30 2023

Delegate Board of examiners:  
Silvia Naldini

# Adaptation

“The process of changing to suit different uses or conditions of a particular environment”



on

to suit different uses or  
for a particular environment”



for a partic



(Cambridge University Press, n.d.)



Vertrek	Naar/Opmmerkingen	Spoor/Trein	
10:43	Schiphol Airport → Rijdt niet	-	Intercity staking
10:47	Venlo Rijdt niet	-	Intercity staking
11:13	Schiphol Airport → Rijdt niet	-	Intercity staking
11:17	Venlo Rijdt niet	-	Intercity staking
11:43	Schiphol Airport → Rijdt niet	-	Intercity staking

Eindhoven - Roermond; 's-Hertogenbosch - Tilburg 2/2  
Staking: geen treinen rond Eindhoven C., Roosendaal, 's-Hertogenbosch en Breda dit duurt tot ongeveer do. 1 sep 02:00 uur.

### Building performance life cycle

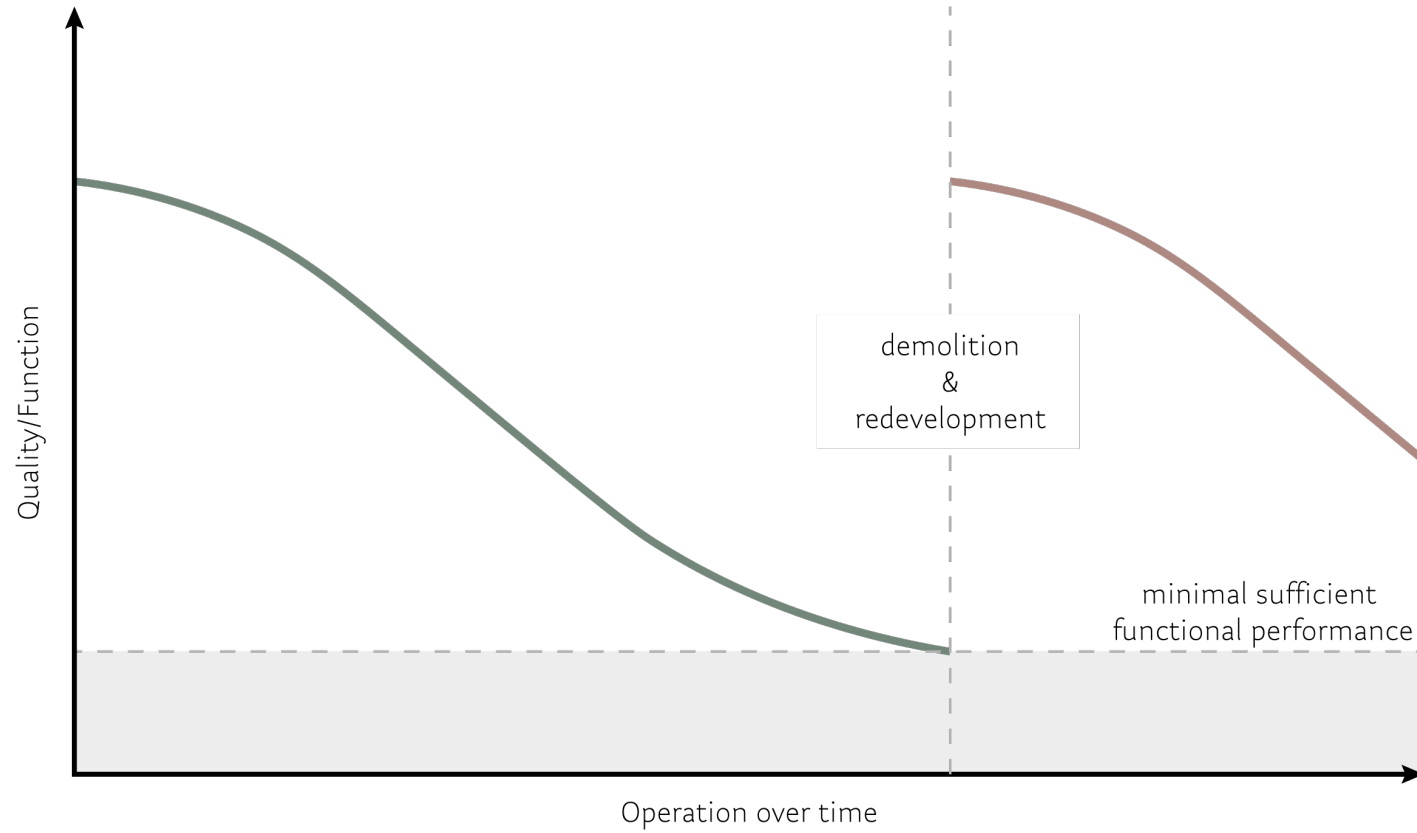

(Englund, Van Acker, & Rapp, 2023)



1 million





### Building performance life cycle

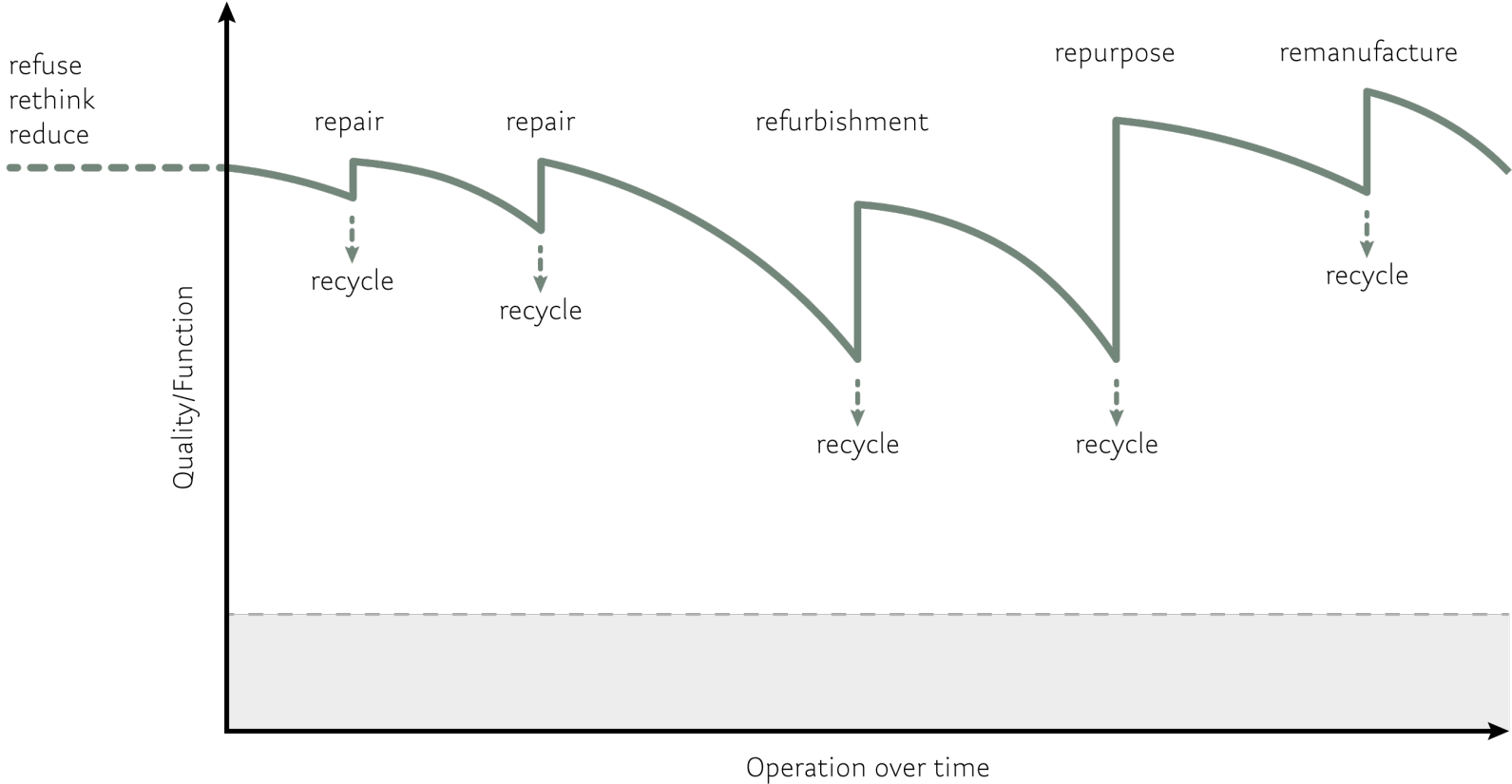

(Englund, Van Acker, & Rapp, 2023)

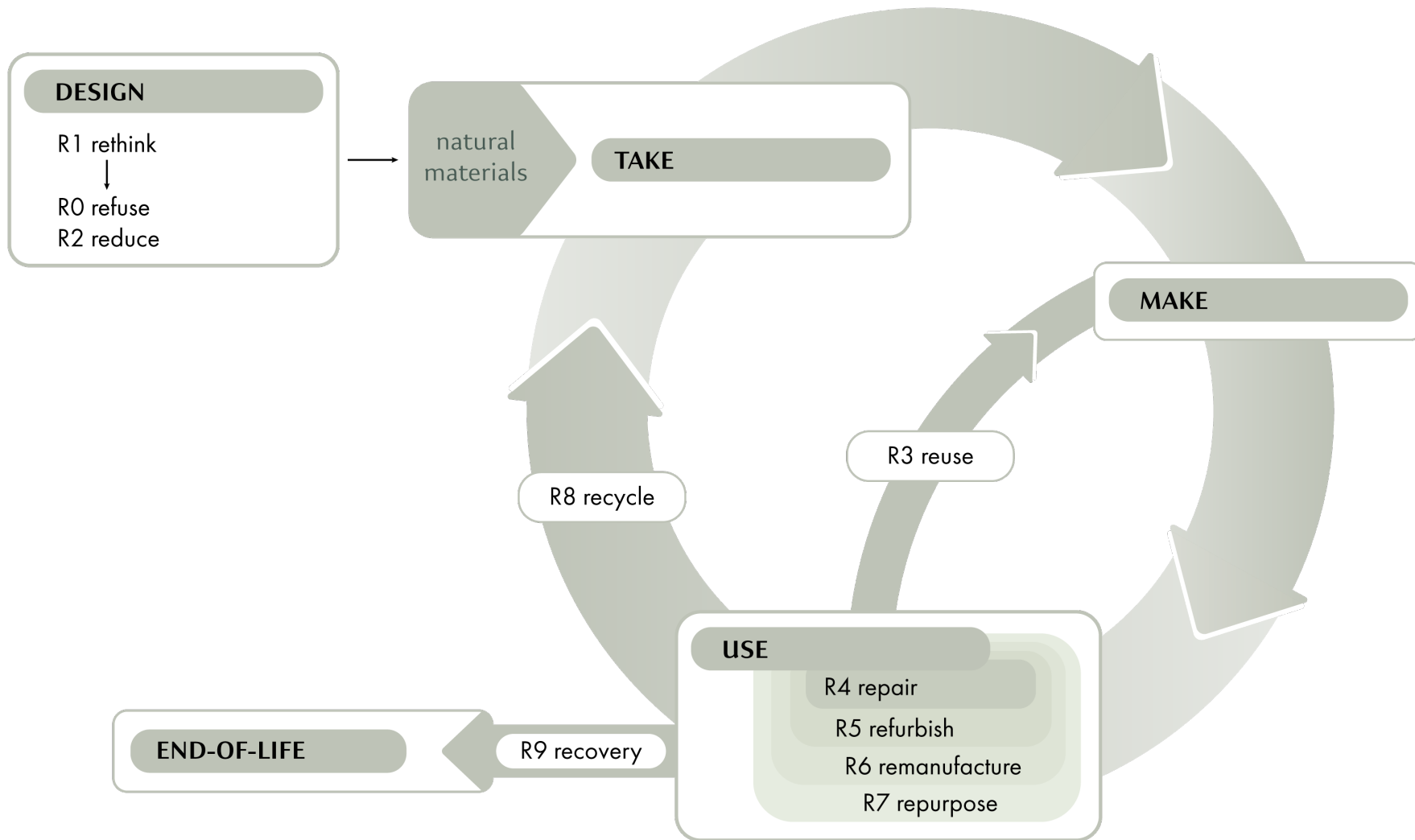

# Objectives

Prevent premature demolition

Minimize the impact of material use

Develop an adaptable structural system

How can the life span of mid-rise buildings be extended by developing an adaptable hardwood timber structure through scenario based design?

How can the life span of mid-rise buildings be extended by developing an adaptable hardwood timber structure through scenario based design?



How can the life span of mid-rise buildings be extended by developing an adaptable **hardwood timber** structure through scenario based design?



How can the life span of mid-rise buildings be extended by developing an adaptable hardwood timber structure through scenario based design?

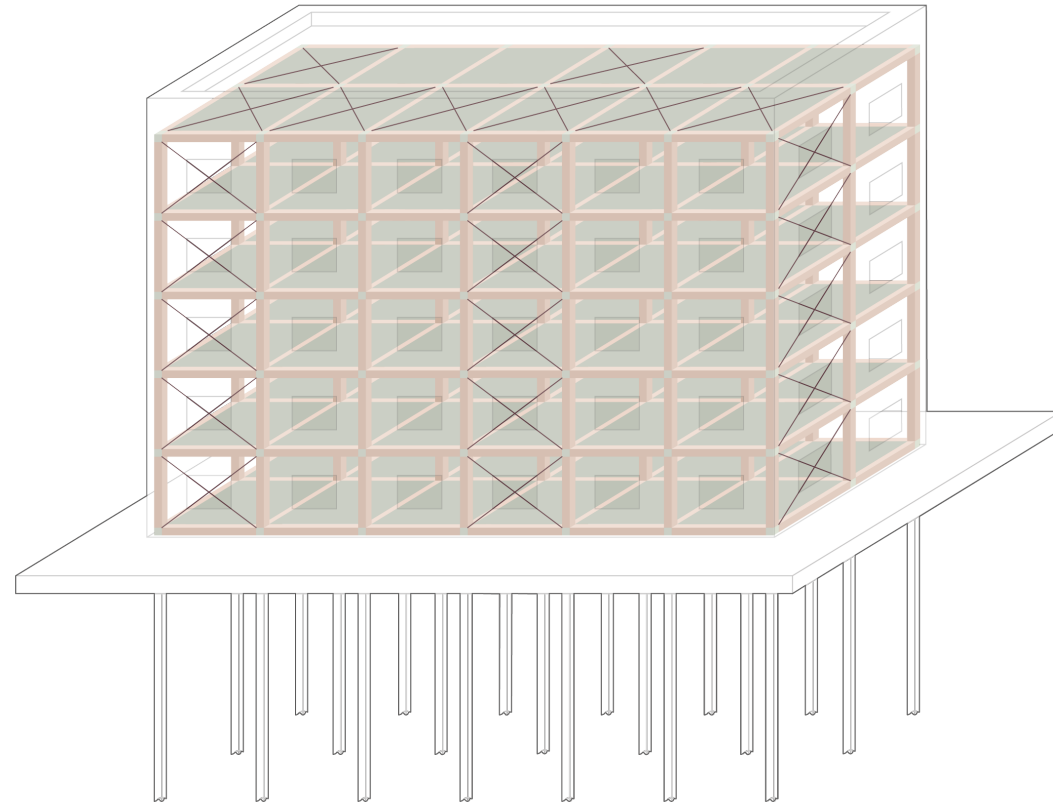

How can the life span of mid-rise buildings be extended by developing an adaptable hardwood timber structure through scenario based design?

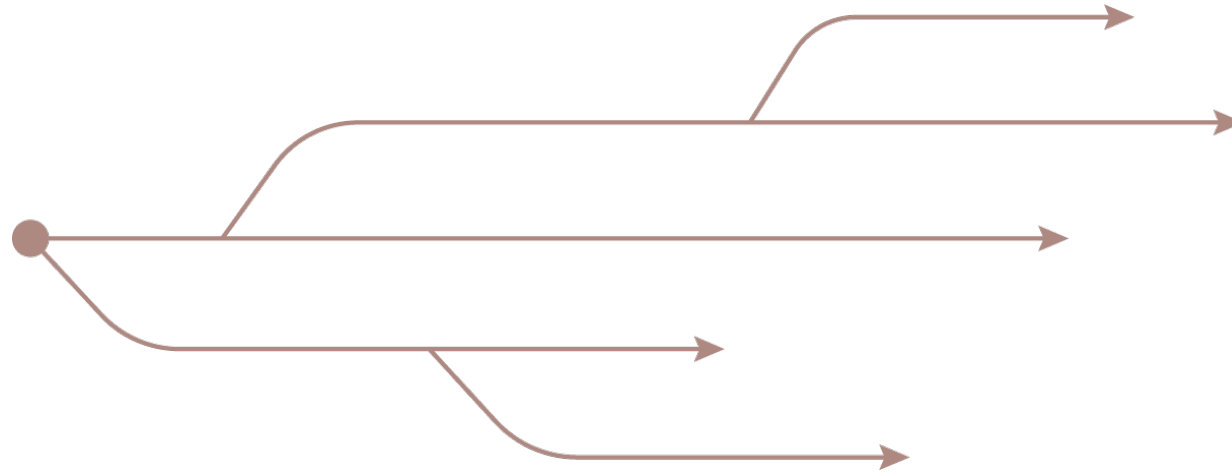





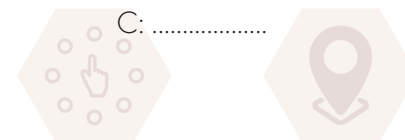
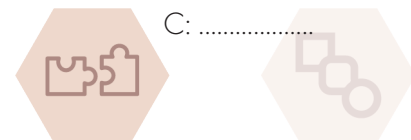
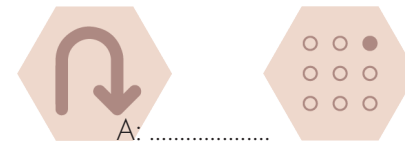
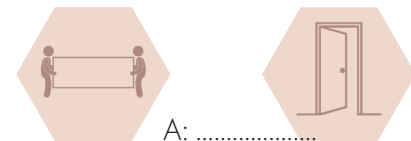
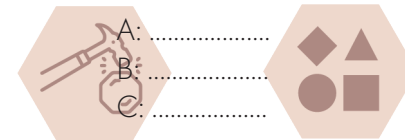
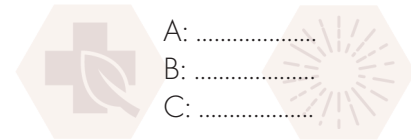
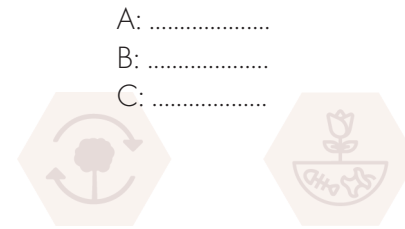
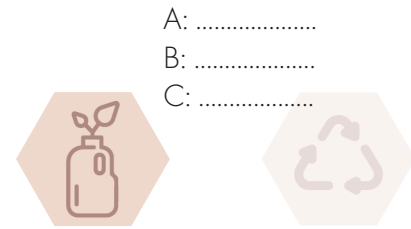

A: .....  
B: .....  
C: .....

A: .....  
B: .....  
C: .....

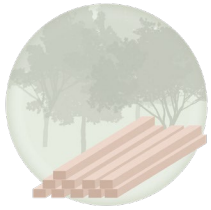

**MATERIAL**

A: .....  
B: .....  
C: .....



A: .....  
B: .....  
C: .....

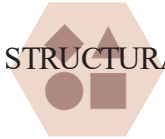
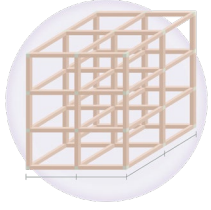
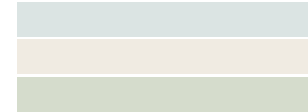
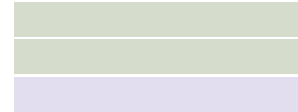

**STRUCTURAL LAYOUT**

A: .....  
B: .....  
C: .....

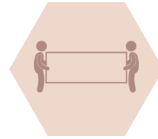

A: .....  
B: .....  
C: .....

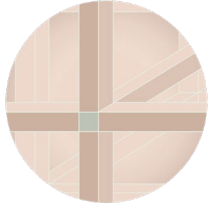
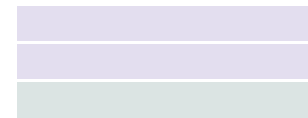
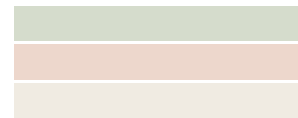

**KIT-OF-PARTS**

A: .....  
B: .....  
C: .....



A: .....  
B: .....  
C: .....

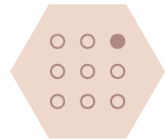
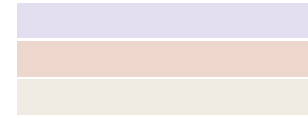
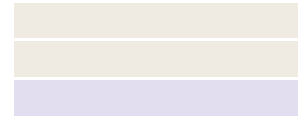

**BUILDING LAYERS**







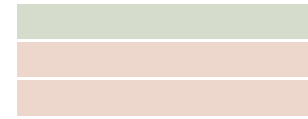
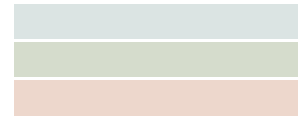

A: .....  
B: .....  
C: .....



A: .....  
B: .....  
C: .....



**CONSTRUCTION PROCESS**

	REUSABLE
	<ul style="list-style-type: none"> <li>Catalog of building components</li> <li>Standard dimensions</li> <li>Standard connection system</li> <li>Repeating patterns</li> <li>Limited use of adhesives and plasters</li> </ul>
	DURABLE
	<ul style="list-style-type: none"> <li>Long life span material</li> <li>Surface treatment</li> <li>Additional building layers covering the structure</li> <li>Minimal amount of holes in components</li> </ul>
	SIMPLE
	<ul style="list-style-type: none"> <li>Minimal unique parts</li> <li>Costs little time to construct</li> <li>Minimal steps in assembly</li> <li>Minimal experience or training needed</li> <li>Repeating patterns</li> <li>Standard dimensions</li> </ul>
	MANAGEABLE
	<ul style="list-style-type: none"> <li>Small dimensions</li> <li>Light weight</li> <li>Minimal mechanic aid needed</li> <li>Minimal amount of people needed</li> </ul>
	ACCESSIBLE
	<ul style="list-style-type: none"> <li>Minimal additional building layers covering the structure/connection node</li> <li>Additional building layers are removable</li> <li>Visible connection system</li> <li>More tolerance around components and connection node</li> </ul>
	REVERSIBLE
	<ul style="list-style-type: none"> <li>Connection node can be demounted</li> </ul>
	INDEPENDENT
	<ul style="list-style-type: none"> <li>Components are individually connected</li> <li>Little disturbance of other components when handling one component</li> </ul>
	COMPATIBLE
	<ul style="list-style-type: none"> <li>Multi-functionality of single component</li> <li>Minimal different connection types</li> <li>Standard dimensions</li> <li>Repeating patterns</li> </ul>

## Evaluation method



Analysis existing systems

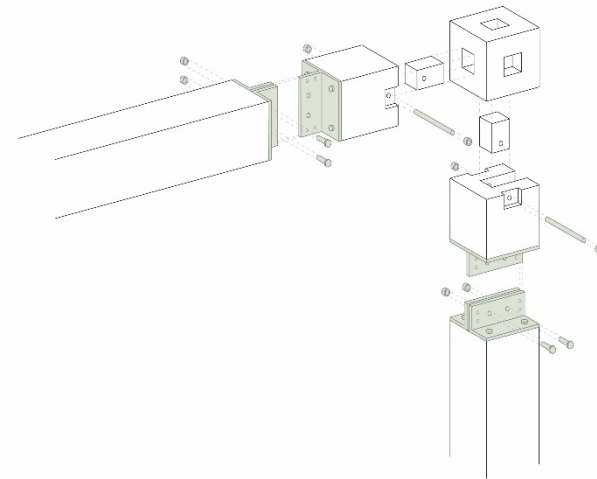

Design proposal

# Euregon office - Augsburg



(Merz, Niemann, & Torno, 2021)

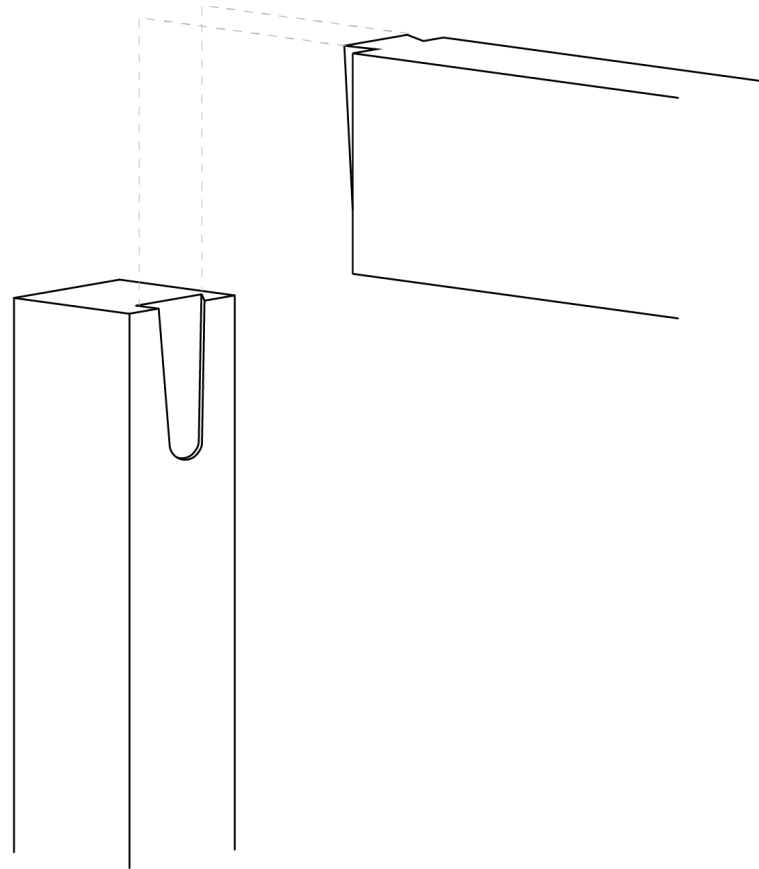
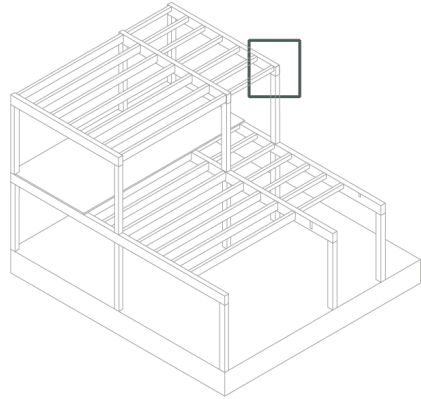

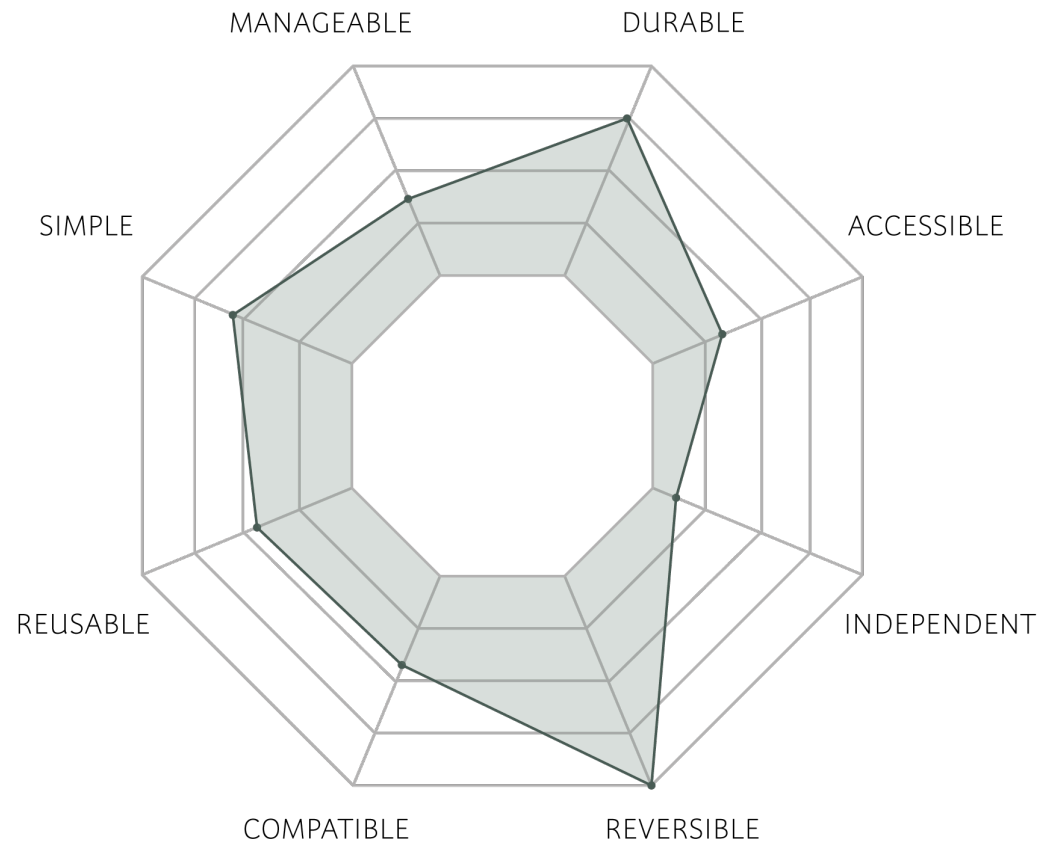



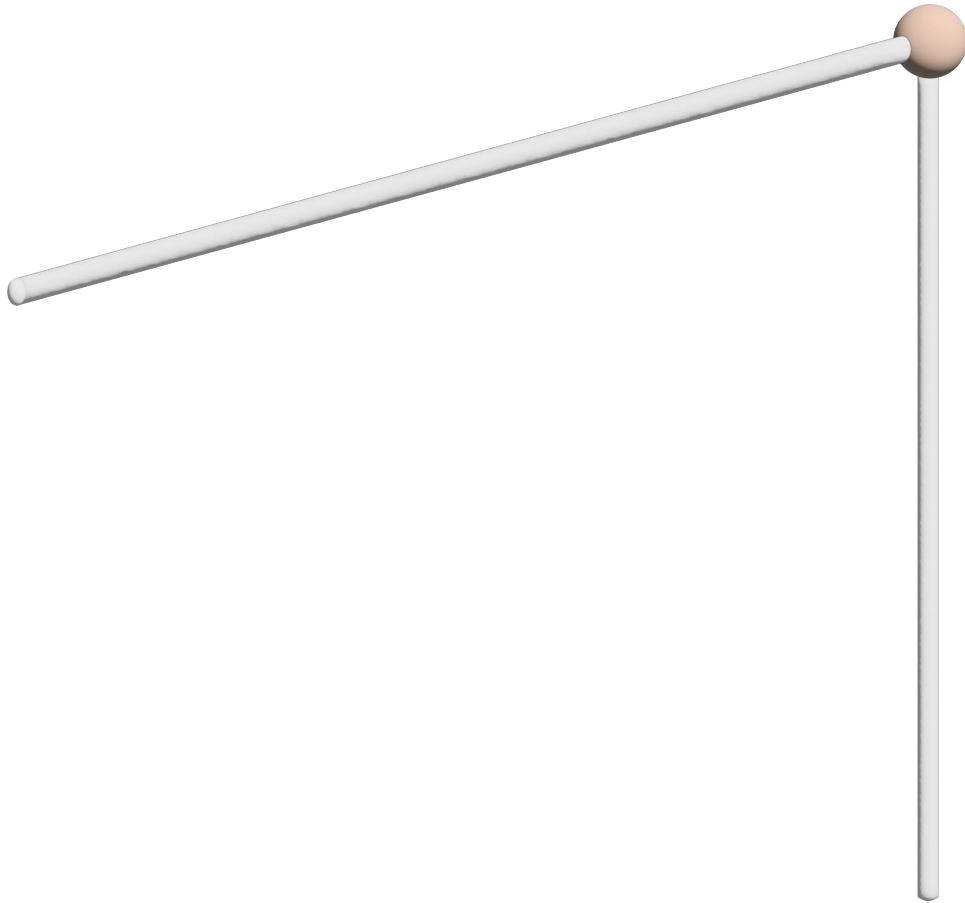

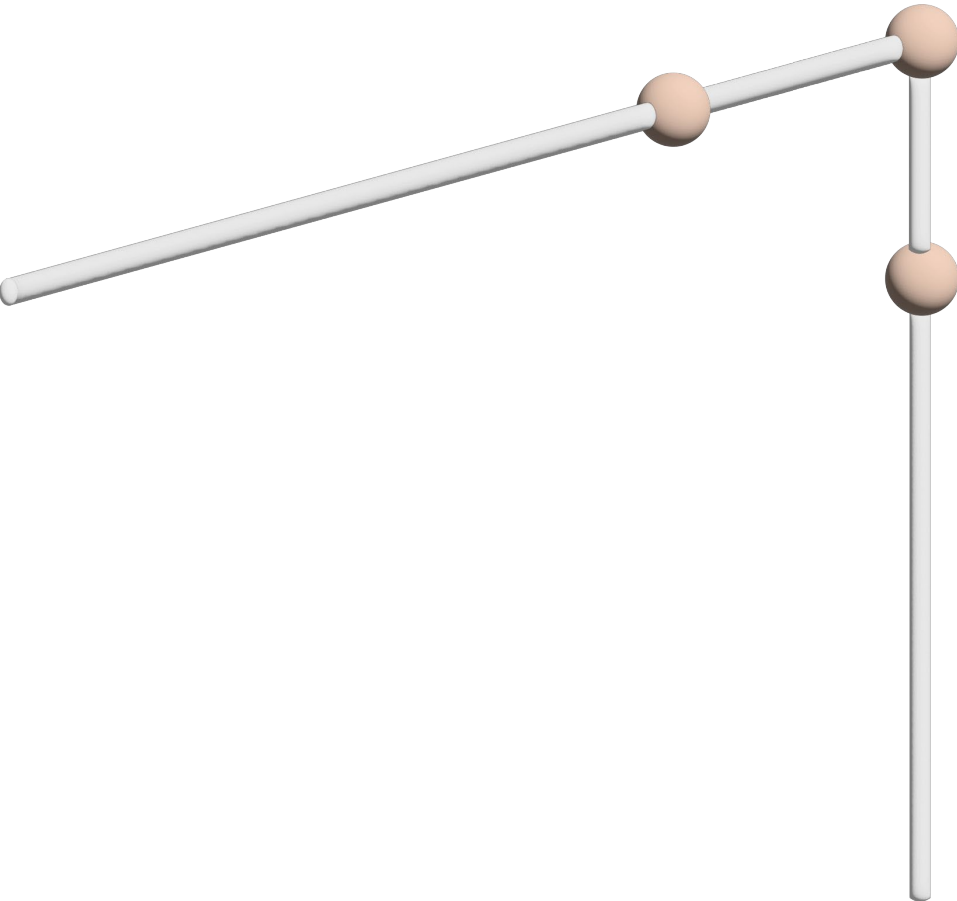

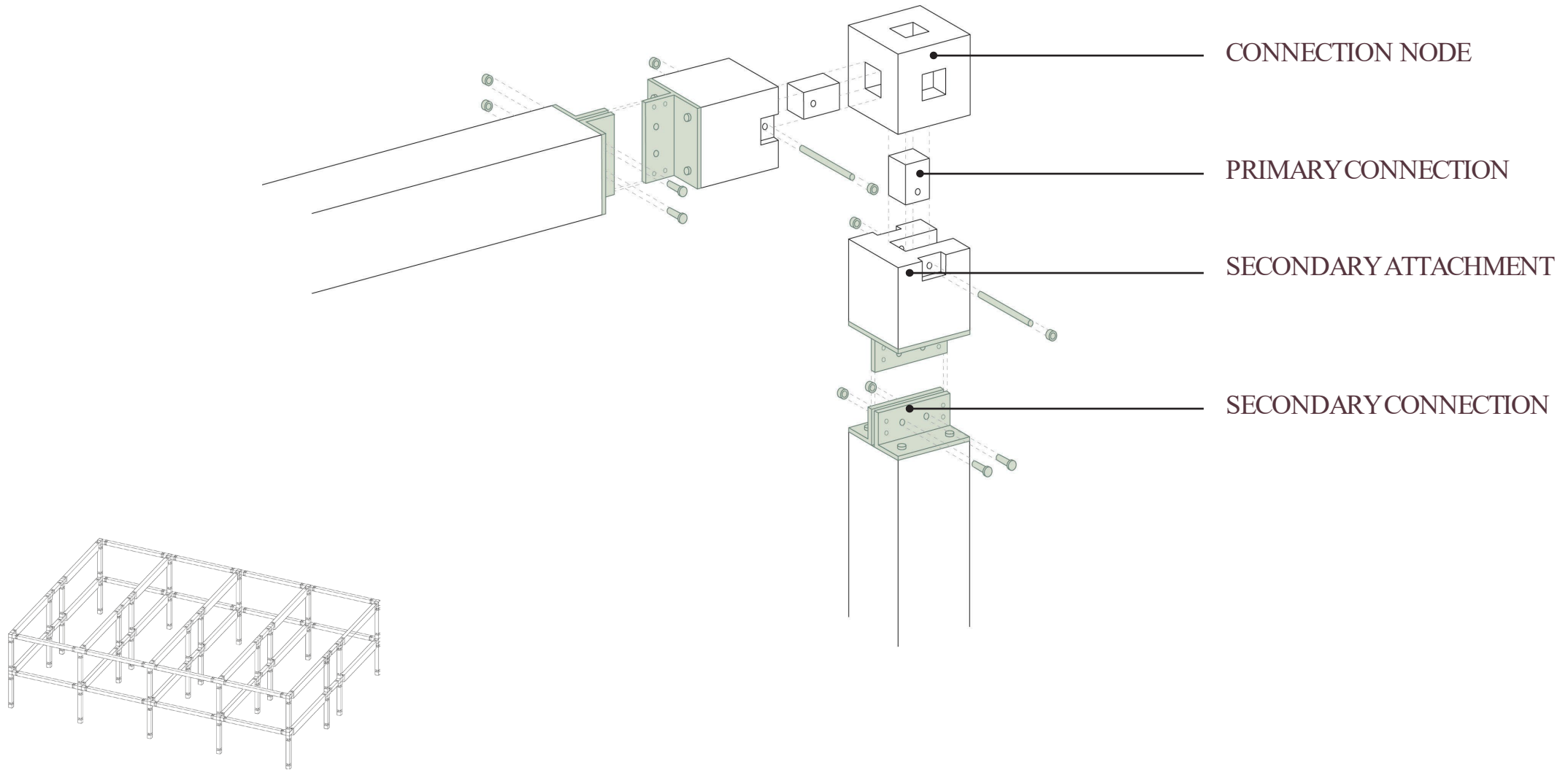

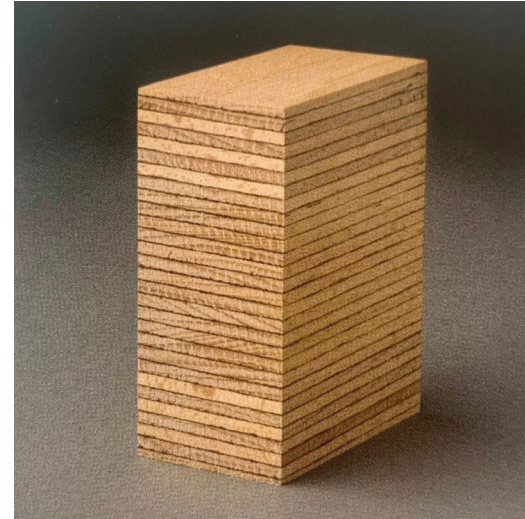
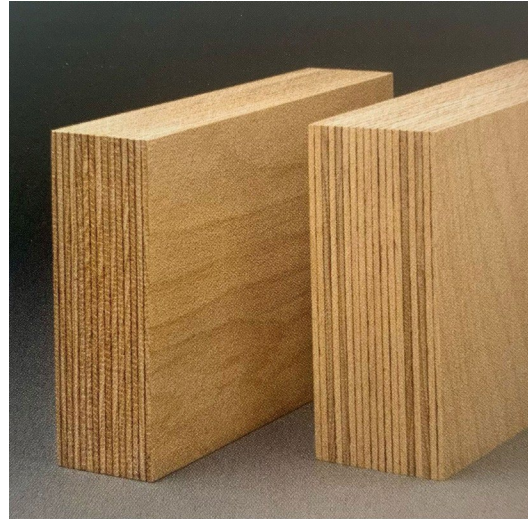

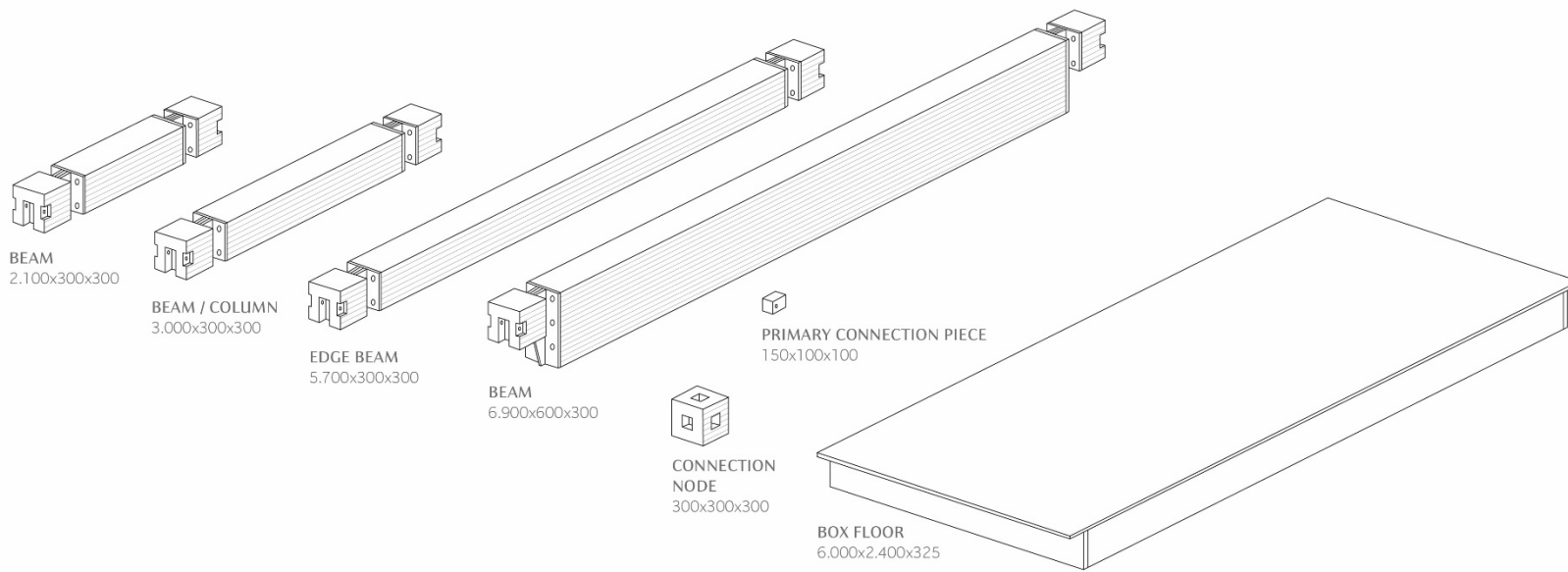

# Case study



2016



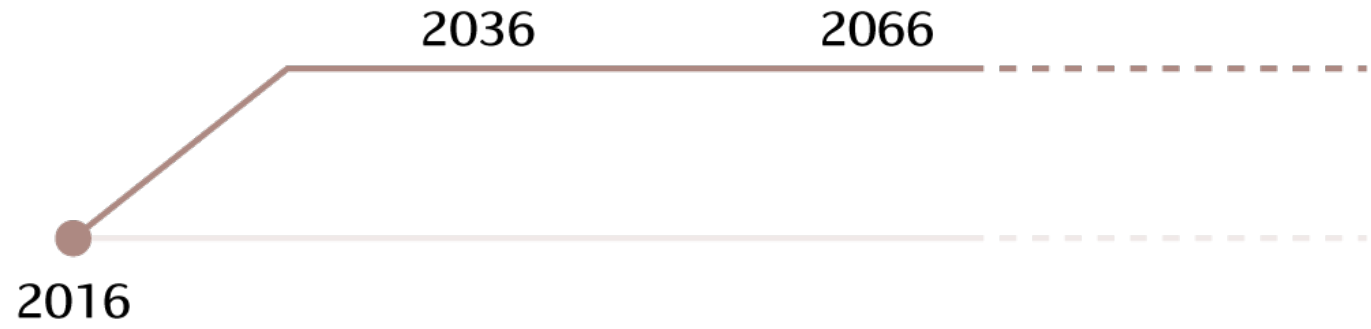



## Original building



Material/Building product

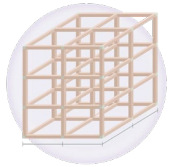

Structural layout



Architectural design

## Integration of adaptable system

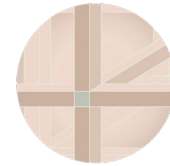

Connection principle



Relation to other building layers



Construction process

# 2016

Initial construction



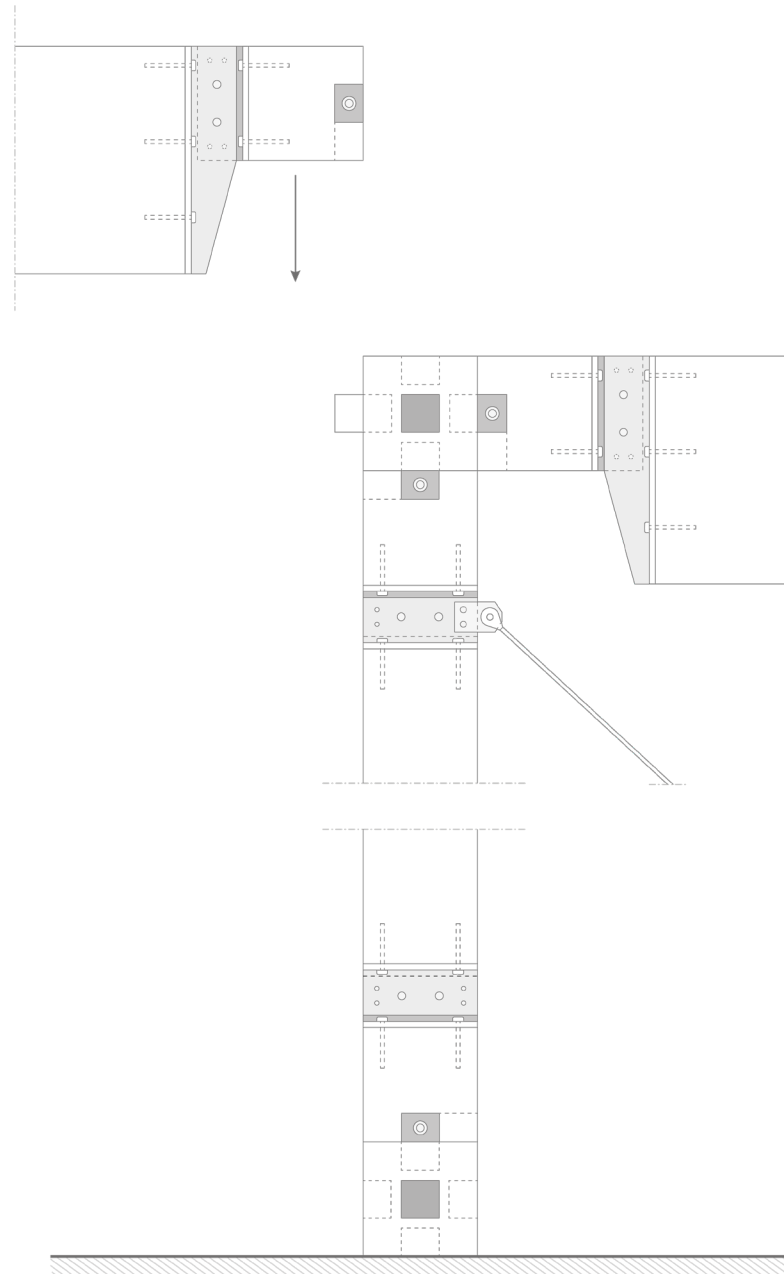
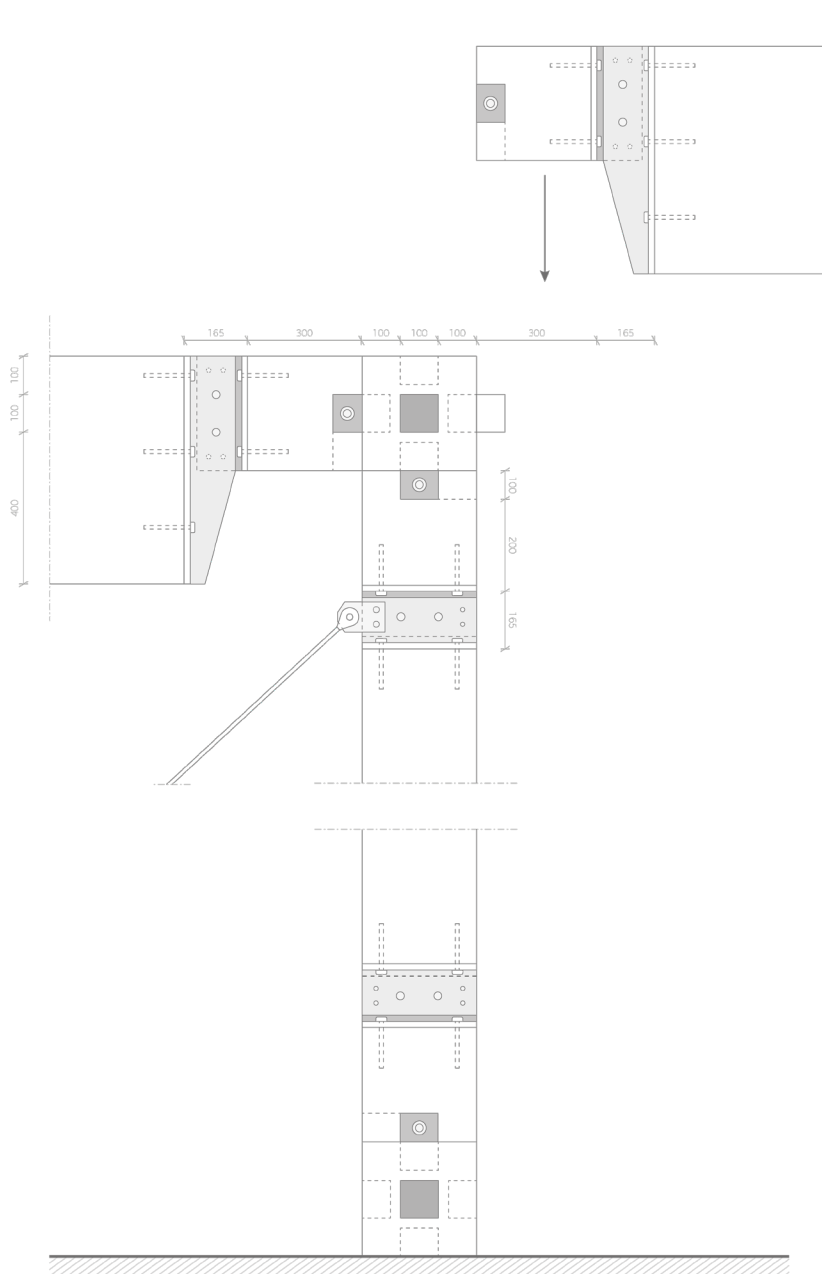

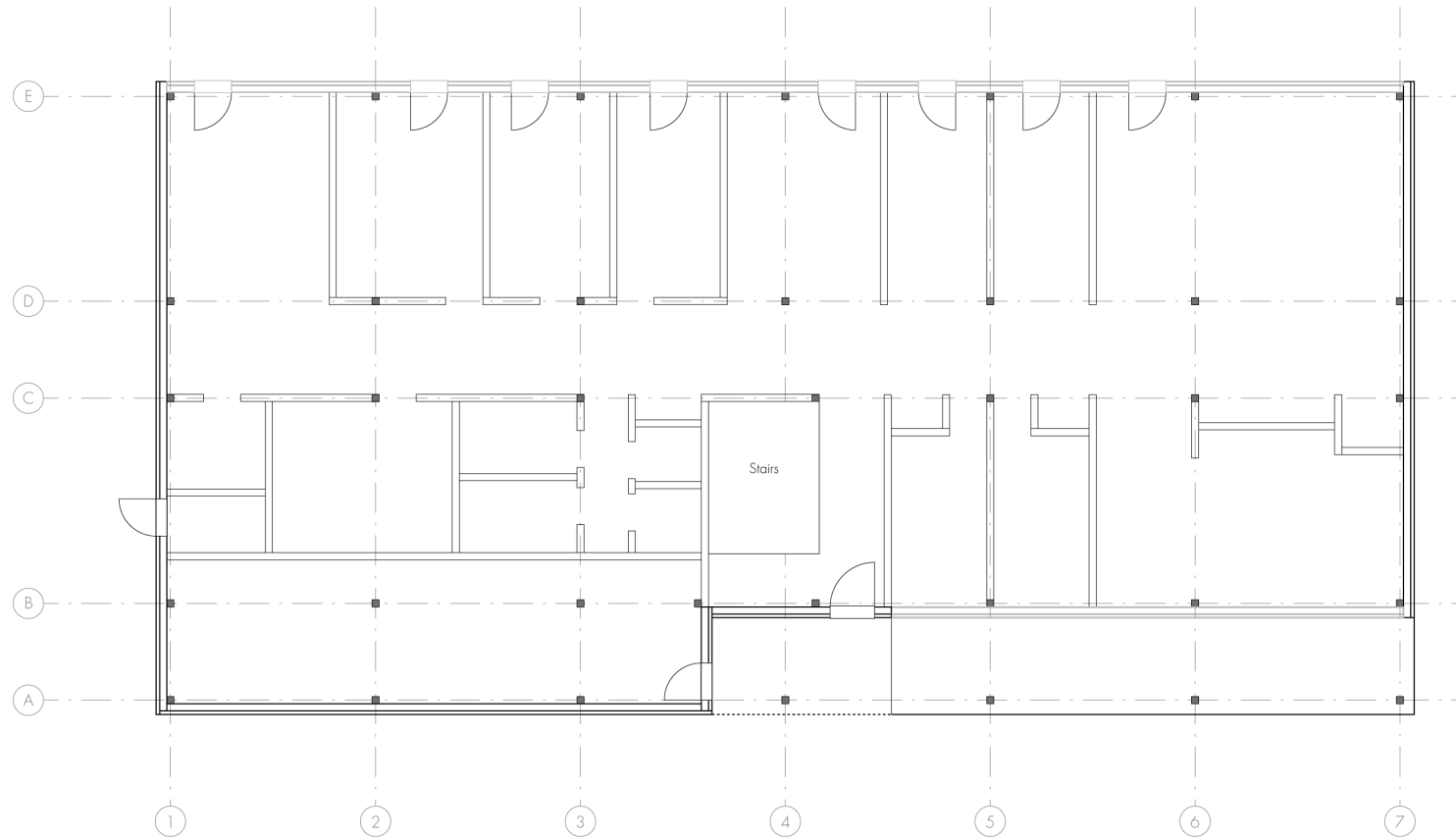

# Initial construction

## Benefits

Fast construction  
Standard connection system

## Shortcomings

Heavy building components  
Experience required  
Moisture  
Fire safety

# 2036

## Transformation





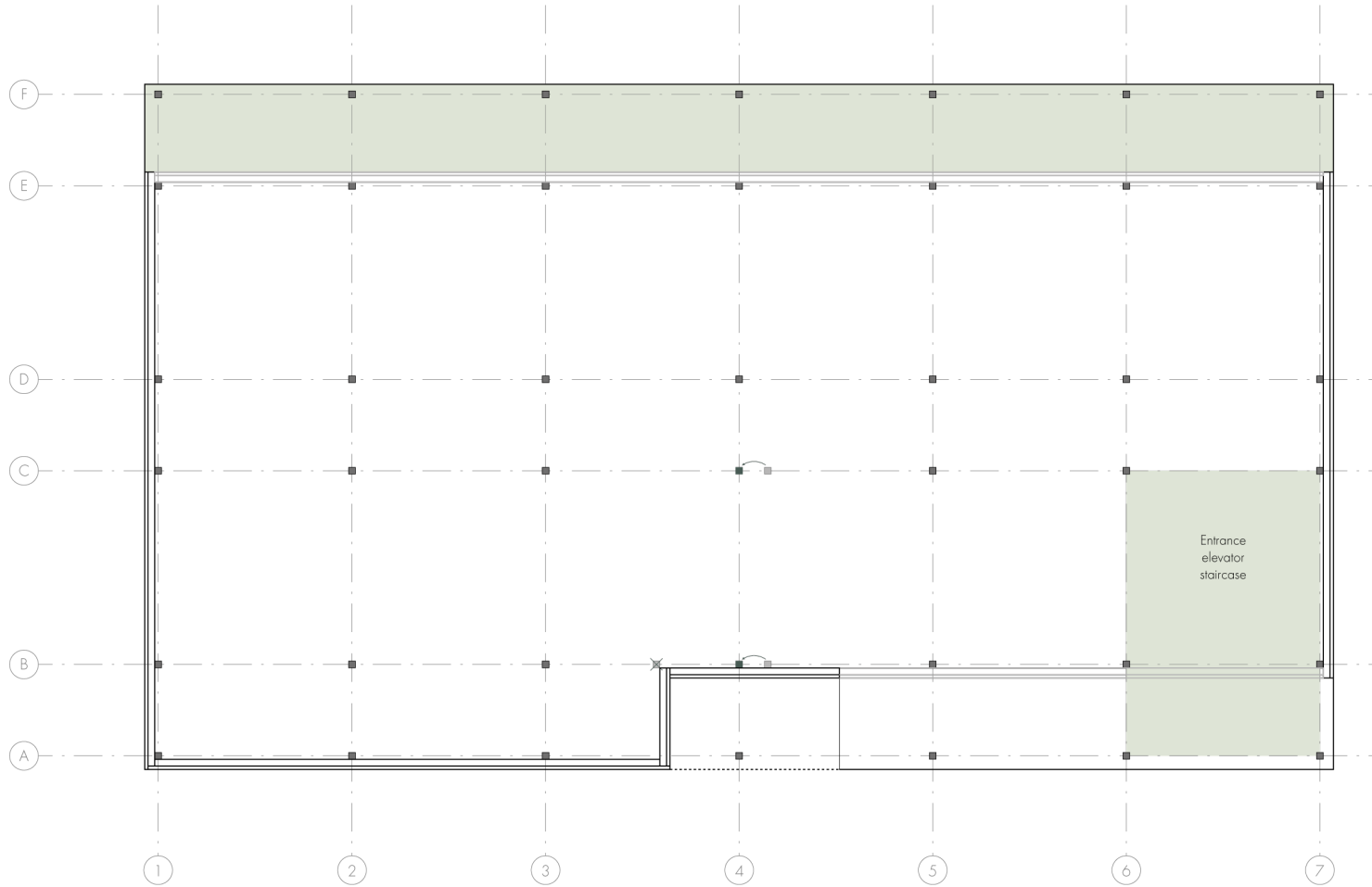

Sub-scenarios:

- Adding balconies
- Moving staircase

# Subscenario - Adding balconies

## Benefits

Standard connection system  
Visible connection node

## Shortcomings

Dependency on adaptability other building layers  
Changing load case

# Subscenario - Moving staircase

## Benefit

Independent flooring system

## Potential shortcoming

Handling capabilities

# 2066

Repair



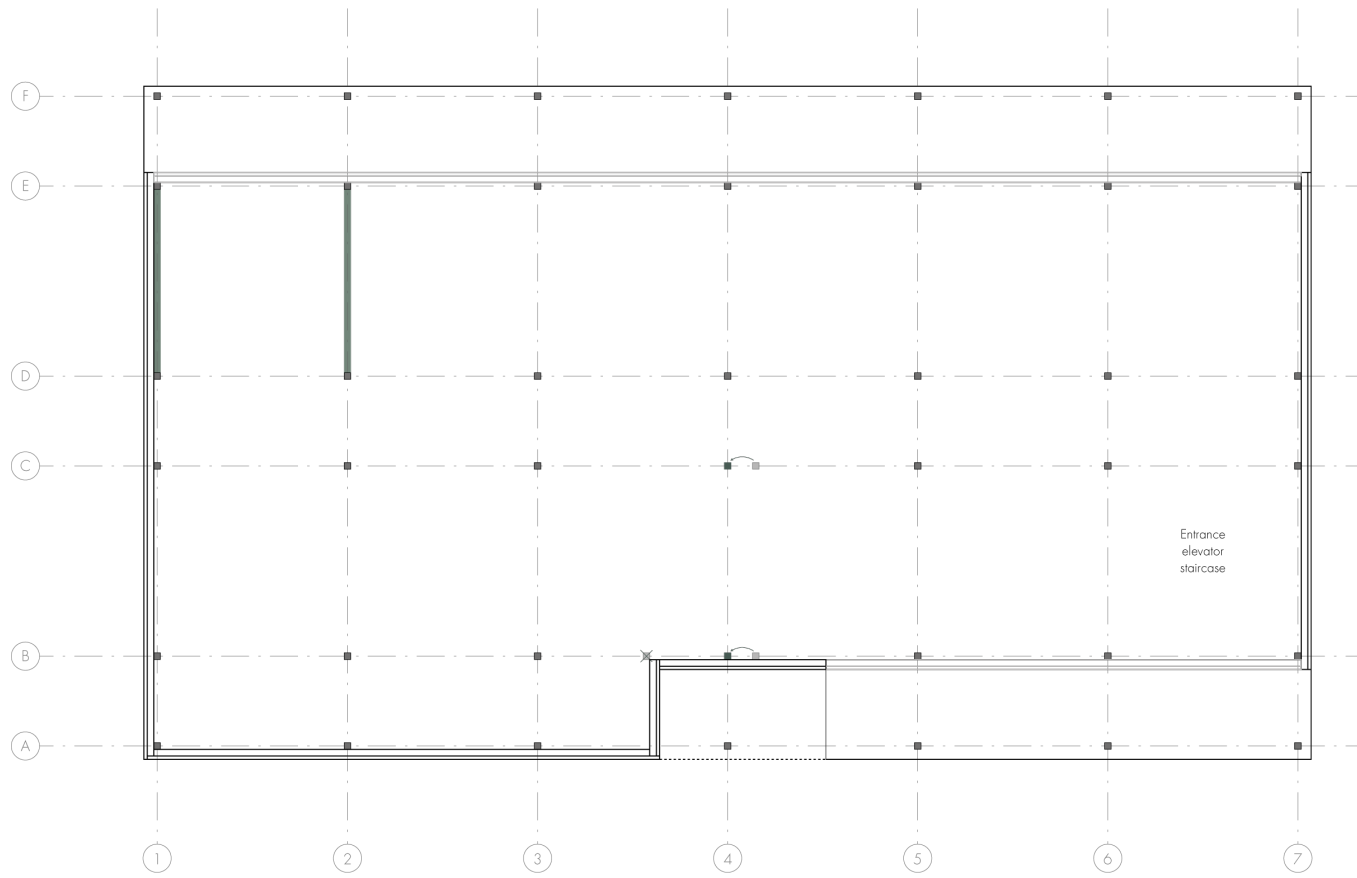

1

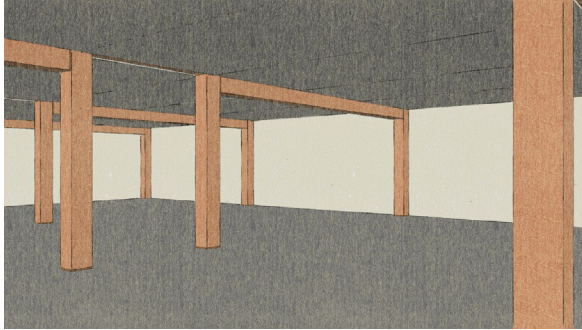

2

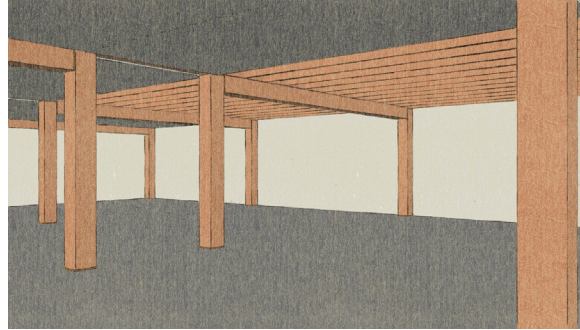

3

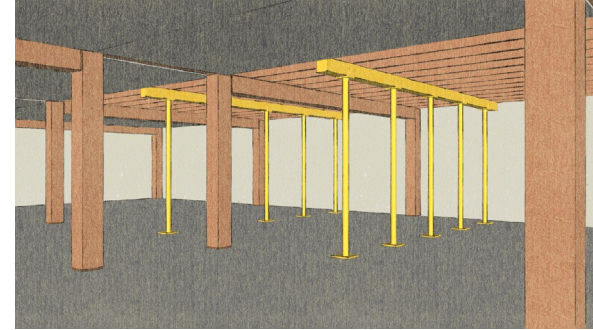

4

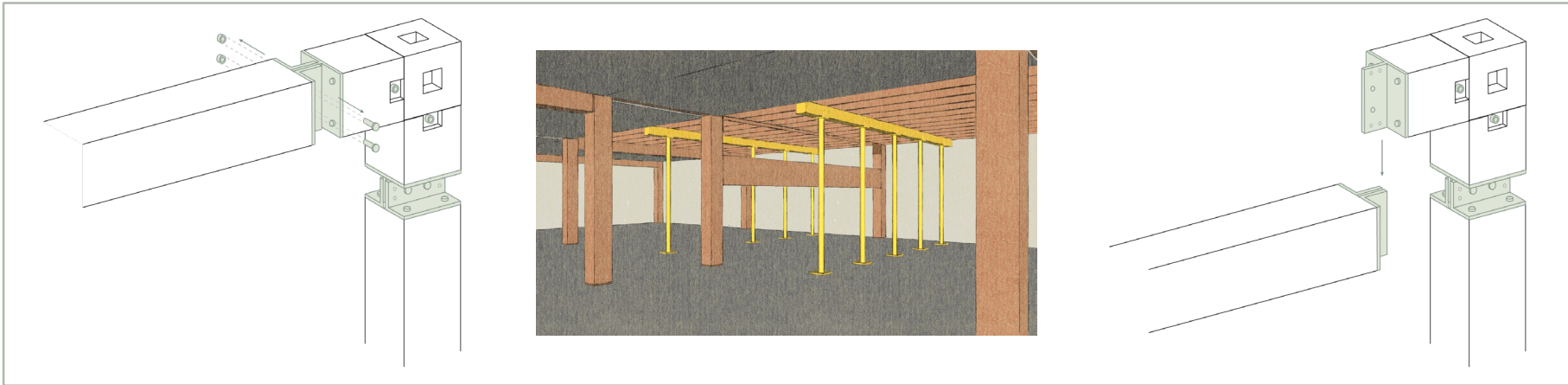

# Subscenario - Replacing beams

## Benefits

Accessible secondary connection  
Individuality components  
Standard dimensions/kit-of-parts

## **(Potential) shortcomings**

Handling capabilities  
Disturbance of tenants



# Conclusion

Consider adaptation during design phase

Dependency on adaptability of other building layers

Design proposal does not eliminate all current challenges

Lowered threshold

# Further research

Economic feasibility

Sustainability analysis

Alternative materials



Thank you,  
questions?

Myrthe Peet  
4657403

P5  
June 30 2023

51

Mentors:  
Dr. Stijn Brancart  
Ir.arch. Gilbert Koskamp

Delegate Board of examiners:  
Silvia Naldini

References:

Cambier, C., Elsen, S., Galle, W., Lanckriet, W., Poppe, J., Tavernier, I., & Vandervaeren, C. (2019). *Bouwen voor een circulaire economie: Ontwerpqualiteiten om architecten en opdrachtgevers te begeleiden en inspireren*. Vrije Universiteit Brussel.

Cambridge University Press. (n.d.). Adaptation. In *Cambridge Dictionary*. Retrieved March 23, 2023, from <https://dictionary.cambridge.org/dictionary/english/adaptation>

Englund, F., Van Acker, J., & Rapp, A. O. (2023). Performance Classification - a strategy for wooden products. *ResearchGate*, 59. Retrieved from [https://www.researchgate.net/publication/241760771\\_Performance\\_Classification\\_-\\_a\\_strategy\\_for\\_wooden\\_products](https://www.researchgate.net/publication/241760771_Performance_Classification_-_a_strategy_for_wooden_products)

Merz, K., Niemann, A., & Torno, S. (2021). *Building with Hardwood* (1st ed.). DETAIL.