

## Temperature-immune readout of an integrated optical wavelength meter based on microring resonators

Taballione, Caterina; Agbana, Tope; Vdovin, Gleb; Hoekman, Marcel; Wevers, Lennart; Kalkman, Jeroen; Verhaegen, Michel; van der Slot, Peter J.M.; Boller, Klaus-Jochen

### Publication date

2017

### Document Version

Final published version

### Citation (APA)

Taballione, C., Agbana, T., Vdovin, G., Hoekman, M., Wevers, L., Kalkman, J., Verhaegen, M., van der Slot, P. J. M., & Boller, K.-J. (2017). *Temperature-immune readout of an integrated optical wavelength meter based on microring resonators*. Poster session presented at ECIO 2017: 19th European Conference on Integrated Optics, Eindhoven, Netherlands.

### Important note

To cite this publication, please use the final published version (if applicable).  
Please check the document version above.

### Copyright

Other than for strictly personal use, it is not permitted to download, forward or distribute the text or part of it, without the consent of the author(s) and/or copyright holder(s), unless the work is under an open content license such as Creative Commons.

### Takedown policy

Please contact us and provide details if you believe this document breaches copyrights.  
We will remove access to the work immediately and investigate your claim.

# Temperature-immune readout of an integrated optical wavelength meter based on microring resonators

**Caterina TABALLIONE<sup>1</sup>, Temitope AGBANA<sup>2</sup>, Gleb VDOVINE<sup>2</sup>, Marcel HOEKMAN<sup>3</sup>, Lennart WEVERS<sup>3</sup>, Jeroen KALKMAN<sup>2</sup>, Michel VERHAEGEN<sup>2</sup>, Peter J.M. VAN DER SLOT<sup>1</sup> and Klaus-Jochen BOLLER<sup>1</sup>**

<sup>1</sup> University of Twente, P.O. Box 217, 7500 AE Enschede,

<sup>2</sup> University of Delft, P.O. Box 5, 2600 AA Delft,

<sup>3</sup> LioniX International BV, P.O. Box 456, 7500 AL Enschede

E-mail: [c.taballione@utwente.nl](mailto:c.taballione@utwente.nl)

Wavelength meters are central for many applications such as in telecommunication systems [1] or laser monitoring [2]. The primary function of a wavelength meter is to provide an output signal that changes sensitively with the wavelength of the input light. Of central importance is the reproducibility of the output signal even in the presence of external perturbations, e.g., temperature changes causing thermal drift. Various different methods are usually applied to improve reproducibility, e.g., thermal stabilization or repeated calibration with an additional reference light source of well-known and stable wavelength.

We present an integrated optical wavelength meter that is immune to thermal drift, requiring no thermal stabilization or repeated calibration with additional light sources. Our experimental approach is depicted in Fig.1. The first central component is an optically integrated Si<sub>3</sub>N<sub>4</sub> waveguide micro ring resonator (MRR) whose optical transmission spectrum can be changed via applying a heating voltage,  $V$ , as a control parameter. The second essential component is a neural network-based readout algorithm that is able to detect temperature changes and reduce their effect on the displayed output wavelength. The wavelength meter is calibrated and characterized with input from a tunable laser and a detector that measures the transmitted power. For the initial calibration the laser is tuned to a large number (e.g. 1000) of different but known wavelengths, for each wavelength a set of different values for the control parameter (e.g. 20 voltages) is sequentially applied, and for each wavelength-control parameter combination the output power signal is recorded.

Thereafter, for measuring a single unknown input wavelength, the transmitted power is measured for the same set of control parameters values. This provides a set of output powers per unknown wavelength. Minimizing the mean-square deviation as compared to the calibration[3] yields the measured (displayed) value for the unknown wavelength.

Three main results can be reported so far: first, when increasing the number of known input wavelengths and heating voltages in the initial calibration the measured wavelengths become increasingly more precise; second, we demonstrate for the first time the long-term reproducibility of such a wavelength meter (here up to one week); third, we observe that the displayed output wavelength does not change when deliberately changing the ambient temperature up to several degrees. The latter result shows that the readout provides temperature-immune operation of the wavelength meter, which makes a precise temperature stabilization or re-calibration after temperature change obsolete.

The current wavelength range of operation spans one free spectral range (FSR) of the MRR of 4 nm with a high spectral resolution of  $\sim 75$  pm. An extension of the FSR is possible via exploiting waveguide birefringence of the MRR or using sequential resonators, e.g., in a Vernier fashion.

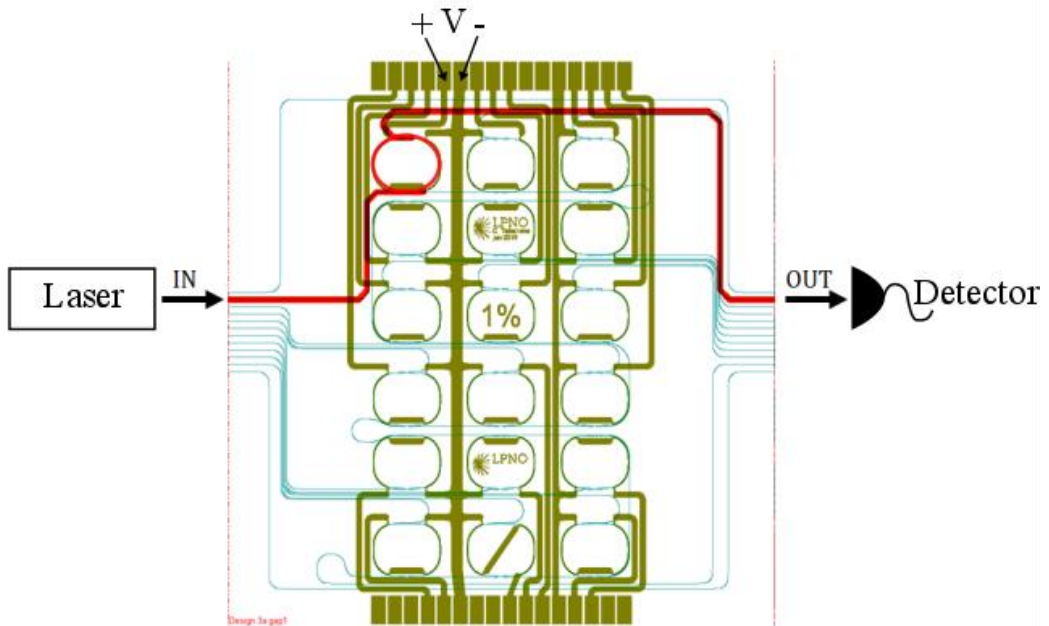

**Fig. 1 Schematic setup for calibrating and characterizing the wavelength meter. Current measurements are carried out with resonators having moderate quality factors ( $Q \sim 1000$ ). The shown resonator circuit has been fabricated for higher  $Q$ -values ( $\sim 1$  million). The light path through on the resonators is shown in red (other waveguides shown in blue). Electric microwires (green) are used for resistive heating via a voltage,  $V$ , as control parameter.**

## References

- [1] Y. Zhang, et al., *Towards adaptively tuned silicon microring resonators for optical networks-on-chip applications*, IEEE JSTQE, vol. 20, no. 4, 2014
- [2] S. A. Saakyan et al., *Frequency control of tunable lasers using a frequency-calibrated lambda-meter in an experiment on preparation of Rydberg atoms in a magneto-optical trap*, Quantum Electronics, vol. 45, no. 9, pp. 828-832, 2015
- [3] R. M. Oldenbeuving et al., *High precision wavelength estimation method for integrated optics*, Optics Express, vol. 21, no. 14, pp. 17042-17052, 2013