

Master Thesis

AUDI UF35

URBAN SHARED MOBILITY

Graduate student

T.J. Lotgering

Supervisory Team

E.D. van Grondelle

W.F. Kets

P. Zeinar

Delft University of Technology

Industrial Design Engineering

Master Integrated Product Design

AUDI UF35 URBAN SHARED MOBILITY

Disclaimer

This master thesis is written in the context of the master Integrated Product Design at the faculty of Industrial Design Engineering at the Delft University of Technology in The Netherlands.

Graduate Student

T.J. Lotgering (Titus)

Student registration number: 4159896

tituslotgering@gmail.com

Supervisory team

Chair: E.D. van Grondelle (Elmer)

Mentor: W.F. Kets (Wouter)

Mentor Audi AG: P. Zeinar (Peter)

Client

Audi AG

Ingolstadt, Germany

2019



AUDI UF35 URBAN SHARED MOBILITY

Contents

- A Preface
- B Acknowledgements
- C Executive Summary

Chapter 1

Project Outline

- 1.1 Project Partners
- 1.2 project Goals
- 1.3 Design Topic
- 1.4 Assignment
- 1.5 Method & Structure

Chapter 2

Analysis

- 2.1 The Company
- 2.2 The Brand
- 2.3 Context
- 2.4 Shared Mobility

Chapter 3

Vision

- 3.1 Future Context
- 3.2 Mission Statement
- 3.3 Interaction
- 3.4 Product

Chapter 4

Design

- 4.1 Mobility System
- 4.2 Configuration
- 4.3 Ideation & Iteration

Z Bibliography

Chapter 5

Development

- 5.1 Use & Features
- 5.2 Materials & Colour

Chapter 7

Discussion

- 7.1 Recommendations
- 7.2 Project Evaluation
- 7.3 Personal Reflection

Chapter 6

Final Design

A

Preface

This is the thesis related to my graduation project at the Master Integrated Design at the Faculty of Industrial Design Engineering at the Delft University of Technology. This project concludes my time as a student and preludes my professional career.

During my internship at Audi Design in 2018, I was given the opportunity to carry out my graduation project in collaboration with Audi. Audi offered me support by giving me access to their resources and facilities, as well as providing me with personal guidance for seven months.

I was intrigued to conduct a collaborative project involving the Delft University of Technology and Audi. During the internship at Audi, I noticed that the industry and the university differ in their project thinking and acting. Due to this, I expected challenges which I'd never encountered before in a project. And indeed, these challenges were very much present.

Being the link between the university and the company, I've pushed myself to represent the knowledge that I've gained during my studies and combine this with "the Audi way" in a manner that shows the values of all involved.

Altogether, I can say that this project has been a wildly enriching and exciting experience for me.

Titus Lotgering

Ingolstadt, June 2019

B

Acknowledgements

I would like to express my dearest gratitude to all who facilitated, supported and encouraged me during the project.

From the TU Delft:

Elmer van Grondelle and Wouter Kets.

From Audi:

André Georgi and Peter Zeinar.

Furthermore from Audi:

Alessandro Rota, Andrea Staebner, André Blum, Daniël de Jong, Edwin Ollefers, Herbert Frühwald, Markus Schmidt, Robert Lang, Calvin Tsui, Ramon Bäurle, Raúl Cano and Sarkis Benliyan.

My parents.

My friends and my girlfriend.

C

Executive Summary

This report presents the design process of "Audi UF35", an urban shared mobility concept for Audi Millennials in the year 2035, carried out for Audi AG.

PROBLEM

The 21st century is increasingly concerned with environmental and sociological problems caused by inefficient use of resources. As more people migrate towards cities, a rapid increase in motorization rates and the number of private vehicles will further aggravate the already apparent urban challenges. Factors such as increased congestion, pollution and noise will result in a deteriorating life quality in cities for its inhabitants.

Due to the fact that younger generations have a more progressive stance towards sharing services, proven by the success of companies such as Uber and AirBnB, sharing economies hold great disruptive potential in terms of urban transport.

Cities are taking action against private ownership. European cities make room

for pedestrians by blocking privately owned vehicles and by giving priority to shared mobility systems.

VISION

As cities grow bigger and stronger, more issues will be addressed directly at the city level. Planned growth in Europe has provided the time and resources for smart city planning. The systematic analysis of monitored data will lead to a more efficient world. The efficiency will translate into how Audi Millennials will use products and their services. They as consumers will demand a constant and seamless integration concerning mobility.

Cities are blocking the use of privately owned vehicles in their centres. Even though cities are becoming more efficient and sprawled with a wide variety of efficient travel modes, Audi Millennials are forced to transfer from one transportation mode (and provider) to another in order to get to their destinations. This inconvenience leaves the door open to more premium travel experiences. Being able to provide a single travel mode and provider that will grant them

access to all the city's destinations will grant a premium experience through accessibility.

"In the domain of European Audi Millennial Mobility in 2035, I want people to experience ennobled door-to-door transit."

DESIGN

The design makes use of two transport modes. One for travel on the city's main roads and one for access to the city's car-blocked areas. The first transport mode is a mobile HUB, which provides comfortable travel on the city's main roads. The so called last-mile EV's grant the user access to car-blocked areas of the city.

The integrated last-mile EV has been further developed.



Project Outline

This chapter describes the role and background of the partners involved in this project. Furthermore, it elaborates the project goals, the design topic, assignment and provides an overview of the design method and project structure.

The bottom line:

- Free to choose my own topic: Investigating the opportunities of shared mobility for Audi.
- Design an urban shared mobility concept injected with true Audi DNA. A design that is beneficial to European cities.
- The method used in this graduation project is based on the Vision in Product Design method.

Project Partners

AUDI AG

Audi AG is a German automobile manufacturer that designs, engineers, produces, markets and distributes vehicles. Since 1965, Audi has been a member of the Volkswagen Group. Its headquarters is located in Ingolstadt, Germany. More than 90.000 employees work for the company. With a revenue of €59.25 billion in 2018, Audi is among the best-selling premium automobile brands in the world (Audi AG, 2018).

AUDI AG'S PROJECT ROLE

Audi is the facilitating company of this project. Providing me, as a graduate student to use their facilities, resources and knowledge. They conducted the consulting role and guided the project towards a relevant, feasible and professional result.

TU DELFT

The Delft University of Technology (from now on referred to as TU Delft) is the largest and oldest Dutch public technological university. It is located in Delft, the Netherlands and hosts over 19.000 students and more than 2.900 scientists. This project was carried out on behalf of TU Delft's faculty of Industrial Design Engineering and in relation to the master Integrated Product Design. This masters degree focusses on how to design user-centred innovative products and product service combinations, based on a balance between the interests of users, business and societal challenges (TU Delft, 2019).

TU DELFT'S PROJECT ROLE

For this project the TU Delft representative is E.D. van Grondelle and W.F. Kets. The university has the guiding role in this project. They are the authority which is responsible for assessing the project according to academic guidelines.



1.2

Project Goals

The goal of this project is to provide insight into the possibilities of shared mobility solutions for Audi in an urban context. To achieve a relevant and realistic result, the design proposal should inherit coherency throughout the entire project; starting from logical reasoning and academic research into a professionally executed design.

The outcome of this project is to be demonstrated through a design proposal, visualized through sketches, renderings, a scale model and a video animation. When all is correctly executed, this thesis aims to inspire Audi Design and the university.

1.3

Design Topic

Audi allowed me to choose the project's topic freely. I decided to investigate shared mobility solutions for Audi, with a focus on Hardware & Interface solutions.

The assignment has been further defined along the course of the project. The design topic consists out of four components that have been fixed before the start of the project; Purpose-built shared mobility, designed for around the year 2035, built for European cities, targeting Millennials.

PURPOSE-BUILT SHARED MOBILITY

Shared mobility has quickly reached a global market value exceeding \$60 billion across China, Europe and the United States. This rapid growth is expected to continue as self-driving taxis and shuttles become more common, bringing 20% annual growth through 2030 (McKinsey, 2019).

Prominent global players are focusing on entering or expanding in this market. New collaborations are being established to enhance companies' shared mobility portfolios. Audi currently offers shared mobility with its subscription service "Audi on demand". Their most recently released concept cars, Audi Aicon, Audi PB18, Audi AI:ME and Audi AI:TRAIL, are dedicated to specific shared mobility use-cases.

AROUND THE YEAR 2035

The time frame is set to be around 2035 to allow enough design freedom for the exploration of advanced design. Conducting a project for a moment further in time will most likely be too speculative and crosses the border of realistic forecasting.

EUROPEAN CITIES

As the world population rises and more people move towards the cities, urban areas will get densely crowded. It is expected that around 80% of the European population will live in cities in the year 2035 (UN, 2014).

Shared mobility has significant potential to provide an alternative to private vehicle ownership, resulting in huge benefits for cities and its inhabitants.

MILLENNIALS

In 2035 the Millennials will be the largest workforce effectuating an enormous generational impact. They are distinctly different from the generations preceding them (Deloitte, 2019). These differences are relevant to investigate while it poses new challenges and opportunities in terms of design.

1.4

Assignment

MOBILITY CONCEPT

In the automotive industry originality becomes a key factor. In order to arouse interest for this project in the industry, the aim is to stay away from conventions and preconceived notions. The aim is to create a mobility concept that is as advanced as possible, yet acceptable for the target audience. Taking this in regard the project has underlying forthought incorporating balance between the expectations of the industry in terms of originality and the expectations from the university in terms of logic and reasoning to create a relatable but feasible mobility concept.

TRUE AUDI DNA

Since this project is being carried out for Audi, the challenge is to make a design that fully matches the brand. The aim is to make a concept that is a fully-fledged Audi in terms of design principle, strategy and styling. When executed correctly, a coherent design is created that can't be easily copied by another brand.

FOCUS

The project will focus on hardware and interface solutions, the aim is to create a product that has a positive impact on the world. At the faculty of industrial design of TU Delft, students learn methods to create a design that does not meet people's current needs, but create a design that fullfills people's future needs. In this way the designer takes responsibility for what he or she brings into our world. The method to achieve this is described in the following section.



DESIGN AN URBAN SHARED MOBILITY CONCEPT INJECTED WITH
TRUE AUDI DNA. A DESIGN THAT IS BENEFICIAL TO EUROPEAN CITIES.

Method & Structure

METHOD

At the TU Delft students learn to provide structure to their design process by using design methods. The method used in this graduation project is loosely based on the Vision in Product Design method (from now on referred to as ViP-method) (Hekkert & Dijk, 2011). The ViP-method is about looking for possibilities, and possible futures, instead of solving present-day problems.

ViP supports the designer to understand upfront what kind of product qualities are meaningful to a future context, making it a context-driven approach. The ViP-method is not a fixed methodology but facilitates a guideline on how to approach a design task.

STRUCTURE

Analysis

The analysis investigates three main topics; the brand, the design context and shared mobility.

The first topic is the brand. It presents Audi's history and values. Furthermore, it investigates the Audi's products and how the brand appeals to their customers.

The second topic describes the design context. It takes a closer look at present-day urban challenges.

The third topic provides an overview of shared mobility. Furthermore, it investigates the motivation behind the phenomenon.

Vision

The second chapter follows the steps of the ViP-method. Firstly, the future vision is described from which the project's mission statement is derived. Secondly the human-product interaction is defined. An analogy is used to clarify the abstractness of the interaction. Thirdly, the product characteristics are derived. The findings from this chapter will provide the design input for the following phases of the design process.

Design

This chapter presents the ideation and iteration. The concept's configuration is explained after which the first ideation sketches are presented. The chapter concludes with a design freeze.

Development

This chapter describes the development from design freeze into the final design. The chapter describes the design's dimensions, use, form, technology, materials and colours. The phase concludes by presenting the final design.



1. ANALYSIS



Audi



Shared Mobility



Context



Synthesis



2. VISION



Mission



Interaction



Product Qualities



Design Input



3. DESIGN



Configuration



Ideation



Design Themes



Design Freeze



4. DEVELOPMENT



Use



Form



Technology



Final Design



1. ANALYSIS



Audi



Shared Mobility



Context



Synthesis



2. VISION



Mission



Interaction



Product Qualities



Design Input



3. DESIGN



Configuration



Ideation



Design Themes



Design Freeze



4. DEVELOPMENT



Use



Form



Technology



Final Design

Analysis

The analysis investigates three main topics; the brand, the design context and shared mobility. The first topic is the brand. It presents Audi's history and values. Furthermore, it investigates the Audi's products and how the brand appeals to their customers. The second topic describes the design context. It takes a closer look at present-day urban challenges. The third topic provides an overview of shared mobility. Furthermore, it investigates the motivation behind the phenomenon.

The bottom line:

- Audi's identity is rooted in their heritage, for Audi this is "Vorsprung durch Technik".
- Audi is in a process of redefining itself for the future as they head into a new age of mobility under the slogan: "Consistently Audi".
- Audi's human-products relationship can best be described as "ennobling".

The Company

This section provides a brief overview of Audi's history and its relation to the Volkswagen Group.

HISTORY

The history of AUDI AG extends back to the 19th century. In 1899 August Horch established the motor vehicle company Horch & Cie., in Cologne. Following differences of opinion with the Board of Management, Horch left the company in 1909 and immediately established a new car company in Zwickau. Because his surname was already in use and protected by trademark, he chose its Latin translation for the new company. So "Horch" became "Audi" (Audi AG, 2018).

In 1932, Audi merged with Horch, DKW, and Wanderer, to form Auto Union AG. The four interlocking rings symbolises the merger of four automobile manufacturers. Audi, DKW, Horch and Wanderer. By that time, Auto Union AG was the second-largest motor vehicle manufacturing group in Germany. Each of the four brands was assigned a specific market segment within the group. DKW for motorcycles and small cars; Wanderer for midsize cars; Audi for cars in the deluxe midsize segment; and Horch for luxury cars at the top end of the market.

In 1945, after the war had ended, Auto Union AG's was located in a Soviet occupied zone. Soviet forces expropriated Auto Union AG's assets, dismantled the plant and had the company removed from the Commercial Register in 1948. A new company called Auto Union GmbH was established in Ingolstadt in 1949 (Audi AG, 2018).

In 1969, NSU, including its slogan "Vorsprung durch Technik", was also added to the Auto Union, after which the company Audi NSU Auto-Union A.G. was called. In 1985 the company name changed to Audi AG.

VOLKSWAGEN GROUP

Since 1965 Audi is part of the Volkswagen Group. The Group consists of 12 brands, including other car manufacturers such as Volkswagen, Porsche, Bentley and Lamborghini, as well as motorcycle and truck brands such as Ducati and Man. Audi manufactures vehicles in seven plants around the world, some of which are shared with other VW Group brands. A revenue of approximately €59 billion in 2018 sets Audi as the second most profitable brand in the Volkswagen Group (Volkswagen AG, 2019).



3 August Horch | Audi Media Center

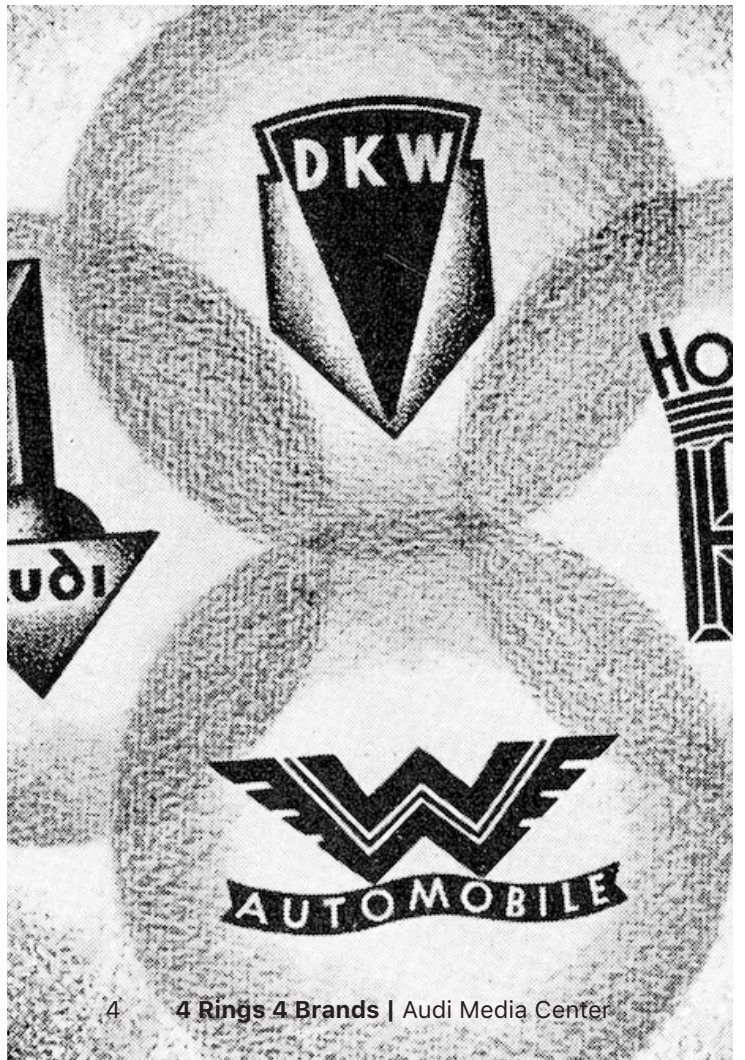

4 4 Rings 4 Brands | Audi Media Center



5 Audiwerke AG Zwickau | Audi Media Center

ELECTRIC HAS GONE AUDI.

6 Audi e-tron Advertisement | Audi Media Center

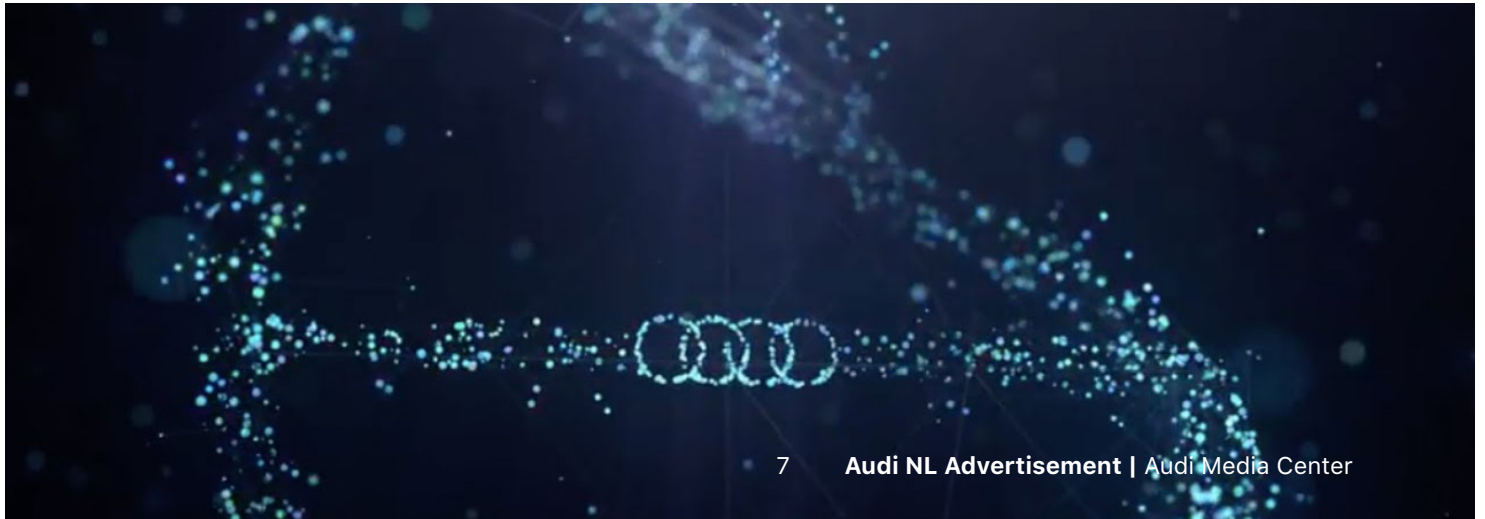

7 Audi NL Advertisement | Audi Media Center

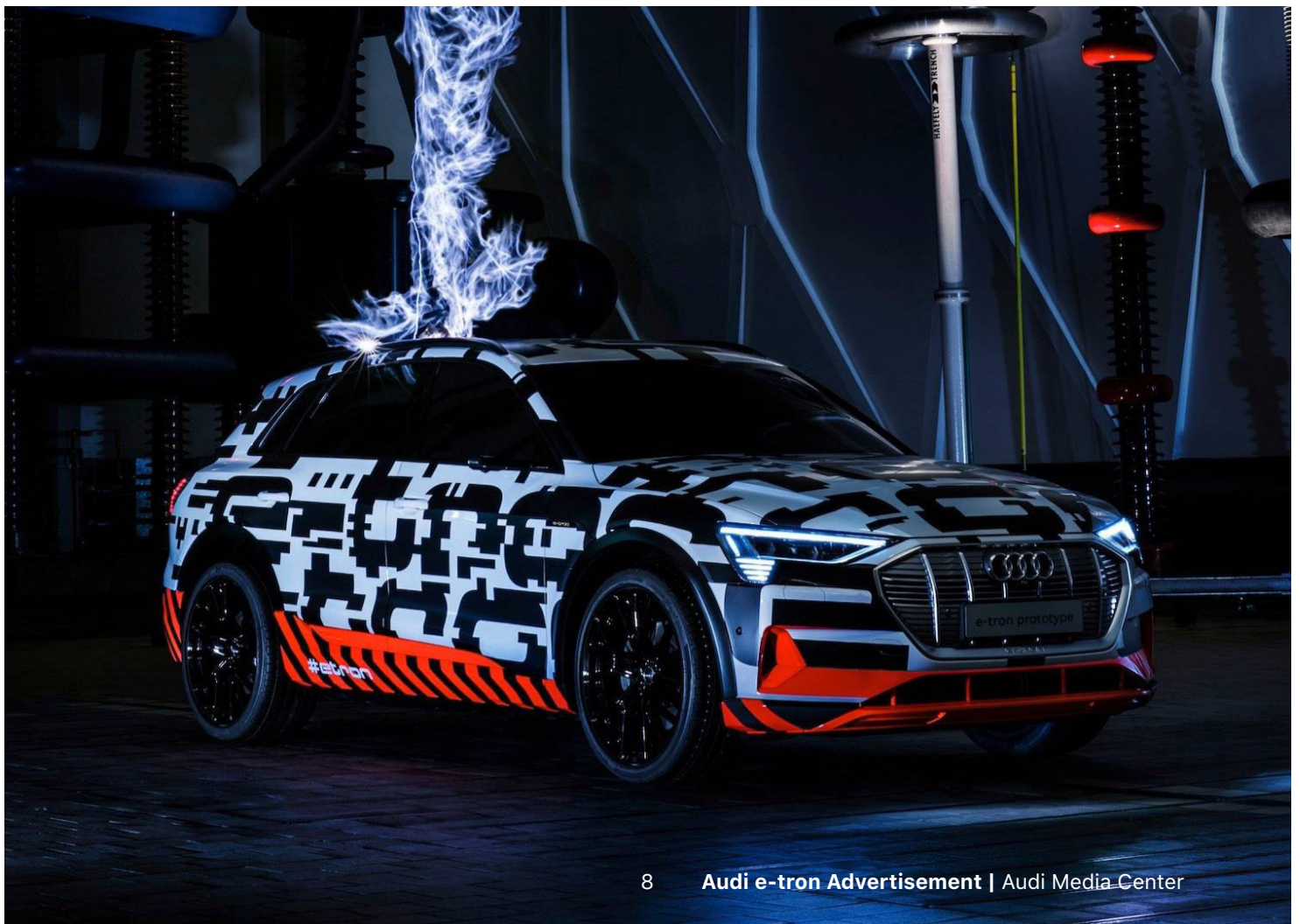

8 Audi e-tron Advertisement | Audi Media Center

The Brand

Before designing a product for Audi, it is important to understand the brand. Every car brand is different and has its own identity. Audi's identity is rooted in their heritage, for Audi this is "Vorsprung durch Technik". This section discusses Audi's values, identity, customer appeal and products.

VORSPRUNG DURCH TECHNIK

Vorsprung durch Technik

The German phrase "Vorsprung durch Technik" is usually translated into English as "progress through technology". A literal translation would be "advancement through technology". There's no single English word which is an exact equivalent of "Vorsprung", "to leap ahead" comes close (Phrases, 2019).

The inventor of the phrase, Sir John Hegarty describes: "It says everything and says nothing. That's often the brilliance of thought, that people put their own meaning into it." - Sir John Hegarty, 2012.

In the radical upheaval of the automotive industry, Audi is in a process of redefining itself for the future as they head into a new age of mobility under the slogan: "Consistently Audi". Audi breaks this down into four main branding values: consistently customer, consistently electric, consistently connected and consistently sustainable (Audi AG, 2019).

Consistently Customer

Their customer focus is reflected by their new concept cars, which are based on dedicated use-cases. Audi aims to be the company with the most satisfied customers. Where Audi used to exhibit itself as a highly product-focussed company, they see that today's customers should be addressed differently. Audi is recognizing that experiences will overtake product and price as the main brand differentiator. By approaching things from a customer's perspective, they aim to effectively address customer's current wants and future needs (Audi AG, 2019).

Consistently Electric

The dieselgate scandal negatively shaped the public opinion towards Audi. New legislation concerning CO₂ taxes, forces Audi to put high priority on their electric fleet. Audi believes that electric mobility is the most efficient path to decarbonization (Audi AG, 2019). By the middle of the coming decade, they aim to sell about a million electrified cars each year. By 2025, they aim to reduce the CO₂ footprint of the Audi fleet by 30% over the entire lifecycle, in order to improve Audi's environmental impact.

Consistently Connected and sustainable

By creating an open digital ecosystem, Audi is aiming to offer their customers connectivity. Audi claims to conduct their business responsibly, transparently and with integrity; acting in harmony with ecology and economy and with a clear long-term perspective.

BRAND IDENTITY

Audi's products and human-product relation is expressed by the main branding values. However, the brand also reaches to customers in other ways which are not explicitly mentioned in the branding message.

Uncompromised Premium

Audi offers uncompromised premium cars. The products stand out in their superior quality and strong engineering. The product's superior quality is achieved due to a very precise and perfectionistic execution of even the smallest parts, such as knobs and buttons. An eye-for-detail can be found throughout the whole design; from the consistency of splitlines to the sound that buttons make when pressed. Moreover, this perfectionism and precision is executed throughout the entire company, from the employees meticulous approach to the multiple inspection rounds in the factory. Sometimes even postponing release dates when the product isn't yet up to Audi's standard.

Bauhaus in Motion

Where Audi's direct competitors offer a classy premium (Mercedes) or wild/sporty premium (BMW), Audi offers premium in understatement. Their personality isn't based on subjective pillars but on purpose and logic. It could be described as "Bauhaus", in which form follows function and "unnecessary" aspects are better to be left out. The omitting of irrelevance has become Audi's main differentiator.

Irrational Audi

While Audi designs in a rational and logical way, the brand still speaks to us in an irrational way. Since Walter da Silva's influence on Audi's design, Audi adopted a certain braggadocio, which is displayed by the large front grills and an increased elegant appearance. Audi's current head of design, Marc Lichte, states that Audi's design principle is still clearly influenced by Bauhaus. However, Lichte aims to emphasize a strong character and desirability.

"Our cars are sexy." - Marc Lichte, 2016
(as quoted in Audi Encounter, 2017)

Careful and Progressive,

in my experience Audi identifies itself with these two terms. However, in terms of innovation concerning electric and shared mobility they aren't truly progressive. Competitors like Tesla and BMW have introduced risky new technologies and strategies. Once these have proven themselves, Audi is ready to dive in. Using smart ways of advertising, Audi manages to relate itself to already introduced technologies. Because of this strategy concerning electric and shared mobility Audi is far behind its competitors.

Some wear grey
better than others



Audi Vorsprung durch Technik

9 Audi Advertisement | Audi Media Center



10 Audi Musk-Have Advertisement | Audi Media Center

AUDI'S CUSTOMER APPEAL

In this section it will be described how Audi appeals to the customer group Millennials.

Audi's customer research points out that the brand attracts people with high social status. These people hold modern to progressive basic values (Audi AG, 2018).

People with modern basic values are striving for self-enhancement. They possess individualistic, egocentric and status-striving characteristics. They are tech-savvy and spent a relatively large amount of time online. They want to escape the norm and deny social constraints. People with progressive basic values possess a left-wing orientation. They are socio-cultural open-minded and seek thrill and adventure. They consume responsibly and strive for flexibility both professionally as personally. They are life-long learners (Audi AG, 2018).

Aesthetical and Meaningful Attraction

Audi's design displays ease of use and an almost placative clarity of function. As I have experienced, Audi highlights the product's technological features and design them with high quality, refinement and precision that they could be considered as detailed as jewellery. The combination of meaningful use and highly aesthetic properties of Audi's design attracts their customers.

Ennobling

Audi's products provide the user with a sense of sophistication and delicacy. As I interpret the interaction between Audi users and the product could best be described as "ennobling". Seemingly standard use tasks are elevated to such a level that the user will feel upranked.

A Face in the Crowd

As described in the previous section, Audi's personality isn't based on subjective pillars, such as bourgeois or wildness. This lack of subjectiveness results in the vehicle's relatively subdued appearance. This in combination with the vehicle's high performance and comfort, attracts their customers. Audi's customers want to bathe in power and luxury, while being a face in the crowd.



11 Audi Customers | Audi Media Center



12 Audi AI:TRAIL | Audi Media Center



13 **Auto Union Typ D 1911** | Audi Media Center



14 **Audi TT Concept 1995** | Audi Media Center



15 **Audi e-tron 2018** | Audi Media Center



16 **Audi Q4 e-tron 2019** | Audi Media Center



17 **Audi PB18 2018** | Audi Media Center



18 **Audi AI:ME 2019** | Audi Media Center

THE PRODUCTS

This section describes how Audi expresses their "Vorsprung durch Technik" through design.

Earlier models, like the Audi TT, directly translate Audi's message into form. Its styling principles are logical and rational sculptures. Lines and surfaces relate directly to each other, which creates Audi's inherent logic. Clearly defined volumes and uncomprehensive surfaces result in unmistakable clarity. Audi's current and concept vehicles display how Audi aims for high desirability, by more elegantly shaping the cars.

Audi's products are highly sophisticated and precise. They achieve this by minutely treat the product on all levels; from proportions to detailing to colour and trim.

Volumes look like they can be constructed in a few actions, obtaining visual clarity. Audi doesn't make use of comprehensive intertwined surfaces. Surfaces logically react to the product's volumes and linework.

Components are integrated into the main interior architecture of the vehicle. Technical components are highlighted and made aesthetically appealing. These components play a centerpiece role in the vehicle's exterior and interior.

Touchpoint components are designed with high precision and adequacy conforming to the highest standards of comfort. Audi obtains this by visually, audibly and ergonomically refining every single car part.

Context

Urban Challenges

The 21st century is increasingly concerned with the environment and with the social problems caused by the indiscriminate use of natural resources, the absence of urban planning, and the deteriorating quality of life for inhabitants of large cities.

According to the World Bank (#fixme), by 2050, the equivalent of 2/3rds of the projected global population (about 5.4 billion people) will live in urban areas, and the number of vehicles on the road will double, to reach 2 billion. While these changes have benefitted many individuals, they have also created difficulties such as increased traffic jams and the environmental deterioration of urban areas.

According to Pojani and Stead, some trends in many cities around the world are: extensive urban sprawl, rapidly-growing motorization, inadequate public transport systems, chaotic traffic patterns with high use of cars and motorcycles, high environmental pollution, and poor infrastructure for pedestrians and cyclists. Thus, more people prefer to own and use private vehicles, further aggravating the problems (Machado, C. & de Salles Hue, N. & Berssaneti, F. & Quintanilha, J., 2018).

Sharing Economy

Nowadays, an alternative stance is concerned with services, which can be observed in the growing popularity of short-term rental systems of

vehicles. In this context, the concept of a sharing economy emerges as a new paradigm that enables access to goods and services beyond ownership.

Sharing economies have the potential to encourage the distribution and use of underutilized assets and to promote a more sustainable consumption, with economic, social, and environmental consequences (Machado, C. & de Salles Hue, N. & Berssaneti, F. & Quintanilha, J., 2018).

Cities Versus Private Ownership

Multiple European cities are taking action against the use of privately owned vehicles in city centers. Oslo will ban cars from the city center by the year 2025. London charges for inner city traffic and plans to ban ICE by the year 2020.

Barcelona introduced 'Superblocks'. Superblocks are made up of a grid of basic roads forming a polygon, some 400 by 400 meters, with both interior and exterior components. The interior is closed to motorized vehicles and above ground parking, and gives preference to pedestrian traffic in the public space. The inner streets are generally reserved for pedestrians. The perimeter of Superblocks is where motorized traffic circulates, and makes up the basic roads (#fixme). The application of the Superblock significantly improves urban quality while reducing the environmental impacts of vehicles (BCN, 2010).

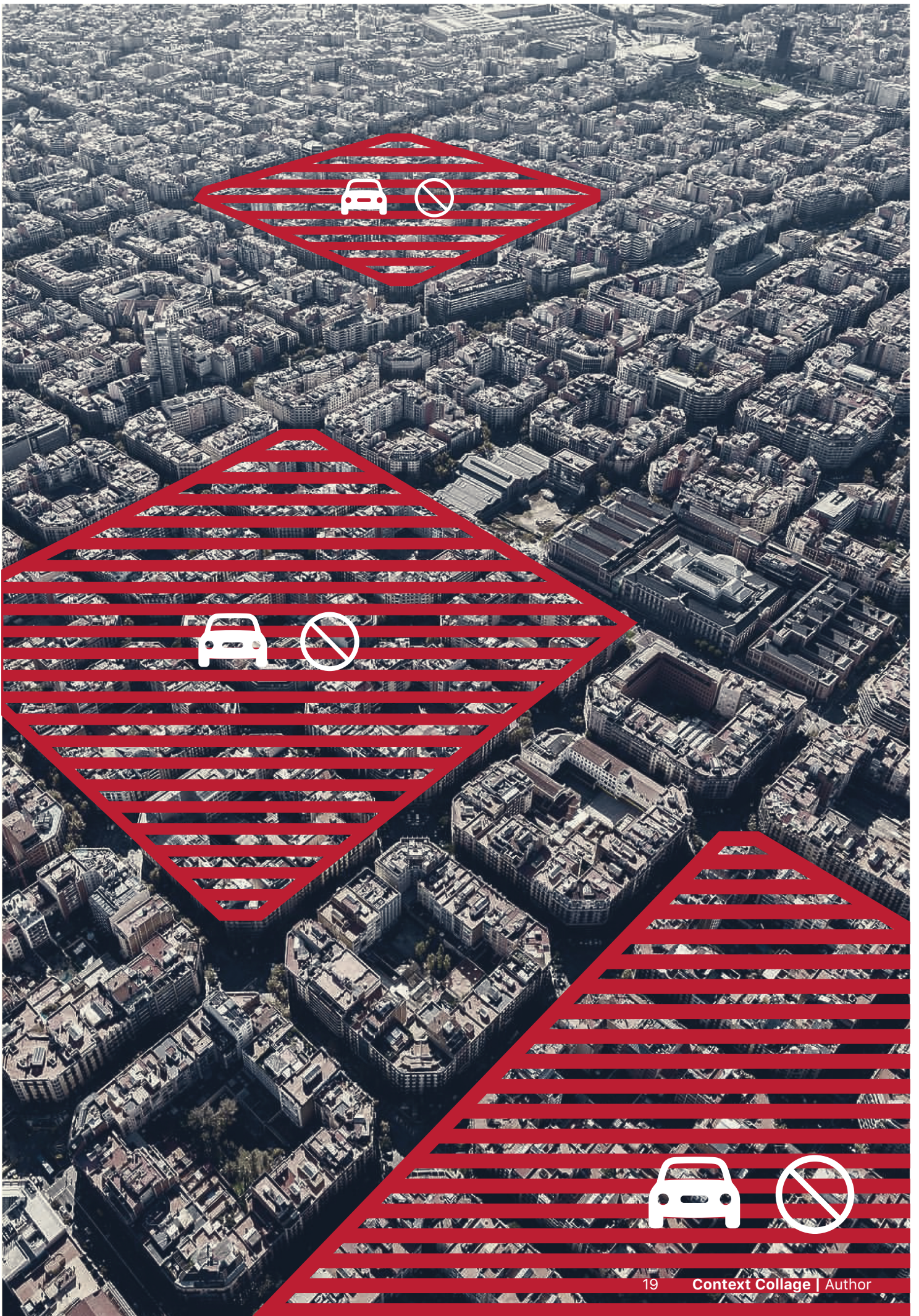

Shared Mobility

DEFINITION OF SHARED MOBILITY

Shared mobility is the shared use of a vehicle, motorcycle, scooter, bicycle, or other travel modes; it provides users with short-term access to a travel mode on an as-needed basis (SAE International, 2018).

Shared mobility is an innovative transportation strategy that enables users to have short-term access to a mode of transportation when required, and can increase multimodality, reduce vehicle ownership, vehicle kilometres travelled and can provide new ways to access goods and services (Machado, C. & de Salles Hue, N. & Berssaneti, F. & Quintanilha, J., 2018).

MOTIVATION OF SHARED MOBILITY

When designing for shared mobility it is necessary to understand what drives the adoption of the phenomenon. The main factors influencing the use of shared mobility are identified. According to LSE Cities and Schaefers (#fixme), the main reasons affecting users' adoption of shared mobility schemes can be accounted to users' mobility patterns, their socioeconomic status and their attitudes and perception.

Financial

The shared mobility service is more economical for users because it is less expensive than acquiring and maintaining a vehicle. Using shared transportation modes allows one to save money for other activities due to fair prices and, usually, free parking (Schaefers, 2013).

Convenience

Ease of use and convenient access to the service. Services aim to facilitate daily routines and offer increased parking spaces, flexible vehicle use, reduced liability, and simplified fare models.

Engagement

This service associates the inherent pleasure of using a private vehicle with the feeling of being engaged in a community with other users. Easy-to-understand symbols associated with shared modes, such as a uniform meet of vehicles identified by special paints or adhesive, can generate a sense of belonging. Thus, users want to have contact with others while simultaneously differentiating themselves.

Environmental

Environmental concerns are considered to be important for improving the quality of life. shared vehicles should reflect environmental and

social awareness, which explains why electric and hybrid vehicles are gaining momentum in shared mobility systems. The electric vehicle is considered fundamental to sustainable development in urban mobility due to its low CO₂ emissions (Machado, C. & de Salles Hue, N. & Berssaneti, F. & Quintanilha, J., 2018).

Autonomy

The main reason negatively influencing the adoption of shared mobility is found in a reduced autonomy. Autonomy pertains to the independence of others in taking decisions regarding mobility. The crucial importance of the flexibility and autonomy provided by privately owned cars, on account of the combined journeys they are required to undertake, whether on business or for private purposes (MaaS Alliance, 2018).

Technology

Another motivation involves the operation of technology, such as the working of an app, dependency on smartphones and their batteries and the availability of Internet connections (#fixme).

Enjoyment

Hamari et al. (2016) stated that participation in the sharing economy is to some degree motivated by enjoyment. According to LSE Cities,

shared mobility interventions should aim at highlighting the enjoyment alternative modes provide, communicating how easy it is to combine public transport with car sharing or cycling across the metropolitan region. This may be best achieved by discovering the pleasure of using travel apps and real-time online services smartly and creatively while also enjoying health and fitness benefits.



1. ANALYSIS



Audi



Shared Mobility



Context



Synthesis



2. VISION



Mission



Interaction



Product Qualities



Design Input



3. DESIGN



Configuration



Ideation



Design Themes



Design Freeze



4. DEVELOPMENT



Use



Form



Technology



Final Design

Vision

The second chapter follows the steps of the ViP-method. Firstly, the future vision is described from which the project's mission statement is derived. Secondly the human-product interaction is defined. An analogy is used to clarify the abstractness of the interaction. Thirdly, the product characteristics are derived. The findings from this chapter will provide the design input for the following phases of the design process.

QUAN

THED

CTY

2035

Future Context

In order to design a product for the year 2035, it is necessary to understand how the current context will develop. A vast amount of context factors related to the design topic have been investigated and clustered into two narratives. These narratives describe the future design context.

QUANTIFIED CITIES

As cities grow bigger and stronger, more and more issues will be addressed directly at the city level. Planned growth in Europe has provided the time and resources for smart city planning. The systematic monitoring of data on patterns leads to a more efficient world. The efficiency will translate how Audi Millennials will use products and services. There is a constant demand for seamless integration.

MULTIMODAL MOBILITY

Cities are blocking the use of privately owned vehicles in their centres. Though cities become more efficient and sprawled with a wide variety of efficient travel modes, Audi Millennials are forced to transfer from one transportation mode (and provider) to another in order to get to their destinations. They'll find that this doesn't meet with their premium travel expectations influenced by their personally owned vehicle and that it takes away parts of their comfort and freedom concerning transit. Therefore, they will demand a single travel mode and provider that will grant them access to all cities' destinations; obtaining premium through accessibility.

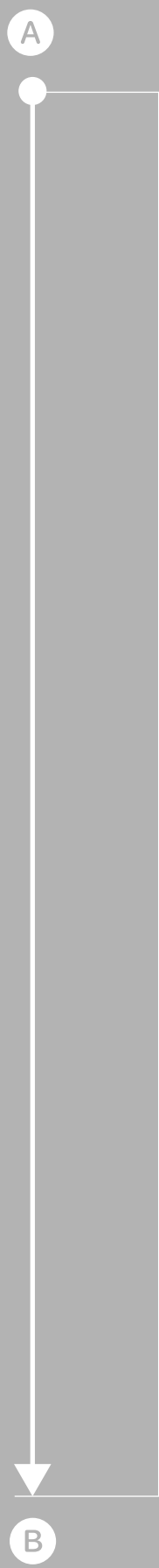

2019

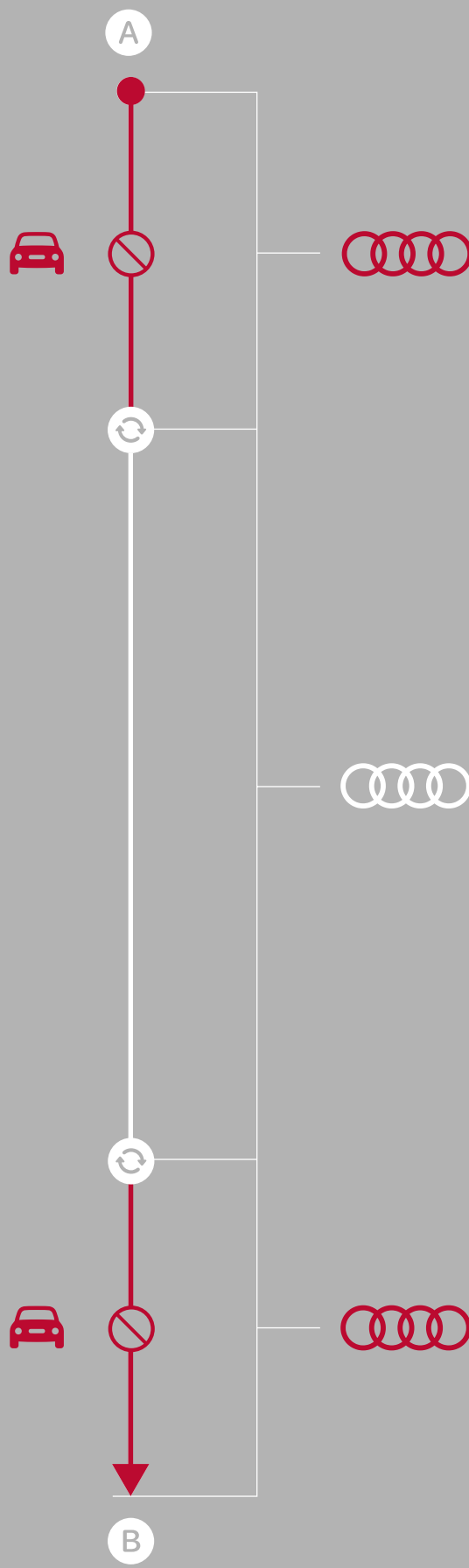

2035

3.2

Mission Statement

Directly derived from the future context, the project's mission statement is composed.

"In the domain of European Audi Millennial Mobility in 2035, I want people to experience ennobled door-to-door transit."

In order to guarantee a fully-fledged Audi experience, Audi must provide an ennobled mobility solution that covers the travelers' complete travel trajectory.



**"IN THE DOMAIN OF EUROPEAN AUDI MILLENNIAL MOBILITY IN 2035, I WANT
PEOPLE TO EXPERIENCE ENNOBLED DOOR-TO-DOOR TRANSIT."**

Interaction

Following the guideline of the ViP-method, the next step is to envision how the users needs to interact with the product in order to achieve the ennobled experience described in the mission statement.

INTERACTION

The interaction can be defined as a combination of the words "smooth and borderless". The user should feel borderless in the efficient future urban environment. He or she must not feel bordered by the cities' regulations and forced to change to transportation modes that don't fit with the Audi Millennial's premium travel expectations. He or she should flow smooth and seamlessly through the city.

ANALOGY

In order to provide a less abstract display of the interaction an analogy is used. The interaction can be described through a scene found in the movie James Bond Spectre.

In this scene James Bond finds himself in a car chase. At a certain point the road is blocked. James Bond activates the ejection seat and shoots out of the car. The parachute is deployed and Bond lands smoothly on a higher level street. He detaches his parachute with a single hand motion and continues his escape calmly in his Tom Ford suit, smoothly escaping his pursuer by blending in the crowd.



SMOOTH AND BORDERLESS



T-11 ADVANCED TACTICAL PARACHUTE SYSTEM

NSN 1670-01-539-4525

HEADQUARTERS, DEPARTMENT OF THE ARMY

Released in 2010

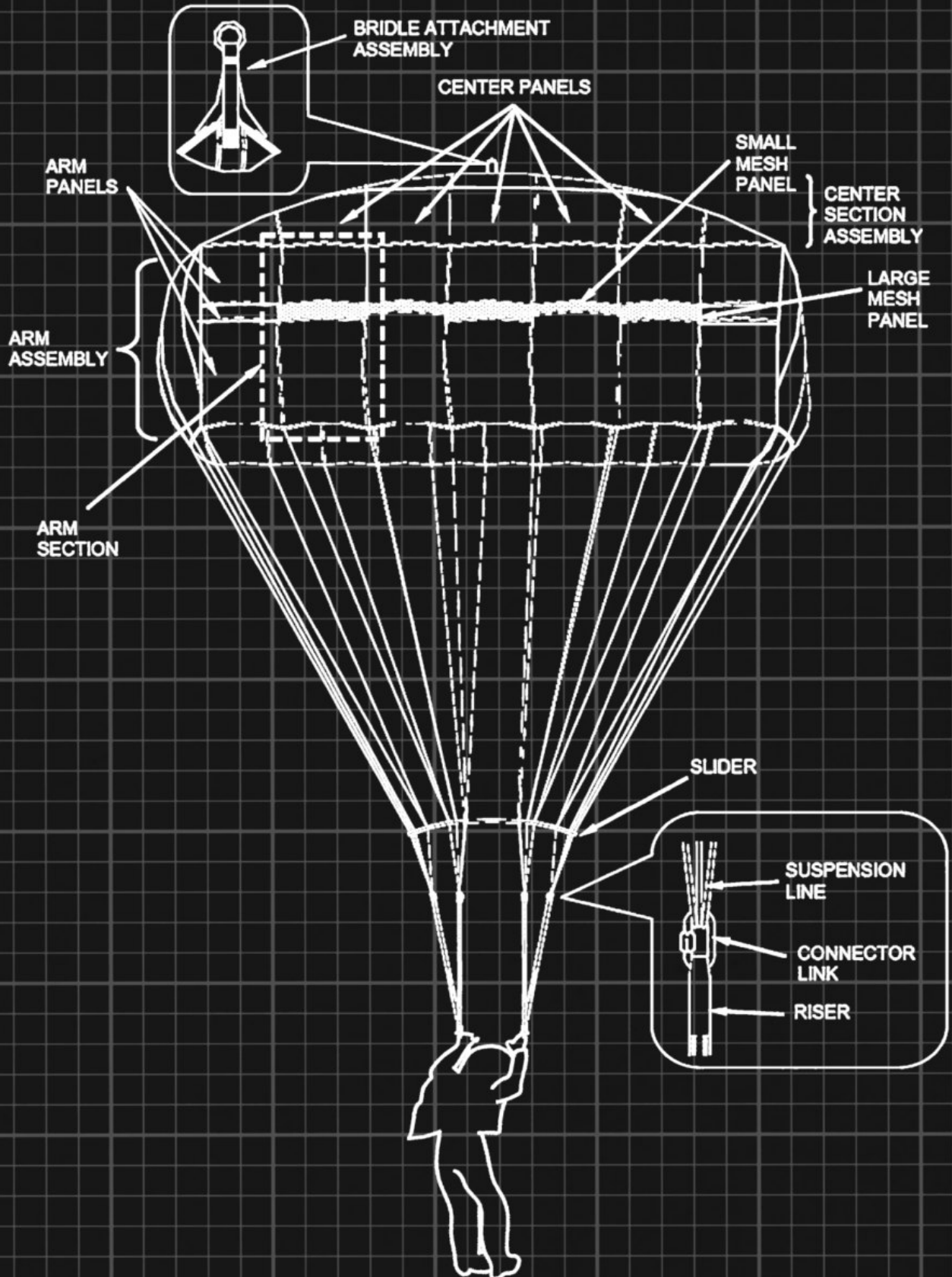

3.4

Product

The next step in the ViP-method describes what characteristics the product should inherit to provide the desired human-product relationship.

Considering the James Bond analogy, the parachute is the object that provides the interaction.

Therefore, the characteristics of the parachute provides guidance for the characteristics that the concept should inherit.

The parachute's characteristics are defined as "Compact" and "Functional".

Being it a compact solution provides the user with a boundless feeling, unobstructed by the object. This borderless feeling is enhanced by a compact deployable system. In one smooth motion, the user can deploy itself from the object.

Moreover, the parachute holds a functional character. Control points are of high clarity in order for the user to directly understand how the product works and should be handled. This clarity is obtained by leaving out unnecessary parts that visually and practically obstruct the user.



COMPACT & FUNCTIONAL





1. ANALYSIS



Audi



Shared Mobility



Context



Synthesis



2. VISION



Mission



Interaction



Product Qualities



Design Input



3. DESIGN



Configuration



Ideation



Design Themes



Design Freeze



4. DEVELOPMENT



Use



Form



Technology



Final Design

Design

This chapter presents the ideation and iteration. Firstly, the concept's configuration is explained after which the first ideation sketches are presented. The chapter concludes with a design freeze.

Bottomline:

- The system makes use of two transport modes. A mobile HUB for travel on the cities main roads and a last-mile EV for access to the cities car-blocked areas.
- The last-mile EV is further developed into a final design.

Mobility System

Initial explanation of the new mobility system. In order to gain ennobled acces all across the city, the system makes use of two transport modes. One for travel on the cities main roads and one for access to the cities car-blocked areas.

MOBILE HUB & LAST-MILE EV'S

The first transport mode is a car, which provides comfortable travel on the cities' main roads. Inspired by how James Bond smoothly switches from one means of transport to the next (from car to parachute) is directly translated into the system's principle. The car contains multiple integrated last-mile EV's, making it a mobile HUB. The last-mile EV's gives the user access to car-blocked areas of the city. The integrated last-mile solution takes care of an uncomprehensive, fast and seamless change of transit mode.

THE BENEFITS

The sytem is mutually beneficial to its users, Audi and the city. Main benefita are as follows:

1. The co-operation between the mobile HUB & integrated Last-Mile EV's provide complete access to all areas of the city in a single mobility solution, avoiding walking distances between transit modes.
2. The mobile HUB can autonomously pick-up and distribute the last-mile EV's accross the city to provide direct mobility on-demand.
3. As a commbined solution. The mobile HUB is mobile, peak times at fixed mobility HUB's can be avoided.

FOCUS

With the project's timeframe in mind, it was decided to further develop one of the two vehicles. In consultation with Audi, it was decided to further develop the integrated last-mile vehicle.

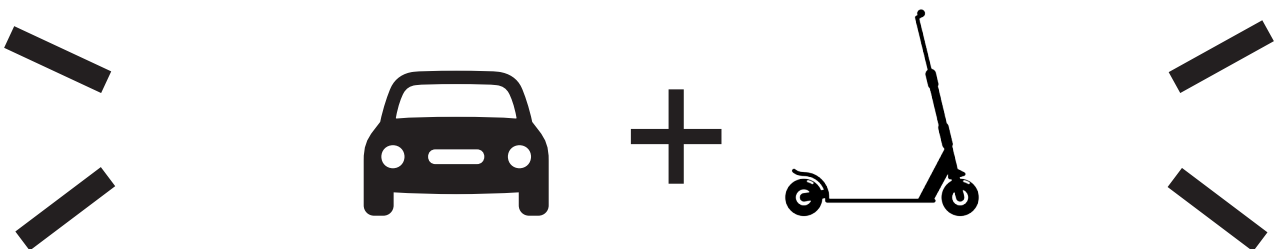

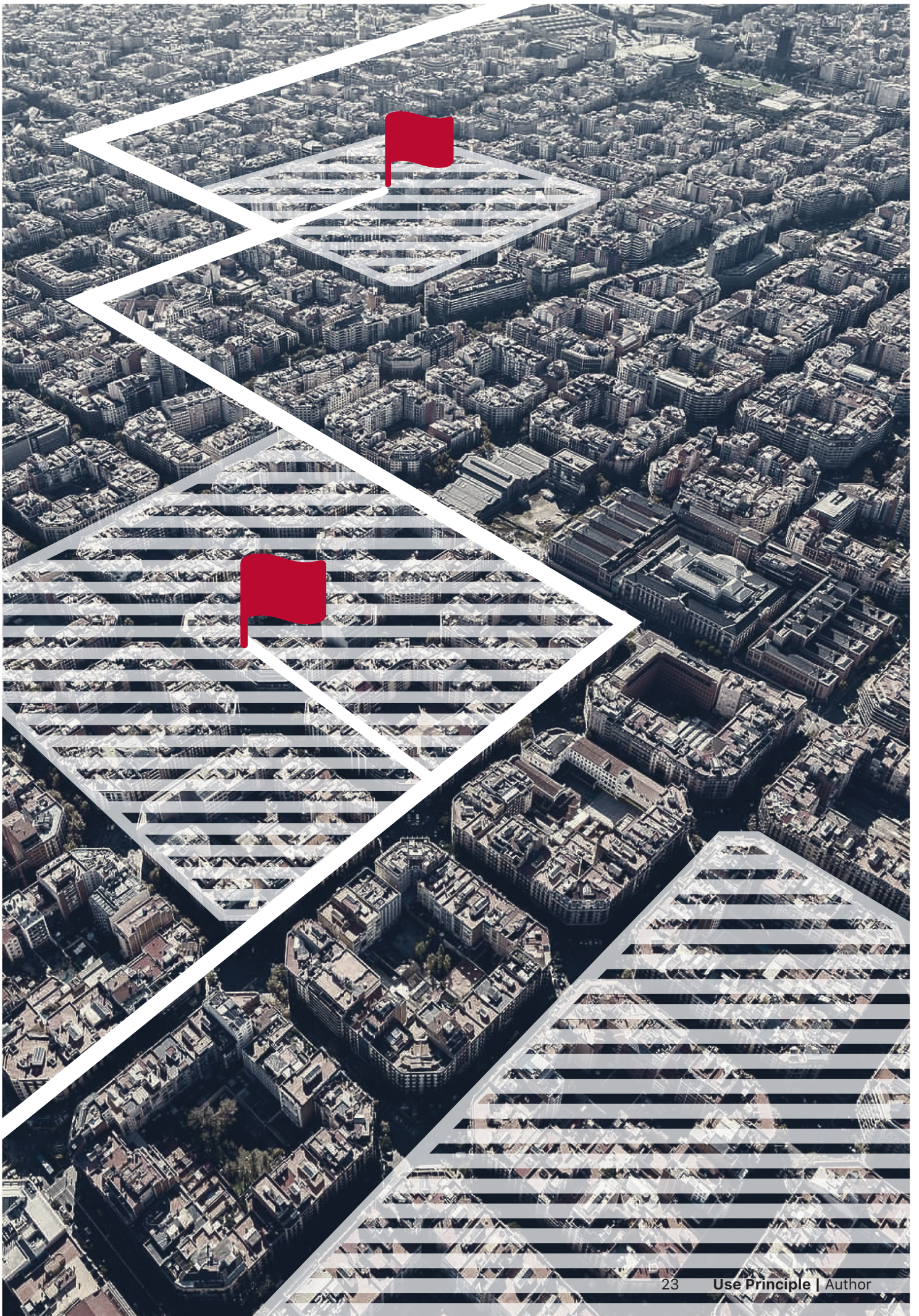

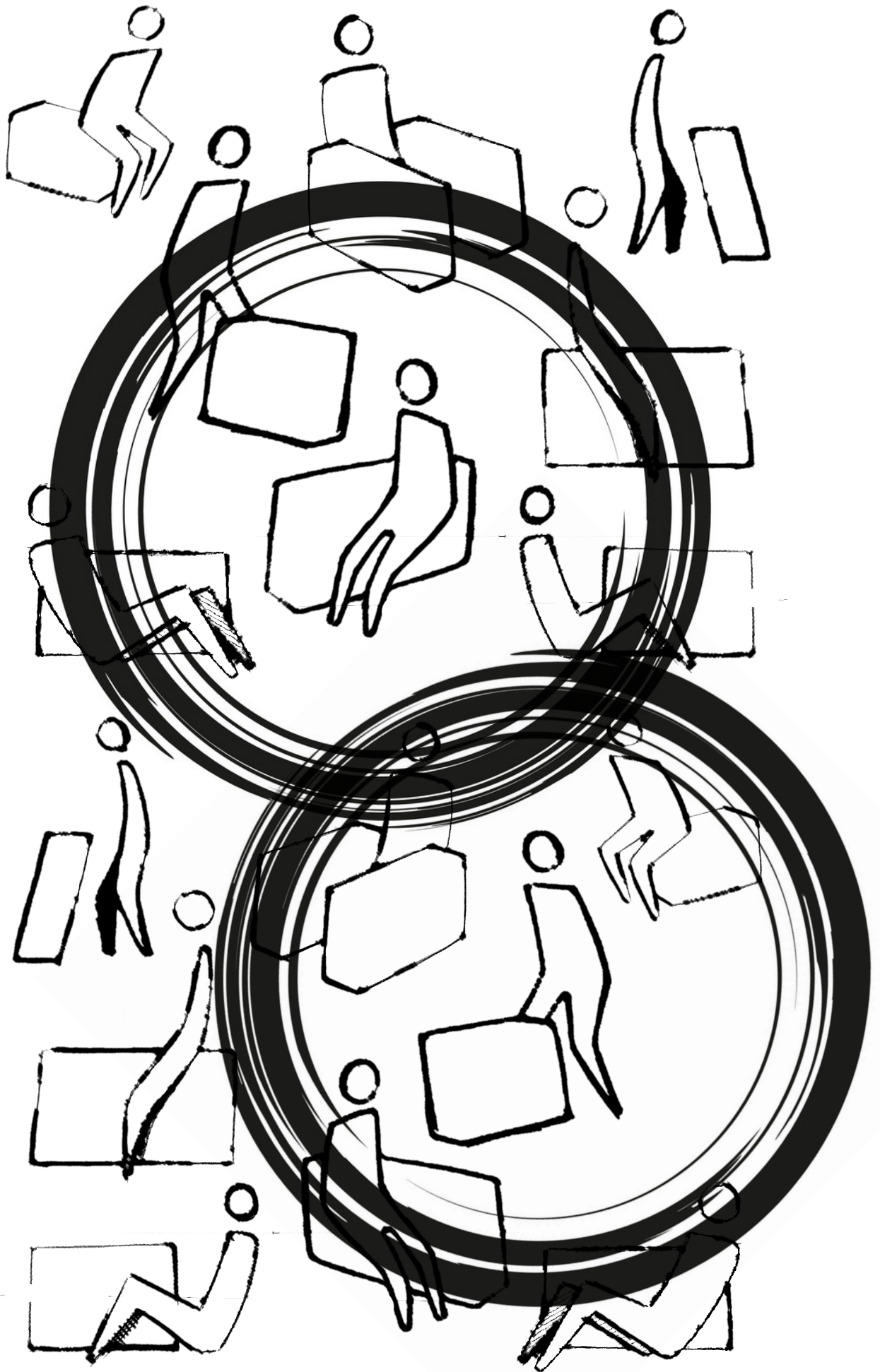

4.2

Configuration

The design phase starts of with the vehicle's configuration. Because currently available last-mile vehicles do not offer a fitting seating position evoking the desired human-product interaction, various configurations have been explored.

In order to facilitate multiple use-cases, a large cargo volume was taken into account. Figure 24 provides an overview of various configurations in user stance and cargo volume.

The two most fitting configurations were chosen to further develop. These two configurations are indicated by circles in figure 24.

Ideation & Iteration

After fixing the configuration, the first ideation sketches were created. In this phase the desired character was explored by means of sketches. The results from this phase were discussed with the client, after which the exploration was narrowed down and a direction was chosen.

In order to find direction in designing a fully-fledged Audi, the functional aspects of the product had been defined. Various use-cases were explored to fix the design's requirements. An airport-to-city use-case was used to set the maximum requirements concerning the amount of luggage. Therefore, the design should provide covered space for a large check-in bag, a large cabin bag, two accessory bags and a jacket.

At this point there wasn't yet a decision made on the two configuration stances. Therefore, the two stances derived from the configuration exploration were developed into two main design themes. These themes were based on the desired character, being compact and functional. The following pages provide visual explanation on how the design evolved.

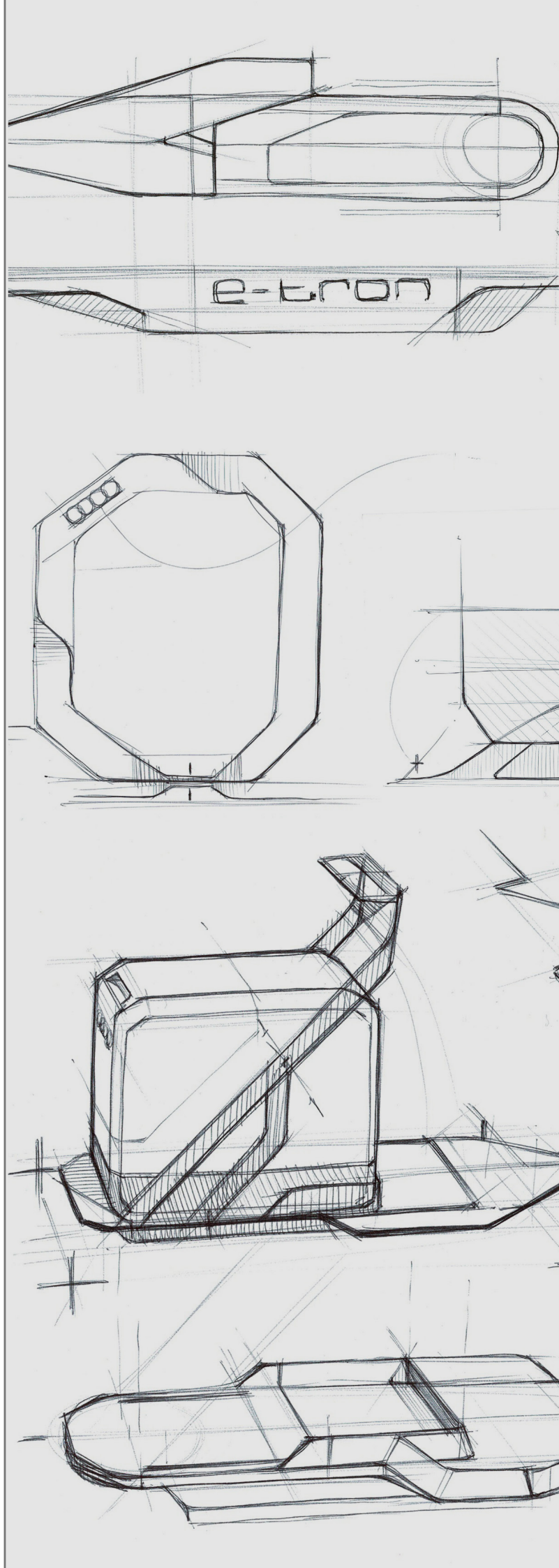

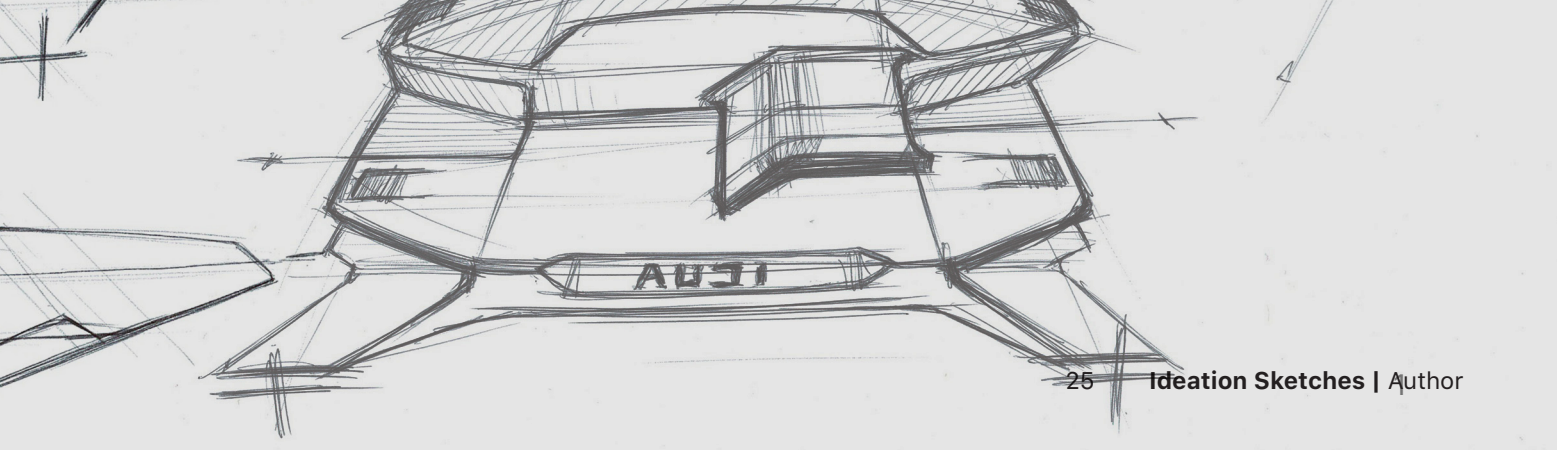
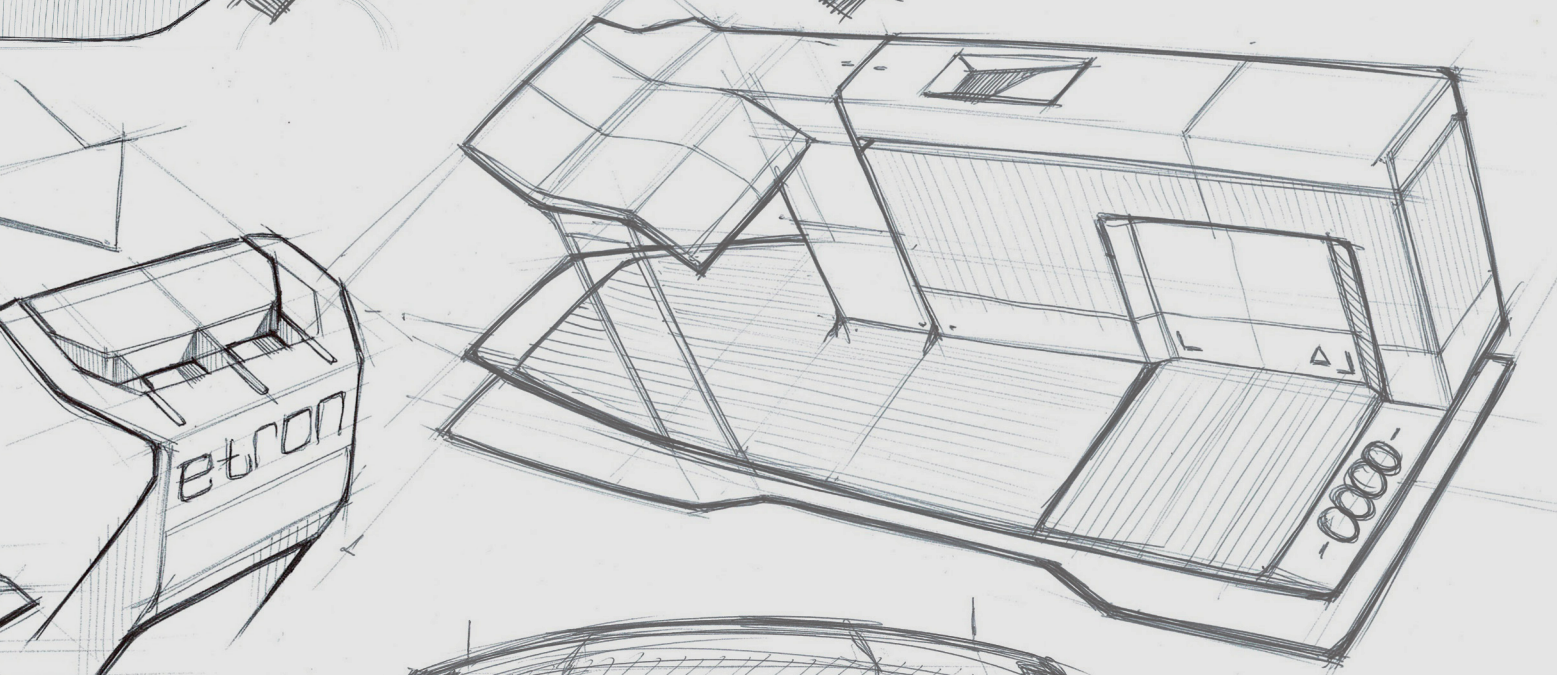
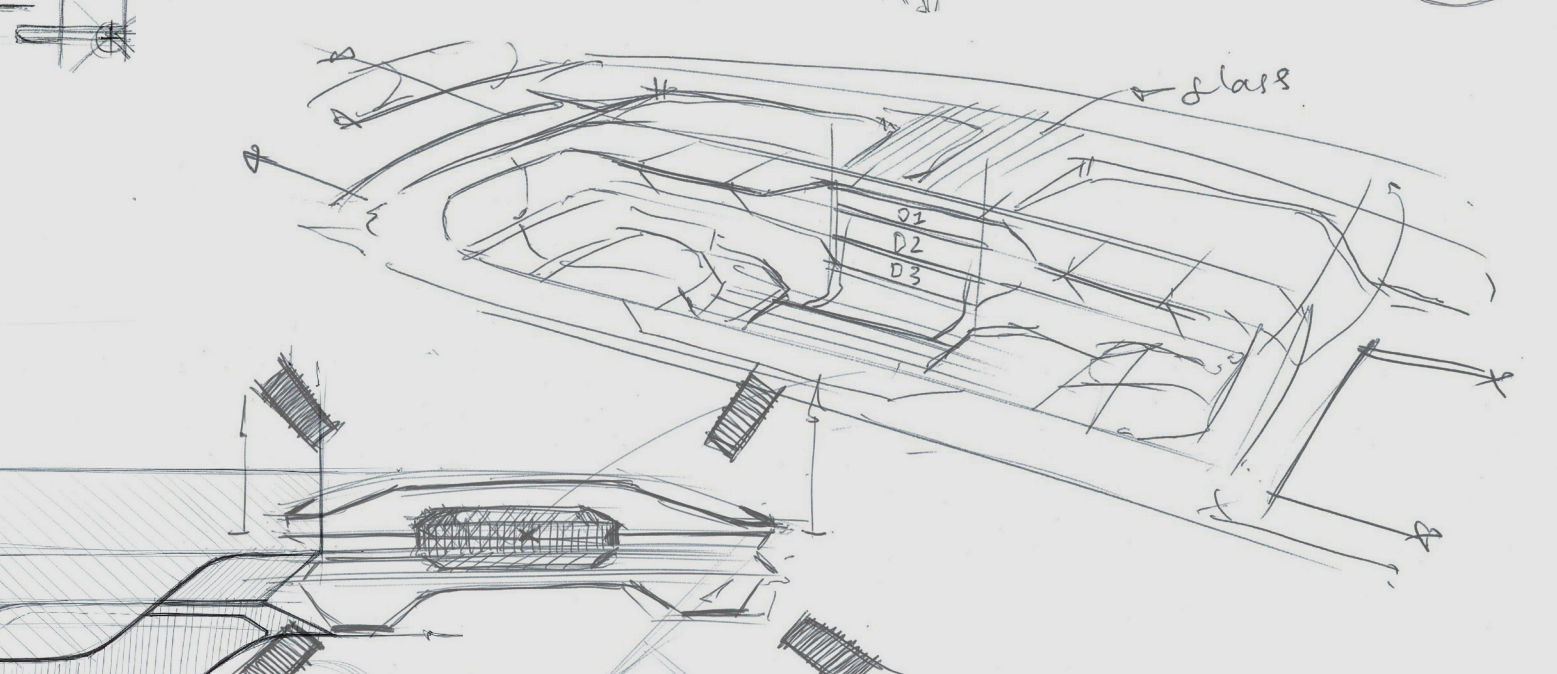
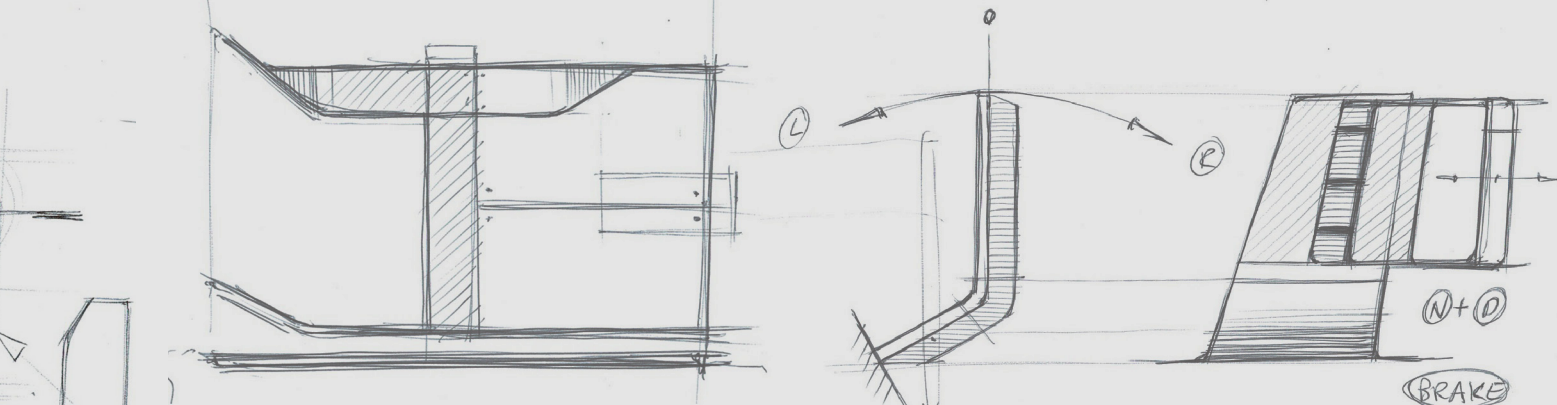

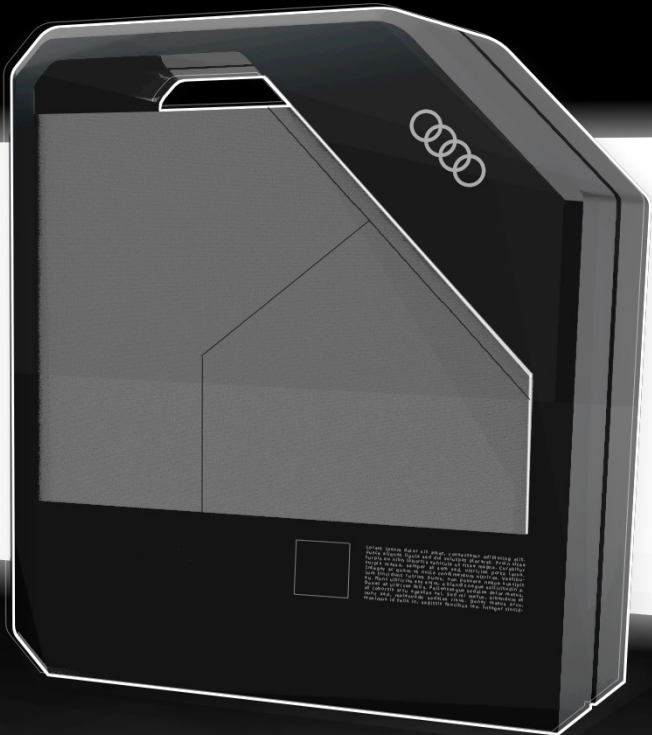

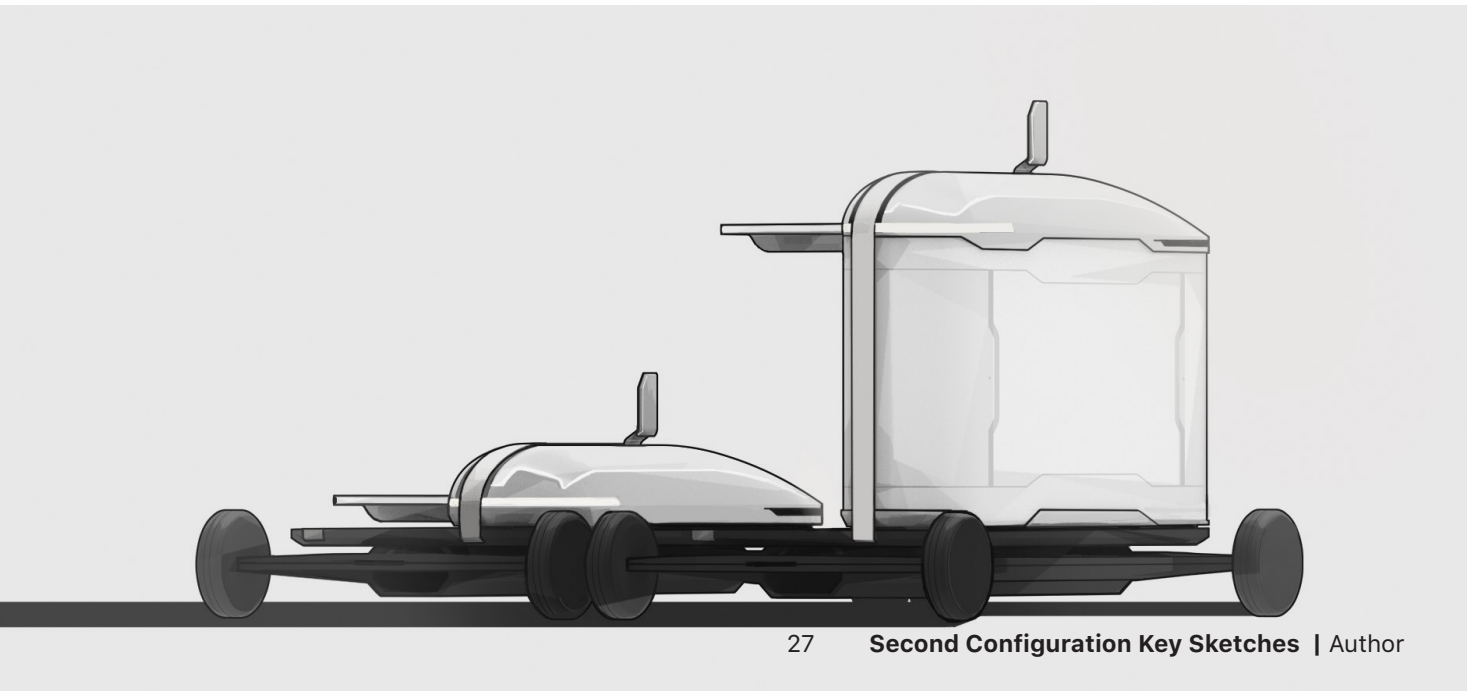
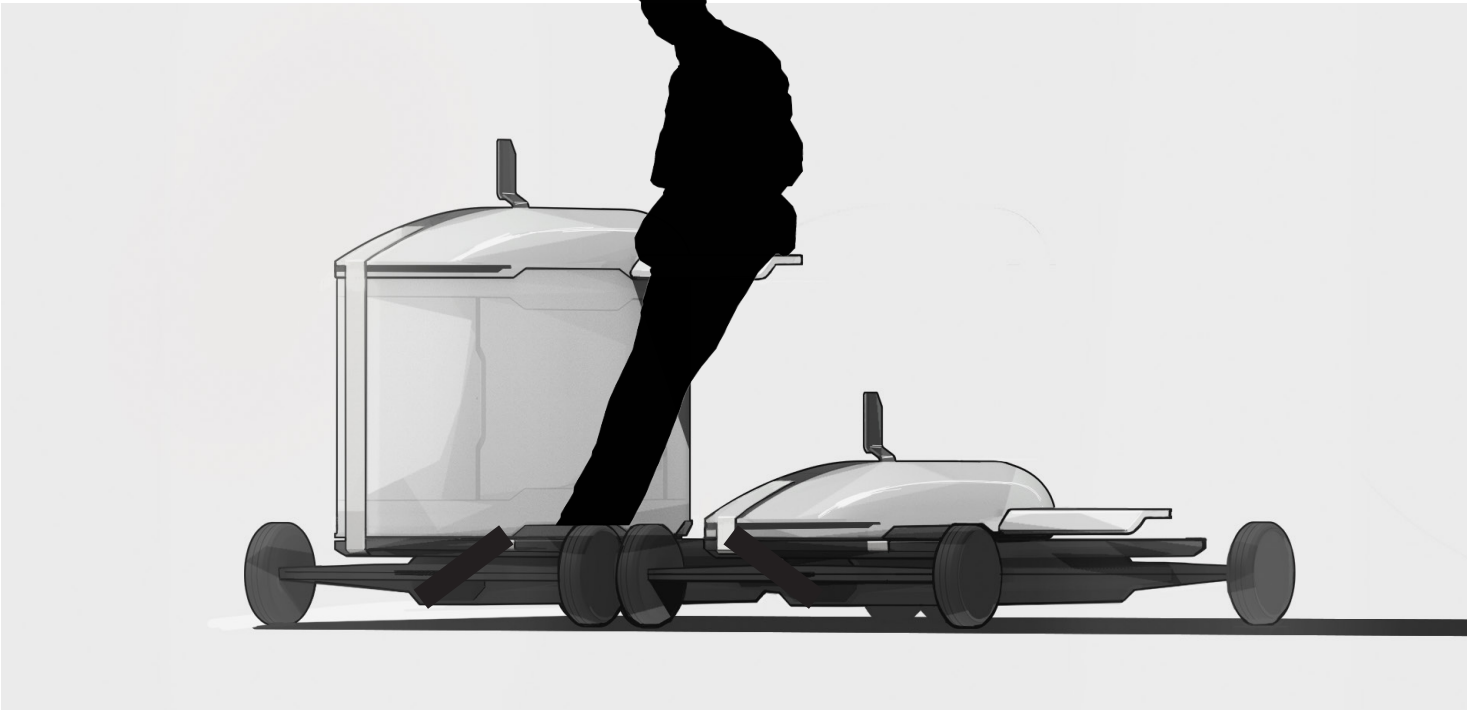
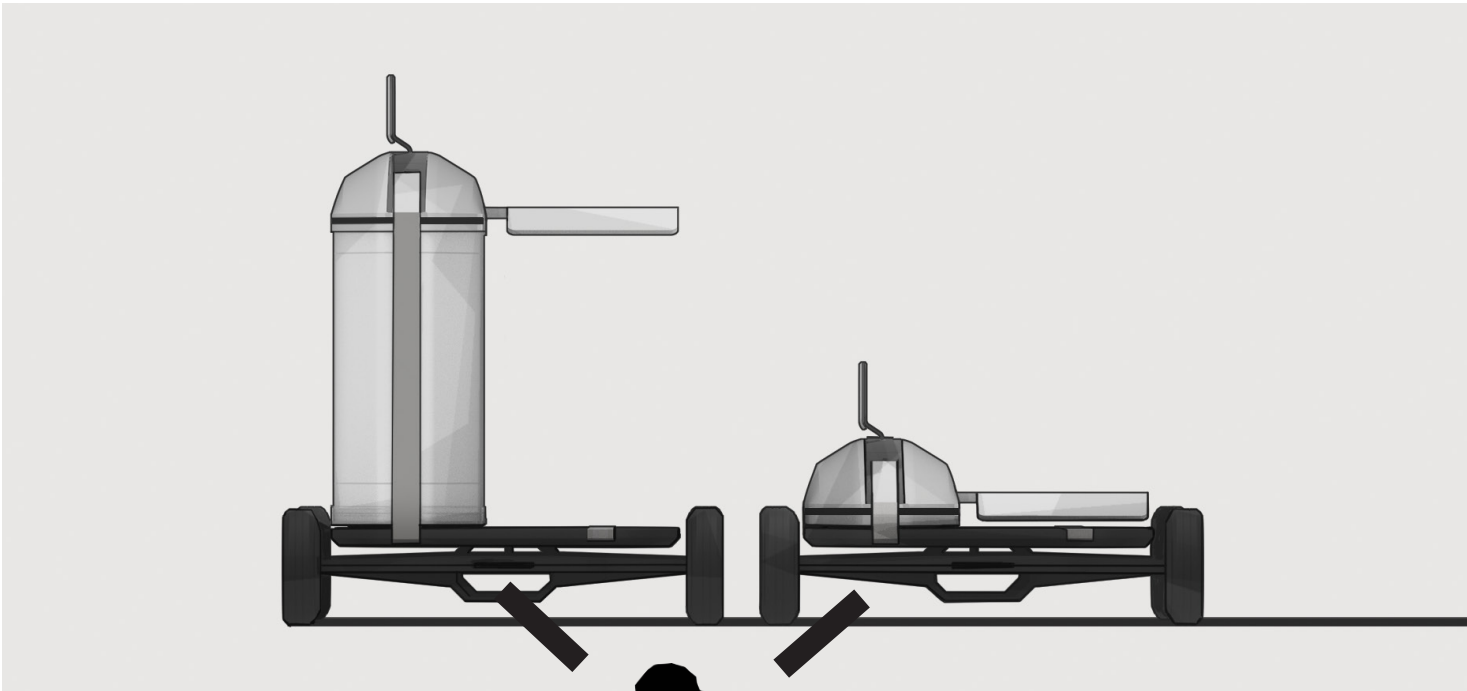

DESIGN DIRECTION

The ideation was narrowed down by discussing the results with the client. The client showed interest in two themes, displayed by key sketches in figure 26 and 27.

In consultation with the client, the second configuration design was chosen for further development. The first configuration theme was rejected, because of the sporty use. This use would exclude people who are not able or skilled enough to drive such a vehicle. Therefore the second configuration theme was chosen for further development.

STYLEPARK

Figure 28 shows the stylepark which was used as inspiration for further development. The stylepark is created based on the desired character; Compact and functional. The stylepark and Audi's product analysis provided direction in the development of volume and surface treatment, materials, splitlines and graphic elements.



DESIGN FREEZE

At a given moment and with the timeframe in mind it is important to establish a design freeze and not to deviate from the main direction. Figure 29 shows the design at the point of the design freeze. Audi's character can be found throughout the whole

design. The form is directly derived from the product's functions and all unnecessary aspects are left out, creating a design that is a fully-fledged Audi. However, the design does inherit its own character supporting the desired interaction with the connected mobility system and therefore fulfilling the project's mission.





Chapter 5

Development

This chapter describes the development from design freeze into the final design, explaining the product's use and features. Topics discussed are the design's dimensions, use, form, technology, materials and colours.

Use & Features

This chapter describes the development of the concept's features. Moreover it provides elaborate explanation of use.

DRIVING MODES

UF35 makes use of three driving modes. The first driving mode (Figure 30, top image) facilitates travel for a single occupant. The design is unfolded, providing cargo space and locking the seat in position.

In the second driving mode UF35 is folded in order to minimize it's size. In this mode it can autonomously pick up users from any location in the city.

The third mode makes use of two cargo crates in order to provide maximum cargo space for autonomous deliveries.

STEERING

When UF35 unfolds, the steering handle will pop out of the top part. The user can autonomously drive to the city. By swiping the touchpad, the vehicle will take a corners in case the user wants to deviate from a predetermined route.

Some parts of the city won't allow for L5 autonomous driving. In this case the user will make use of a "move" button controlled by thumb and and a brake controlled with the index finger.

UF35 needs single hand operation, always leaving one hand free. Making it possible to operate a digital device or hold an umbrella while driving.

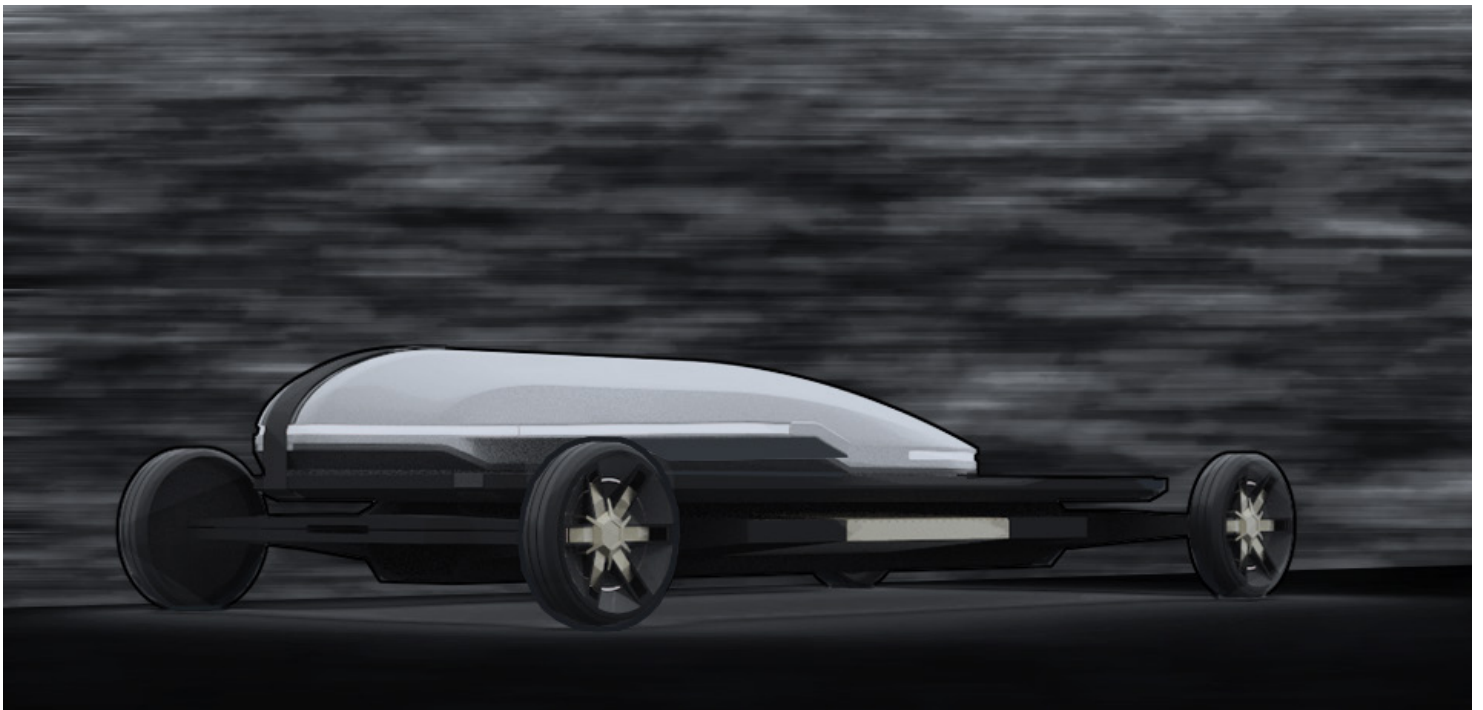

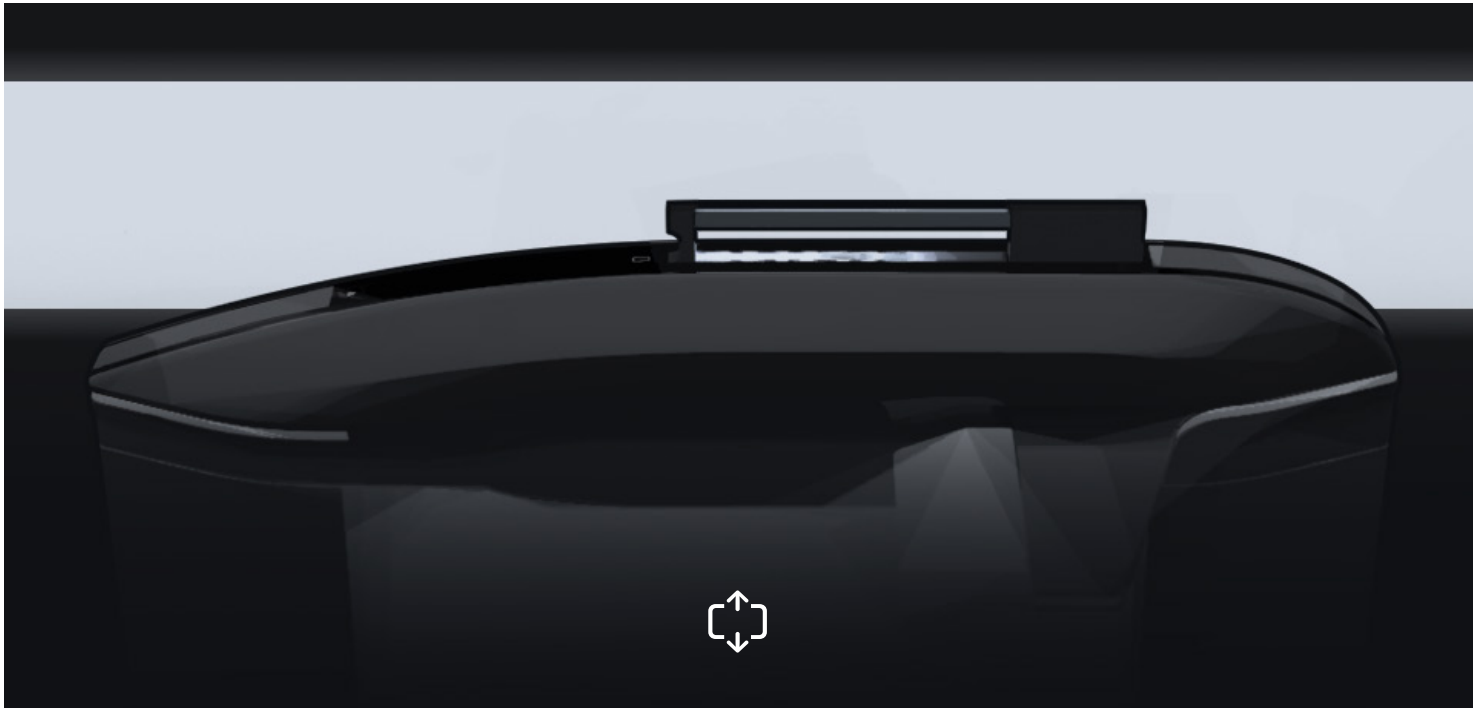

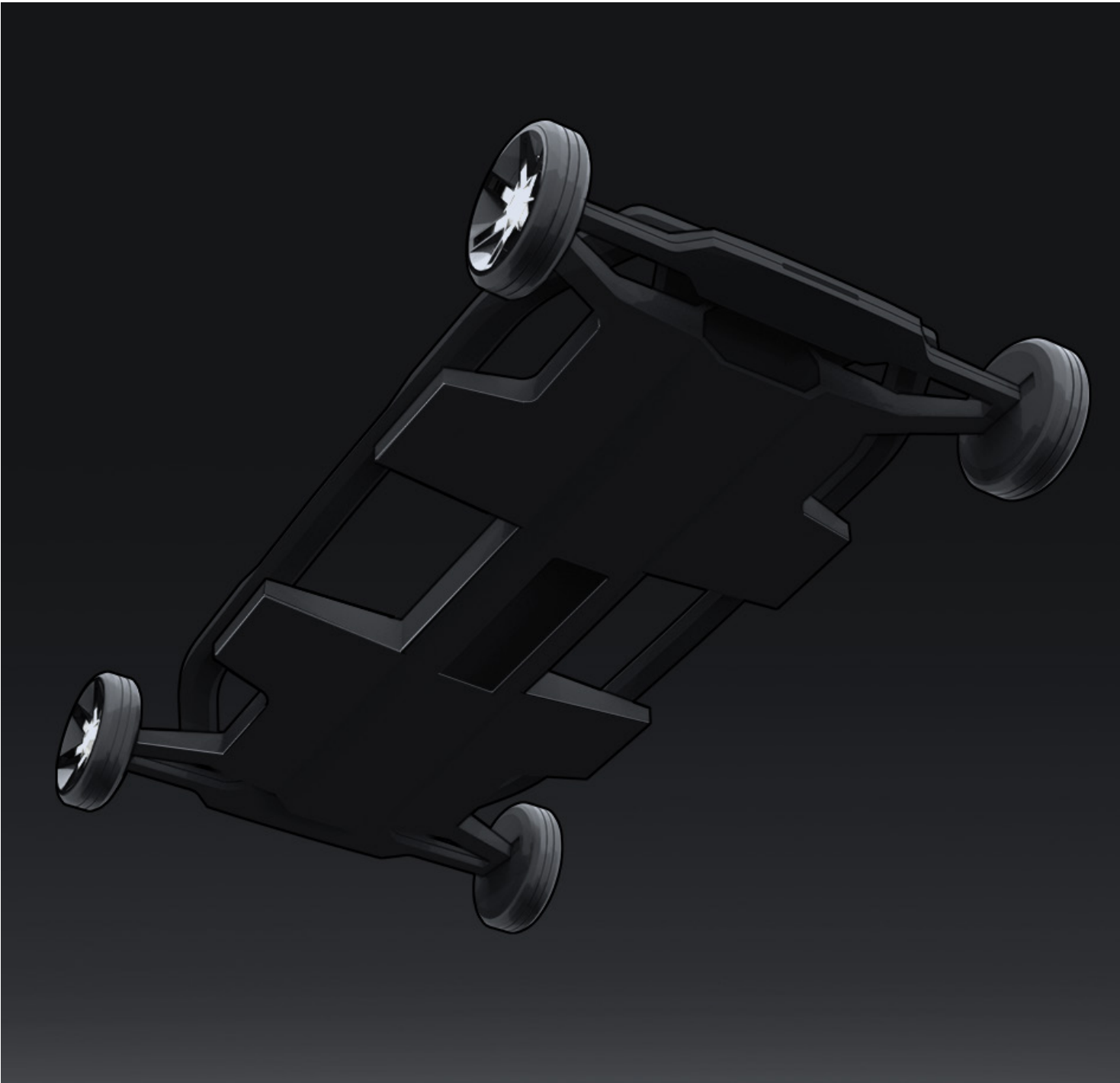



33 UF35 On-Street Parking | Author



34 UF35 Wallmount Parking | Author

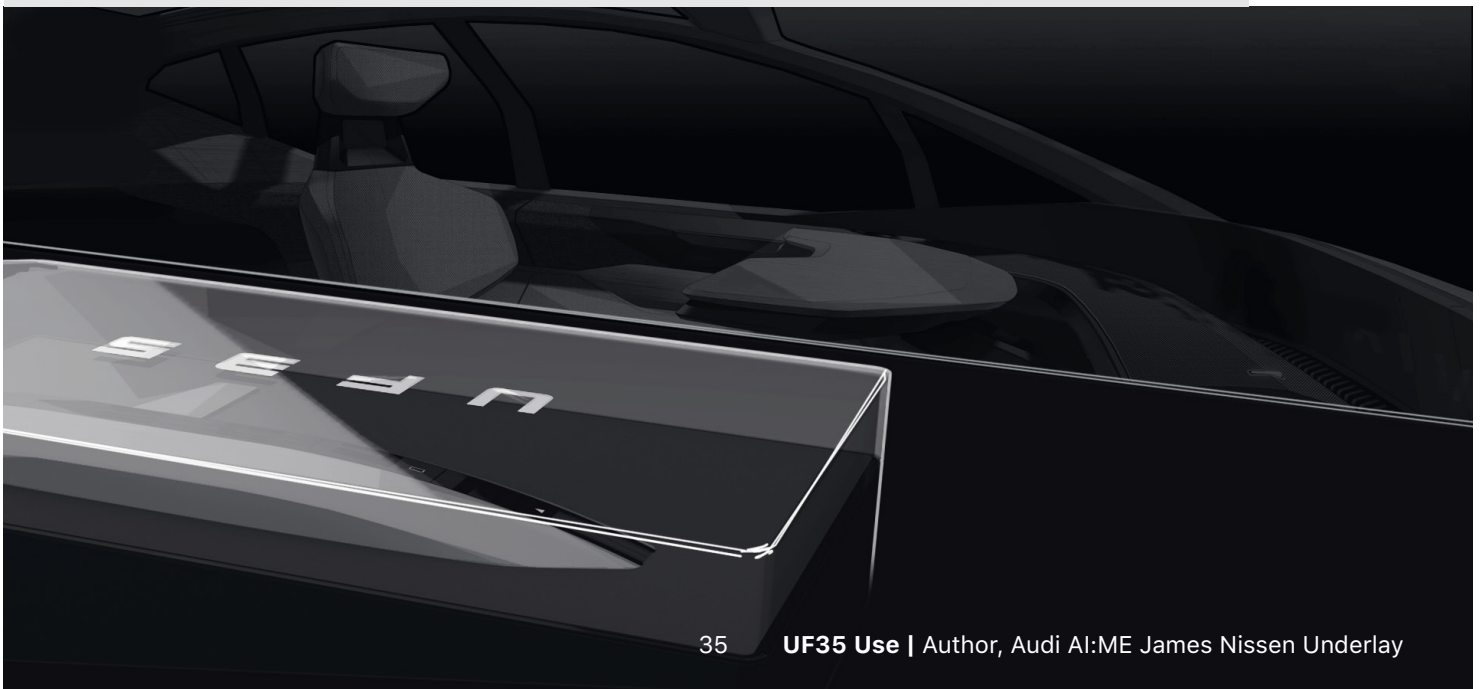

35 UF35 Use | Author, Audi AI:ME James Nissen Underlay

LOADED IN MOBILE HUB

Although the main vehicle is not designed, some guidelines were established. Figure 35 displays how the last-mile EV is loaded in the mobile HUB. The main vehicle will drive L4 autonomously on the main roads and provides room for two occupants. By reserving the right side of the vehicle for the last-mile vehicles, four separate units can be loaded into the mobile HUB. This provides UF35 with the possibility to not only offer two vehicles to the occupants, but to distribute the last-mile vehicles over the city and offer transport on demand. Empty slots can be used to retrieve unused EV's and autonomously remove them from pedestrian areas to avoid taking up street parking space. This ensures a mutual beneficial relationship between this concept and the city.

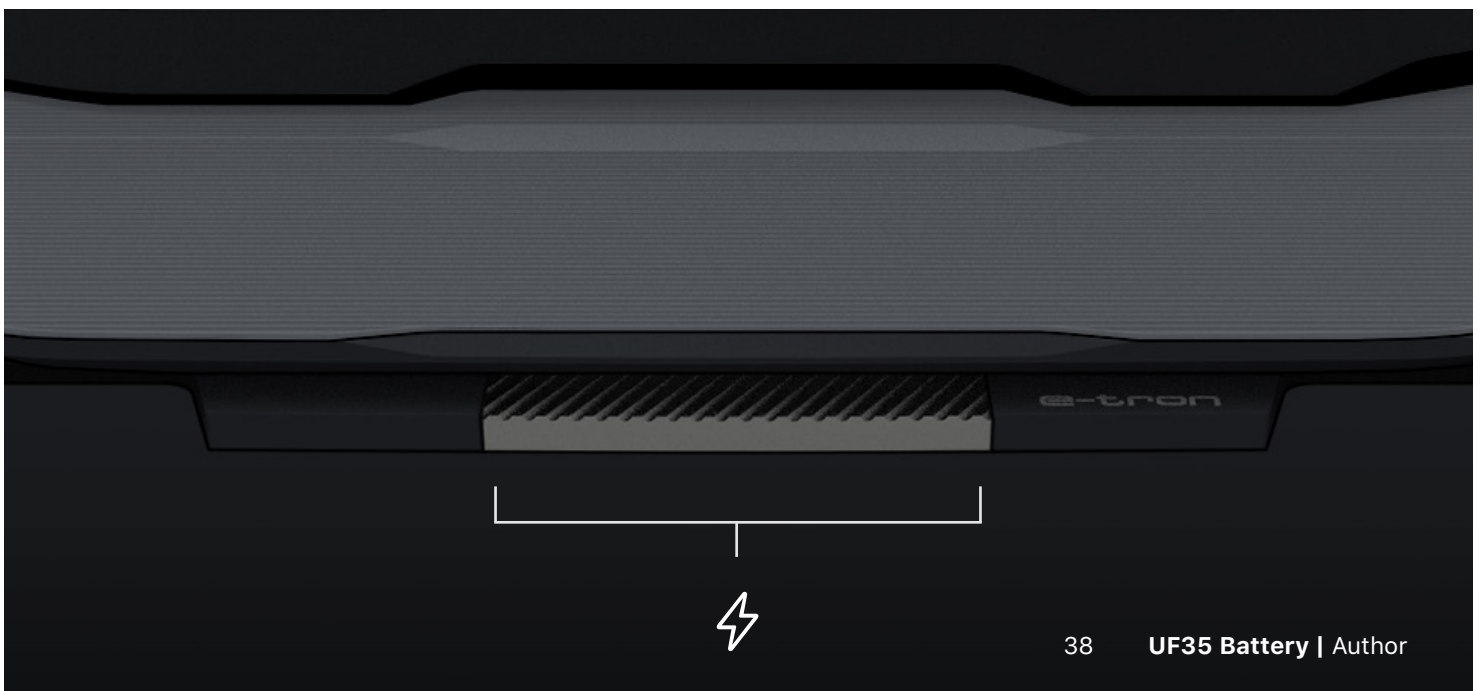
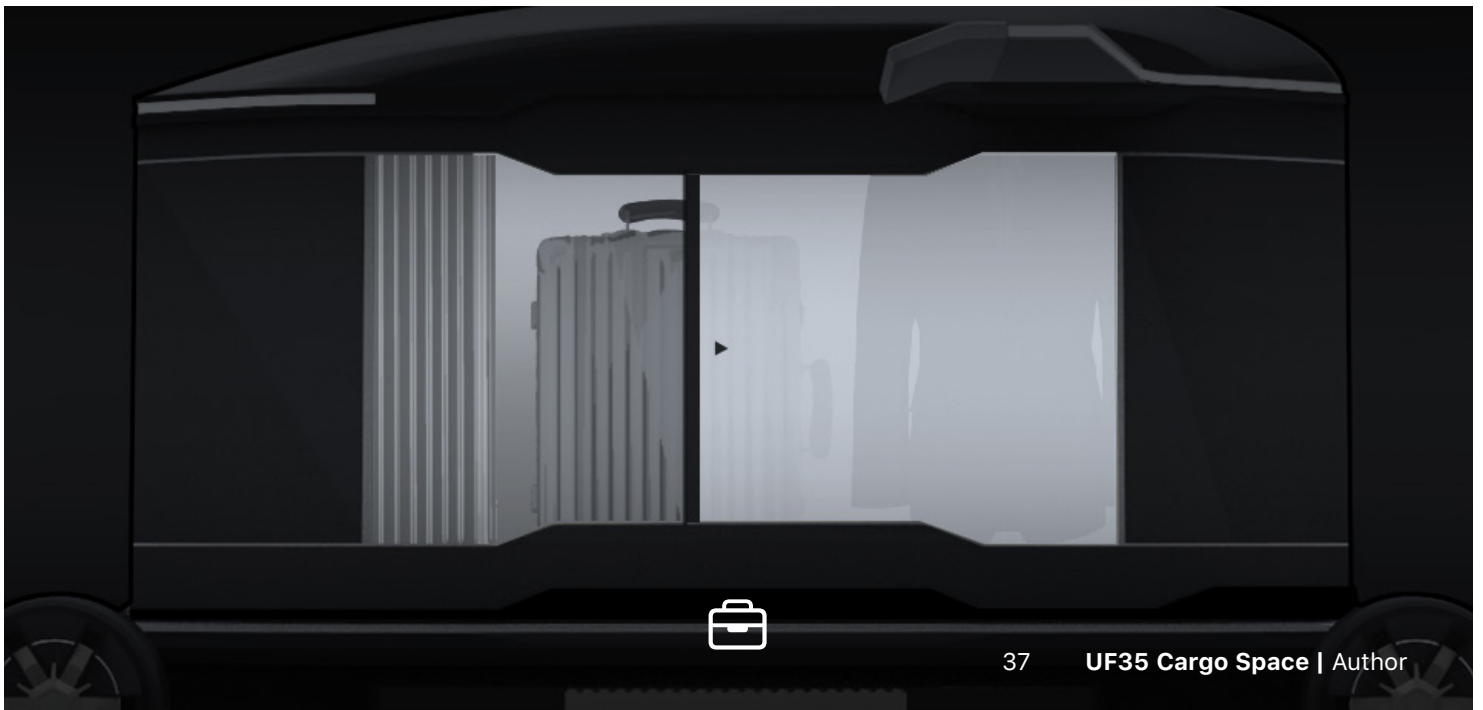

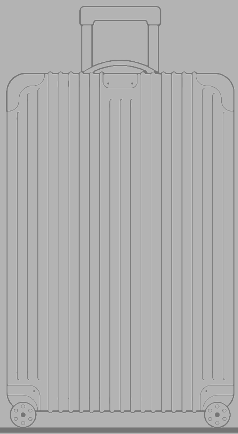

+

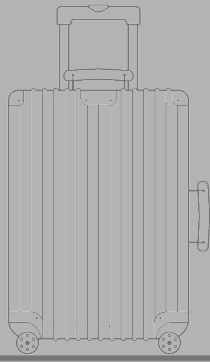

+

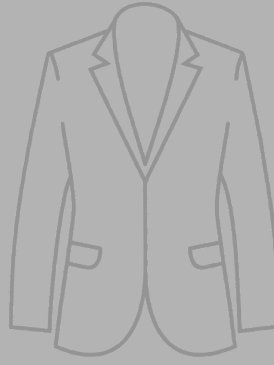

+

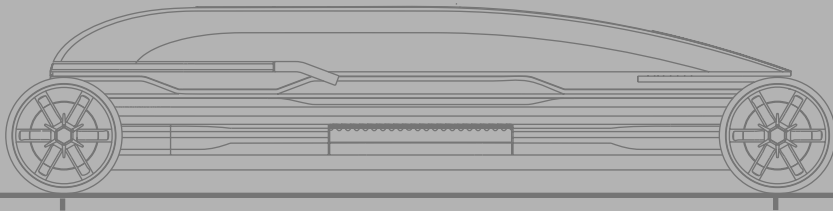

195 cm

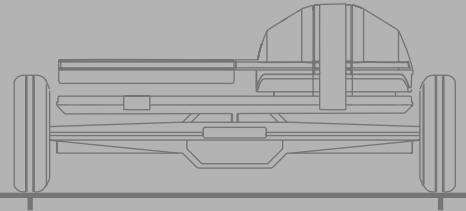

105 cm

45 cm

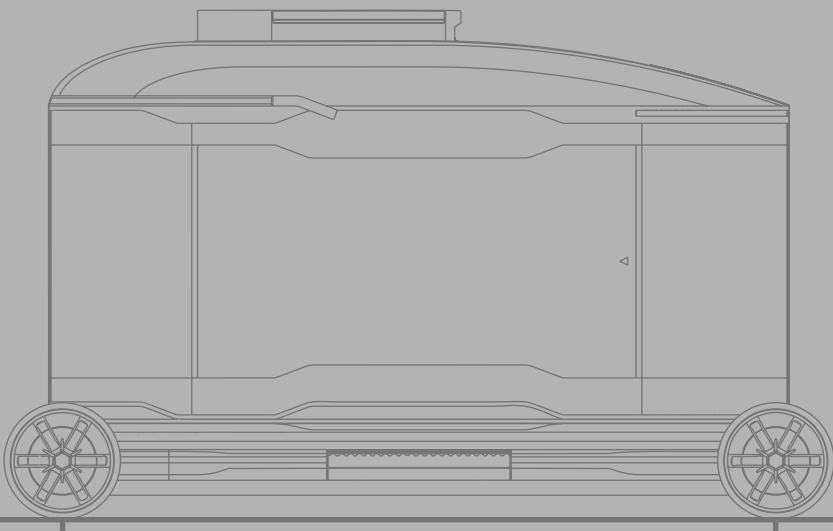
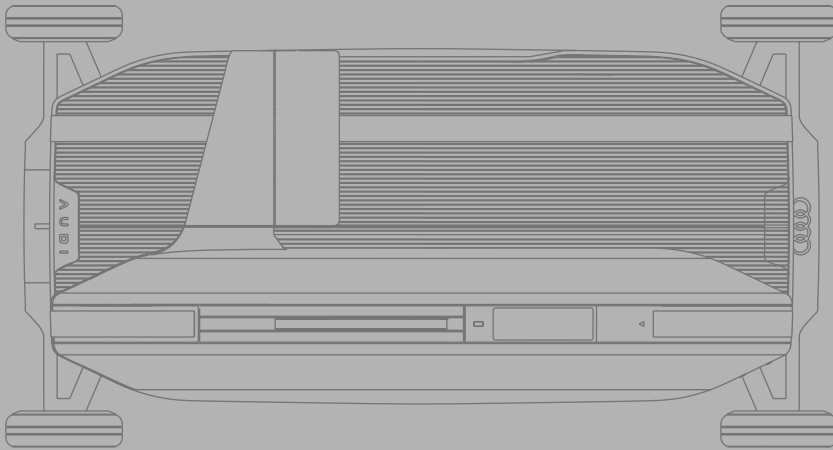

195 cm

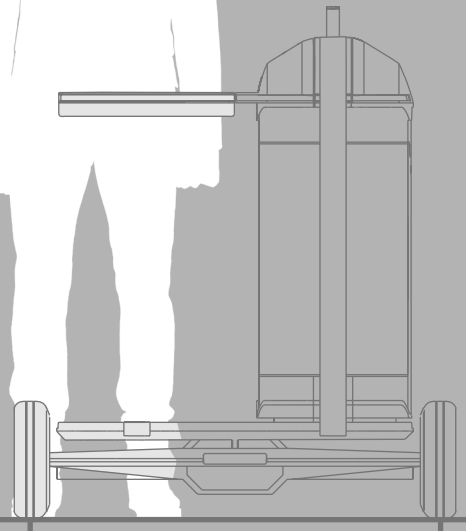

105 cm

120 cm

5.2

Material & Colour

In order to facilitate an unobstructive and fresh appearance that fit to the brand and character, it was decided to make use of warm grey tones.

By visually separating the top part from the fabric the product becomes optically lighter, enhancing visual unobstructiveness. The product offers a subtle and neutral platform on which users are able to differentiate from each other by the clothes they are wearing.

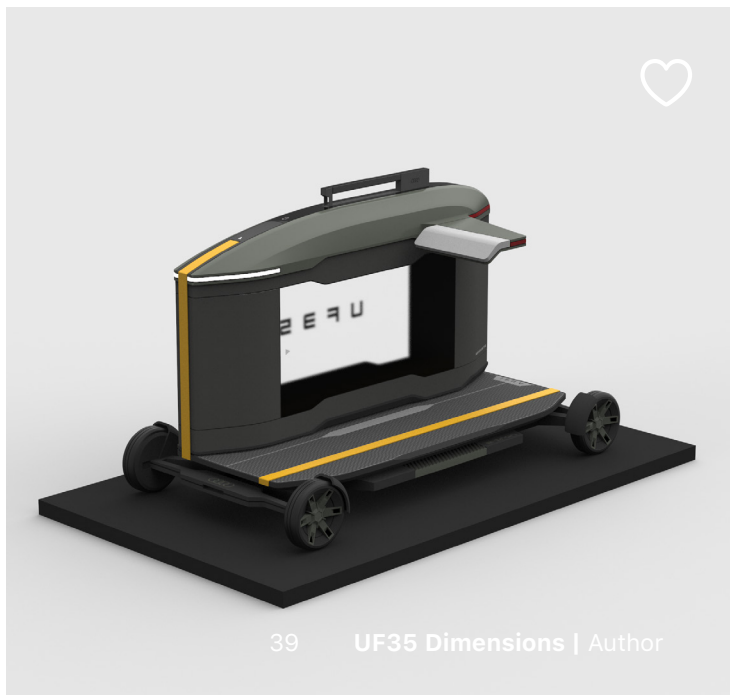
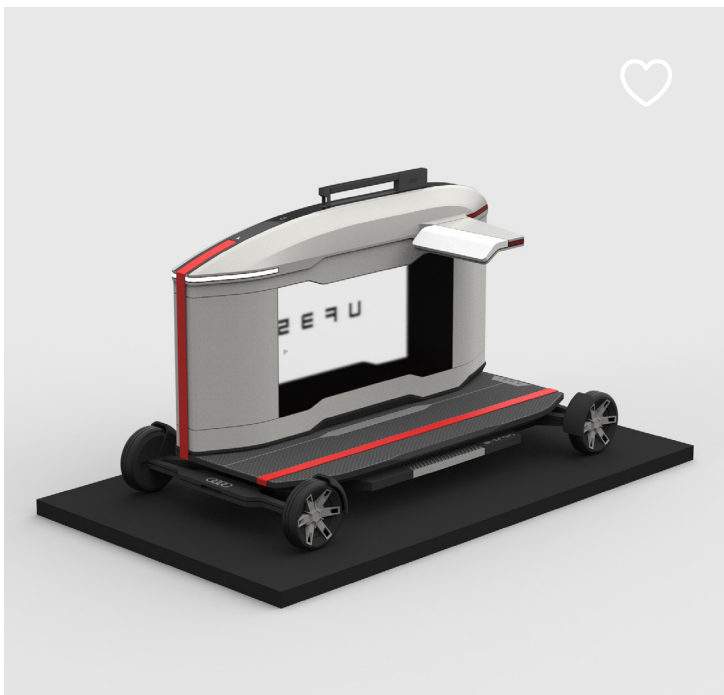
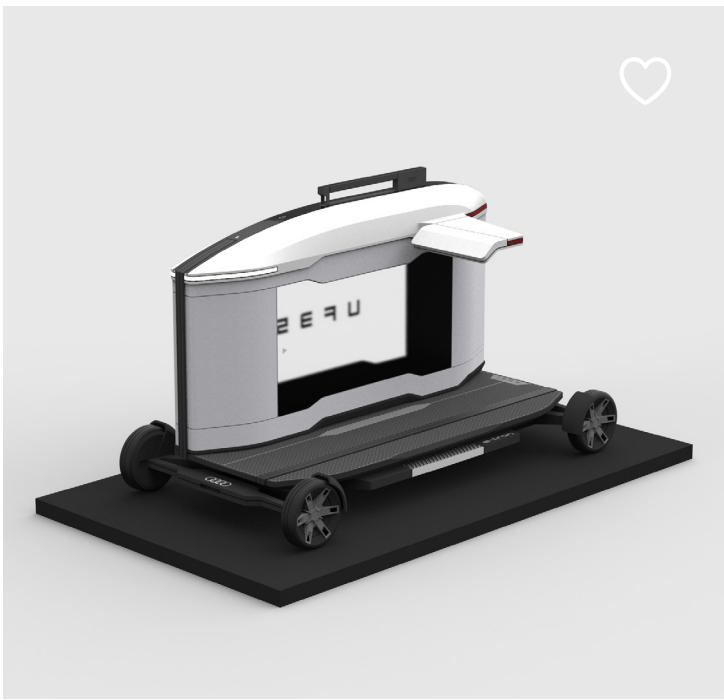



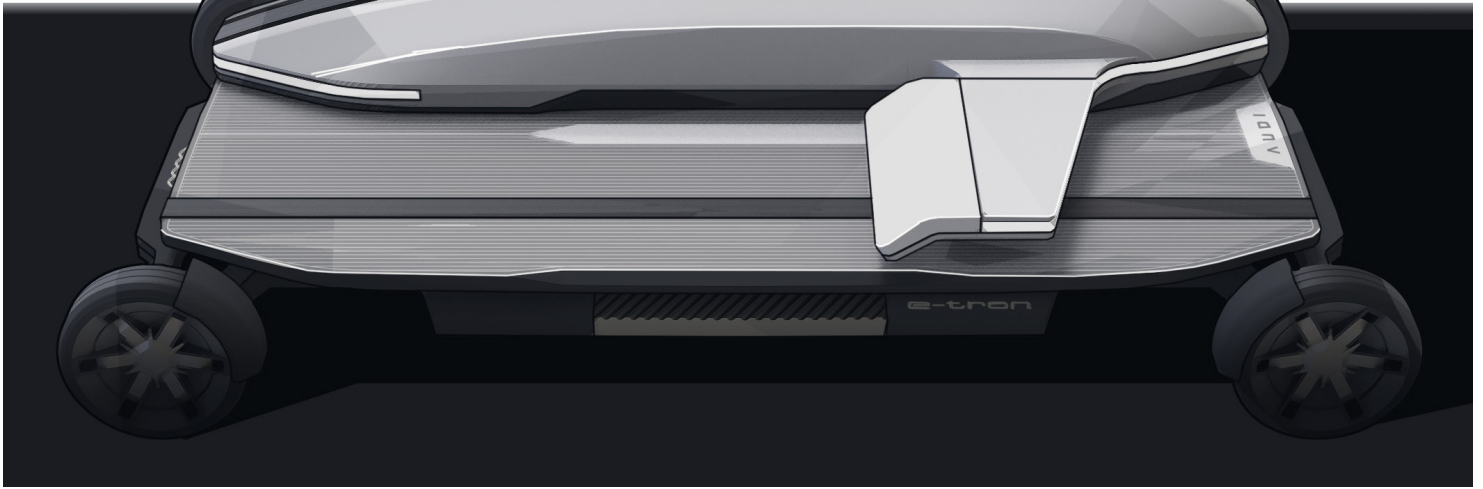



1. ANALYSIS



Audi



Shared Mobility



Context



Synthesis



2. VISION



Mission



Interaction



Product Qualities



Design Input



3. DESIGN



Configuration



Ideation



Design Themes



Design Freeze



4. DEVELOPMENT



Use



Form



Technology



Final Design

Chapter 6

Final Design

This chapter presents the final design.

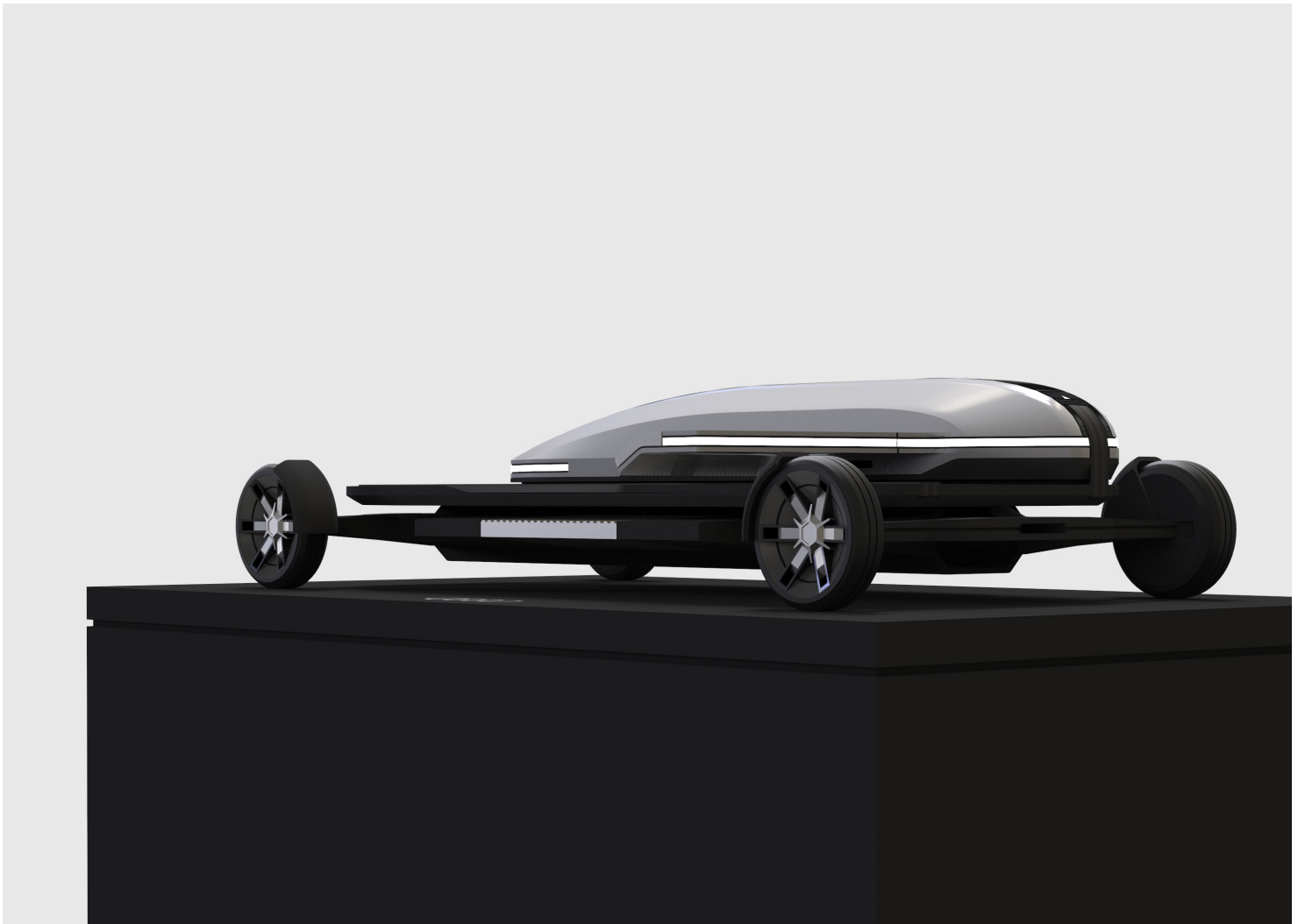
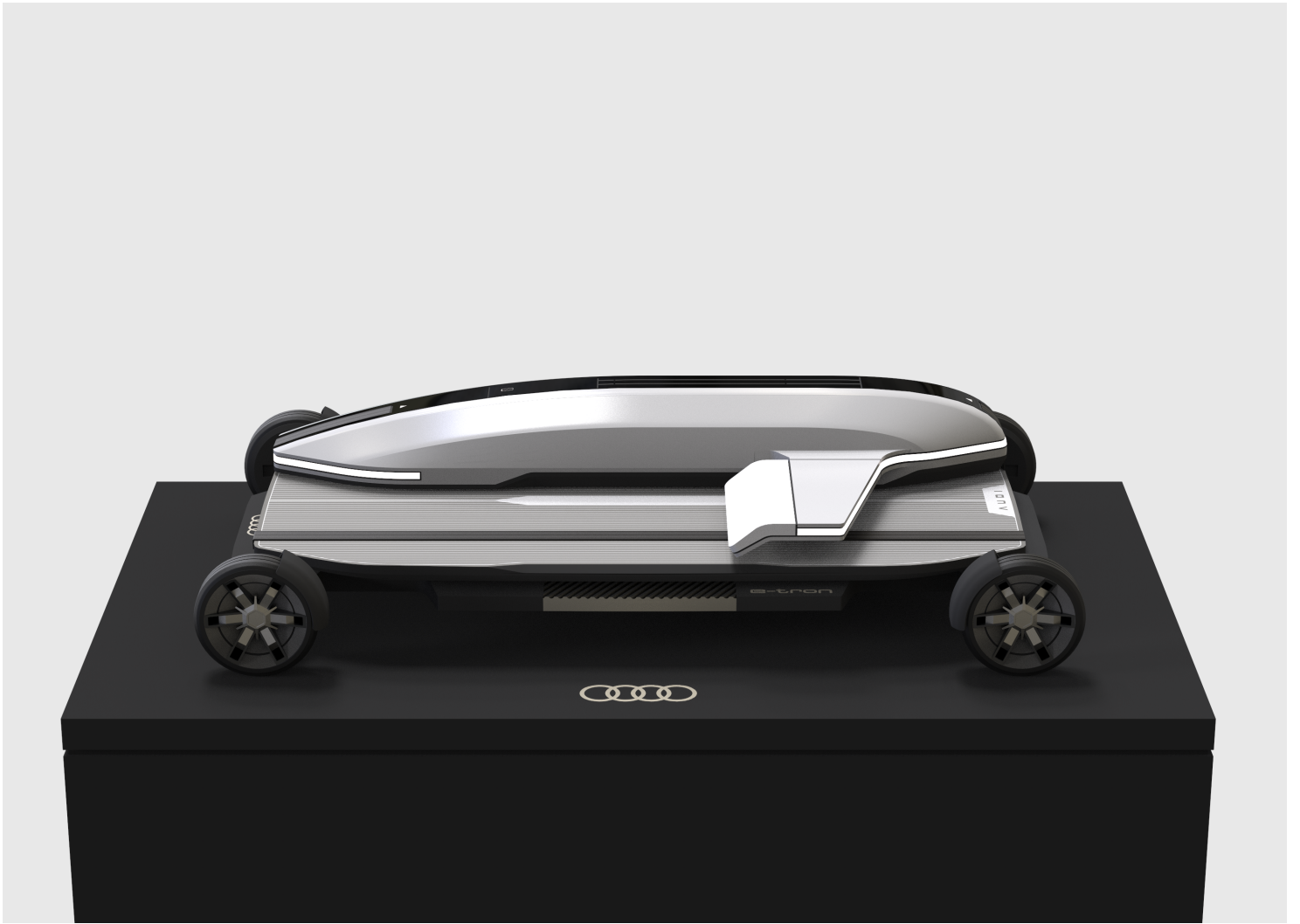







Discussion

This chapter describes the role and background of the partners involved in this project. Furthermore, it elaborates the project goals, the design topic and gives an overview of the design approach.

Recommendations

In the industry it takes a car company around 3 to 4 years to develop a vehicle from the first sketch into a production-ready product. This graduation project is individually executed over a period of 7 months. Therefore, the final design is not a production-ready vehicle. This section describes recommendations for further research and development.

Linework and Surfaces

Figure 44 displays how the linework could be improved in the final design. The linework in the front and rear of the vehicle's top part appears convex from certain points of view, where it would be more desirable to have more concave linework. The surfaces in the top part don't run as smoothly as desired. Since there was not enough budget in this project to obtain support from 3D-modellers, the surfaces didn't reach an A-class quality.

Audi Logo Visibility

Audi takes care that the logo is always completely visible from all sides of the vehicle and is never visually obstructed. Making use of logos on the front, rear and sides of the car, Audi makes sure that this is achieved. In the case of the UF35, the logo is cut and not fully visible from all sides. For further development it is recommended to revise the placement of logo's and graphics.

Internal Mechanisms

Figure 44 displays the fabric sliding horizontally along a slider placed in the crate's top part. Because of the multiple angles in the fabric's design, a simple horizontal slider mechanism

won't suffice. The internal mechanism to unfold the cargo area isn't fully developed. Figure 44 shows how the movement of the mechanism is intended. Although it could be feasible, it should be further investigated how this mechanism works and if it doesn't obstruct the practical use of the product. To make sure that the cargo doesn't slide in the cargo area, a certain fixing mechanism could be integrated. This fixation could be established by using straps.

Ergonomics

It is recommended to test the steering handle on ergonomic properties. Although the dimensions of the handle are designed based on human data, the sharp angles could be uncomfortable in use. The seat isn't equipped with lateral support. This could create situations where the user will slide sideways of the seat when taking corners.

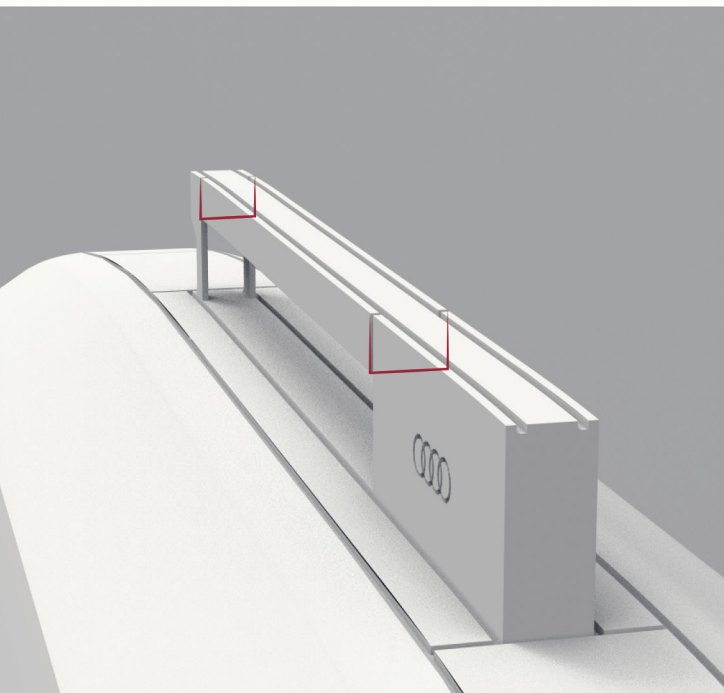
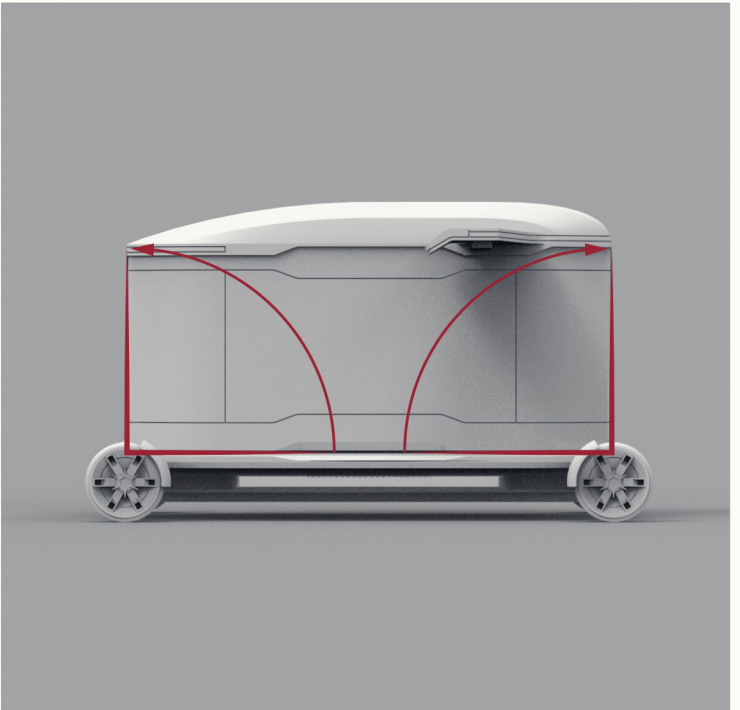
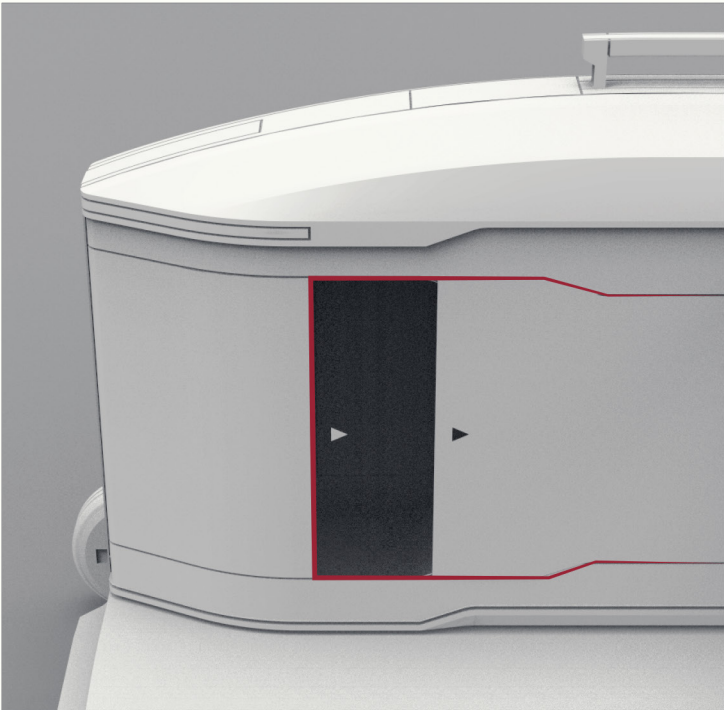
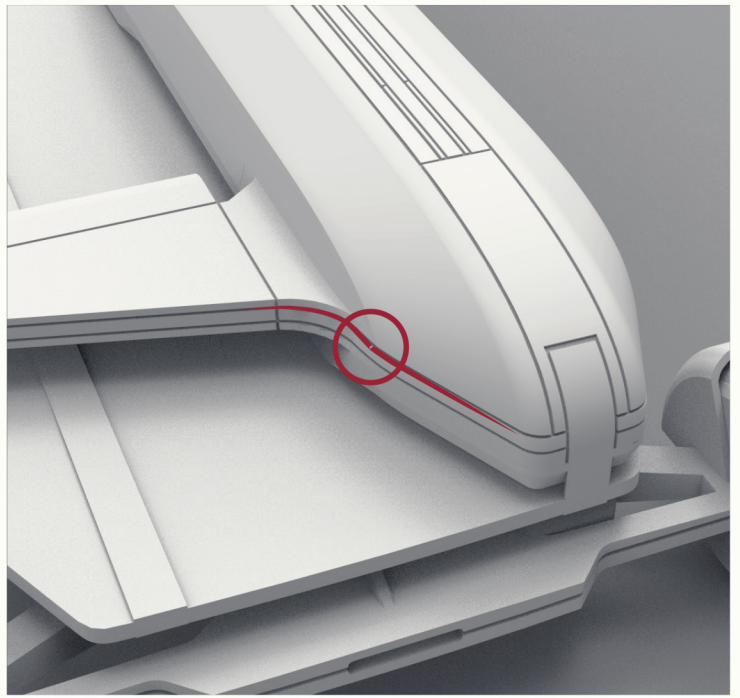
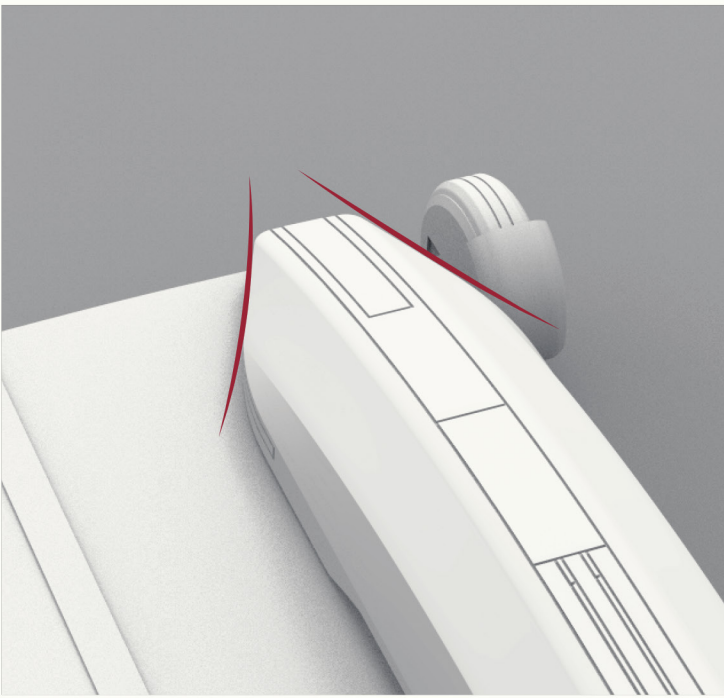

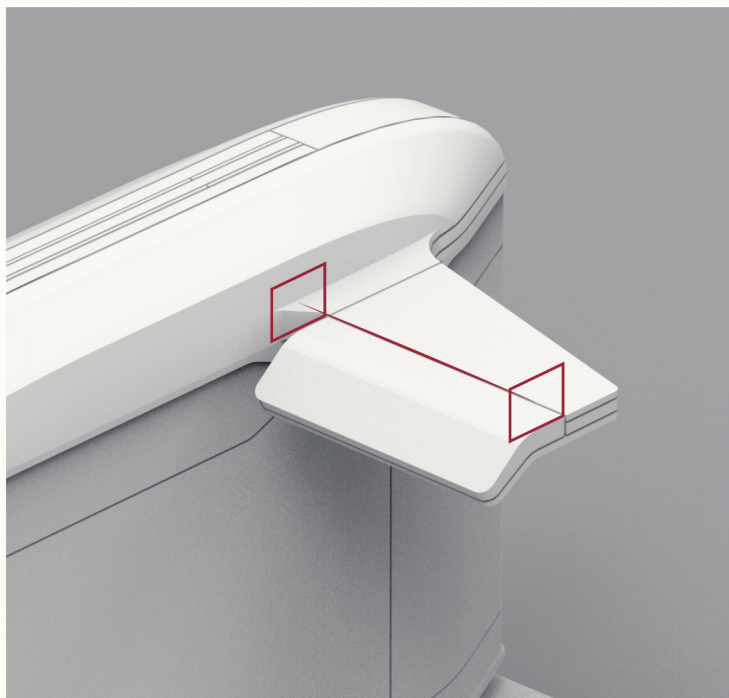
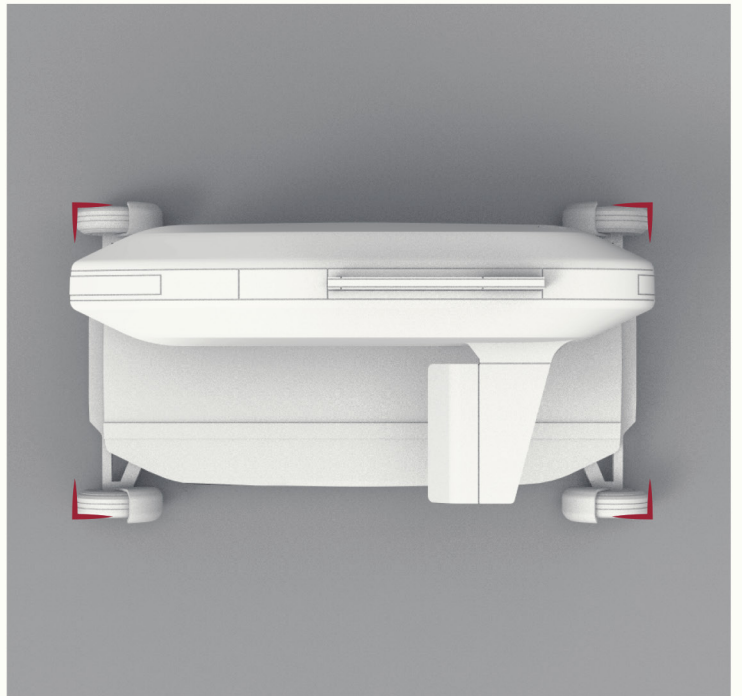
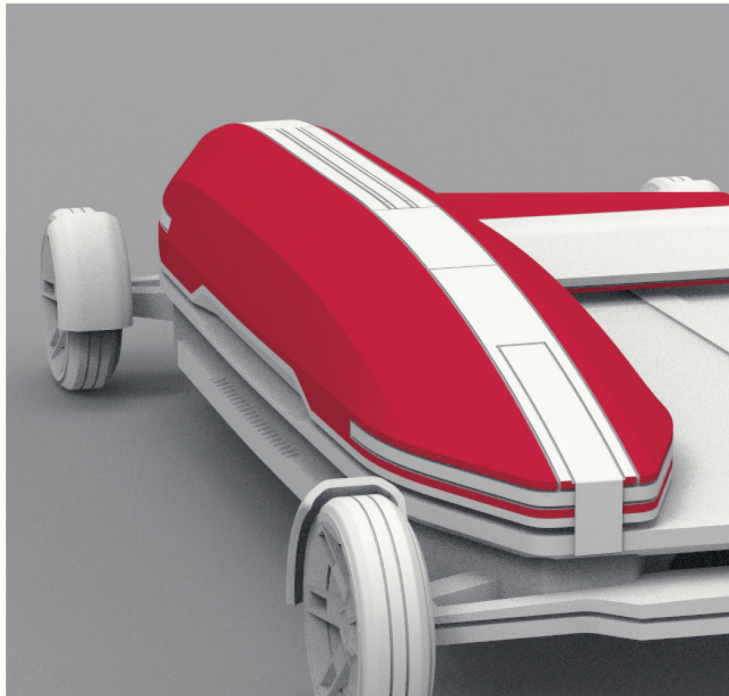
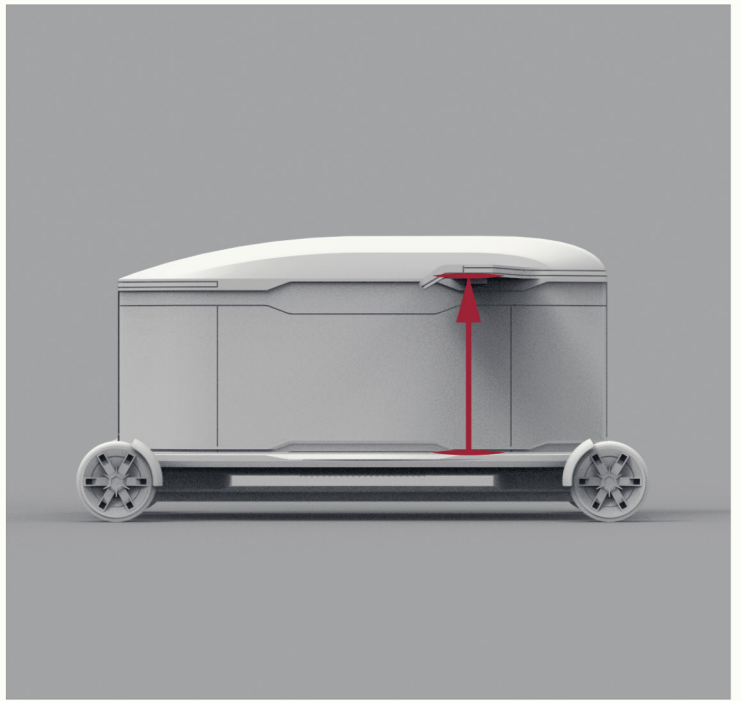
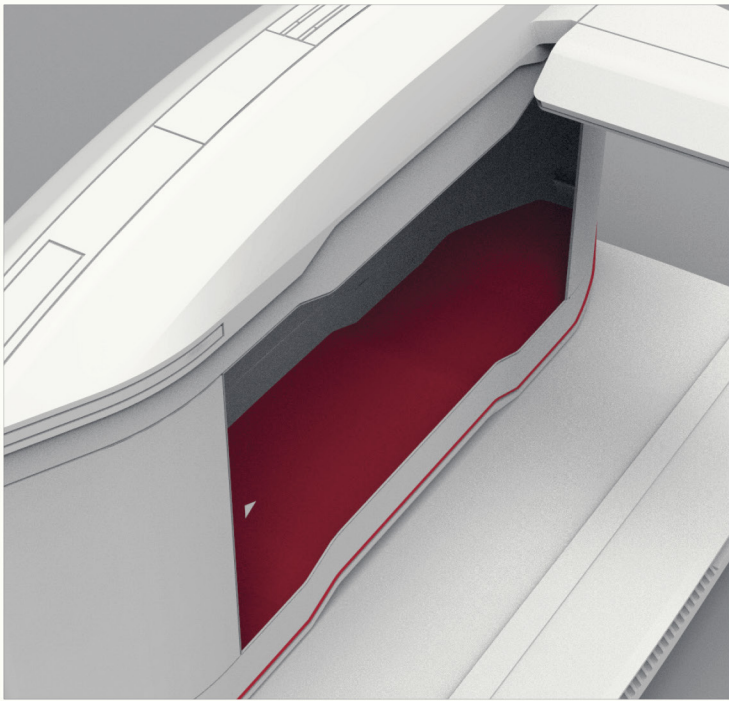

Usability

To facilitate comfortable use for a P5 female and P95 male, the seat's height should be adjustable. The height of UF35's seat can be adjusted by lowering the complete top part, which the seat is connected to. This might not be the most effective solution while it reduces the size of the cargo area. The UF35 is in this form not able to drive on stairs. Neither will it be light enough for a person to carry it on stairs. To implement use-cases in which stairs have to be surpassed, the design has to be adjusted.

Project Evaluation

The expectations from the TU Delft university and the automotive industry related to this project differ in the way they view the design process and results.

The university requires you to maintain a holistic approach, which prioritizes a structured process and detailed process towards achieving the end goal. This offers a solid basis to arrive at feasible and logical results, as well as offering a large scope of the challenge at hand.

Within the automotive industry the analysis of the design challenge is for a large part left to other departments. As a result, the role of designer is to execute the project on the basis of this information. This results in more specified creative challenge, in which the designer has more time to cast a wide net in terms of solutions. This makes it possible to arrive at results which would be beyond the creative scope in a more restricted process.

While carrying out this project the differences in approach were apparent at every step. The wider contextual approach of the university was often at odds with the specialized approach used within Audi. As a result, the two parties required vastly different deliverables along the timeline of the project. This gave the impression of

managing multiple projects at once, due to having to satisfy both sides of the conceptual process simultaneously.

This has offered a valuable lesson in combining the interests and requirements of different parties within one project. In my case I felt that both schools of thought provided a valuable addition to each other. The structured and full scope mentality the TU Delft has taught me has allowed me to embrace the specialized and open approach the automotive industry has to offer. My goal is continue combining the positive sides of the different approaches I encounter, as I believe being able to continually adapt to new challenges hold the key to being successful in the automotive industry.

Personal Reflection

In this section I reflect upon my own skills and attributes based on this project. I do so in order to identify where I have room to improve myself and to obtain better results in future projects.

Perfectionism

Having certain perfectionistic tendencies has influenced my work in both positive and negative ways. On the positive side it helped me sharpen my attention for detail and pay attention to even the smallest aspects of design.

On the negative side it has also influenced how I communicate with my peers. When I do not consider my work to be up to my high standards, sharing it and asking for feedback becomes more difficult. This can withhold me from effectively communicating while working on a project.

The process in which assignments are presented within the design industry suited my creative vision very well. I could express my creative freedom in the set timeframe. I struggled in the transition back into a full-time academical approach. My design brief was not a solid enough basis to complete my work and as a result a lot of my time was lost on articulating matters that should have been completed at that point.

Z

Bibliography

Arbib, J., & Seba, T. Rethinking transportation 2020-2030.

AUDI AG. (2018). Retrieved 26 April 2019, from <https://www.audi.com/en/company/history.html>

AUDI AG. (2018). Retrieved 26 August 2019, from <https://www.audi.com/en/company/strategy/corporate-strategy-explanation.html>

Deloitte. (2019). Retrieved 14 April 2019, from <https://www2.deloitte.com/us/en/insights/economy/issues-by-the-numbers/understanding-millennials-generational-differences.html>

Audi Encounter. (2018). Retrieved 26 April 2019, from <https://audi-encounter.com/en/design>

BCN. 2010. Retrieved 14 April 2019, from <http://www.bcnecologia.net/en/conceptual-model/superblocks>

Hamari et al. 2016. The Sharing Economy: Why People Participate in Collaborative Consumption

Hekkert, P., & Dijk, M. (2011). Vision in design. Amsterdam: BIS.

LSE Cities. (2019). Retrieved 6 May 2019, from <https://lsecities.net/wp-content/uploads/2015/09/New-Urban-Mobility-London-and-Berlin.pdf>

Martin, G. (2019). 'Vorsprung Durch Technik' - the meaning and origin of this phrase. Retrieved 14 April 2019, from <https://www.phrases.org.uk/meanings/vorsprung-durch-technik.html>

McKinsey. (2019). Retrieved 6 May 2019, from <https://www.mckinsey.com/industries/automotive-and-assembly/our-insights/how-shared-mobility-will-change-the-automotive-industry>

McKinsey. (2019). Retrieved 29 May 2019, from <https://www.mckinsey.com/~media/mckinsey/industries/high%20tech/our%20insights/disruptive%20trends%20that%20will%20transform%20the%20auto%20industry/auto%202030%20report%20jan%202016.ashx>

MaaS Alliance. 2018. Retrieved 6 May 2019, from <https://maas-alliance.eu>

Machado, C. & de Salles Hue, N. & Berrsaneti, F. & Quintanilha, J. (2018). An Overview of Shared Mobility.

Sustainability. 10. 4342. 10.3390/su10124342.

Pojani, D.; Stead, D. The urban transport crisis in emerging economies: An Introduction. In *The Urban Transport Crisis in Emerging Economies*; Springer: Cham, Switzerland, 2017; pp. 1–10.

Phrases. (2019). Retrieved on 8 May 2019 from <https://www.phrases.org.uk/meanings/vorsprung-durch-technik.html>

Pojani, D.; Stead, D. (2017). The urban transport crisis in emerging economies: An Introduction. In *The Urban Transport Crisis in Emerging Economies*; Springer: Cham, Switzerland, 2017; pp. 1–10

Rice-Oxley, M. (2012, September 18). Vorsprung durch Technik – ad slogan that changed how we saw Germany. Retrieved 6 May 2019, from <http://www.theguardian.com/world/2012/sep/18/vorsprung-durch-technik-advertising-germany>

Roland Berger. (2019). Retrieved 6 May

2019, from <https://www.rolandberger.com/en/Media/Purpose-built-vehicles-for-ride-sharing-services-Global-demand-to-rise-to-2.5-m.html>

SAE International. (2018).

Retrieved 6 May 2019, from <http://innovativemobility.org/?project=sae-international-publishes-set-of-definitions-for-shared-mobility-terms>

Strategy | audi.com. (2019). Retrieved 6 May 2019, from <https://www.audi.com/en/company/strategy.html>

Schaefers, T. Exploring carsharing usage motives: A hierarchical means-end chain analysis. *Transp. Res. Part A Policy Pract.* 2013, 47, 69–77.

TU Delft. (2019). Retrieved 14 April 2019, from <https://www.tudelft.nl/onderwijs/opleidingen/masters/ipd/msc-integrated-product-design/>

UN DESA. (2019) Retrieved 6 May 2019, from <https://www.un.org/development/desa/en/news/population/2018-revision-of-world-urbanization-prospects.html>

Volkswagen AG. (2018). Retrieved 14 April 2019, from <https://annualreport2018.volkswagenag.com/divisions/audi.html>

