

FLOATING FOR HEALTH

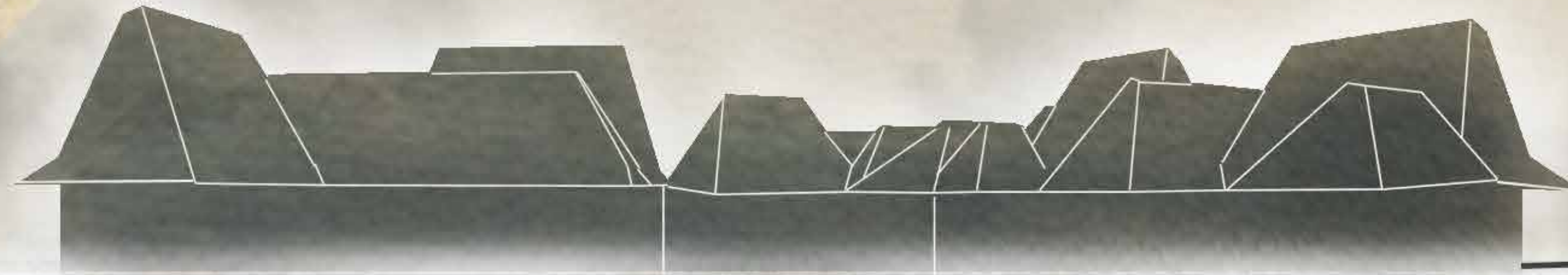

Bas de Pater
Graduation Presentation
06/11/2018

INTRODUCTION

INTRODUCTION

Overview

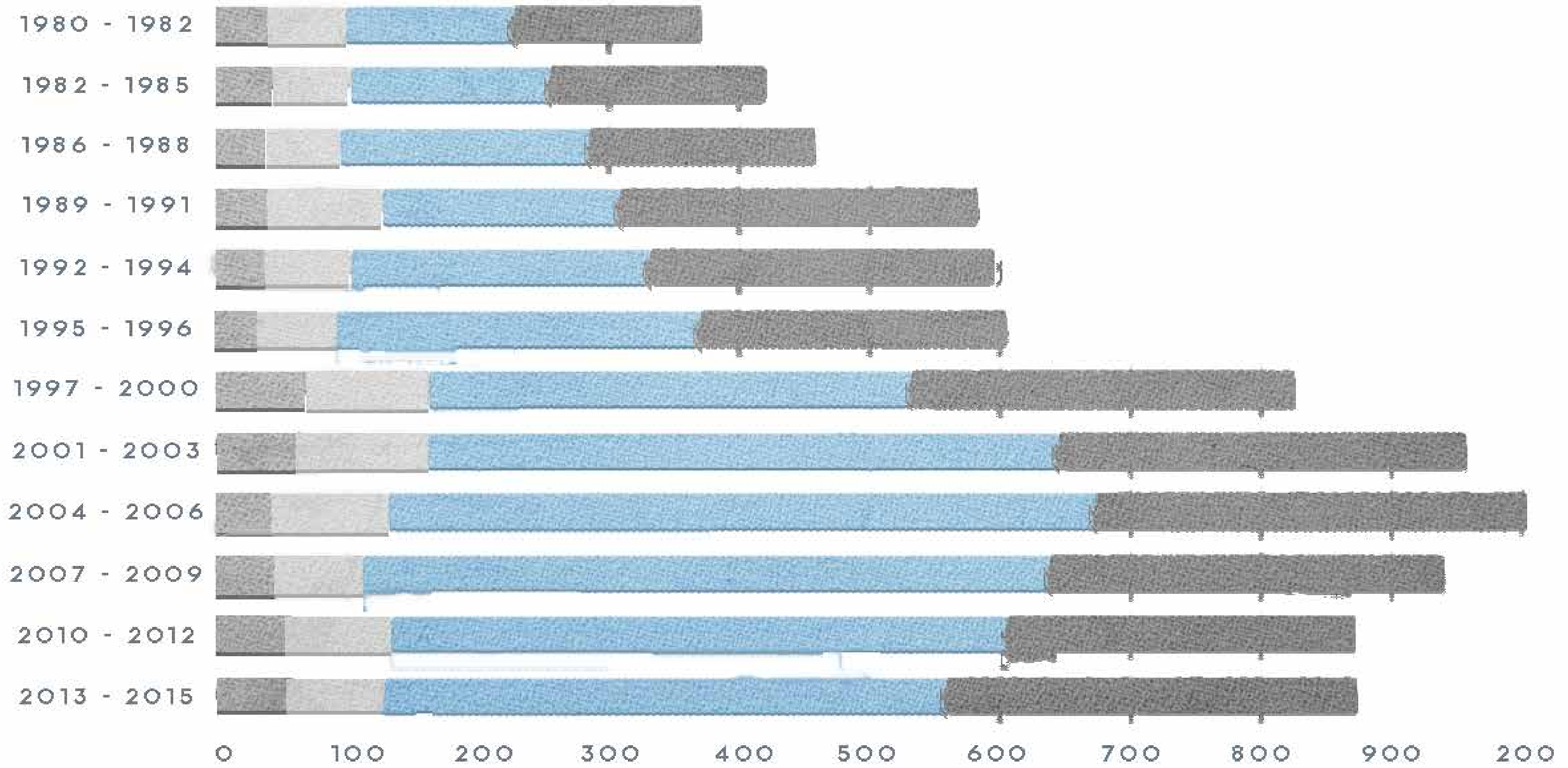

DROUGHT



EARTHQUAKE

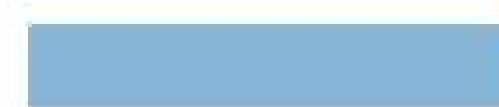

FLOODING



STORM

NATURAL DISASTERS REPORTED

INTRODUCTION

Overview

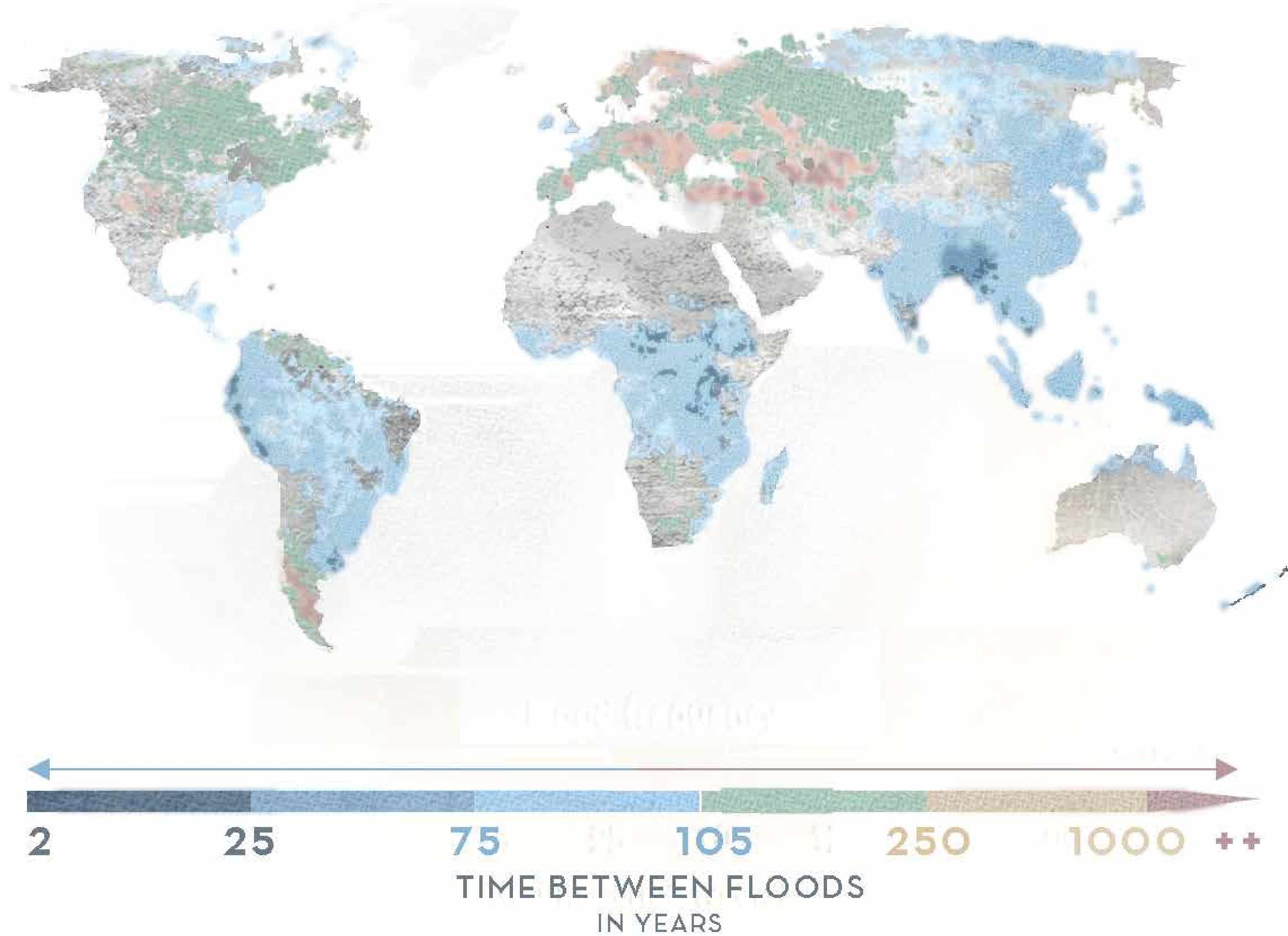

INTRODUCTION

Overview

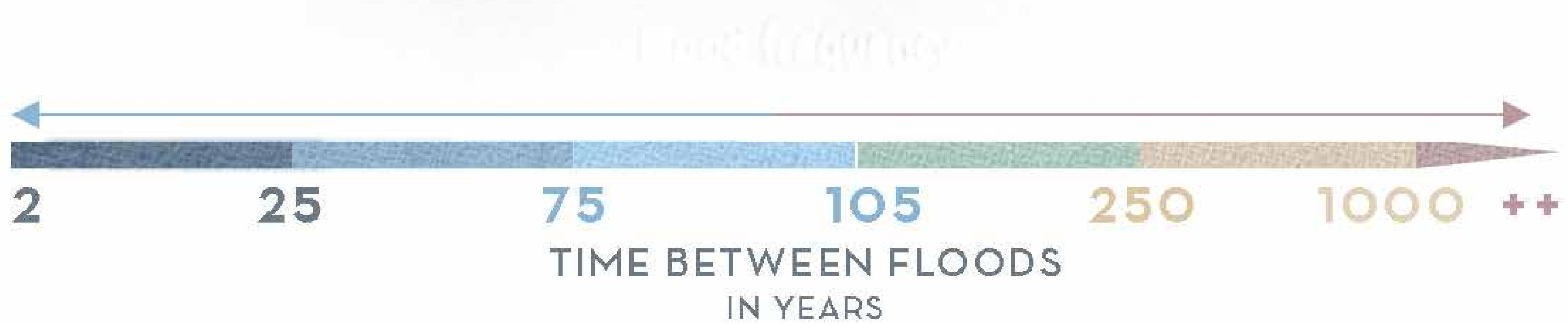
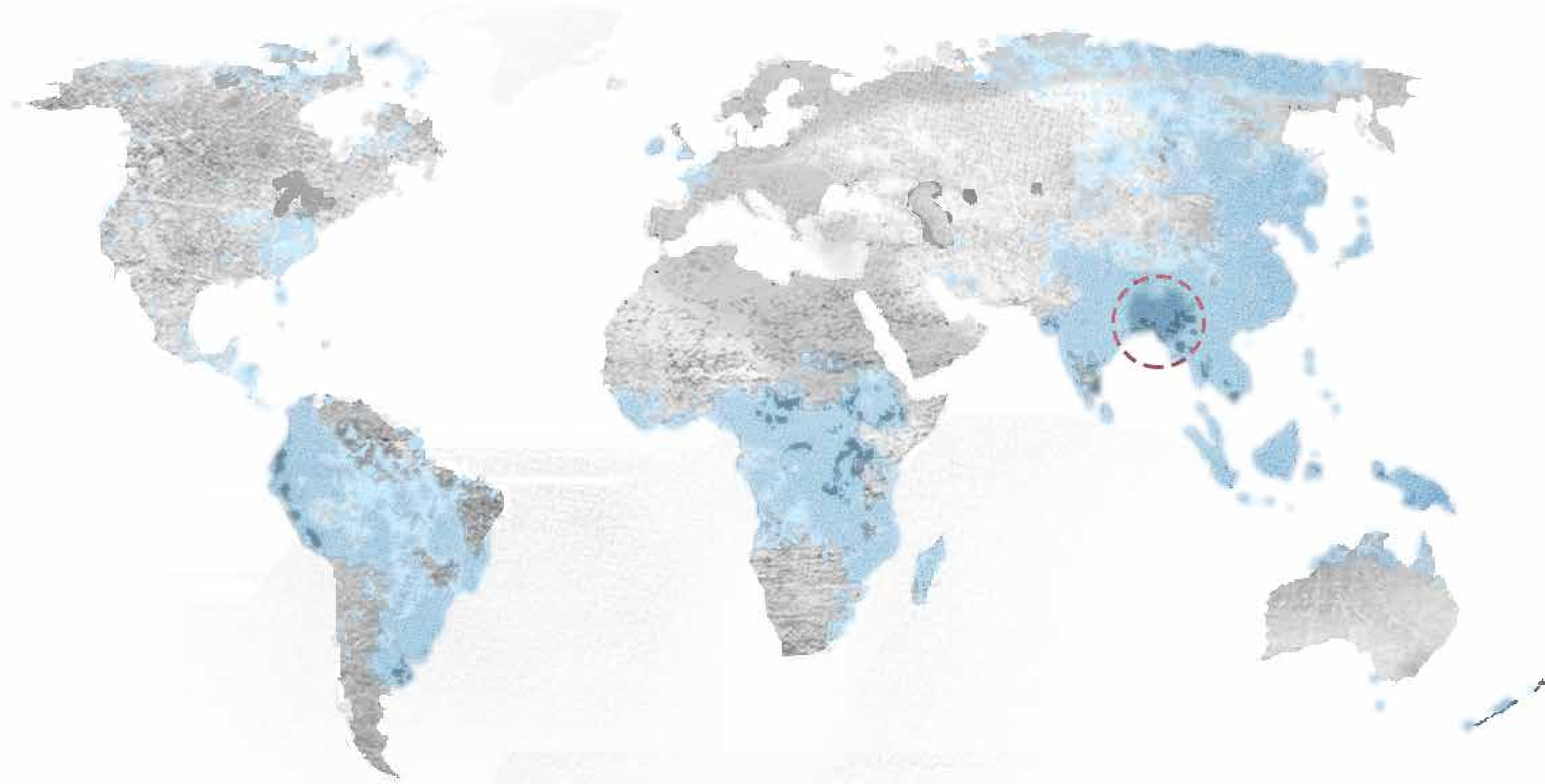

INTRODUCTION

Problem statement

LACK OF MEANS

to move or create preventive measures



LACK OF SANITATION

is the cause of polluted floodwater, which creates health risks

INTRODUCTION

Problem statement

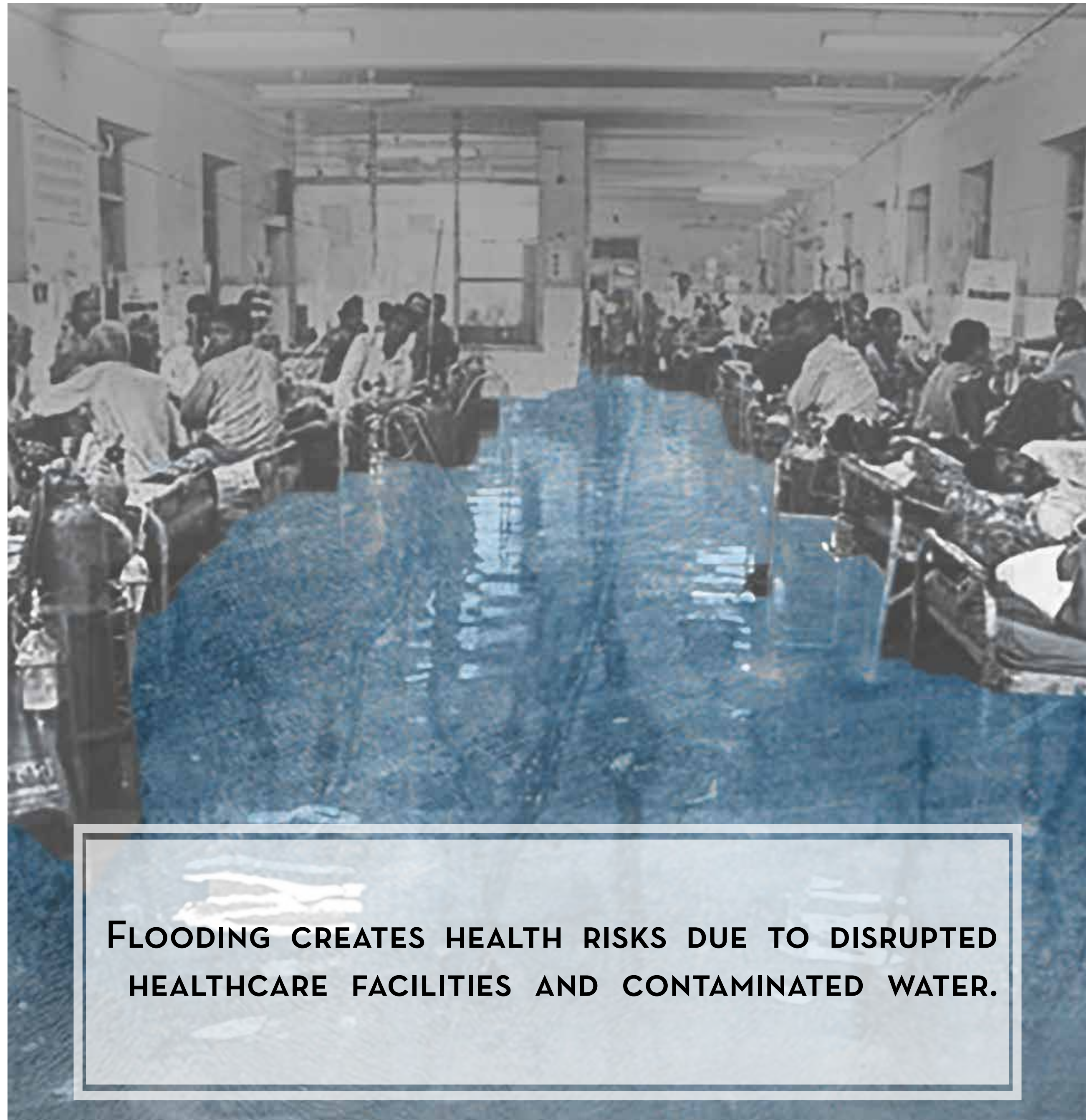

INTRODUCTION

Problem Statement

68%

of India's population lives in rural areas.

30%

of India's healthcare facilities are in a rural environment.

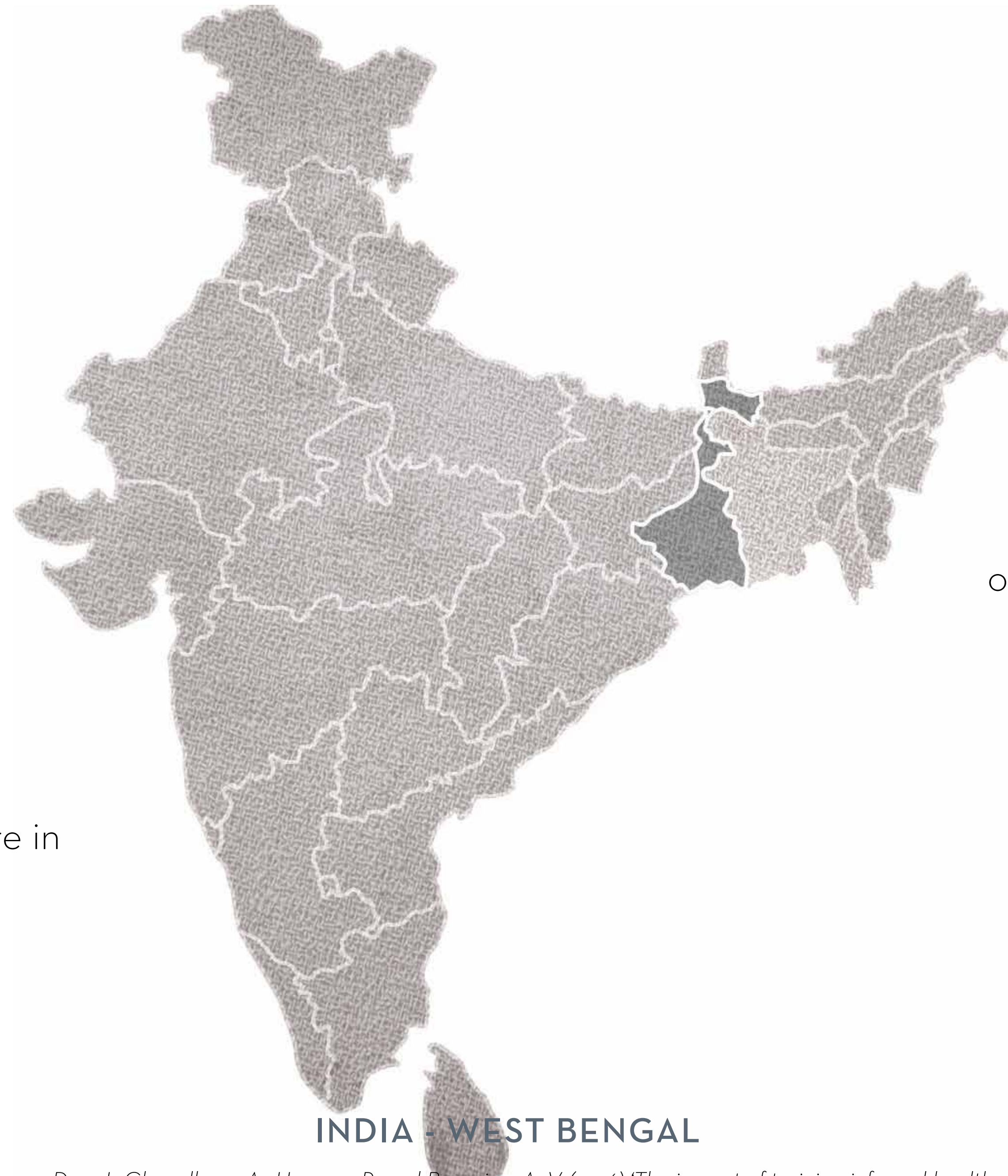

INDIA - WEST BENGAL

>70%

of patients in rural India are treated by informal practitioners: "Quacks" whom had no medical training.

Source: Das, J., Chowdhury, A., Hussam, R. and Banerjee, A. V. (2016) 'The impact of training informal health care providers in India: A randomized controlled trial', Science, 354(6308).

INTRODUCTION

Problem Statement

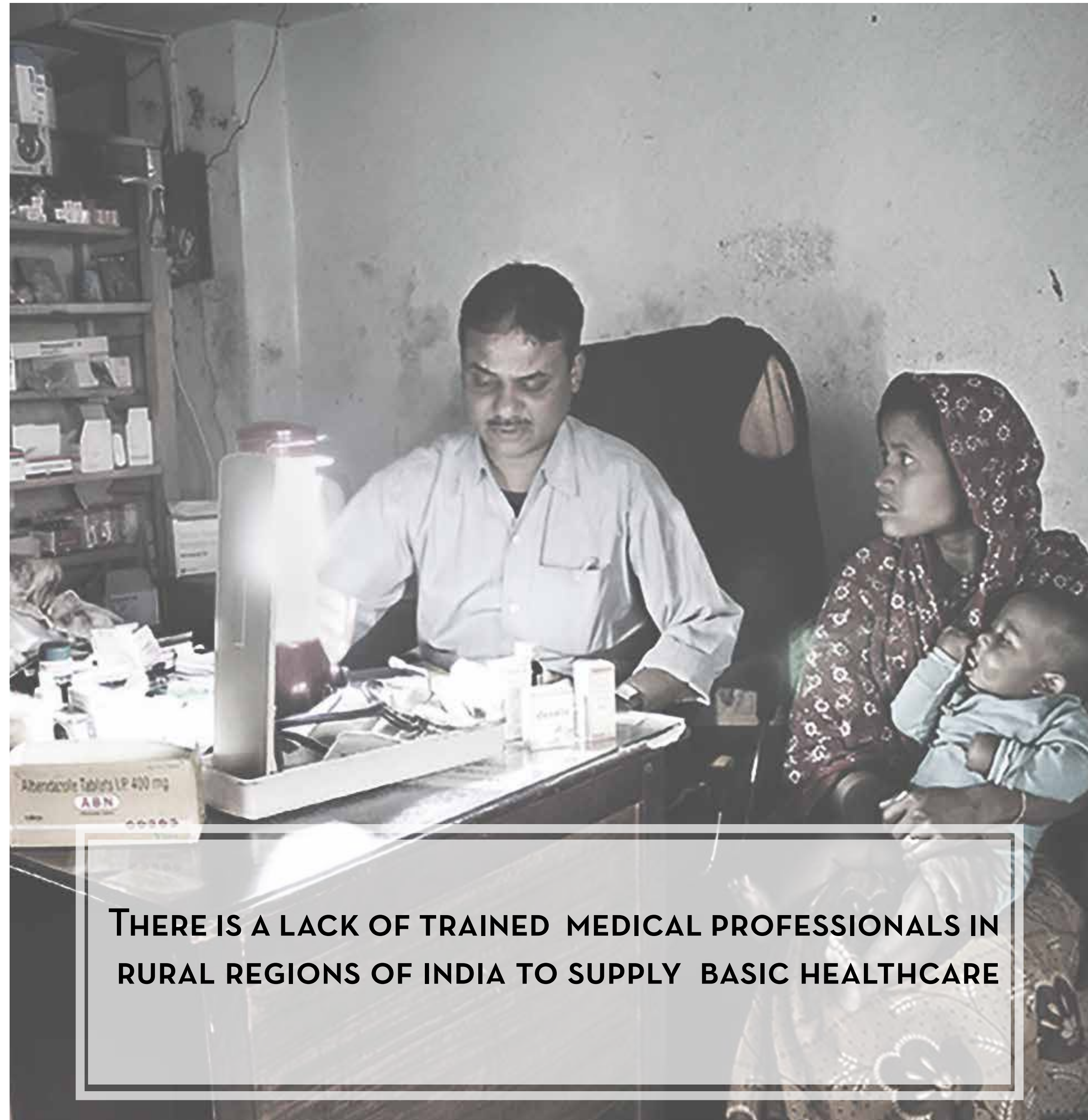

THERE IS A LACK OF TRAINED MEDICAL PROFESSIONALS IN RURAL REGIONS OF INDIA TO SUPPLY BASIC HEALTHCARE

INTRODUCTION

Problem Statements

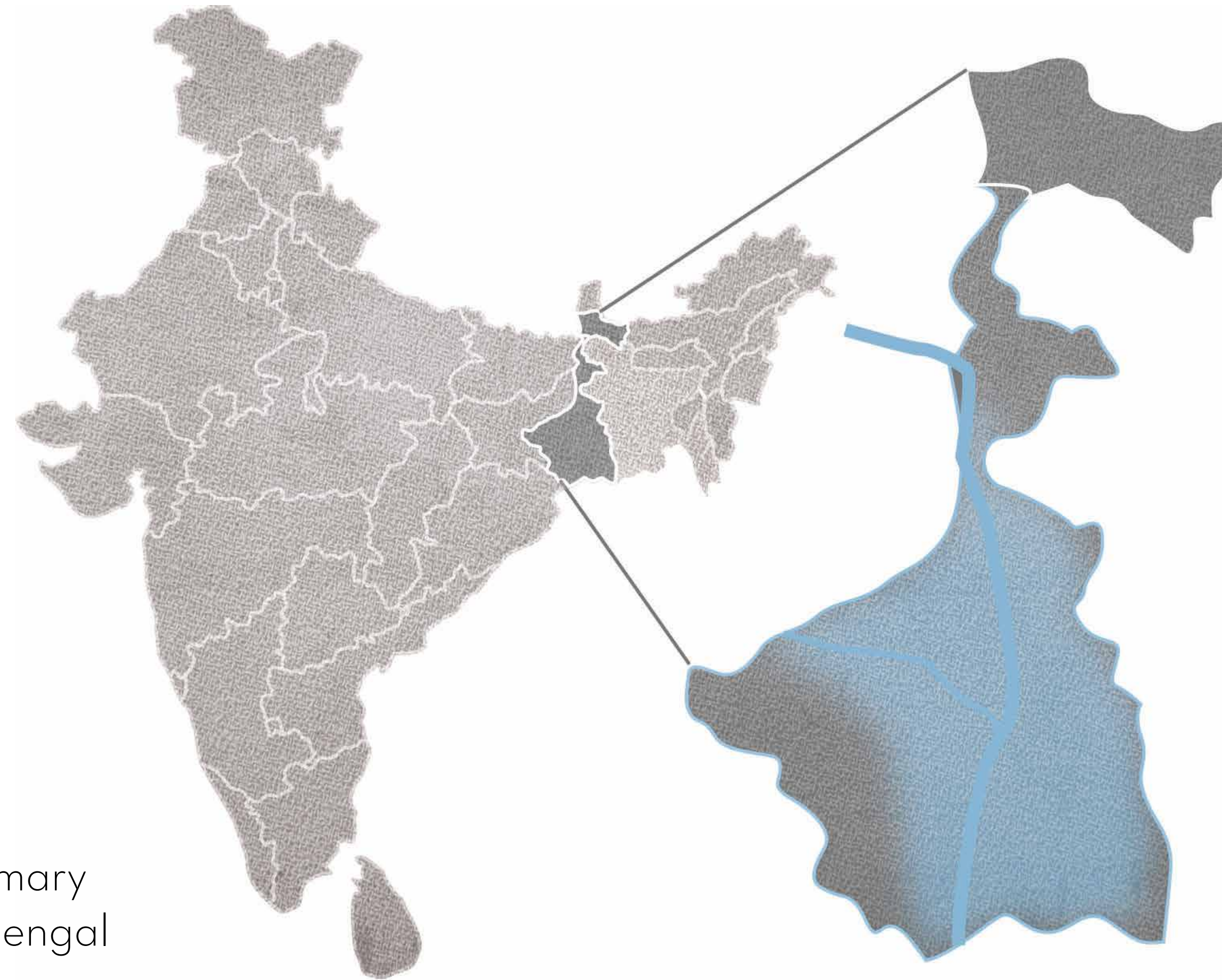

36%

Available of the needed primary
healthcare centres in West-Bengal

909 / 2500

(Indian norm for a population of 90 million)

FLOOD PRONE AREA OF WEST-BENGAL

INTRODUCTION

Problem Statements



HEAVY MONSOON FLOODS

3 - 5 months in a year the West-Bengal is plagued by heavy floods..



LACK OF FACILITIES

A rural region with little funds available to create preventive solutions and with a lack of facilities



LACK OF KNOWLEDGE

trained medical personnel moves out of the rural region to higher salaries in cities

INTRODUCTION

Objective

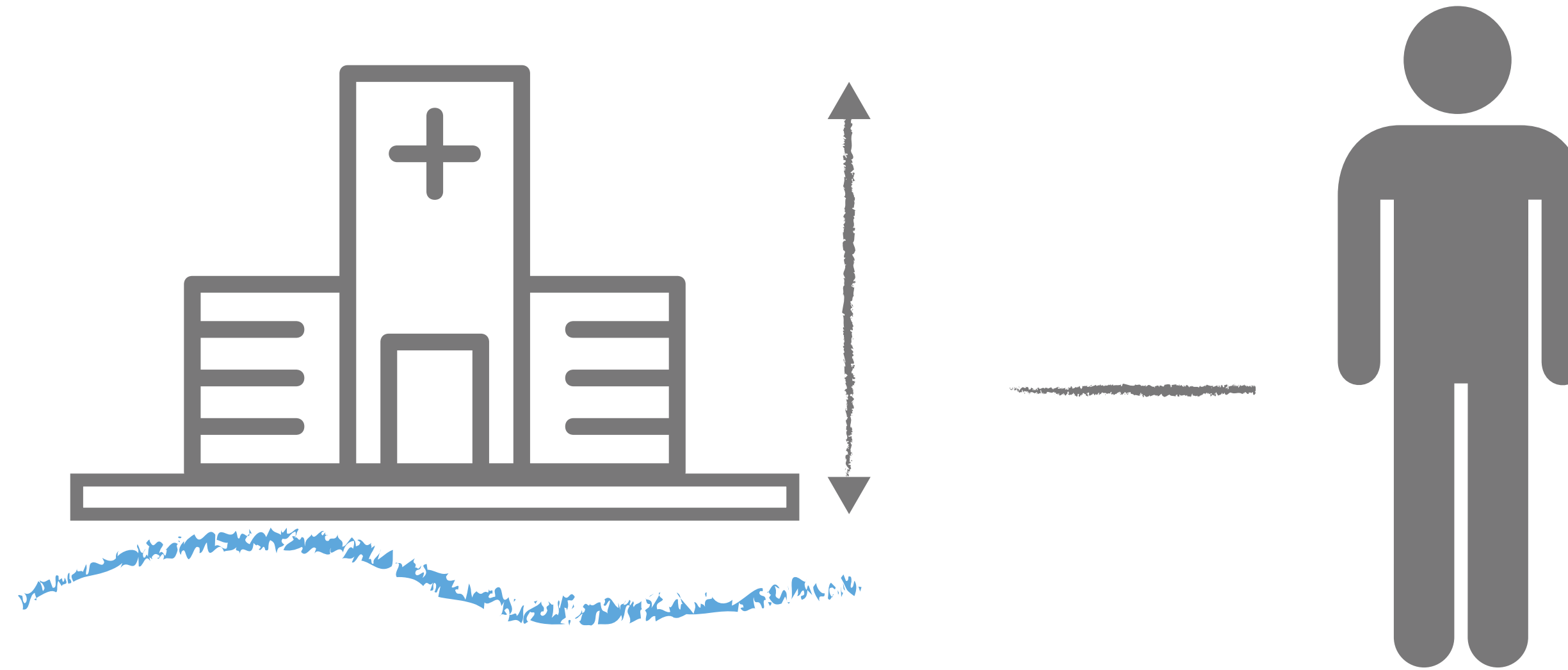

DEVELOP A *PERMANENT* SOLUTION FOR LOW INCOME, FLOOD PRONE AREAS BY OFFERING *FLOATING* HEALTHCARE AND MEDICAL TRAINING FACILITIES.

TO CREATE REAL SELF-RESILLIENCE, THE STRUCTURE SHOULD BE *BUILD* AND *OWNED* *LOCALLY*.

INTRODUCTION

Needs

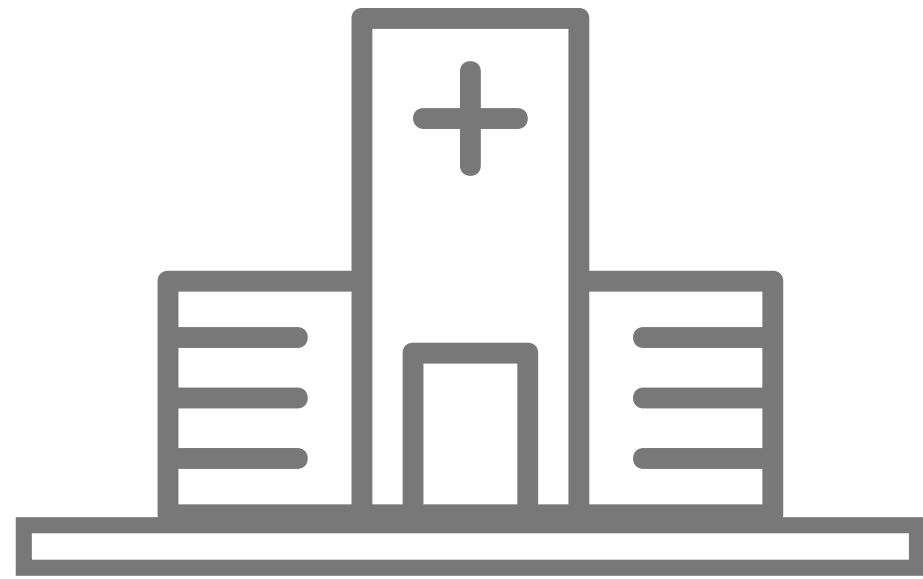

MEDICAL CLINIC

INTRODUCTION

Needs

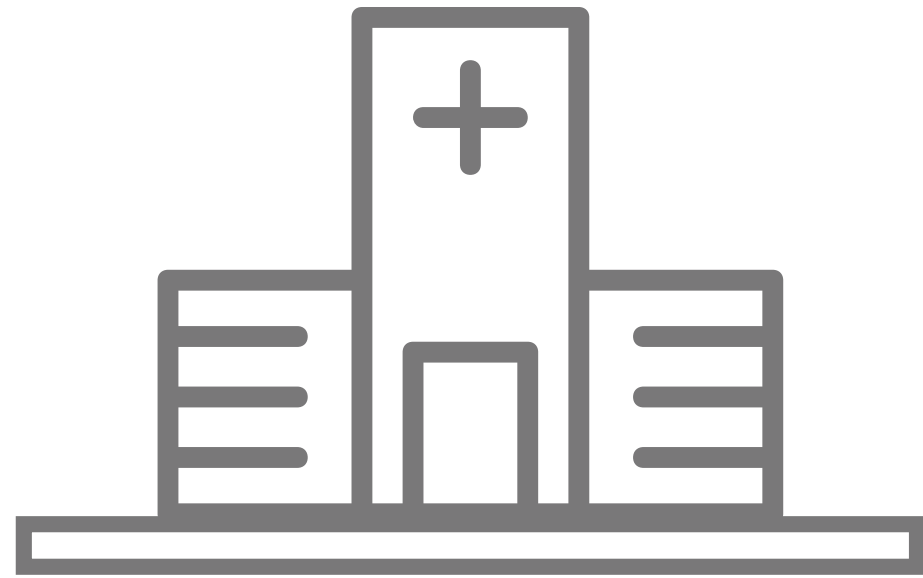

MEDICAL CLINIC



TRAINING CENTER

INTRODUCTION

Needs

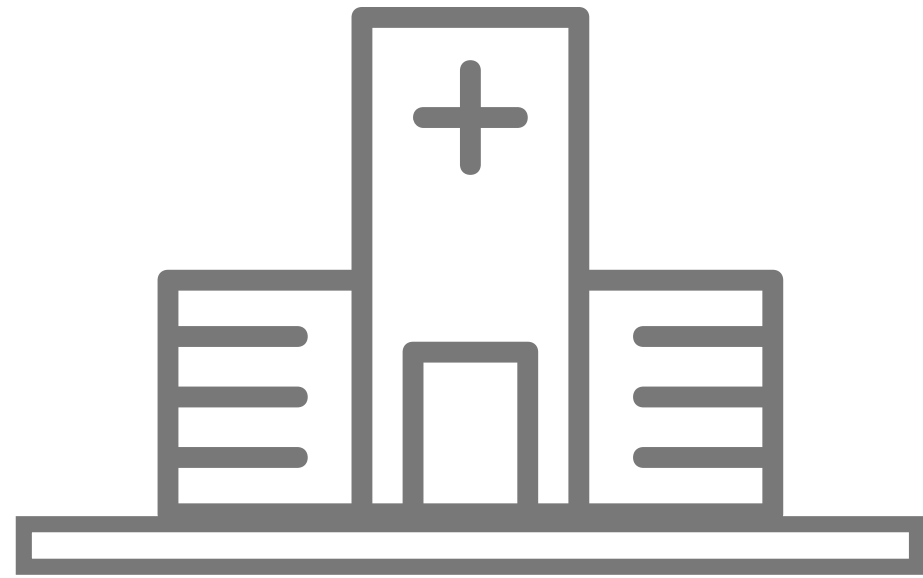

MEDICAL CLINIC

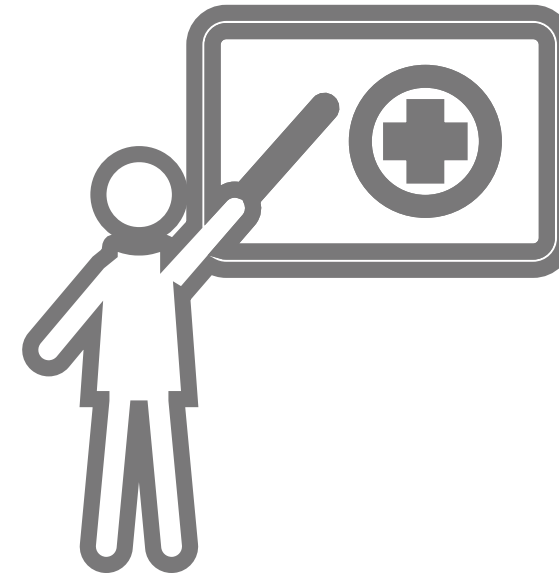

TRAINING CENTER



COMMUNITY /
EMERGENCY

BUILDING SYSTEM

BUILDING SYSTEM

Requirements

FLOOD RESISTANT

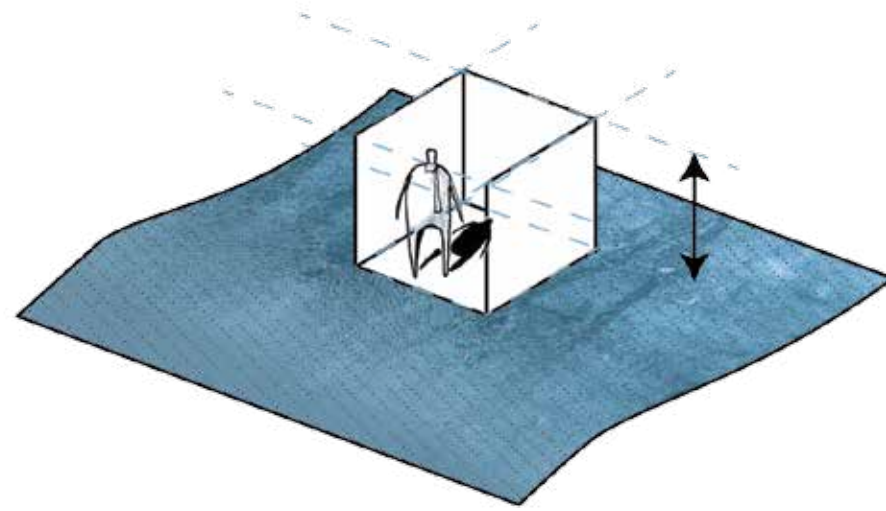

REPRODUCIBLE

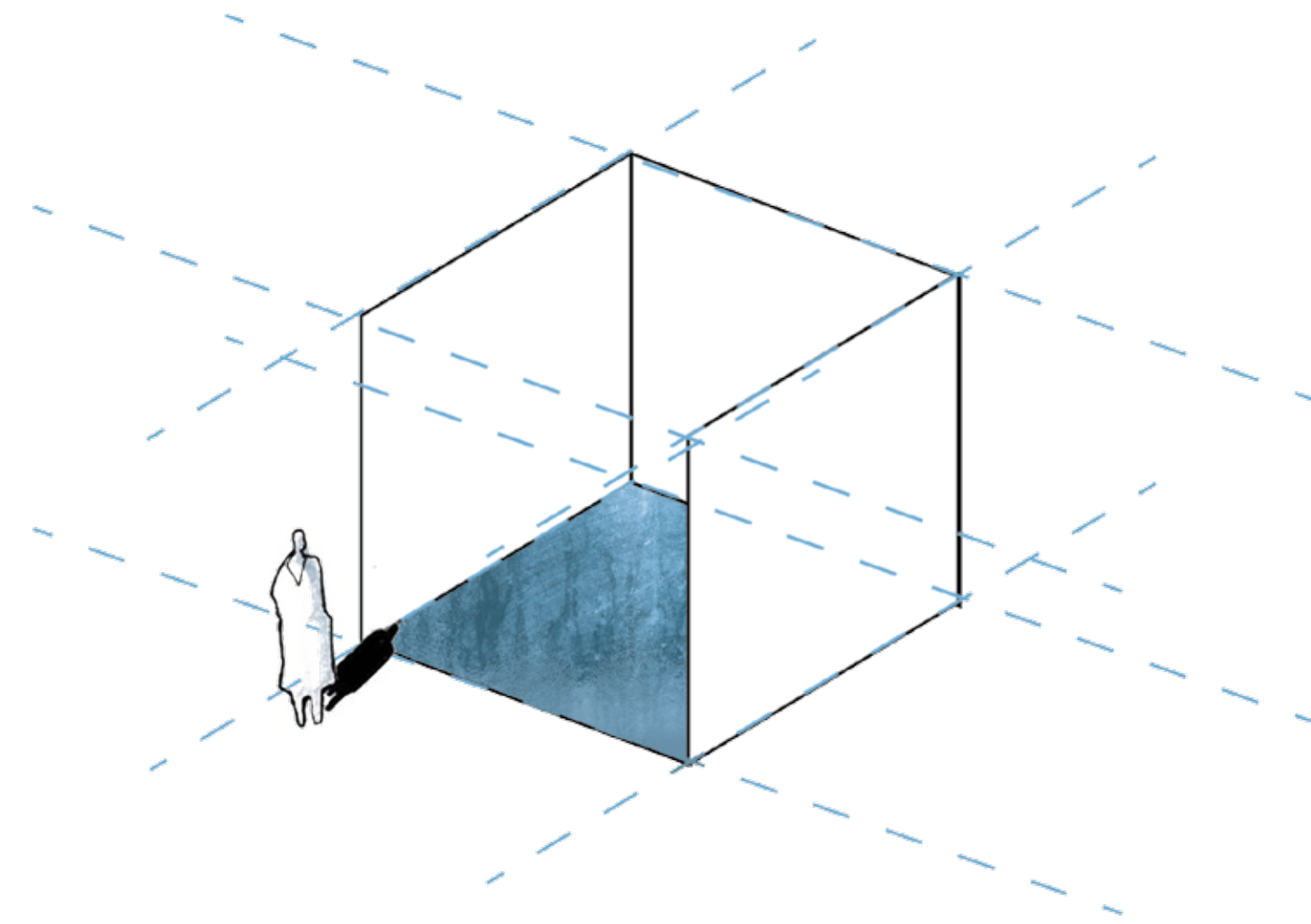
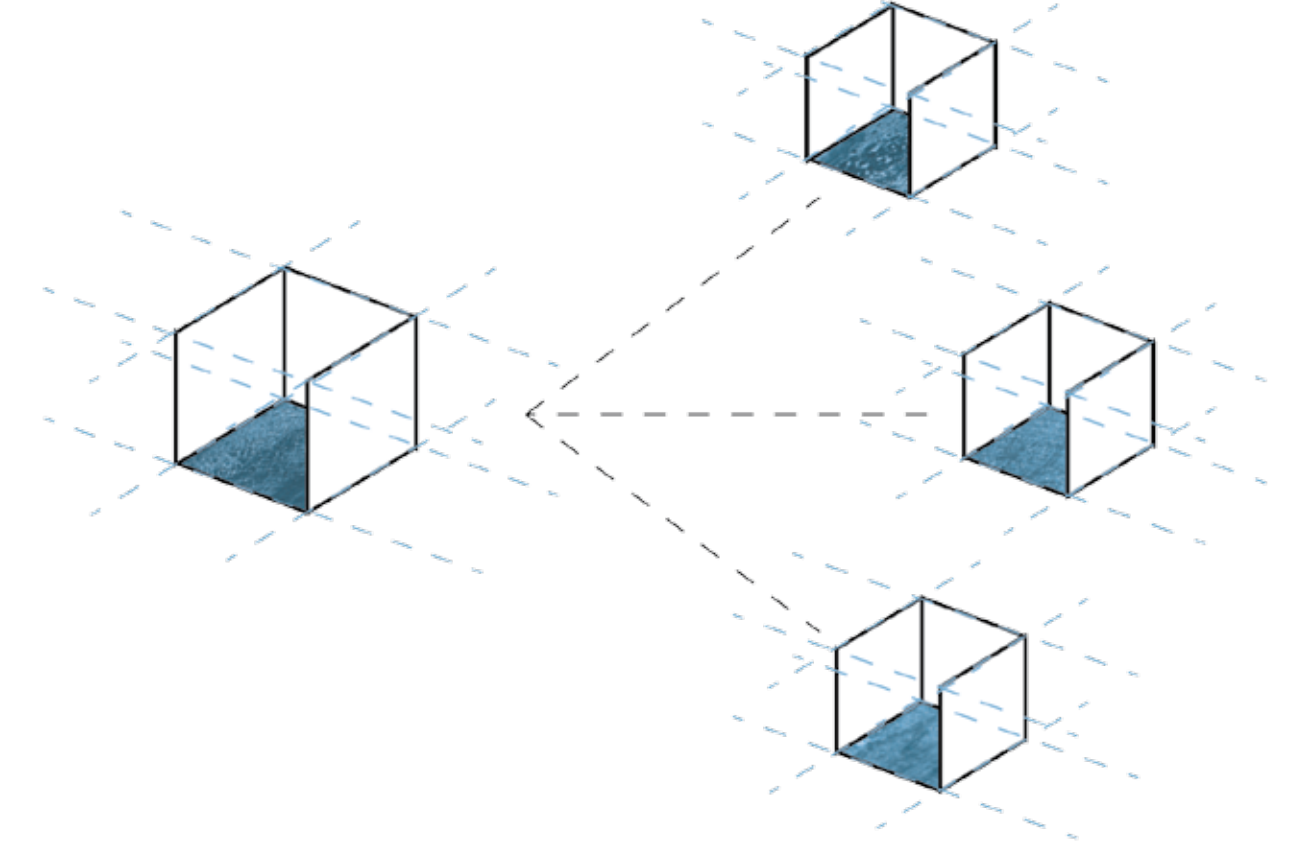

EASY CONSTRUCTION

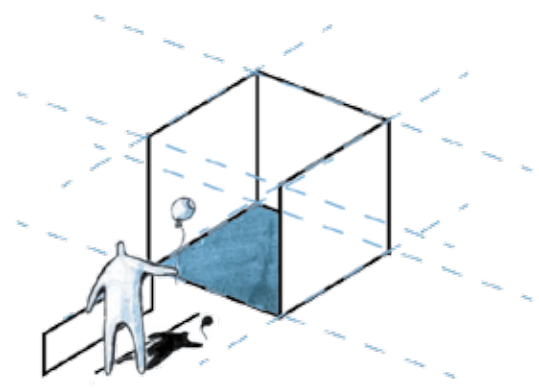

MODULAR SETUP

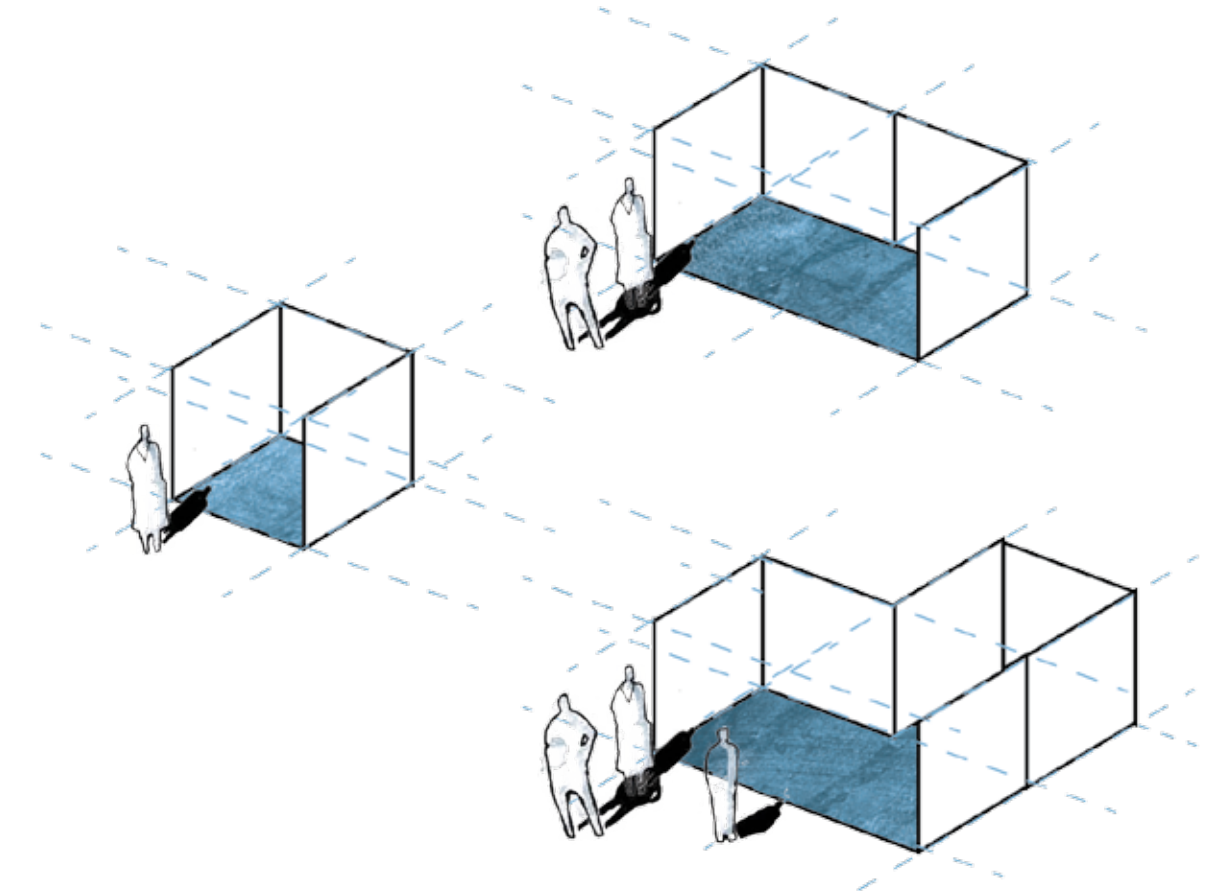

REQUIREMENTS

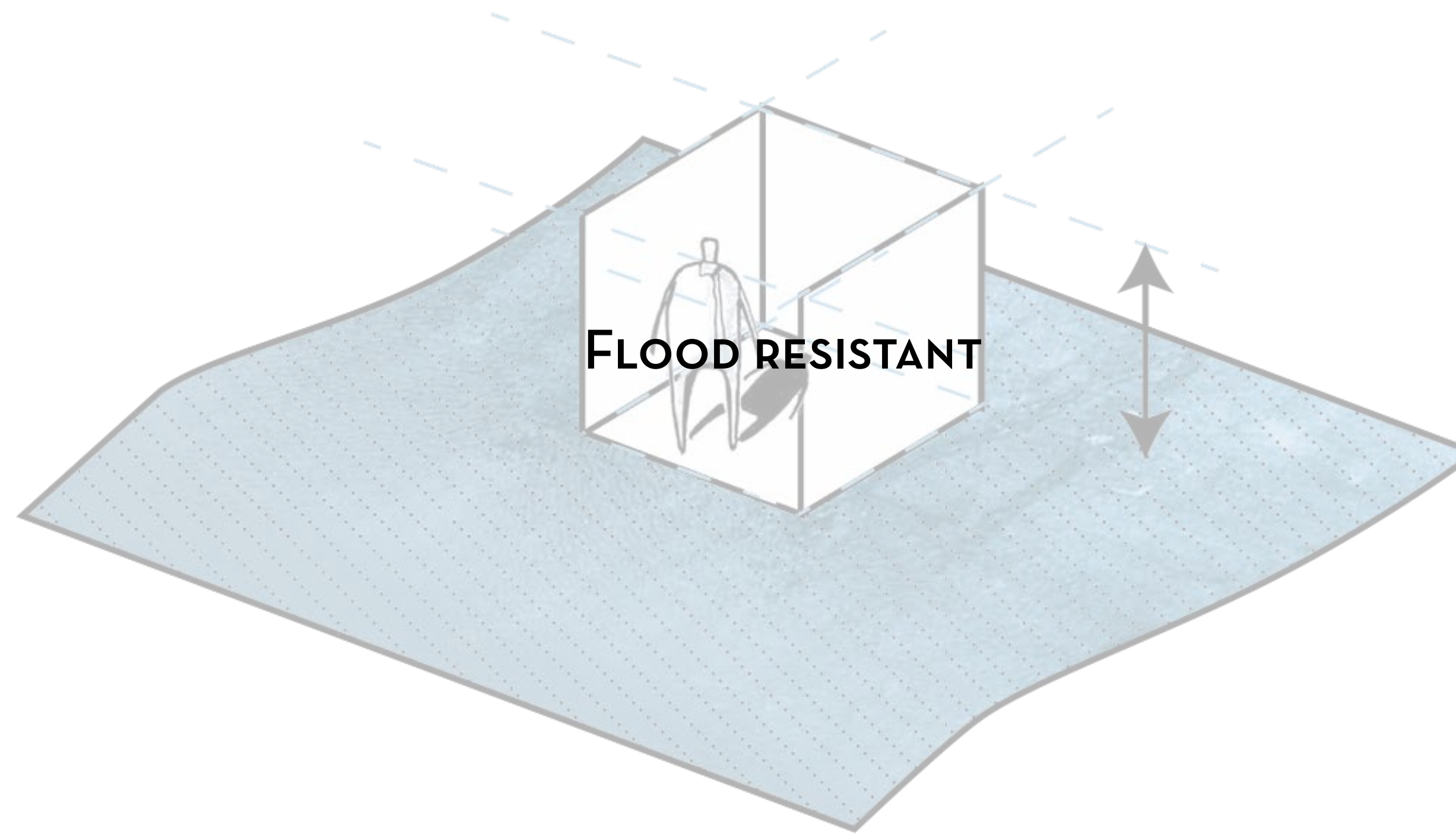

BUILDING SYSTEM

Floating

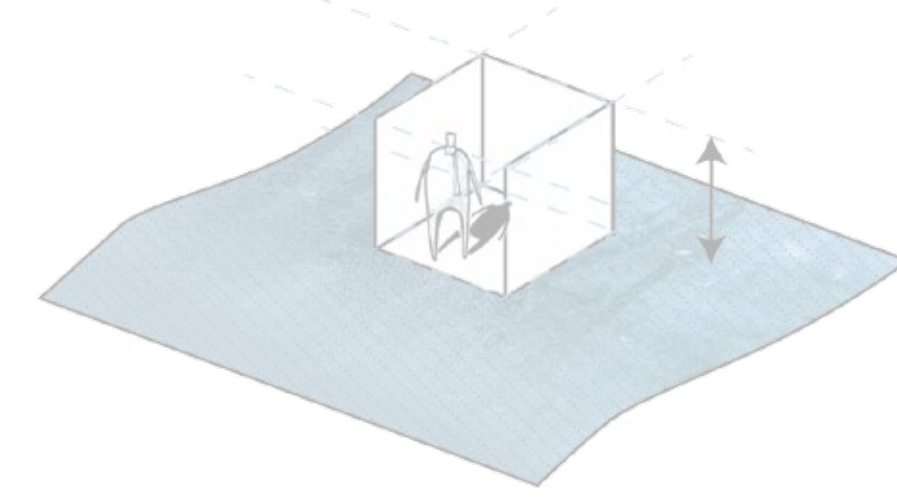

BUILDING SYSTEM

Grid

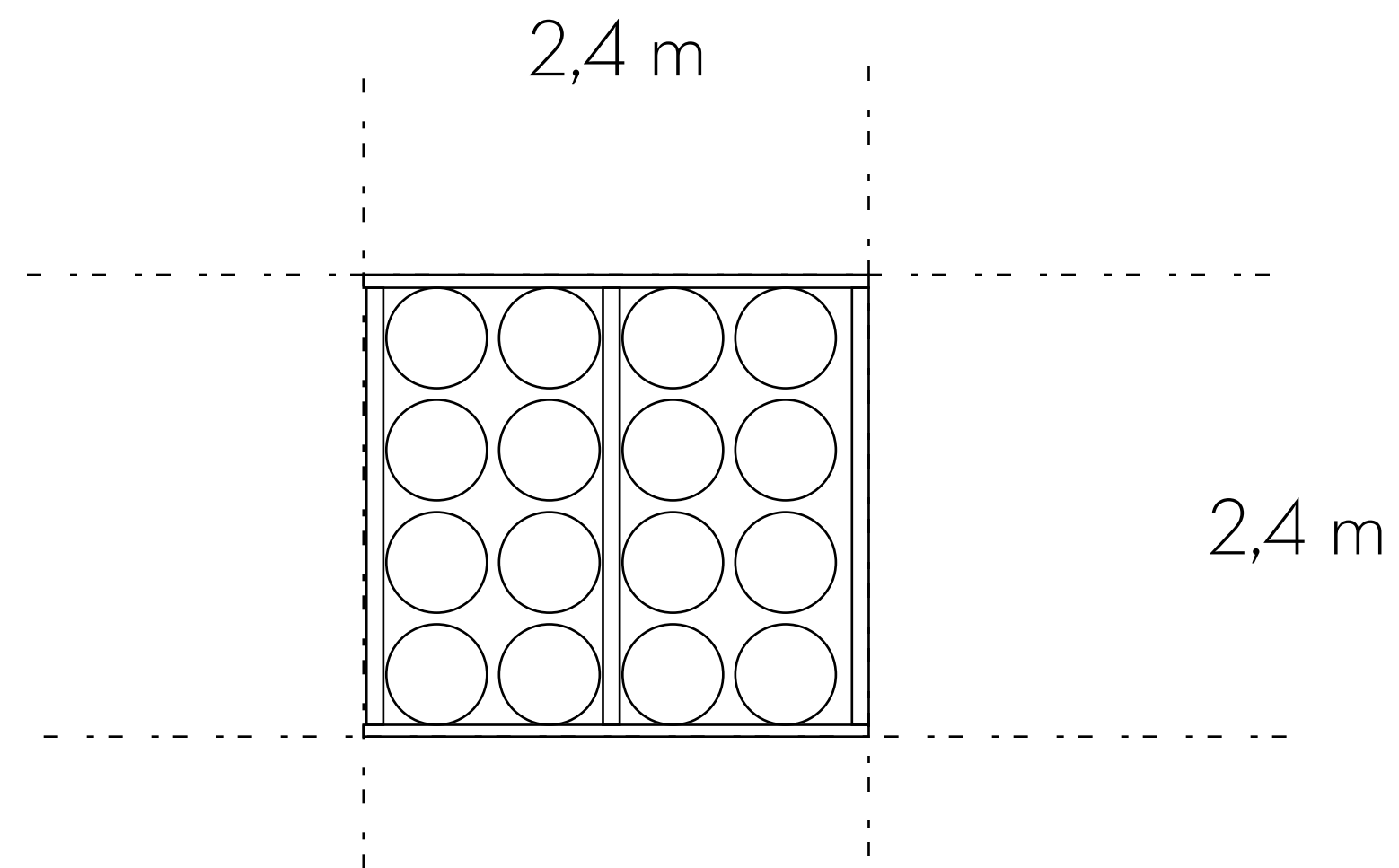
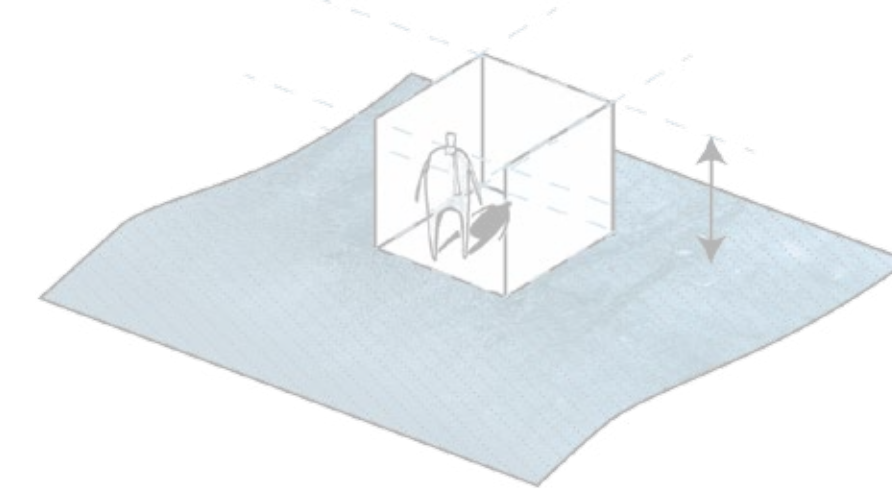

FLOATING STRUCTURE

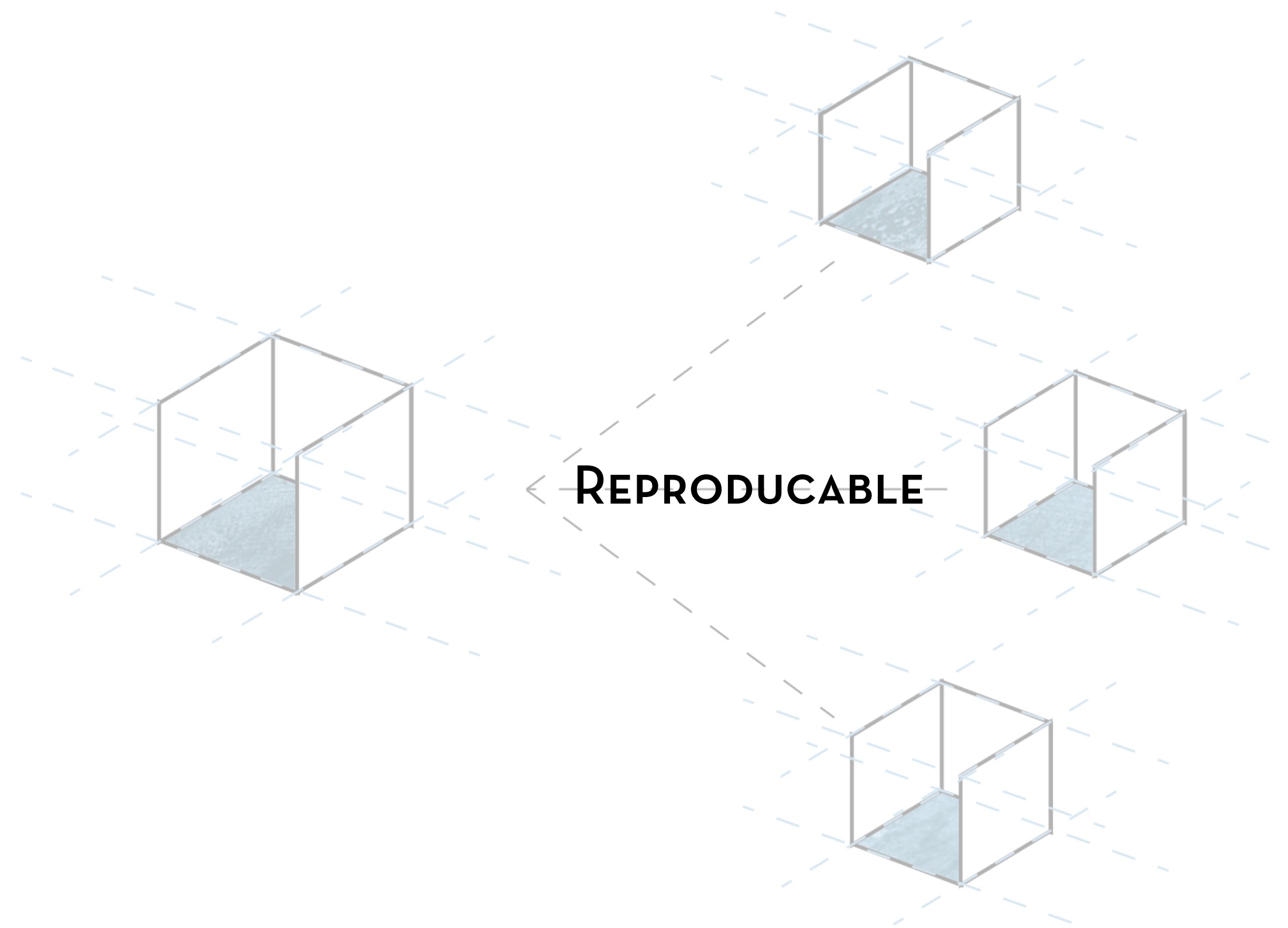

BUILDING SYSTEM

Material

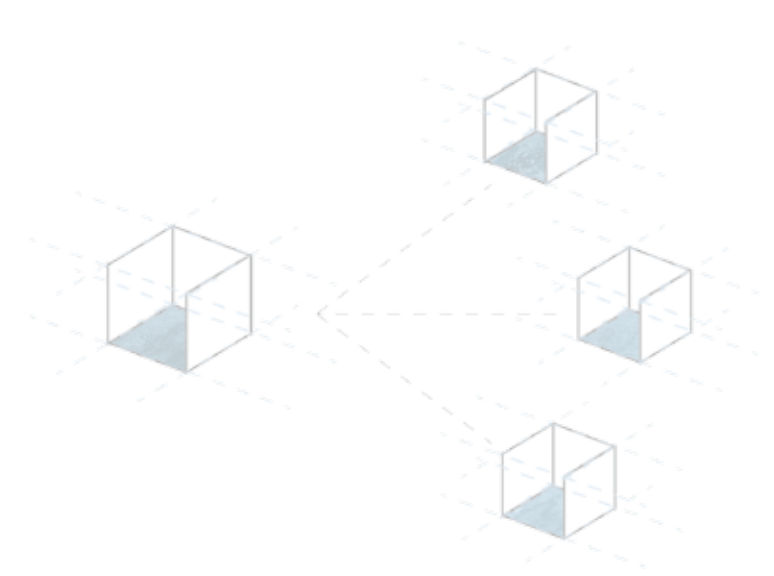

*Globally available/
relatively cheap/
easy to process/
standardized dimensions*

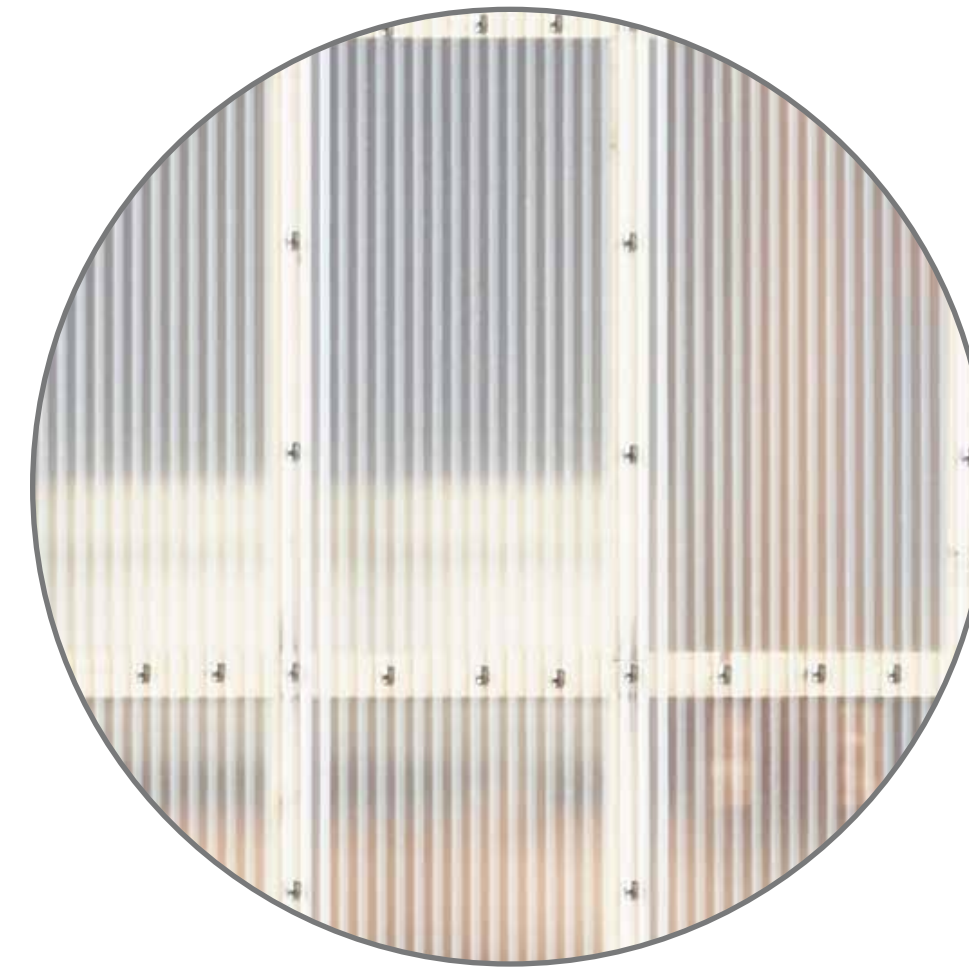

*Durable /
Standardized dimensions/
Simple connections*

MATERIALS

PROGRAM

Layout

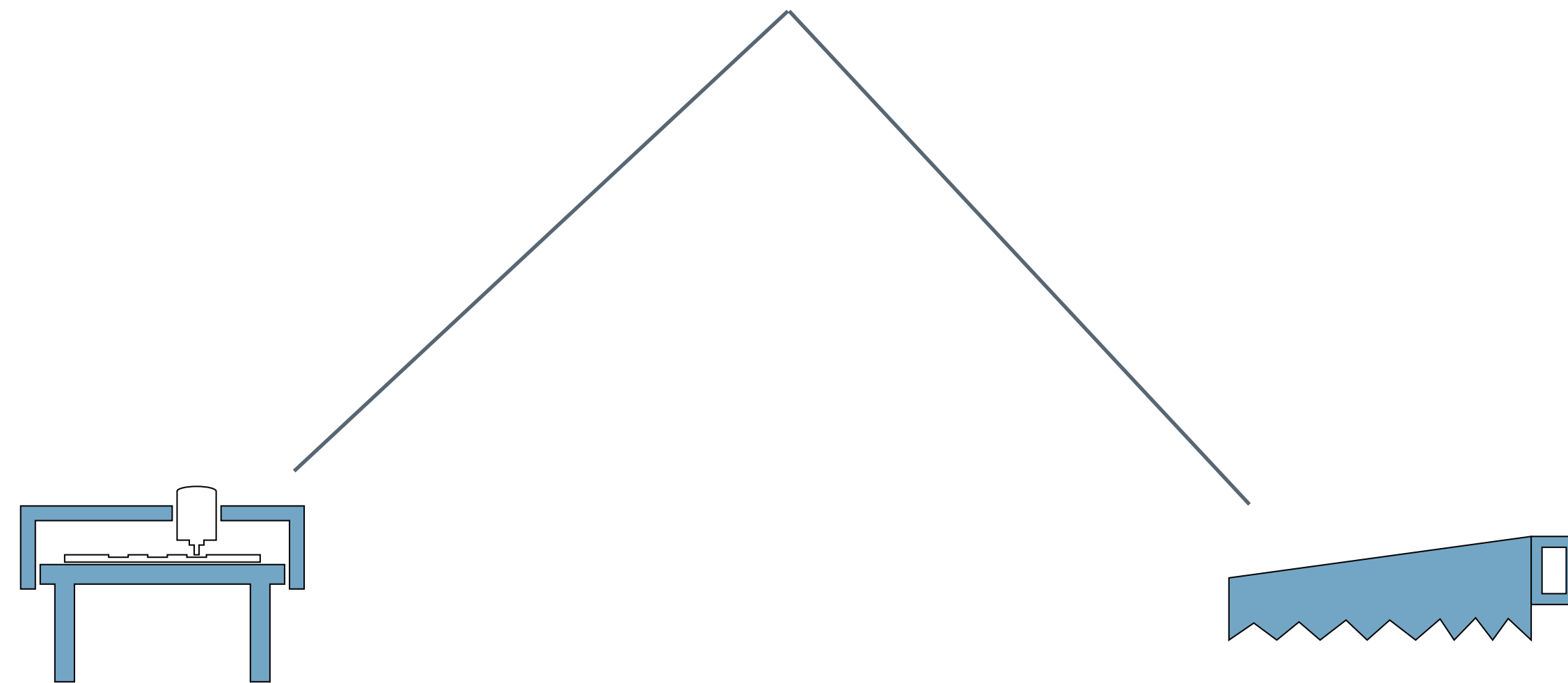
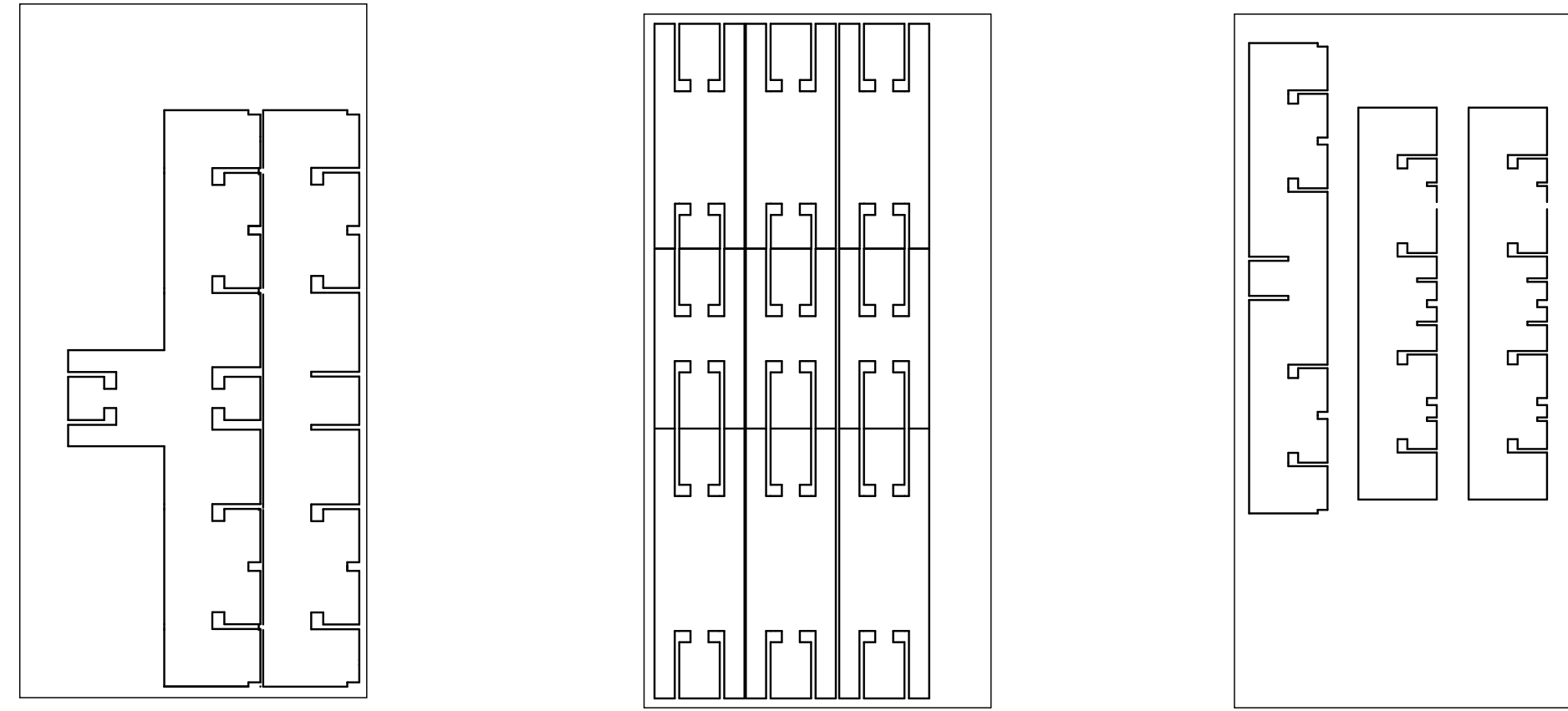
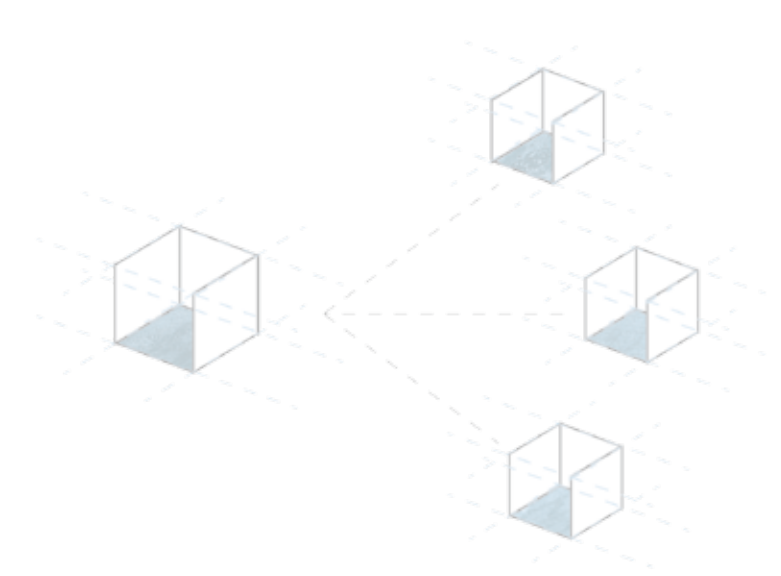

TECHNIQUE

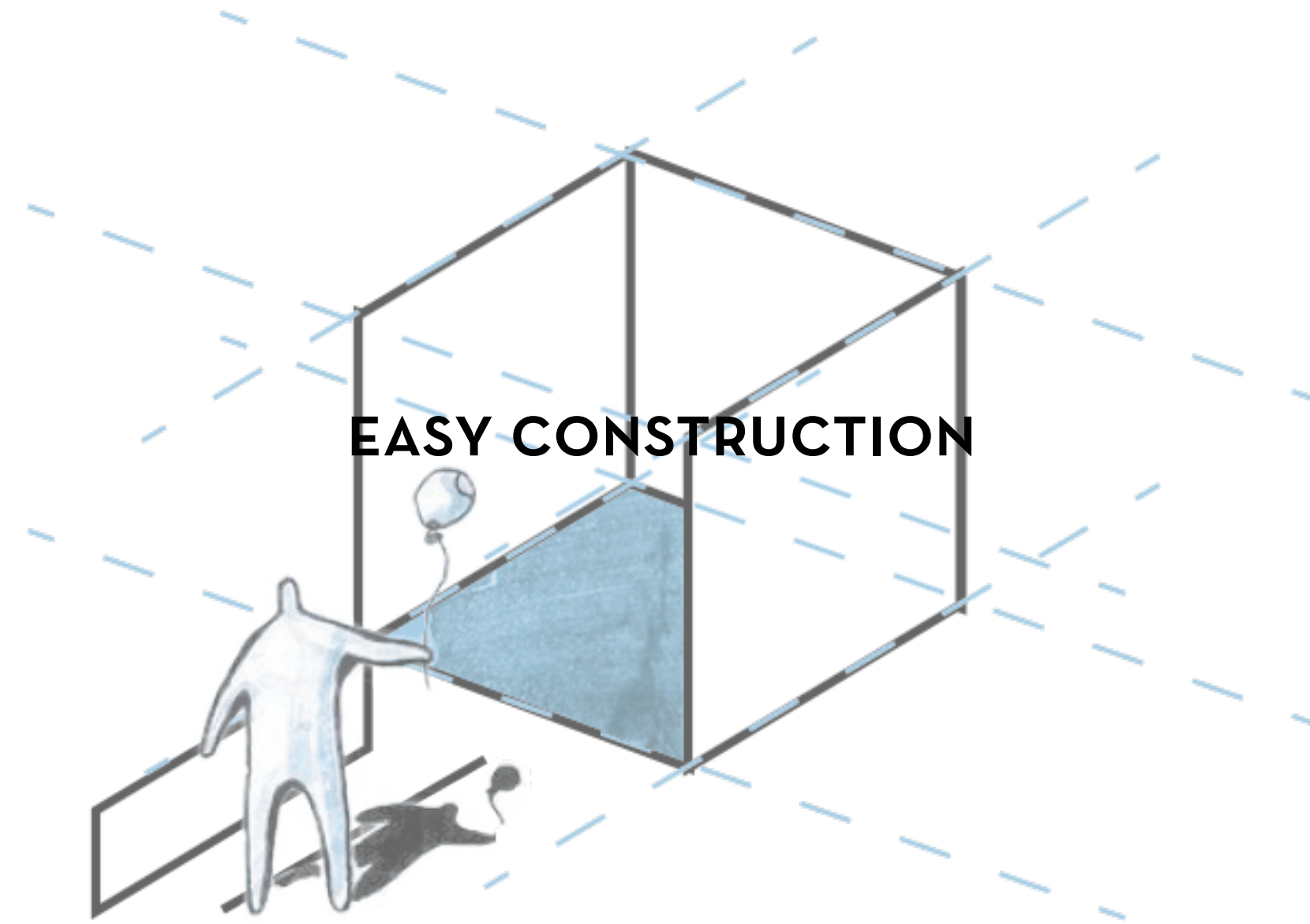

BUILDING SYSTEM

System

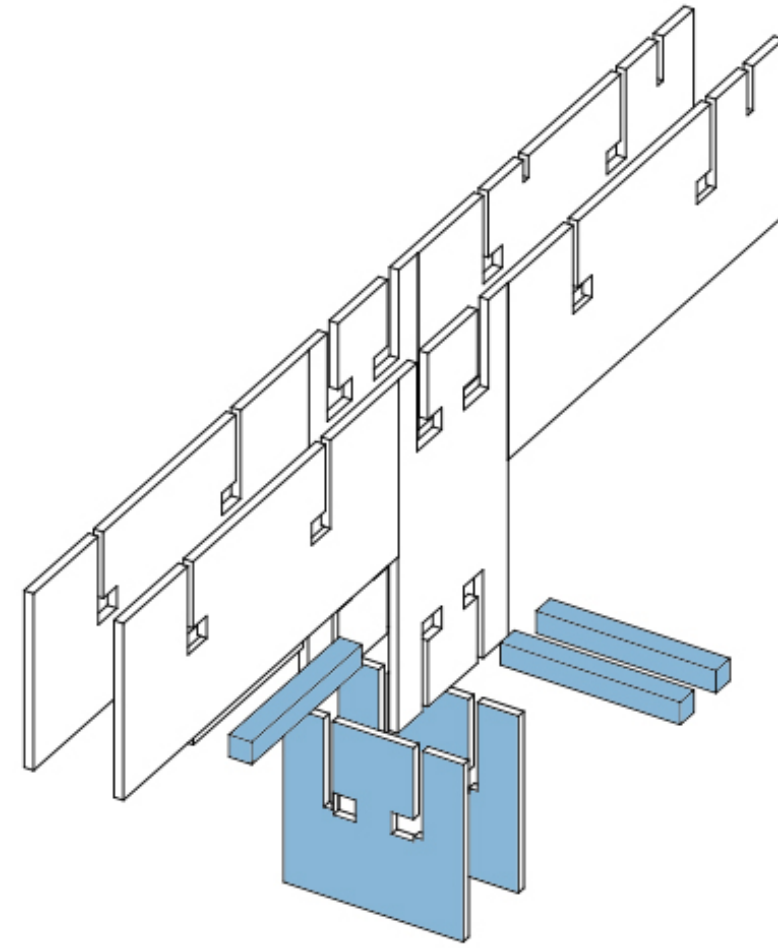
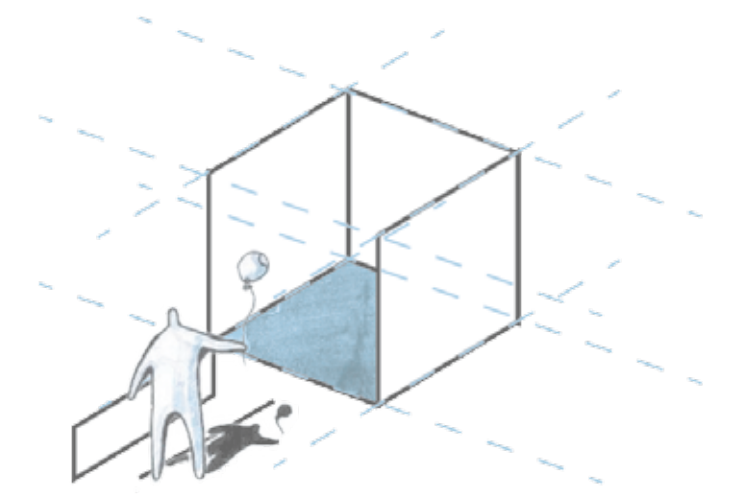

BUILDING SYSTEM

Building sequence

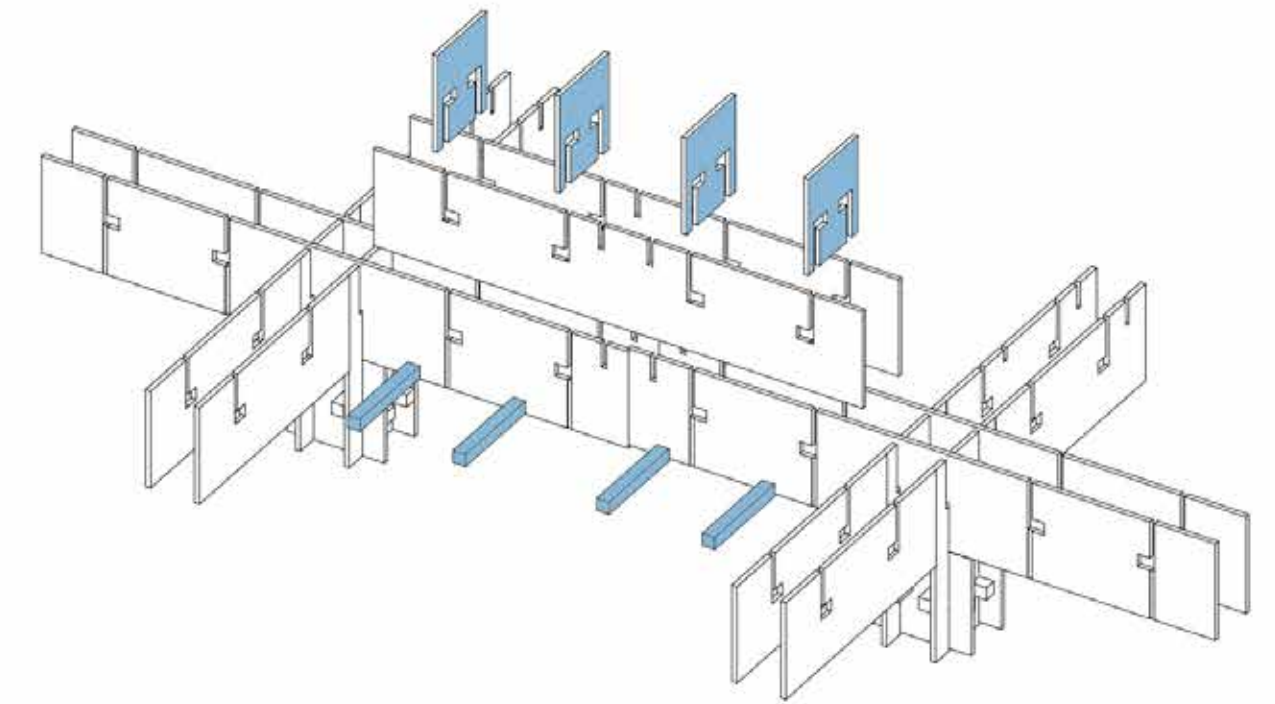
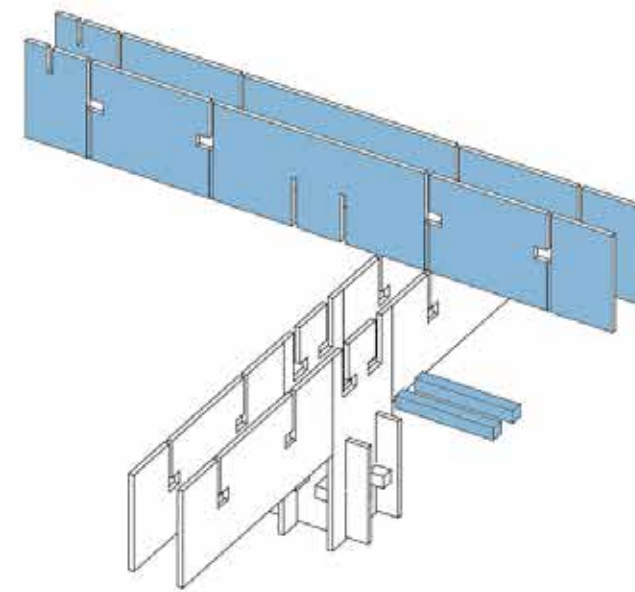
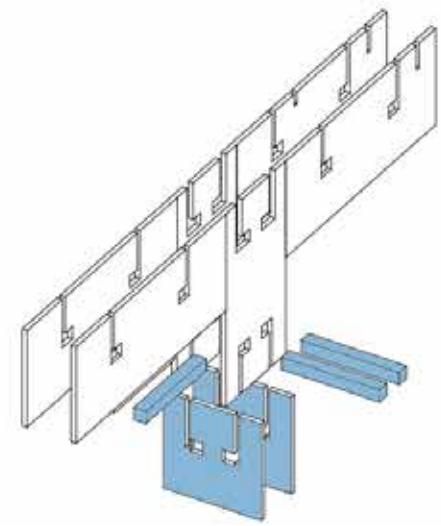
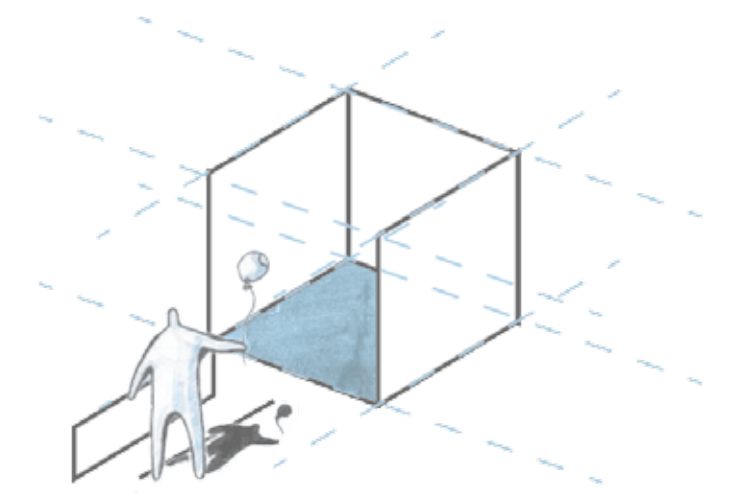

TECHNIQUE

BUILDING SYSTEM

Building sequence

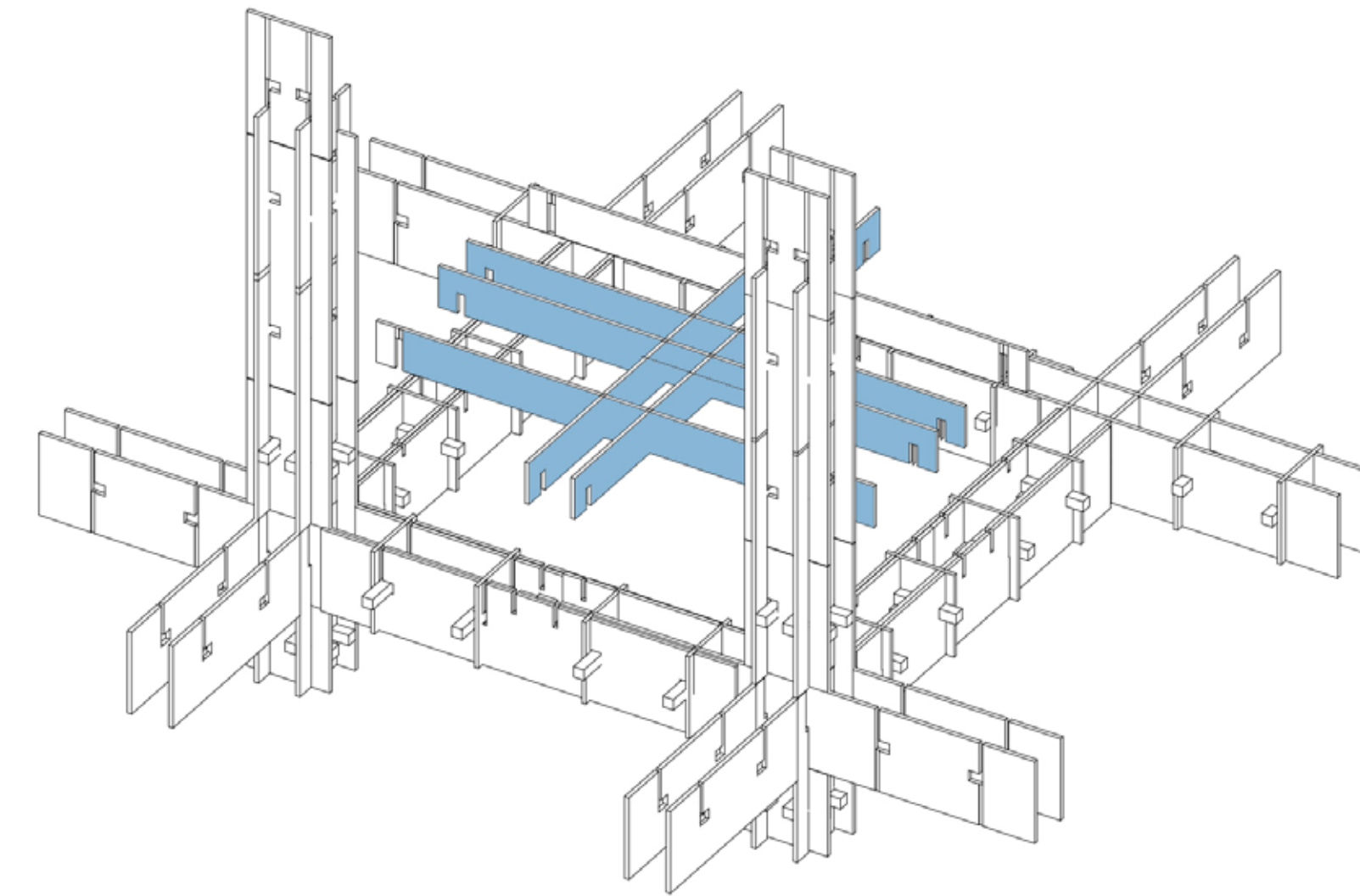
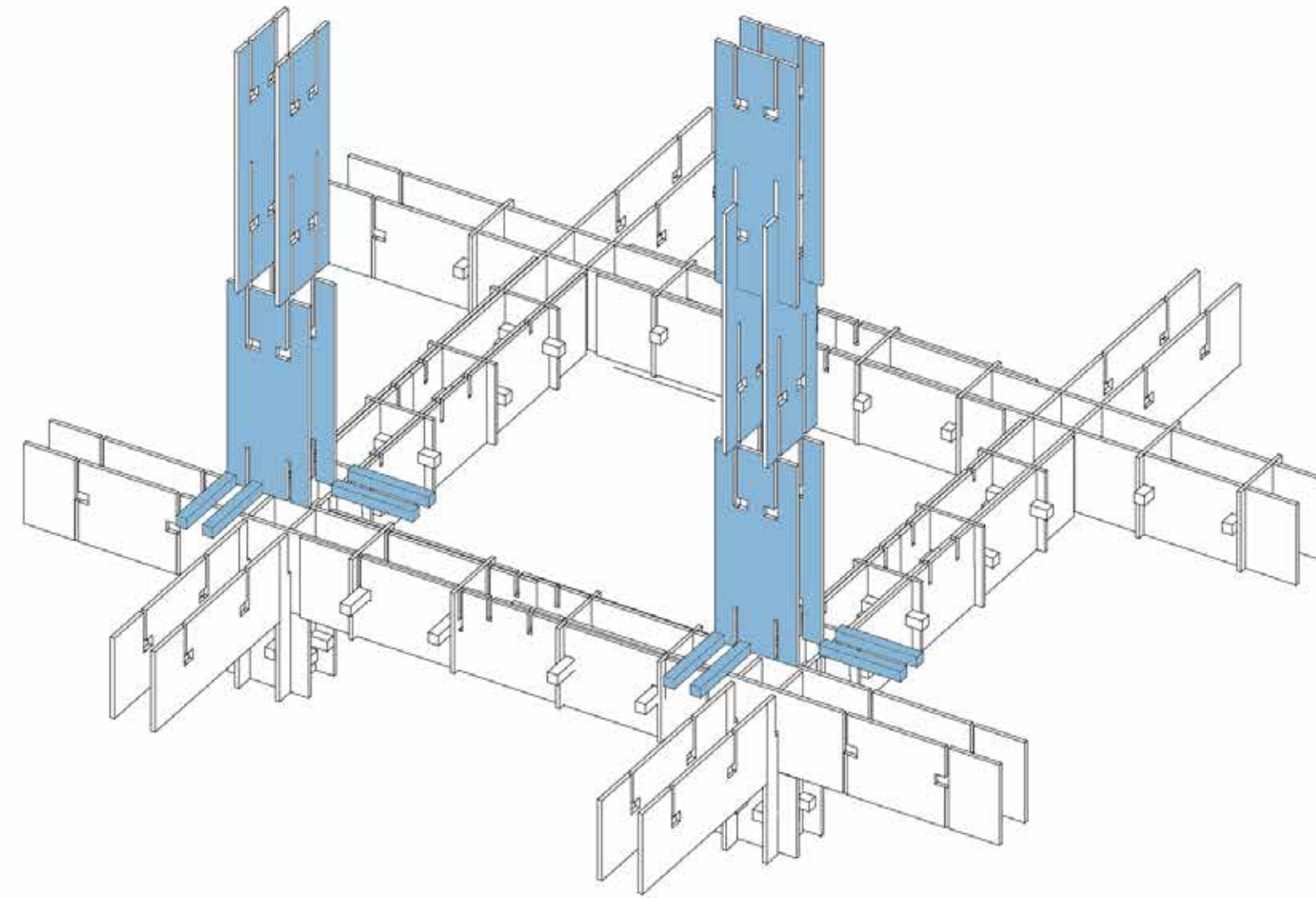
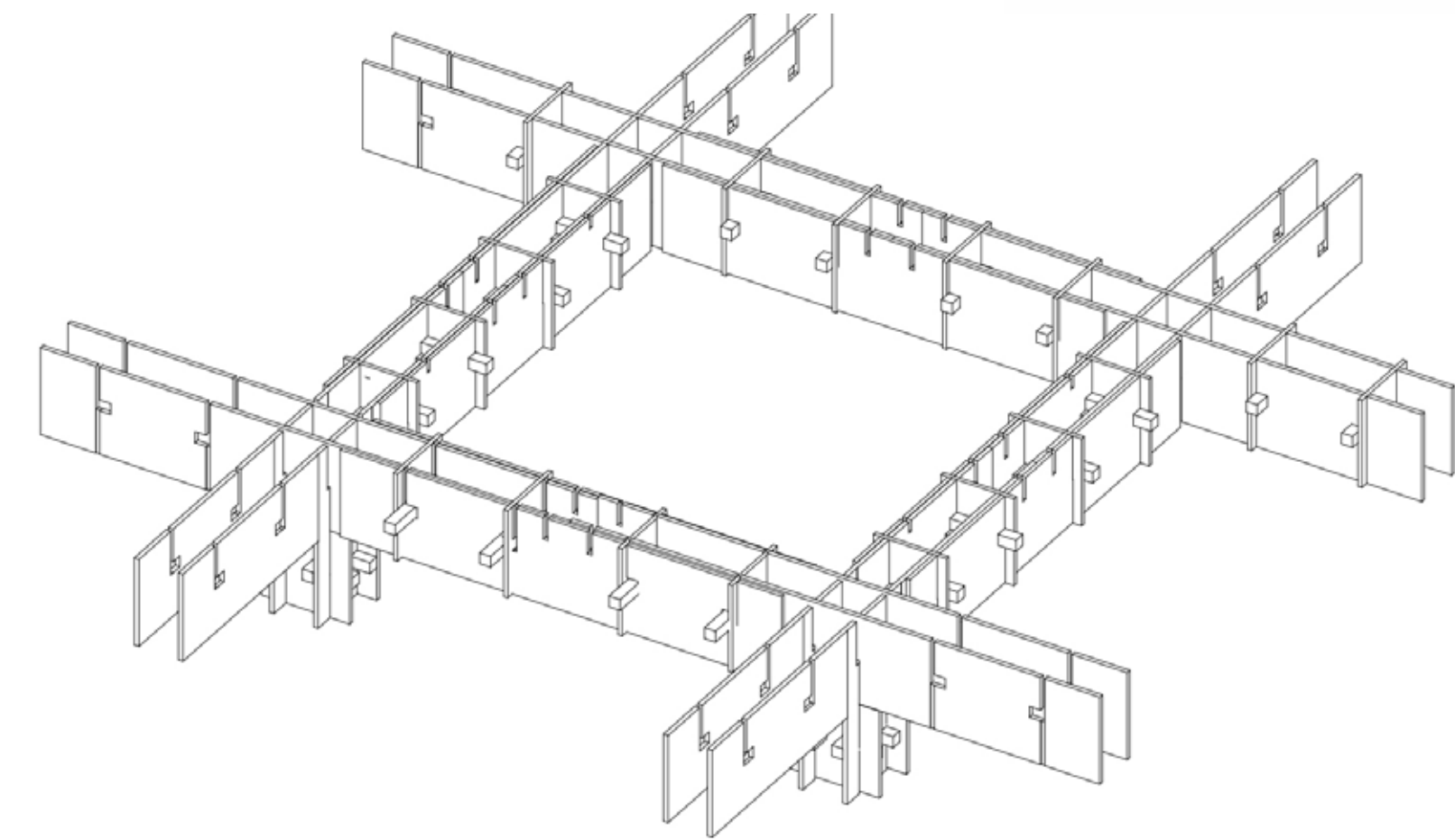
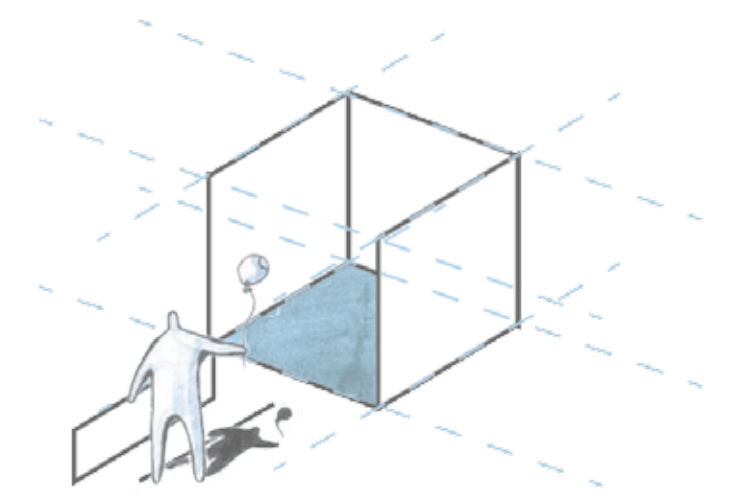

TECHNIQUE

BUILDING SYSTEM

Building sequence

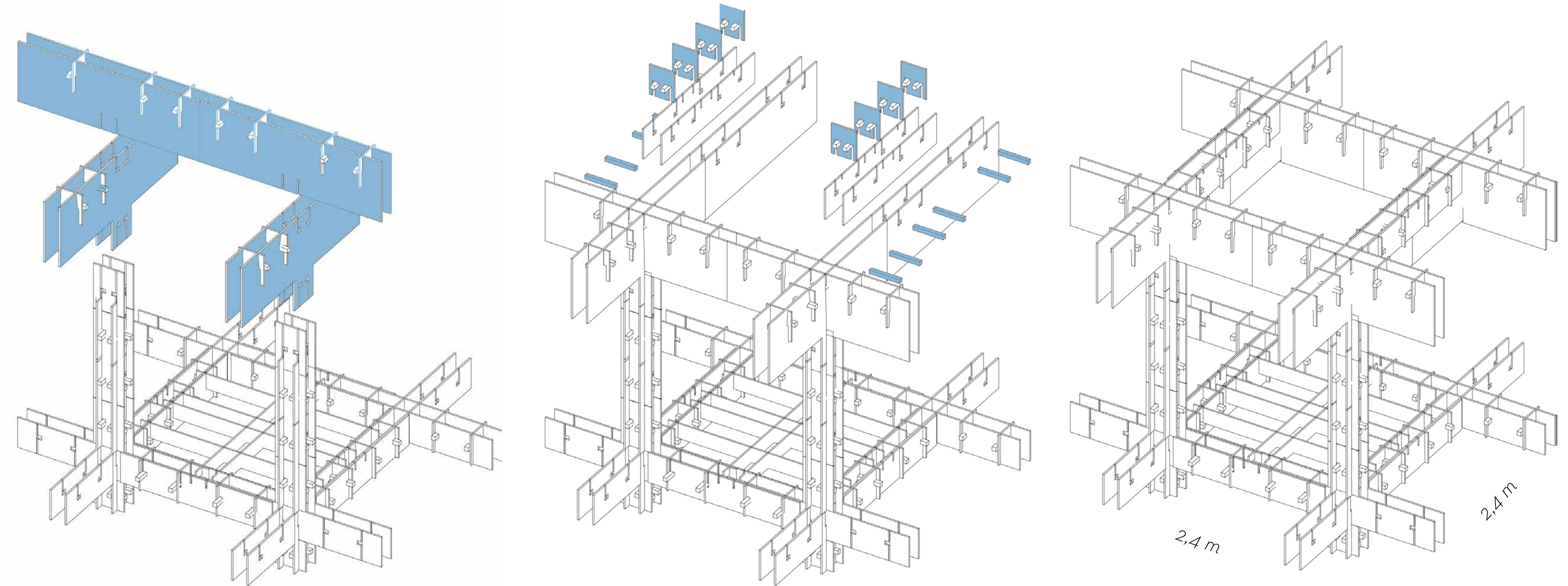
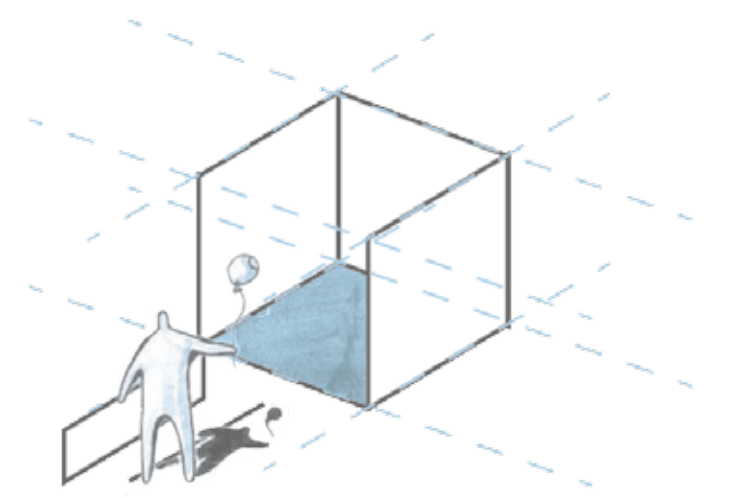

TECHNIQUE

BUILDING SYSTEM

Building sequence

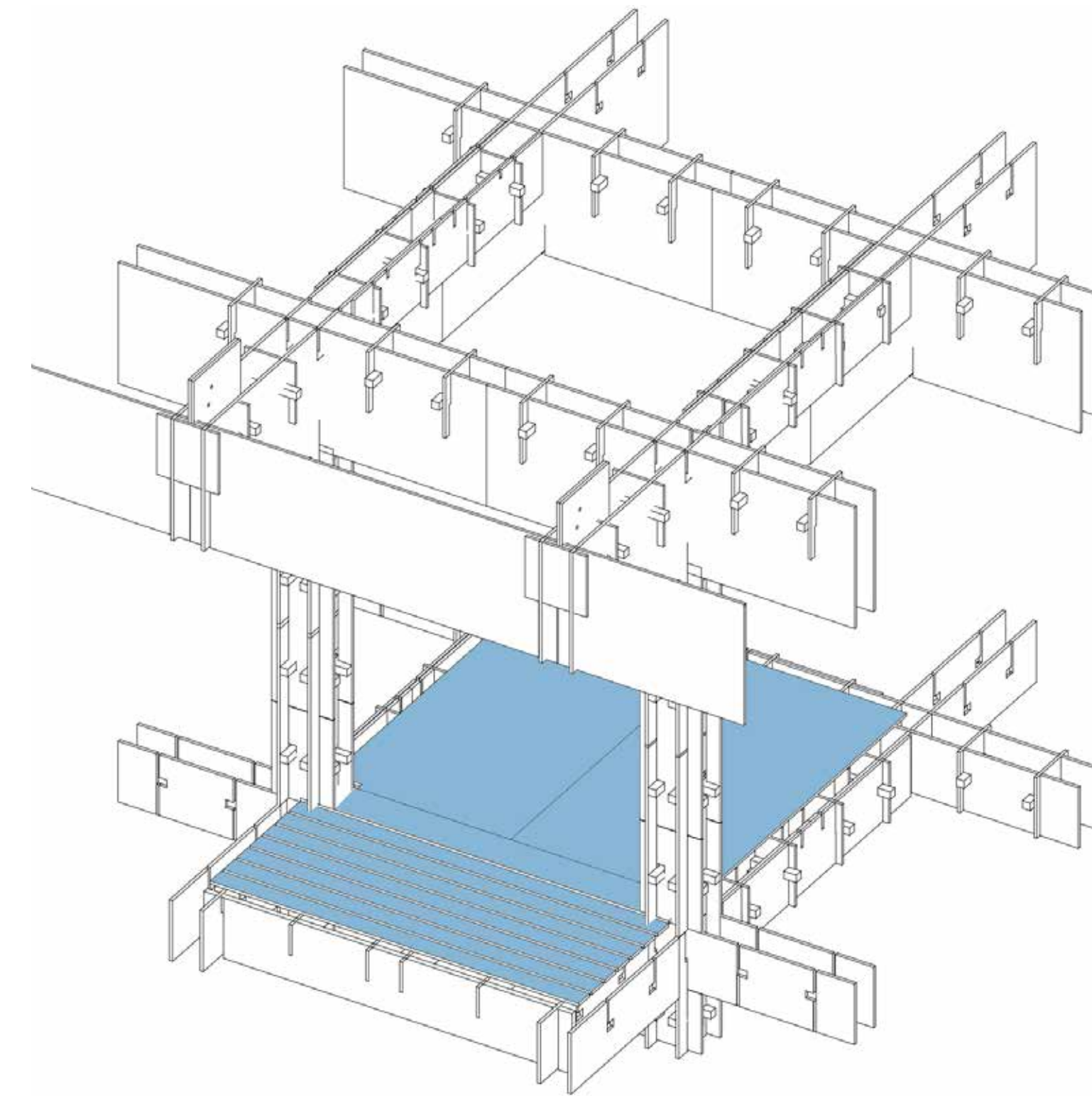
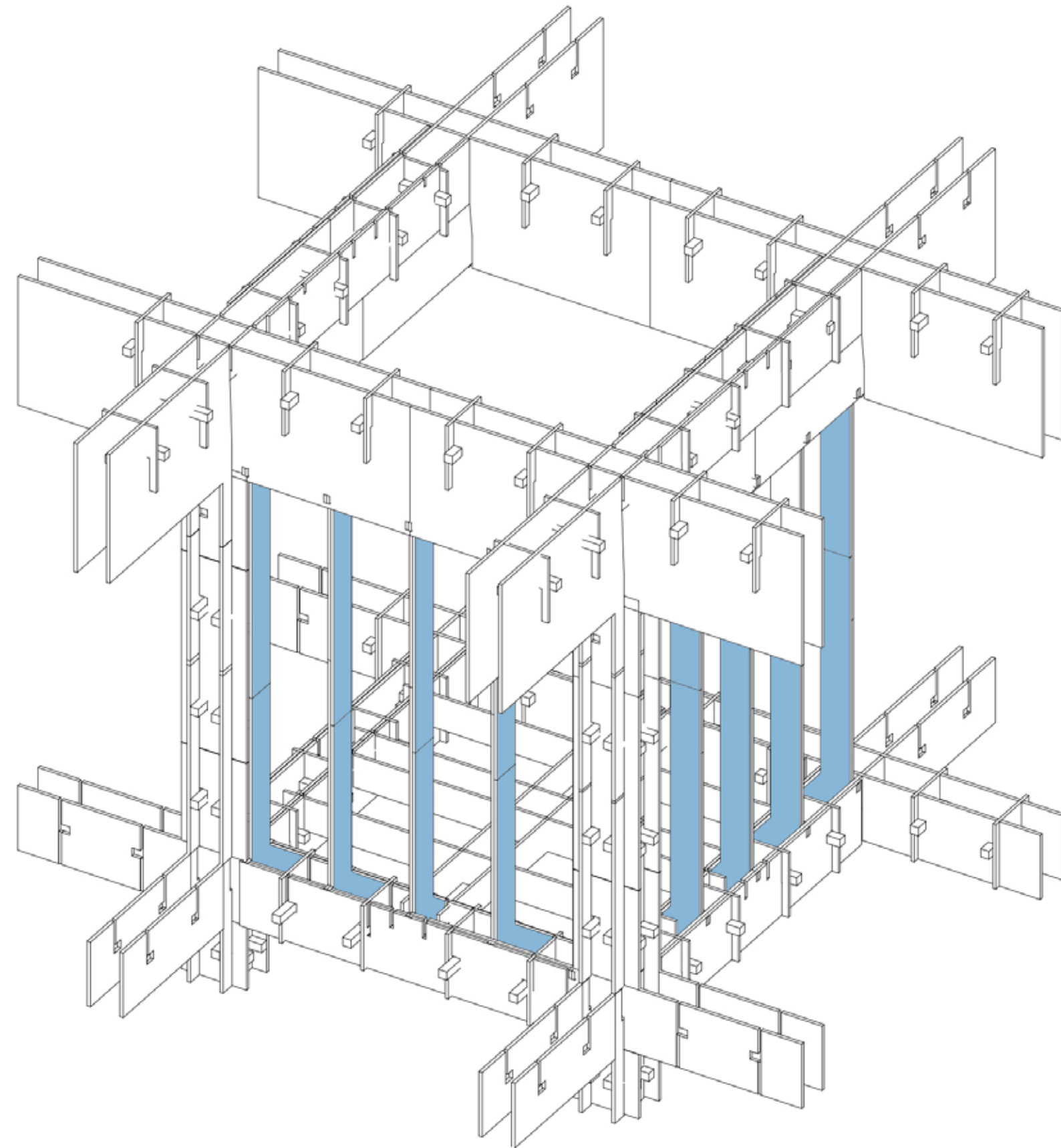
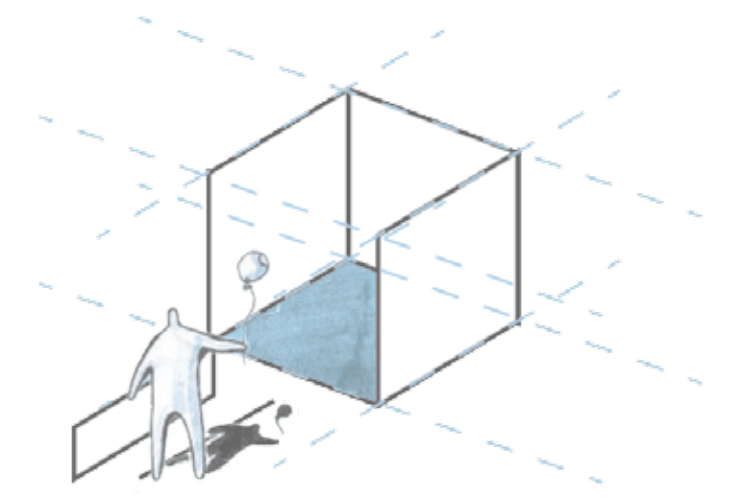

TECHNIQUE

BUILDING SYSTEM

Analysis

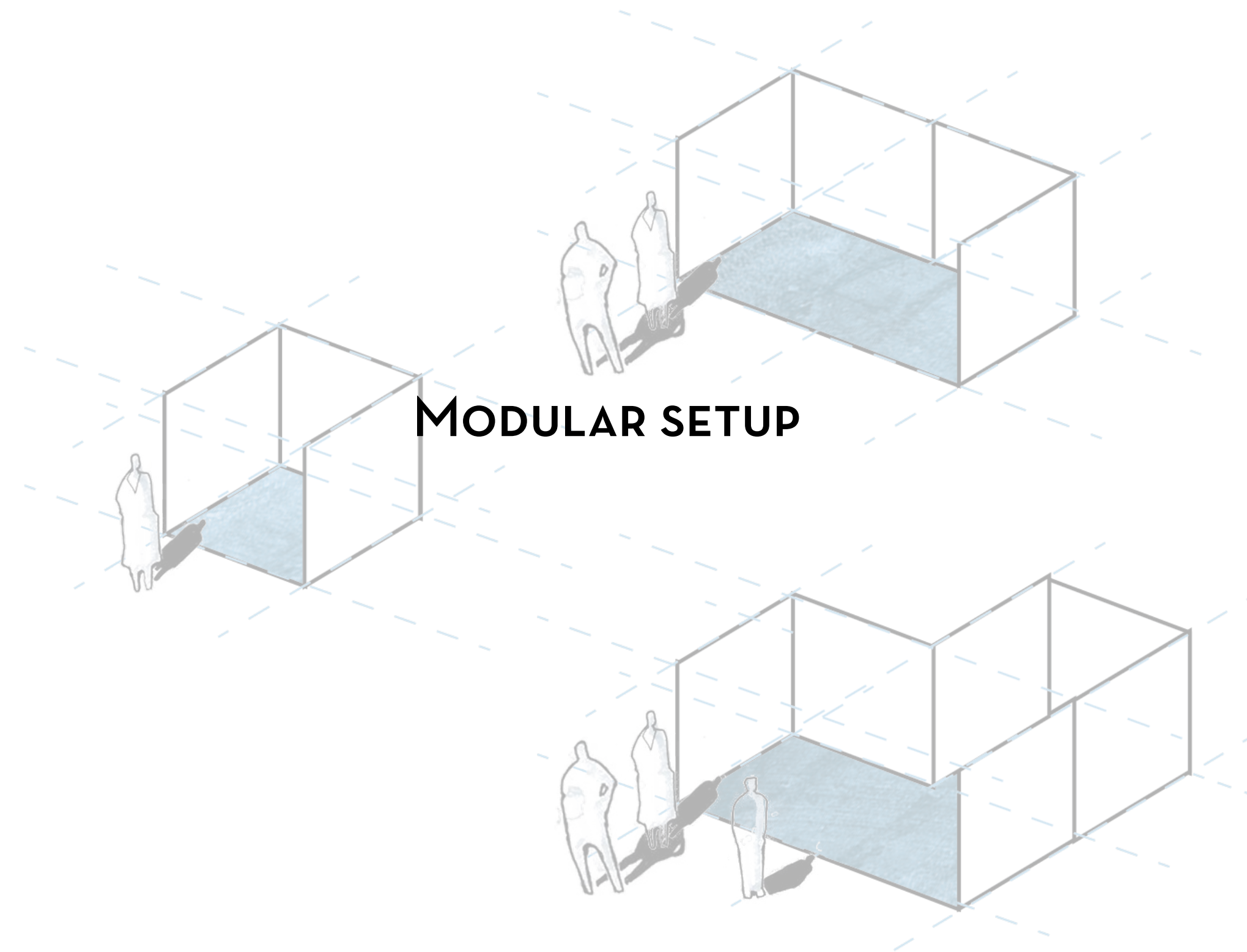

BUILDING SYSTEM

Analysis

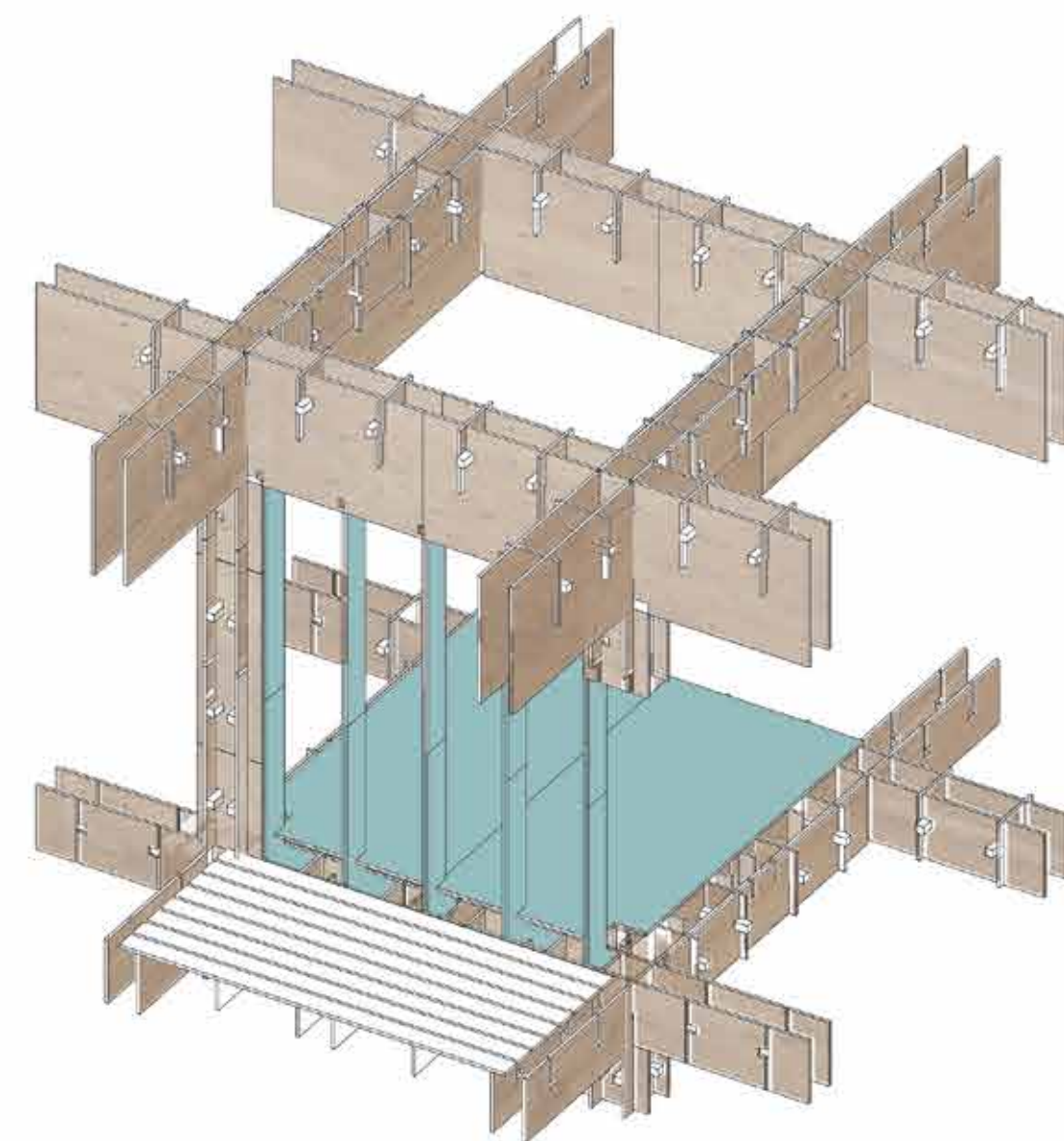
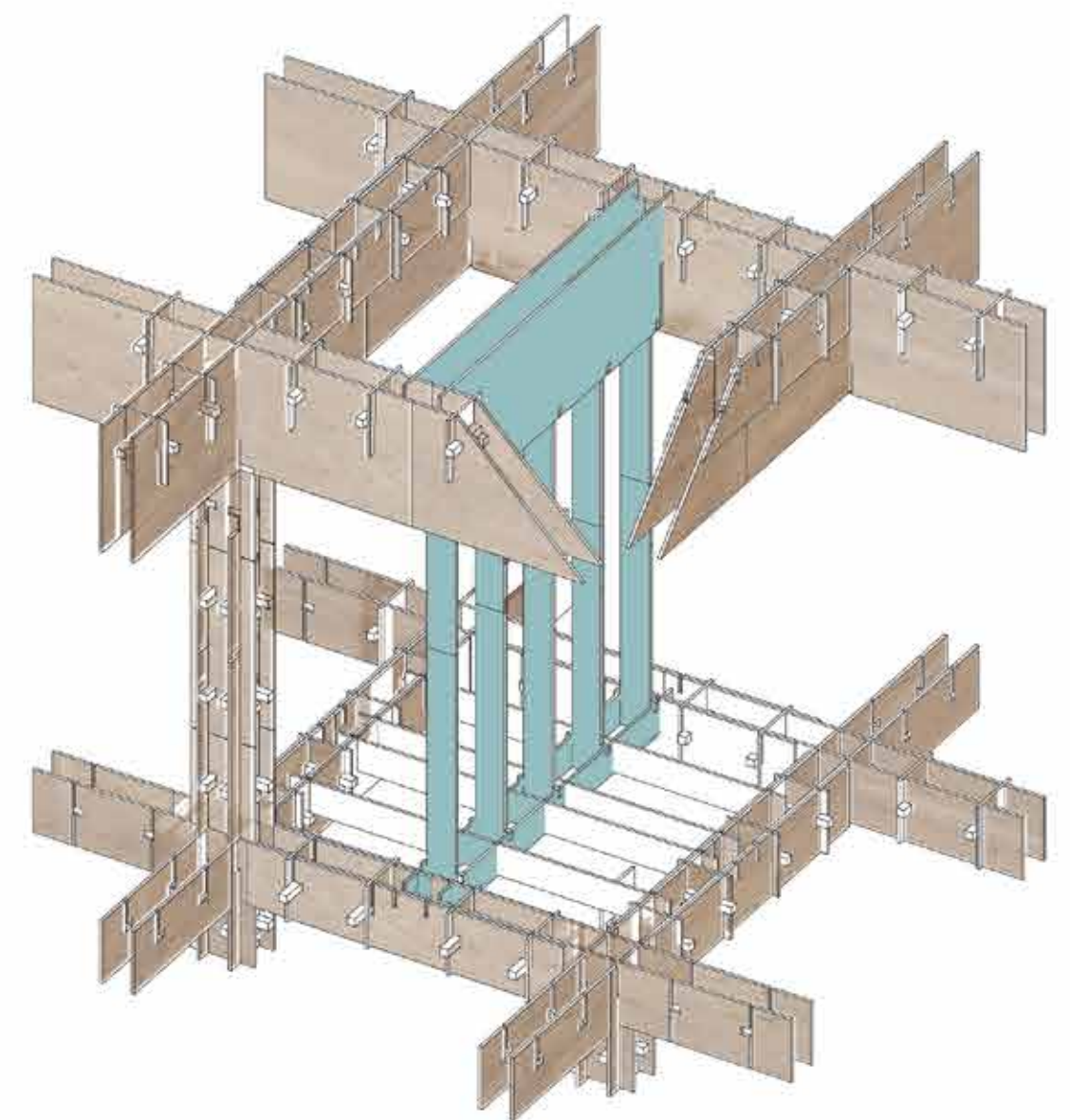
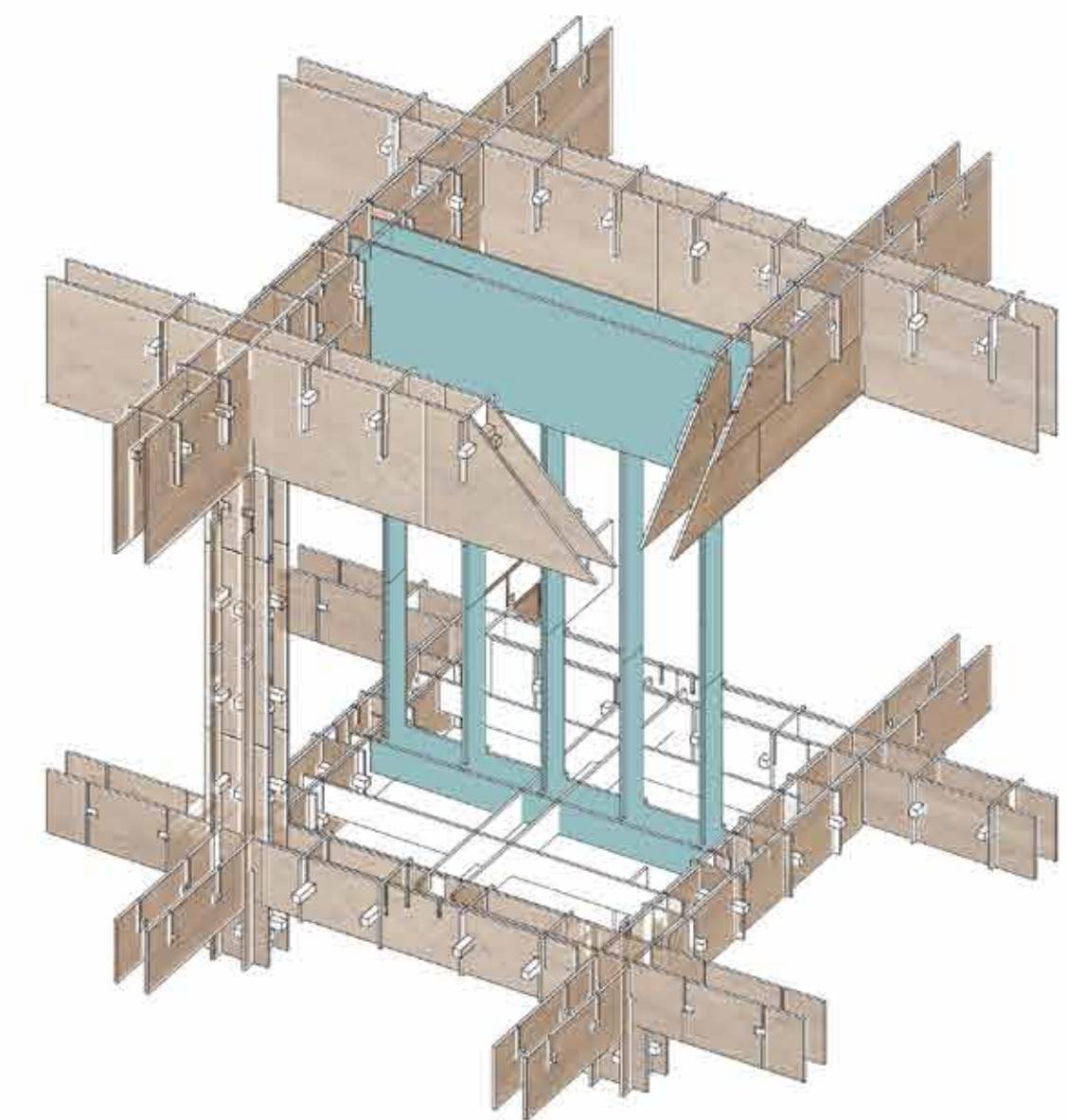
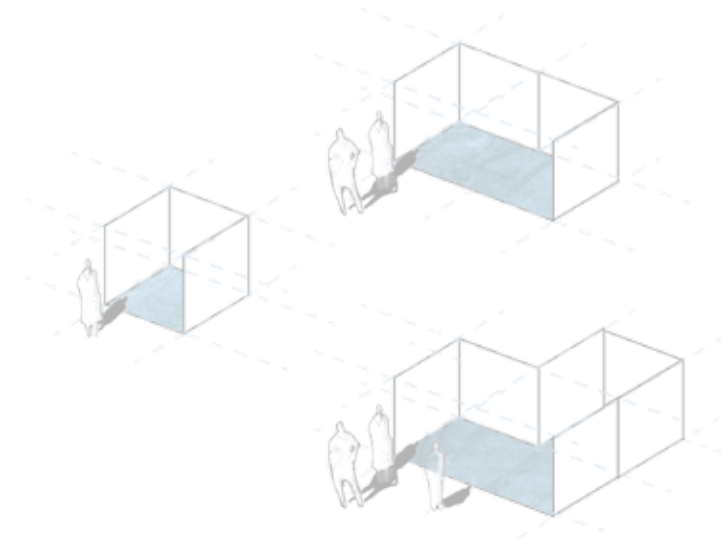

BUILDING SYSTEM

Local additions

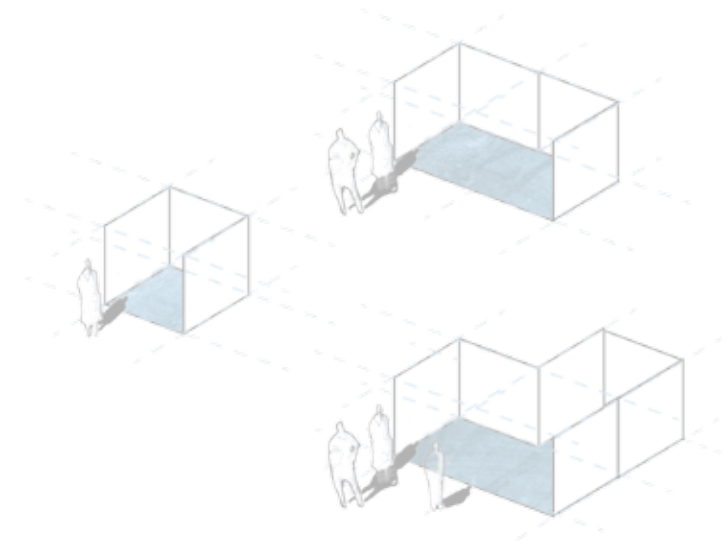

Local Craftmen can contribute by weaving the panels for the second facade.

BUILDING SYSTEM

Variation facade

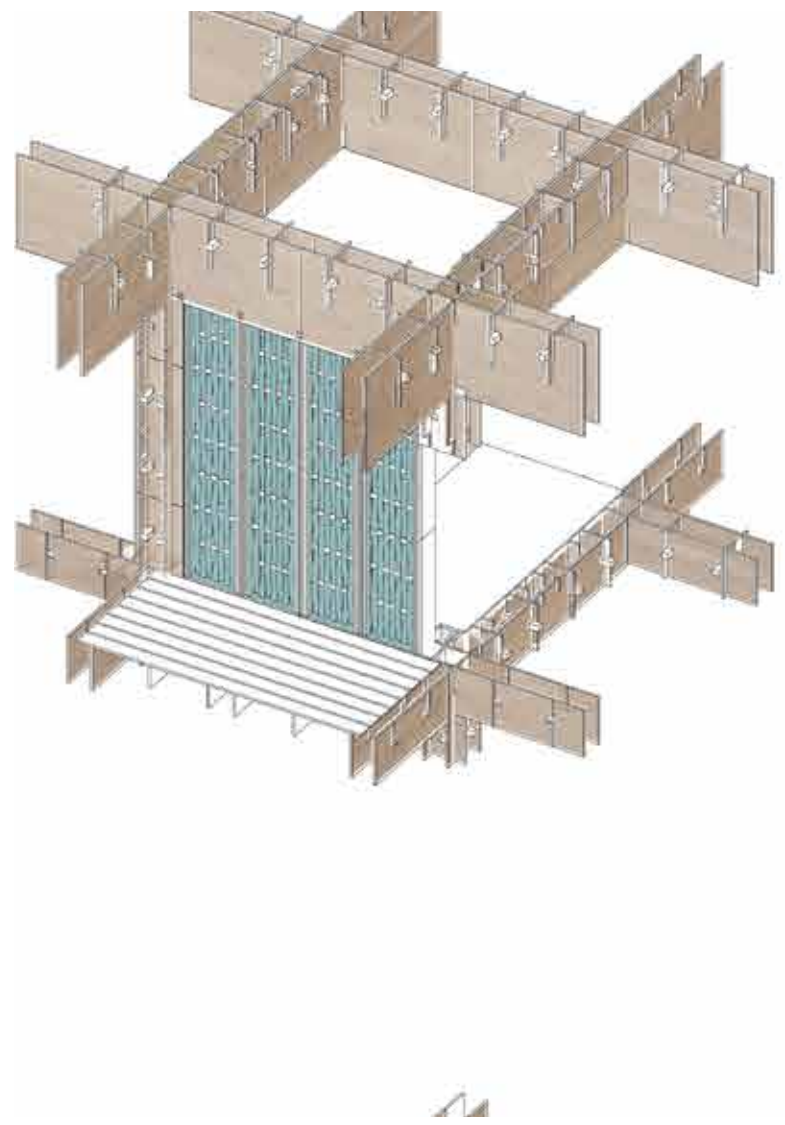
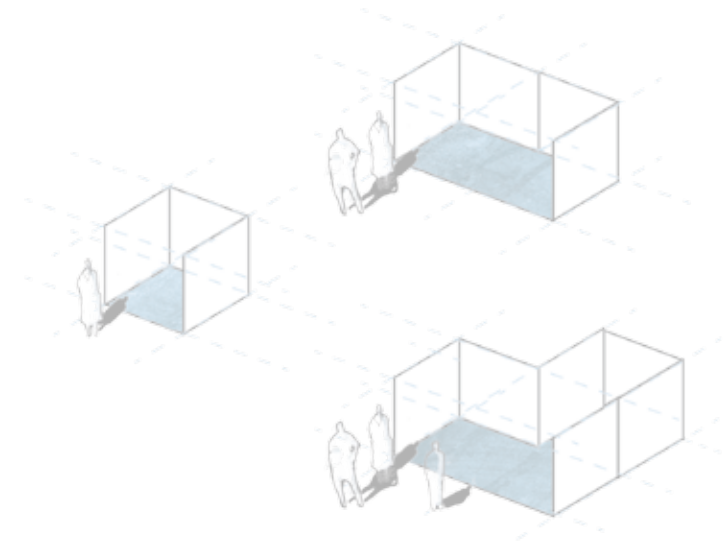

Woven bamboo panel

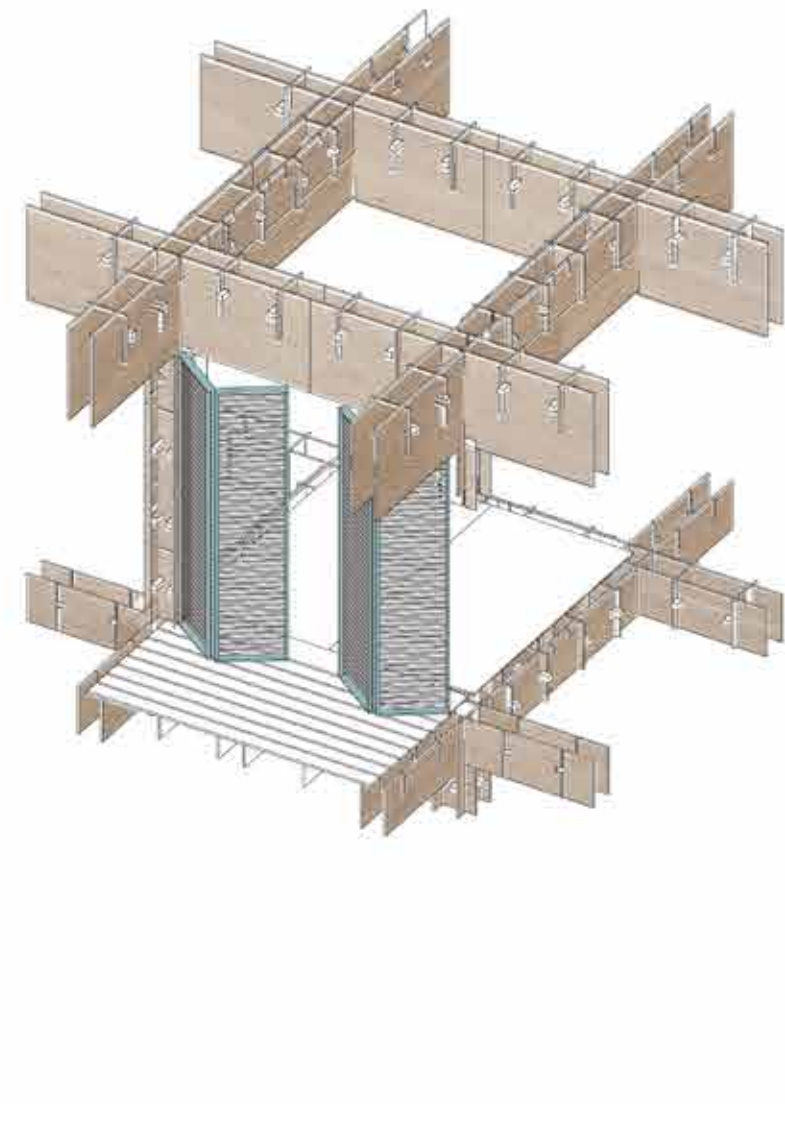

Bamboo sliding door

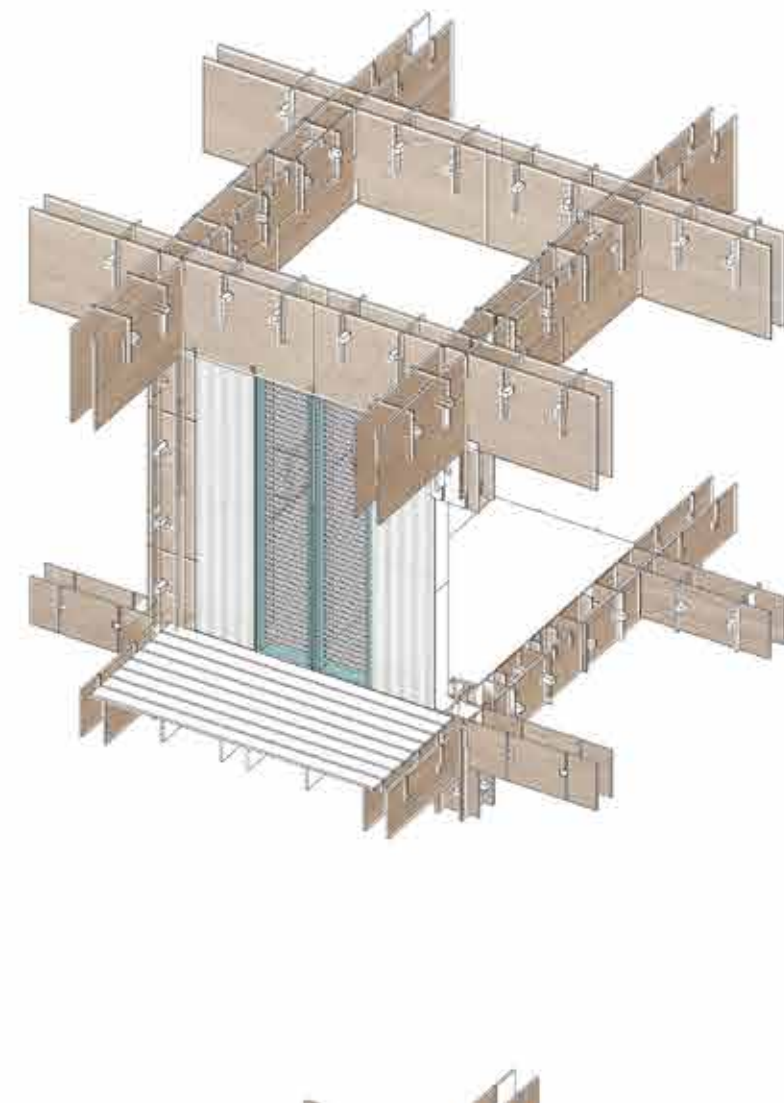

Fixed bamboo shade panel

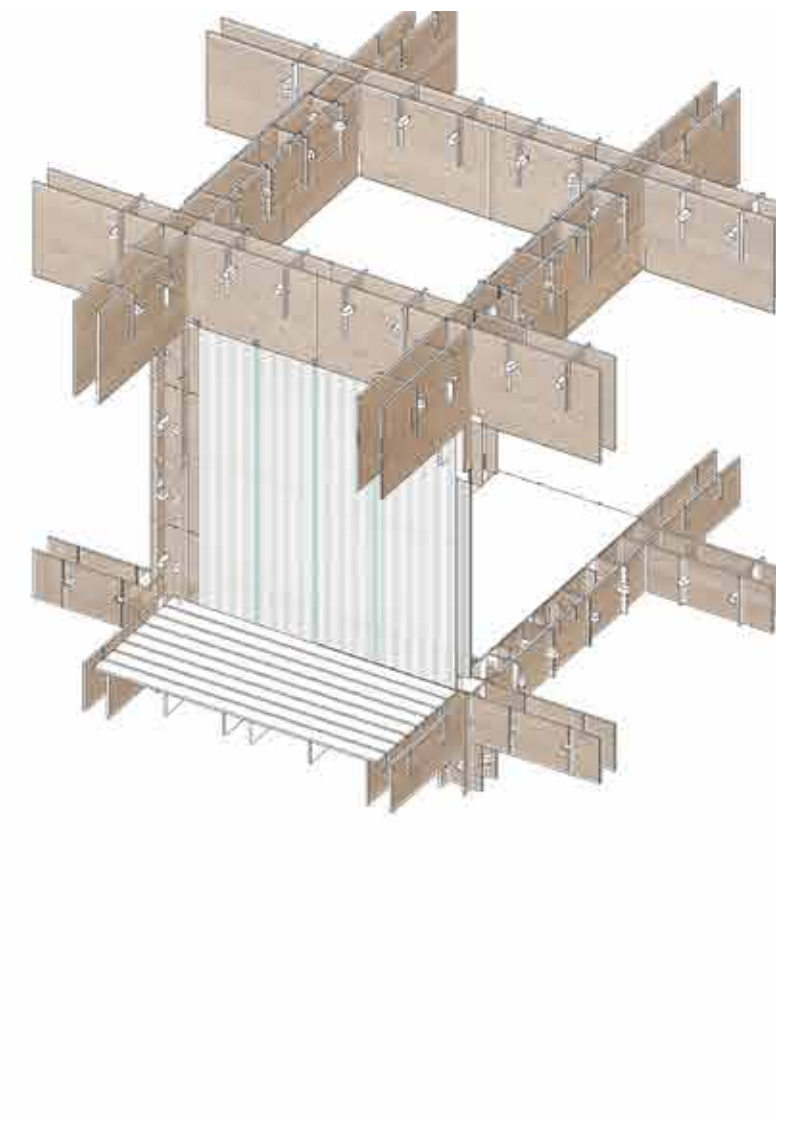

Translucent polycarbonate panel

BUILDING SYSTEM

Second facade pattern

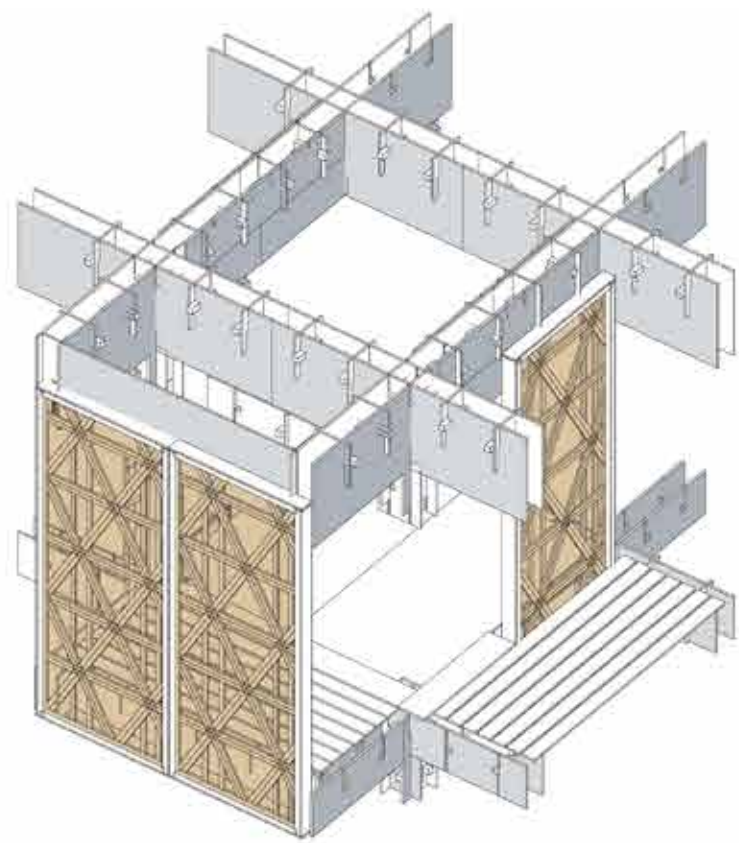
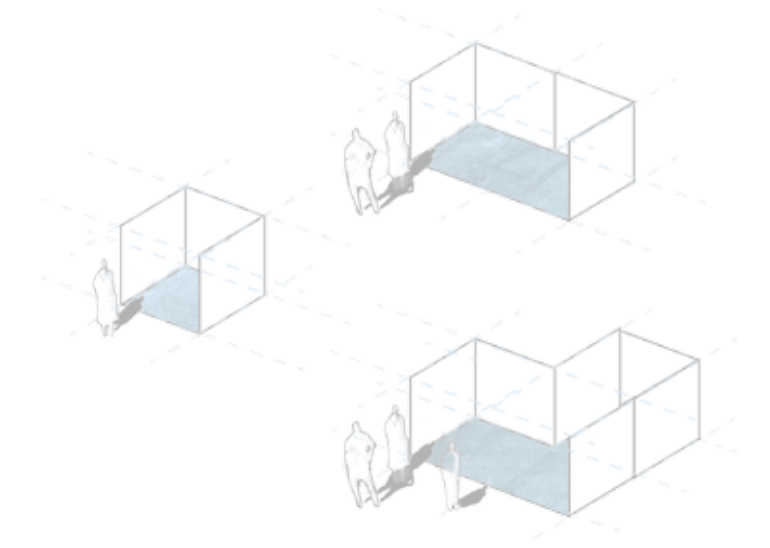

Woven bamboo panel

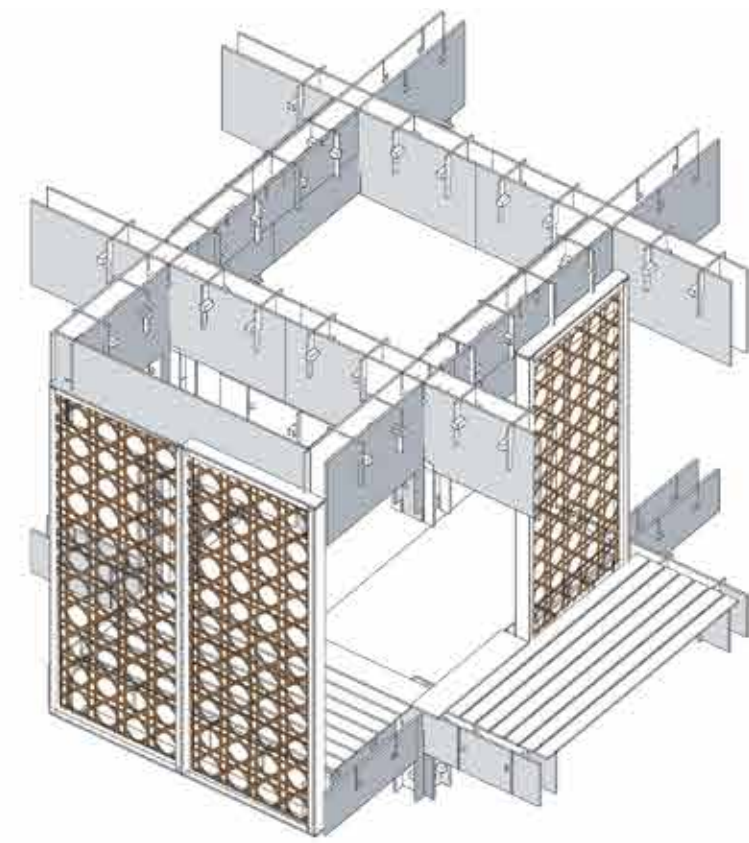

Traditional West Bengalese patterns

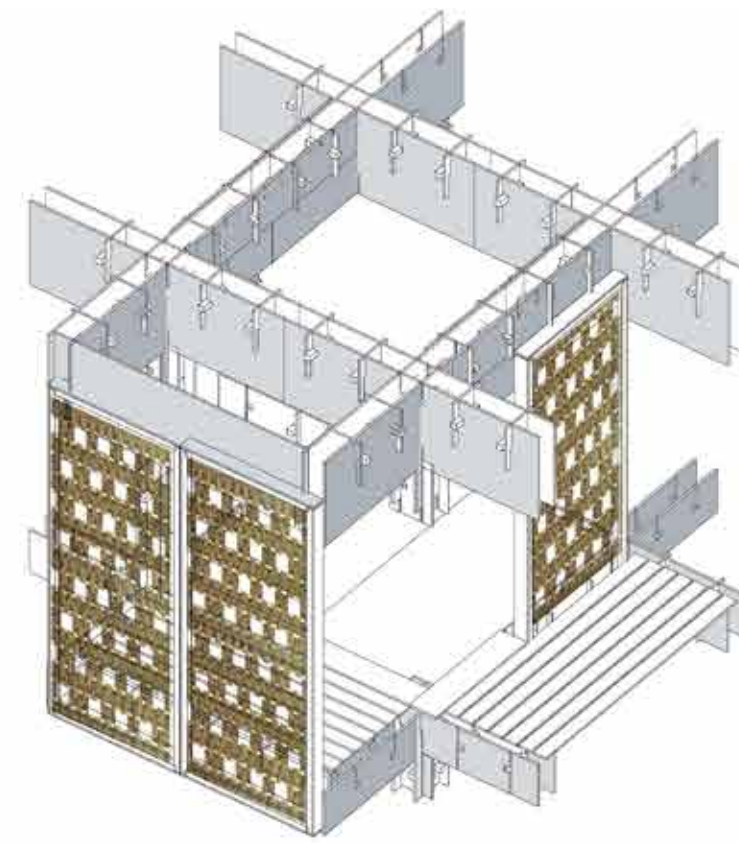

Thicker woven straw panel

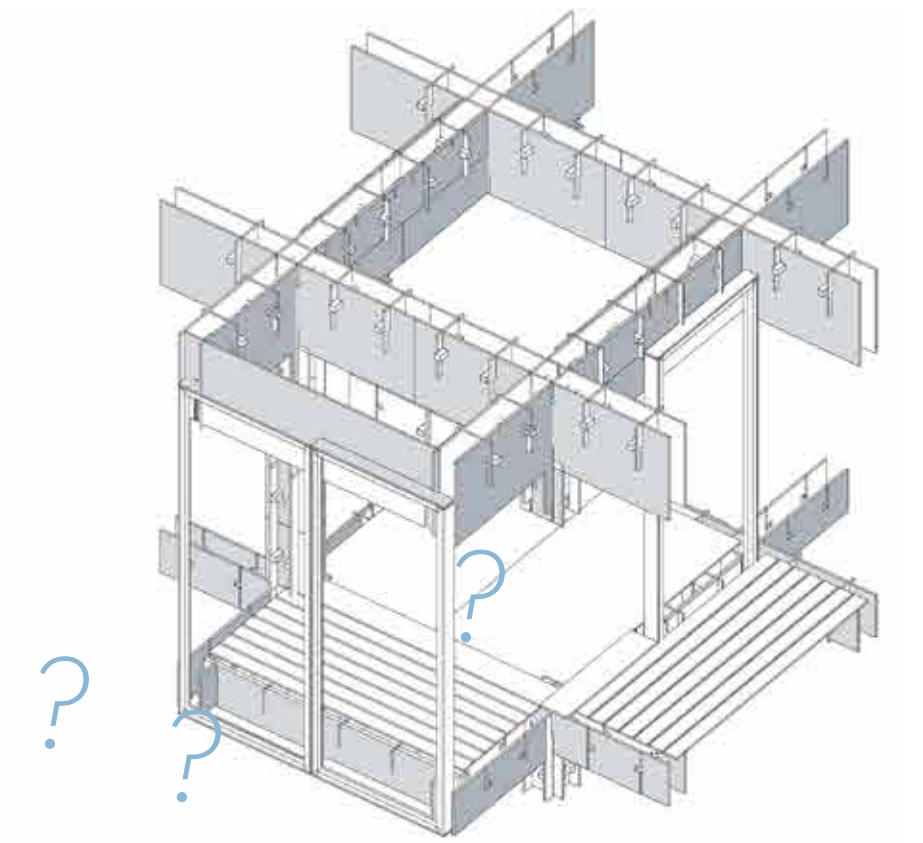

Possibility for local craftsman to contribute

BUILDING SYSTEM

Roof addition

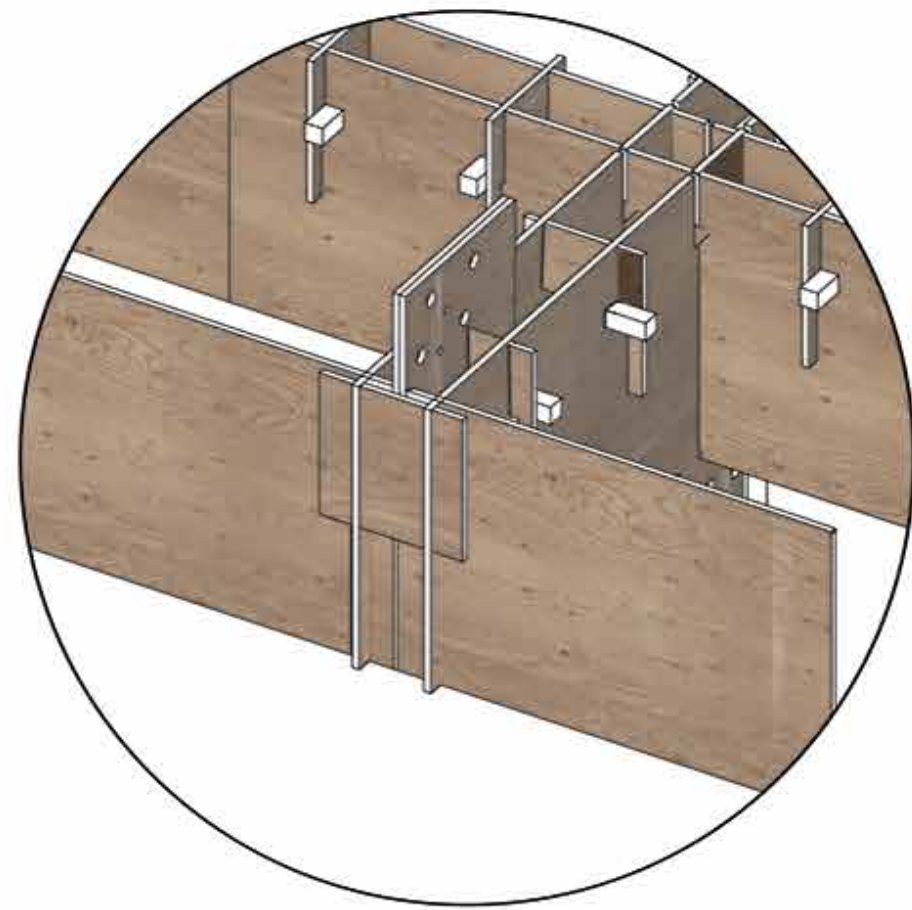
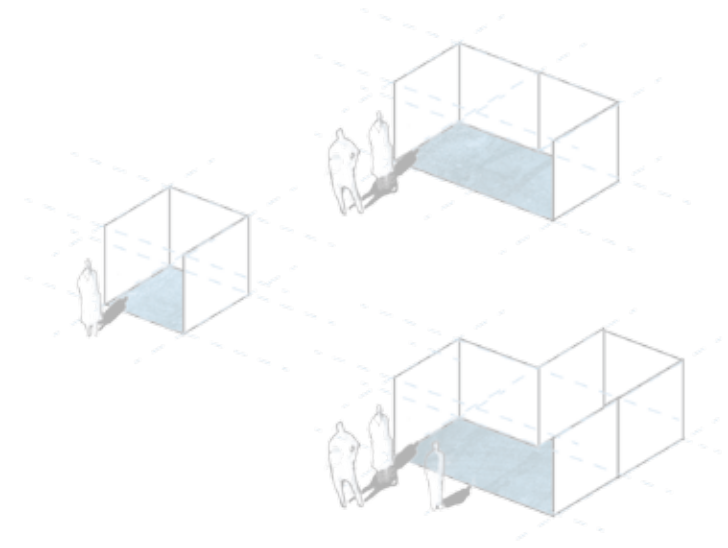

Connection point for roofing

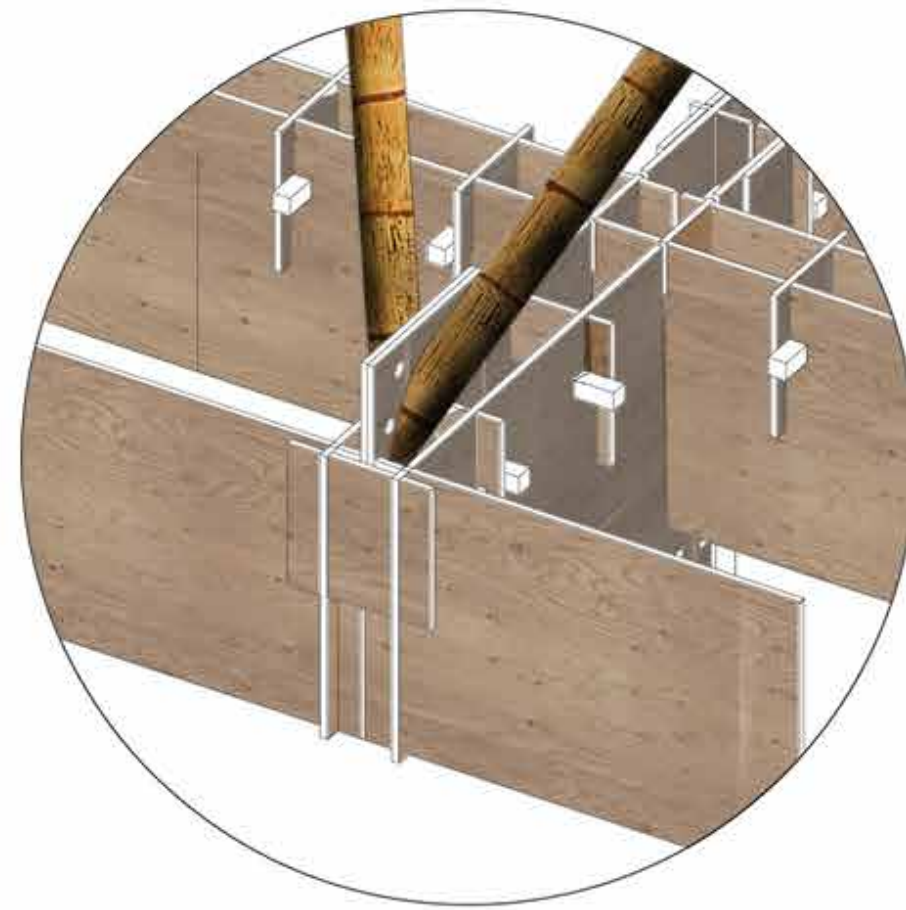

Tapered bamboo slide on plate

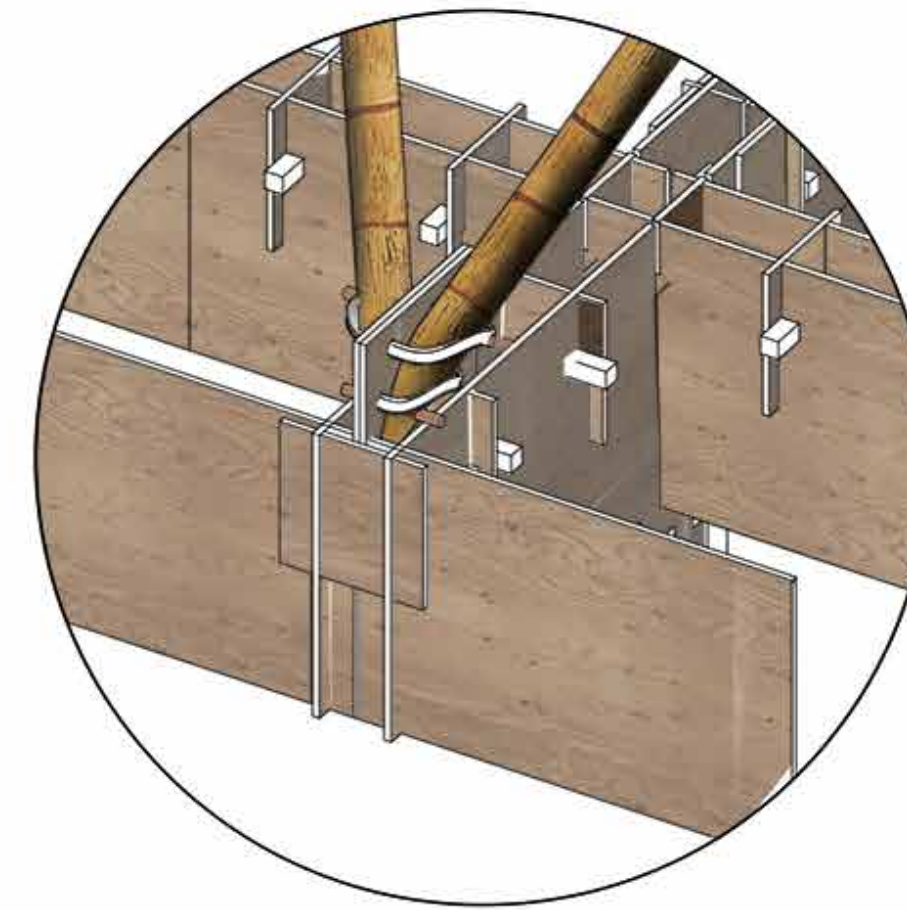

Pinned and lashed at 2 points to attach

IMPLEMENTATION

CONTEXT

Context

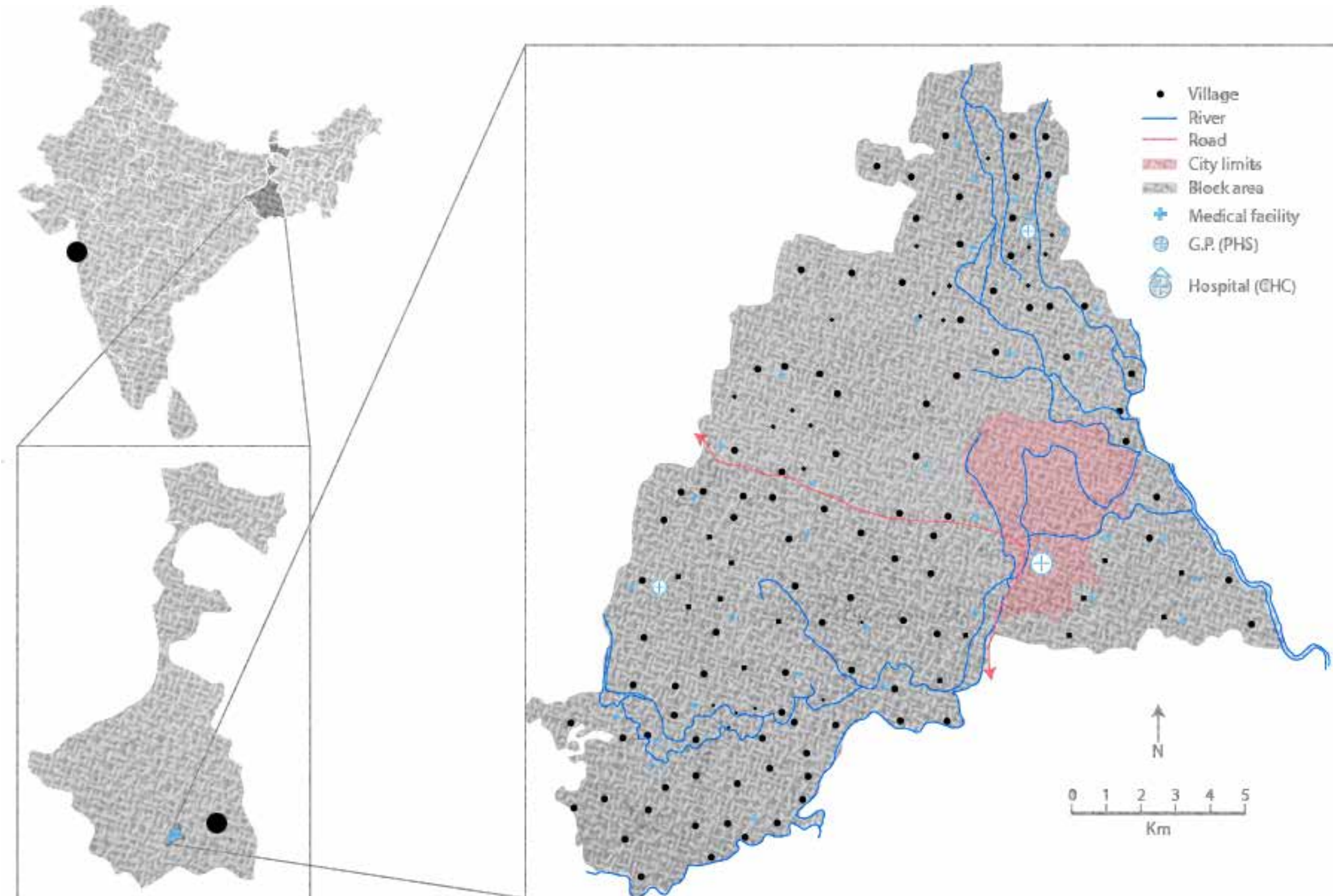

GHATAL AREA,
WEST BENGAL, INDIA

CONTEXT

Overview

Inhabitants
219,555

Children
25564 age 0-6

Primary occupation
Farming

Land area
216 km²

Literacy
81%

Income average
15,200 Rp (€ 189,86)

Religion

Tropical Region

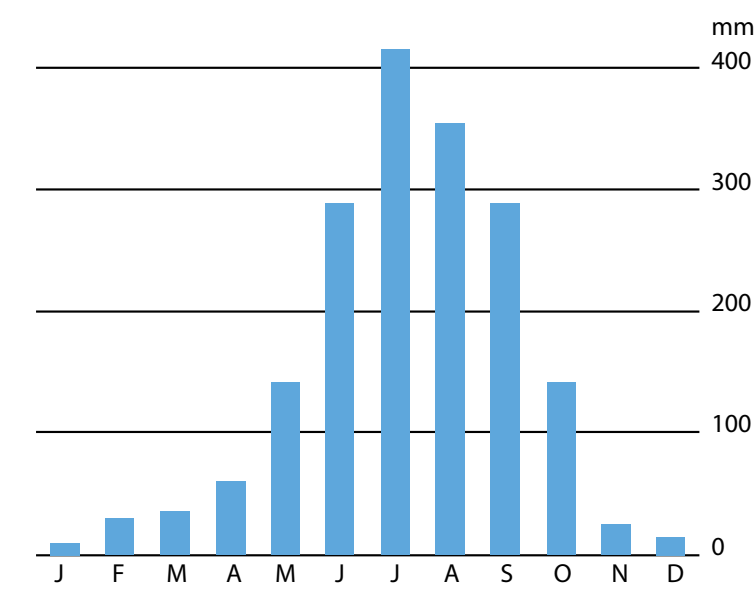

Rainfall

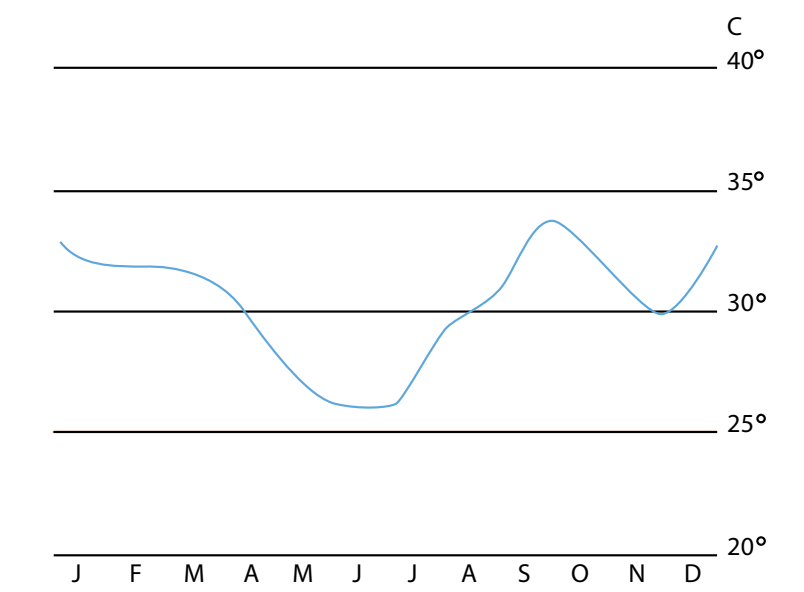

Temperature

FACTS

CLIMATE

CONTEXT

Needs - facilities

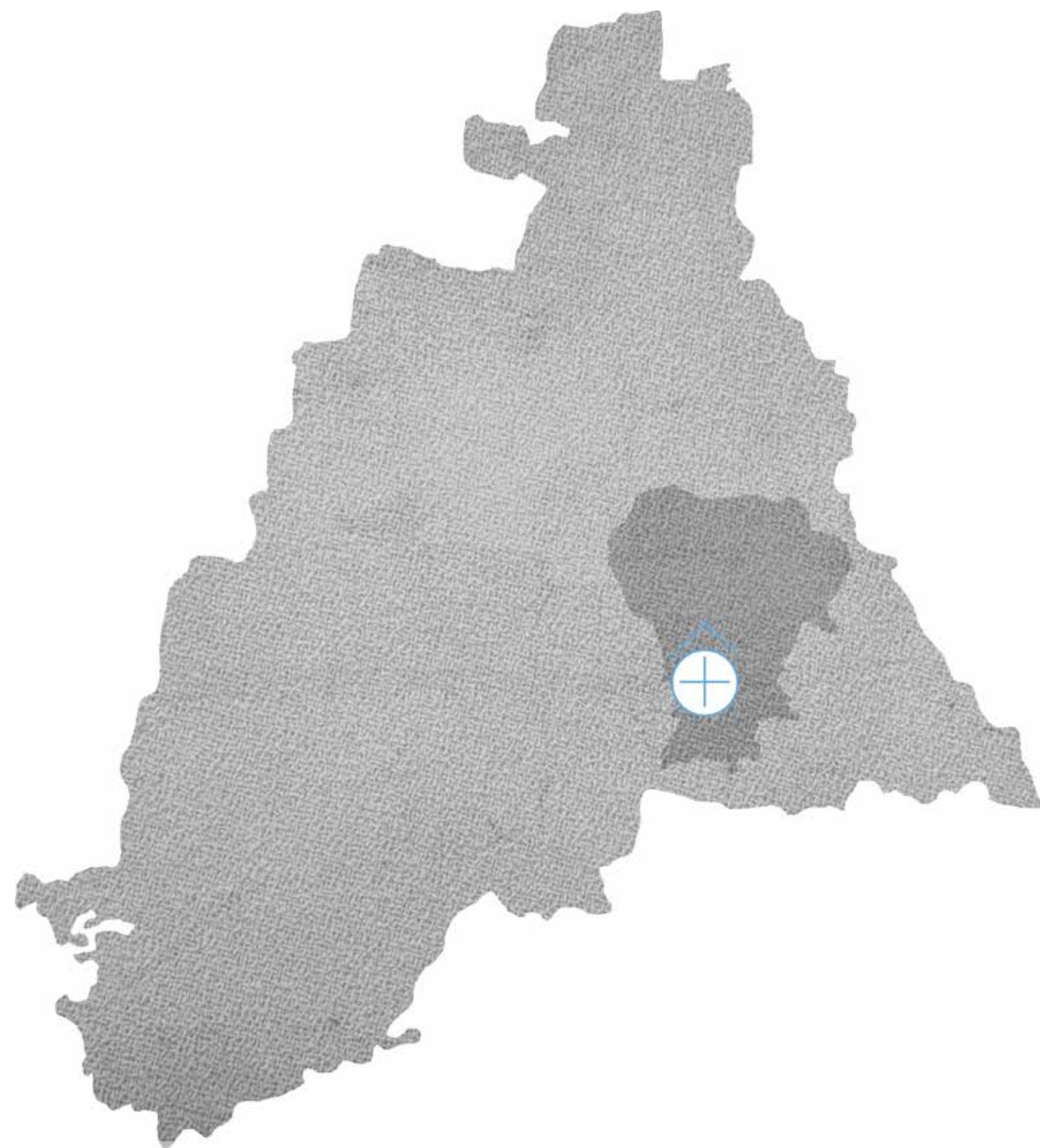

SUBDIVISION HOSPITAL

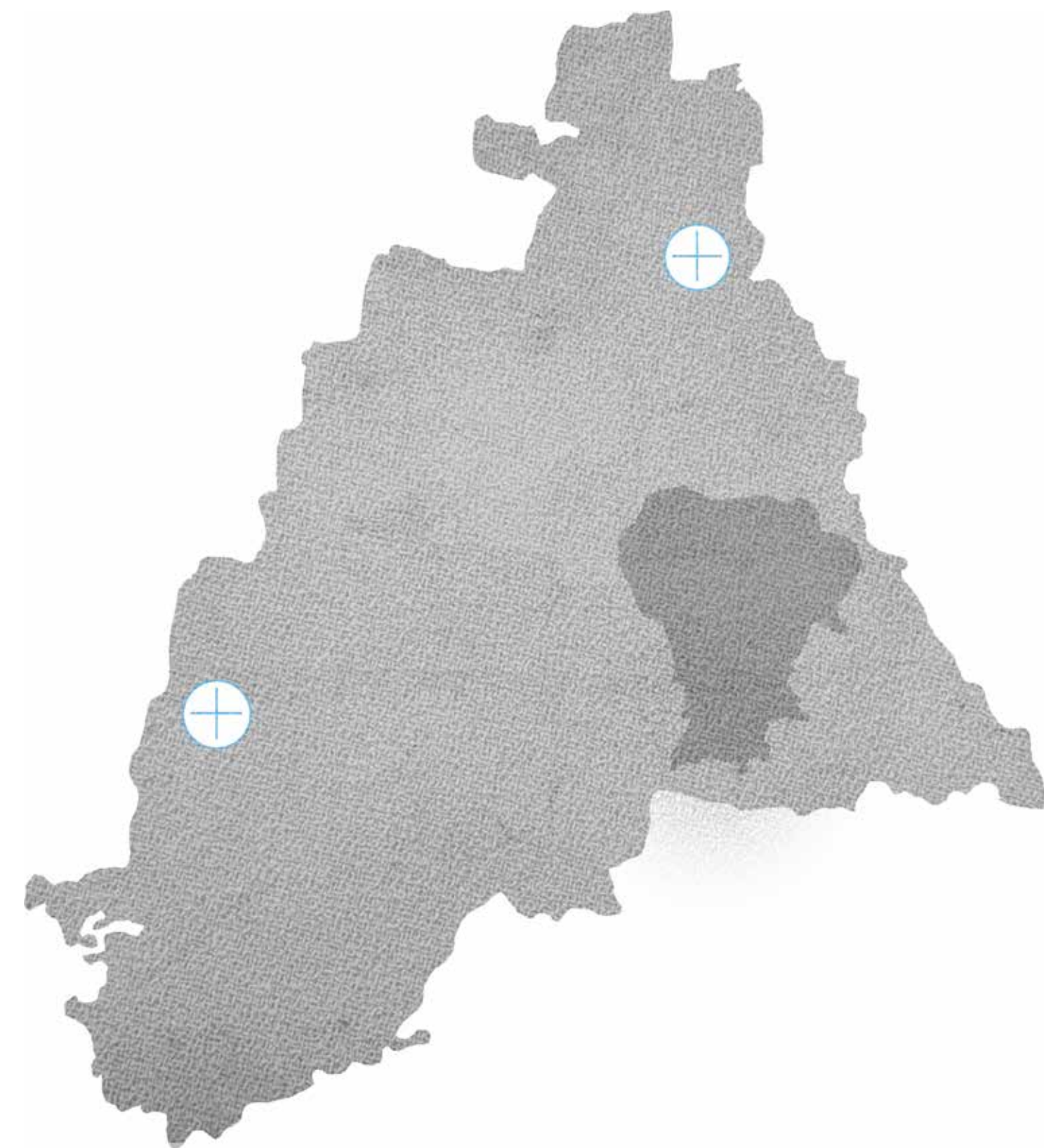

GENERAL PRACTITIONERS

CONTEXT

Needs - medical care

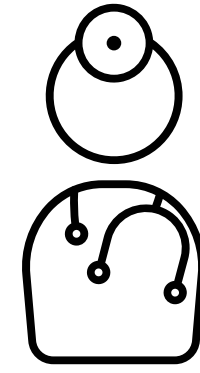

*General
care*

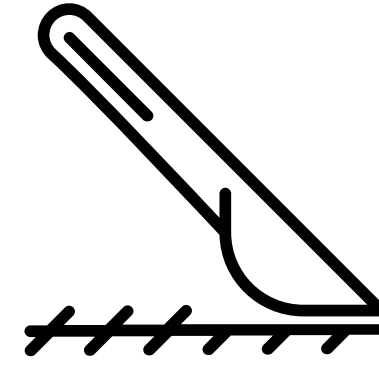

*Small
Procedures*

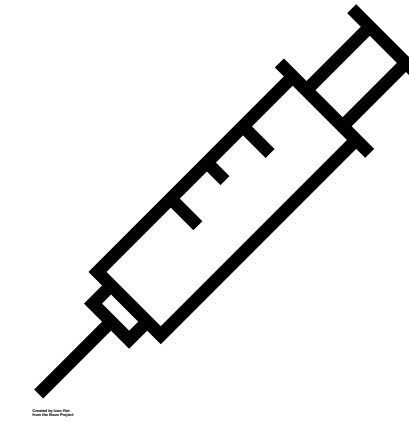

Immunization

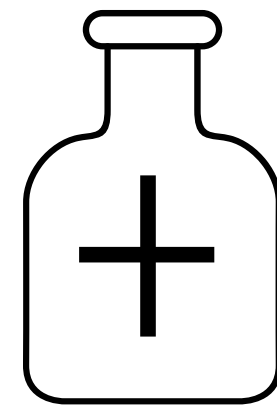

Basic medicines

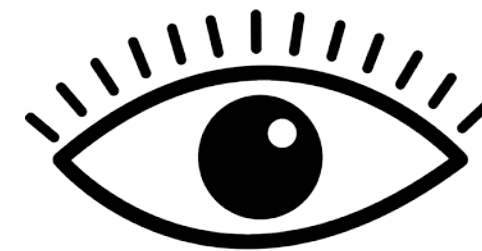

Eye care

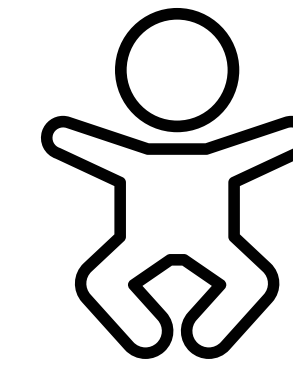

*Birth control /
Maternity*

CONTEXT

flooding

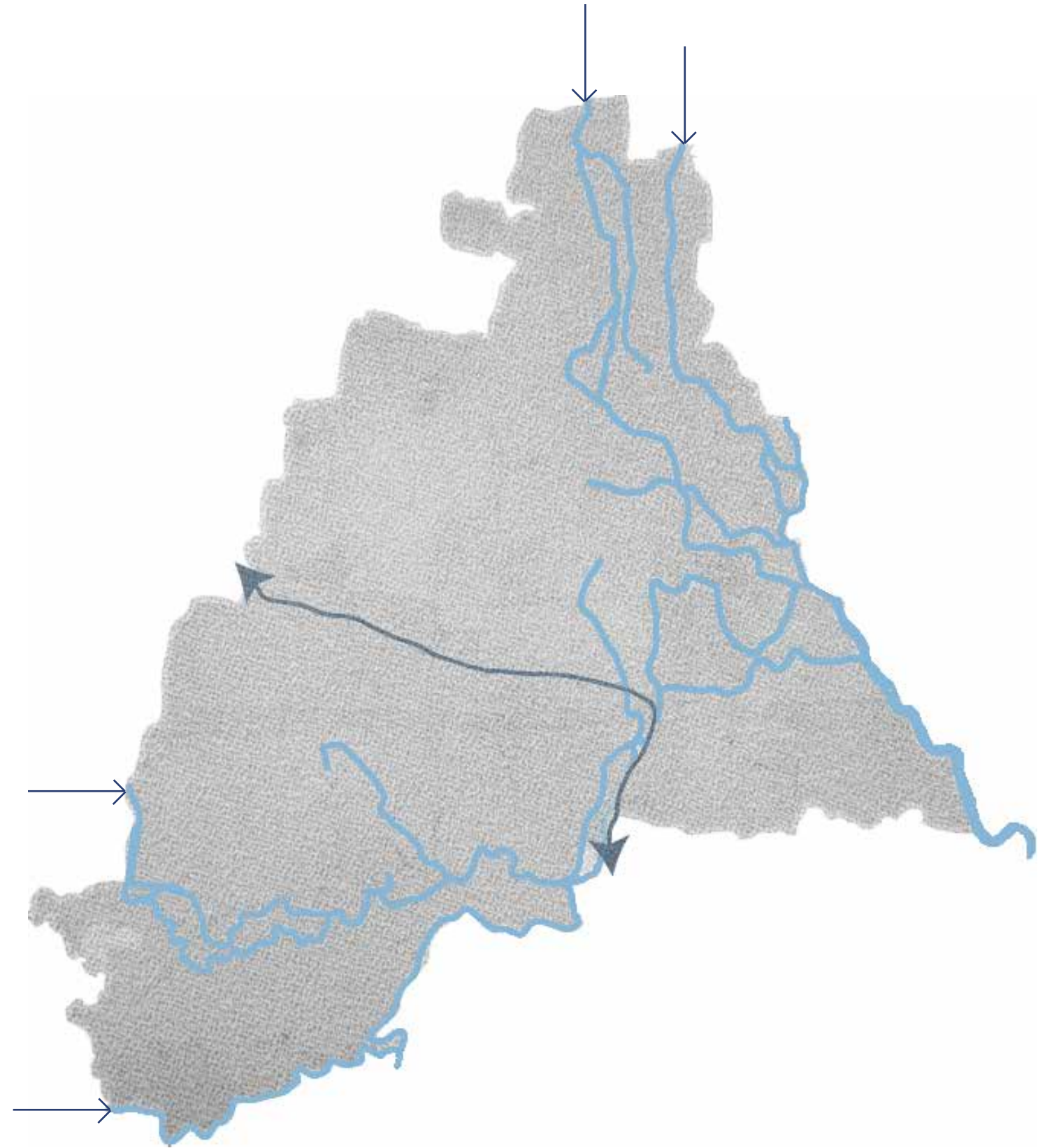

Dry Season

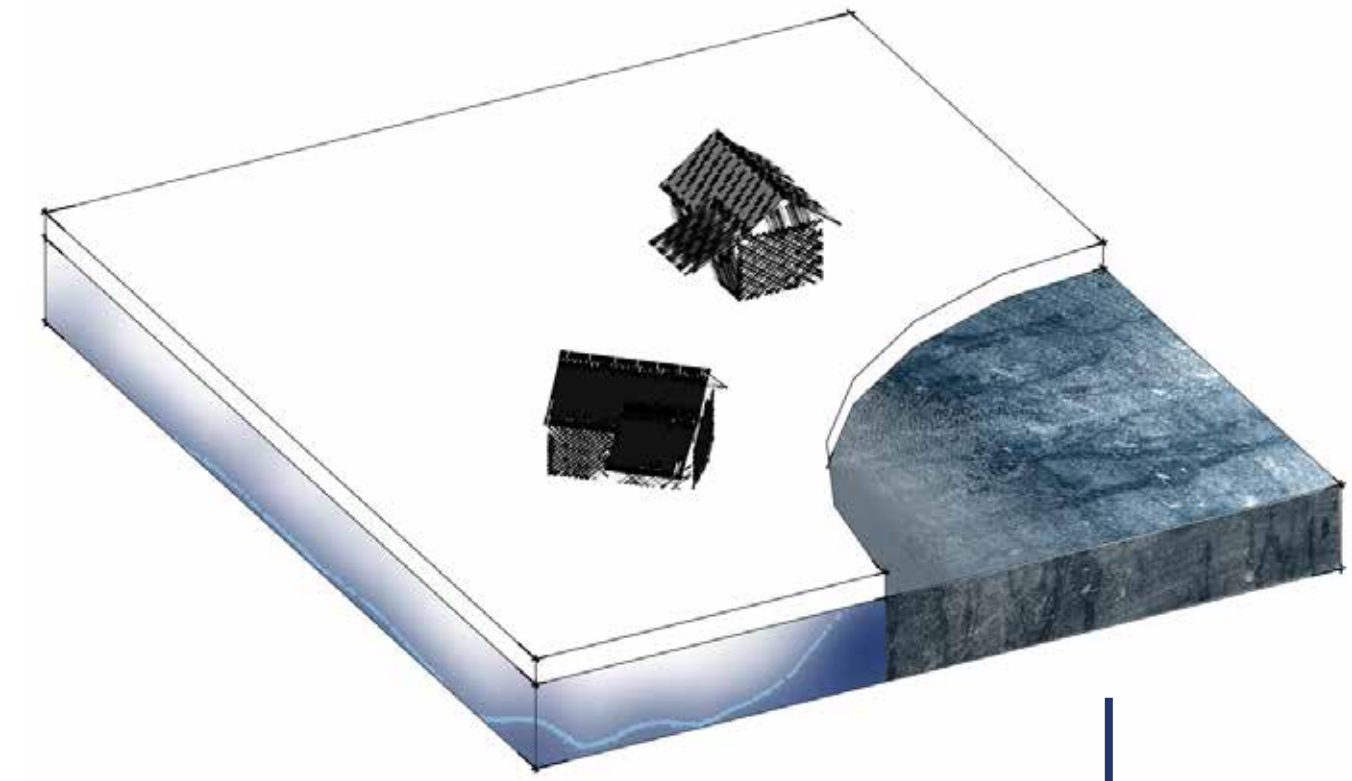

Monsoon

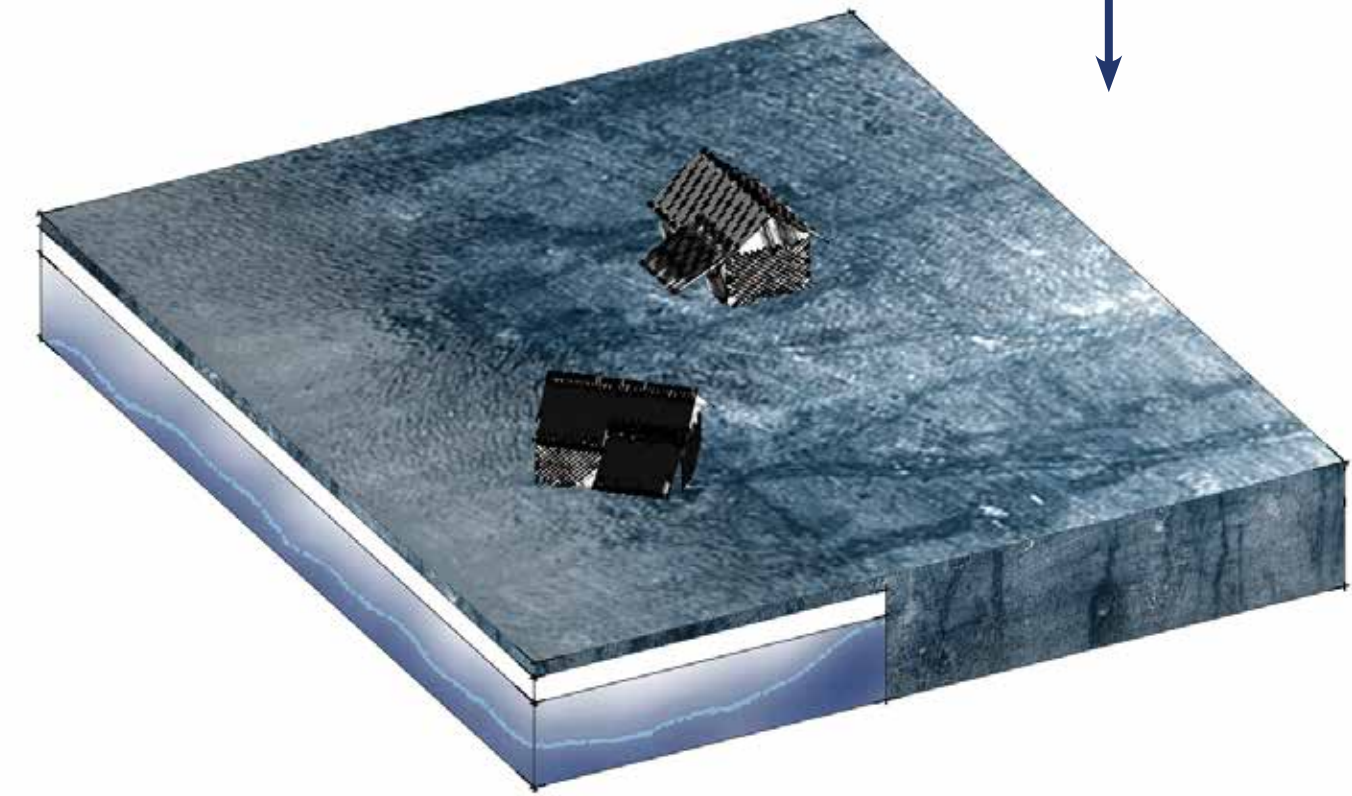

CONTEXT

flooding



FLOODING RESULT

EXAMPLE SITE

EXAMPLE SITE

Analysis

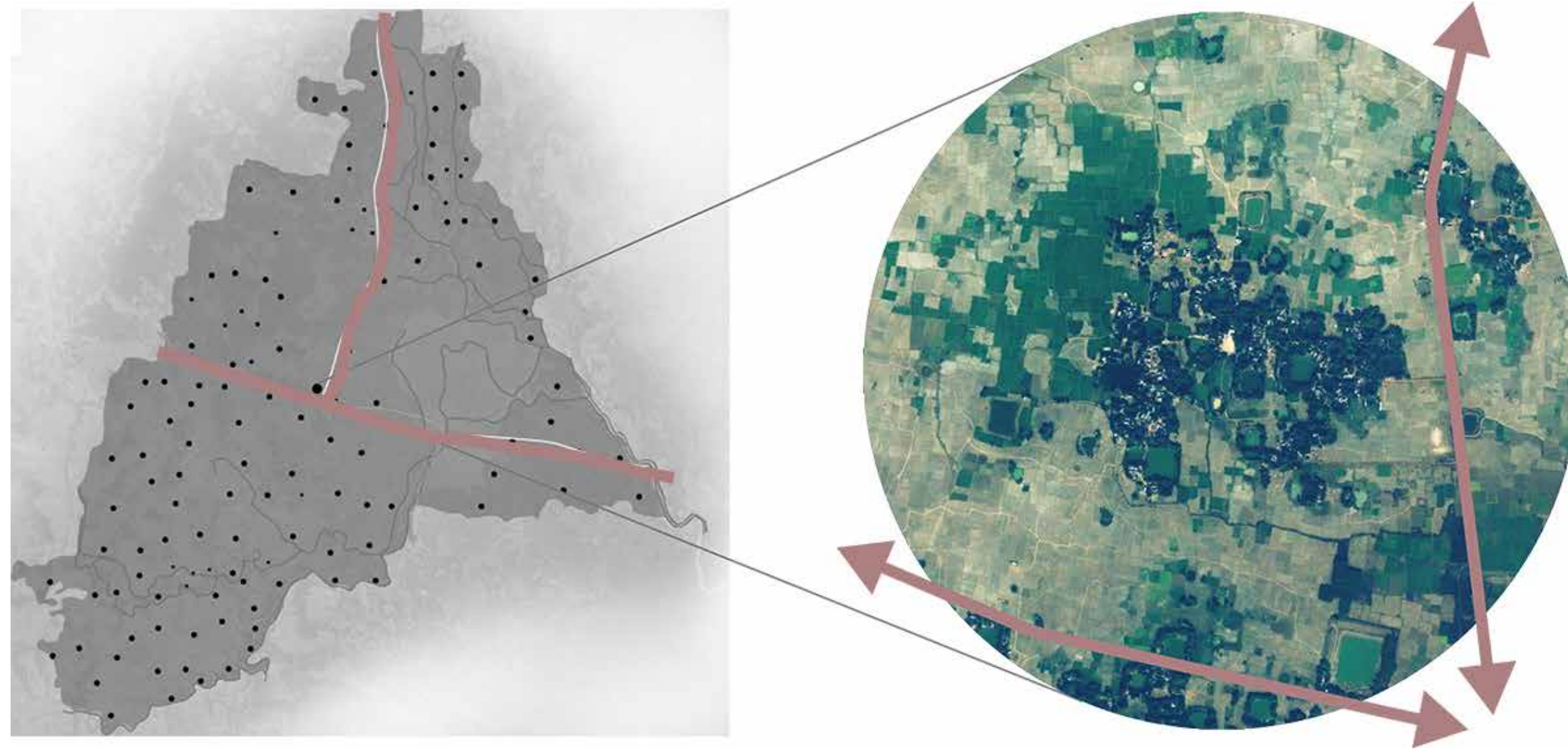

Village Marichya

Population: 10.500
Main profession: Agriculture
School: No
Medical facility: No

EXAMPLE SITE

Analysis



HOUSING SITUATION



DOCTORS VISIT

RESEARCH

Context - vernacular



Houses



Clusters

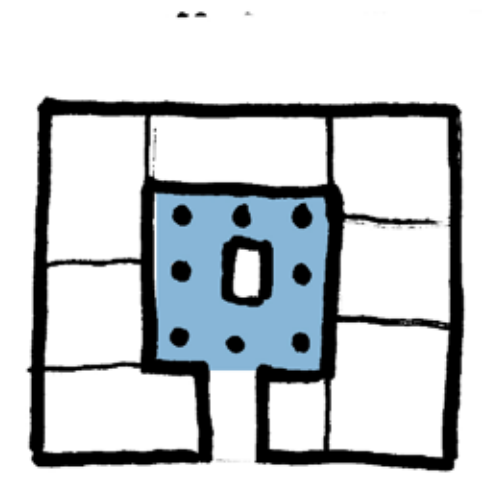
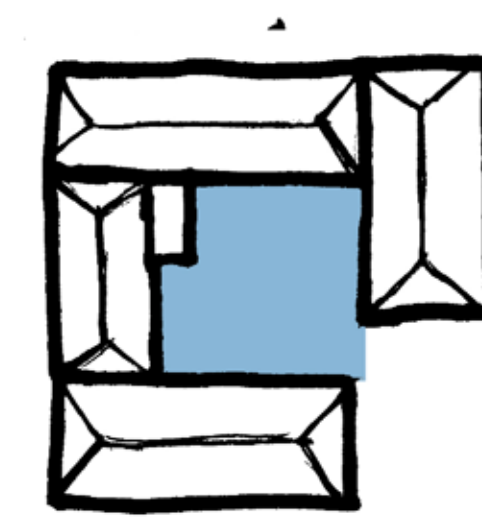
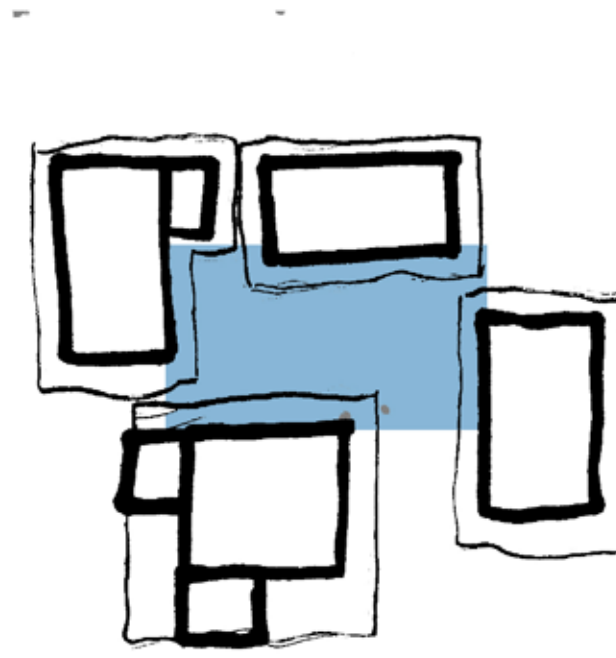

Courtyards

EXAMPLE SITE

Analysis

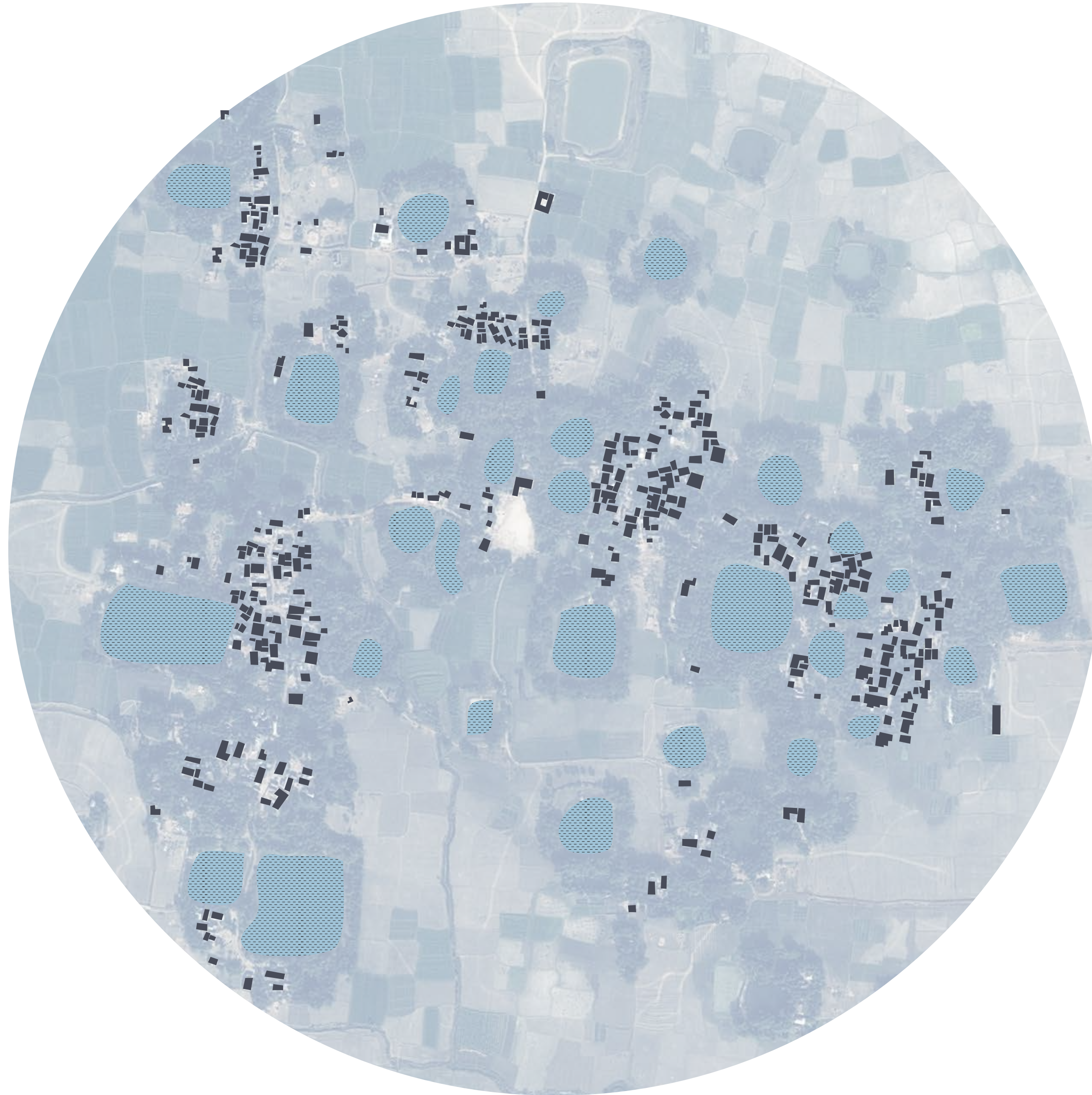

VILLAGE LAYOUT

EXAMPLE SITE

Analysis

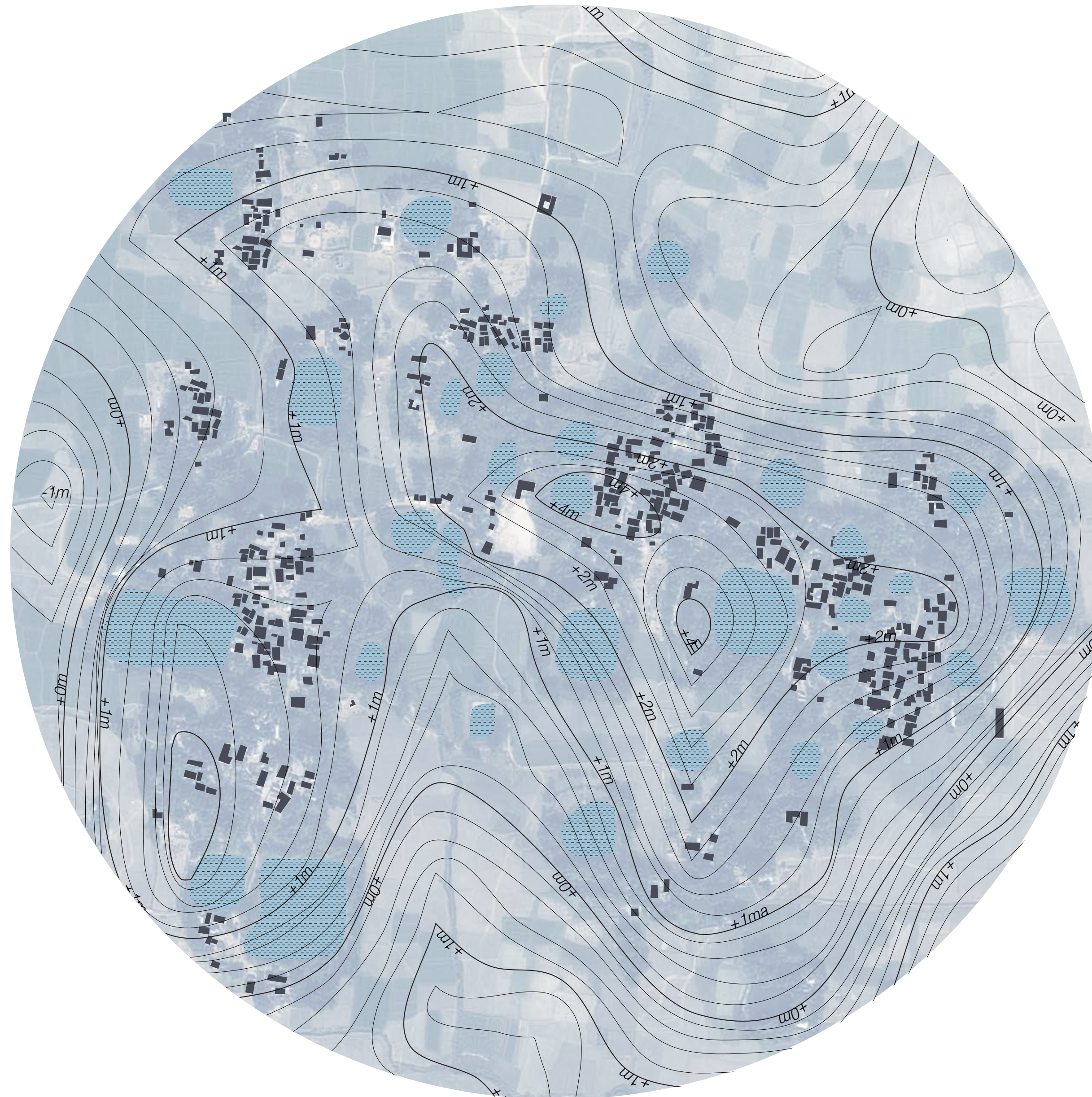

CLUSTERS ON HIGHER GROUND

EXAMPLE SITE

Analysis

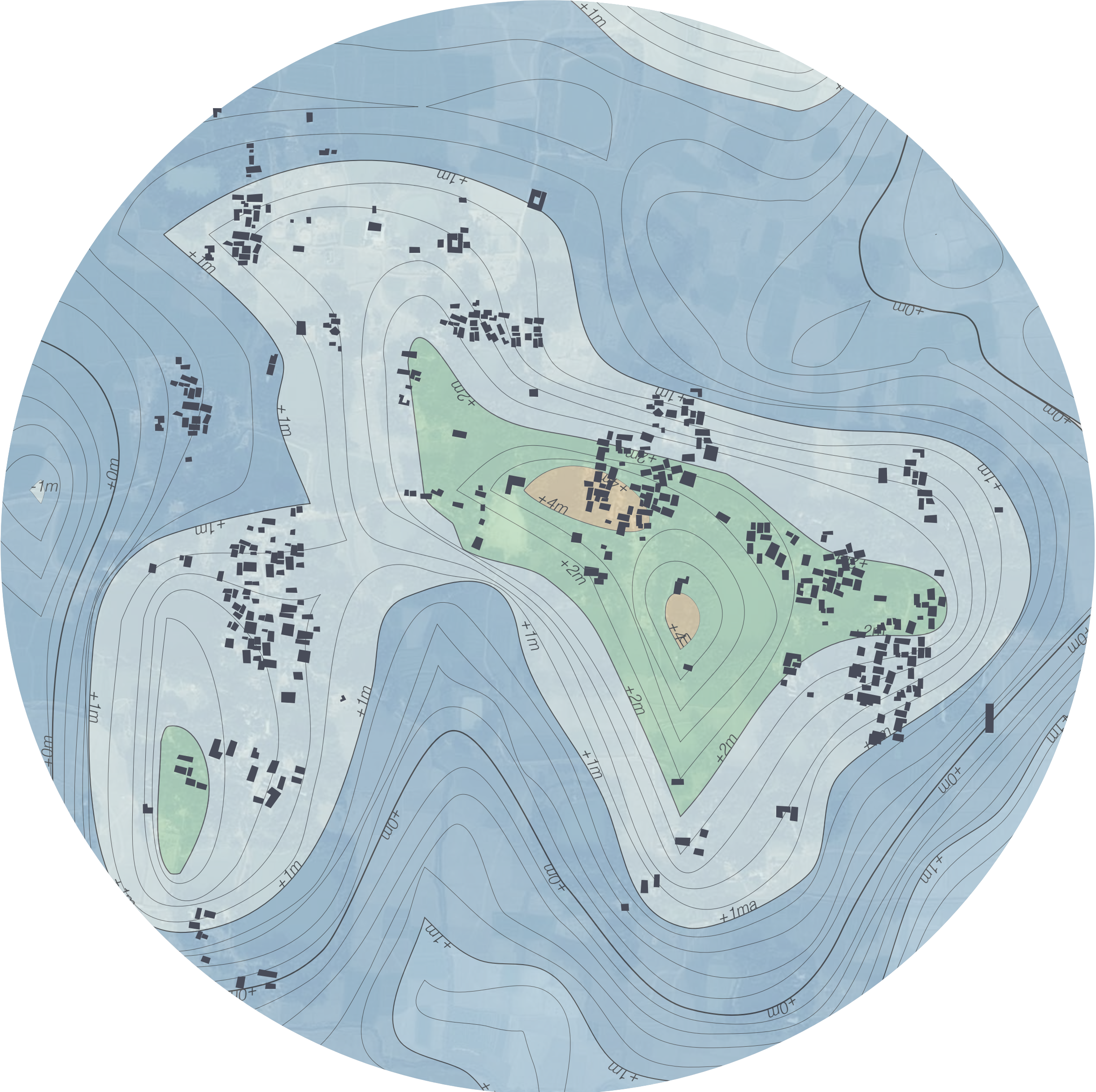

OUT OF REACH OF FLOOD

EXAMPLE SITE

Analysis

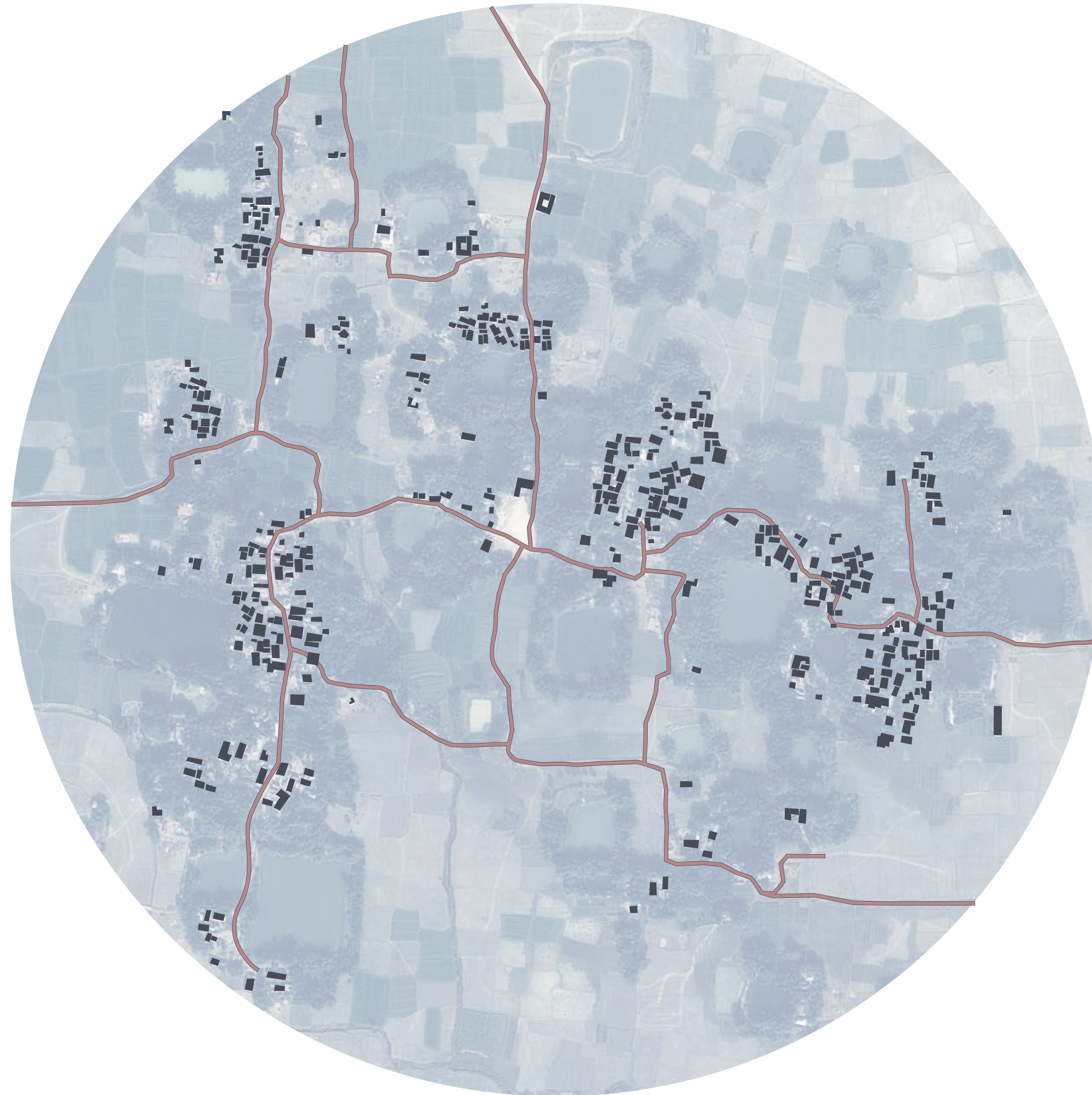

INFRASTRUCTURE

EXAMPLE SITE

Analysis



CENTRAL SQUARE

EXAMPLE SITE

Analysis



LOCATION

DESIGN MOTIVES

SITE
Location

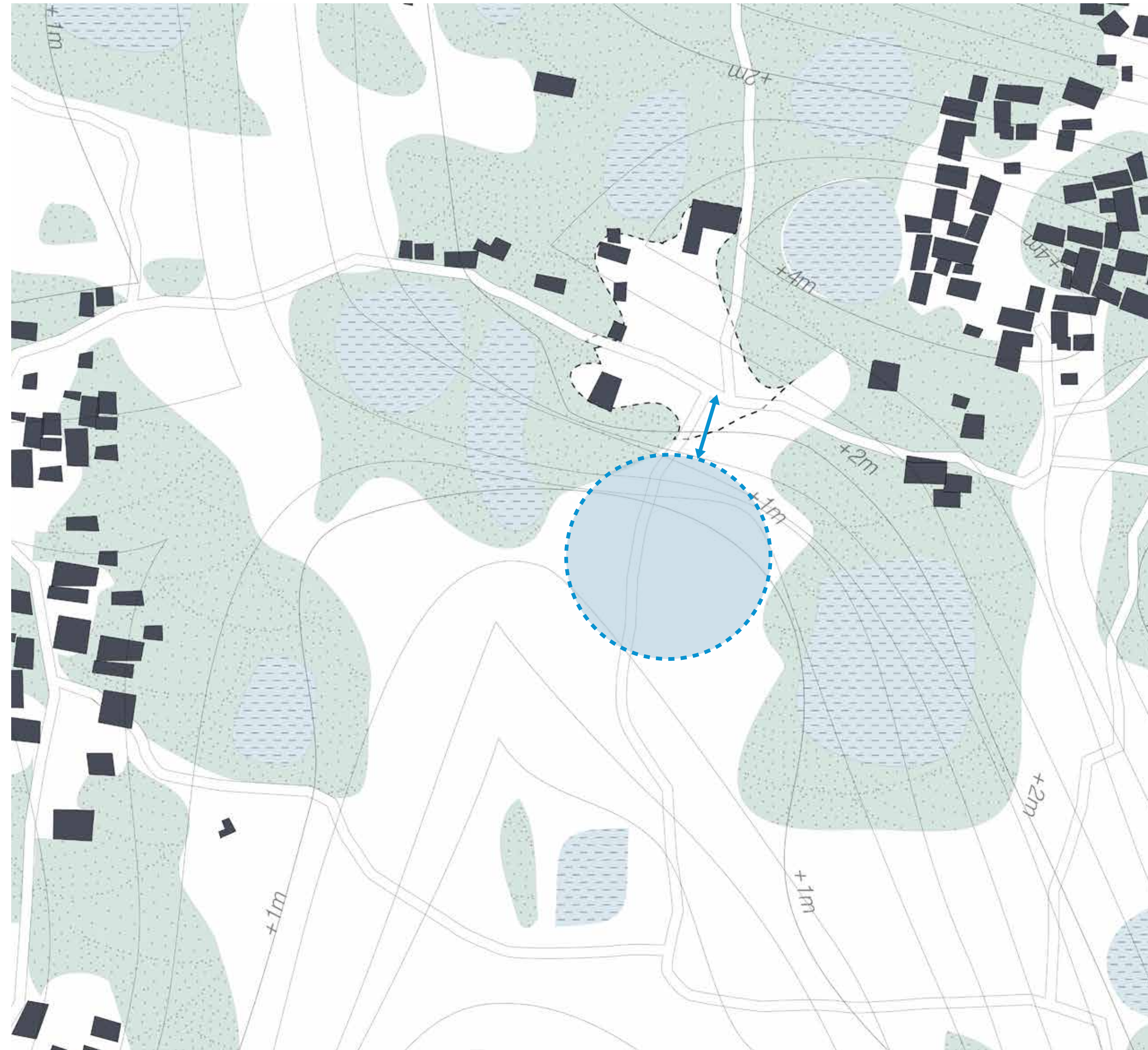

CONNECTION WITH MAIN SQUARE

SITE
Boundary



BOUNDARY OF BUILDABLE AREA

SITE
Configuration

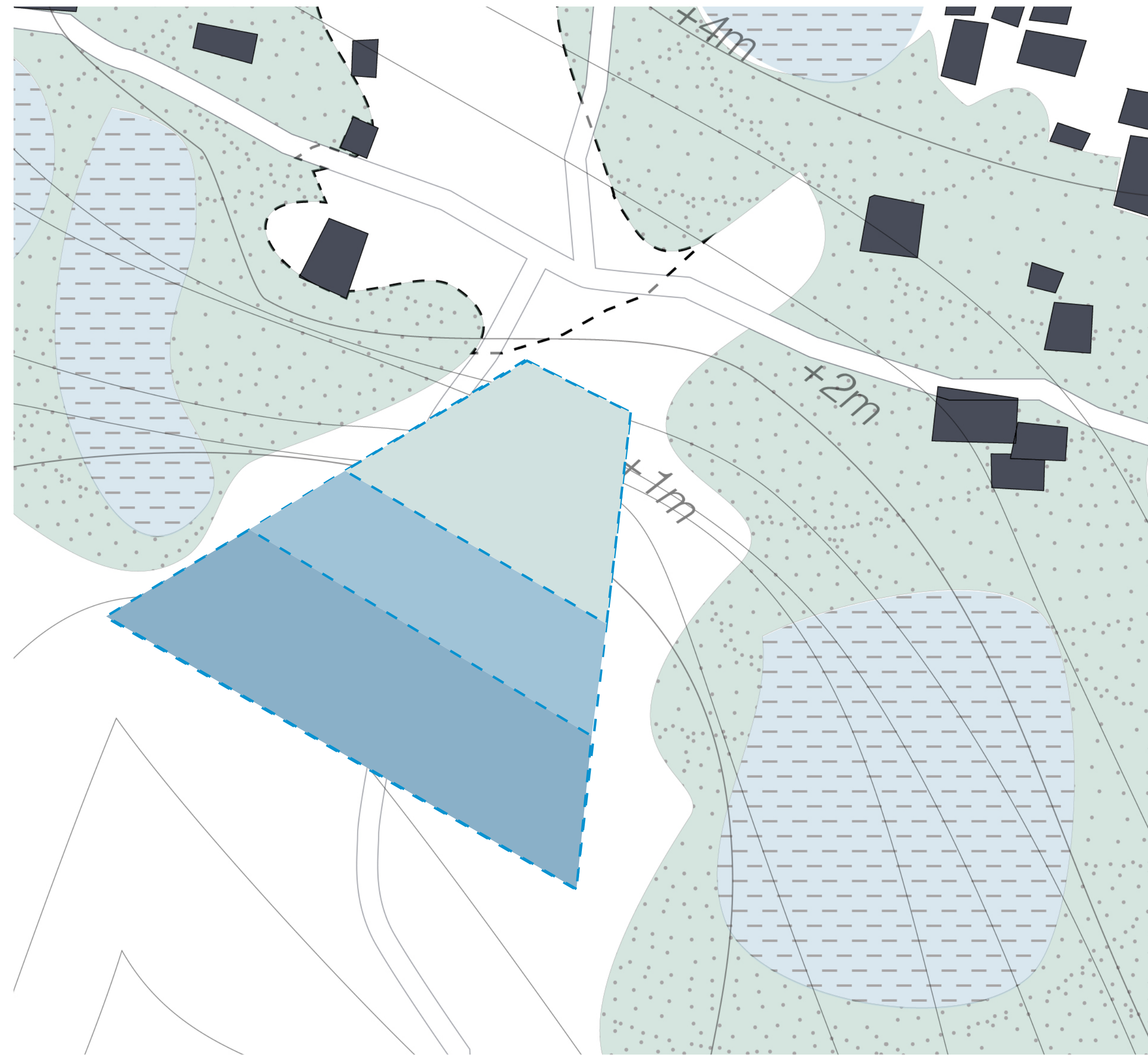

PUBLIC TO PRIVATE

SITE
Concept Mass

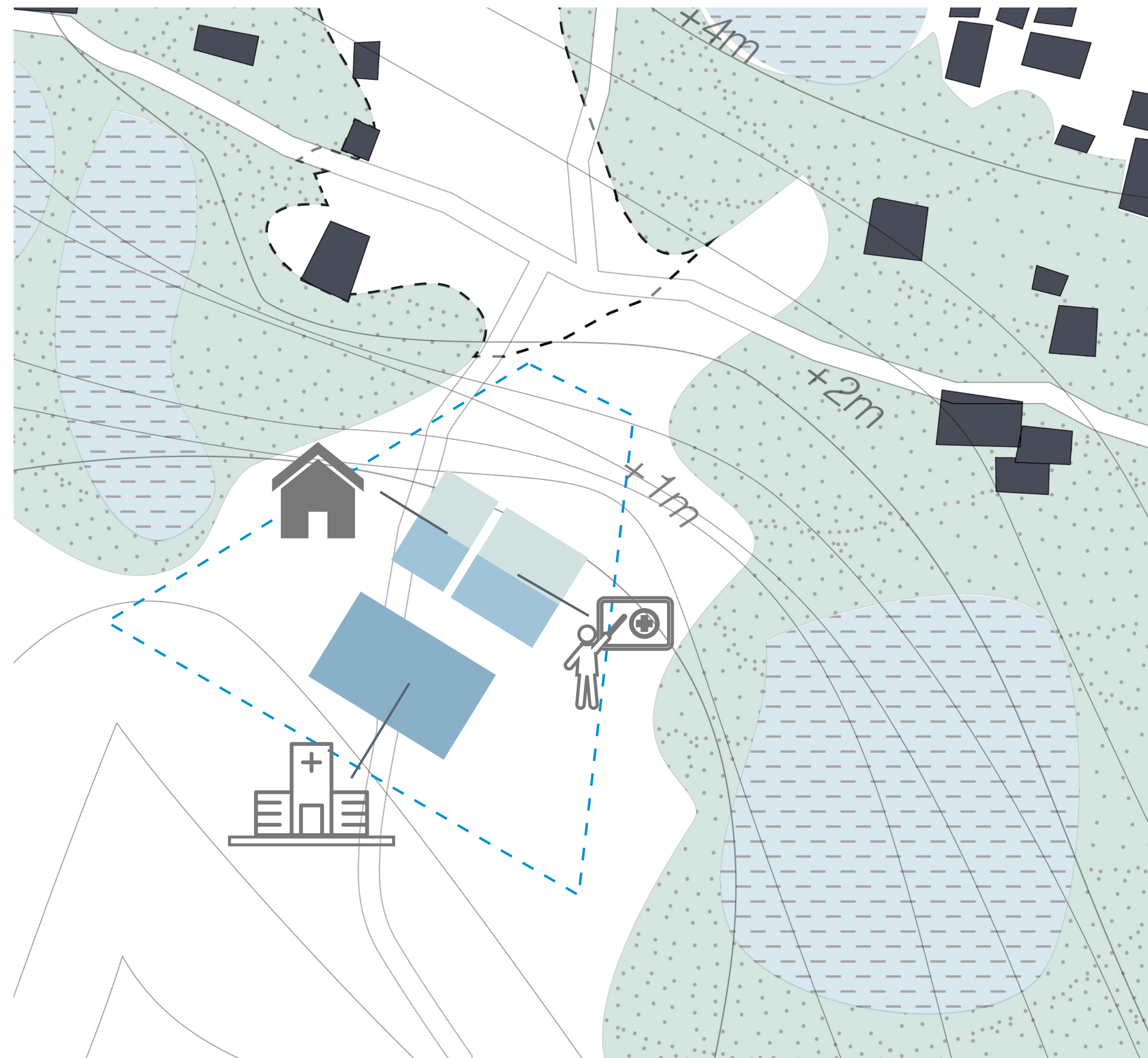

3 OBJECTS FOR THE 3 FUNCTIONS

SITE
Concept Mass

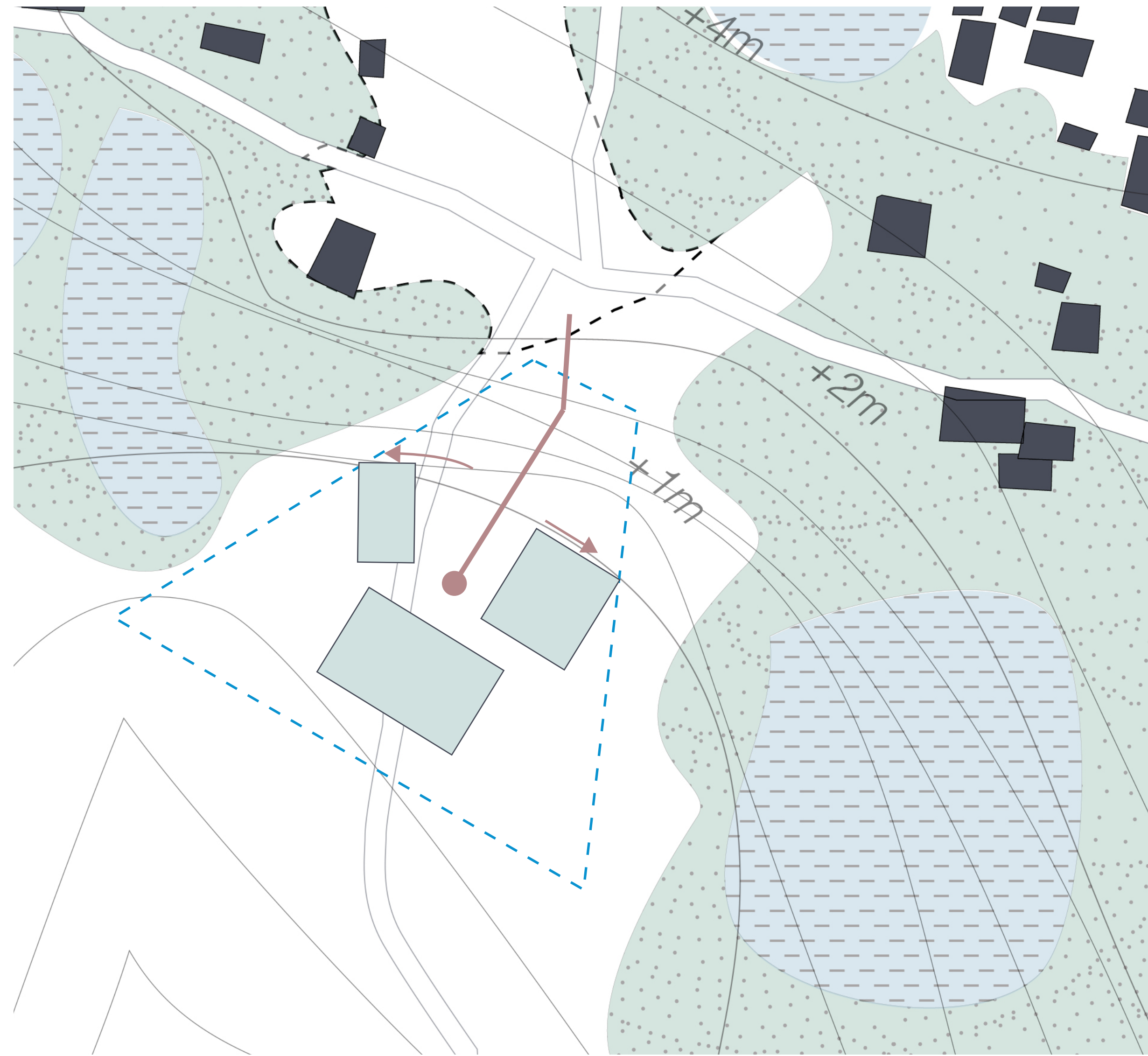

OPENING MASS TO THE SQUARE

SITE
Concept Mass



CREATING OPENING FOR AIR FLOW

SITE
Concept Mass



CONNECTION BETWEEN THE OBJECTS

SITE
Concept Mass

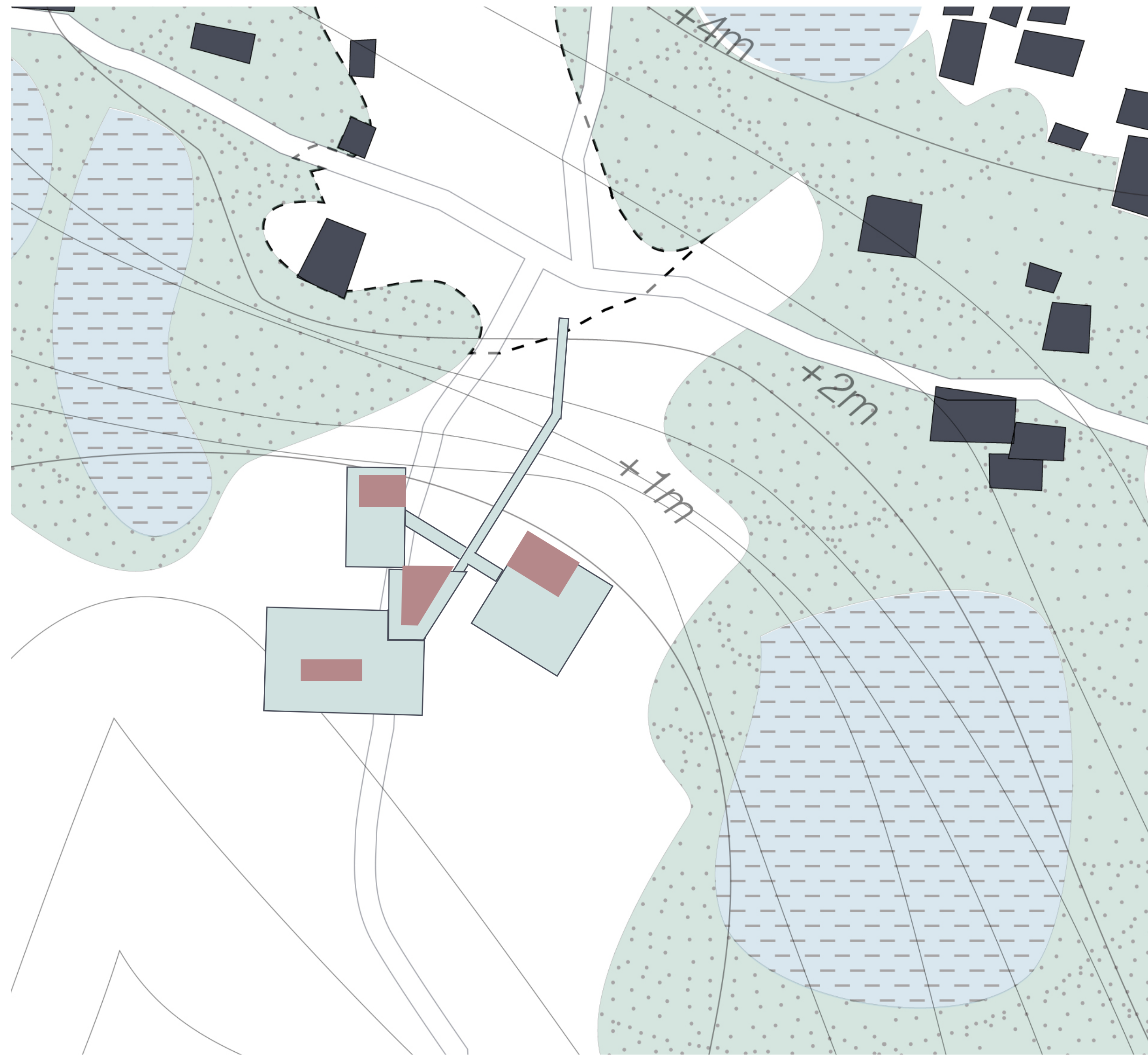

WATER COURTS

PROGRAM

Concepts

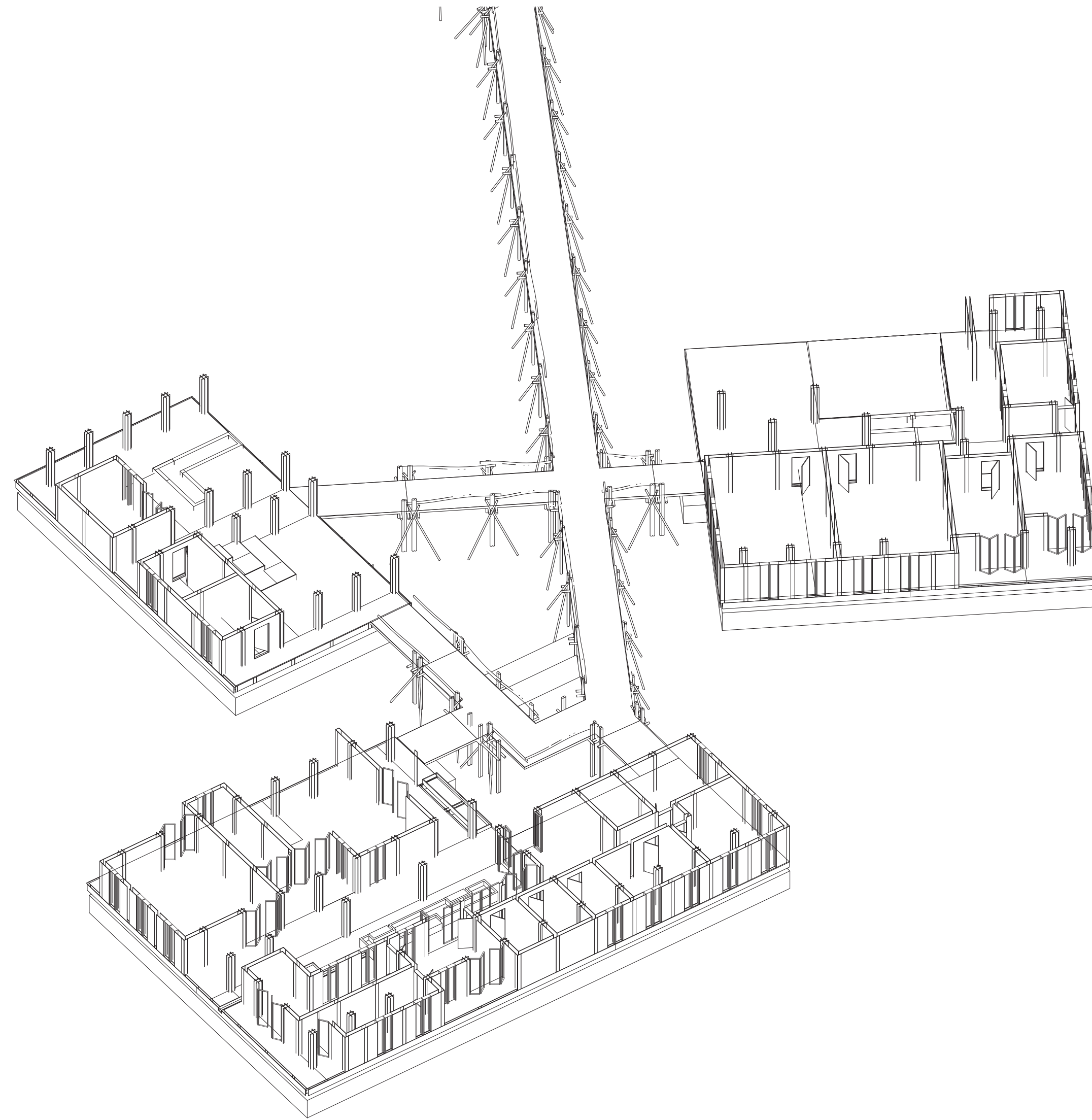

Axonometric view

PROGRAM

Concepts

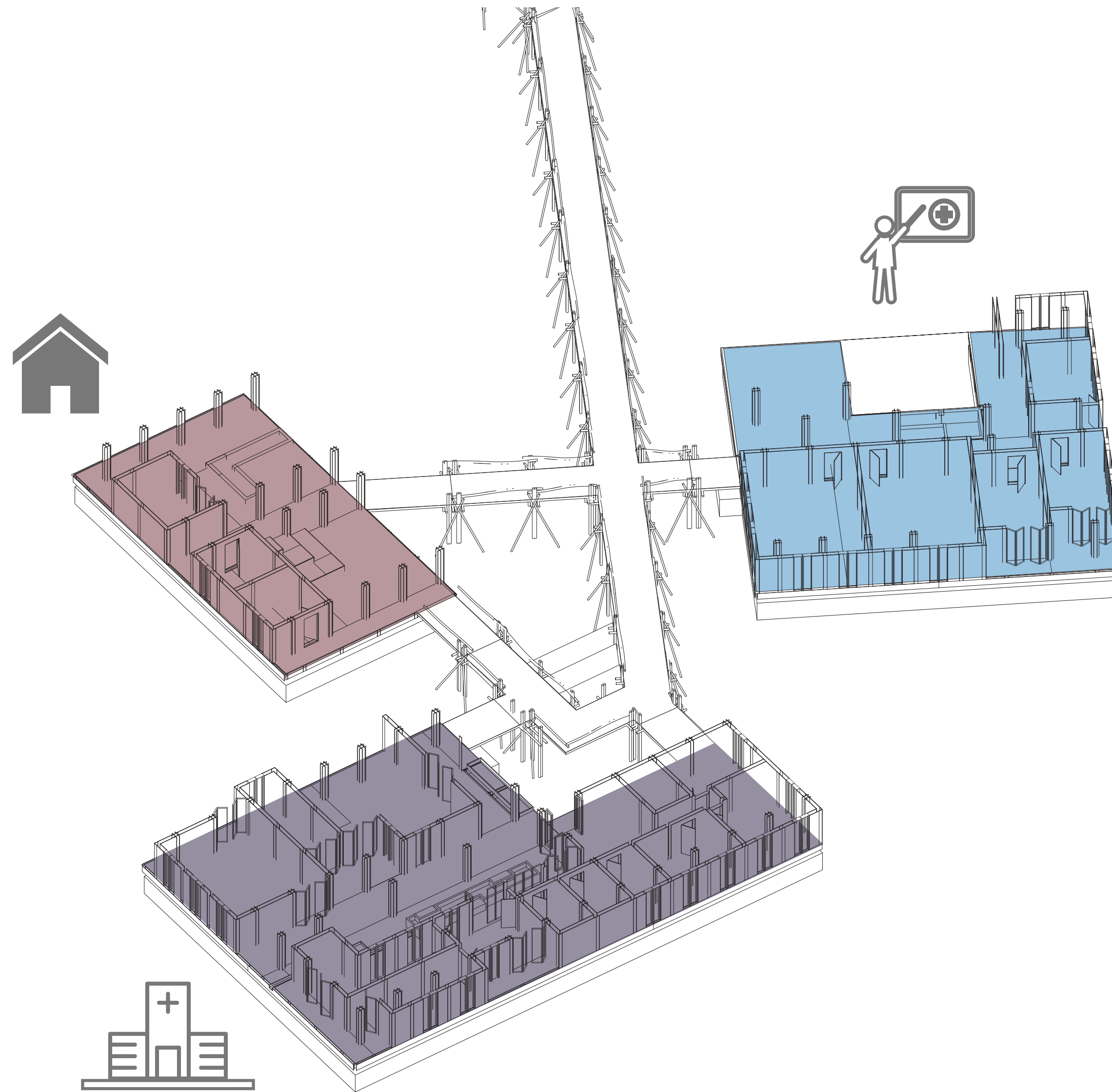

Main functions per building

PROGRAM

Concepts

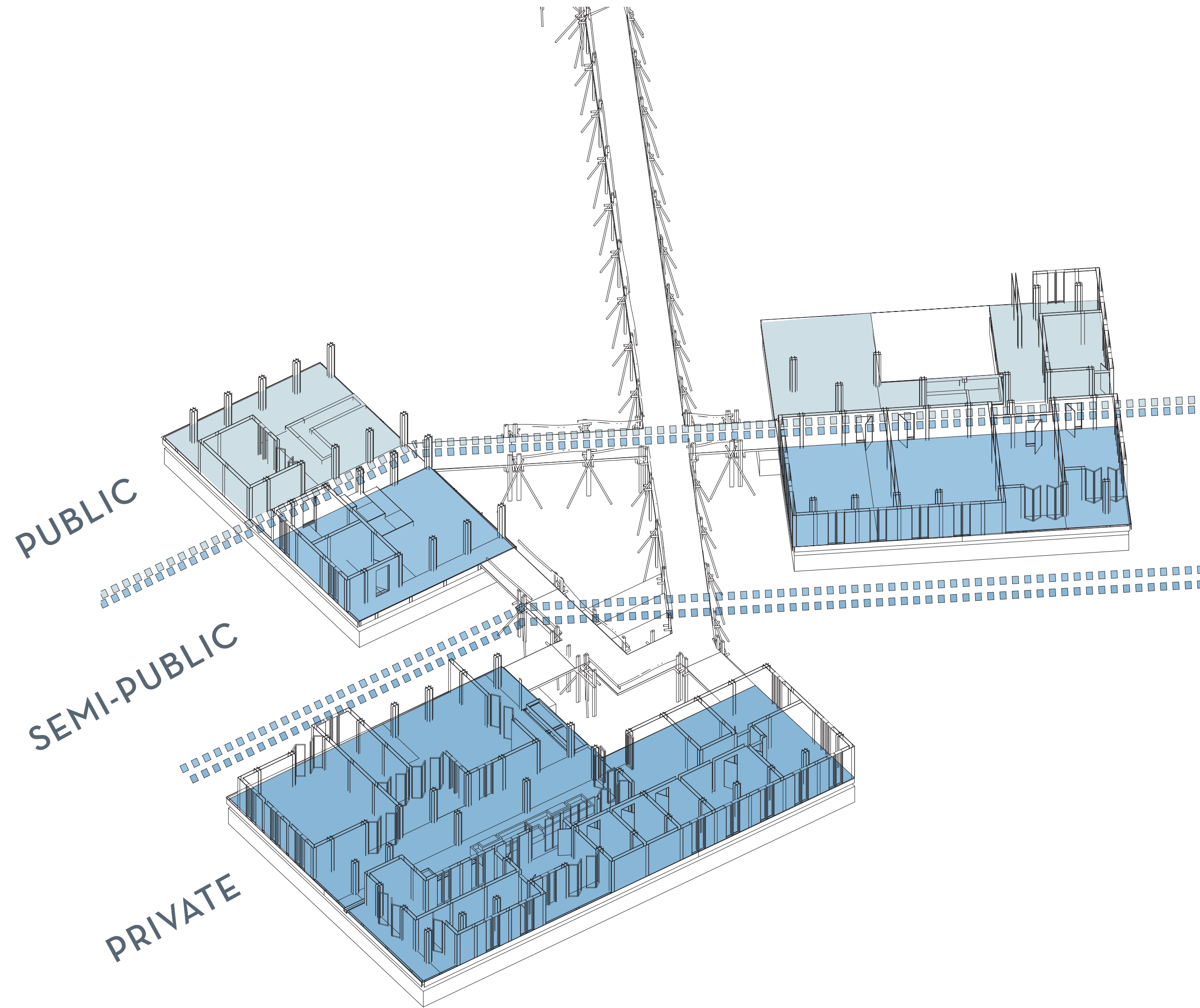

Organization spaces from public to private

PROGRAM

Concepts

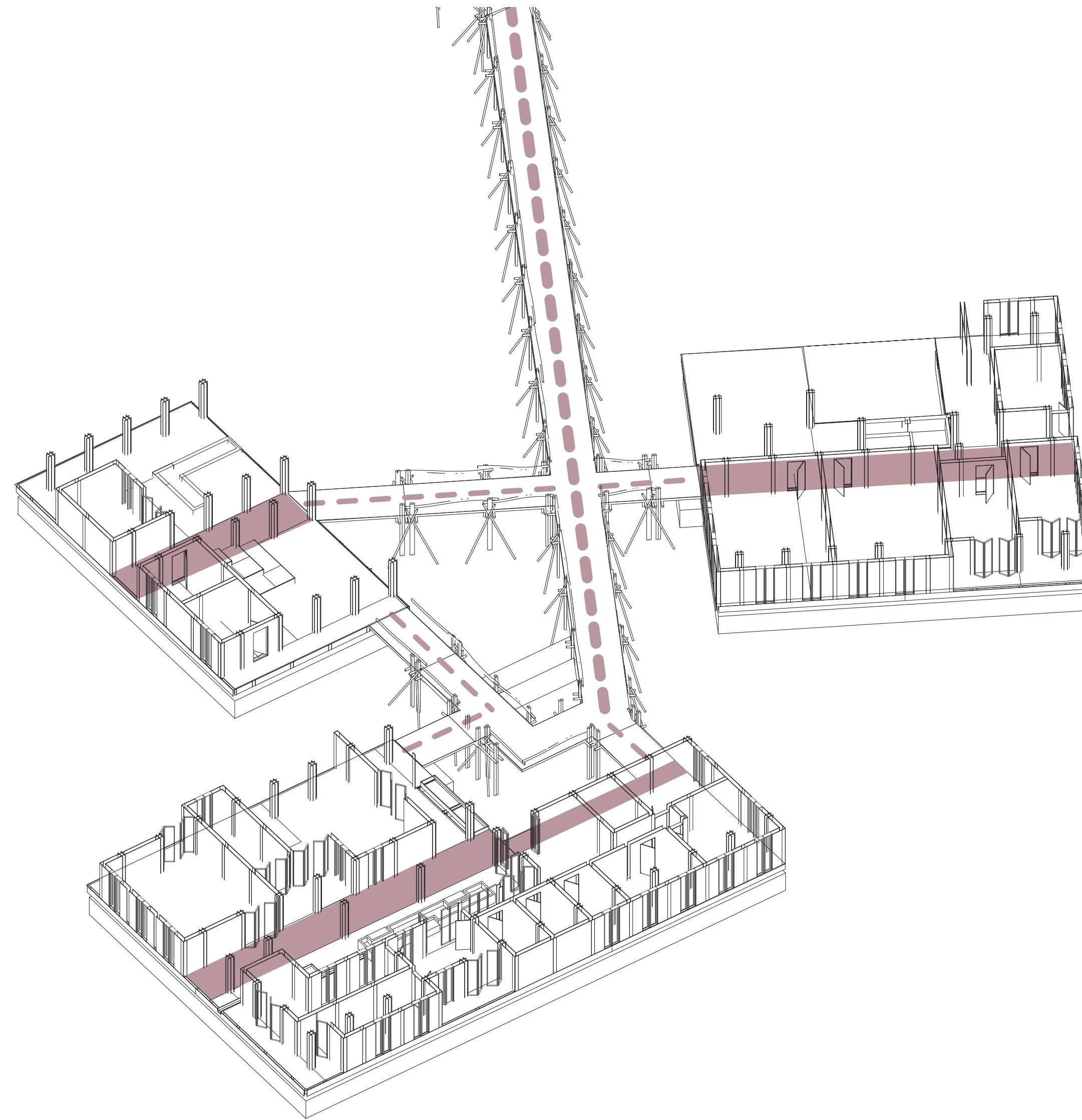

Central corridors interlinking
buildings and spaces within

PROGRAM

Concepts

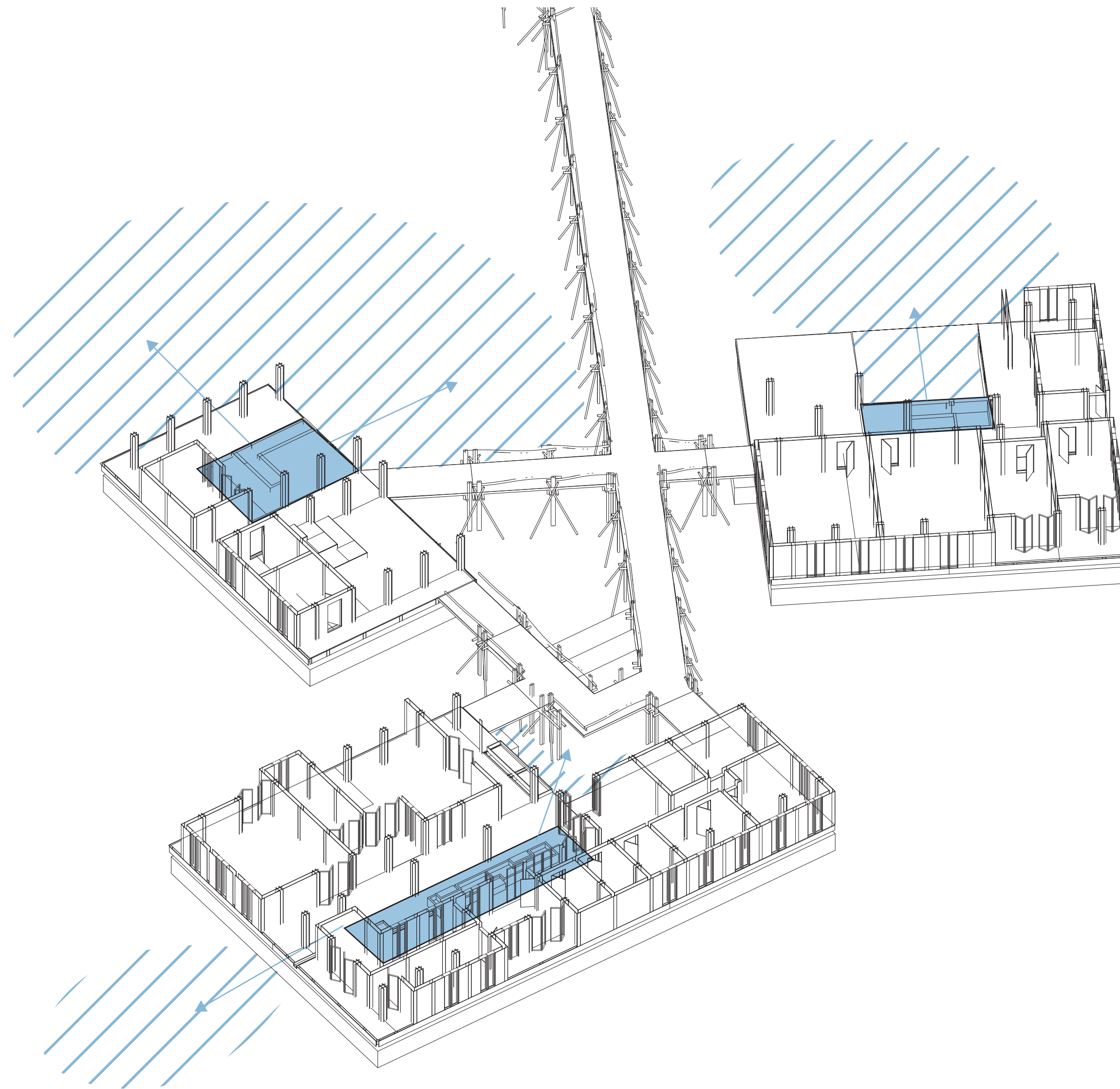

Watercourts contrasting clean water
with floodwater

FLOORPLAN

Total

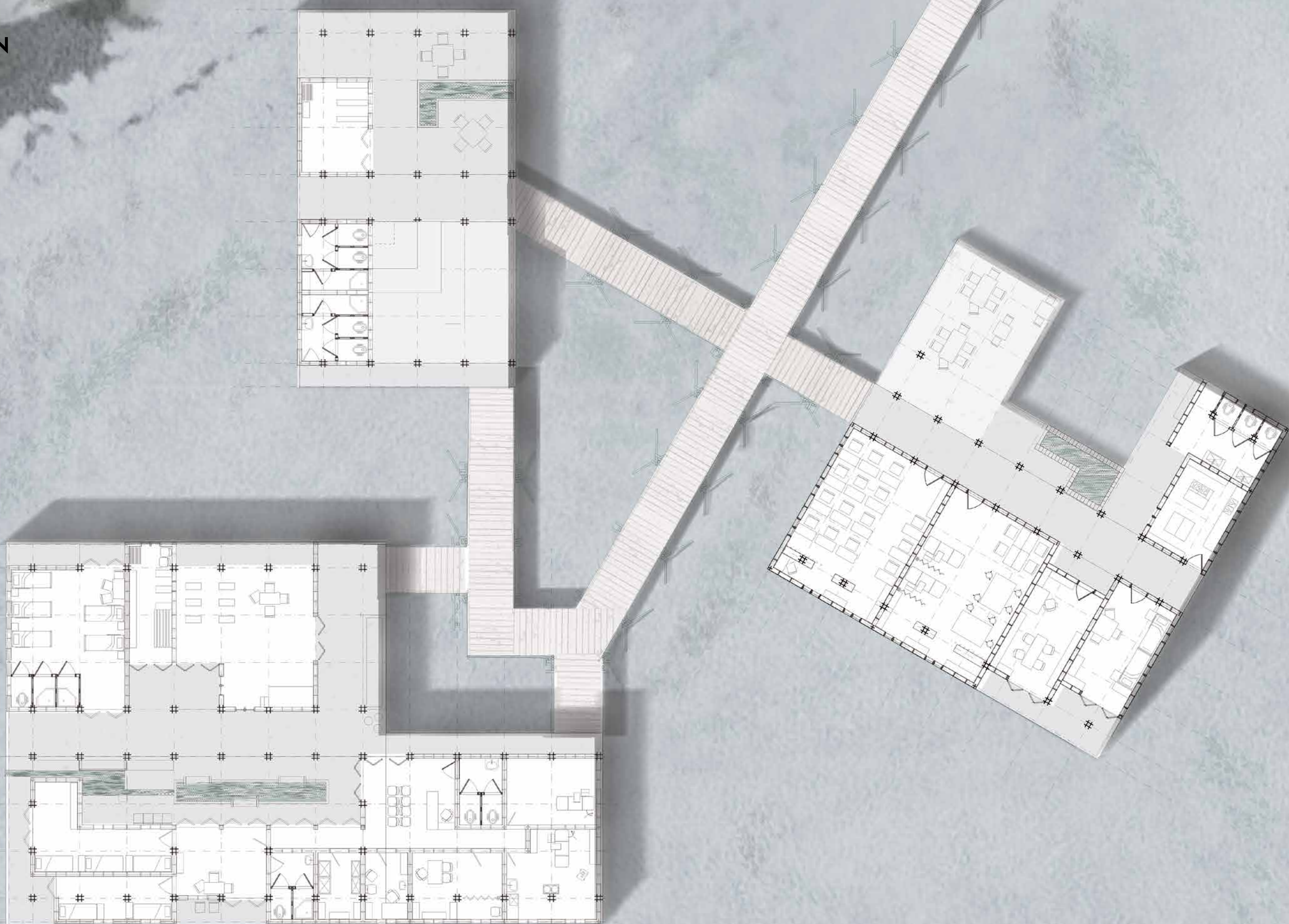

FLOOR PLAN

Clinic

Overnight stay

Storage

Extra over-night stay /
Emergency

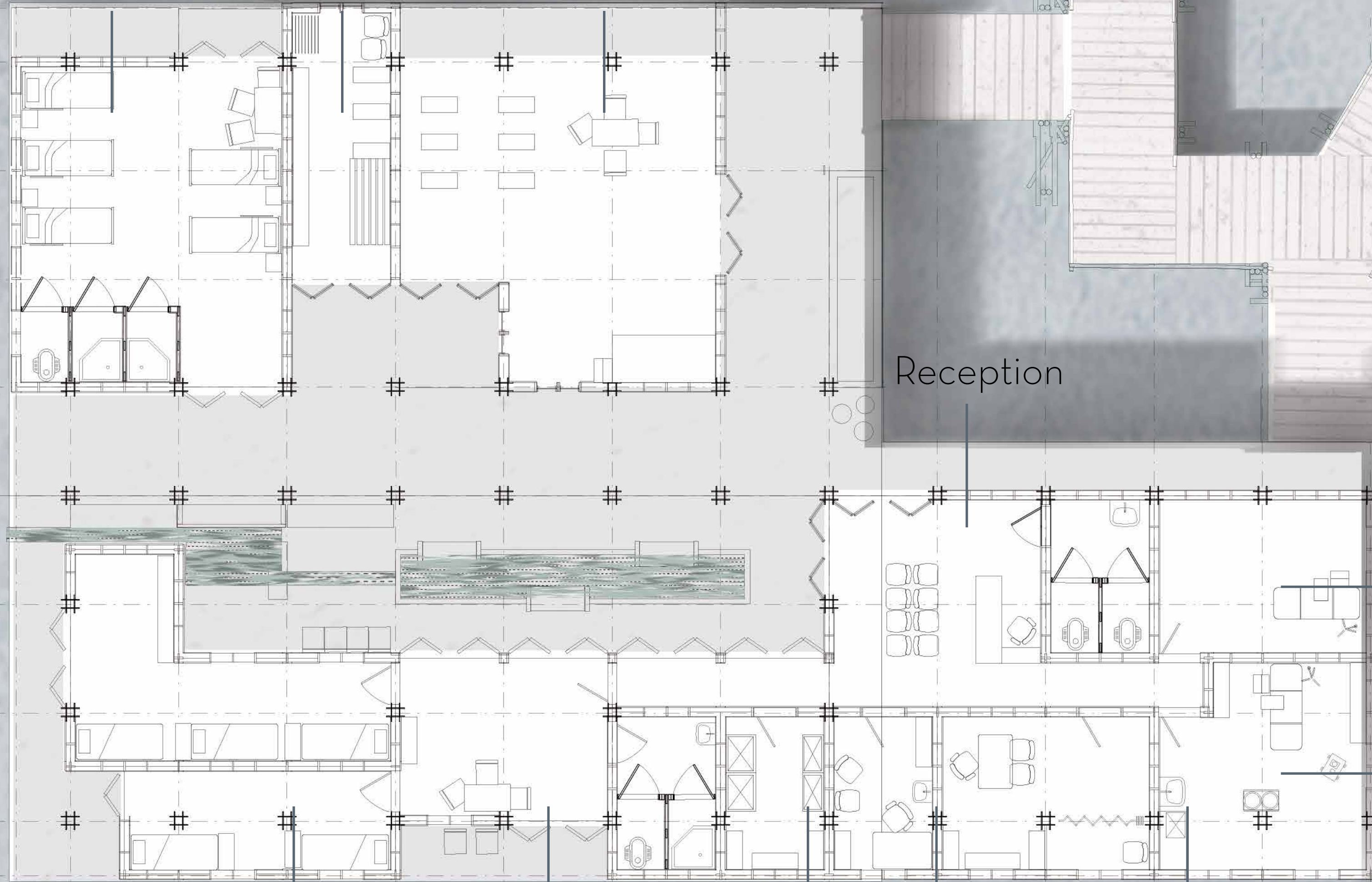

Reception

Examina-
tion
room

Treatment

Staff
Bedrooms

Staff break
room

Storage
Medical
Assistants

Office /
Examina-
tion

FLOOR PLAN

Community

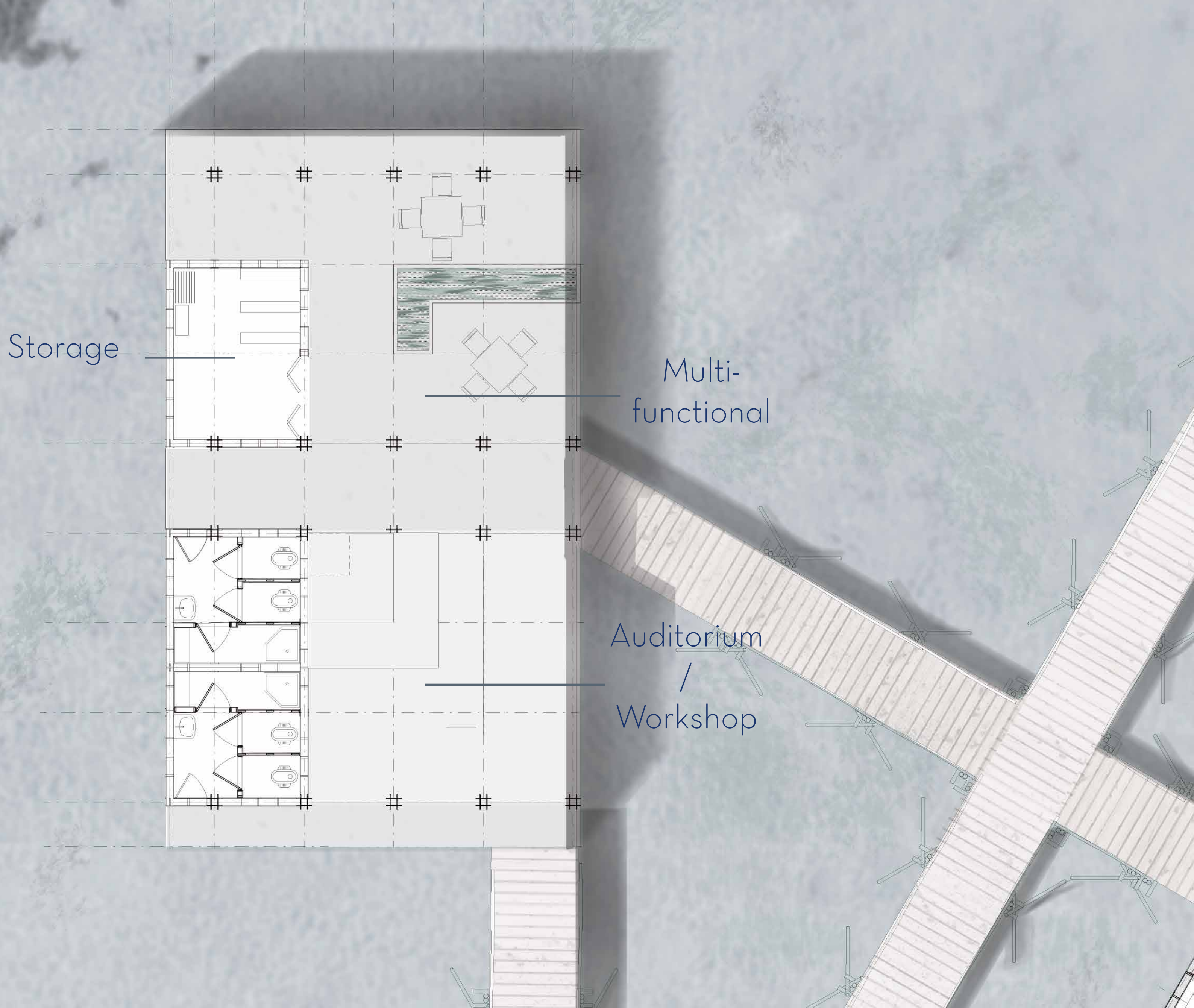

Storage

Multi-functional

Auditorium / Workshop

FLOOR PLAN

Education

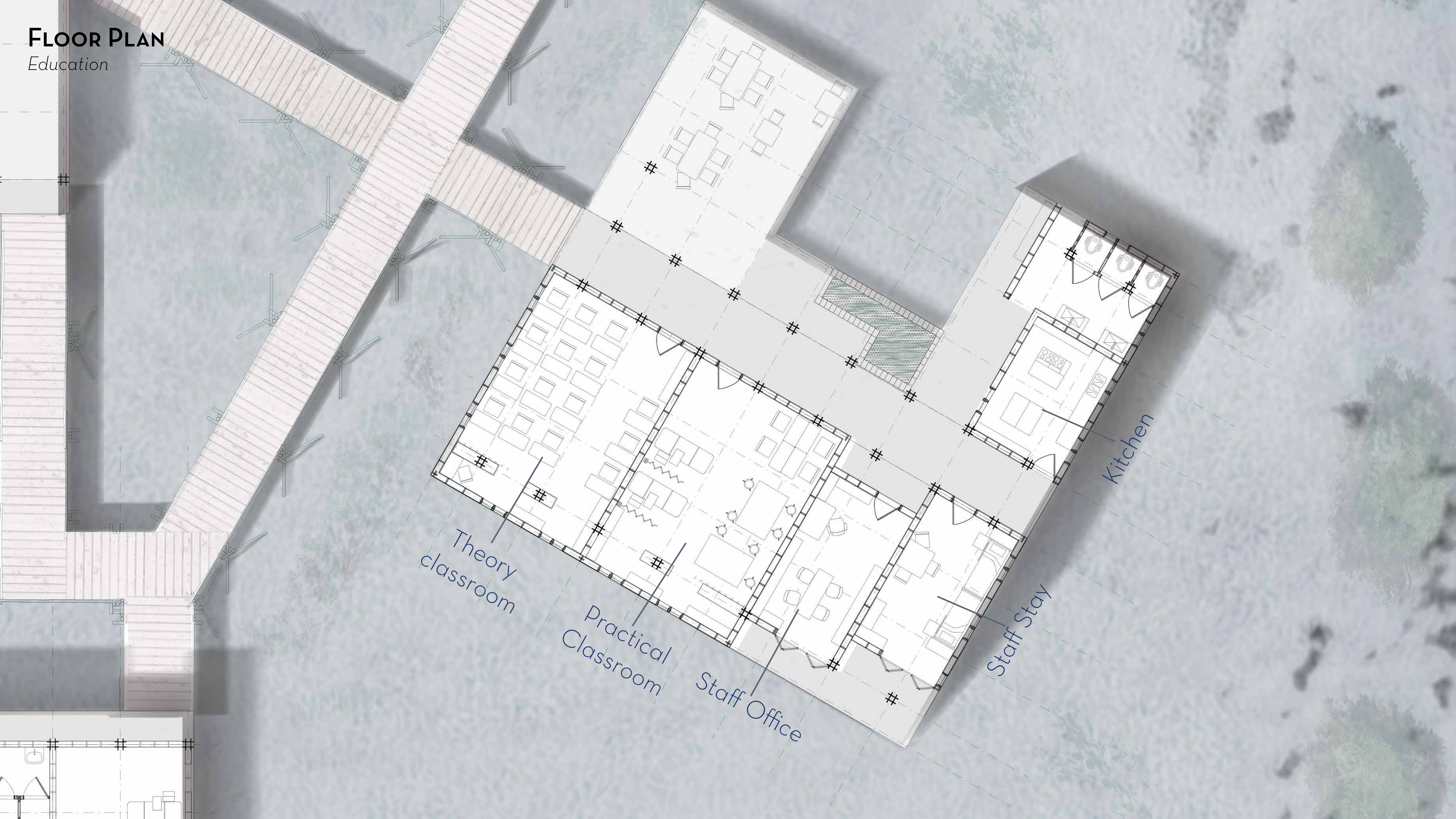

Theory
classroom

Practical
Classroom

Staff Office

Staff Stay

Kitchen

ROOF

DESIGN

Roof



DESIGN

Roof



DESIGN

Facades

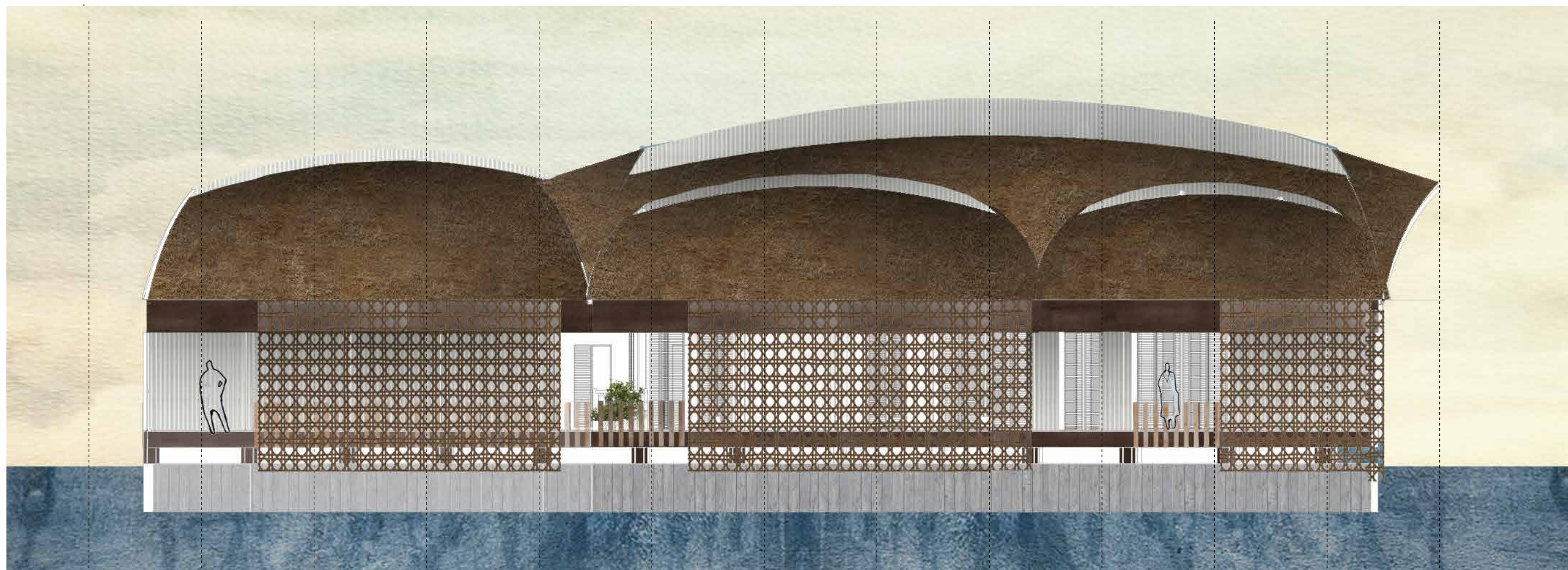

2400 2400 2400 2400 2400 2400 2400 2400 2400 2400 2400 2400 1200

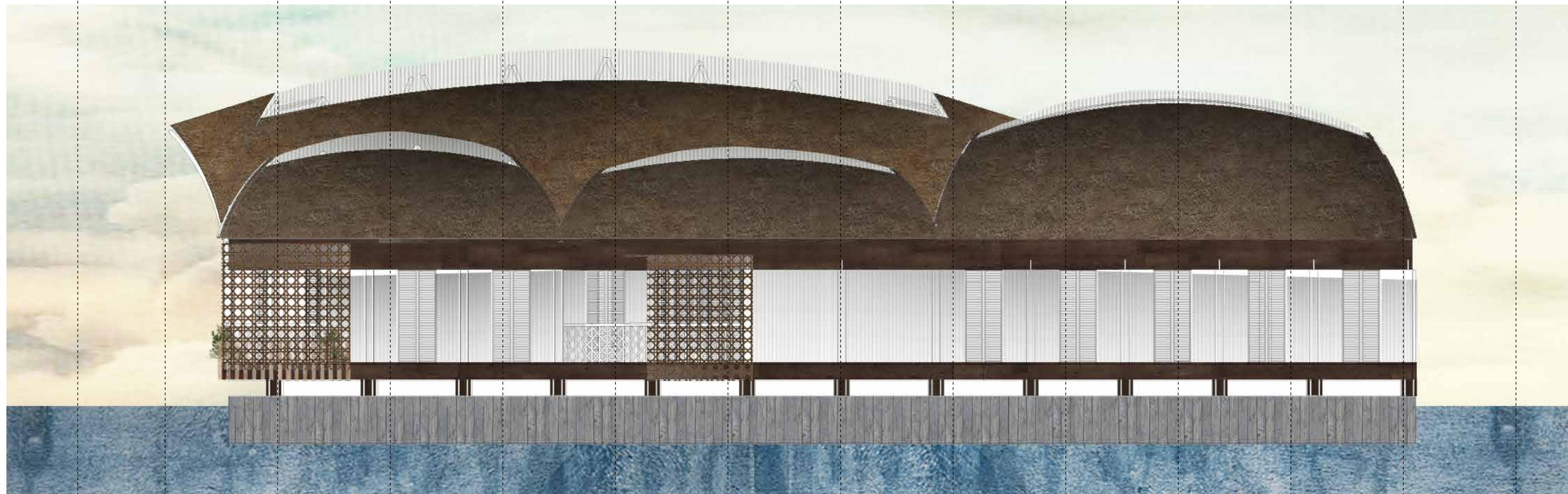

1200 2400 2400 2400 2400 2400 2400 2400 2400 2400 2400 2400

DESIGN

Section

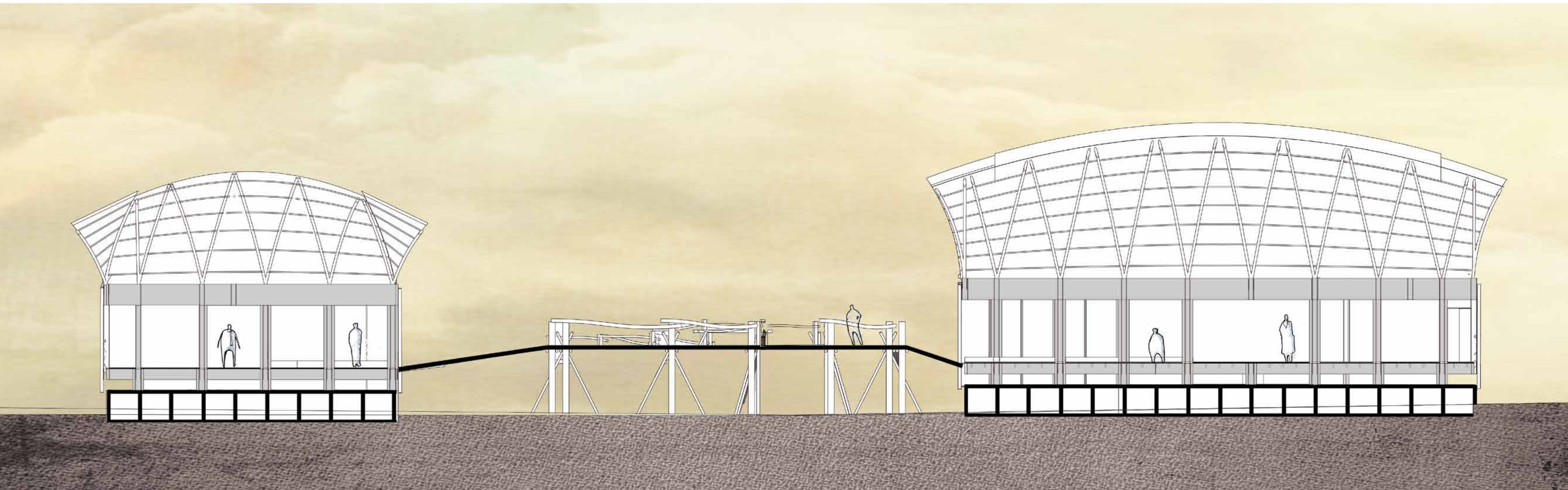

BUILDING SYSTEM

Roof detail 1:5

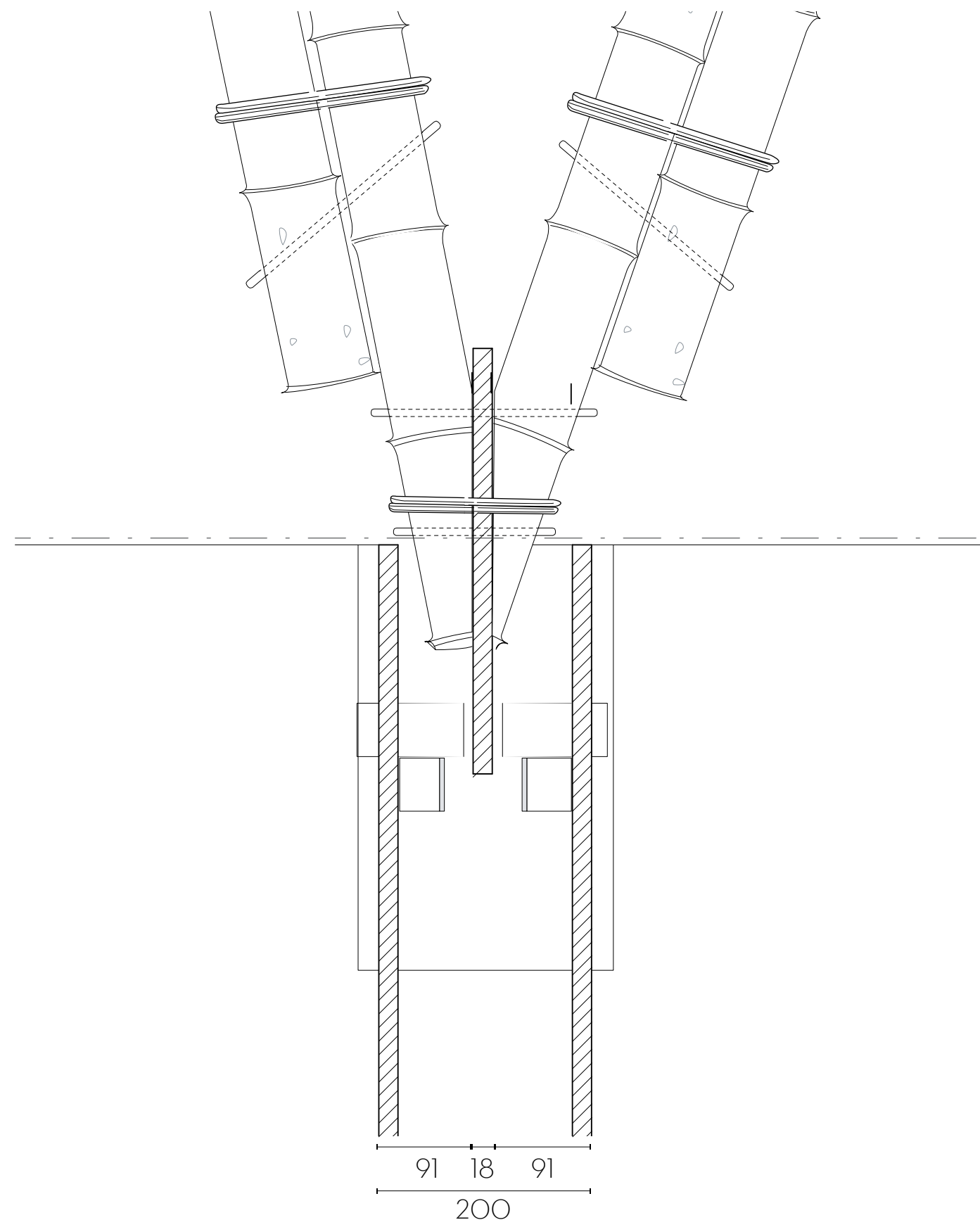

*one plate to connect two
roofbeams*

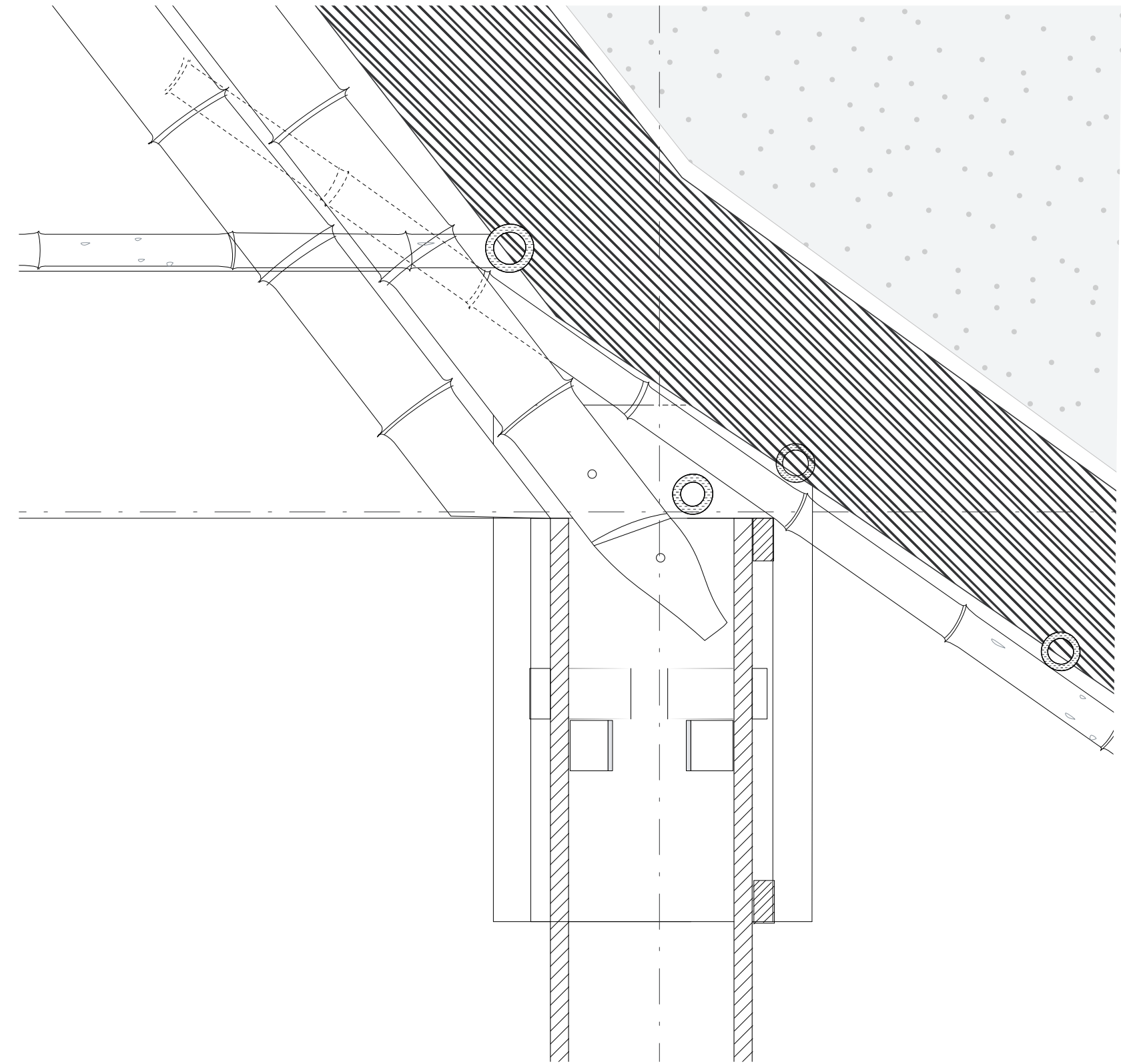

*Extra bamboo supports the
outer roof edge*

CLIMATE

Conditions in West Bengal

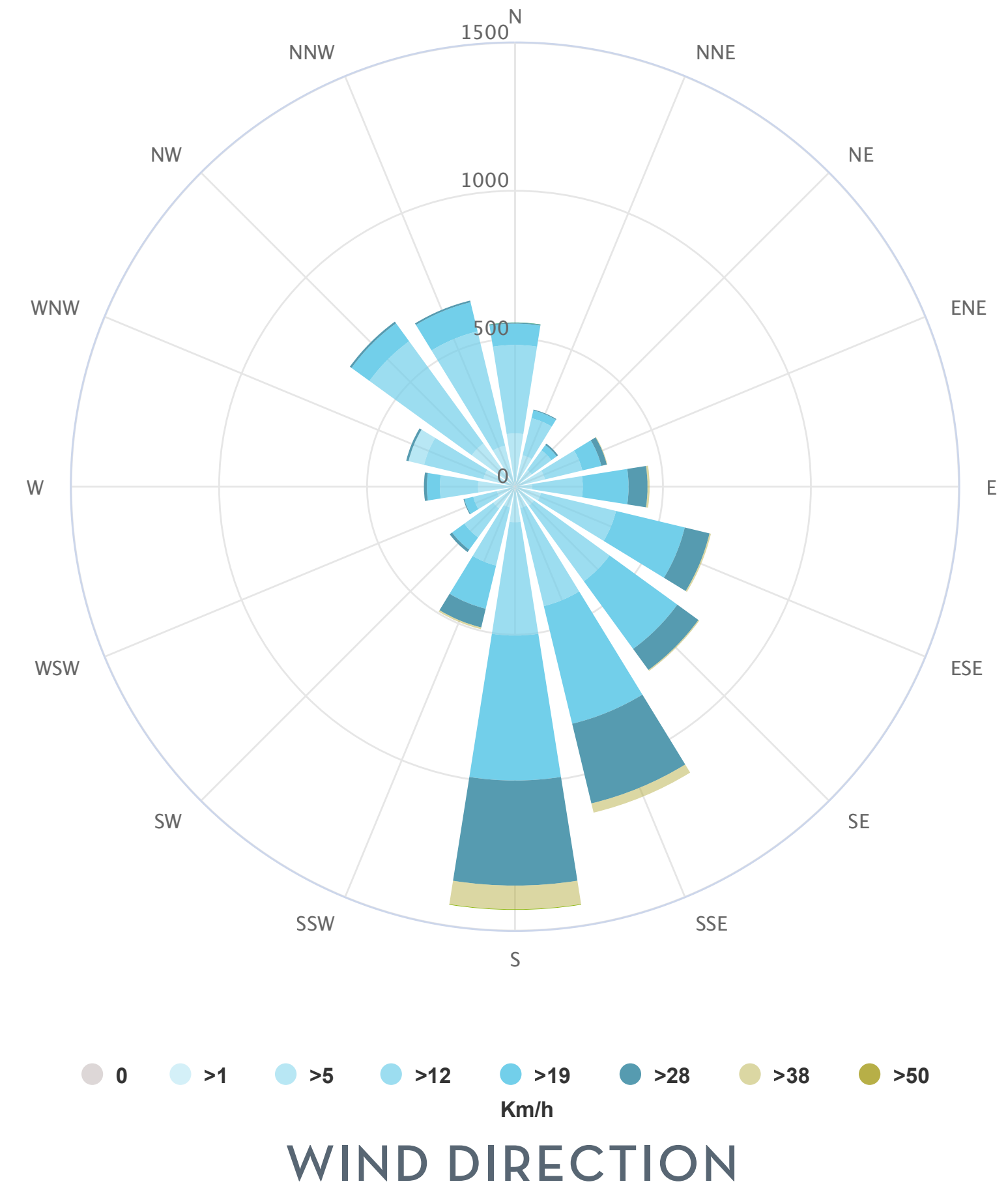
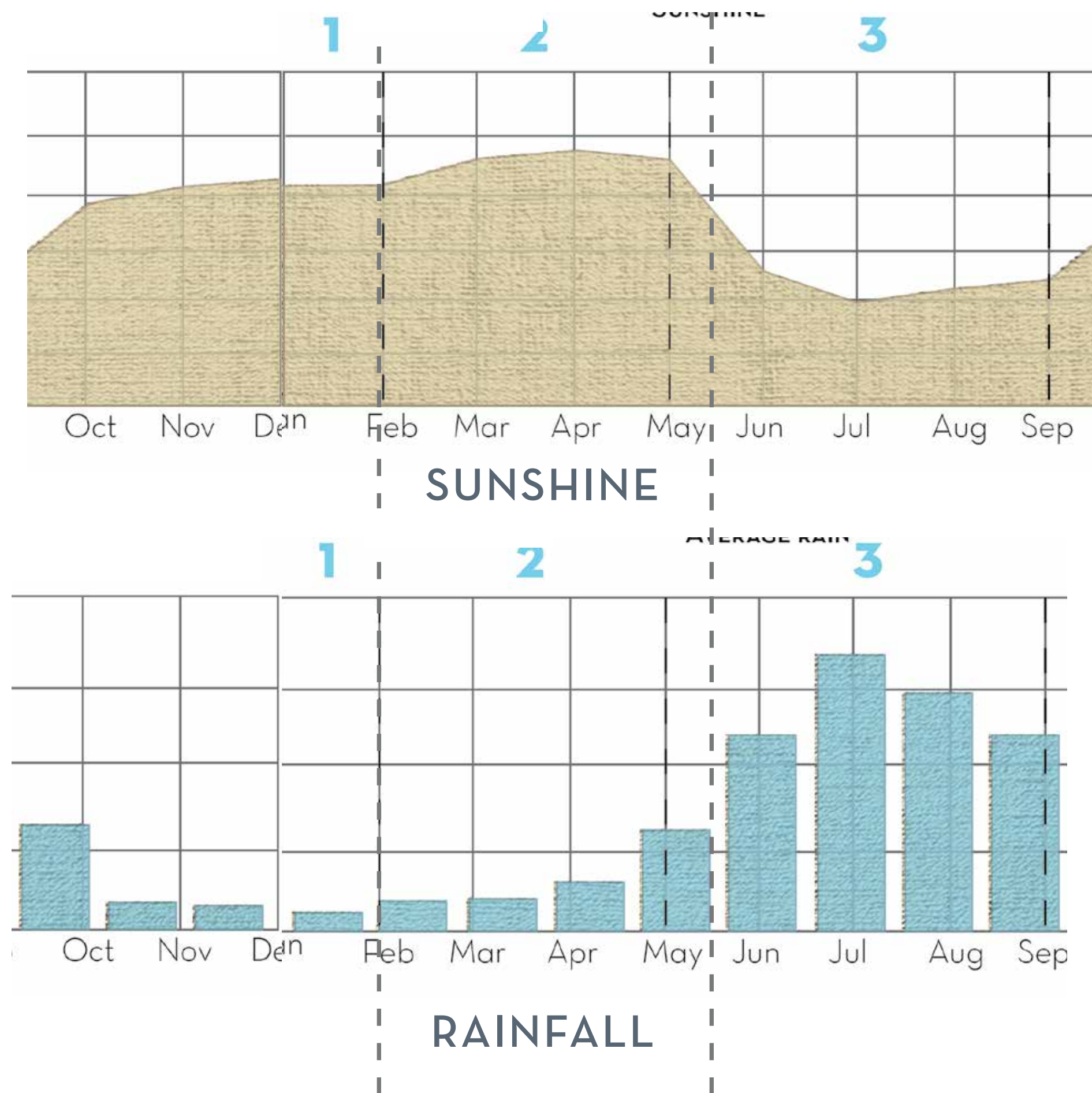

CLIMATE

Ventilation with wind

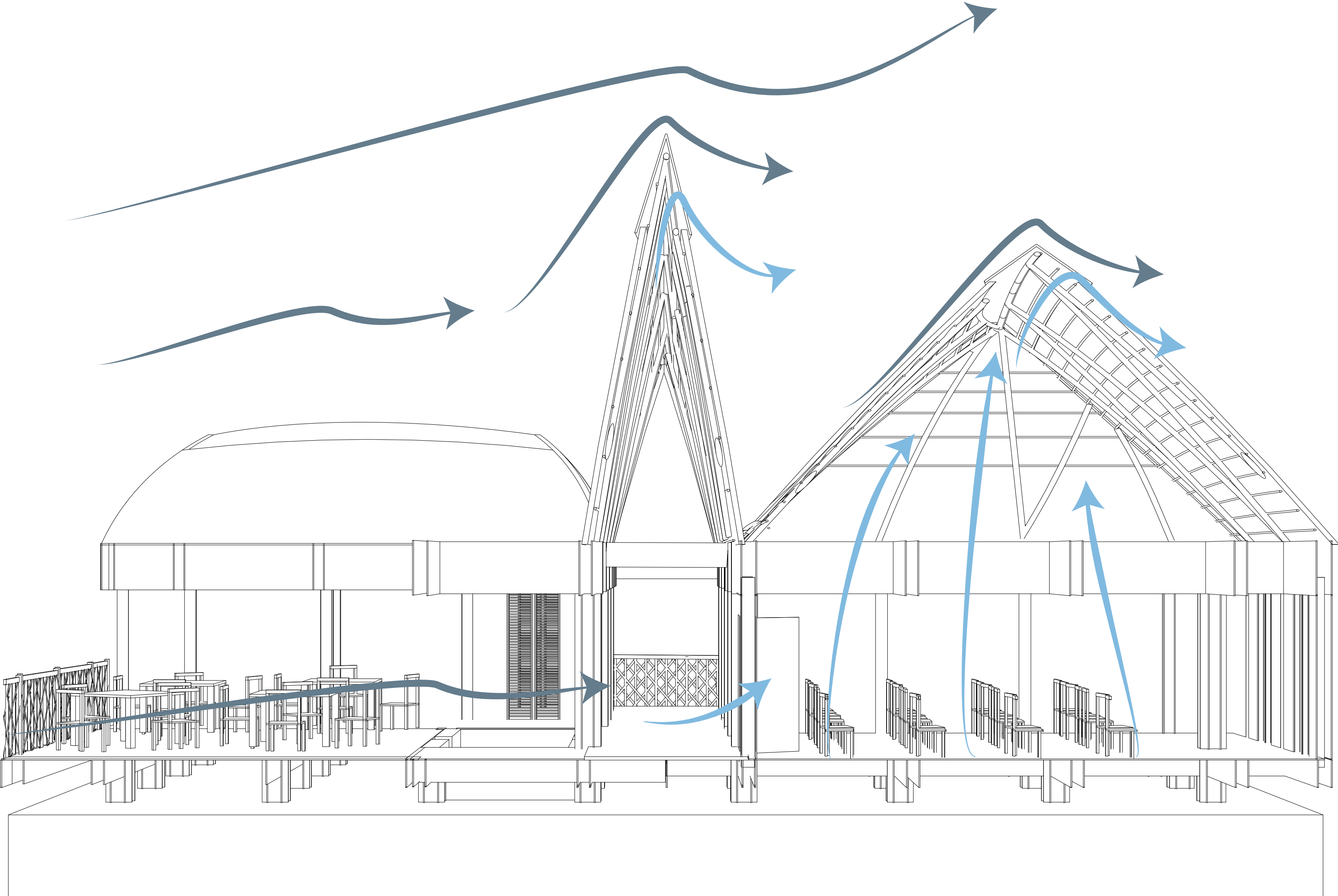

CLIMATE

Ventilation without wind

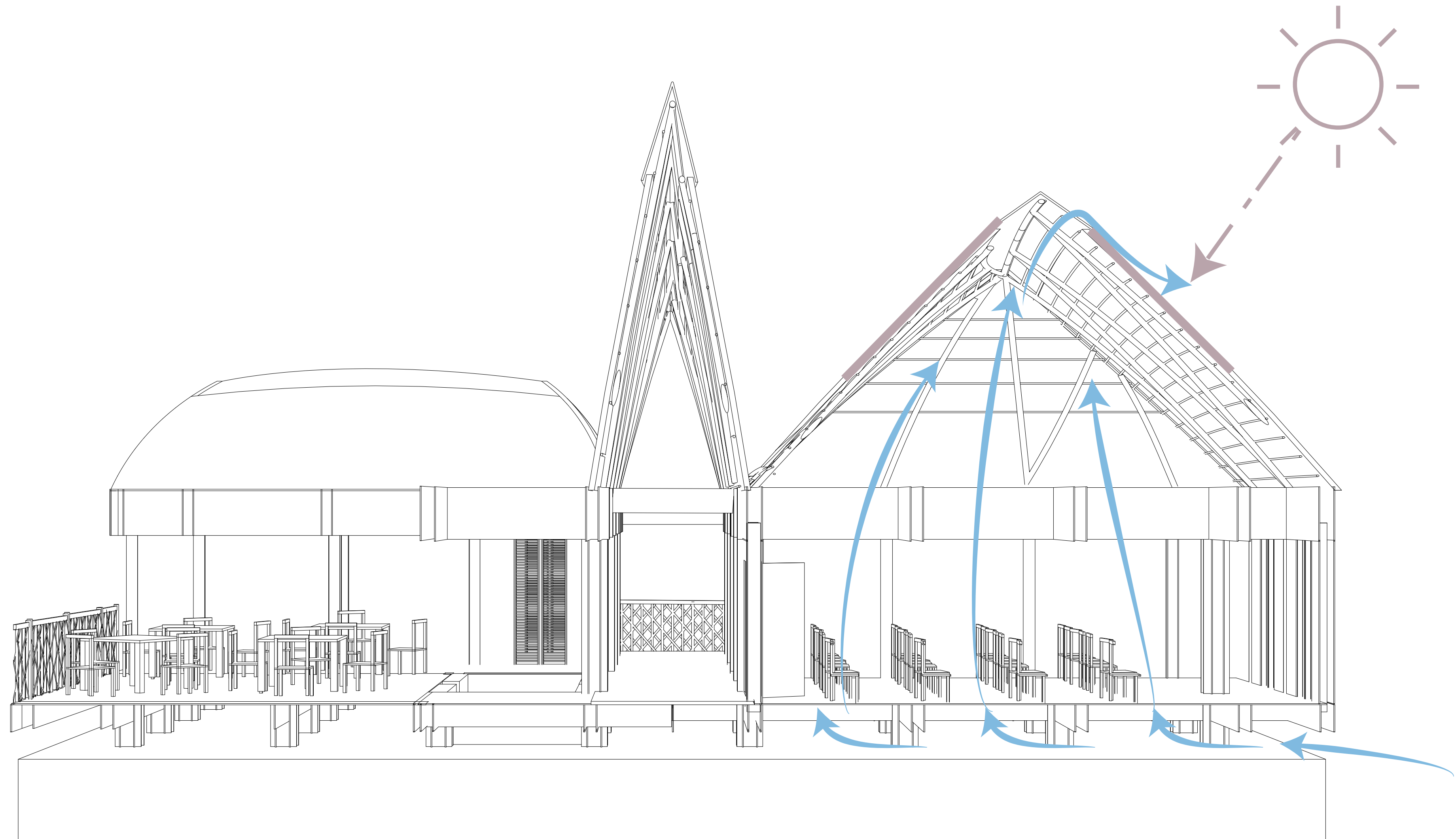

CLIMATE
1 - 20 section

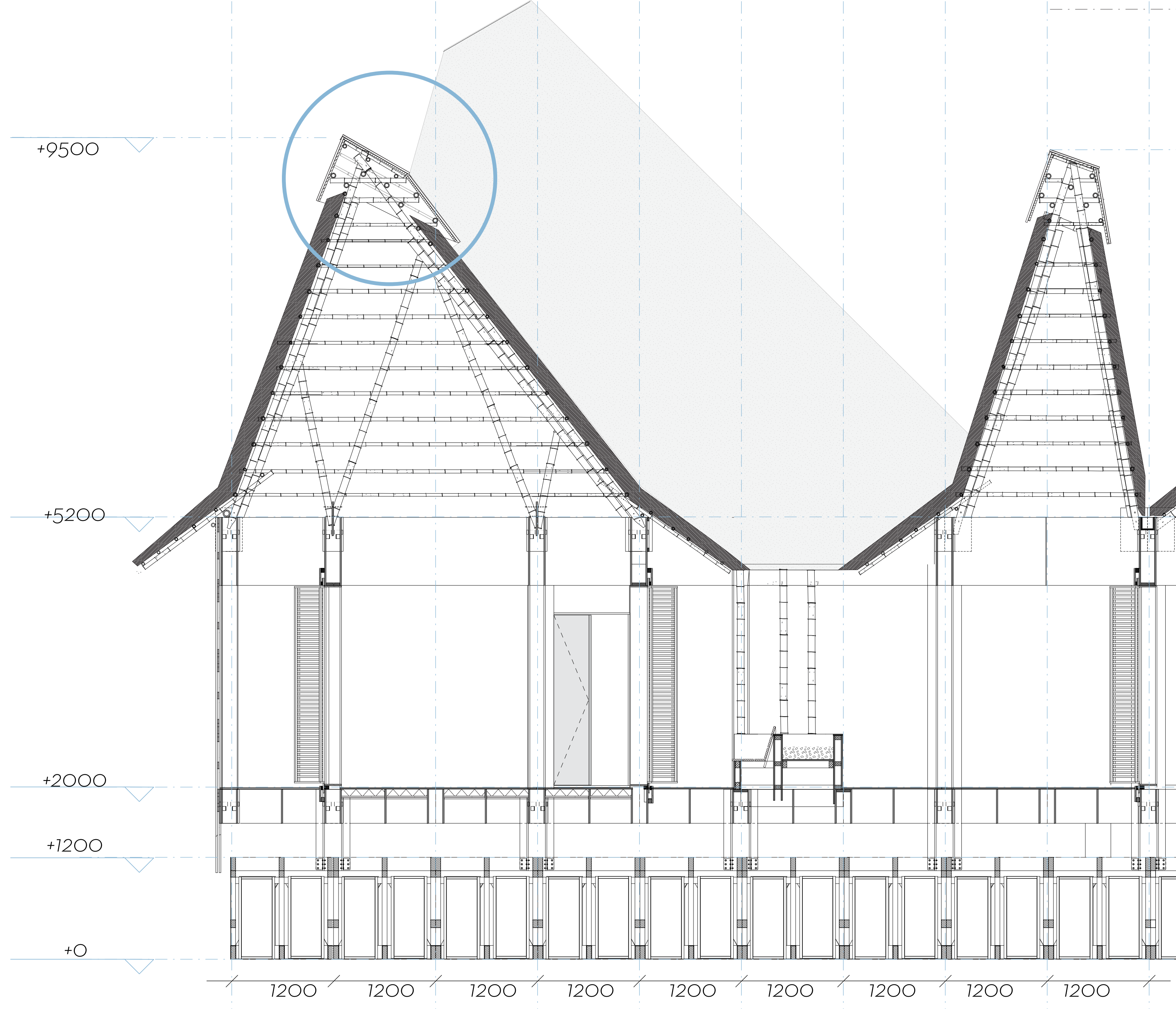

CLIMATE
Rooftop detail

Polycarbonate corrugated panel
Wooden batten 50 x 20 mm
Bamboo sub-structure

Zinc patch

Thatch roof tied off to bamboo substructure

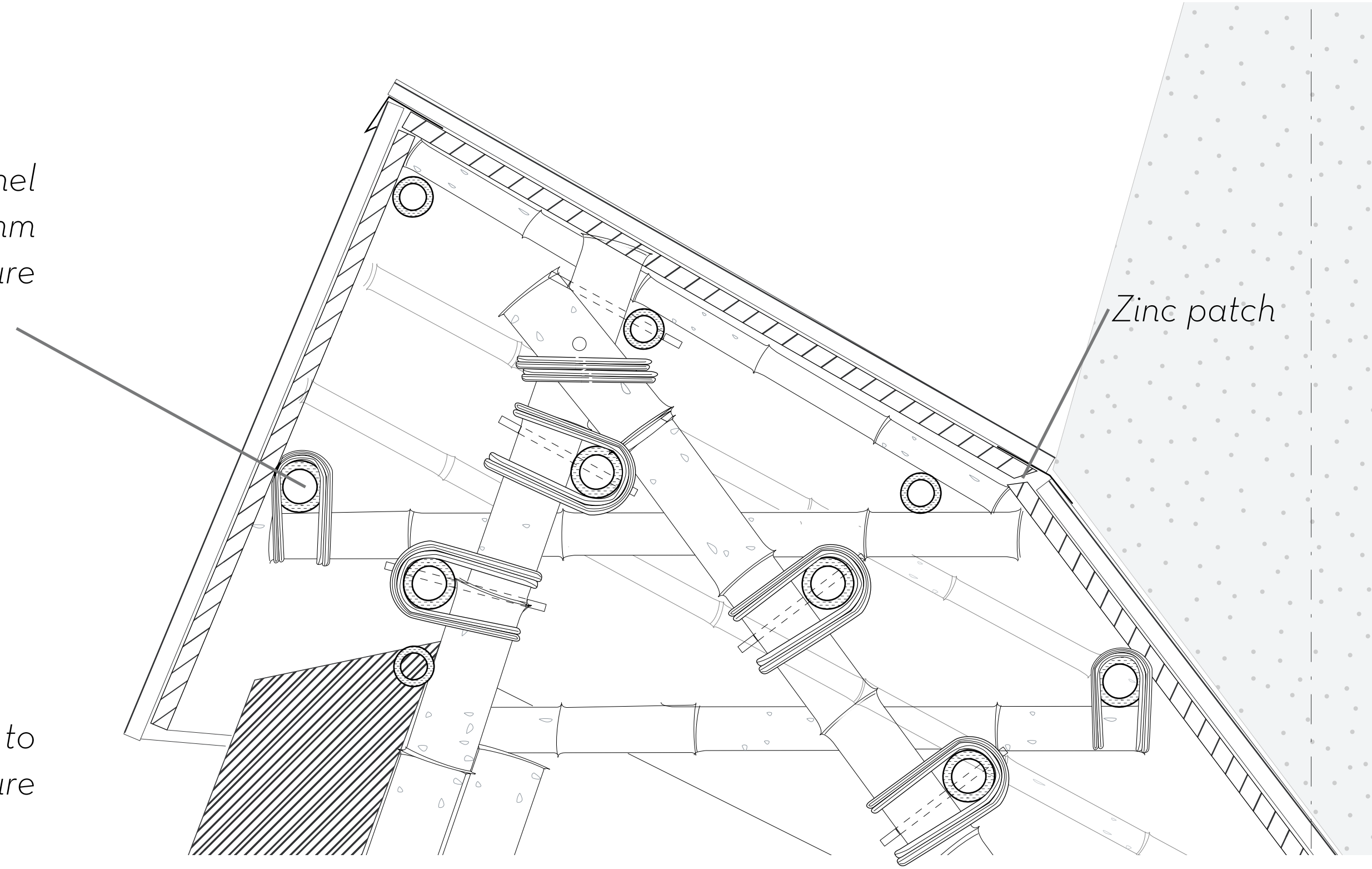

CLIMATE

Rain collection

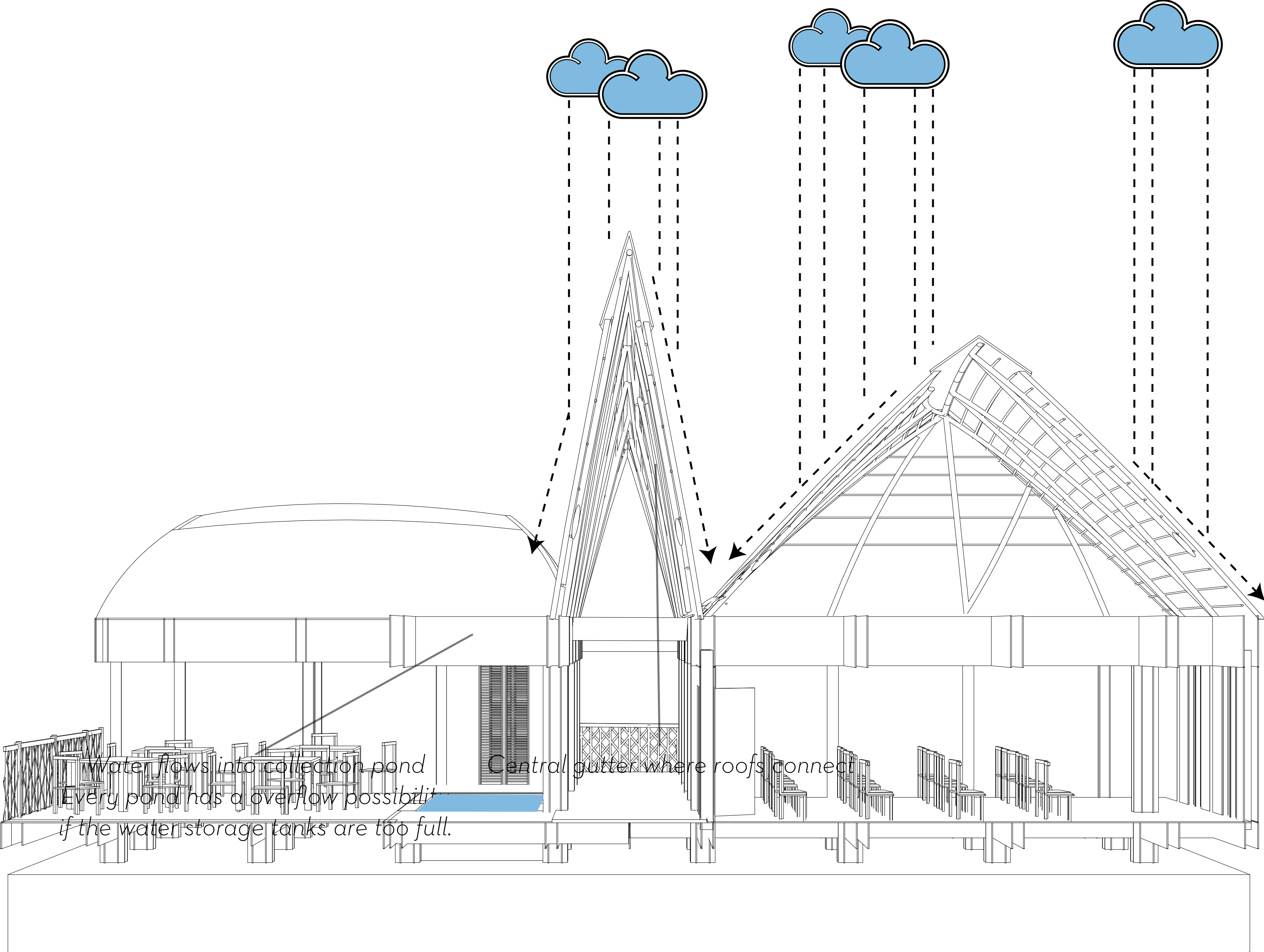

CLIMATE

1 - 20 section

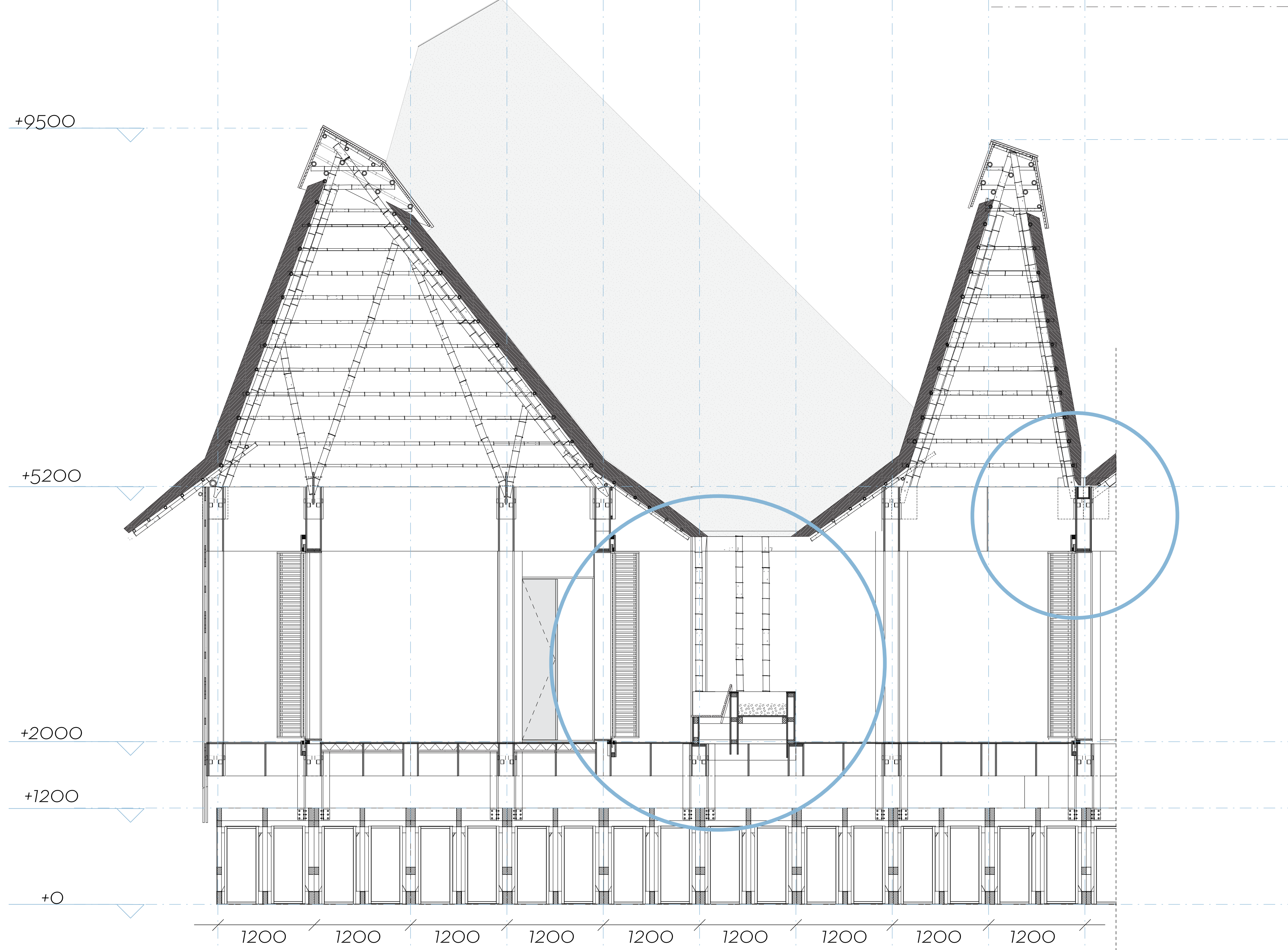

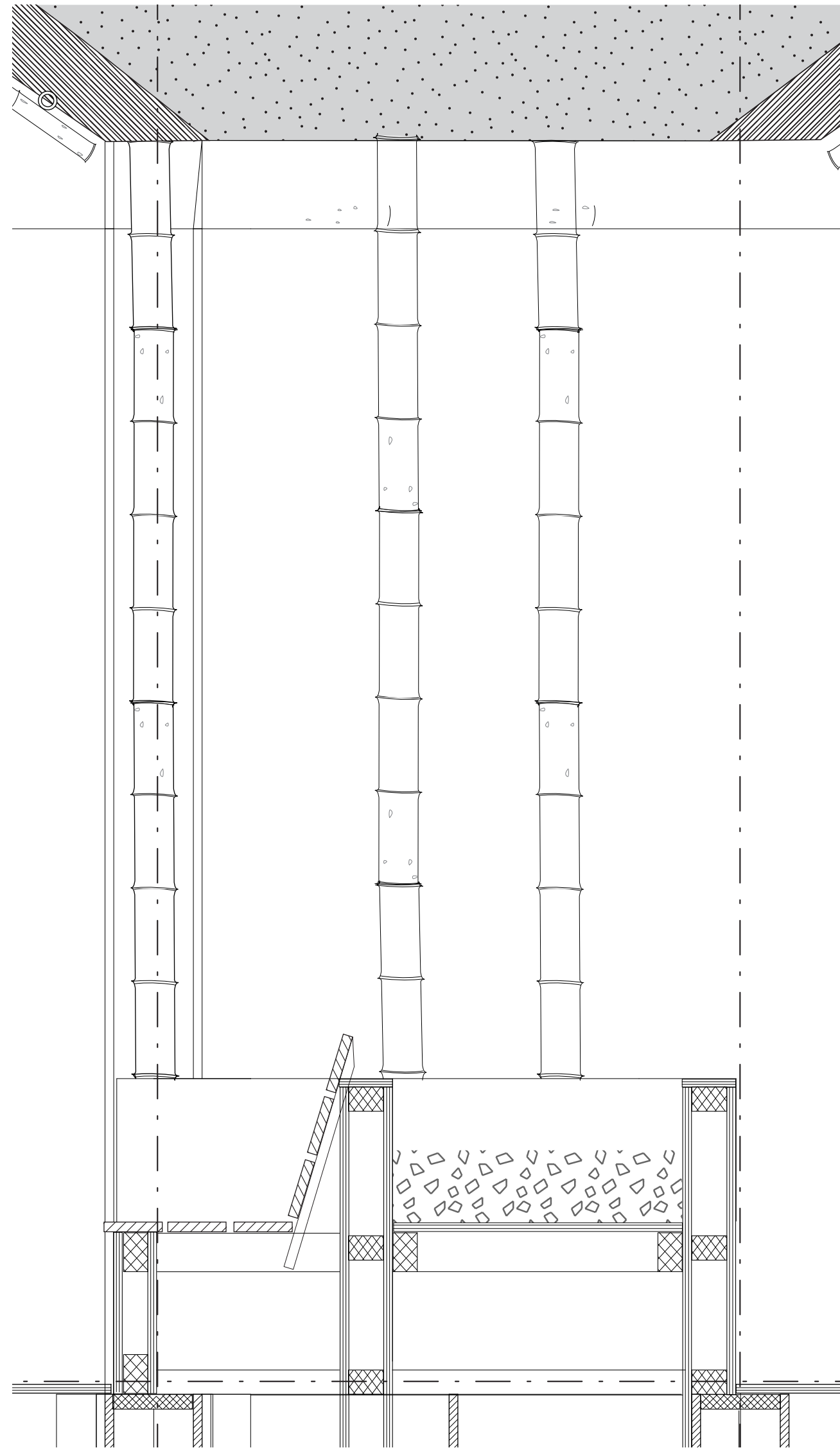

Roof next to courtyard directs rain water into the central pond.

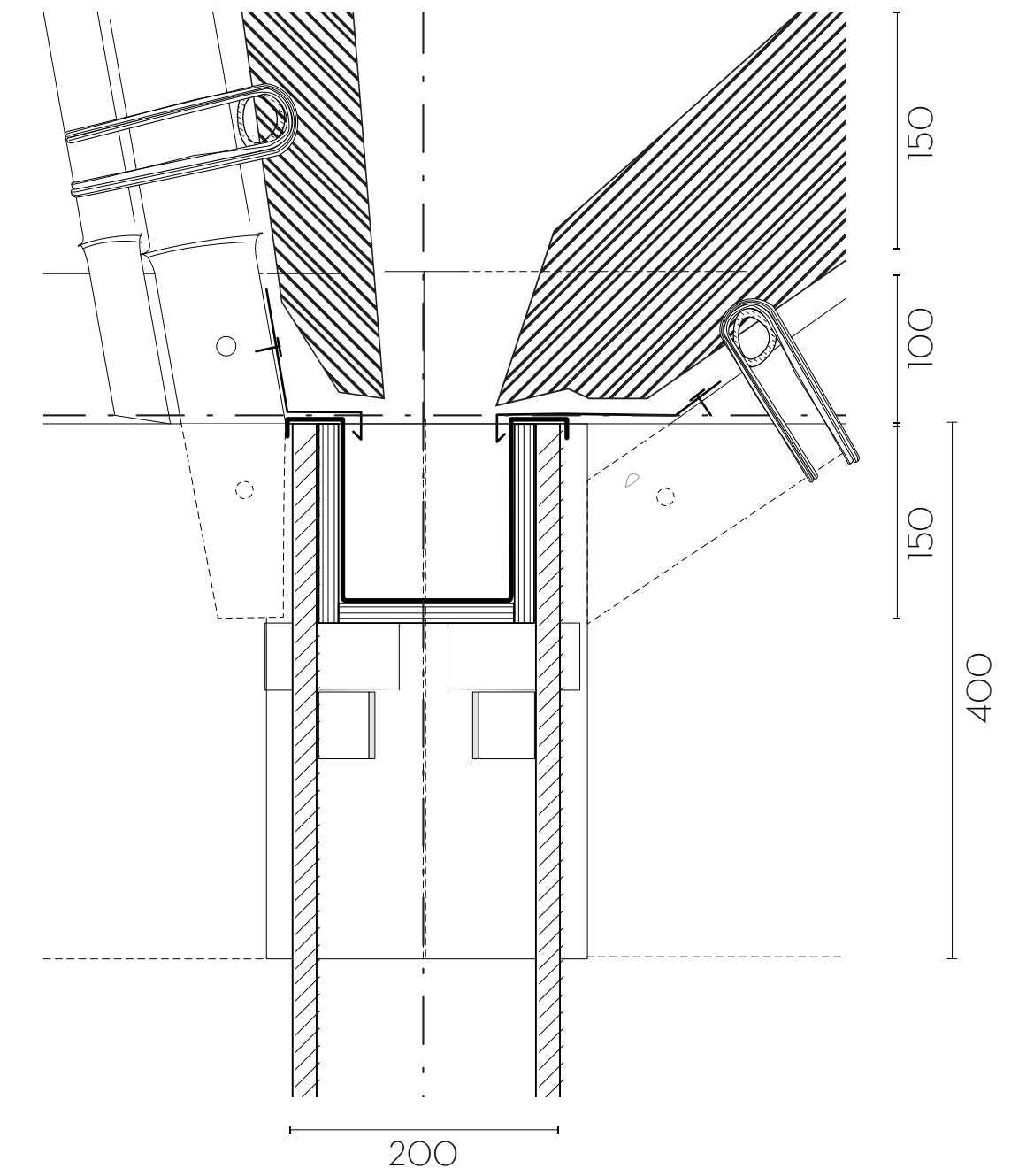

Central gutter detail

CLIMATE
Water and Energy

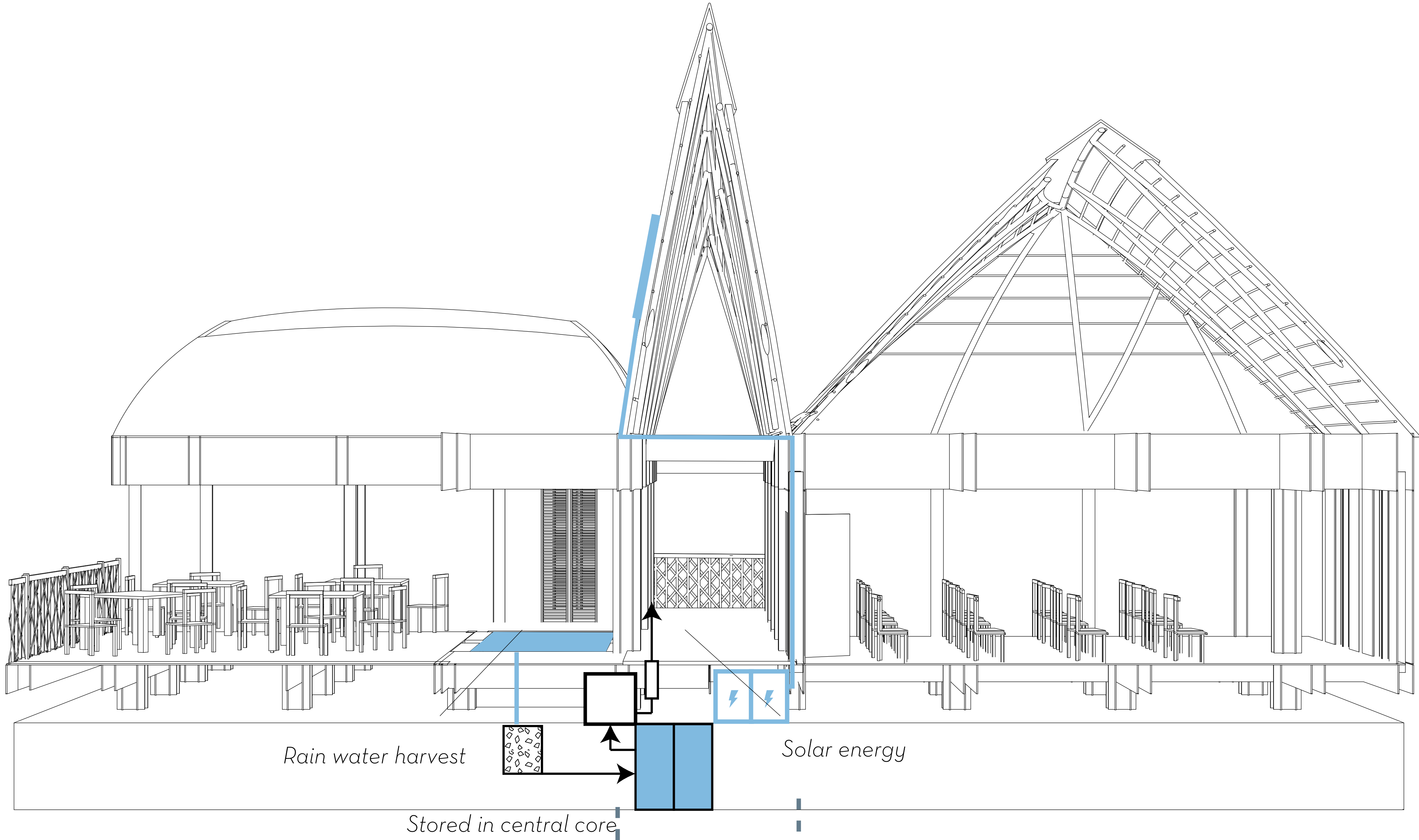

CLIMATE
Daylight concept

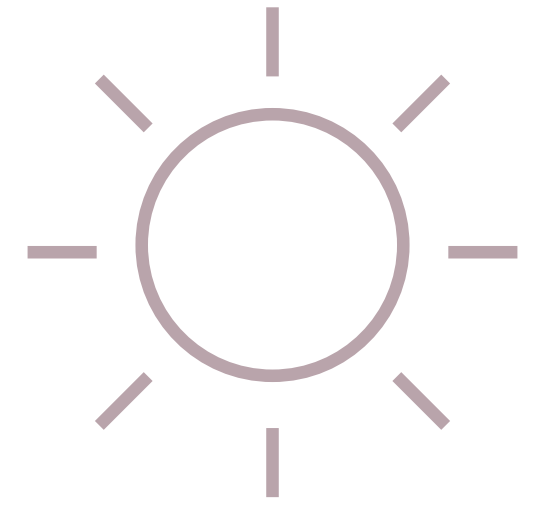

CLIMATE
Daylight entry

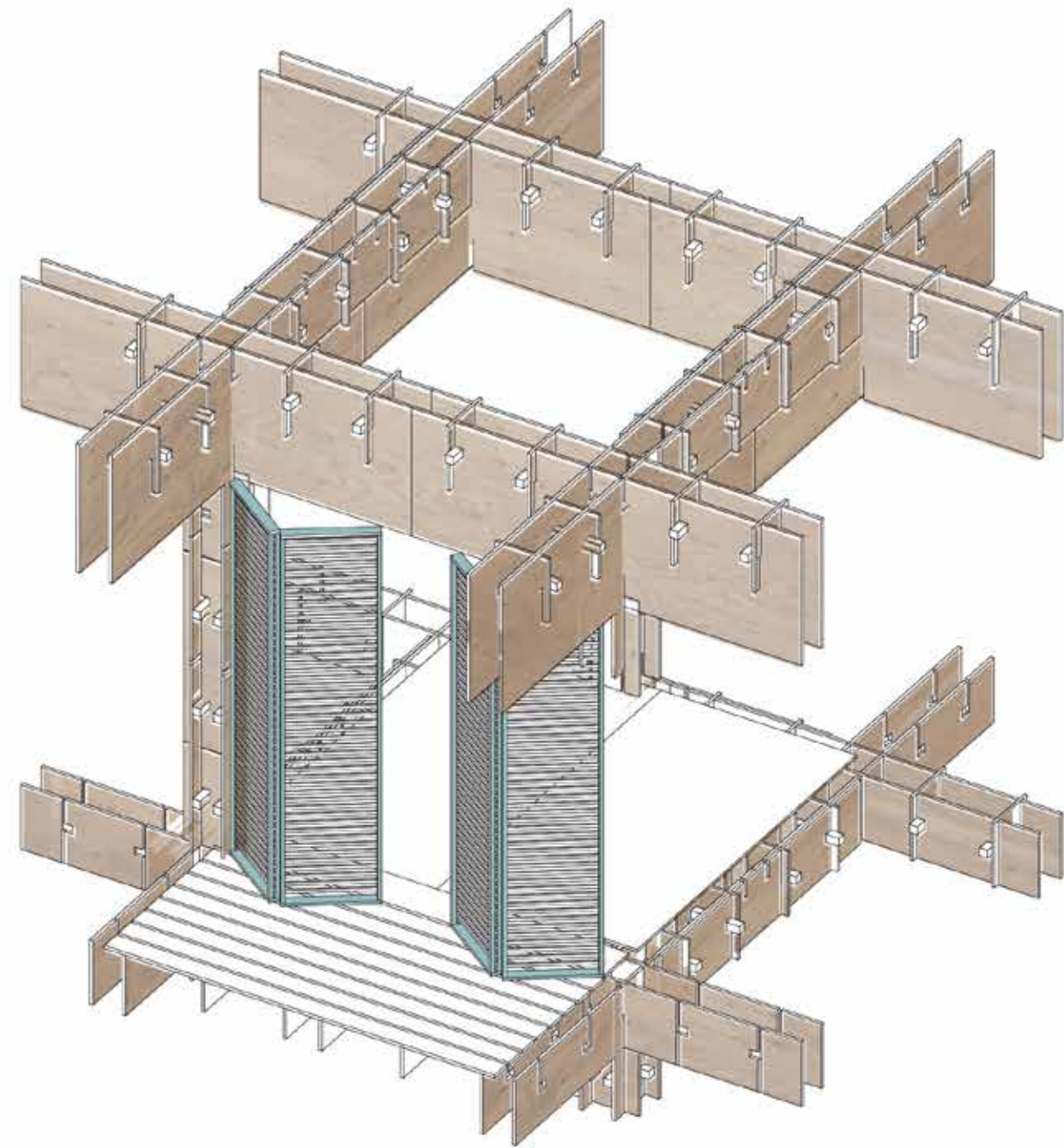

Bamboo shade doors

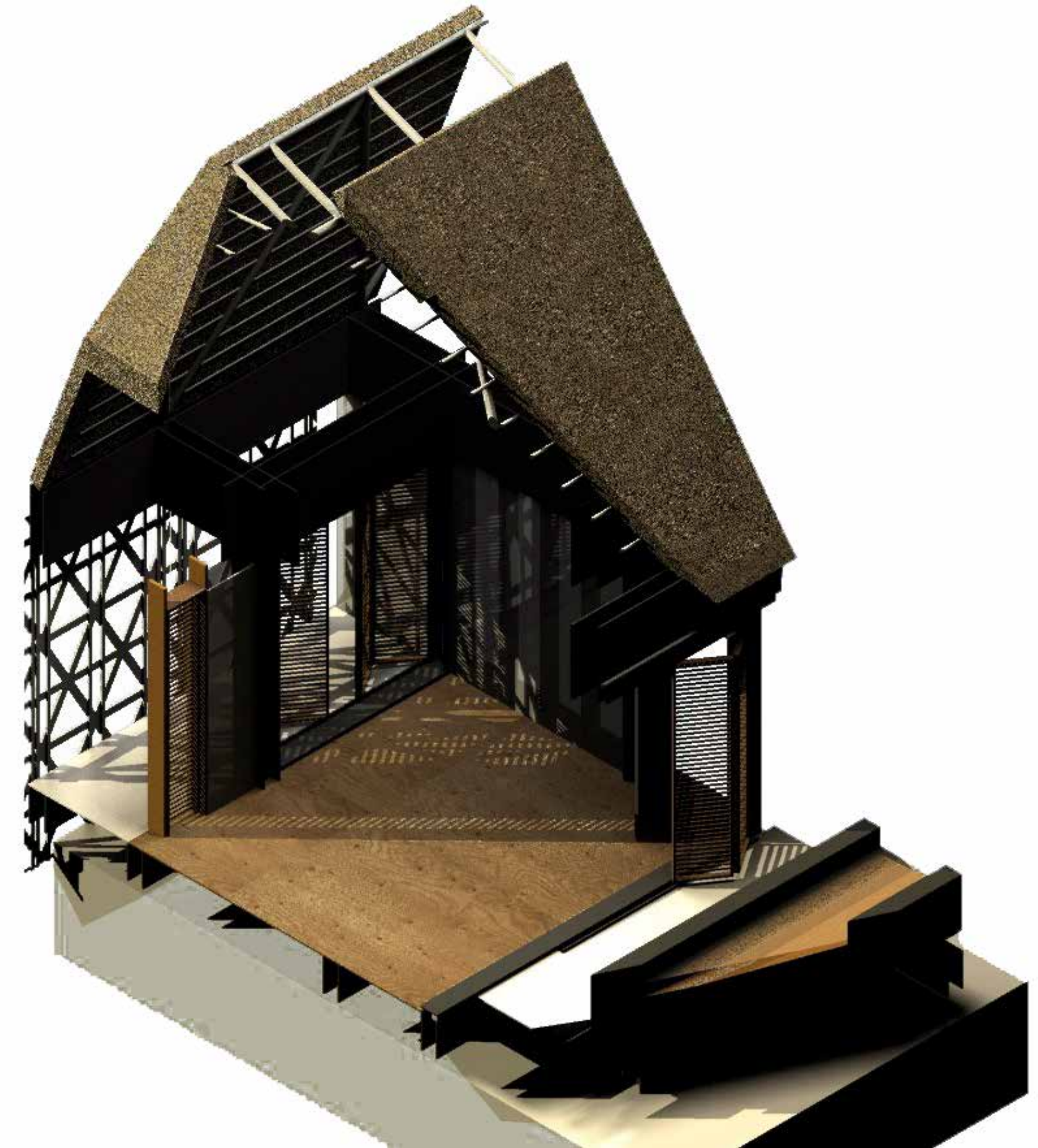

*Doors function as the shade panels
and allow movement to terraces*

EXAMPLE SITE

Analysis



DESIGN
Central Hall



CONCLUSION

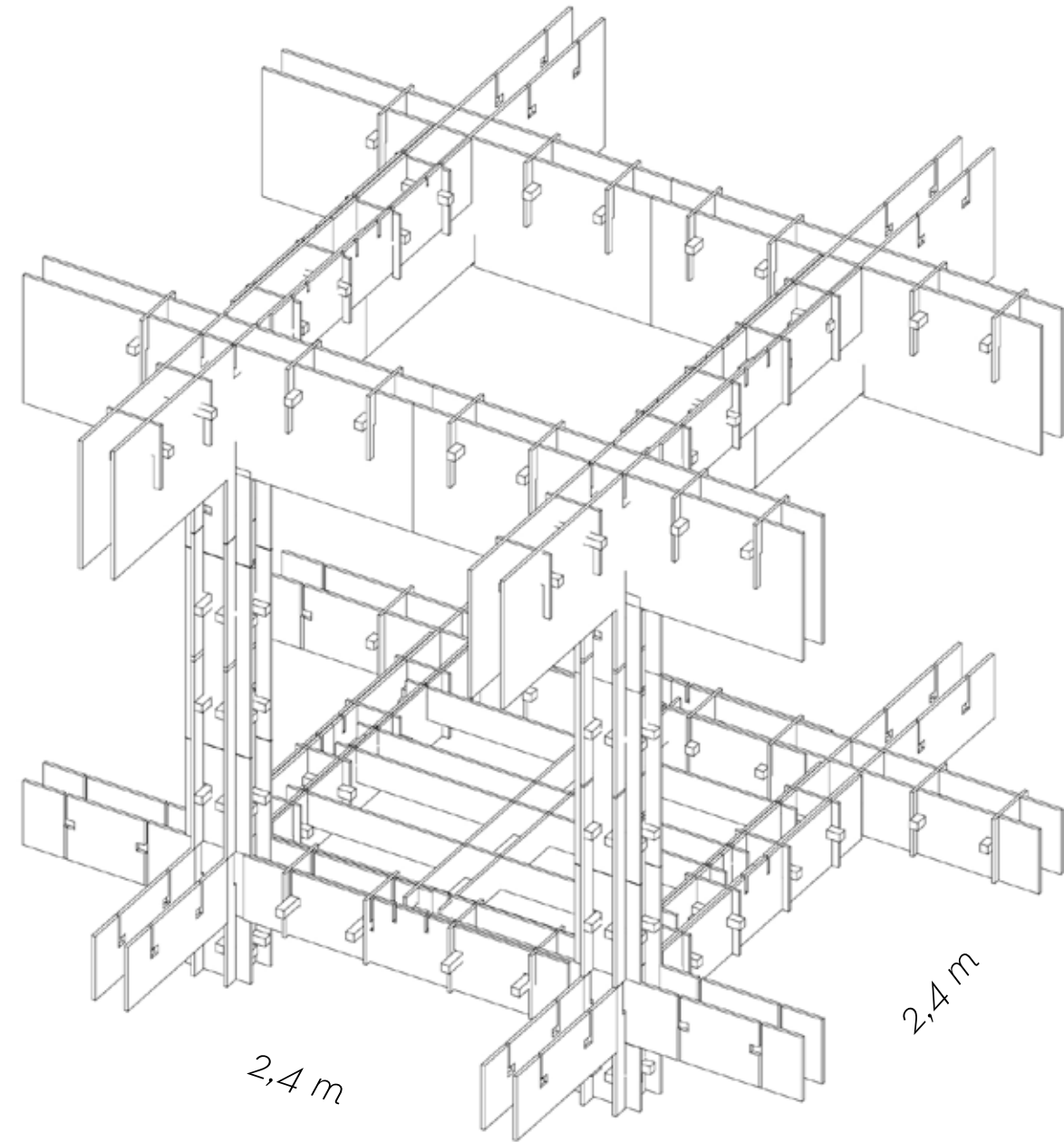

DEVELOP A *PERMANENT* SOLUTION FOR LOW INCOME, FLOOD PRONE AREAS BY OFFERING *FLOATING* HEALTHCARE AND MEDICAL TRAINING FACILITIES.

TO CREATE REAL SELF-RESILLIENCE, THE STRUCTURE SHOULD BE *BUILD* AND *OWNED* *LOCALLY*.

CONCLUSION

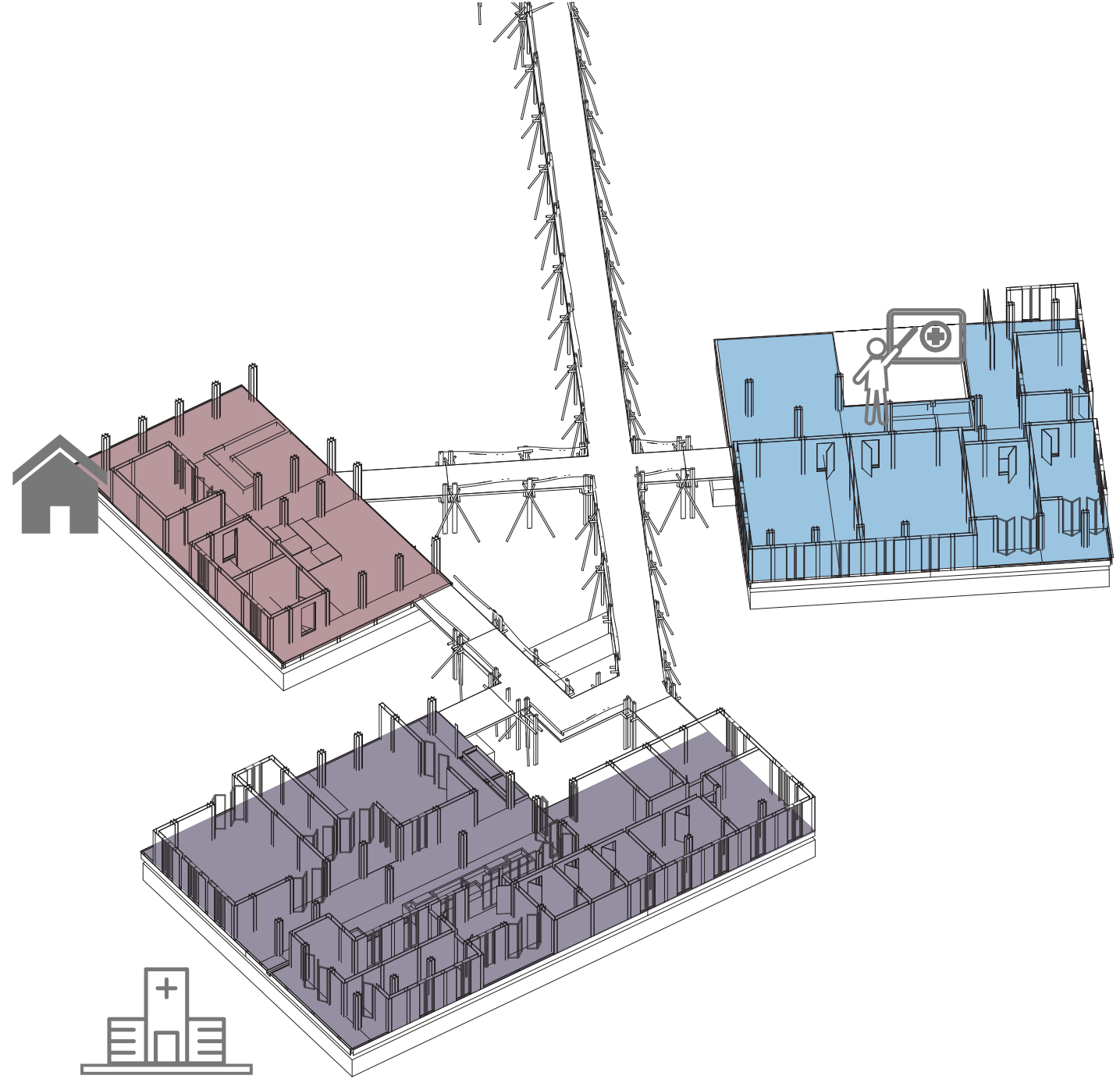
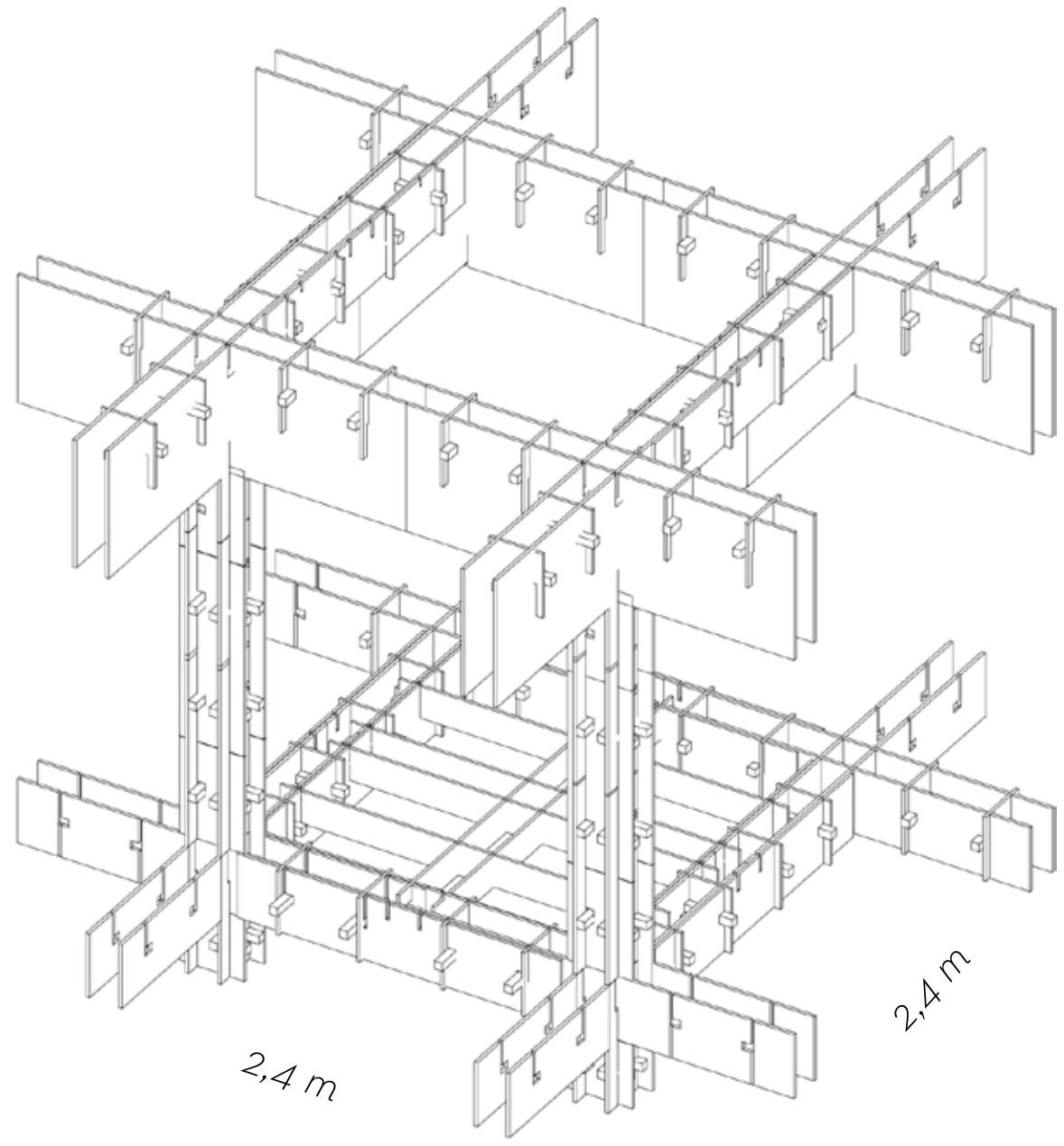

DEVELOP A *PERMANENT* SOLUTION FOR LOW INCOME, FLOOD PRONE AREAS BY OFFERING *FLOATING* HEALTHCARE AND MEDICAL TRAINING FACILITIES.

TO CREATE REAL SELF-RESILLIENCE, THE STRUCTURE SHOULD *BE BUILT AND OWNED LOCALLY.*

CONCLUSION

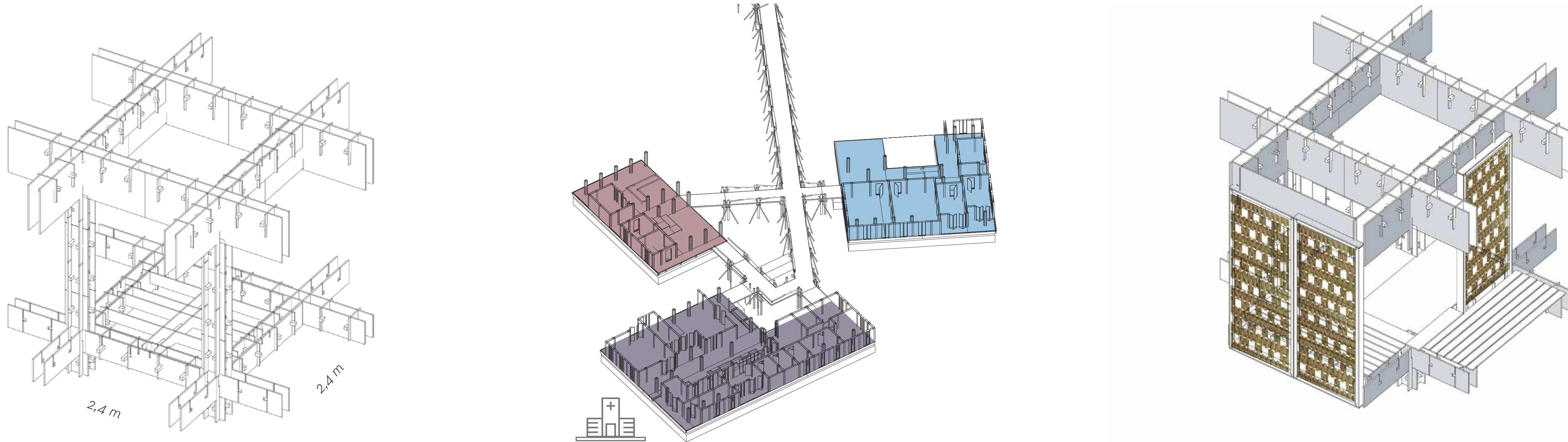

DEVELOP A *PERMANENT* SOLUTION FOR LOW INCOME, FLOOD PRONE AREAS BY OFFERING *FLOATING* HEALTHCARE AND MEDICAL TRAINING FACILITIES.

TO CREATE REAL SELF-RESILLIENCE, THE STRUCTURE SHOULD BE *BUILD* AND *OWNED* *LOCALLY*.

THANK YOU



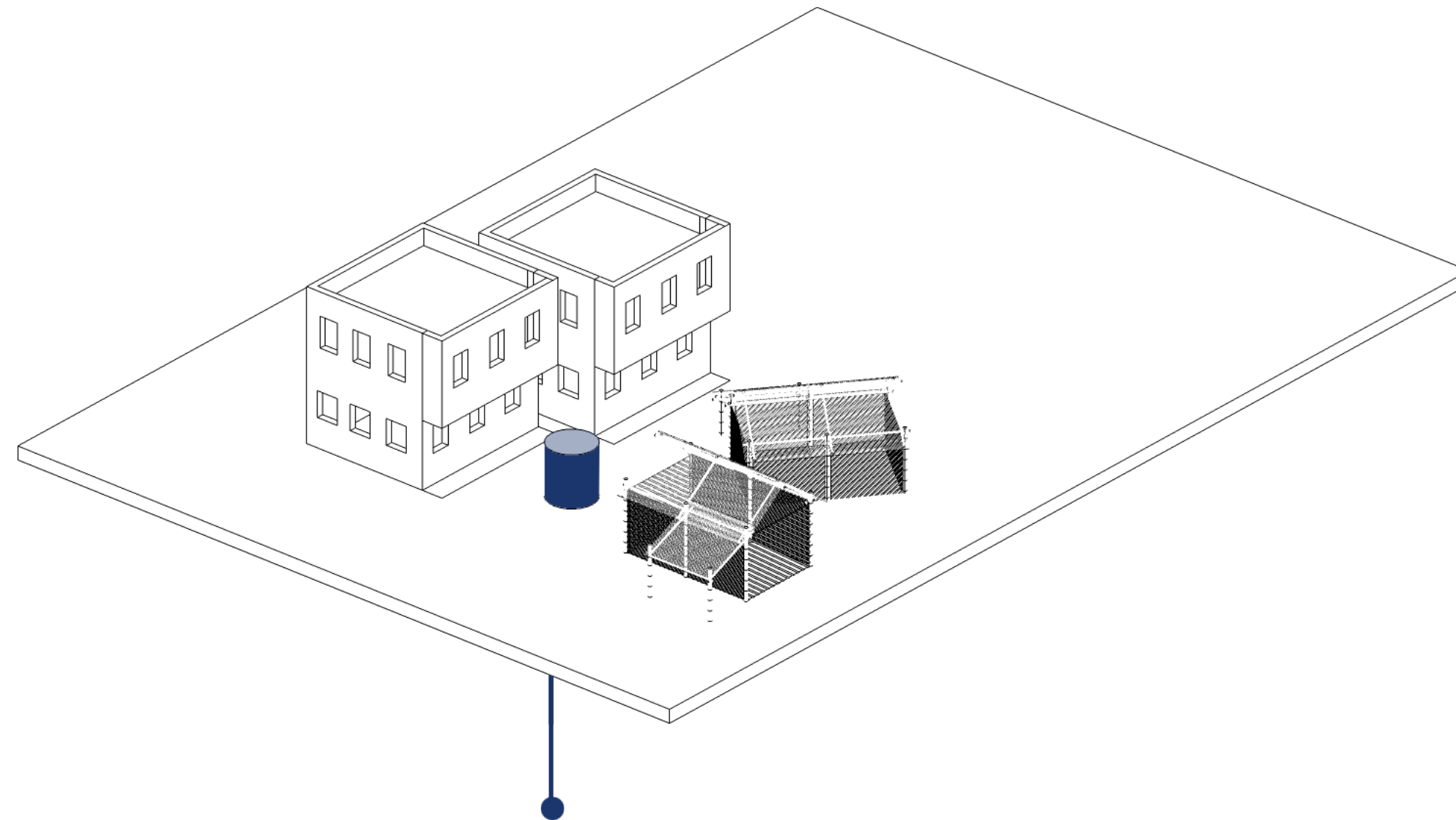

Clean Water demand

- “the daily average water consumption for the village was found to be 117.0 l per person per capita per day”

- “86 % do not have awareness about rainwater harvesting technology. This needs to be addressed immediately by changing public perception through media and by organizing public awareness programs.”

Source: Singh, O. (2012). A survey of household domestic water consumption patterns in rural semi-arid village, India

School Demand

- 1,5 Liter a day per student

- 40 students = 60 L a day = 1800 L a month

- Average = 300 mm per month in monsoon season
= 300 Liter / square meter
= **6 m²** needed to supply

Health clinic Demand

- 200 Liter a day

- Average = **20 m²** needed to supply

CURATIVE CARE

GENERAL CHECKUPS

MALARIA AND OTHER VECTOR BORNE DISEASES

Early detection of TB, Leprosy, Kala-Azar and other locally endemic communicable diseases and non-communicable diseases such as diabetes and cataract cases

JAPANESE ENCEPHALITIS (JE) VACCINE AND OTHER EPIDEMIC PRONE COMMUNICABLE DISEASES

MINOR SURGICAL PROCEDURES AND SUTURING

REPRODUCTIVE AND CHILD CARE

ANTE - NATAL CHECK UP AND RELATED SERVICES E.G. INJECTION - TETANUS TOXOID, IRON AND FOLIC ACID TABLETS

Referral for complicated pregnancies

Promotion of institutional deliveries

POST - NATAL CHECK UP

IMMUNIZATION CLINICS

Pulse polio

TREATMENT OF COMMON CHILDHOOD ILLNESS SUCH AS DIARRHEA,

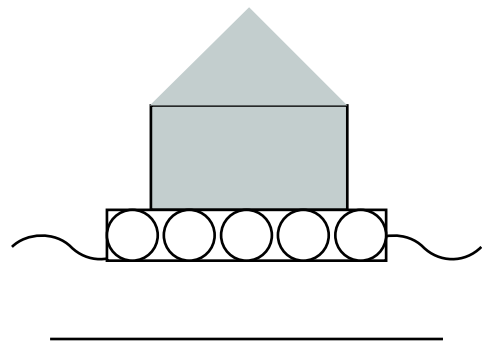
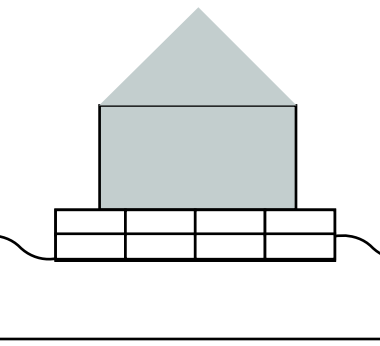
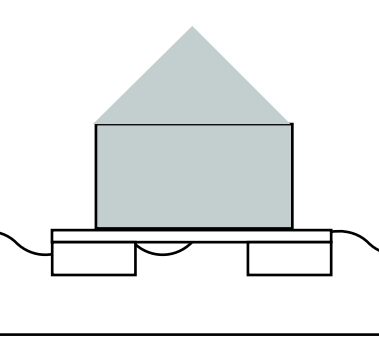
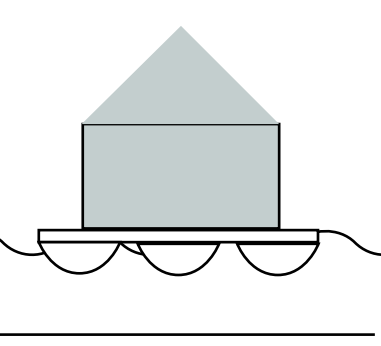
 <p>Floating Barrels</p>	 <p>Floating EPS-blocks</p>	 <p>Floating Barges</p>	 <p>Floating Local boats</p>	
+	-	-	+	Local availability
+	-	-	+	Local technology
+	-	-	+/-	Cost
+/-	+	-	+/-	Construction time
+/-	+	+	-	Durability
+	+/-	+	-	Maintenance
+	+	-	+/-	Weight

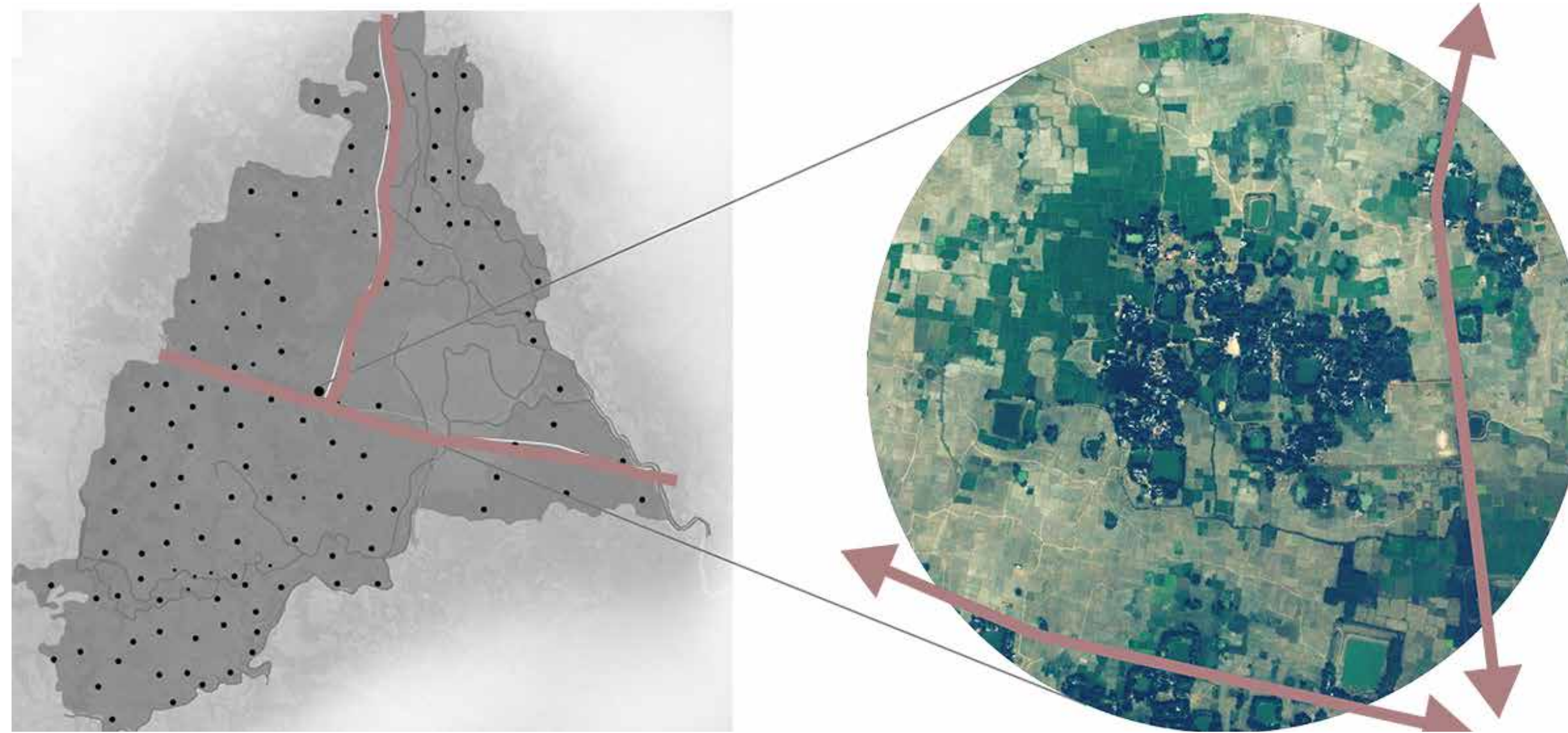

Village Marichya

Population: 4500
Main profession: Agriculture
School: No

EXTRA
Location

