

A Series Resonant Balancing Converter for Bipolar DC Grids on Ships

Yadav, Sachin; Qin, Zian; Bauer, Pavol

Publication date

2022

Document Version

Final published version

Published in

Proceedings of the 2022 24th European Conference on Power Electronics and Applications (EPE'22 ECCE Europe)

Citation (APA)

Yadav, S., Qin, Z., & Bauer, P. (2022). A Series Resonant Balancing Converter for Bipolar DC Grids on Ships. In *Proceedings of the 2022 24th European Conference on Power Electronics and Applications (EPE'22 ECCE Europe)* (pp. 1-8). IEEE. <https://ieeexplore.ieee.org/document/9907253>

Important note

To cite this publication, please use the final published version (if applicable). Please check the document version above.

Copyright

Other than for strictly personal use, it is not permitted to download, forward or distribute the text or part of it, without the consent of the author(s) and/or copyright holder(s), unless the work is under an open content license such as Creative Commons.

Takedown policy

Please contact us and provide details if you believe this document breaches copyrights. We will remove access to the work immediately and investigate your claim.

Green Open Access added to TU Delft Institutional Repository

'You share, we take care!' - Taverne project

<https://www.openaccess.nl/en/you-share-we-take-care>

Otherwise as indicated in the copyright section: the publisher is the copyright holder of this work and the author uses the Dutch legislation to make this work public.

A Series Resonant Balancing Converter for Bipolar DC Grids on Ships

Sachin Yadav, Zian Qin, Pavol Bauer

Delft University of Technology

Mekelweg 4

Delft, The Netherlands

Phone: +31 (0) 15 27 84399

Email: s.yadav-1@tudelft.nl, z.qin-2@tudelft.nl, p.bauer@tudelft.nl

URL: <https://www.tudelft.nl/>

Acknowledgments

This work was supported by Nederlandse Organisatie voor Wetenschappelijk Onderzoek (NWO), grant 17628.

Keywords

«Resonant converter», «DC-DC», «Bi-directional converters», «Bipolar DC».

Abstract

Balancing converters are an integral part of a bipolar dc grid. In this paper, we propose a balancing converter based on a series resonant converter topology. The converter operates in the capacitive region with phase shift between the upper and lower H-bridges. The converter operation is analyzed and verified with LTSpice simulation. A prototype is developed to verify the operation.

Introduction

Climate change is one of the main issues that concerns the existence of human beings across the globe. Greenhouse gas (GHG) emissions are considered the main culprit for this. The ship industry emits around 3% of all the GHG in the world [1]. To reduce the emissions, the International Maritime Organisation (IMO) has come out with regulations mandating ship manufacturers to increase the efficiency of future ships [2]. One of the ways to improve the efficiency of ships is electrification of the power train. DC grids on ships are the major contender for this [3]. These grids have several advantages such as enhanced dynamic performance, peak shaving, zero emission operation and strategic loading [3].

The dc grids can be unipolar or bipolar. Bipolar dc grids have several advantages when compared with unipolar dc grids [4] [5]. They have improved reliability because of multiple conductors/poles; if one pole is faulty then the other can be used to supply half of the power. They have increased flexibility because of more than one voltage level. Hence, bipolar dc grids are being considered for future dc grids on ships.

Balancing converters are an integral part of bipolar dc grids. Many topologies can be found in literature for these converters [6] [7] [8] [9] [10] [11]. One of the ways to form a bipolar dc grid on ships is using a three level converter to interface the synchronous generator. The balancing function can be achieved with the 3-phase multilevel converter topologies like Neutral Point Clamped and T-Type converter [6] [7]. These converters can be controlled in such a manner that voltage at the dc side remains balanced and no current flows in the neutral [12]. But, an unbalanced dc operation leads to increased total harmonic distortion on the ac side thus leading to higher losses in the machine interfaced with the converter [13]. Also, the size of the dc-link capacitors are needed to be increased to attenuate the effect of the unbalances [14]. It is also difficult to have a distributed architecture when these converters are used.

Other topologies of balancing converters include buck-boost, Cuk, and SEPIC converters [5] [10] [11]. These topologies are called inverting topologies which can be directly utilized as balancing converters in a bipolar dc grid [8]. Another interesting topology is a series-resonant converter topology. This converter is a non-inverting type topology. Hence, it can not be used as a balancing converter without some modifications. In this work, we designed a series-resonant balancing converter to show its utility as a balancing converter in bipolar dc grids.

The structure of this paper is as follows. The need for the balancing converter is detailed in the next section. Thereafter, the operating principle for the series resonant balancing converter is discussed. In the next section, the converter prototype along with the specifications in brief are shown. Subsequently, the results of the simulation and laboratory setup for the operation of the balancing converter are shown and discussed. Finally, the paper is concluded in the last section.

Need for balancing converter

Balancing converters are essential for bipolar dc grids when unequal loads are connected between +n and n- poles. Unequal power loading has an effect of shifting of voltage at the neutral of the system. In a bipolar grid with three conductor, there are multiple ways that the loads can be connected to the distribution lines. The loads can either be connected between the positive (+) and negative (-) poles or between a pole (+ or -) and neutral. In case of an isolated system (IT system), if there are any unbalanced connection of loads present in the system then the neutral voltage can shift from zero. It should be noted that there is no balancing converter present in the system. Also, the droop controlled converter only controls voltage between the two poles and not of the neutral. A 3 node 2 line 3 conductor system was simulated with unbalanced loads connected to grid using the method in [15] and [16]. The test case is given in Table I and the resulting node voltages are given in Fig. 1.

Table I: Case for simulating unbalanced power flow in a three node 2 line bipolar dc grid.

Time (ms)	n_{2+-}	n_{2+n}	n_{2n-}	n_{3+-}	n_{3+n}	n_{3n-}
0	0	0	0	0	0	0
10	-25kW	0	0	0	-2.5kW	0
20	-25kW	0	-1kW	-23.5kW	-2.5kW	0
30	-25kW	0	0	0	0	0
40	0	0	0	0	0	0

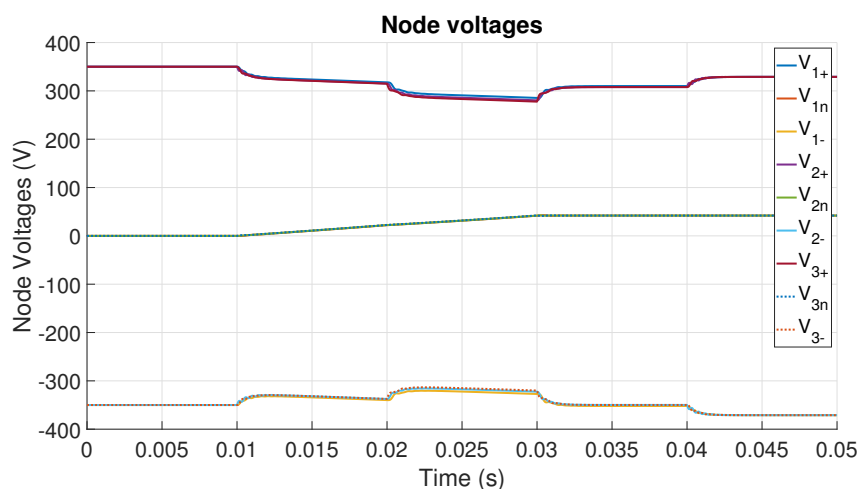

Fig. 1: Node voltages of a 3 node 2 line system with the effect of unbalancing on the neutral voltage.

It can be observed in Fig. 1, when the loads between the neutral and the poles is turned on then the voltage at the neutral shifts from zero. The shift in the neutral voltage can lead to various issues in the

system. If the neutral voltage shift a lot then the drives can suddenly shut down in under-voltage or over-current fault. On a ship, this can lead to perilous condition for the people and equipment. Apart from that, the system efficiency decreases when current flows in the neutral conductor during the unbalance [4]. Hence, balancing converters are needed to balance the power flowing through both the poles.

Converter operating principle

The converter is based on a series-resonant converter topology as shown in Fig. 2. This topology is conventionally used as non-inverting. However, in our application, this topology is used as an inverting topology.

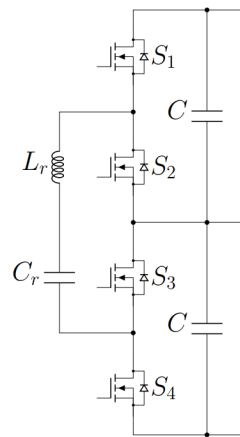

Fig. 2: Balancing converter based on a series resonant converter topology.

The operating principle of the converter is given below. The dead time between the switching has been neglected for this analysis.

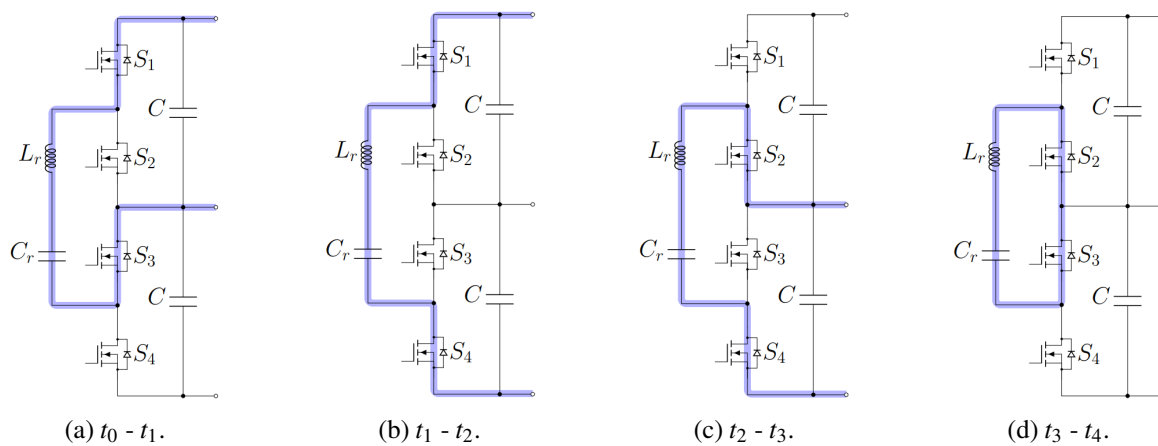

Fig. 3: Operation of the resonant converter in different time periods.

- **$t_0 - t_1$:** In this state, switches S1 and S3 are conducting. The resonant capacitor C_r is charging and current is limited by the resonant inductor L_r .
- **$t_1 - t_2$:** In this state, switch S3 is turned off and switches S1 and S4 are conducting. Hence, there is a higher voltage present across the resonant tank. Due to this stage, the charge is pumped into the resonant capacitor. This extra charge stored in the capacitor is used to boost the voltage of the capacitor.
- **$t_2 - t_3$:** In this state, switch S1 is turned off and S2 is turned on. The resonant tank is connected to the neutral and negative pole through switches S2 and S4. The inductor current reverses direction and the capacitor is also discharged as the energy is transferred to the load.

- $t_3 - t_4$: In this state, switch S4 is turned off and S3 is turned on. Hence, the resonant tank current freewheels through the switch diodes.

It should be noted that the stages $t_1 - t_2$ and $t_3 - t_4$ can be generated by a phase shift between the upper half bridge (consisting switches S1 & S2) and lower half bridge (consisting switches S3 & S4).

The power flow through the converter can be found out by solving the second order differential equations for the resonant tank. The power flow as a function of the operating frequency is given by (1). All the quantities except switching frequency are kept fixed.

$$P(f_{sw}) = 4C_r f_{sw} V_d \left[\frac{V_d}{2} - \frac{\sqrt{4I_{l1}^2 Z_0^2 \sec^2\left(\frac{\omega_0}{4f_{sw}}\right) + V_d^2}}{2} - I_{l1} Z_0 \tan\left(\frac{\omega_0}{4f_{sw}}\right) \right] \quad (W) \quad (1)$$

Also, the phase shift needed to achieve the change in current during the interval t_1-t_2 is given by (2):

$$\phi(f_{sw}) = \frac{2\pi f_{sw}}{\omega_0} \left[\pi - 2 \tan^{-1} \left(\frac{V_d + \sqrt{4I_{l1}^2 Z_0^2 \sec^2\left(\frac{\omega_0}{4f_{sw}}\right) + V_d^2} + 2I_{l1} Z_0 \tan\left(\frac{\omega_0}{4f_{sw}}\right)}{2I_{l1} Z_0} \right) \right] \quad (rad) \quad (2)$$

where, V_d is the input voltage between one pole and neutral, I_{l1} is the current through the inductor at instant t_2 , Z_0 is the characteristic impedance of the resonant tank, and ω_0 is the resonant angular frequency of the tank. The power flow when the current I_{l1} is 3.5A is shown in Fig. 4. It should be noted that the phase shift also changes with frequency according to (2).

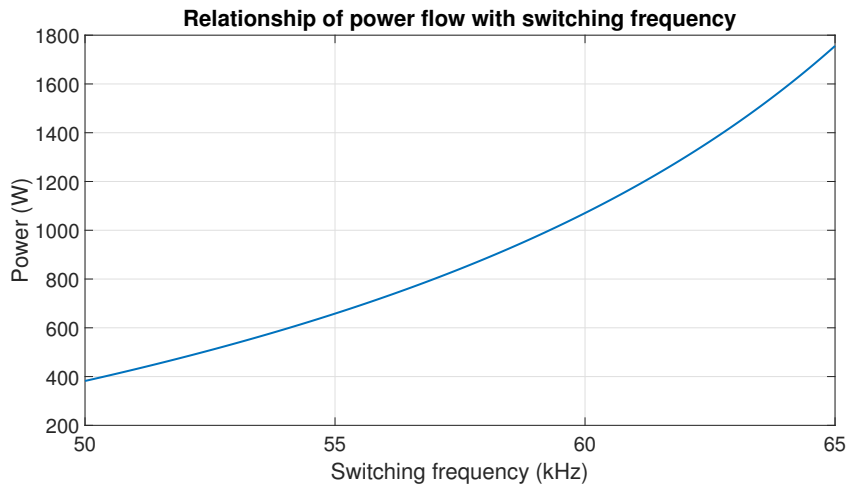

Fig. 4: Power flow dependence on frequency of the converter.

Converter prototype

A balancing converter was designed for a bipolar dc grid with voltage of ± 350 VDC. The main specifications of the converter are given in Table II. The resonant frequency of the tank was found to be approximately 78 kHz.

Table II: Specifications of the designed converter.

Parameter	Value
Rated power	2 kW
Resonant inductance	7 μH
Resonant capacitance	594 nF

The prototype of the converter is shown in Fig. 5. The resonant converter are put on the top of the PCB; the resonant inductor, semiconductor half bridge modules and dc link capacitors are installed on the both side of the PCB.

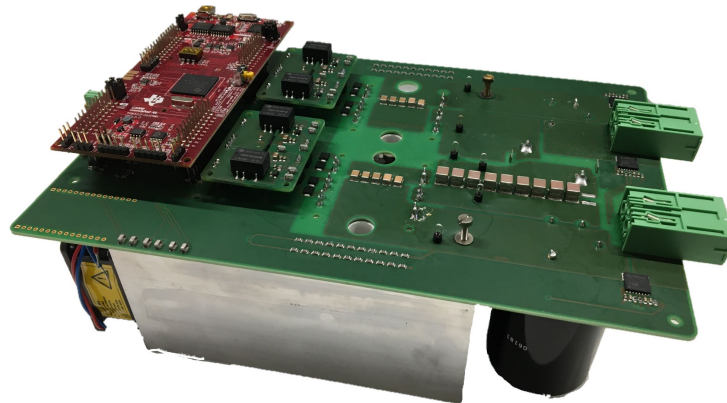

Fig. 5: Prototype of the converter.

Results

The schematic for testing the balancing converter is shown in Fig. 6. The main components are the source converters, load converter, balancing converter and the lumped line elements. The source converter are used to create a bipolar dc supply. The source converter in our setup is Agilent Technologies N5772A. The load converter is connected only between the neutral and negative pole to simulate a total imbalance of power flow. When the system is powered on without the balancing converter then the power is supplied only through the source converter connected between the neutral and negative pole. The balancing converter is used to balance the power flowing from both the source converters. When the balancing converter is turned on, the current flowing through the two source converter should be equal. This will be illustrated through the test results shown in subsequent figures. The load converter in our study is Delta Elektronika SM1500-CP-30. The lumped line elements are π -model for a 100m long two conductor cable.

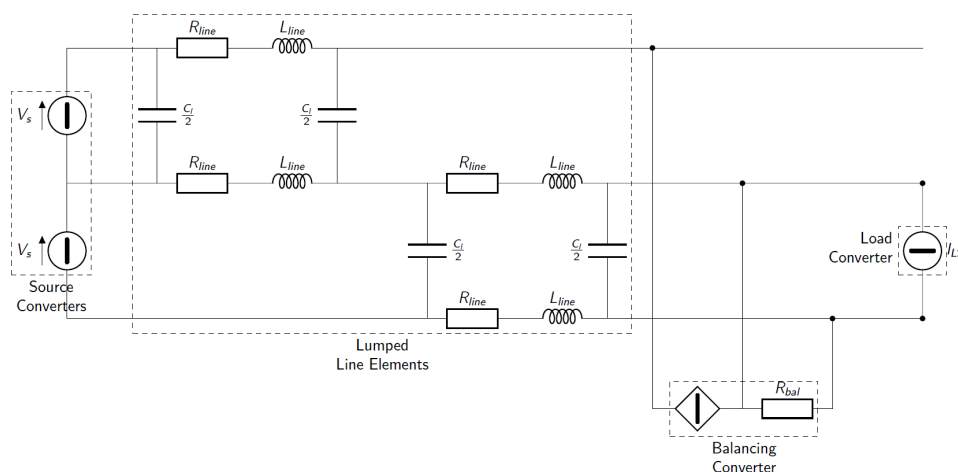

Fig. 6: Test bench schematic diagram.

The test setup in the laboratory is shown in Fig. 7. It consists of the source and load converters on the right; the balancing converter and lumped lime elements are on the left. In this setup, two lumped line elements are connected in series. Due to this, the impedance in the neutral line increases as two resistors and inductors are connected in series. This assumption is correct as the inductance and resistance increases as the cable cross section area decreases [17].

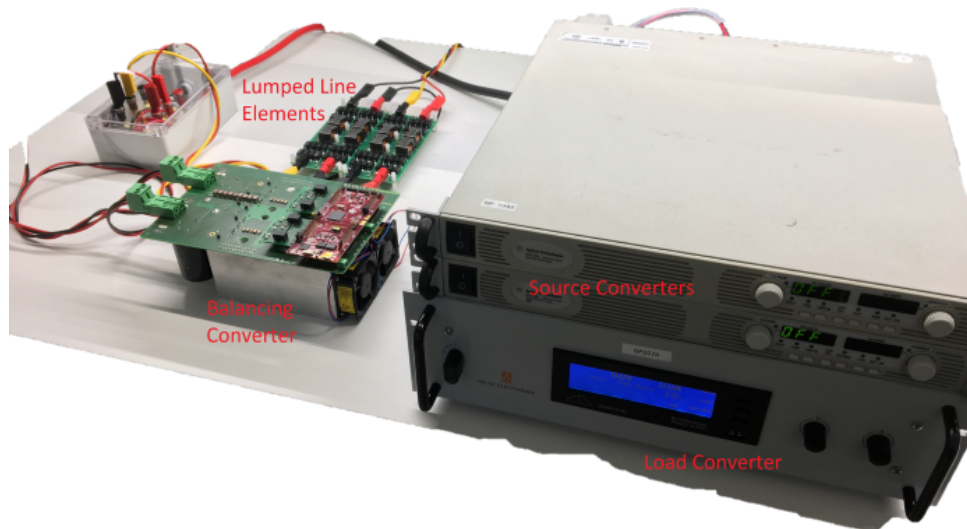

Fig. 7: Lab test setup.

The model of converter along with the other components of setup were simulated in LTSpice. The resulting resonant capacitor voltage and resonant inductor current are shown in Fig. 8. In this simulation, the load is connected between the neutral and negative poles. The load is a current sink with a value of 5A. The source converter are programmed to supply a voltage of ± 350 VDC. The switches operate at 65 kHz with 50% duty cycle. A dead time of 100ns is inserted between the switch pairs S_1, S_2 and S_3, S_4 . The phase shift between the upper half bridge and lower half bridge is set at 3.6 degrees. The frequency and phase shift required for a power flow of 1.75 kW were calculated using (1) and (2).

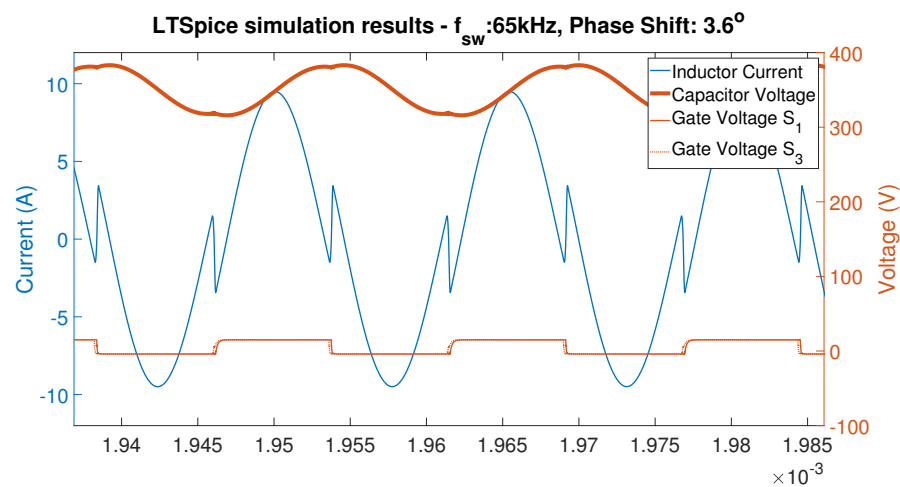

Fig. 8: Results of the LTSpice simulation

The results of the tests done in the laboratory are shown in Fig. 9 and Fig. 10. In this work, the converter is tested only at a single operating point. A closed loop control is beyond the scope of this work. The source converter supply ± 350 VDC and the load converter is set to sink a current of 5 A as shown in Fig. 10. The oscilloscope signals consists of the inductor current, capacitor voltage and the gate signal for switches S_1 and S_3 . The inductor current is measured using a Rogowski coil having a sensitivity of 50mV/A. The balancing converter operates with a phase shift of 3.6 degrees between the switch S_1 and S_3 and switching frequency of 65 kHz. The current output from the source converter is balanced with a minor difference of 0.06 A between the upper and lower source converters.

It can be seen from the oscilloscope output that the real life results match closely with the simulation results but not perfectly. One of the reasons of the imperfections can be the varying parameters of

inductance, capacitance and resistance during the tests. Also, the microcontroller has a certain resolution of setting the frequency and phase shift which differ slightly from the simulation. A phase shift of 3.6 deg at a frequency of 65kHz corresponds to approximately 154 ns. Precisely achieving such low phase shift was found out to be difficult during the testing of the converter. Hence, there are deviations between the actual frequency and phase shift with those in the simulation.

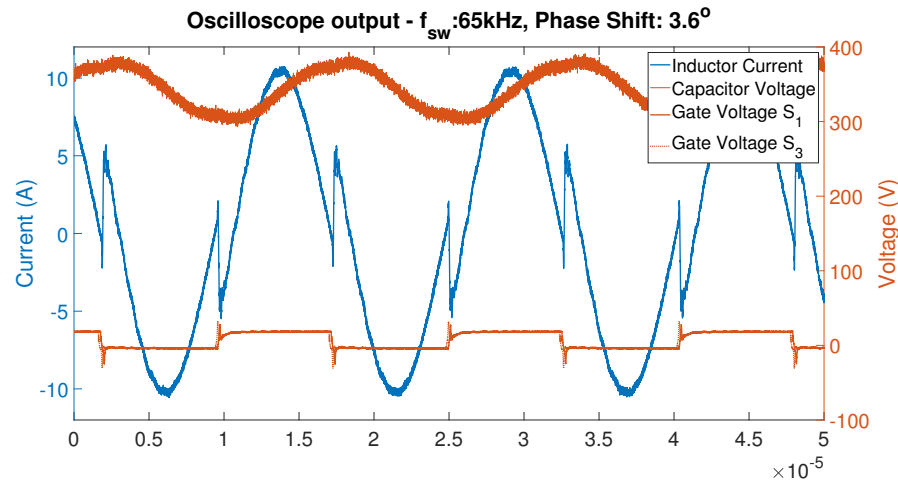

Fig. 9: Experimental results - oscilloscope output of the tests done with the converter.

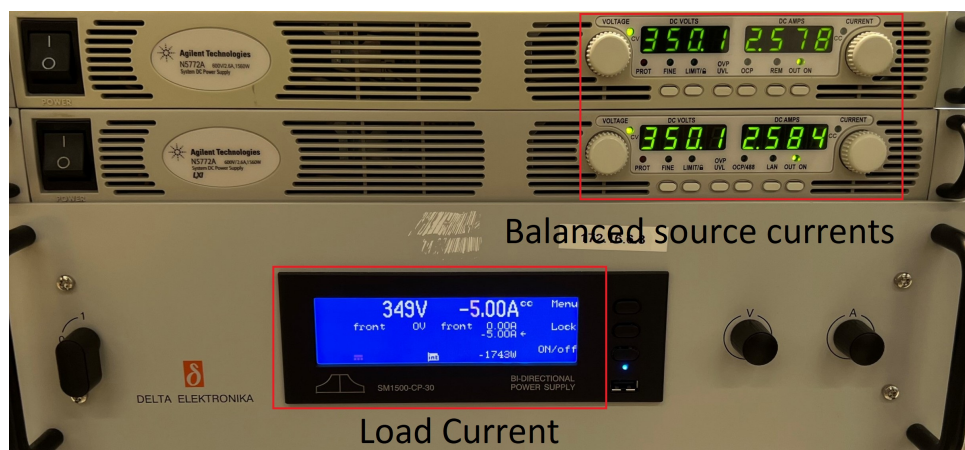

Fig. 10: Experimental results - voltage and current of the source and load converters.

Conclusion

In this paper, the use of a series resonant converter for balancing a bipolar dc grid is shown. The proposed converter is operated in the capacitive region. By changing the switching frequency of the converter and phase shift between the upper and lower half bridges of the converter, the power flow can be changed. The simulation results for balancing a load of 1.75kW connected between the neutral and negative pole is shown. A prototype of the balancing converter was built to experimentally verify the simulation results. The experimental results match closely with the simulations however not perfectly. The reason for the mismatch are also discussed. In the future, a closed loop control shall be developed for the converter.

References

- [1] T. Smith, J. Jalkanen, B. Anderson, J. Corbett, J. Faber, S. Hanayama, E. O'keeffe, S. Parker, L. Johansson, L. Aldous et al., "Third IMO GHG Study," 2014.
- [2] S. Karim, "Reduction of emissions of greenhouse gas (ghg) from ships," in Prevention of Pollution of the Marine Environment from Vessels. Springer, 2015, pp. 107–126.

- [3] A. J. Sorensen, R. Skjetne, T. Bo, M. R. Miyazaki, T. A. Johansen, I. B. Utne, and E. Pedersen, "Toward Safer, Smarter, and Greener Ships: Using Hybrid Marine Power Plants," *IEEE Electrification Magazine*, vol. 5, no. 3, pp. 68–73, Sep. 2017. [Online]. Available: <http://ieeexplore.ieee.org/document/8025702/>
- [4] B. S. H. Chew, Y. Xu, and Q. Wu, "Voltage Balancing for Bipolar DC Distribution Grids: A Power Flow Based Binary Integer Multi-Objective Optimization Approach," *IEEE Transactions on Power Systems*, vol. 34, no. 1, pp. 28–39, Jan. 2019.
- [5] S. Yadav, Z. Qin, and P. Bauer. "Bipolar DC grids on ships: possibilities and challenges," *e & i Elektrotechnik und Informationstechnik* (2022): 1-10.
- [6] J. Lago, J. Moia, and M. L. Heldwein, "Evaluation of power converters to implement bipolar DC active distribution networks – DC-DC converters," in 2011 IEEE Energy Conversion Congress and Exposition. Phoenix, AZ, USA: IEEE, Sep. 2011, pp. 985–990.
- [7] J. Moia, J. Lago, A. J. Perin, and M. L. Heldwein, "Comparison of three-phase PWM rectifiers to interface Ac grids and bipolar DC active distribution networks," in 2012 3rd IEEE International Symposium on Power Electronics for Distributed Generation Systems (PEDG). Aalborg: IEEE, Jun. 2012, pp. 221–228.
- [8] F. Wang, Z. Lei, X. Xu, and X. Shu, "Topology Deduction and Analysis of Voltage Balancers for DC Micro-grid," *IEEE Journal of Emerging and Selected Topics in Power Electronics*, vol. 5, no. 2, pp. 672–680, Jun. 2017.
- [9] G. Van den Broeck, J. Beerten, M. Dalla Vecchia, S. Ravyts, and J. Driesen, "Operation of the full-bridge three-level DC–DC converter in unbalanced bipolar DC microgrids," *IET Power Electronics*, vol. 12, no. 9, pp. 2256–2265, Aug. 2019.
- [10] P. Najafi, A. Houshmand Viki, and M. Shahparasti, "Evaluation of Feasible Interlinking Converters in a Bipolar Hybrid Microgrid," *Journal of Modern Power Systems and Clean Energy*, vol. 8, no. 2, pp. 305–314, 2020.
- [11] S. Rivera, R. Lizana F., S. Kouro, T. Dragicevic, and B. Wu, "Bipolar DC Power Conversion: State-of-the-Art and Emerging Technologies," *IEEE Journal of Emerging and Selected Topics in Power Electronics*, vol. 9, no. 2, pp. 1192–1204, Apr. 2021.
- [12] S. Rivera, B. Wu, S. Kouro, V. Yaramasu, and J. Wang, "Electric Vehicle Charging Station Using a Neutral Point Clamped Converter With Bipolar DC Bus," *IEEE Transactions on Industrial Electronics*, vol. 62, no. 4, pp. 1999–2009, Apr. 2015.
- [13] B. Wu and M. Narimani, *High-power converters and AC drives*. John Wiley & Sons, 2017.
- [14] J. Pou, R. Pindado, D. Boroyevich, and P. Rodríguez, "Evaluation of the low-frequency neutral-point voltage oscillations in the three-level inverter," *IEEE transactions on industrial electronics*, vol. 52, no. 6, pp. 1582–1588, 2005.
- [15] N. H. van der Blij, L. M. Ramirez-Elizondo, M. T. Spaan, and P. Bauer, "A state-space approach to modelling dc distribution systems," *IEEE Transactions on Power Systems*, vol. 33, no. 1, pp. 943–950, 2017.
- [16] S. Yadav, N. H. Van Der Blij, and P. Bauer, "Modeling and stability analysis of radial and zonal architectures of a bipolar dc ferry ship," in 2021 IEEE Electric Ship Technologies Symposium (ESTS). IEEE, 2021, pp. 1–8.
- [17] William A. Thue, ed. *Electrical Power Cable Engineering*. CRC Press, 2017.