



# MASTER THESIS

*DESIGNING A TOILETING SOLUTION FOR FEMALE  
ELECTRIC POWERED WHEELCHAIR USERS*

Jorinde Smits 4501071  
Intergrated product design



# I Contact Information

**Client**

Marie-Jose Calkhoven

**Delft University of Technology**

Faculty of Industrial Design Engineering  
Landbergstraat 15  
2628 CE Delft  
+31 15 278 4750

Project chair: Ir. I. A. Ruiten  
Department of Industrial Design,  
section Applied Ergonomics and Design

Project mentor: Ir. C.P.J.M. Kroon  
Department of Design Engineering,  
section Product Architecture Design

**Jorinde Smits**

4501071

[jorinde.smits@gmail.com](mailto:jorinde.smits@gmail.com)

MSc Integrated Product Design  
Faculty of Industrial Design Engineering  
Delft University of Technology



# II Acknowledgement

This master thesis has been an experience from start to finish. When starting this thesis I would not have expected what was to come. There were ups and downs during this project, but in the end, I am proud of the result. However, I would not have been able to finish this thesis without the help of the people around me.

First and foremost, I would like to thank Marie-Jose for this exciting and challenging assignment. Which seemed like a "simple" problem at the start, but turned out more complex in every stage of the process. I enjoyed your enthusiasm and openness during this project. The times we met to discuss the project always resulted in more ideas and input. You always had interesting feedback and suggestions. I hope this thesis will be the start of the solution.

Secondly, I would like to thank my graduation team Iemkje and Caroline. Your guidance and support helped me to stay critical about my work. The meetings and deadlines in between helped me to stay on track and not fall behind on my planning. I would also like to thank Marian for helping me brainstorm ideas. Your expertise in toilets helped me in figuring out the possibilities within this project. Your enthusiasm and ideas were very motivating. Also, Masha, who helped me with the prototyping process. And made it possible to build my prototype in a time where everything was "closed". I would like to thank the people of Lewis Seating Systems for the interesting workshop and help you provided.

And lastly, I would like to thank my friends and family, who would always listen during both ups and downs. Who believed in me and encouraged me. Which might seem small, but certainly helped.

Jorinde Smits,  
Dordecht, april 2020

# III Summery

## The LooWee

This IPD (Integrated Product Design) master thesis describes the development of the LooWee. The LooWee was developed in collaboration with Marie-Jose, an electric wheelchair user in search for a new toileting solution for female wheelchair users. The goal of this thesis was the further research the idea and design a new toileting solution that could replace the available tools. Currently, adult diapers or a catheter are the only options, but these are medically unnecessary. The two main issues with these tools are discomfort and capacity. They are either painful or won't last the whole day. Limiting the user's mobility and having a negative effect on their quality of life.

Based on previous prototypes and the client experience, this thesis focussed on finding the most suitable design direction. Incorporating a tool into the wheelchair seat would fit most in the given context. However, it came with multiple challenges. The client sits on an orthosis and making alterations can influence the performance of the seat. Which was a problem that occurred in the previous prototype. Therefore the chosen concept focused on incorporating a urination tool without making large changes to the orthosis. Figure 1 shows only one small change is made to the bottom layer of the seat. Which is the ergonomic shape of the seat, which determines its performance.

The embodiment of the chosen concept focussed on comfort and functionality. The different aspects of the concept were further researched. Prototyping and material testing were used to detail the design. In the end, all the results were gathered into the final design, as it is shown in Figure 1. The LooWee can be added to a Lewis orthosis. This seat has a tilted orientation, which is used by the LooWee to drain the urine to the back of the seat. A silicone product is sunken into the seat, to keep it leveled with the top of the seat. A curved shape sticks out from the seat surface with the opening. This curve will form to the user's body and capture the urine directly at the source. Urination through the opening will help control the unpredictable female urine stream and prevent spilling. A toplayer will cover the silicone part, for comfort (mask the feeling of sitting on an opening) and to prevent sweat. The drained urine is stored at the back of the wheel, provides enough room to store the urine of a whole day.

The embodied design was validated with a comfort and functionality test. The main conclusion was that the concept principle works, but the toplayer causes problems. The silicone shape needs further development to create more comfort and be suitable for a long duration of use. A redesign of the toplayer is needed to solve the occurring problems. But overall, the LooWee has the potential to become an alternative toileting solution for female wheelchair users.

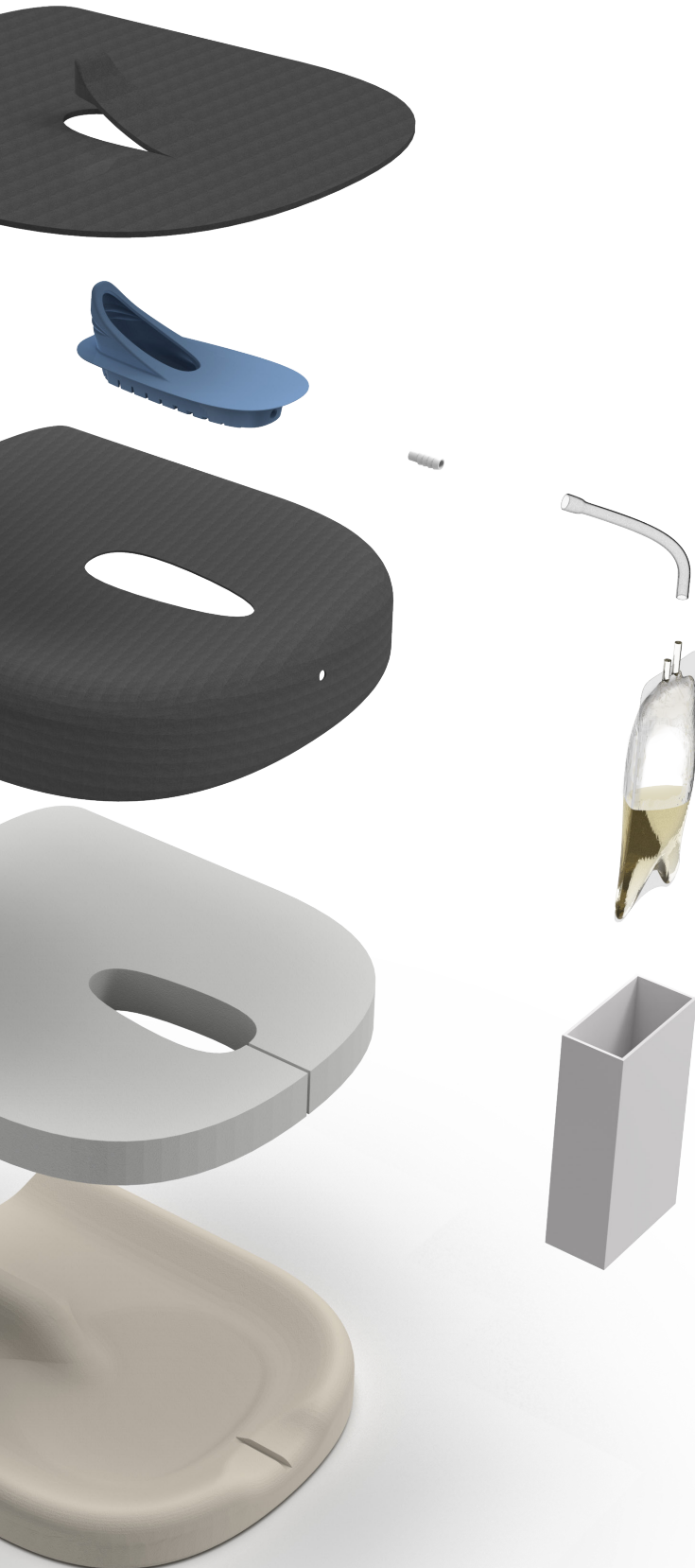

# IV Table of Contents

<b>I</b>	<b>Contact information</b>	<b>3</b>
<b>II</b>	<b>Acknowledgement</b>	<b>4</b>
<b>III</b>	<b>Summery</b>	<b>5</b>
<b>IV</b>	<b>Table of Contents</b>	<b>6</b>
<b>V</b>	<b>Introduction</b>	<b>8</b>

## **1 Analysis**

1.1	The context	12
1.2	The stakeholders	24
1.3	Conclusion	31

## **2 Ideation**

2.1	Design directions	34
2.2	Ideation	35
2.3	Conceptualization	39
2.4	Conclusion	43

## **3 Embodiment**

3.1	Product comfort	48
3.2	Product functioning	56
3.3	Product usage and care	58
3.4	Conclusion	60

## **4 Evaluation**

4.1	Prototype	66
4.2	Method	68
4.3	Results + Conclusion	69

## **5 Conclusion** **70**

## **6 Recommendations** **71**

## **7 References** **72**

## **8 Image references** **74**

## Appendix

<b>Appendix 1</b>	<i>Project brief</i>	76
<b>Appendix 2</b>	<i>Uncommon products</i>	83
<b>Appendix 3</b>	<i>Diaper functionality</i>	84
<b>Appendix 4</b>	<i>User acceptance of the need for a product</i>	85
<b>Appendix 5</b>	<i>Caregivers inspection and quality standards</i>	87
<b>Appendix 6</b>	<i>Ideation - Morphologic chart</i>	88
<b>Appendix 7</b>	<i>Material testing</i>	95
<b>Appendix 8</b>	<i>The lewis Orthosis</i>	99
<b>Appendix 9</b>	<i>Durometer conversion chart</i>	100
<b>Appendix 10</b>	<i>Silicone flexibility and softness test</i>	101
<b>Appendix 11</b>	<i>Scanning methods</i>	103
<b>Appendix 12</b>	<i>Urinal devices duration test</i>	104
<b>Appendix 13</b>	<i>Drainage test</i>	109
<b>Appendix 14</b>	<i>Concept evaluation test</i>	110

# V Introduction

## What is the problem

Urination is something we all do every day without much thought. However, urination is not a thoughtless act for everyone. For female electric wheelchair users, going to the toilet is not a simple task, because most do not have enough strength to make the transfer to the toilet. They become reliant on tools or other people to help them with this “simple” task, but the available tools are limited. “Many are having catheters fitted just to be able to leave the house” (Ryan, 2018). While the alternative is wearing a diaper. Both are medical solutions for problems the users do not have, like incontinence, therefore these solutions are medically unnecessary. In addition, these solutions also have multiple drawbacks. They are uncomfortable and too painful in some cases; they are limiting the mobility of the user; they harm the quality of life.

So imagine, having a catheter which requires you to start taking pain medication, therefore switching to diapers became a better solution. But diapers are not designed for wearing in a continuous sitting position. Together with the accumulation of fluids, this causes pressure injuries. To change a diaper, which must happen every 3 to 4 hours, you need to leave your wheelchair making you very dependent on a caregiver. You can imagine that spending a day outside of your house in this context would be very difficult. This is the problem the client is facing daily and she is not alone. The need for a more suitable solution resulted in the search for a new product. The starting point was to incorporate the toilet solution into the wheelchair seat. Together with Lewis Seating Systems and a hackathon, multiple prototypes were made and tested. This thesis will further build upon the gained knowledge from these previous prototypes.

## Design brief

This thesis builds upon the previously done research and tests, intending to design a new toileting solution for female electric wheelchair users that are no longer able to make the transfer to the toilet. The target group of this assignment might be small, but the impact of the solution on their quality of life will be of great value. The new solution should eliminate the discomforts of the current solutions, but also improve their independence, mobility and quality of life. The user should be able to use the product independently and adequately to their abilities without needing to leave their wheelchair during the day. However, the caregiver can install the product. The most important properties to be addressed are the comfort of the solution as well as hygiene. The product should not reduce the seating comfort or change the shape of the seat surface. The full design brief can be found in appendix 1.

## Assignment scope

The act of urinating, while seated in an electric wheelchair, is the context of this thesis. This is visualized in Figure 2. This assignment solely focuses on urination during the day and excludes menstruation and defecation. The product is the connecting factor that makes it possible for the user to urinate in the wheelchair. But, the product influences aspects of the wheelchair or a person's urination behavior. At home, the toilet provisions are different than in public toilets. The toilet facilities available determines the ease of use of a product.

There are four stakeholders in this assignment. The target group is adult female electric wheelchair users. Therefore, there is no focus on a specific condition. But it will focus on the abilities of electric wheelchair users. The user performs the act and is therefore connected to the context. While the other three stakeholders only come in contact with parts of the context through the user. The caregiver will be the second user of the product and will have requirements regarding the installment and hygiene of the product. The manufactures wishes are taken into account through the product requirements. This focus will be on the use and comfort of the solution, therefore ergo therapists are excluded from the research.

## Approach

This 100-day design project is divided into four phases; the analysis, the ideation, the embodiment and the evaluation. The analysis will explore the context and stakeholders (the scope) to get a better understanding of what the product should do in order to solve the problem. Literature research will be used together with the experiences of the client to gather this information. The resulting design challenge and list of requirements are used as inspiration and reflection during the ideation phase. The chosen concept will be further detailed into a working prototype to test and evaluate the proof of concept. The evaluation will lead to the conclusion of this thesis and possible product recommendations. At the beginning of each chapter, a more detailed description is given of the approach of that phase.



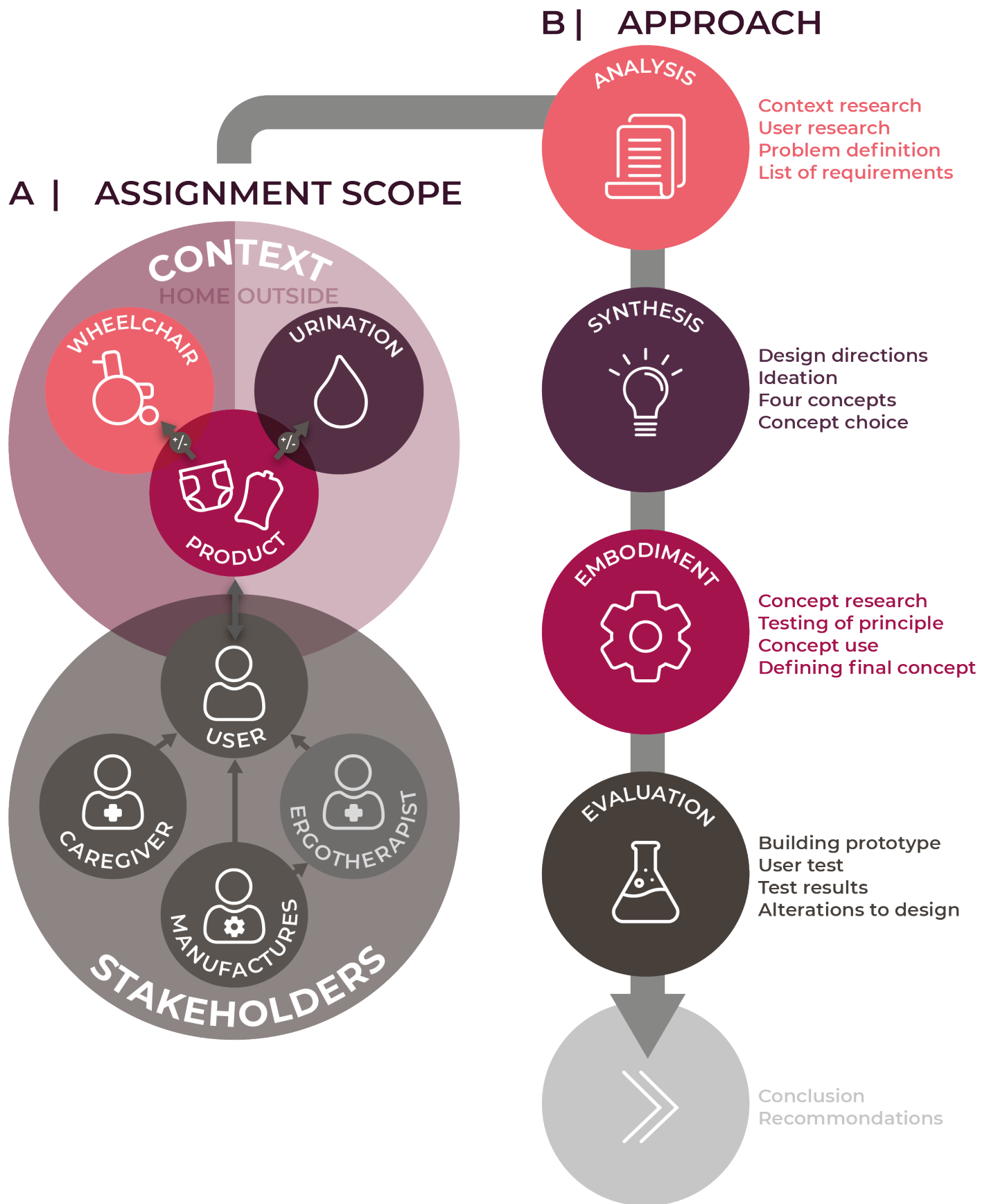

**Figure 2** Visualization of the assignment scope (A) and the assignment approach (B).



# Analysis

The analysis is divided into two parts: the context and the stakeholders. The context of the assignment is urinating, while seated in an electric wheelchair. To make this possible the user needs a product or tool to facilitate this action. Therefore the context can be split into three topics: the wheelchair, urination and the product. The topics will be explored through literature research. All three parts will first be explored separately, only to connect how they influence each other afterwards. The needs and wishes of the stakeholders are explored, by interviews, literature, and forums. The user's abilities and their experience with the currently available solutions will result in product requirements for the product that is to be designed. At the end of this chapter, all these insights will be gathered into a problem definition that will be tackled in the ideation phase. The list of requirements will be used as a means to evaluate concepts further in this assignment.

## 1.1 The context

### 1.1.1 The wheelchair

The wheelchair enabled users to move around, giving them the **mobility** to go places. While doing so, the chair needs to be **comfortable** because users sit in the chair the whole day. The chair also becomes part of the users' **identity** because they are always seen together. These three main functions will be explored in this chapter. But besides those obvious functions, the wheelchair also has features, depending on the user needs and what type of wheelchair is chosen. Most electric wheelchairs come with a standard seat, which is quite flat in shape and therefore in this thesis referred to as a flat seat. Electric wheelchair seats are adjustable, they can rise, tilt or even move the user into a standing or lying position (see Figure 3). The client expressed that the seating height is important because the lower you can go the higher the change of fitting under a regular table.

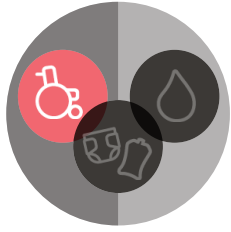

Figure 3 Electric wheelchair in different positions.

#### MOBILITY

Mobility is the most obvious function the wheelchair provides for the user. The electric-powered wheelchair gives the user the freedom to independently go places, through controlling their wheelchair with the use of a joystick or a chin control. However, comparing it to other means of transportation, people in a wheelchair have a similar travel time but a considerably shorter travel distance (Molnár, 2002). Figure 4 shows the difference between regular transport and that of wheelchair users.

But a wheelchair is more than just a means to move around. Mobility is crucial to participate in everyday activities, and in return, these activities can influence health. When these activities are associated with a sense of purpose and belonging they could even be health-promoting (Stenberg et al., 2014). However, research showed that powered wheelchair users did not perceive an improvement in their health-state after the provision of the powered wheelchair (Davies et al., 2003). They did, however, experience improved in their perception of: mobility, pain-reduction, comfort, and Quality of Life. For many users, the duration of time spent outside of the home is influenced by their toilet solution and the public restroom facilities (Ryan, 2018). Spending the day out or going on a holiday is a struggle because of the lack of appropriate disabled toilets. Some wheelchair users hardly go outside for long periods of time, especially not without assistance.

#### A | AVERAGE TRAVEL DISTANCE

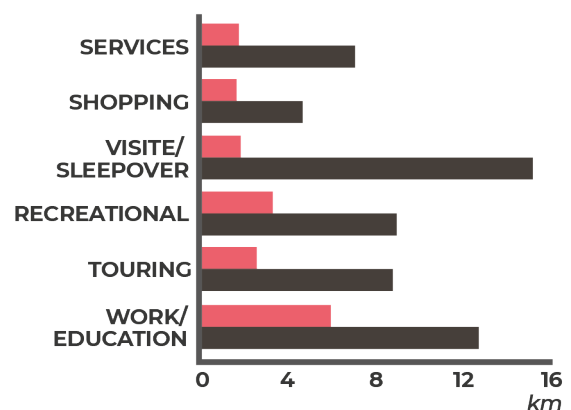

#### B | AVERAGE TRAVEL DURATION

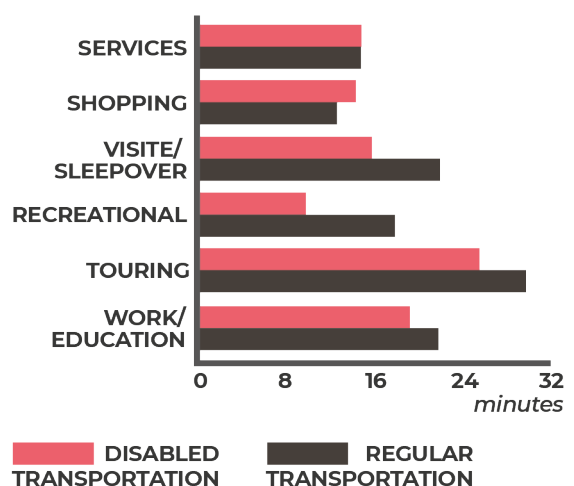
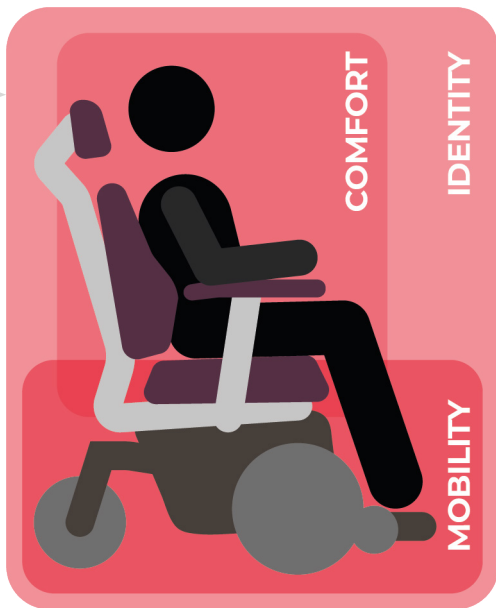

Figure 4 Travel distance and duration for disabled and regular transportation (Molnár, 2002).



## COMFORT

Users spend the whole day in their wheelchair in a static posture, meaning they are often unable to reposition themselves or change positions. Therefore the seat and backrest should provide good support and comfort throughout the day. However, comfort is difficult to measure. It's often described as the absence of discomfort. Vink and Hallbeck proposed a comfort model based on multiple papers concerning product comfort (Vink & Hallbeck, 2012). The resulting model can be seen in Figure 5. When applying this model to the target group it shows an issue concerning comfort. The model explains that when the discomfort is too high the user will use a feedback loop, meaning they will change the environment to improve their comfort. For seating comfort, this will most likely be shifting or repositioning in the seat. For an powered wheelchair user this is difficult or impossible, due to limited body functions. Another feedback could be to change the product. For example, if the user is wearing a diaper, a full diaper can become uncomfortable. Changing the full diaper for a clean one improves comfort. When designing a new product solution, the feedback loop should be taken into account. It would be beneficial if the user could perform the feedback loop themselves, without needing assistance.

## IDENTITY

The wheelchair will become part of the user's identity because they are always seen together. The integration of the wheelchair into the user's life consists of multiple stages and aspects. The integration can be divided into three stages: initial resistance, acceptance, and integration (Stenberg et al., 2014). One of the aspects of integration is to incorporate the electric wheelchair into one's self-identity. Wheelchair users can experience some initial resistance after the provision of the electric powered wheelchair, which could be related to not accepting their progression or because the powered wheelchair is seen as symbol of being severely disabled. But by using the wheelchair users start to experience the benefits. Users that integrated their wheelchair as an extension of their body are most concerned with its appearance, because it is part of their personality (Stenberg et al., 2014).

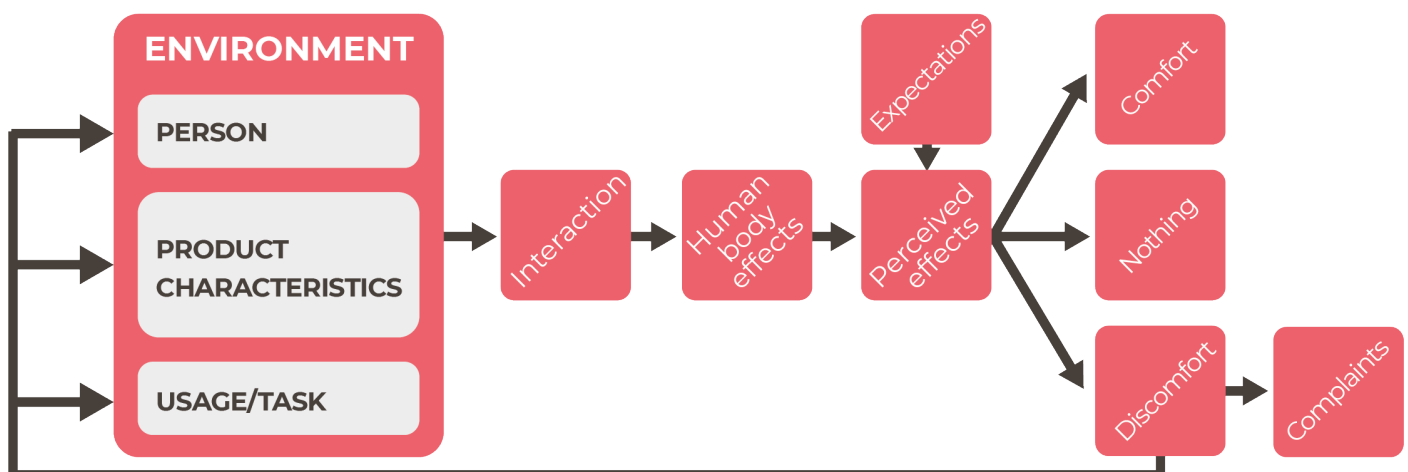

**Figure 5** Travel distance and duration for disabled and regular transportation (Molnár, 2002).

### The cause of discomfort

The main cause of discomfort is pressure injuries, which is a common problem amongst wheelchair users. They are caused by prolonged high-pressure on small areas, which damages the skin and underlying tissue. In a sitting position these high-pressure points are located at the sitting bones, tailbone, spine and shoulder blades (Doorligwond (decubitus), n.d.) (see Figure 6 A). Another cause for these injuries is the sheer force on the legs as a result of bad positioning. When seated, the backrest will exert a load on the back of the user, which is balanced out by the force on the seating area (Hoppenbrouwer, 2019). However, when the seating pan is horizontal this will cause friction and push or slide the user out of the chair. Changing the angle of the seat pan will help relieve the sheer pressure on the legs, as can be seen in Figure 6 B-C (Doorligwond (decubitus), n.d.).

### The solutions for discomfort

Small high-pressure points are common with the regular “flat” seat on wheelchairs. To prevent pressure sores, the critical areas need to be offloaded by means of spreading the pressure over a larger area instead of the small areas (see Figure 6 D) (Endsjo, 2018). Multiple products exist that help to offload high-pressure areas. They can be divided into two categories: a seat orthosis (custom) or a pillow (standard). The pillow is a fast and easy way is to add comfort to a flat seat, but it is not always successful. In addition, seat height also increases which is not desirable. This solution is mostly used for manual wheelchairs and are available in multiple types: air pillows, gel/foam pillows, and silicone honeycomb structures pillows (see Figure 6 E). The seat and/or back orthosis is a custom solution. The client has a seat orthosis from Lewis Seating Systems. The Lewis orthosis applies three important principles in their design:

## The 3 design principles of the Lewis seating system

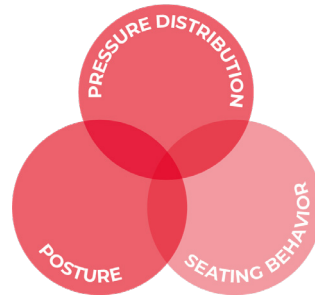

# 1

### POSTURE

Having a functional seat angle between 12 and 20 degrees, to create torso stability (see Figure 6 C). In torso stability, the head will be in balance on the torso creating a seating position that requires the least amount of muscle strength (Hoppenbrouwer, 2019). For good support at the back of a seated person, the support is given at the lumbar area of the spine. This area of the spine is quite similar for each person. An open space between the backrest and seat gives room for the individual curvature of the person.

# 2

### PRESSURE DISTRIBUTION

To relieve the pressure in the critical area, the seat orthosis increases the pressure in the uncritical areas. Critical areas are the sitting bones and tailbone and the uncritical area is the remaining leg surface touching the seat (see Figure 6 A+D). This is achieved by following the form of the human body closely, to prevent unwanted movement. This principle positively affects comfort during long-term static sitting (Vink & Hallbeck, 2012).

# 3

### SEATING BEHAVIOR

Seating behavior is the most difficult principle to achieve because it often requires unlearning wrong behavior, which takes time (Hoppenbrouwer, 2019). Unlearning wrong behavior needs to come for the user him/herself.

**A | CRITICAL AREAS IN SITTING POSITION**

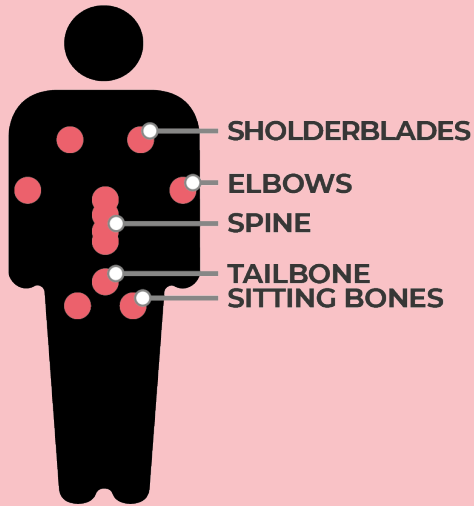

**B | UNSTABLE SEATING POSTURE CAUSES EXTRA FRICTION**

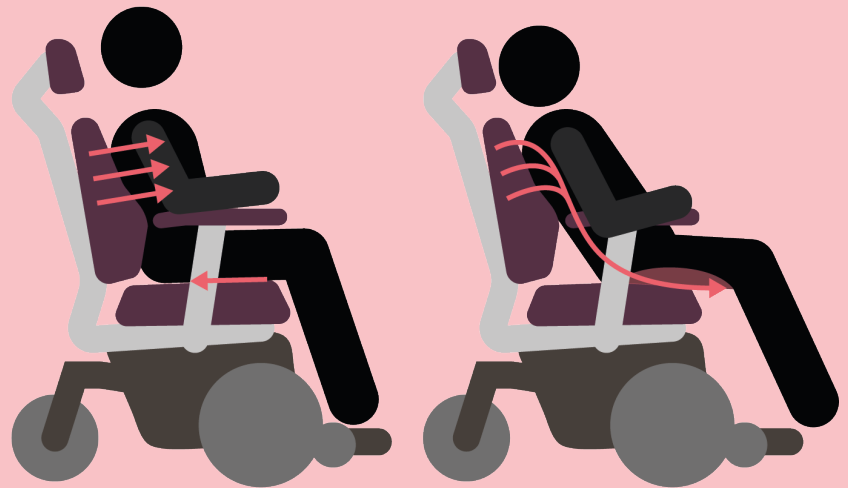

**C | STABLE POSTURE**

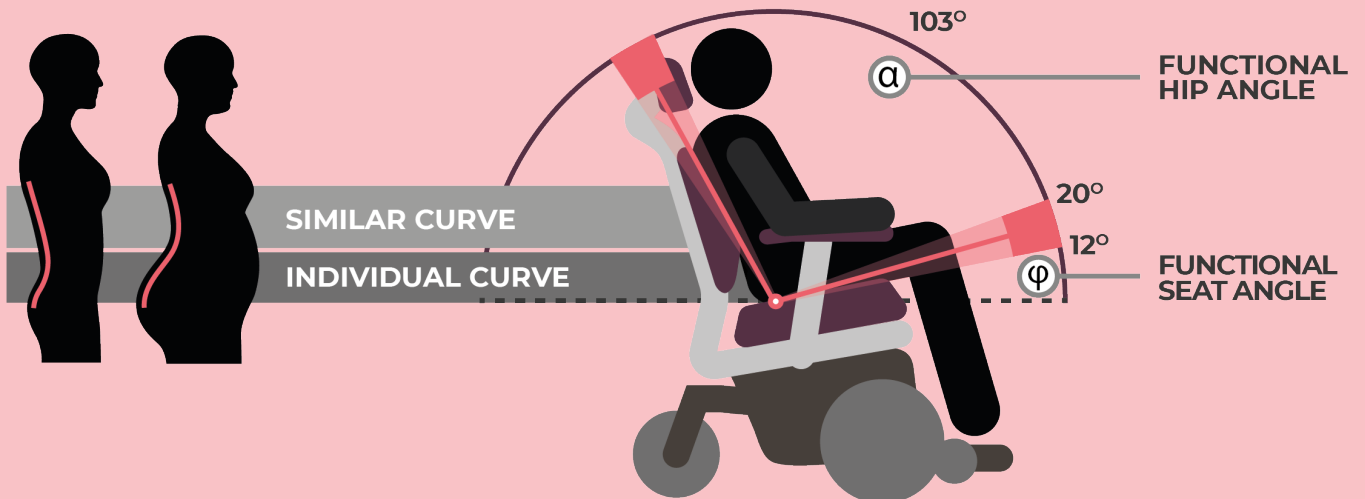

**D | OFFLOADING PRESSURE DISTRIBUTION**

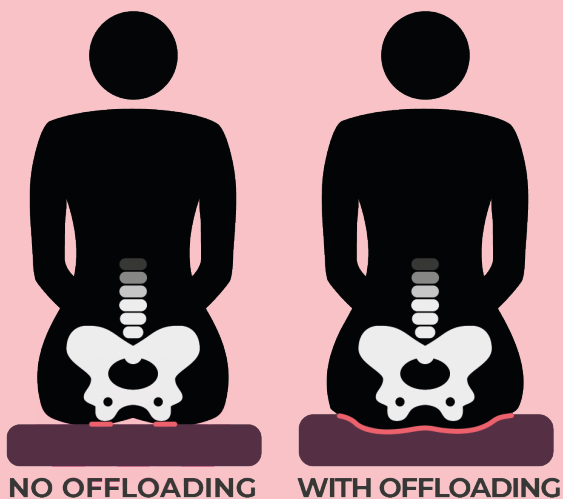

**E | OFFLOADING PRESSURE PILLOWS**

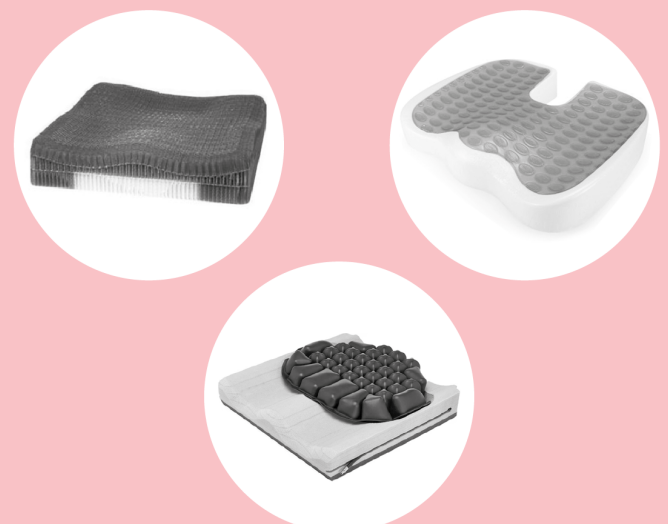

**Figure 6** Overview of the causes and solutions for seating comfort. (Maasstadziekenhuis, n.d.; Endsjo, 2018; Hoppenbrouwer, 2019)

### 1.1.2 Female urination

Urination between females and females in a wheelchair does not differ much from each other. The main difference is the location of urination. Electric powered wheelchair users are not able to make the transfer to the toilet, because they have not enough upper body strength to do so. But, just like other females, they do have control over their urination voiding, meaning they are not incontinent.

#### VOLUME AND SPEED

The frequency and volume of urine is dependent on age and gender (Wein, 2004). Figure 8 shows the means of frequency (a), volume (b) and the 24h urine production (c). On average a female produces between 1,8 liters of urine per day (avg. + std. dev = max. value 2 liters), with a voiding frequency of 7 to 8 times per day and voiding volume of 260 to 300 ml. The amount of urine flow per second is called uroflowmetry, which follows a bell-shaped curve as shown in Figure 7 (Pessoa & Kim, 2018). A healthy female urine flow will follow this curve, with a maximum flow rate between 20 and 36 mL/s.

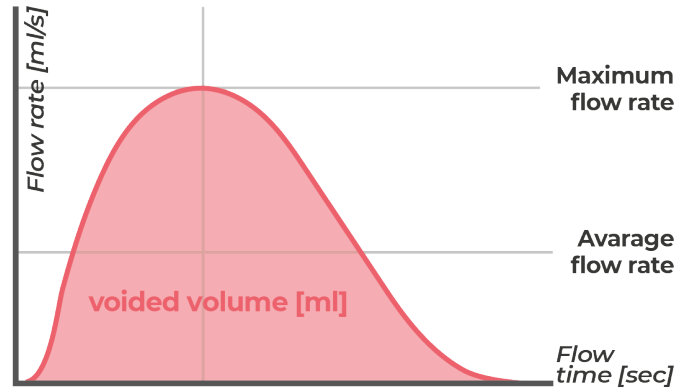
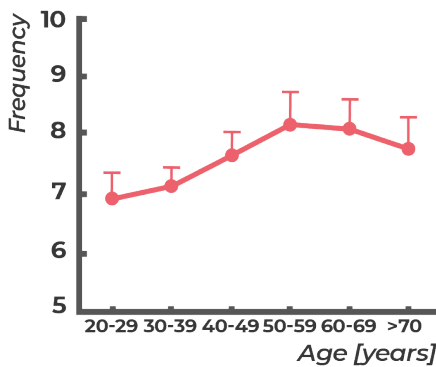
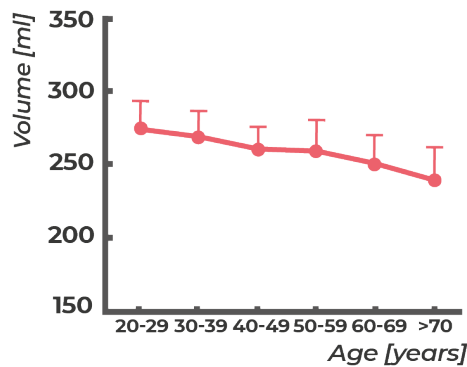

Figure 7 Urine flow curve (Pessoa & Kim, 2018).

#### A | FREQUENCY



#### B | VOLUME



#### C | 24-H URINE PRODUCTION

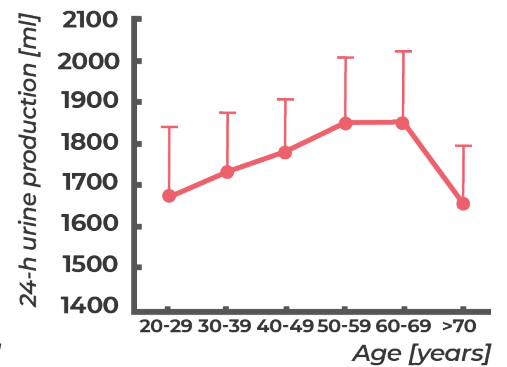

Figure 8 Overview of urinations specifications for different age groups, a) urine frequency b) urine volume c) 24 hour urine production (Wein, 2004).

#### STREAM

When it comes to the difference between male and female urination, the biggest difference is that men have the ability to aim. According to both expert and client, the urine stream of a female is unpredictable and can change depending on the position and angle of the hips (Loth, personal communication, 2019). The position and angle of the hips in a static sitting position (in a wheelchair), can differ based on the type of seat used and the angle of the seat. Therefore, it will be difficult to predict where the urine stream of a wheelchair user will land on the seat.

#### BEHAVIOR

When designing a urination product the use of it must be natural. If not there is a chance that it can change the bladder behavior (Loth, personal communication, 2019). Unhealthy bladder behavior, like premature voiding or holding in urine, doesn't have consequences when you do so now and then. However, doing it regularly can cause infections or even bladder stretching and kidney stones (Johnson, 2018).



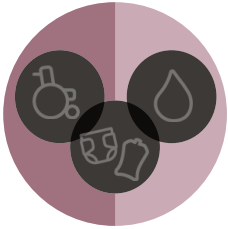

### 1.1.3 Urination environment

The environment of the context can be split into two parts: home and outside. Because users are not capable of making a transfer they don't necessarily require a bathroom to urinate. Both catheter and diaper make it possible to urinate without having to go to an actual toilet. Unless the product needs to be emptied or changed, which requires privacy as well as the possible facilities to enable the product change.

#### HOME / OUTSIDE

At home, users have the right facilities to meet their needs, think of an adapted bathroom and a lifter. But as soon as a user goes outside the facilities become inadequate ("Openbare toiletten ramp", 2015; Bubbert, 2018). Even though public disabled restrooms have to meet certain regulations, they are still too small. In a research

into the accessibility of public disabled restrooms in 2014 the Dutch restrooms only scored a 3.7 (an assessment of 175 disabled toilets) ("66 procent van mindervalidentoiletten", 2014). This research produced some shocking numbers, as can be seen in Figure 9:

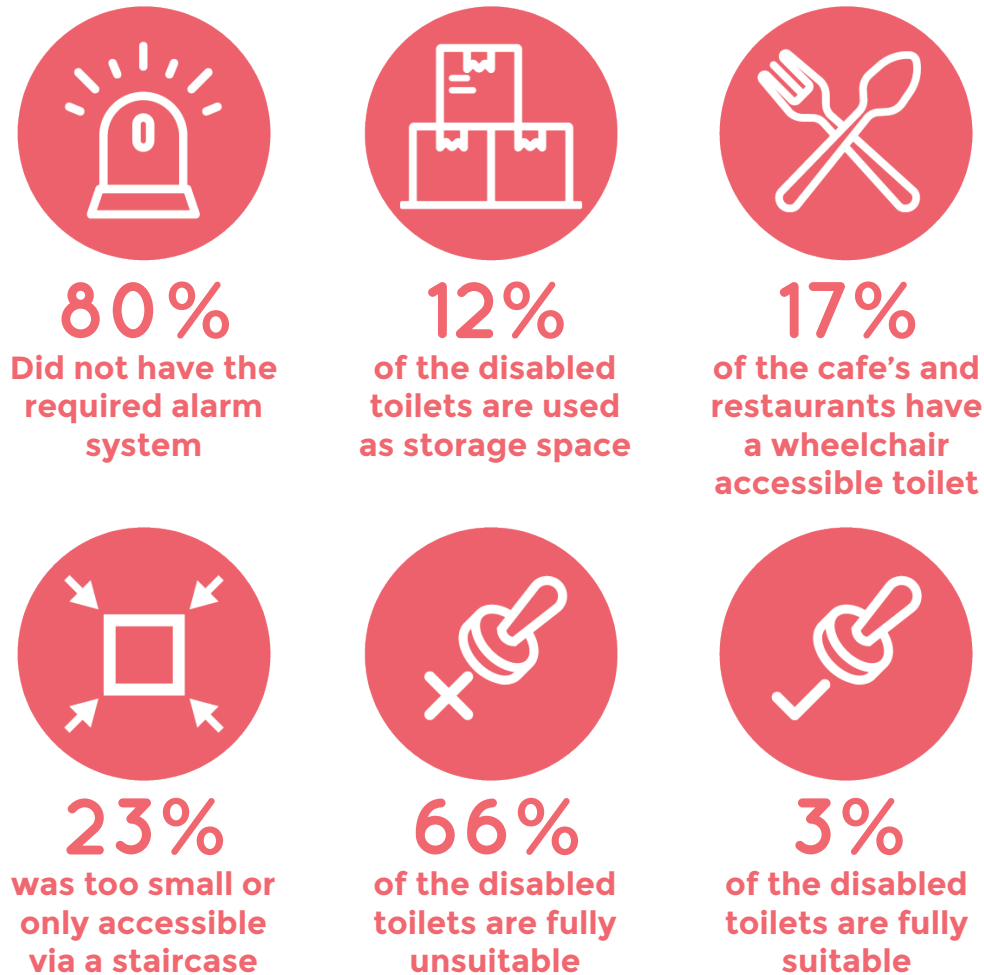

**Figure 9** The results from an assessment of 175 public disabled toilets in the Netherlands.

### 1.1.4 Urination for an electric-powered wheelchair users

There are four main urination tools available for female wheelchair users: caregivers, urination tools, adult diapers or a bladder catheter (Figure 10). But there are also other uncommon products available, which will not be discussed in this chapter but can be found in Appendix 2. Because caregivers are not always present and urination tools require upper body strength, these two options are considered unsuitable solutions. That leaves the adult diaper and the catheter, which will be researched in this chapter. In addition, the two prototypes made and tested by the client will also be explained. The product is the connection between the wheelchair and urination, therefore the way the product influences different aspects of the context will be discussed. The different aspects of the context that can be influenced are indicated in Figure 12 (next page) with the numbers one to eight. In the text, references to these numbers are made to indicate their relation to the context.

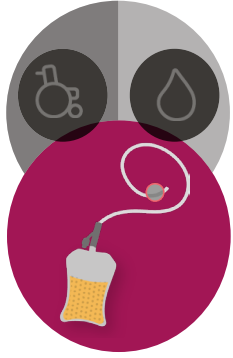

Figure 10 Available urination tools.



Figure 11 A suprapubic catheter

#### BLADDER CATHETER

The bladder catheter is the more intrusive option. There are two ways to insert the tube into the bladder: through the urethra or through a surgically made incision below the navel (suprapubic) (Suprapubic Catheter, n.d.). Because users spend most of their time sitting in their wheelchair, often a suprapubic catheter is chosen because it's easier to take care of (Jewell, 2019). The catheter is directly connected to the bladder and does not affect the urination behavior of the user **5 + 6**. The tube needs to be replaced every 1 to 4 weeks, which can be done by a nurse.

The catheter consists of two parts: a tube and a drainage bag. The inflatable balloon tip of the tube will hold it in place (see Figure 11). A bladder catheter is mostly a solution for an injury to the urethra, bladder weakness, nerve damage or birth defects affecting the urinary tract (Bladder & Bowel Community, n.d.). However, for female wheelchair users, it is medically unnecessary but chosen over diapers due to the freedom it provides. It allows them to leave the house for longer periods **1** (Ryan, 2018). The drainage bag comes in different volume sizes to meet the users' needs **4**.

It is easy to empty and clean and therefore easy to manage by themselves (with sufficient upper body strength) or a caretaker **8**. However, it does tend to leak and cause a smell **3**. However, for some people the downsides outweigh the benefits. The main downsides being the high risk of infections and pain and/or discomfort **2**. Some people respond badly to a catheter, which sometimes even leads them to take medication for the pain **7**. Not to mention the long-term effects of catheter use, therefore it should only be used when absolutely necessary (Berry, 2017). Long-term complications include kidney inflammation and kidney or bladder stones.



## DIAPER LAYERS

Topsheet

Surge layer

Absorbent core

Outside layer

Figure 13 The 4 layers of an diaper

### ADULT DIAPER

An adult diaper is a product that is used for people with incontinence. A diaper can store a certain amount of urine, depending on the capacity. A diaper consist of four layers: a topsheet, surge layer, absorbent core, and an outside layer (see Figure 13). All these layers have a specific function (Hammack, 2016), which can be found in Appendix 3.

The downside of adult diapers is the way they are designed to be worn. The underwear shape works for people who can move around and change between sitting and walking. However, they are unsuitable for continuous and static sitting. The client experienced discomfort and pressure injuries at the abdomen from wearing the diaper **2**. The advantage of a wearable is that the urine is captured directly at the urethra, making the urine stream very short to prevent spread **6**. There is no knowledge about the influence of adult diapers on the urination behavior of users without incontinence **5**.

Another downside is the diaper's capacity, even an XXL needs to be replaced after 3-4 hours **1+4**. For the replacement of the diaper, the user is dependent on a caregiver to help them **7**. Asking a caregiver to change the diaper is by some user seen as embarrassing **3+8** (Ryan, 2018). To change a diaper the user needs to lie down. Public restrooms don't have adequate facilities to lay down and there is not enough room for the electric wheelchair to be placed next to the toilet (to move the user from the wheelchair to the toilet). Therefore, changing a diaper would require two caregivers: one holding the user up and the other changing the diaper. This makes it difficult to leave the house for longer periods.

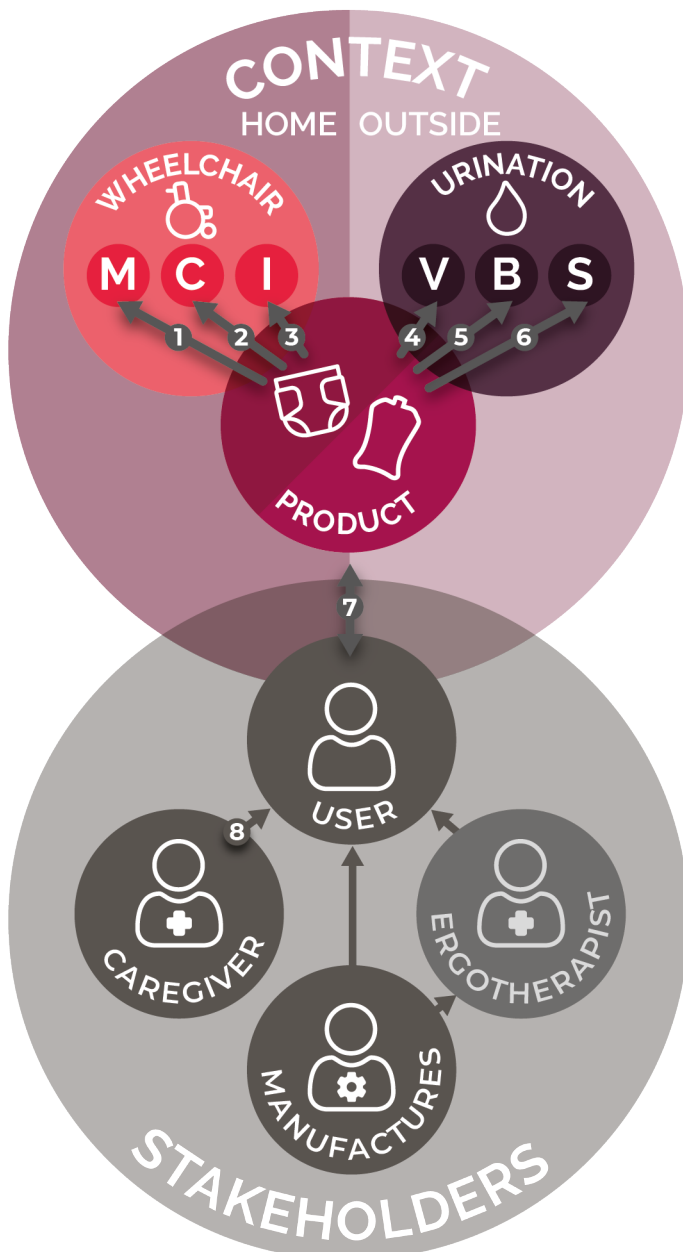

Figure 12 Areas of influence of the product on the context.

THE CLIENT'S PROTOTYPES

Both previously described options resulted in pain and discomfort for the client, therefore the client decided to explore more suitable alternatives. Two ideas were made and tested. The first is a seat with a hole made into it and a storage compartment

underneath. In a second iteration, this hole was filled with open-cell foam. The second idea tested is an altered diaper that is laid flat on the seat. The client's experience of these three prototypes will be explored below, with emphasis on the positive and negative aspects of the prototypes..

1A Hole in the seat

The already used Lewis seating orthosis was altered, making a hole in it. In the small space under the seat a container was added, where the urine was stored. The container has a lid that can slide open during urination and afterward closed to keep the smell inside (Figure 14+Figure 15). The lid handle is positioned at the front of the seat between the legs, which she could reach because she still has enough upper body strength to do so.

1B Hole in the seat filled with foam

This prototype is an iteration on the first prototype. The hole is filled with a water-repelling open-cell foam, through which the urine can flow. It also provides support to the human body. The container is changed into a drawer with a diaper placed into it. Diapers turn urine into gel and prevent smell, therefore the drawer doesn't need a lid.

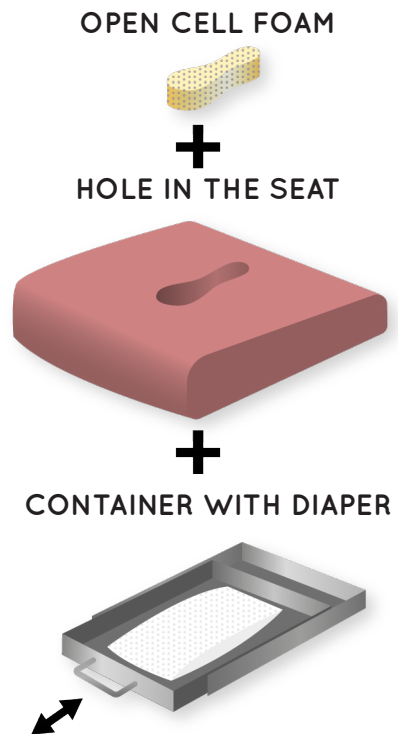
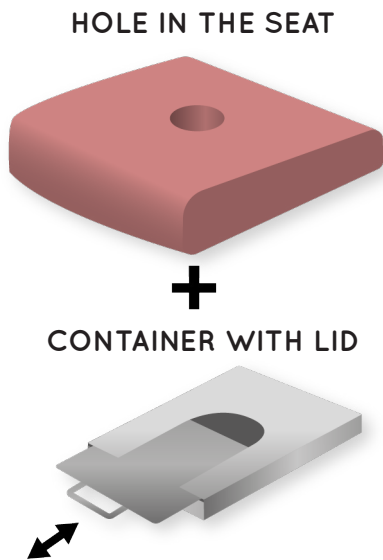

No need to leave the wheelchair when emptying the container.  
Because the urine is stored as liquid, this concept creates no waste.

Storing the urine in a diaper enables the client replace the diaper independently, because it can be reached and emptied without leaving the wheelchair,

The diaper will store the urine and prevent smell.  
The shape of the hole (more oval) was an improvement in terms of position and size.

After days of use, the hole started to become painful because part of the body was hanging in the hole without support. Not suitable for long-term use.  
Storing the urine as a liquid can smell and create a mess when disposing.  
Because of the unpredictability of the urine stream, the seat can become wet.

The rough foam was uncomfortable and irritated the skin. Not suitable for long-term use.  
The edges between the seat and foam were not smooth and therefore uncomfortable.  
Because of the unpredictability of the urine stream, the seat can still become wet.  
The memory foam used for the seat doesn't provide enough support.

## 2

### Flat altered diaper on the seat

Instead of wearing the diaper, it is placed flat on the seat. To be able to do so, the diaper needs to be altered. The sides and leg cuffs are cut off and the diaper is flattened as much as possible. To use this independently, the client's clothes are cut open at the backside and she doesn't wear underwear. She sits directly on the diaper.

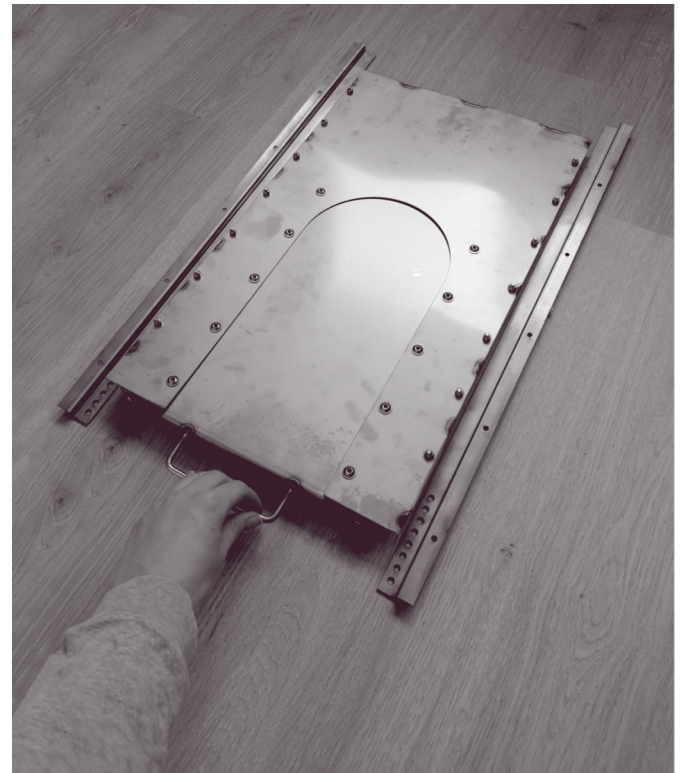
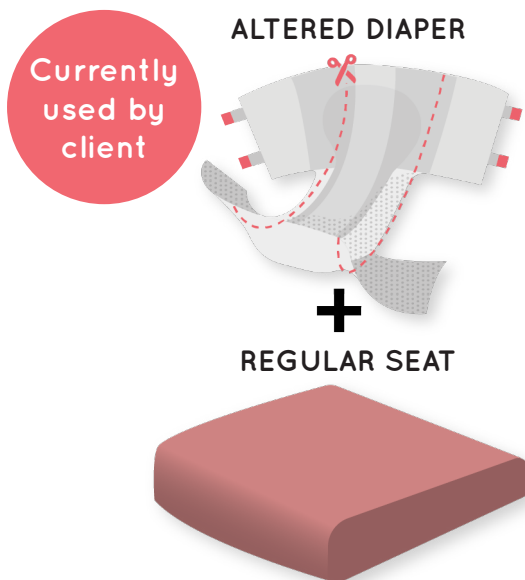

Figure 14 Container of prototype 1A, with the lid closed.



Figure 15 Container of prototype 1A, with the lid open.

In case of an accident (e.g. diarrhea) it can easily be removed and replaced.

No changes are made to the wheelchair seat.

The client's quality of life was improved and is used to date.

It cannot be changed in a public restroom.

Time-consuming alterations to the diaper.

Some shifting around and pulling on the diaper is necessary to get comfortable.

The accumulation of liquids in one place can influence the shape of the seating surface, thereby causing pressure injuries if not replaced on time.

**COMPARISON OF THE FOUR PRODUCTS**

Four urination solutions have been discussed: the catheter, adult diaper and two prototypes. Each solution functions differently in the context, providing certain benefits or disadvantages to the user. A urination tool has six important qualities that determine the user experience: quality of life; comfort; independence; capacity; clean; absence of smell. The four products are evaluated on these six qualities. To rate the 2 prototypes, the client's experience was used. Table 1 shows the scores given to the four concepts. The independence quality is dependent on the amount of upper body function of the user, therefore the values in this column are based on users who still have some upper body strength. The four solutions are compared two each other, using the 6 qualities. The result can be seen in Table 1.

Between the catheter and diaper, the first is the better option. However, the experiences are very dependent on the person and can range from comfortable to painful. A good experience doesn't take away that this procedure is still medically unnecessary. The diaper has too many downsides for this target group to be a suitable solution, as can be seen in Table 1. From the two prototypes, the flat diaper has the highest score. The positive rating on the quality of life means that the client has a good overall experience. The difference in ratings between the wearable and flat diaper shows the influence of the use of a product on the user experience. Apart from the low comfort rating, the altered seat does have advantages in functionality. It improves the independence of the user and has a large enough capacity to last the whole day. For the user, the flat diaper is the best choice, but the table shows that none of the solutions stand out in particular.

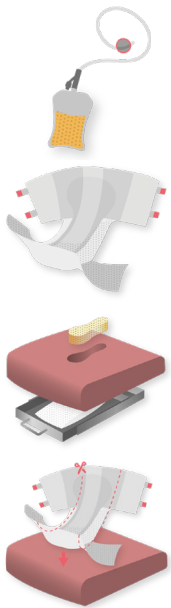

	EXPERIENCE		FUNCTIONALITY		HYGIENIC	
QUALITY OF LIFE	COMFORT	INDEPENDENCE	CAPACITY <small>(duration of use)</small>	CLEAN	ABSENCE OF SMELL	
<i>+/-</i> <i>very different experience per person</i>	<i>-</i> <i>painfull</i>	<i>+/-</i> <i>some users can empty the drainage bag</i>	<i>+</i> <i>volume fit to use needs</i>	<i>+/-</i> <i>possibility of infections</i>	<i>+/-</i> <i>tubing can leak urine and smell</i>	
<i>-</i> <i>pressure injuries</i>	<i>-</i> <i>pressure injuries</i>	<i>-</i> <i>cannot change independently</i>	<i>-</i> <i>4 hours</i>	<i>+* /-</i> <i>(* when changed regularly)</i>	<i>+</i>	
<i>-</i> <i>pressure injuries</i>	<i>-</i> <i>pressure injuries at area of the hole</i>	<i>+</i>	<i>+</i>	<i>+/-</i> <i>urine could land on the seat</i>	<i>-</i> <i>urine could land on the seat</i>	
<i>+</i>	<i>+/-</i> <i>small edges and folds = not comfortable</i>	<i>+/-</i> <i>client can (at home) change independently</i>	<i>-</i> <i>4 hours</i>	<i>+* /-</i> <i>(* when changed regularly)</i>	<i>+</i>	

**Table 1** Comparison between 4 products, of which the first two are mainstream products and the last two are prototype concepts tested by the client. The ratings for the prototypes is the client's experience.



### 1.1.5 Context insights

The product connects the wheelchair and urinating, to make the action possible without needing to make a transfer. But the current products don't always have a positive effect on the qualities the wheelchair provides to the user. Limiting their mobility and comfort, which is enhanced by the poorly accessible public restrooms. Besides the influence the products have on the context, it also influences the user experience and their quality of life. None of the discussed products have a completely positive user experience. The flat diaper scores slightly higher than the catheter. However, the experiences users have with the catheter are very divergent. If a user responds badly to a catheter the only handsfree solution on the market is a diaper, which has the lowest score. The results from the context analysis provide guidelines to be met by a new product:

- » **Mobility** is important for wheelchair users, to participate in daily activities. However, the current solutions limit the duration spend outside of the house. Especially if the product requires changing or replacement during the day. The new solution should positively influence the mobility of the user. To enable them to go places independently for longer periods of time. Therefore the product **capacity** should be able to store 2 liters of urine.
- » **Comfort** is a difficult concept and is often referred to as the absence of discomfort. People can prevent discomfort by changing the environment, but for powered wheelchair users it's difficult to reposition themselves. The new solution should not be uncomfortable when (statically) seated on it.
- » **Identity** The wheelchair is part of the identity of the user. The looks of the product could change the look of the wheelchair, desirably this does not happen negatively. Or it should not even be visible at all.
- » **Urination behavior** can be affected by the way a product is used. Prolonged unhealthy bladder behavior can become harmful and should be prevented.
- » **The female urine stream** is very unpredictable and should be controlled by the product to keep it hygienic and prevent smell and leakage.

## 1.2 The stakeholders

### 1.2.1 The female electric wheelchair user

According to CBS<sup>1</sup>, 6,2% of the Dutch population (between 19 and 65) live with limitations on movement ("Gezondheidsmonitor", 2018). Limitation on movement is a broad understanding of different types of physical conditions that impact a person's ability to move. However, not all of the 6,2% will require an electric-powered wheelchair. There are no clear numbers regarding the total amount of electric-powered wheelchair users in the Netherlands. Some sources suggest that there are around 225.000-250.000 wheelchair users (both manual and powered and male and female) (de Klerk, et. al, 2017). Of this number, approximately 150,000 are permanent wheelchair users. The target group for the assignment is relatively small, but also very specific. This chapter will focus on the users' abilities and how they deal with the need for a urination product. To get a better view of the user experience. This information is gathered from interviews, articles, and forums as well as the experience of the client.



#### WHEELCHAIR USER'S PROFILE

Powered wheelchair users have capabilities and needs. They need assistance in the morning and evening, but they don't require full time-care. Depending on the amount of upper body strength, some users may need more care. To get a clear image of what the user is capable of and needs, three topics will be discussed: capabilities, motivation, and needs:

##### Capabilities

- » Because of their limited (or no) upper body strength, they need assistance to get in and out of the wheelchair. They have access to caretakers, but do not require continuous care.
- » In general, they have normal healthy bladder function, but are unable to transfer to a toilet because of their limited upper body strength.

##### Motivation

- » Users want to go out, which is their motivation to start using products to help with their urination (Ryan, 2018).
- » They want to be independent, but are held back because no well functioning urination products are available.

##### Needs

- » They need a product to facilitate urination while sitting in their wheelchair, but currently there are only medical options available.
- » They have caretakers to help them with certain task, but want to have a toileting solution that they can use without assistance.

#### USER EXPERIENCE WITH URINATION PRODUCTS

The experience female electric powered wheelchair users have with their chosen product is very diverse. When comparing user experiences from sources like forums (Myocafé) and articles, some overlaps were found. Most users have a solution for their urination needs when they are at home (Ryan, 2018). Taking a day trip or working from 9 to 5 present the biggest challenges. There are three steps when it comes to wheelchair users searching for the right urination solution (full description in appendix 4):

##### 1 Postponing assistance

Often users start to regulate and limit their fluid intake and "hold it" when they are not at home. However, this can have consequences like headaches, low energy and even result in incontinence.

##### 2 Accepting the needs for a solution

When limiting fluid intake no longer suffices the user will need to start using a product. These are often the regular options like a catheter or adult diapers.

##### 3 Looking for alternatives

A small group of users will start to look for alternatives to the available products because they do not meet their needs.

Three different types of users can be identified, based on the different ways users came to accept the need for a solution. This was done using segmentation, as shown in Figure 16. The three types of users are: the traditionalist, the researcher and the creator. A user does not by definition belong to only one of the types, but can also be a combination or evolve. Generally, users will start out trying regular products, but it's the response to those products that are different. A traditionalist will accept the downsides as part of it, while the researcher and creator will actively look for an alternative. Most likely the traditionalist will be the hardest to convince trying a new product. The researcher and creator already have tried multiple products and will probably be open to new products. Based on the gathered information the creator group is relatively small.

<sup>1</sup>C.B.S.: Central Bureau of Statistics: a national government agency charged with census and statistical research.



self-directed  
**Active**

*"We have already tried urinal and bedpan, but in a wheelchair that really does not work. I also tried diaper pants, but this caused a lot of irritations ... Does anyone have an idea how I can solve this problem?"*  
(Chantal, 2010)

**Analytic**  
searching

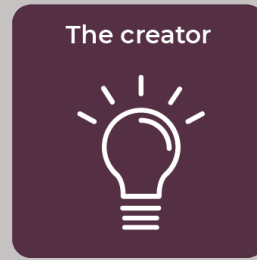

*"Cut the crotch out of your pants so that only the front remains. You do not wear underpants, but sit on a fabric mat in the color of your wheelchair upholstery."*  
(Annet, 2005)

**Creative**  
imagining

*"In itself, this [suprapubic catheter] is excellent, the regular bladder infection is something I make do with."*  
(Leo, 2010)

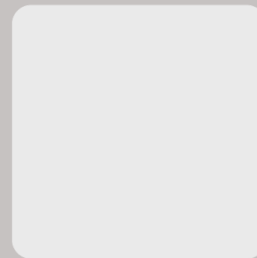

**Passive**  
depending

**Figure 16** The 3 identified users.

**The traditionalist**

Make do with the products available or given by a doctor, even though it might not be completely to their liking. They accept the downside of a solution because it is part of it.

**The researcher**

Trying to find different (existing) alternative solutions, through research and forums (asking others for advice) (Myocafé, 2003). Getting information about how others solve the same problem. They try multiple products to find out what works and whatnot.

**The creator**

Creating their own solution. They have tried multiple solutions, but the existing solutions do not meet their expectations or wishes. Because they have tried a lot, they know their bodies well and thus know what would or would not work.

**WHAT KIND OF PRODUCT WOULD THEY WANT:**

This user will most likely use a product that is given by a doctor or caregiver. Therefore they might not be the first to try a new product, but only after it has been used and proven effective.

This user is likely to try new products when they find it/ hear about it.

This user is most likely to try new products even in a prototype stage. They are open to possible alterations to clothes etc.

**CLIENT EXPERIENCE WITH HER CURRENTLY USED PROTOTYPE**

The client is a good example of a creator. The client currently uses a self-made solution, the flat diaper, which was explained in chapter 1.1.4. To get a better view of the flat diaper and all the steps that are necessary for its functioning a scenario is made together with the client. This scenario, as can be found in Figure 17, describes the 7 steps. Each step explains who is involved and describes what the step entails. After making the scenario this was used to discuss what steps need to change in the future or even be eliminated. The three steps that are highlighted red require change:

**STEP 1 | COMFORT**

*When transferring into the wheelchair, the diaper will slide backward, leaving the uncomfortable folding line under her hips (area most sensitive to pressure injuries). The diaper needs to be pulled forward and some wiggling and shifting are necessary to get comfortable. For the future, it would be desirable to have a product that doesn't shift when sitting on it.*

**STEP 2 | CAPACITY**

*The diaper can last between 4-5 hours (this is can vary per person). For the future, it would be desirable if the product could last the whole day (12h) or can be emptied without leaving the wheelchair seat.*

**STEP 0** Preparation of the diaper **STEP 1** Place diaper on the seat

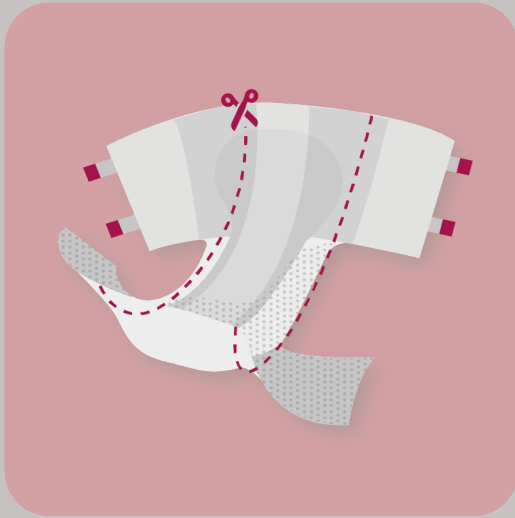

**Involved: caretaker**  
When possible the alterations are done for a large amount. This step is therefore not always needed. The leg cuffs are not fully removable, leaving small edges.



**Involved: caretaker**  
Folding line (RED line) makes only one way of placement possible. The front of the diaper is folded back and not used.



**STEP 4** Use inside / outside



**Involved: user**

**STEP 5** Diaper is full



**Involved: user**  
When the diaper is full its will become uncomfortable. This is a sign that it needs to be changed.

**Figure 17** User scenario for the prototype currently used by the client.

## STEP 2 Transfer into wheelchair

after shower etc.



### Involved: caretaker + user

When the user sits in the chair the diaper will move backwards, moving the folding line (RED dot) underneath the sit bones.

## STEP 3 Getting comfortable

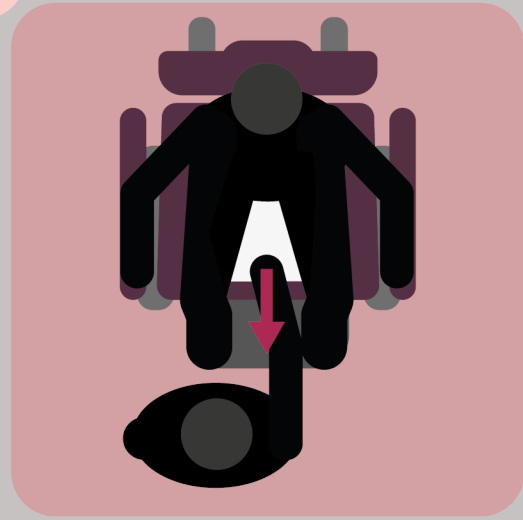

### Involved: caretaker + user

To position the diaper back to the ideal placement, the caregiver will pull the diaper forward. Some wiggling might be necessary to get comfortable.

## STEP 6 Changing diaper

disposed



REPEAT

### Involved: caretaker + user

Caretaker will lift the user out of the chair and repeat steps 1-3. If the user does the change herself, she will use a lift to get out of the chair. She will do the steps herself while facing her wheelchair.

## STEP 7 Transfer out of the chair

END OF DAY



### Involved: caretaker + user

### 1.2.2 The caregiver

The wheelchair user is only one of the two main users of the product. A caregiver will help the wheelchair user to install and dispose of the product, as can be seen in the scenario previously described in chapter 1.2.1. There are two types of caregivers: formal and informal caregivers. A formal caregiver is a healthcare professional and an informal caregiver (mantelzorger) offers care as a (care) volunteer, these are generally family members and friends ("Cijfers meldingen verpleeghuiszorg", 2019). The amount and frequency of help depends on the user. With the ongoing staff shortage in the healthcare sector, time is precious for the caregivers ("Personeelstekort in thuiszorg" 2018). The care they provide needs to meet rules and regulations established by the government, to provide their clients with the proper care. The government has established an assessment framework that the caregiver must meet, which can be found in Appendix 5 (Toezicht op de Zorg Thuis 2.0, 2019).

Urination solutions need care moments during the day, starting with the placement in the morning. Depending on the product, it may need to be replaced during the day, this could be one or multiple extra moments during the day (see Figure 18 a). The two main moments of care are the mornings and evenings. If a product could last the whole day the preparation and disposal of the product would coincide with the morning and evening care moment. Which could be beneficial for both user and caregiver (see Figure 18 b).

Where the user will be most concerned with the use stage of the product (comfort, hygiene, etc.), the caregiver will find the installment and disposal stage most important. The ease of use and understanding of product placement is important. Another benefit of not needing to lift the user out of their chair during the day is that it lowers the change of incidents. Fall and lift incidents were the most common, 57% of the calamities in 2018 ("Cijfers meldingen verpleeghuiszorg", 2019) (see Figure 19). This substantiates why a solution where the user can stay seated is beneficial.



#### A | CURRENT AMOUNT OF CARE MOMENTS

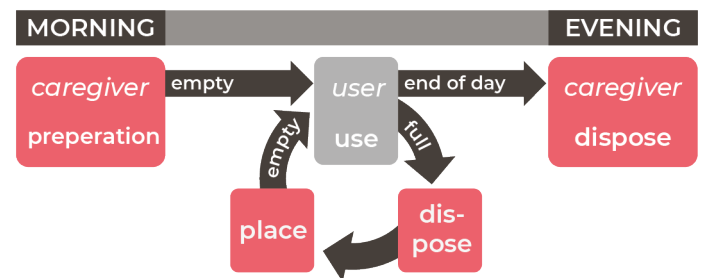

#### B | DESIRABLE AMOUNT OF CARE MOMENTS

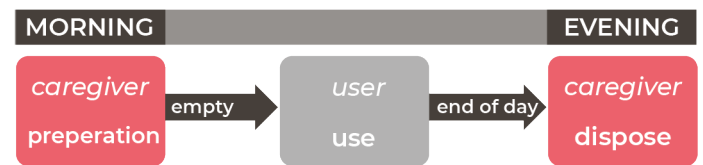

**Figure 18** (A) The current amount of care moments of the caregiver during the day and (B) the desirable amount of care moments of the caregiver during the day.

#### CALAMITIES THEMES IN 2018

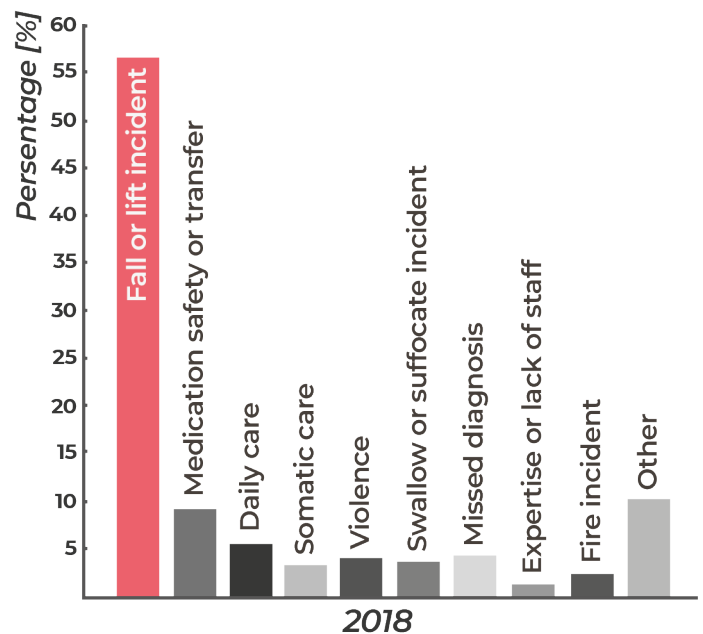

**Figure 19** Calamities in the home care sector in 2018 ("Cijfers meldingen verpleeghuiszorg", 2019).

### 1.2.3 The wheelchair manufacturer

The user and caregiver are the main users of the product. However, the wheelchair and orthosis manufacturers also have an interest in the product if it will contribute to the functionality of their product. The manufacturers have a certain product quality they want to provide for the user. Looking at the brand goals of big wheelchair companies it becomes clear that their goal is to provide mobility and independence with a high focus on customer needs. Many companies realize that every person is unique and focus on a customized solution.



#### PERMOBIL

*“For more than 50 years we have been developing products that positively **impact the mobility** and daily lives of people with disabilities. Our products offer people with disabilities the opportunity to **lead active, independent lives.**”*

(Permobil, n.d.)

#### LEWIS SEATING SYSTEMS

*“Lewis Seating Systems wants to **improve the quality of life** of wheelchair users by providing them with a **free of pain** sitting experience. We do this by sharing our knowledge about sitting and applying the Lewis sitting orthosis.”*

(Wie zijn wij, n.d.)

#### OTTOBOCK

*“For 100 years, it has been our mission to restore or **improve the independence** of people with reduced mobility. Most people know Ottobock as a company that manufactures aids such as prostheses, braces, and orthoses, wheelchairs, buggies. We are proud of our quality and the advanced technology that can be found in our products.”*

(Over Ottobock, n.d.)

Even though the urination tools are separate from the wheelchair, the products can influence or limit the functionality of the wheelchair. Especially if changes need to be made to the chair. When it's a positive effect, think of improving mobility or comfort, it will contribute to the functionality of the wheelchair. If the urination product improves mobility it could also help users fully enjoy the wheelchairs, because their urination needs don't keep them at home. This will align with the visions of wheelchair manufacturers. But, when a product has a negative

effect, like discomfort or limiting the functionality of the wheelchair it could indirectly also influence the experience of the wheelchair itself. For example, a product added under the seat could limit the range of up and down movement of the wheelchair seat. This can be a concern for wheelchair manufacturers because it will lower the quality they aim to provide. There needs to be a good balance between the wishes of the user and what is technically feasible within the context of the wheelchair. A product that adds value or improves the functionality can be of value to the manufacturers.



#### 1.2.4 Stakeholder insights

*The target group for this assignment is small, but the user experiences with the available products are very diverse. How users deal with the fact that they need assistance with their urination is also very different, but three types of users could be identified. The more active users will be more open to new products and trying new things. But over time the traditionalist users could also be reached when the product proves effective. The new product should have the following qualities to fit the users' needs: comfort, independence, and duration of use. For most users being away from home for long periods is the biggest challenge, think of working, day trips or holidays. The only product that can last the whole day is a catheter. Catheters are experienced as painful.*

*The caregivers are the ones installing the product and will clean or dispose of it at the end of the day. For them, it is important that the product is helping the user, is easy and fast in use and is hygienic. For both users and caregivers, it is beneficial if the users don't need to leave the wheelchair during the day, from the viewpoint of safety and time efficiency as well as the independence of the user. The wheelchair and orthosis manufacturers' main concern would be the effect a product has on their product. These companies have the goal to provide independence and mobility to the user, which meets the wishes of the user.*



The analysis provided a lot of insights into the context and the stakeholders, and what areas should be improved. All the results are gathered and translated into a problem definition and a list of requirements. The main focus will be on the user's comfort and product capacity.

### Problem definition

Female powered wheelchair users have limited to no arm function, therefore they cannot make the transfer to the toilet. They need a product to help them urinate while staying seated in their wheelchair but have very limited available options. The existing options are medical solutions that are used to solve non-medical problems. Additional disadvantages of these products are discomfort, the dependency on caregivers, and the limited urine storage (diapers). With limited storage the product will not last the whole day, resulting in multiple care moments during the day to replace the product. This is not a problem when a user is at home with the right facilities. But insufficient public facilities make it difficult to impossible to change a product. Complicating leaving the house for longer periods, for work or a day trip.

*The product needs to fulfill two main functions: capturing the urine and storing the urine. These two functions should not influence the shape and comfort of the seat and happen hygienically. The urine storage should be able to be emptied without the user having to leave his seat*

### Product requirements

#### Comfort

- » The product will not affect the comfort and shape of the seat, to prevent unwanted pressure distribution that results in pressure injuries.
- » The product cannot move or displace on the seat. And the product will not change its shape during the day. A powered wheelchair user is often not able to shift in their seat or change the product to improve their comfort.
- » The product does not have any sharp edges or rough surface texture, and the material is will not result in allergic reactions.

#### Capacity

- » The product should have a capacity of at least 2 liters. Large capacity will improve the mobility and freedom of the user, they can go on day trips without worrying about their urination. They won't need extra care moments during the day, which will save the caregiver time.
- » If the capacity is smaller than 2 liters and reaches its limit during the day, it should be able to be emptied without the user needing to leave their chair.
- » When moving the urine from the place of capturing to the storage place, it should not fill up or overflow. This will prevent the urine from coming back up and resulting in a wet feeling for the user. The product should be able to quickly drain 36 ml/s of urine and a total of 300 ml.

#### Ease of use

- » The placement and installment of the product to the seat should be fitted to the user. To fit the user's body anatomy.
- » Placement of the product to the chair or seat will not influence or limit the functionality of the wheelchair.

- » The caregiver will install the product in the morning before positioning the user in the wheelchair. The installment should not take longer than currently possible products.
- » When the user is placed in the wheelchair it should not move the product around, to reduce the time needed to get comfortable.
- » During the day the user can use the product handsfree and without assistance, excluding the assistance needed to get in and out of the chair.
- » The product should evoke natural urination behavior, that will not influence the user's urination behavior.
- » At the end of the day, the caregiver can remove the product easily without spilling and dispose of the urine and clean the product.
- » The client wishes to have a simple product solution.

#### Hygiene and Safety

- » The product may not leak urine, to prevent unpleasant smells.
- » The size and placement of the product should accommodate the unpredictability of the urine stream, to prevent spilling urine in unwanted areas.
- » The product can either be cleaned or disposed of.
- » The part of the product that captures and moves the urine does not hinder the urine flow or hold urine that will not reach the storage
- » The used materials are skin safe
- » The materials used are non-allergic

#### User

- » The product will function for females in an electric powered wheelchair that have limited to no upper body function
- » The caregiver can use the product without any risk (regulations of home caregivers)

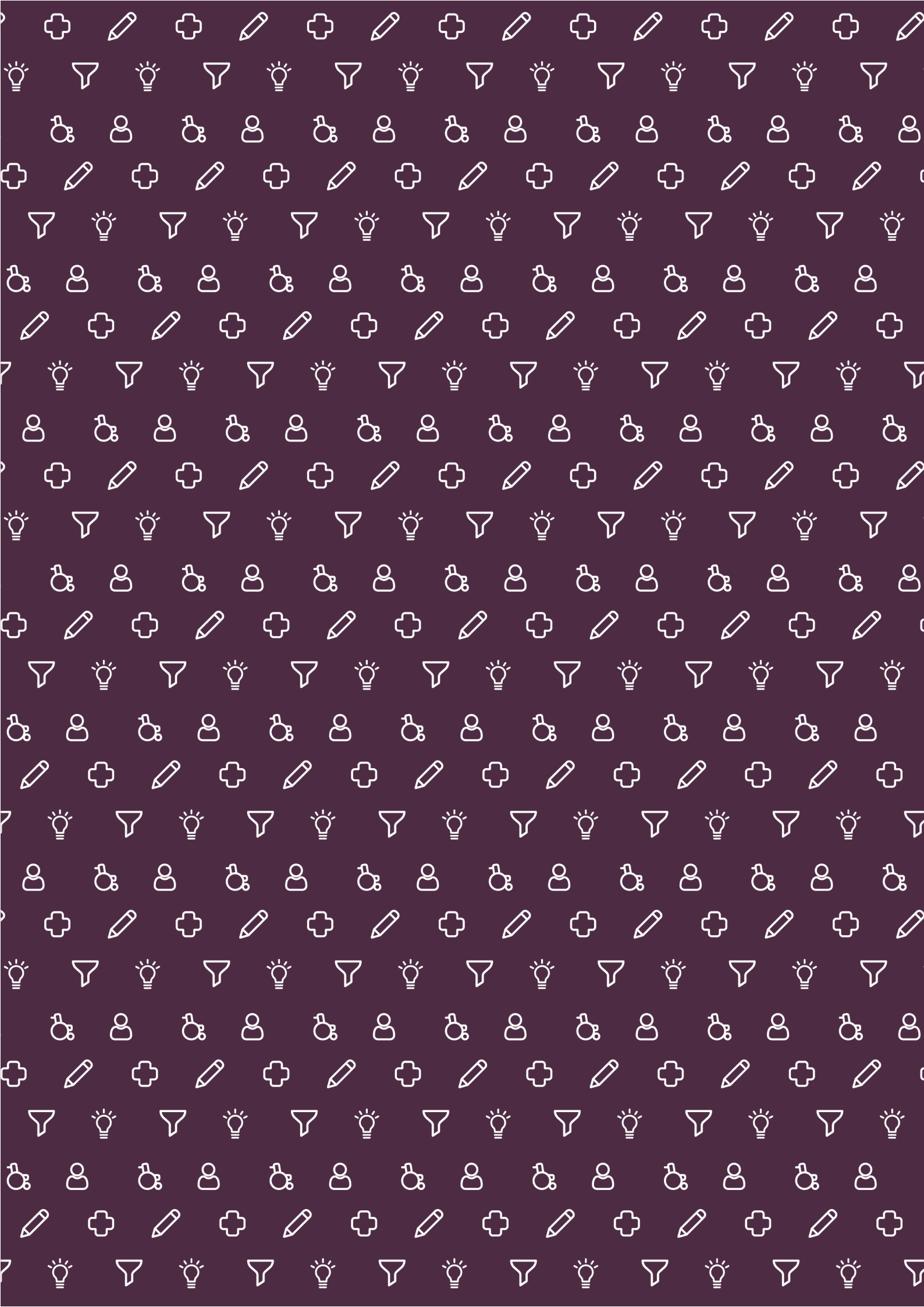





# Ideation

The analysis resulted in a clear problem that needs to be solved and a list of requirements that the product should meet. What the analysis did not conclude was one product direction that was convincingly better than the others. The flat diaper did have the highest score but also areas that needed improvement. In order to get a better idea of the possibilities, three design directions are established. For each direction ideas were generated to afterward be able to choose the most suitable direction.



The ideas from the chosen design direction were further elaborated upon, to generate four concepts. These four concepts were discussed in a presentation with the supervisors and client, to choose the best concept to further develop in the embodiment phase.

## 2.1 Design directions

The product needs to fulfill two main functions: collect the urine and store the urine. There are multiple multiple ways to perform these functions. Between the two functions, there is a third connecting function where the urine is moved from the collection location to storing location. Collecting and storing always happen in different locations to move the urine away from the body. The four products explored in the analysis use different ways to execute the three functions. A comparison can be found in Table 2.

The analysis did not indicate one product as the best option. With the use of the comparison table, three design directions were drafted. These design directions will be used to ideate a large number of ideas. Ideation will help determine which design direction is most fitted to solve the problem. The three design directions are shown in Figure 20.

- » Collect and storing urine on the seat surface
- » Collect the urine on the seat surface and move it outside of the seat surface
- » Collect the urine inside a wearable move it outside of the seat surface

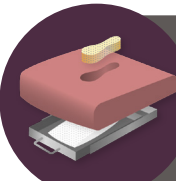
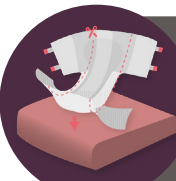
	COLLECT	MOVE	STORE	DISPOSE	POSSIBLE PROBLEM(S)
	Inside the bladder	Through a tube	Drainage bag (1-3 L volume)	Empty bag + Clean bag	Can leak and cause urine smell
	Directly at the urethra	Move down the material (capillary action)	Absorbent powder turns urine into gel	Dispose	Increase in thickness. Gel = hard. Does not last whole day.
	On the seat	Urine flows through the hole	In diaper material under the seat	Dispose + Clean drawer	Reaching the hole is difficult and seat cover can get dirty
	On the seat	Move down the material (capillary action)	Absorbent powder turns urine into gel	Dispose	Increase in thickness. Gel = hard. Does not last whole day.

**Table 2** Different ways to perform the functions: collect, move, store, dispose and the problems that come with it.

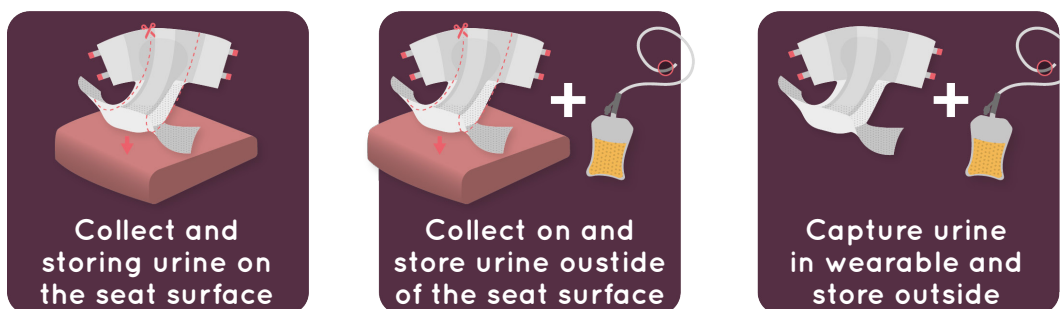

**Figure 20** Three design directions.

## 2.2 Ideation

For all three directions, ideas are ideated and explored. The morphologic chart technique was used to create ideas per function, to later combine these into multiple concepts. This process can be found in Appendix 6. There are two types of seats: a flat and an ergonomic seat (orthosis). There is a large difference between these two types of seats, which makes it difficult to design a solution that will fit both. Because the client uses an orthosis, this shape will be used as a base during ideation. The shape of the Lewis orthosis can be seen in Figure 21. A description of each design direction is given based on the ideated ideas. The ideas were evaluated using the four aspects of the design challenge: Comfort, capacity, ease of use, and hygiene. To identify the most suitable and feasible design direction, the generated ideas were discussed with the client and experts. The most suitable design direction was used to create four concepts. The full collages of the three design directions can be found in Appendix 6.

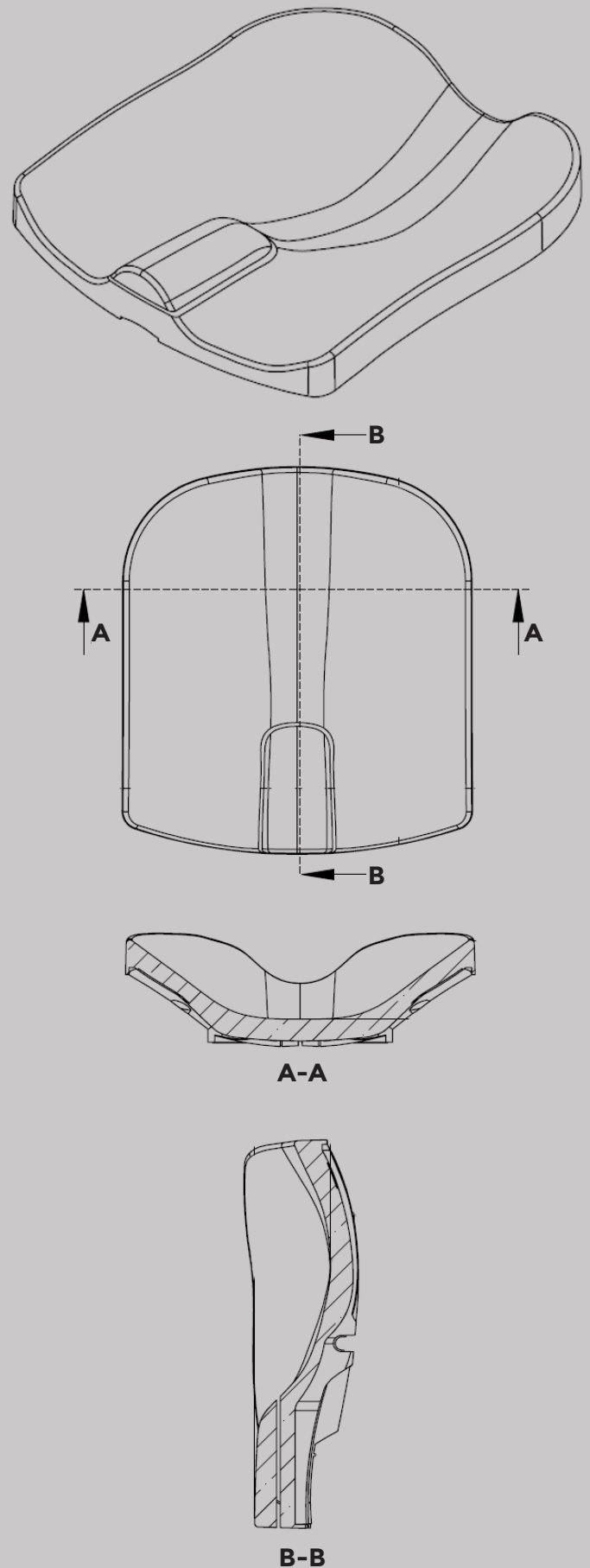

**Figure 21** Technical drawing of the client's seat orthosis by Lewis Seating Systems (Lewis Seating, 2019)

## Collecting and storing on the seat surface

The main challenge of this direction is to store the urine without causing hinder of discomfort to the user. Think of feeling wetness, accumulation of urine, or sitting on a water bed (instable). The ergonomic shape of the seat will likely cause the urine to gather at lower points on the surface, instead of spreading equally. Unfortunately, the lower area of the seat is also the areas were the critical pressure points are. Therefore this is the area where you do not want the urine to be stored. When collecting the urine on the seat surface (the middle), you want the move it to the sides. There are different ways to do this. Firstly, the urine could be collected at the lowest point of the seat. From there the urine is moved upwards against gravity with the use of tubing and a pump. Secondly, the principle of capillary action can be applied which uses surface tension to move liquids into narrow interstices. This principle is also applied in diapers to move the urine downwards without the possibility of moving upwards again. Instead of vertically, this principle could be applied horizontally to move the urine to the sides of the seat.

### Would it fit with the product requirements

This design direction will be a product that covers the whole seat, which is good for **comfort**. It does not expand in thickness as a diaper would, and therefore doesn't cause pressure point. However, the thickness required to incorporate a mechanism to move the urine will lower the comfort again. The thicker the product it more it will influence the ergonomic shape of the seat. Also, the client wants to sit as low as possible.

Moving the urine away from the seated area will increase the **hygienic** feeling compared to a diaper. But both drainage methods might work slow, which could influence the hygiene. The desired **capacity** can be reached, but it will depend on the location and concept. The placement of the product is easy because it can be placed on the seat. The **ease of use** in terms of **cleaning** and disposing of urine is more difficult for these ideas.

Altogether, this a very complex design direction. The overall feasibility of these ideas is low because there are too many uncertainties. It all depends on the urine drainage, which requires the urine to move upwards around 10 cm to the sides (see figure FIX). If the urine drainage doesn't succeed, there are concerns that it will be very unhygienic and uncomfortable.

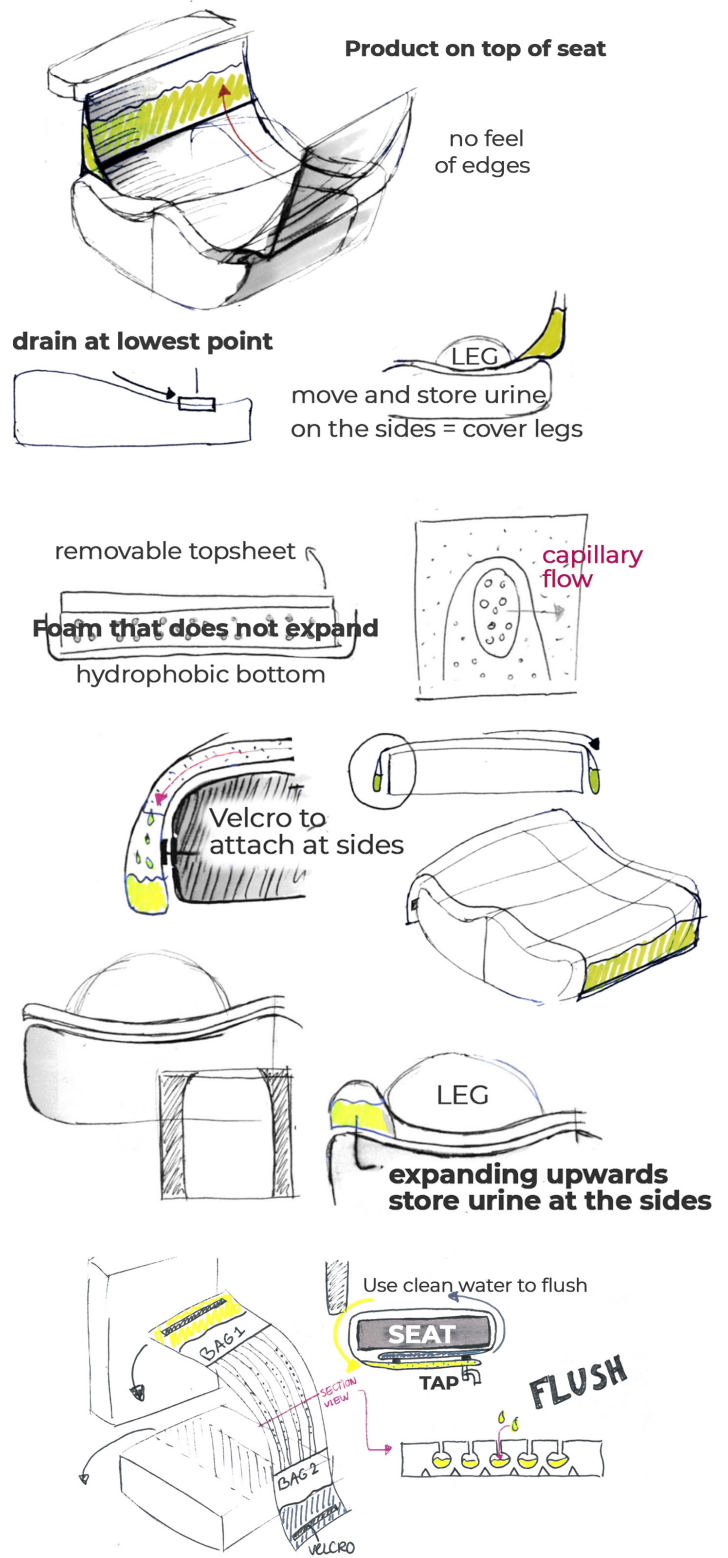

**Figure 22** Ideation for the design direction: collecting and storing on the seat surface.

## Collect urine inside a wearable and move outside of the seat surface

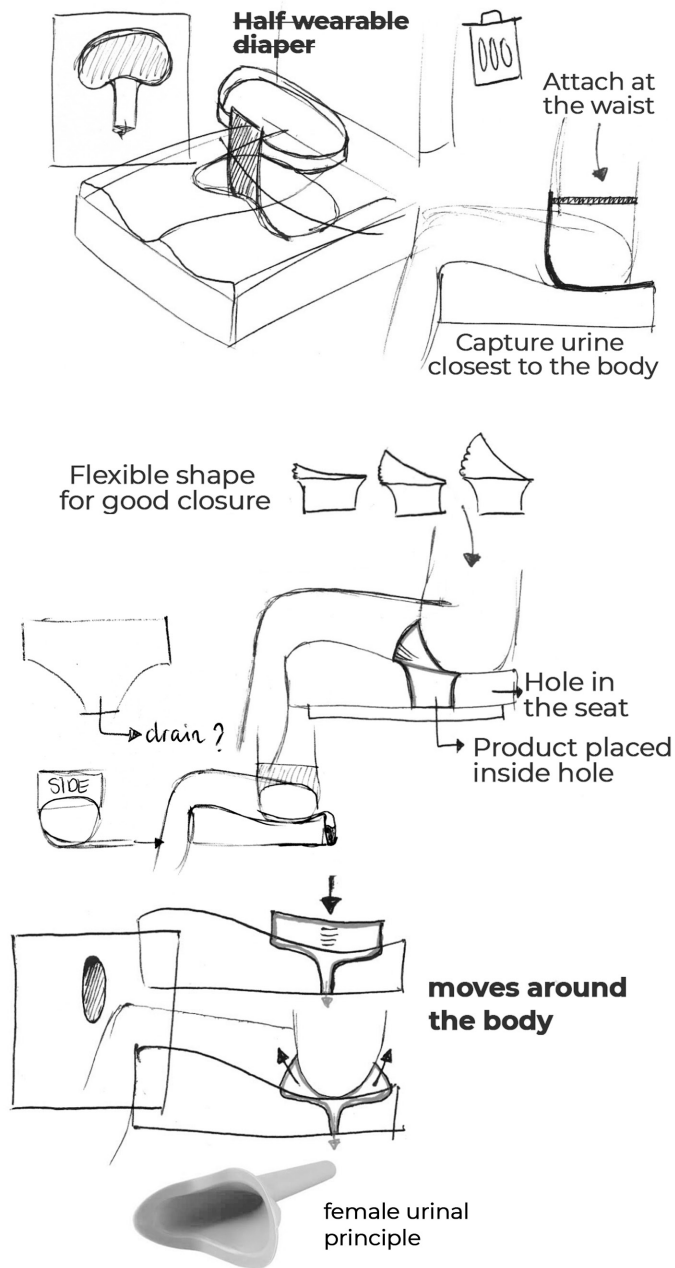

**Figure 23** Ideation for the design direction: collecting urine inside a wearable and move outside of the seat surface

Diapers are not experienced as comfortable and practical by the target group. The main issues are the short duration of use and difficulty of changing the diaper. But the advantage of a wearable product is being close to the body and therefore controlling the urine stream. A new wearable could be like a diaper, but more suitable in a sitting position. The wearable should move the urine away from the place where it's captured, in order to last the whole day. Taking the clothing of the user into account, the most logical direction is downwards. Therefore these ideas are combined with a hole in the seat (prototype) and storage underneath the seat.

### Would it fit with the product requirements

The biggest advantage of a wearable is the control over the urine spread. There is less chance that urine will end up on unwanted areas. There is less chance of accidents, making it more **hygienic** than the other two design directions. It follows the curve of the body, therefore it should not interfere with the user's **comfort** (Vink & Hallbeck, 2012). An expert on toileting solutions expressed the importance of making the solution close to the body, to achieve a good functional product (Loth. M., personal communication, 2019). On the other hand, if the shape does not follow the body correctly and is not properly closed, it could cause problems that interfere with the hygiene and comfort.

The main downside of having a wearable is that the caregiver needs to put it on. This requires the user to lay down again after their morning routine (e.g. washing), which is time-consuming. The user is **very dependant** on the caregiver. Moving the urine away from the seat makes it possible to make the **storage** as big as needed to last the whole day. No changes during the day would be needed, which is an improvement from the normal diaper. This design direction is far outside of the wishes of the user that the direction is not desirable to continue with. However, because not all ideas in Figure 23 are wearables. It would be interesting to combine the shape that follows the body with the next design directions.

## Collect urine on the seat surface and store it outside of the seat

This last design direction was based on the prototypes with the hole in the seat. The biggest issue with this concept was that the lack of support given in the area of the hole. To solve this issue the hole should be filled but still let the urine flow through. The material used to fill the hole should have the same characteristics as the seat, to make the transition between seat and opening unnoticeable. One direction is to cover the seat and opening with a full seat sized silicone cover. This material is flexible and hygienic. The cover will protect the seat from becoming wet and help smooth out the edges around the hole. The hole is filled with a structure similar to the softness of the seat. This will provide support to the user and let the urine move through. A whole different way of draining the urine is to move it over the edge at the backside of the seat. This idea makes use of the tilted position of the seat to create a slide of some sort. At the backside of the wheelchair, the urine can be stored in a container. This size of the container is not limited, because it does not interfere with the functions of the wheelchair. This idea requires a recess in the topdeck layer of the seat, which is less drastic than a hole. A recess also keeps the structure and shape of the seat intact, which prevents the feeling of sitting on an opening.

### Would it fit with the product requirements

Making a hole or recess requires an alteration to the wheelchair seat, which is quite drastic. But it has its advantages. The hole or recess provide fast drainage of the urine. It also makes the placement of the product **easy to understand** and it will not move or displace on the seat (**comfort**). The feasibility and benefits of this design direction outweigh the required adjustment. A hole is disadvantageous compared to a recess because it let's cold in from the bottom. The main challenge of the design direction is the **comfort** of the seat. The material that fills the hole should have the same compression as topdeck layer of the seat (see Appendix 7). Adding an extra toplayer onto the product will give a nice edgeless feeling to the user. According to M. Loth, it could potentially slow down the urine flow (personal communication, 2019). This could reduce the chance of urine reaching the hole and interfere with the **hygiene**.

Having the storage of the urine under the seat provides **independence** because they can reach the drawer to empty it (requires arm function). The client explained that she experienced this as pleasant. However, this location limits how far the seat can go down because it takes up a little of this space. A good alternative is to place the storage unit at the backside of the wheelchair. This will provide more freedom in the **volume** of the container.

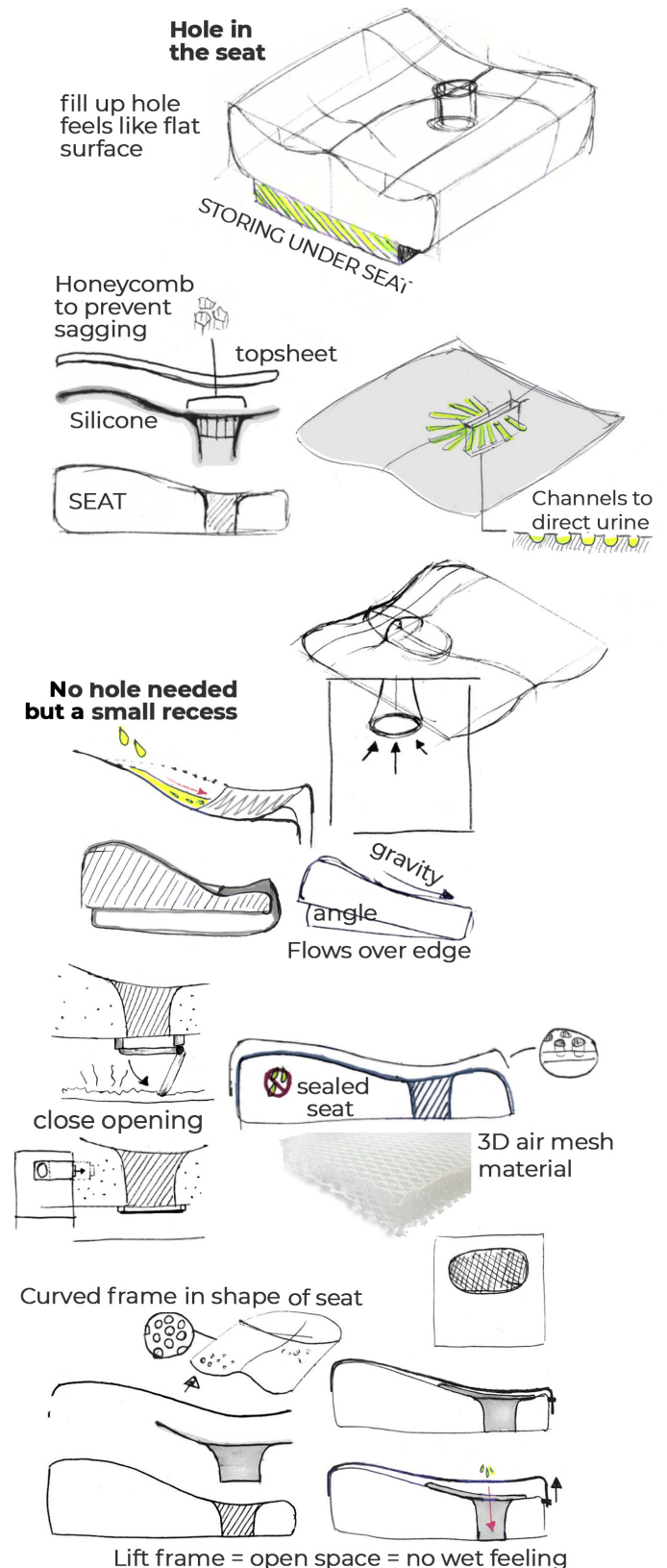

**Figure 24** Ideation for the design direction: collect urine on the seat surface and storing it outside of the seat surface.

## DIRECTION CHOICE

*Ideas within this design direction can meet the problem definition within the given time and knowledge, which makes them more feasible than the other two directions. This direction also has the most potential in terms of comfort, because it adds very little thickness to the seat surface. At the same time, comfort is also the biggest challenge. The required alterations the seat needs make it difficult to apply it to a regular flat seat than the other directions. Some elements of the wearable design directions could be interesting to include in one of the concepts. The way the wearables capture the urine could be interesting to add during the conceptualization.*

## 2.3 Design directions

From the chosen design direction, four concepts were developed based on two principles. The first, having a hole in the seat and a product that covers the whole seat to protect it. The second, making a recess instead of a hole and move the urine over the edge of the seat at the back. To better substantiate the feasibility of the concepts, some small material tests were down, which can be found in Appendix 7.

# Concept 1

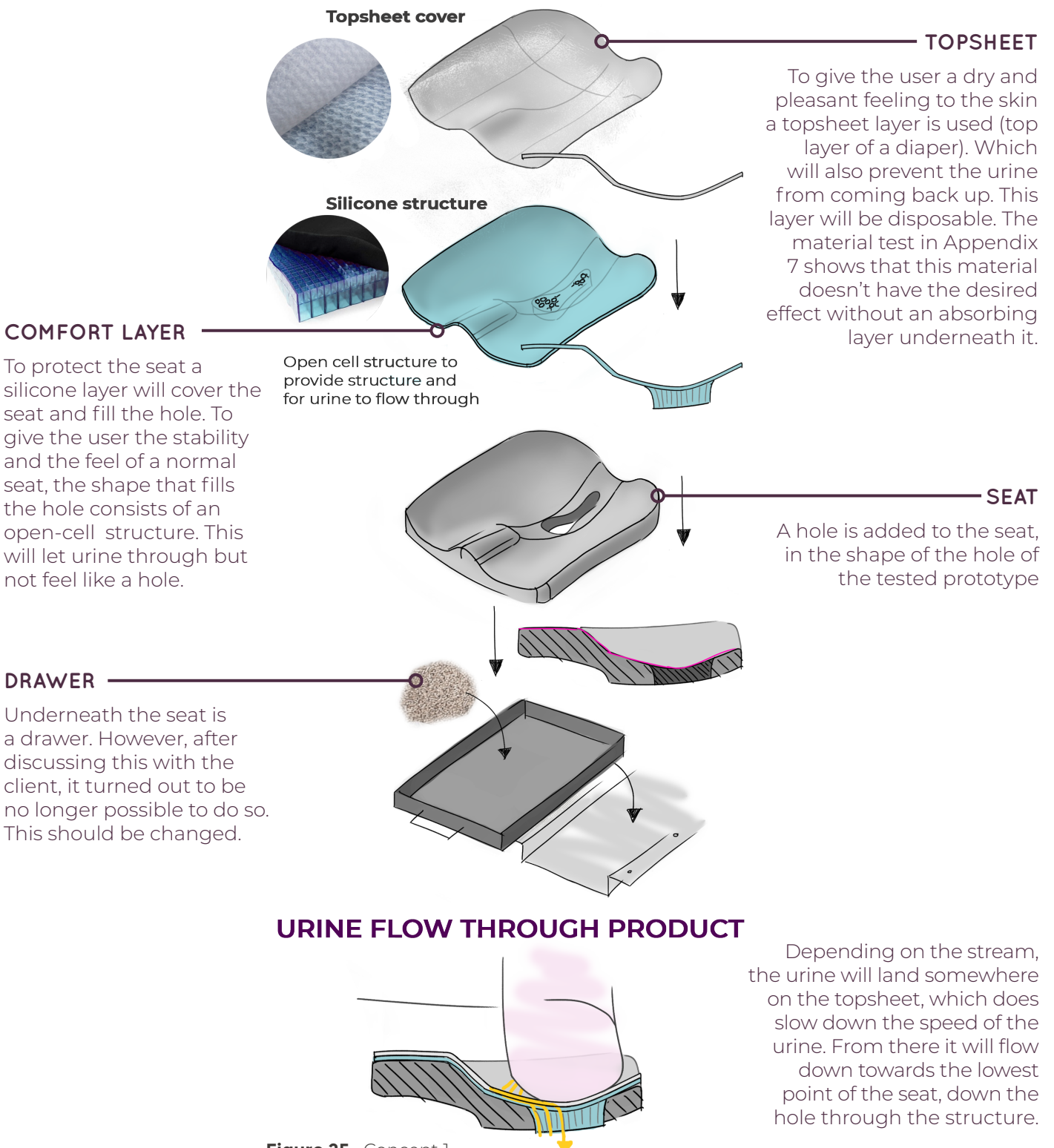

Figure 25 Concept 1

# Concept 2

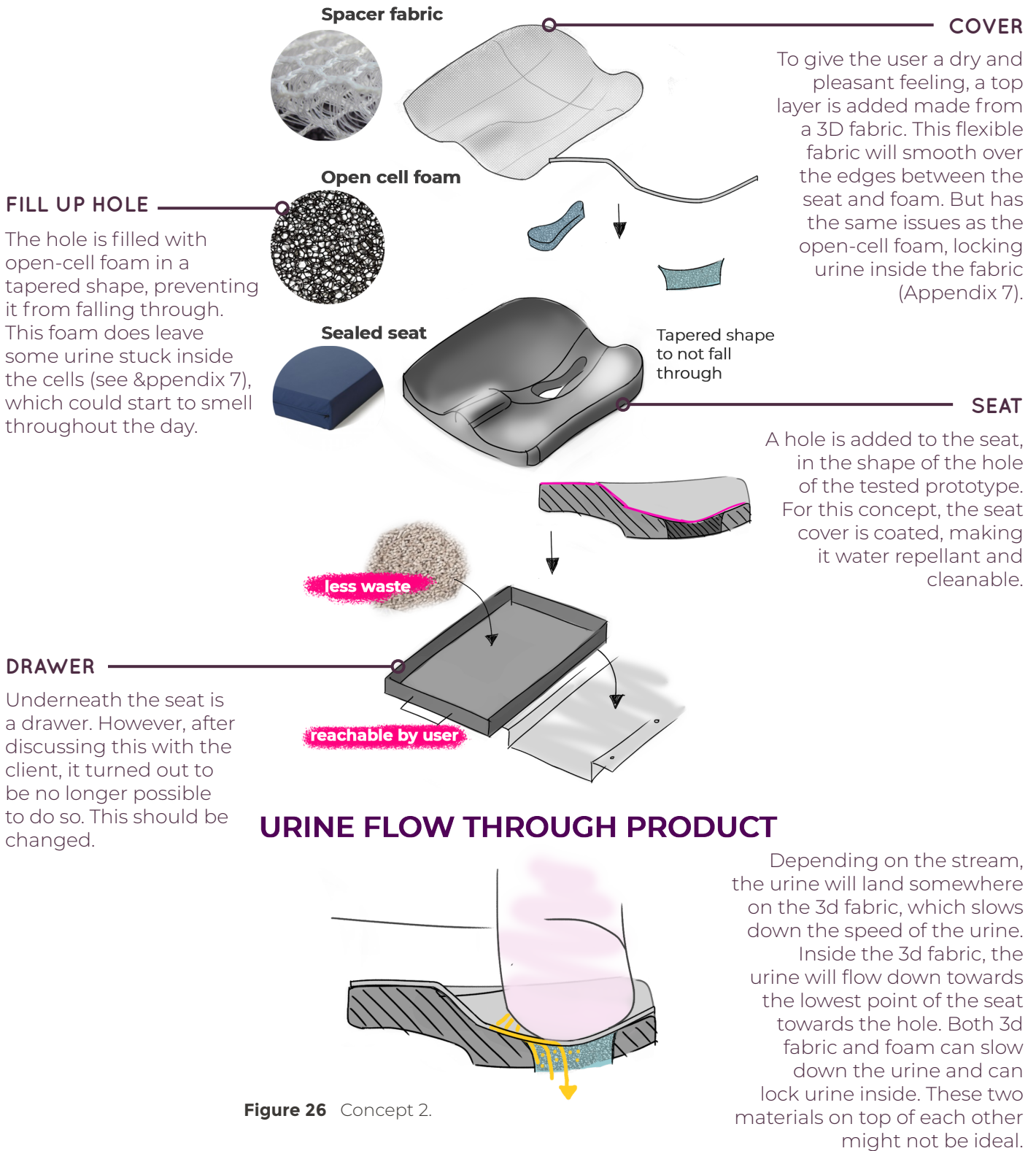

Figure 26 Concept 2.



# Concept 3

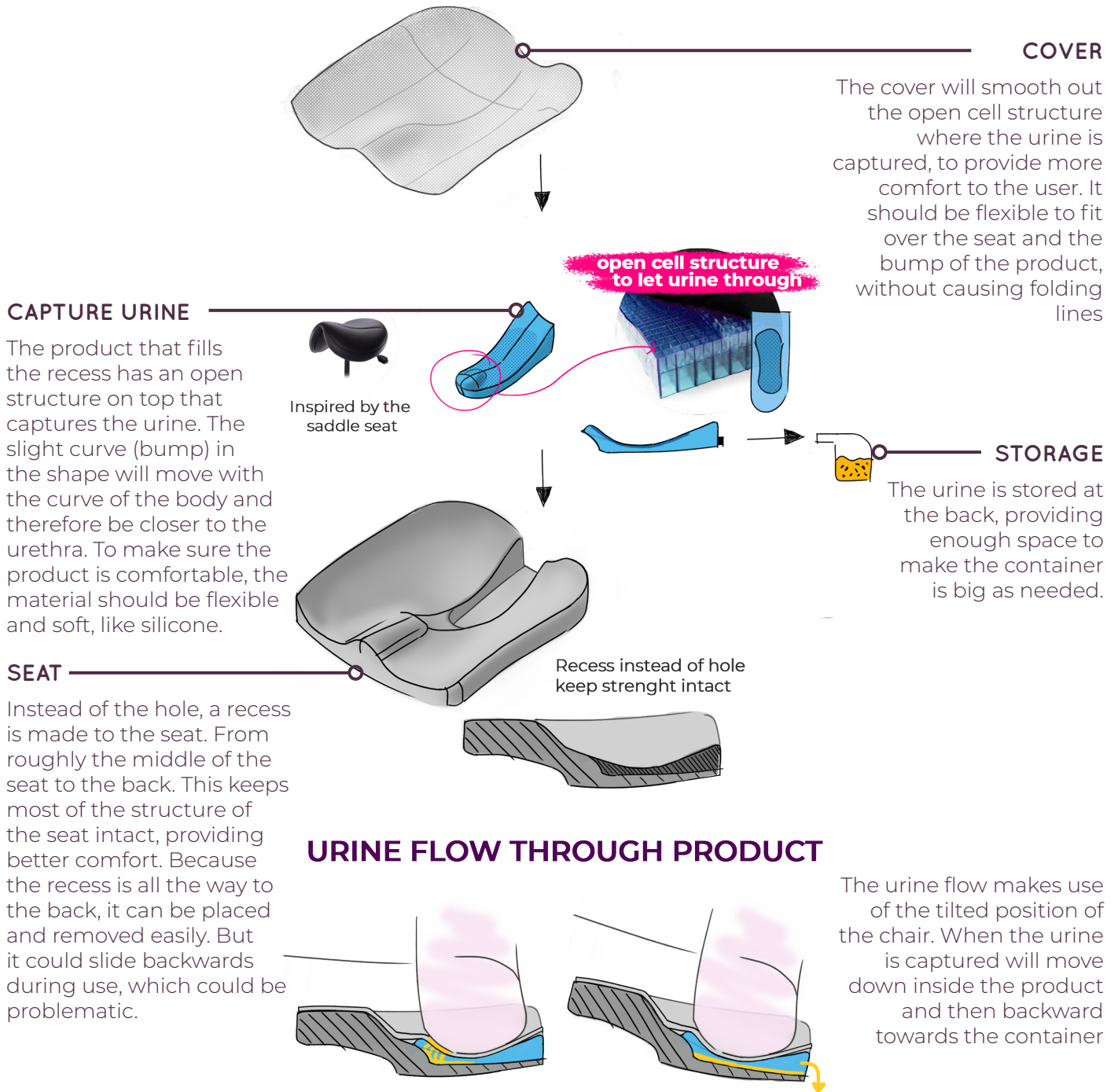

Figure 27 Concept 3.

# Concept 4

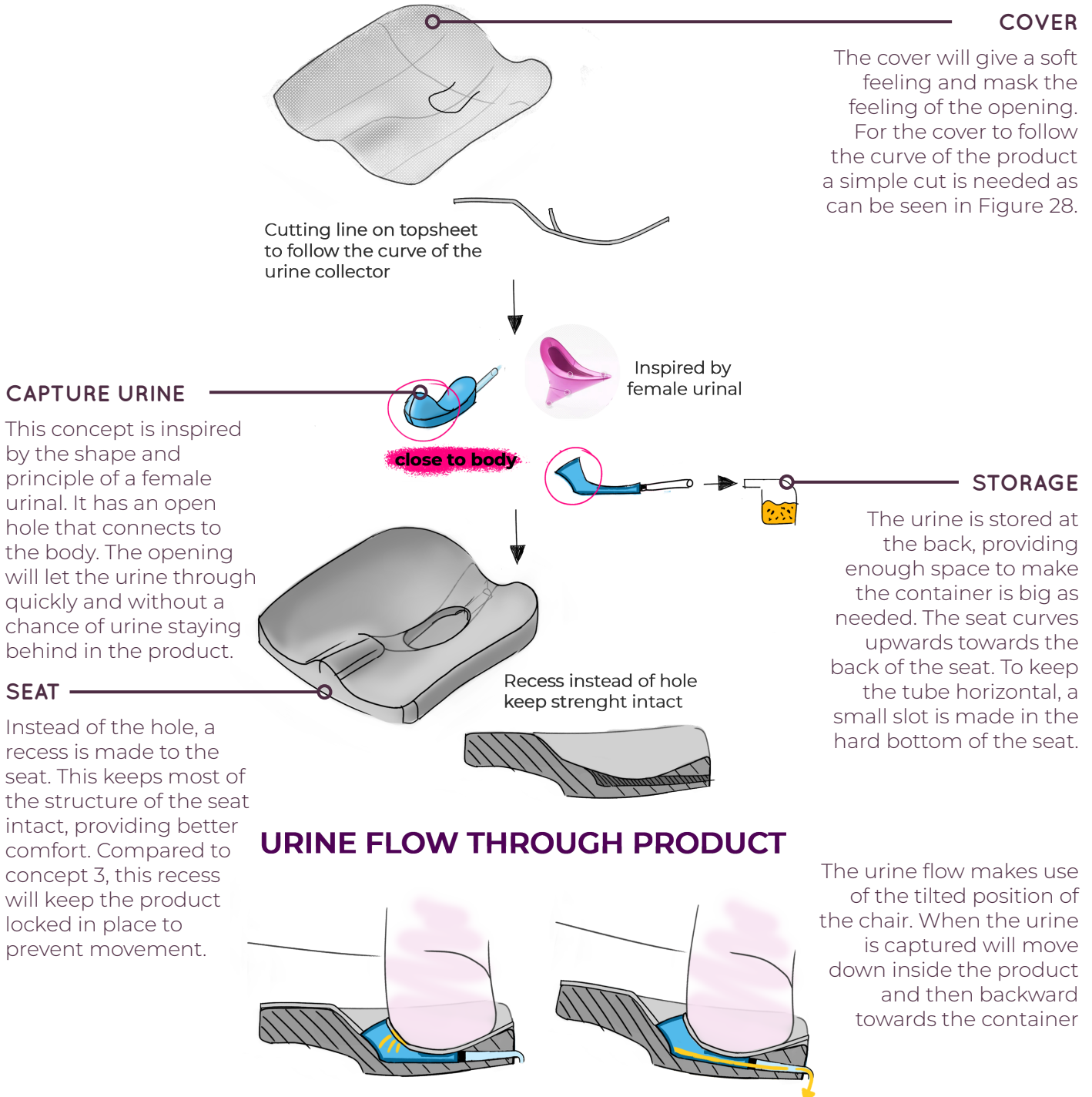

Figure 28 Concept 4.

## 2.4 Conclusion

The concepts were presented to the coaches and the client. The most suitable and feasible concept was chosen and will be further detailed in the embodiment phase. The concept choice happened in two steps.

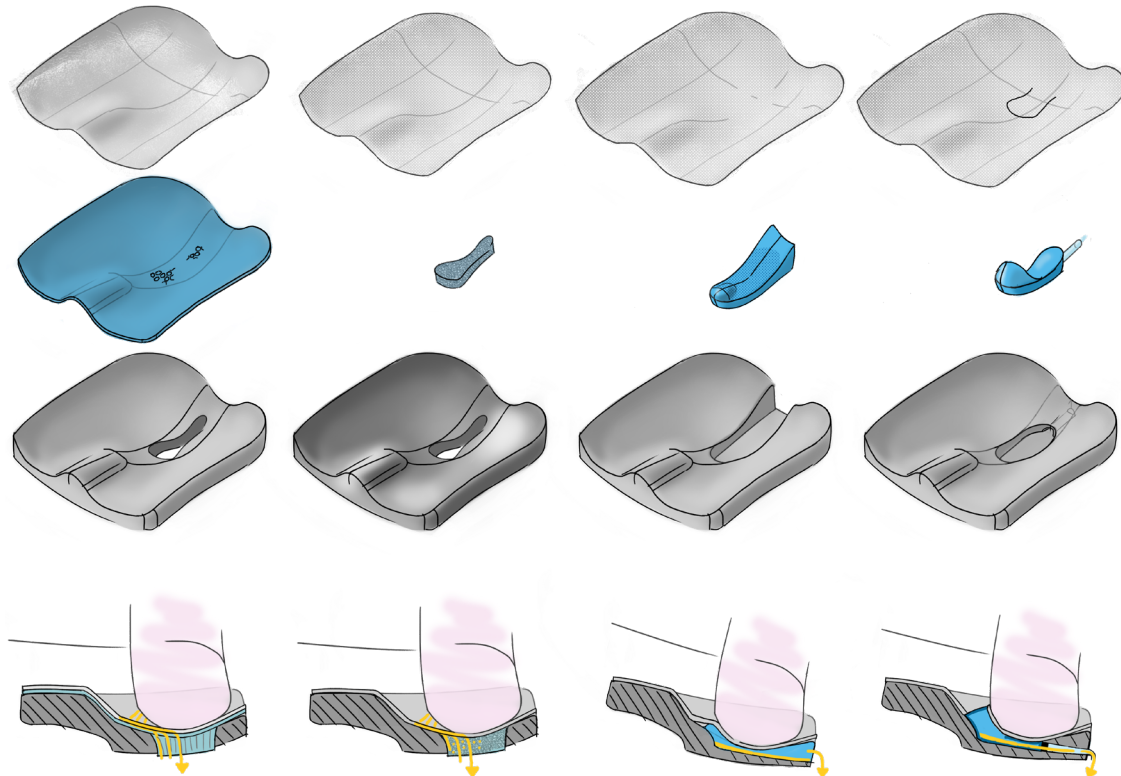

Figure 29 Four concepts.

### STEP 1 | Which principle is most suitable, hole or recess

There are two principles to choose from, the hole and the recess. The hole brings more complications than advantages because part of the structure and stability of the seat will be lost, and cold can easily move through the hole. While the recess only requires modification of the topdeck layer and one small change to the hard foam structure. Therefore these concepts will be easier to adapt over time. If the product needs to be repositioned, the topdeck layer can be replaced. The recess principle also has the potential to be adapted to a separate product that can be laid down on a flat seat. To reach users that don't have a seat orthosis.

Collecting urine closely to the urethra is assumed more effective because of the shorter travel distance. In concepts 1 and 2, the urine needs to flow down toward the lowest point before it can move to the container. While in concepts 3 and 4, the urine flows immediately into the product. Besides, the recess moves the urine to the back of the wheelchair instead of below the seat, making it more applicable to different types of wheelchairs. And this storage location will not influence wheelchair functions. Making the recess the best principle to choose.

### STEP 2 | Expected comfort between concept 3 and 4

All concepts have a top layer, which will help smooth out any small edges. Resulting in a similar feeling. The main difference between concept 3 and 4 is the positioning of the product. Concept 3 could slide backward out of the recess. Changing the positioning of the product, and therefore negatively influence comfort. While concept 4 is locked into place.

In the material tests, the results showed that structure could lock liquids into the material. This can be a potential problem in terms of hygiene. This makes concept 4 the most feasible and promising concept. Discussing this concept with a design engineer at Lewis Seating Systems did not result in any initial issues regarding the changes made to their seat.

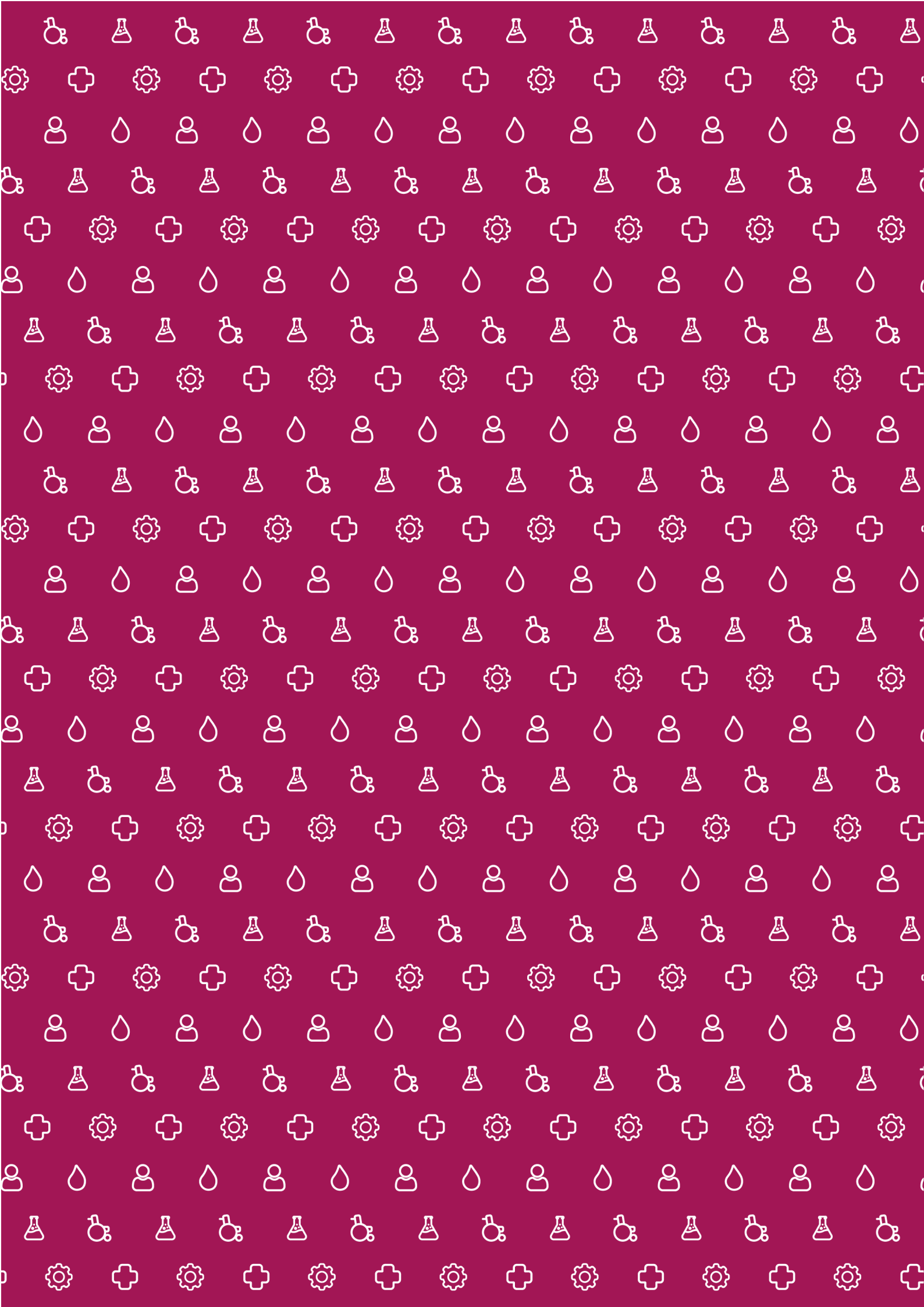

# Embodiment

This chapter will focus on the further development of the chosen concept and the research needed to find the right sizing, shape, and materials. All the topics covered in this chapter will contribute to the functioning and success of the product. Because the concept requires a change to the wheelchair seat and the client uses a Lewis seat orthosis the embodiment will focus on making the product fit to this type of seat. To substantiate the end product multiple tests were conducted. The conclusion of the test will be discussed in this chapter and the full test description can be found in the appendix.

This chapter is divided into 3 topics: comfort, functioning, and usage. Each topic will be explored to finalize the product. The comfort of the product will dive into the materials used and the shape and curve of the product. The aim is to make the product as unnoticeable for the user as possible and prevent discomfort. Because users sit on the seat statically throughout the day, the comfort is of high importance because the users will have little to no ability the reposition.

The function of the product focuses on the purpose of the product, which is to capture the urine and move it to the place where it is stored. This topic will look into the size of the pipe to get a fast enough drainage to meet the maximum flow rate of a female. And lastly, the usage of the product will mostly focus on how the product is installed and how it is can be cleaned. This will also include the caregiver. these three topics will be merged into the final design of the product.

## 3.1 Product comfort

Comfort is a very important quality of the product, which will determine its success and improve the quality of life of the user. An uncomfortable product is not suitable for long term use. As described in the analysis, comfort is better described as the absence of discomfort. Discomfort will require the user to move around to improve their comfort (feedback loop), which is difficult or not possible for this target group. Making comfort essential for this product. For the product 4 elements of comfort will be explored, which are also visualized in Figure 30:

1. **The material.** The material chosen will need to be biocompatible and comfortable. The part of the product that is sunken into the seat will need to have the same shore softness as the seat to get a smooth transition between product and seat, to make it unnoticeable. See Figure 30, the stippled area.
2. **The curve and opening:** the curve will have to follow the curve of the body and provide closure to prevent leaking during urination.
3. **Positioning of the product** will determine if the product will follow the curve of the user.
4. **The toplayer** covers the whole product and seat to hide any edges from the product, and have a soft dry feeling, like sitting on a normal seat.

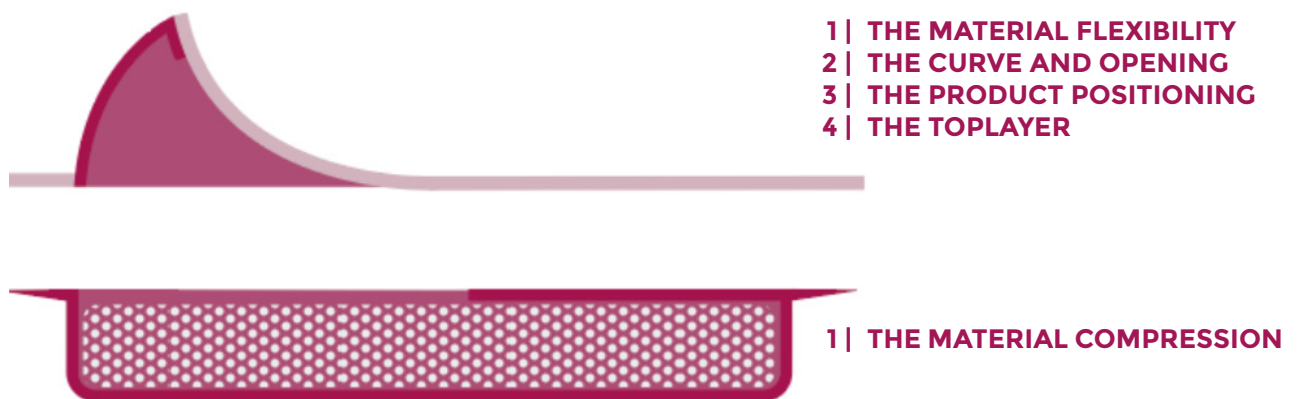

**Figure 30** The 4 areas of comfort and to which part of the product they belong.

### 3.1.1 Materials and softness

#### MATERIAL REQUIREMENTS

The material will determine the possibilities in the shape, feel and functioning of the product. The material choice is important because there is prolonged body contact at an intimate and sensitive area of the body. Therefore the material choice is made first. In order to do so, the material requirements were used, which were: flexible,

comfortable, water-repellent, body-safe, non-allergenic, antibacterial and cleanable. The most suitable material was medical-grade silicone. Table 3 shows how this material meets the requirements.

<b>Flexible</b>	The shore A value can range for 0 to 95.
<b>Comfortable</b>	The shore hardness of silicone rubber can be ~40, which makes it non-abrasive toward biological tissues (Rahimi & Mashak 2013).
<b>Water-repellent</b>	Water absorption <1 (%) ("Characteristic properties of silicone," 2016).
<b>Biocompatible</b>	It's chemically stable which makes it suitable for long-term body contact and its antibacterial to reduce infections (Plastics for Medical Use, 2015).
<b>Hygienic</b>	Sterilizable and it limits bacteria development which will prevent infections (Rahimi & Mashak 2013), Silicone is also odor and stain resistant.
<b>Form freedom</b>	Because of the flexibility, the material is easily releasable from a mold.
<b>Shape-retaining</b>	Will always form back to its original form.
<b>Durable</b>	High tear strength ("Characteristic properties of silicone," 2016)

**Table 3** Silicone material specifics.

#### PRODUCTION METHODS

The target group for this product is small, which eliminates large-scale methods like injection molding. Silicone has the advantage that it can be both 3D printed and can be cast, which makes it suitable for both a custom or a standard sized product. However, there is a big price difference between these two techniques which should be taken into consideration. Since the choice will

depend on the product being custom or standard, it's still relevant to have both options. Both options come with pros and cons, which can further steer the solution in one of the two directions. Table 4 summarizes the pros and cons. For prototyping, there is also an alternative material to silicone called elastic resin.

	<b>SLA Silicone</b> ( <i>"3D Printing in Silicone"</i> , n.d.)	<b>Casting</b> (Silicone & Urethane Casting, n.d.)	<b>SLA Elastic resin</b> ( <i>prototyping alternative</i> ) (MATERIAL DATA SHEET, 2019)
<b>Price</b>	€€€€ (+/-450)	€€€€	€€€€
<b>Size [mm]</b>	limited - 300x445x200	unlimited	small 125 x 125 x 165
<b>Smoothness</b>	●●○○○	●●●●○	●●○○○
<b>Precision</b>	●●○○○	●●●●○	●○○○○
<b>Shore A</b>	0-60	0-95	50
<b>Body safe</b>	✓	✓	✓
<b>Watertight</b>	✓	✓	?

**Table 4** Three production methods and their characteristics.

**SOFTNESS**

Softness is can be expressed in shore hardness, which is the resistance of a material to penetration of a durometer. Silicone can range from shore A 0 to 95. The product can be divided into the top and bottom, which each require a different type of softness. The top part needs to be flexible to form to the curve of the user’s body. This will form a seal to prevent leaking, this principle is used in female urinal devices. Flexibility with silicone is easily achievable through thin wall thickness, but it should not be too flexible that it can deform with one wrong move.

The softness of the recessed part of the product needs to be soft in a foam-like manner, to match the softness of the topdeck surrounding it. This will make the product imperceptible. The topdeck has a density of 60 kg/m<sup>3</sup> which translates to a shore A value between 0 and 20 (see appendix 9). However, a Shore A 10 silicone test cube showed barely any compression (see Appendix 10), because silicone does not have foam-like characteristics. There are two options to create the desired effect, thin and thick walled, which can be found in Table 5. In Appendix 10 the material test results can be found that dive into the possibilities with the silicone material (See Figure 31).

**A | DESIRED SCENARIO**

**UNCOMPRESSED STATE**



**COMPRESSED STATE**



**The product needs to align with the foam topdeck. When the foam compresses because the user sits on it, the product will need to have the same compression to stay aligned.**

**B | THIN WALLS**

**PROBLEMS**

**COMPRESSED STATE  
COLLAPSE**

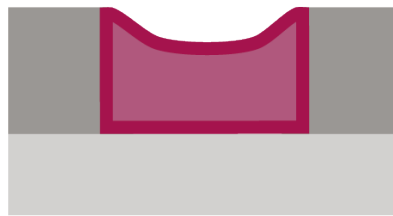

**COMPRESSED STATE  
PRESSURE POINTS**

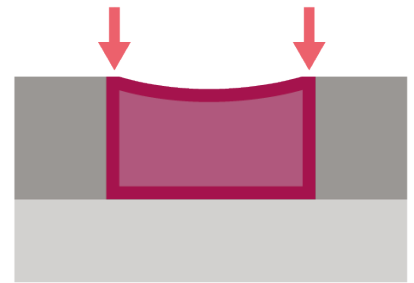

**SOLUTION**

**COMPRESSED STATE  
INFILL STRUCTURE**

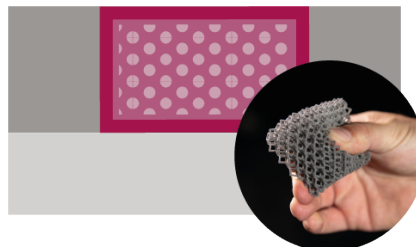

A thin-walled product will not provide enough stability and therefore collapse or deform under pressure. Giving a dented feeling. To solve this a structure can be added. This could be a separate part or 3d printed together with the outer walls (see image of a 3d printed lattice structure). But as mentioned before, structures can trap liquids inside (e.g. open-cell foam). The amount of liquid trapped could be dependant on the cell size of the structure.

**COMPRESSED STATE  
ANGLED WALLS**



A thin-walled product with infill and straight walls will result in palpable edges. The inside of the product will have a certain amount of compression, while the edges won't. This could result in high pressure around the edge of the product. To reduce the perceptibility of the edges they are given an angle and a brim. This will divide the pressure over a larger area.

**Table 5** The wanted scenario of the product under compression (A) and the possible problems that can occur (B+C).



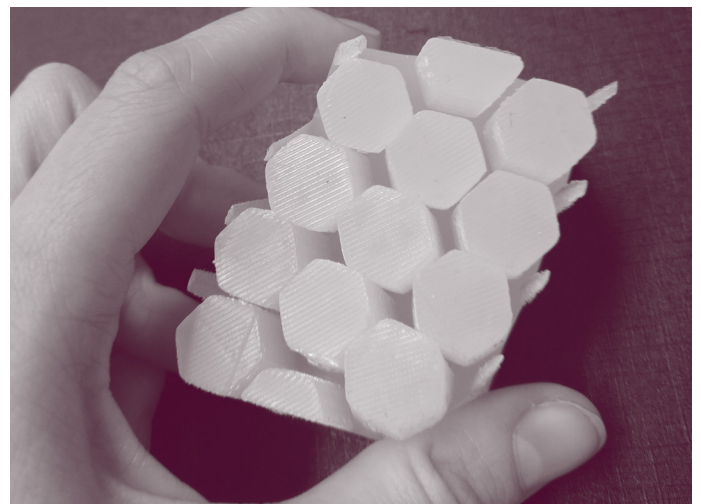
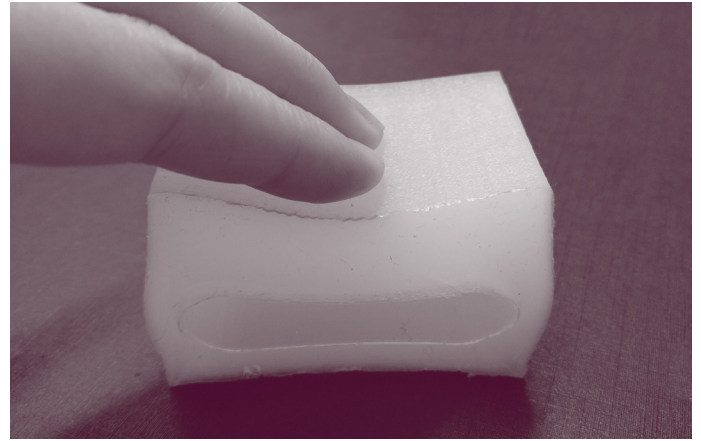
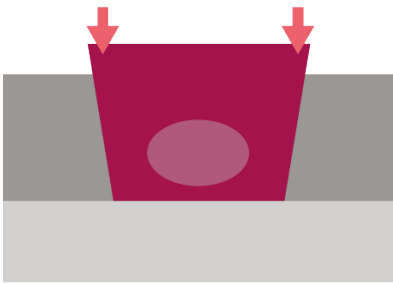

**Figure 31** Silicone material test blocks, to research the flexibility and compression of the material.

## C | THICK WALLS

### COMPRESSED STATE

*PRESSURE POINTS*



### BEFORE : AFTER

*LOWER HEIGHT*

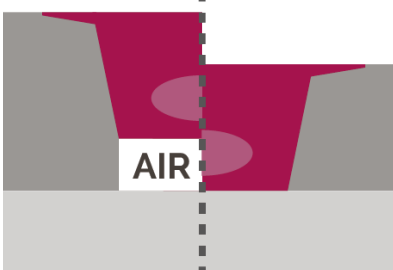

A thick-walled product will not have the same compression as the topdeck foam. Under compression, the product will stick out resulting in high-pressure areas at the edge of the product. As a solution, the product's height can be reduced. When the topdeck is compressed the product will move downwards to stay aligned. To prevent the opening from collapsing under pressure, enough surrounding material is needed. Adding a brim and angled walls (like the thin option) will prevent the product from falling through.

The thin-walled option has fewer potential problems. The structure needed inside a thin-walled is a disadvantage when it comes to urine drainage. This could influence the hygiene and comfort of the product. A thick-walled product has a funnel-like opening which does not obstruct the urine flow. The challenge of the thick-walled solution is finding the right height. This will be discussed later on in this chapter, which dives into the choice between custom and one size fits all. Because the shore value has the most influence on the flexibility of thin walls, the shore value of the silicone should be based on the top part of the product. Which is between shore A 10 and 20.

### 3.1.2 The curved shape

The top part of the product has a curved shape that sticks out of the seat. This shape is based on the female urinal devices (FUD), that help females to urinate while standing up. The curved shape functions as a seal to close to around the vulva and capture the urine directly at the urethra. The two main questions that arise regarding this topic are:

- » *Is the curve of the female body unique (custom product) or similar?*
- » *Is this curve the same in a sitting and standing position?*

#### CUSTOM VS. ONE SIZE FITS ALL

Whether the product becomes custom or not will mostly depend on the female anatomy in the area of the curve that is shown in Figure 32. But, it will also depend on an available technique that can map the curve in a way that is applicable for powered wheelchair users. All the considered techniques can be found in Appendix 11. Resulting in a foam imprint as the most suitable and feasible for the target group, while also being more comparable to the real situation of sitting on the orthosis. However, when testing this technique with the available foam sheets it didn't give enough detail to be usable (Figure 33). A larger thickness would be required to get to full shape, which would need to be produced.

It is well known that the shape and size of the vulva are very unique for every female (O'Keefe Osborn, n.d.). Because the product will have an opening that will edge around the vulva, only the size needs to be taken into account. The average labia majora size is 80 mm with a standard deviation of 15 mm (Kreklau, et. al., 2018). Therefore, the opening should be at least 110 mm, to fit 95% of the females. However, less is also known about the actual curve and if there's a lot of variation between individuals.



**Figure 33** The result of the foam imprint test, where the foam was not thick enough to capture to full shape

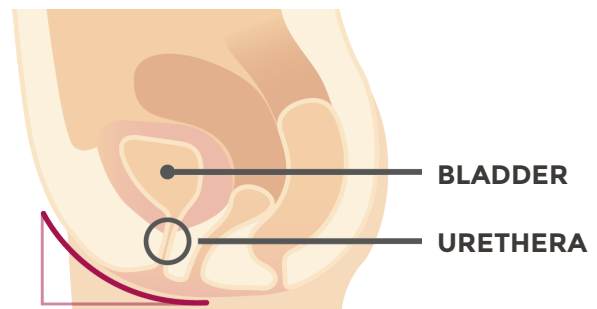

**Figure 32** Silicone material test blocks, to research the flexibility and compression of the material.

*“I can imagine that the curve is similar per person. There is not much variation in, for example, the size of a pelvis and the anatomy of, for example, the bladder and uterus. However, people do have a varying amount of fat tissue” (Boersma, personal contact, 2020).*

The curve is assumed to be similar and therefore a custom product is unnecessary as well as limited by its production method and the possibilities to digitize the curve (see ch. 3.1.1). But similar is not identical and as mentioned, people do have varying varying amount of fat tissue. Figure 34 shows the location of fat tissue, which is located especially on the belly. Therefore a third option would fit the product, namely a sizing system like: small medium large. This will make the product castable, and lower the production cost compared to 3D printing. The fitting process will also be faster and easier (see ch 3.1.3). The variation in sizing could be the size of the opening and the width of the product. But it should also include the bodyweight of the user. The bodyweight of the user relates to the previously described problem with the compression of the topdeck and the firmness of the product. This will determine the height of the recessed part of the product. A more in-depth explanation of this topic can be found in chapter 3.1.1. Due to the time limitations of the thesis, the specifics of this sizing system are not further researched.

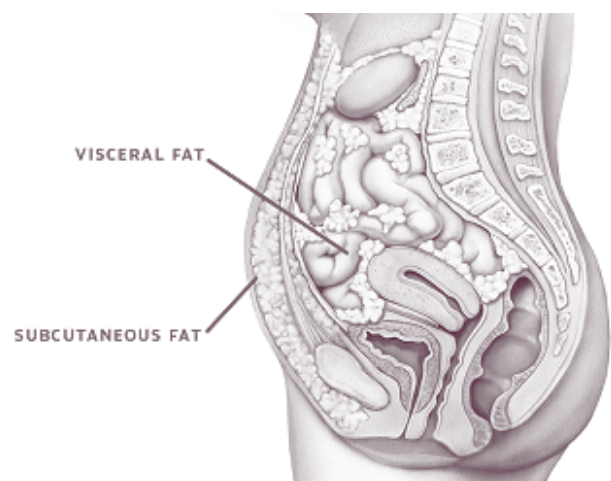

**Figure 34** Fat distribution, the difference between visceral fat and subcutaneous fat.



**Figure 35** 3 tested female urination devices.

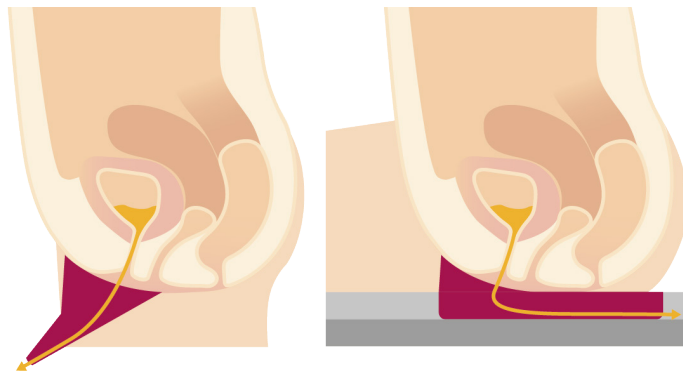

**Figure 36** The difference between the FUD in standing and sitting position and the test set-up.

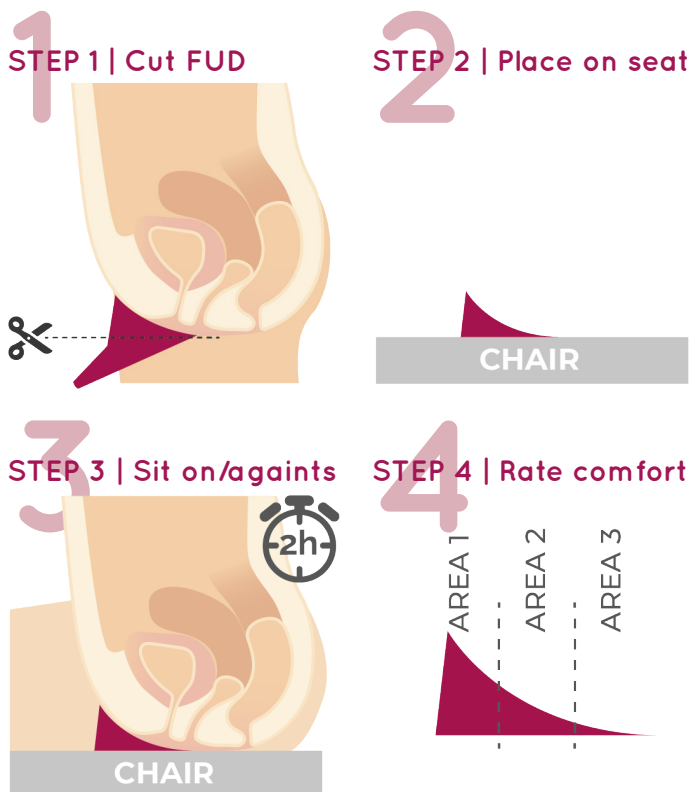

**Figure 37** The test set-up for the FUD duration test.

### FUD: DIFFERENCE BETWEEN SITTING AND STANDING

The FUD's are designed for standing use and are held into place by the users, putting pressure on the top and bottom to create good closure. In a sitting position, the closing pressure is a result of the user sitting on the product, making it possible to use handsfree. FUD's made from soft silicone are more difficult to hold securely in place, while a hard silicone FUD was easier to position, but didn't seem to fit every woman (Gaskell, n.d.).

In order to see how the shape and closure of the FUD's translate from a sitting to a standing position a test was conducted. The full test set up and result can be found in Appendix 12. This test was conducted using three different types of FUD's, one from harder silicone and two from softer silicone (see Figure 35). For the test the top curve of the FUD's was cut of and punt on a chair. For a duration of two hours the comfort of sitting against the curved shape was tested. Figure 37 shows the set-up of the test.

The main results from this test were that the softer silicone material was more comfortable, while the hard silicone already started to become painful in certain areas after one hour. Because of the high risk of pressure injuries due to static sitting, soft material will be better suited. The softer material was more comfortable and also was easier to position. In shape and size both soft FUD's seemed to fit the body well, likely because of the material flexibility. The only downside of the silicone material was that it became a little sweaty after two hours. Which emphasizes the need for an extra top layer for comfort (see chapter 3.1.4). This top layer will also be able to cover the hole and therefore reduce the feeling of sitting on and against an opening, which was experienced during the test. This will limit sensible edges and is assumed to limit the chance of pressure injuries and discomfort.

### 3 Embodiment

#### FINAL CURVED SHAPE

Combining all the gathered knowledge about the curved shape resulted in the final curve as shown in the figure. The final curved shape of the product did not become custom nor one size fits all, but a sizing system is applied (small medium large). To find the right curve multiple steps were taken and are explained in Figure 38.

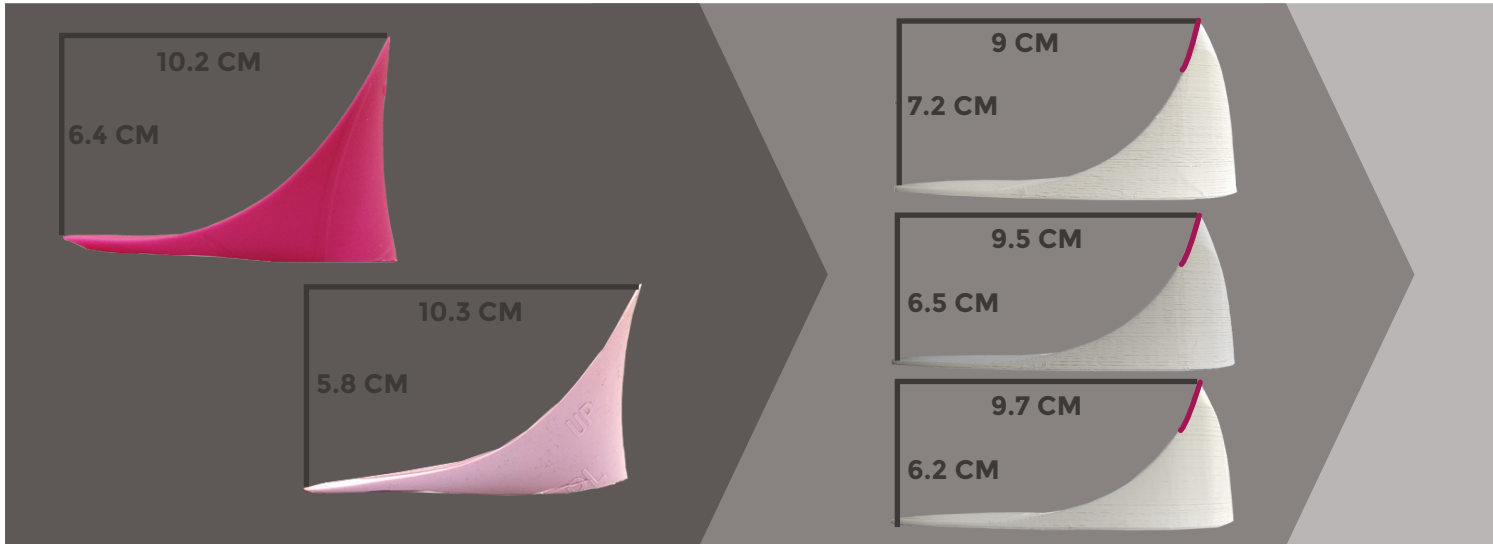

#### STEP 1 | FUD duration test

The previously mentioned duration test was used to test the experience of sitting against the curve. The main conclusion was that the curve was good but on the small size.

#### STEP 2 | 3D printed curves based on the FUD's

Because the FUD's were on the small size, 3 models were 3D printed in different sizes. The hard printed material highlighted a possible high-pressure point at the top (yellow circle) and a gap at the bottom of the curve. The middle curve, with a height of 6,5 cm, was the most comfortable out of the three.

Figure 38 Steps taken to find the curved shape

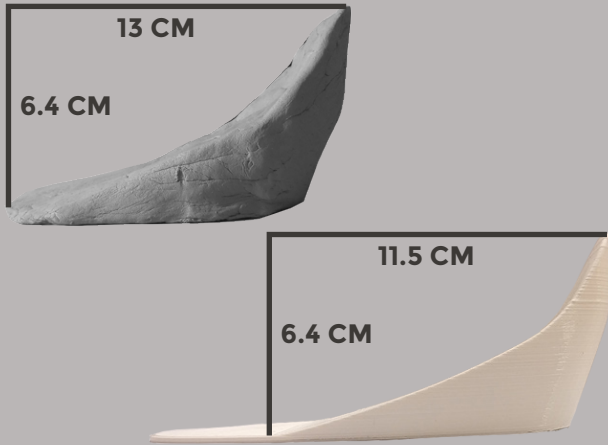

### STEP 3 | Clay model

The FUD's are made for standing use and were also comfortable in a sitting position, But the hard 3D printed curve did show a small gap at the bottom of the curve. This could indicate that the curve in sitting position should be changed to guarantee good closure. A clay model was made to find the curve that would fill the gap. The shape was digitized and printed to highlight possible high-pressure points, which were not present,

### STEP 4 | Foam model

The foam model was used as reference to the clay model. They had a similar curve at the bottom of the curve, but the foam was not thick enough the capture the full shape.

### STEP 5 | The final curve

All the curves are overlapped to see which parts stand out and which are equal. The yellow line represent the two custom shapes as a result of the clay and foam model. The final curve (white line) is larger in size and has a different curve than the FUD curve from the first step. This curve is assumed as most suitable in the context of the assignment. This curving can be used as a starting point for a future sizing system. This size would be able to fit the 11 cm opening needed.



### 3.1.3 The product positioning

The comfort of the product is dependant on more than the curve only. The placement of the product on the seat surface will determine if the curve will follow the human body. If the product is too far forward it will not be closed properly. Too far backward could cause too much pressure. This clarifies that the correct position is important for proper functioning.

The product location is dependant on the positioning of the body on the wheelchair seat and the abdominal depth, which is dependant on the body shape of the user. Data found in Dined shows, as can be seen in Figure 40 and Table 6 that the abdominal dept of females increases with age (Anthropometric Database, n.d.). While the buttock-popliteal depth and hip breadth change less. So while the product itself is not custom, the placement should be determined per individual.

The Lewis seat orthosis makes it easier to guarantee a good body-product connection every time. The seat will guide the user in the wanted position that will result in a good and consistent posture. The consistent position on the seat makes the location of the hips of the user very predictable. This is favorable because the product cannot be moved easily. Based on the sitting position of the user, the location of the product can be determined. The product should be part of a fitting process. For example, during the fitting process of the Lewis orthosis. Because the users body can change over time it is important to have check-up appointments. When the product need relocation, only the topdeck foam needs replacement and the hard scale of being reused.

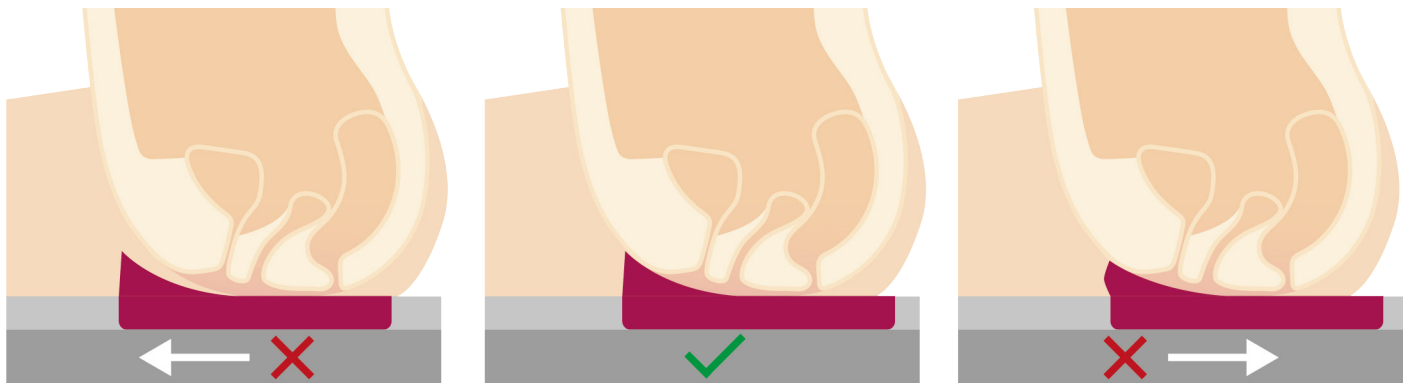

Figure 39 Three types of product placement.

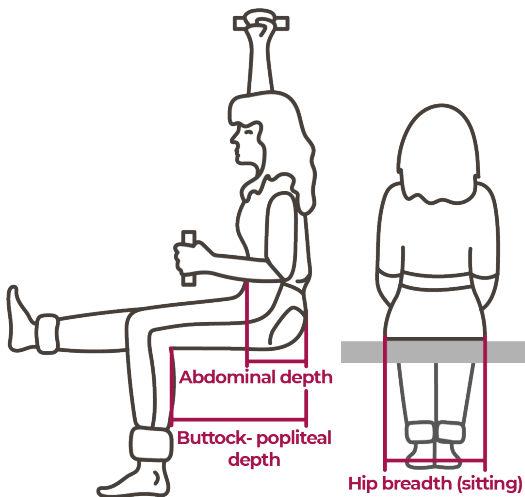

Figure 40 Sitting female (Anthropometric database, n.d.)

POPULATION	DUTCH ADULT 20-30, FEMALE		DUTCH ADULT 31-60, FEMALE		DUTCH ADULT 60+, FEMALE	
	MEAN	SD	MEAN	SD	MEAN	SD
Abdominal depth	236	32	293	38	313	39
Buttock-popliteal depth	497	28	499	27	492	27
Hip breadth, sitting	402	27	414	31	410	34

Table 6 Dined values for sitting females (Anthropometric database, n.d.)

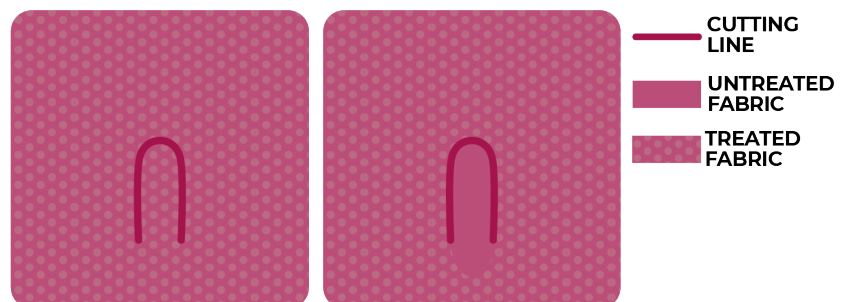

Figure 41 Two options of fabric surface treatment. Left: full surface treatment, right: surface treatment excluding area covering the product.

### 3.1.4 The toplayer

The product will consist of a fabric toplayer, which will cover both the product and the wheelchair seat. This is the last element that will provide comfort to the user. This fabric toplayer will provide a soft and dry feeling to the user, instead of sitting on plastic which will start to feel sweaty over time (appendix 12). But more importantly, it will mask the feeling of the opening and edges of the product, lowering the chance of pressure injuries. However, fabrics normally have absorbent characteristics, while the opposite is desired. Since the urine will go through the fabric, it needs to have very good permeability and not cause odor. Two aspects of the toplayer will be explored: the material functioning and the connection to the product and seat.

#### FABRIC MATERIAL

Most fabrics will absorb liquids like a sponge, but there are exceptions. Think of sportswear and of course diapers. The toplayer of a diaper lets the urine go through and prevent it from coming back up (Appendix 3). However, this material is very thin and would not mask the edges and opening of the product. To find the most suitable material, multiple fabrics were tested. The material test can be found in Appendix 7. The resulting material choice is a 3D fabric, also known as a spacer fabric or 3D air mesh. This material is used for medical applications, like preventing bedsores (Qin, 2016). Which is in line with what it should do for this product. The material has multiple advantageous properties:

- » **Ventilating.** *It reduces heat build-up and allows air circulation.*
- » **Moisture-regulating and permeability.** *This prevents fungi and helps dries the material fast. It prevents sweating*
- » **Shape-retaining and strong.** *This makes the material durable.*
- » **Non-toxic.** *It is already applied in the healthcare sector. This makes the material skin safe.*

Spacer fabric, in its normal composition, consists of a top and bottom layer connected through distance fibers giving the material a certain thickness. The test showed that this would lock part of the liquid in the middle layer. Removing the bottom layer will solve this issue and improve the urine flow. There are two possible options when it comes to provide the user with a dry feeling. The regular fabric will let the urine through but absorb a small amount of liquid leaving the fabric a little damp. After treating the material with a water and dirt-repellent treatment, the fabric did not spread the liquid through the material. This left the material dry, except for the place where the liquid was applied. That area would leave a small layer of liquid behind, feeling wetter than the untreated material. A user test should reveal what is most comfortable. If an untreated fabric is more comfortable than the surrounding should be treated anyway. Treating the surrounding material will protect the seat. Figure 41 shows the two options.

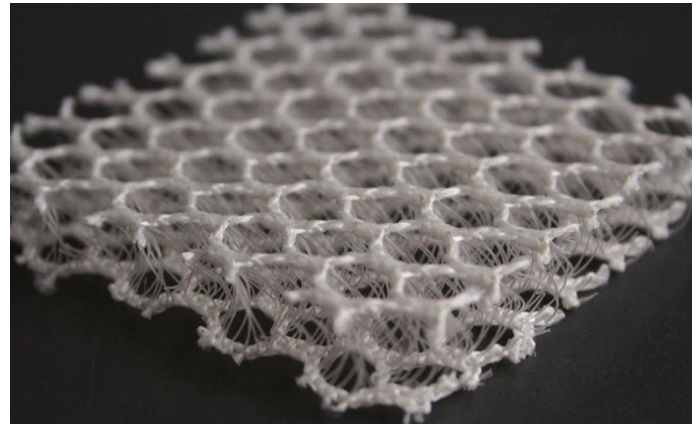

Figure 42 Spacer fabric.

#### TOPLAYER CONNECTION

The top layer should be connected to the product, to prevent unwanted movements. There are two options possible, which are described in Table 7. Having a separate is more efficient during cleaning, because the toplayer can be washed and the product can stay inside the seat and be flushed through. An extra connection to the seat can be added if this turns out to be required (Chapter 4 evaluation).

<h1>1</h1>	<h2>Product and fabric glued together</h2>
<p>No chance of movement or shifting of the toplayer          Sil-Poxy™ is skin safe and flexible, it can connect fabrics and silicone together and maintain the flexibility. (Sil-Poxy™, n.d.)</p>	
<p>Product needs to be cleaned as a whole, and therefore fully removed every day.          Wear to the toplayer would mean replacing to whole product, because they are glued together.</p>	
<h1>2</h1>	<h2>Product and fabric as separate parts</h2>
<p>Easy removal          Put in the washing machine for cleaning, while the product can stay in the seat for cleaning.          Possible to have multiple toplayer for one product.</p>	
<p>The connection needs to provide good security, to not detach during use.          The attachment method should not be feelable.</p>	

Table 7 Two options to connect the fabric.

## 3.2 Product functioning

*Comfort is a very important quality of the product, but the functionality of the product is just as important. The product functionality consists of two parts: the urine drainage and urine storage. Both will be covered in this chapter.*

### 3.2.1 Urine drainage

#### BUFFER VOLUME AND TUBE DIAMETER

The urine is collected at the opening (curved part) of the product where it will flow into the product. To drain the urine into the container, both are connected to a tube. The product and tube should be able to drain 36 ml/sec to handle the maximum flow. The drainage of the urine can be approached as a funnel. The drainage of a funnel is dependant on the height, the diameter, and buffer volume. If the buffer volume is too little it will overflow and spill onto the seat. A large diameter will ensure fast enough drainage but also at risk of becoming perceptible. There should be a good balance between the buffer volume and the inside diameter (Figure 44).

To find these values a test was conducted. The shape was modeled based on the gained knowledge of the previous chapter (3.1 comfort). This resulted in a possible buffer volume of around 30 ml, which takes the angled position of the seat into account (Figure 44). 30 ml is slightly lower than the maximum uroflowmetry of 36 ml/sec. To the product, three different tubes were connected with the inside diameters of 6, 7 and 8 mm. During the test, 300 ml (urination volume) is added to the product with a speed of roughly 36 ml/sec. The container was placed on three different heights, to look at its relation to the drainage. The results were: (full results in Appendix 13).

- **6mm** is too small. Only at a height difference of 25 cm was the tube and buffer able to drain the water. However, it was close to overflowing. At the height difference of 15 and 5 cm, the buffer did overflow.
- **7mm** was able to drain the water. Only at 5 cm height difference was the buffer close to overflowing. At the 15 and 25 cm height, the buffer was used but did not come close to overflowing. This diameter would suffice but could become risky if a user has a higher maximum urine rate.
- **8mm** is the most ideal diameter. This diameter did not cause the buffer to (come close to) overflow. The buffer was barely needed and the height of the container had little effect on the drainage speed. This will be advantageous for the applicability to different wheelchairs.

#### TUBING CONNECTION

To connect the tube to the product a barb fitting is used. A barb is a common used connection between tubing, which is used in the medical sector. They are chosen because of their convenience, reliability, and performance (Williams, 2019). The barb fitting will create a seal between the tube and the fitting, which is highly blow and pull-off resistant. An example of different types of barb fittings can be seen in Figure 43. Inside the funnel their should be a smooth transition between the barb connector, the product, and tube to prevent urine from getting stuck inside edges (Figure 44).

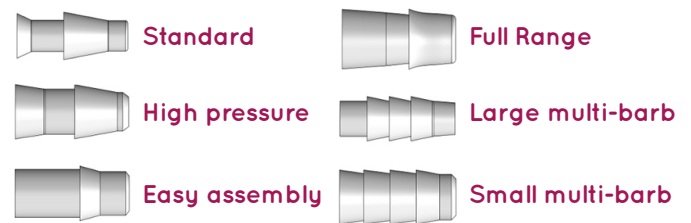

Figure 43 Different types of barb fittings (Williams, 2019).

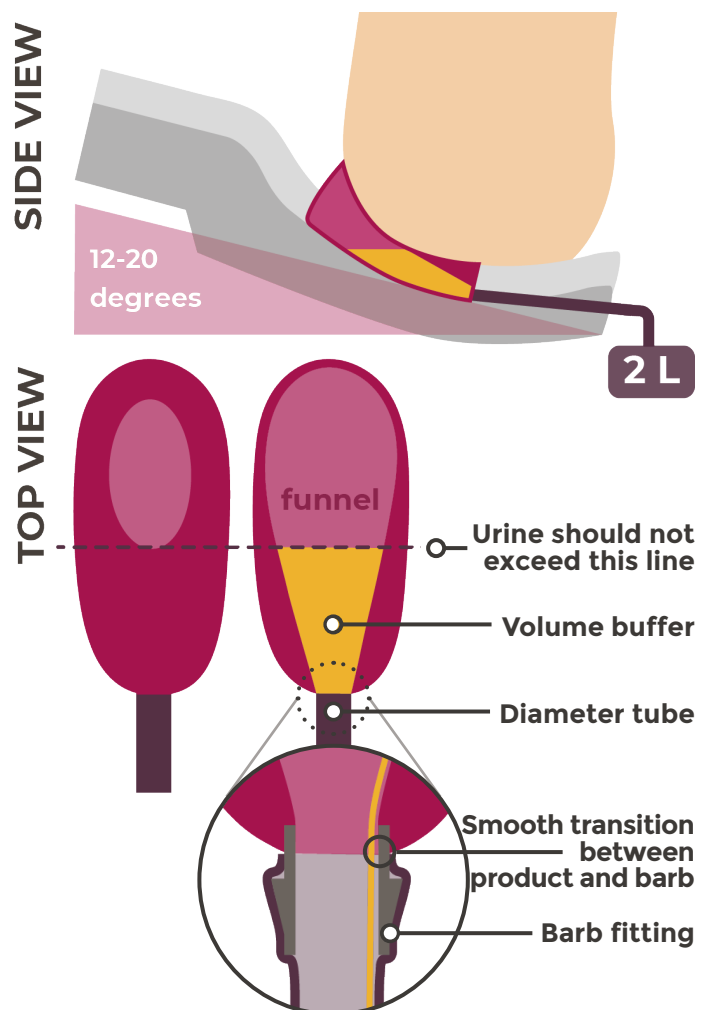

Figure 44 Visualization of the drainage inside the product.



### 3.2.2 Urine storage

The urine is moved to the back where it will be stored during the day. At the end of the day, the urine needs to be disposed of. The wheelchair seat can move into different positions (see Figure 3, chapter 1.1.1) and the urine storage should not interfere with this. Fixing the container to the wheelchair could cause blockage or kink of the tube, which in return could cause problems for the drainage during use. Therefore, the container should maintain some freedom of movement. There are two options for the storage of the urine: a container or a bag.

#### 1 Urine container

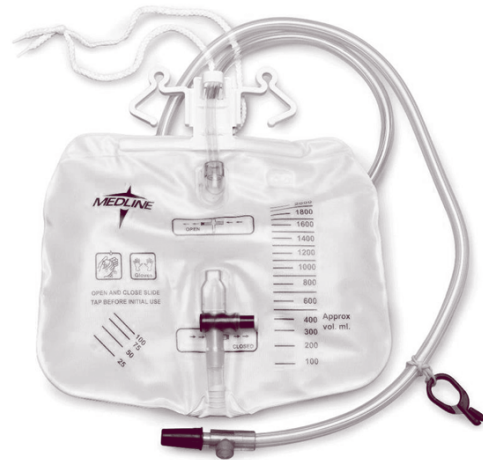

**Figure 45** 24h urine Container with a capacity of 2,5 L and super absorbant pellets (Absorbent Pellets, n.d.).

There are standard containers available that can store up to 2,5 L, like the one in Figure 45. The container has a very fixed shape, which makes it difficult to attach it to the wheelchair in a way that maintains freedom of movement. To guarantee a good flow into the container a small opening needs to be made to let the air out and urine in. Without an opening, a vacuum arises that impedes the urine flow. Even though the opening can be small, it can still let odor out of the container. Therefore this option needs to include an additive to capture the urine odor.

There are two ways of storing urine. It can be stored as a liquid or as a solid. Storing the urine as a liquid makes it easy to dispose of it because the contents can be flushed down the toilet. To limit sound and smell an odor neutralizer (liquid) can be added to the container. Placing the tube into the neutralizer will prevent a pouring sound. However, the liquid can create a sloshing sound while moving around in the wheelchair, making it noticeable to the surrounding. Therefore storing the urine as a solid would be better. This also happens in a diaper, where urine is turned into a gel by a superabsorbent polymer. This polymer powder can absorb up to 300 times its weight and mask the urine odor (Hammack, 2016). However, using absorbent pellets instead of powder (Figure 45) is more convenient in use (Absorbent Pellets, n.d.). Jellified urine does create a lot of waste.

#### 2 Catheter bag



**Figure 46** 2L catheter drainage bag.

The second option is to use a catheter bag, which is also available with a 2L storage volume. The flexibility of the bag allows it to expand while being filled up with urine. The bag does not need an opening to let the air out, therefore the urine can be stored as a liquid. Storing urine as a liquid makes the disposal easier and creates less waste. Catheter bag are cleanable and can be reused between two weeks and up to a month (Walker, 2015). To attach the drainage bag to the wheelchair a fabric cover can be used, which will help in maintaining the freedom of movement.

*Catheter bags are the option that creates less waste because there is no need to use an absorbent material. This will make it easier to use for the caretakers because this is familiar to them. The attachment to the wheelchair can easily be changed depending on the type of wheelchair of the user.*

### 3.3 Product usage and care

The product usage for the user is fairly self-explanatory. However, the placement and care for the product, done by the caregiver, could use some explanation.

#### 3.3.1 Product placement and removal

The placement of the product is not difficult because of the opening in the topdeck foam. The most logical order is:

1. Pull the tube through the back of the seat
2. Connect the tube to the product (barb fitting)
3. Place the product into the recess
4. Place the toplayer over the product and seat
5. Connect the drainage bag to the tube and place inside the box/cover (which is connected to the wheelchair)

After the product installment, the user can transfer into their wheelchair. Since part of the product is sticking out, this might require some practice. The client indicated that it would be practical to be able to slide over the product out of the chair. With the current shape, this will deform the curve, as shown in Figure 47. The deformation is not really controllable. This is not necessarily a bad thing, because silicone will return to its original form. But it could be uncomfortable for the user. Therefore a “crumple zone” is added to the prototype that will be tested by the user (Chapter 4). This idea is based upon a bendable straw, which should result in a controllable deformation of the product. Adding this might improve comfort during the transfer in and out of the chair, but practice must show whether this principle works in this context.

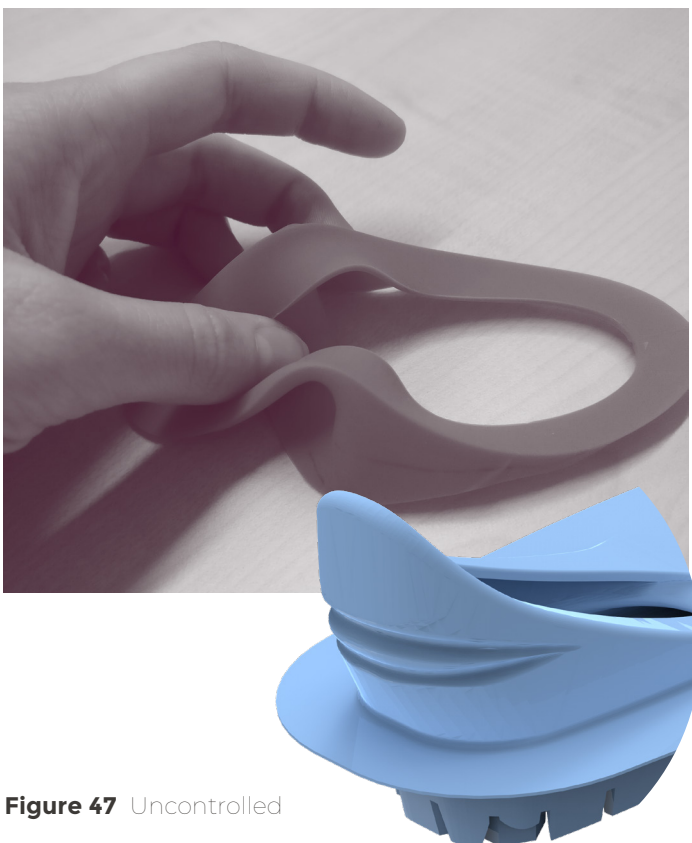

Figure 47 Uncontrolled

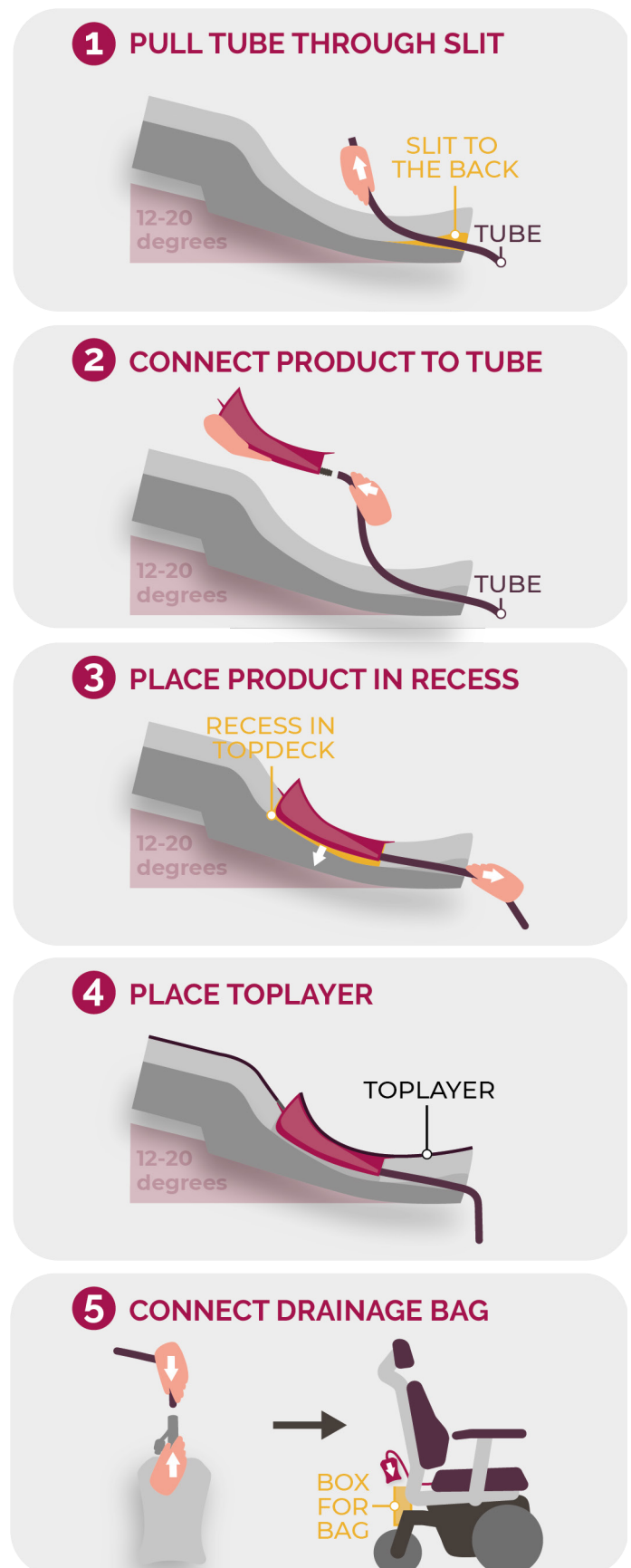

Figure 48 Product placement steps.



### 3.3.2 Product placement and removal

Cleaning the product at the end of the day could happen in the following order. But ultimately, the caregiver can best indicate how the product should be cleaned. Depending on regulations, parts like the tubing and container might need to be replaced every week or month (Walker, 2015). The assumed cleaning and product care steps are also shown in Figure 49.

1. Remove and wash the fabric toplayer. Spacer fabric has a maximum washing temperature of 60 degrees.
2. Emptying the drainage bag and disposing of the urine. The drainage bag can be cleaned using chlorine diluted with water (a least every other day) (Walker, 2015).
3. Placing a container or bucket under the tube and flush soapy water through the product and the tube. This can be done while leaving the product placed inside the seat.
4. Let the parts air dry before reassembling. Drying could be done over night.
5. Every two to four weeks the drainage bag and tubing should be replaced (Walker, 2015).

Figure 49 Product cleaning steps.

## 3.4 Conclusion

The final design, as a result of the embodiment phase, can be seen in Figure 50 on the next page. This design will capture the urine closely to the body to then drain it to the backside of the wheelchair using the angle of the wheelchair seat. Even though this solution requires an alteration to the wheelchair seat, it will provide enough benefits to the user to neglect this disadvantage. The product will function as a toileting solution that will last the whole day and prevents the user from unnecessarily having to leave their wheelchair. This provides the user with more freedom to go outdoors. The design moves away from the medical direction of the currently available products (catheter and diaper) and more towards an optional addition to the seat orthosis. The solution only adds a thin layer over the seat, keeping the ergonomic shape of the orthosis intact. This will lower the chance of discomfort. The soft silicone material will easily form to the user's body.

### Adaptation to the seat

The Lewis orthosis is made up of three parts, see figure. To fit the product inside the seat, alterations are needed. The seat cover and the topdeck foam need an opening based on the positioning of the product on the seat. When, after a period of use, the product needs to be repositioned these two layers can be replaced. The bottom of the seat orthosis, the foam seat (hard foam), provides comfort and stability to the users, guiding their body in the right posture. The aim was to minimize the alteration to this part of the seat because it would influence the performance of the orthosis. To ensure a good urine flow through the tube, a small slot is made to keep the tube straight. Because this is an uncritical area of the seat, this should not cause problems.

### The product

The product itself provides two main things to the user, comfort, and functionality. The comfort of the product will determine if the product is suitable for long-term (continuous) use. The product is made from medical grade silicone for safety and hygiene. To make it applicable for all females, the product should be available in multiple sizes. The sizes will vary based on body weight, width, and height. All the different parts of the product can be found in Figure 50.

### Implementation

The placement and location of the product is very important for its success. Together with the alteration required to the seat, this makes the product not suitable as an off the shelf product. The product is difficult to be measured and installed by the user herself. Therefore it is most logical that this product should become part of a manufacturer in wheelchair seats or orthosis. It could be a good addition to their product line. However further development and testing is needed before the product is ready.

### The product

The product partly sinks into the seat and partly sticks out. The curved top half will stick. The user will sit against the curve and urinate through the opening. The bottom half sinks into the seat. It has a thinner thickness than the topdeck. When the topdeck foam compresses the product will move downward. The angled position of the seat is used to drain the urine to the back of the wheelchair. A more detailed description is shown in Figure 51 on page 62.

### The seat cover

The seat cover will need an opening at the top and a hole at the back. The tube goes through the hole at the backside of the seat

### The topdeck layer

The topdeck foam that covers the seat will need an oval opening for the product as well as a slit for the tube. The most commonly used topdeck foam has a thickness of four centimeters (Luijten, personal contact, 2020). However, depending on the weight of the user, the less frequently used five-centimeter foam could be needed, giving more room for the product.

### The foam seat

Minimal alterations to the seat are required, to not change the performance of the seat. Only a small slit at the back is needed to keep the tube going straight for good urine flow. The seat is installed in a tilted position, which is used by the LooWee to drain the urine to the back of the wheelchair.

# The LooWee

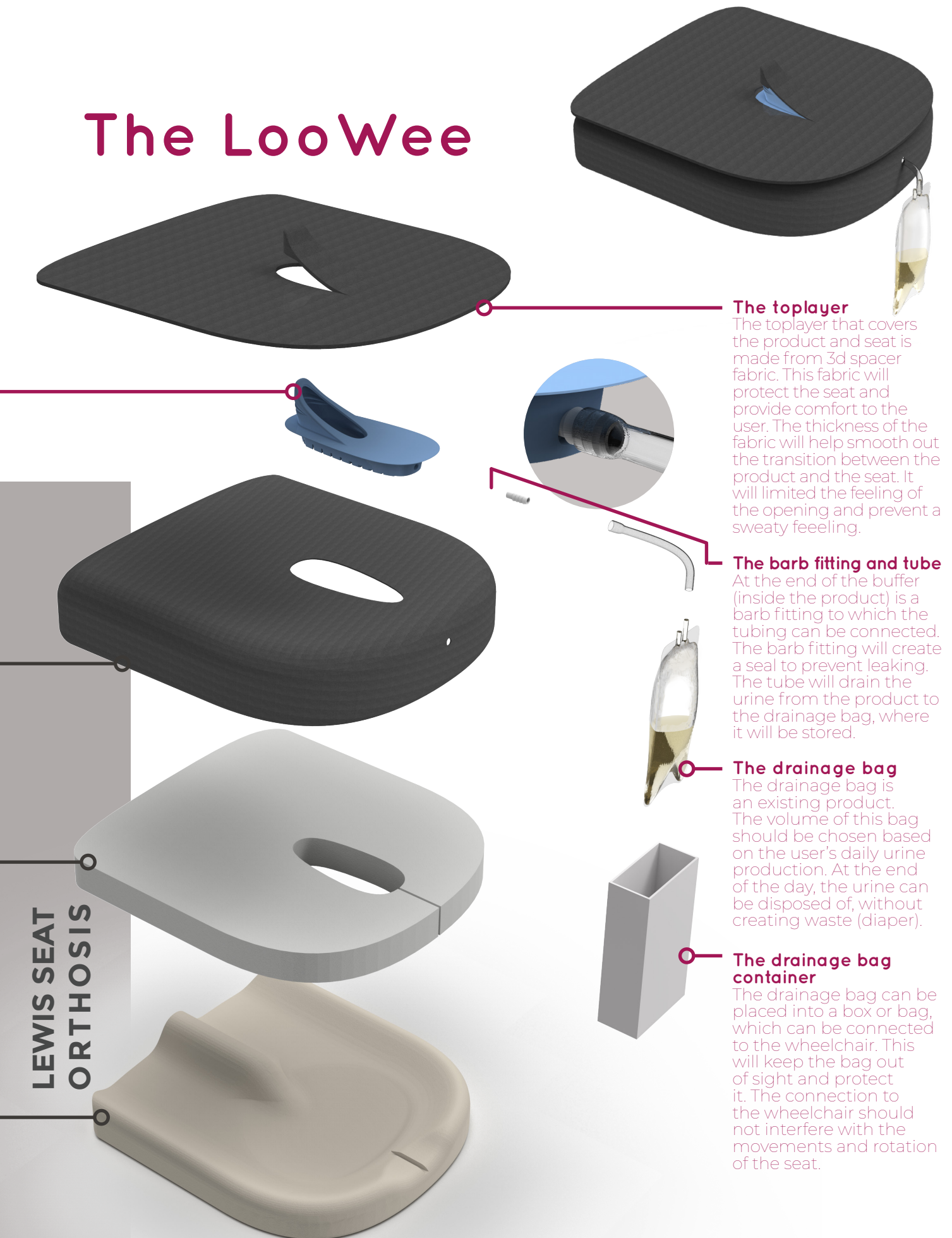

LEWIS SEAT  
ORTHOSIS

## The toplayer

The toplayer that covers the product and seat is made from 3d spacer fabric. This fabric will protect the seat and provide comfort to the user. The thickness of the fabric will help smooth out the transition between the product and the seat. It will limited the feeling of the opening and prevent a sweaty feeling.

## The barb fitting and tube

At the end of the buffer (inside the product) is a barb fitting to which the tubing can be connected. The barb fitting will create a seal to prevent leaking. The tube will drain the urine from the product to the drainage bag, where it will be stored.

## The drainage bag

The drainage bag is an existing product. The volume of this bag should be chosen based on the user's daily urine production. At the end of the day, the urine can be disposed of, without creating waste (diaper).

## The drainage bag container

The drainage bag can be placed into a box or bag, which can be connected to the wheelchair. This will keep the bag out of sight and protect it. The connection to the wheelchair should not interfere with the movements and rotation of the seat.

Figure 50 The final product, exploded view of the layers of the product

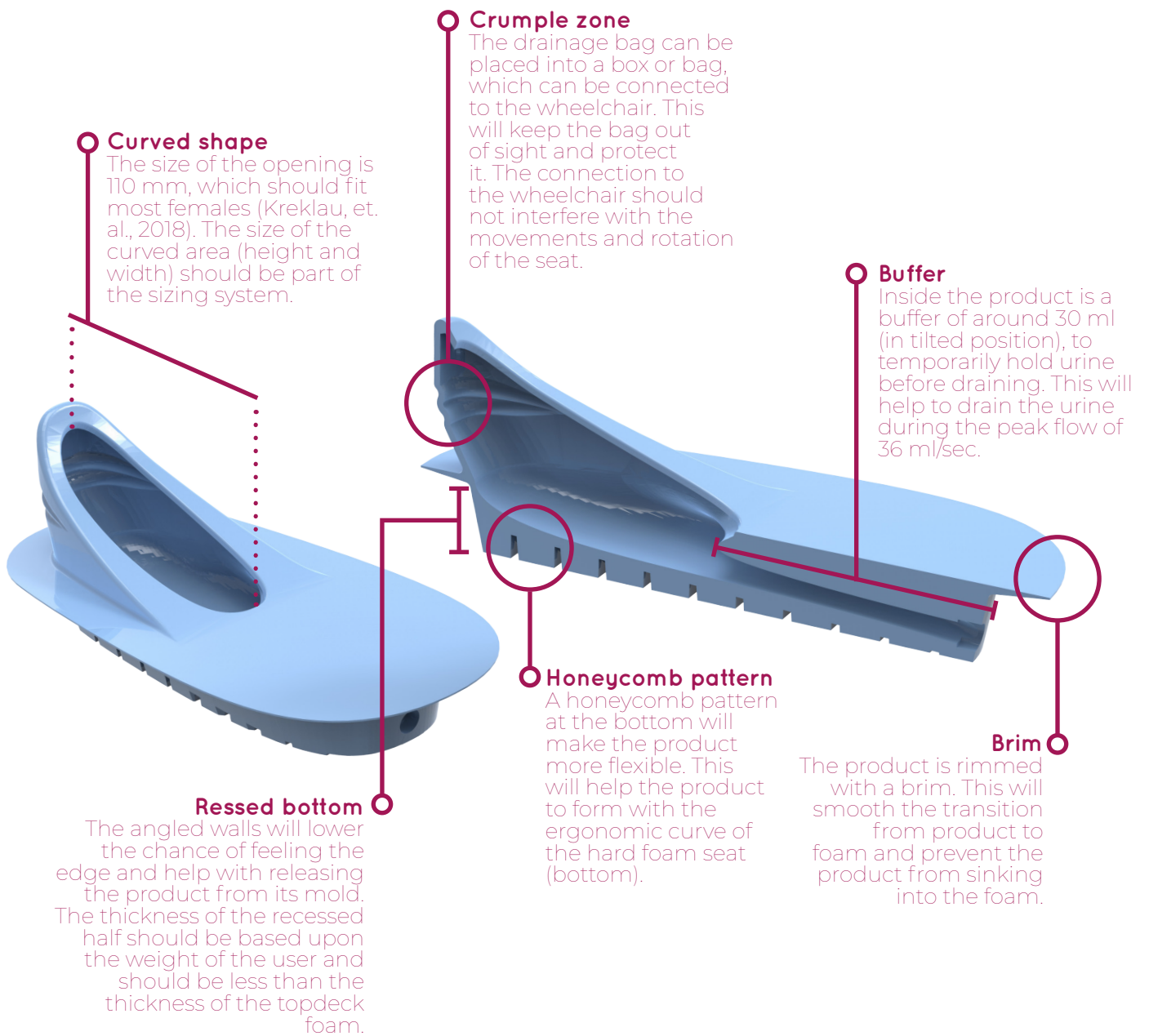

**Figure 51** Product specifics and details.



**Figure 52** Look of the product when installed into a seat.





# Evaluation

To verify the final design that was a result of the embodiment phase, an evaluation test was conducted. The main focus of this test was to check the sizing, comfort, and functioning of the product. A functional prototype was made to conduct the test, which was built into a Lewis seating orthosis. Because the sizing was indicated as large, a second smaller version was also modeled. This chapter will cover the following parts of the evaluation test: the prototype, the method, results, and conclusion.

The main goal of the test is to test the comfort of the product, The comfort will determine if it is suitable for long-time and daily use. This comfort test was conducted by the client. A separate functionality test was conducted to test the urine drainage of the design.

## 4.1 The prototype

To test the comfort of the product, two versions were modeled varying in size. After testing both sizes, the smaller size was chosen to use during the final evaluation. The total size of the product was too large to use additive manufacturing. Using 3D printing would result in an expensive prototype that was unequal to the original model. Consequently, silicone casting was chosen.

### 4.1.1 Silicone casting

To increase the casting success, the product was split into two parts that will be glued together afterward. To have a large area to connect the two halves, the product was split at the brim. The set-up of the molds can be seen in Figure 53, which shows the two-part mold (base and insert). The mold were printed on an Ultimaker 2+ with PLA filament. The silicone used was Dragon Skin Silicone Shore 10. The glue used to connect the two halves is the Sil-Poxy™, which was originally devised for attaching the fabric top layer. Sil-Poxy™ is also suitable for connecting and fixing silicone (Sil-Poxy™, n.d.). Both Dragon Skin and Sil-Poxy™ are skin safe.

A fabric slightly thinner than the previously tested fabric was used for the toplayer for the prototype. A cap was sewed into the toplayer, that can be hooked over the top of the curve (Figure 61). The edges were finished with a band as can be seen in Figure 61. The prototype was built into a Lewis seat orthosis provided by the client. The steps taken in to process of building the prototype are shown in Figure 54 till Figure 61.

### 4.1.2 Prototype limitations

The prototype was made from two halves that were glued together. This does result in a thicker brim than in the actual model. Enough thickness was needed to make it castable. This thickness at both halves creates a thicker brim than it should be. The two sides of the brim are glued together, which will cause the brim to wave when the product is bent (Figure 56). The thickness and waving of the brim could make it more perceivable than it should be. This is taken into account during the user test. Just as the thinner toplayer fabric.

The used Lewis orthosis was not the same as the seat currently used by the client. This seat was not as ergonomic in shape, which will result in a different pressure distribution on the seat. The seating experience will be different than what the client is used to.

### 4.1.3 Prototype cost

This user test will provide proof of concept, which will be the first stage of the product development. However, it is expected that the design will still require research and testing before it is production-ready. Therefore it is difficult to calculate a cost price for the product. However, the material costs for one prototype (as listed in Table 8) can give an estimation for the material costs (excluding production and mold cost).

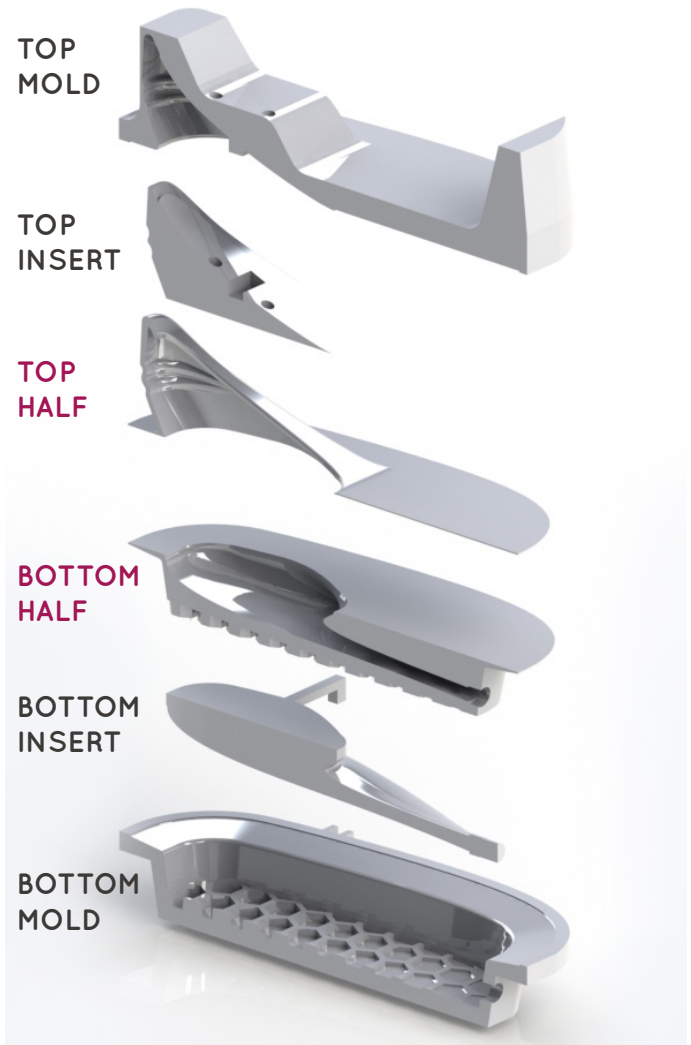

**Figure 53** Exploded view of the set-up of the prototype making.

<b>Silicone</b>	€ 15,-
<b>Spacer fabric</b>	€ 9,- (18 per meter)
<b>Barb fitting</b>	€ 0,90
<b>Tubing</b>	€ 0,70 (per meter)
<b>Catheter bag</b>	€ 5,-
	<b>€ 30,60</b>

**Table 8** Material costs for one LooWee prototype.



**Figure 54** Preparing the molds



**Figure 55** Pouring the silicone

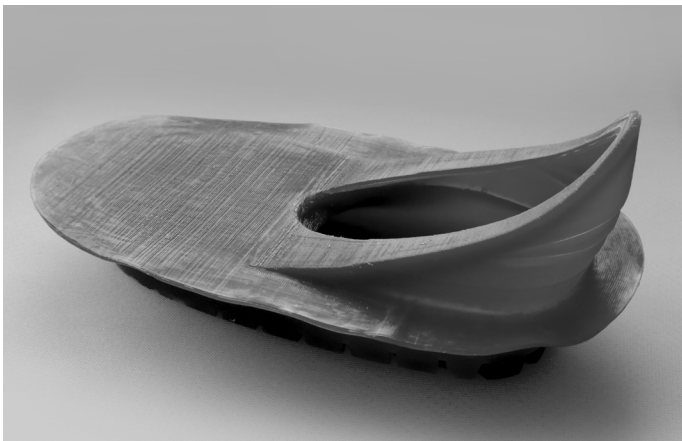

**Figure 56** Two halves glued together, slight wave in the brim



**Figure 57** Cutting the opening in the topdeck layer.



**Figure 58** Reassembling the seat.



**Figure 59** Pulling the tube through and attaching to product



**Figure 60** LooWee placed inside the seat



**Figure 61** Putting the toplayer over the seat, with a cap to attach to curve.

## 4.2 Method

### 4.2.1 Comfort test

The main goal of the comfort test was to validate the assumptions made regarding the comfort of the LooWee. As a result, points of improvement were found, which can be input for further development of the product. The test was conducted by the client and consisted of three parts: preparations, testing and evaluating. An more elaborate method description can be found in Appendix 14.

#### PREPARATIONS

The altered seat was mounted to the wheelchair of the client. The placement of the LooWee on the seat was estimated (figure). This location should be tested and changed if needed. To change the location of the LooWee, the topdeck layer needs to be changed. This step will provide information about the ease or difficulty of finding the right location.

#### TESTING THE COMFORT

Once the product is located in the right space the comfort could be tested. The client was asked to sit on the prototype as long as comfortable while paying attention to three areas: the edge of the brim, the curved area, and the area on which you sit. The client was asked to rate these three areas multiple times (amount would be dependant on the duration of the test). The rating of the three areas could indicate a change in discomfort. If discomfort increases this could be a potential problem when the product is used for a whole day.

#### EVALUATION

After the comfort test, the client was asked to answer multiple questions regarding the comfort, the ease of use, and experience. The list of questions can be found in appendix 14. To get more in-depth insights, afterward the test the client was called in order the further discuss the results of the test.

### 4.2.2 Functionality test

The functionality of the product was tested separately from the comfort test. Due to the results of the comfort test the client could not test the functionality of the product. The functionality was done in the test set-up shown in Figure 63. The test was conducted with and without the toplayer over the product. Because there was no Lewis orthosis available during this test, a simulated seat was made with an angled stool and foam layer. To come as close to the normal scenario.

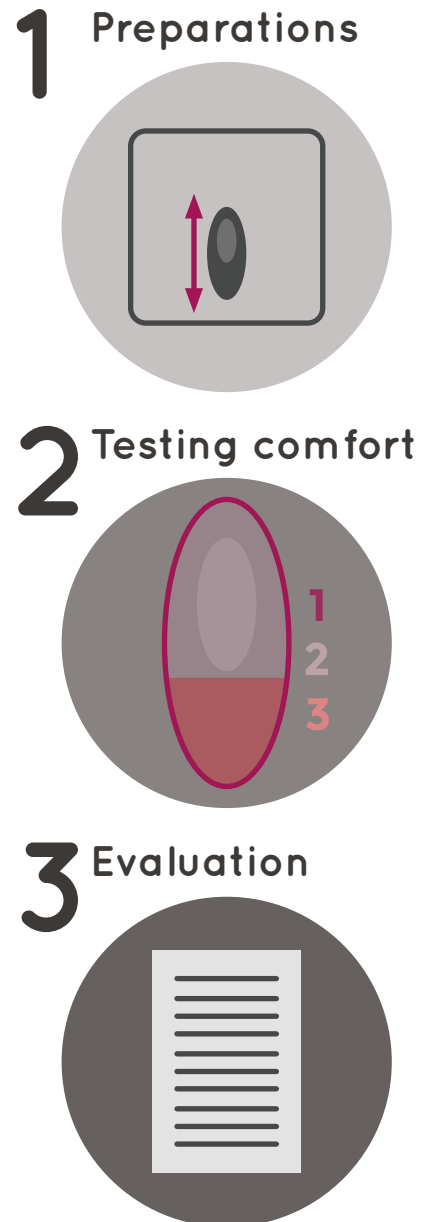

Figure 62 Three steps in the comfort test.

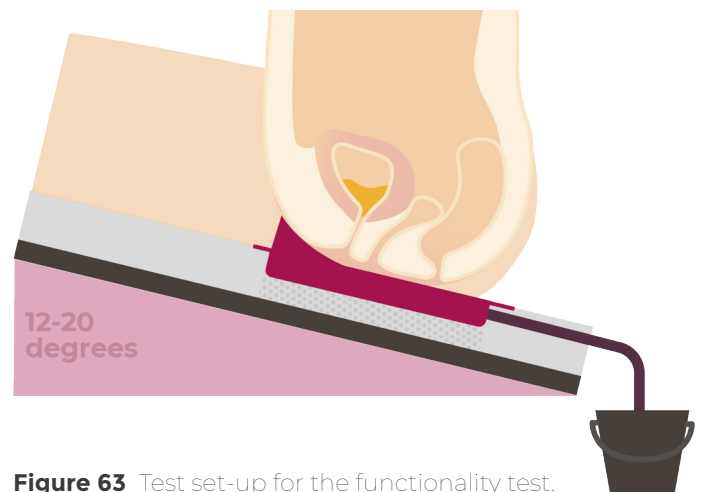

Figure 63 Test set-up for the functionality test.

## 4.3 Results + Conclusion

### 4.3.1 Comfort test

#### RESULTS

Only the first half of the comfort test was conducted by the client. Due to the seat used for the prototype, it was not possible to attach it properly to the client's wheelchair. However, the short time spent on the prototype did give results about the comfort of the product.

Finding the right location was difficult to do. Transferring in and out of the wheelchair was not a good way to go about it, because it was experienced as exhausting. During the transfer in the seat, the toplayer would not stay in place. It would detach from the curve and it was not possible to reattach it while seated. Because the toplayer moved so freely, it was hard to get in a comfortable position. The curved part, which is the biggest change to the seat surface, was not experienced as unpleasant. The client expressed that the soft material gave her the feeling the curve could stay comfortable throughout the day. The part that had the opposite experience was the edge of the product (Figure 62). The edge was immediately feelable and the toplayer did not help in smoothing out the edge.

#### CONCLUSION

The difficulty in finding the right position was partly because the seat was not properly attached. However, it does show that this is difficult to do by the user herself (even with help). This fits the assumption that the product should be placed by an expert (chapter 3.1.3). The client suggested using the pressure distribution images that were made for measuring her seat. This distribution map could help locate with more precision. This would prevent doing it through trial and error.

The client's main concern after use was the edge of the product, which was immediately noticed. This could be a result of the limitation discussed in chapter 4.1.2. The extra thickness of the brim and the thin toplayer could have resulted in the fast notice of the edge. However, because it was noticed so quickly it is a point of concern. A suggestion was to further sink the product into the seat, instead of hanging it on top of the foam.

Lastly, there was the toplayer, which was not secured enough. It was able to move too freely, preventing the client from getting comfortable. The fabric had a very smooth texture that could have made it move easily. The toplayer should be better fixed to the seat to prevent movement, to make it possible to shift in the seat. Shifting in the seat is necessary to get in a comfortable position during the transfer. However, it should still be removable for cleaning. To provide more protection to the seat she also suggested a second layer that would be water repellent.

### 4.3.1 Functionality test

#### RESULTS

The functionality of the product was tested with and without the toplayer. The results for these two setups were very different.

The first test was done without the toplayer. During urination, there was no spilling or leakage outside of the product. The participant had the feeling of urinating inside an opening, which gave a sense of control. And she felt that the urine drained fast enough. However, this way of urination was unfamiliar and it was mentioned that urination behavior was slightly changed. Because of the lack of experience with the product, the participant urinated more slowly than usual. When the urine drainage stopped the participant got up, which resulted in more urine coming out of the tube. Suggesting that some urine was trapped inside. Testing the product with the toplayer did not have the expected result. Part of the urine did not get drained but flowed backward. The toplayer made the participant feel less in control compared to the first test. She wasn't immediately aware that something went wrong.

#### CONCLUSION

The of the functionality test were very clear. The toplayer did not have the desired and expected effect during use. The participant mentioned that she urinated more slowly than usual. The previously done fabric material test likely used a higher speed (max urine speed, Appendix 7, which could have resulted in these different results. However, these results raise the question of whether or not the toplayers should cover the opening. Because it was mentioned that the toplayer lowered the experience of control during urination.

Unfamiliarity with the product does cause a change in urination behavior, but mostly due to the lack of experience using the product. It can be expected that it will take some time to get familiar with the product. It will require trust in the product to urinate naturally. But to gain trust the product should function without spilling or leaking.

An unexpected result was the small amount of trapped urine during the first test. This suggests that the pressure on the product from sitting resulted in a deformation of the product. Because a flat surface was used instead of an orthosis, this could have resulted in high-pressure points at the critical areas (chapter 1.1.1, Figure 6). A high-pressure point at the tailbone could have been the cause. However, it is unclear whether or not an orthosis can prevent this from happening.

The main conclusion of this test was that the functionality is best when the toplayer is not used.

# Conclusion

The goal of this master thesis was to design a new toileting solution for female powered-wheelchair users. This target group is not able to (easily) transfer in and out of their wheelchair, making going to the toilet a difficult task. The currently available options are adult diapers or a catheter. Both are medical tools for a medical problem that the user does not (necessarily) have. Not only are diapers and catheters medically unnecessary, they are also uncomfortable or sometimes even painful. Users become dependant on caregivers and are limited in their mobility because they cannot leave their house for long periods. Altogether, this has a large impact on their quality of life.

This thesis aimed to design a new urination tool that could help female powered-wheelchair users, and which can be used while staying seated. The product should last the whole day, without causing discomfort. The chosen concept was developed, focussing on the comfort, functionality, and hygiene of the concept. These areas will determine whether or not the concept would meet the requirements, and therefore solve the problem. The result of this master thesis is the LooWee, a product that is incorporated into the wheelchair seat (orthosis). It makes use of the tilted position to drain the urine away to the back of the wheelchair. A prototype was made to test this principle (function) and evaluate the comfort.

## COMFORT + EXPERIENCE

The comfort was mainly related to the shape and material of the LooWee. The soft silicone was experienced as pleasant, forming easily to the body without causing high-pressure points. Even though the curve is perceivable, it is not unpleasant. This is important because the concept principle is based upon the curved shape. Without it, the concept would not function.

The evaluation resulted in two main concerns regarding the comfort of the LooWee. These two areas were the product edge (brim) and toplayer. The toplayer was expected to improve the comfort, by smoothing out the edges and covering the opening of the silicone curve. However, in practice, the toplayer did not perform as expected. It easily detached and shifted around, making it difficult to get comfortable on the seat. It did not mask the edge of the brim. And most importantly, it did not properly let the urine through. Evaluating the comfort test with the client resulted in the thought that the way the silicone part is placed into the seat is not suitable. Changing the shape and placement method of the LooWee could potentially lower the number of edges.

## FUNCTIONALITY

The functionality of the LooWee mainly concerns the urine drainage from the silicone part towards the drainage bag. The functionality was tested to validate if this principle works. But again the toplayer did not function as expected. The simulated effects of the fabric (material test) did not match with what happened in practice. The toplayer prevented the urine from reaching the opening and instead landed on the seat. However, testing the functionality without the toplayer did give positive results. It showed that the principle did work. Urination through the opening (in a tilted position) did drain the urine without leaking. Both comfort and functionality tests showed the need to change the toplayer.

## HYGIENE

All parts of the LooWee can be detached and cleaned or replaced to keep it hygienic. However, in the current prototype, the LooWee will not meet the main hygiene requirement: The product may not leak urine. The urine leakage, caused by the toplayer, being the main problem.

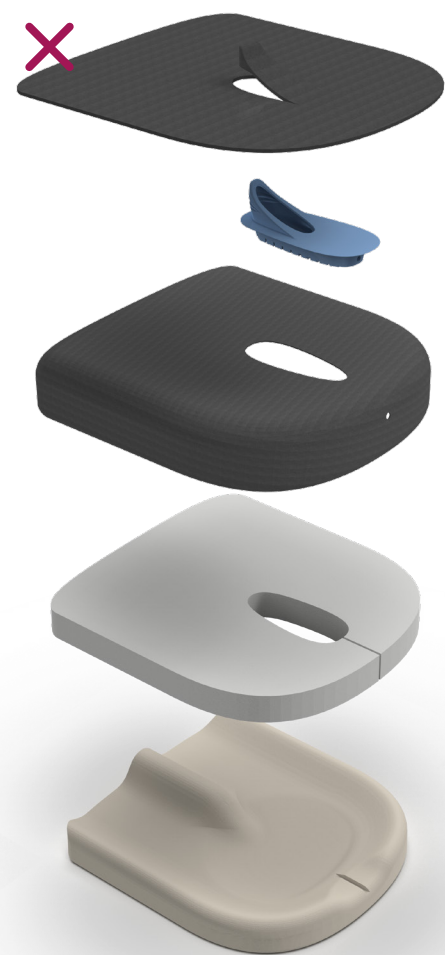

Figure 64 Layers of the LooWee.

**The main conclusion of this thesis is that, when excluding the toplayer, the principle of the LooWee works. Urination through the opening can capture the urine directly at the urethra and therefore is able to control the unpredictability of the female**

**urine stream. However, in the current design, the toplayer is the cause of many problems. Both toplayer and comfort require more research and testing to make the product functional in total.**

# Recommendations

*The conclusion of this master thesis revealed multiple aspects of the LooWee did not meet the requirements and require improvement. The parts that need improvement are the toplayer, the brim (product shape), and finding the location of the product. For each part, recommendations are given that could help in the next stage of product development.*

## **THE TOPLAYER**

Further research and development of the toplayer are needed. The evaluation suggested that the toplayer should not cover the opening, as it would obstruct the urine flow and cause spillage. However, the toplayer helped prevent a sweaty feeling of sitting on a silicone product and protect the seat. Therefore, completely removing it is not an option. An option could be to make an opening in the fabric at the location of the opening. The toplayer has a cap that hooks over the curve. The client mentioned that, during the comfort test, the cap did not stay in place. When a user makes the transfer into their wheelchair, it will require some shifting to get comfortable. During which, the toplayer should stay in place. It is advisable to let a seamstress look into creating a proper pattern for the toplayer. The number of seams should be minimized and should not cause any pressure injuries. The client also suggested that an extra waterproof layer could be placed under the toplayer to protect the orthosis.

## **THE BRIM AND PRODUCT SHAPE**

The client mentioned that the edge of the brim was immediately noticeable. Currently, the product is hanging on top of the seat. The brim is used to stay level with the top surface of the seat and prevents the product from sinking into the foam. The client suggested the idea to change the way the product is incorporated into the seat. Placing the product under the topdeck foam would remove the brim and potentially improve the comfort. Only the curved shape would be sticking out from the seat. However, it would require changing the shape of the product. Further research and testing are needed to find the most fitting shape.

During the development of the shape, the sizing system can be further researched as well. As mentioned in chapter 3.1.2, a sizing system is assumed to be needed to fit the different weights and sizes of users. Due to time limitations, this was not yet developed. Further research is needed to find the right variables for the size system as well as the actual sizes.

More testing is needed to give results about the comfort of the product. Because the user is sitting statically in the wheelchair during the day, the product should also stay comfortable for this duration. To get a good view of the product comfort, longer tests are needed. Longer tests will be able to tell if the product is suitable for long term daily use. Areas can increase in discomfort over time and in the long run cause issues. Longer testing will also show the areas that can potentially cause pressure injuries. Which in return can be improved again.

## **LOCATION ON THE SEAT**

The location of the product on the seat is personal per user. A measurement procedure is needed to find the right position. During the comfort test, the client was required to find this position herself. However, finding the location through trial and error is not suitable for the target group. It requires multiple transfers in and out of the wheelchair, which is both time-consuming and tiring. During the measuring process of the Lewis orthosis, the pressure distribution on the seat is measured. This pressure map could be used to find the location for the product. Additionally, using the map would help to place the product outside of the critical areas.

## **FURTHER DEVELOPMENT**

The main focus of this thesis was on product comfort and urine drainage. Therefore some parts of the concept were not very far developed. This mostly concerns the part regarding the storage of the urine. One element is the bag/box in which the catheter bag can be placed. This will be connected to the wheelchair. As discussed with the client, a fabric bag would be the most suitable solution. When developing this bag, it should be made attachable to different types of wheelchairs. It should not interfere with the movements of the wheelchair. The drainage test showed that the tubing needs to have an inside diameter of at least 8 mm. Looking into the connection between the tubing and the drainage bag should tell if this is possible with an available tubing connector.

# References

- 3D Printing in Silicone: SLA: 3D Print Service. (n.d.). *Beamler*. Retrieved from <https://www.beamler.com/3d-printing-capabilities/materials/silicone/>
- 66 procent van mindervalidentoiletten ontoegankelijk en onbruikbaar (2014, October 12). *Nederlands Instituut voor Toegankelijkheid*. Retrieved from <https://nederlands-instituut-voor-toegankelijkheid.nl/2014/08/12/66-procent-van-mindervalidentoiletten-ontoegankelijk-en-onbruikbaar/>
- Absorbent Pellets. (n.d.). *Recyc PHP Inc*. Retrieved from <https://recycphp.com/en/p/finished-goods/absorbent-pellets/>
- Annet (2005, September 22). *Een dagje weg en dan moet je naar het toilet (vrouw)*. [Online Forum Post]. Message posted to <https://myocafe.spierziekten.nl/gesprek/een-dagje-weg-en-dan-moet-je-naar-het-toilet-vrouw?sortOrder=desc>
- Annet. (2014, march 5). *BLAASCATHETER*. [Online Forum Post]. Message posted to <https://myocafe.spierziekten.nl/gesprek/blaascatheter-0?sortOrder=desc>
- Anthropometric database. (n.d.). *DINED*. Retrieved from <https://dined.io.tudelft.nl/en/database/tool>
- Berry, J. (2017, September 25). *Suprapubic catheters: Uses, care, and what to expect*. Retrieved from <https://www.medicalnewstoday.com/articles/319523#risks-and-benefits-of-suprapubic-catheters>
- Bubbert, A. H. F. (2018, November 9). *U kunt hier niet naar de wc*. Retrieved from <https://www.oneworld.nl/achtergrond/u-kunt-hier-niet-naar-de-wc/>
- Chantal (2010, oktober 11). *TOILETGANG*. [Online Forum Post]. Message posted to <https://myocafe.spierziekten.nl/gesprek/toiletgang>
- Characteristics properties of Silicone rubber compounds. (2016). *Shin-Etsu*. [PDF] Retrieved from [https://www.shinetsusilicone-global.com/catalog/pdf/rubber\\_e.pdf](https://www.shinetsusilicone-global.com/catalog/pdf/rubber_e.pdf)
- Cijfers meldingen verpleeghuiszorg en thuiszorg (2019, September 6). *Volksgesondheid*. Retrieved from <https://www.igj.nl/over-ons/igj-in-cijfers/cijfers-over-meldingen/cijfers-meldingen-verpleeghuiszorg-en-thuiszorg>
- Davies, A., Souza, L. H. D., & Frank, A. O. (2003). *Changes in the quality of life in severely disabled people following provision of powered indoor/outdoor chairs*. *Disability and Rehabilitation*, 25(6), 286–290.
- Doorligwond (decubitus). (n.d.). *Maasstadziekenhuis*. Retrieved from <https://www.maasstadziekenhuis.nl/aandoeningen-ziektebeelden/aandoeningen/doorligwond-decubitus>
- Durometer Conversion Chart. (n.d.) *Mechanical Rubber*. [PDF]. Retrieved from <https://www.mechanicalrubber.com/elastomericsolutions/wp-content/uploads/2013/08/Durometer-Conversion-Table.pdf>
- Endsjo, A. (2018, November 29). *Offloading vs Immersion: Wheelchair Cushions for Pressure Injuries*. Retrieved from <https://hub.permobil.com/blog/offloading-vs-immersion-wheelchair-cushions-for-pressure-injuries>
- Gaskell, E. T. (n.d.). *Overall Results of FUD Testing*. Retrieved from <https://www.mediamatic.net/en/page/232100/overall-results-of-fud-testing>
- Gezondheidsmonitor; bevolking 19 jaar of ouder, regio, 2016. (2018, November 22). *CBS*. Retrieved from <https://opendata.cbs.nl/statline/#/CBS/nl/dataset/83674NED/table?ts=1572341481637>
- Hammack, B. [engineerguy]. (2016, June 14). *The Engineering of a Disposable Diaper*. [video file]. Retrieved from <https://www.youtube.com/watch?v=xYNX8y6lQMc>
- Hanneke voor Anne (2009, augustus 5) *KATHETERISEREN VIA NAVEL*. [Online Forum Post]. Message posted to <https://myocafe.spierziekten.nl/gesprek/katheteriseren-via-avel>
- Hoppenbrouwer, W. (2019) *Anatomisch Verantwoord en Stabiel zitten*. [Powerpoint slides].
- Henry. (2012, november 7) *NAAR HET TOILET GAAN ONDERWEG*. [Online Forum Post]. Message posted to <https://myocafe.spierziekten.nl/gesprek/naar-het-toilet-gaan-onderweg>
- Jeanine. (2006, oktober 31). *WIE HEEFT ERVARING MET EEN BUIKKATHETER*. [Online Forum Post]. Message posted to <https://myocafe.spierziekten.nl/gesprek/wie-heeft-ervaring-me-een-buikkatheter>
- Jewell, T. (2019, November 25). *Suprapubic Catheter: Insertion, Procedure, and Complications*. Retrieved from <https://www.healthline.com/health/suprapubic-catheter#insertion>
- Johnson, J. (2018, April 5). *Holding pee: Is it safe?* Retrieved from <https://www.medicalnewstoday.com/articles/321408.php>
- Karin (2005, november 20). *INCONTINENTIE*. [Online Forum Post]. Message posted to <https://myocafe.spierziekten.nl/gesprek/incontinentie>
- Klerk, de, M., Fernee, H., Woittiez, I., Ras, M. (2012, July 27). *Factsheet: Mensen met lichamelijke of verstandelijke beperkingen*. *Sociaal en Cultureel Planbureau*. Retrieved from [https://www.scp.nl/Publicaties/Alle\\_publicaties/Publicaties\\_2012/Factsheet\\_Mensen\\_met\\_lichamelijke\\_of\\_verstandelijke\\_beperkingen](https://www.scp.nl/Publicaties/Alle_publicaties/Publicaties_2012/Factsheet_Mensen_met_lichamelijke_of_verstandelijke_beperkingen)
- Krekla, A., Vâz, I., Oehme, F., Strub, F., Brechbühl, R., Christmann, C., & Günther, A. (2018). *Measurements of a "normal vulva" in women aged 15-84: a cross-sectional prospective single-centre study*. *BJOG: An International Journal of Obstetrics & Gynaecology*, 125(13), 1656–1661. doi:10.1111/1471-0528.15387
- Leo. (2010, oktober 12). *TOILETGANG*. [Online Forum Post]. Message posted to



<https://myocafe.spierziekten.nl/gesprek/toiletgang>

Lewis Seating. (2019, november 26). *Dummy 4853*. (DOB-204853 - Dummy 'Prefab'). [Technical drawing]. Retrieved from M. Luijten.

Lithiumpje. (2012, augustus 14) *NAAR HET TOILET GAAN ONDERWEG*. [Online Forum Post]. Message posted to <https://myocafe.spierziekten.nl/gesprek/naar-het-toilet-gaan-onderweg>

MATERIAL DATA SHEET (2019). *Fromlabs*. Retrieved from <https://archive-media.formlabs.com/upload/Elastic-DataSheet.pdf>

Molnár, h. (2002, September 8). *Op pad met rollator, duwrolstoel en booster: Aangepast vervoer*. Centraal Bureau voor Statistiek.

O'Keefe Osborn, C. (n.d.). *What Does It Mean to Have a "Fat Vagina"?* Healthline. Retrieved February 28, 2020, from <https://www.healthline.com/health/womens-health/fat-vagina#talk-to-a-doctor>

Openbare toiletten ramp voor rolstoelers. (2015, November 4). *Dagblad van het Noorden*. Retrieved from <https://www.dvhn.nl/drenthe/Openbare-toiletten-ramp-voor-rolstoelers-21065372.html>

Over Ottobock. (n.d.). *Ottobock*. Retrieved from <https://www.ottobock.nl/informatie/>

'Personeelstekort in thuiszorg is onveilig en onverantwoord'. (2018, August 13). *NU.nl*. Retrieved from <https://www.nu.nl/economie/5408402/personeelstekort-in-thuiszorg-onveilig-en-onverantwoord.html>

Permobil. (n.d.). *General Product Information*. Retrieved from <http://www.permobil.com/en/Corporate/Products/Products/Our-Products/>

Pessoa, R., & Kim, F. J. (2018). *Urodynamics and Voiding Dysfunction*. *Abernathy's Surgical Secrets*, 452–454. doi:10.1016/b978-0-323-47873-1.00103-0

Plastics for Medical Use. (2015, August 14). *Colorado Plastics*. Retrieved from <https://coloradoplastics.com/plastics-for-medical-use/>

Qin, Y. (2016). *Applications of advanced technologies in the development of functional medical textile materials*. *Medical Textile Materials*, 55–70. doi:10.1016/b978-0-08-100618-4.00005-4

Rahimi, A., & Mashak, A. (2013). *Review on rubbers in medicine: natural, silicone and polyurethane rubbers*. *Plastics, Rubber and Composites*, 42(6), 223–230.

Ryan, F. (2018, August 6). *'It's horrifically painful': the disabled women forced into unnecessary surgery*. Retrieved from <https://www.theguardian.com/society/2018/aug/06/disabled-women-surgery-catheter-accessible-toilets>

Stenberg, G., Henje, C., Levi, R., & Lindström, M. (2014). *Living with an electric wheelchair – the user perspective*. *Disability and Rehabilitation: Assistive Technology*, 11(5), 385–394.

Silicone & Urethane Casting (n.d.). *RapidMade*. Retrieved from <https://www.rapidmade.com/silicone-and-urethane-casting>

Sil-Poxy™, Silicone Adhesive. (n.d.). *Smooth-on*. Retrieved from <https://www.smooth-on.com/product-line/sil-poxy/>

Singer, A. J., Richman, P. B., Kowalska, A., & Thode, H. C. (1999). *Comparison of patient and practitioner assessments of pain from commonly performed emergency department procedures*. *Annals of Emergency Medicine*, 33(6), 652–658.

Smulders, M., Berghman, K., Koenraads, M., Kane, J. A., Krishna, K., Carter, T. K., & Schultheis, U. (2016). *Comfort and pressure distribution in a human contour shaped aircraft seat (developed with 3D scans of the human body)*. *Work*, 54(4), 925–940.

Sylvia. (2012, July 26) *NAAR HET TOILET GAAN ONDERWEG*. [Online Forum Post]. Message posted to <https://myocafe.spierziekten.nl/gesprek/naar-het-toilet-gaan-onderweg>

Suprapubic Catheter. (n.d.). *Bladder and Bowel Community*. Retrieved from <https://www.bladderandbowel.org/surgical-treatment/suprapubic-catheter/>

Toezicht op de Zorg Thuis 2.0. (2019, februari). *De Inspectie Gezondheidszorg en Jeugd*. [PDF] Retrieved from <https://www.igj.nl/zorgsectoren/zorg-thuis/toetsingskaders>

Vink, P., & Hallbeck, S. (2012). *Editorial: Comfort and discomfort studies demonstrate the need for a new model*. *Applied Ergonomics*, 43(2), 271–276.

Walker, T. (2015, April 28). *Care of Reuseable Urinary Drainage Systems*. [pdf] Retrieved from <http://www.med.umich.edu/llibr/urology/CareReusableUrinaryDrainageSystems.pdf>

Wein, A. J. (2004). *The 24-H Frequency-Volume Chart in Adults Reporting no Voiding Complaints: Defining Reference Values and Analysing Variables*. *Journal of Urology*, 172(6 Part 1), 2494–2494.

Wie zijn wij. (n.d.). *Lewis Seating Systems*. Retrieved from <https://www.lewisseatingsystems.nl/over-lewis/>

Williams, S. C. (2019, August 6). *BARB CONNECTORS IN DEPTH – DESIGN AND FUNCTION*. Retrieved from <https://www.industrialspec.com/about-us/blog/detail/barb-connectors-in-depth-design-and-function>

# Image references

Figure 3 <https://www.sunrisemedical.com.au/powered-wheelchairs/quickie/q700-up-m-standing-wheelchair#lg=1&slide=0>

Figure 6E <https://www.pressuresorecushions.com/products/roho-hybrid-elite-cushion-single-valve>

Figure 6E <https://www.jympillow.com/product/memory-foam-gel-seat-cushion-manufacturer/>

Figure 6E [https://hulpmiddelen.spierziekten.nl/hulpmiddelen/product/stimulite-kussen/?tx\\_alternetdevicemarket\\_D=show&cHash=21769ea3ff80a6b0a4100d94406e43f2](https://hulpmiddelen.spierziekten.nl/hulpmiddelen/product/stimulite-kussen/?tx_alternetdevicemarket_D=show&cHash=21769ea3ff80a6b0a4100d94406e43f2)

Figure 10 <https://www.continenceproductadvisor.org/products>

Figure 11 <https://labblog.uofmhealth.org/rounds/more-than-half-of-catheterized-hospital-patients-experience-complications>

Figure 34 <https://www.stonybrookmedicine.edu/southbayobgyn/news-blog/nfatLosingbellyfatservesmorethanjustaestheticpurposes>

Figure 42 [https://www.researchgate.net/figure/Various-spacer-material-3D-spacer-fabric-left-and-Colbond-Enkadrain-right-Image\\_fig3\\_322255623](https://www.researchgate.net/figure/Various-spacer-material-3D-spacer-fabric-left-and-Colbond-Enkadrain-right-Image_fig3_322255623)

Figure 45 [https://www.viata.nl/urinecontainer-24uururine-25liter-hulpmiddel-urinetest-1-stuks-nl?gclid=CjwKC-AjwkPX0BRBKEiwA7THxiPTNI28lkuRpK1O56SLtAlJl3fhKc-lwyVYL7RwkjRsvl-zgxGLDfRoC72AQAvD\\_BwE#Xp1p2cgzZPY](https://www.viata.nl/urinecontainer-24uururine-25liter-hulpmiddel-urinetest-1-stuks-nl?gclid=CjwKC-AjwkPX0BRBKEiwA7THxiPTNI28lkuRpK1O56SLtAlJl3fhKc-lwyVYL7RwkjRsvl-zgxGLDfRoC72AQAvD_BwE#Xp1p2cgzZPY)

Figure 46 [https://www.google.com/search?q=catheter+bag&sxsrf=ALeKk00I7MY4\\_Qi-57-1439QcV6dQjGzUA:1587366941654&source=Inms&tbm=isch&sa=X&ved=2ahUKewidrr3VuvboAhWSLewKHU\\_sCI0Q\\_ECAsQAw&biw=1920&bih=937#imgrc=J7CURAJ0ibs5AM](https://www.google.com/search?q=catheter+bag&sxsrf=ALeKk00I7MY4_Qi-57-1439QcV6dQjGzUA:1587366941654&source=Inms&tbm=isch&sa=X&ved=2ahUKewidrr3VuvboAhWSLewKHU_sCI0Q_ECAsQAw&biw=1920&bih=937#imgrc=J7CURAJ0ibs5AM)

Figure 65 <https://healthmanagement.org/products/view/urine-sample-container-3-l-uri-comfort-series-paramount-bed>

Figure 66 <http://www.intermobiel.com/article/1651/Invention-kussen>

Figure 67 <https://allurehnb.com/people-who-use-a-wheelchair/>

Table 5B <https://3dprintingzoom.com/2019/09/10/materialise-turns-into-first-to-supply-basf-tpu-materials-for-hp-multi-jet-fusion-3d-printing/>

Table 7 <https://www.amazon.com/Sil-Poxy-Silicone-Adhesive-Ounce-Tube/dp/B001RC1Y10>

# A p p e n d i x

- Appendix 1** Project brief
- Appendix 2** Uncommon products
- Appendix 3** Diaper functionality
- Appendix 4** User acceptance of the need for a product
- Appendix 5** Caregivers inspection and quality standards
- Appendix 6** Ideation - Morphologic chart
- Appendix 7** Material testing
- Appendix 8** The lewis Orthosis
- Appendix 9** Durometer conversion chart
- Appendix 10** Silicone flexibility and softness test
- Appendix 11** Scanning methods
- Appendix 12** Urinal devices duration test
- Appendix 13** Drainage test
- Appendix 14** Concept evaluation test

## Appendix 2 Uncommon products

*Besides mainstream products, there are also some alternative products on the market. However, most products still require arm function and are big and very visible. They also are very visible and bulky in appearance, which makes them very visible to outsiders, and therefore influences the identity.*

### URI-COMFORT

A very large solution that would still require arm function from the user or assistance. Because of the size it is not easily transportable.

*"I dived into it a few years ago to figure out what the solution is. I found it ... it's the Uri comfort from Emcart. A reservoir with motor (electric), a long hose with a receiver and that's it. Extremely easy if you can't get out of your chair, okay it's only for urine but this way I can go home for almost a whole day without a lift. I have put it in a beautiful purple travel trolley, which can also contain some cellulose dust pads. Against unfortunate leaking." (Hanya, 2012)*



Figure 65 Uri-Comfort

### INVENTION PILLOW

An air pillow with in the middle a pipe that can be used to urinate. The pipe can be placed when it's needed and would require arm function. The client explained that an air pillow is not suitable for all users. The air pillow could result in bad posture..

*"I permanently use the urinal pillow ... . Now I provide all of my pants with a zipper of 50 cm in each side seam ... . This way you can unzip the pants and fold them over on your lap." (Hanneke voor Anne, 2009)*



Figure 66 Urinal pillow

### GO PILOT

The go pilot is not specifically targeted at wheelchair users but marketed as a portable urination tool. However, the figure does show it as a suggestion for wheelchair users. Just like the others, it requires arm function. The look of the Go pilot makes it very visible because it is situated at the front of the chair. No reviews were found of people from the target group that used this product.



Figure 67 Go Pilot

## Appendix 3 Diaper functionality

Diapers contain 4 layers that each contributes to the functionality of the diaper (Hammack, 2016). Below the functionality of each layer is explained. The figure visualizes the way the diaper absorbs the urine in 4 steps.

### TOPSHEET

This layer is made from polypropylene, a water repellent material. However, urine has enough speed to go through the fibers or the material (step 1). Once the urine reaches the surge layer and absorbent core it is no longer able to go up, therefore the user doesn't have a wet feeling (step 3).

### SURGE LAYER

The surge layer swells up when the urine enters this layer. This helps to distribute the urine over the length of the diaper until this layer is empty (step 2-3). The surge layer uses capillary action to achieve this, which also prevents urine from flowing back up.

### ABSORBENT CORE

The absorbent core consists of two materials: cotton and a superabsorbent polymer. The polymer absorbs the urine and turns it into a gel. The cotton helps to move the urine to unused areas (step 4). The more urine is stored the thicker the layer will become.

### OUTSIDE LAYER

It is made of plastic to keep the urine inside the diaper.

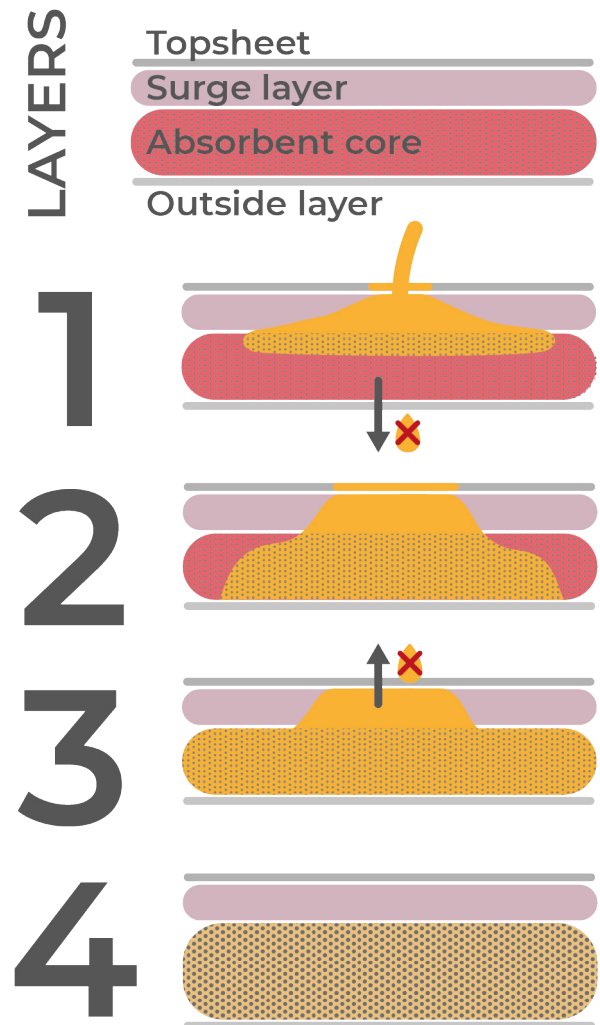

Figure 68 Layer and functionality of a diaper.

## Appendix 4 User acceptance of the need for a product

The way users deal with the realization of needing assistance and how they accept the urination tools is different per person. This appendix explores the user experiences that were found in articles and forums. It is divided into three steps: postponing assistance, accepting the need for a solution, and looking for alternatives. The colors of the quotes stand for the type of user they could belong to, which is described in chapter 1.2.1 The female electric wheelchair user.

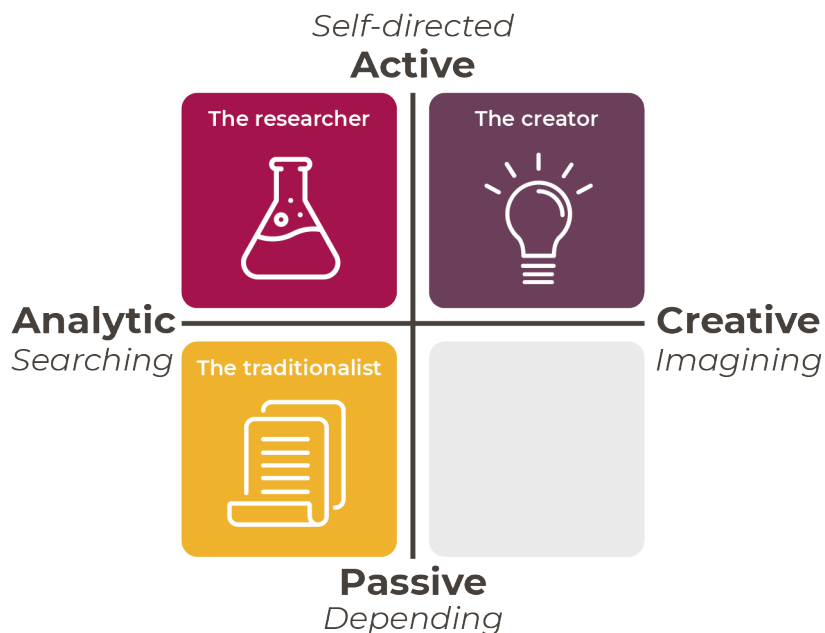

Figure 69 Three types of users.

### 1 Postponing assistance

Some women try to postpone the need for urination tools. Most try to solve their problem by preventing the need to go to the toilet. They start to regulate and limit their fluid intake and "hold it" when they are not at home. However, this can have consequences like headaches, low energy, sickness and sometimes even losing hair. In the long run, it could weaken the bladder muscles, resulting in incontinence. This approach cannot be sustained for long.

*"she has learned that the only way she can be out of the house from 9am to 5pm without needing the toilet is to limit her fluid intake to one and a half child-size cups per day." (Ryan, 2018)*

*"For years I have been holding in [urine] and drinking little has brought me large and many kidney stones." (Lithiumpje, 2012)*

*"Toileting was literally affecting every aspect of my life," (Ryan, 2018)*

### 2 Accepting the need for a solution

*Adult diaper* - The options on diapers are quite comparable. The main opinion about wearing a diaper is the difficulty of changing them. Many mentioned that disabled toilets are insufficient for this operation because they often don't have a changing table. Therefore, two caregivers are necessary to change a diaper in the small space of a public disabled toilet. Most users wear the diaper the whole day, giving them a wet and unclean feeling. Which is probably the result of the inaccessibility of public toilets (for changing) or the not having assistance during the day. Some users even mentioned they were embarrassed by wearing them.

*"Now [I'm] wearing a diaper during the day (how embarrassing ...)." (Jeanine, 2006)*

*"But I also think it's [diaper] not that fresh and it's not always comfortable, it also often leaks." (Mirnou, 2005)*

*"Now I almost always wear diapers (which is a disaster for me, every time I go to the toilet i'm depending on others)." (Karin, 2005)*

*"I felt humiliated having to ask my carers to put them [adult diapers] on me," (Ryan, 2018)*

*Catheter* - Were most users agreed on the negative sides of the adult diaper, the opinions on the catheter are very diverse sometimes even contradicting. Were some users are happy and content with there catheter, others find them painful and are happy once they are removed. The experience with the catheter is very dependent on the person. However, some users that find them painful or uncomfortable keep using them, because they can not find an alternative. Feeling that it is the only choice. In the quotes below the diversity in opinions are visible.

*"In itself, this [suprapubic catheter] is excellent, the regular bladder infection is something I make do with."* (Leo, 2010)

*"I have absolutely no problems with the catheter and would not want to be without it."* (Annet, 2014)

*"It [catheter] was the only choice, other than carrying on living with such restrictions [limiting water intake]."* (Ryan, 2018)

*"Your bladder recognises it as a foreign object and therefore constantly tries to expel it," ...The catheter is "by no means a fix-it solution". "But it's something I must endure, since the only alternative is to return to how I was before [limiting fluid intake]"* (Ryan, 2018)

*"I had a suprapubic [catheter] but it had to be removed again due to complications."*

### 3 Looking for alternatives

There are a couple of users that look for alternatives and take matters into your own hands. Most solutions entail altering clothing (adding zippers into pants etc.) and having some form of a urinal. While others use forums to ask other users for their solutions.

*" I use a specially made urinal (normal men's urinal with a long neck and a mouthpiece attached). I am pushed back in my chair and then my long pants, with long zippers on both sides, are opened and as well as my briefs which has a Velcro fastener in the crotch. "* (Sylvia, 2012)

*"I permanently use the urinal pillow ... . Now I provide all of my pants with a zipper of 50 cm in each side seam ... . This way you can unzip the pants and fold them over on your lap."* (Hanneke voor Anne, 2009)

*"Cut the crotch out of your pants so that only the front remains. You do not wear underpants, but sit on a fabric mat in the color of your wheelchair upholstery."* (Annet, 2005)

*"I heard about an abdominal catheter, but this is not an option for me because of the anesthesia. I have also tried the Invention cushion once, but this also does not work because I sit rather skewed [on it]. Does anyone have tips?"* (Sylvia, 2012)

*"We have already tried urinal and bedpan, but from the EPW that really does not work. I also tried diaper pants, but this caused a lot of irritations ... Does anyone have an idea how I can solve this problem?"* (Chantal, 2010)

## Appendix 5 Caregivers inspection and quality standards

*Caregivers need to follow rules and regulations, to provide their clients with proper care. The government has established an assessment framework that the caregiver must meet, which contains five themes (Cijfers meldingen verpleeghuiszorg en thuiszorg, 2019). The assessment framework consists of several standards and associated assessment criteria. These are based on laws and regulations, and so-called “field standards” that the professional organization of healthcare providers has drawn up. Below the five themes are discussed with their corresponding norms, which are direct quotes from the framework.*

### THEME 1 – CLIENT-ORIENTED

The client experiences that the home care suits his/her needs and contributes to the quality of life.

Norm 1 De cliënt krijgt zorg die aansluit bij zijn actuele zorgbehoeften.

Norm 2 De cliënt krijgt zorg die bijdraagt aan kwaliteit van leven.

Norm 3 De cliënt krijgt de hulp en gelegenheid om zo veel mogelijk zelf de regie te voeren over de zorg thuis, de wijkverpleging sluit daarop aan.

### THEME 2 – INTEGRAL CARE

The client receives customized care home.

Norm 1 De wijkverpleging werkt samen/stemt af met de informele zorgverleners van de cliënt.

Norm 2 De cliënt ontvangt integrale zorg doordat de wijkverpleging als team samenwerkt.

Norm 3 De cliënt ontvangt integrale zorg doordat de wijkverpleging samenwerkt met zorgverleners van andere zorgorganisaties.

### THEME 3 – SAFE HOME CARE

The client gets professional and safe care at home.

Norm 1 De wijkverpleging signaleert risico's in de woonomgeving van de cliënt. Zij bespreekt deze risico 's met de cliënt.

Norm 2 De wijkverpleging is gekwalificeerd en vakbekwaam voor de verpleegtechnische handelingen die ze uitvoert.

Norm 3 De wijkverpleging houdt zich aan de veilige principes in de medicatieketen als zij de zorg voor medicatie (deels) overneemt.

Norm 4 De wijkverpleging let erop dat er een veilige zorgrelatie is tussen de cliënt en zijn formele of informele zorgverleners.

Norm 5 De wijkverpleging past alleen onvrijwillige zorg toe onder de WGBO in noodsituaties en als voldaan wordt aan de noodzakelijke zorgvuldigheidseisen.

### THEME 4 – PROFESSIONAL AUTONOMY OF THE DISTRICT NURSE

The district nurse acts professionally and autonomously.

Norm 1 De wijkverpleegkundige stelt zorgvuldig de (her-)indicatie.

Norm 2 De wijkverpleegkundige functioneert als kwaliteitsbevorderaar.

### THEME 5 – FOCUS ON QUALITY

The organization focuses on care of good quality.

Norm 1 De zorgaanbieder draagt zorg voor het systematisch bewaken, beheersen en verbeteren van de kwaliteit van zorg.

Norm 2 De zorgaanbieder draagt zorg voor borging van kwalitatief en kwantitatief voldoende personeel en benodigdheden.

Norm 3 De zorgaanbieder schept voorwaarden voor een cultuur gericht op leren en verbeteren.



## Appendix 6 Ideation - Morphologic chart

To create a large variety of ideas the morphologic chart technique was used. First, the product was divided into four main functions: shape and placement, capturing urine, storing urine, and disposal of the urine. For each function ideas were generated onto post-its, as can be seen in the image below:



Ideas were created by combining different functions. These different ideas were later in the process categorized into one of the three design directions. On pages 89-91 scans can be found of this part of the ideation process.

These ideas are categorized into one of the three design directions. This gets a clear idea of what type of solutions would belong to which design direction, three collages were made. To be able to determine what this most suitable direction is these three collages were used to discuss the different directions with the client, the experts, and coaches. On pages 92 to 94 the three collages can be found. For a clear description of each design direction and the chosen direction, go to chapter 2: ideation.

velcro

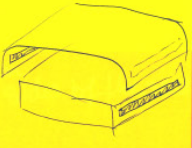

full cover elastic full cover foldable

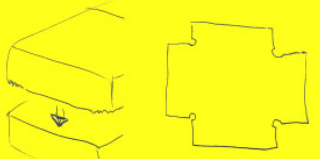

SEAT  
BLADES FROM CHAIR TO ARMREST  
ALSO COVERS THE SIDES  
NO FLOW UNDER  
PIPES PUMP INTO BAG



Partly disp capillary different distrib of foam  
hydrophobic  
Flow to the lowest point  
pinag

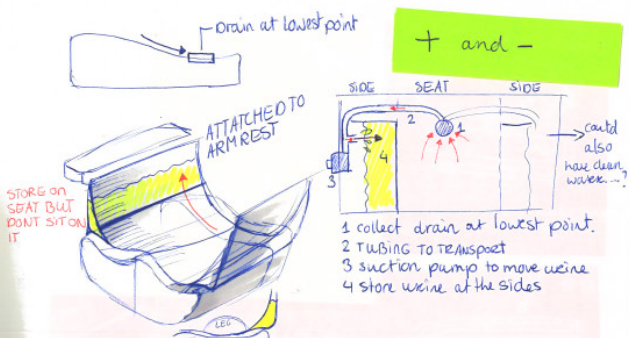
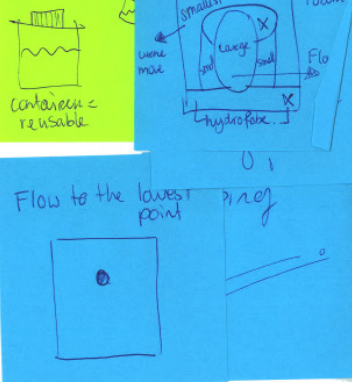

### MOVE URINE TO THE SIDES

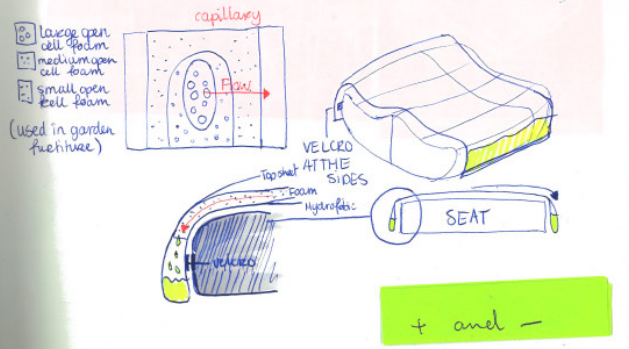

under seat



elastics around band around the seat  
only under legs



Flush with water  
clean water from the front

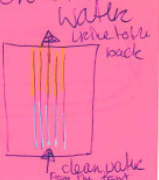

lock



fabric FLUSH WITH water  
1 day  
< 2L

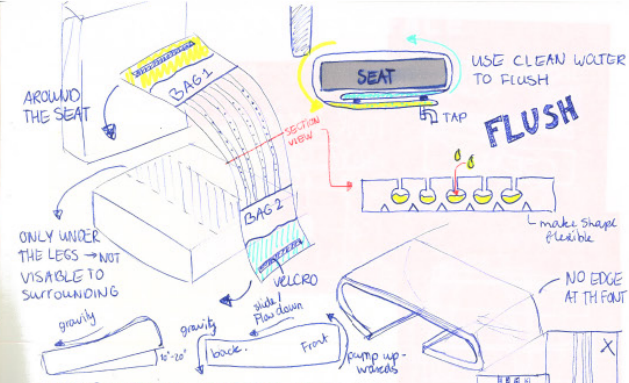
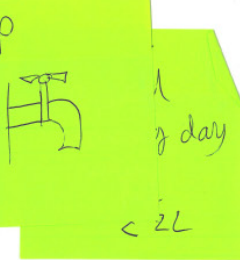
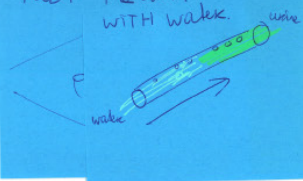

### AROUND THE SEAT

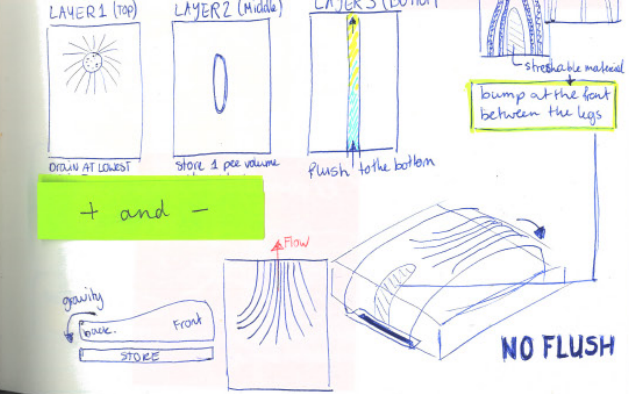

on seat surface

SEAT

move urine FROM MIDDLE 2

back OR sides

seat

Zijkanten

expanding sides.

loose on the

ANTI SLIP

product

ANTI SLIP

SEAT

capillary Lizard

Flow unidirectional OR

to the lowest point OR to the side

expanding shape create more volume

### ON THE SEAT SURFACE

body contact sensitive

storing

ORGANIC SHAPE OF THE SEAT

High P. Low

FRONT BACK

LAYER 1 collect

LAYER 2 pattern Lizard

LAYER 3 store

pattern Lizard

unidirectional flow (against gravity) DOES NOT flow BACK

LEG EMPTY

LEG

urine stored expanding sides.

PREMOULDED

topsheet plastic

FOAM MATERIAL THAT DOES NOT EXPEND

water wicks and moves grey point upwards (decreasing volume)

FOAM ERGONOMIC SHAPE AS THE WHEELCHAIR

Flow

hole in the Drawers

DRAIN

can be, by us

dig

F Douch putje

between legs.

changes made to the seat

TOP SHEET

slide

pellets compostables

GFT afval

campoot soil.

Groeven

previous tested concept hole was pain full → could be solved by filling the the hole = no feeling Of there being a hole.

honey combs, to give strength Sagging.

TOP SHEET (silicone)

product fills up the Hole → Feels like a flat surface.

STORAGE

HOLE AT THE LOWEST POINT (prototype 1+2) (problem pain Full)

WITH SIPHON DRAIN (Aquaponics)

deains AT CERTAIN HEIGHT → deain full & volume.

plekchen mesh (trunkal)

je borgt extra "ruggen" geen nat gevoel

instead of topsheet

Frame met opspansen gaas

TOPSHEET product.

SEAT

storage

A SLIT INSTEAD OF A HOLE → BETWEEN THE LEGS → LESS NOTICEABLE THAN A HOLE

CHANNELS TO MOVE URINE TO THE SLIT

↳ USER: voelt het heel zacht en line more comfortable

close to the body

attached to underwear

inside underwear

hole in the seat

washable / reusable

Fully disposable

washable female to the front

washable down

catheter bag

half underwear

→ no irritation at the legs

→ catch urine closer to the source

shape flexible

NO EDGE AT THE FRONT

**WEARABLE**

HOLE IN THE SEAT

product placed inside hole

like female urinal

problemen kankelen op van de zitken eet. kan invloed hebben op het aan sluiten van het product.

> Wearable is an extra step for care givers.

> last step, → user needs to lay down for a wearable → harder to change.

hard preformed shell

TOP SHEET

SHAPE

ABSORPTION

**FLAT DIAPER**

Frame

pre formed open structure

diaper material

NO HOLE NEEDED BUT A

SEALING SEAT

3D FABRIC

absorbent

bird absorbent

in line bed

Fiema Based medical cathodic material

zoek nieuw fabricant in NL

DOOR SINGE

voorzijde

achterzijde

hoofse vestel?

hoofse vestel?

# STORE URINE OUTSIDE OF THE SEAT SURFACE

1

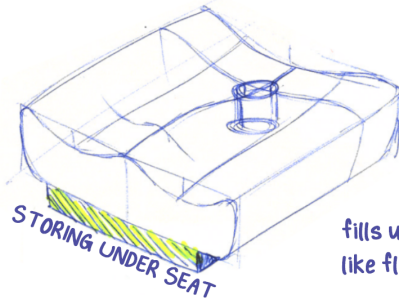

Honeycomb to prevent sagging



fills up hole to feel like flat surface

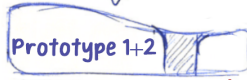

Problem: hole is painful



drains all at certain height

top sheet silicone

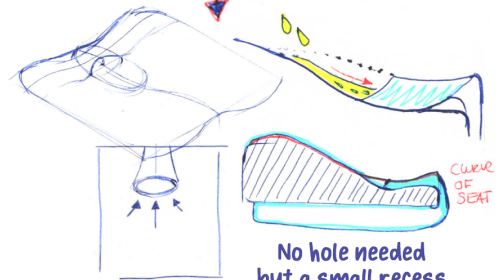

No hole needed but a small recess

crease of seat

2

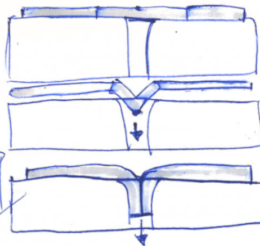
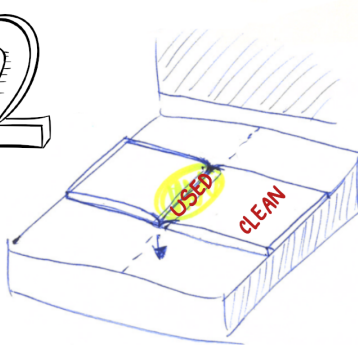

flat diaper material

pull used material down

new dry material on seat used material under seat

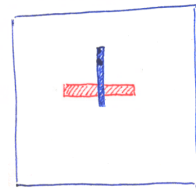

Slit instead of a hole less noticable

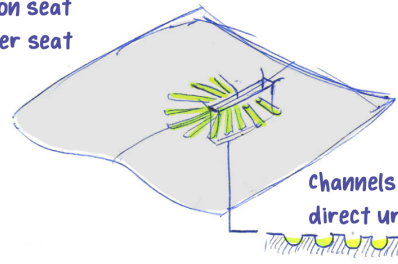

Channels to direct urine

3

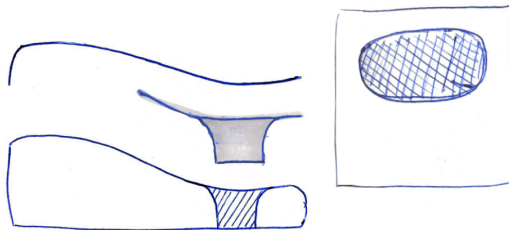

curved frame in shape of seat

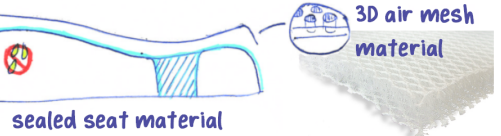
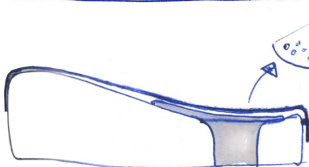

3D air mesh material

sealed seat material

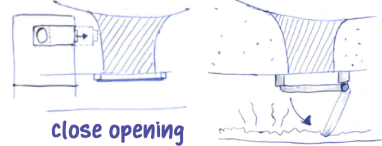

close opening

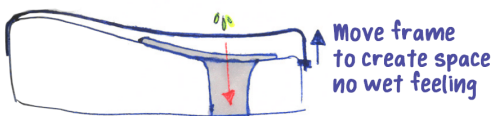

Move frame to create space no wet feeling

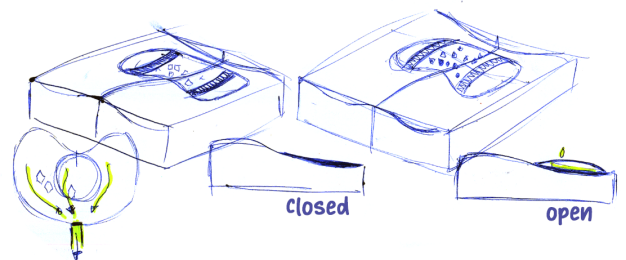

closed

open

# COLLECT AND STORE URINE ON THE SEAT SURFACE

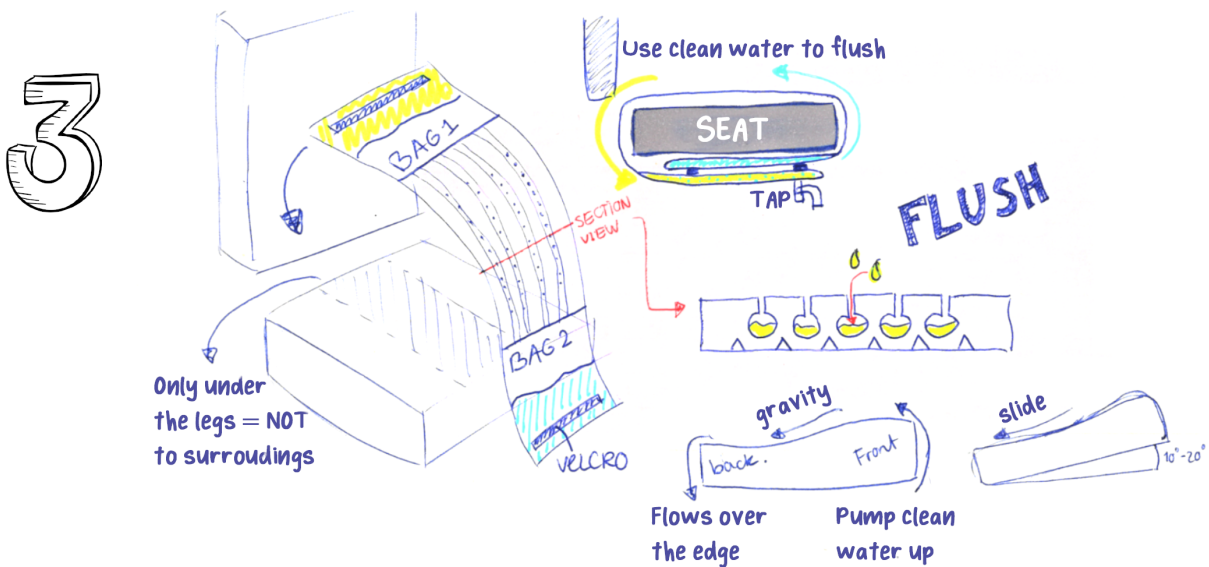
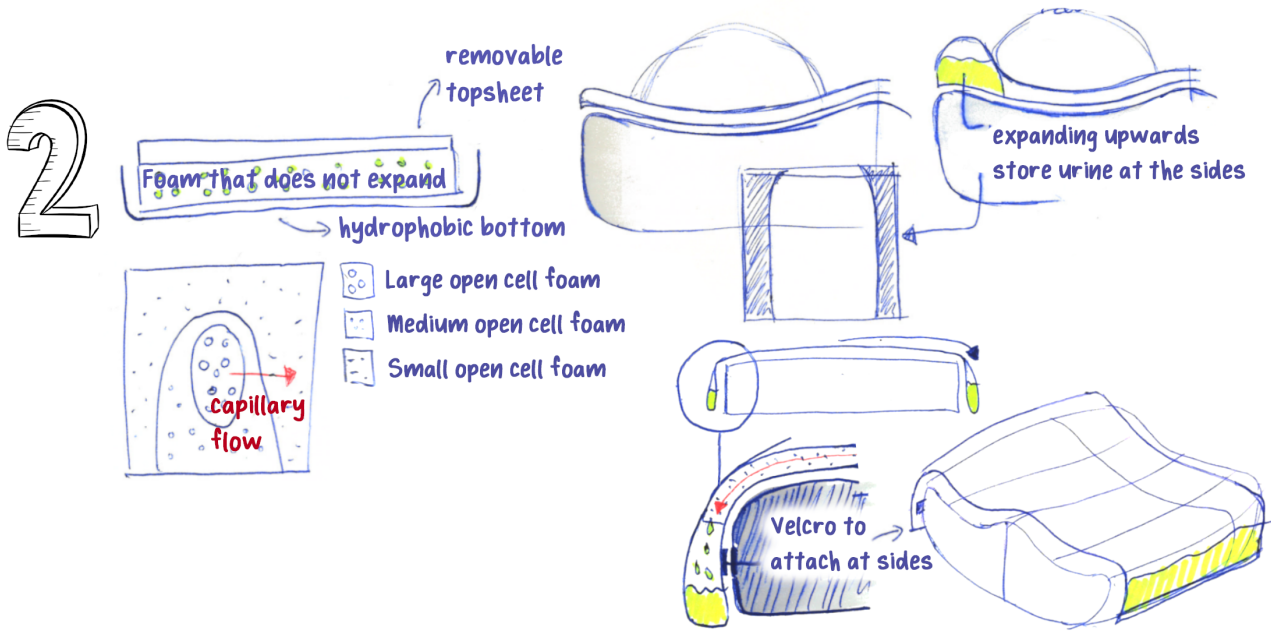
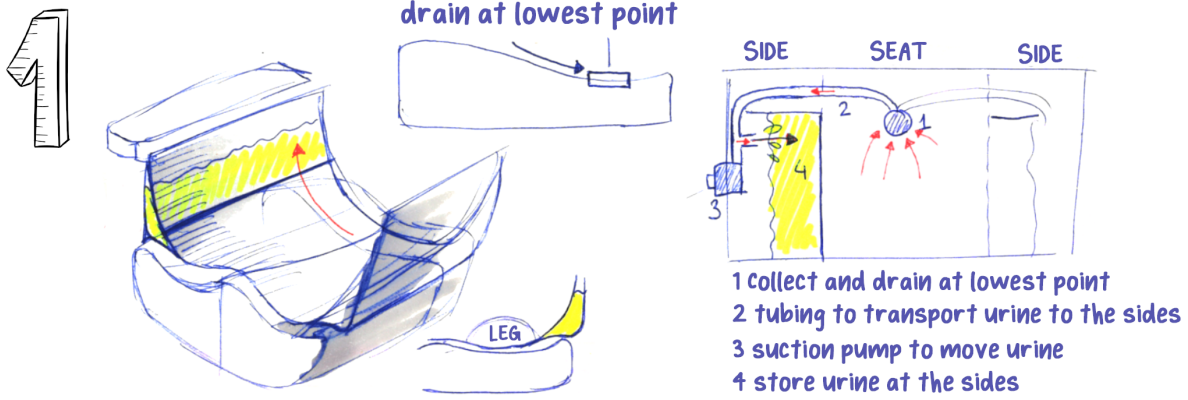

# WEARABLE TO COLLECT THE URINE AND COLLECT OUTSIDE OF THE SEAT SURFACE

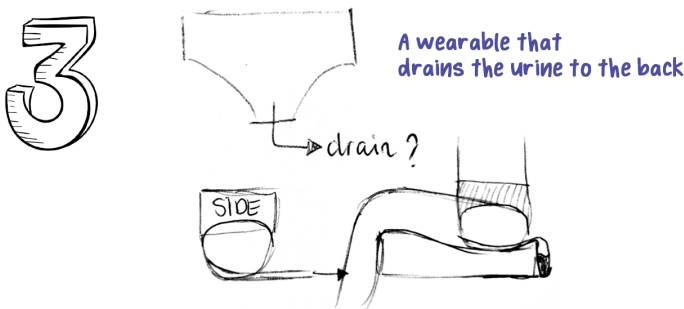
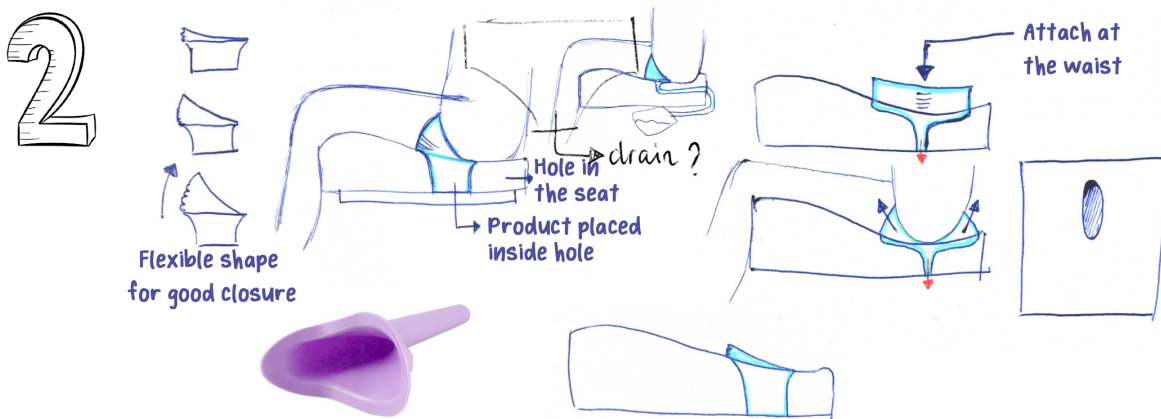
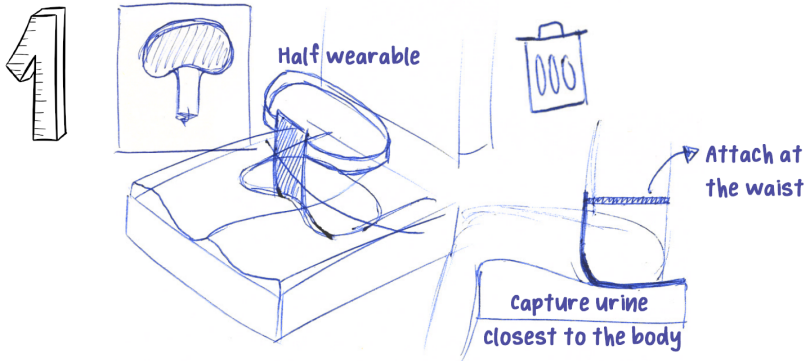

To get a better idea of the feasibility of the concepts some material tests were conducted to find the effect of a (simulated) urine stream on different types of materials. The materials tested were open-cell foam and multiple types of fabrics. To recreate the urine flow, 30 ml of colored water was poured onto the material as fast as possible, creating a stream of approximately 30 ml/s (see chapter 1: female urination). To make the flow of the water more visible blue food coloring was added to the water.

**OPEN CELL FOAM**

*Method*

Three types of open-cell foam were tested in different thicknesses. To measure the amount of urine that could stay behind inside the foam, the amount of liquid before and after pouring it through the material is measured. Food coloring is added to the water to visualize the spread of the liquid.

The test setup can be seen in Figure 70. The foam is placed onto the measuring cup and with a syringe, the colored water is sprayed through the material. Afterward, the amount of liquid left is measured using a scale (because the difference is too little to read from the measuring cup). The material needed for this test are:

- » open cell foam
- » syringe
- » food coloring
- » measuring cup
- » camera
- » scale

*Results*

The test results can be found in Table 9 and Figure 71.

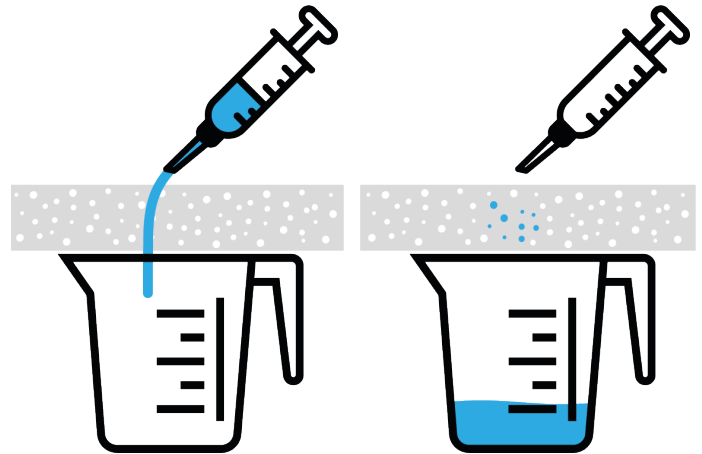
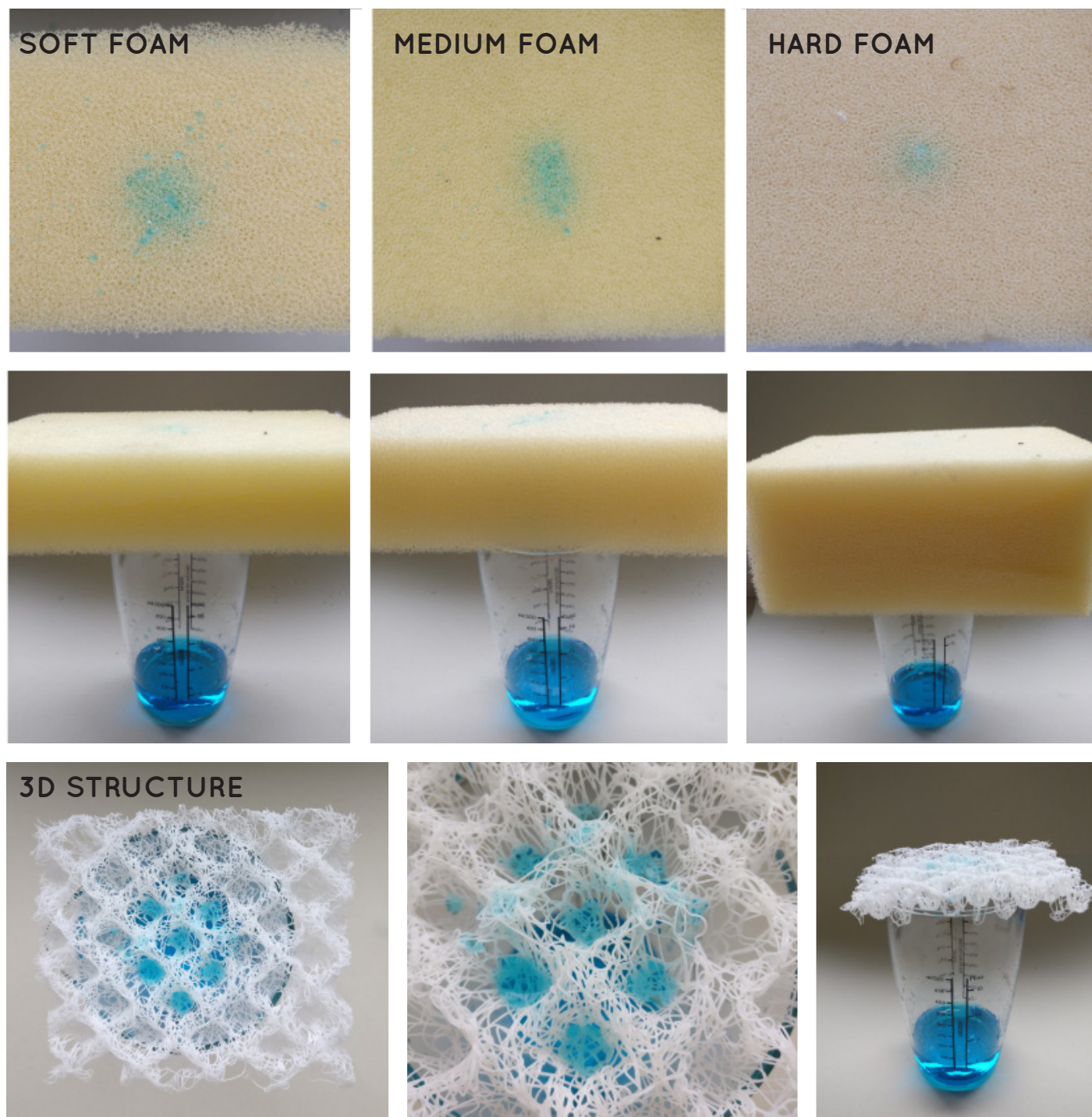

Figure 70 Test set-up.

#	material	thickness [mm]	liquid before [ml]	liquid after [ml]	What happened: observations
1	Soft open cell foam	50	100	95	Part of the liquid stayed locked into the foam. It did not spread very far to the sides.
2	Medium open cell foam	60	100	92	Part of the liquid stayed locked into the foam. It did not spread very far to the sides.
3	Hard open cell foam	100	100	90	Part of the liquid stayed locked into the foam. It did not spread very far to the sides.
4	3D structure	15	100	95	Water lingers in the dimples of the 3D material.

Table 9 results foam test.





**Figure 71** Test result photos.

**Conclusion**

The largest amount of the liquid will flow through the foam and it does not absorb the liquid as you would expect from a regular foam. However, because the open cells are still quite small, droplets of the liquid get remain inside the foam. The liquid does not spread through the material but just remain still. The three types of foam had a different thickness. The results suggest that the thicker the foam the more liquid will remain inside, possibly because the liquid has to travel a longer distance through the material.

If the water is exchanged for urine, remaining urine in the foam is not desirable in terms of smell and hygiene. The same happened with the 3D structure material. This shape had a wave structure. Inside the dimples, small layers of water remained (like small pools). The main problem of open-cell foams and structures is that it locks liquid into the material, while you want it to flow through.

## Appendix 7 Material testing

### FABRIC TOPLAYER

#### Method

Seven different types of fabrics were tested, which included topsheet, spacer fabric, and mesh fabric. To measure the amount of urine that could be absorbed by the fabric, the amount of liquid before and after pouring it through the material is measured. Food coloring is added to the water to visualize the spread of the liquid. The test setup can be seen in Figure 72. The fabric is placed onto the measuring cup and with a syringe, the colored water is sprayed through the material. Afterward, the amount of liquid left is measured using a scale (because the difference is too little to read from the cup).

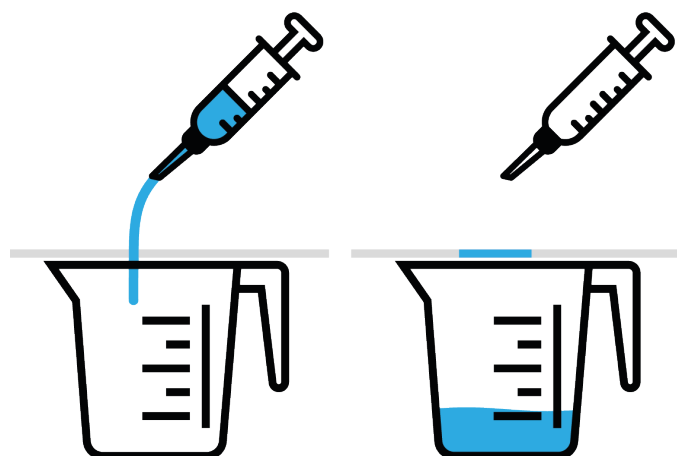

Figure 72 Test set-up.

The material needed for this test are:

- » different fabric materials
- » syringe
- » food coloring
- » measuring cup
- » camera
- » scale

#### Results

The test results can be found in Table 10 and Figure 74.

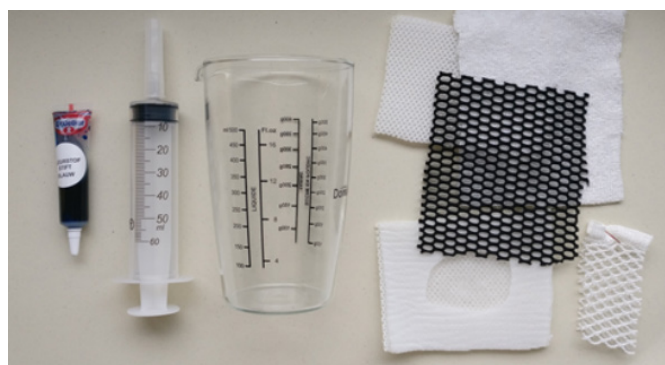
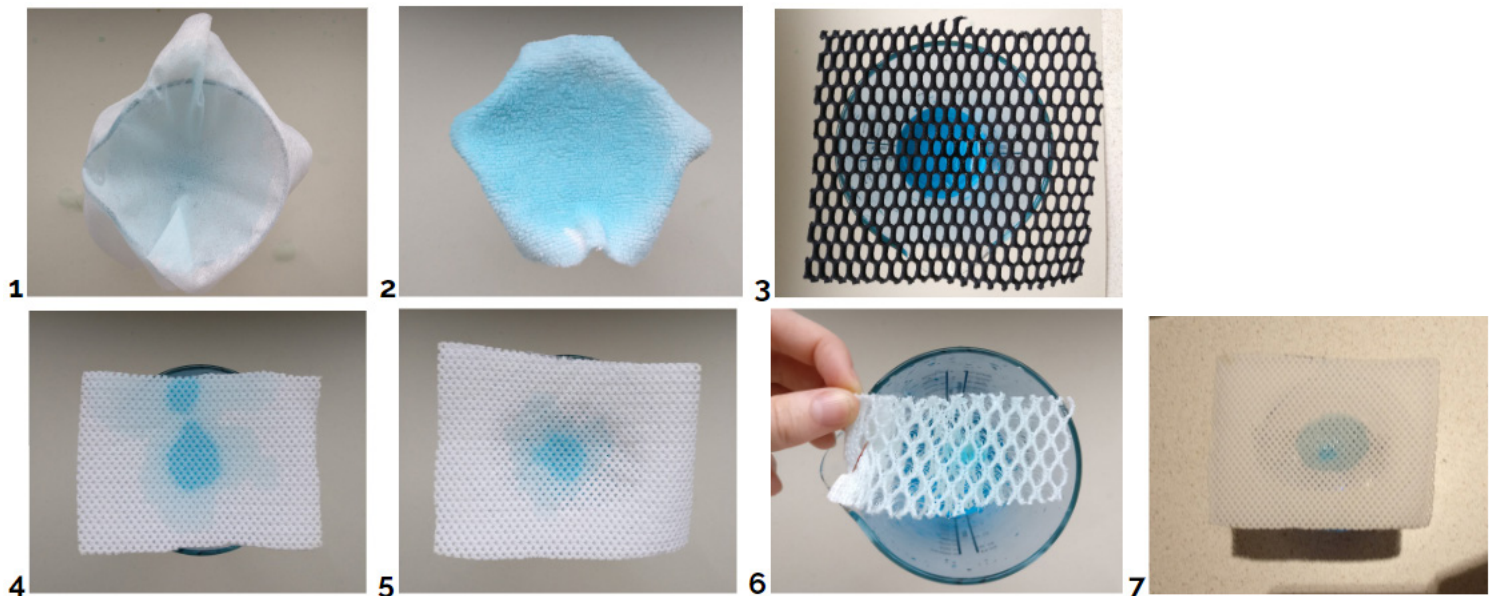

Figure 73 Test materials.

#	material	thick ness [mm]	liquid before [ml]	liquid after [ml]	wetness after 5 min	wetness after 10 min	What happened: observations
1	top layer diaper	<1	100	95	wet	wet	Soaked up the liquid and after a minute the full patch was soaked.
2	Toplayer of reusable diaper	1.5	100	90	wet	wet	Soaked up the liquid and after a minute the full patch was soaked.
3	Mesh fabric	1.5	100	99	only wet at the area of application surrounding fabric dry	only wet at the area of application surrounding fabric dry	The mesh fabric did let almost all liquid through, except for what stayed inside the openings (see picture). Material did not feel wet or damp. However it is not comfortable to sit on for long period.
4	3D spacer fabric	5	100	97	damp	damp	The 3d layers would hold the liquid in so a part was captured between the top and bottom layer. The captured liquid would be absorbed by the top and bottom layer, resulting in a wet feeling over the full surface.
5	3D spacer fabric + opening	5	100	99	damp	slightly damp	The 3d layers would no longer hold the liquid so there was less moisture spread. After 10 min the material did feel a bit damp still. With cutting the bottom part out it did loose a little of its firmness in that area.

6	3D spacer fabric + waterproof	5	100	99	only wet at area of application surrounding fabric dry	only wet at area of application surrounding fabric dry	The 3d layer did not hold the liquid nor did to spread the liquid over the surface. However because of the waterproof treatment there would still be a small wet feeling area. The advantage over no treatment is that it can not spread.
7	Thick 3D spacer fabric	7	100	98	wet	wet	This type of spacer fabric is thicker and has a more open cell structure but is also stiffer and rougher. The liquid flowed through quickly, but the thickness did keep liquid locked in the middle. From the middle the liquid was absorbed by the fabric. Giving it a wet feeling. The thicker the material the more likely it is for the urine to slow down and get locked- in by the fabric.

**Table 10** results foam test.



**Figure 74** Test result photos.

**Conclusion**

The fabrics can be divided into two groups, normal fabrics, and spacer fabrics. The normal fabrics will function best with an absorbent material directly underneath it (like with the diaper). But in this set-up, these materials don't reach their full potential. They absorb the liquid, making them unsuitable. 5 ml might seem low but during the day this will become very unpleasant. The spacer fabric absorbed less liquid. The configuration with the bottom layer removed has better flow through than without the layer removed. That leaves two options: treated or

untreated fabric. The waterproof treatment will help to leave the surrounding material dry, but the area of application wetter. The choice between these two options should be made based on user experience.

## Appendix 8

## The lewis Orthosis

The concept is developed to fit the lewis seat orthosis. Therefore, during the embodiment this seat is used in decision making. In this paragraph the seat specifics will be given.



**55-60 cm depth**  
**50 cm width**



**LAYER 1 | HARD BOTTOM ERGONOMIC**  
This layers is a combination of a wooden plank and weaved straps (see the bottom image), which is topped with the ergonomic shaped hard foam seat.

*SIZE* - 50-56 cm depth 46 cm width

*CHANGES TO BE MADE:* A small gap needs to be made at the back of the seat to let the pipe through to the back of the seat.



**LAYER 2 | SOFT TOPDECK COMFORT**  
The second layers lays loose on top of the first layer. This soft foam provide comfort for the user.

*SIZE* - 58-62 cm depth 48 cm width

*THICKNESS* - 4-5 cm (4 is most used)

*DENSITY* - 60 kg/m<sup>3</sup> 4,5 KPA

*CHANGES TO BE MADE:* The hole will be made to fit the product into this layer. This will retain the ergonomic shape and structure of the first layer and secure the product to prevent moving.



**LAYER 3 | FABRIC COVER**

To hold the two layer together a fabric cover is put over the seat. This stretchable fabric is connected to the wooden bottom of the seat with velcro. This will make it easy to remove and wash.

*CHANGES TO BE MADE:* To fit the product a hole will also need to be made in the fabric cover



MECHANICAL RUBBER

**Durometer\* Conversion Chart**

Approximate Hardness Value  
(to be used as a guide)

Type	Extra Soft / Soft (Chewing Gum)				Medium Soft (Pencil Eraser)			Medium Hard (Windshield Wiper Blade)						Hard (Skate Wheel)			Extra Hard (Bowling Ball)		
<b>Shore A</b> Rubber, Soft Plastic & Polyurethane	10	15	20	25	30	35	40	45	50	55	60	65	70	75	80	85	90	95	100
<b>Shore B**</b> Rigid Rubber			6	12	17	22	27	32	37	42	47	51	56	62	66	71	76	81	85
<b>Shore C**</b> Rubber & Plastic					9	12	14	17	20	24	28	32	37	42	47	52	59	70	77
<b>Shore D</b> Hard Rubber & Plastic					6	7	8	10	12	14	16	19	22	25	29	33	39	46	58
<b>Shore O**</b> Soft Rubber	8	14	21	28	35	42	48	53	57	61	65	69	72	75	79	84			

Type	Soft (Slice of Bread)				Med. Soft (Seat Cushion)			Med. Firm (Mouse Pad)						Firm (Tennis Ball)		
<b>Shore OO</b> Sponge	45	55	62	70	76	80	83	86	88	90	91	93	94	95	97	98

Type	Very Soft (Slice of Bread)		Extra Soft (Pillow)		Soft (Mattress)		Firm (Tennis Ball)		Extra Firm (Styrofoam Cup)		Very Firm (Life Preserver)	
<b>Density</b> Foam	0 - 2 PSI 0 - 14 kPa		2 - 5 PSI 14 - 34 kPa		5 - 9 PSI 34 - 62 kPa		9 - 13 PSI 62 - 89 kPa		13 - 16.5 PSI 89 - 114 kPa		16.5+ PSI 114+ kPa	

\*Durometer is the standard for hardness measurement of rubber, plastic, sponge & non-metallic material.

\*\* Not commonly used

[www.mechanicalrubber.com](http://www.mechanicalrubber.com)

Table 11 Durometer Conversion Chart (Durometer Conversion Chart, n.d.).

## Appendix 10 Silicone flexibility and softness test

To find out how silicone will feel and function in different shapes and thicknesses a material test was conducted. The goal of this test was to find out the compression and flexibility of the silicone. 10 test cubes were printed on an Ultimaker 2+. The cubes had a height and depth of 4 cm and a width of 6 cm, which were based upon the assumed size of the product (cross-section). A shore 20 silicone was poured into the cubes.

### Test cubes

- » 1 blanco test cube
- » 1 cube with brim
- » 2 cubes with a hole
- » 2 cubes with a grid
- » 2 cubes with a honeycomb pattern
- » 2 cubes with lines

### Compression

To test the silicone a cube was made without any additions. Even though a low shore silicone was used, the compression of the cube did not come close to that of foam. The expected problem, which is described in Figure 76 will likely happen.

There were also two test cubes printed with a small and large hole. A thick-walled product would still need an opening to drain the urine. The small circular hole had little deformation under pressure (when the hole was placed at the bottom). Flipping the cube around, caused more deformation. The large oval opening had more deformation. Under (very high) pressure the opening could be pressed closed. This could block the urine drainage. Flipping the opening upwards, cause a lot of deformation with very low pressure. There was not enough wall thickness. The wall thickness surrounding the drainage opening should be high enough to not block the opening. This can be seen in the photo's in Figure 77.



Figure 75 Test cubes.

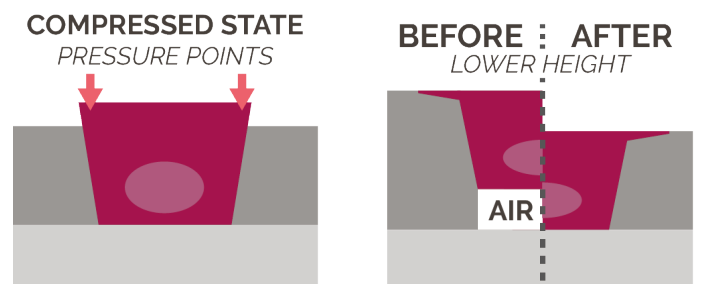
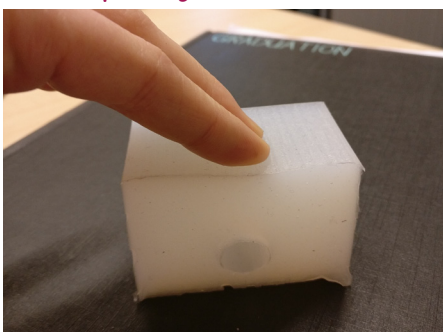
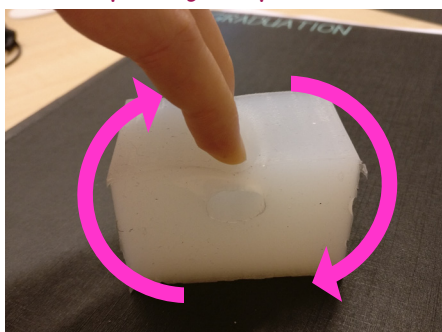

Figure 76 Problem with compression.

Small opening - Bottom



Small opening - Top



Large opening - Bottom

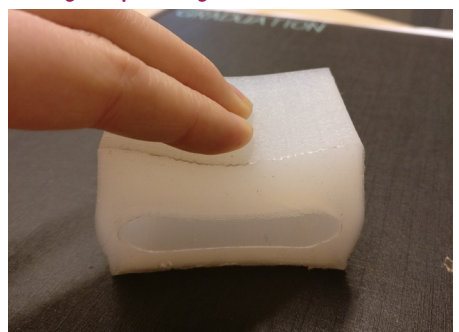

Large opening - high pressure



Large opening - Top



Figure 77 Compression results.

### Flexibility

Three patterns were tested. For each pattern, a shallow and a deep pattern was created. A pattern could be useful for letting the product follow the curve of the hard bottom (which is double curved). The honeycomb pattern was the most flexible, especially when bent in two directions. The grip was also flexible, but less than the honeycomb. The line pattern was the least effective. The result of the difference in the dept of the pattern was the same for all three: deeper = more flexible. Figure 78 shows the result of the different test cubes, where the right side of the cube is bent upwards.

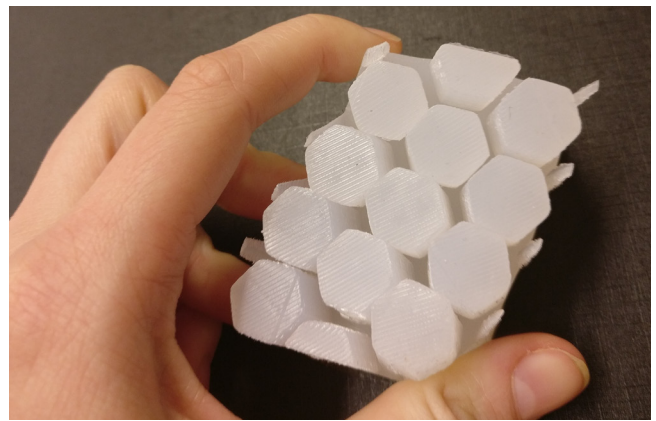

Shallow lines

Deep lines

Deep grid

Deep Honeycomb

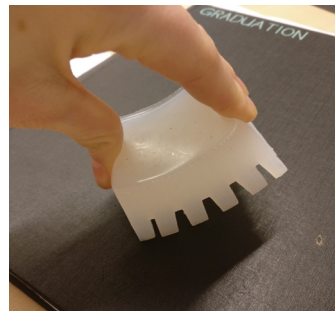
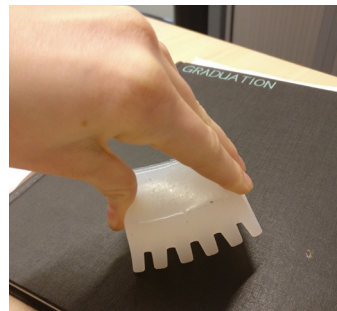
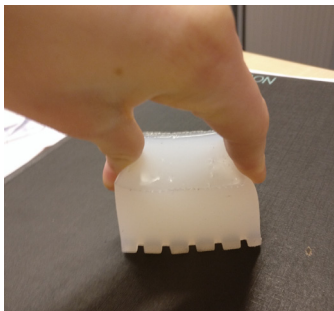

Figure 78 Flexibility test.

### Brim

Adding a brim at the edge is an idea to help protect the seat around the product and smooth over the edge between the product and the seat. This test cube shows that it bends easily, both up and downwards (see Figure 79). Adding a brim could be this could be beneficial for the comfort of the product.

Bending down

Bending up



Figure 79 Brim test.

### Conclusion

The different small silicone test provides valuable information that can be used into the design. This can be found in chapter 3.1.1.

## Appendix 11 Scanning methods

*In the case of a custom product, the curve has to be mapped for each individual. This requires a step to find this curve. Different possibilities to do so are explored to see which one is best, they can be found in Table 12.*

TYPE	DESCRIPTION	DOWNSIDES	SUITABLE
<b>3D scanning</b>	Using a 3D scanning method to get a digital model of the user's anatomy. The scan needs to be made from the bottom side, therefore the person should sit on an acrylic plate.	The acrylic plate is not representative for the body fat distribution when sitting on the (foam) orthosis. (Naagen, B., personal contact, 2020)	NO
<b>Foam imprint</b>	This technique is used for making foot imprint for foot orthosis. A person can sit on the foam which will compress under pressure to create an imprint.	The foam is more similar to the situation of the seat, in comparison to sitting on the acrylic plate. It could be suitable for the target group with the help of a caregiver. However, the foam will not capture the whole shape, when to foot blocks are used. Larger and thicker foam would be required.	YES
<b>Air mat</b>	A rescue mat is filled with air and the user will get in a comfortable position on the mat. Once comfortable, the air is sucked out of the mat, leaving the shape of the person (Smulders, et. al. , 2016).	According to the client air mats or pillows are difficult for the target group to sit on, it can cause an unrepresentative posture. It also requires a lot of post-processing and is therefore too inaccurate (Naagen, B., personal contact, 2020).	NO
<b>Plaster cast</b>	Plaster casting is normally used to make a copy of a shape (e.g. face, baby feet, or pregnant belly). Plaster is applied to create a negative, which can be used as a mold. The mold can be used to replicate the form. However, the negative form is sufficient for the purpose.	Working with plaster is too messy an unpractical for the area it needs to be applied to. This will not be pleasant for the user.	NO

**Table 12** Scanning methods for making a custom product.



## Appendix 12 Urinal devices duration test

The urinal devices are designed to enable females the urinate standing up. Meaning they are designed for a standing position. The product will be used in a sitting position. Therefore, the shape of the fud's might not match the sitting position. To test the comfort of the FUD in a sitting position a duration test was conducted. A longer duration will give a more realistic result to the reality because the user will sit on the product the whole day.

### Method

To make it possible to do this test, three FUD's were cut in two. This would enable to put it on the seat. After placed the FUD on the seat and sitting down a timer is set for 2 hours. The participant (me) is not to leave the chair for two hours. Because the target group will not have the ability to move around this should be done as well. The test the comfort during static sitting. After the first hour, a rating form is filled in, which will rate the comfort (from 1-5) for the 3 areas of the product. This is done again after the second hour.

The material needed for this test are:

- » Three FUD's
- » Scissors
- » Chair
- » Timer
- » Rating form
- » Pen
- » Cover material (mesh)
- » Tape

### Results

The first FUD was made from hard silicone. This material was uncomfortable. At the end of the two hours, it began to become slightly painful. Area 3 was to most uncomfortable. Area 1 and 2 weren't uncomfortable but were noticeable. Adding a fabric cover material slowed down the discomfort, but it would still appear. The fabric did smooth out the edges at area 3 a little and reduced the feeling of sitting against an opening.

The second and third FUD were both made from soft silicone, which was more comfortable. After two hours there was no discomfort. The material did become a little sweaty which was unpleasant. These two FUD's were slightly different in shape, but this did not affect the comfort. For all three FUD's, the curve felt on the small side in the sitting position. (The rating form for each test can be found on the next page)

### Conclusion

Soft silicone is more suitable for static sitting and lowers the chance of discomfort and pressure injuries. There was no discomfort experienced after 2 hours. All three shapes were experienced as small. To ensure a good closure the curve in area 1 should be higher for good closure. Adding a toplayer will improve comfort. It will prevent a sweaty feeling, mask the opening, and smooth out the edges.

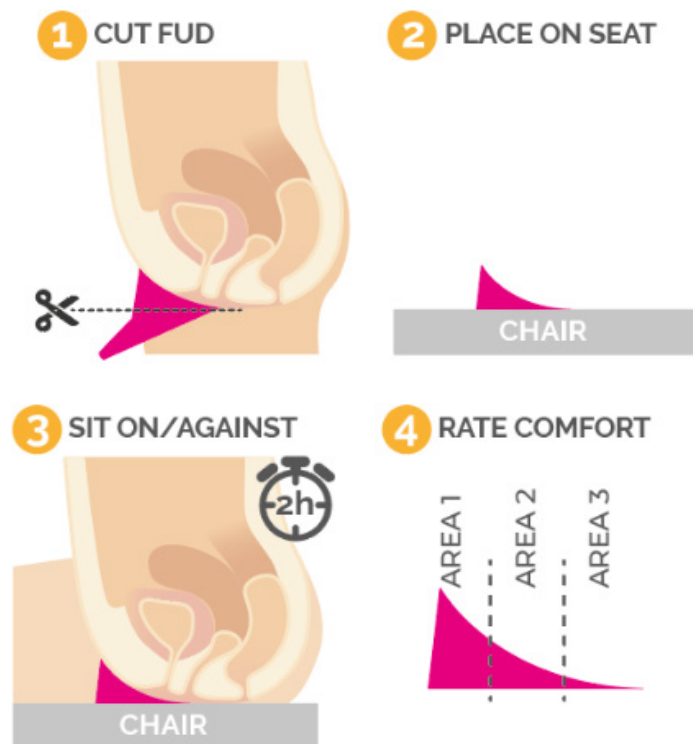
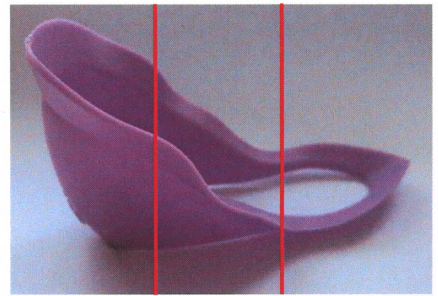

Figure 80 Test set-up

## Comfort Test using the pain assessment tool 1

No pain	mild	moderate	Bad	severe pain
1	2	3	4	5

**No pain** = feel it, but not unpleasant  
**Mild pain** = can be ignored  
**Moderate** = interferes with tasks  
**bad pain** = interferes with concentration  
**severe pain** = interferes with basic needs



1st hour

AREA 1

No pain		painful		
1	2	3	4	5
X				

AREA 2

No pain		painful		
1	2	3	4	5
X				

AREA 3

No pain		painful		
1	2	3	4	5
		X		

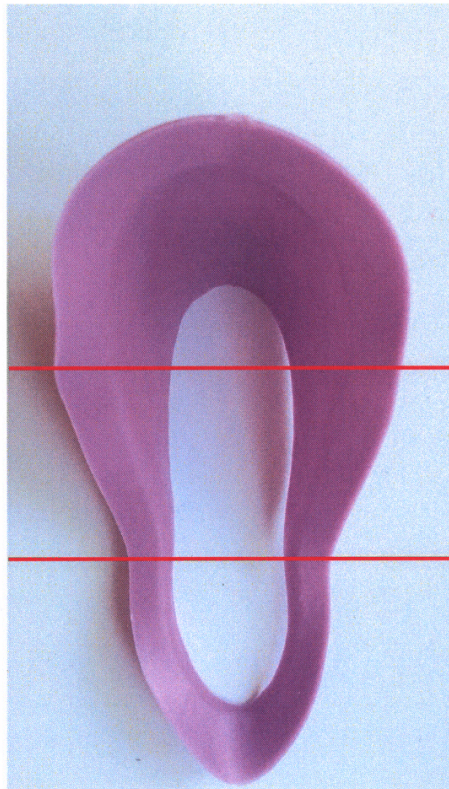

2nd hour

AREA 1

No pain		painful		
1	2	3	4	5
X				

AREA 2

No pain		painful		
1	2	3	4	5
X				

AREA 3

No pain		painful		
1	2	3	4	5
			X	

Remarks about shape:

The back of the shape (where you sit on) curves a little bit upwards.  
 In combination with the hard silicone this is uncomfortable (pretty fast)  
 the full shape felt a bit small.

Were actions performed to increase comfort during test and what:

After the first hour I started to move around (Feedback loop)  
 Was happy to leave afterwards. Was hard to concentrate on what I was doing  
 The front (AREA 1) was noticeable but not uncomfortable.

## Comfort Test using the pain assessment tool 2

No pain	mild	moderate	Bad	severe pain
1	2	3	4	5

No pain = feel it, but not unpleasant  
 Mild pain = can be ignored  
 Moderate = interferes with tasks  
 bad pain = interferes with concentration  
 severe pain = interferes with basic needs

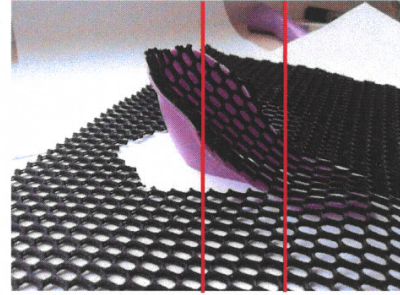

1st hour

AREA 1

No pain					painful	
1	2	3	4	5		
X						

AREA 2

No pain					painful	
1	2	3	4	5		
X						

AREA 3

No pain					painful	
1	2	3	4	5		
	X					

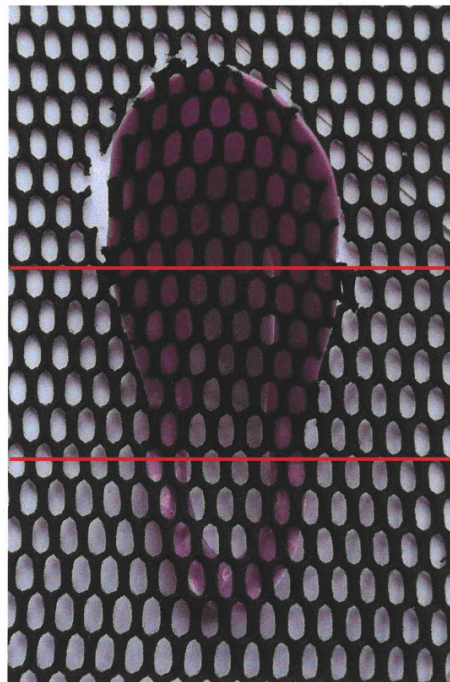

2nd hour

AREA 1

No pain					painful	
1	2	3	4	5		
X						

AREA 2

No pain					painful	
1	2	3	4	5		
X						

AREA 3

No pain					painful	
1	2	3	4	5		
			X			

Remarks about shape:

Because of the ~~em~~ top layer it took longer to get un comfortable covering the opening was pleasant but attaching it with tape is not strong enough.

Were actions performed to increase comfort during test and what:

less actions at the beginning where needed to get/stay comfortable. But the mesh fabric became noticeable at the 2nd hour. material too rough

### Comfort Test using the pain assessment tool 3

No pain	mild	moderate	Bad	severe pain
1	2	3	4	5

No pain = feel it, but not unpleasant  
 Mild pain = can be ignored  
 Moderate = interferes with tasks  
 bad pain = interferes with concentration  
 severe pain = interferes with basic needs

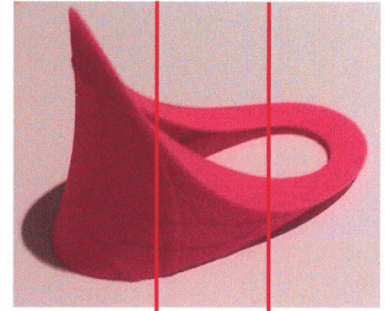

1st hour

AREA 1

No pain					painful	
1	2	3	4	5		
8						

AREA 2

No pain					painful	
1	2	3	4	5		
8						

AREA 3

No pain					painful	
1	2	3	4	5		
8						

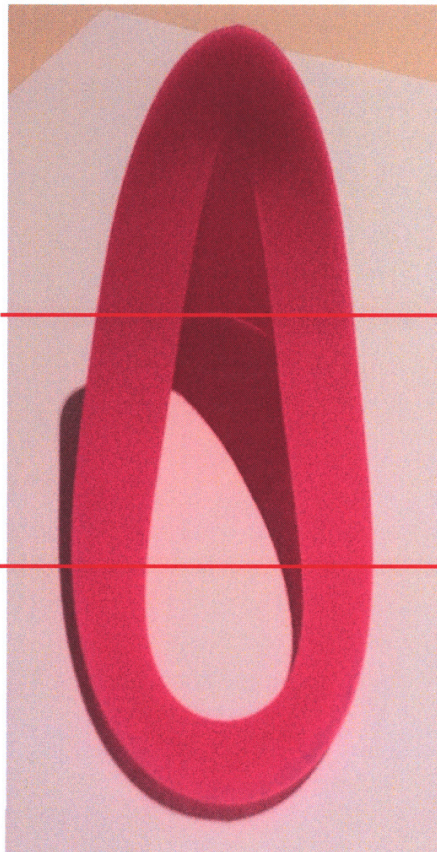

2nd hour

AREA 1

No pain					painful	
1	2	3	4	5		
8						

AREA 2

No pain					painful	
1	2	3	4	5		
8						

AREA 3

No pain					painful	
1	2	3	4	5		
8						

Remarks about shape:

lock upside down compared to tool 4. Was comfortable to sit on (All areas). No discomfort after two hours. height of Area 1 low

Were actions performed to increase comfort during test and what:

No, not more than regular sitting on a chair.

\* silicone became a little sweaty after 2h, a cover would help with this as well

## Comfort Test using the pain assessment tool 4

No pain	mild	moderate	Bad	severe pain
1	2	3	4	5

**No pain** = feel it, but not unpleasant  
**Mild pain** = can be ignored  
**Moderate** = interferes with tasks  
**bad pain** = interferes with concentration  
**severe pain** = interferes with basic needs

1st hour

AREA 1

No pain					painful	
1	2	3	4	5		
X						

AREA 2

No pain					painful	
1	2	3	4	5		
X						

AREA 3

No pain					painful	
1	2	3	4	5		
X						

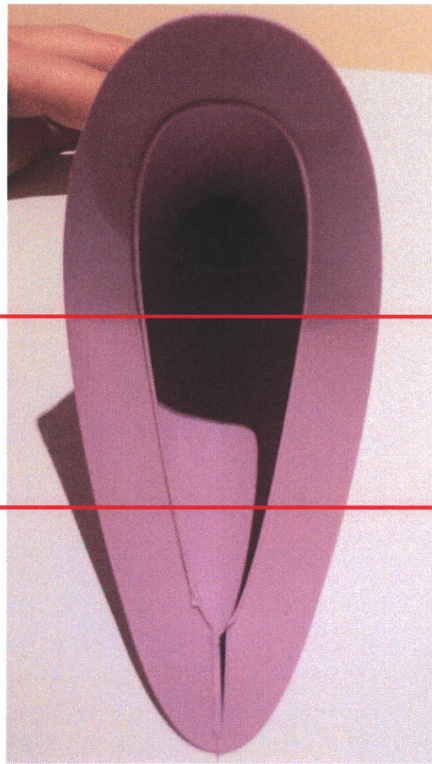

2nd hour

AREA 1

No pain					painful	
1	2	3	4	5		
X						

AREA 2

No pain					painful	
1	2	3	4	5		
X						

AREA 3

No pain					painful	
1	2	3	4	5		
X						

Remarks about shape:

comfortable but the height of Area = low  
(same as tool 3)

Were actions performed to increase comfort during test and what:

same as tool 3.

## Appendix 13 Drainage test

The product should have a small buffer that can temporarily hold the urine before drainage. The drainage should be fast enough that the buffer will not overflow. The drainage test will look into the diameter of the tube that is needed when there is a buffer of +/- 30 ml. It will also look at the influence of height on the drainage speed.

### Method

A product was printed on a Ultimaker 2+, as well as the tubing connectors. During the test, the product will be placed under a 20 degrees angle. 300 ml water is poured through with a speed of (around) 36 ml/sec. This speed is created by drilling a small hole into the cap of a bottle. Each test

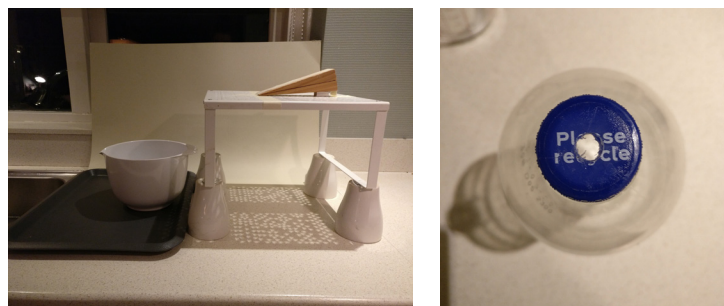

The material needed for this test are:

- » A 3d printed product with buffer inside
- » 3 diameter of tube, 6,7,8 mm
- » 3 tube connectors
- » bottle, with a opening that simulates the max. urine stream.
- » Elevation elements
- » Timer
- » bowl
- » measuring cup
- » pen and paper.



Figure 81 Test set-up

### Results

The results are shown in Table 13.

		Inside diameter [mm]						
		8		7		6		
Height [cm]		time empty [sec]	buffer needed	time empty [sec]	buffer needed	time empty [sec]	overflow after [sec]	buffer needed
5	#1	12,63	No	15,91	No	x	3,00	to small
	#2	12,90	No	16,16	Yes	x	x	x
	#3	12,96	No	17,16	Yes	x	x	x
	avg	12,83	No	16,41	Yes	x	3,00	to small
15	#1	14,14	No	12,91	No	17,00	7,00	to small
	#2	13,36	No	14,00	No	17,14	7,00	to small
	#3	13,03	No	13,97	No	17,70	6,50	to small
	avg	13,51	No	13,63	No	17,28	6,83	to small
25	#1	13,80	No	14,91	No	14,34	x	Yes
	#2	13,40	No	14,34	No	14,32	x	Yes
	#3	14,00	No	14,74	No	15,62	x	Yes
	avg	13,73	No	14,66	No	14,76	x	Yes

Table 13 Results drainage test.

### Conclusion

The tube with the inside diameter of 6 mm is too small to drain the water. Only at the height of 25 cm can the water be drained without overflowing the buffer. However, if a user would urinate more or faster than average it would become a problem. The 7 mm tube can drain the water at all three heights. At the height of 5 cm, it takes the longest (16 sec) and the buffer is (visibly) needed 2 out

of 3 times. At the height of 15 and 25 cm, it takes between 13-14 seconds to drain. This shows that the height difference between the capturing and drainage has a small influence on the speed. The 8 mm tube did not (visibly) need the buffer and was able to properly drain the water at all three heights with a speed between 13 and 14 seconds. Therefore this diameter is the safest option to choose.

## Appendix 14 Concept evaluation test

*The main purpose of the concept evaluation test is to test the comfort of the product because the usability of the product depends on it. The product must be suitable for long-term use. The comfort and tactility of different parts of the product are mapped to identify possible areas for improvement. The second part that important for product usability is its functionality, which refers to the urine drainage. This Appendix includes the method, set-up, and answer sheet of the evaluation tests. the test results and conclusion can be found in chapter 4.3.*

### **Necessities**

- » Altered Lewis orthosis
- » prototype (product, tube, toplayer, container)
- » Question form
- » Timer
- » Connection material
- » bucket
- » Stool
- » foam

### **Method**

The comfort test consists of 3 steps. An explanation for each step is given. The comfort test was conducted by the client and the functionality test was conducted by the student, where relevant this will be mentioned.

### **STEP 1 - PREPARATIONS**

1. Install the seat on the wheelchair
2. Check if the location of the product on the seat is good, the current was based on a quick test. It may need to be moved slightly forward or backward. If so, the following steps need to be taken:
  1. Find out how much the product should move forward or backward
  2. Deassemble the orthosis
  3. Resize the foam pieces
  4. Reassemble the orthosis and place back
  5. Check if the location is good
3. Place the top layer over the seat, this is made extra long at the front and back. based on the final location, it can be cut to size.
4. After taken these steps, fill in the answer at the question form regarding step 1.

### **STEP 2- TESTING THE COMFORT AND FUNCTION**

The first part of the test is to test the comfort. The goal is to sit as long on the prototype as possible. Focus during the test on the comfort of the product in three different areas.

1. Once seated on the prototype, start the timer or make a note of the time.
2. Based on your own expectation, decide to rate the comfort of the three areas every hour or halfhour. Fill in on the form. Write per area whether it is perceptible (regardless of whether it is comfortable or not). If an area is perceptible, rate the comfort of the area. The comfort may decrease the longer you sit on it.

3. When leaving the prototype, stop the timer and or make a note of the time.
4. After taken these steps, fill in the answer at the question form regarding step 2.1.

The second part of the test will test the functionality. Test this with and without the toplayer. Because this was conducted by the student, without the orthosis some extra steps were needed:

1. Find or make a surface at an angle between 12 and 20 degrees.
2. Place the prototype inside the foam
3. Place both foam and prototype on the surface
4. Place a bucket under the tube
5. Sit on the prototype
6. Urinate, try to do this as natural as possible. do this both with and without the toplayer
7. After taken these steps, fill in the answer at the question form regarding step 2.2.

### **STEP 3 - EVALUATION**

After conducting the test, the results will be discussed in conversation between client and student.

### **Results**

The answers to the question form are given on the next page. The full results are mentioned in chapter 4.3.

# Invulformulier

## A Voorbereidingen (CLIENT)

1 Hoe eenvoudig/moeilijk was het om de juiste locatie voor het product te vinden?

Dit ging bij het huidige prototype niet goed, omdat de locatie nog niet correct was.  
Aanbeveling: Lewis heeft beelden van mijn zitvlak op het kussen. Die beelden gebruiken om het product goed te localiseren. Voor mij is het fysiek te vermoeiend om het steeds opnieuw te proberen.

Het flapje dat bedoeld is om over de opening te gaan verdwijnt bij het gaan zitten. Aanbeveling: Laat een echt goede naaister een perfect passende vorm maken die ruim over de tuit uitsteekt en misschien zelfs vast te zetten is, zodat hij blijft zitten.

3-d weefsel toplaag: deze moet makkelijk vast te zetten zijn, zodat hij niet verschuift tijdens het positioneren, maar wel eenvoudig weer verwijderd kan worden.

2 Was is je eerste gevoel over het product? Zijn er dingen die meteen opvallen of die je voelt?

Aanbeveling: Nadenken over toch verzinken van product in schuim zodat de randen niet voelbaar zijn.

## B Comfort test (NOT CONDUCTED)

1 Gaan zitting op de zitting om \_\_\_\_\_uur, en van de zitting afgegaan om \_\_\_\_\_uur.

2 Hoe ging het plaats nemen op het product. Was het meteen goed of moest je nog wat doen om helemaal goed en comfortabel te zitting.

3 Comfort per gebied (zie figuur), gebruik hiervoor de schaal van 1 tot 5. Geef als eerste aan of het gebied voelbaar is. Als het antwoord hierop ja is, vul dan ook de comfort schaal in. Zet een X neer bij het bijbehorende cijfer. Omdat het comfort kan veranderen naar mate je langer op het product zit, probeer daarom de schaal op verschillende momenten in te vullen.

- 1 No pain = feel it, but not unpleasant
- 2 Mild pain = can be ignored
- 3 Moderate = interferes with tasks
- 4 bad pain = interferes with concentration
- 5 severe pain = interferes with basic need

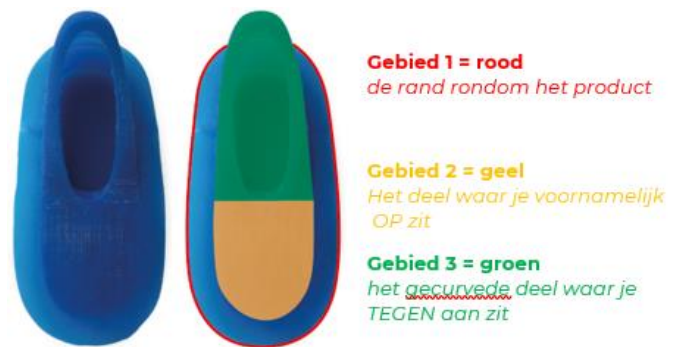

Voorbeeld :

Gebied 1	Is dit gebied voelbaar JA/Nee				
Indien ja	No pain	Mild pain	Moderate	Bad pain	Severe pain
	1	2	3	4	5
		X			



Moment 1 → om \_\_\_\_ : \_\_\_\_ uur

<b>Gebied 1</b> Is dit gebied voelbaar JA /Nee					
<i>Indien ja</i>	No pain	Mild pain	Moderate	Bad pain	Severe pain
	1	2	3	4	5
<b>Gebied 2</b> Is dit gebied voelbaar JA /Nee					
<i>Indien ja</i>	No pain	Mild pain	Moderate	Bad pain	Severe pain
	1	2	3	4	5
<b>Gebied 3</b> Is dit gebied voelbaar JA /Nee					
<i>Indien ja</i>	No pain	Mild pain	Moderate	Bad pain	Severe pain
	1	2	3	4	5

Moment 2 → om \_\_\_\_ : \_\_\_\_ uur

<b>Gebied 1</b> Is dit gebied voelbaar JA /Nee					
<i>Indien ja</i>	No pain	Mild pain	Moderate	Bad pain	Severe pain
	1	2	3	4	5
<b>Gebied 2</b> Is dit gebied voelbaar JA /Nee					
<i>Indien ja</i>	No pain	Mild pain	Moderate	Bad pain	Severe pain
	1	2	3	4	5
<b>Gebied 3</b> Is dit gebied voelbaar JA /Nee					
<i>Indien ja</i>	No pain	Mild pain	Moderate	Bad pain	Severe pain
	1	2	3	4	5

Moment 3 → om \_\_\_\_ : \_\_\_\_ uur

<b>Gebied 1</b> Is dit gebied voelbaar JA /Nee					
<i>Indien ja</i>	No pain	Mild pain	Moderate	Bad pain	Severe pain
	1	2	3	4	5
<b>Gebied 2</b> Is dit gebied voelbaar JA /Nee					
<i>Indien ja</i>	No pain	Mild pain	Moderate	Bad pain	Severe pain
	1	2	3	4	5
<b>Gebied 3</b> Is dit gebied voelbaar JA /Nee					
<i>Indien ja</i>	No pain	Mild pain	Moderate	Bad pain	Severe pain
	1	2	3	4	5

4 Wat waren je ervaringen met het zitten op het product? Zijn er veranderingen die je zou doen aan het product en wat? Denk bijvoorbeeld aan de vorm en curve van uit uitstekende deel.

---

---

5 Was het nodig om af en toe te bewegen of te schuiven op de zitting om comfortabel te blijven?

---

---

6 Hoe ging de transfer uit de stoel aan het eind van de test. Kon je over het product heen schuiven?

---

---

7 De toplaag ligt nu los op het product, is dit voldoende of zou deze nog extra aan de zitting bevestigd moeten worden? Denk hierbij aan bijvoorbeeld klittenband of elastiek.

---

---

8 Maskeert de toplaag het gevoel van op een opening zitten? En hoe voelt de toplaag aan?

---

---

9 Ruimte voor overige opmerkingen:

---

---

---

### **C Functionaliteit (STUDENT)**

1 Ik heb het product **2** keer gebruikt. \* een keer met en een keer zonder top laag

2 a. Urineren met de top laag, dit functioneerde **WEL/NIET** goed.

2 b. Urineren zonder de top laag, dit functioneerde **WEL/NIET** goed.

3 Hoe voel /ervaar je het gebruik van het product? Is het prettig in gebruik of vergt het bijvoorbeeld wat oefening?

Het was in het begin een beetje onwennig, omdat ik niet gewend was aan het product. Ik had het gevoel dat ik langer ging urineren om meer controle te hebben over wat er ging gebeuren. Ik denk dat het product wat oefening vergt. En dat je als gebruiker eerst vertrouwen in het product moet krijgen voordat het echt comfortabel wordt in gebruik.

4 Wat was het verschil in ervaringen met zonder de top laag tijdens het urineren?

Zonder de top laag functioneerde het product goed, ik had het gevoel dat ik goed op het product zat en door de opening heen urineerde. Dit gaf een gevoel van controle. Zonder de top laag was het gevoel van controle aanzienlijk minder, naast dat het er ook naast liep. De ervaring was daardoor niet prettig.

3 Hoe voelde de top laag aan na het plassen? Nat/droog comfortabel/oncomfortabel

Nat, omdat het door naar achteren liep.

4 Had je het gevoel dat de urine snel genoeg weg liep?

Zonder top laag had ik het gevoel dat het goed weg liep. Opmerkelijk was dat toen ik van het prototype op stond er nog een klein beetje urine uit de slang kwam lopen. Waarschijnlijk zat dit ergens klem doordat ik op het product zat.

5 Kon je op een natuurlijk manier urineren of had je het gevoel of de neiging om in te houden of je aan te passen aan het product

Ik had de neiging om langzamer te urineren.

