

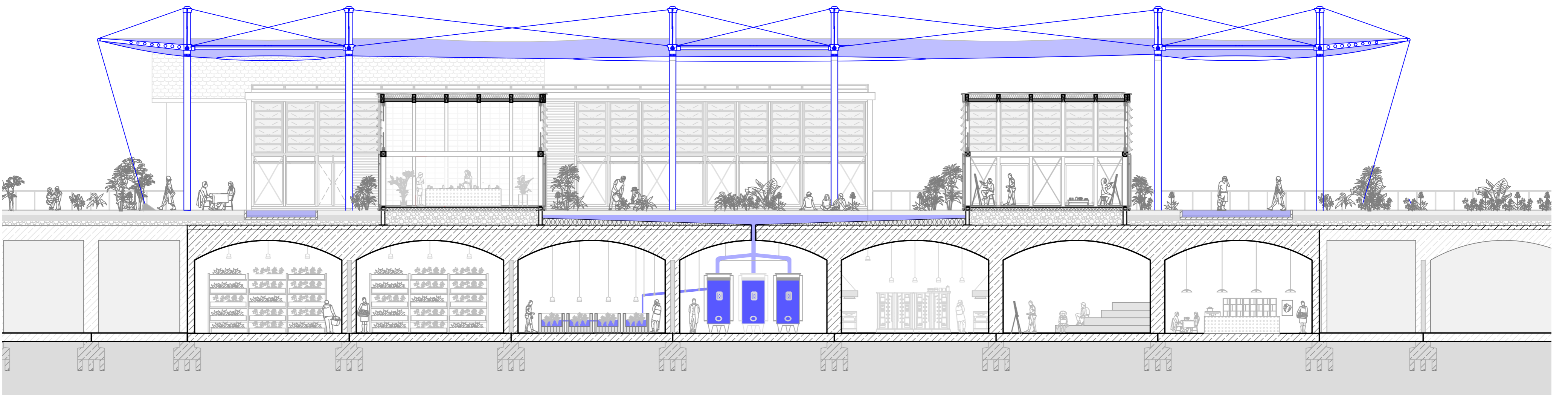

EUDOKIAPLEIN VIEW

THE BERGWEG WATER STATION



NORTH EAST SECTION 1:200

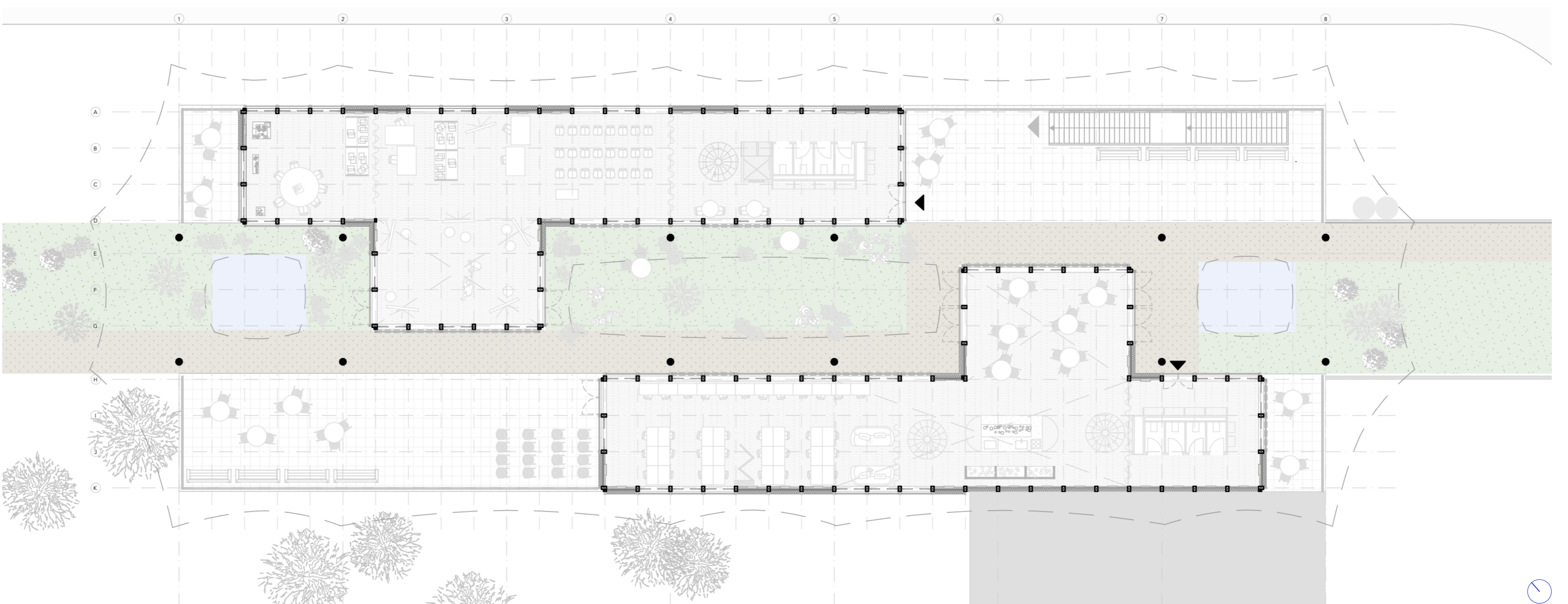

PLATFORM FLOORPLAN 1:200



PARKSPACE ON THE PLATFORM

LAYER OVERVIEW

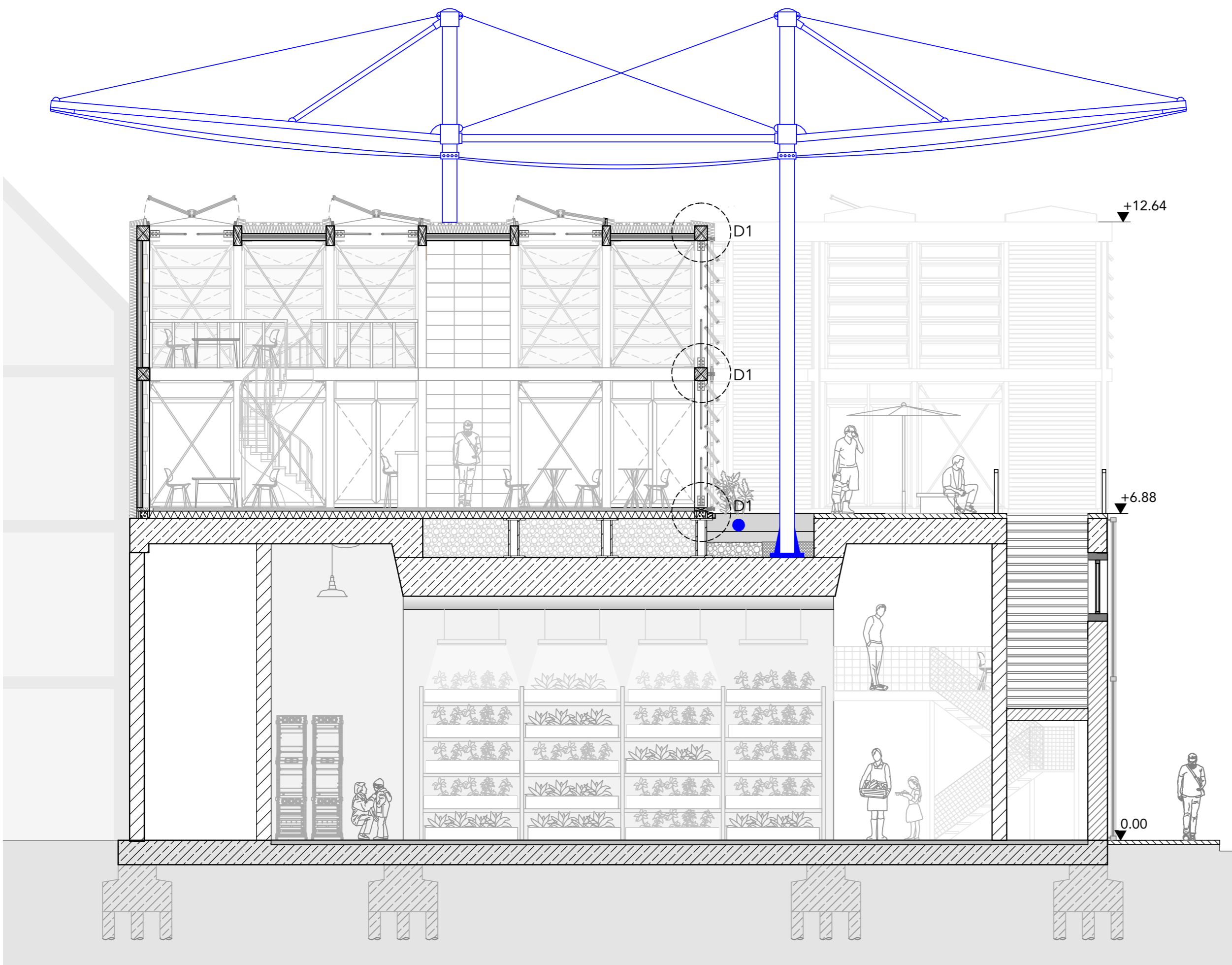
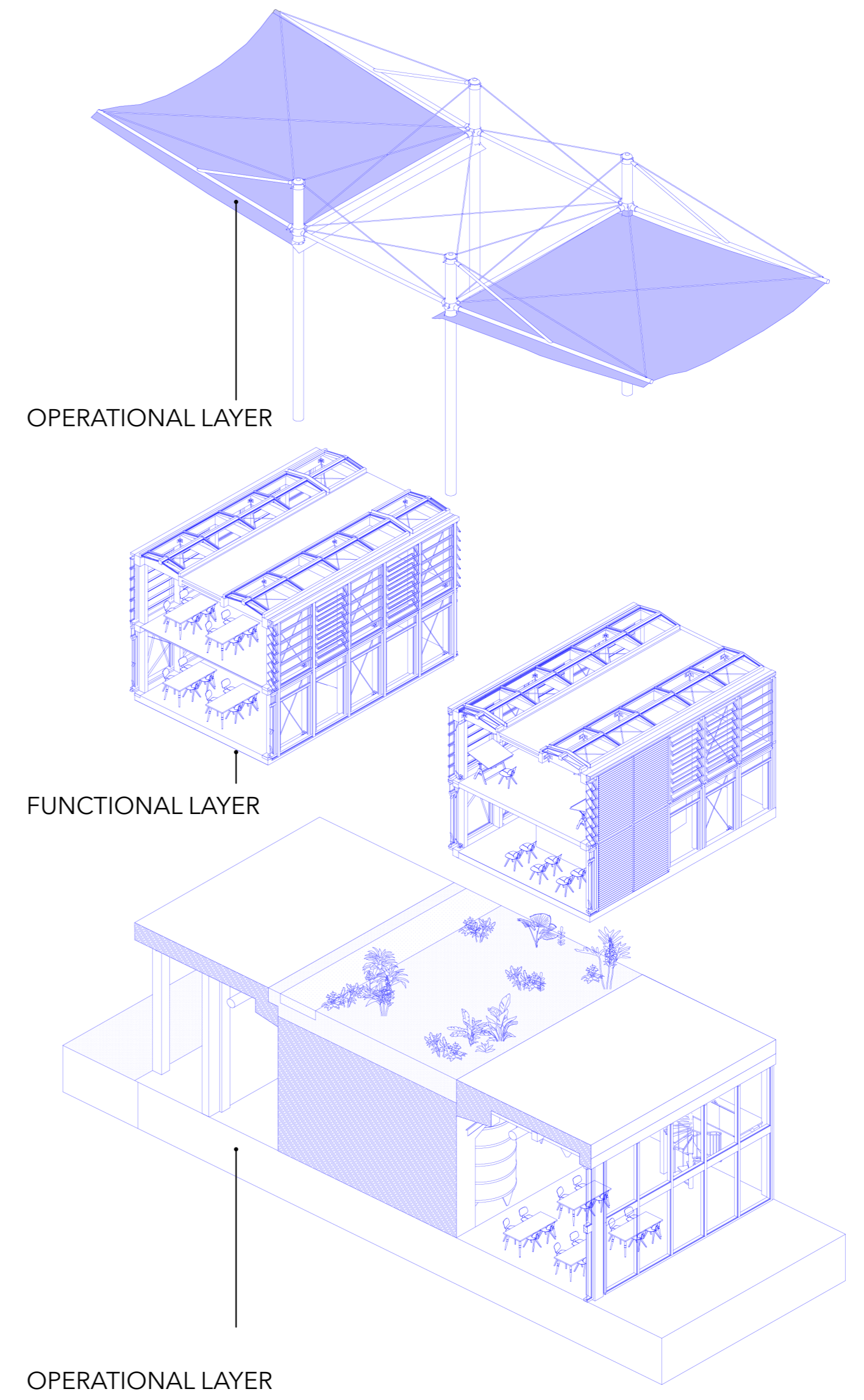

NORTH EAST SECTION 1:100

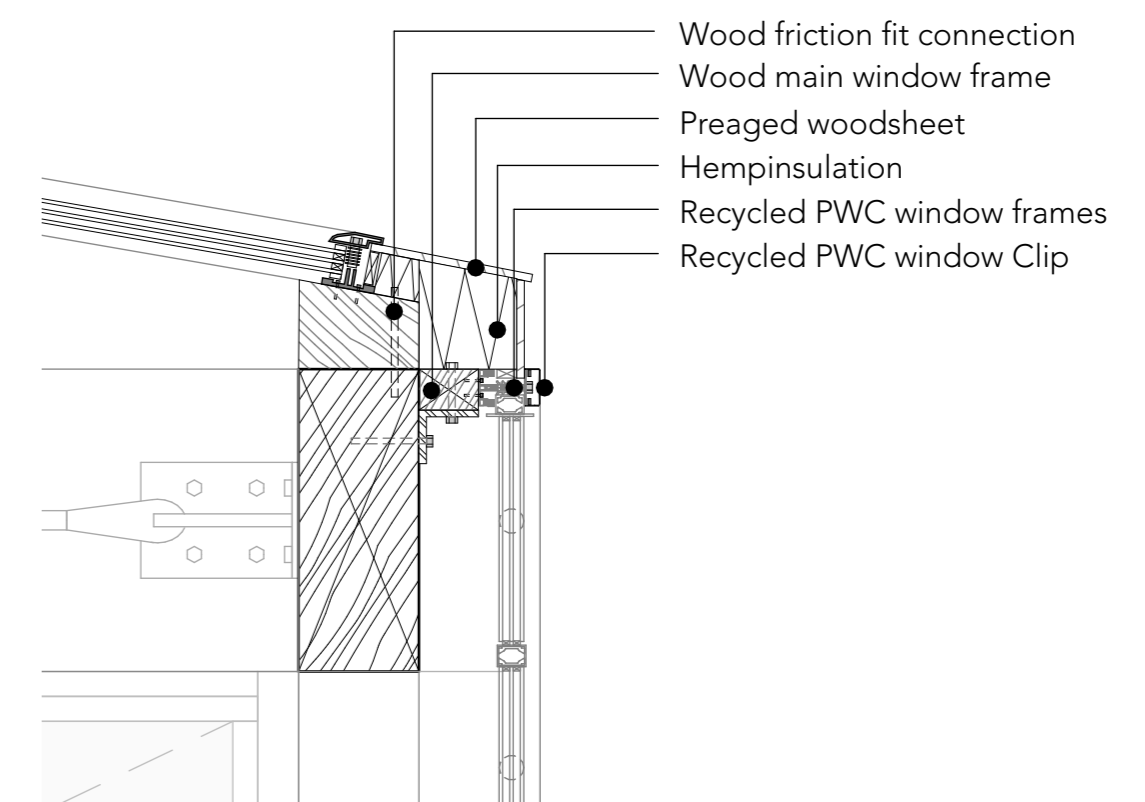

ROOF DETAIL 1:10

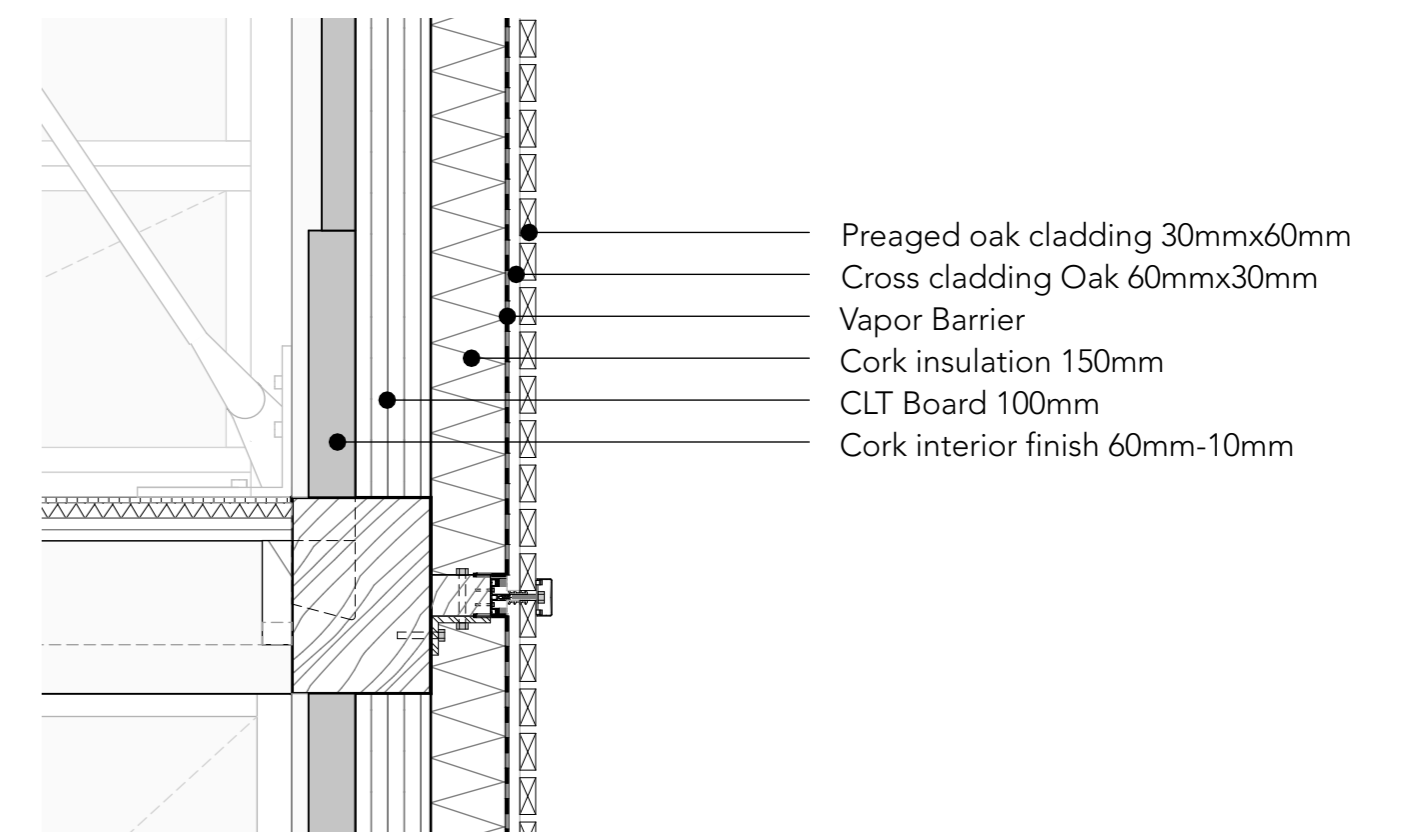

FACADE DETAIL 1:10

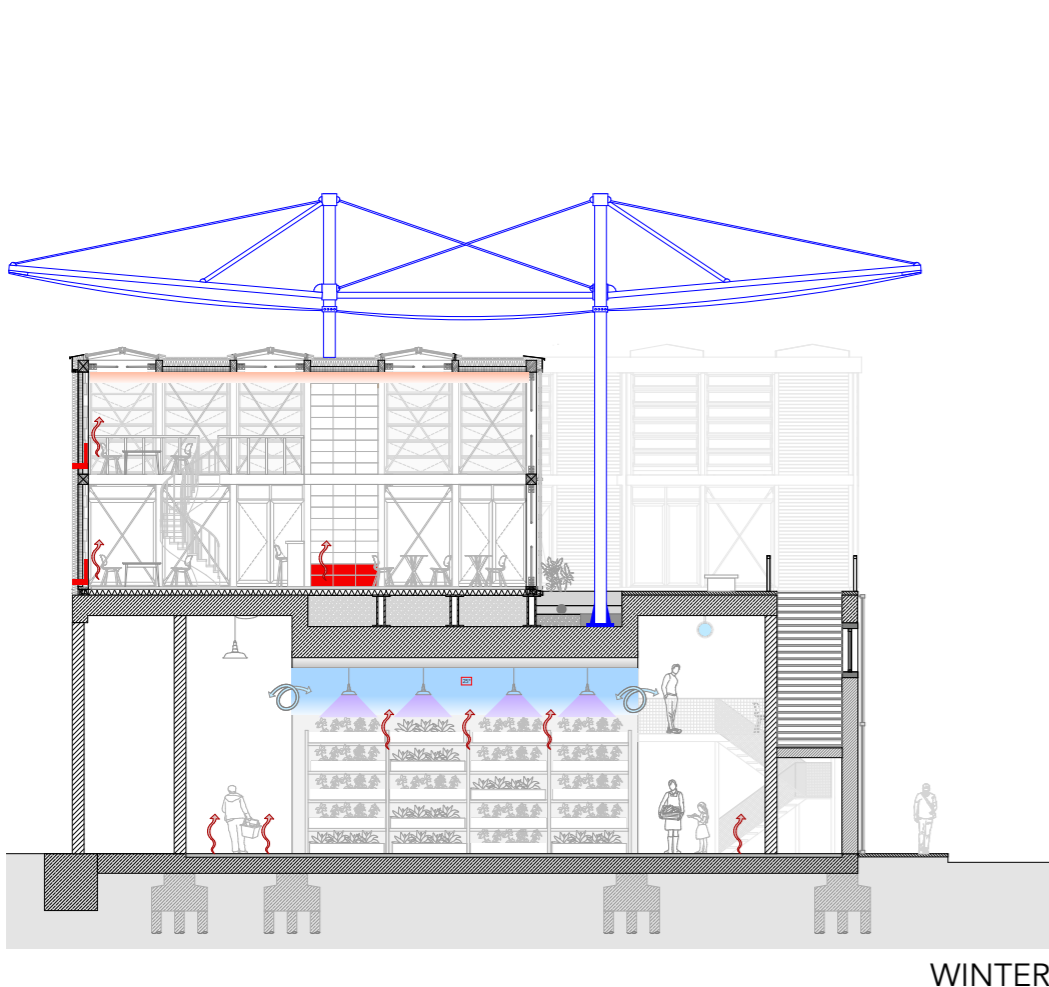

WINTER

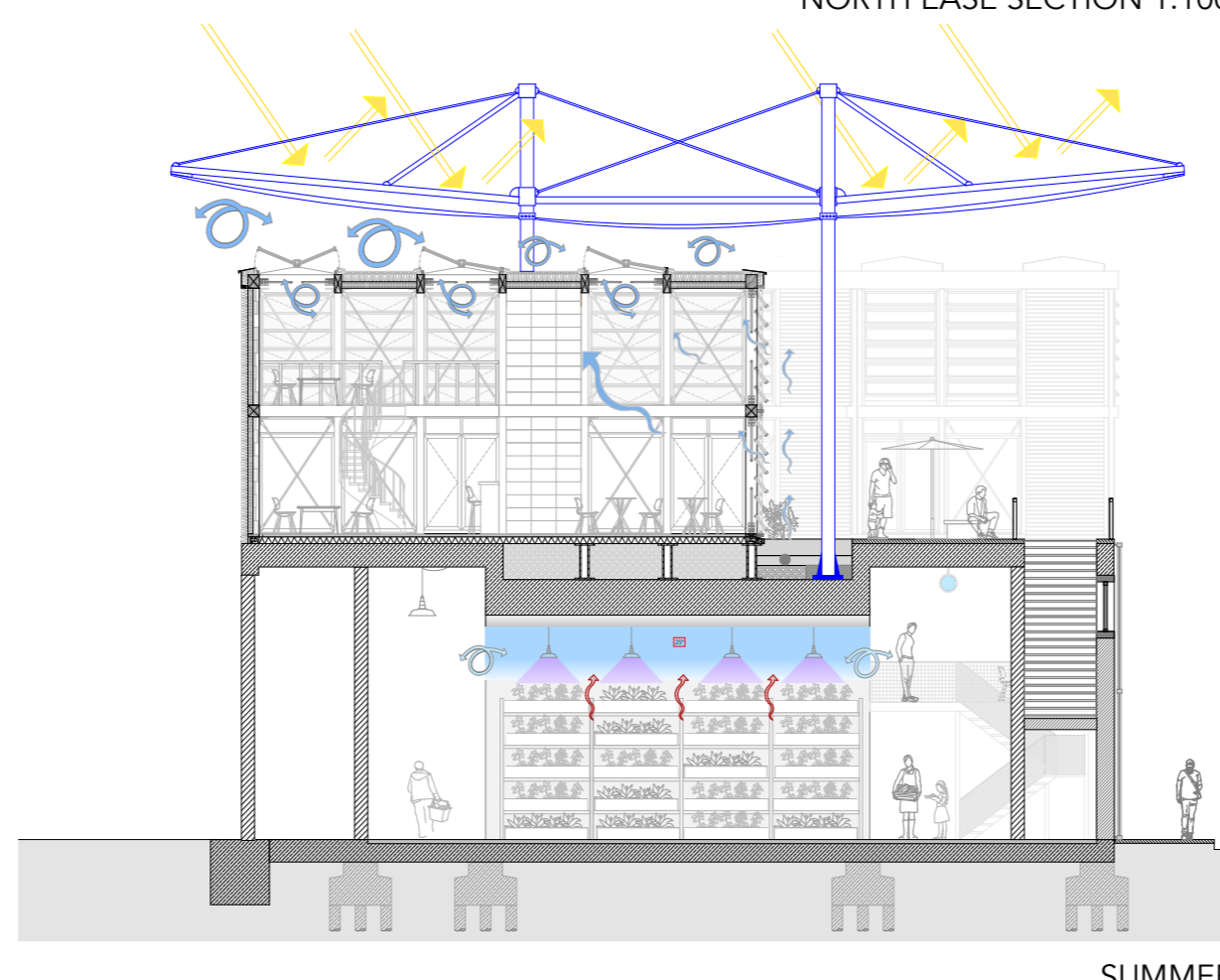

SUMMER

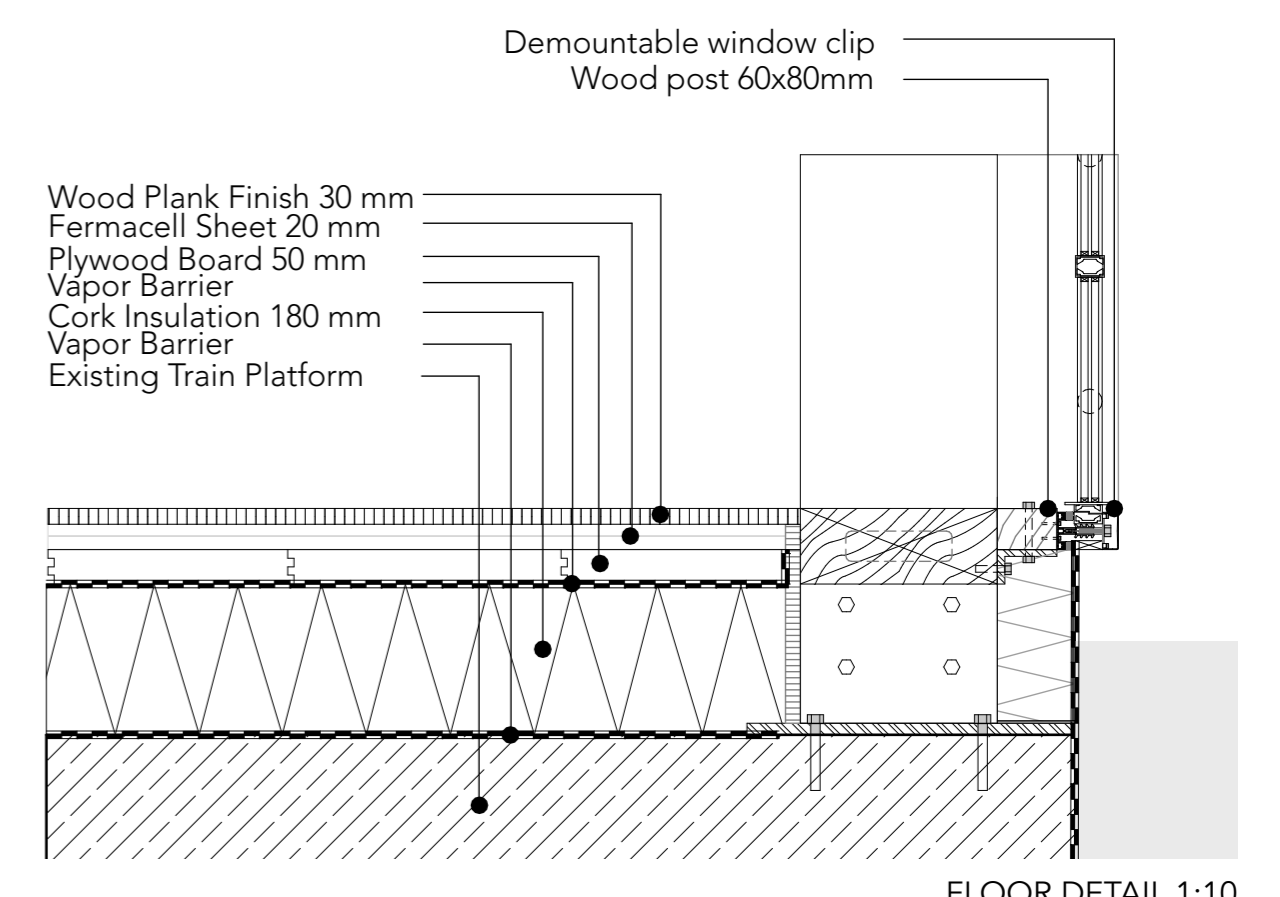

FLOOR DETAIL 1:10



WORKSHOP SPACE



CAFE & DIGITAL WORKSPACE

KIT OF PARTS

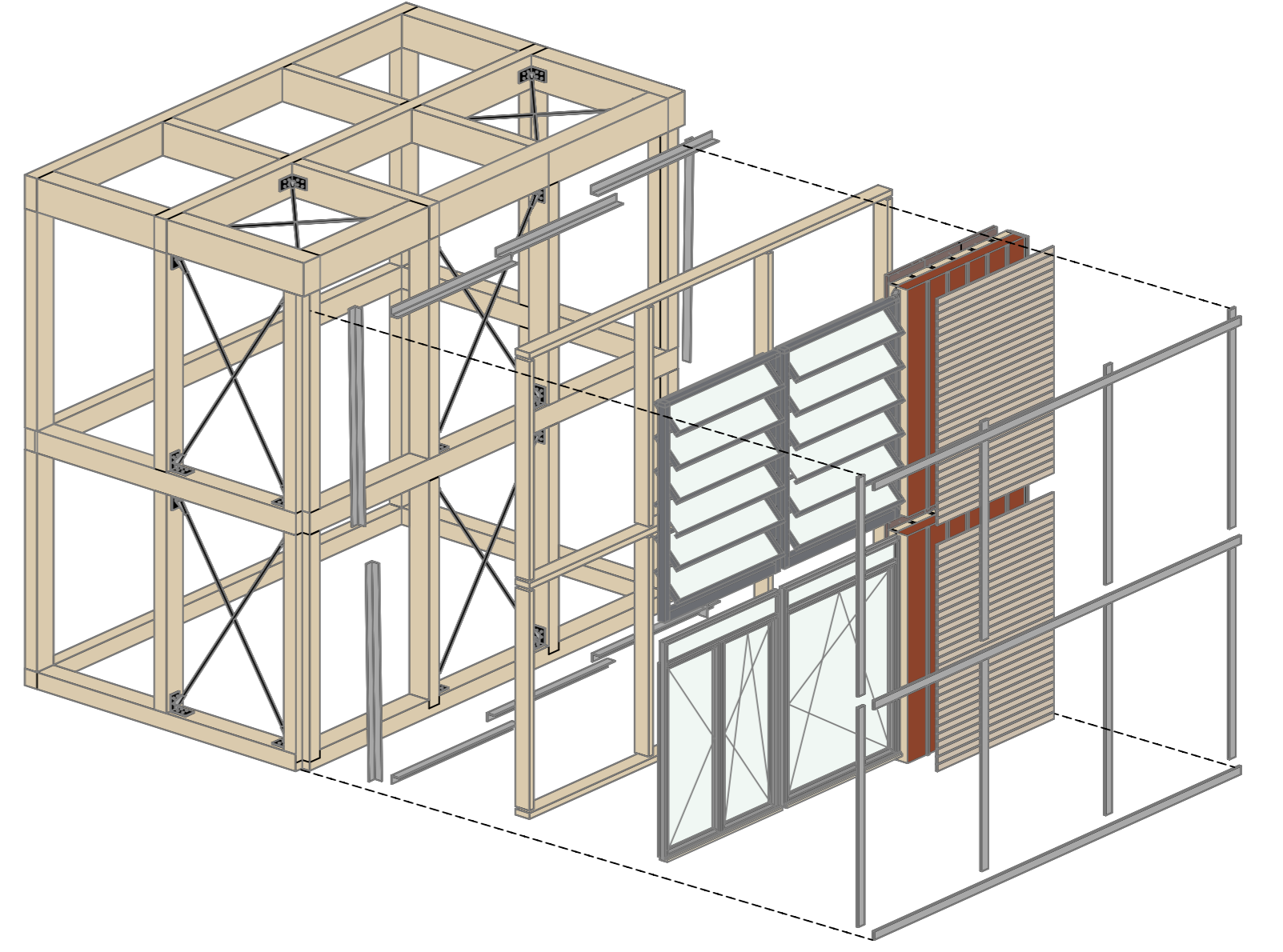

EXPLODED FACADE AXO

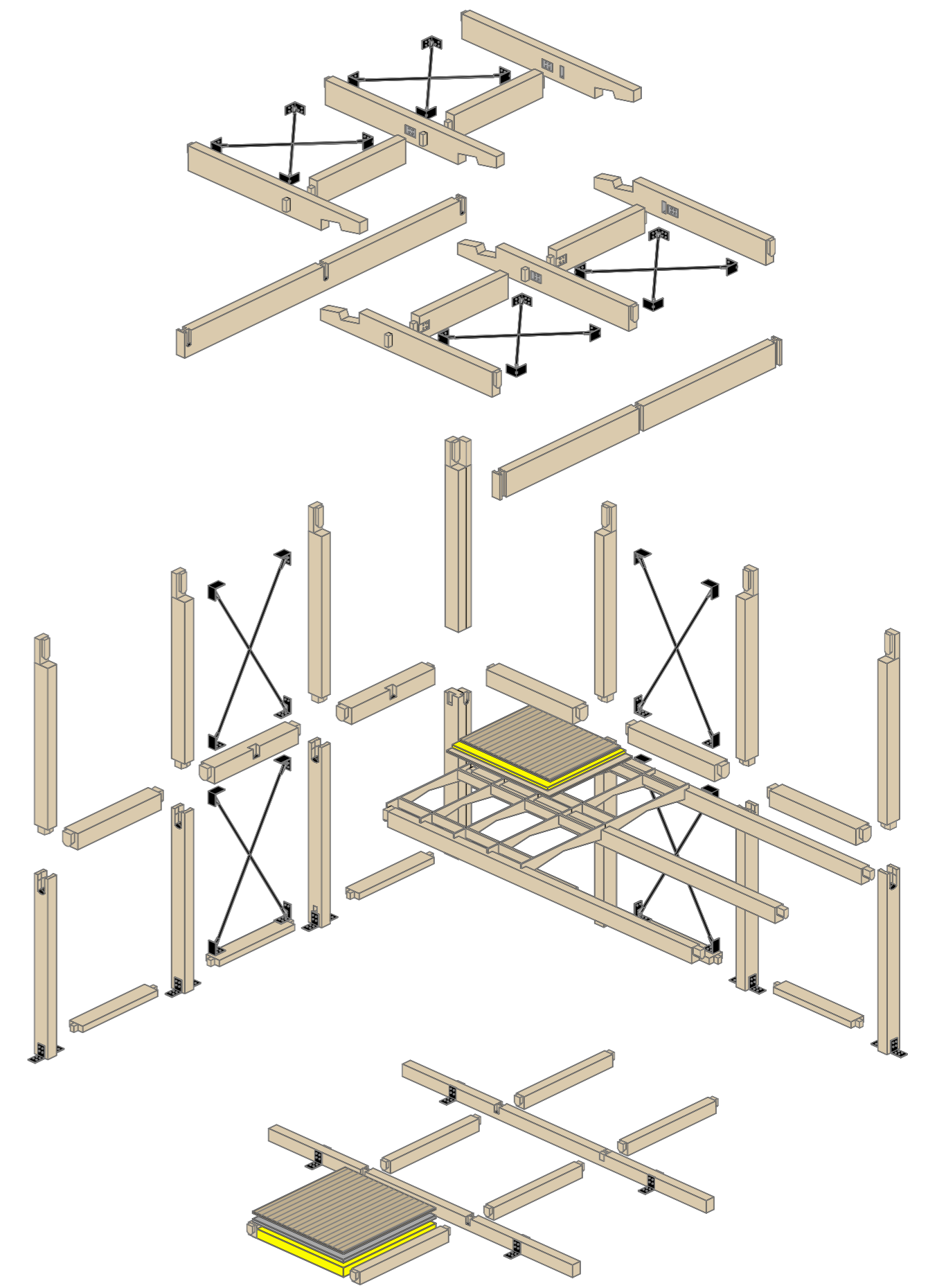

EXPLODED KIT OF PARTS

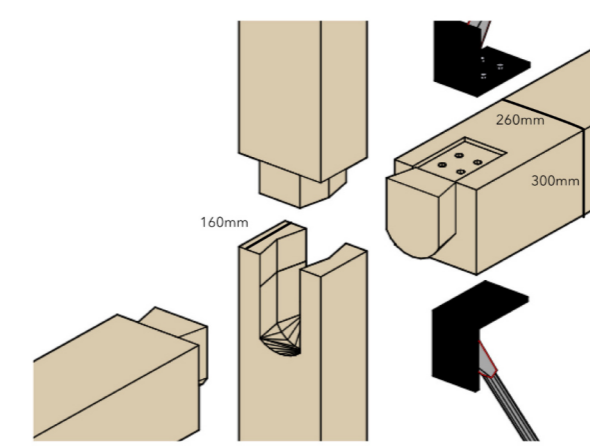

Post-beam connection of structure
90mm Dovetail

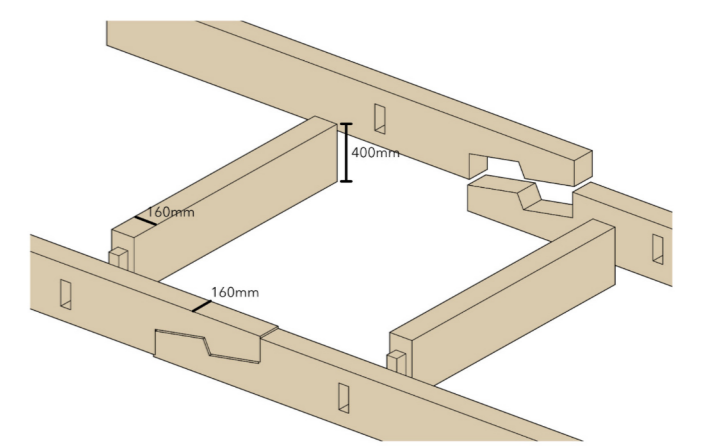

Ceiling beam connection
Mortise and Tenon + Scarf Joint

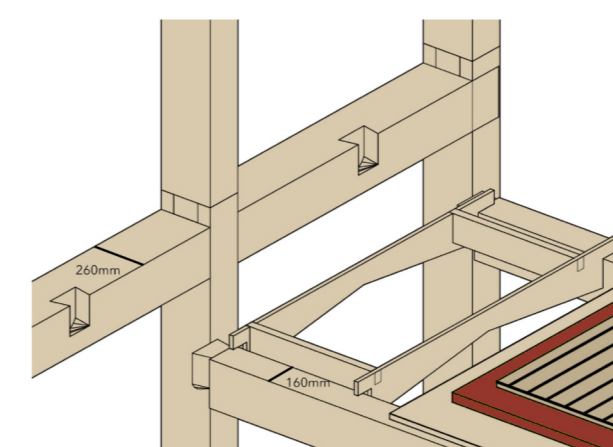

Interior ceiling and beam connection
Dovetail

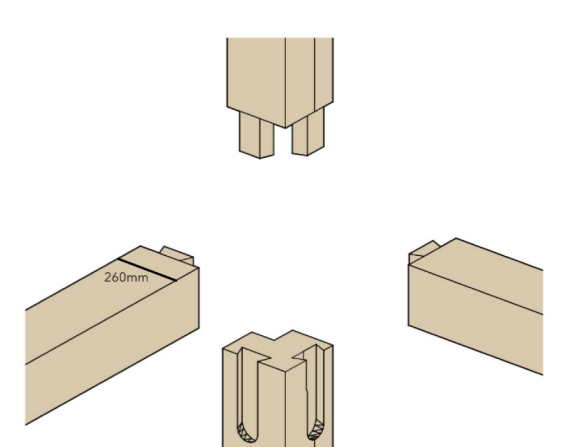

Beam + Post corner connection
Dovetail

THE BERGWEG WATER STATION

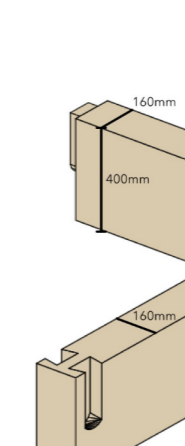

Ceiling beam to Post connection
Dovetail

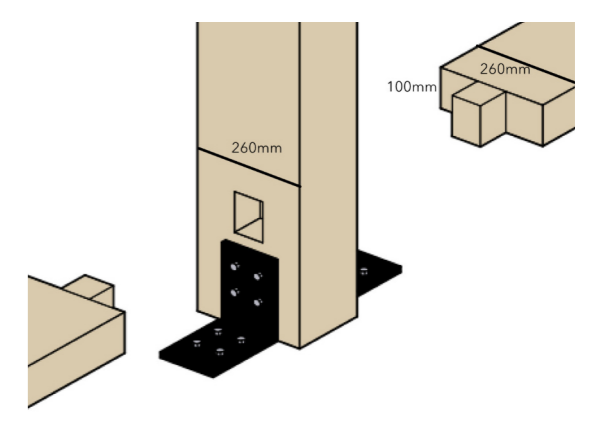

Post connection to ground
Mortise and Tenon

KIT OF PARTS DETAIL



WATER PONDS OF THE PARK

REPURPOSE STRATEGY

EMPIRICAL & TANGIBLE



DEFINE ROOFSPACE POTENTIAL



IDENTIFY EMPTY ROOFSPACE

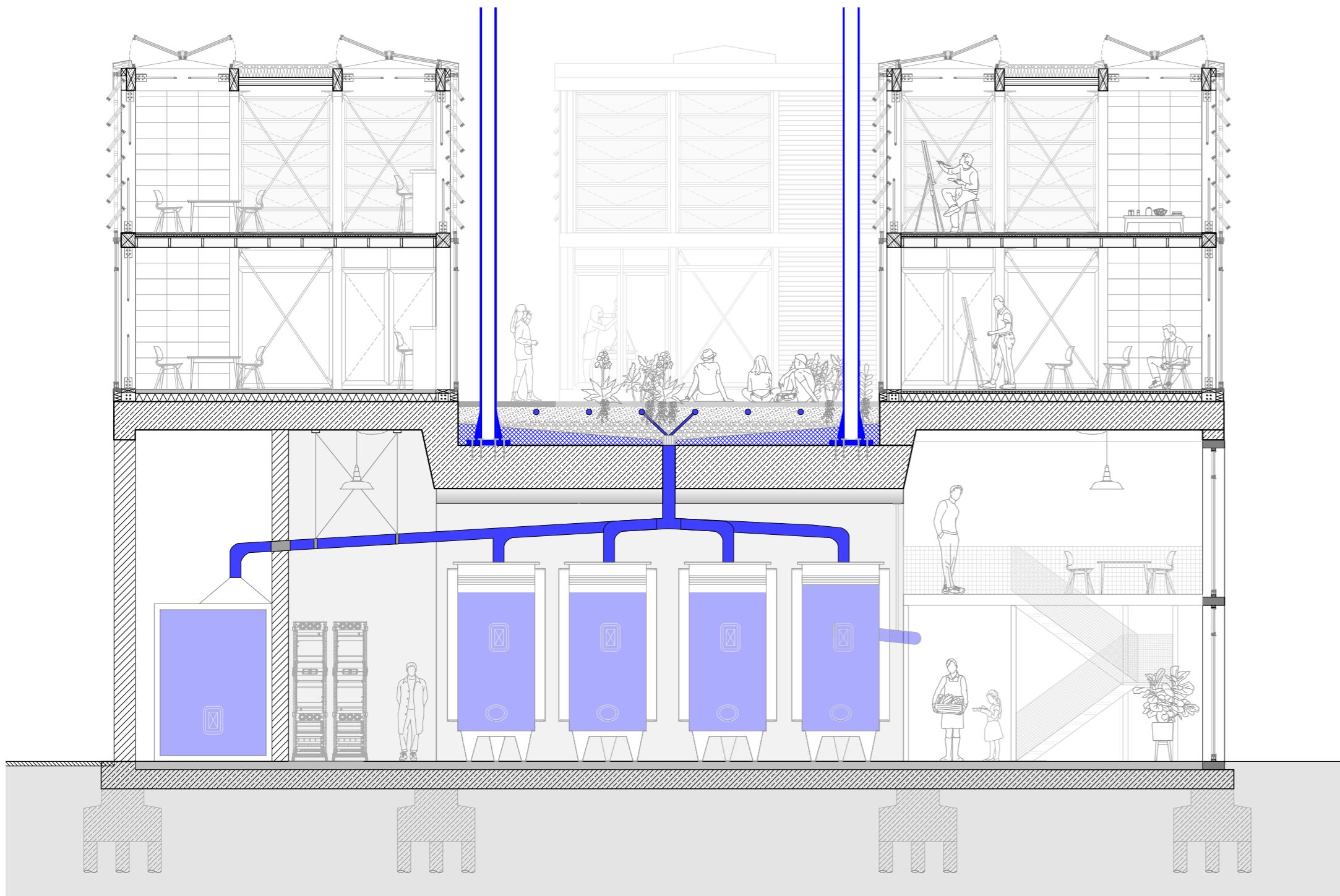
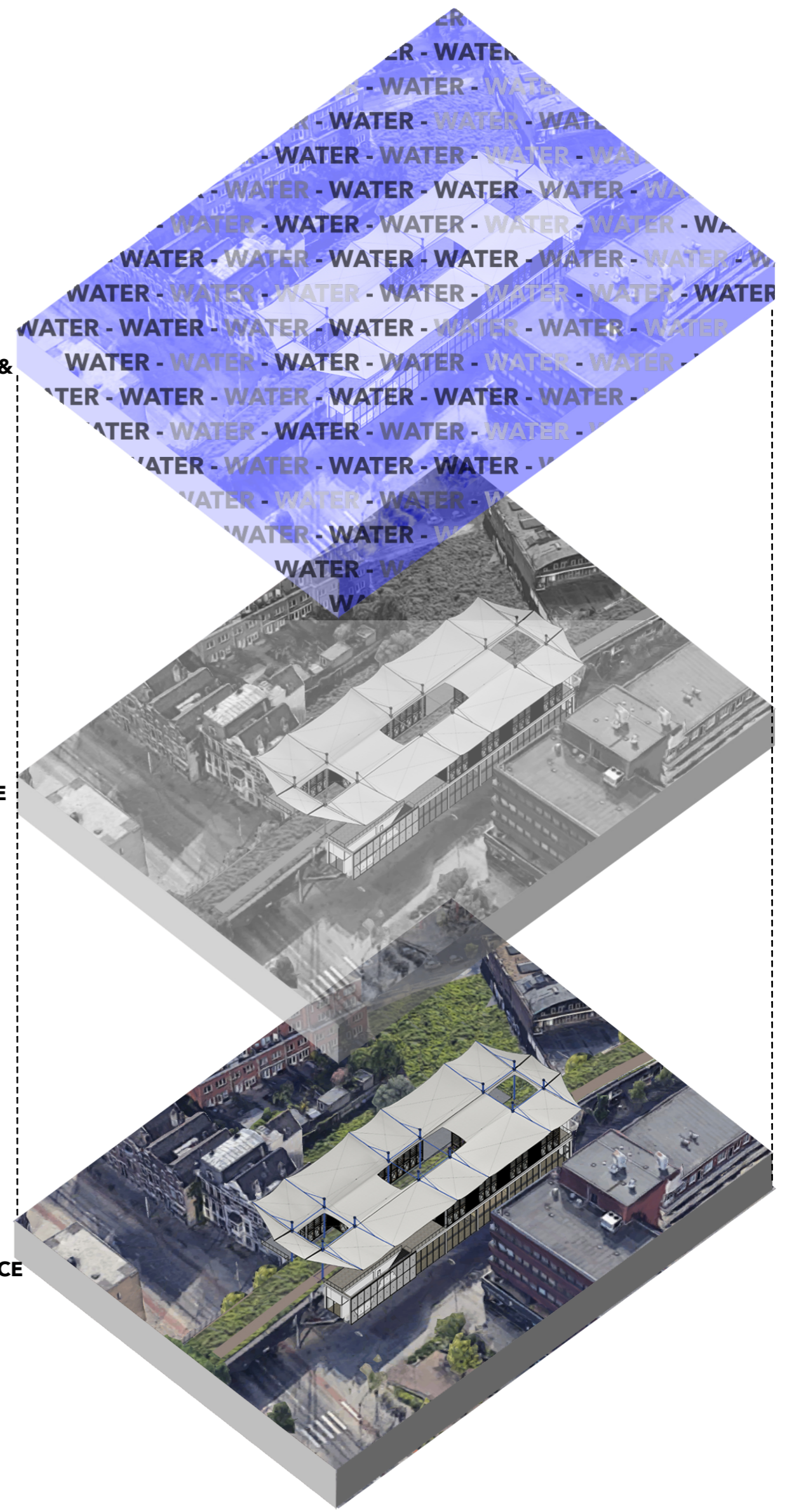

NORTH EAST SECTION 1:100

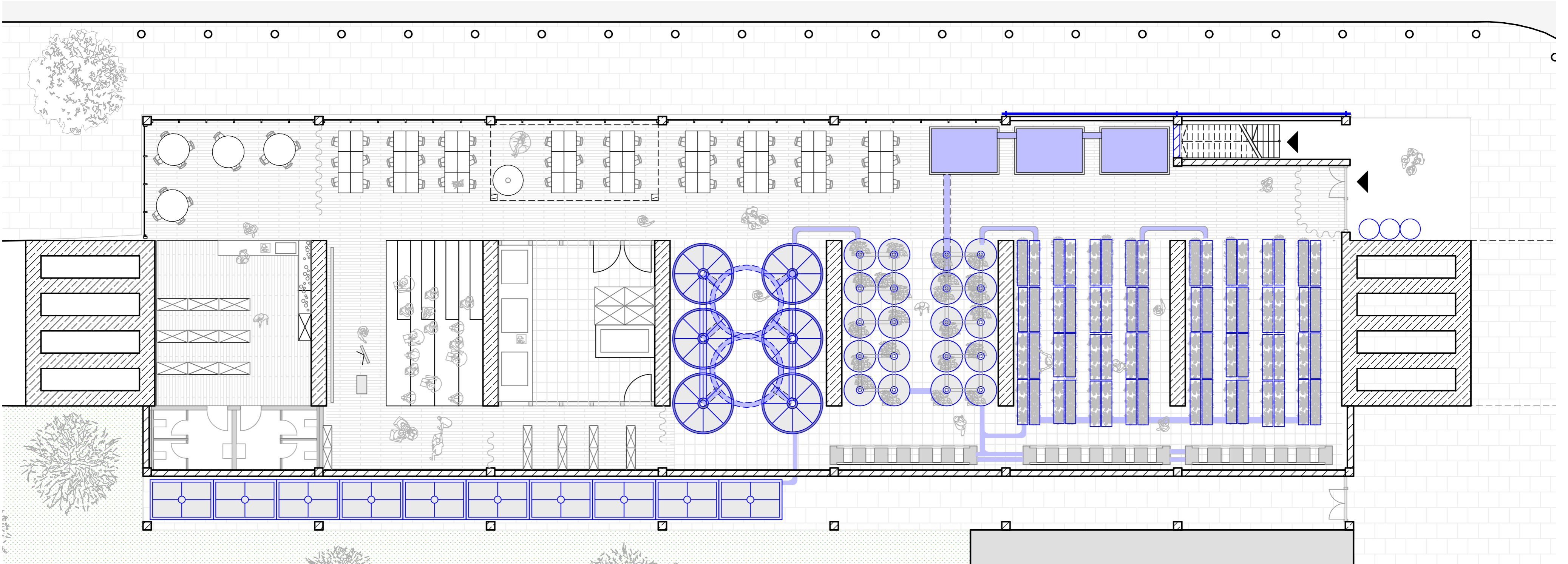
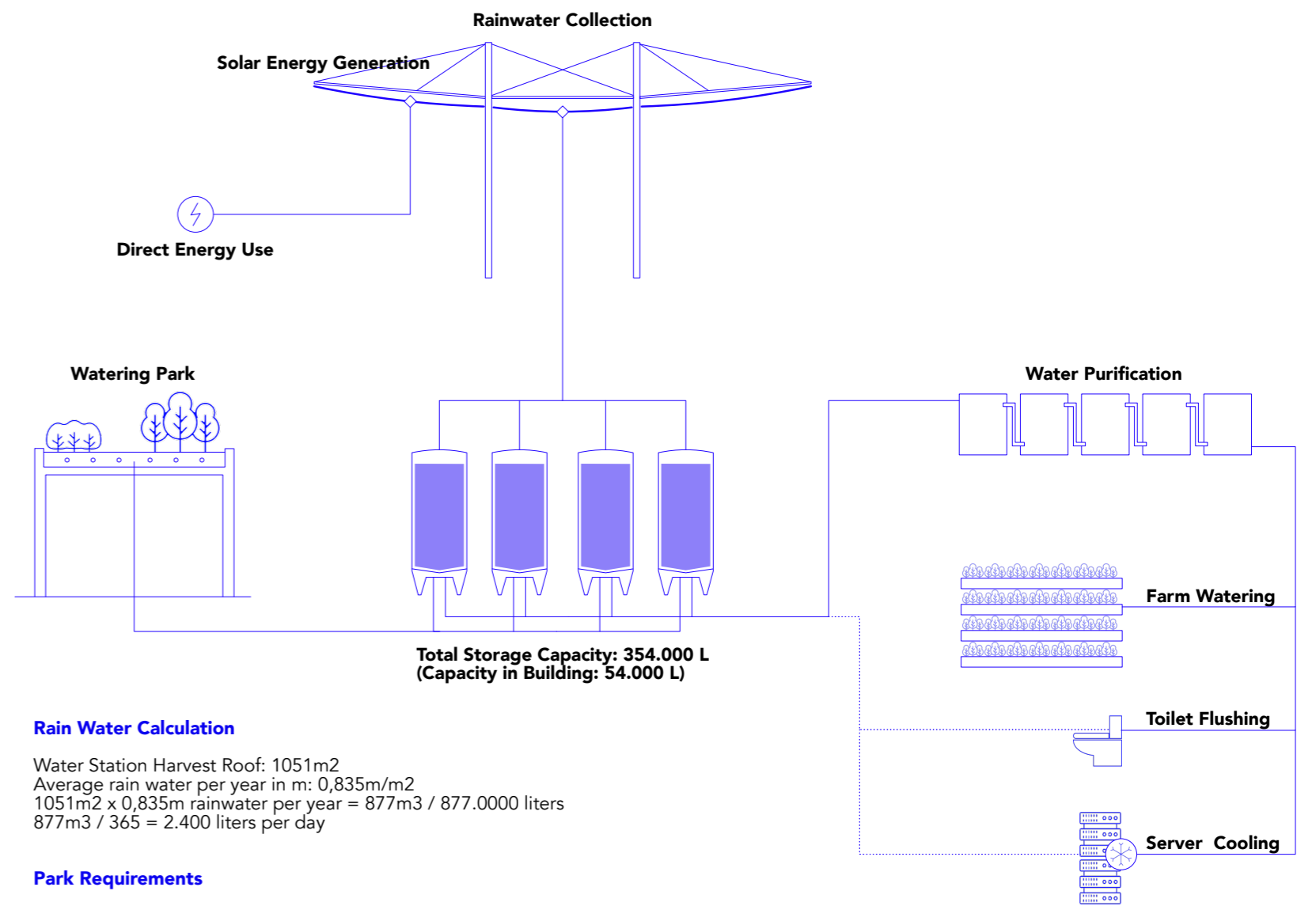

FLOORPLAN 1:200