

# **THE CIRCLE HUB**

## **The Cultural Social hub.**

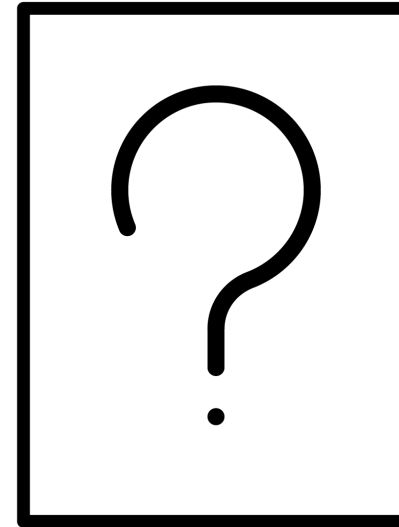

**PROBLEM STATEMENT**

Environment  
Neighborhood  
Social



amC

Universiteit van Amsterdam

# ENVIRONMENT





# ENVIRONMENT

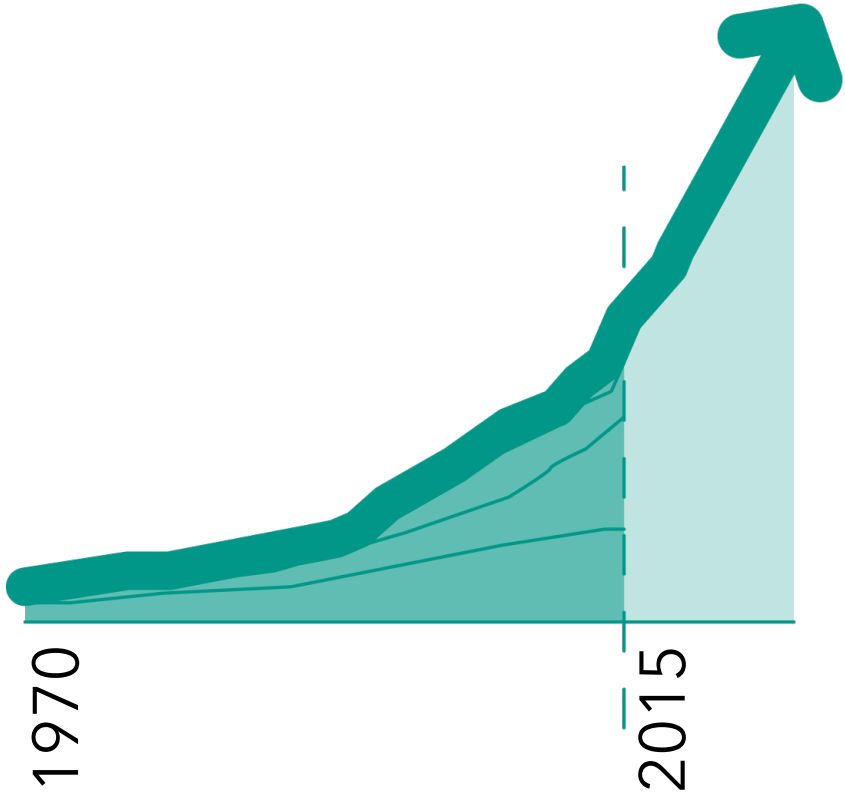

## MATERIAL CONSUMPTION

67% of current emissions are material related.  
Material use tripled from 1970 to 2015.



# ENVIRONMENT

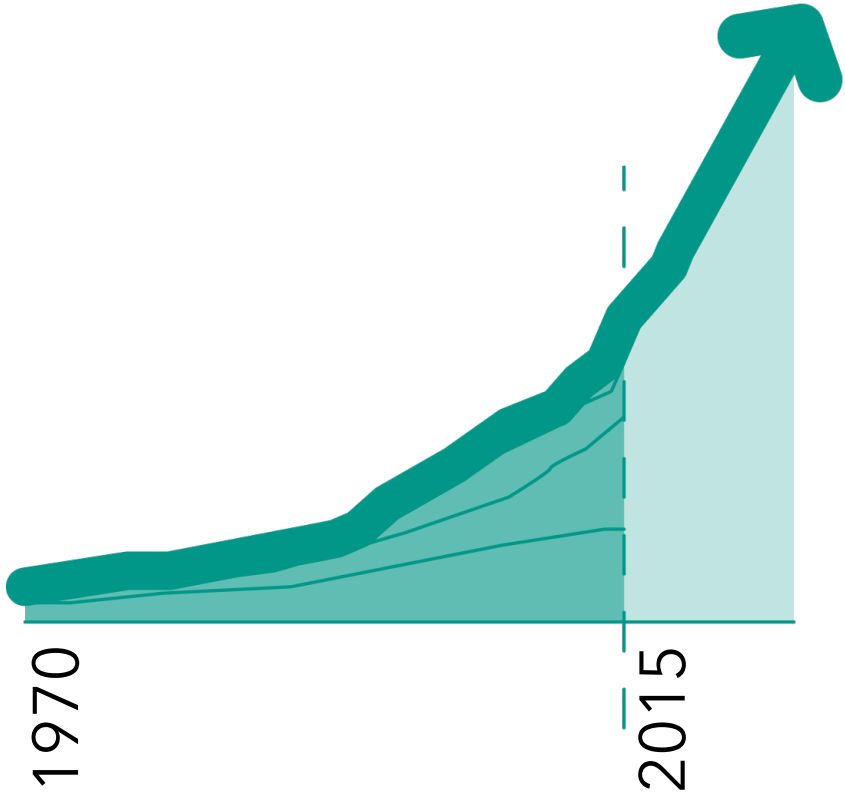

## MATERIAL CONSUMPTION

67% of current emissions are material related.  
Material use tripled from 1970 to 2015.

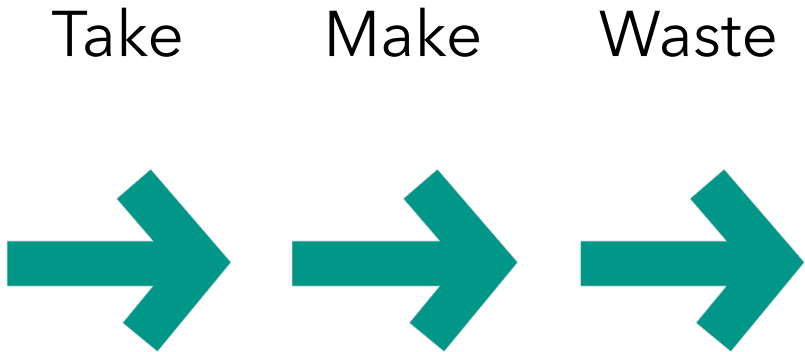

## LINEAR ECONOMY

Material is wasted.  
Consumption culture.



# ENVIRONMENT

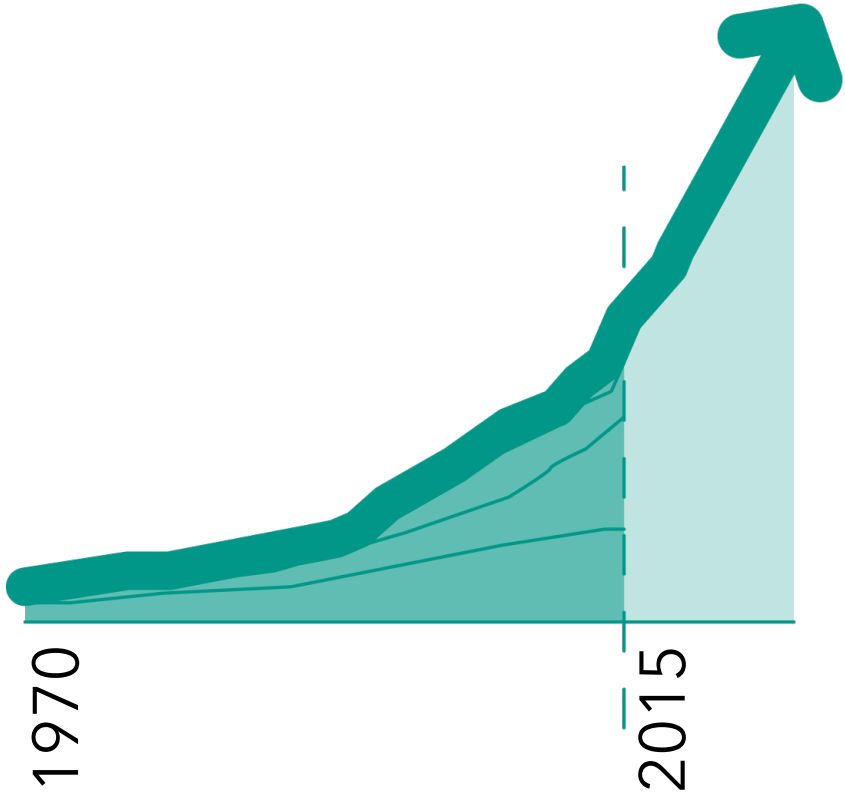

**MATERIAL CONSUMPTION**  
67% of current emissions are material related.  
Material use tripled from 1970 to 2015.

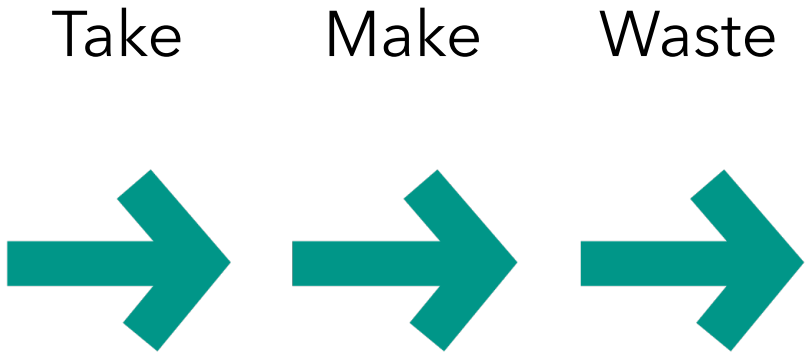

**LINEAR ECONOMY**  
Material is wasted.  
Consumption culture.

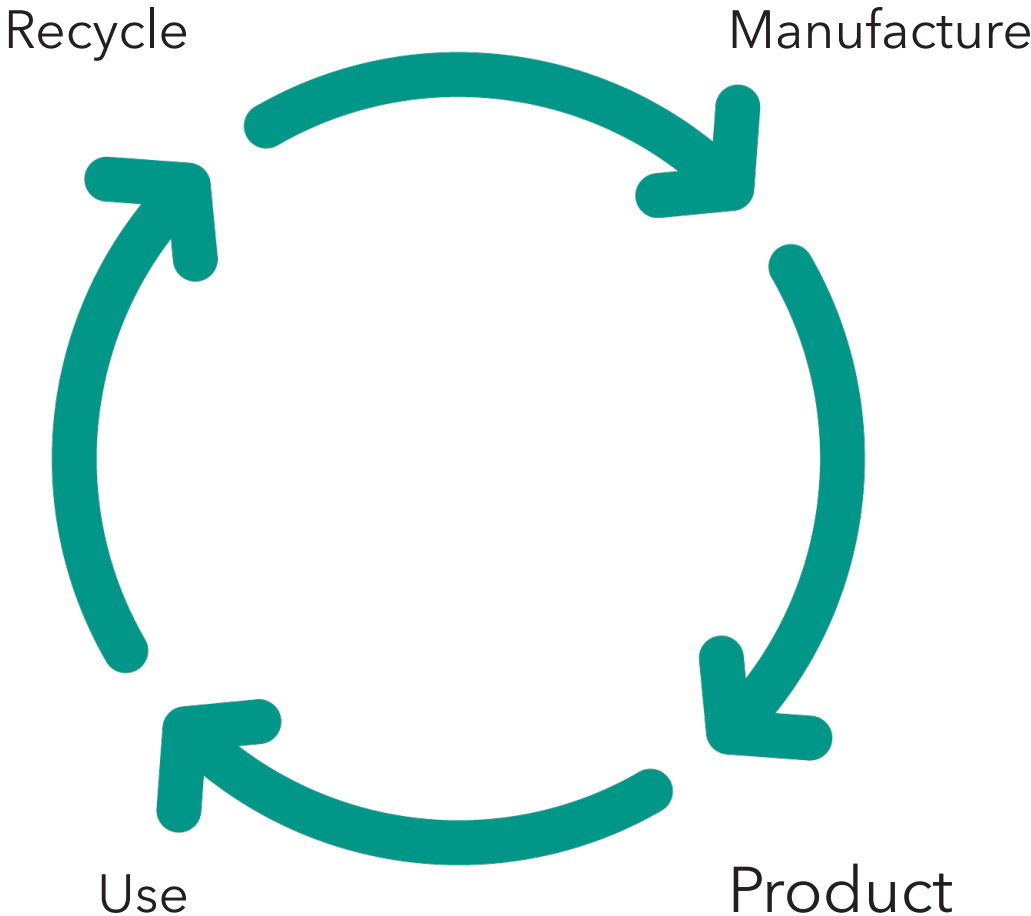

**CIRCULAR ECONOMY**  
Keep materials in loop.  
New Construction methods.



# NEIGHBORHOOD



## AMSTEL III NOW

Office district



# NEIGHBORHOOD



**AMSTEL III NOW**

Office district



**AMSTEL III VISION**

Mixed Urban City.



# NEIGHBORHOOD

To a Mixed Urban City.

Increased density :  
FSI 0.8 -> 2.3

Addition of public functions.



## AMSTEL III VISION

Mixed Urban City.



# SOCIAL

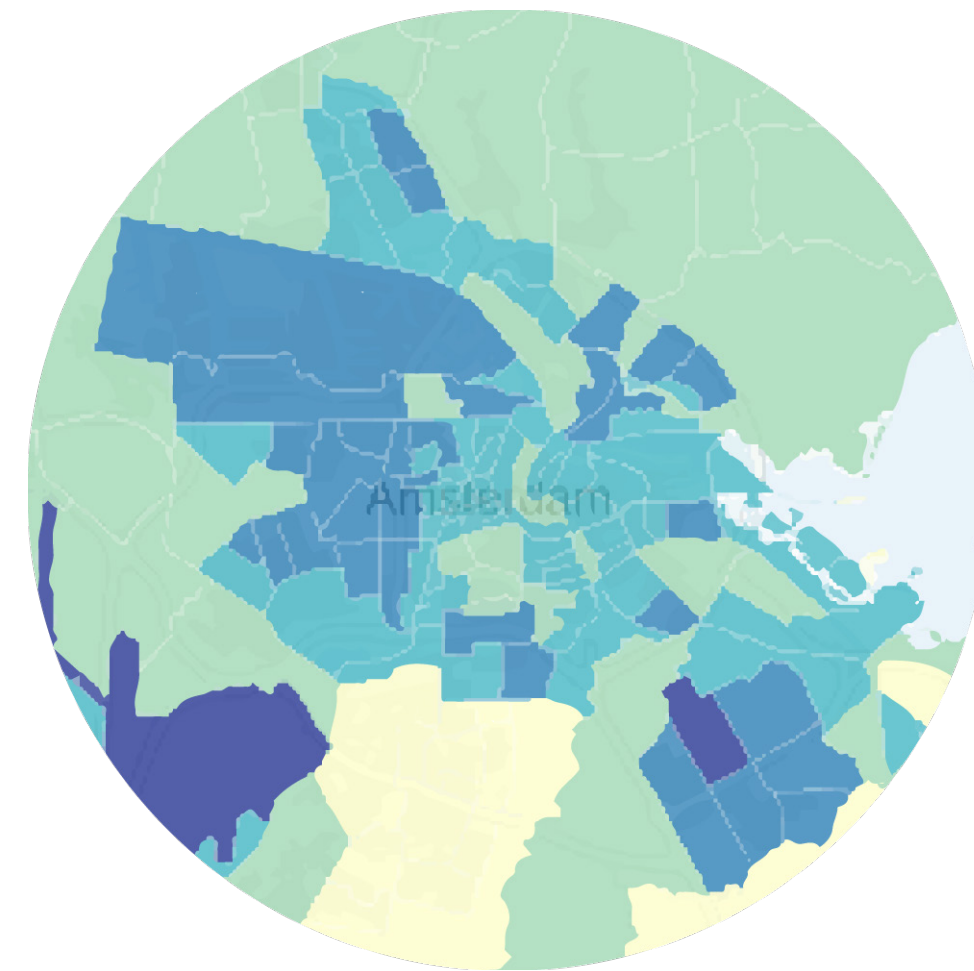

## DEMAND FOR INTERACTION

More contact with neighbors.  
Increased loneliness in big  
cities.

Scale: 0-80%



# SOCIAL

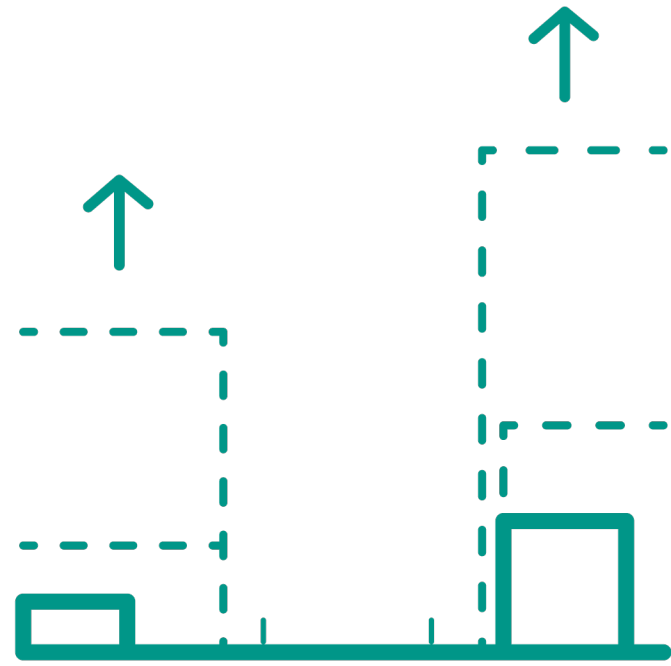

**TRANSFORMING AREA**  
Completely new area.  
Constantly developing area.

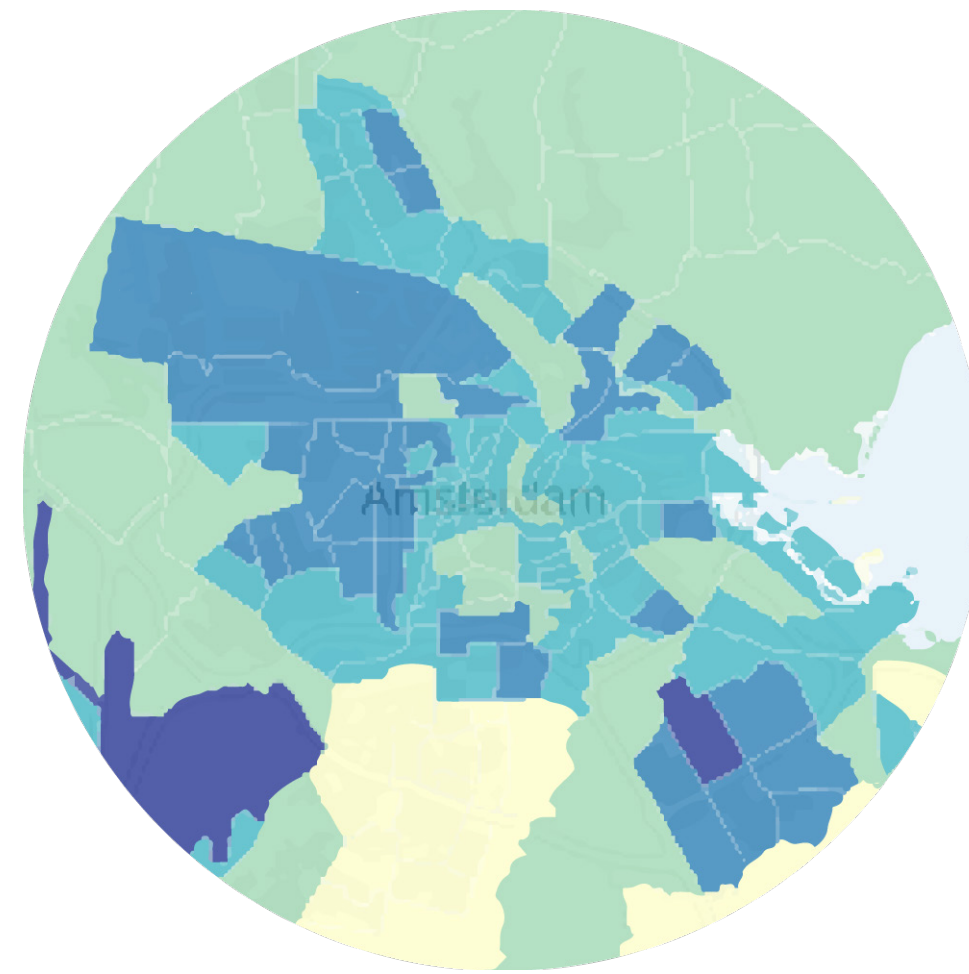

**DEMAND FOR INTERACTION**  
More contact with neighbors.  
Increased loneliness in big  
cities.  
Scale: 0-80%

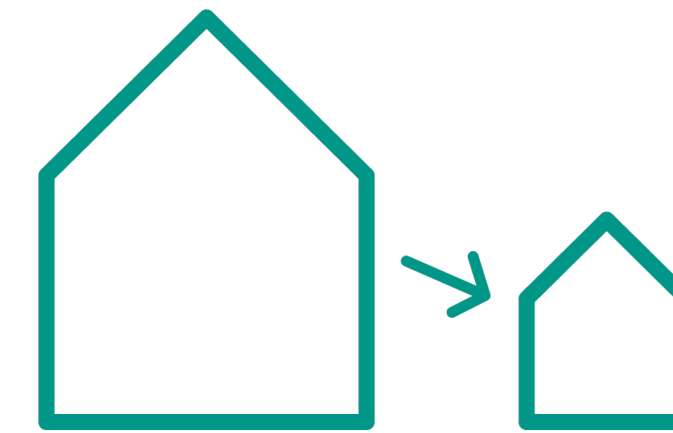

**SMALLER HOUSES.**  
Leave out living room.  
Studio Living.



# PROBLEM STATEMENT



## **NEW IDENTITY**

Transition to Mixed Urban City.  
Increased density  
136 --> 30.000 Inhabitants.

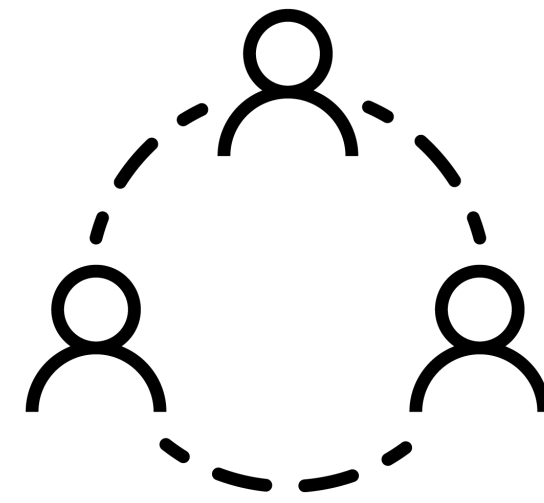

## **SOCIAL CONNECION**

Need for Social interaction.  
Spot to come together  
Knowledge Sharing.

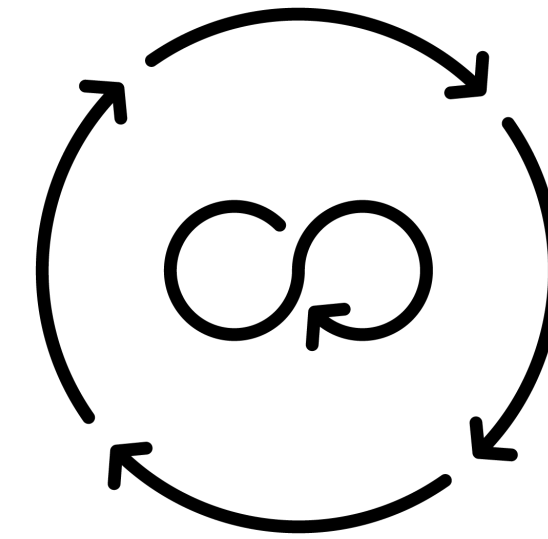

## **CIRCULAR ECONOMY**

Material re-use.  
Design out waste.





**UPCYCLE AMSTEL**

Amstel III  
re-cycle, re-use  
Waste & Up-cycle  
Design for Disassembly.

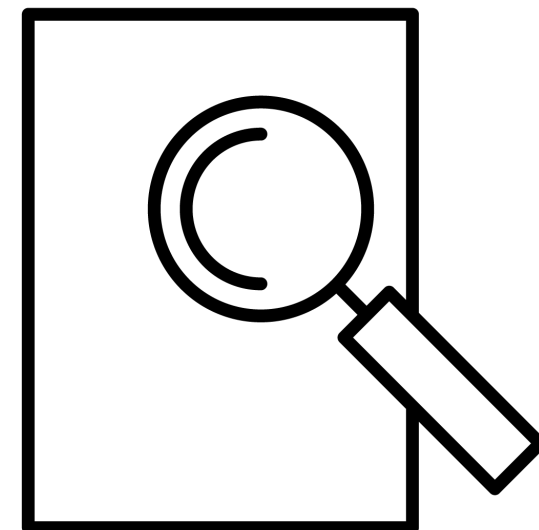

**RESEARCH**

Case Study  
Material Potential

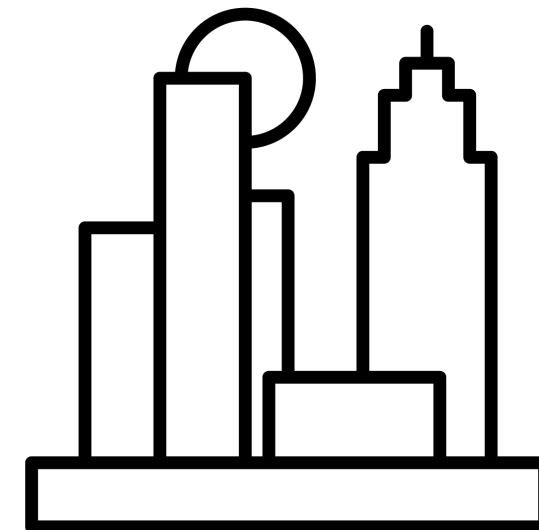

**URBAN PLAN**

Amstel III  
Main street  
Park

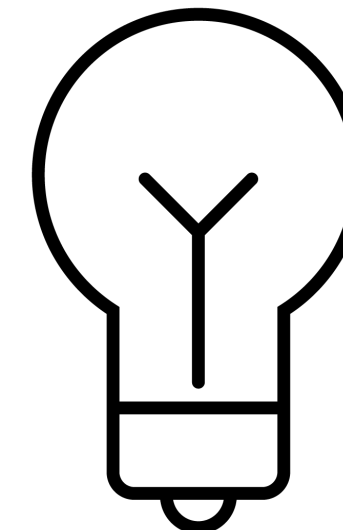

**CONCEPT**

Cultural Meeting spot.  
Circular Demonstrator.  
Innovation hub.

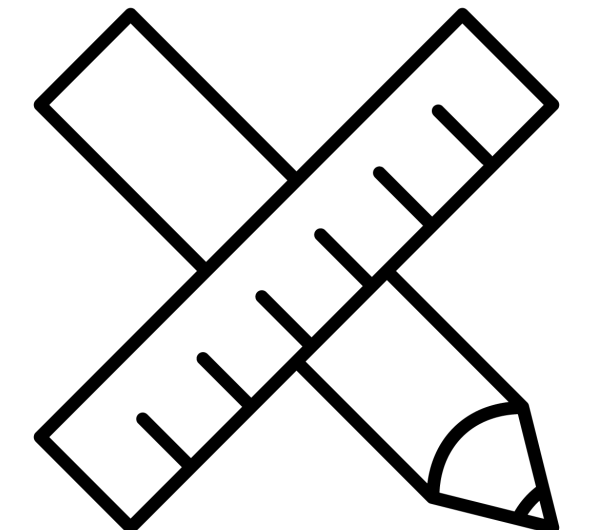

**DESIGN**

Program  
Volume study.





**UPCYCLE AMSTEL**

Amstel III  
re-cycle, re-use  
Waste & Up-cycle  
Design for Disassembly.



**RESEARCH**

Case Study  
Material Potential



**URBAN PLAN**

Amstel III  
Main street  
Park

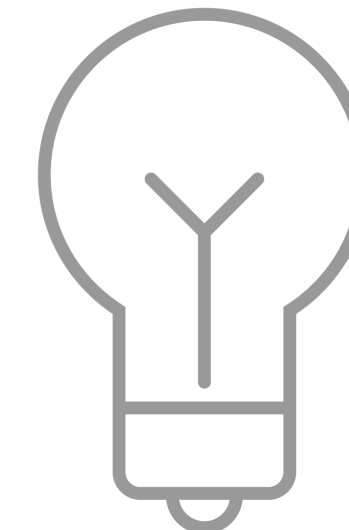

**CONCEPT**

Cultural Meeting spot.  
Circular Demonstrator.  
Innovation hub.

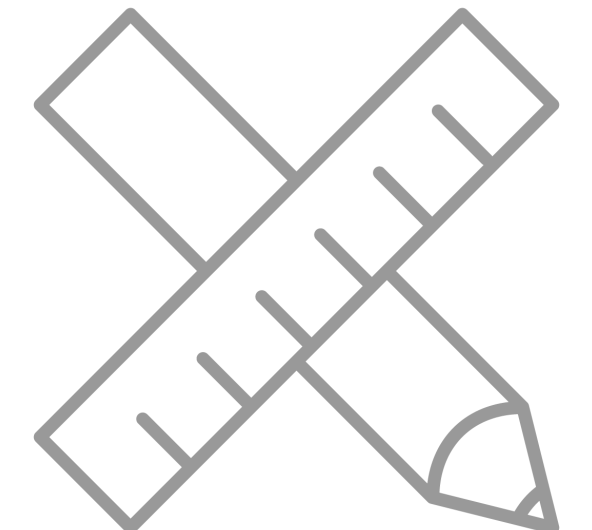

**DESIGN**

Program  
Volume study.



**3XN  
GXN**

**TU Delft**

**×** Gemeente  
**×** Amsterdam

# UP

# CYCLE

# AMSTEL

THIS BOOK CONTAINS TOOLS FOR A CIRCULAR AMSTEL-STAD





## **THE EUROPEAN UNION**

Using a circular economy to economic resilience and global position.



## **THE NETHERLANDS**

A 7.3 bn. potential prompts the Netherlands to be fully circular by 2050.



## **CITY OF AMSTERDAM**

European Capital of Circularity



## Re-use, re-cycle and waste

Towards a new design chain

### **Reuse, recycle, downcycle and waste.**

To get an understanding of the circular economy on material level four terms are needed: re-use, re-cycle, down-cycle and waste. In image 01 this usual process is described. From the raw material, a yarn, a t-shirt is produced. This t-shirt can be re-used among multiple people. At the end of its lifecycle it can either be recycled into a yarn or the material of the t-shirt can be compressed with the addition of an adhesive to turn it into a new chair. This is called downcycling from a material perspective. From this product you will never be able to create a yarn again. This material might however again be re-used to create another shape until it reaches the end of this lifetime. After its lifetime the material downcycling can happen again until it reaches a point that the material has lost all functional properties and it can only be wasted. Here it will be either incinerated to turn it into CO2 and energy or it will be landfilled if the material is too contaminated to be incinerated.

Together re-use, re-cycle, down-cycle and waste often a fifth term is used: "up-cycle." Although this term assumes an increase in material value it is merely a synonym for downcycling as it fits the same description as given above: mixing it with a different material into an inseparable new material that after the mix will never be able to be recycled into the original raw material. This however is an interesting topic as the value of the new material can be discussed. You could argue that turning five 10-euro wasted t-shirts into a 100-euro chair is upcycling as the value of the material has increased significantly. However, it can also be argued that turning those 5 t-shirts into new t-shirts for a few more times has a lot more value is maintained as it will always be possible to return to the original raw material.



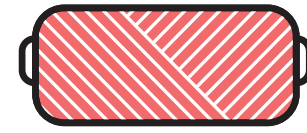

## Re-use, re-cycle and waste

Towards a new design chain

### Reuse, recycle, downcycle and waste.

To get an understanding of the circular economy on material level four terms are needed: re-use, re-cycle, down-cycle and waste. In image 01 this usual process is described. From the raw material, a yarn, a t-shirt is produced. This t-shirt can be re-used among multiple people. At the end of its lifecycle it can either be recycled into a yarn or the material of the t-shirt can be compressed with the addition of an adhesive to turn it into a new chair. This is called downcycling from a material perspective. From this product you will never be able to create a yarn again. This material might however again be re-used to create another shape until it reaches the end of this lifetime. After its lifetime the material downcycling can happen again until it reaches a point that the material has lost all functional properties and it can only be wasted. Here it will be either incinerated to turn it into CO<sub>2</sub> and energy or it will be landfilled if the material is too contaminated to be incinerated.

Together re-use, re-cycle, down-cycle and waste often a fifth term is used: "up-cycle." Although this term assumes an increase in material value it is merely a synonym for downcycling as it fits the same description as given above: mixing it with a different material into an inseparable new material that after the mix will never be able to be recycled into the original raw material. This however is an interesting topic as the value of the new material can be discussed. You could argue that turning five 10-euro wasted t-shirts into a 100-euro chair is upcycling as the value of the material has increased significantly. However, it can also be argued that turning those 5 t-shirts into new t-shirts for a few more times has a lot more value is maintained as it will always be possible to return to the original raw material.



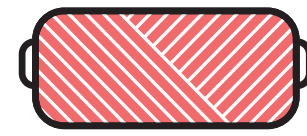

**PRODUCTION**

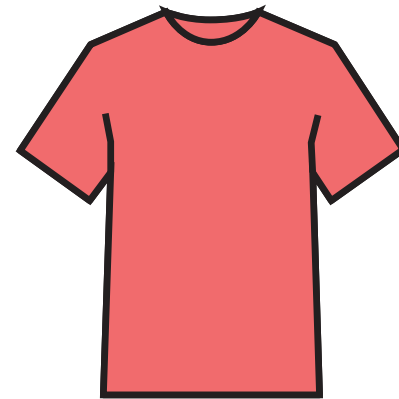

## Re-use, re-cycle and waste

Towards a new design chain

**Reuse, recycle, downcycle and waste.** To get an understanding of the circular economy on material level four terms are needed: re-use, re-cycle, down-cycle and waste. In image 01 this usual process is described. From the raw material, a yarn, a t-shirt is produced. This t-shirt can be re-used among multiple people. At the end of its lifecycle it can either be recycled into a yarn or the material of the t-shirt can be compressed with the addition of an adhesive to turn it into a new chair. This is called downcycling from a material perspective. From this product you will never be able to create a yarn again. This material might however again be re-used to create another shape until it reaches the end of this lifetime. After its lifetime the material downcycling can happen again until it reaches a point that the material has lost all functional properties and it can only be wasted. Here it will be either incinerated to turn it into CO2 and energy or it will be landfilled if the material is too contaminated to be incinerated.

Together re-use, re-cycle, down-cycle and waste often a fifth term is used: "up-cycle." Although this term assumes an increase in material value it is merely a synonym for downcycling as it fits the same description as given above: mixing it with a different material into an inseparable new material that after the mix will never be able to be recycled into the original raw material. This however is an interesting topic as the value of the new material can be discussed. You could argue that turning five 10-euro wasted t-shirts into a 100-euro chair is upcycling as the value of the material has increased significantly. However, it can also be argued that turning those 5 t-shirts into new t-shirts for a few more times has a lot more value is maintained as it will always be possible to return to the original raw material.



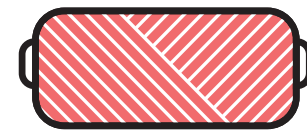

**PRODUCTION**

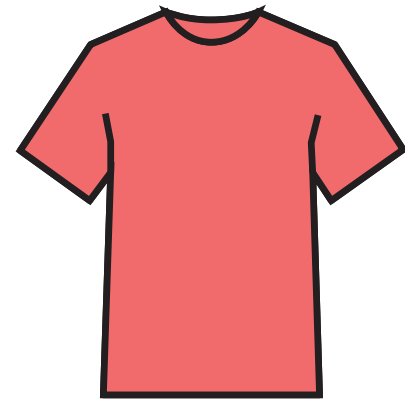

**RE-USE**

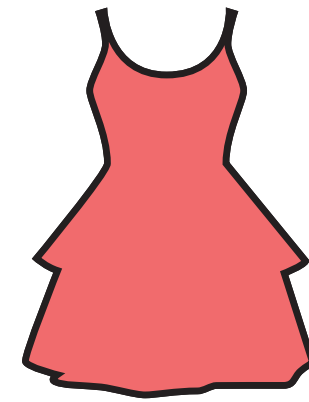

## Re-use, re-cycle and waste

Towards a new design chain

**Reuse, recycle, downcycle and waste.** To get an understanding of the circular economy on material level four terms are needed: re-use, re-cycle, down-cycle and waste. In image 01 this usual process is described. From the raw material, a yarn, a t-shirt is produced. This t-shirt can be re-used among multiple people. At the end of its lifecycle it can either be recycled into a yarn or the material of the t-shirt can be compressed with the addition of an adhesive to turn it into a new chair. This is called downcycling from a material perspective. From this product you will never be able to create a yarn again. This material might however again be re-used to create another shape until it reaches the end of this lifetime. After its lifetime the material downcycling can happen again until it reaches a point that the material has lost all functional properties and it can only be wasted. Here it will be either incinerated to turn it into CO2 and energy or it will be landfilled if the material is too contaminated to be incinerated.

Together re-use, re-cycle, down-cycle and waste often a fifth term is used: "up-cycle." Although this term assumes an increase in material value it is merely a synonym for downcycling as it fits the same description as given above: mixing it with a different material into an inseparable new material that after the mix will never be able to be recycled into the original raw material. This however is an interesting topic as the value of the new material can be discussed. You could argue that turning five 10-euro wasted t-shirts into a 100-euro chair is upcycling as the value of the material has increased significantly. However, it can also be argued that turning those 5 t-shirts into new t-shirts for a few more times has a lot more value is maintained as it will always be possible to return to the original raw material.



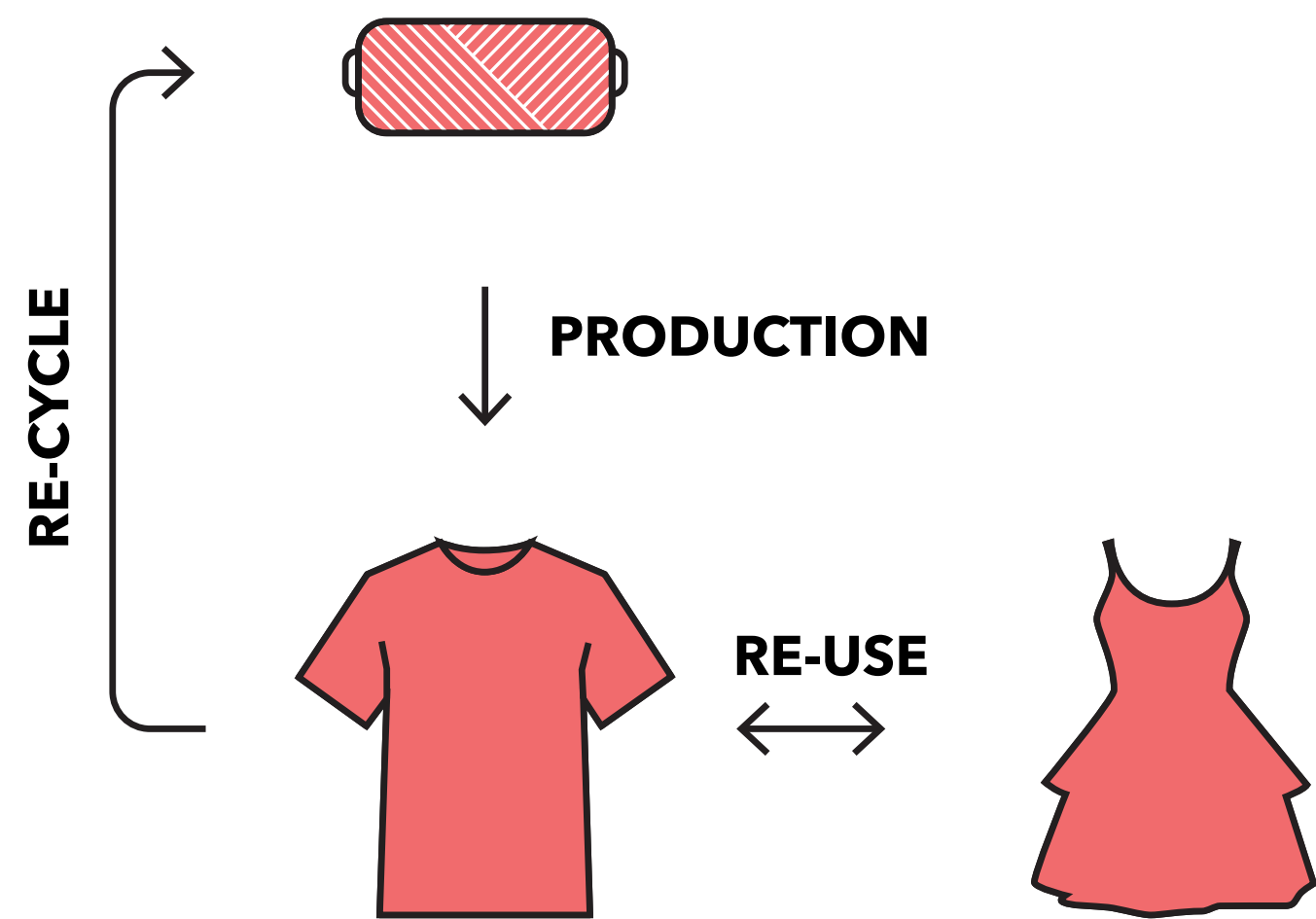

## Re-use, re-cycle and waste

Towards a new design chain

**Reuse, recycle, downcycle and waste.** To get an understanding of the circular economy on material level four terms are needed: re-use, re-cycle, down-cycle and waste. In image 01 this usual process is described. From the raw material, a yarn, a t-shirt is produced. This t-shirt can be re-used among multiple people. At the end of its lifecycle it can either be recycled into a yarn or the material of the t-shirt can be compressed with the addition of an adhesive to turn it into a new chair. This is called downcycling from a material perspective. From this product you will never be able to create a yarn again. This material might however again be re-used to create another shape until it reaches the end of this lifetime. After its lifetime the material downcycling can happen again until it reaches a point that the material has lost all functional properties and it can only be wasted. Here it will be either incinerated to turn it into CO<sub>2</sub> and energy or it will be landfilled if the material is too contaminated to be incinerated.

Together re-use, re-cycle, down-cycle and waste often a fifth term is used: "up-cycle." Although this term assumes an increase in material value it is merely a synonym for downcycling as it fits the same description as given above: mixing it with a different material into an inseparable new material that after the mix will never be able to be recycled into the original raw material. This however is an interesting topic as the value of the new material can be discussed. You could argue that turning five 10-euro wasted t-shirts into a 100-euro chair is upcycling as the value of the material has increased significantly. However, it can also be argued that turning those 5 t-shirts into new t-shirts for a few more times has a lot more value is maintained as it will always be possible to return to the original raw material.



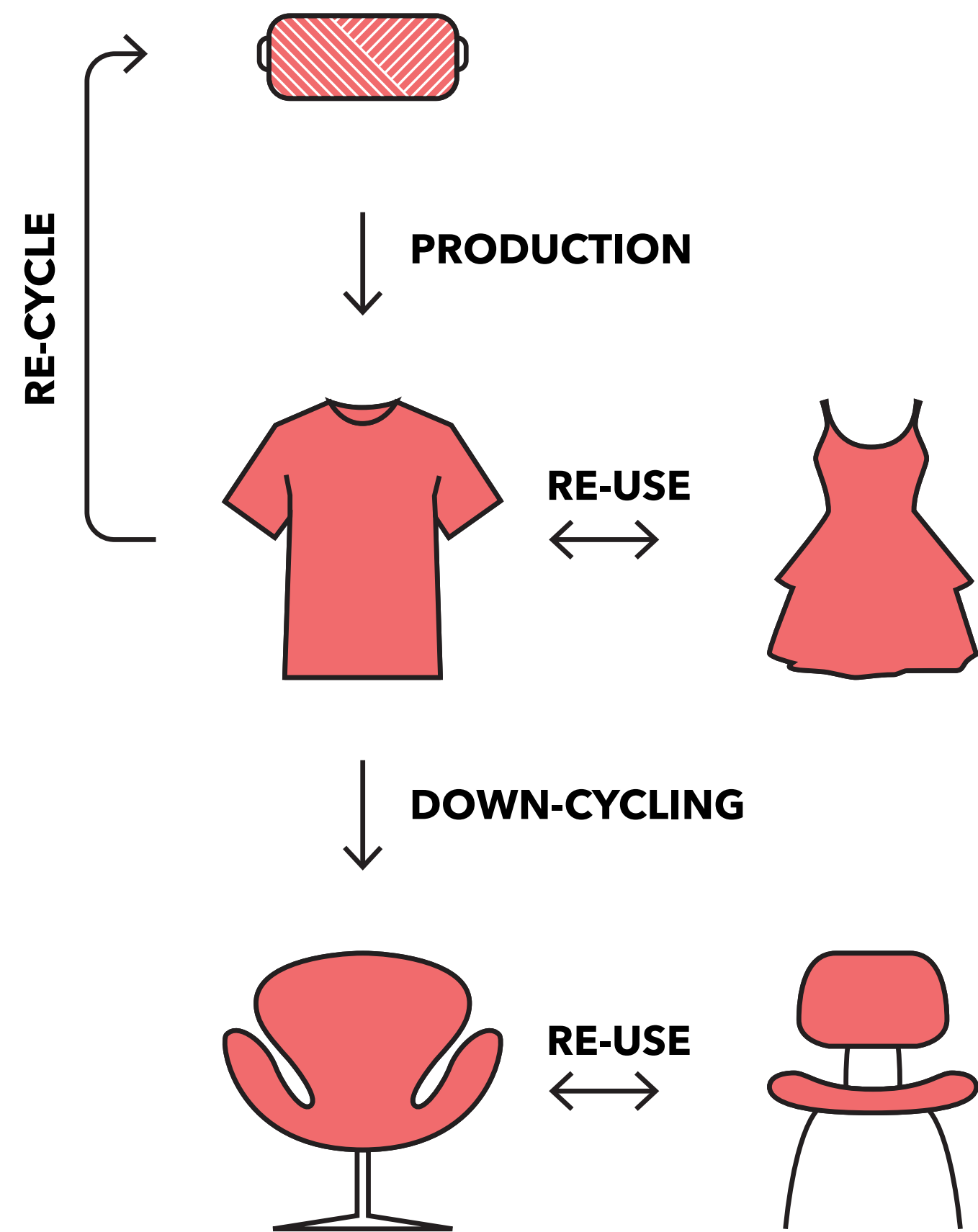

## Re-use, re-cycle and waste

Towards a new design chain

**Reuse, recycle, downcycle and waste.** To get an understanding of the circular economy on material level four terms are needed: re-use, re-cycle, down-cycle and waste. In image 01 this usual process is described. From the raw material, a yarn, a t-shirt is produced. This t-shirt can be re-used among multiple people. At the end of its lifecycle it can either be recycled into a yarn or the material of the t-shirt can be compressed with the addition of an adhesive to turn it into a new chair. This is called downcycling from a material perspective. From this product you will never be able to create a yarn again. This material might however again be re-used to create another shape until it reaches the end of this lifetime. After its lifetime the material downcycling can happen again until it reaches a point that the material has lost all functional properties and it can only be wasted. Here it will be either incinerated to turn it into CO<sub>2</sub> and energy or it will be landfilled if the material is too contaminated to be incinerated.

Together re-use, re-cycle, down-cycle and waste often a fifth term is used: "up-cycle." Although this term assumes an increase in material value it is merely a synonym for downcycling as it fits the same description as given above: mixing it with a different material into an inseparable new material that after the mix will never be able to be recycled into the original raw material. This however is an interesting topic as the value of the new material can be discussed. You could argue that turning five 10-euro wasted t-shirts into a 100-euro chair is upcycling as the value of the material has increased significantly. However, it can also be argued that turning those 5 t-shirts into new t-shirts for a few more times has a lot more value is maintained as it will always be possible to return to the original raw material.



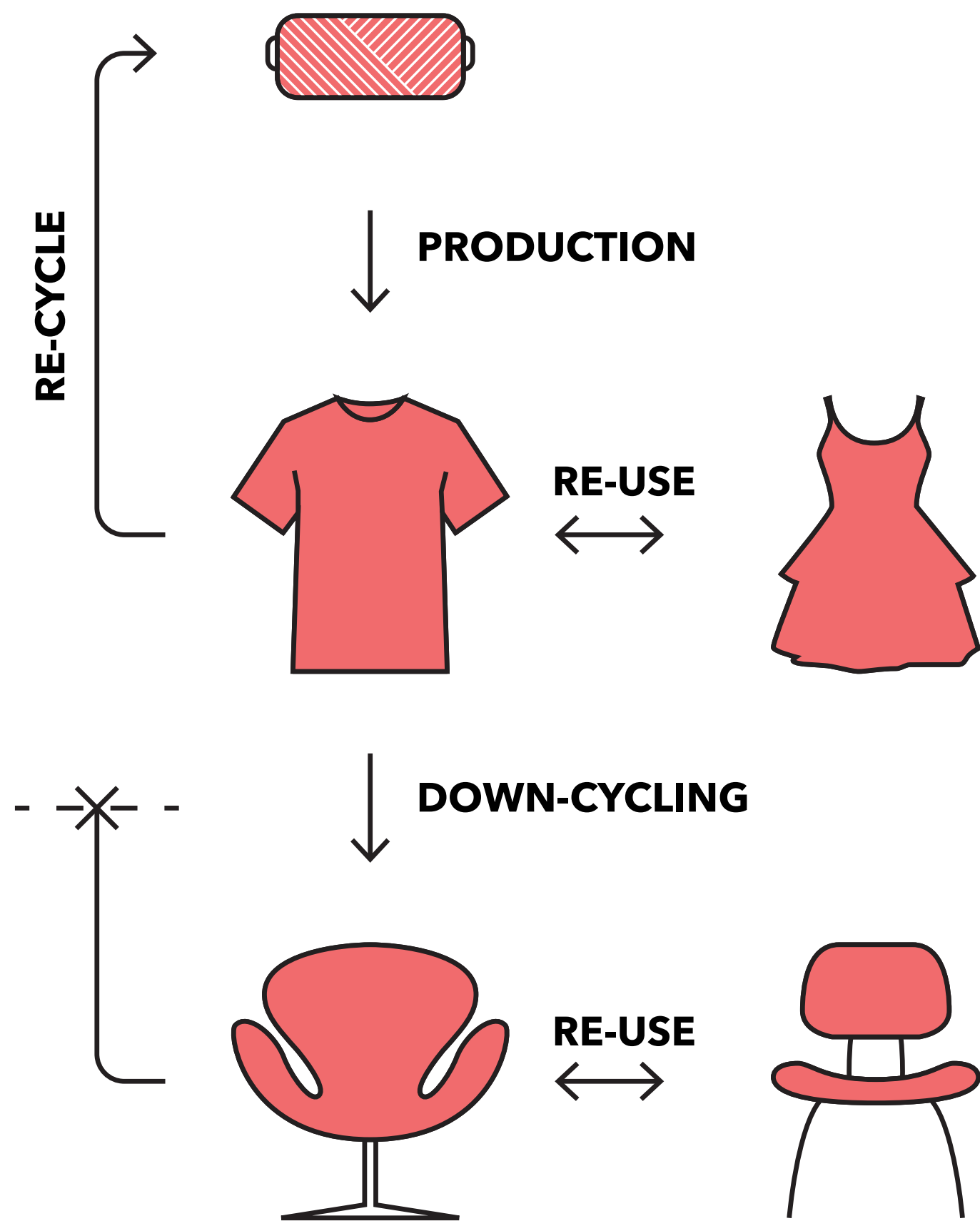

## Re-use, re-cycle and waste

Towards a new design chain

**Reuse, recycle, downcycle and waste.** To get an understanding of the circular economy on material level four terms are needed: re-use, re-cycle, down-cycle and waste. In image 01 this usual process is described. From the raw material, a yarn, a t-shirt is produced. This t-shirt can be re-used among multiple people. At the end of its lifecycle it can either be recycled into a yarn or the material of the t-shirt can be compressed with the addition of an adhesive to turn it into a new chair. This is called downcycling from a material perspective. From this product you will never be able to create a yarn again. This material might however again be re-used to create another shape until it reaches the end of this lifetime. After its lifetime the material downcycling can happen again until it reaches a point that the material has lost all functional properties and it can only be wasted. Here it will be either incinerated to turn it into CO<sub>2</sub> and energy or it will be landfilled if the material is too contaminated to be incinerated.

Together re-use, re-cycle, down-cycle and waste often a fifth term is used: "up-cycle." Although this term assumes an increase in material value it is merely a synonym for downcycling as it fits the same description as given above: mixing it with a different material into an inseparable new material that after the mix will never be able to be recycled into the original raw material. This however is an interesting topic as the value of the new material can be discussed. You could argue that turning five 10-euro wasted t-shirts into a 100-euro chair is upcycling as the value of the material has increased significantly. However, it can also be argued that turning those 5 t-shirts into new t-shirts for a few more times has a lot more value is maintained as it will always be possible to return to the original raw material.



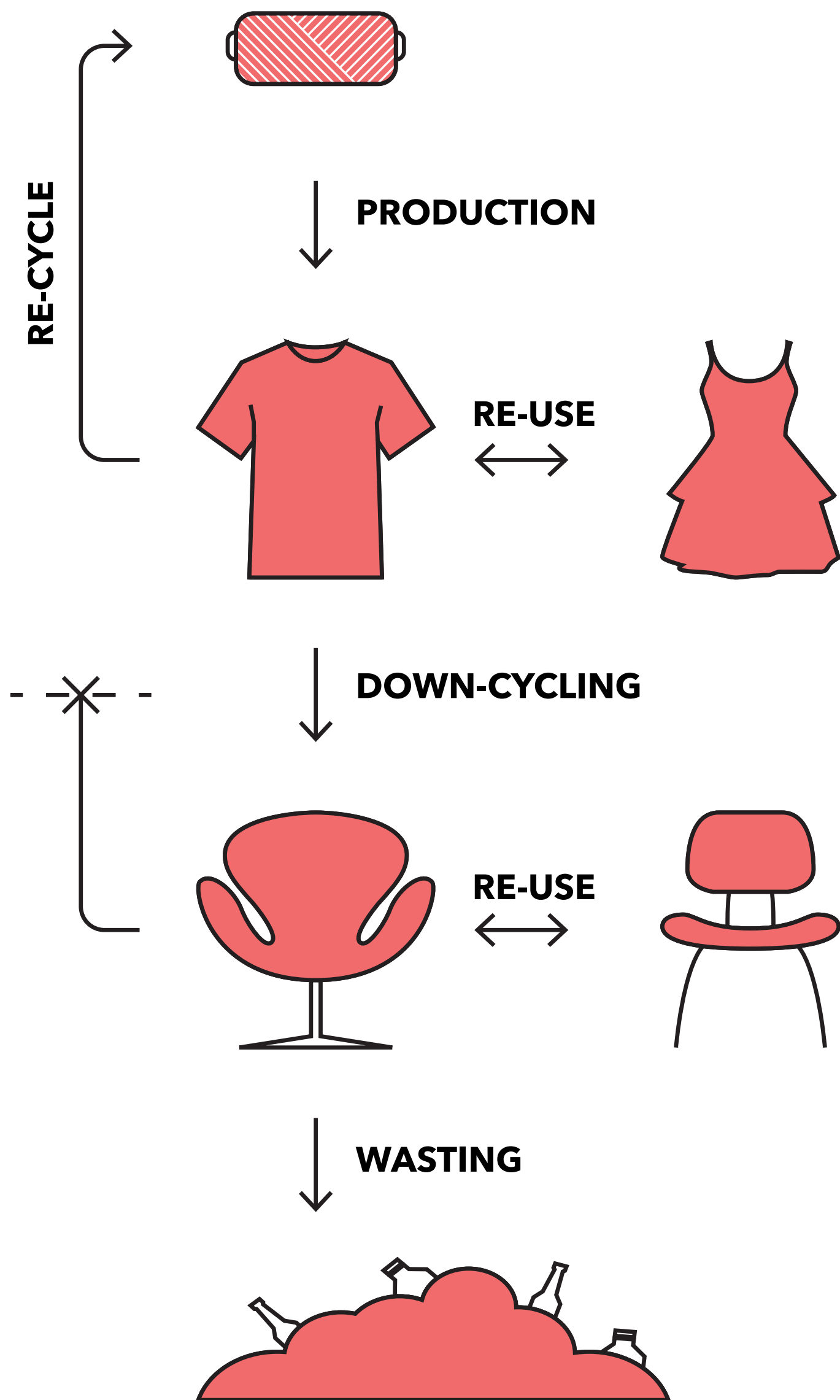

## Re-use, re-cycle and waste

Towards a new design chain

**Reuse, recycle, downcycle and waste.** To get an understanding of the circular economy on material level four terms are needed: re-use, re-cycle, down-cycle and waste. In image 01 this usual process is described. From the raw material, a yarn, a t-shirt is produced. This t-shirt can be re-used among multiple people. At the end of its lifecycle it can either be recycled into a yarn or the material of the t-shirt can be compressed with the addition of an adhesive to turn it into a new chair. This is called downcycling from a material perspective. From this product you will never be able to create a yarn again. This material might however again be re-used to create another shape until it reaches the end of this lifetime. After its lifetime the material downcycling can happen again until it reaches a point that the material has lost all functional properties and it can only be wasted. Here it will be either incinerated to turn it into CO<sub>2</sub> and energy or it will be landfilled if the material is too contaminated to be incinerated.

Together re-use, re-cycle, down-cycle and waste often a fifth term is used: "up-cycle." Although this term assumes an increase in material value it is merely a synonym for downcycling as it fits the same description as given above: mixing it with a different material into an inseparable new material that after the mix will never be able to be recycled into the original raw material. This however is an interesting topic as the value of the new material can be discussed. You could argue that turning five 10-euro wasted t-shirts into a 100-euro chair is upcycling as the value of the material has increased significantly. However, it can also be argued that turning those 5 t-shirts into new t-shirts for a few more times has a lot more value is maintained as it will always be possible to return to the original raw material.





Project Circle House  
Location Copenhagen  
Year 2018  
Owner Lejerbo  
Architects Lendager Group, Vandkunsten, 3XN architects  
Photo Helene Høyer Mikkelsen

## Design for Disassembly

### Case study

Circle House project consists of 60 general housing units in Lisbjerg outside Aarhus, which is expected to be completed in 2020.

In addition to serving as housing, Circle House is a scalable demonstration project that can give the building industry new knowledge about circular construction. Circle House consists of a range of building systems that can be assembled, disassembled and reassembled into other buildings while keeping their economic and aesthetic values intact.

The objective is that 90% of the materials being used for the buildings, can be reused without losing significant value. A wide range of materials can be used in the project, the key is the approach of the principles of design for disassembly and circularity. As it is the system that is crucial, great architectural freedom is achieved for material selection in circular construction. The project will be built in the new residential area 'Lisbjerg Bakke', located in the north of Aarhus, currently undergoing a sustainable development plan. The residential typologies are a mix of 2 and 3 story terraced houses and 5-story tower blocks. The super structure of the 3 different typologies is built from the same 6 concrete elements, optimized for a quick construction, disassembly and reuse.

In order to transform the building industry to a circular building practice the entire value chain of the industry needs to be engaged. The Circle House project involves more than 30 Danish companies across the entire industry. The Circle House project aims to develop, propagate and anchor knowledge about circular construction in the industry. As an example of this the architectural development of the project was made in as a so called 'collaboration studio', a joint team consisting of four companies with sustainability as their foundation, Vandkunsten, Lendager Group and 3XN Architects with the professional facilitation and coordination by GXN Innovation.



## Design for Disassembly

### Case study

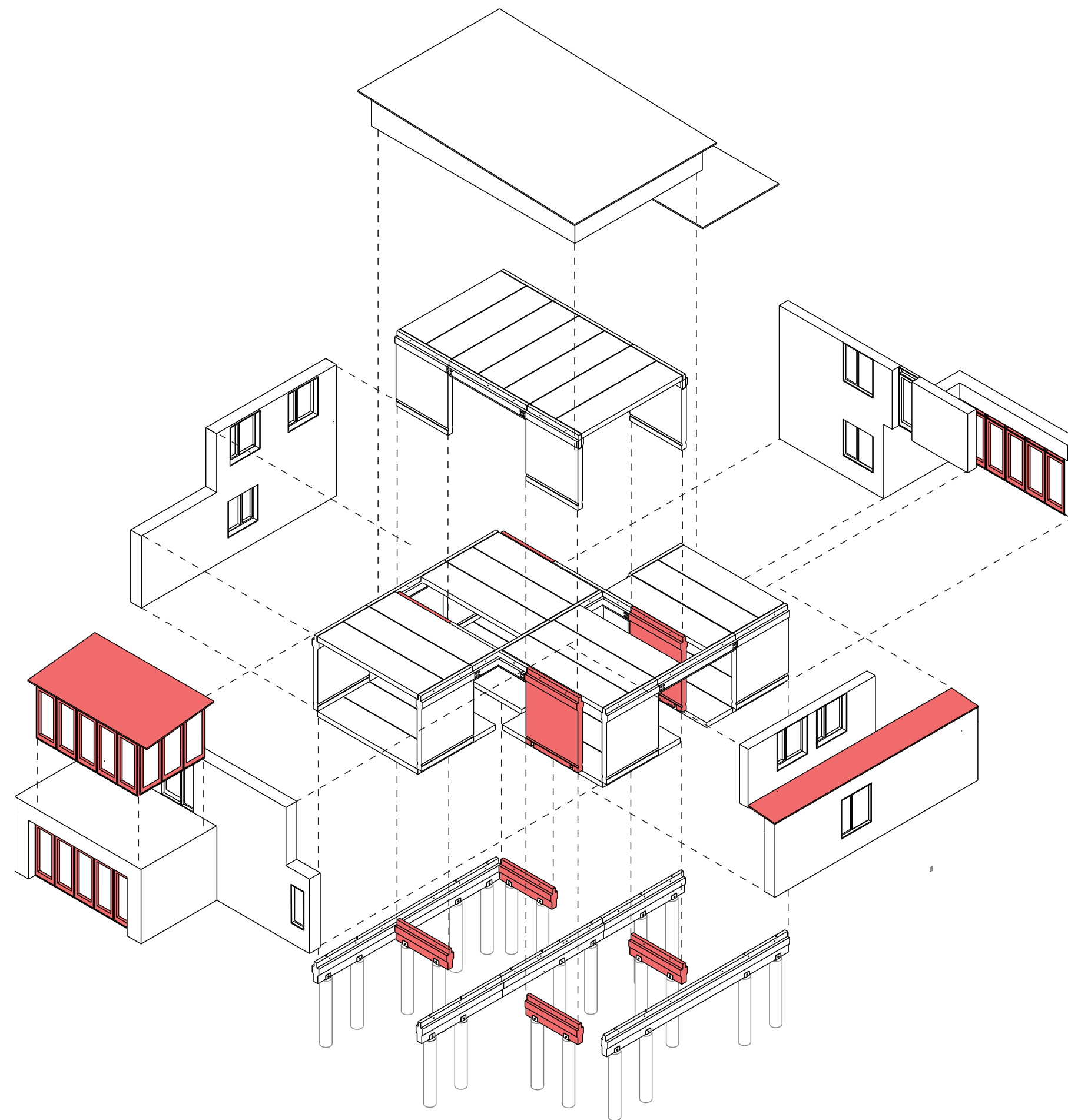

Image 02. The Circle House. (GXN, 2018, p. 110)

Circle House project consists of 60 general housing units in Lisbjerg outside Aarhus, which is expected to be completed in 2020.

In addition to serving as housing, Circle House is a scalable demonstration project that can give the building industry new knowledge about circular construction. Circle House consists of a range of building systems that can be assembled, disassembled and reassembled into other buildings while keeping their economic and aesthetic values intact.

The objective is that 90% of the materials being used for the buildings, can be reused without losing significant value. A wide range of materials can be used in the project, the key is the approach of the principles of design for disassembly and circularity. As it is the system that is crucial, great architectural freedom is achieved for material selection in circular construction. The project will be built in the new residential area 'Lisbjerg Bakke', located in the north of Aarhus, currently undergoing a sustainable development plan. The residential typologies are a mix of 2 and 3 story terraced houses and 5-story tower blocks. The super structure of the 3 different typologies is built from the same 6 concrete elements, optimized for a quick construction, disassembly and reuse.

In order to transform the building industry to a circular building practice the entire value chain of the industry needs to be engaged. The Circle House project involves more than 30 Danish companies across the entire industry. The Circle House project aims to develop, propagate and anchor knowledge about circular construction in the industry. As an example of this the architectural development of the project was made in as a so called 'collaboration studio', a joint team consisting of four companies with sustainability as their foundation, Vandkunsten, Lendager Group and 3XN Architects with the professional facilitation and coordination by GXN Innovation.





Image 03. Cepezed Design

## Design for Disassembly

### Case study

Circle House project consists of 60 general housing units in Lisbjerg outside Aarhus, which is expected to be completed in 2020.

In addition to serving as housing, Circle House is a scalable demonstration project that can give the building industry new knowledge about circular construction. Circle House consists of a range of building systems that can be assembled, disassembled and reassembled into other buildings while keeping their economic and aesthetic values intact.

The objective is that 90% of the materials being used for the buildings, can be reused without losing significant value. A wide range of materials can be used in the project, the key is the approach of the principles of design for disassembly and circularity. As it is the system that is crucial, great architectural freedom is achieved for material selection in circular construction. The project will be built in the new residential area 'Lisbjerg Bakke', located in the north of Aarhus, currently undergoing a sustainable development plan. The residential typologies are a mix of 2 and 3 story terraced houses and 5-story tower blocks. The super structure of the 3 different typologies is built from the same 6 concrete elements, optimized for a quick construction, disassembly and reuse.

In order to transform the building industry to a circular building practice the entire value chain of the industry needs to be engaged. The Circle House project involves more than 30 Danish companies across the entire industry. The Circle House project aims to develop, propagate and anchor knowledge about circular construction in the industry. As an example of this the architectural development of the project was made in as a so called 'collaboration studio', a joint team consisting of four companies with sustainability as their foundation, Vandkunsten, Lendager Group and 3XN Architects with the professional facilitation and coordination by GXN Innovation.





**Hullenbergweg 1-3**  
Mapping materials, quantities, and qualities

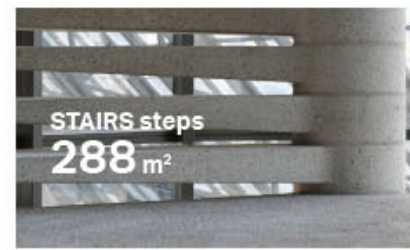

Case building

**MATERIAL POTENTIAL**  
Valuable materials in the building

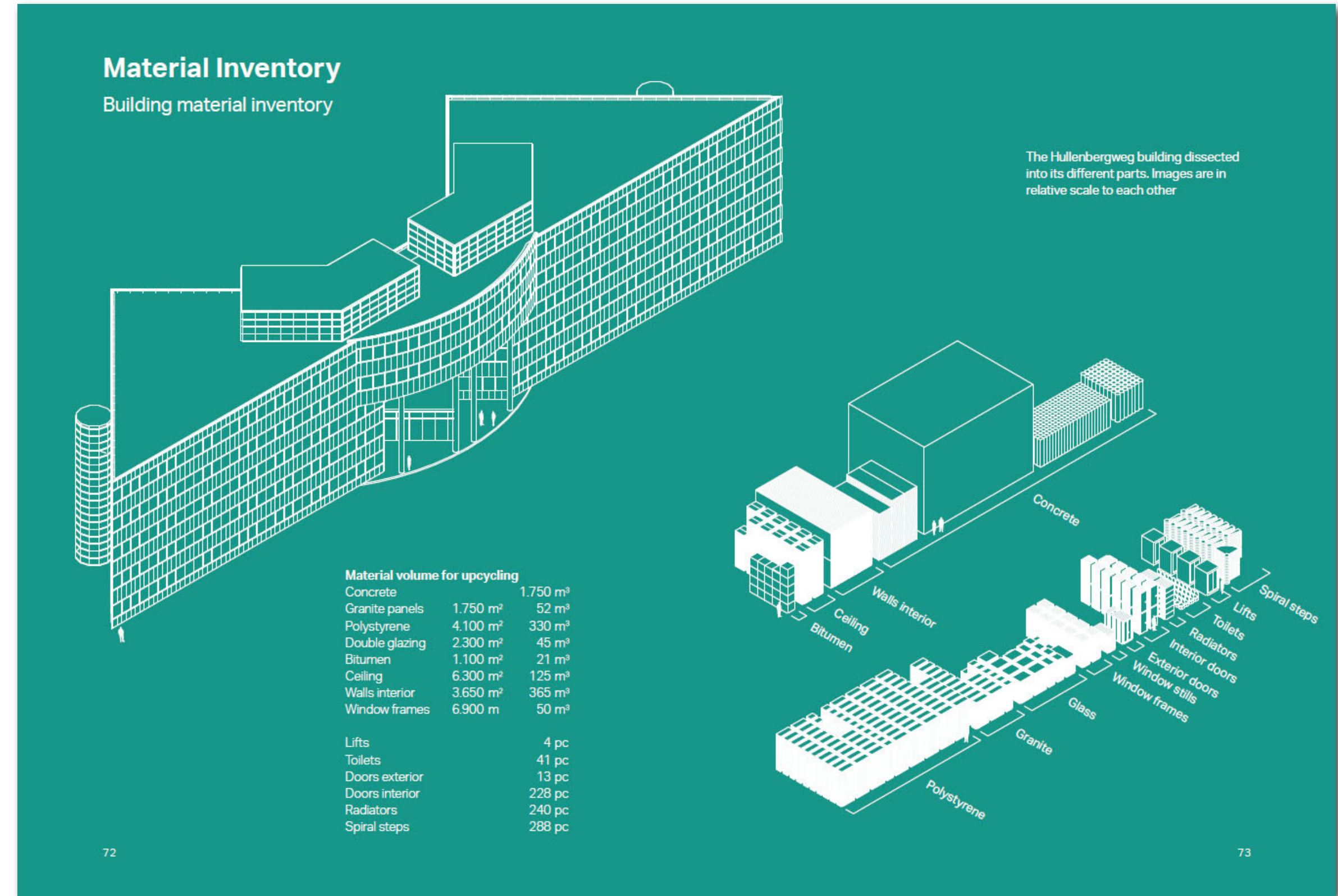

**MATERIAL AMOUNTS**  
Worthless material banks



# Materials and connections

Design for Disassembly

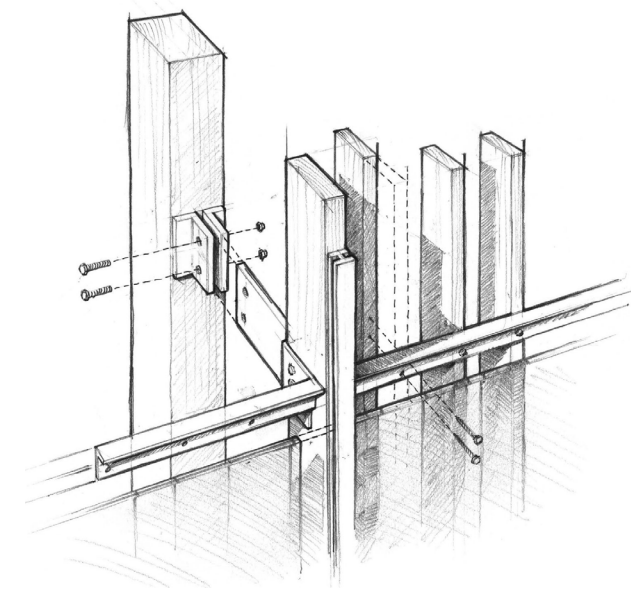
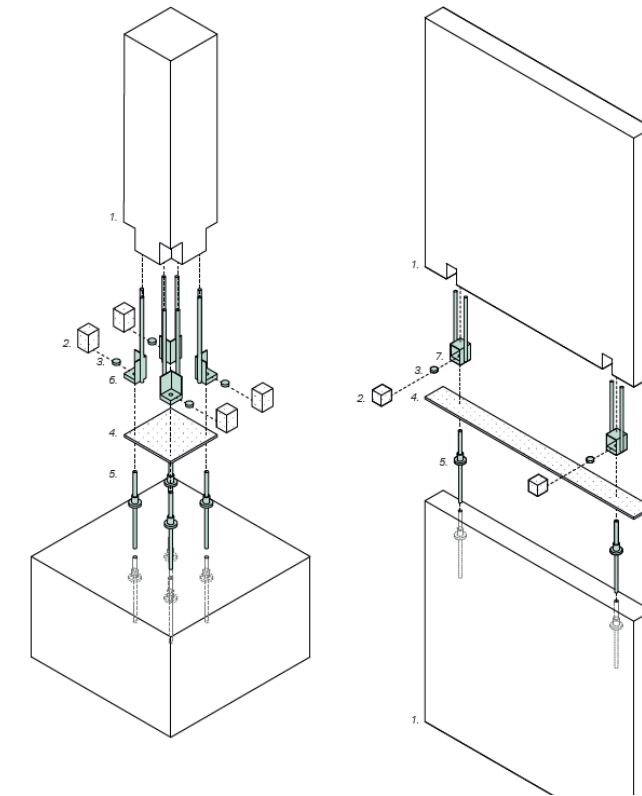
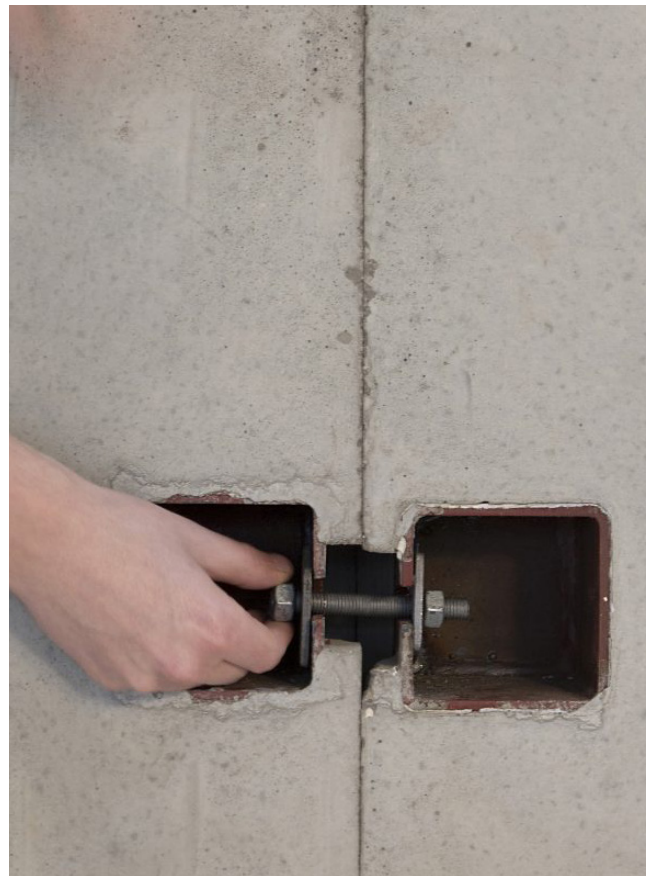



# INTRODUCTION : CONCLUSIONS

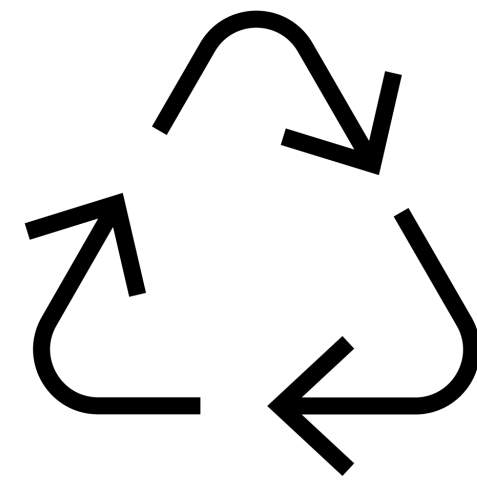

## RE-USE AND RECYCLE

Re-use  
Re-cycle  
Up-cycle.

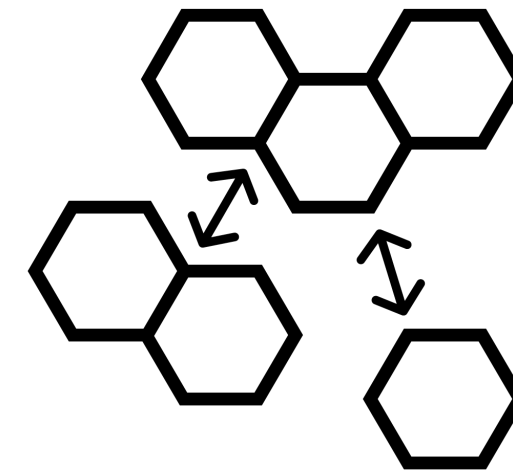

## DESIGN FOR DISASSEMBLY

Main Driver





**UPCYCLE AMSTEL**

Amstel III  
re-cycle, re-use  
Waste & Up-cycle  
Design for Disassembly.

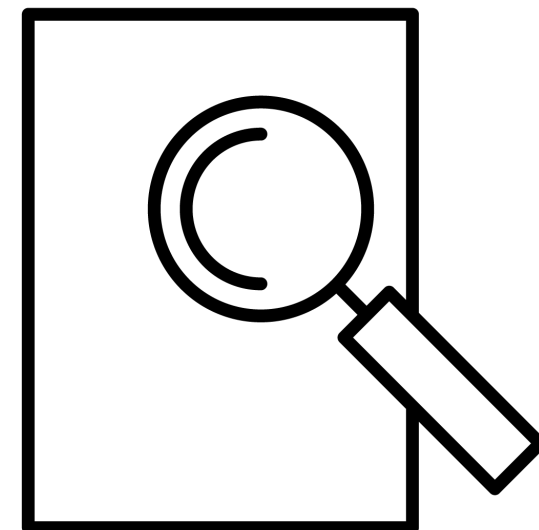

**RESEARCH**

Case Study  
Material Potential



**URBAN PLAN**

Amstel III  
Main street  
Park

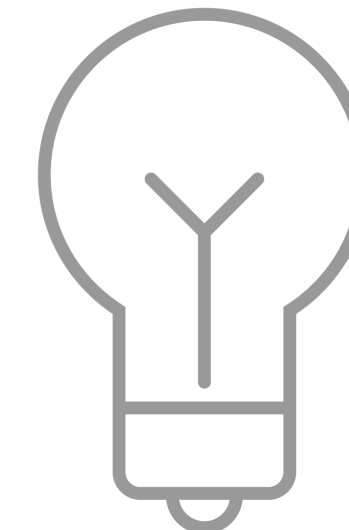

**CONCEPT**

Cultural Meeting spot.  
Circular Demonstrator.  
Innovation hub.

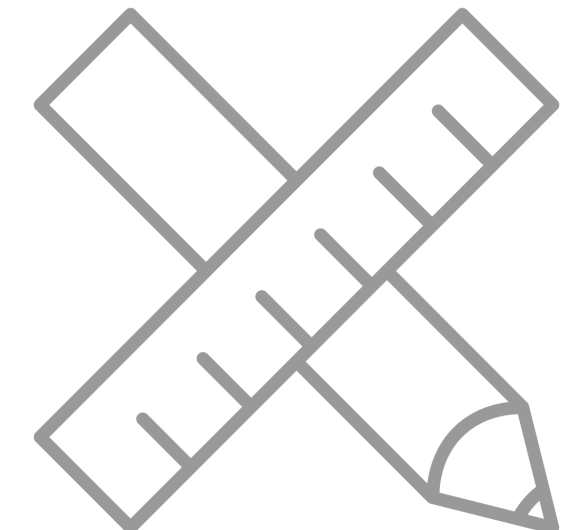

**DESIGN**

Program  
Volume study.











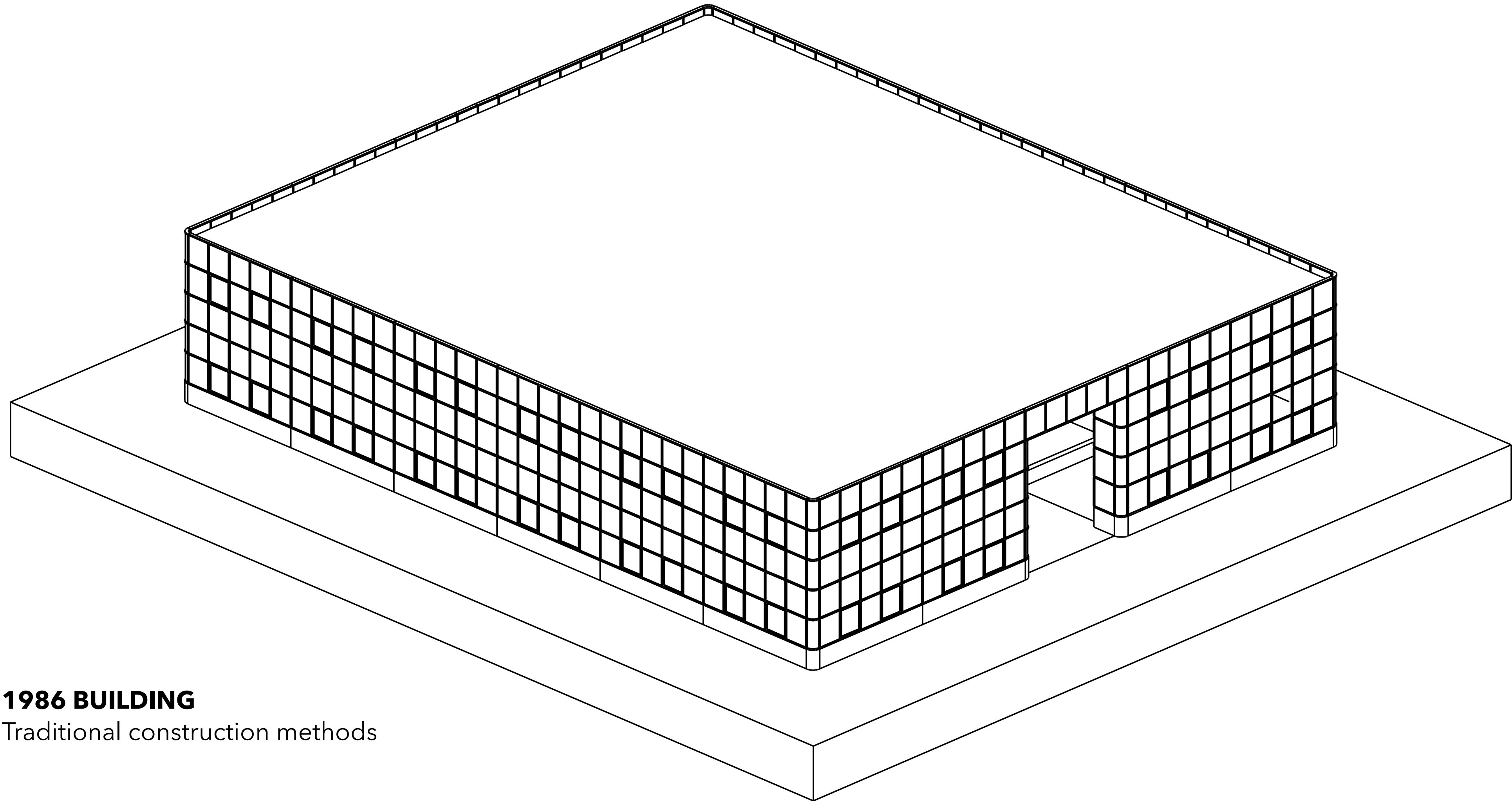

**1986 BUILDING**

Traditional construction methods



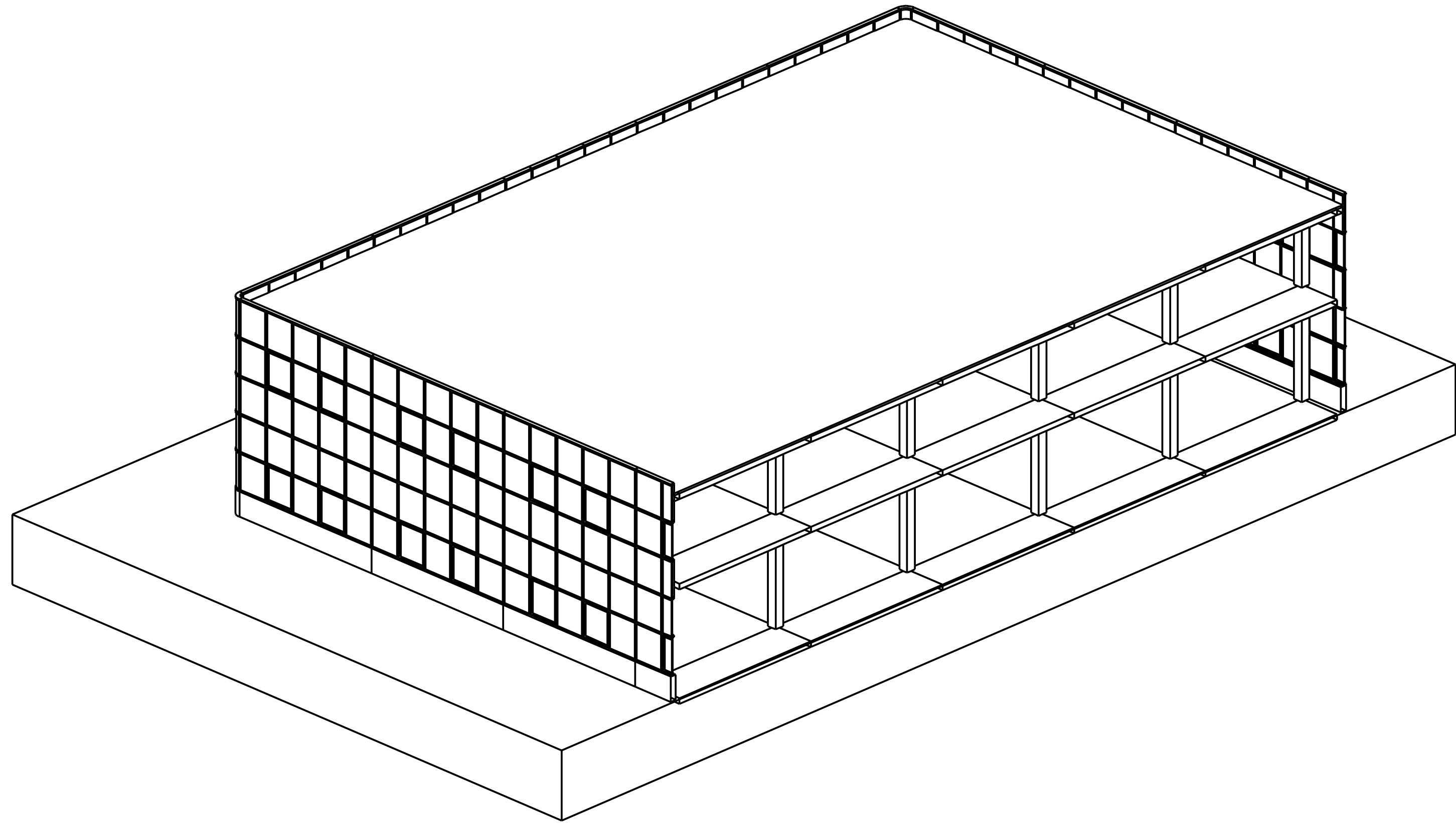

**1986 BUILDING**

Traditional construction methods



$p = 7700$

$p = 7300$

$p = 4080$

$p = 0$

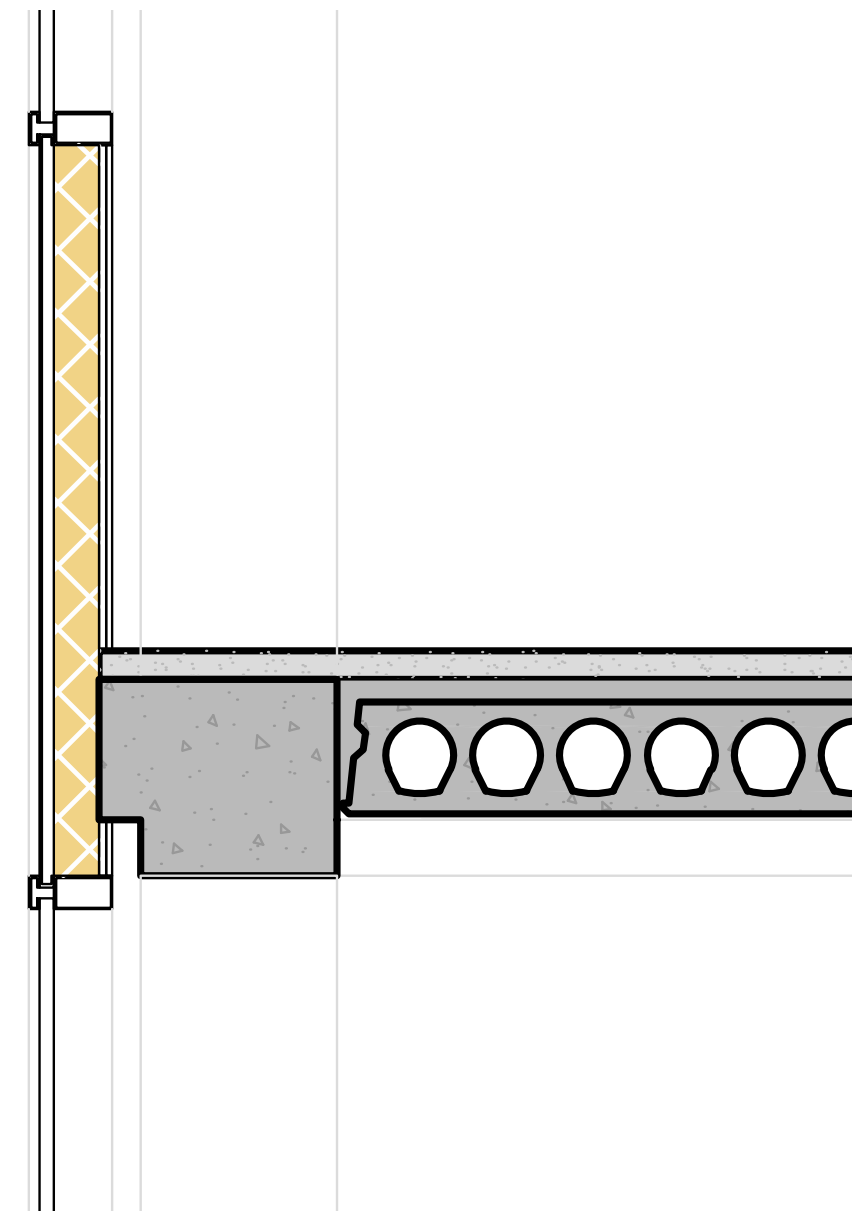
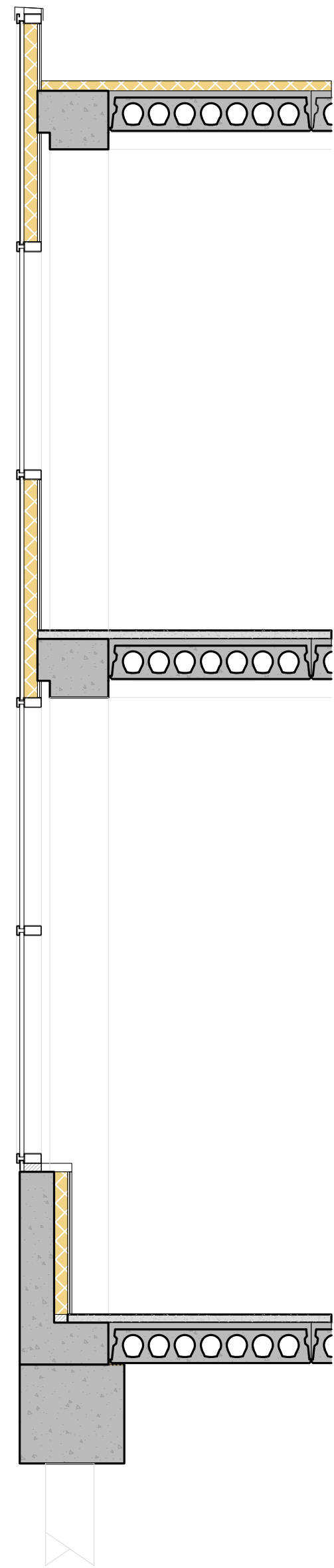

**ORIGINAL BUILDING**

Built in 1986



p = 7700

p = 7300

p = 4080

p = 0

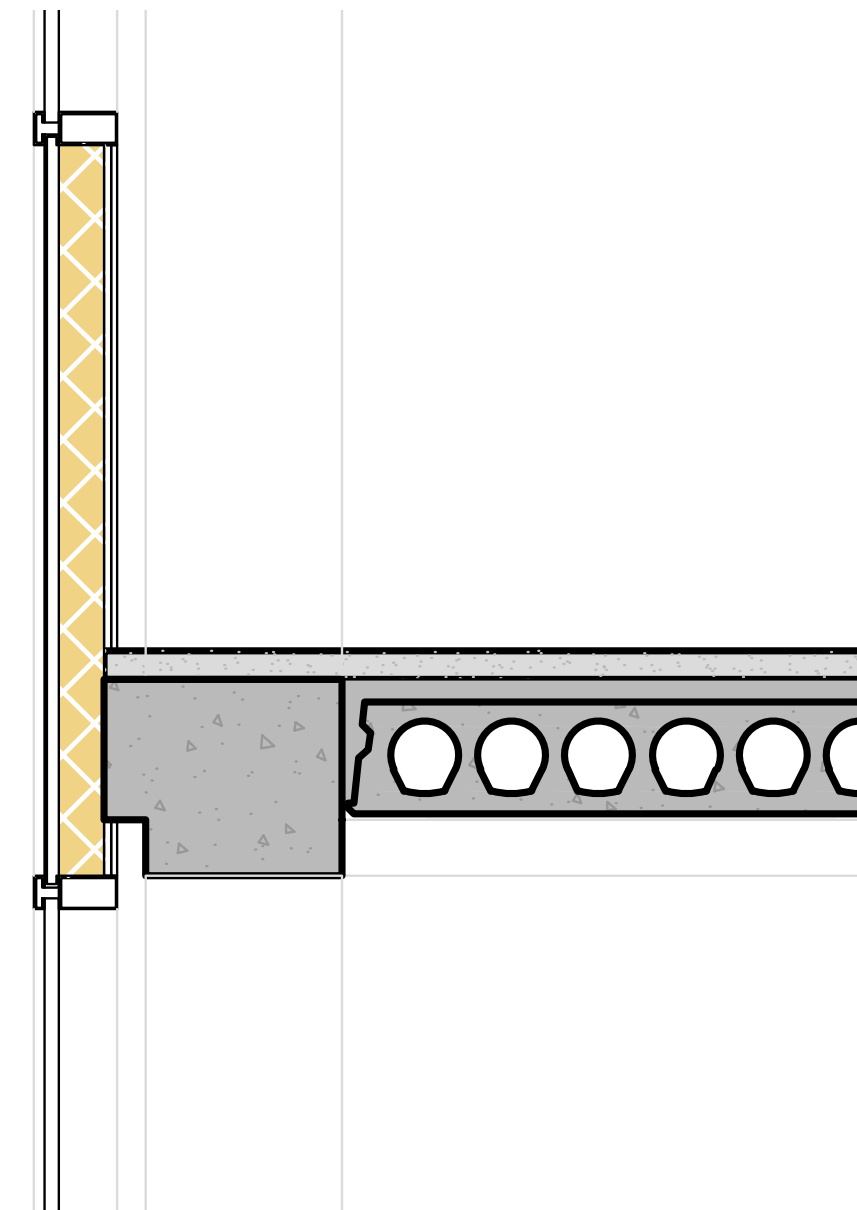
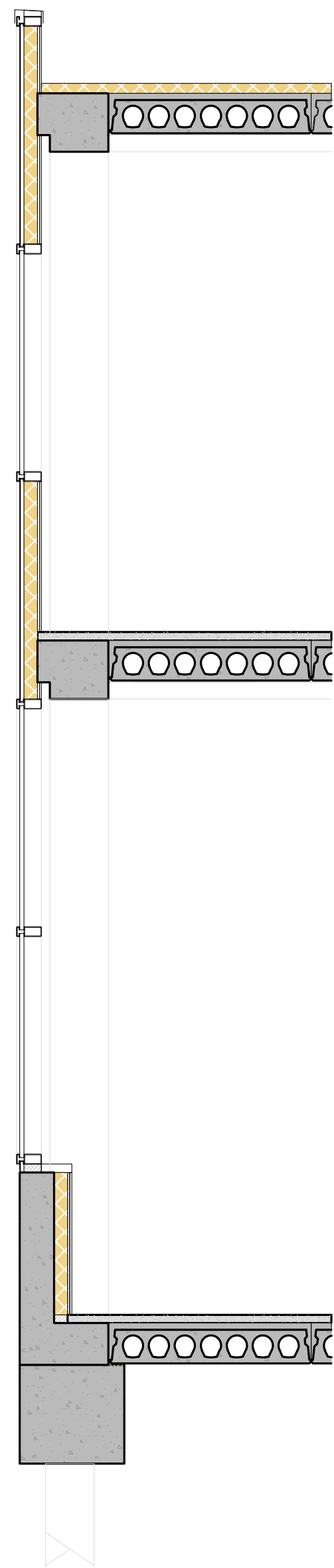

### ORIGINAL BUILDING

Built in 1986

p = 7700

p = 7300

p = 4080

p = 0

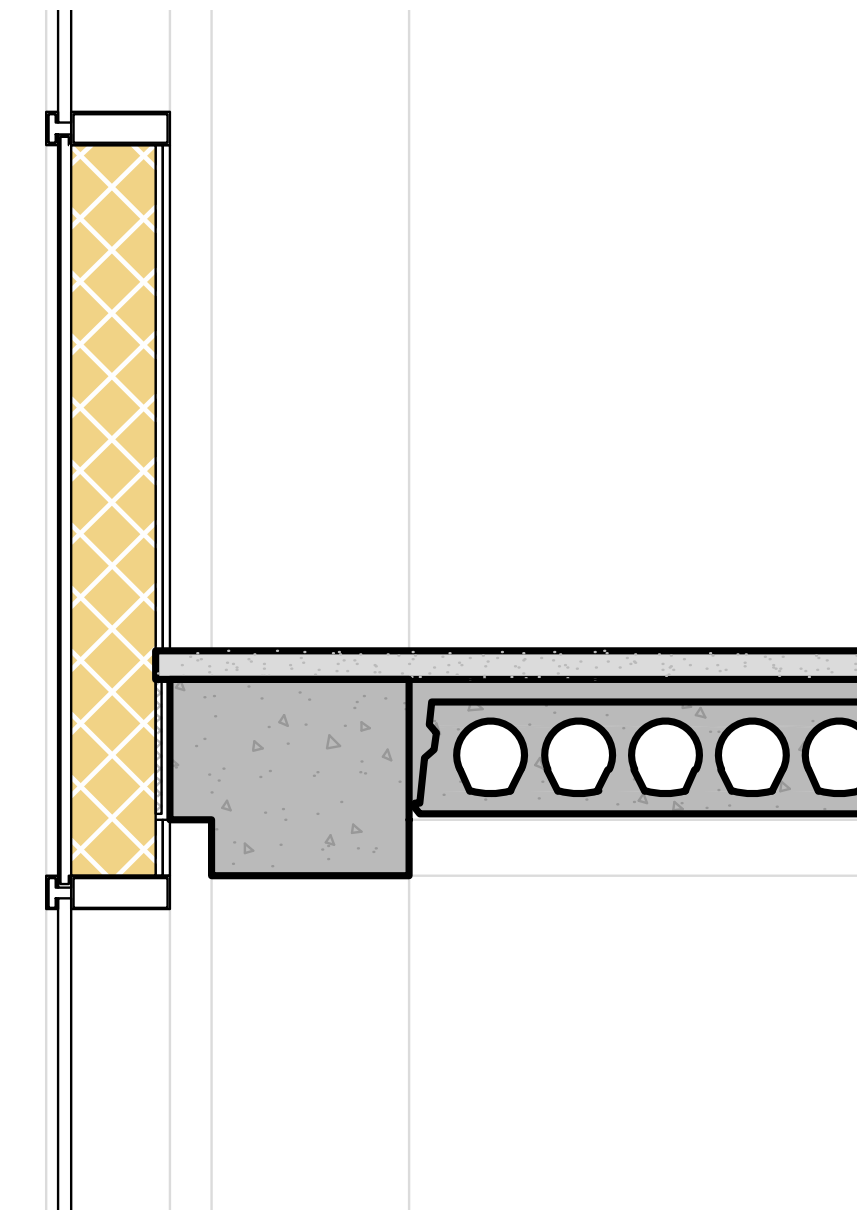
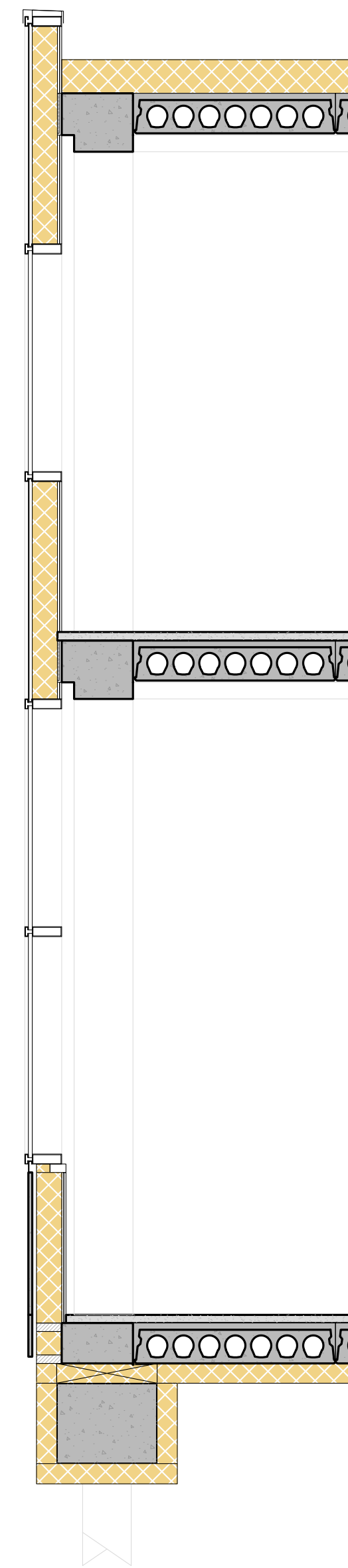

### RENOVATED BUILDING

Concept 2018



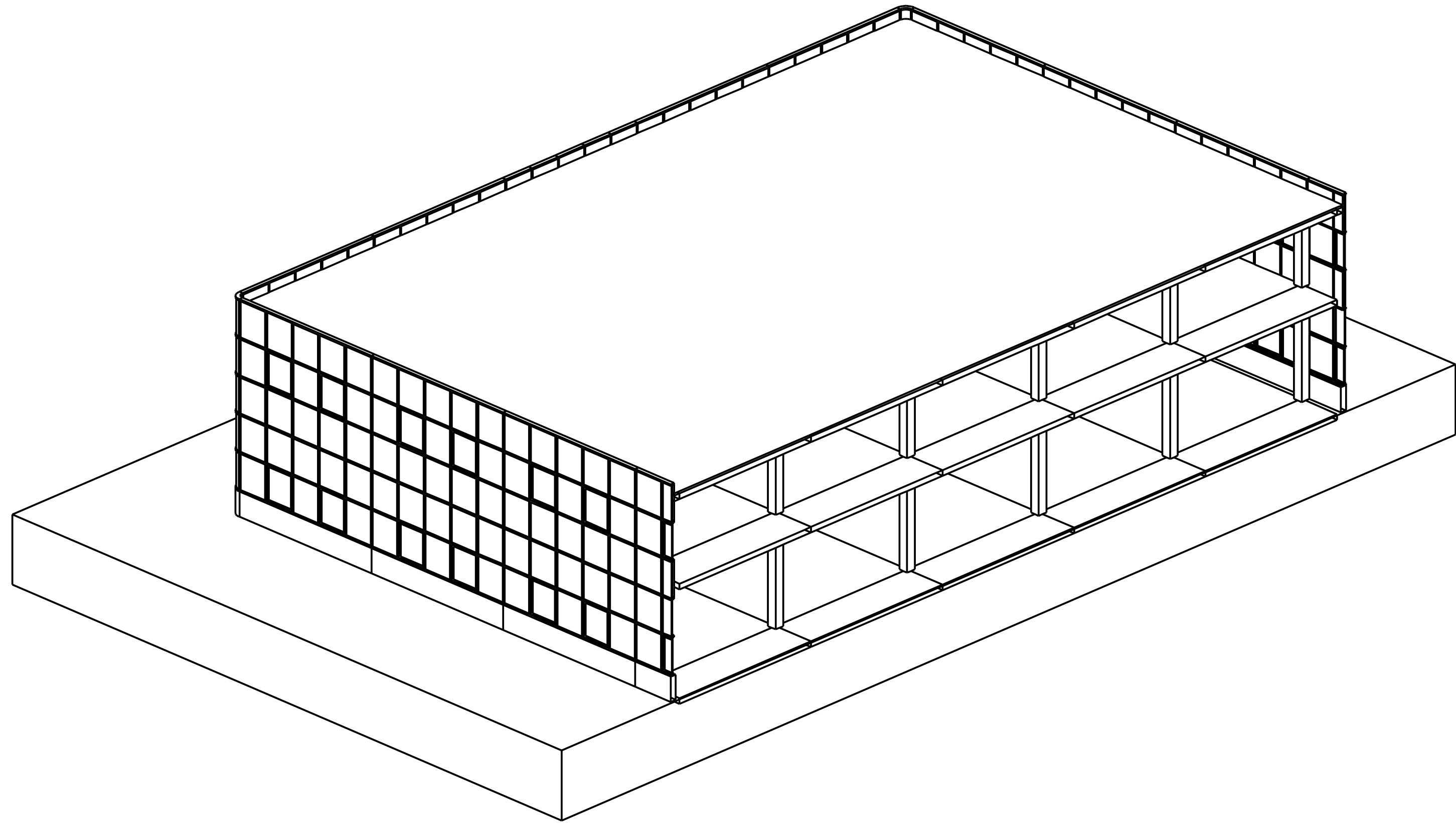

**1986 BUILDING**

Traditional construction methods



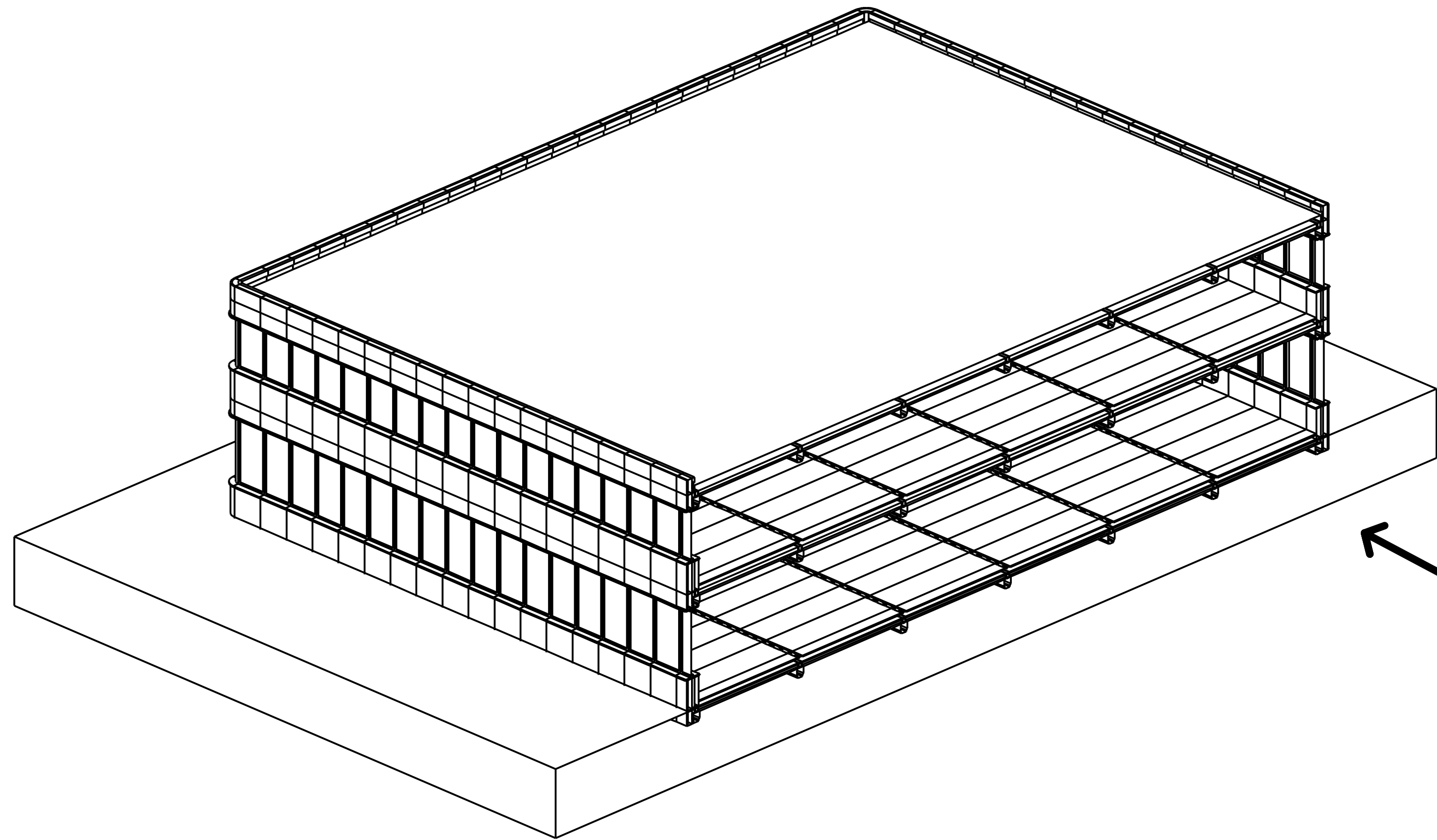

**CIRCLE BUILDING**

Circular construction methods that allow for Disassembly.

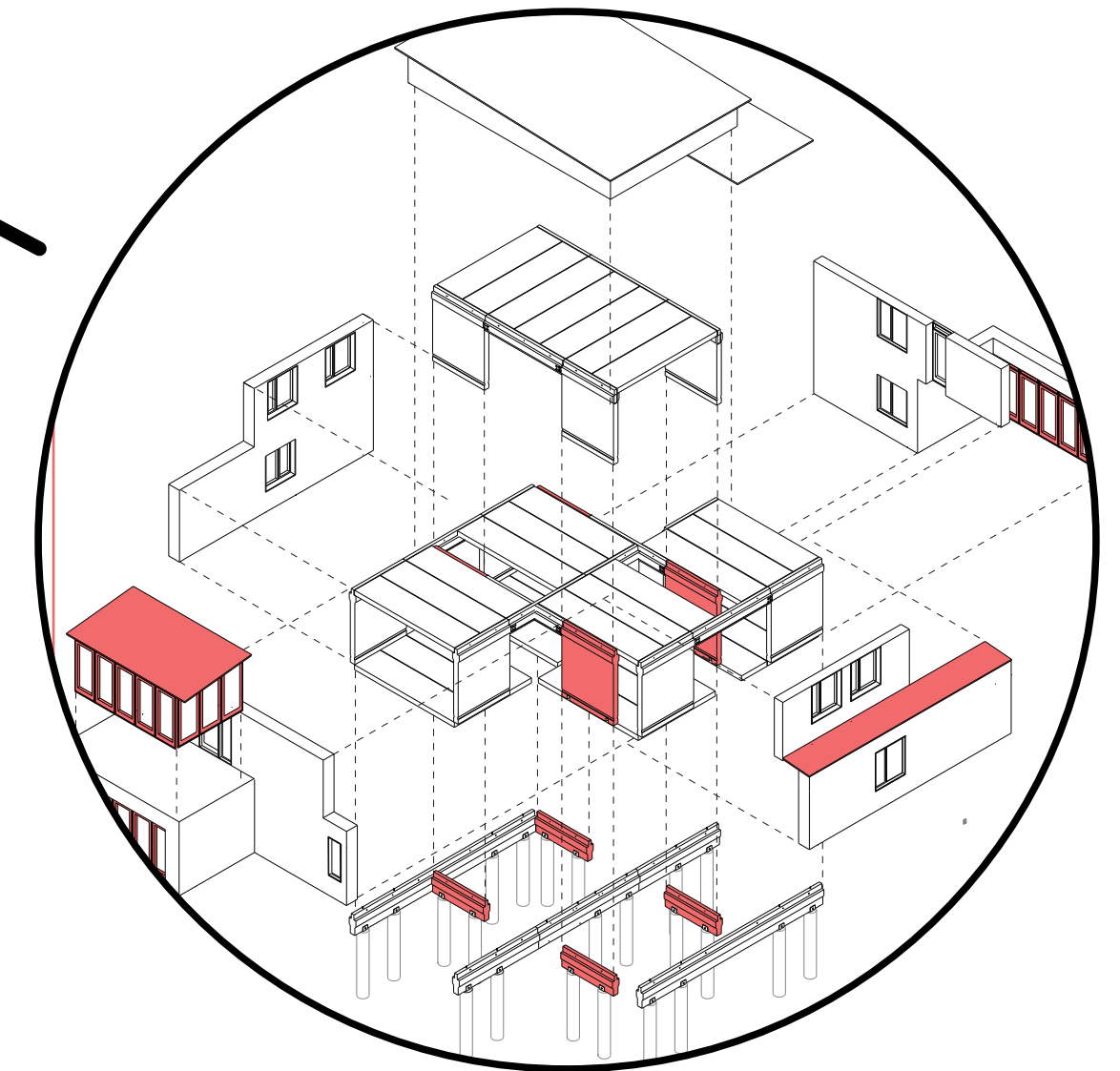
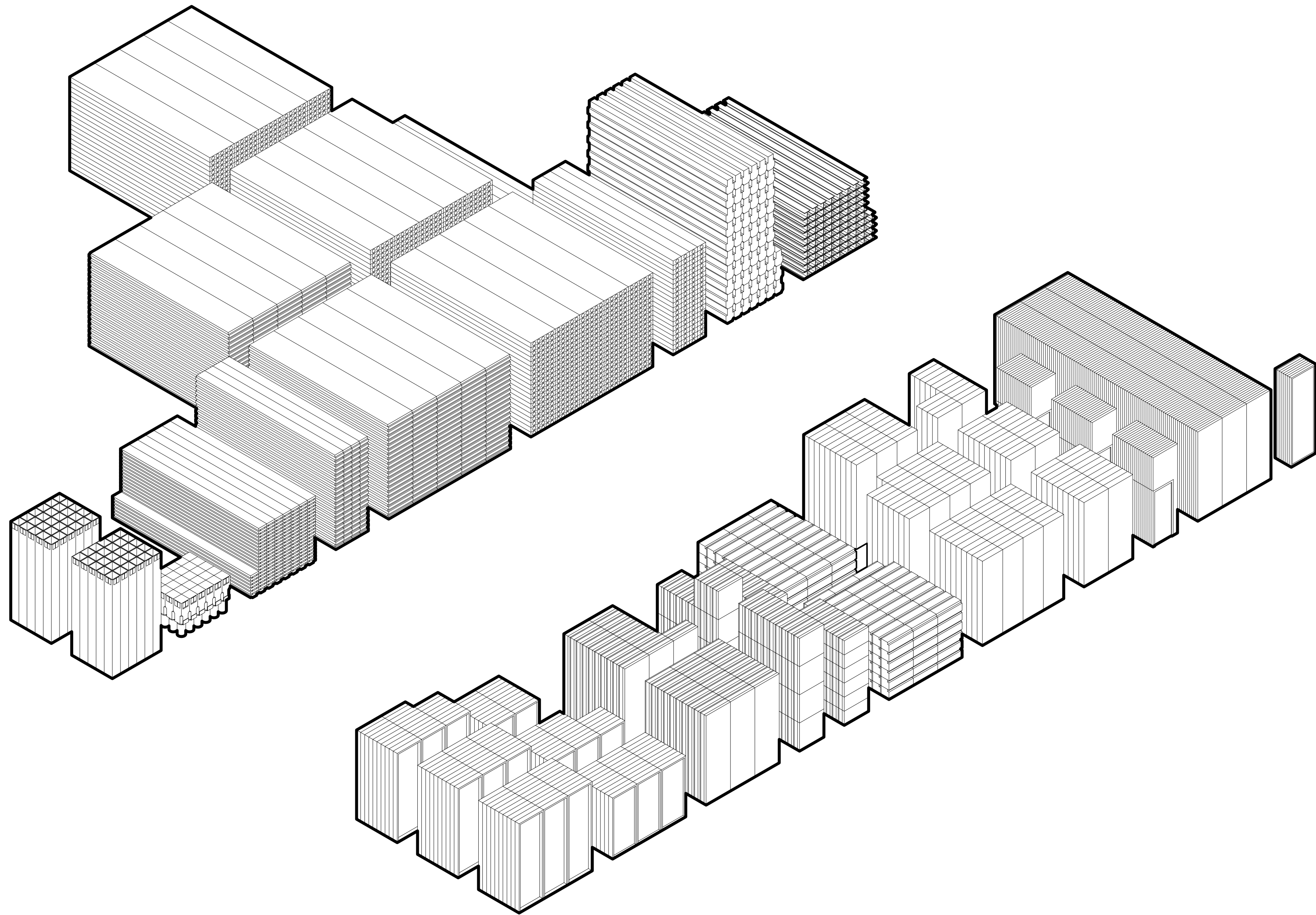

Image 02. The Circle House. (GXN, 2018, p. 110)







$p = 7700$

$p = 7300$

$p = 4080$

$p = 0$

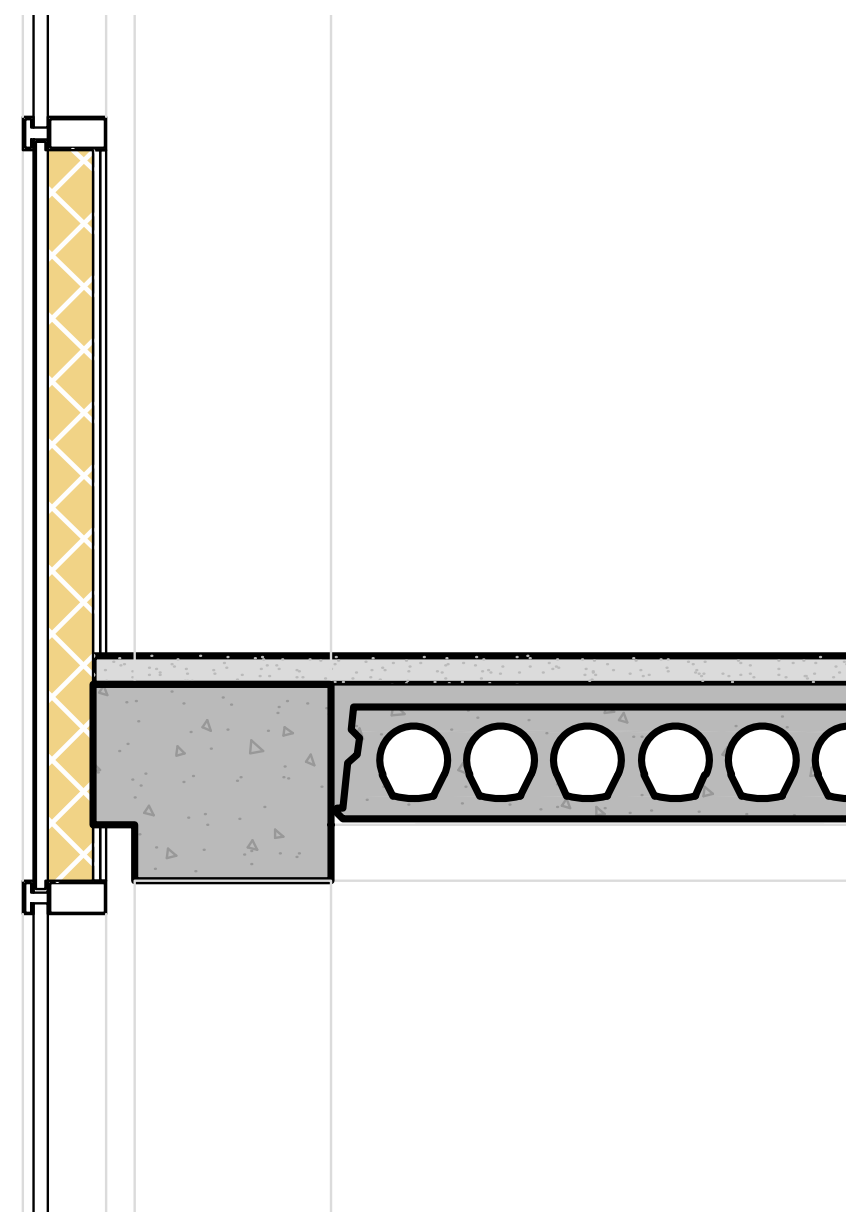
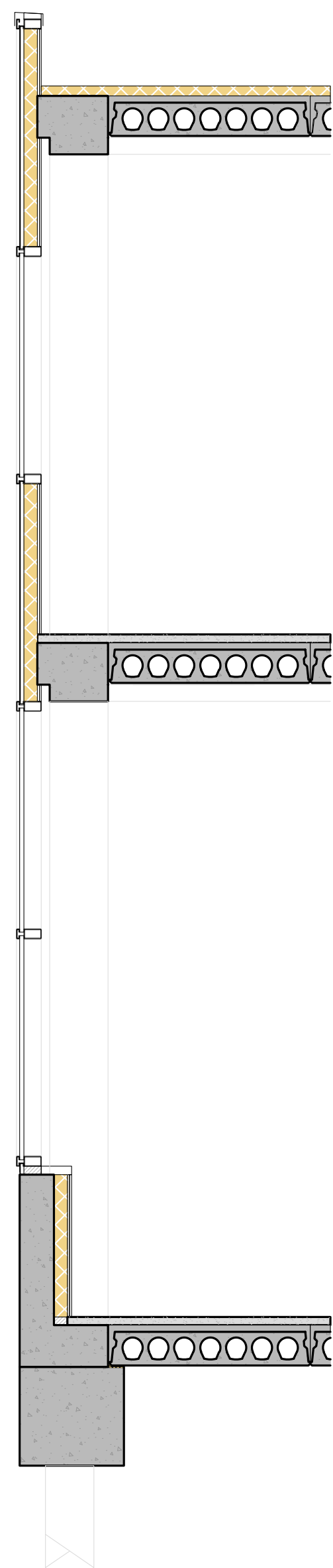

**ORIGINAL BUILDING**

Built in 1986



p = 7700

p = 7300

p = 4080

p = 0

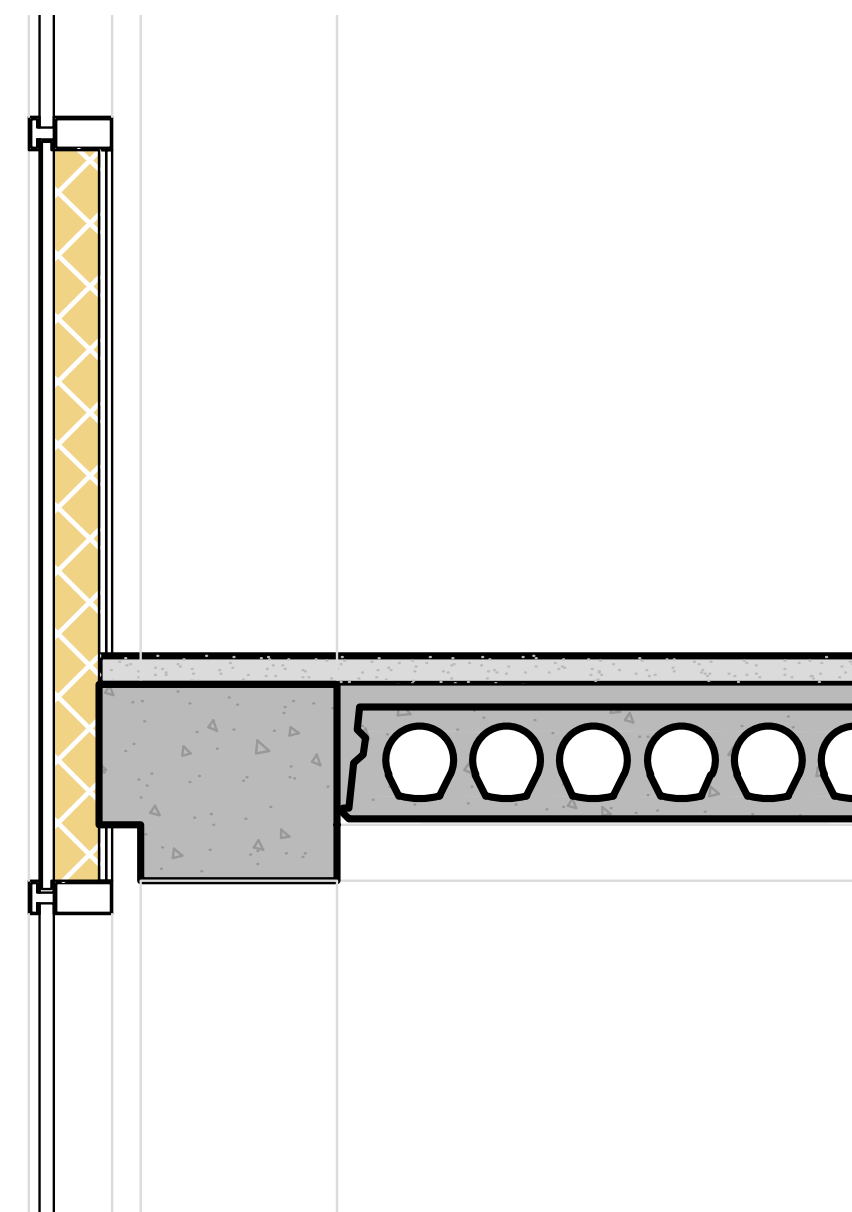
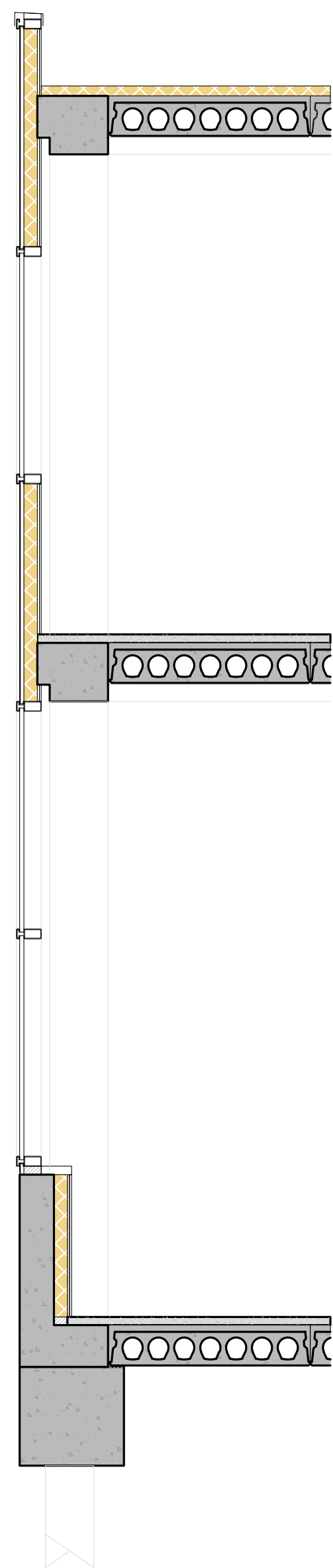

### ORIGINAL BUILDING

Built in 1986

p = 7700

p = 7300

p = 4080

p = 0

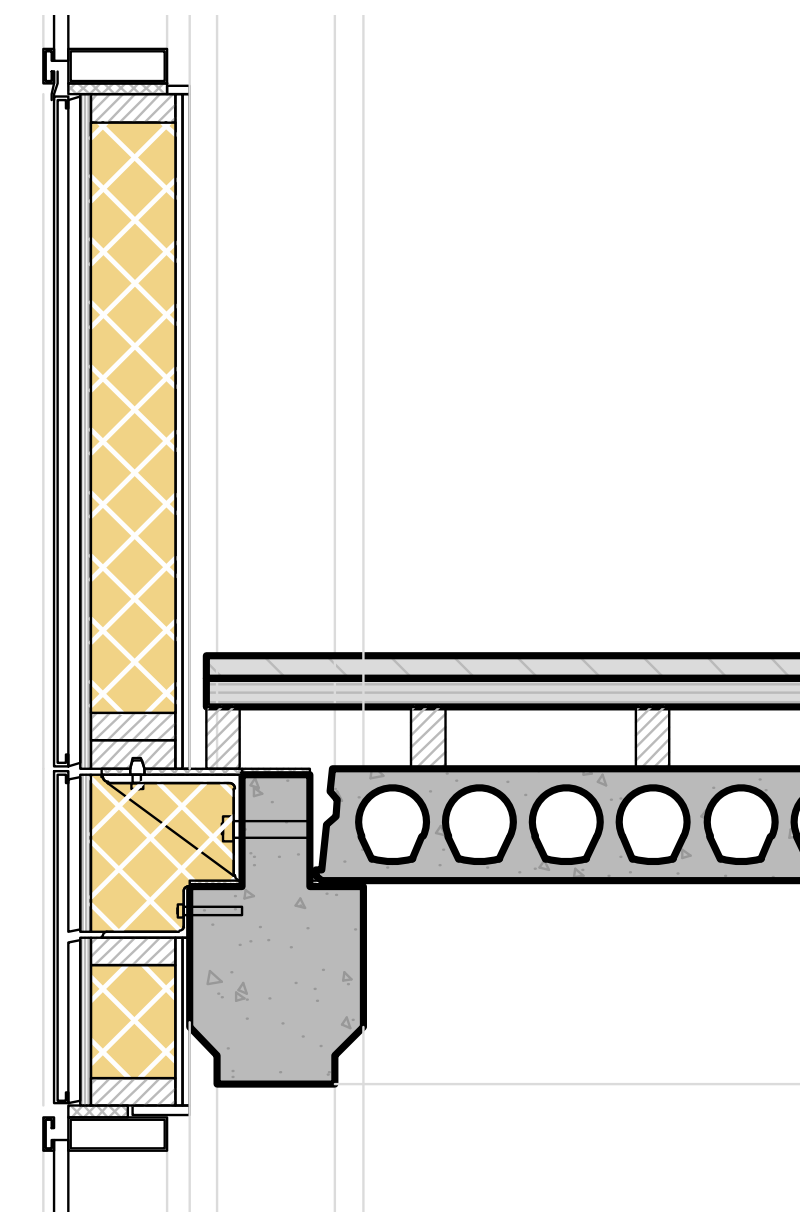
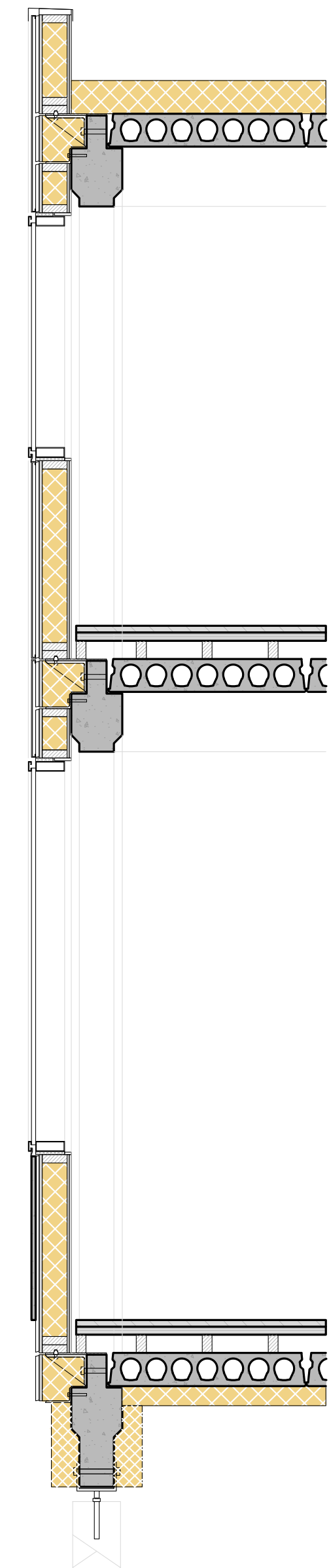

### CIRCLE BUILDING

2018 Concept



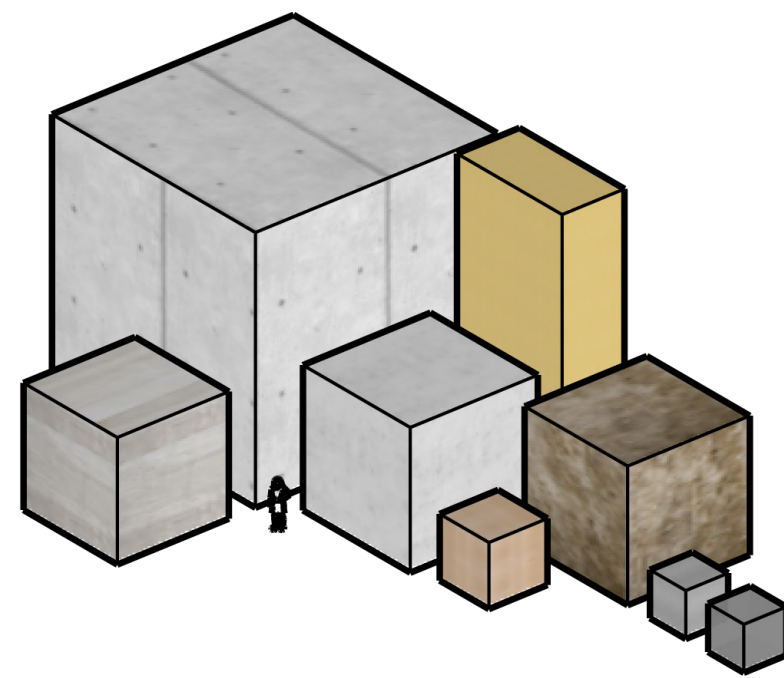

**1968**

The base model



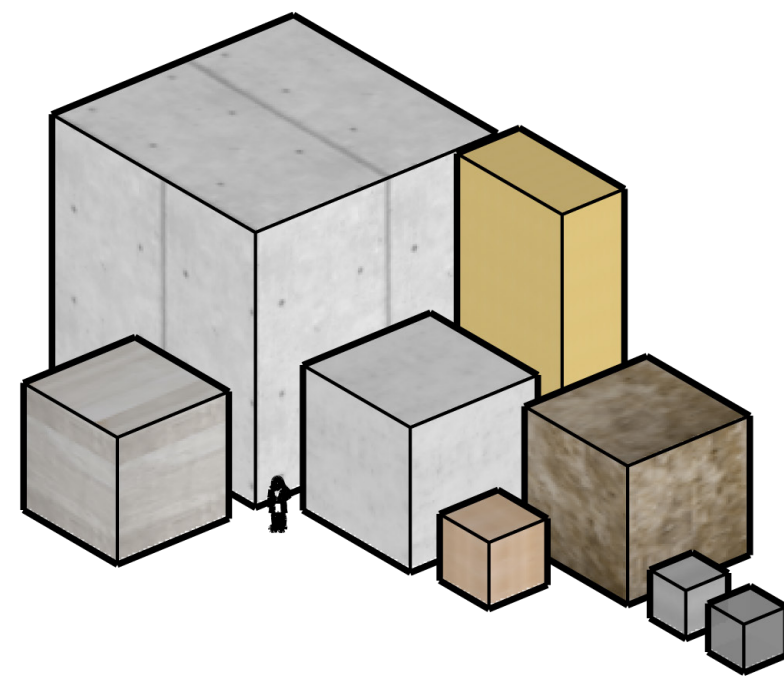

**1968**

The base model

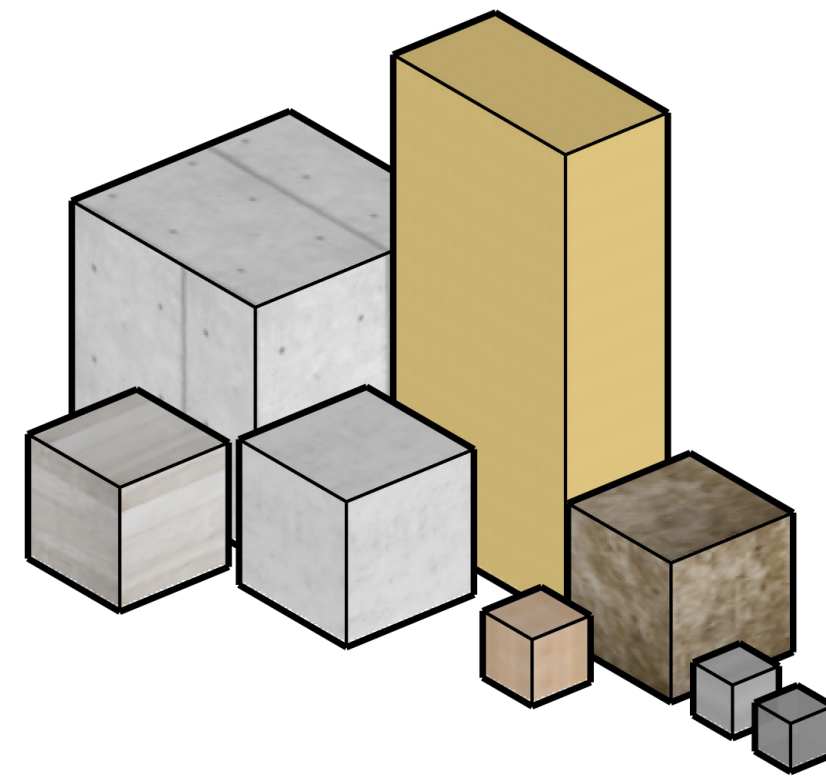

**2018**

Increased energy performance



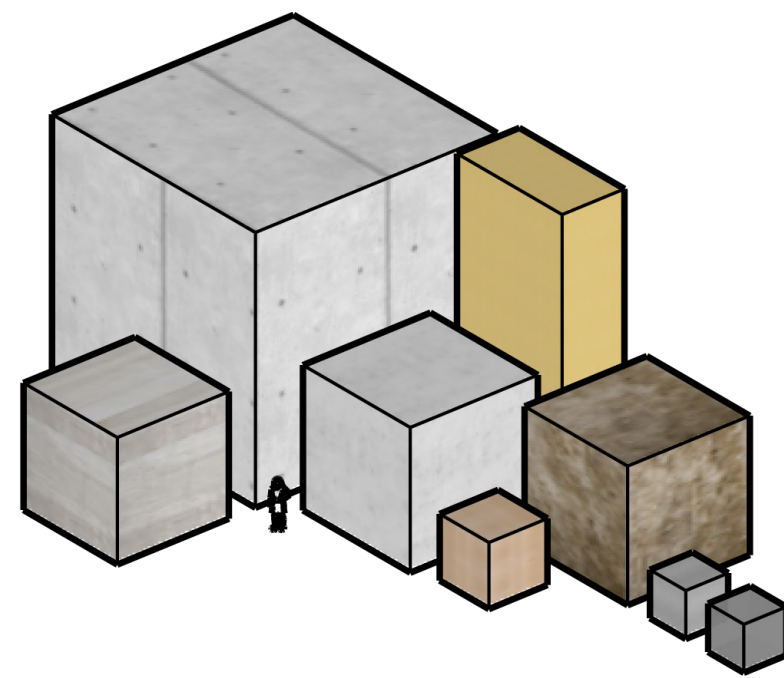

**1968**

The base model

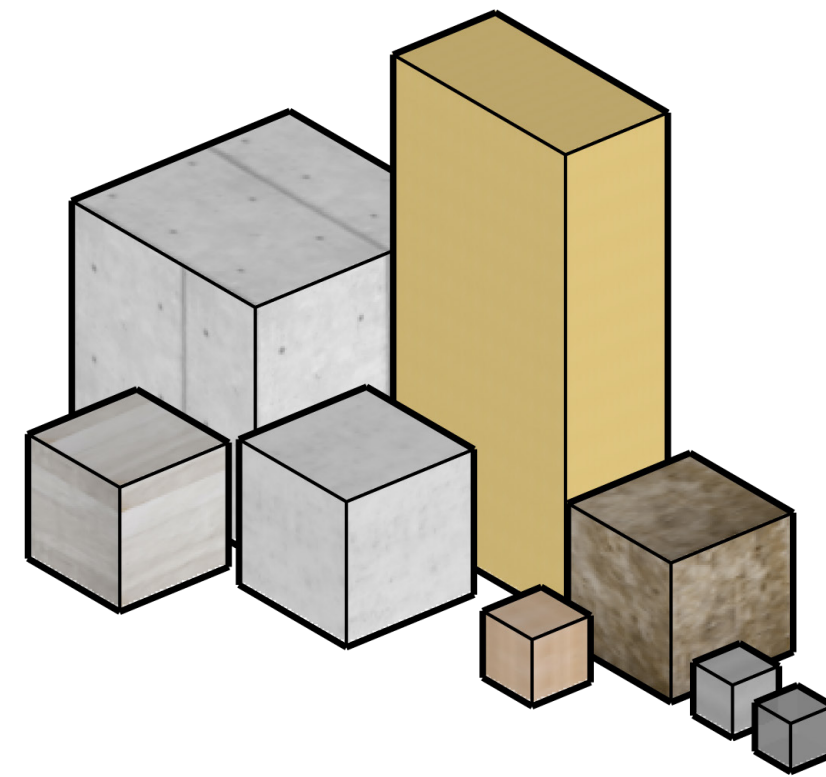

**2018**

Increased energy performance

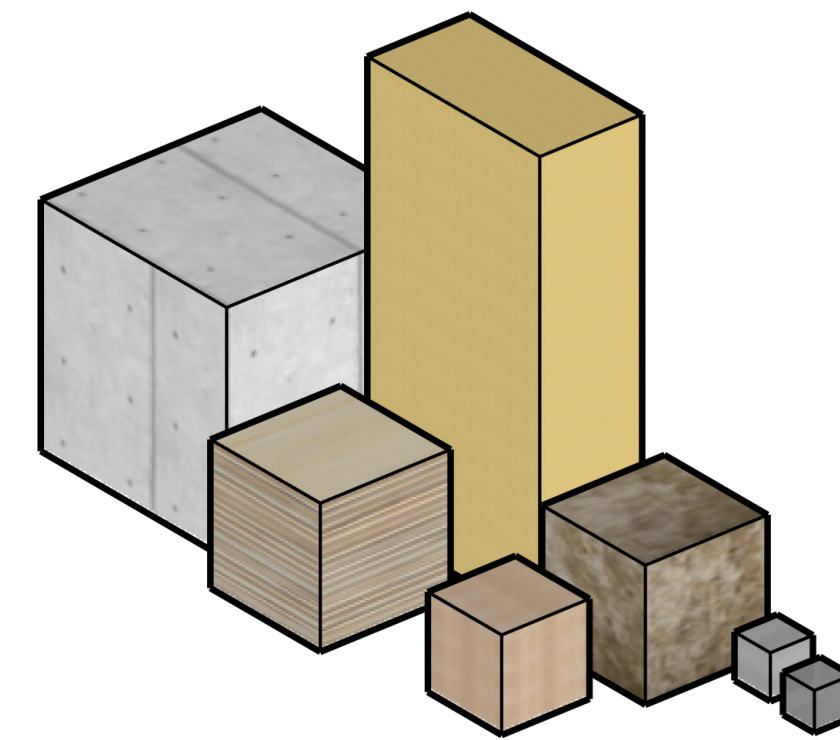

**CIRCLE**

Reversible construction  
Re-usable materials.



**RE-USE / RE-CYCLE**

Re-use Potential.

Modular Potential.

**WASTE**

% Re-cycle

% Landfill

% Incineration



# THE RE-USE AND RE-CYCLING POTENTIAL.

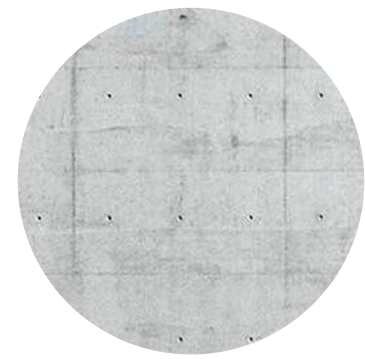

## CONCRETE

Reuse	low
Modular	high
Recycle	0.2%
Landfill	99.8%
Incineration	0%



## ROCKWOOL

Reuse	high
Modular	-
Re-cycle	95%
Landfill	5%
Incineration	0%



## PLASTERBOARD

Reuse	none
Modular	-
Re-cycle	5%
Landfill	95%
Incineration	0%



## SCREED

Reuse	none
Modular	-
Re-cycle	0%
Landfill	90%
Incineration	10%



## DRY WOOD

Reuse	low
Modular	high
Re-cycle	5%
Landfill	10%
Incineration	85%



## ALUMINIUM

Reuse	medium
Modular	medium
Re-cycle	80%
Landfill	15%
Incineration	5%



## POLYSTYRENE

Reuse	medium
Modular	-
Re-cycle	5%
Landfill	90%
Incineration	5%



## PLYWOOD

Reuse	low
Modular	high
Re-cycle	10%
Landfill	5%
Incineration	85%



## FLOAT GLASS

Reuse	none
Modular	-
Re-cycle	70%
Landfill	30%
Incineration	0%

# THE RE-USE AND RE-CYCLING POTENTIAL.

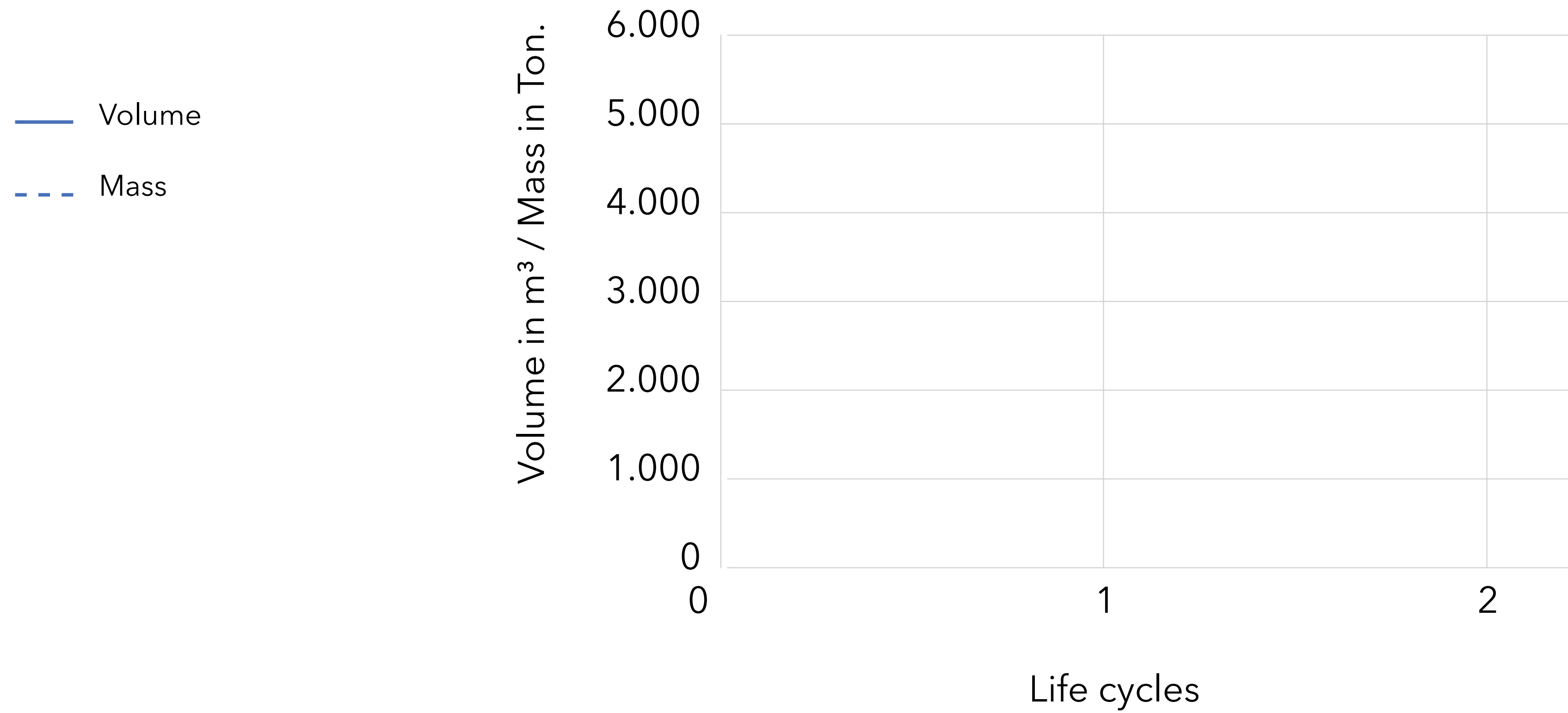



# THE RE-USE AND RE-CYCLING POTENTIAL.

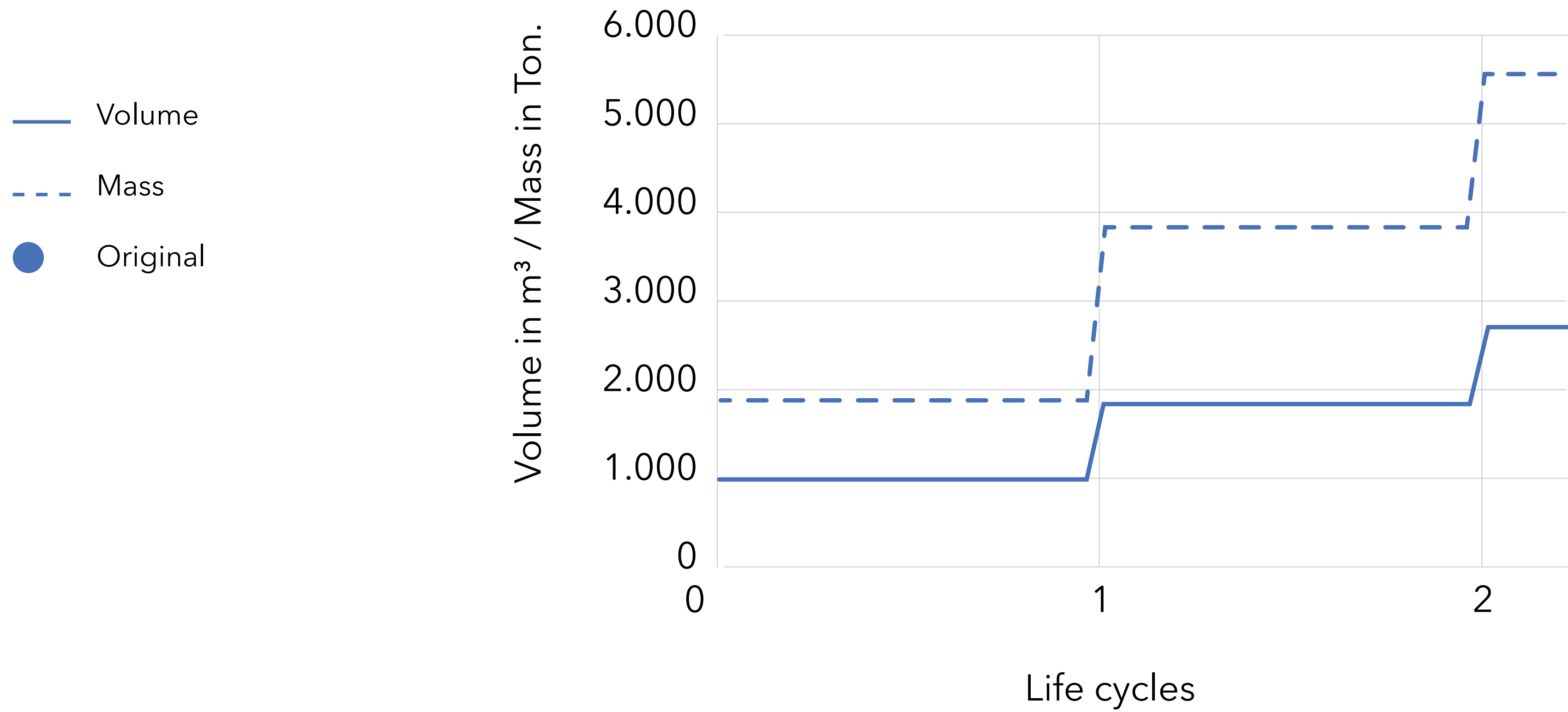

# THE RE-USE AND RE-CYCLING POTENTIAL.

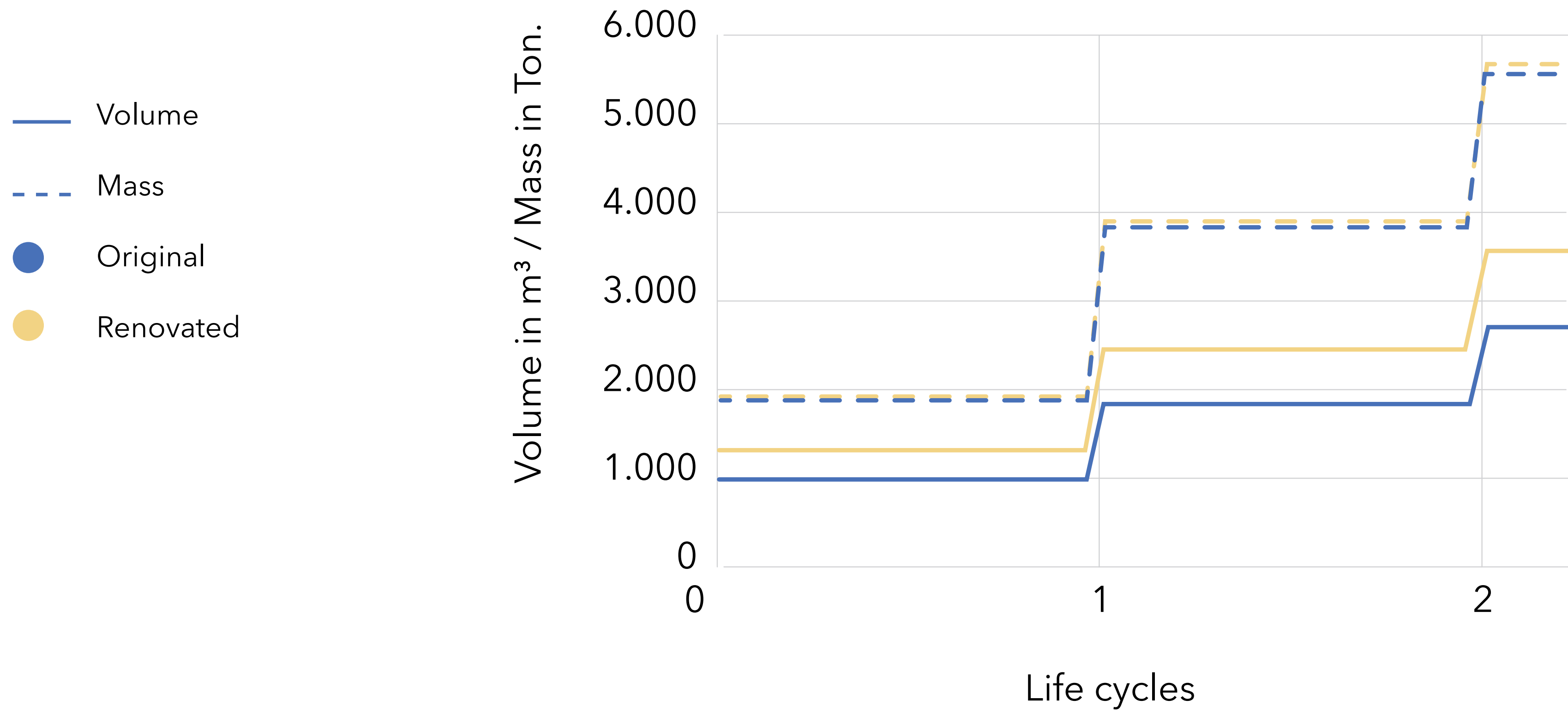



# THE RE-USE AND RE-CYCLING POTENTIAL.

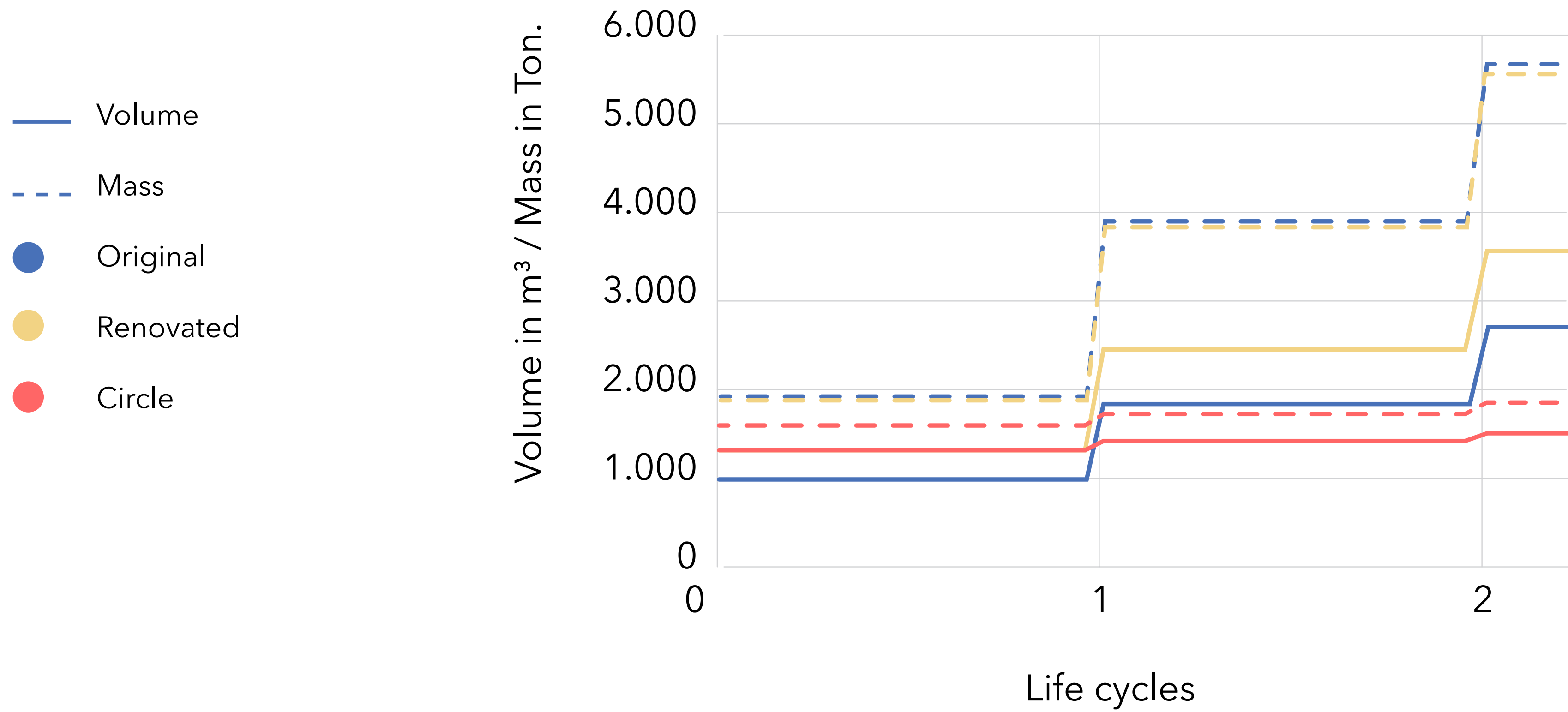

# THE RE-USE AND RE-CYCLING POTENTIAL.

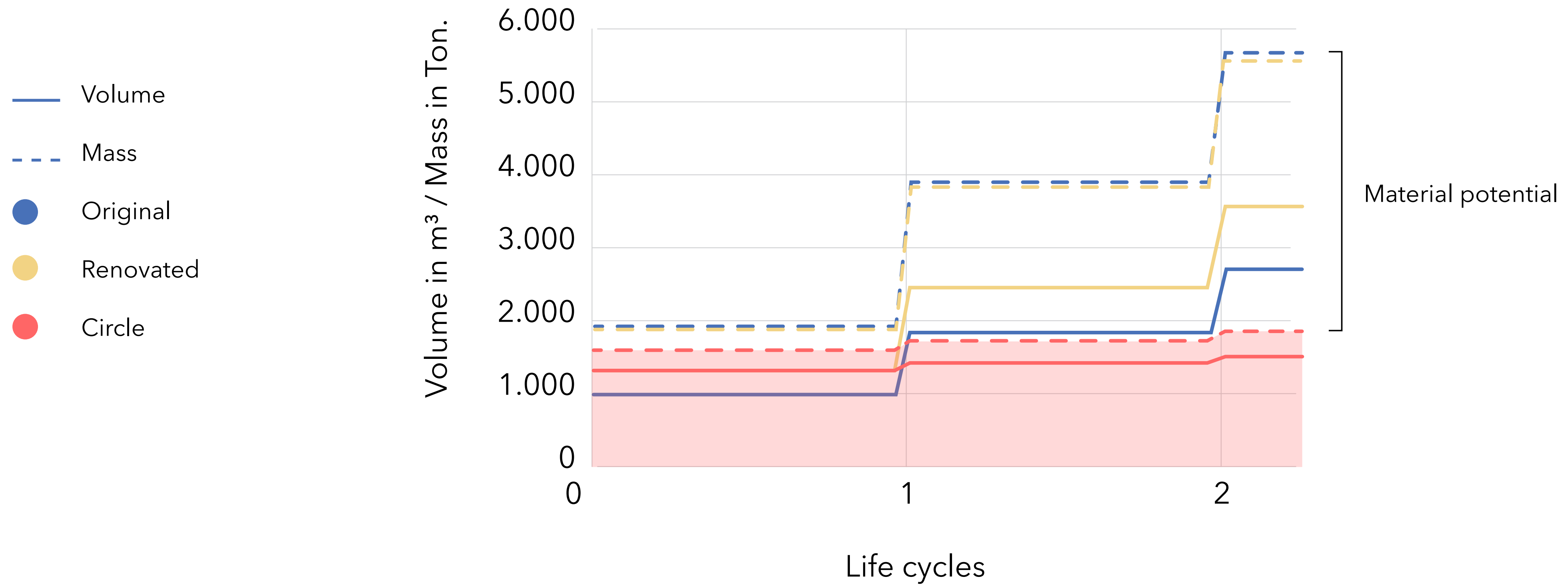



# RESEARCH : CONCLUSIONS

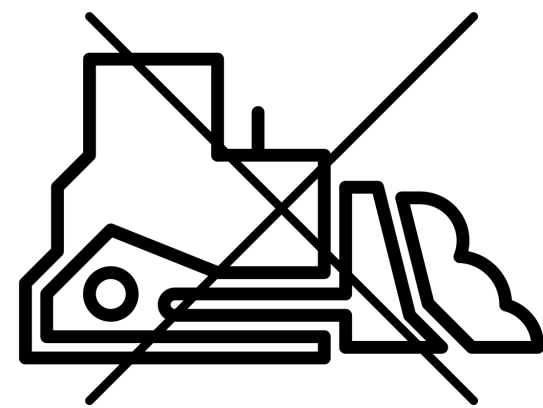

## **NO SINGLE-USE MATERIALS**

Keep materials separated.  
Simplify the process to re-cycle  
and re-use building materials.  
Avoid certain materials.

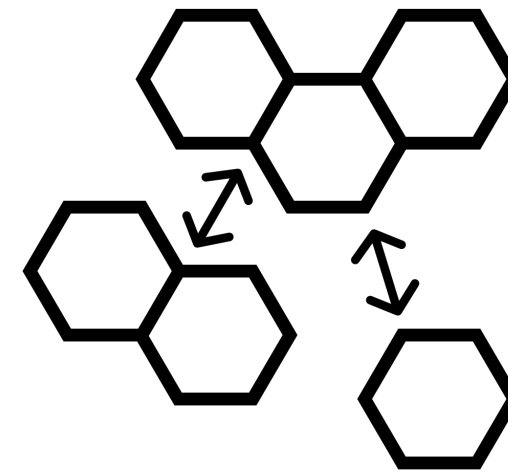

## **REVERSIBLE CONNECTIONS**

Use reversible connections.  
Communicate materials with  
passports.

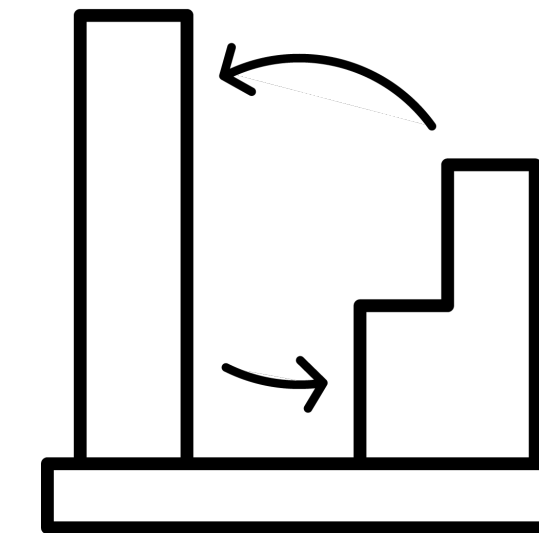

## **ON-SITE REASSEMBLY**

On site development and re-  
development.  
Take materials from case study.



**UPCYCLE AMSTEL**

Amstel III  
re-cycle, re-use  
Waste & Up-cycle  
Design for Disassembly.



**RESEARCH**

Case Study  
Material Potential

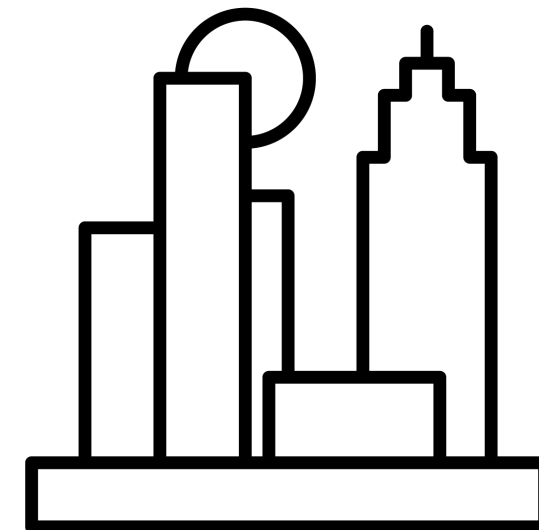

**URBAN PLAN**

Amstel III  
Main street  
Park

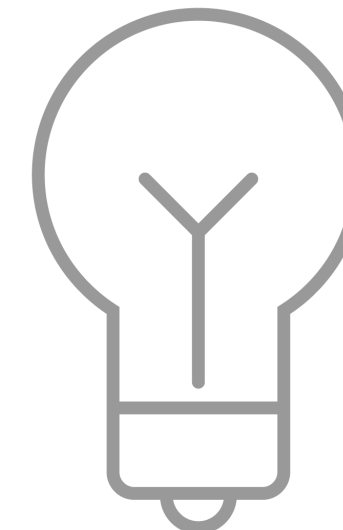

**CONCEPT**

Cultural Meeting spot.  
Circular Demonstrator.  
Innovation hub.

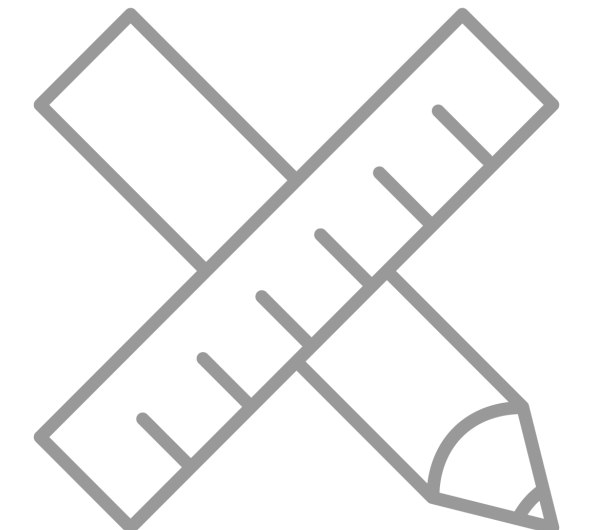

**DESIGN**

Program  
Volume study.



# NEIGHBORHOOD



**AMSTEL III NOW**

Office district



**AMSTEL III VISION**

Mixed Urban City.



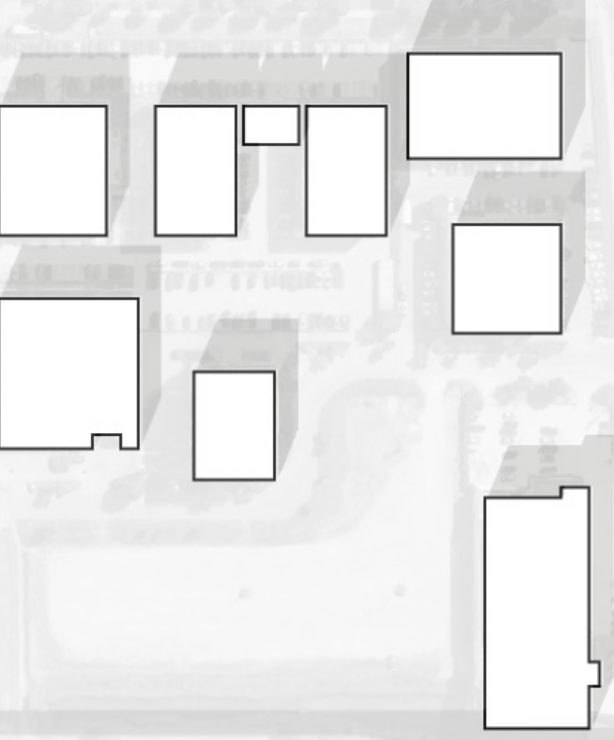
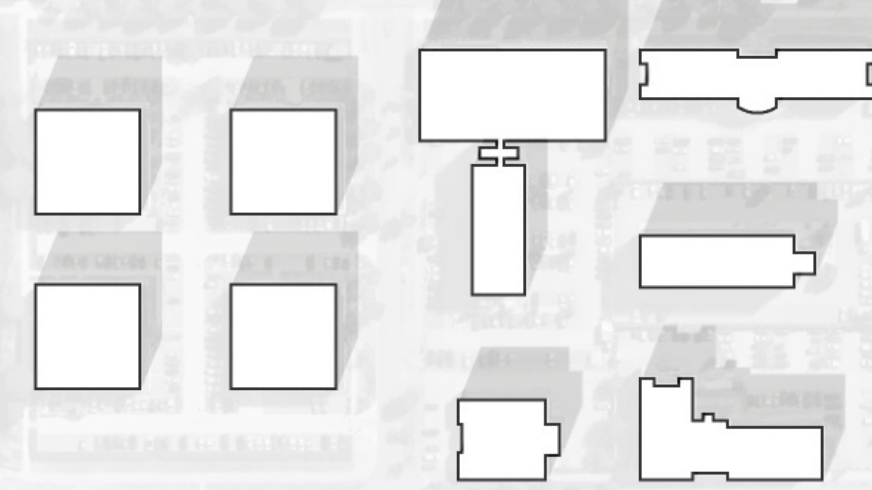
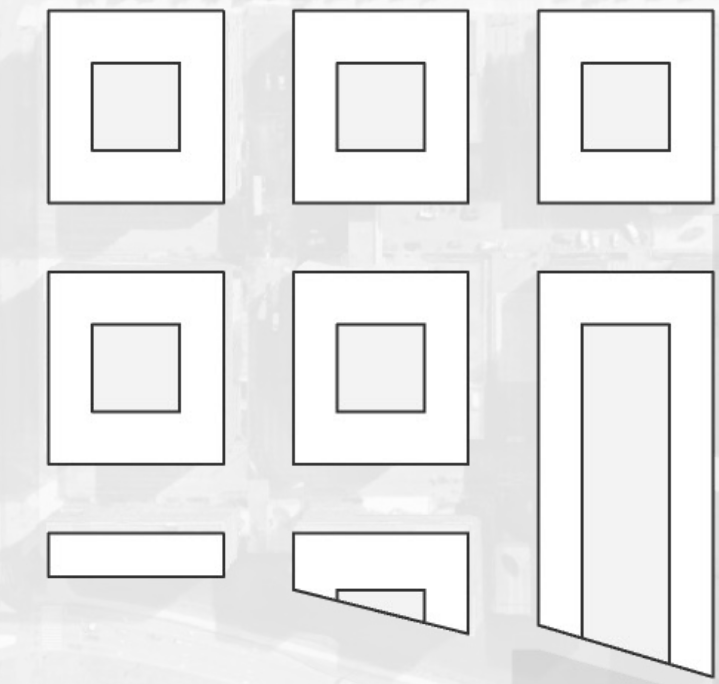
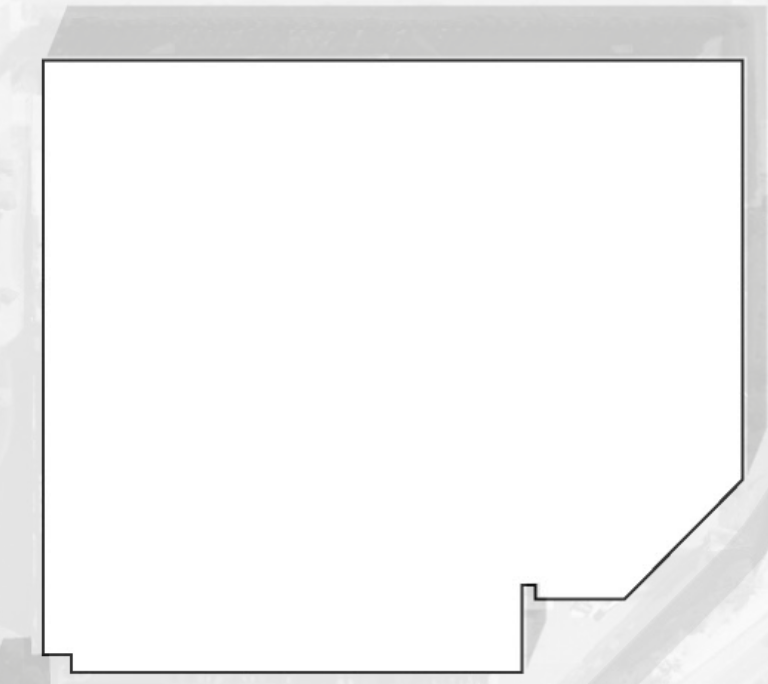
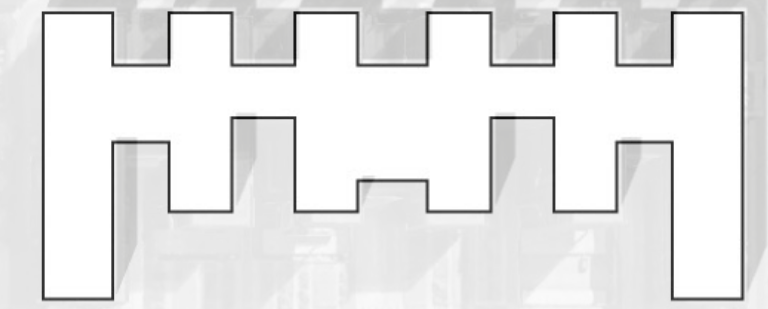
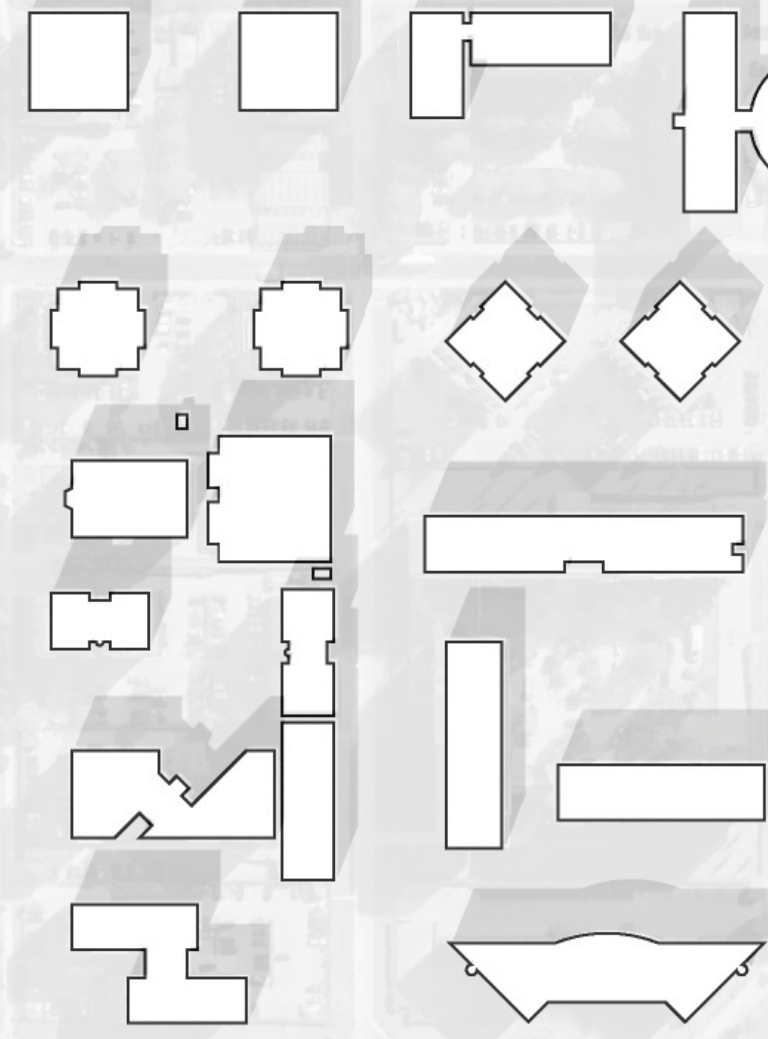
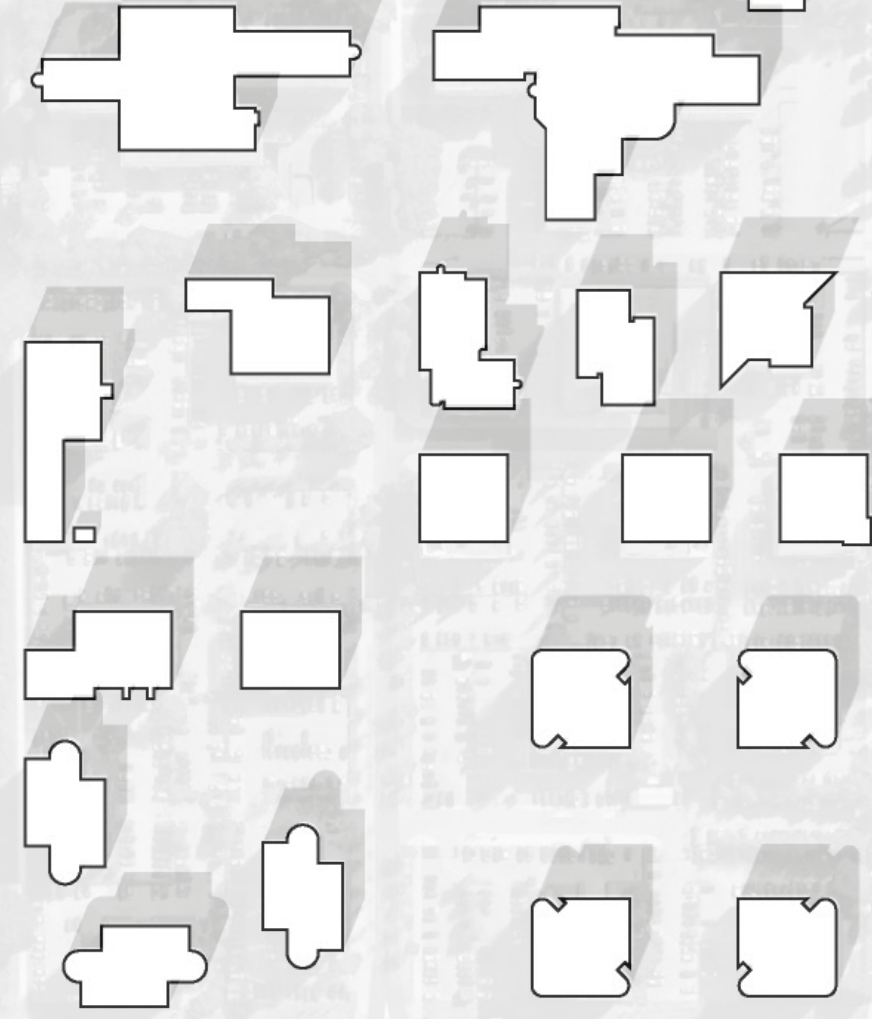
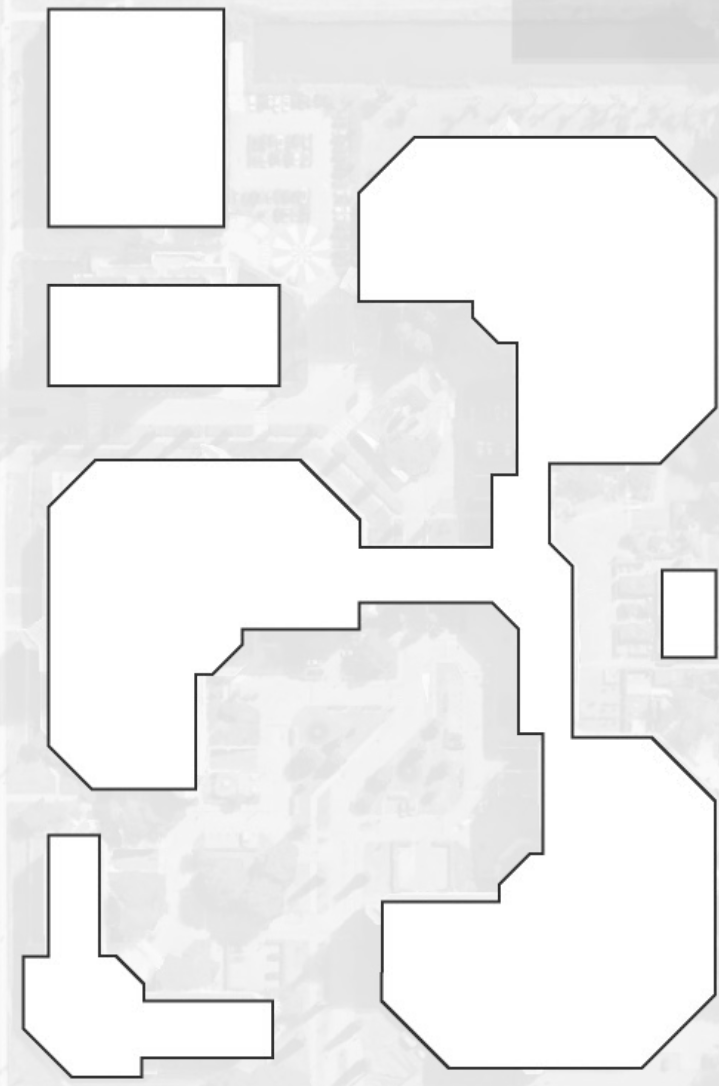



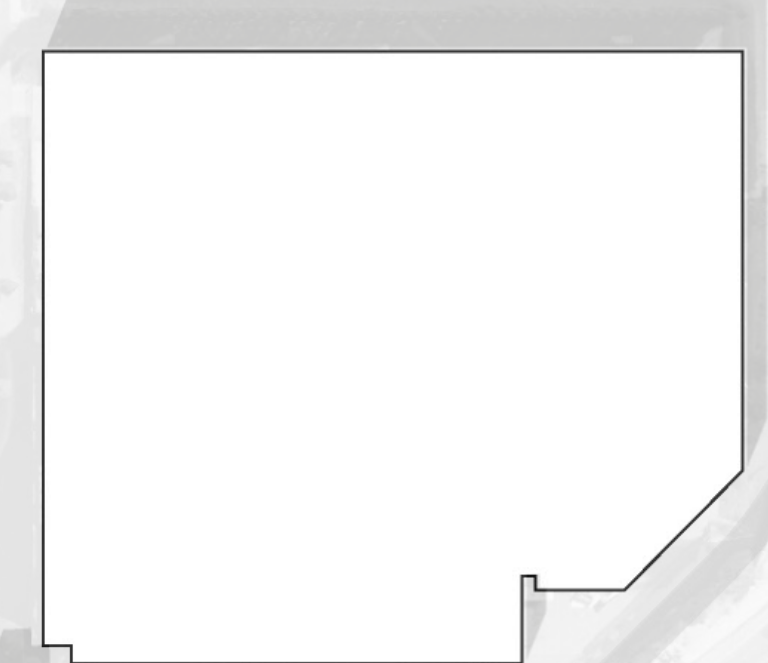
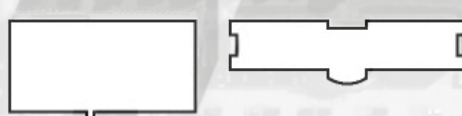
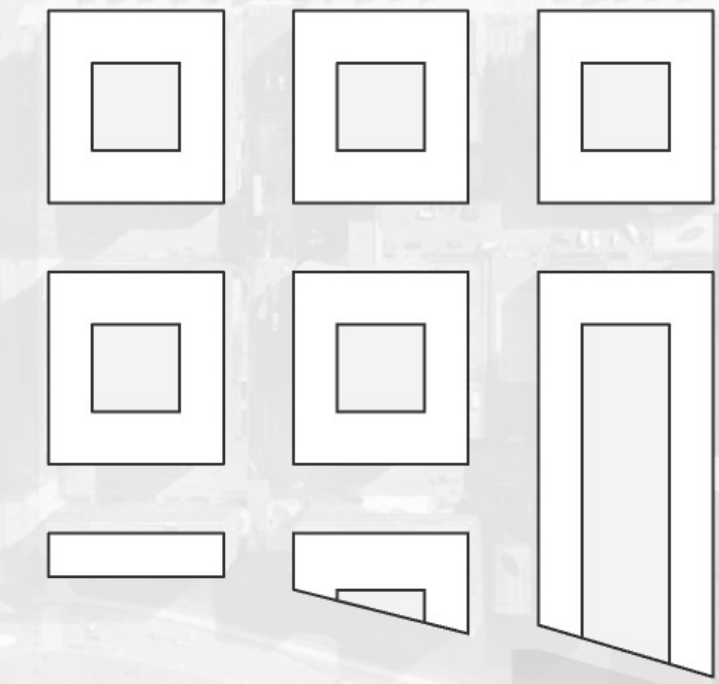
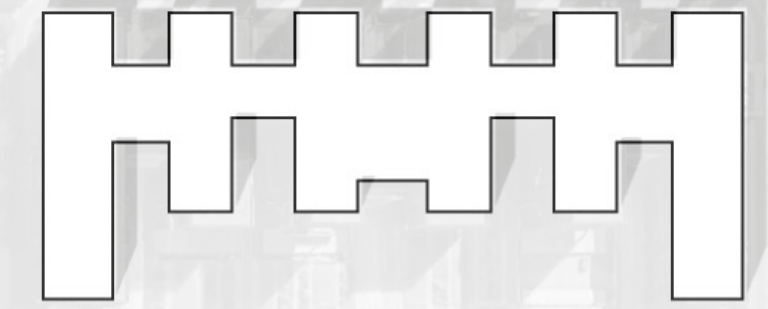
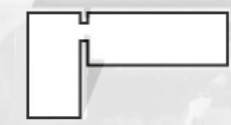
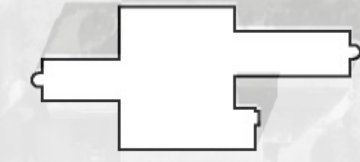
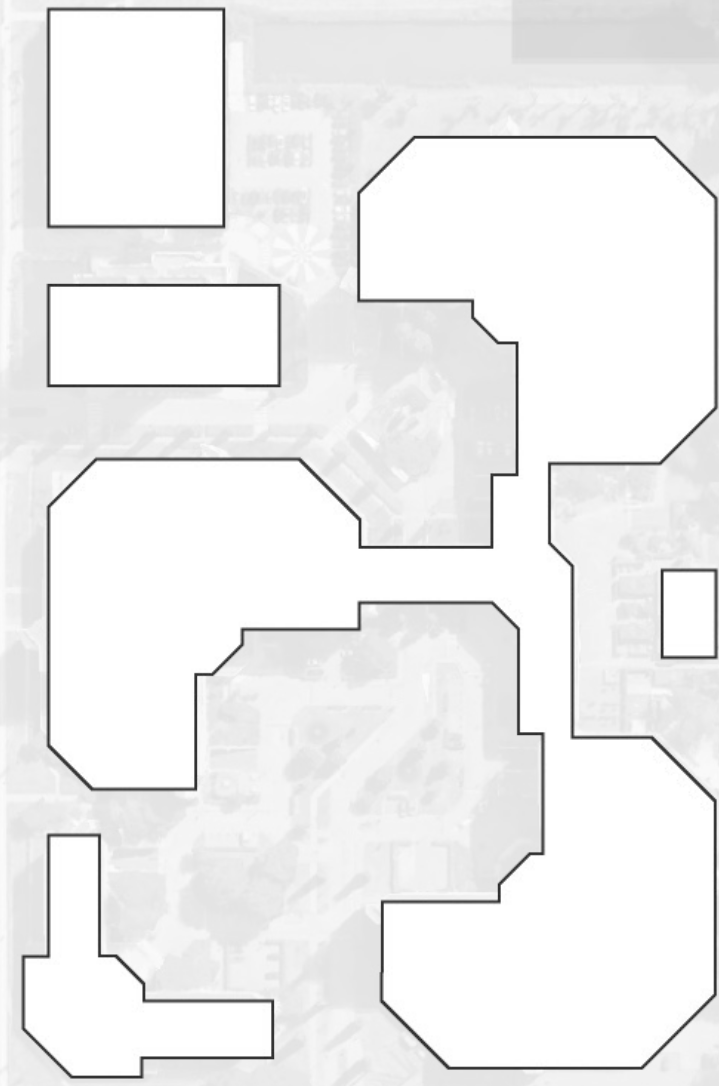



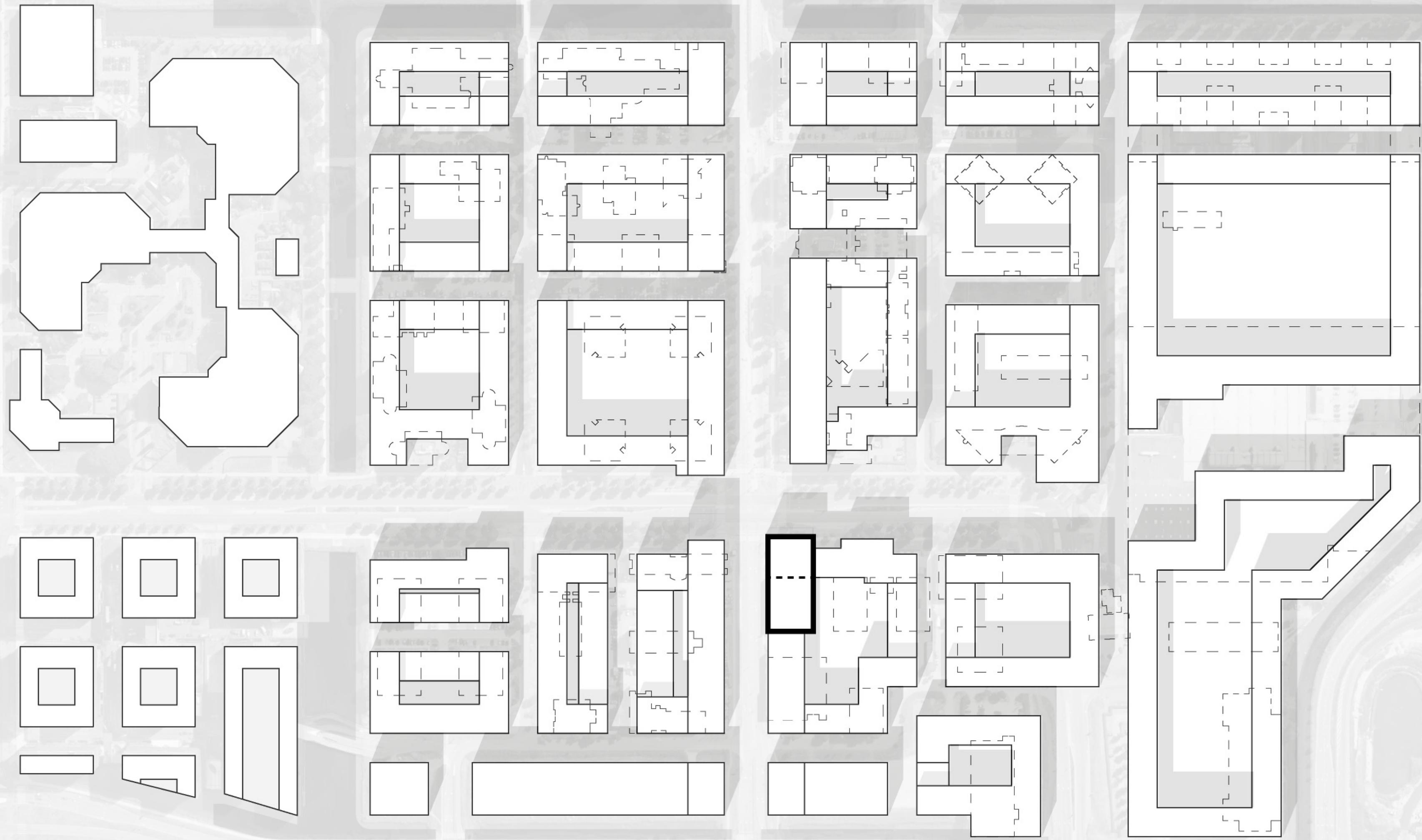

Clear street profiles  
Increase in volume.  
No parking on streets.





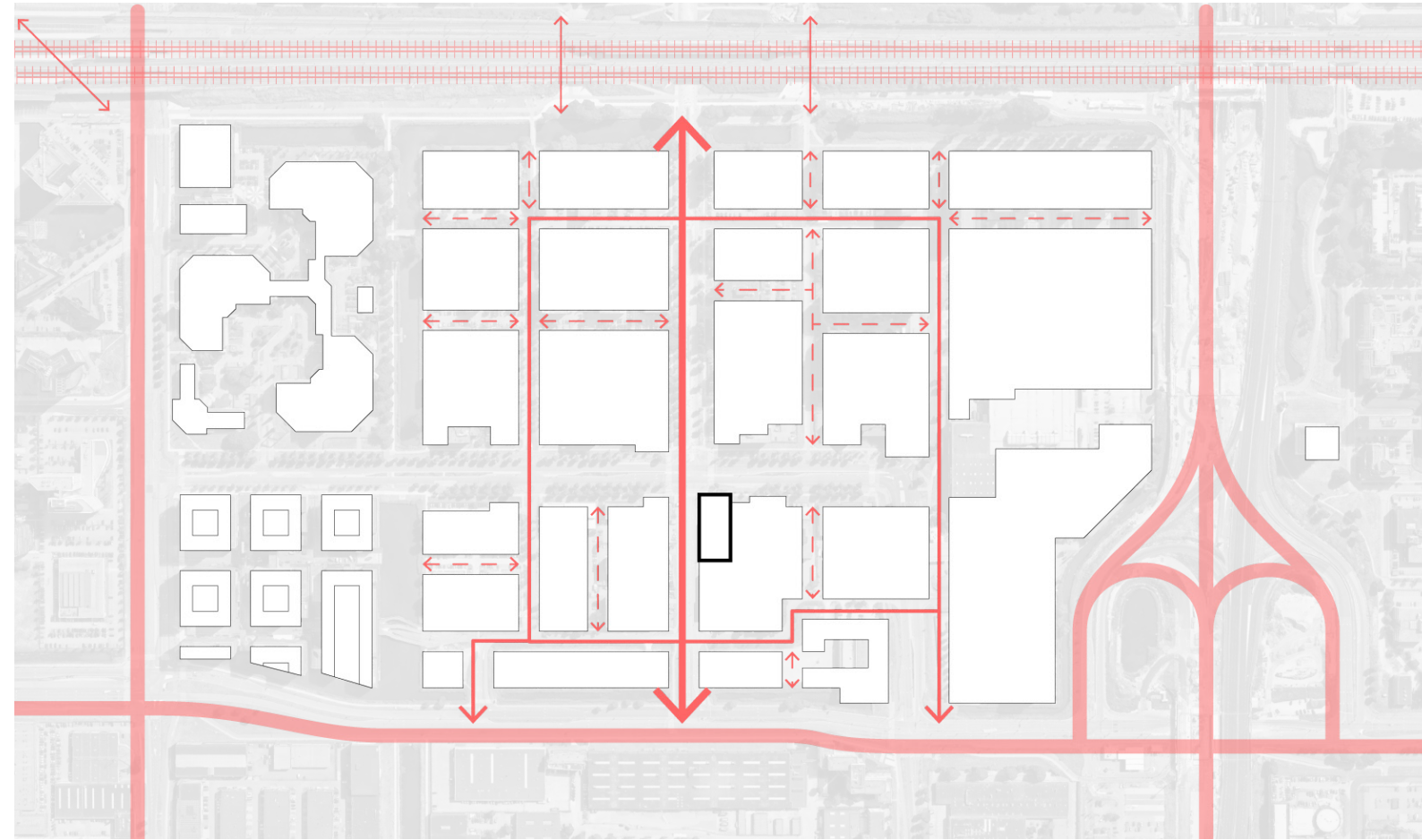

## **TRAFFIC**

Public transport acces from east.  
Main highway next to the district.  
Smaller routes through the area.



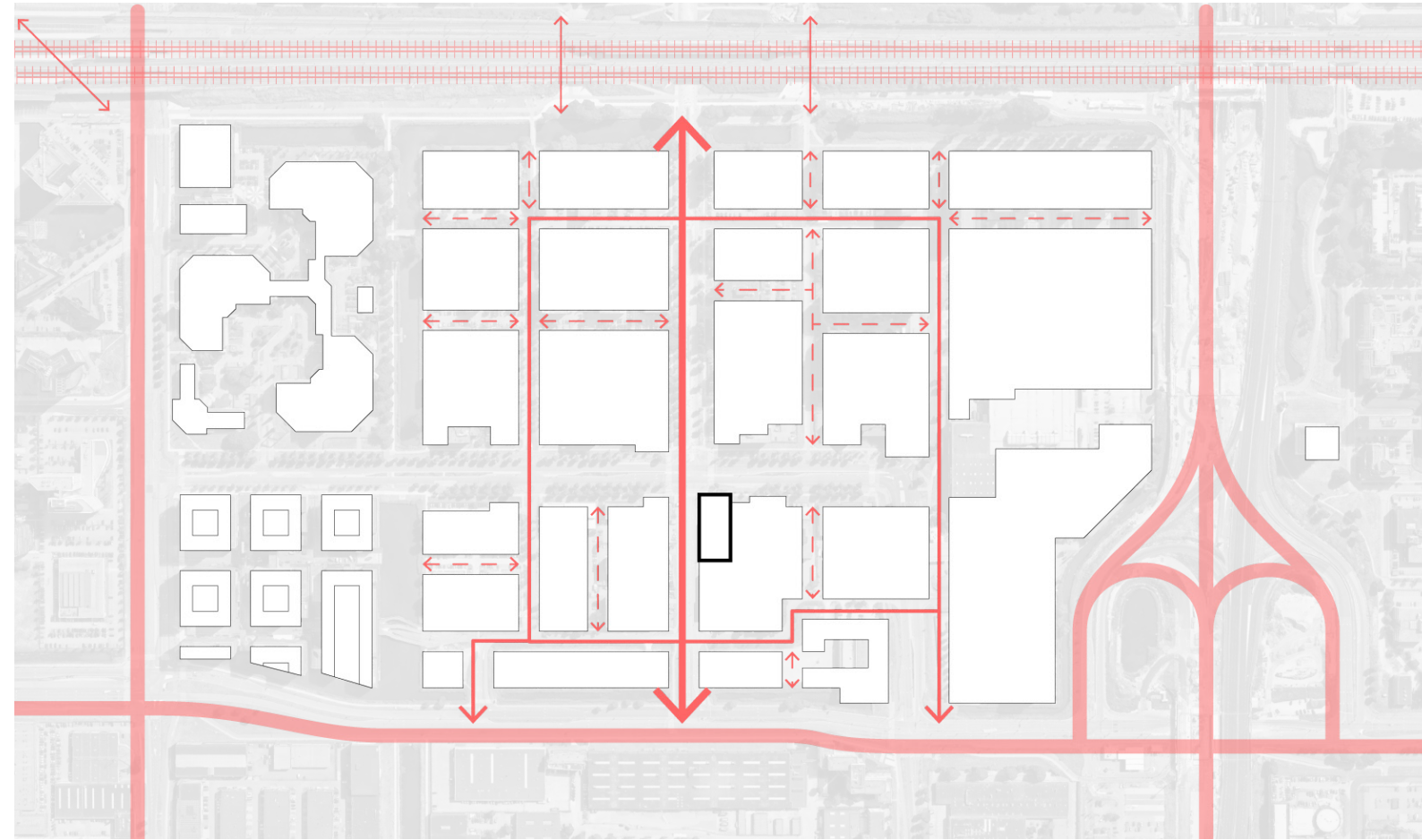

### **TRAFFIC**

Public transport acces from east.  
Main highway next to the district.  
Smaller routes through the area.

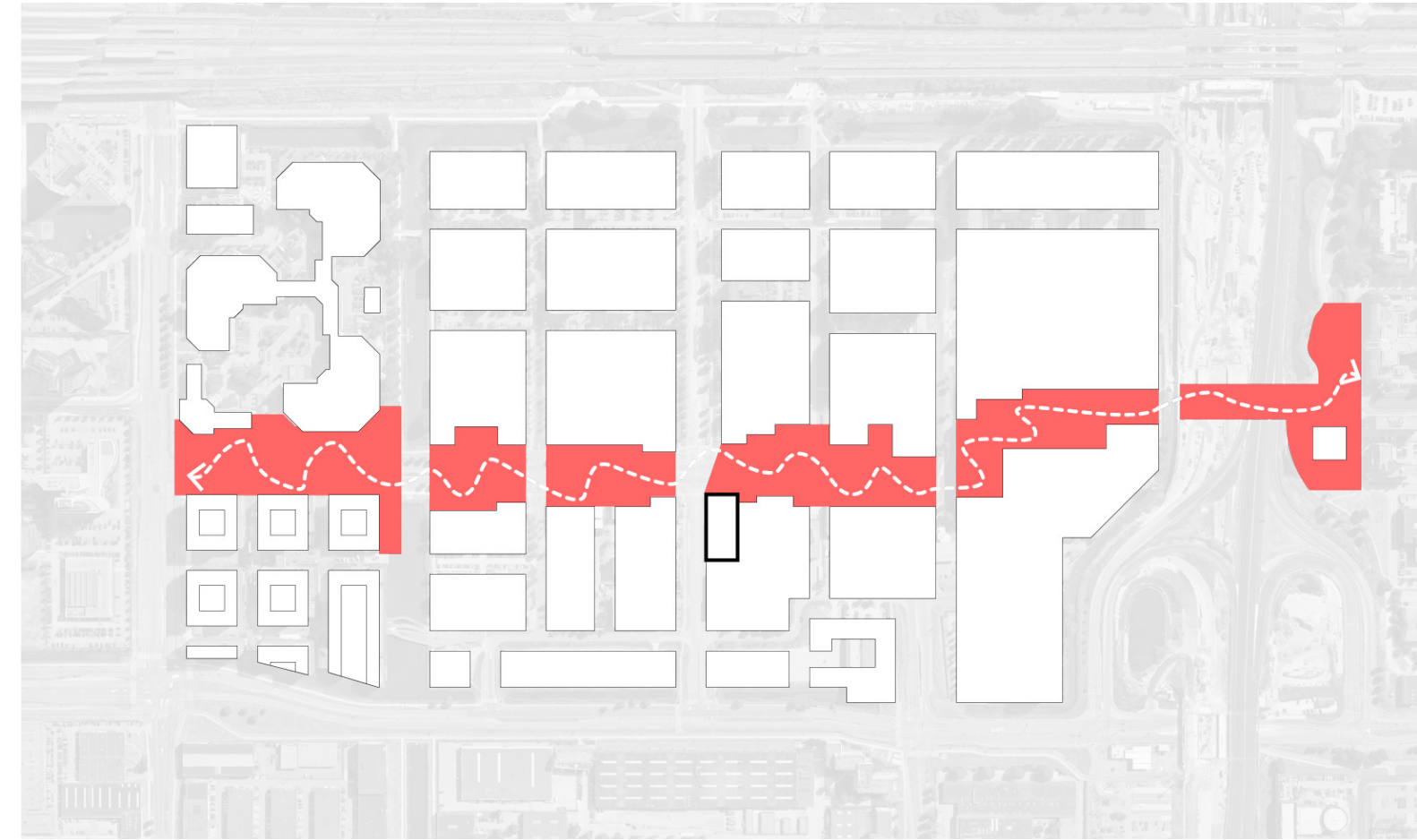

### **NEW PARK**

New Central green strip / central  
park.  
Quiet place for sports and  
relaxation.



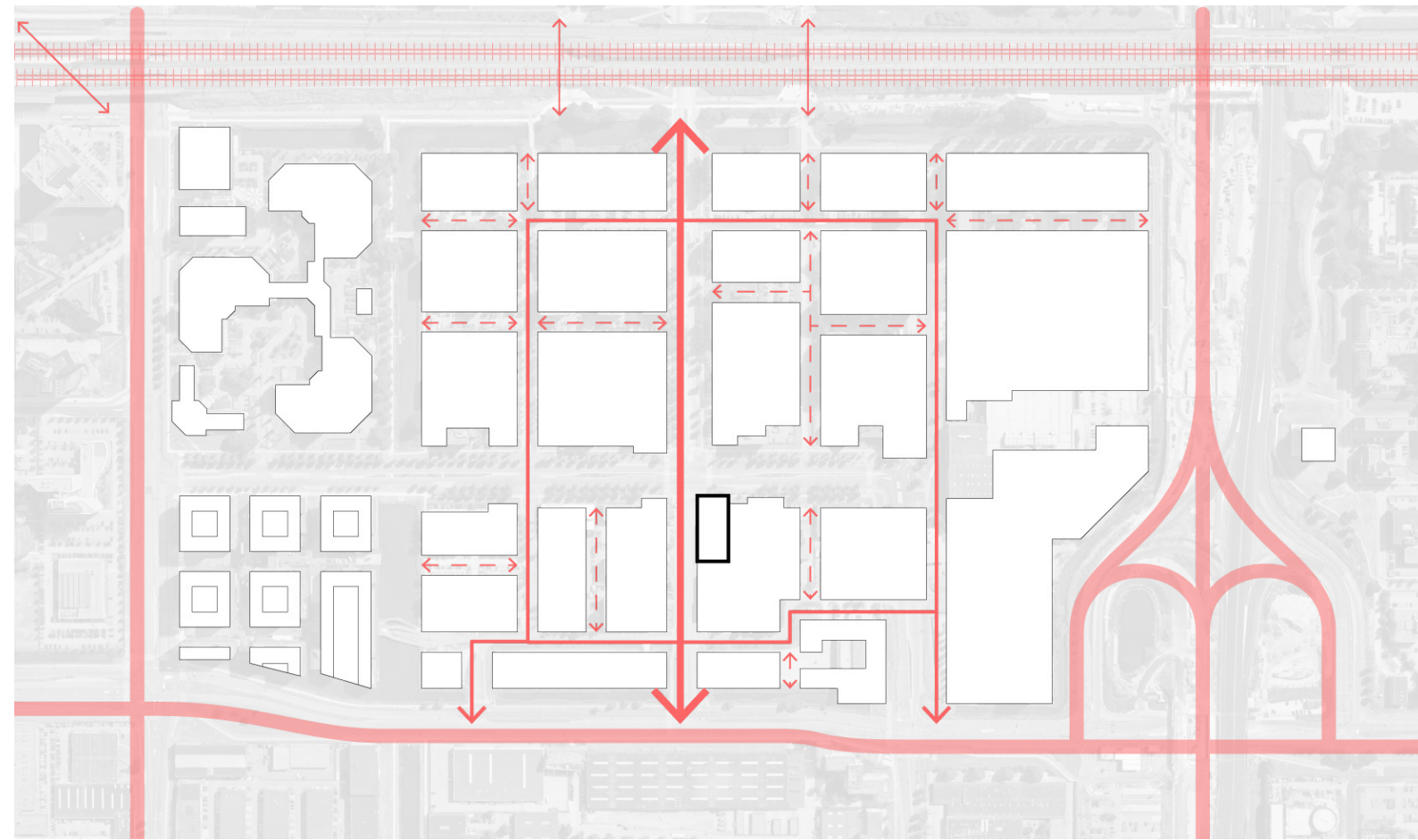

### **TRAFFIC**

Public transport acces from east.  
Main highway next to the district.  
Smaller routes through the area.

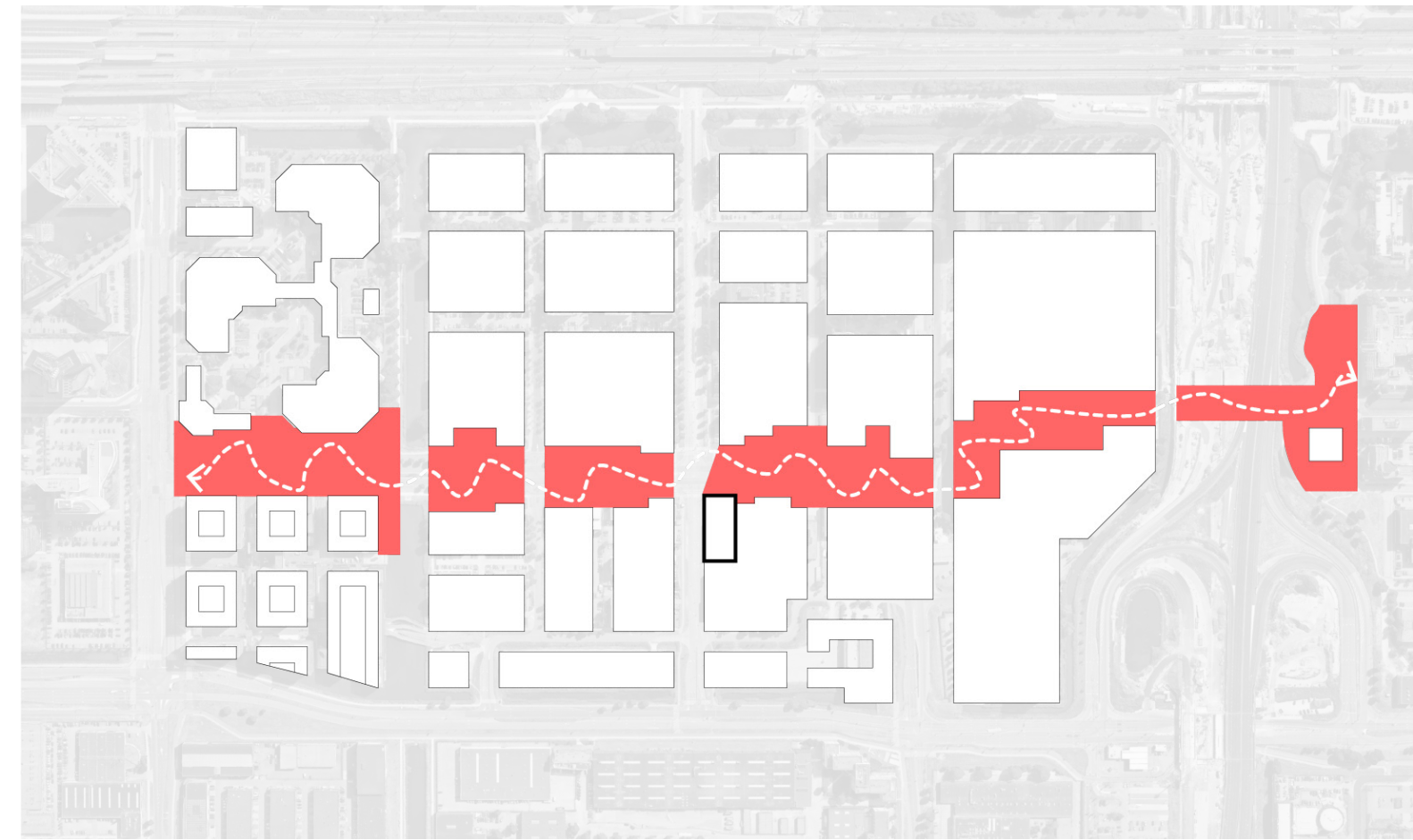

### **NEW PARK**

New Central green strip / central  
park.  
Quiet place for sports and  
relaxation.

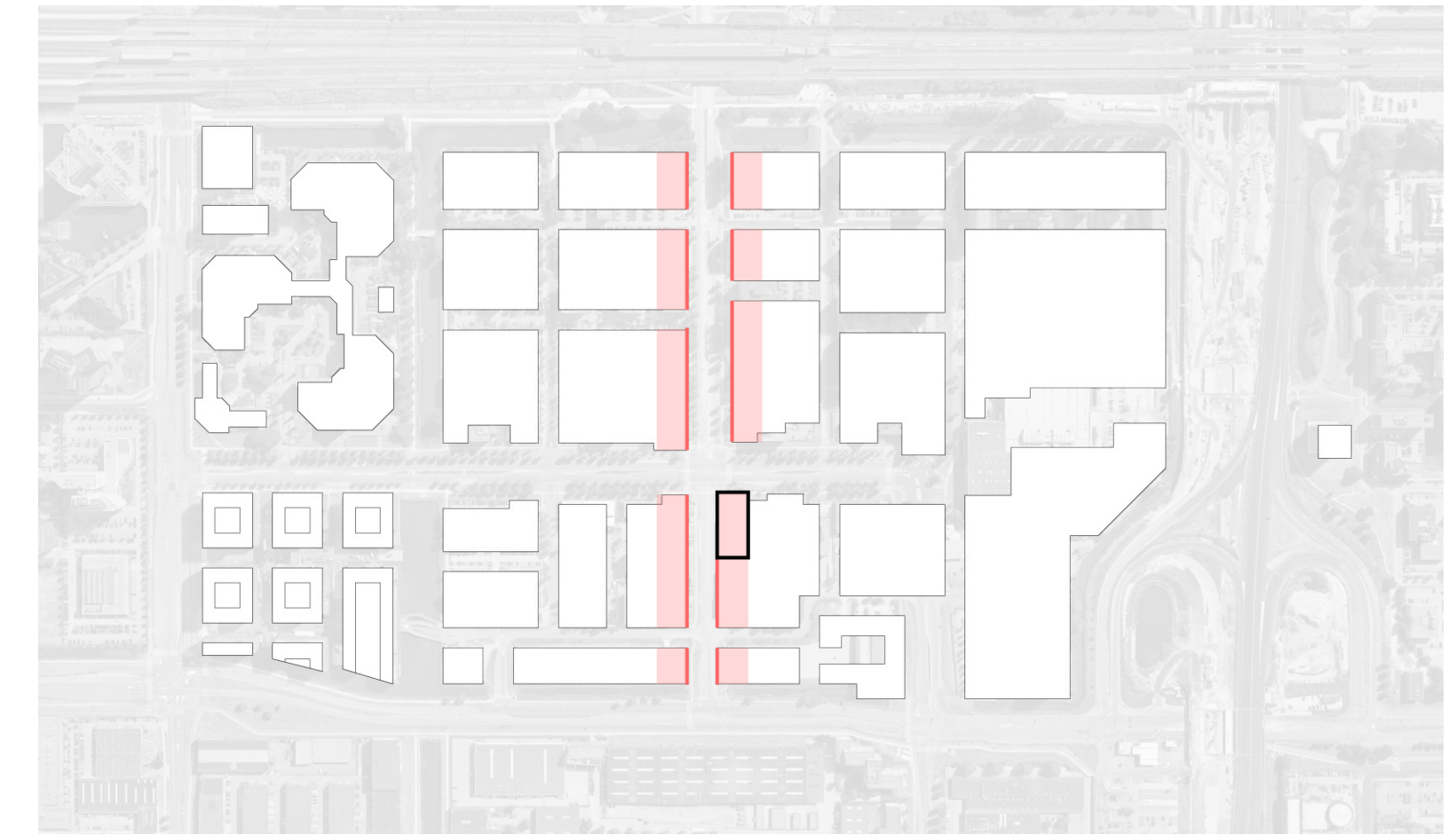

### **MAIN PUBLIC ROUTE**

Main street.  
Stores and supermarkets.  
Cafe and public meeting points  
on the corners.



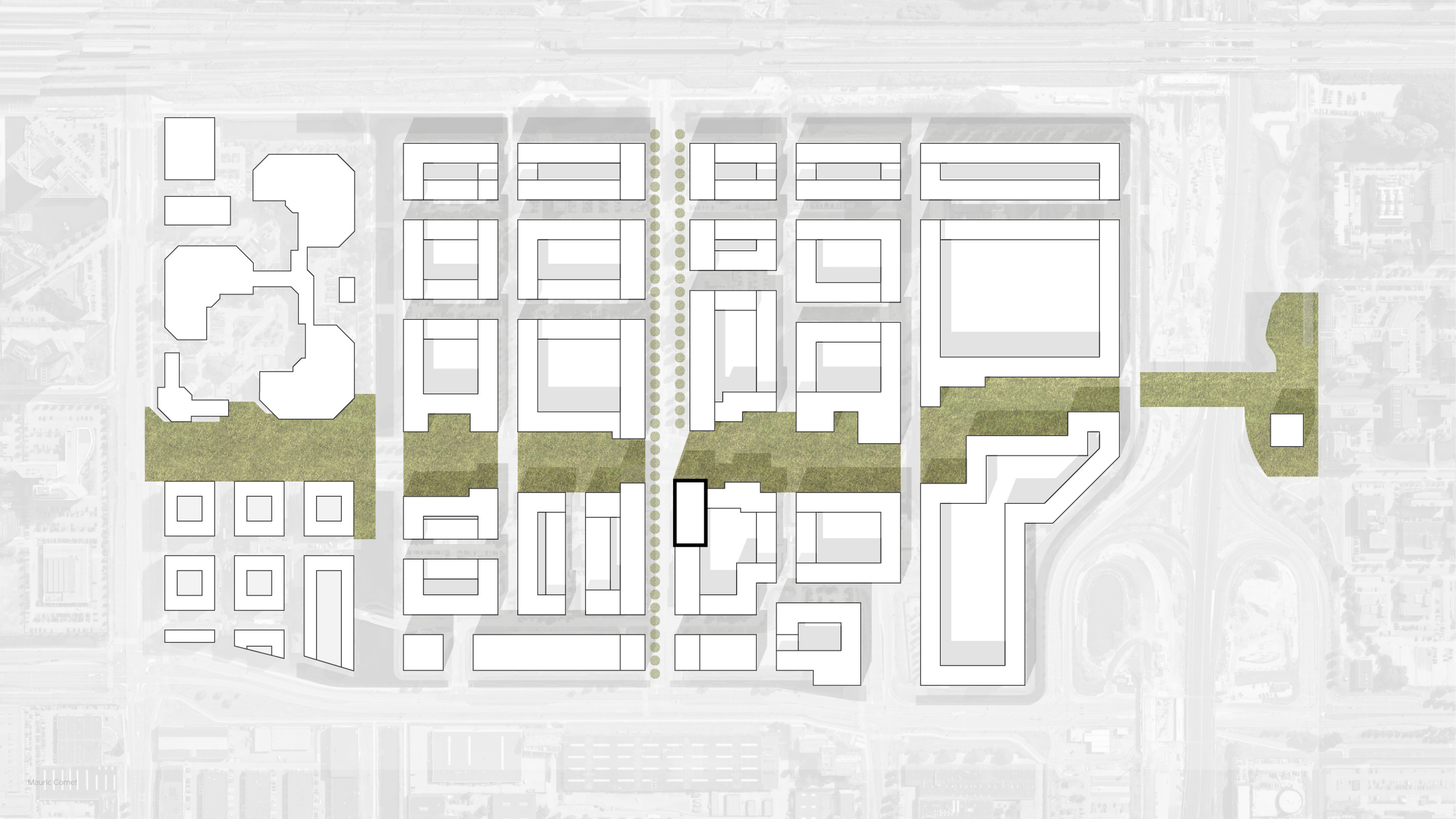



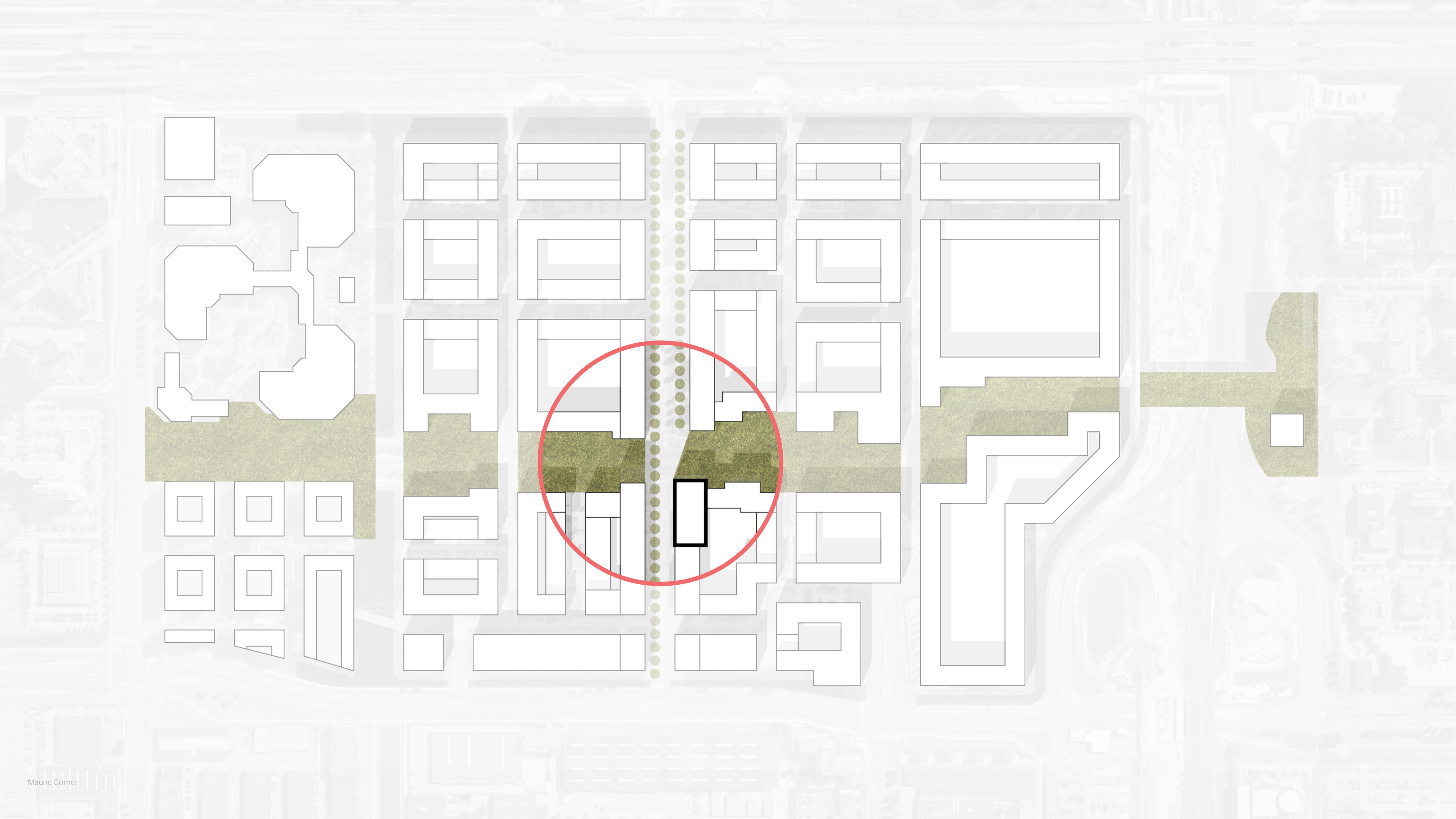



# SITE

Station Access

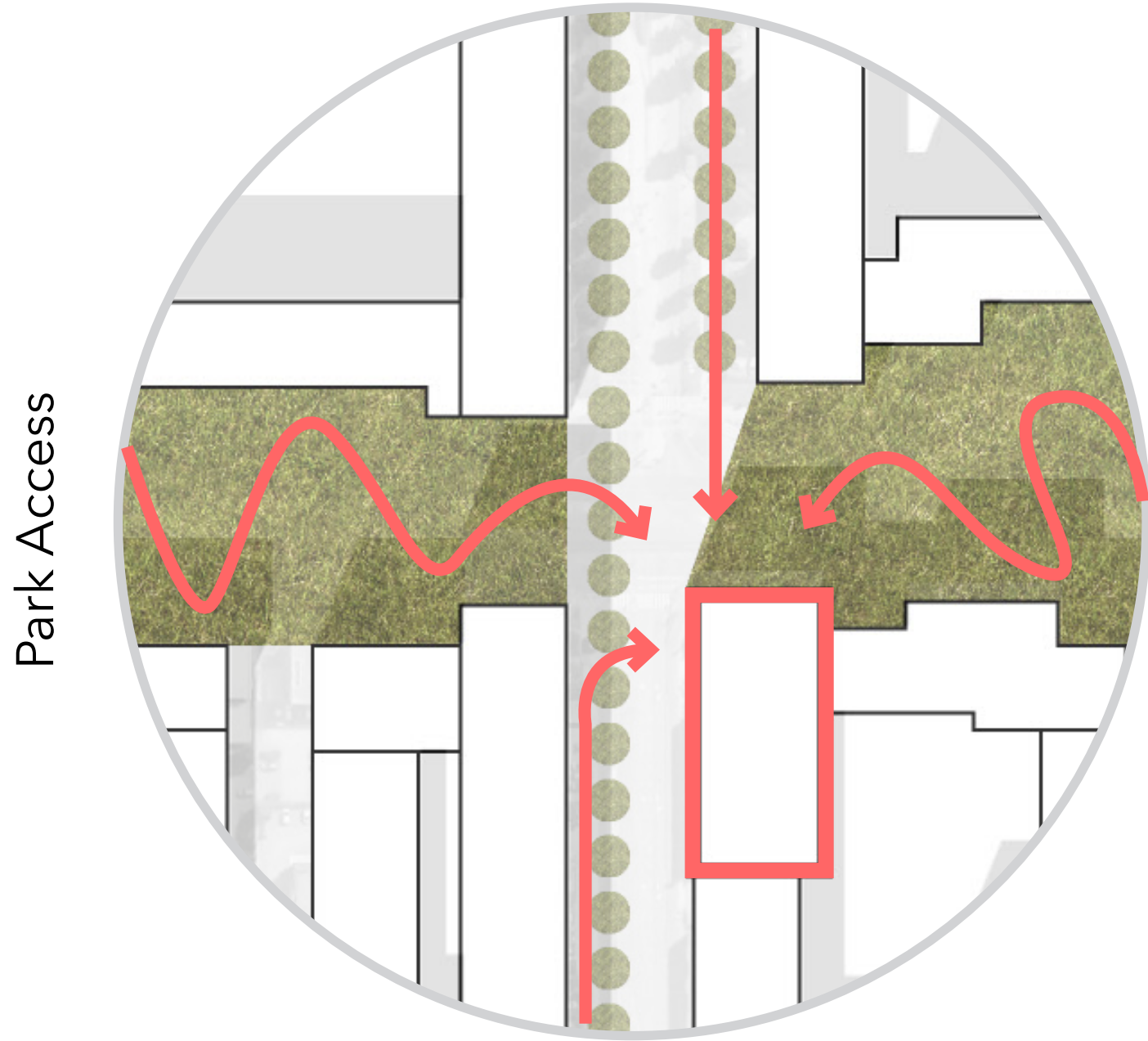

Main street Access.

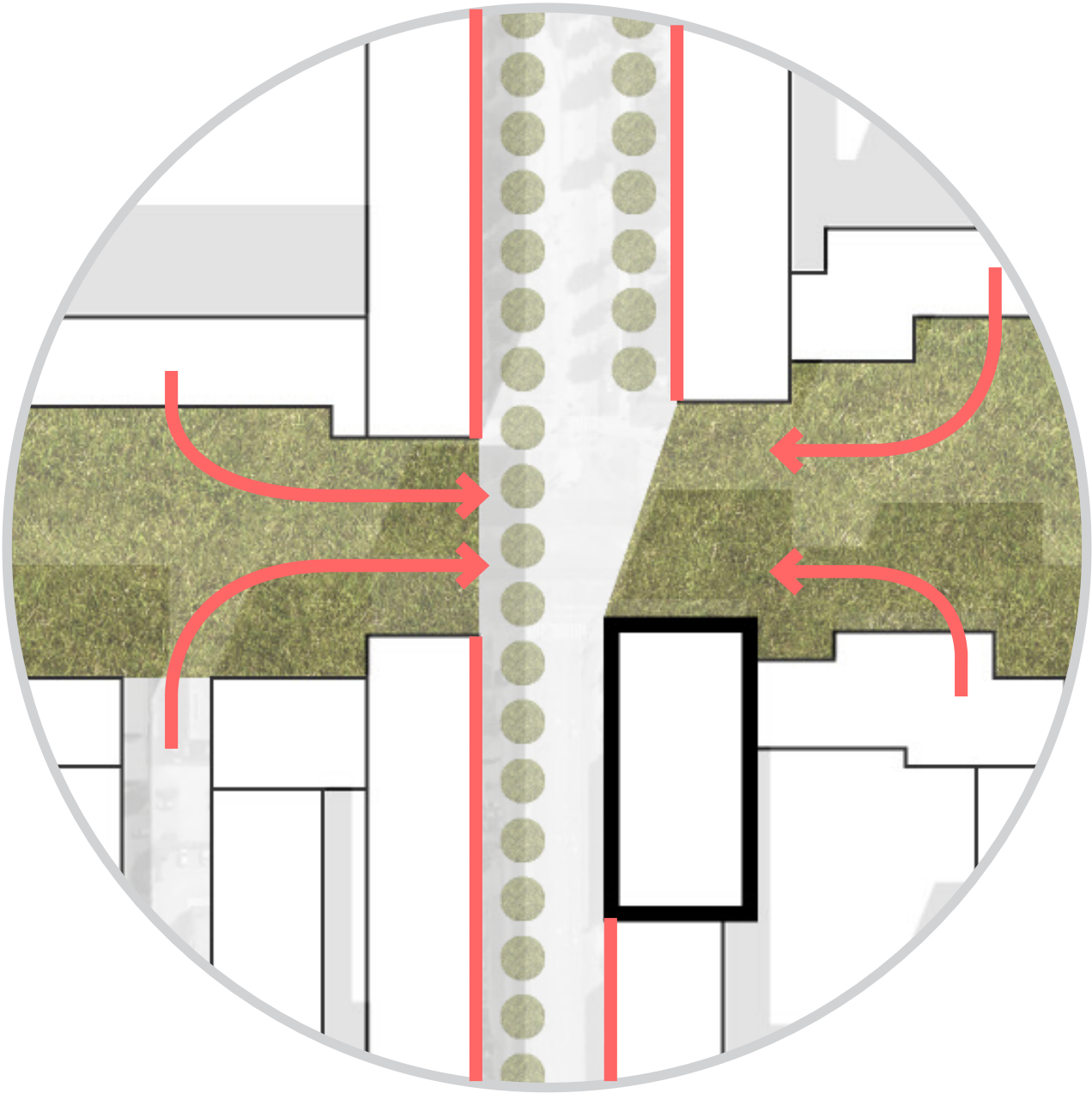

Neighborhood Housing acces

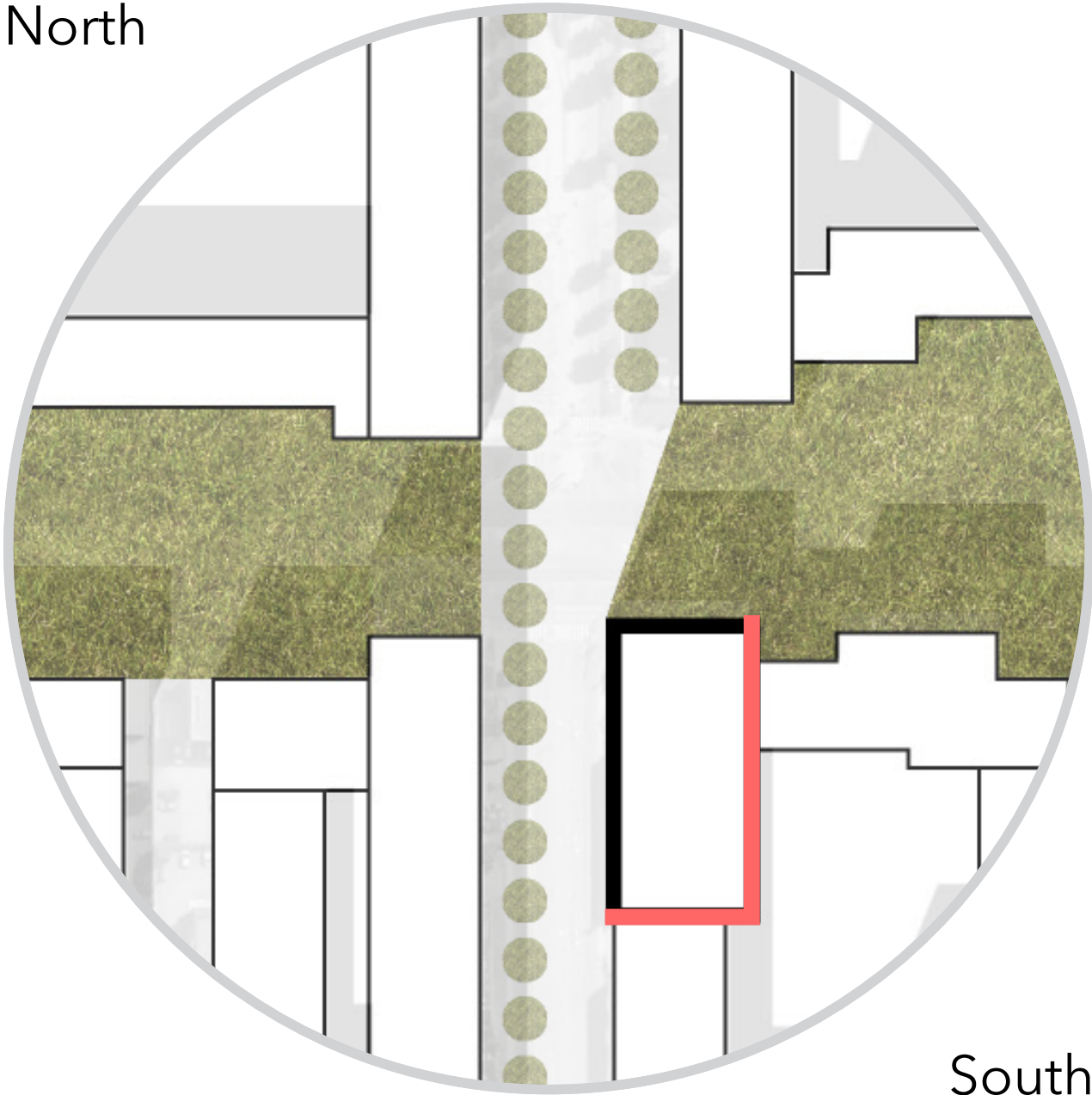

Sun Position



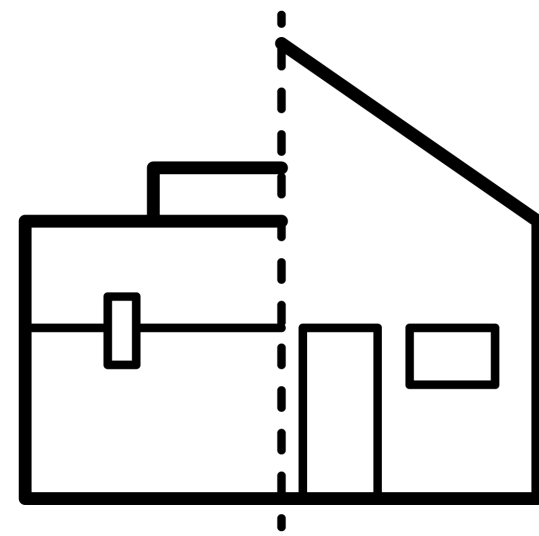

### **TO LIVING AND WORKING**

Still a clear working environment.  
Same amount of m<sup>2</sup> Office space.  
FSI from 0.8 to 2.3.

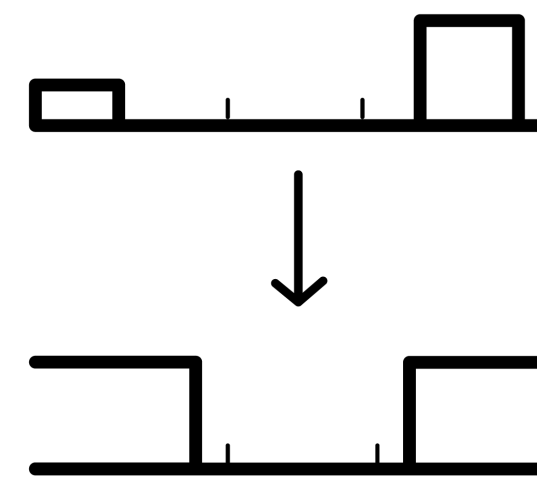

### **CLEAR STREET PROFILE**

Human Scale.  
Addition of function to create streets.  
Removal of parking.

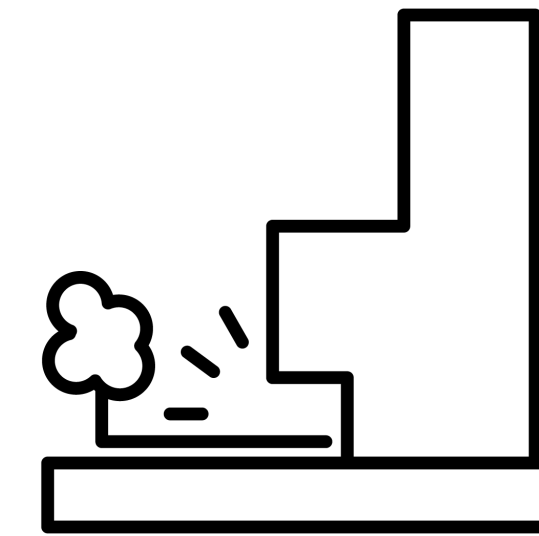

### **SOCIAL POINTS**

Shopping.  
Bars.  
Recreational.





**UPCYCLE AMSTEL**

Amstel III  
re-cycle, re-use  
Waste & Up-cycle  
Design for Disassembly.



**RESEARCH**

Case Study  
Material Potential



**URBAN PLAN**

Amstel III  
Main street  
Park

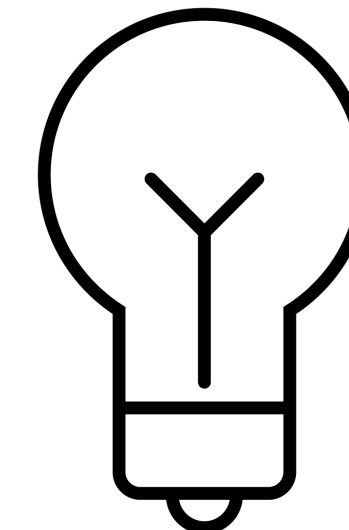

**CONCEPT**

Cultural Meeting spot.  
Circular Demonstrator.  
Innovation hub.

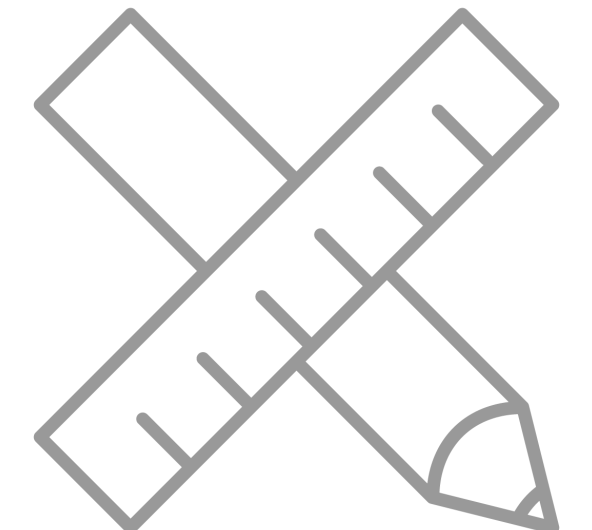

**DESIGN**

Program  
Volume study.



# PROBLEM STATEMENT



## **NEW IDENTITY**

Transition to Mixed Urban City.  
Increased density  
136 --> 30.000 Inhabitants.

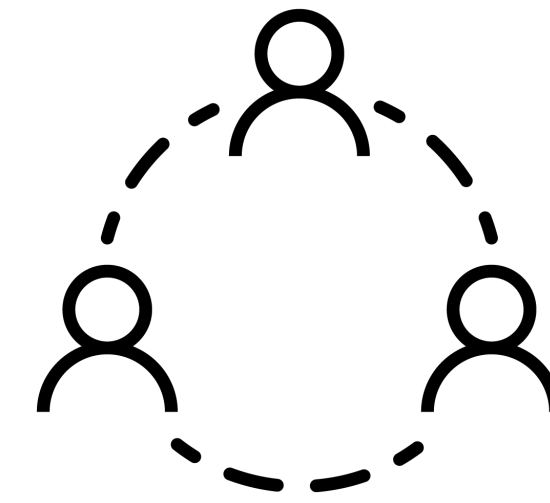

## **SOCIAL CONNECION**

Need for Social interaction.  
Spot to come together  
Knowledge Sharing.



# MEET

Casually  
Drop by and Hang out.



# MEET

Casually  
Drop by and Hang out.

# LEARN

Through Shared Interests.  
Community driven.  
Social Workshops.  
Sports Classes.



## **MEET**

Casually  
Drop by and Hang out.

## **LEARN**

Through Shared Interests.  
Community driven.  
Social Workshops.  
Sports Classes.

## **DEVELOP**

Through Working experiences.  
Develop a bond that's knowledge  
driven

## **MEET**

Casually  
Drop by and Hang out.

### **CAFE**

Seating area  
Kitchen  
Bar  
Toilets.

## **LEARN**

Through Shared Interests.  
Community driven.  
Social Workshops.  
Sports Classes.

### **AUDITORIUM**

#### **RENTABLE SPACE**

Rentable rooms  
Classroom/ multifunctional hall.

## **DEVELOP**

Through Working experiences.  
Develop a bond that's knowledge  
driven

### **CO-WORKING AREA**

Meeting rooms.  
Flexible office space.



## MEET

Casually  
Drop by and Hang out.

### CAFE

Seating area  
Kitchen  
Bar  
Toilets.

**350 m<sup>2</sup>**

**300 m<sup>2</sup>**

300 m<sup>2</sup>

50 m<sup>2</sup>

## LEARN

Through Shared Interests.  
Community driven.  
Social Workshops.  
Sports Classes.

### AUDITORIUM

### RENTABLE SPACE

Rentable rooms  
Classroom/ multifunctional hall.

**1000 m<sup>2</sup>**

**300 m<sup>2</sup>**

**700 m<sup>2</sup>**

## DEVELOP

Through Working experiences.  
Develop a bond that's knowledge  
driven

### CO-WORKING AREA

Meeting rooms.  
Flexible office space.

**2000 m<sup>2</sup>**

**2000 m<sup>2</sup>**

## MEET

Casually  
Drop by and Hang out.

### CAFE

Seating area  
Kitchen  
Bar  
Toilets.

## LEARN

Through Shared Interests.  
Community driven.  
Social Workshops.  
Sports Classes.

### AUDITORIUM RENTABLE SPACE

Rentable rooms  
Classroom/ multifunctional hall.

## DEVELOP

Through Working experiences.  
Develop a bond that's knowledge  
driven

### CO-WORKING AREA

Meeting rooms.  
Flexible office space.

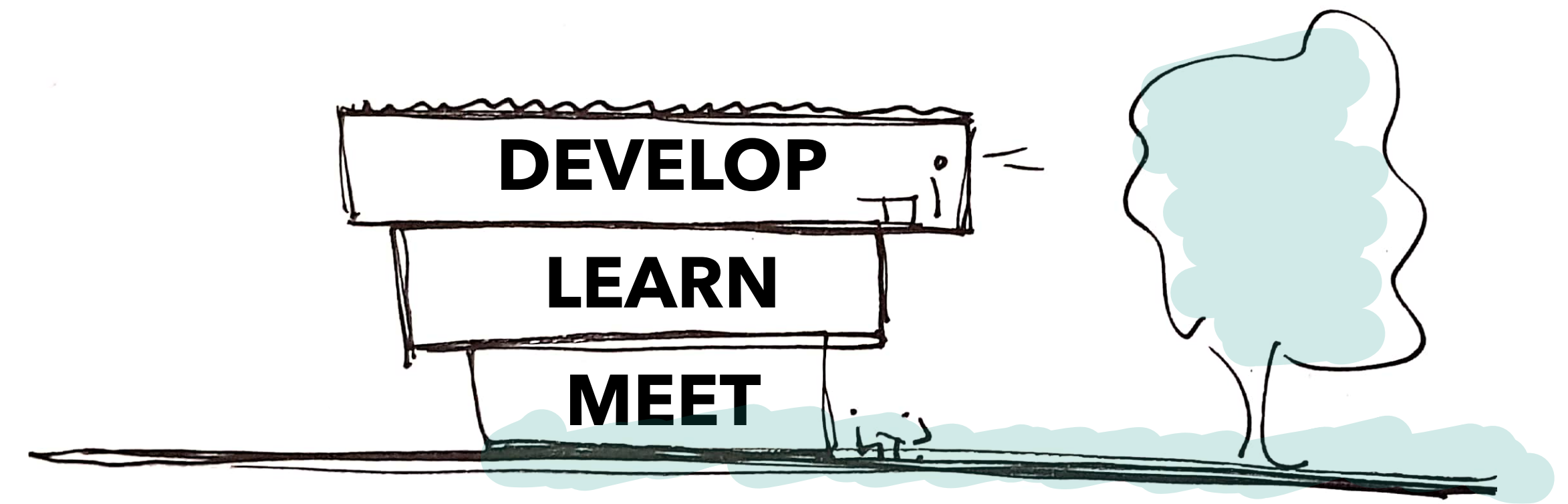



## MEET

Casually  
Drop by and Hang out.

### CAFE

Seating area  
Kitchen  
Bar  
Toilets.



## LEARN

Through Shared Interests.  
Community driven.  
Social Workshops.  
Sports Classes.

### AUDITORIUM

### RENTABLE SPACE

Rentable rooms  
Classroom/ multifunctional hall.

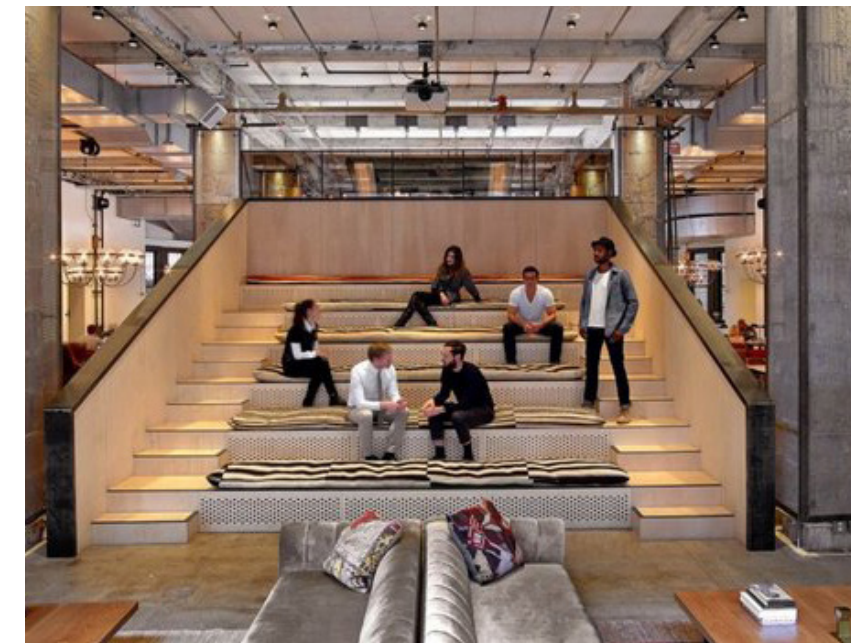

## DEVELOP

Through Working experiences.  
Develop a bond that's knowledge driven

### CO-WORKING AREA

Meeting rooms.  
Flexible office space.





# CONCEPT : CONCLUSIONS

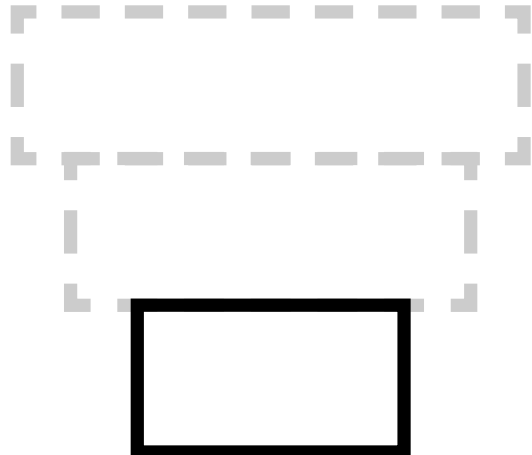

**MEET**

Drop by and Hang out.

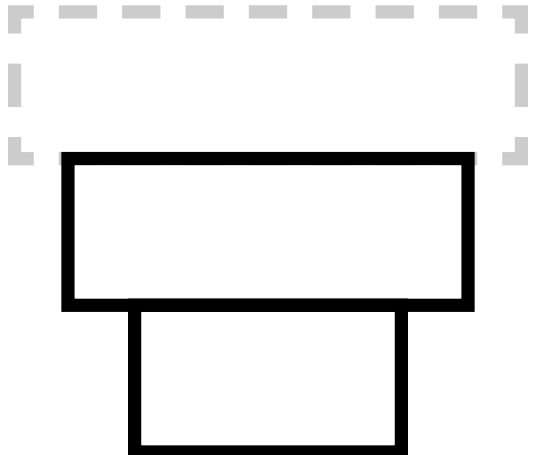

**LEARN**

Through Shared Interests.

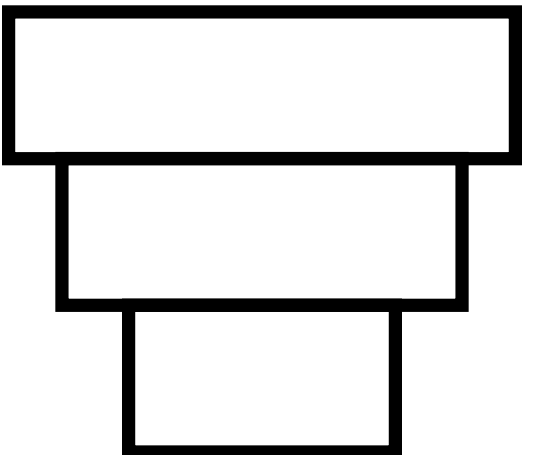

**DEVELOP**

Through working Experiences



# CONCEPT : CONCLUSIONS

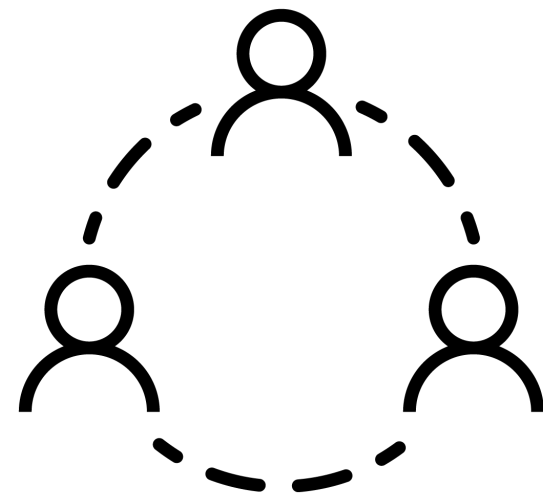

## **INTEGRATE CULTURE**

Merge Work, Culture and living.  
New beating social heart  
of the neighborhood.



## **MEETING POINT**

Cultural meeting point for locals.  
- Meet  
- Share Knowledge  
- Do hobby's.

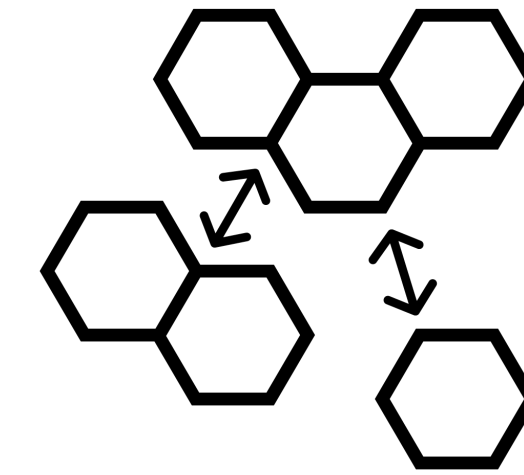

## **DEMONSTRATE CIRCULARITY**

Design for disassembly.  
Learn from eachother.  
Awareness.  
Adaptable to changing Culture.



**UPCYCLE AMSTEL**

Amstel III  
re-cycle, re-use  
Waste & Up-cycle  
Design for Disassembly.



**RESEARCH**

Case Study  
Material Potential



**URBAN PLAN**

Amstel III  
Main street  
Park

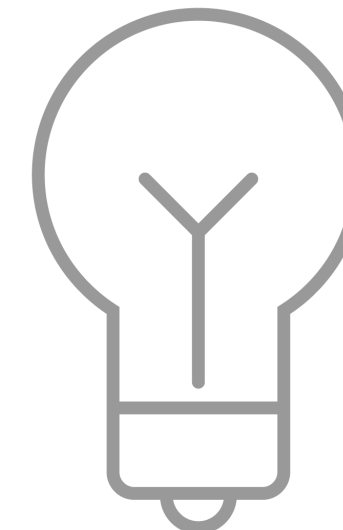

**CONCEPT**

Cultural Meeting spot.  
Circular Demonstrator.  
Innovation hub.

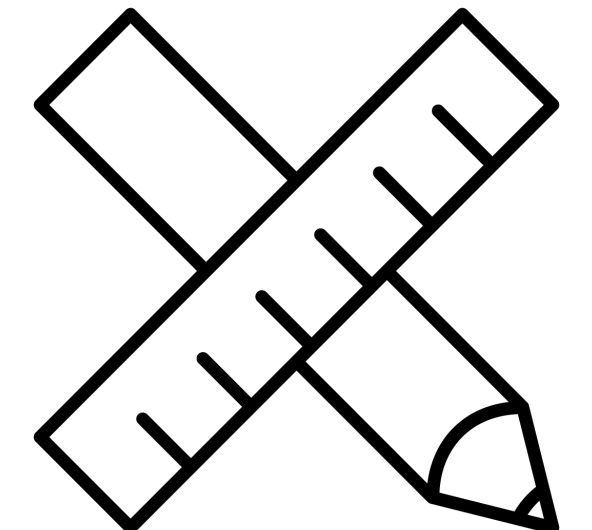

**DESIGN**

Program  
Volume study.



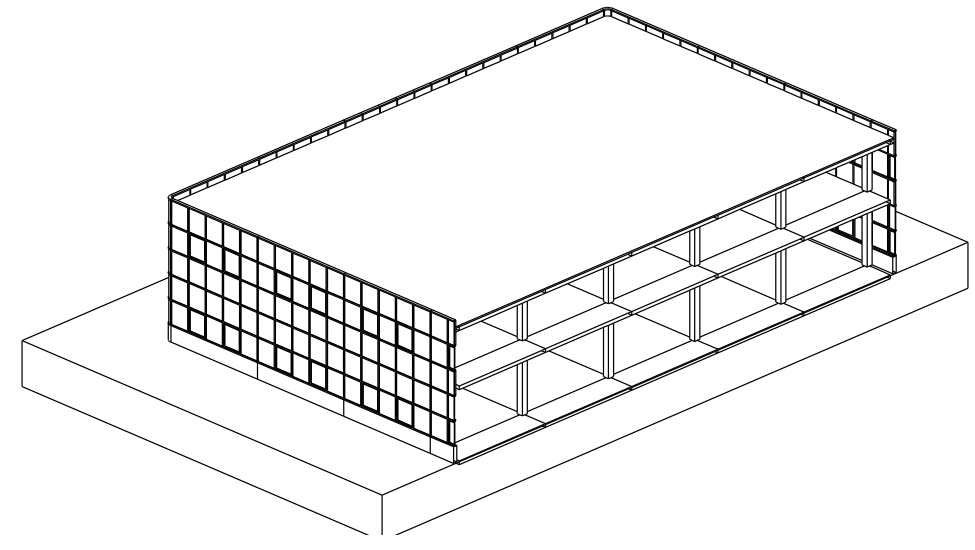

**1986 BUILDING**

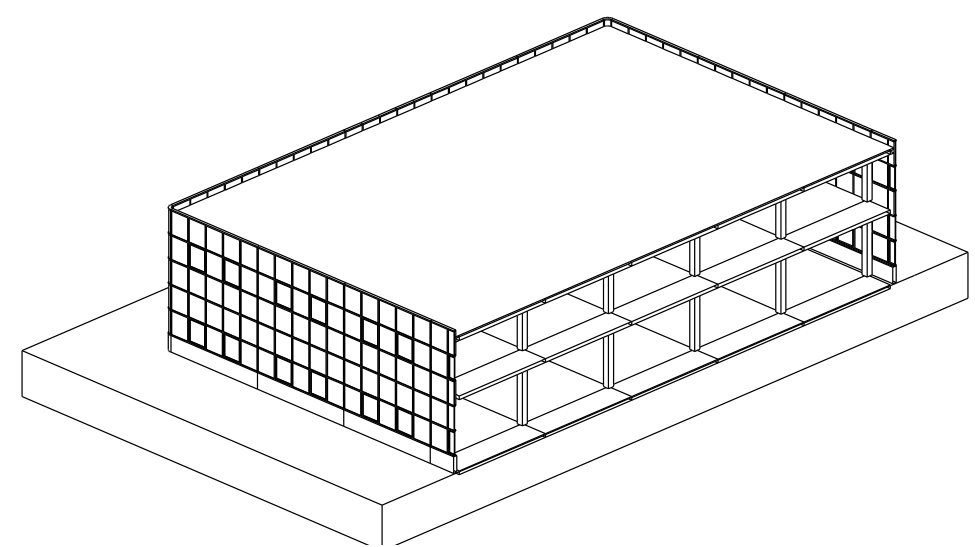

**1986 BUILDING**

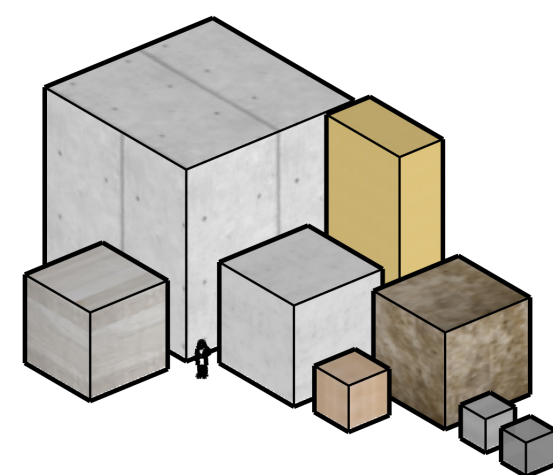

**MATERIAL STOCK**



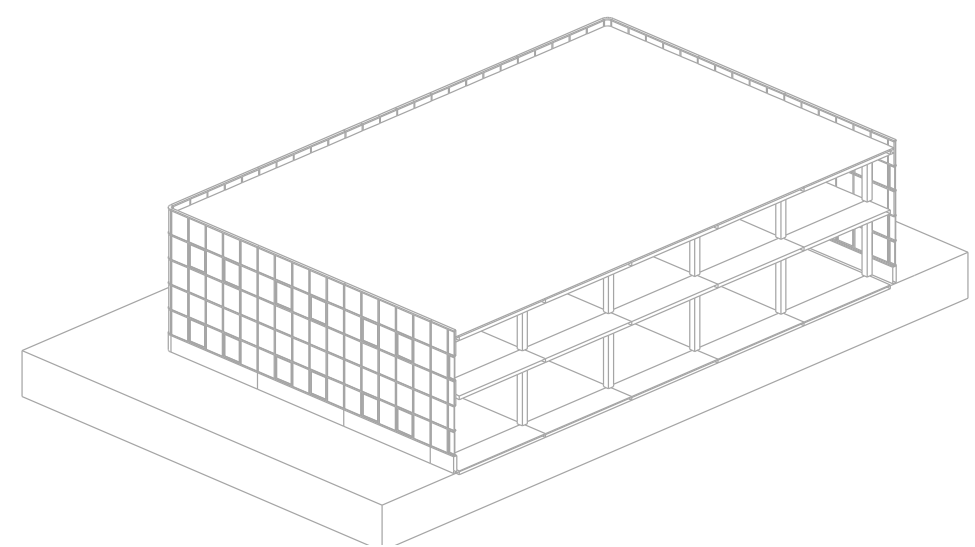

**1986 BUILDING**

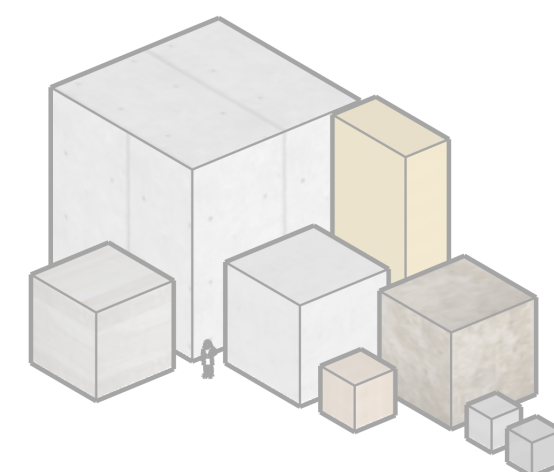

**MATERIAL STOCK**

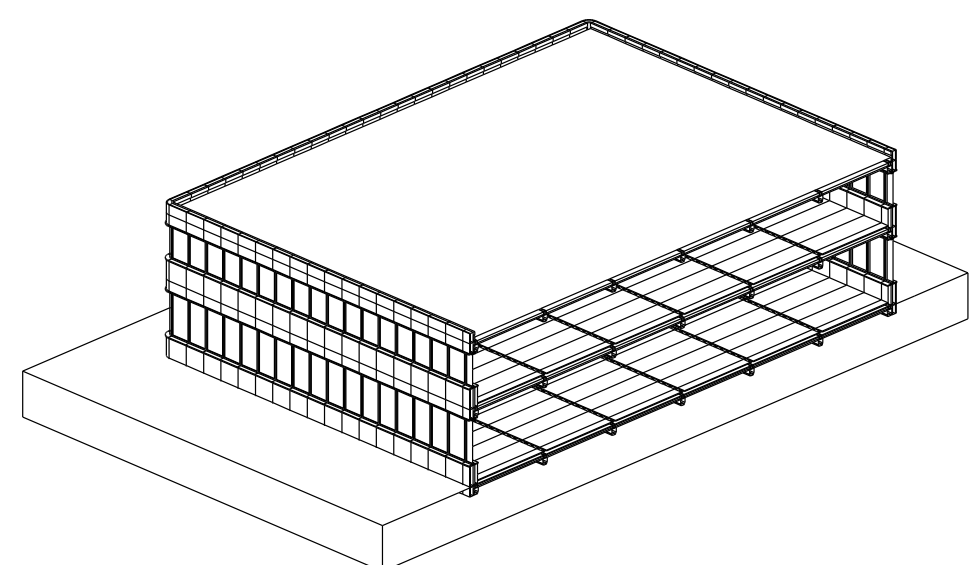

**2018 CIRCLE BUILDING**

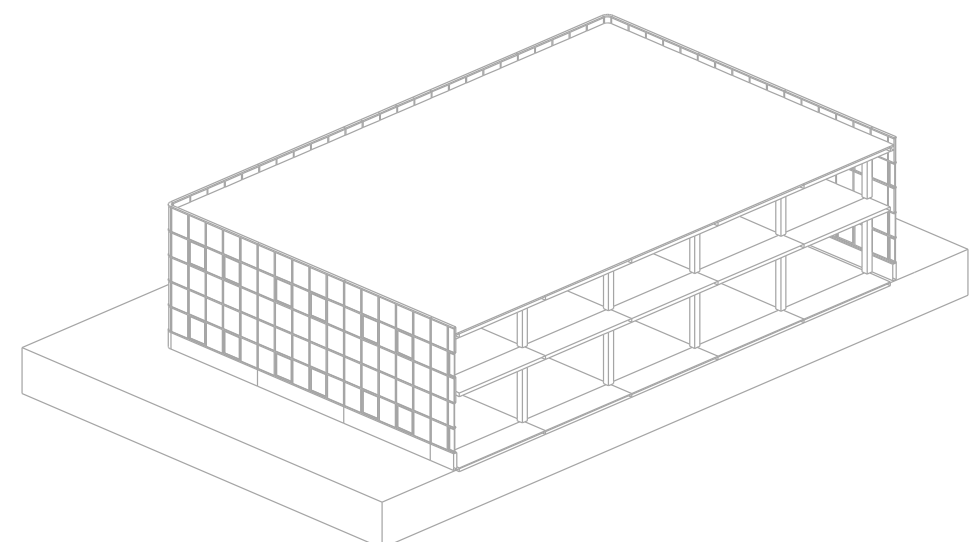

**1986 BUILDING**

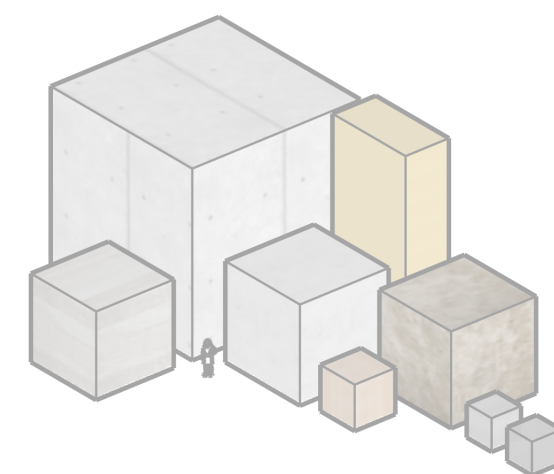

**MATERIAL STOCK**

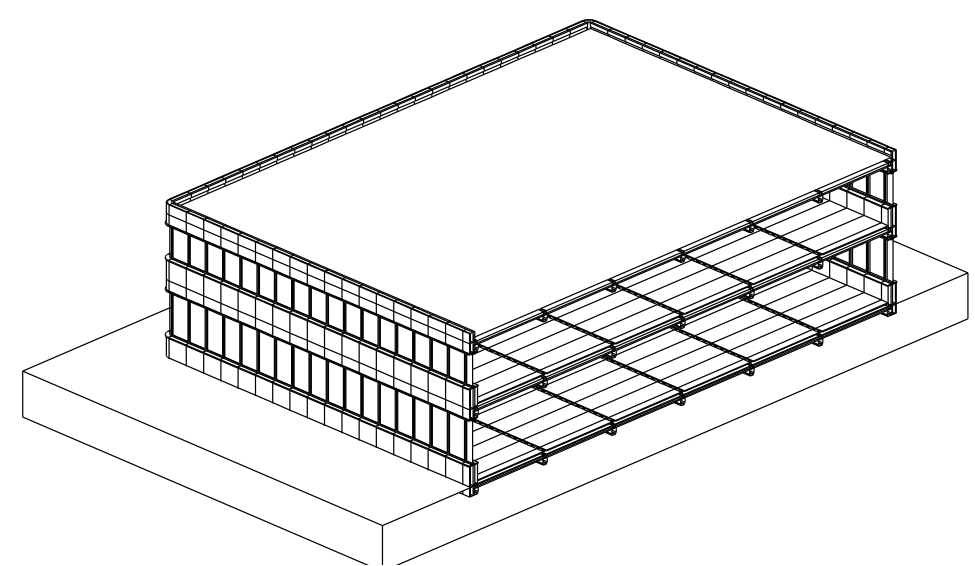

**2018 CIRCLE BUILDING**

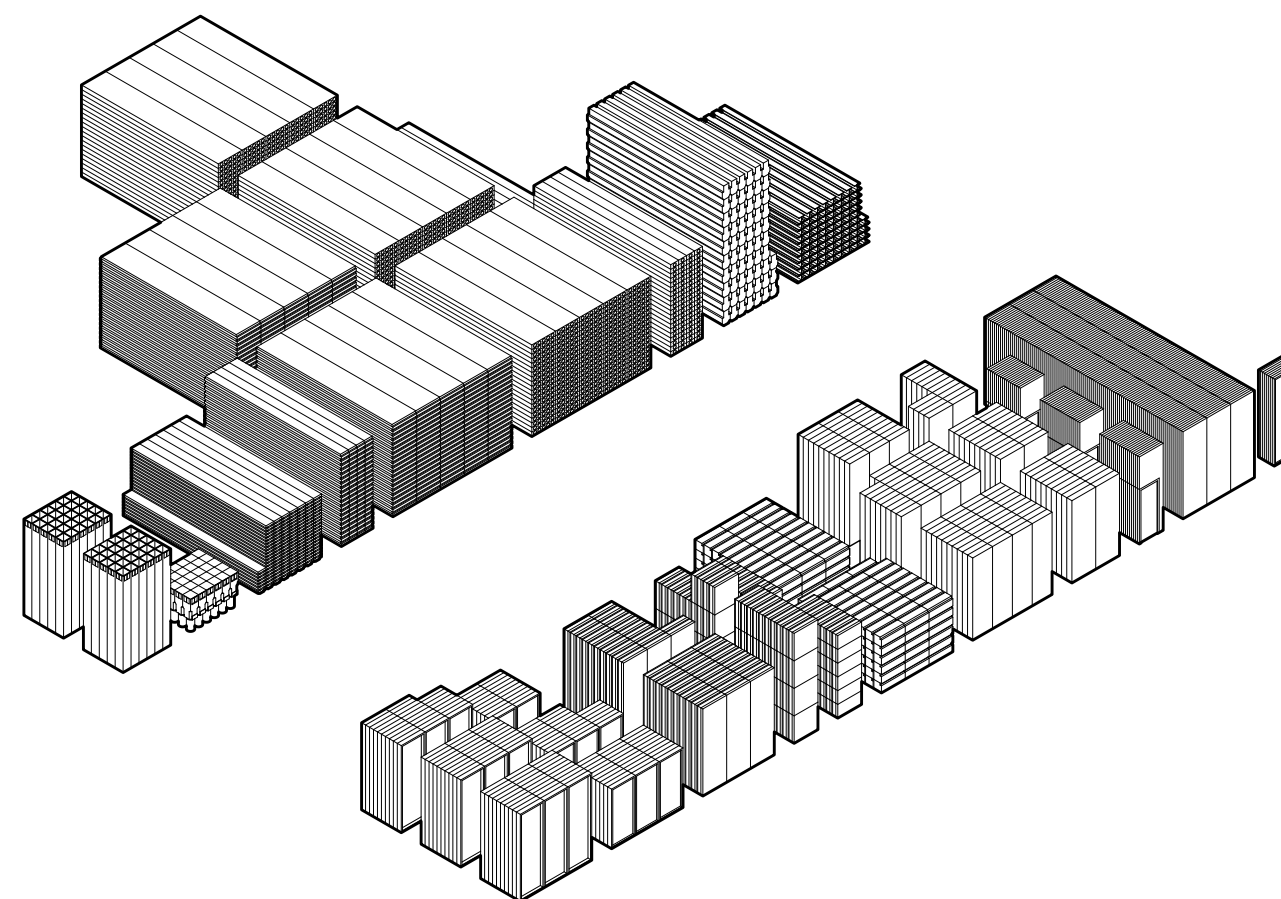

**COMPONENT STOCK**



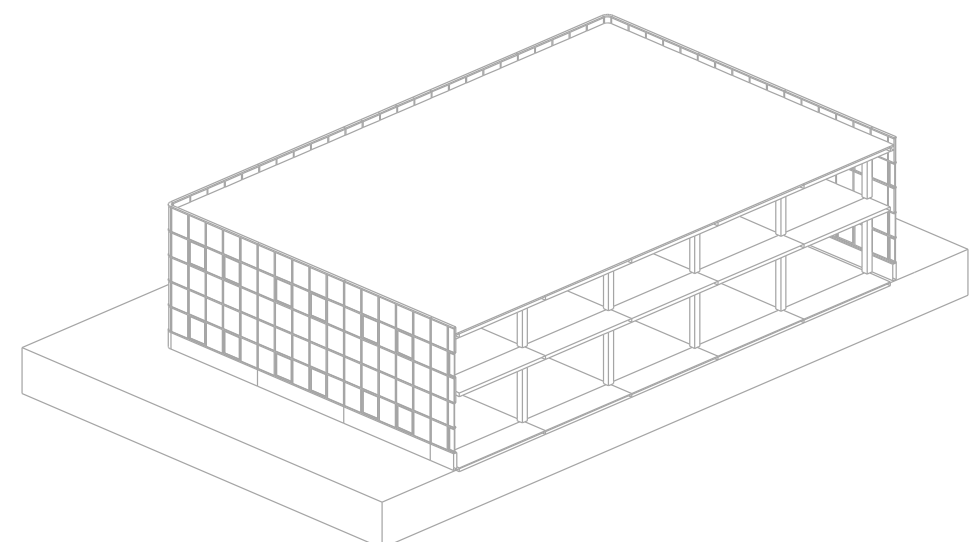

**1986 BUILDING**

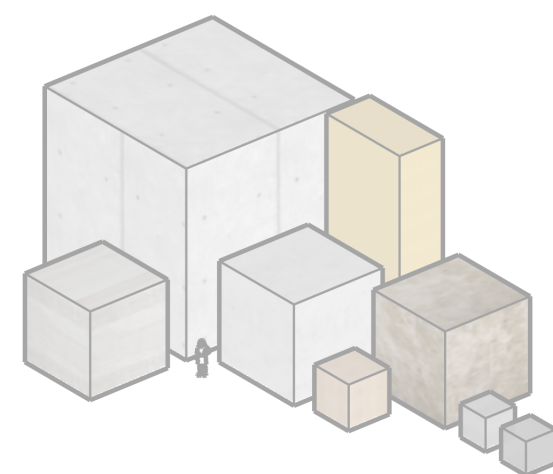

**MATERIAL STOCK**

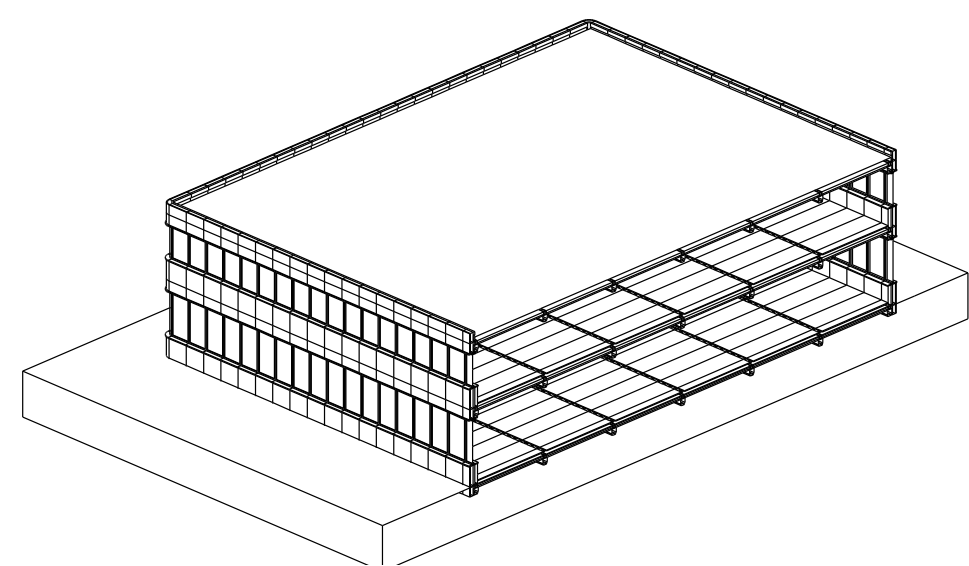

**2018 CIRCLE BUILDING**

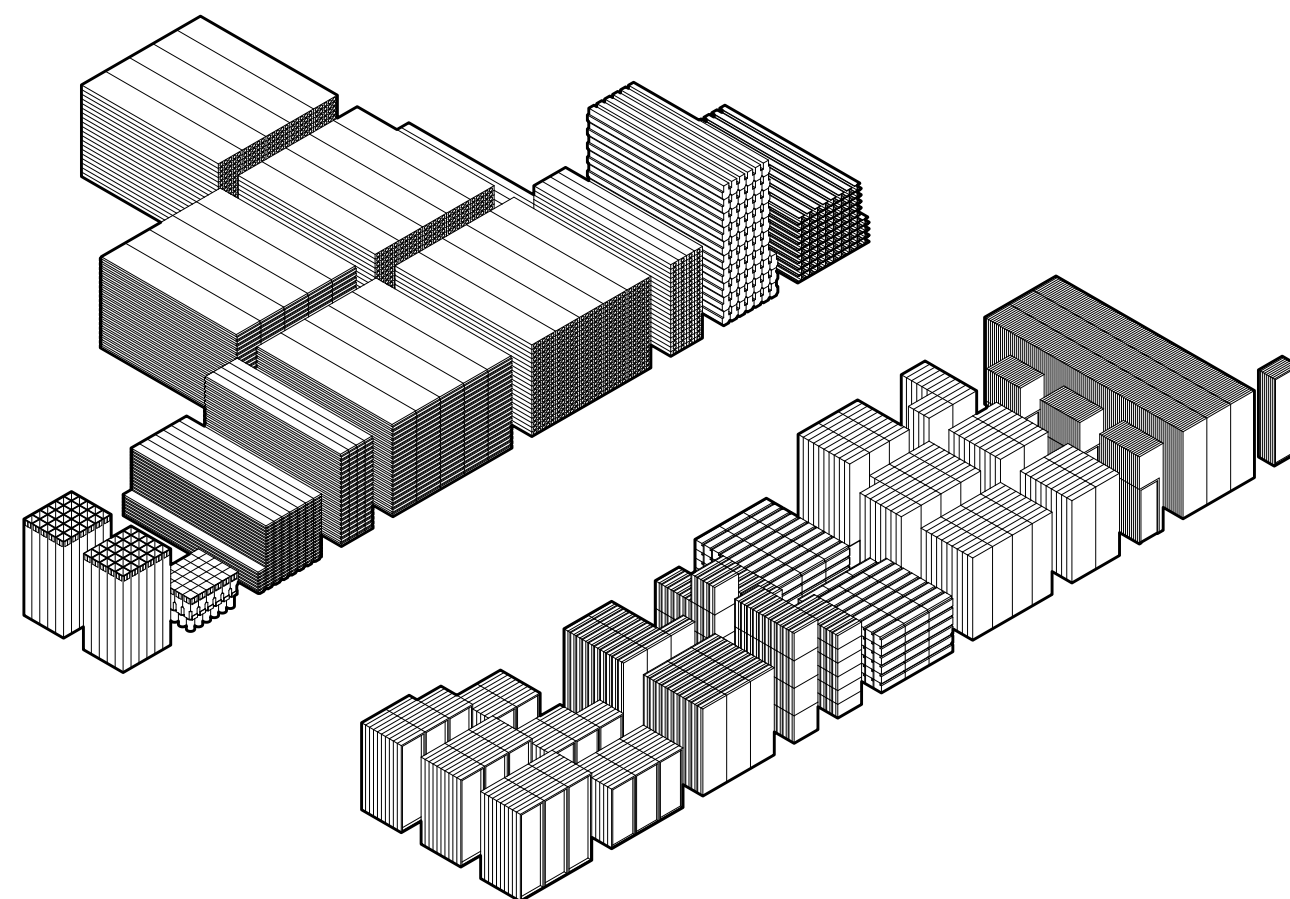

**COMPONENT STOCK**

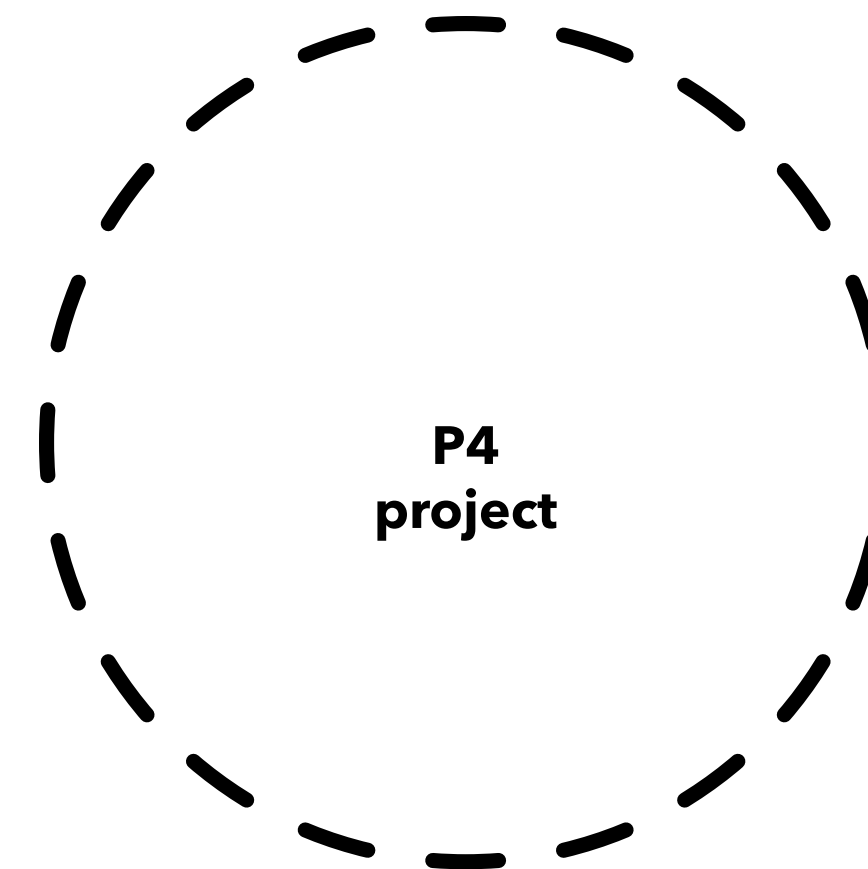

**P4 SOCIAL HUB**

# **The Cultural Social hub.**



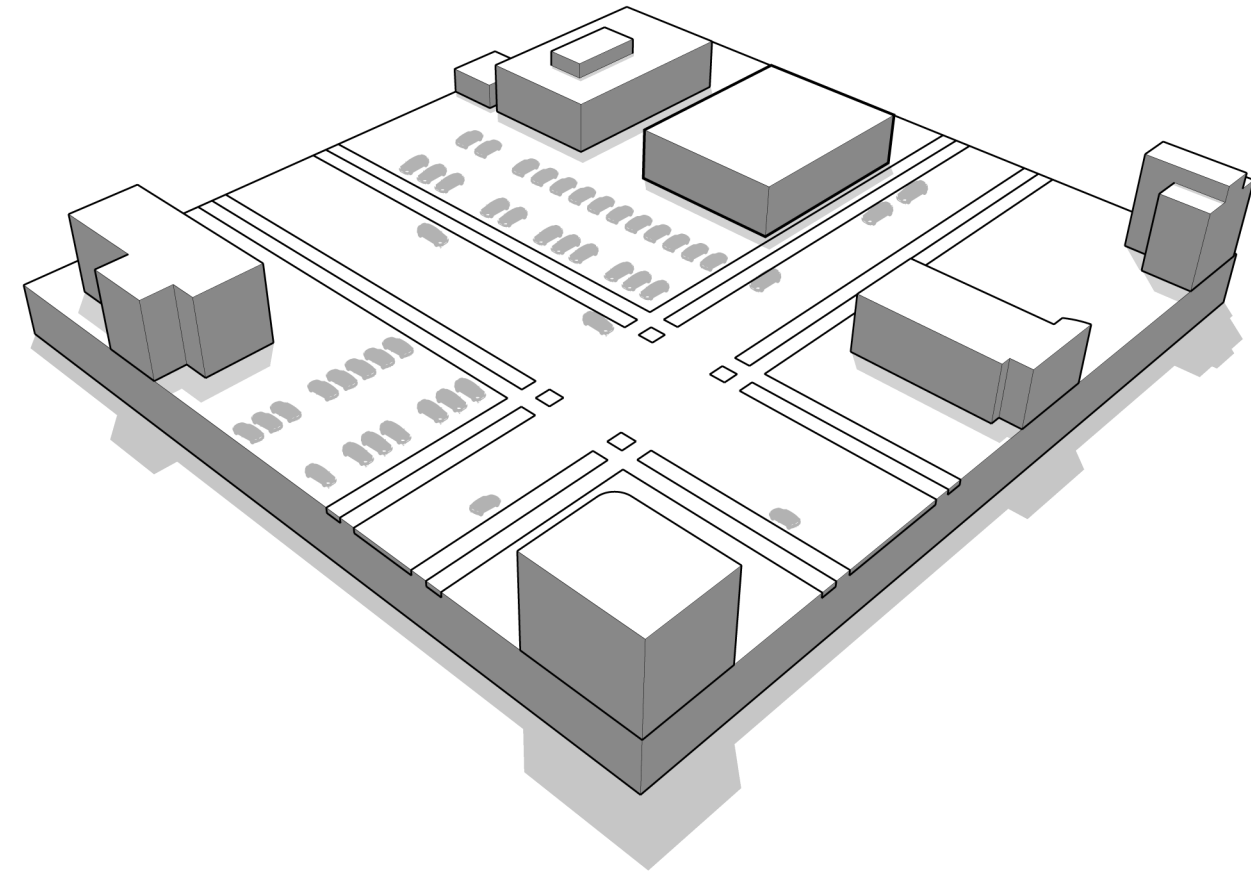

Phase 1: The old Building

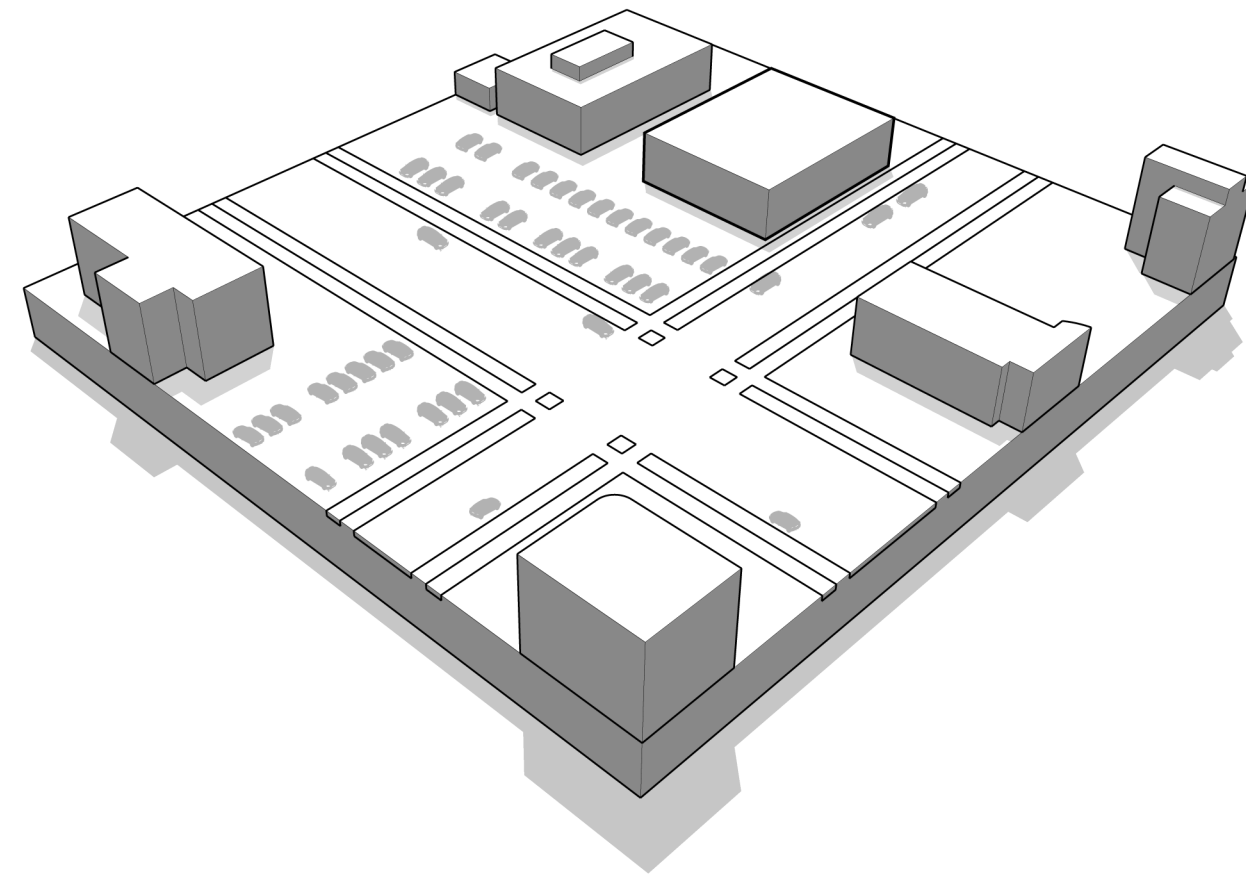

Phase 1: The old Building

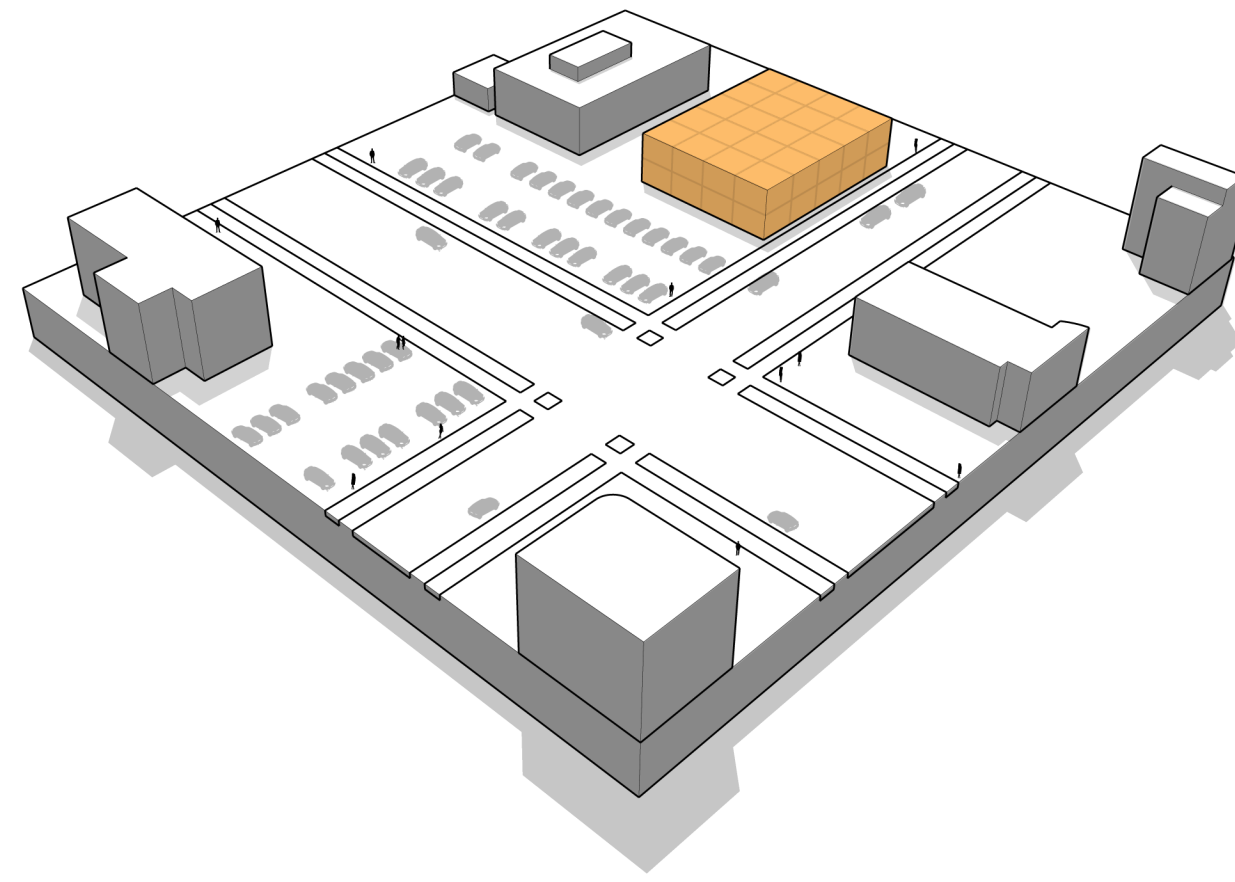

Phase 2: The Circle Building



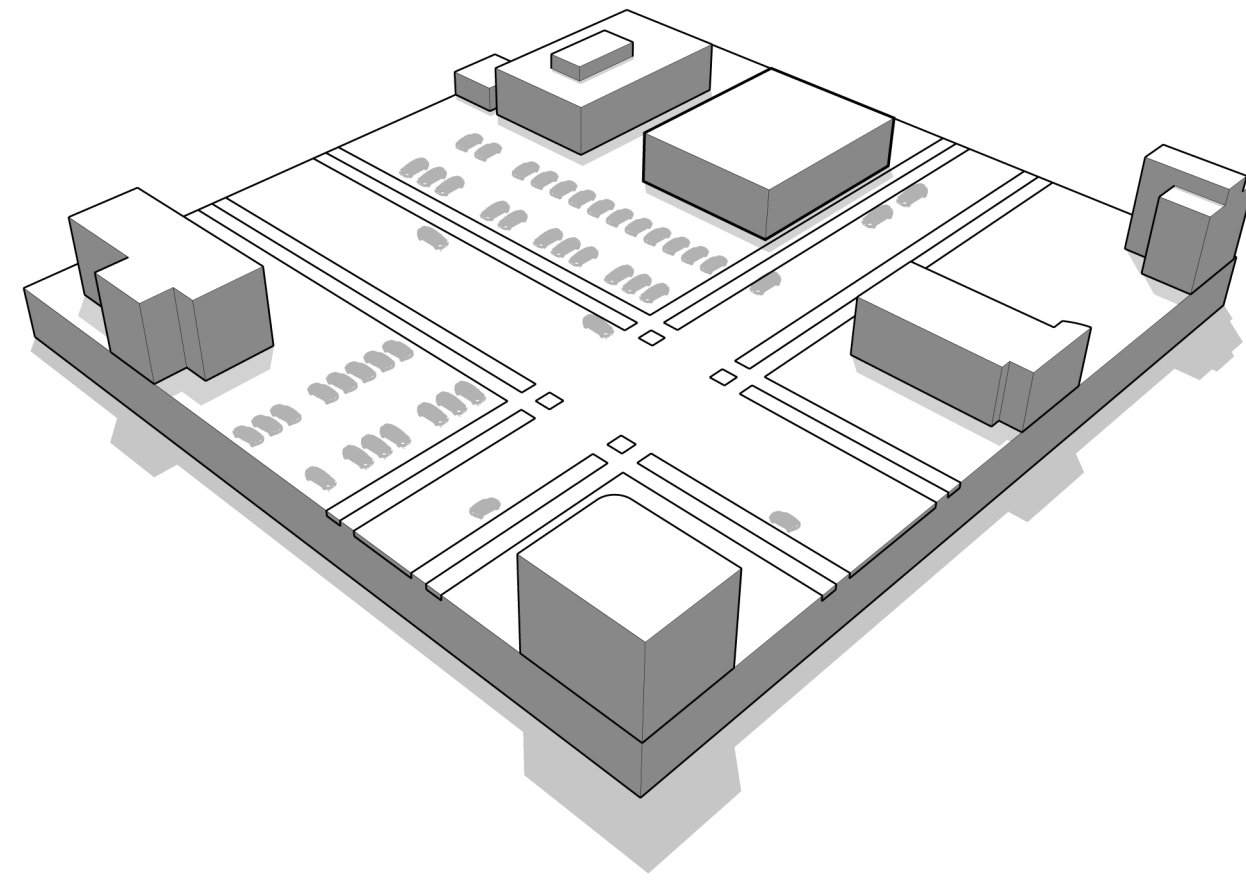

Phase 1: The old Building

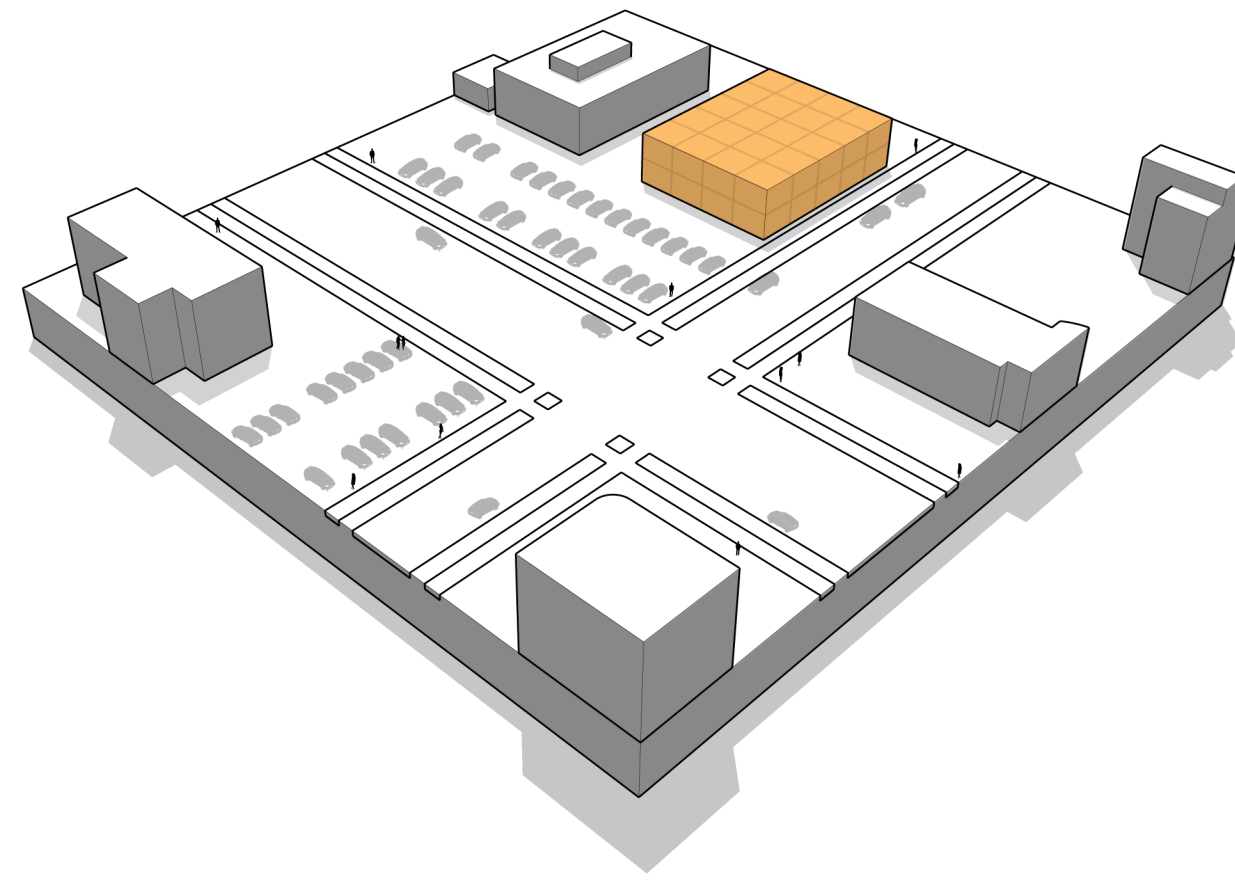

Phase 2: The Circle Building

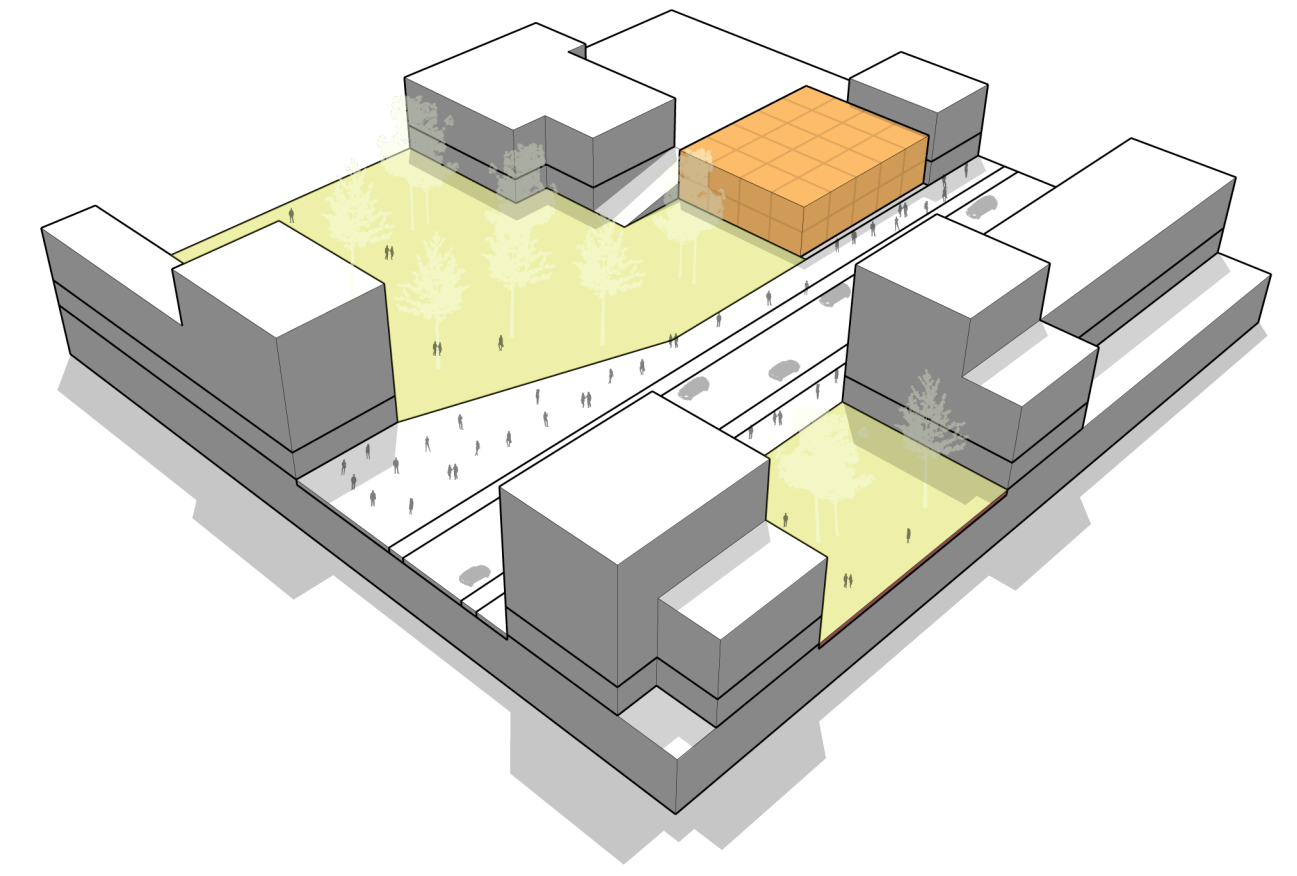

Area Development 2030

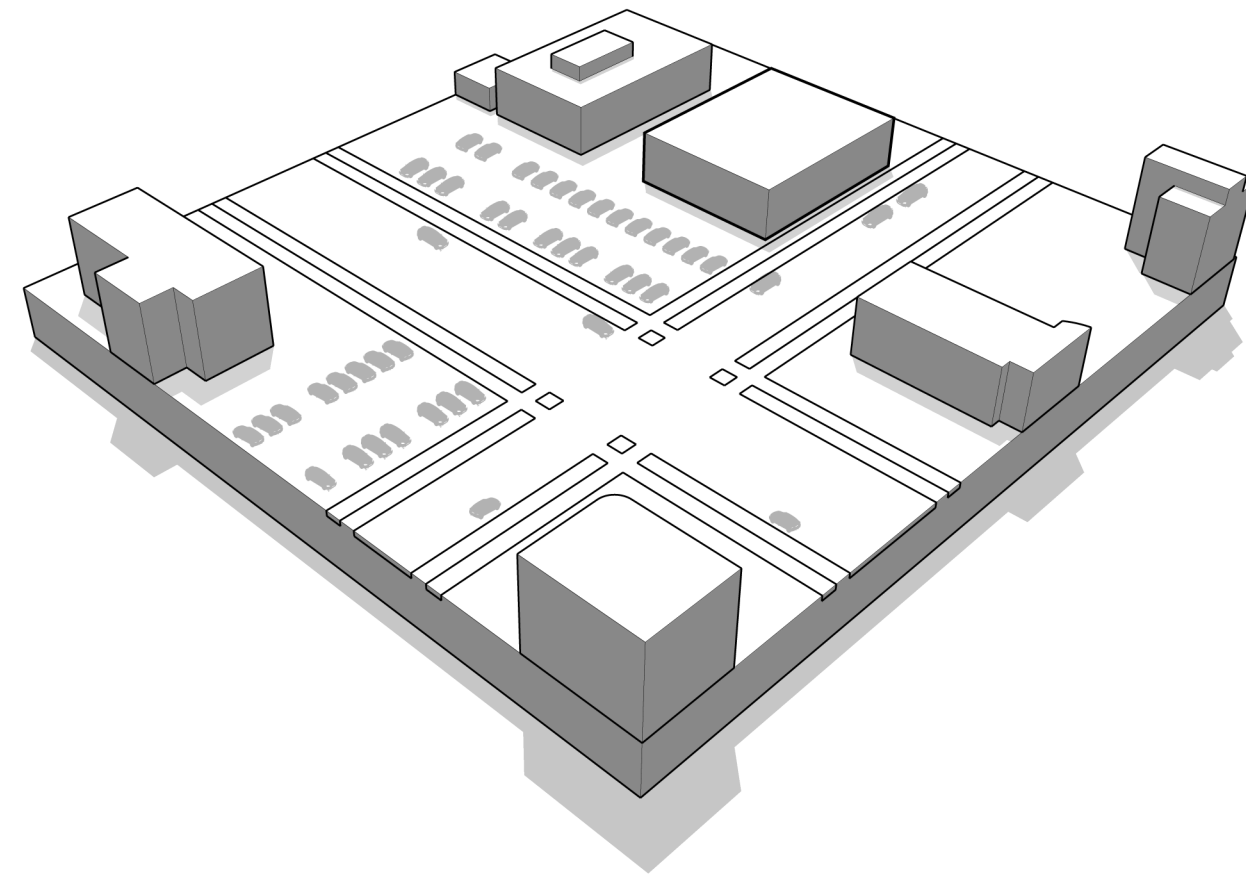

Phase 1: The old Building

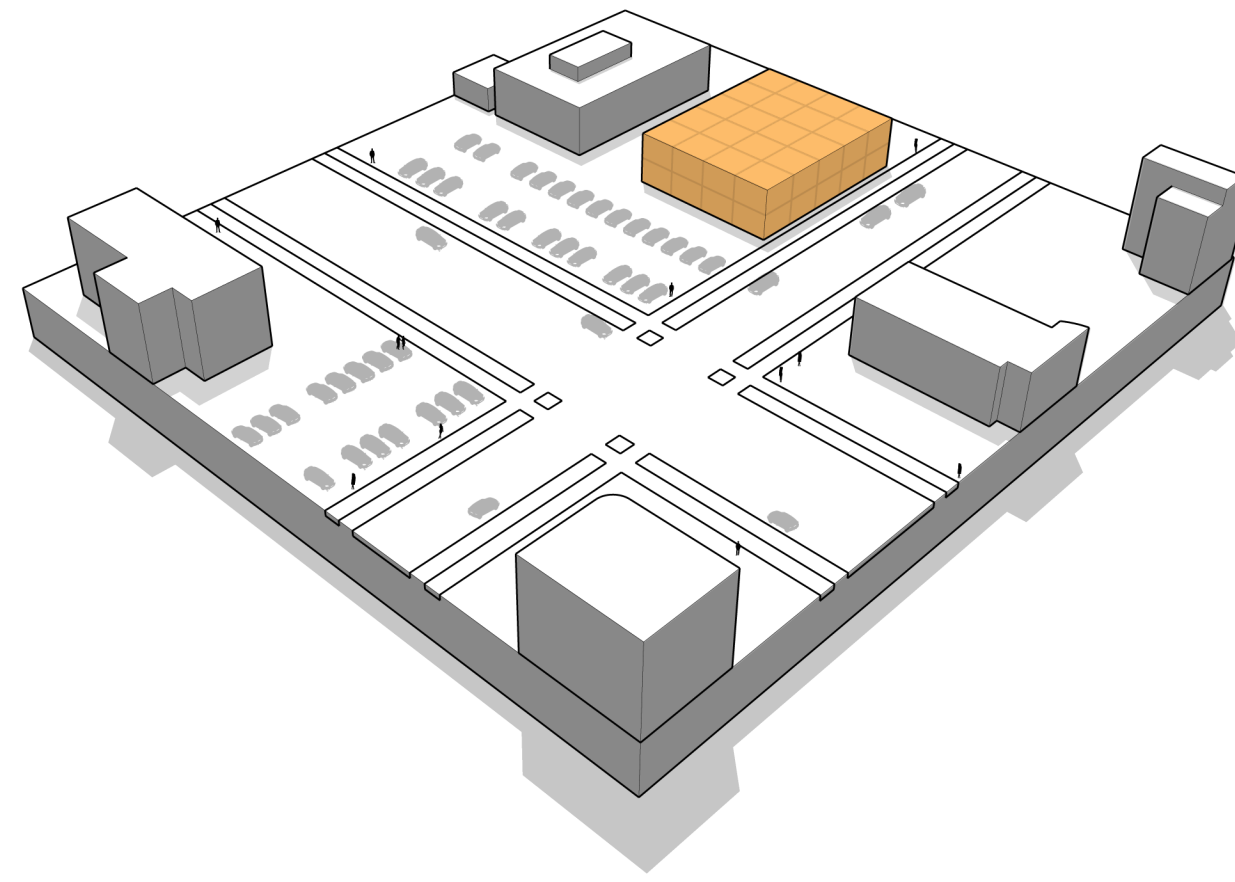

Phase 2: The Circle Building

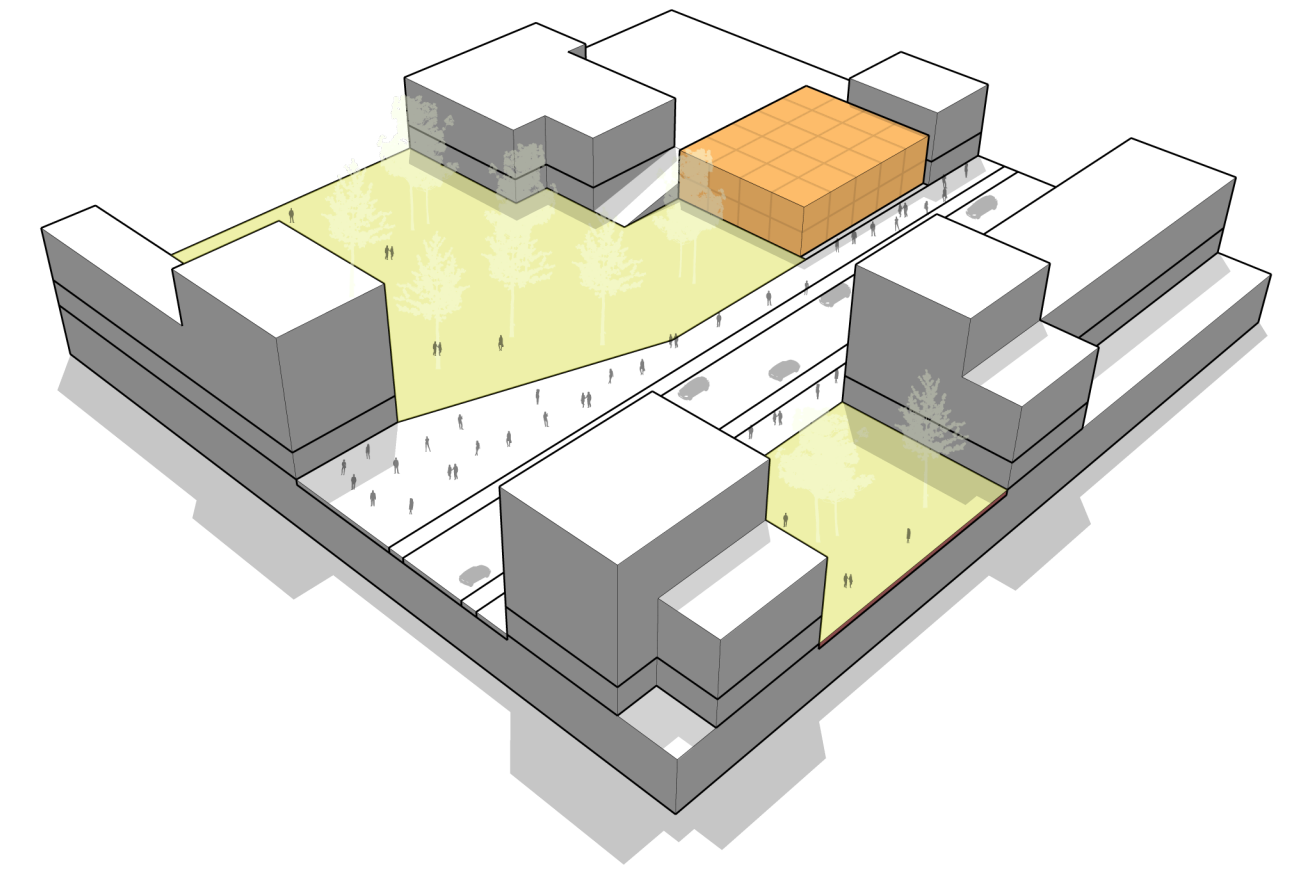

Area Development 2030

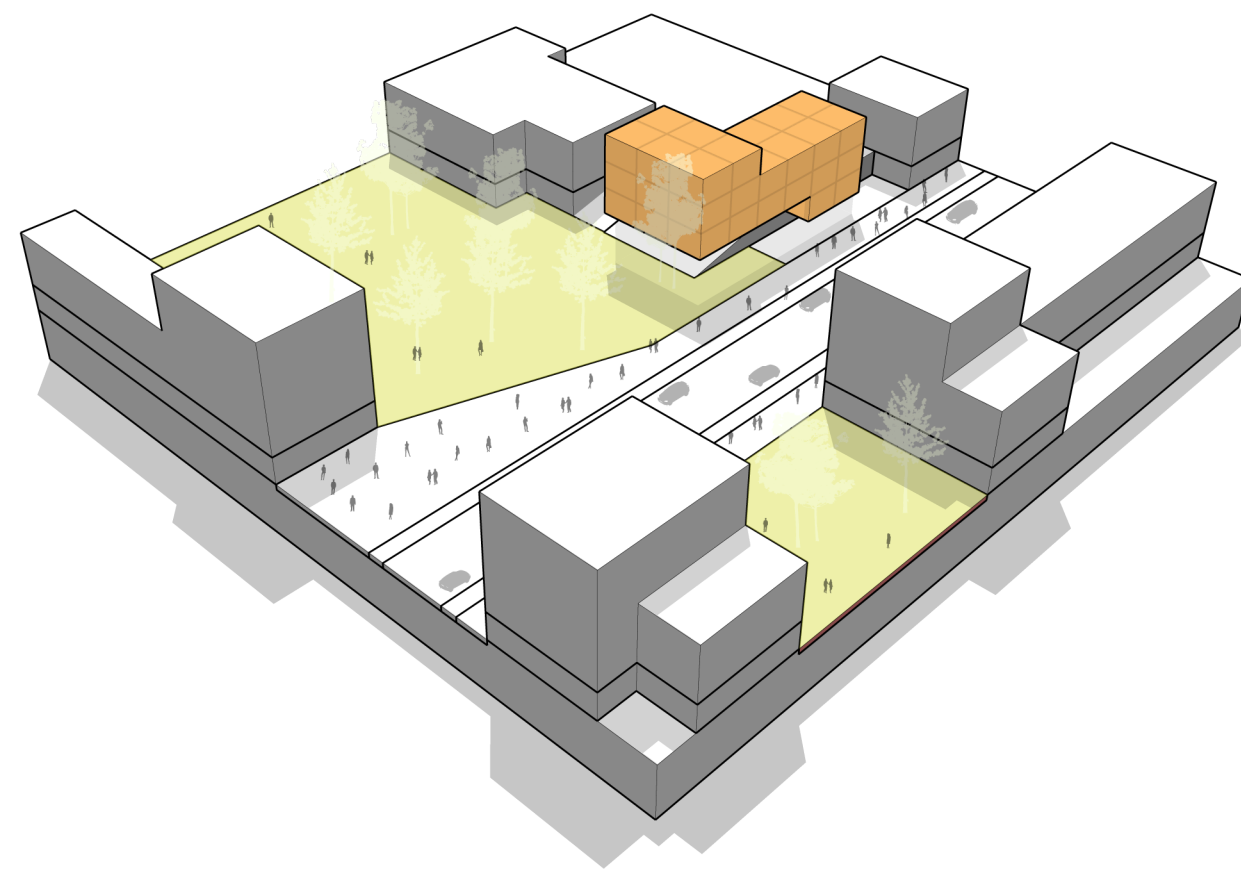

Phase 3: The Circle Community Building  
The Development Area



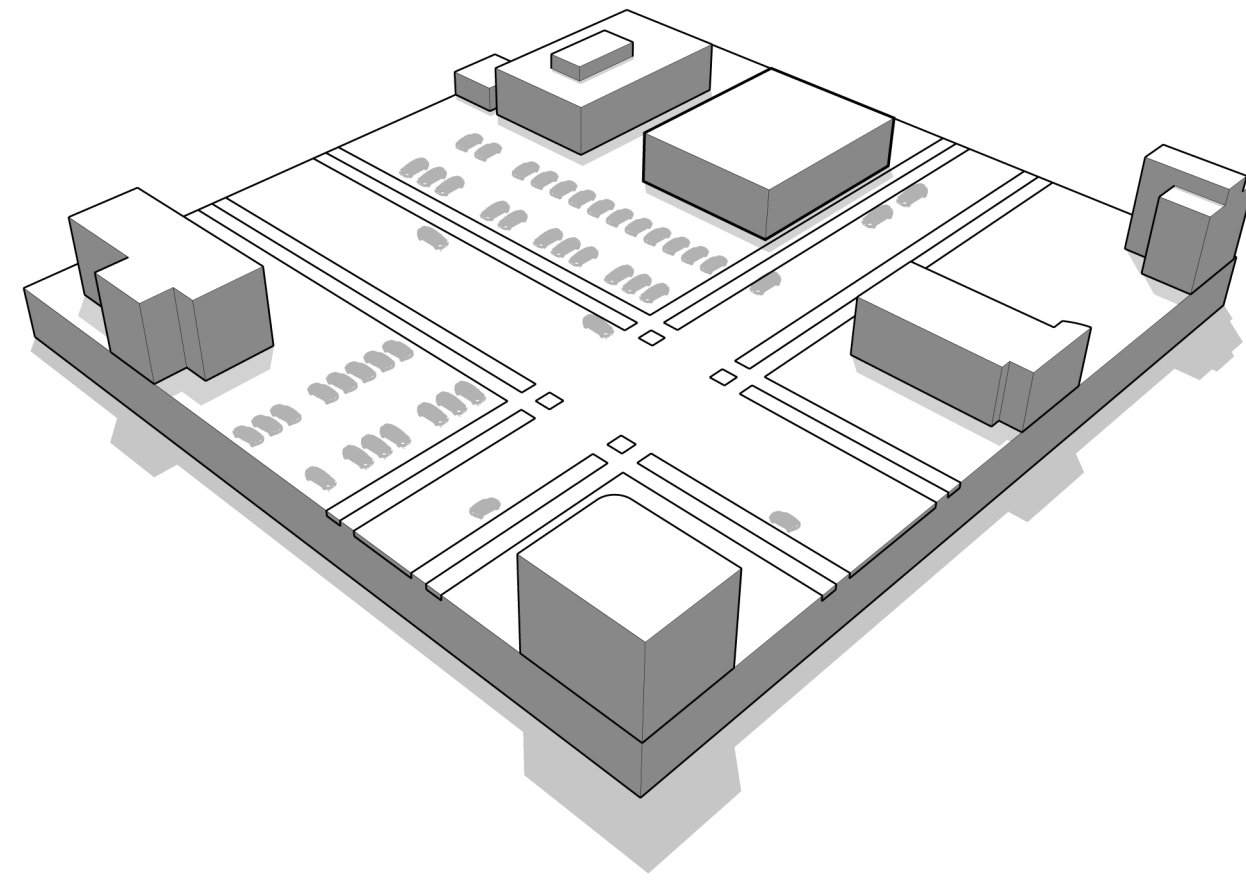

Phase 1: The old Building

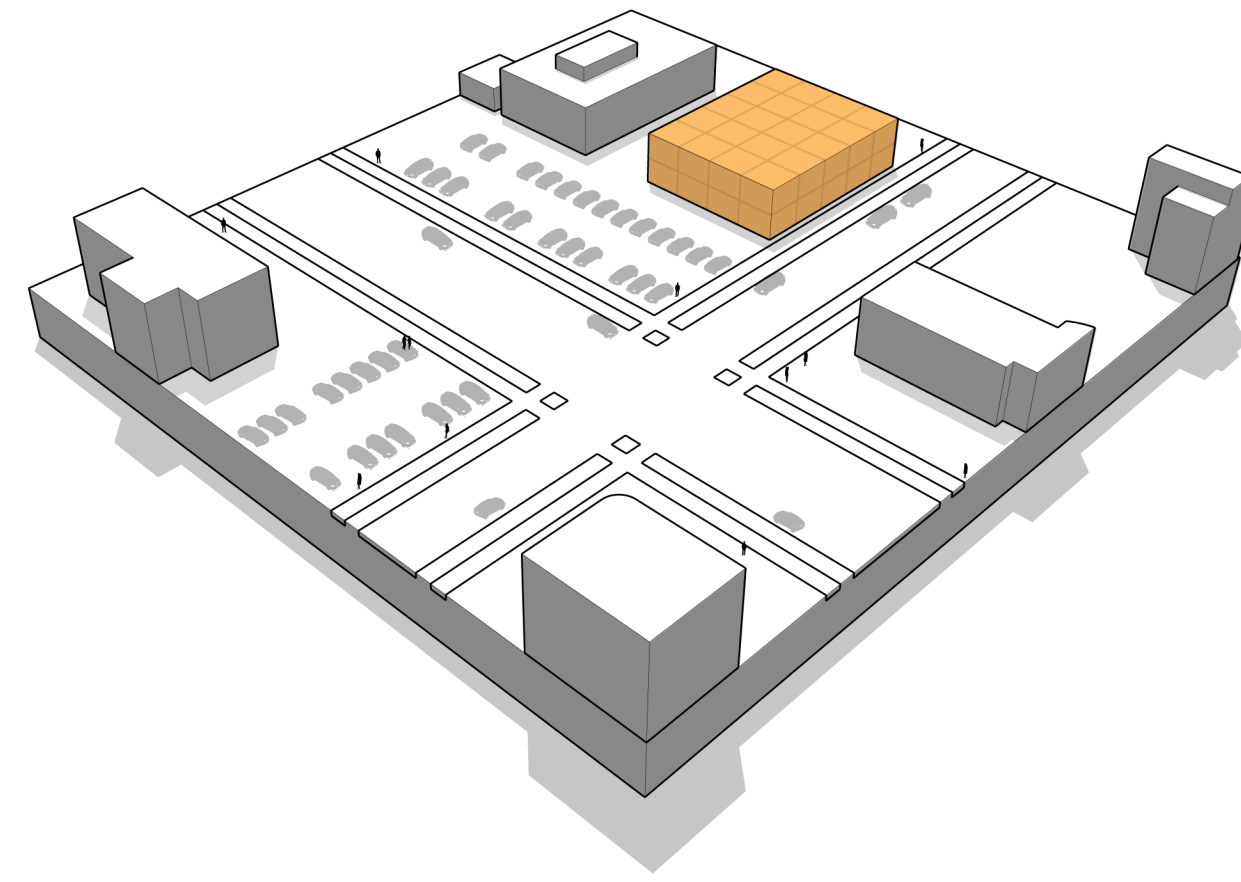

Phase 2: The Circle Building

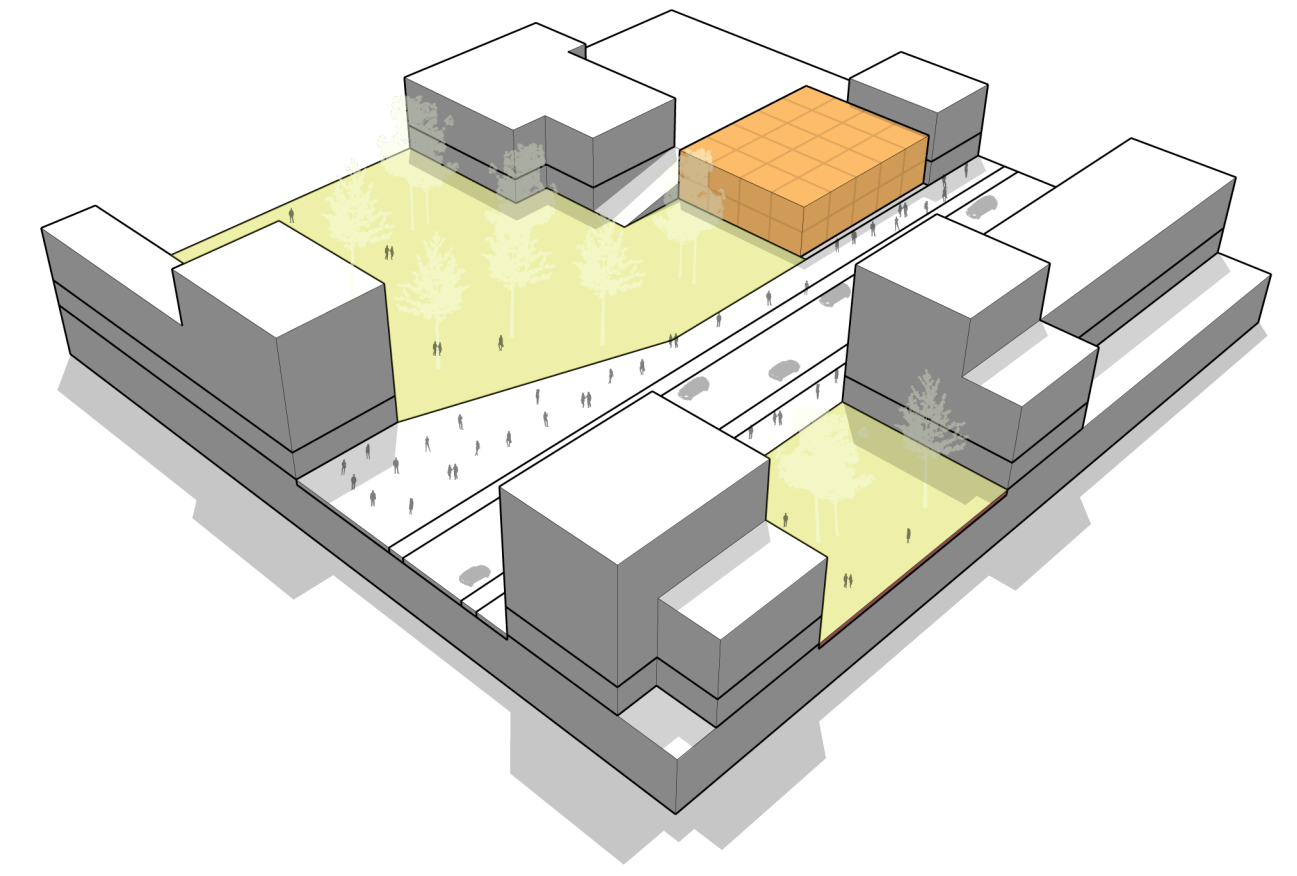

Area Development 2030

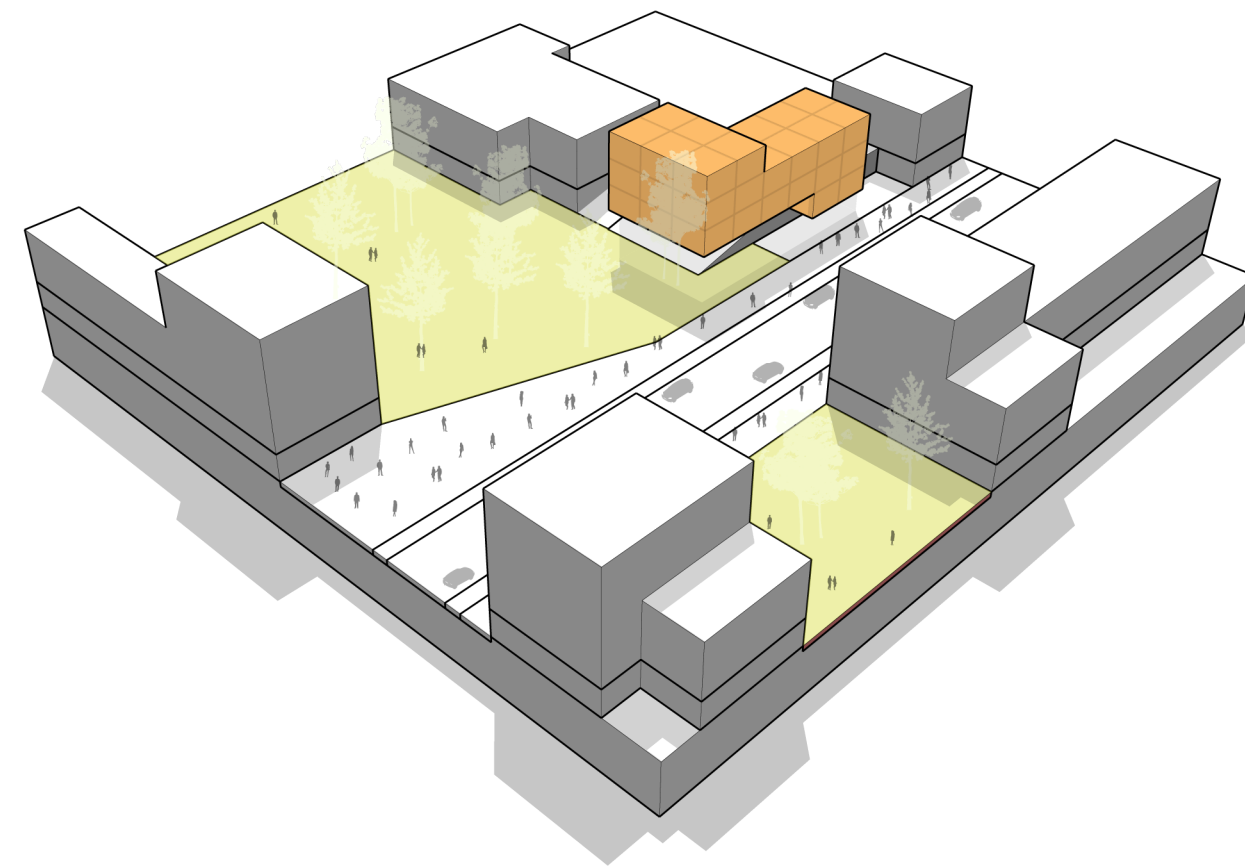

Phase 3: The Circle Community Building  
The Development Area

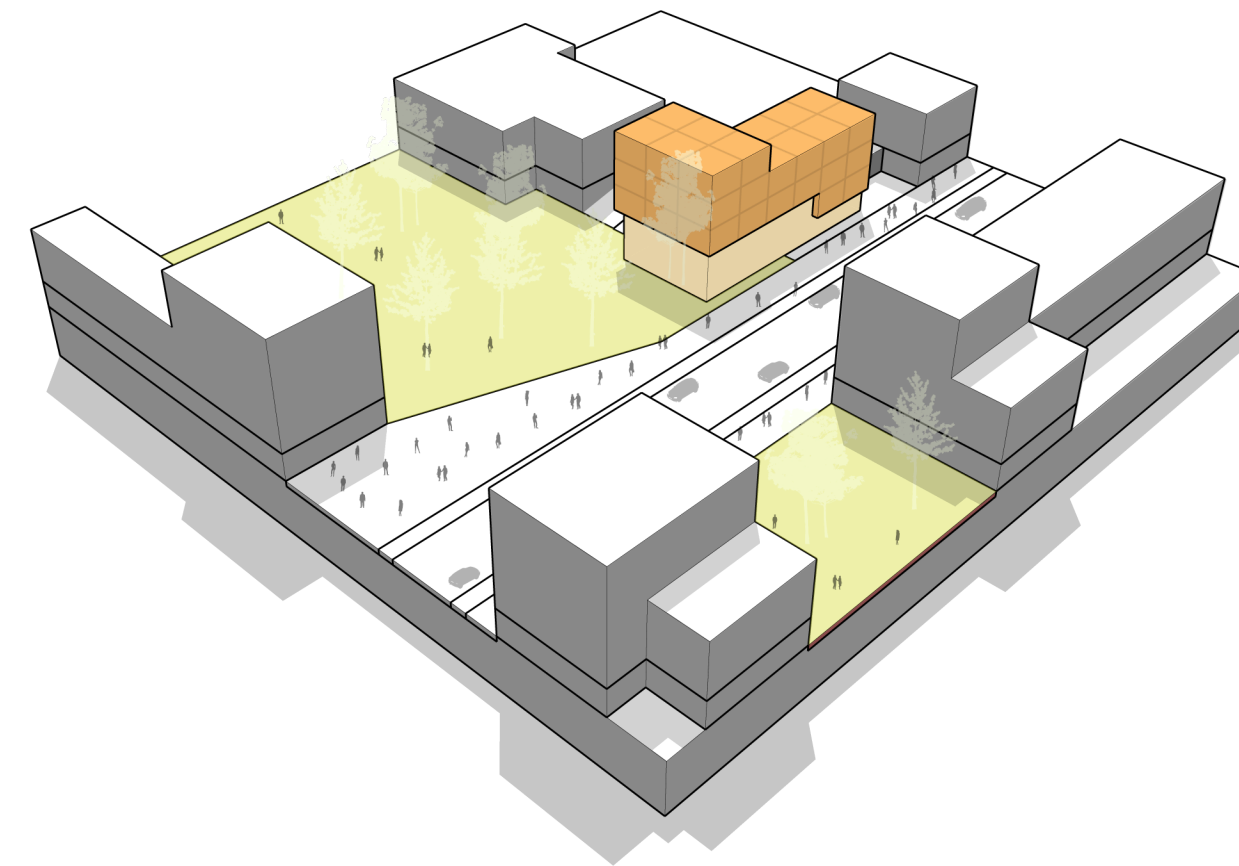

Phase 3: The Circle Community Building  
The Meeting Area

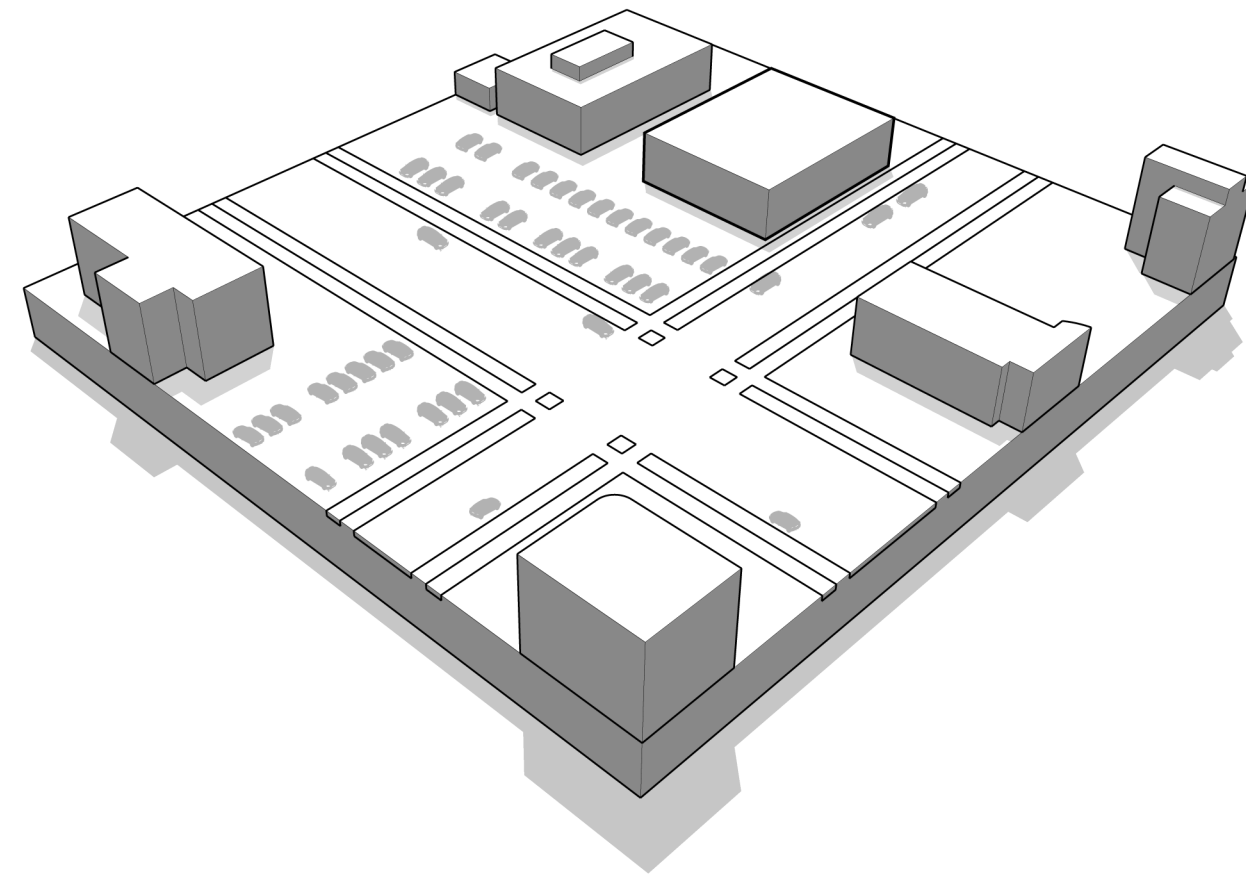

Phase 1: The old Building

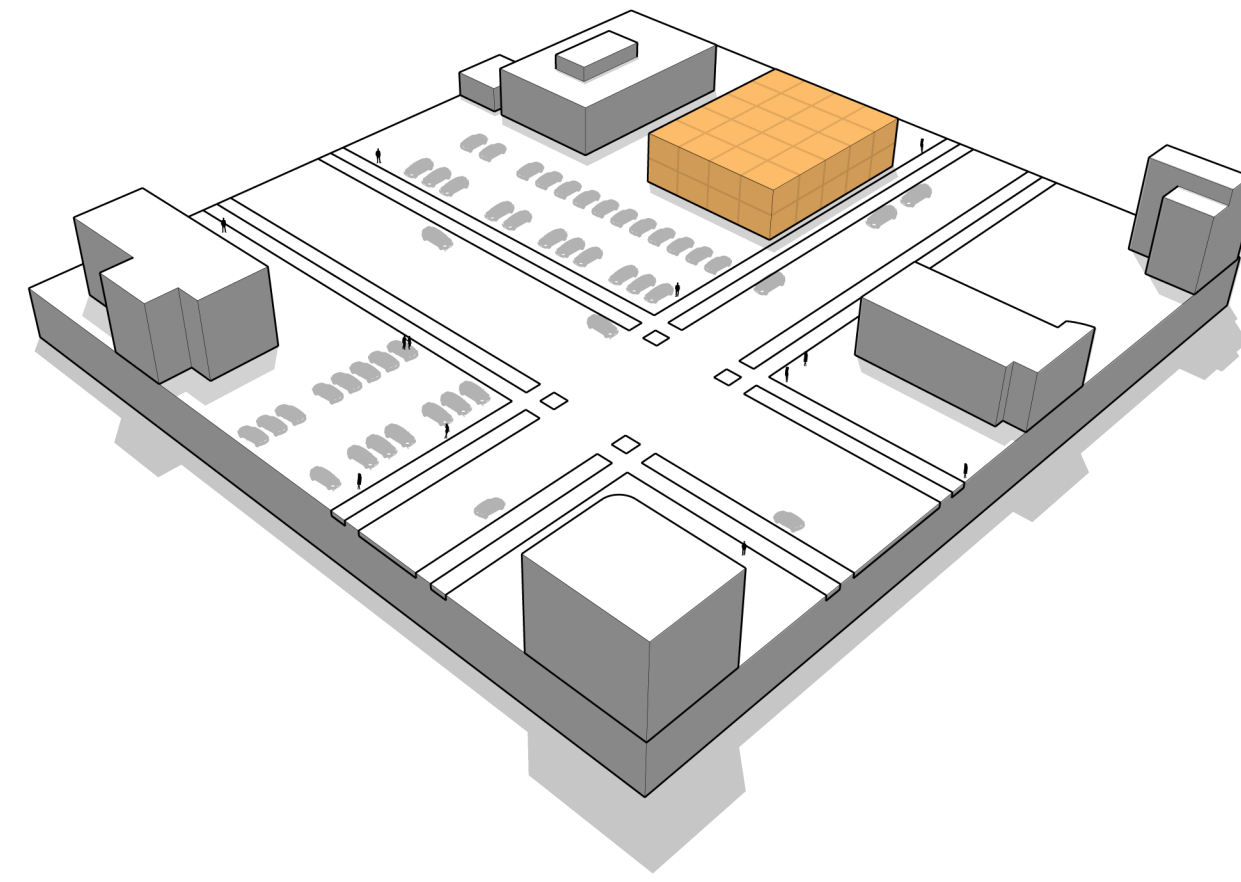

Phase 2: The Circle Building

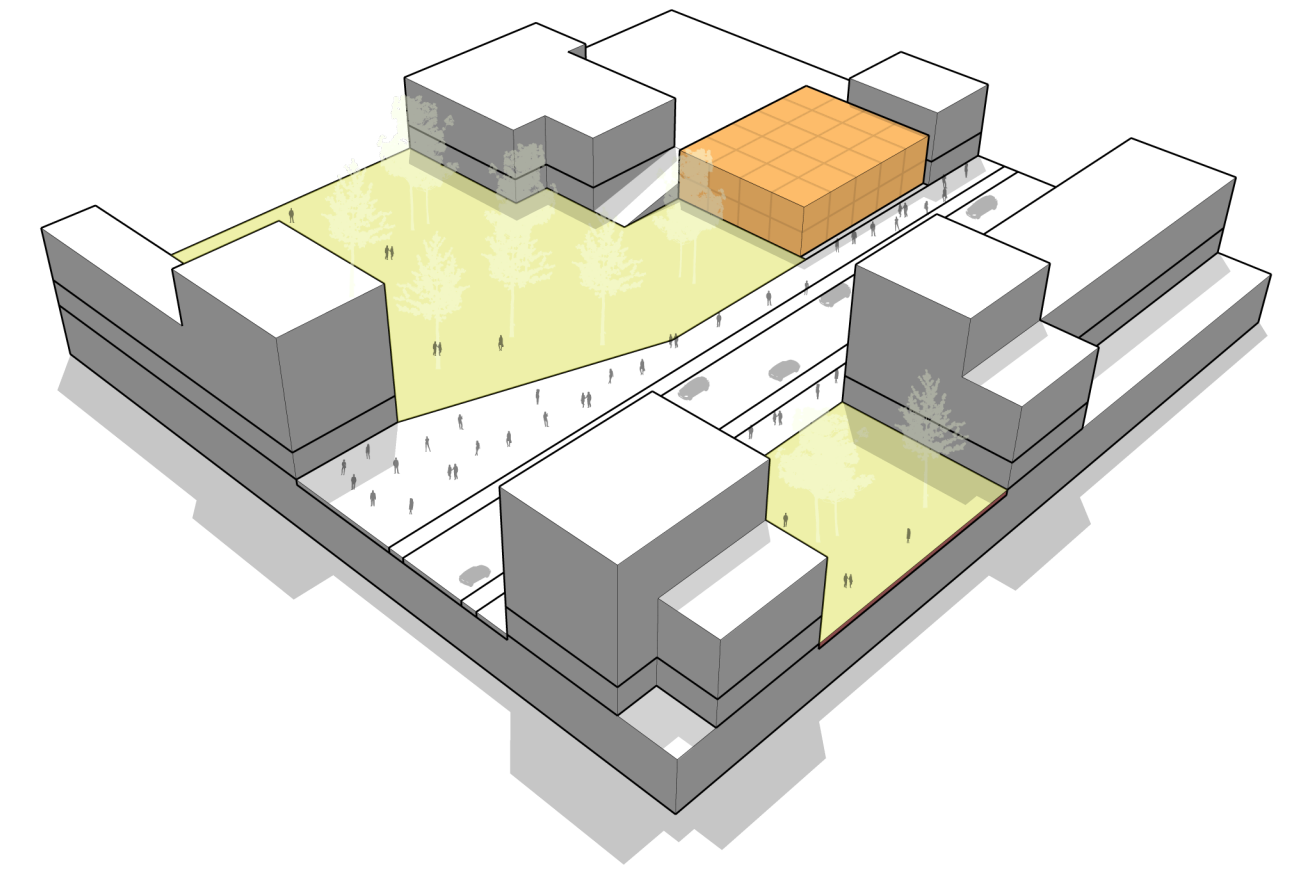

Area Development 2030

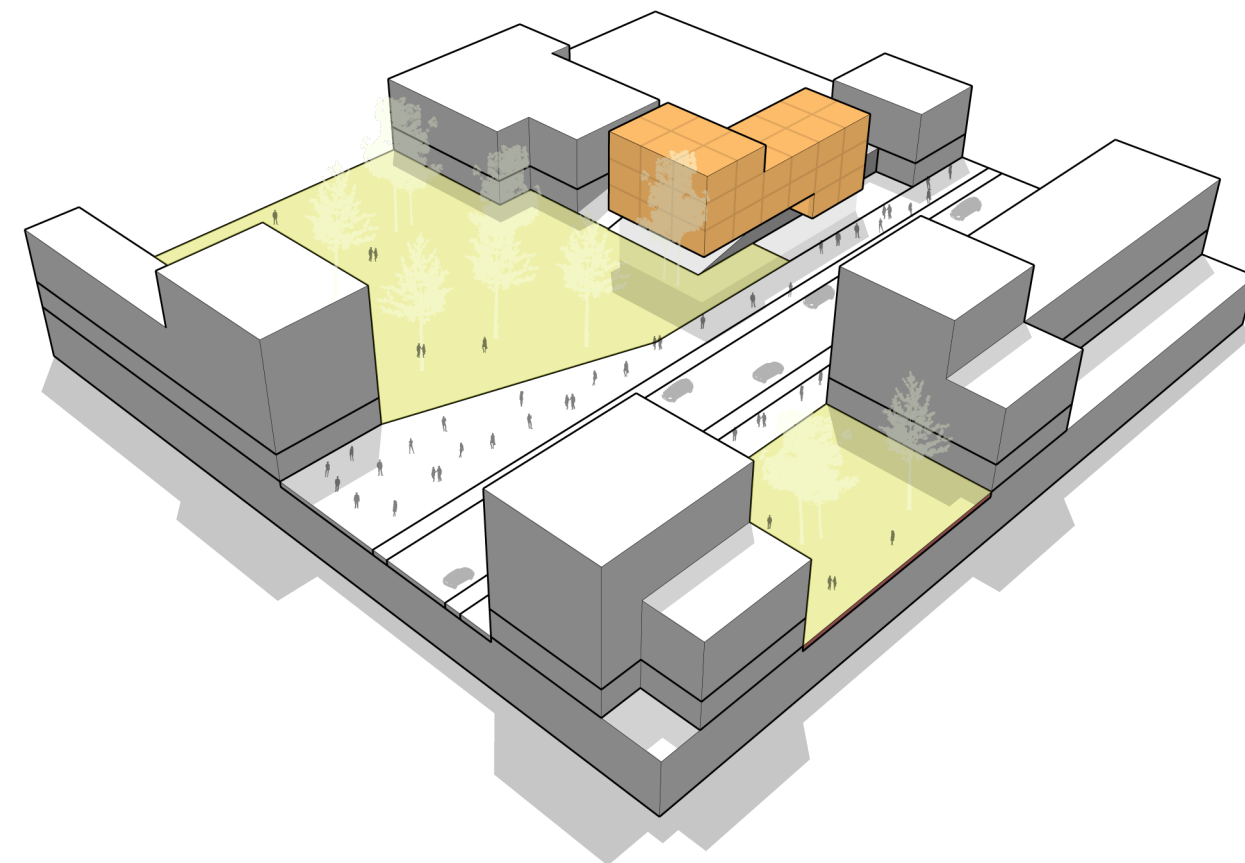

Phase 3: The Circle Community Building  
The Development Area

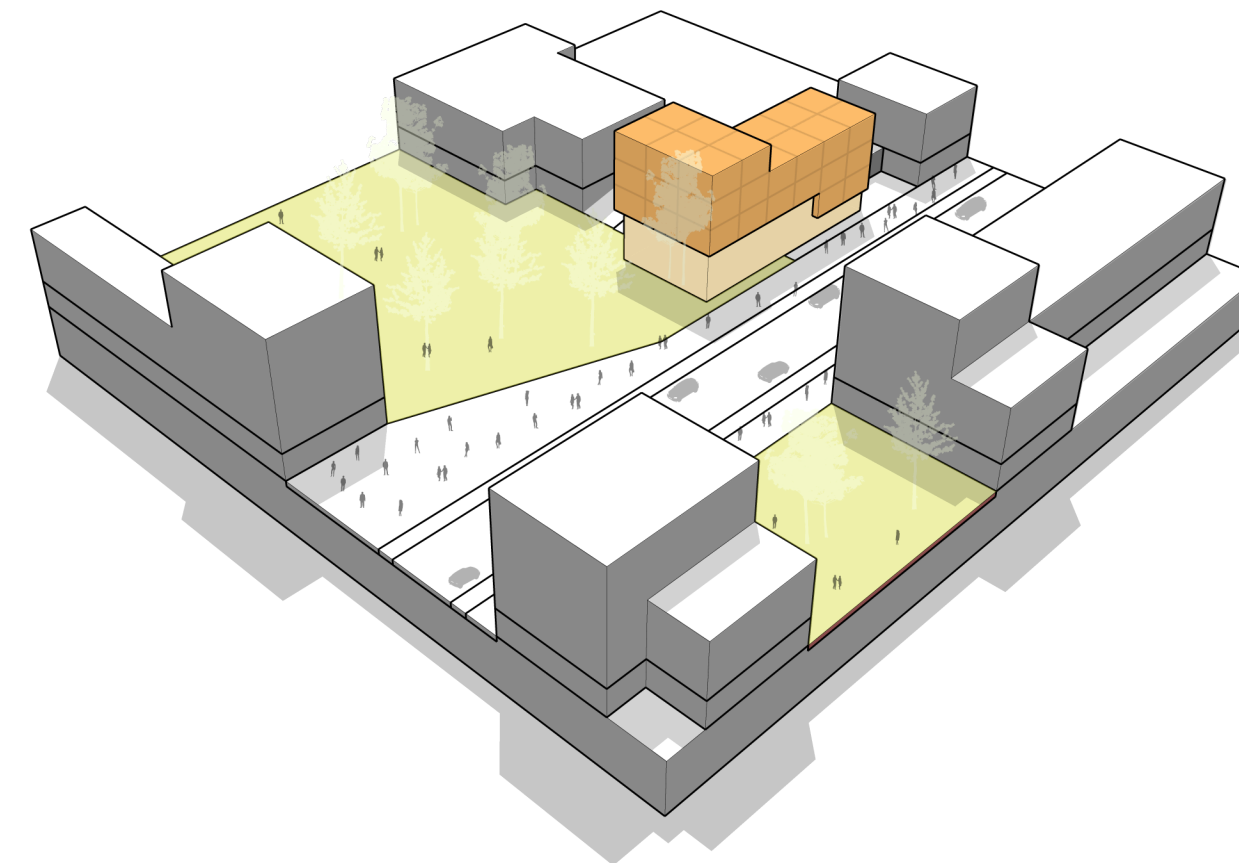

Phase 3: The Circle Community Building  
The Meeting Area

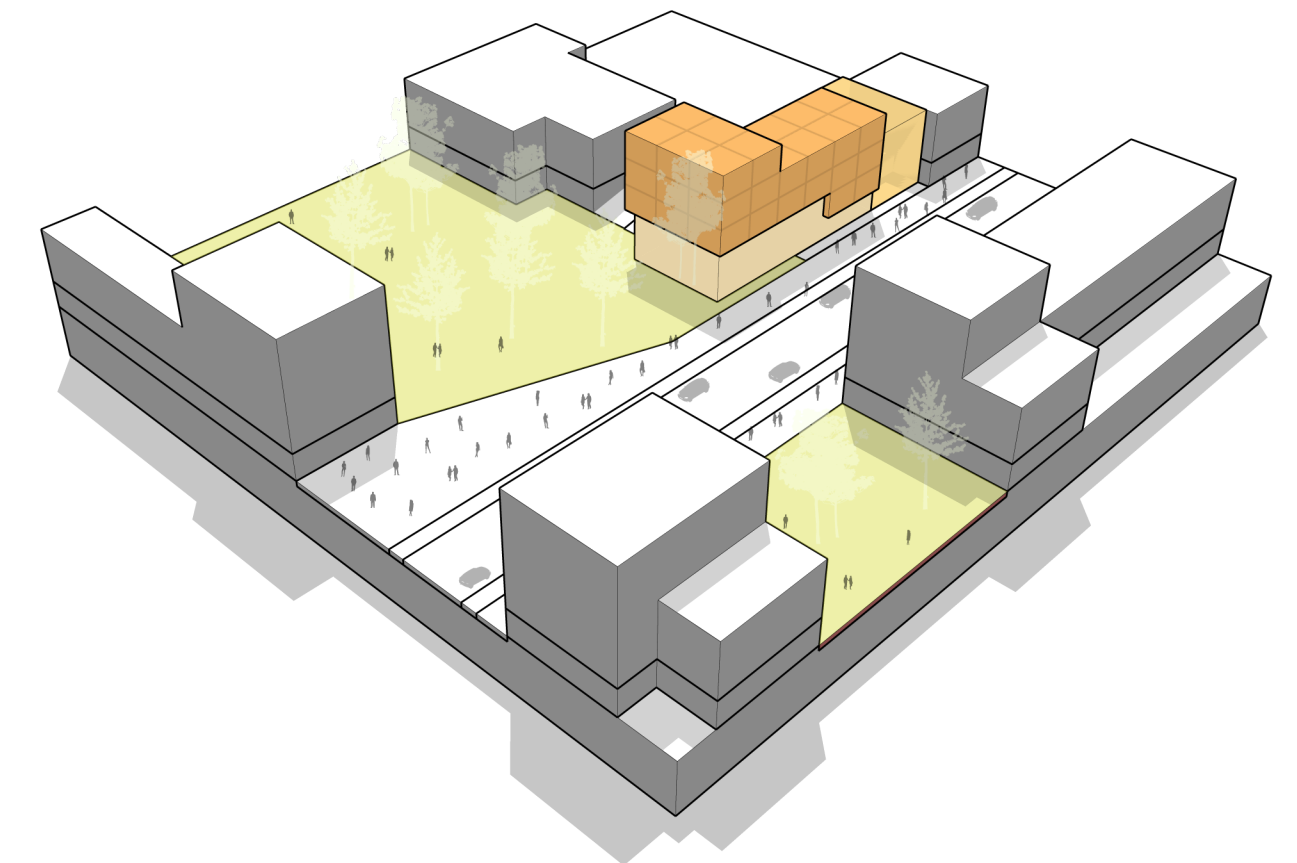

Phase 3: Build new public space around it.  
The Learning Area.



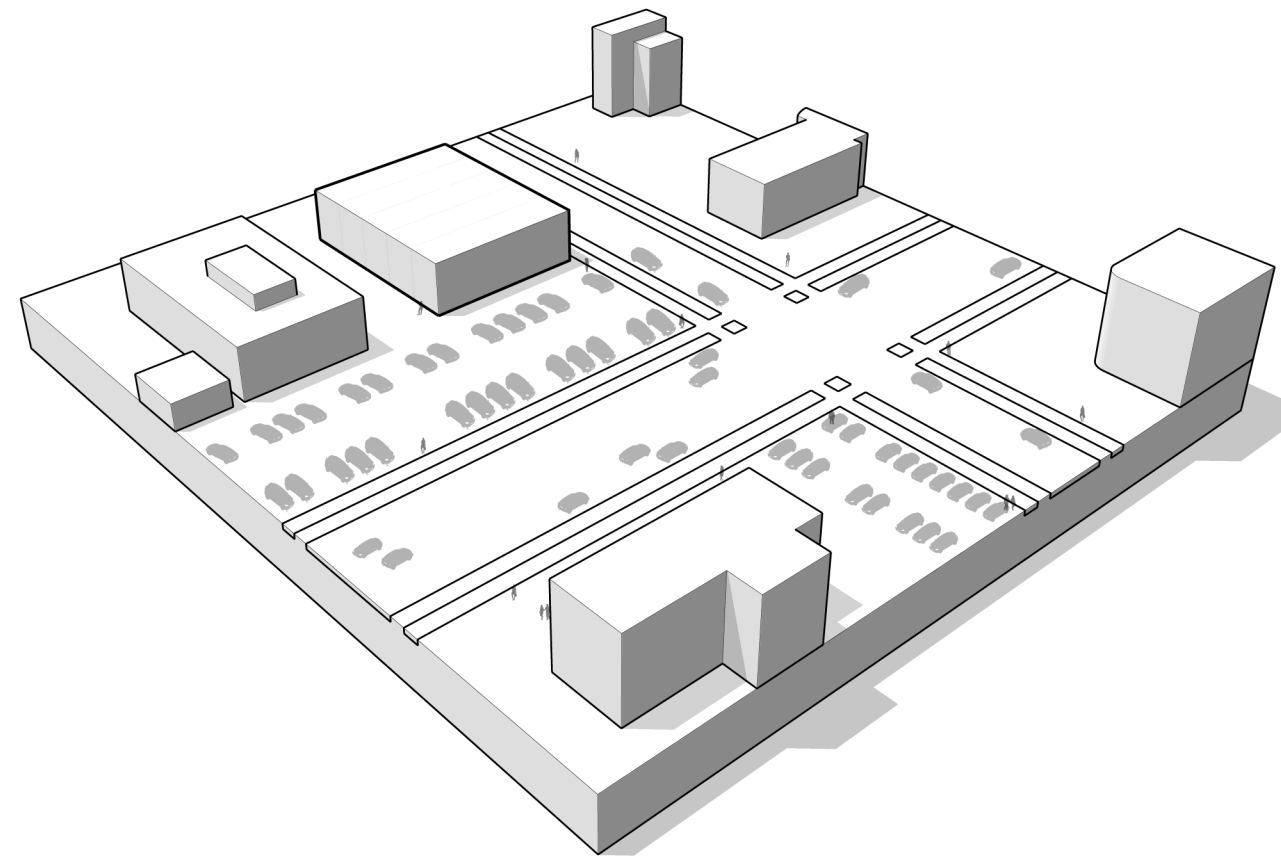

Phase 1: The old Building

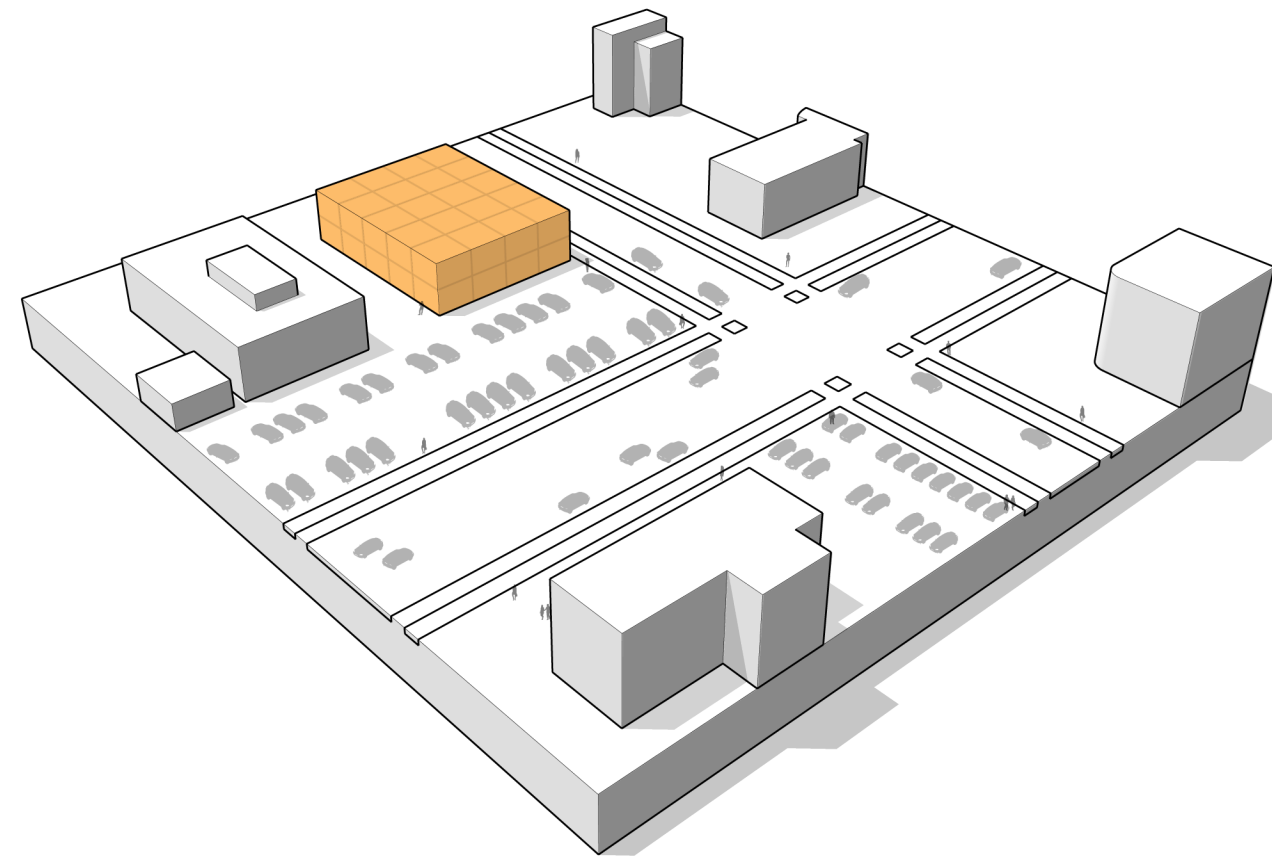

Phase 2: The Circle Building

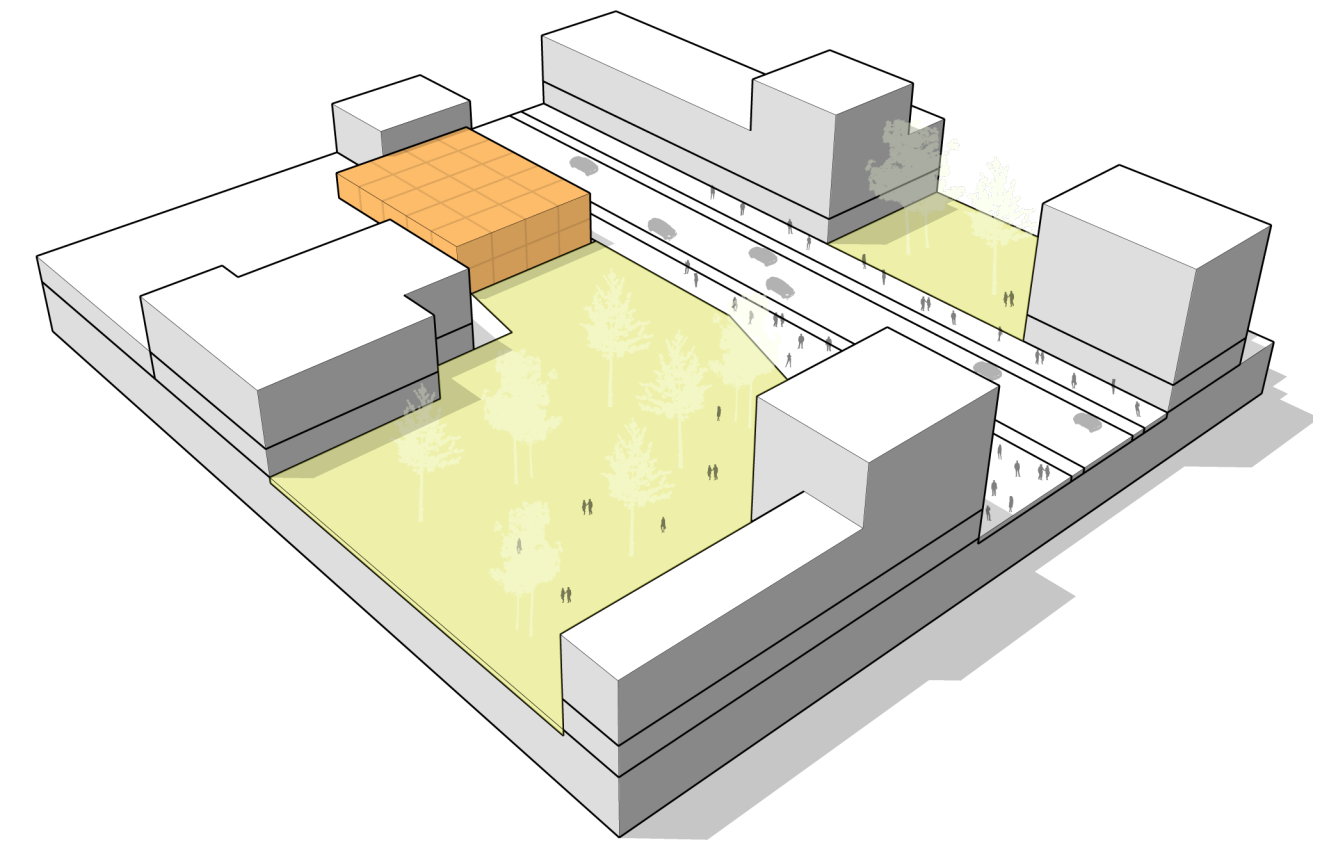

Area Development 2030

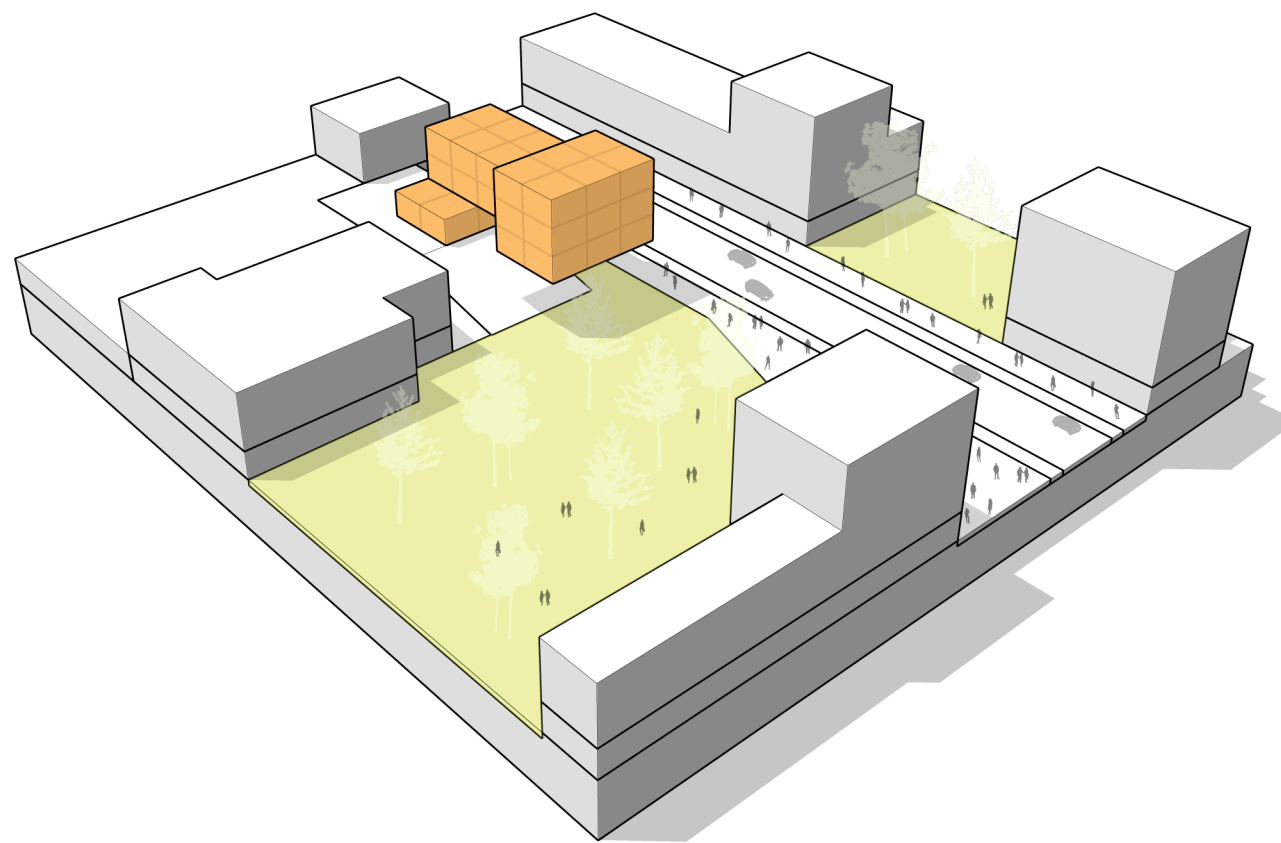

Phase 3: The Circle Community Building  
The Development Area

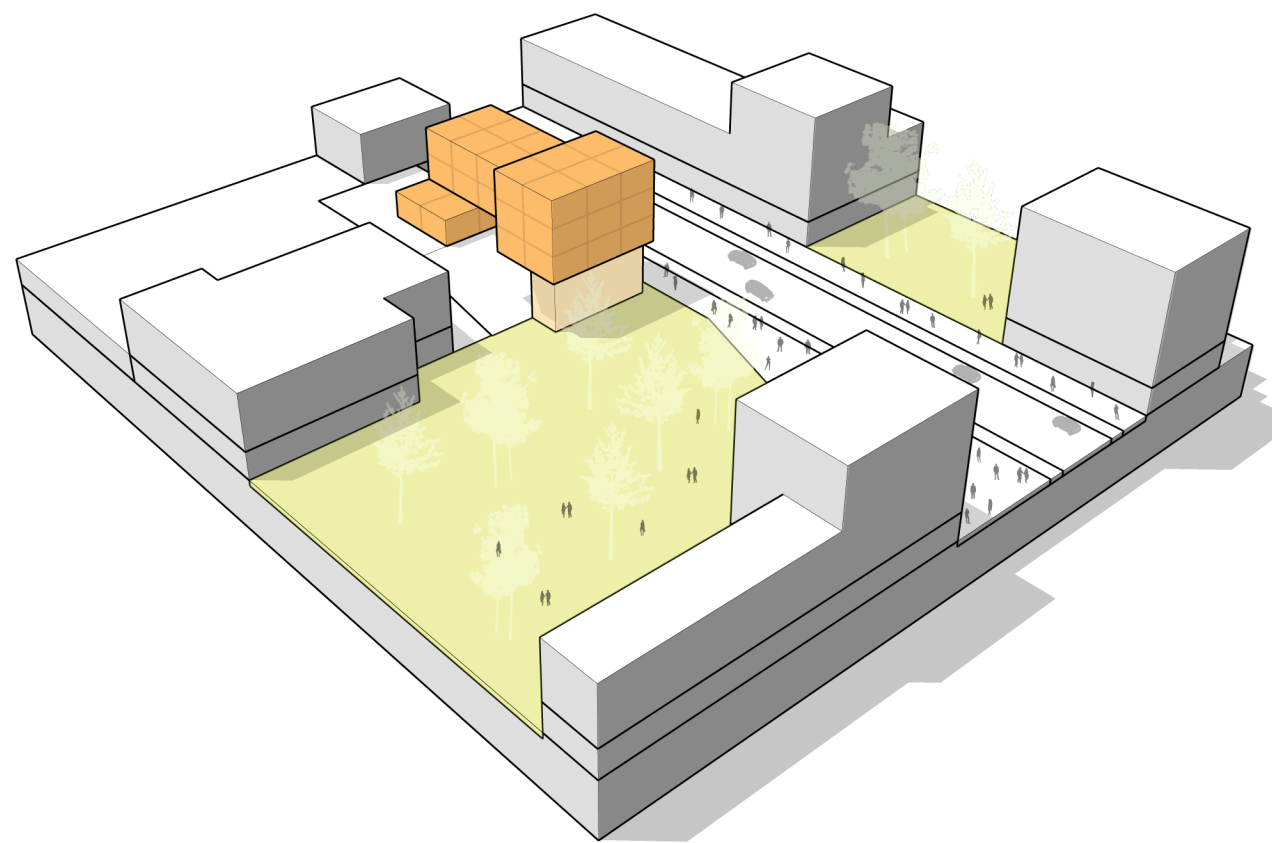

Phase 3: The Circle Community Building  
The Meeting Area

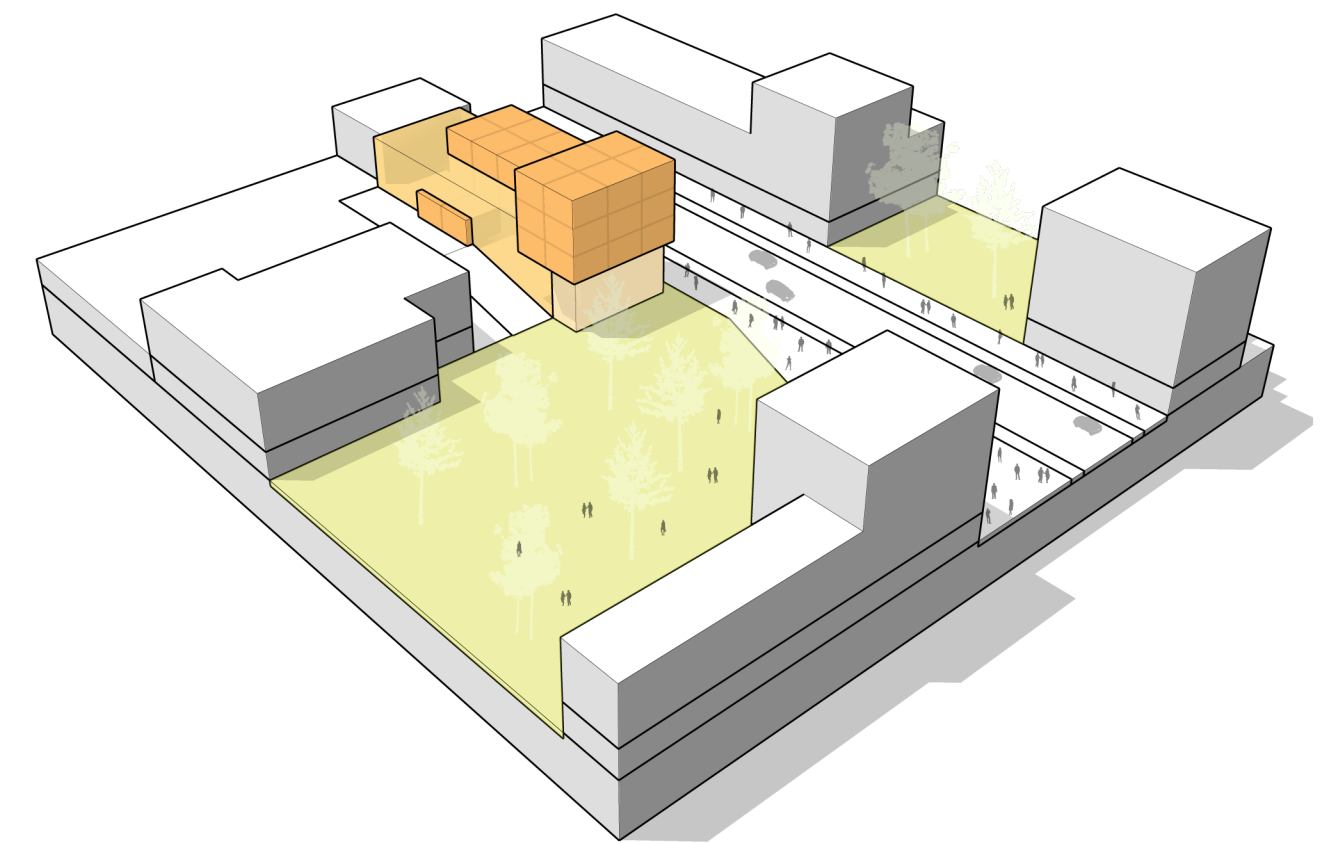

Phase 3: Build new public space around it.  
The Learning Area.

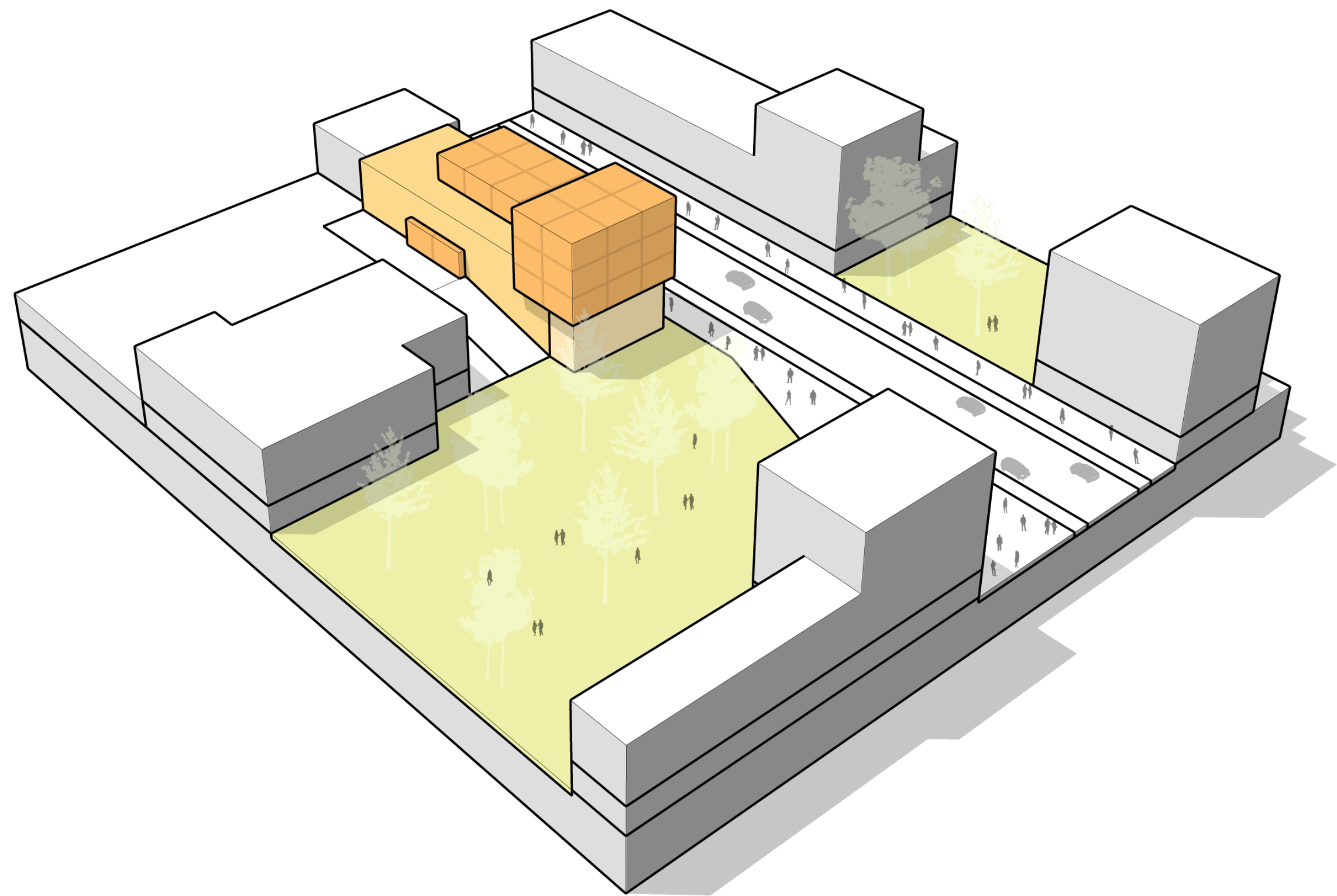



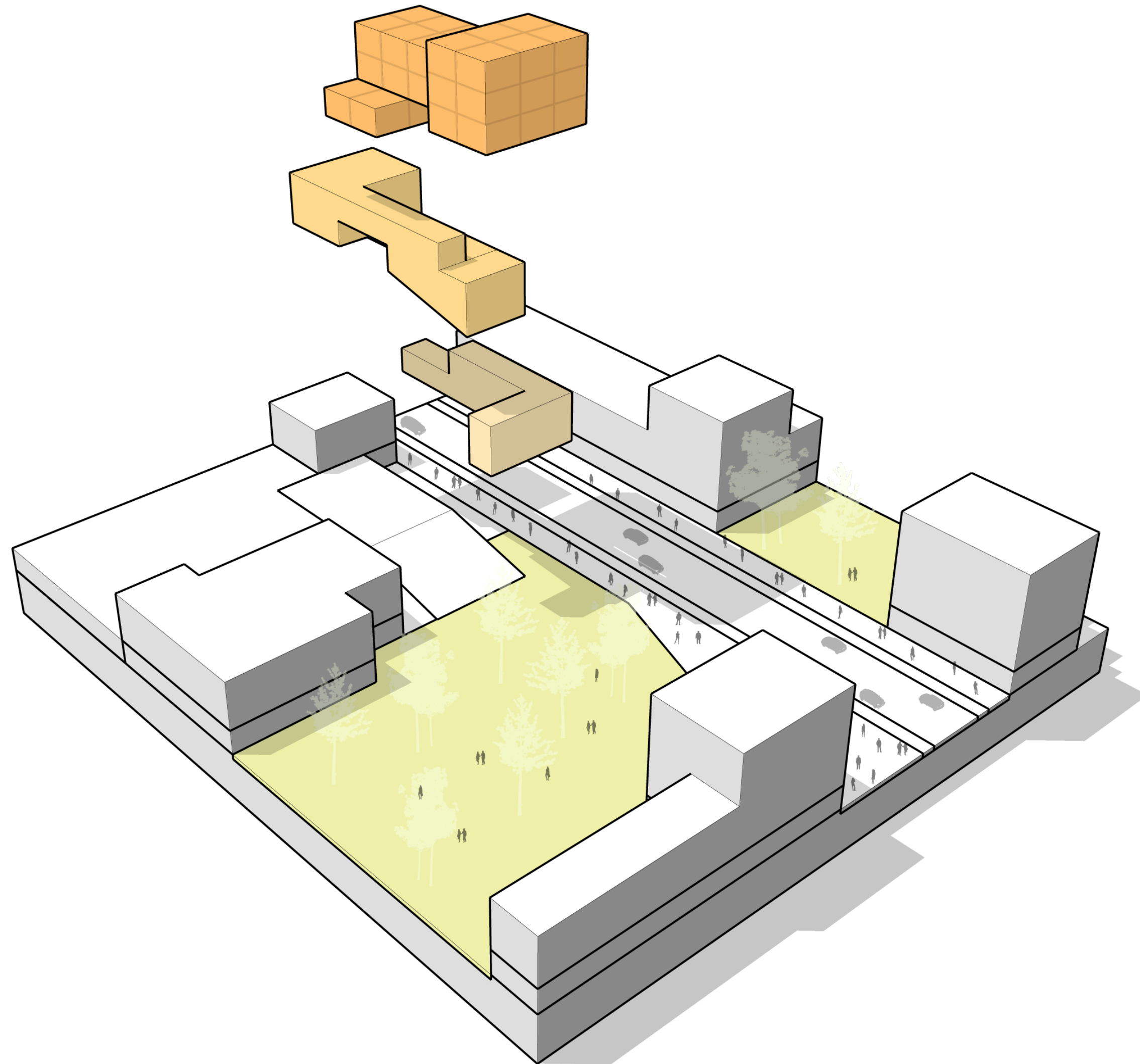

**DEVELOP** 2000m<sup>2</sup>  
Co-working area

**LEARN** 1000 m<sup>2</sup>  
Cultural meeting place / Third room.

**MEET** 350 m<sup>2</sup>  
Cafe / restaurant.

Parking Garage

# Drawings



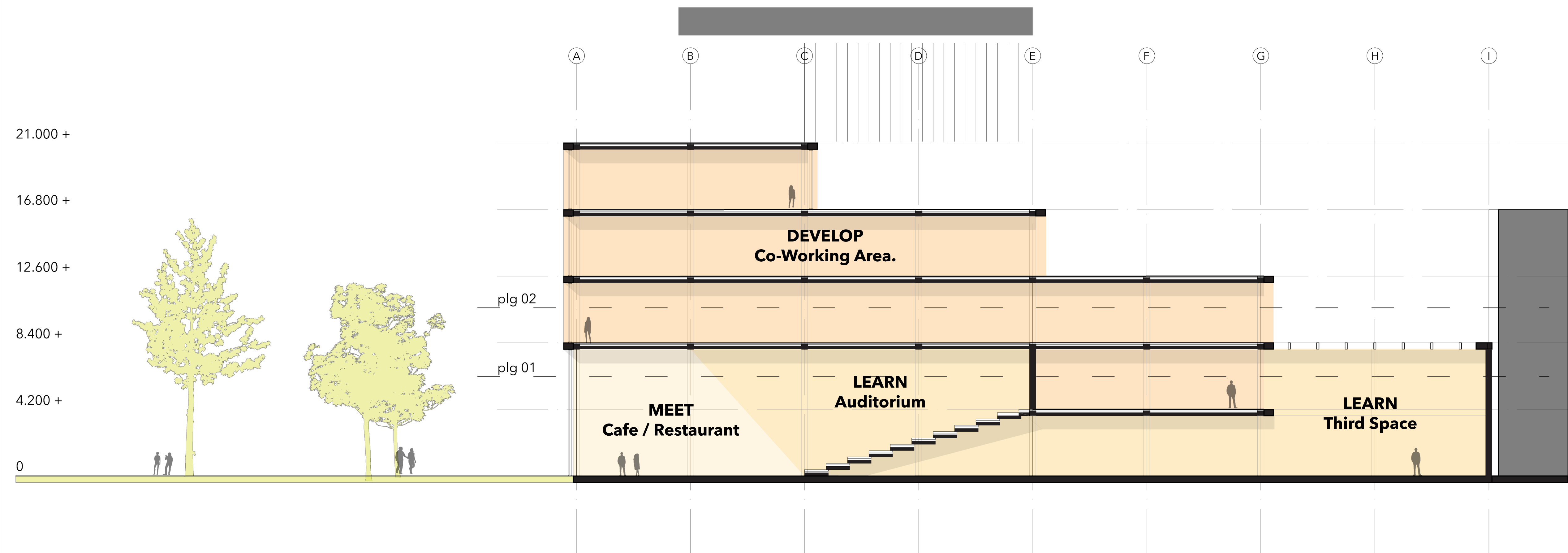

**SECTION AA**

1:200

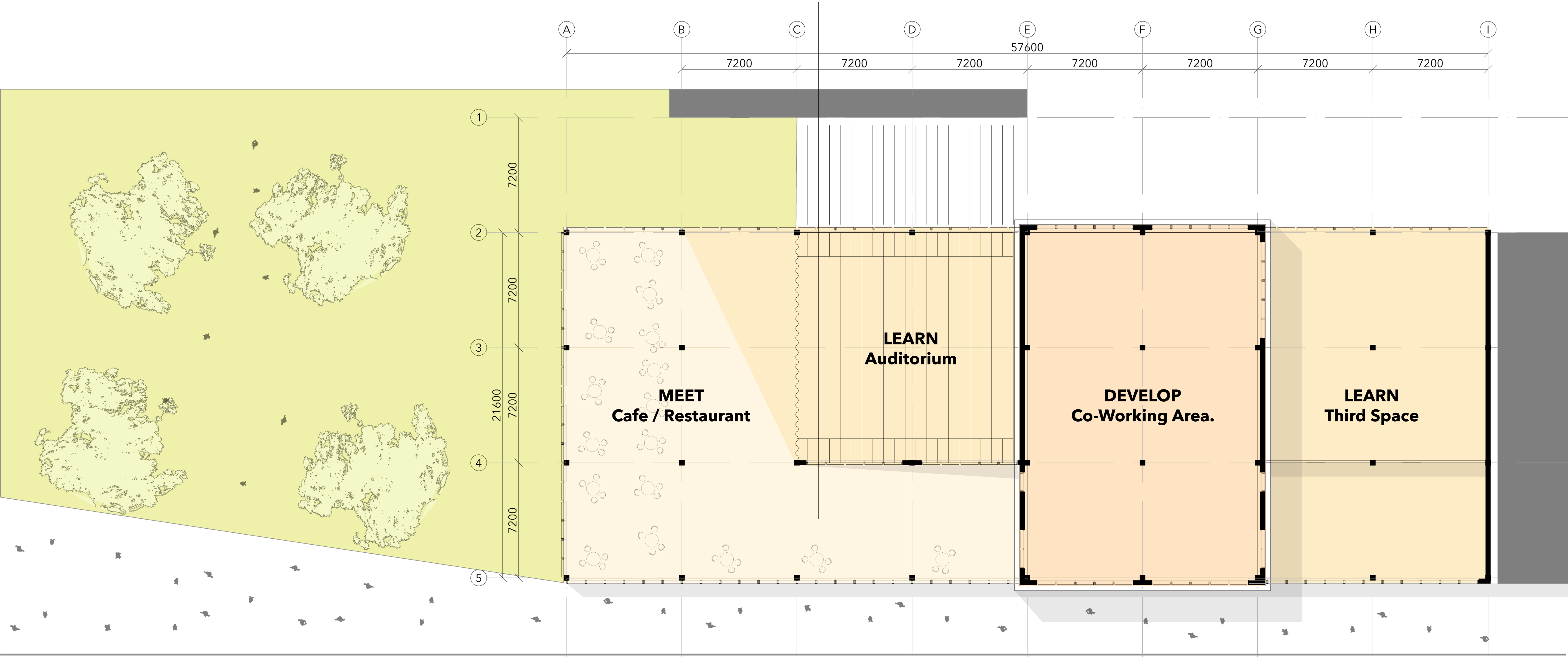

**FLOOR PLAN 01**

1:200



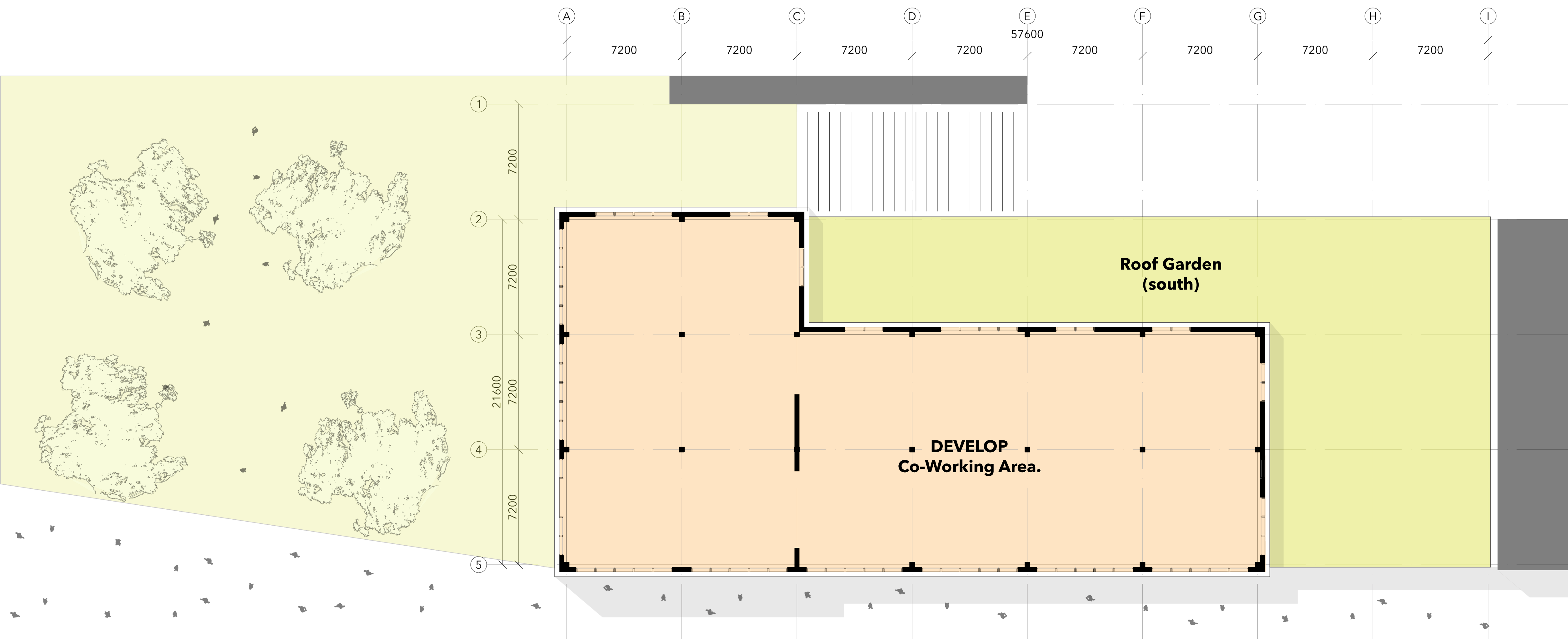

**FLOOR PLAN 02**

1:200

# Conclusion



# CONCEPT : CONCLUSIONS

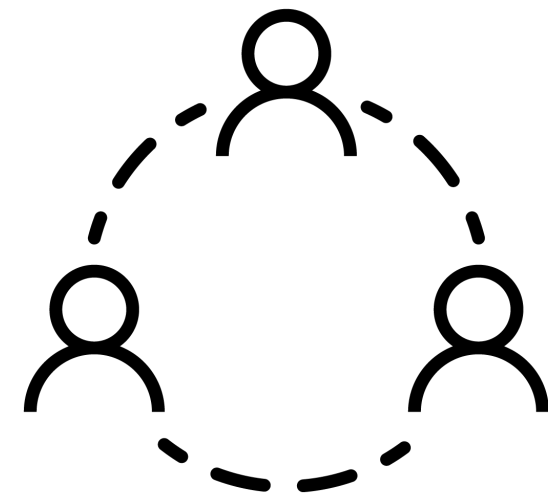

## **INTEGRATE CULTURE**

Merge Work, Culture and living.  
New beating social heart  
of the neighborhood.



## **MEETING POINT**

Cultural meeting point for locals.  
- Meet  
- Share Culture  
- Develop Knowledge

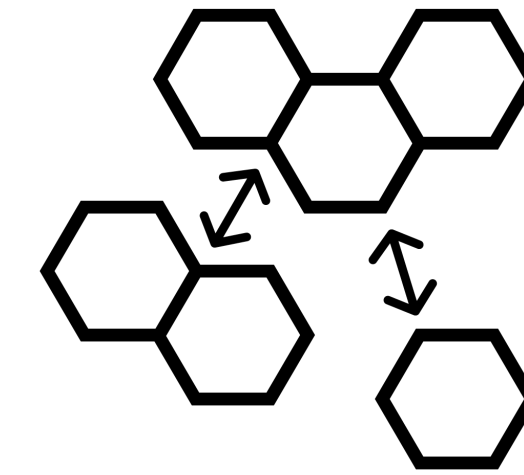

## **DEMONSTRATE CIRCULARITY**

Circular Economy  
Design for disassembly.  
Re-use Components.  
Adaptable to Changing Culture

# THE CULTURAL SOCIAL HUB.

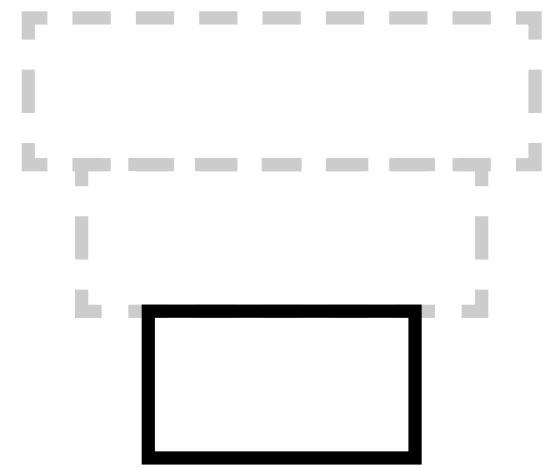

**MEET**

Short encounters

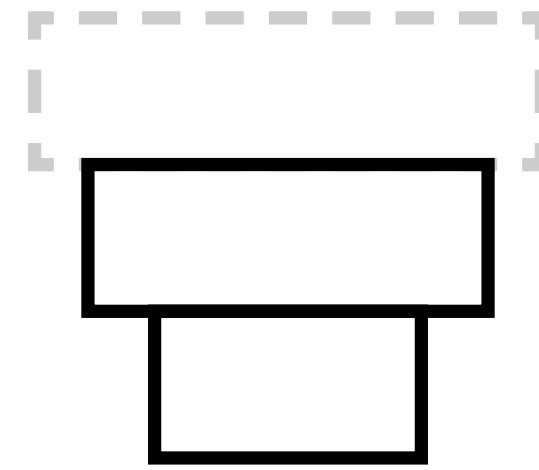

**LEARN**

The third place

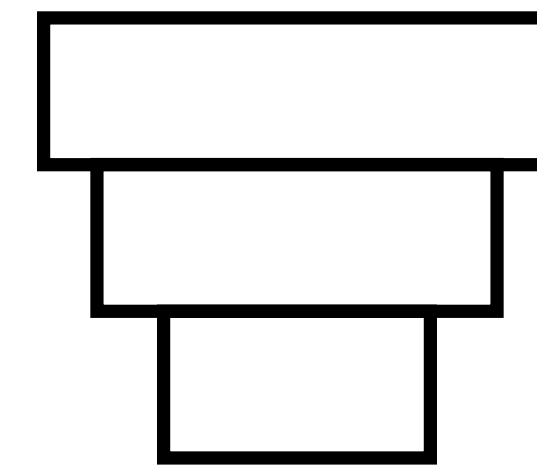

**DEVELOP**

Co-working environment



**Thank you.**





