



APPENDICES

A Project brief

IDE Master Graduation

Project team, Procedural checks and personal Project brief

This document contains the agreements made between student and supervisory team about the student's IDE Master Graduation Project. This document can also include the involvement of an external organisation, however, it does not cover any legal employment relationship that the student and the client (might) agree upon. Next to that, this document facilitates the required procedural checks. In this document:

- The student defines the team, what he/she is going to do/deliver and how that will come about.
- SSC E&SA (Shared Service Center, Education & Student Affairs) reports on the student's registration and study progress.
- IDE's Board of Examiners confirms if the student is allowed to start the Graduation Project.

! USE ADOBE ACROBAT READER TO OPEN, EDIT AND SAVE THIS DOCUMENT

Download again and reopen in case you tried other software, such as Preview (Mac) or a webbrowser.

STUDENT DATA & MASTER PROGRAMME

Save this form according the format "IDE Master Graduation Project Brief_familyname_firstname_studentnumber_dd-mm-yyyy". Complete all blue parts of the form and include the approved Project Brief in your Graduation Report as Appendix 1 !



family name	<u>Keijer</u>	Your master programme (only select the options that apply to you):
initials	<u>A.M.</u> given name <u>Anniek</u>	IDE master(s): <input type="radio"/> IPD <input checked="" type="radio"/> DFI <input type="radio"/> SPD
student number	<u>4555341</u>	2 nd non-IDE master: _____
street & no.	_____	individual programme: - - (give date of approval)
zipcode & city	_____	honours programme: <input type="radio"/> Honours Programme Master
country	_____	specialisation / annotation: <input type="radio"/> Medesign
phone	_____	<input type="radio"/> Tech. in Sustainable Design
email	_____	<input type="radio"/> Entrepreneurship

SUPERVISORY TEAM **

Fill in the required data for the supervisory team members. Please check the instructions on the right !

** chair	<u>Jotte de Koning</u>	dept. / section: <u>SDE/DFS</u>
** mentor	<u>Sonja van Dam</u>	dept. / section: <u>SDE/DFS</u>
2 nd mentor	<u>Elisabeth Tschavgova</u>	
	organisation: <u>Schiphol</u>	
	city: <u>Amsterdam</u>	country: <u>The Netherlands</u>
comments (optional)	Sonja and Jotte are both from DFS, but have complementary skills and expertise. Elisabeth is an additional mentor for close collaboration with the TULIPS project. Together this forms a balanced team.	

Chair should request the IDE Board of Examiners for approval of a non-IDE mentor, including a motivation letter and c.v.



Second mentor only applies in case the assignment is hosted by an external organisation.



Ensure a heterogeneous team. In case you wish to include two team members from the same section, please explain why.

APPROVAL PROJECT BRIEF

To be filled in by the chair of the supervisory team.

chair Jotte de Koning date 12 - 04 - 2023 signature 

CHECK STUDY PROGRESS

To be filled in by the SSC E&SA (Shared Service Center, Education & Student Affairs), after approval of the project brief by the Chair. The study progress will be checked for a 2nd time just before the green light meeting.

Master electives no. of EC accumulated in total: 27 EC YES all 1st year master courses passed

Of which, taking the conditional requirements into account, can be part of the exam programme 27 EC NO missing 1st year master courses are:

List of electives obtained before the third semester without approval of the BoE

name Robin den Braber date 12 - 04 - 2023 signature RdB

FORMAL APPROVAL GRADUATION PROJECT

To be filled in by the Board of Examiners of IDE TU Delft. Please check the supervisory team and study the parts of the brief marked **. Next, please assess, (dis)approve and sign this Project Brief, by using the criteria below.

- Does the project fit within the (MSc)-programme of the student (taking into account, if described, the activities done next to the obligatory MSc specific courses)?
- Is the level of the project challenging enough for a MSc IDE graduating student?
- Is the project expected to be doable within 100 working days/20 weeks ?
- Does the composition of the supervisory team comply with the regulations and fit the assignment ?

Content: APPROVED NOT APPROVED

Procedure: APPROVED NOT APPROVED

comments

name Monique von Morgen date - KE 17/4/2023 signature MvM

Behavior change strategies for higher return of PET bottles/cans

project title

Please state the title of your graduation project (above) and the start date and end date (below). Keep the title compact and simple. Do not use abbreviations. The remainder of this document allows you to define and clarify your graduation project.

start date 13 - 03 - 2023

29 - 08 - 2023

end date

INTRODUCTION **

Please describe, the context of your project, and address the main stakeholders (interests) within this context in a concise yet complete manner. Who are involved, what do they value and how do they currently operate within the given context? What are the main opportunities and limitations you are currently aware of (cultural- and social norms, resources (time, money,...), technology, ...).

Greenhouse gas emissions need to be reduced in order to fight climate change. We therefore need to reduce, reuse and recycle our current resources. Consumers also need to be conscious about their footprint and need to make sustainable choices. This graduation project is addressing the need to improve sustainable consumer behavior at airports on returning PET bottles and aluminum cans at Schiphol. The aim of this graduation project is to find possible solutions regarding collection strategies and behavior change strategies to improve the amount of returned PET bottles and cans at the airport. Currently only a fraction is returned to be recycled at Schiphol, so there is much room for improvement. See image 1 for a preliminary overview of the stakeholders that are important in the waste streams of Schiphol.

Schiphol has the goal to be zero-waste by 2030, which means that "all raw materials, components and products will be reused or recycled to the maximum extent possible according to the waste hierarchy" (Royal Schiphol Group, 2022). Returning PET bottles and aluminum cans, helps to reuse the materials used for bottles and cans. Next to this, recycling bottles is more sustainable than making new ones: it uses less virgin materials, less energy, and creates less carbon dioxide (Dearth, 2020). The Netherlands has legislation which includes that there is a deposit paid with every PET bottle. From the 1st of April, this legislation will also include aluminum cans.

The end of life phase of a PET bottle or aluminum can at Schiphol can go 3 ways, after it is either bought at Schiphol or brought in from outside the airport. Option (1): it is discarded in a PET donation box (see image 2); (2) it is discarded in the residual or plastic waste bin; (3) it is taken away from Schiphol grounds (through a flight or taking it home) and discarded elsewhere.

From a previous own study, where stakeholders in the airport's PET bottle collection system were interviewed, limitations were found that cause the current low amount of returned PET bottles. First, there are practical limitations: there is no way to get the deposit back in the current context (there are no reverse vending machines present, only donation boxes as RVMs are expensive to purchase and maintain). Second, international plastic bottles do not come with a deposit scheme and make for a large diversity in bottles and cans. Ideally these are also collected. A final limitation is that waste in the donation boxes are contaminated with other waste, which makes recycling less effective.

For the future intervention to be designed, some challenges arise from the given context. At Schiphol there is a large diversity of people, from countries all over the world. People come from countries with different systems for plastic bottle recycling, with different bottles and cans and different habits or practices around it. The challenge is to design a system or intervention that is universally understandable regarding practical use. Another challenge is that passengers do not speak the same textual nor visual language, this means that the language that will be used needs to be understandable for multiple cultures. Last, in the context of an airport people are in a hurry and do not have time to extensively search for a PET bottle or aluminum cans collection point.

This graduation is part of TULIPS, a project funded under the European Union's Horizon 2020 research and innovation program. It responds on the Green Deal and aims to reduce (and even eliminate) emissions at airports. Schiphol will be the facilitator of this project, to be able to (make and) test prototypes in the context of an airport.

space available for images / figures on next page

introduction (continued): space for images

Stakeholder overview

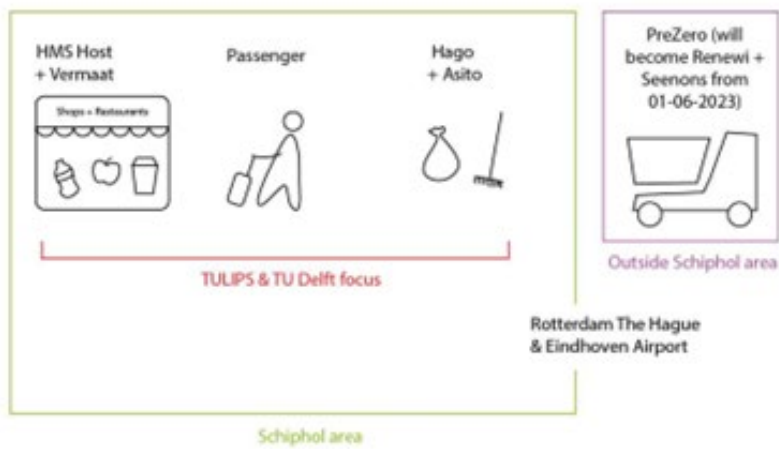

image / figure 1: Preliminary stakeholder overview



image / figure 2: Donation box for PET bottles

PROBLEM DEFINITION **

Limit and define the scope and solution space of your project to one that is manageable within one Master Graduation Project of 30 EC (= 20 full time weeks or 100 working days) and clearly indicate what issue(s) should be addressed in this project.

This project will focus on a return system for PET bottles and aluminum cans at Schiphol airport for its passengers. The research questions that will be answered are:

- What practices do people currently have around the use and discarding of PET bottles and aluminum cans?
- What are current barriers for returning PET bottles and aluminum cans?
- Which behavior change interventions are relevant for Schiphol to stimulate passengers to return PET bottles and cans?

The three main challenges that I see in this project are:

- 1) To find a common ground for the multicultural environment of the airport in returning PET bottles and cans. It needs to be understandable by multiple cultures as they have different cultural practices. This means that the system needs to be clear, as different cultures have different ways of disposing a PET bottle/can.
- 2) The deposit/return system needs to be understandable for people from all over the world, by applying universal semiotics that are independent of a user's spoken language.
- 3) The threshold needs to be as low as possible to return a PET bottle/can, as people might be in a hurry to catch their plane and do not have time to seek for collection points.

ASSIGNMENT **

State in 2 or 3 sentences what you are going to research, design, create and / or generate, that will solve (part of) the issue(s) pointed out in "problem definition". Then illustrate this assignment by indicating what kind of solution you expect and / or aim to deliver, for instance: a product, a product-service combination, a strategy illustrated through product or product-service combination ideas, ... In case of a Specialisation and/or Annotation, make sure the assignment reflects this/these.

I will find out what the current issues are regarding not returning PET bottles/cans at Schiphol. I will subsequently seek for possibilities that will solve this matter regarding sustainable consumer behavior.

My design challenge for this project is: How can the number of returned PET bottles and cans at Schiphol be increased?

The solution which will be made, will aim to stimulate behavior change of passengers. The main outcome will be a solution that will enable the return of PET bottles and cans at airports, a system that is clear and accessible for multiple cultures.

The aim of this project will be design for behavioural change (Delft Design Guide). I will therefore dive into the sociocultural context of passengers in order to understand individual behaviours of a multicultural group.

- I will study the current situations at Schiphol through observational research, interviews with stakeholders and passengers/international students, and will conduct (literature) research on sustainable consumer behavior change strategies.

- Next to that, co-creation sessions and observations will be done to include the passengers in the project to gather understanding of their behaviour. The insights of these activities enable the creation of potential design directions on PET bottle and aluminum can collection with a tangible product (system).

- Following, I will test one of the possible solutions in the context of Schiphol.

- Finally, I will use these insights to will deliver a set of recommendations on how to use a tangible PET bottle and aluminum can collection product that will be implemented at Schiphol.

PLANNING AND APPROACH **

Include a Gantt Chart (replace the example below - more examples can be found in Manual 2) that shows the different phases of your project, deliverables you have in mind, meetings, and how you plan to spend your time. Please note that all activities should fit within the given net time of 30 EC = 20 full time weeks or 100 working days, and your planning should include a kick-off meeting, mid-term meeting, green light meeting and graduation ceremony. Illustrate your Gantt Chart by, for instance, explaining your approach, and please indicate periods of part-time activities and/or periods of not spending time on your graduation project, if any, for instance because of holidays or parallel activities.

start date 13 - 3 - 2023 end date 29 - 8 - 2023

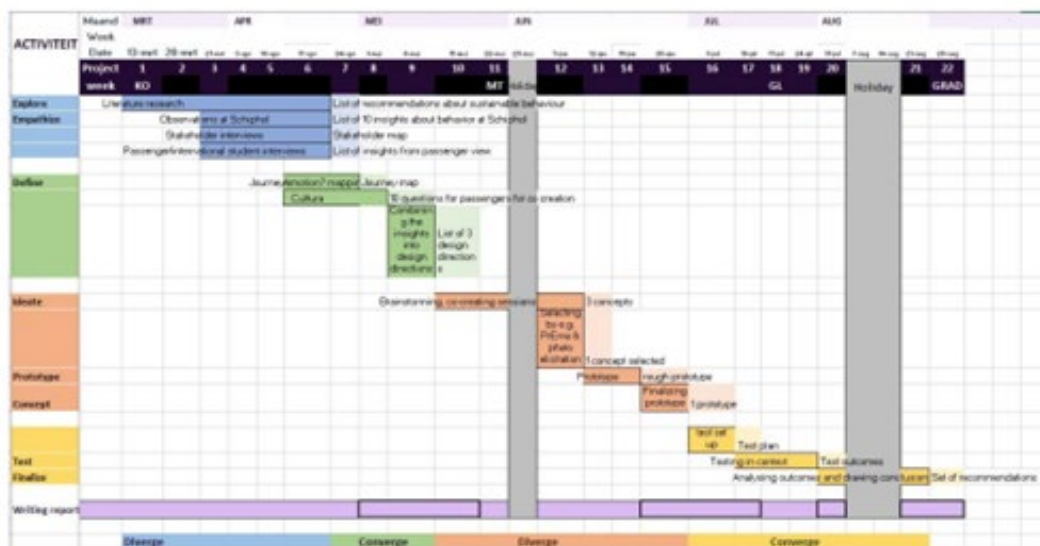

The design process which I will be using is the double diamond. It has four stages, which form two diamonds. Per diamond I will have a diverging stage, where I will expand and broaden the information and insights. Subsequently there will be a converging stage in each diamond, where selections and choices will be made.

- In the first diverging phase I will focus on doing research. By doing literature research I will gather insight on the importance of collecting PET bottles and cans, and I will gather insight about sustainable consumer behavior. By doing user observations at schiphol I will be able to gather information about the context. By doing interviews at Schiphol I will gather more information about motivations to return or to not return their bottles and Schiphol's stakeholders.
- For the first converging step I will map the customer journey of buying a PET bottle/can to returning it to a collection point. I will use Cultura (Delft Design Guide) to gain understanding in cross cultural situations. It will give a more comprehensive view on the cultural context. After that, the more detailed problem definition is formed by the research conclusions. The insights from the previous activities are combined to form design directions.
- In the second diverging phase, I will conduct co creating sessions with international passengers/students in order to use their insights. I will then create a prototype which includes these insights.
- In the last converging phase I will prepare a test and test the prototype in the context by placing a tangible product at Schiphol and interview passenger who use it. The outcomes will be summarized and conclusions will be made.

For writing the report, I plan to do this every week for one morning/afternoon a week. During busier times I highlighted the report writing as I expect writing then to be more time consuming.

MOTIVATION AND PERSONAL AMBITIONS

Explain why you set up this project, what competences you want to prove and learn. For example: acquired competences from your MSc programme, the elective semester, extra-curricular activities (etc.) and point out the competences you have yet developed. Optionally, describe which personal learning ambitions you explicitly want to address in this project, on top of the learning objectives of the Graduation Project, such as: in depth knowledge a on specific subject, broadening your competences or experimenting with a specific tool and/or methodology, Stick to no more than five ambitions.

What I want to learn:

I want to learn how to use design for emotion in this graduation project. I can see that this could play a role in the understanding of behaviour of current visitors. I learned different aspects about this topic in a block course, but I would like to implement it in this project.

Next to this, I want to learn to be more critical about my own work and make this like a habit, to reflect and be critical on myself. This also includes making decisions by myself and being able to feel confident about them.

What I want to prove:

That I am able to design fruitful co creation sessions with multi cultural participants.

This project is a perfect match for me as sustainable consumer behavior related research was the first topic which made me enthusiastic about doing research for. During the elective sustainable consumer behavior, I became more skilled in doing relevant literature research to be able to generate relevant insights from it. Our project in this course mostly focused on Dutch market, and I would love to expand my knowledge about multiple cultures regarding sustainable behavior. Also, this project makes me apply my gathered knowledge, which is an extra step that I would love to learn more about.

Next to this I am very enthusiastic to help design for a sustainable future. I am aware that this is a very big and challenging topic overall, but in my opinion this can be solved by cutting this into smaller projects and topics to later be able to address sustainability for a bigger impact. I am therefore eager to start working on this, in order to contribute to a sustainable future.

Lastly, I want to be proud of the outcome. I want to show that I am capable of doing this project and come up with a creative outcome, which is hopefully new and inspiring to Tulips and airports in the future.

FINAL COMMENTS

In case your project brief needs final comments, please add any information you think is relevant.

Dearmitt, C. (2020). The Plastics Paradox: Facts for a Brighter Future.

Royal Schiphol Group. (2022). Sustaining your world: Vision and strategy towards the most sustainable airports. <https://tulips-greenairports.eu/>

B Interview questions passengers

Interview setup Schiphol



General information:

- **Area where I want to conduct interviews:**
I would like to conduct interviews near the gates. This is where people already passed some options to buy PET bottles/cans and options to dispose of the bottle.
- **Date of interview: One of the following dates**
 - Monday 8th of May 14.00 – 17.00
 - Tuesday 9th of May 9.00 – 17.00
 - Wednesday 10th of May 9.00 – 12.00
 - Thursday 11th of May 14.00 – 17.00
 - Friday 12th of May 9.00 – 17.00
- **Duration of interview:** 10 minutes per participant
- **Ideal sample number:** 5 to 10 participants

Intro

- Recruit someone who is possibly buying a bottle or can. If there are no people available -> regular passengers. Do you have 10 minutes to answer some questions?
- I am doing research about PET bottles and cans at the airport, is it possible to ask some questions to you about waste disposal habits?
- Is it okay if I record this interview? This recording will only be used for internal research (to listen back) and will not be shared with others. It is anonymous and not traceable back to you.
- Consent form will be signed

What is your home country?

Use and disposal of PET bottles/aluminum cans

PET bottles & Existing practices

- Do you typically buy drinks in PET bottles or cans when you travel? When is it the case that you buy a drink?
- Do you typically buy drinks in PET bottles or cans at home? / Is this also a common practice for you to buy a “coca cola in a PET bottle” at home when you are not traveling?
- What are you planning to do with this bottle when you are done drinking? (they might want to keep it – also interesting to ask follow up on that). / How would you dispose of your PET bottles or cans at the airport?
- How do you typically do that in your home country? Is there a recycling system in place?
- Have you noticed any recycling bins for disposing of PET bottles or aluminum cans at the airport? Where were they situated? Was it clear to you where and how to dispose of them?

- Do you know if the situation in your home country differs from the situation here at Schiphol? How?

Sustainability

- What does sustainability mean to you?
- On a scale of 1 to 10, how much do you consider yourself to be sustainability-oriented? 1 not at all – 10 Fully aware of sustainability in my life.
- Are you aware of the environmental impact of single-use plastic bottles and aluminum cans?

If there is time:

- Do you make a conscious effort to reduce your use of single-use plastics while traveling? In what ways?
- What do you think airports and airlines could do to promote sustainable behavior among travelers?

Existing practices

- Are you aware of any recycling or waste reduction initiatives at the airport or within the aviation industry?
- Do you have any suggestions for how the airport could improve its recycling or waste reduction efforts?

Thanks

- Thank you a lot for your time and effort!
- Give a small thank you gift

C Sensitising booklets

PREPARATIONS FOR YOUR TRIP

What are the most important things for you to take on your travels?

1. Passport & ID
2. Fluoride toothpaste
3. Chargers
4. Medicine
5. Headphones

Are you bringing any food or drinks?
Only drinks: water & coffee
But my friend brought some food



EXPECTATIONS OF SCHIPHOL

What do you like about Schiphol?

1. Fair security-check
2. Integration with trains
3. Easy access to toilets
4. Report & control on same level
5. _____

What do you not like about Schiphol?

1. Not a lot of food choices
2. Uneven distribution of shop destinations
3. Not big enough for an international airport
4. _____
5. _____

Step	1	2	3	4
Function	Shopping	Shopping	Shopping	Shopping
Emotion	Happy	Happy	Happy	Happy
Description	I'm perfectly on time & even have time to have some food.	Having to arrange a list of things out there and miss liquids & battery.	It's okay, that's the reason. Take a quick break after security check.	Too less shop along the way, looking to see / buy.

Step	5	6	7	8
Function	Waiting	Waiting	Waiting	Waiting
Emotion	Happy	Happy	Happy	Happy
Description	I'm perfectly on time, looking to wrap up.	Probably too slow. Starting to get the ready before you can already board.	Discomfort due to limited space, looking to do it & no where to move to.	

IN THE PLANE

Is there something at an airport that you always try to avoid? Please try to...

Why?
I always try to avoid hearing loud luggage baggages. I don't like the noise. I don't like the noise. I don't like the noise. I don't like the noise. I don't like the noise.



IN THE PLANE

Is there something you bought at the airport you departed from? What did you do with it?



I took this with me

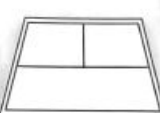

I ate/drank this



I disposed of this (including packaging)

INTRODUCTION

Hi! First of all, thank you so much for wanting to participate in this research. As far as we know, you are about to travel somewhere by plane, and we would like to know more about your coming journey!

This booklet has different pages that we would like you to fill in, the time indication when you have to fill in a page is given on the top right. We will start 2 days before your departure until you are in the plane. The second part (if applicable) will start 1 day before your return flight.

We hope you have fun on your trip, please write/sketch/scribble as many things that you can think of in this booklet!
If you have any questions or comments you can always message Mika ☎ +31 6 49420223 or Annetek ☎ +31 6 42140124

2 DAYS BEFORE DEPARTURE

ABOUT YOUR TRIP

What is your name? _____ What is your age? 25
Why are you travelling? For holiday
Where are you travelling to? Paris, France
What is your nationality? Chinese
What is your departure date? May 18th and arrival? May 21st
What do you like most about travelling by plane?
In most cases it's the fastest way. Besides, no other advantage.

AT THE GATE

Did you buy something at the airport?
Draw/write these items on your food tray
or in your shopping bag!
If you disposed of something also draw/write this! →



I took this with me



I ate/drank this



I disposed of this (including packaging)

ON THE PLANE

Can you sketch your favourite moment between going through security and boarding the plane?

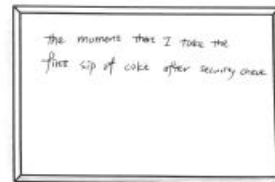

END OF 1ST SECTION // START OF 2ND SECTION!

This was the first section of the booklet! We would like to ask you if you could fill in the second part of the booklet 1 day before your return flight, so please set a reminder/alarm to help you remember.

And again, when you start the next section, please write/sketch/scribble as many things that you can think of in this booklet!

If you have any questions or comments you can always message Mika ☎ +31 6 49420223 or Annetek ☎ +31 6 42140124

BEFORE GOING BACK

What are you looking forward to the most during your trip back?

1. Everything on plane without being
2. take a nice nap on the plane
3. Some nice food from abroad
4. _____
5. _____
6. _____
7. _____



Step	1. Arriving at the airport	2. Check-in	3. Security check	4. Boarding the plane
Food/drink				
Emotion				
Description	Finally home! in plane to other my life!	Too slow & too many people in the que	Missing my luggage! it's soft and stable good!	

Step	5. Getting to the hotel	6. Relaxing in the hotel	7. Leaving the hotel
Food/drink			
Emotion			
Description	Having a good time more after flight & paper myself for them!	Just want to go back home Summer Time are beautiful	Relax! But Belgium really means a lot of things to be done

END OF SECTION 1 // START OF 2ND SECTION

IN THE PLANE

Is there something at an airport that you think is a good idea?

Why?

I always try to avoid waiting. I hold luggage baggages. I avoid going to the airport. I avoid the security check. I avoid the long queues. I avoid the long queues.

AFTER MIDWAY

IN THE PLANE

Is there something you bought at the airport you departed from? What did you do with it?

I took this with me

I ate/drank this

I disposed of this (including packaging)

INTRODUCTION

Hi! First of all, thank you so much for wanting to participate in this research. As far as we know, you are about to travel somewhere by plane, and we would like to know more about your coming journey!

This booklet has different pages that we would like you to fill in, the time indication when you have to fill in a page is given on the top right. We will start **2 days before your departure** until you are in the plane. The second part (if applicable) will start **1 day before your return flight**.

We hope you have fun on your trip, please write/sketch/scribble as many things that you can think of in this booklet!

If you have any questions or comments you can always message Nika [+31 6 40420222](tel:+31640420222) or Anniek [+31 6 42140124](tel:+31642140124)

1 DAY BEFORE DEPARTURE

ABOUT YOUR TRIP

What is your name? _____ What is your age? 25

Why are you travelling? For home celebration my birthday

Where are you travelling to? Paris

What is your nationality? China

What is your departure date? 19/05/2023 and arrival? 22/05/2023

What do you like most about travelling by plane? Fast. It takes 3h by train to Paris but around 1h by plane.

END OF SECTION 1 // START OF 2ND SECTION

AT THE GATE

based on previous experience

Did you buy something at the airport? Draw/write these items on your food tray or in your shopping bag! If you disposed of something also draw/write this!

I took this with me

I ate/drank this

I disposed of this (including packaging)

END OF SECTION 1 // START OF 2ND SECTION

ON THE PLANE

based on previous experience

Can you sketch your favourite moment between going through security and boarding for the plane?

Buy the food and coffee and find a place to sit, which is next to charging port.

END OF SECTION 1 // START OF 2ND SECTION

END OF 1ST SECTION // START OF 2ND SECTION!

This was the first section of the booklet! We would like to ask you if you could fill in the second part of the booklet **1 day before your return flight**, so please set a reminder/alarm to help you remember.

And again, when you start the next section, please write/sketch/scribble as many things that you can think of in this booklet!

If you have any questions or comments you can always message Nika [+31 6 40420222](tel:+31640420222) or Anniek [+31 6 42140124](tel:+31642140124)

END OF SECTION 1 // START OF 2ND SECTION

BEFORE GOING BACK

What are you looking forward to the most during your trip back?

1. Arrive on time
2. Successful get on board an plane
3. _____
4. _____
5. _____
6. _____
7. _____

Step	1. Arriving in Paris	2. Getting to the airport	3. Getting on the plane	4. Getting to the gate	5. Boarding the plane	6. Getting to the destination	7. Getting to the hotel
Food/Drink							
Emotion							
Description	Finally found a place to stay in my city!	Too slow & too many people in the que	Enjoying my luggage!	It's soft and comfortable	Having a good first meal after flying & people enjoying for Paris.	Just want to go back home. Summer, Paris are beautiful.	Relax! But flying really means a lot of things to be done.

PREPARATIONS FOR YOUR TRIP

What are the most important things for you to take on your travels?

1. Passport
2. ID card
3. Bank card
4. Phone
5. Air phone

Are you bringing any food or drinks? No, but I have some different prepared food for us... (Sparking water, Lucho has a drink bottle)

EXPECTATIONS OF SCHIPHOL

What do you like about Schiphol?

1. I don't take out the luggage even when passing security check.
2. Gulp and steam!
3. The App which shows the Luggage level.
- 4.
- 5.

What do not like about Schiphol?

1. Schiphol does not have choices in coffee or water.
2. The pickup point of water is far away from control gate.
- 3.
- 4.
- 5.

Step	1. Getting to the airport	2. Getting to the gate	3. Getting on the plane	4. Getting to the gate	5. Boarding the plane	6. Getting to the destination	7. Getting to the hotel	8. Getting to the hotel	
Food/Drink		N/A or some with perfume	N/A or some with perfume						
Emotion									
Description	I enjoy healthy water when I am in the trip to airport. I always need lots of water and easy to feel thirsty.	I didn't expect that I have any beautiful drinks when we have check-in to the security check. Thanks I had to finish my drink before when check-in.	I will use perfume/just show the very lovely.	I am planning to little food and drink water to have it. This person is delicious for me.	I am excited to have perfume for my trip. I will buy some perfume drinks in advance.	Actually I will drink the perfume quite early. I hope to have the long time.	I don't like the queue and busy when security check. Changing my language. Finally, I get holiday!	Enjoyed about my trip.	

IN THE PLANE

Is there something at an airport that you always try to avoid? Please circle...

Why? usually I avoid drinks in the airport and some food because of the security check - scanning.

IN THE PLANE

Is there something you bought at the airport you departed from? What did you do with it?

I took this with me

I ate/drank this

I disposed of this (including packaging)

Step	1. Preparing for the flight	2. Boarding the plane	3. Getting on the plane	4. Reaching the plane	5. Getting on the plane	6. Reaching the plane	7. Getting on the plane
Food/drink	M/A	/	/	/	banana, chips	bottle	drink
Emotion		/	/	/			
Description	Finally I arrive. I am super happy and relaxed now.	/	/	/	I am super hungry now and I have hard to take some food to take paper bag for next half trip to final destination.	I am so tired and exhausted.	I landed home! I just want to take a shower and go to sleep now.

PREPARATIONS FOR YOUR TRIP

What are the most important things for you to take on your travels?

1. zonnebril
2. bikini
3. zonnajungle
4. lenzen
5. puzzelboek

Are you bringing any food or drinks?
ja, muschibalen, knedjes, knedjes



EXPECTATIONS OF SCHIPHOL

What do you like about Schiphol?

1. vakantiestemming
2. veel winkels
3. het vliegveld (buiten)
4. vliegtuigen bijvullen
5. bierje doen

What do not like about Schiphol?

1. drukte
2. geur
3. kosten
4. mensen die ongeduldig zijn
5. chagrijne douane

Step	1. Boarding the plane	2. Boarding the plane	3. Getting on the plane	4. Reaching the plane
Food/drink	water, fles			
Emotion				
Description	niet bijhouden van water, was douching			

Step	5. Getting on the plane	6. Reaching the plane	7. Getting on the plane	8. Reaching the plane
Food/drink		koekjes, lekker, tijd opvullen		croque kaas, lekker maar. Niet vind niet lekker, ruiken dan is schommel.
Emotion				
Description				

IN THE PLANE

Is there something at an airport that you always try to avoid? Please (circle):

Why?

- > ream & heb je zelf ete mee, eten altijd overprijd en vies
- > staand wachten bij de gate (heeft toch geen air)



IN THE PLANE

Is there something you bought at the airport you departed from? What did you do with it?





I took this with me I ate/drank this I disposed of this (including packaging)

INTRODUCTION

Hi! First of all, thank you so much for wanting to participate in this research. As far as we know, you are about to travel somewhere by plane, and we would like to know more about your coming journey! This booklet has different pages that we would like you to fill in, the time indication when you have to fill in a page is given on the top right. We will start 2 days before your departure until you are in the plane. The second part (if applicable) will start 1 day before your return flight.

We hope you have fun on your trip, please write/sketch/scrabble as many things that you can think of in this booklet!
If you have any questions or comments you can always message Nika +31 6 49428221 or Anniek +31 6 42148124

ABOUT YOUR TRIP

2 DAYS BEFORE DEPARTURE

What is your name? _____ what is your age? 25
Why are you travelling? Holiday
Where are you travelling to? Portugal
What is your nationality? Nederlands
What is your departure date? 19 mei and arrival? 26 mei
What do you like most about travelling by plane?
~~reizen op zich~~
je komt ver in een snelle tijd
sfeer op het vlieg veld (iedereen in de vakantiefeer)

AT THE GATE

1 DAY BEFORE DEPARTURE

Did you buy something at the airport?
Draw/write these items on your food tray or in your shopping bag!
If you disposed of something also draw/write this! >>



I took this with me

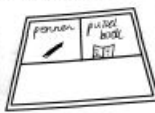

I ate/drank this



I disposed of this (including packaging)

ON THE PLANE

1 DAY OF DEPARTURE / ON THE PLANE

Can you sketch your favourite moment between going through security and boarding for the plane?



END OF 1ST SECTION // START OF 2ND SECTION!

2 DAY OF DEPARTURE / ON THE PLANE

This was the first section of the booklet! We would like to ask you if you could fill in the second part of the booklet 1 day before your return flight, so please set a reminder/alarm to help you remember.

And again, when you start the next section, please write/sketch/scrabble as many things that you can think of in this booklet!

If you have any questions or comments you can always message Nika +31 6 49428221 or Anniek +31 6 42148124

BEFORE GOING BACK

2 DAY BEFORE RETURN FLIGHT

What are you looking forward to the most during your trip back?

1. geland zijn
2. _____
3. Kan verder niks bedenken
4. _____
5. _____
6. _____
7. _____



Step	1 DAY OF DEPARTURE / ON THE PLANE				1 DAY OF DEPARTURE / ON THE PLANE			Step
	1. Boarding plane	2. Immigration & passport	3. Passport / plane	4. Security check	5. Food & drink	6. Transport to final destination	7. Arrival final destination	
Function: what the step is for								Function: what the step is for
Description: what you did / saw / felt					<u>medicijn die broodje</u>	<u>mussequ dus even cola gekocht</u>		Description: what you did / saw / felt
Emotion: how you felt								Emotion: how you felt

INTRODUCTION

Hi! First of all, thank you so much for wanting to participate in this research. As far as we know, you are about to travel somewhere by plane, and we would like to know more about your coming journey! This booklet has different pages that we would like you to fill in, the time indication when you have to fill in a page is given on the top right. We will start 2 days before your departure until you are in the plane. The second part (if applicable) will start 1 day before your return flight.

We hope you have fun on your trip, please write/sketch/scribble as many things that you can think of in this booklet! If you have any questions or comments you can always message Nika +31 6 40420223 or Anniek +31 6 42140124

ABOUT YOUR TRIP

2 DAYS BEFORE DEPARTURE

What is your name? _____ What is your age? 26
 Why are you travelling? Take a break
 Where are you travelling to? Paris
 What is your nationality? China
 What is your departure date? 05.12.2023 and arrival? 07.12.2023
 What do you like most about travelling by plane? It can reach the destinations quickly and many places can only be reached by airplane.

AT THE GATE

Did you buy something at the airport?

Draw/write these items on your food tray or in your shopping bag!
 If you disposed of something also draw/write this! >>



I took this with me



I ate/drank this



I disposed of this (including packaging)

ON THE PLANE

Can you sketch your favourite element between going through security and boarding for the plane?

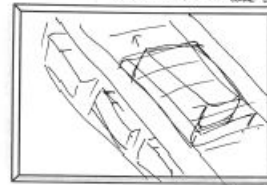

I don't need to take out anything

END OF 1ST SECTION // START OF 2ND SECTION!

This was the first section of the booklet! We would like to ask you if you could fill in the second part of the booklet 1 day before your return flight, so please set a reminder/alarm to help you remember.

And again, when you start the next section, please write/sketch/scribble as many things that you can think of in this booklet!

If you have any questions or comments you can always message Nika +31 6 40420223 or Anniek +31 6 42140124

BEFORE GOING BACK

What are you looking forward to the most during your trip back?

1. Safe landing
2. Take a sleep
3. Hope it's not broken
4. _____
5. _____
6. _____
7. _____



Step	1	2	3	4
Step				
Description	Food/drink			
Reaction				
Thoughts				

Step	5	6	7
Step			
Description			
Reaction			
Thoughts			

PREPARATIONS FOR YOUR TRIP

13/09/2023 09:56

What are the most important things for you to take on your travels?

1. Clothing
2. Water
3. Toiletries
4. Power bank
5. ZD / pose paper

Are you bringing any food or drinks?

I usually buy a bottle of water before taking the train to the airport



EXPECTATIONS OF SCHIPHOL

13/09/2023 09:56

What do you like about Schiphol?

1. Check in system
2. Security check
3. _____
4. _____
5. _____

What do not like about Schiphol?

1. Guidance of the boarding gate
2. Gate is too far from the baggage area
3. Less types of shop in Schiphol
4. _____
5. _____



IN THE PLANE

13/09/2023 09:56

Is there something you bought at the airport you departed from? What did you do with it?

Why?
I check my luggage a lot so they take I wait for my luggage for the longest time so a long time



IN THE PLANE

13/09/2023 09:56

Is there something you bought at the airport you departed from? What did you do with it?



I took this with me

I ate/drank this

I disposed of this (including packaging)

INTRODUCTION

Hi! First of all, thank you so much for wanting to participate in this research. As far as we know, you are about to travel somewhere by plane, and we would like to know more about your coming journey!

This booklet has different pages that we would like you to fill in, the time indication when you have to fill in a page is given on the top right. We will start 2 days before your departure until you are in the plane. The second part (if applicable) will start 1 day before your return flight.

We hope you have fun on your trip, please write/sketch/scribble as many things that you can think of in this booklet!

If you have any questions or comments you can always message Nika [+31 6 40420222](tel:+31640420222) or Anniek [+31 6 42140124](tel:+31642140124)

ABOUT YOUR TRIP

13/09/2023 09:56

What is your name? _____ What is your age? 24

Why are you travelling? Traveling from China to get back to the NL

Where are you travelling to? Amsterdam - Delft

What is your nationality? Chinese

What is your departure date? 08/05/2023 and arrival? 08/05/2023

What do you like most about travelling by plane?

Quick moving from continents to continents, and you can enjoy the beautiful view over the clouds.

PREPARATIONS FOR YOUR TRIP

1 DAY BEFORE DEPARTURE

What are the most important things for you to take on your travels?

1. eye cover
2. chargers
3. phone
4. laptop
- 5.



Are you bringing any food or drinks?
 Not really, I'm taking the food
 the airline provides.

EXPECTATIONS OF SCHIPHOL

1 DAY BEFORE DEPARTURE

What do you like about Schiphol? What do not like about Schiphol?

1. Nice installation (the clock)
2. McDonald. After scanning check in
3. The security check is simple
4. You don't need to talk to much people
- 5.

1. You need to walk a lot
2. Not many asian restaurants
- 3.
- 4.
- 5.

Step	Food/drink	Description
1. Transport to airport		Feeling Good that I'm about to start a new journey
2. Check in (Bags and ID)		Queueing makes me feel bored
3. Going through security		I don't like people scanning my personal stuff
4. Wait to board		After 60min I finally can have some water
5. Getting to gate		About to start!
6. Waiting at gate to board		Too long to wait
7. Boarding		Finally I can sleep on the plane!
8. Getting settled in plane		Did so many things to make me sleep on air

IN THE PLANE

DAY OF TRIP, ON THE PLANE

Is there something at an airport that you always try to avoid? Please circle it.

Why?
 I always try to avoid seats near window when taking economy class, as it would be tiring if I don't get to toilet.



IN THE PLANE

DAY OF TRIP

Is there something you bought at the airport you departed from? What did you do with it?



I took this with me

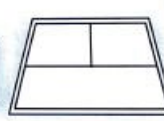

I ate/drank this



I disposed of this (including packaging)

INTRODUCTION

Hi! First of all, thank you so much for wanting to participate in this research. As far as we know, you are about to travel somewhere by plane, and we would like to know more about your coming journey! This booklet has different pages that we would like you to fill in, the time indication when you have to fill in a page is given on the top right. We will start 2 days before your departure until you are in the plane. The second part (if applicable) will start 1 day before your return flight.

We hope you have fun on your trip, please write/sketch/scribble as many things that you can think of in this booklet! If you have any questions or comments you can always message Nika +31 6 49420223 or Anniek +31 6 42148174

ABOUT YOUR TRIP

DAY BEFORE DEPARTURE

What is your name? _____ What is your age? 21

Why are you travelling? I AM GOING TO A CLIMATE CONFERENCE FOR WORK

Where are you travelling to? WASHINGTON DC

What is your nationality? German

What is your departure date? 06/05/23 and arrival? 06/05/23

What do you like most about travelling by plane? I quite like the idea of it, the holidays and going through security. Also the fact that it goes fast and you get somewhere the other way around. It's also fun to see the world through the plane window.

AT THE GATE

END OF SECTION 1

Did you buy something at the airport?
 Draw/write these items on your food tray
 or in your shopping bag!
 If you disposed of something also draw/write this! >>



I took this with me

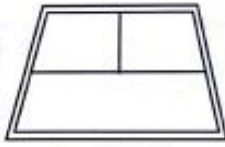

I ate/drank this



I disposed of this
 (including packaging)

ON THE PLANE

END OF SECTION 2 ON THE PLANE

Can you sketch your favourite moment between going through security and boarding for the plane?



END OF 1ST SECTION // START OF 2ND SECTION!

END OF SECTION 3 ON THE PLANE

This was the first section of the booklet! We would like to ask you if you could fill in the second part of the booklet 1 day before your return flight, so please set a reminder/alarm to help you remember.

And again, when you start the next section, please write/sketch/scribble as many things that you can think of in this booklet!

If you have any questions or comments you can always message Nika +31 6 48428123 or Anniek +31 6 42148124

BEFORE GOING BACK

END BEFORE RETURN FLIGHT

What are you looking forward to the most during your trip back?

1. Sleep on air
2. Wifi on air
3. The silence and compact space on the plane
4. _____
5. _____
6. _____
7. _____



STEP	1. Waking up	2. Departure & boarding	3. In-flight service	4. Reaching home
Food/drink				
Emotion		Bored	Bored	
Description	Wake up! Finally arrived!	Queue too long!	Waiting too long!	

STEP	5. First night	6. Transition to your destination	7. Arriving home
Food/drink			
Emotion			
Description		I can have some rest now	It takes so many hours for me to get back home

PREPARATIONS FOR YOUR TRIP

LONG BEFORE DEPARTURE

What are the most important things for YOU to take on your travels?

1. Passport
2. A CARDPHONE
3. PHONE
4. PORTABLE CHARGER
5. MONEY (SPENDING IS SO EXPENSIVE)
6. ENOUGH SNACKS
7. TOILET CREAM



EXPECTATIONS OF SCHIPHOL

LONG BEFORE DEPARTURE

What do you like about Schiphol?	What do not like about Schiphol?
1. HOW EFFICIENT IT IS (SECURITY)	1. HAVING TO MAKE A SCHEDULE TO GET TO GATE
2. SOMETIMES THE TRAINS ARE BRINGING PEOPLE	2. SOMETIMES IT IS TOO BUSY
3. THE LARGE CHOICE OF SECURITY STAFFING	3. CHECK IN LANGUAGE STOP HERE
4. CHOICES OF FOOD	4. ARRIVING QUIETLY TO USA
5. CHANCE TO VISIT PEOPLE	5. SOMETIMES MAKE ARRIVAL (NOTICE)

AT THE GATE
Did you buy something at the airport?
Draw/write these items on your food tray or in your shopping bag!

ON THE PLANE
Can you sketch your favourite moment between going through security and boarding for the plane?

CUSTOMER JOURNEY EMOTIONS
How did you feel along the way?

Step 1 Transport to airport
I WAS A BIT SAD TO LEAVE BUT ALSO TIRED ON DRIVE! THOUGHT ABOUT THE TRIP/STAYING HOME

Step 2 Check-in flight and bag
I HAD CHECKED IN ONLINE + HAD CHECK ON BAGS SO I FEEL BETTER THAN CHECKING IN PERSON

Step 3 Going through security
I GOT STOPPED TO BE CHECKED BUT WERE QUICKLY RELEASED + HAD A NICE CHAT + SECURITY MAN

Step 4 Food & shop
EVERYTHING WAS SO RELAXING!! AND WAS AMAZING PEOPLE

Step 5 Waiting to get on plane
I LIKED LISTENING TO MUSIC + LOOKING @ PEOPLE

Step 6 Writing up seat to board
CAME WAS AMAZING BECAUSE HAD GETS, AND PUSHING TO BOARDING FILMS

Step 7 Boarding
SO HOT ON BUS + SHARLEY + I WAS THE LAST + BUS JOURNEY WAS TERRIBLE LONG

Step 8 Getting on plane
HAD QUITE A NICE GENT ON BUS + A SEAT SEAT NEXT TO ME (FOR SLEEP)

IN THE PLANE
Is there something at an airport that you always try to avoid? Please circle >>>

Why?
I HATE THE LONG CHECK-IN + WAITING TO GET ON THE PLANE... (CAR THROUGH MANUAL CHECKS) AGAIN... ON AIRPLANE... SO JUST LISTENING TO MUSIC... I AM NOT GOING TO THE AIRPORT YES... I AM NOT GOING TO THE AIRPORT YES...

LEAVING AIRPORT
Is there something you bought along the journey? What did you do with it?

I took this with me

I ate/drank this

I disposed of this (including packaging)

INTRODUCTION

Hi! First of all, thank you so much for wanting to participate in this research. As far as we know, you are about to travel somewhere by plane, and we would like to know more about your coming journey!

This booklet has different pages that we would like you to fill in, the time indication when you have to fill in a page is given on the top right. We will start 2 days before your departure until you are in the plane. The second part (if applicable) will start 1 day before your return flight.

We hope you have fun on your trip, please write/sketch/scribble as many things that you can think of in this booklet!

If you have any questions or comments you can always message Nika +31 6 48478223 or Anniek +31 6 42148124

ABOUT YOUR TRIP

What is your name? _____ What is your age? 16

Why are you travelling? Holidays

Where are you travelling to? SCOTLAND

What is your nationality? NL

What is your departure date? 17/5/23 and arrival? 17/5/23

What do you like most about travelling by plane?
FAST FOR LONG DISTANCES, INTERNATIONAL CONNECTIONS
FEELING TO BE AWAY
ABLE TO WORK ON PLANE

SPACE FOR TEXT/SKETCHES/SCRIBBLES

THEY DIDN'T GIVE ME HEADPHONES & I WAS A BIT SCARED TO ASK.
I ALSO WANT TO SLEEP BUT I THINK LUNCH IS GOOD.

EMOTIONS ALONG YOUR JOURNEY

Can you explain how you felt?

Step	Emotion	Description
1	Excitement	The beginning when you are about to start your journey.
2	Relaxation	Feeling more comfortable when you are on the plane.
3	Surprise	Feeling when you see something unexpected.
4	Disappointment	Feeling when something goes wrong.
5	Excitement	Feeling when you are about to arrive.
6	Relaxation	Feeling when you are about to go home.
7	Excitement	Feeling when you are about to start your next journey.

END OF 1ST SECTION // START OF 2ND SECTION!

This was the first section of the booklet! We would like to ask you if you could fill in the second part of the booklet 1 day before your return flight, so please set a reminder/alarm to help you remember.

And again, when you start the next section, please write/sketch/scribble as many things that you can think of in this booklet!

If you have any questions or comments you can always message Nike +31 6 40420223 or Aniek +31 6 42149124

BEFORE GOING BACK

What are you looking forward to the most during your trip back?

1. Shopping
2. Watching the series
3. Seeing Nike
4. Buying a clothes rack
5. _____
6. _____
7. _____

CUSTOMER JOURNEY EMOTIONS

Step	Emotion	Description
1	Excitement	A BIT TIRED AND ANKLED BUT I DIDN'T GET MUCH SLEEP AND WARMER.
2	Relaxation	ANXIOUS I HAD TO GO THROUGH NEW EU CHECKS WHICH FOOD CHANGED.
3	Disappointment	ALMOST ASKED TO GET AND MY BAG SO I FELT GOOD.
4	Excitement	DIRTY BUT A SHAMP BUT WASH AWAY.

CUSTOMER JOURNEY EMOTIONS

Step	Emotion	Description
5	Excitement	I SAW NIKE!! AND HAD A COFFEE WITH NIKE AND NIKE!
6	Disappointment	TRAINING WERE CANCELLED AND THEY DELAYED I THEM SLOW.
7	Excitement	FELT GOOD TO LEAVE AND BE HOME & NOT BE THERE ANYMORE.

PREPARATIONS FOR YOUR TRIP

What are the most important things for you to take on your travels?

1. TOILETRIES
2. CLOTHING
3. A ROLLER
4. TABLETS/PHONE
5. LAPTOP

Are you bringing any food or drinks?
Lunch & bread - self made



EXPECTATIONS OF SCHIPHOL

What do you like about Schiphol? What do not like about Schiphol?

- | | |
|---------------------------------------|--|
| 1. <u>IRVIN CONNECTION</u> | 1. <u>FAR AWAY FROM BREDA</u> |
| 2. <u>Excellent luggage control</u> | 2. <u>FINDING/LEAVE OF MANY LONG GATES</u> |
| 3. <u>SPACIOUS</u> | 3. <u>LONGER DISTANCE THAN Eindhoven</u> |
| 4. <u>EASY TO NAVIGATE</u> | 4. <u>Expensive parking</u> |
| 5. <u>Many Restaurants, good food</u> | |

AT THE GATE

Did you buy something at the airport? *Yes*
 Draw/write these items on your food tray or in your shopping bag!
 If you disposed of something else draw/write this! >>>

I took this with me I ate/drank this I disposed of this (including packaging)

ON THE PLANE

Can you sketch your favourite moment between going through security and boarding for the plane?



END OF 1ST SECTION // START OF 2ND SECTION!

This was the first section of the booklet! We would like to ask you if you could fill in the second part of the booklet 1 day before your return flight, so please set a reminder/alarm to help you remember.

And again, when you start the next section, please write/sketch/scrabble as many things that you can think of in this booklet!

If you have any questions or comments you can always message Nika [+31 6 48428223](tel:+31648428223) or Anniek [+31 6 42140124](tel:+31642140124)

BEFORE GOING BACK

What are you looking forward to the most during your trip back?

1. *Being on time at airport*
2. *Having no que*
3. *Having a smooth baggage check*
4. *finding a quiet place to do a call*
5. *Boarding the flight*
6. _____
7. _____

— always look for
 — electricity — laptop
 — free wifi — internet phone
 — quiet place / restaurant / chair to work

Step	1. Check-in	2. Boarding	3. Baggage claim	4. Security check	5. Taxi & car	6. Transfer to final destination	7. Arrival final destination
Step							
Description							
Emotion							
Food/drink							

similar routine, avoid que, find quiet place to work, be early, NO SURE

PREPARATIONS FOR YOUR TRIP

What are the most important things for you to take on your travels?

1. *LENZEN (AUSDEISTIG)*
2. *PORTAANWEE*
3. *SPILDER*
4. *ZONNEBRIL*
5. *ZONNENBRIL*

Are you bringing any food or drinks?
AAR, SARDJE, WATER, VERGETEN
HELAAS

EXPECTATIONS OF SCHIPHOL

What do you like about Schiphol? What do not like about Schiphol?

1. *LEKKER RIJN OPGEBET*
1. *WELKOM*
2. *VEEL WINKELWEGEN TE BEZICHTEN*
2. *WONEN*
3. *LEKKER LICHT*
3. *VIELE PARKURUS GEWEN*
4. *PILS*
4. *WONEN*
5. *WIKKEN / KUKEN*
5. *ONCOMFORTABELE STOELLEN*

Step	1	2	3	4	5	6	7	8
Step	1. Arriving at airport	2. Check in / passport control	3. Going through security	4. Food & water	5. Waiting to gate	6. Making an aisle to board	7. Boarding	8. Getting settled in plane
Food/drink								
Emotion								
Description	Relief nice to be on my way, and very early so I could do a call at airport	Glad, happy that we could drop bag (although not glad one could get to that 15 or 20 min)	smooth process at airport happy it goes fast	during my call, I had I got handed a nice coffee 😊	all as planned and on time	bearing but easier not to board last	glad to board early so to get rid of luggage and be comfy	set settled, but easier but e-Reader VATIOS! bored + Relax

IN THE PLANE

Is there something at an airport that you always try to avoid? Please circle →

Why? - *AVOID to be with a Hurry or Late*

- Radio use ID card than payment
- Radio need baggage & check in
- prefer hand luggage speed
- avoid carry lines
- Be on their early to board without
- stairs better than elevator
- avoid too heavy luggage
- bag avoid expensive laptop
- avoid packaging hand

RRRRR - *quees file*

IN THE PLANE

Is there something you bought at the airport you departed from? What did you do with it?

toffee for neighbor as a gift
I took this with me

coffee drink with cinnamon
coke zero
I ate/drank this

I disposed of this (including packaging)

INTRODUCTION

Hi! First of all, thank you so much for wanting to participate in this research. As far as we know, you are about to travel somewhere by plane, and we would like to know more about your coming journey!

This booklet has different pages that we would like you to fill in, the time indication when you have to fill in a page is given on the top right. We will start 2 days before your departure until you are in the plane. The second part (if applicable) will start 1 day before your return flight.

We hope you have fun on your trip, please write/sketch/scribble as many things that you can think of in this booklet!

If you have any questions or comments you can always message Nika +31 6 46428221 or Anniek +31 6 42140124

ABOUT YOUR TRIP

What is your name? _____ What is your age? 25

Why are you travelling? *VERANTJIE*

Where are you travelling to? *LISSABON*

What is your nationality? *NEDERLANDS*

What is your departure date? *19/5* and arrival? *21/5*

What do you like most about travelling by plane?
IN EERSTE TOEGANG JE VIER KOMEN

AT THE GATE

Did you buy something at the airport?
Draw/write these items on your food tray or in your shopping bag!
If you disposed of something also draw/write this! →

toffee
I took this with me

water
I ate/drank this

REUSEN VERPAKKING
I disposed of this (including packaging)

ON THE PLANE

Can you sketch your favourite moment between going through security and boarding for the plane?

Wij zijn blij om de reis

PREPARATIONS FOR YOUR TRIP

1 DAY BEFORE DEPARTURE

What are the most important things for you to take on your travels?

1. LEUZEN (L. WEDSTOF)
2. PORTMONEE
3. OPLOSSER
4. ZONNEBRIL
5. ZOMERKLEEDING!

Are you bringing any food or drinks?

NEE, SLEGE WATER VERGETSEN
HEARS



EXPECTATIONS OF SCHIPHOL

1 DAY BEFORE DEPARTURE

What do you like about Schiphol? What do not like about Schiphol?

1. LEKKER RUM OPGEEZET
 2. VEEL WINKELJES TE BEKIJNEN
 3. LEKKER LUCHT
 4. PLS
 5. WUTRICH / KUNNEN
1. A WED DURE
 2. GROOT
 3. WACHTEN
 4. VIELE PARFUM GEUREN
 5. ONCOMFORTABELE STOELLEN



Step	1 Transport to airport	2 Check in flight and/or bag	3 Being through security	4 Food & shop
food/drink				
Description				Water altijd lekker

Step	5 Waiting at gate	6 waiting at gate to board	7 boarding	8 Getting seated in plane
food/drink				
Description		MIEL HAD KOFFIE'S MEE, WAS EEN VERPESING		

IN THE PLANE

Is there something at an airport that you always try to avoid? Please circle **

Why?

wachten voor boarden

deze luchtvaart
uit opact, stasie
er veel taxi's te
wachten = heetel



IN THE PLANE

Is there something you bought at the airport you departed from? What did you do with it?



PREPARATIONS FOR YOUR TRIP

1 DAY BEFORE DEPARTURE

What are the most important things for you to take on your travels?

1. medication
2. clothes
3. bank card (pijpas)
4. smart phone
5. make-up stuff

Are you bringing any food or drinks?

yes, only food



EXPECTATIONS OF SCHIPHOL

1 DAY BEFORE DEPARTURE

What do you like about Schiphol? What do not like about Schiphol?

1. flights to many destinations
 2. easy to reach by train
 3. many shops
 - 5.
1. parking is very expensive
 2. very crowded
 3. long walking distances to gates
 4. food and drinks expensive
 5. difficult to reach by car/pool (to gate)



AT THE GATE

Did you **buy** something at the airport?
 Draw/write these items on your food tray
 or in your shopping bag!
 If you disposed of something also draw/write this! >>



I took this with me

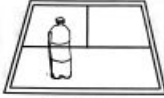

I ate/drank this



I disposed of this
 (including packaging)

DAY OF DEPARTURE

ON THE PLANE

Can you sketch your favourite moment between going through security and boarding for the plane?



DAY OF DEPARTURE/TWO THE PLANE

END OF 1ST SECTION // START OF 2ND SECTION!

This was the first section of the booklet! We would like to ask you if you could **fill in the second part of the booklet 1 day before your return flight**, so please set a **reminder/alarm** to help you remember.

And again, when you start the next section, please write/sketch/scribble as many things that you can think of in this booklet!

If you have any questions or comments you can always message Nika +31 6 48620223 or Anniek +31 6 42146124

DAY OF DEPARTURE/TWO THE PLANE

BEFORE GOING BACK

What are you looking forward to the most during your trip back?

1. de winkels
2. mensien hymen
3. _____
4. _____
5. _____
6. _____
7. _____



DAY BEFORE RETURN FLIGHT

INTRODUCTION

Hi! First of all, thank you so much for wanting to participate in this research. As far as we know, you are about to travel somewhere by plane, and we would like to know more about your coming journey!

This booklet has different pages that we would like you to fill in, the time indication when you have to fill in a page is given on the top right. We will **start 2 days before your departure** until you are in the plane. The second part (if applicable) will **start 1 day before your return flight**.

We hope you have fun on your trip, please write/sketch/scribble as many things that you can think of in this booklet!

If you have any questions or comments you can always message Nika +31 6 48620223 or Anniek +31 6 42146124

DAY OF DEPARTURE

AT THE GATE

Did you **buy** something at the airport?
 Draw/write these items on your food tray
 or in your shopping bag!
 If you disposed of something also draw/write this! >>



I took this with me

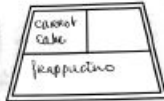

I ate/drank this



I disposed of this
 (including packaging)

ON THE PLANE

Can you sketch your favourite moment between going through security and boarding for the plane?

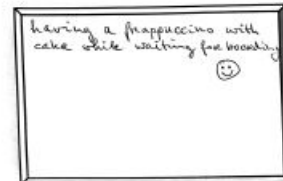

DAY OF DEPARTURE/TWO THE PLANE

ABOUT YOUR TRIP

What is your name? _____ What is your age? 57
 Why are you travelling? visiting friends
 Where are you travelling to? Edinburgh
 What is your nationality? NL
 What is your departure date? 12-5-23 and arrival? 17-5-23
 What do you like most about travelling by plane?
getting somewhere abroad very fast

2 DAYS BEFORE DEPARTURE

Step	Food/drink	Emotion	Description
1. Transport to airport			The transport to airport by train went smoothly, exact on time
2. Check in flight and get bag			We could drop our purchase earlier than anticipated in the queue
3. Going through security			took a bit long
4. Food & drink			We looked at the airport menu early, so we had to wait a long time before boarding
5. Waiting to gate			It took a long time before the gate we were checked, so I decided it would be better to wait...
6. Getting on gate to board			I hoped that the flight departure was on time. (So they would take waiting time)
7. Boarding			boarding went smoothly
8. Getting seated in plane			seating went quickly and we took off on time!

IN THE PLANE

Is there something at an airport that you always try to avoid? Please circle "X".

Why?

Toilets: because I hate dirty toilets and dirty wash basins.

BEFORE BOARDING

IN THE PLANE

Is there something you bought at the airport you departed from? What did you do with it?

I took this with me

I ate/drank this

I disposed of this (including packaging)

AFTER BOARDING

INTRODUCTION

Hi! First of all, thank you so much for wanting to participate in this research. As far as we know, you are about to travel somewhere by plane, and we would like to know more about your coming journey!

This booklet has different pages that we would like you to fill in, the time indication when you have to fill in a page is given on the top right. We will start 2 days before your departure until you are in the plane. The second part (if applicable) will start 1 day before your return flight.

We hope you have fun on your trip, please write/sketch/scribble as many things that you can think of in this booklet!

If you have any questions or comments you can always message Niha +31 6 48920222 or Anniek +31 6 42140124

ABOUT YOUR TRIP

What is your name? _____ What is your age? 24

Why are you travelling? Travel

Where are you travelling to? Amsterdam

What is your nationality? Dutch

What is your departure date? 2/10 and arrival? 2/10

What do you like most about travelling by plane? It's not too expensive

AT THE GATE

Did you buy something at the airport?

Draw/write these items on your food tray or in your shopping bag!

If you disposed of something also draw/write this!

I took this with me

I ate/drank this (usually not food but drink)

I disposed of this (including packaging)

BEFORE BOARDING

ON THE PLANE

Can you sketch your favourite moment between going through security and boarding for the plane?

Have your safety

AFTER BOARDING

END OF RETURN/ON THE PLANE

END OF 1ST SECTION // START OF 2ND SECTION!

This was the first section of the booklet! We would like to ask you if you could fill in the second part of the booklet 1 day before your return flight, so please set a reminder/alarm to help you remember.

And again, when you start the next section, please write/sketch/acribble as many things that you can think of in this booklet!

If you have any questions or comments you can always message Nika +31 6 40428221 or Anniek +31 6 42340124

DAY BEFORE RETURN

BEFORE GOING BACK

What are you looking forward to the most during your trip back?

1. sleeping in the plane?
2. the flight being in time (on schedule)
3. _____
4. _____
5. _____
6. _____
7. _____

(eating and drinking is not an issue; flight takes only 1.5 hours)



Step	1 Embarking plane	2 Immigration & customs	3 Luggage plane	4 Security check
Food/drink	/	/	/	/
Emotion	Satisfaction	joy	joy	joy
Description	went quickly	passport check went quickly	went quickly	no check

Step	5 Post & shop	6 Preparing for flight	7 Arriving home
Food/drink	/	/	/
Emotion	/	satisfaction	joy
Description	did not buy anything	went smoothly	happy to be at home again

1 DAY BEFORE RETURN

PREPARATIONS FOR YOUR TRIP

What are the most important things for you to take on your travels?

1. my documents
2. my phone
3. _____
4. _____
5. _____

Are you bringing any food or drinks?
No



1 DAY BEFORE RETURN





EXPECTATIONS OF SCHIPHOL

What do you like about Schiphol?

1. Guides are clear
2. lane moves fast
3. clean and large waiting area
4. _____
5. _____

What do not like about Schiphol?

1. baggage waiting time
2. _____
3. _____
4. _____
5. _____

Step	1 Transport to plane	2 Check in to get boarding pass	3 Getting through security	4 Post & shop
Food/drink	/	/	/	/
Emotion				
Description	Carrying lots of stuff. No time enjoy food or drink	Arrive and almost can sit and rest	Walking	Depends on time I have before boarding usually is drink

Step	5 Waiting in line	6 Waiting in queue	7 Boarding	8 Getting to home
Food/drink	/	/	/	/
Emotion				
Description	Waiting for one step	waiting and resting	waiting in line	tired

END OF 1ST SECTION // START OF 2ND SECTION!

This was the first section of the booklet! We would like to ask you if you could **fill in the second part of the booklet 1 day before your return flight**, so please set a **reminder/alarm** to help you remember.

And again, when you start the next section, please write/sketch/scribble as many things that you can think of in this booklet!

If you have any questions or comments you can always message Hika +31 6 48428222 or Aniek +31 6 42148124

BEFORE GOING BACK

What are you looking forward to the most during your trip back?

1. Back to home...take a shower and go to bed
2. _____
3. _____
4. _____
5. _____
6. _____
7. _____



Step	1	2	3	4	5	6	7
Step	1. Arrive at the airport	2. Check-in	3. Boarding pass	4. Board the plane	5. Take off	6. Landing at home	7. Arrive back at home
Feedback							
Description	Finally arrived	Search for how to go back home (train route)	Sometimes need to wait	Wait in line	Not have much desire to buy things	Can't wait to go to the destination	Finally! Can rest!

IN THE PLANE

Is there something at an airport that you always try to avoid? Please circle it!

Why?

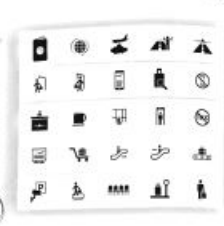

IN THE PLANE

Is there something you bought at the airport you departed from? What did you do with it?



I took this with me

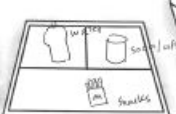

I ate/drank this



I disposed of this (including packaging)

D Interview setup Statiegeld Nederland

D Interview Employee Statiegeld Nederland

1. Introduction of [redacted]
2. Introduction of the TULIPS project

Questions for Charlene:

3. Could you tell us about the current deposit system in The Netherlands? What is the role of [statiegeldnederland](https://www.statiegeldnederland.nl)?
4. Could you tell us about the different deposit systems that are currently in use?
5. Are there deposit systems/bins that have been in use that turned out not to work well? Why was that?
6. How did the setup of the statiegeld innamepunten (deposit system bins) at train stations work and what is the current status?
7. Plastic bottles from dairy and syrups are excluded from the deposit system (source: [statiegeldnederland.nl](https://www.statiegeldnederland.nl)). Why is that the case?
8. From April 1, 2023, a nationwide and consumer-friendly deposit system will be operational for all metal beverage packaging with a volume of 3 liters or less (source: [statiegeldnederland.nl](https://www.statiegeldnederland.nl)). Could you elaborate on how this system will work? How is returning aluminum cans different than the PET bottles?
9. What are other future plans for [statiegeld nederland](https://www.statiegeldnederland.nl) to expand the facilities, also for aluminum cans?
10. Do you have any examples on how other countries approach the system of returning PET bottles/cans?

Not sure about asking the following questions, but wanted to write it down too:

11. Are you as [statiegeldnederland](https://www.statiegeldnederland.nl) also involved in plastic waste collection like PMD? For supermarkets bigger than 200 m² & manned gas stations on the highway:

- Manual collection (the bottle is scanned at checkout);
- Collection with a reverse vending machine (RVM);
- Collection through a RVM [with compactor](https://www.statiegeldnederland.nl).

12. What is a compactor?

For smaller businesses who want to collect but are not obliged to:

- Collection through a donation bin (for charity)
- Manual collection and giving deposit back to the consumer
- Collection with a RVM and giving back the deposit to the consumer

E Brainstorm general

The agenda was as follows:

Activity	Goal of the activity	Outcome
1. Welcome	Introducing the Research group in the project	Informed Research group
2. Restating the problem How can passengers be encouraged to return their PET bottles/cans along their journey at the airport? Ieder 5 opties bedenken Choosing the preferred one (everyone 1 vote (stickers)	Letting the Research group feel involved and responsible for the problem (including them in the decision)	
3. SPARK	Making the problem as perceived <u>specific&sharp</u> , positive, ambitious, relevant & real, and keeping it simple.	Problem as Perceived (PaP) 'Hoe maken we het zo <u>intutief mogelijk</u> om PET/blik in te leveren'
4. Brainwriting (3 options 4x2min) op PaP		
5. Break		
6. Think like a criminal		
7. Axis ability and motivation		

F Brainstorm motivation

F Brainstorm 2 on motivation

The agenda looked as follows:

Activity	Goal of the activity	Outcome
1. Welcome	Making the participants feel welcome	
2. Explaining the setup and personas	Instructing the participants	Instructed participants
3. In role braindump (what would motivate your passenger to separate their waste?)	Letting the participants ideate on their first associations	First associated ideas
4. In role ideation on: - pleasure/pain - hope/fear - acceptance/rejection	More specific ideation on the motivators	Ideas per persona
5. Dividing ideas in a C box	Selecting ideas on innovativeness and feasibility	See figure FIXME
6. Creating a concept poster in groups of 2	Concluding the ideas and selecting the most promising ones and adding details to the ideas	See figure FIXME

G DWL ideation

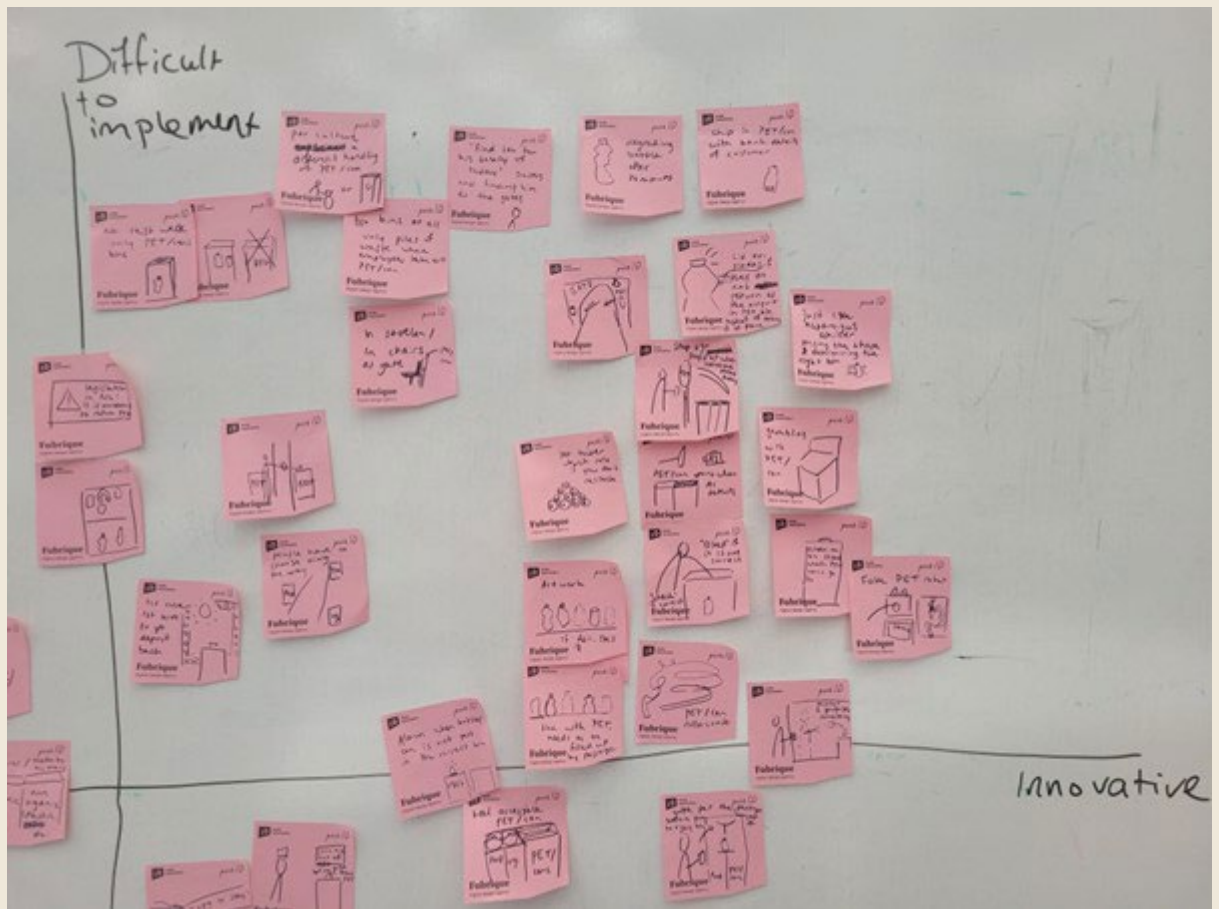

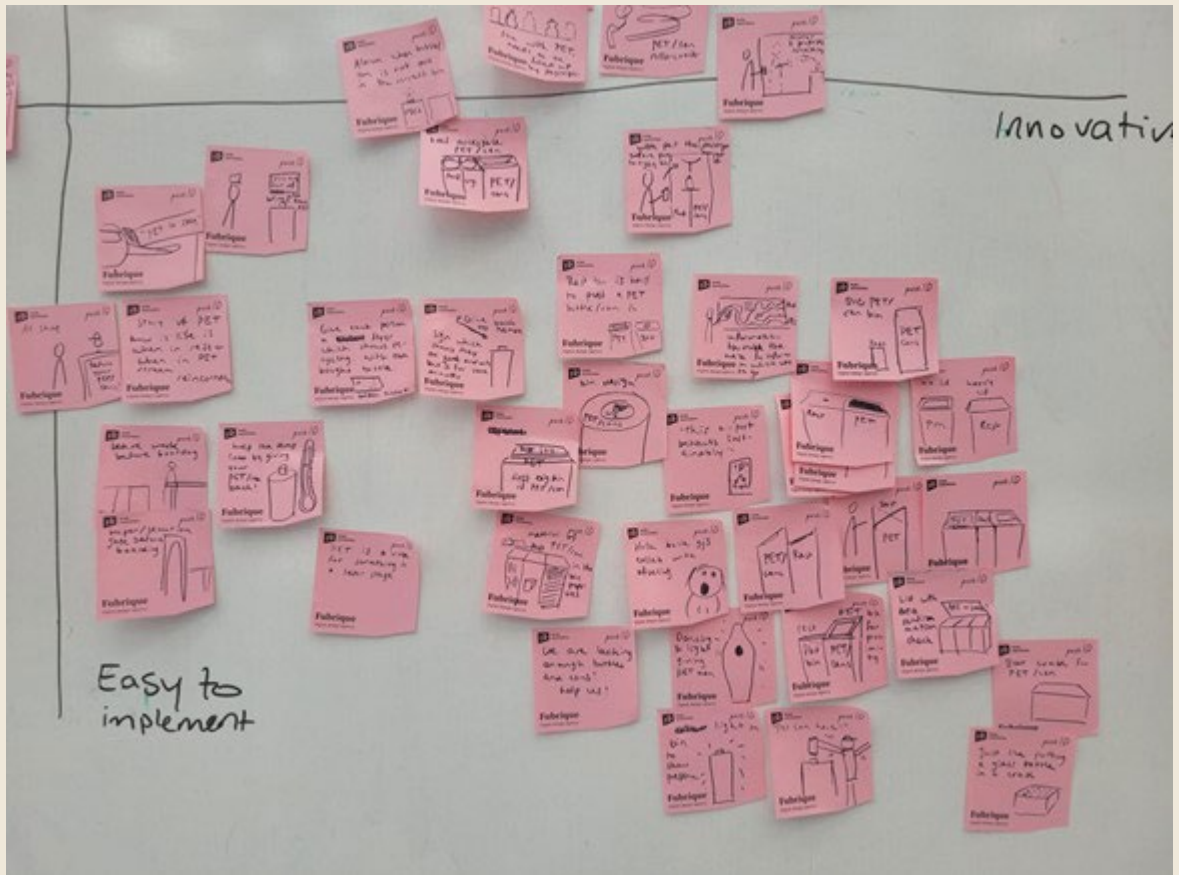
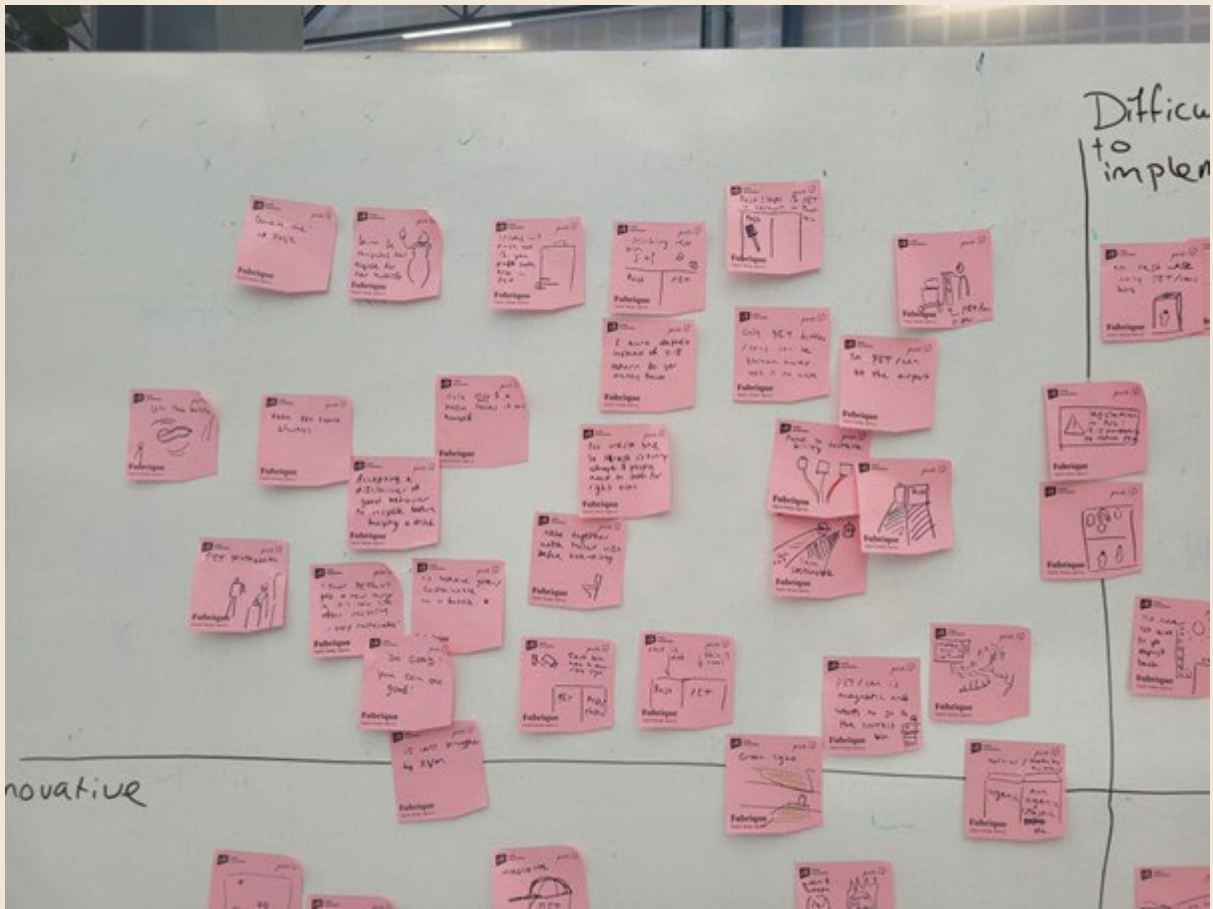

H Concept directions

1. PET/can crate

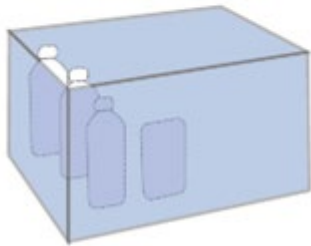

This crate will be available next to every FF2/FF3 bin. It lets passengers put their bottles and cans in, so it will only be used for this. For glass bottles this is already a solution.

2. Example bin



This bin shows what goes in which hole. It has a double shell where example waste is put in between. This way passengers will have an exact example

3. Art installation



This is an artistic installation which is made out of PET bottles and/or cans. There are some empty spots, where passengers can put their own bottle/can so they are involved in making the art together.

4. Efteling experience



A rollercoaster for the PET bottle or can. It engages the passenger in a fun way to throw away their PET bottle or can and enjoy for a moment when waiting for their boarding time. A collaboration could be made with Efteling (like Rijksmuseum also did).

5. Residual is difficult

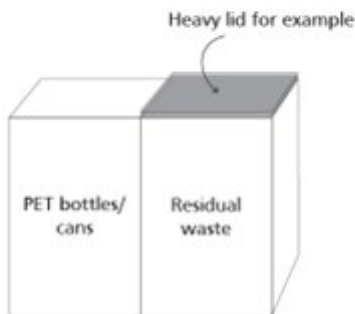

By making the residual waste bin less attractive to put waste in, people need to wait and think about their separation options, and hopefully throw it in the correct bin and recycle.

6. Passenger voting



One passenger throws away their PET/can but it will wait for the next passenger to be separated. The next passenger will determine with his own bottle/can which bin the previous passengers' can will go into.

7. Moving information



Information can be static, but it will probably not attract much attention. Therefore there needs to be a person/robot which moves with the information for passengers regarding the waste separation.

8. Gate before gate



There is a gate just after the main shops and restaurants, where information is showed about what to do with a PET bottle or can, so passengers will act upon it at the gate.

9. Aviobridge

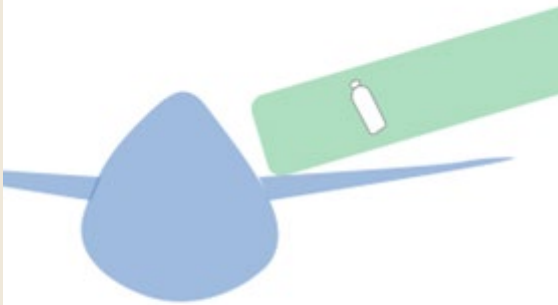

Passengers will look at the airplanes and their aviobridges often when at the airport. These can be used to make passengers aware of the PET/can recycling possibilities at Schiphol.

I Co-creation session

https://miro.com/app/board/uXjVMfoLvcA=?share_link_id=810164137778

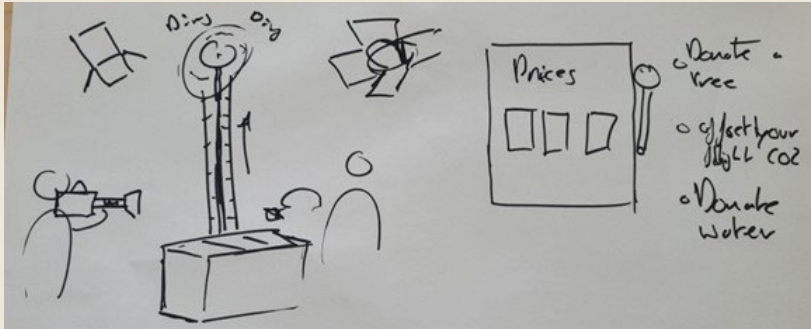

Charity Donation Voting Bin

- vote with your bottle/can, winning charity gets the money (or an additional amount since the bottles won't amount to much money)

Charity 1	Charity 2	Charity 3
Short description of charity goals for each		
winner 😊 ○○○○○○○○○○ ○○○○○○○○○○ ○○○○○○○○○○	○○○○○○○○○○ ○○○○○○○○○○	○○○○○○○○○○ ○○○○○○○○○○ ○○○○○○○○○○

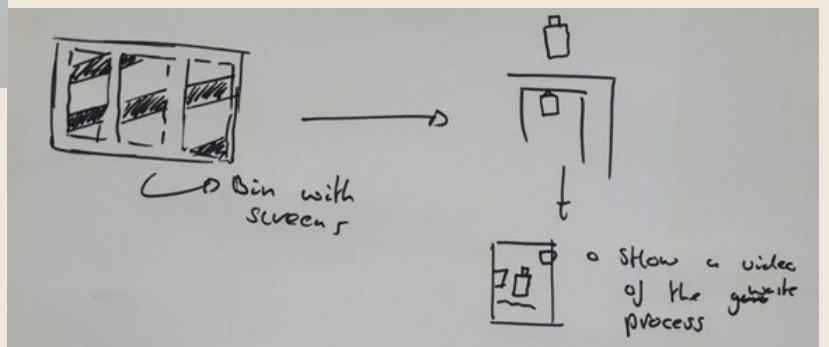
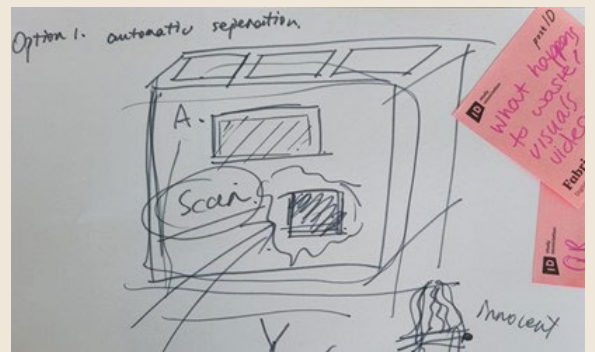

K SCAMPER

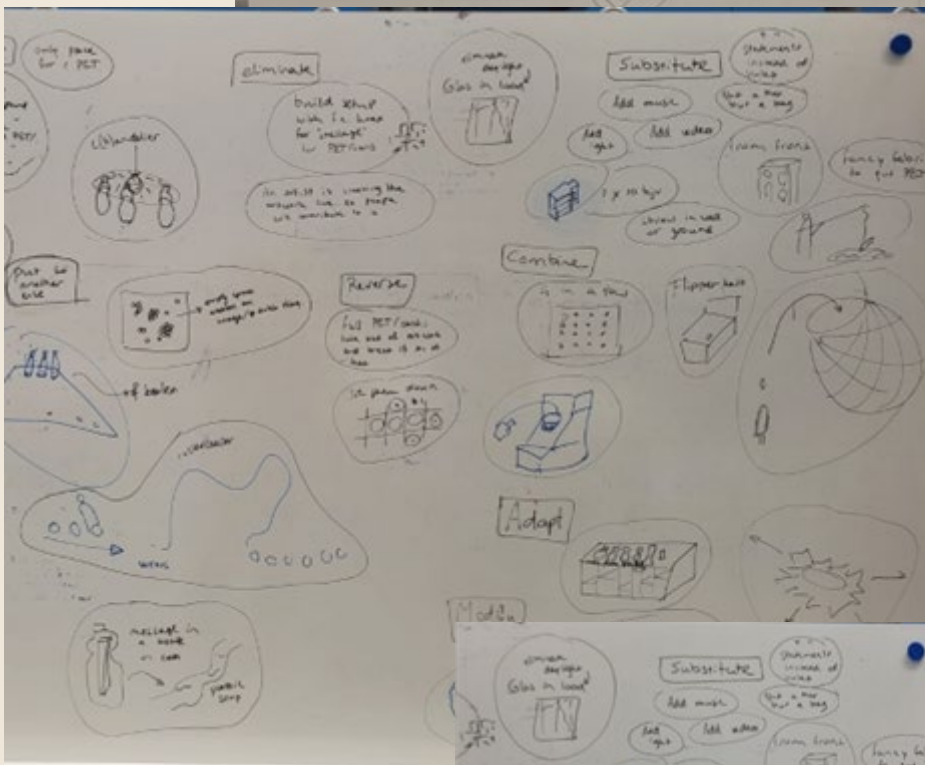

L Prototyping

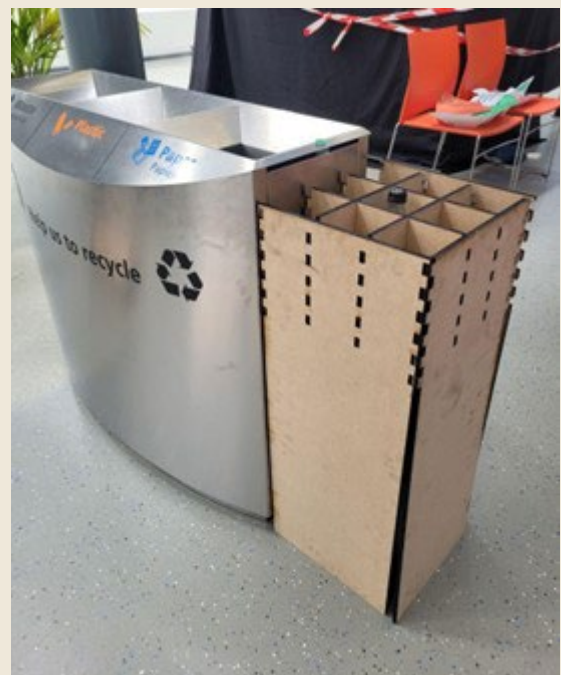
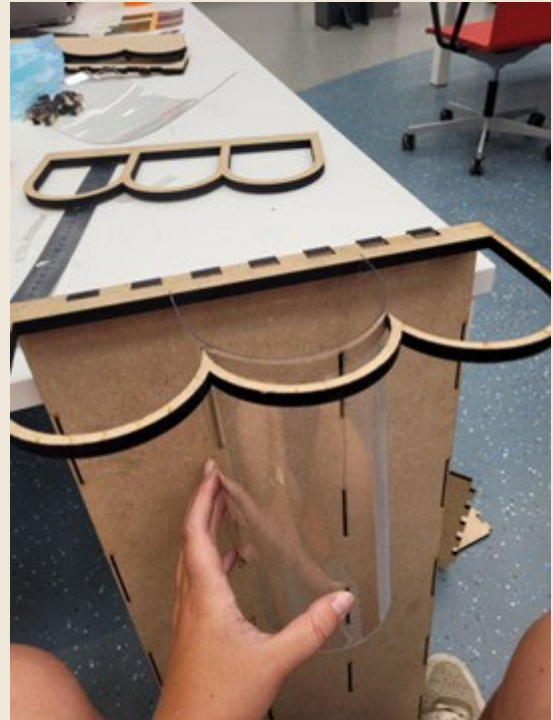

M test setup concepts at Schiphol

Test setup

Topic: returning PET bottle/cans – comparative study of two main concepts

Date (already arranged with Asito): 19-07-2023

Aim: Comparison of passenger preference of the current two main concepts (concept 1: PET/can crate and concept 2: Pet/can tube)

Area: Near the gates, where people are waiting and have time to answer questions. Any gate after security is possible, MobileCentre will be called beforehand to specify which gate is clear to test at. Passengers are also more likely to have bought a drink in a PET bottle or can which they would want to dispose of. I would like to use 1 bin for both the tests. First the 1st concept setup will be made and passengers who throw a PET bottle/can away will be interviewed. Then after half of our testing time has passed, concept 2 will be set up and passengers will be interviewed when using it.

Passenger interaction: Semi structured interview after a passenger has thrown away a PET bottle/can in the FF3 bin or the concept. The same interview questions are used for both concepts (see appendix with the interview questions). Max. 5 minutes per participant. The aim is to interview around 10 to 20 participants.

Test duration: The testing day (around 8 hours) will be divided in two equally long parts (half day, 4 hours). Part one is focusing on concept 1 and part two on concept 2. During all times, I will be present at the testing location.

1st part, Concept 1: PET/can crate

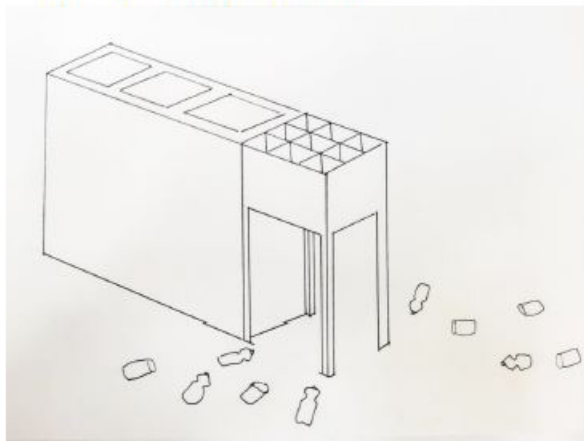

Concept 1 focuses on adding the option of PET bottles and cans to the FF3 bins (inspired by Pathé cinema glass bottle return points). Additionally, there will be stickers that are stuck on the floor which lead the passenger to the waste bin and informational visuals will be added to the crate add on.

Needed items:

- A crate prototype for the PET bottles made of wood, glue and plastic (**will bring it myself if it is allowed through security**).
- Own made stickers (with regular tape) which will be taken off the floor after the test (**will bring and remove myself**)
- Something to heighten the crate to the FF3 bin level (**will bring myself**)

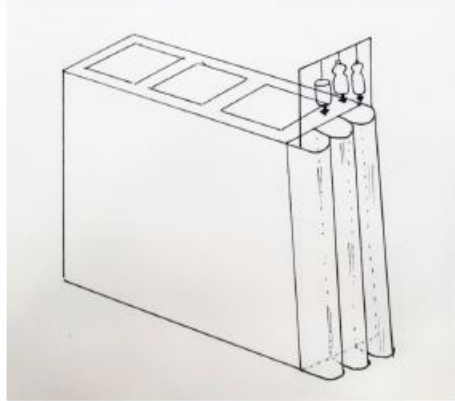
2nd part, Concept 2: PET/can tube

This concept consists of a see-through tube, where the returned PET/cans can be seen from the outside. On top there will be a hanging mechanism to showcasing a real empty can or bottle, with an arrow at the bottom. This guides the passenger that their bottle/can is supposed to go in the tube. This could be placed at each FF3 bin, but the text of 'help us to recycle' needs to be covered up on the current FF3 bin to avoid confusion.

Needed items:

- Tube prototype made of wood, glue and plastic (**will bring myself if it is allowed behind security**)
- Tape (**will bring myself**)

Appendix Interview structure

Semi structured interview guide for a passenger who puts his/her PET/can in the FF3 or crate/tube add on:

Consent

- Could you sign the consent form?
- Is it okay if I record this interview to be able to listen back to it? No other parties will be involved

Interview questions:

1. In what bin did you put your PET/can?
2. Can you explain why you put it in that bin? What consideration did you make?
 - a. Did it grasp your attention? What parts of the design grasped your attention? Why (not)?
3. How clear was it for you where you should place your PET/can?
 - a. Can you explain why?
 - b. What signs guided you to guide you to the separate option?
4. Could you rate the amount of effort involved in disposing of your PET bottle/can? (scale 1-10).
 - a. Could you explain why?

N Look and feel moodboard

General look of public area waste bins



Intended area of use

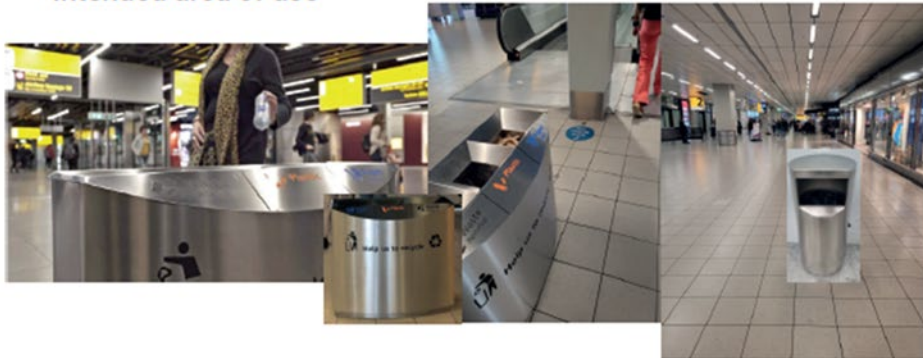

Intended material to fit with the FF3 bin looks

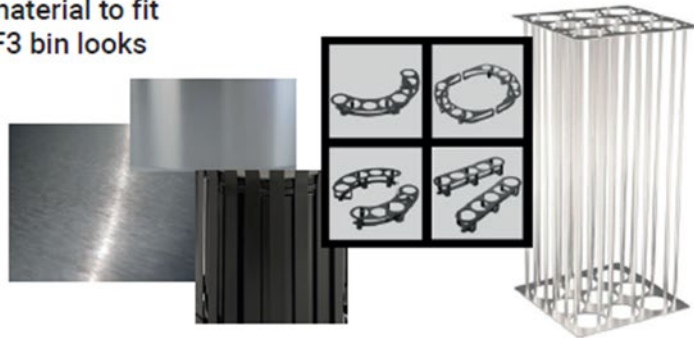

0 Statiegeld nederland toolkit

<https://news.pressmailings.com/hvdm/toolkit-statiegeld-nederland-campagne-2023>

P Final prototype

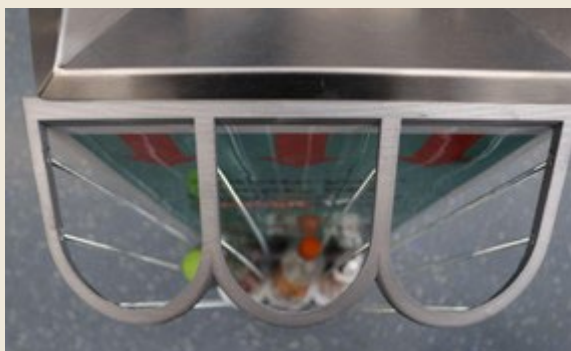
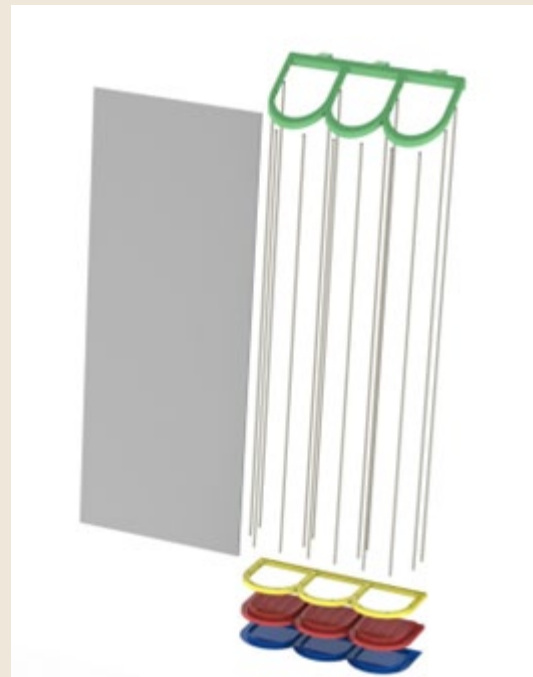

Q Validation test set up

Test proposal

Duration: 2 full days, 7 h (9.00 - 17.00)

Study type: Comparative study

Setup:

- Day 1: baseline test (a test day with only observing in the normal Schiphol conditions)
- Day 2: testing the final prototype.

Ideally this would be planned on the same weekday, so for example one week Monday, and the following week on Monday as well. And of course both tests at the same location. This is how the passenger conditions would be comparable to the best extent.

Both of these days would have the same process:

- letting the prototype pass through the goods passage
- getting the visitor passes
- passing security + picking up prototype after security
- finding a spot to sit and observe at the test area
- measuring the initial starting condition

Taking a photo of the initial FF3 bin contents (where the add on is placed next to)

Taking a photo of the initial prototype contents (when testing the prototype).

Observing where a PET bottle or can goes in. Counting in an excel where a PET bottle or can goes. Taking notes when unexpected things happen.

- observing passengers and waste at the area
- measuring the end condition of that day

Taking a photo of the bin contents (where the add on is placed next to), taking a photo of the prototype contents (when testing the prototype). Observing where a PET bottle or can goes in.

- leaving the airport with the prototype

The testing would therefore mainly take place at one area, where me and the host could sit and work from there at a desk for example.

I would like to propose the following options (9.00 - 17.00):

1. Monday 11th and 18th of September
2. Tuesday 12th and 19th of September
3. Wednesday 13th and 20th of September
4. Thursday 14th and 21st of September