

A
Living
Lab
for
Flow

An architectural meta exploration on the optimal mental state for well-being

Welcome

A public presentation
predicated on
designing for flow
or an attempt at
evidence based design
in the field of architecture

Rohan Shenoy (5238781)

P5
Explore Lab 33
TU Delft Faculty of Architecture

Mentors

Ir. Roel van de Pas
Ir. HL van der Meel
Dr. Ir. Elise van Dooren

Tutors

Dr. Ir. Sabina Tanović

2 November 2022



Origins of Fascination



Stuttgart, Germany, 2000

Origins of Fascination

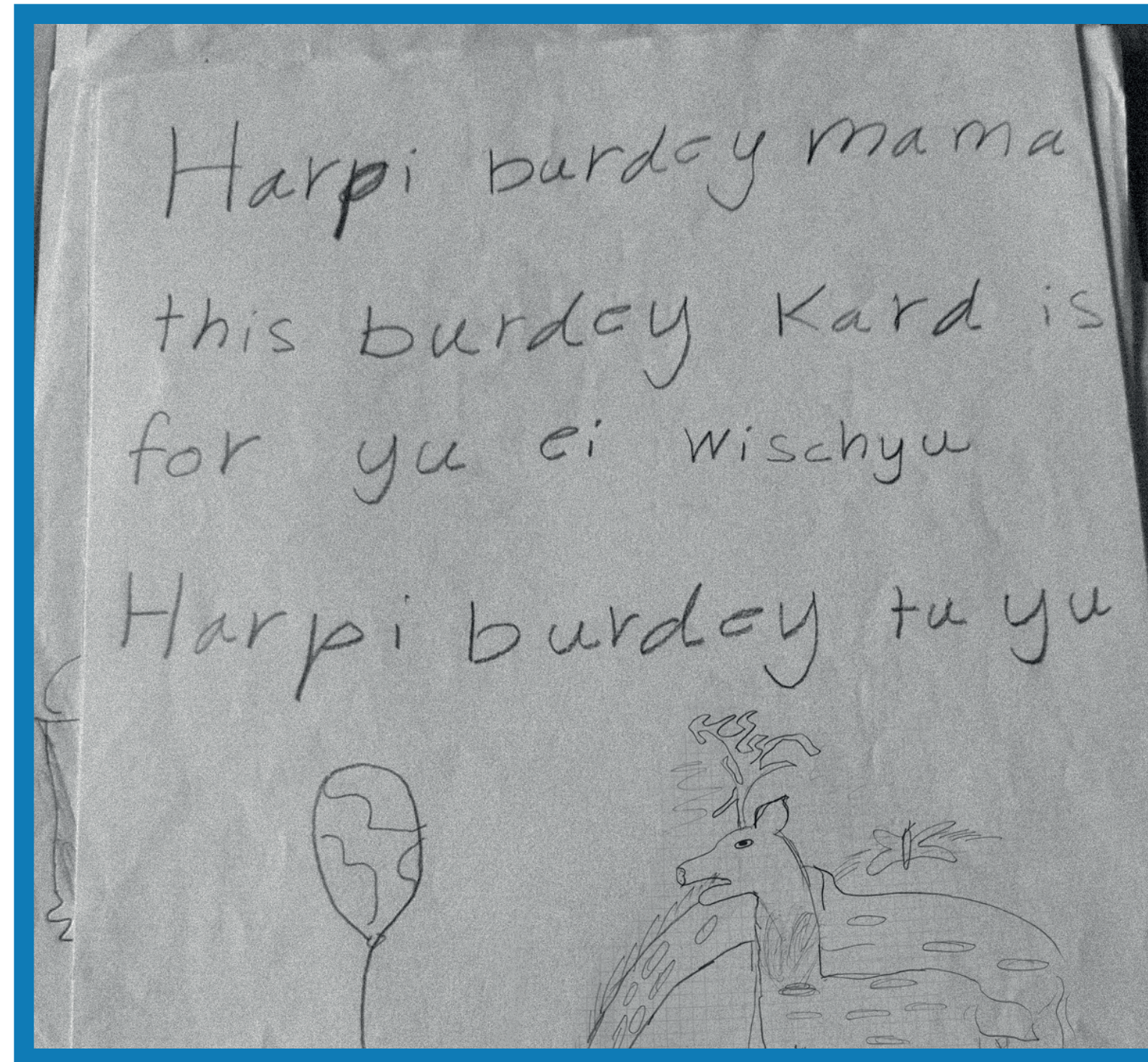

Bangalore, India, 2002

Origins of Fascination

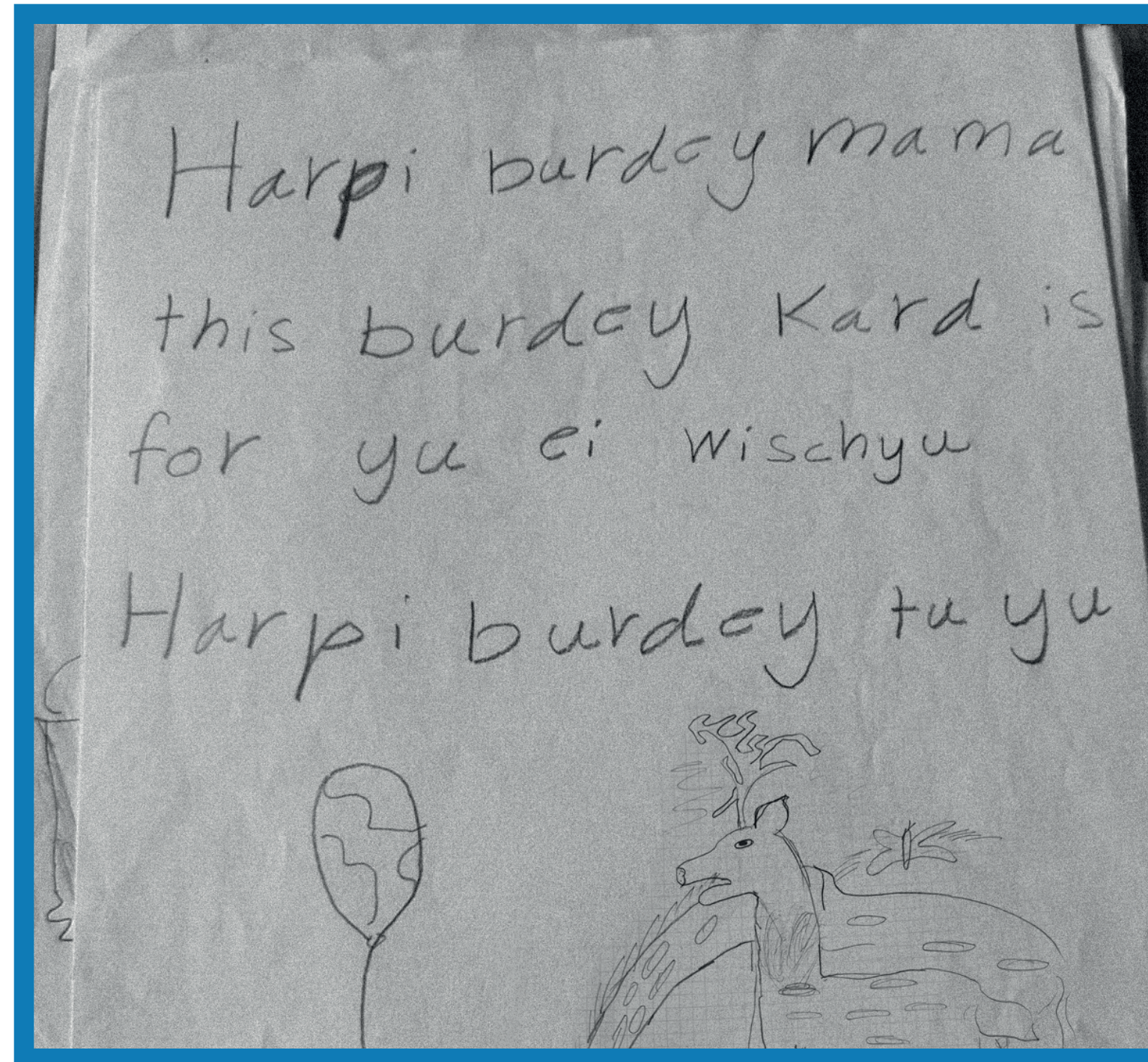

Bangalore, India, 2002

(Happy birthday Mama,
This birthday card is for you.
I wish you happy birthday to you.)

Origins of Fascination

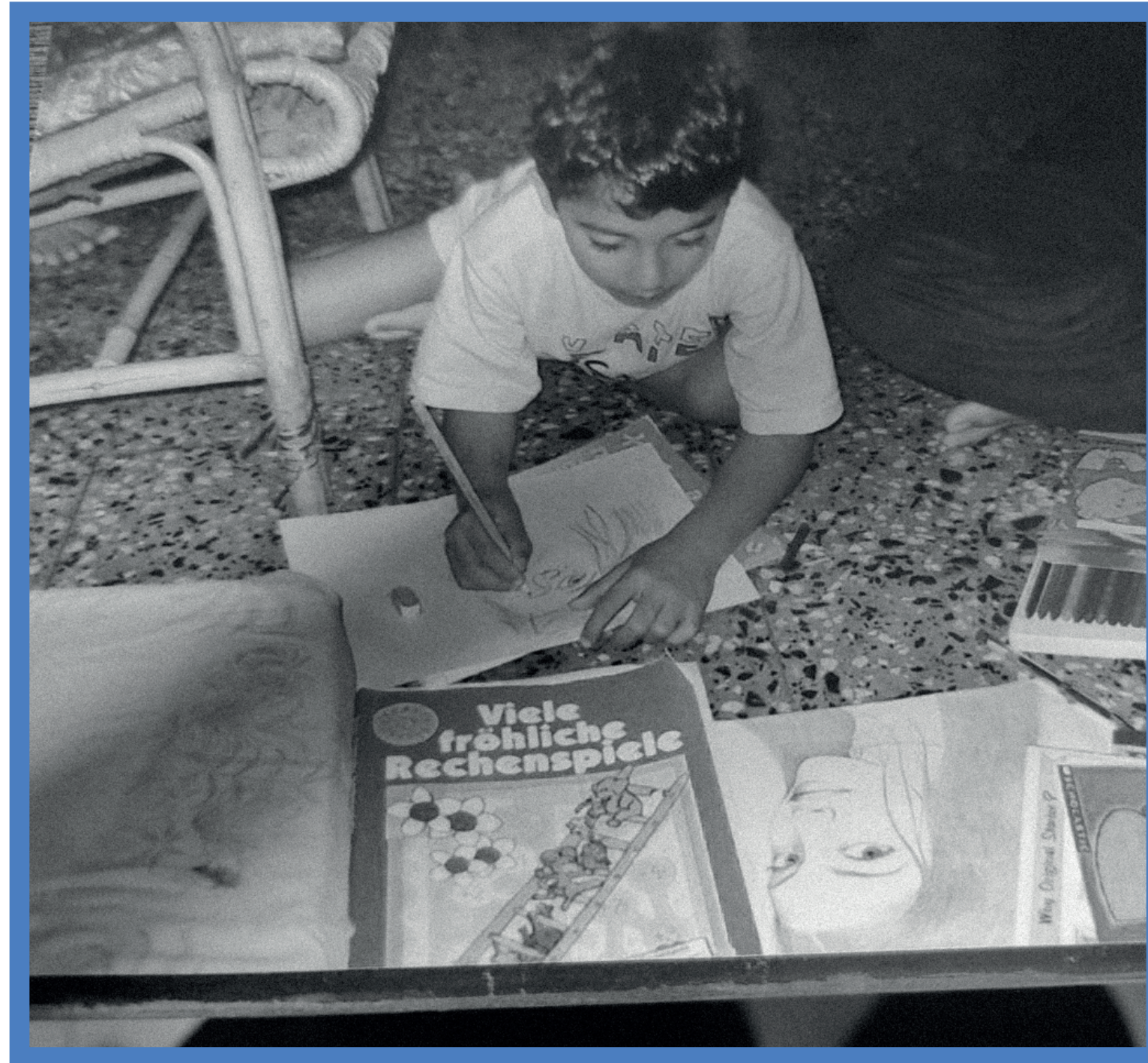

Drawing as a way to express myself

Origins of Fascination

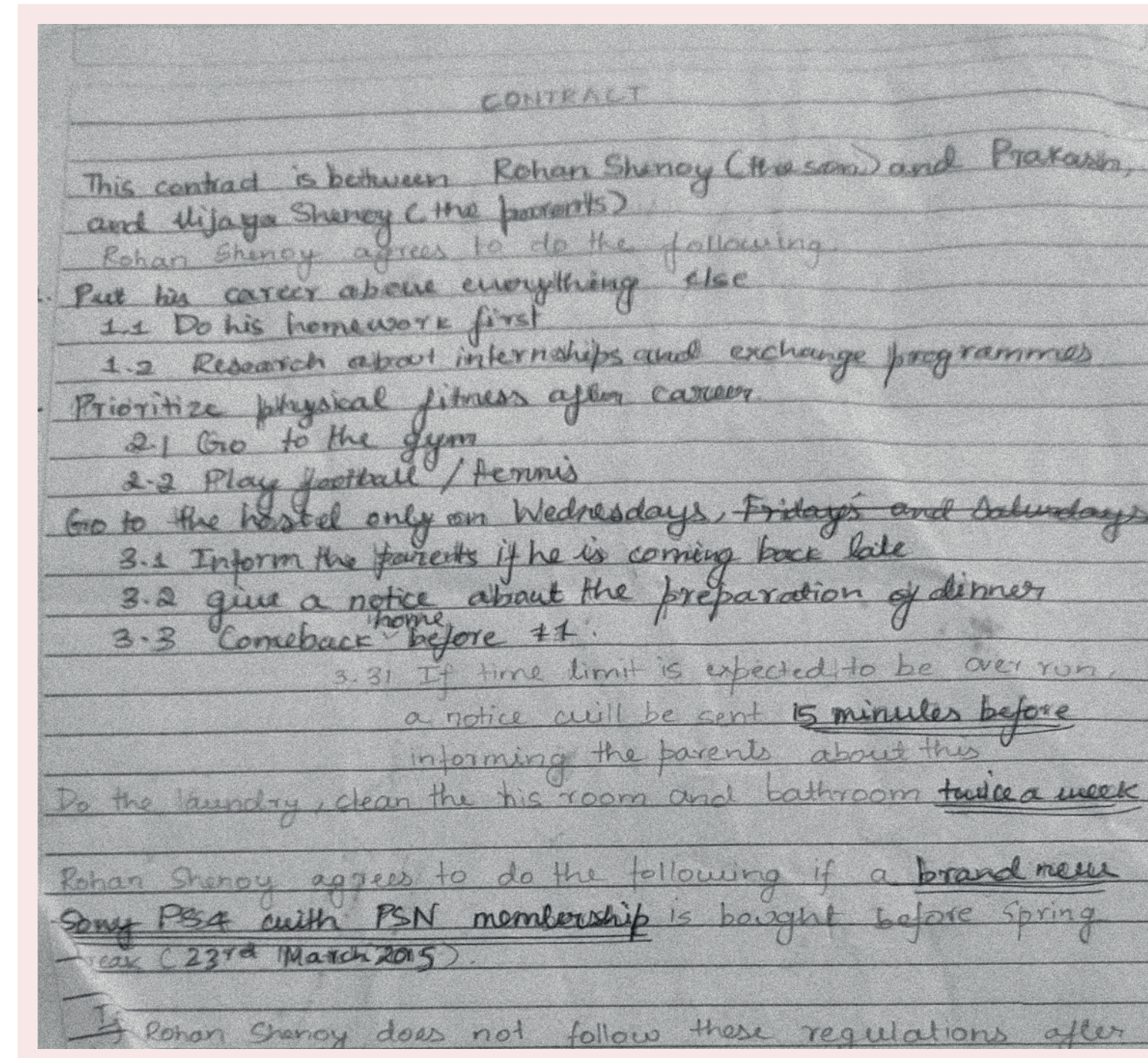

Guadalajara, México, 2015

Origins of Fascination

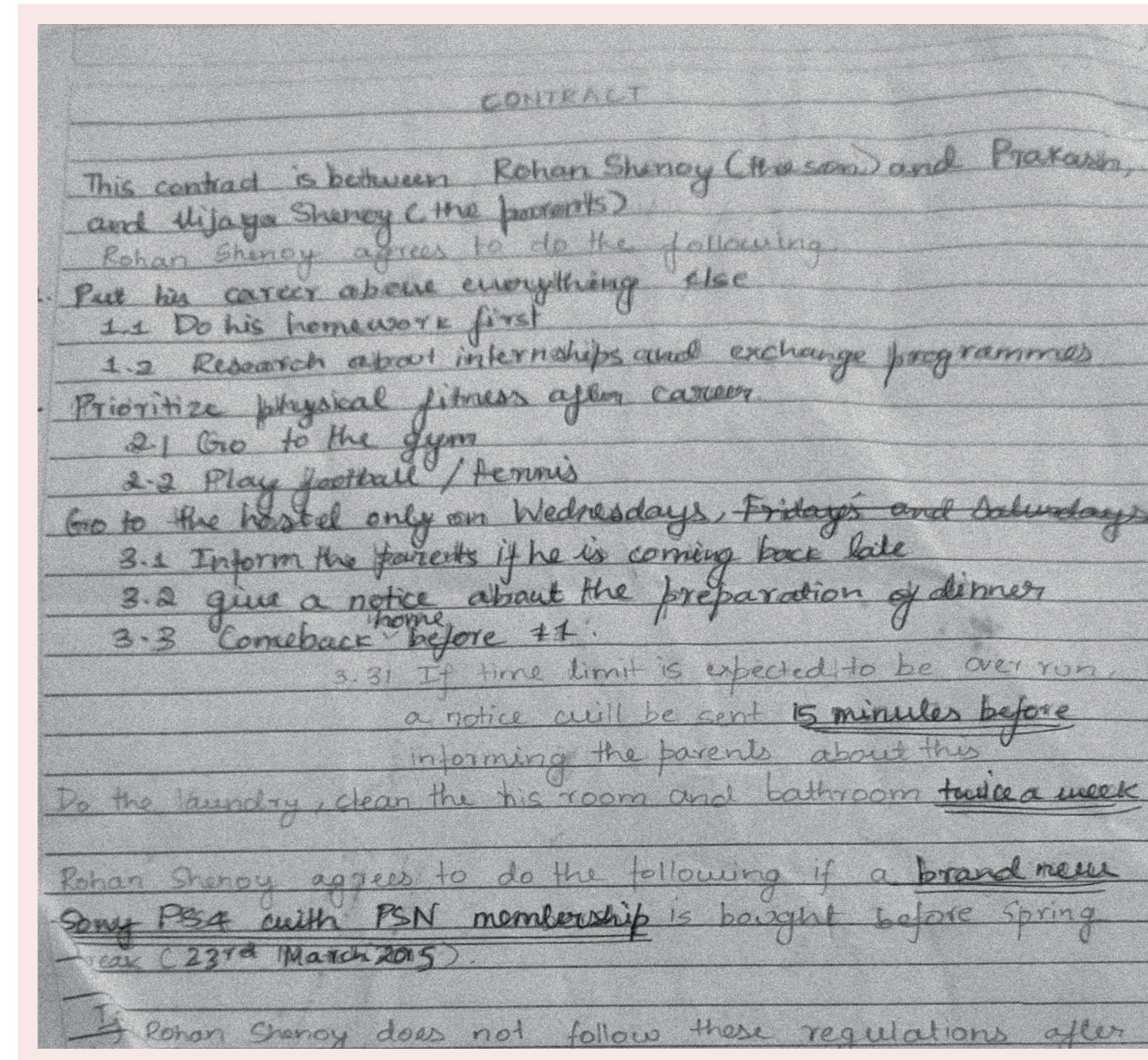

Guadalajara, México, 2015

The contract is between Rohan Shenoy (the son) and Prakash and Vijaya Shenoy (the parents)
Rohan Shenoy agrees to do the following

Put his career above everything else.



<<A state in which people are so involved in an activity that nothing else seems to matter; the experience is so enjoyable that people will continue to do it even at great cost, for the sheer sake of doing it.>>

Mihaly Csikszentmihalyi
(pronounced Me-High Chick-Sent-Me-High)
Flow: the Psychology of Optimal Experience, 2009, p. 15

Flow



Lionel Messi
Copa del Rey final vs Athletic Bilbao, Barcelona, 2015

Flow



Anne Louise Fanger
Fish Scale Coffee Mug, Copenhagen, 2018





1.

The Art of Acquiring Flow

**Part 1 recapitulates the aims, the results,
and the limitations of the research project**

The Croquis

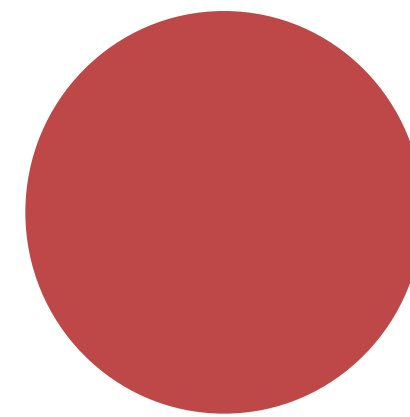
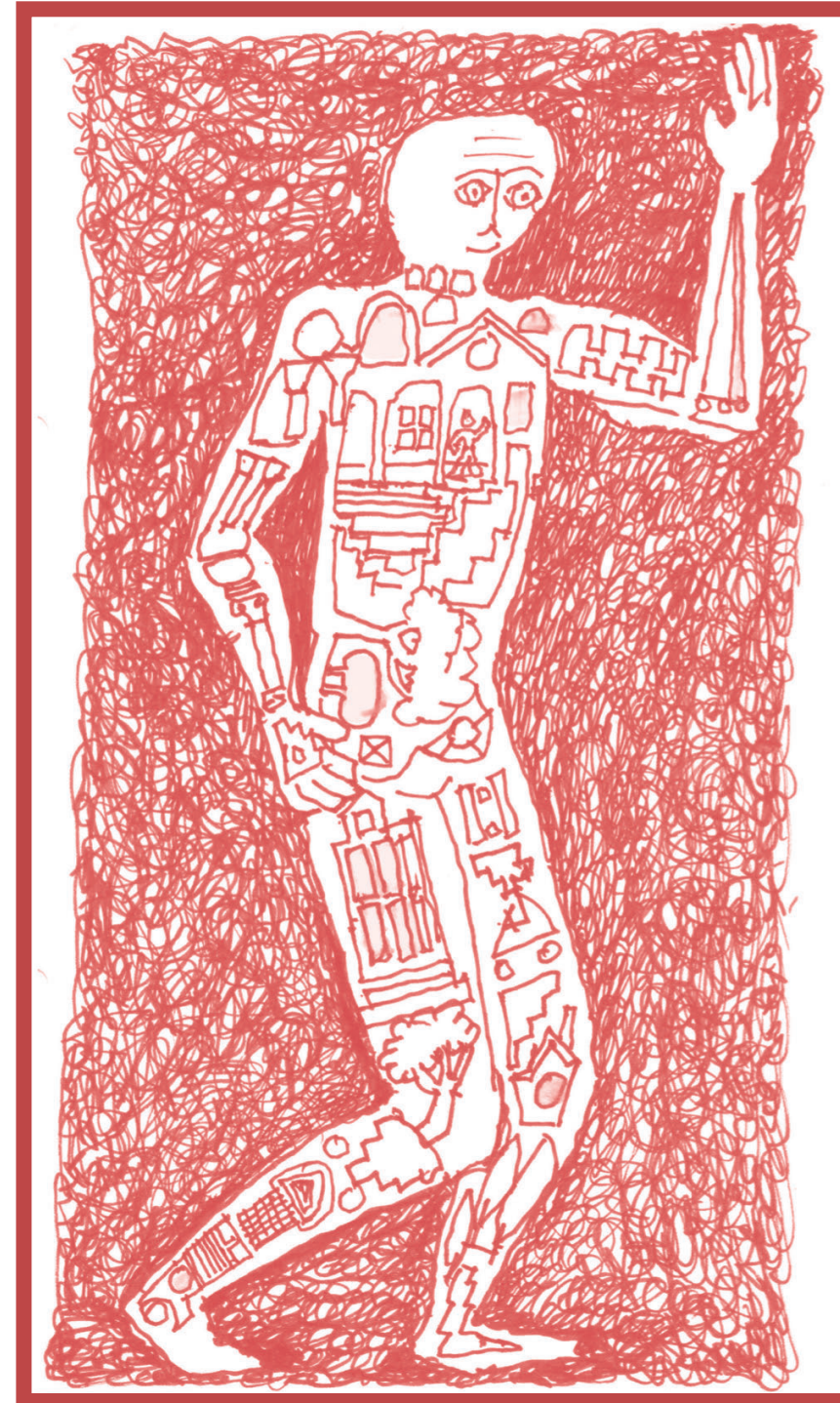

Marco Frascari
Architectural Embodiment, 2016

The Research Question

«How does the use of croquis, as an architectural design tool, aid the process of creating <design *flow*> during conceptual ideation?»»

Digital

Analogue

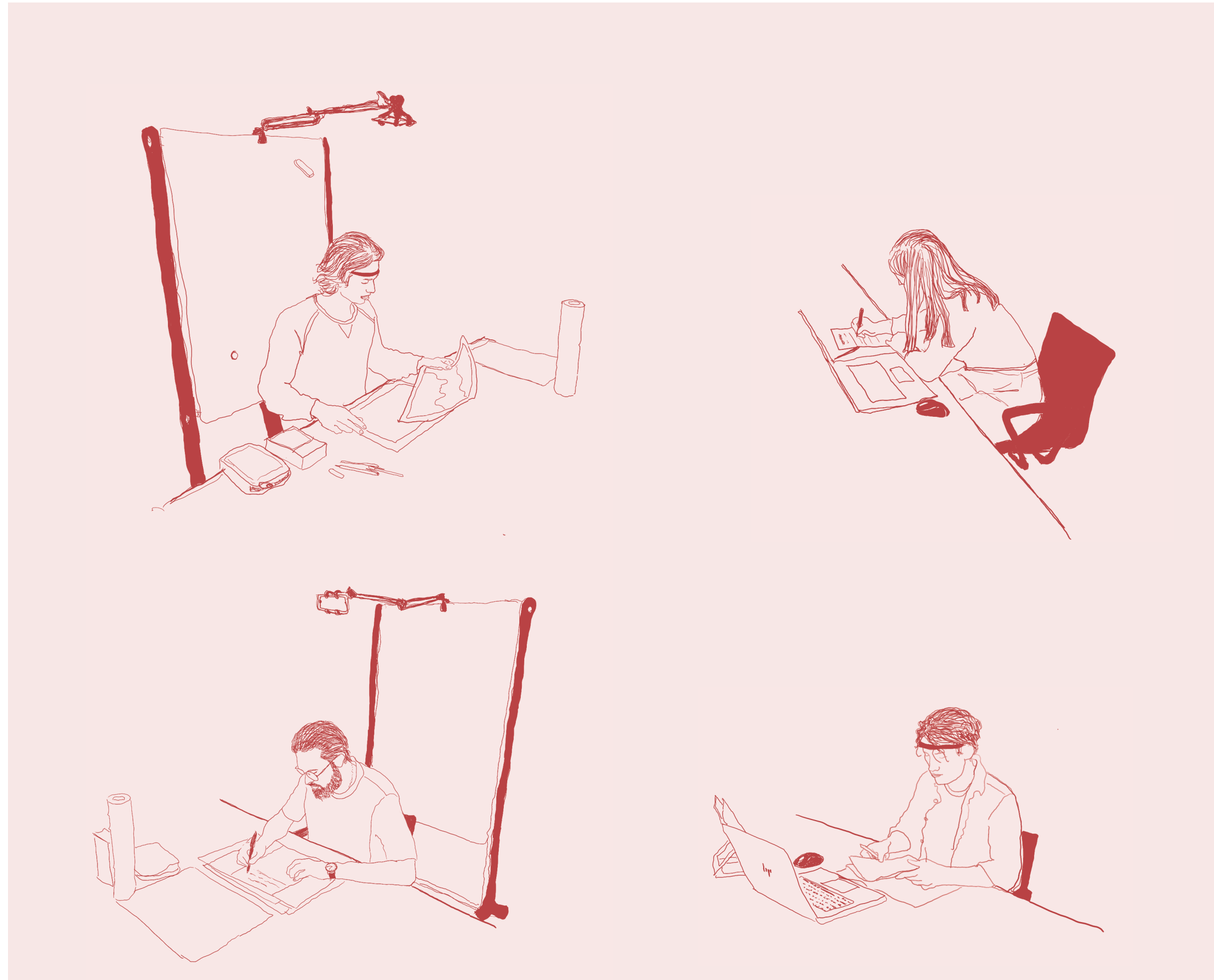

Digital

Analogue

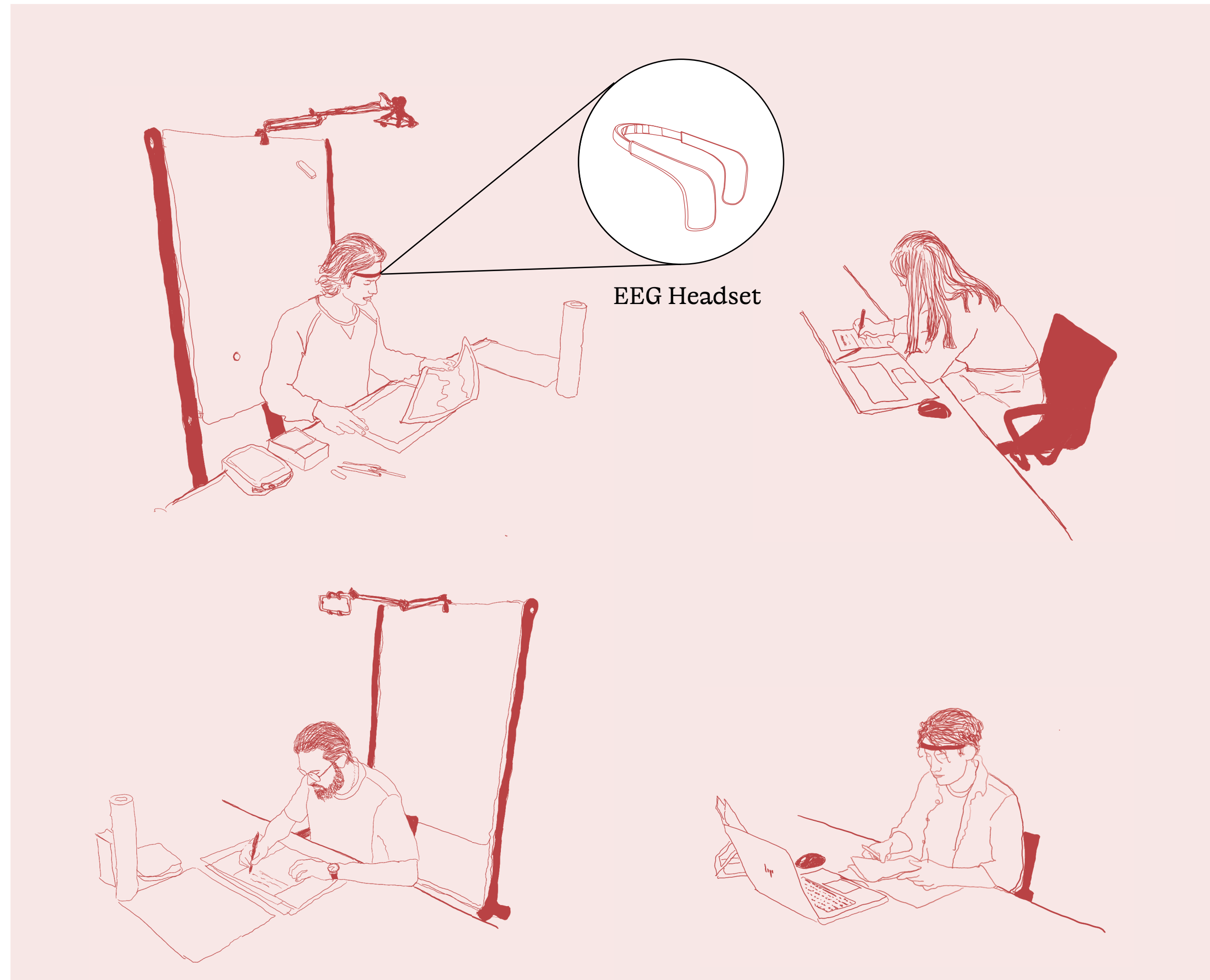

Digital

Analogue

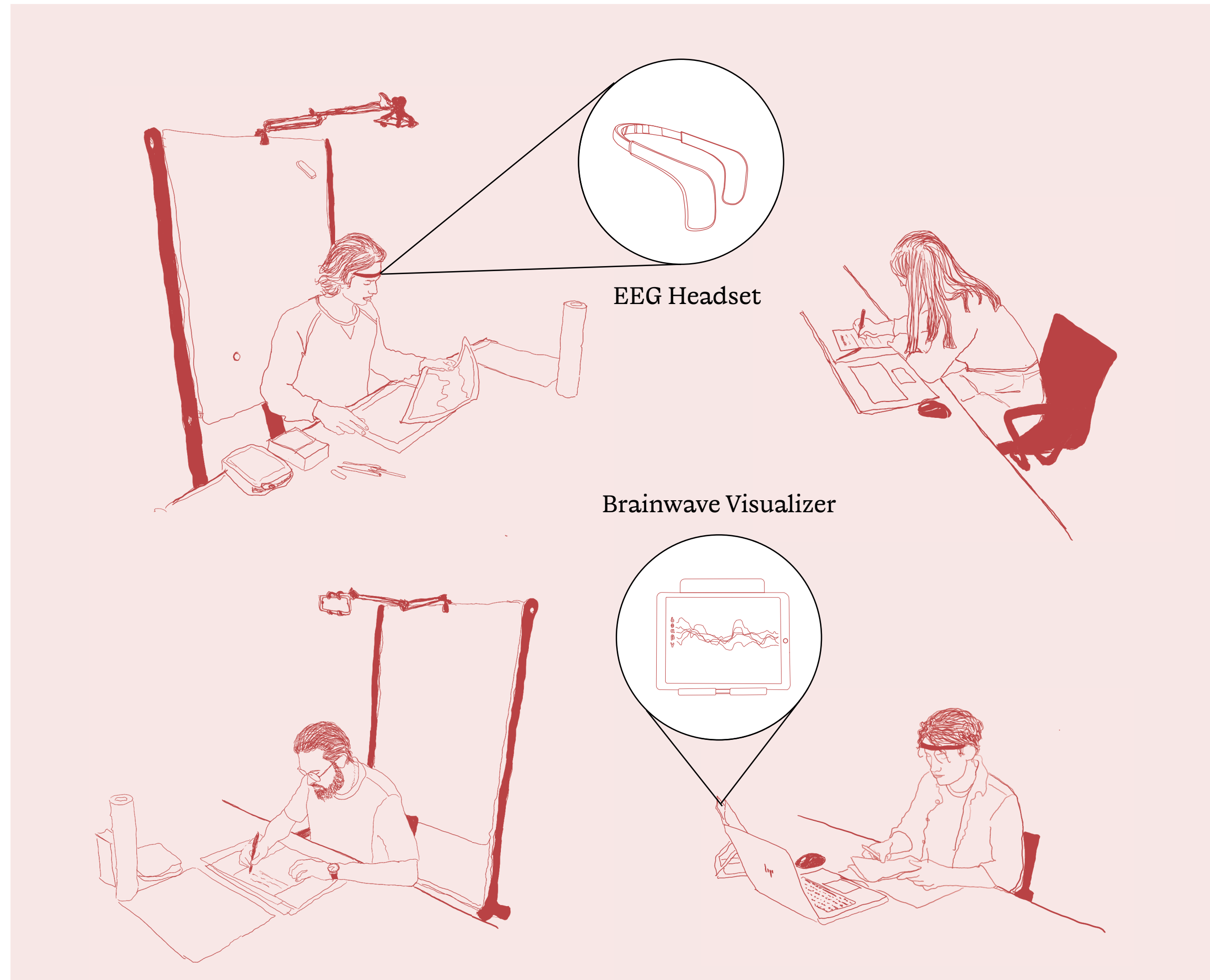

Digital

Analogue

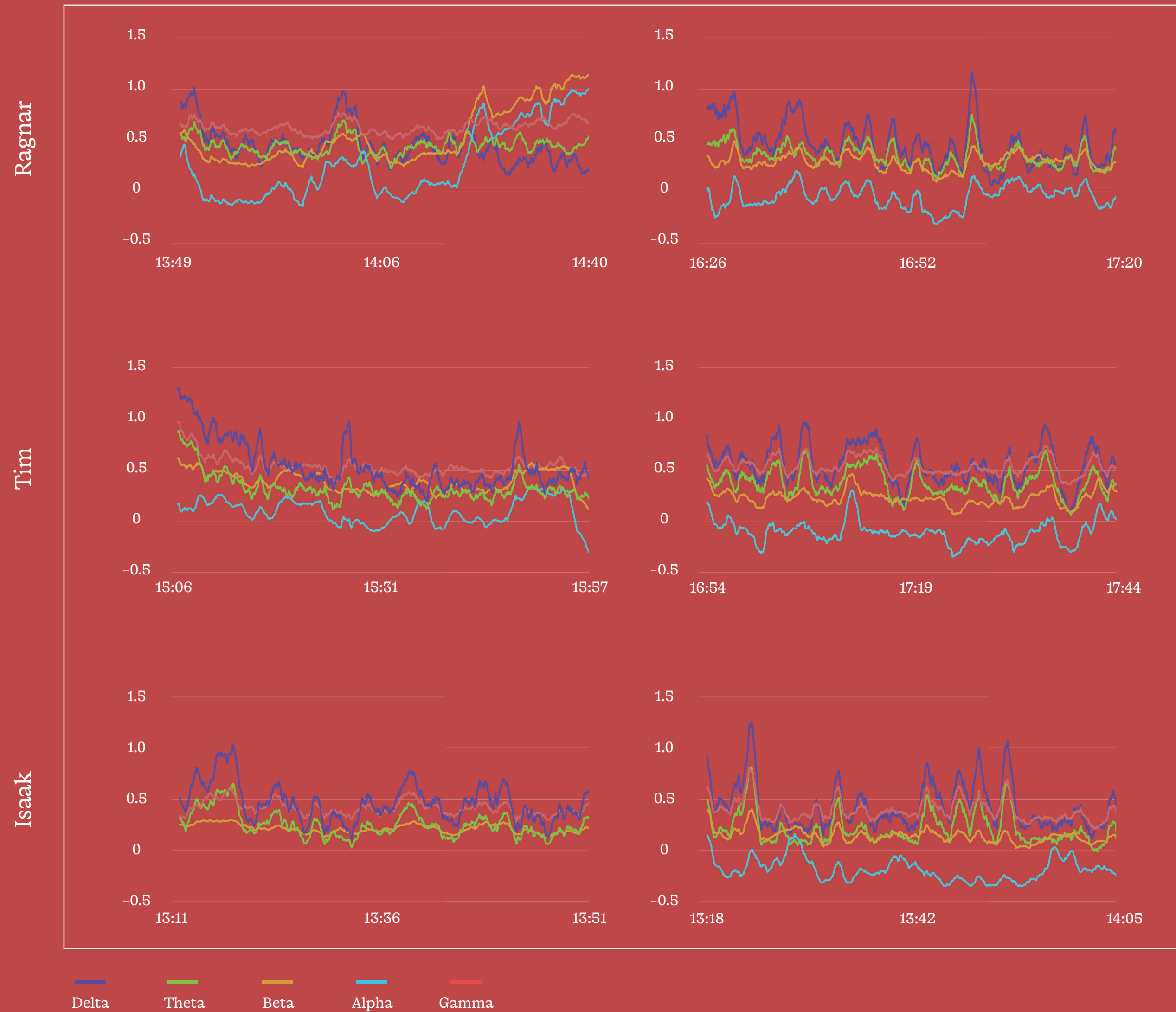

Digital

Analogue



Delta
Deep sleep

Ragnar

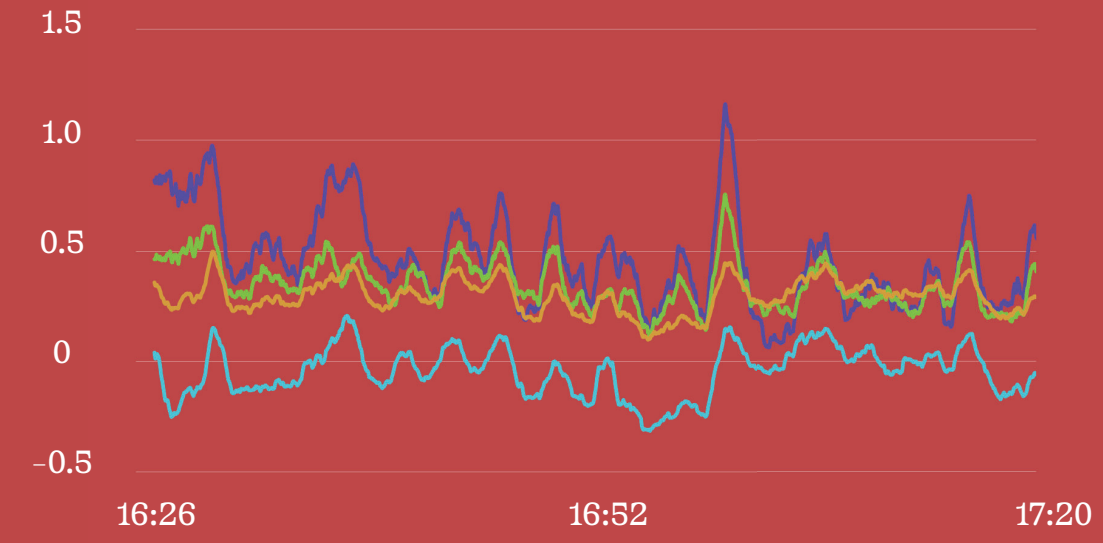
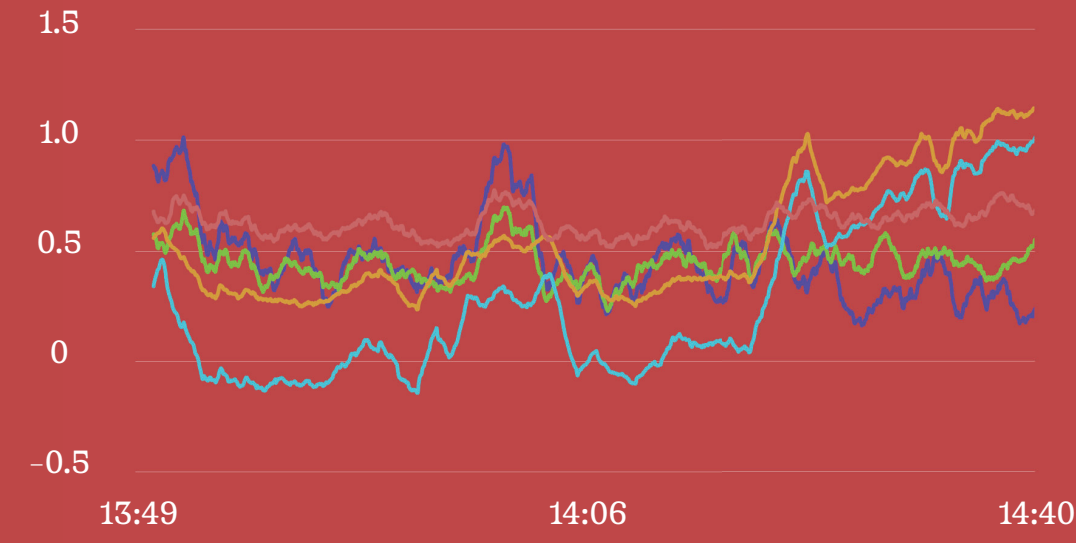

Tim

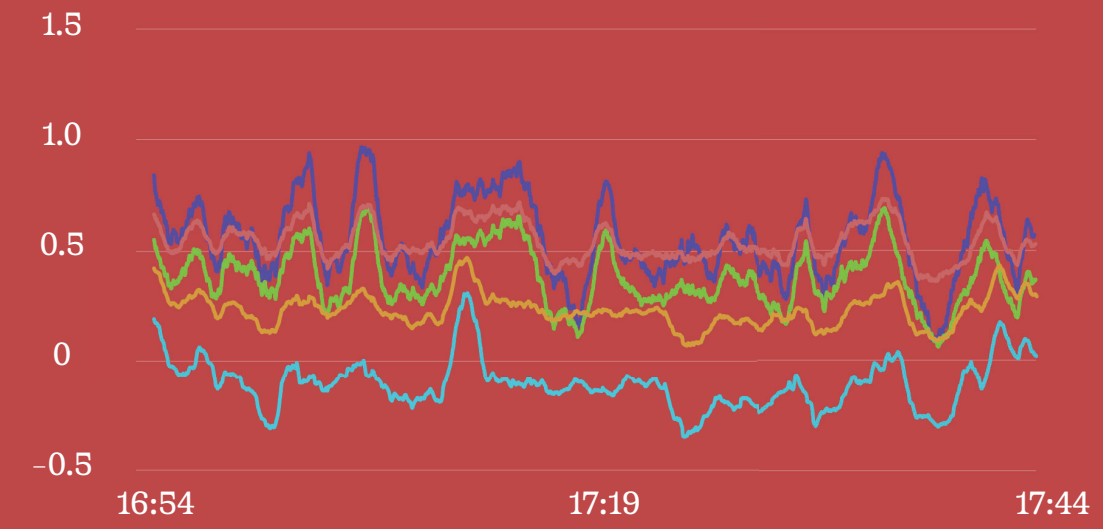
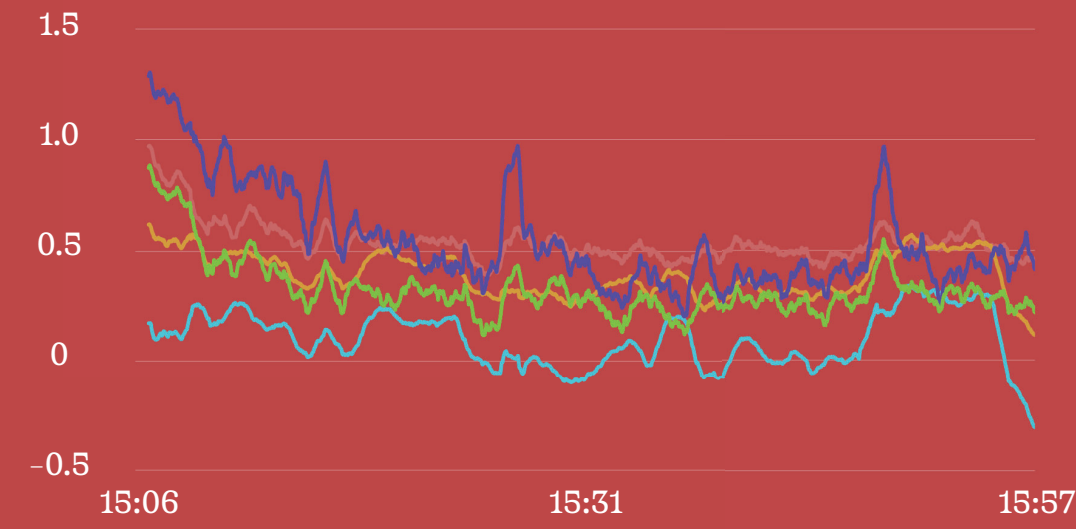

Isaak

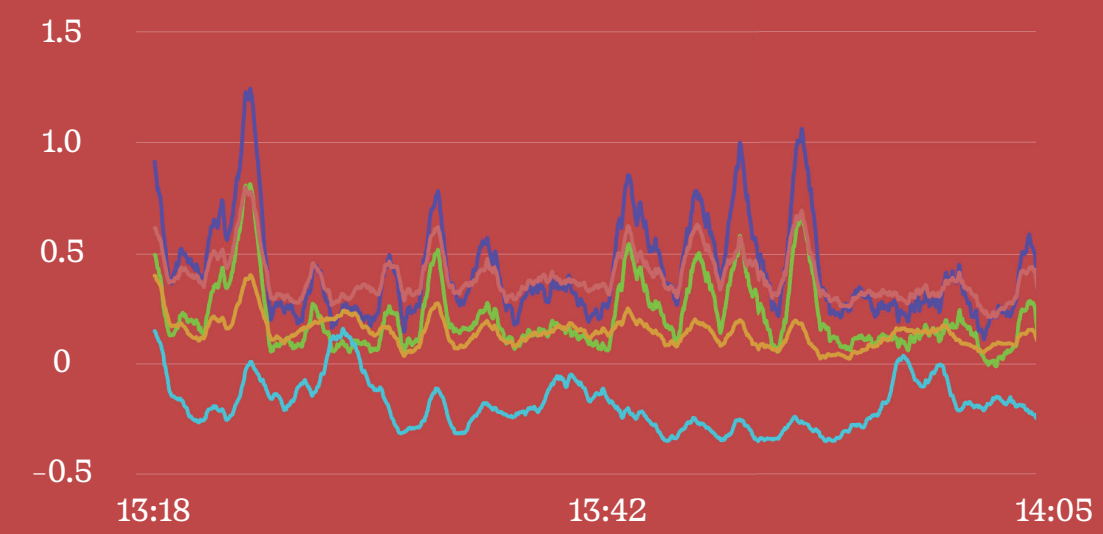
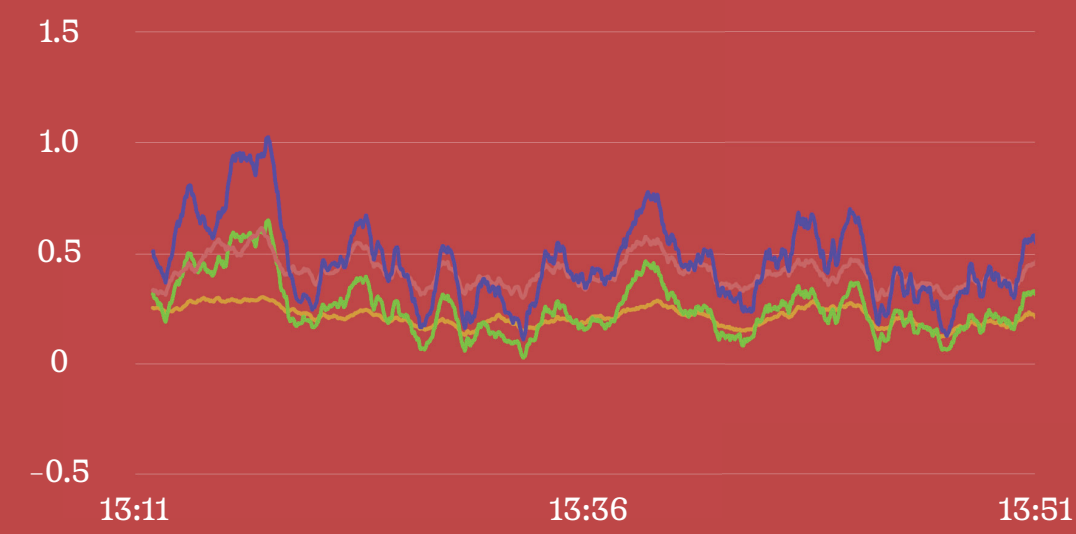

Delta Theta Beta Alpha Gamma

Digital

Analogue



Delta Theta Beta Alpha Gamma



Delta
Deep sleep



Theta
Light sleep

Digital

Analogue

Ragnar

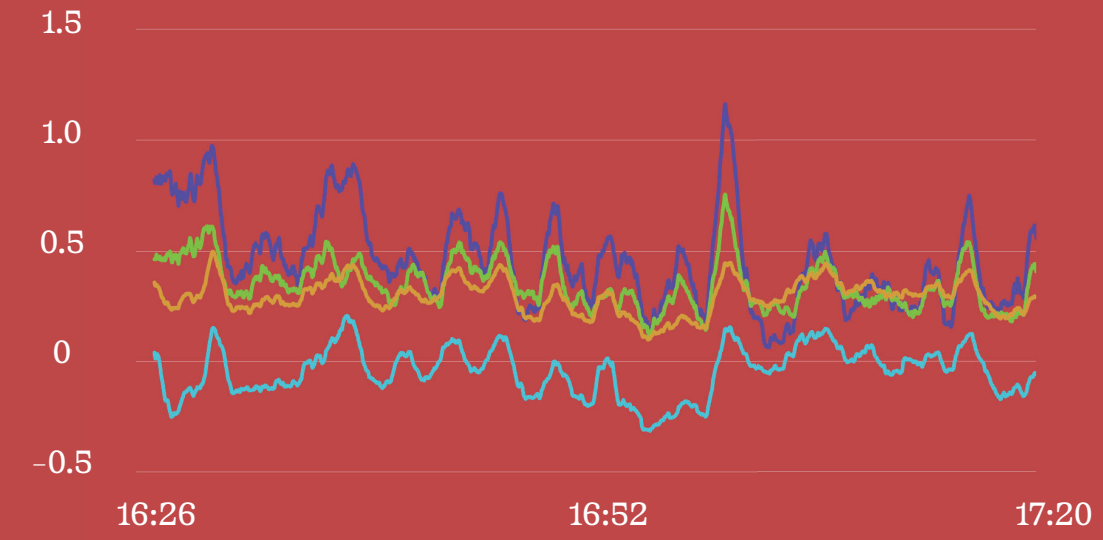
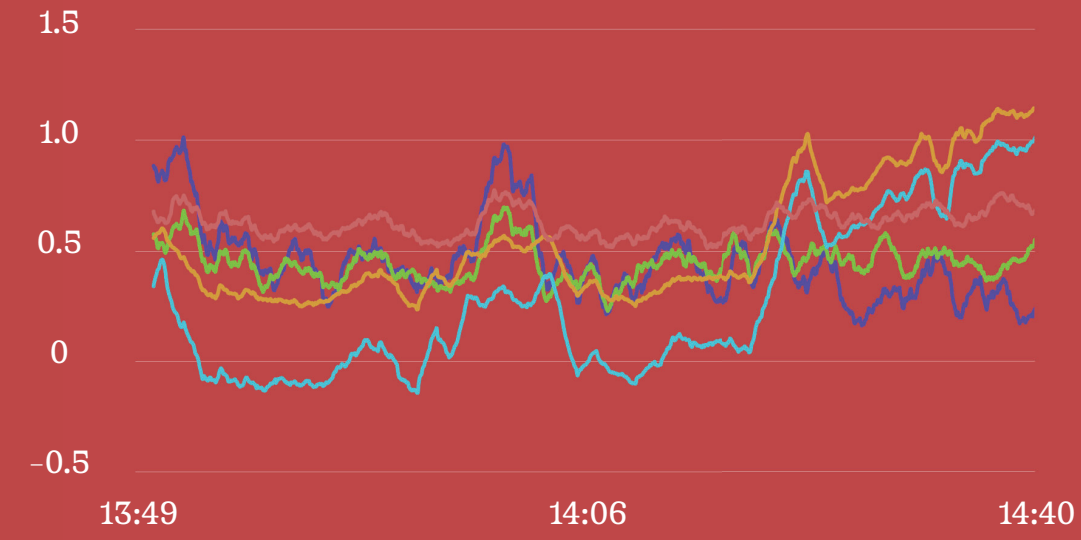

Tim

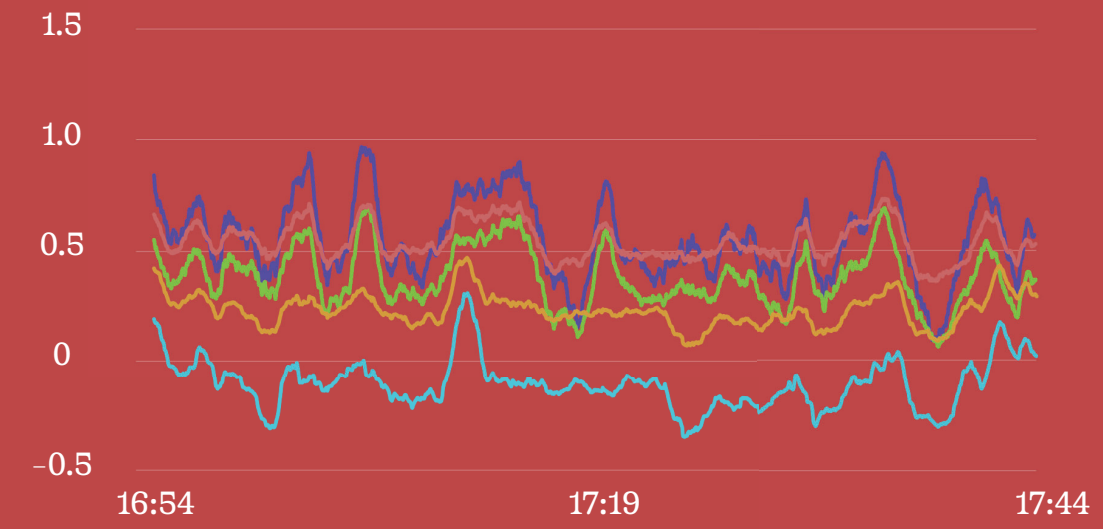
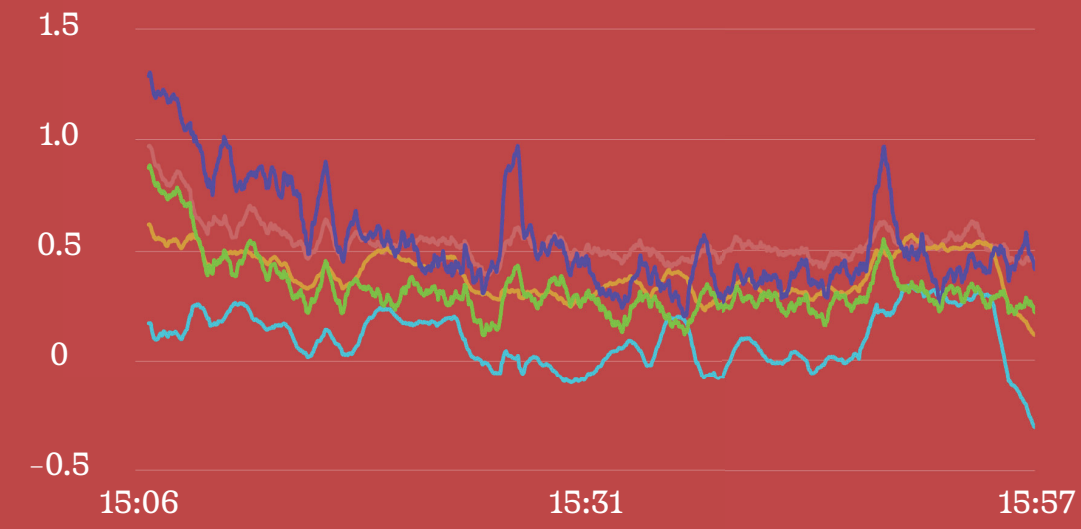

Isaak

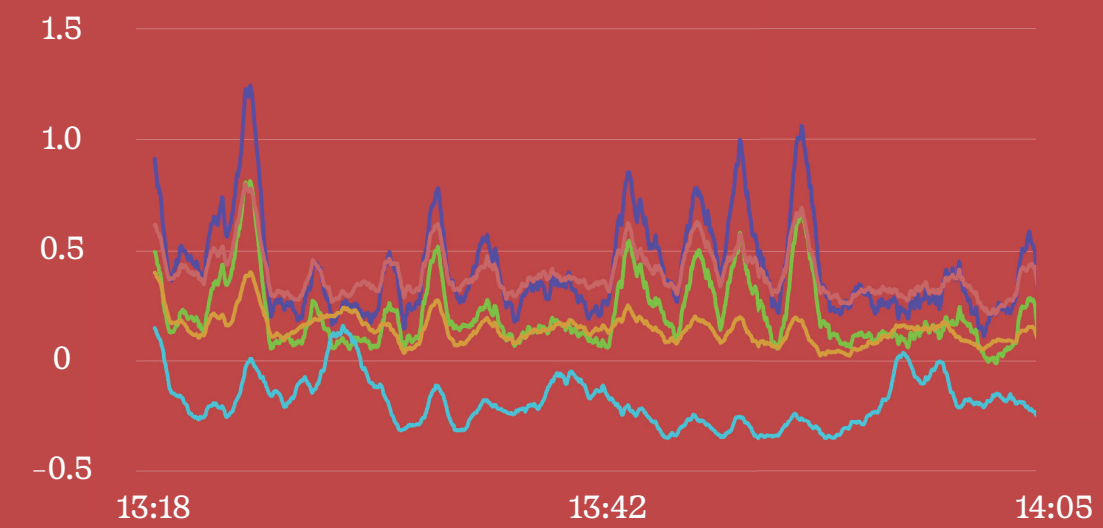
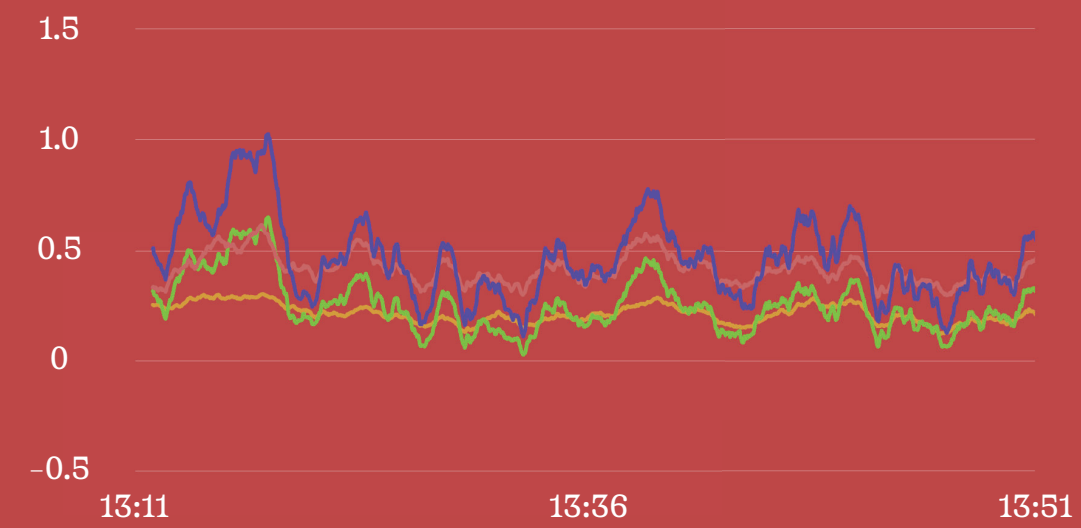

Delta Theta Beta Alpha Gamma



Delta
Deep sleep



Theta
Light sleep



Alpha
Calm

Digital

Analogue

Ragnar

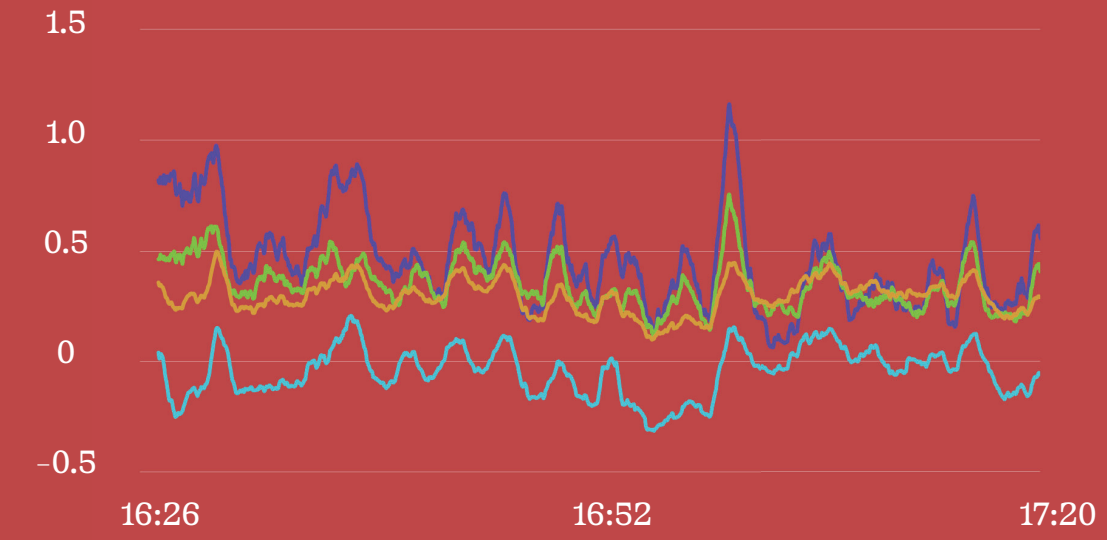
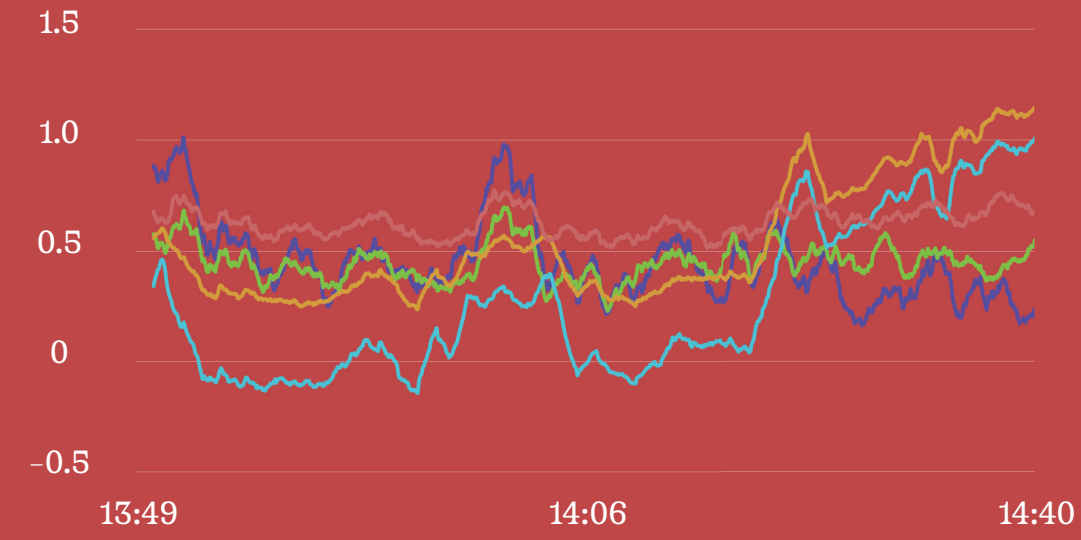

Tim

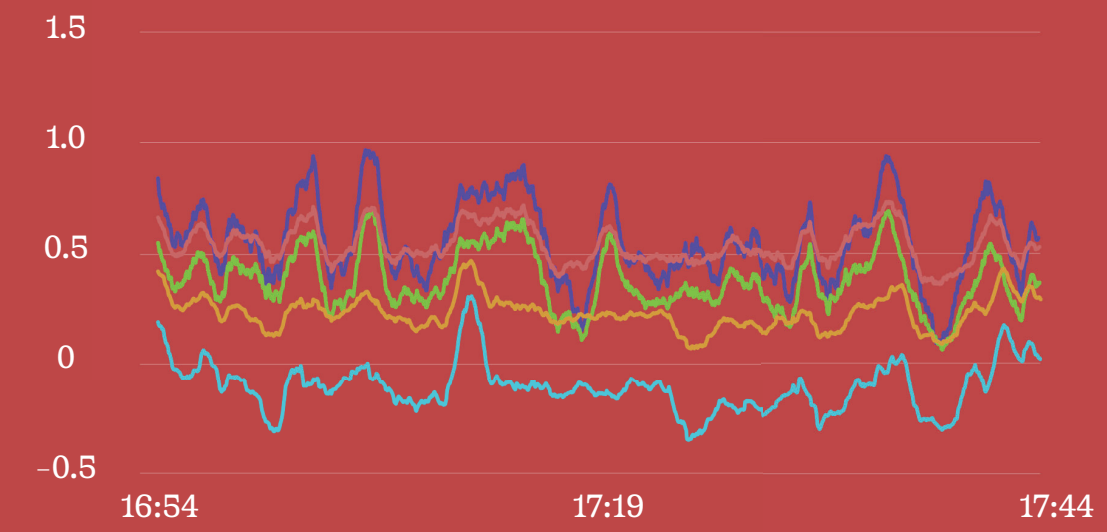
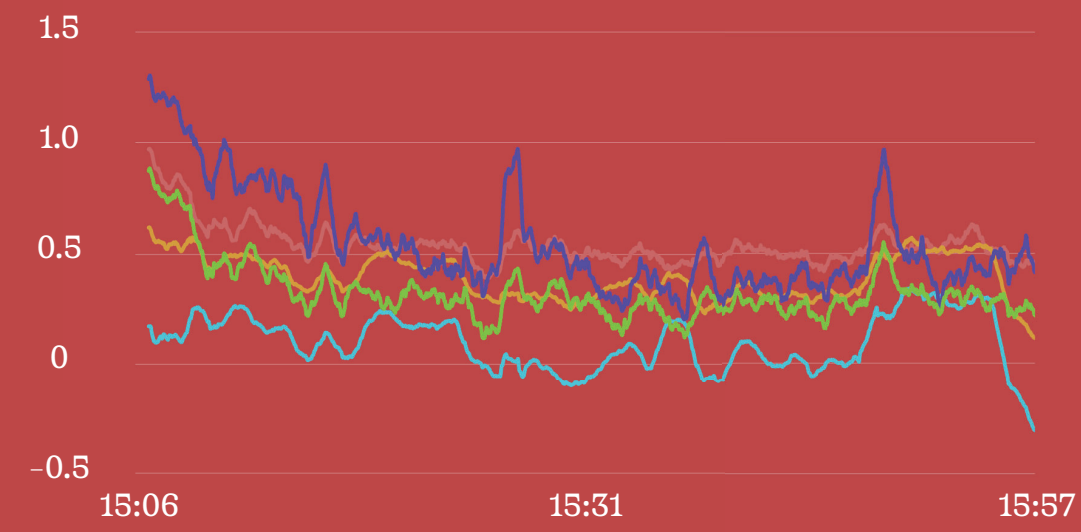

Isaak

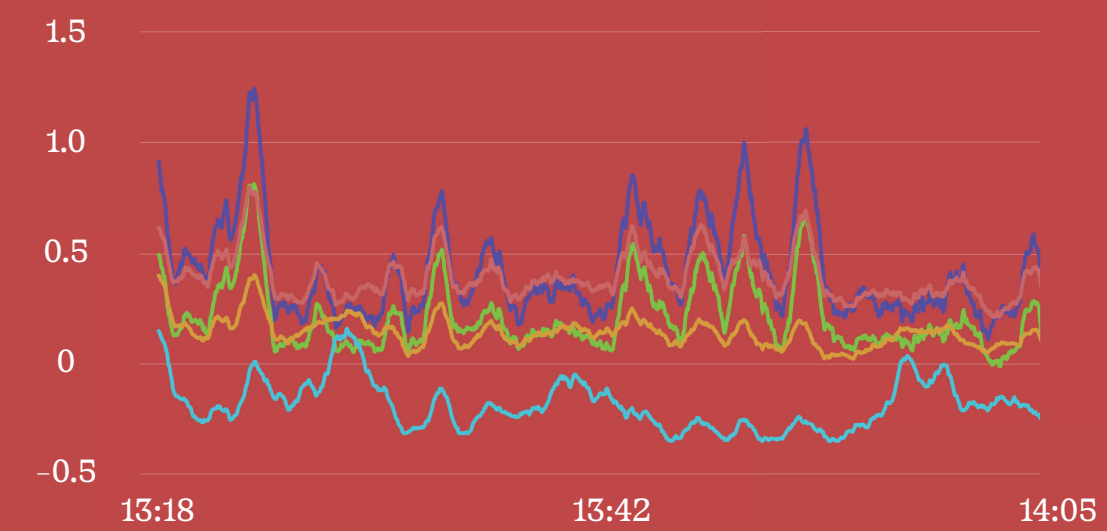
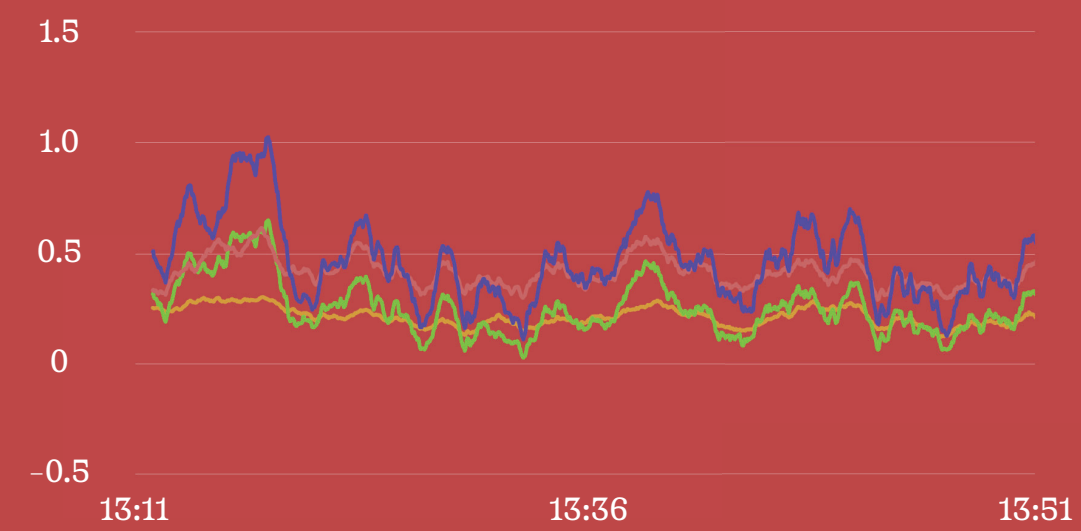

Delta Theta Beta Alpha Gamma



Delta
Deep sleep



Theta
Light sleep



Alpha
Calm



Beta
Alert

Digital

Analogue



Delta Theta Beta Alpha Gamma



Delta
Deep sleep



Theta
Light sleep



Alpha
Calm



Beta
Alert

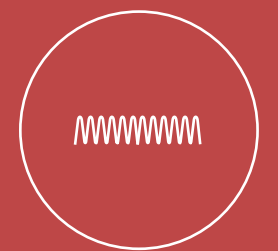

Gamma
Deep thinking

Digital

Analogue



Delta
Deep sleep

Ragnar

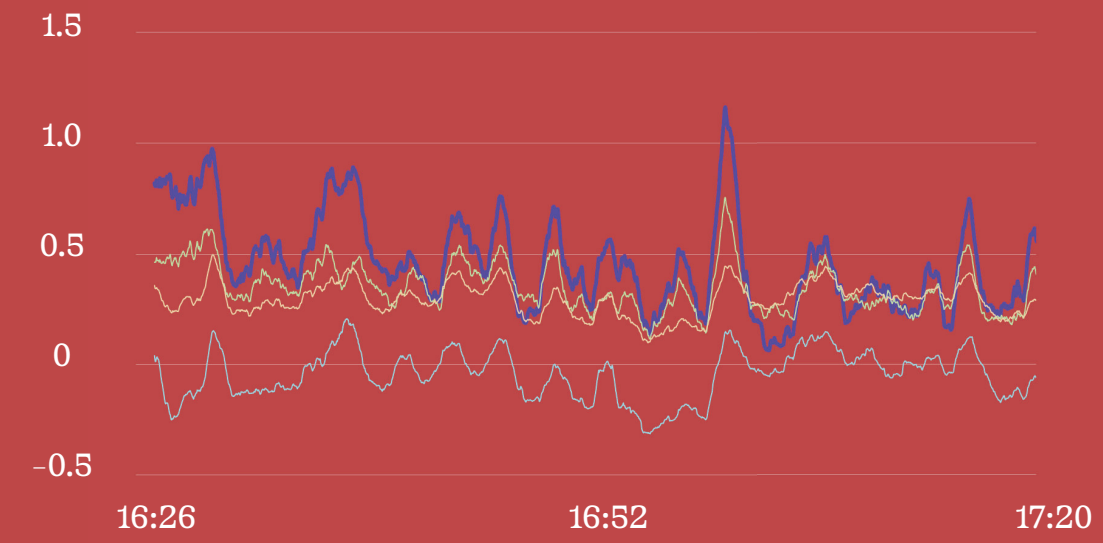
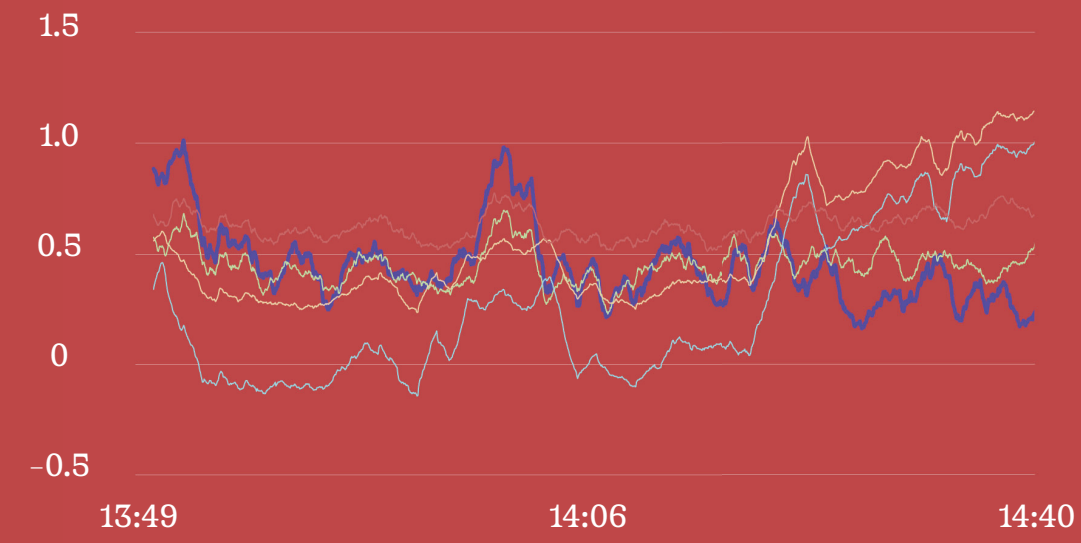

Tim

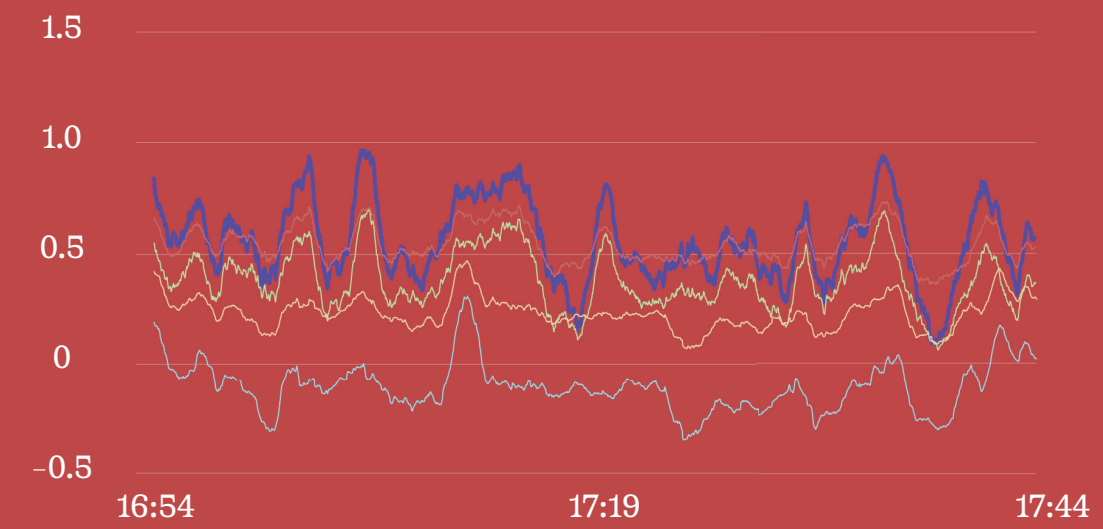
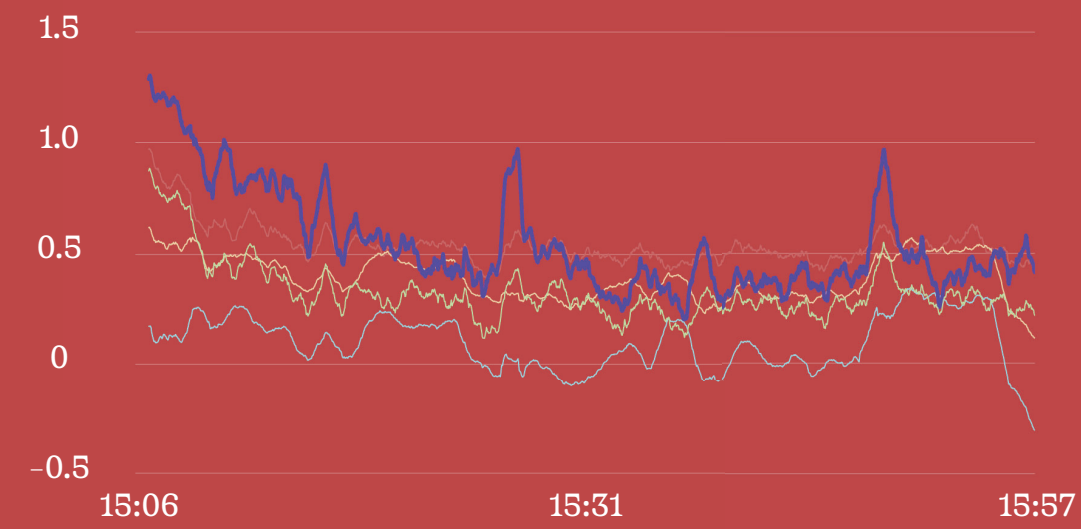

Isaak

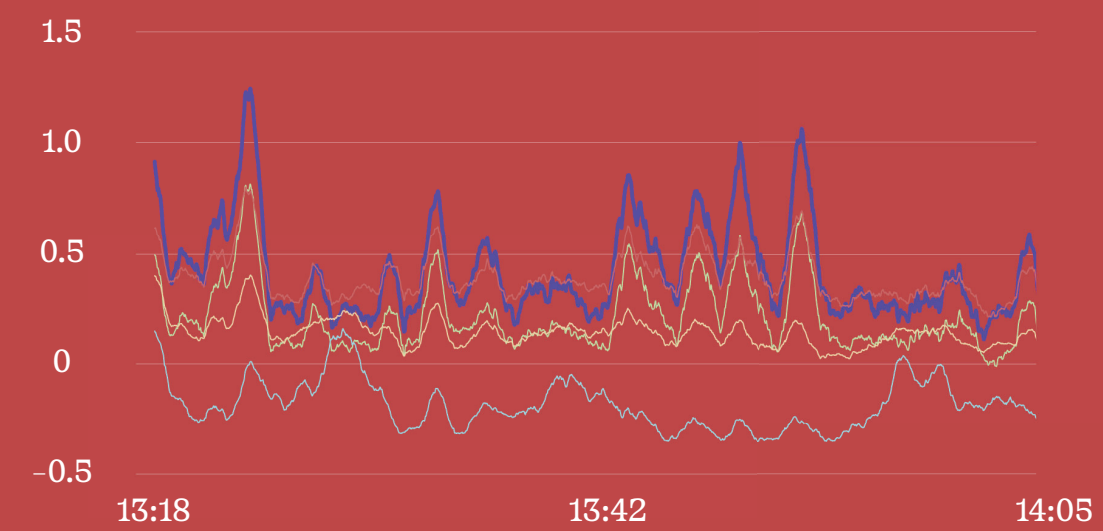
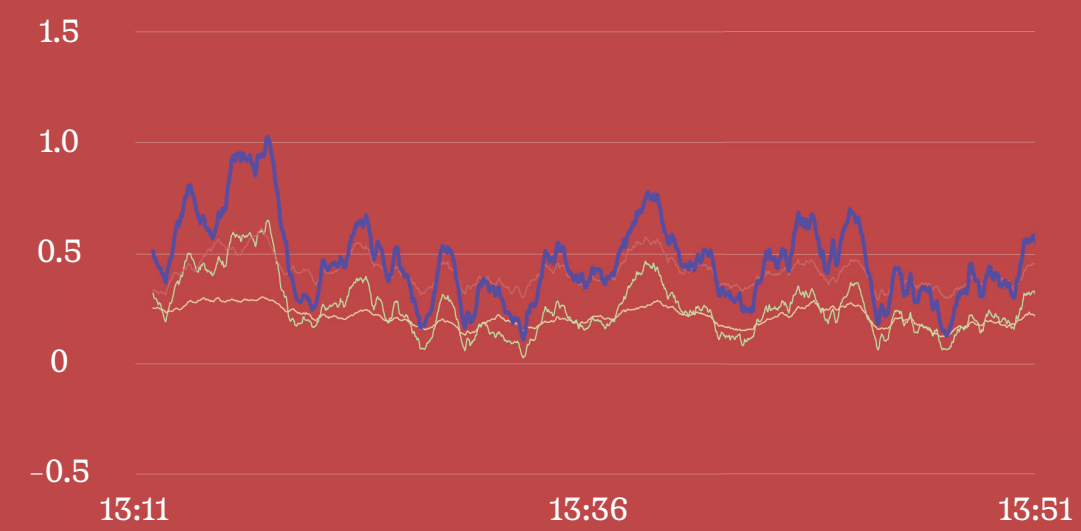

Delta Theta Beta Alpha Gamma

Digital

Analogue

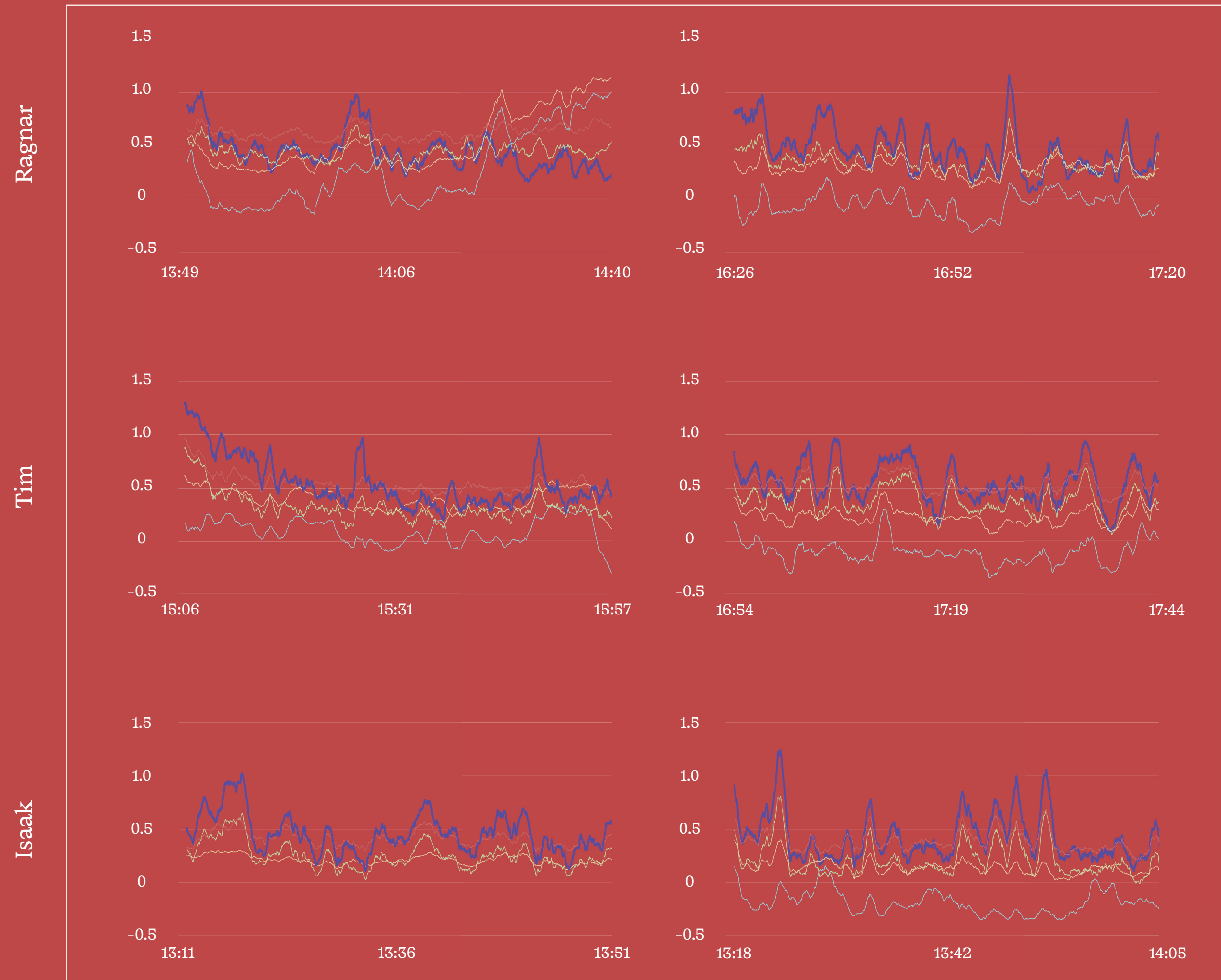

Delta
Deep sleep



Loss of bodily awareness

Delta Theta Beta Alpha Gamma

Loss of Bodily Awareness



Analogue sketching workshop session
The Art of Acquiring Flow, 2022

Digital

Analogue

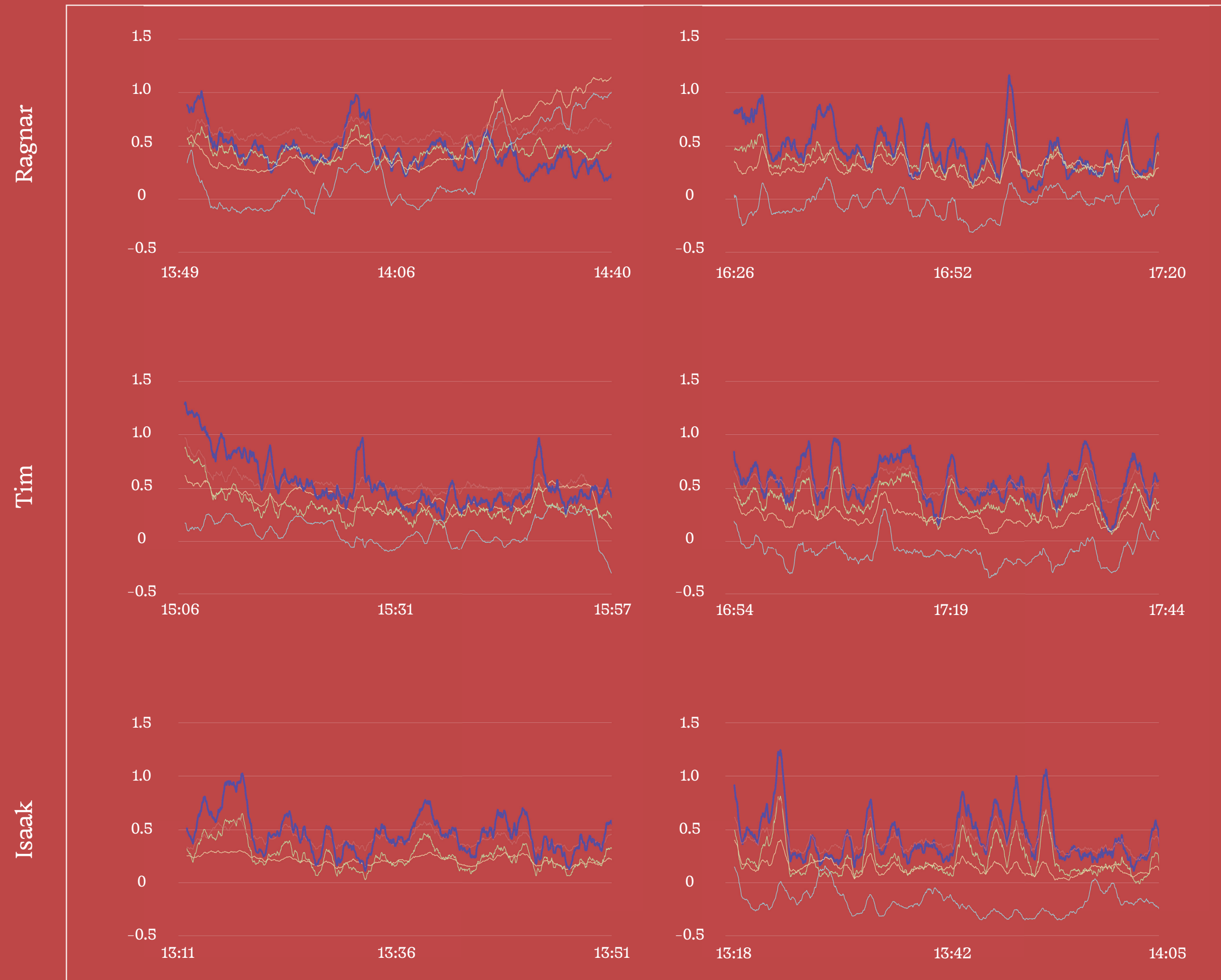

Delta Theta Beta Alpha Gamma



Delta
Deep sleep



Loss of bodily awareness

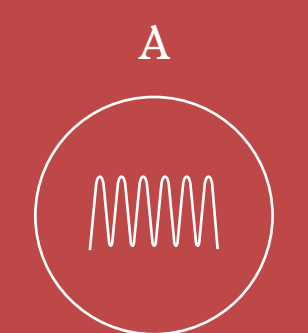
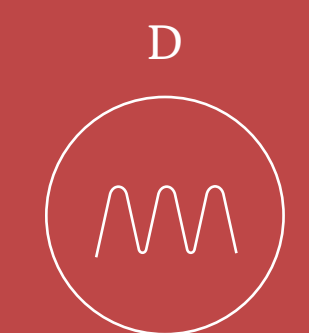

Greater frequency

Digital

Analogue



Theta
Light sleep

Ragnar

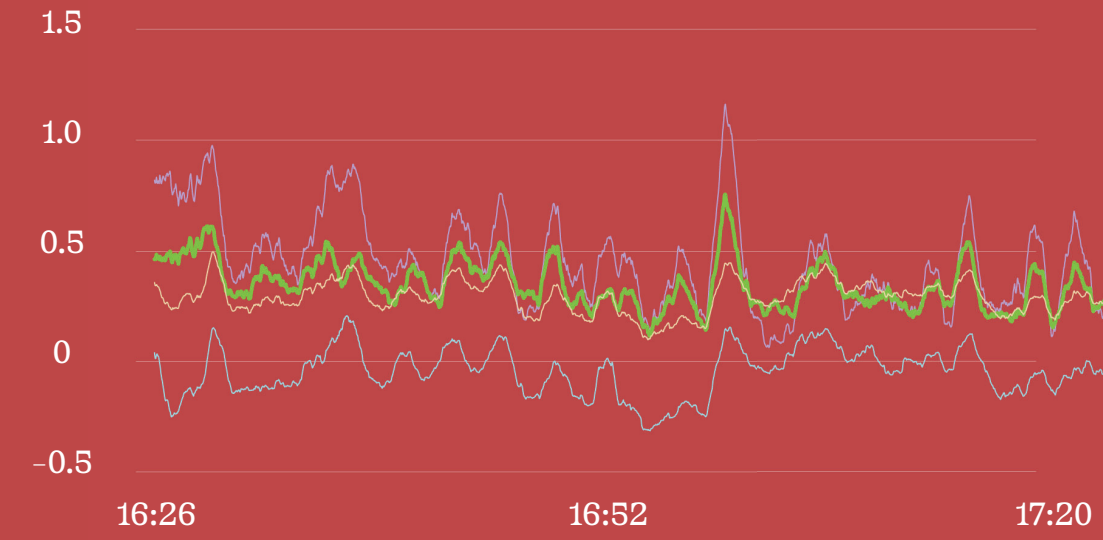
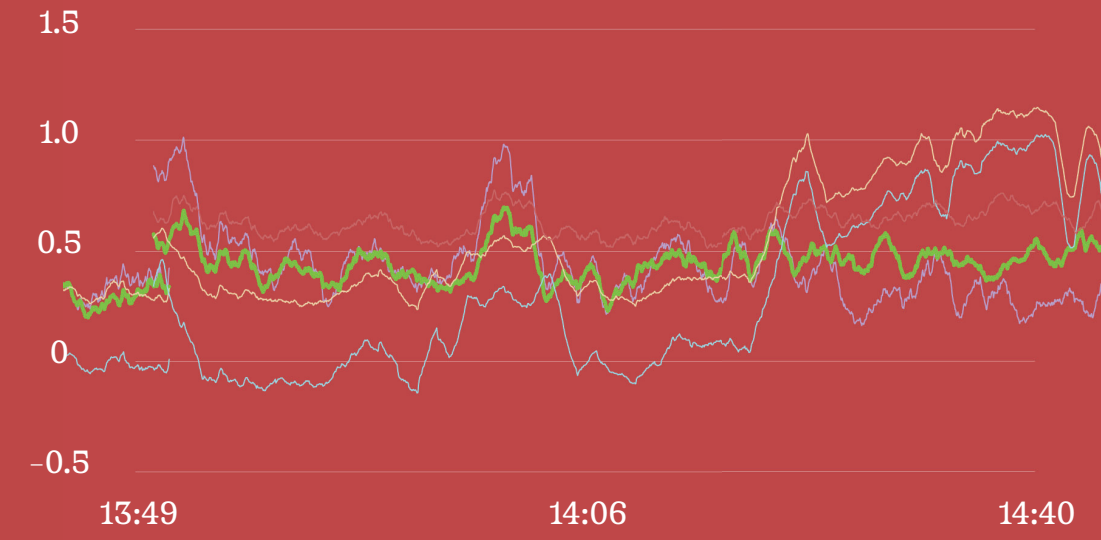

Tim

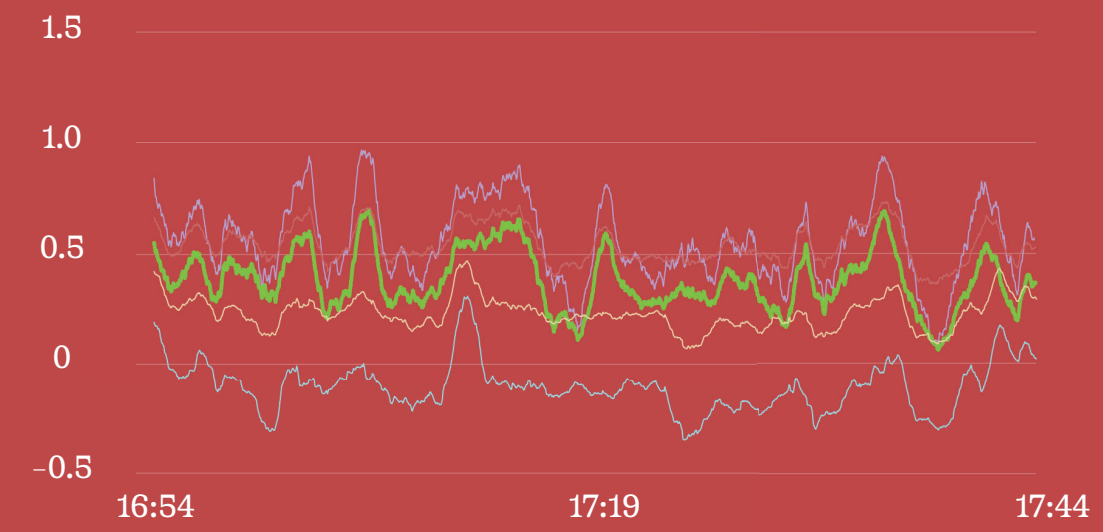
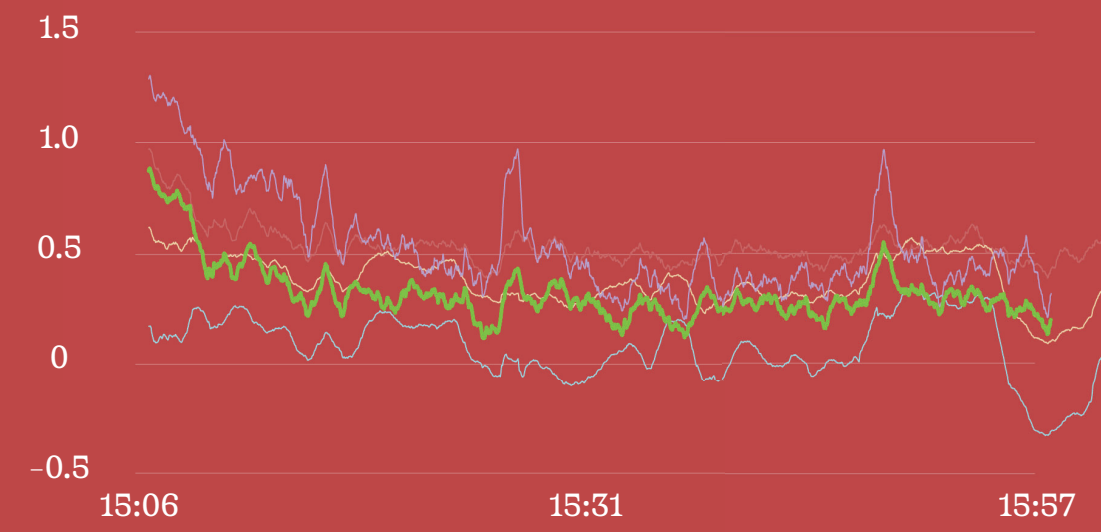

Isaak

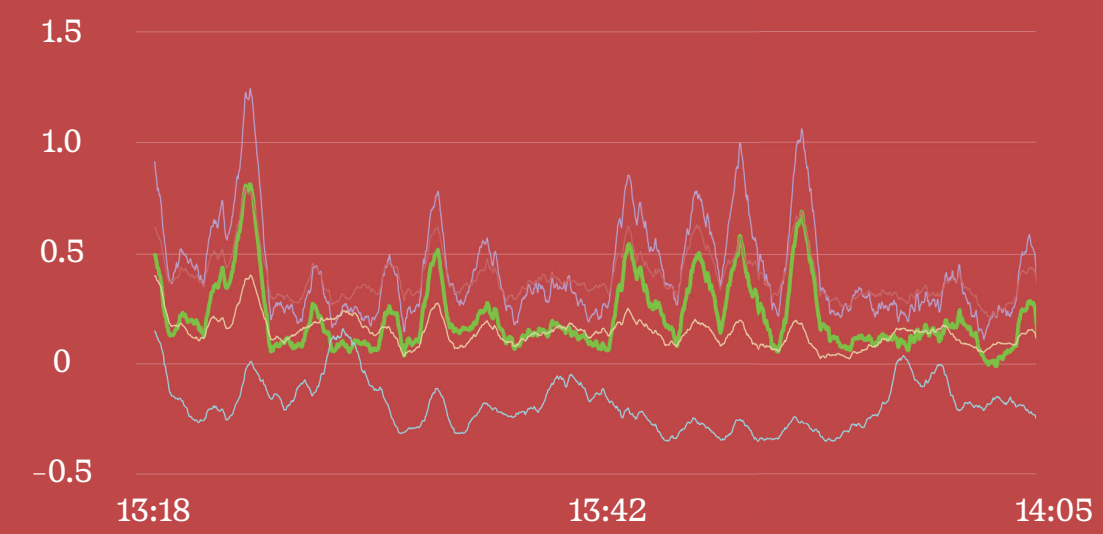
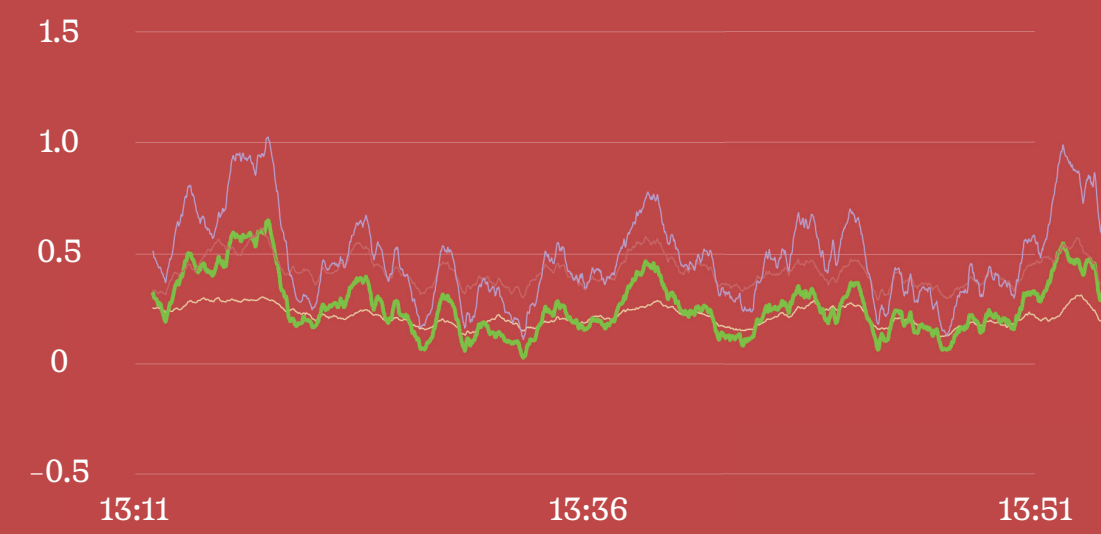

Delta Theta Beta Alpha Gamma

Digital

Analogue



Delta Theta Beta Alpha Gamma



Theta
Light sleep



Creativity

The Shower

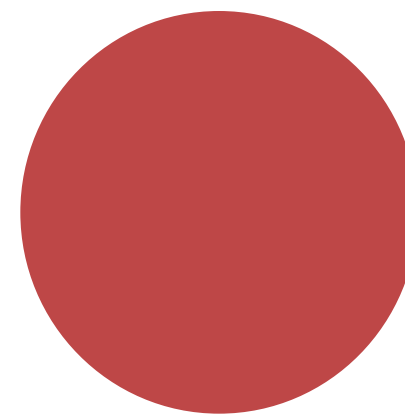
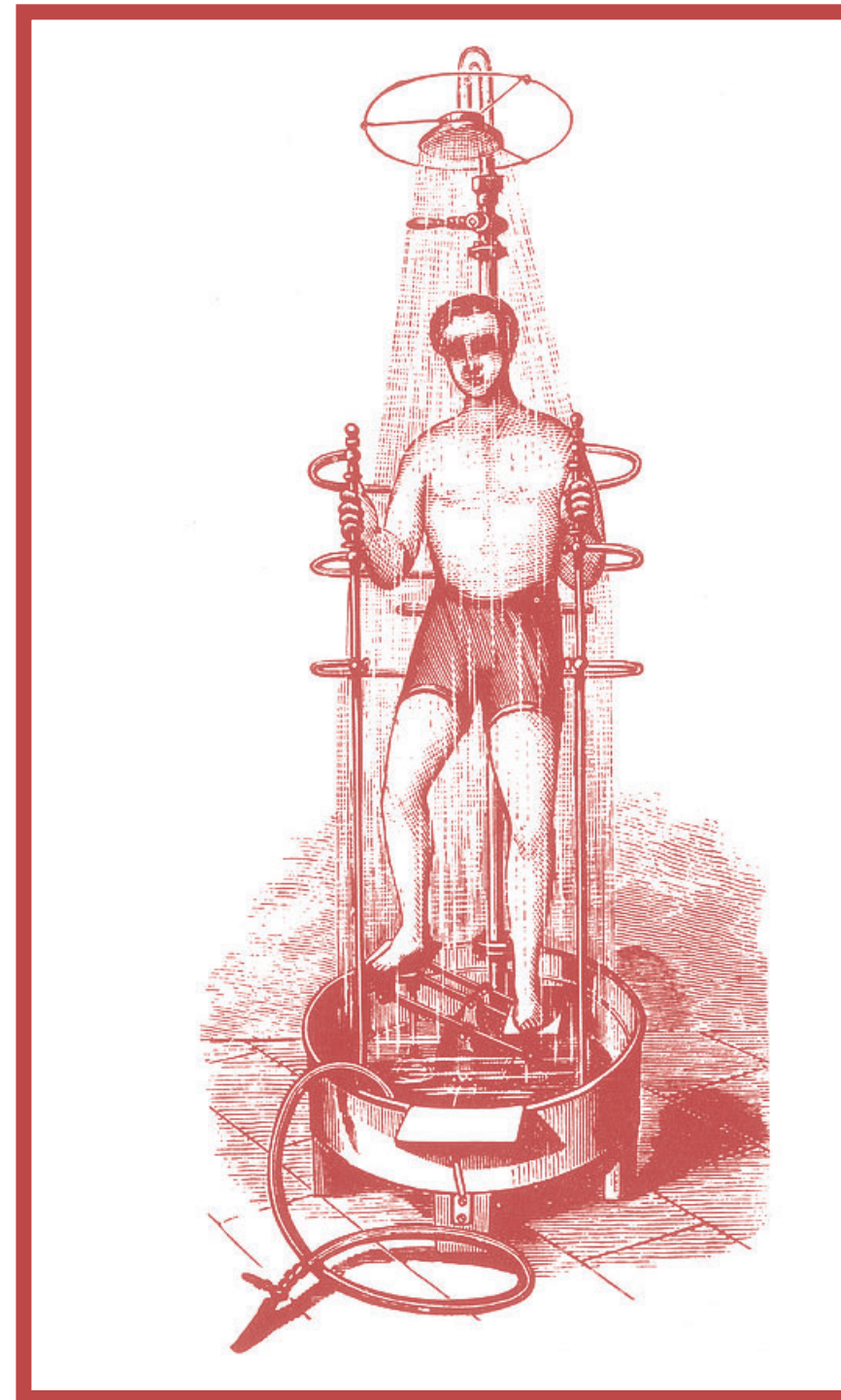

Gaston Bozerian
Bozerian Shower Bath, 1878

Digital

Analogue



Delta Theta Beta Alpha Gamma



Theta
Light sleep



Creativity

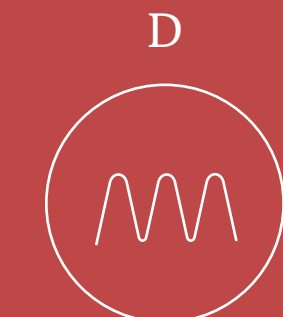

D

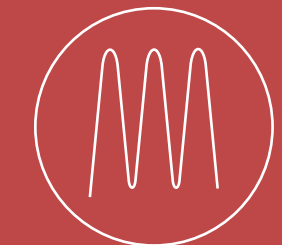

A

Higher Intensity

Digital

Analogue



Delta Theta Beta Alpha Gamma

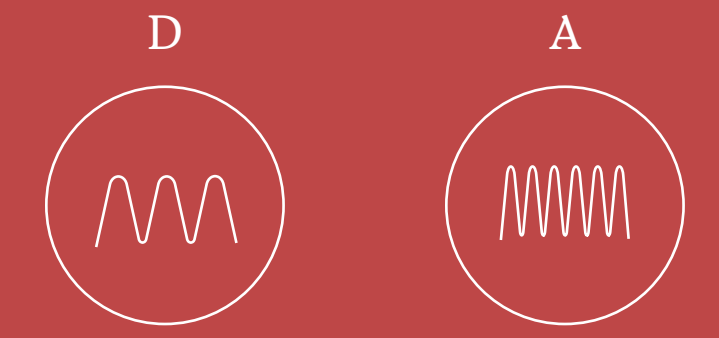

Greater frequency

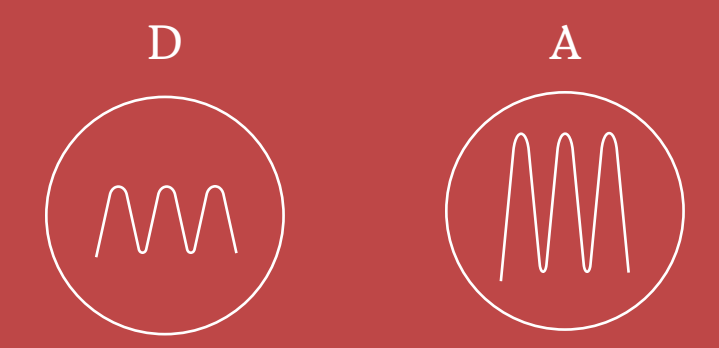

Higher Intensity

What was the main drawback?

The Bi-modality of *flow*

The Bi-modality of *flow*



Charles Darwin's path for *social flow*

The Bi-modality of *flow*

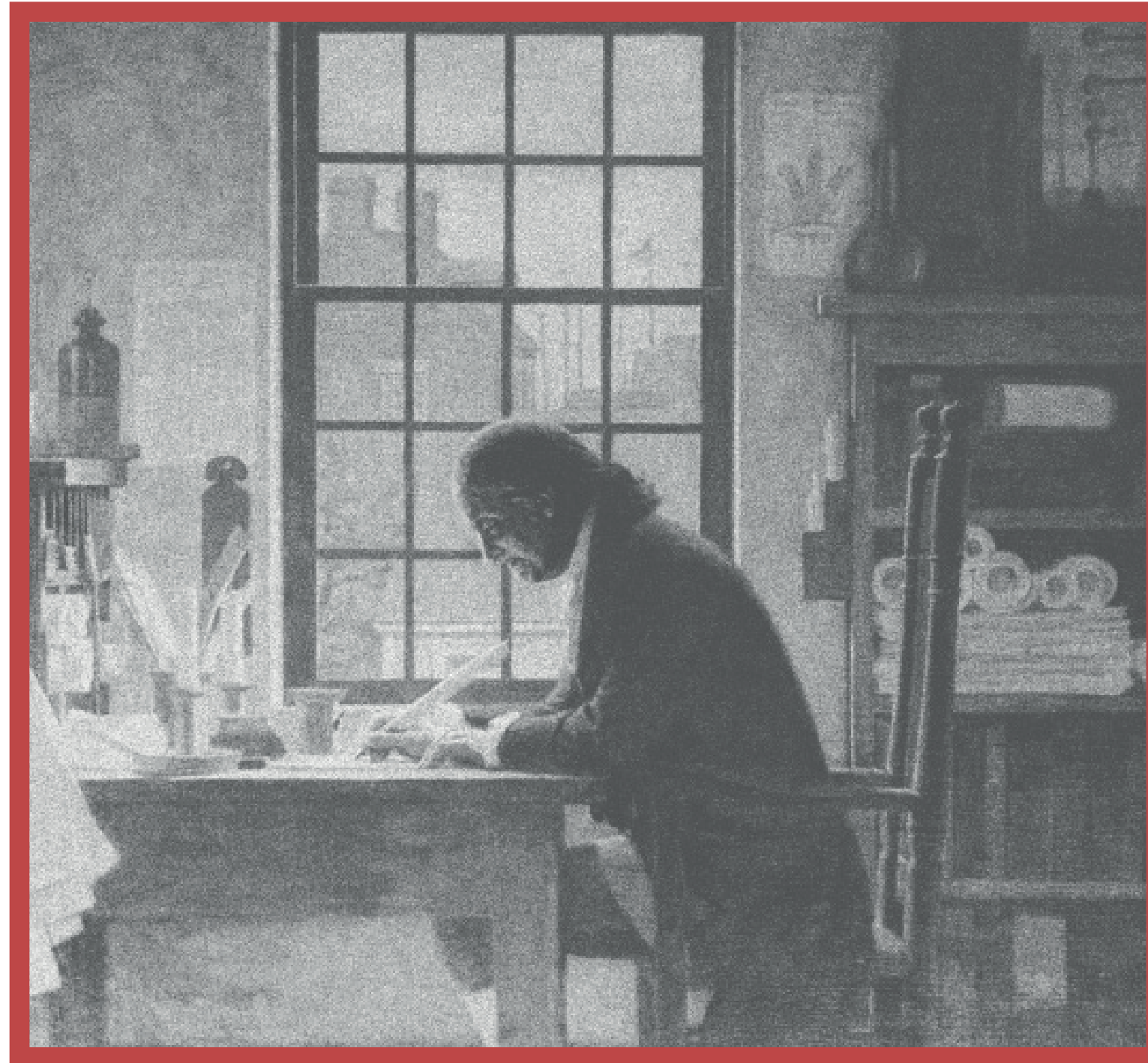

Benjamin Franklin in a *solitary flow* session

The Bi-modality of *flow*

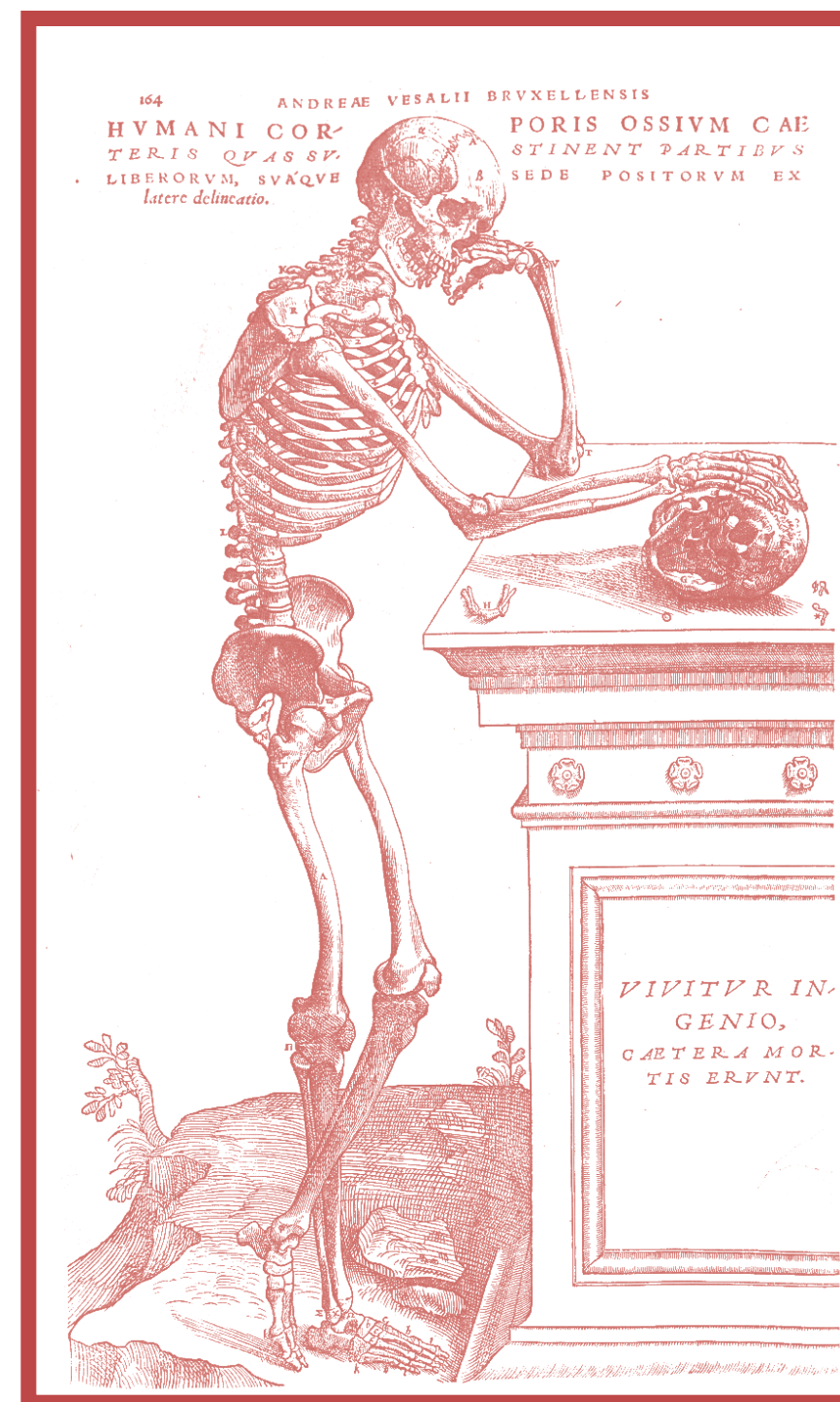
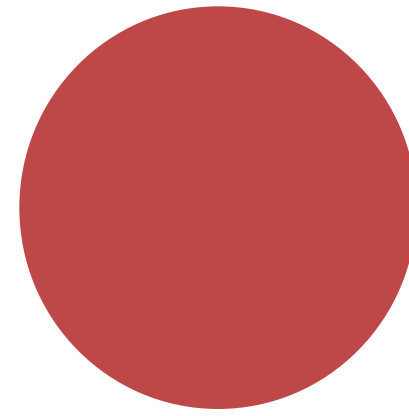

Andreas Vesalius
De Humani Corporis Fabrica, 1543

Design Proposals



Neuroarchitecture Research Centre in Delft, Netherlands
February 2021

2.

Neuroscience & Architecture

Part 2 illustrates the reasoning behind the project typology and the site.

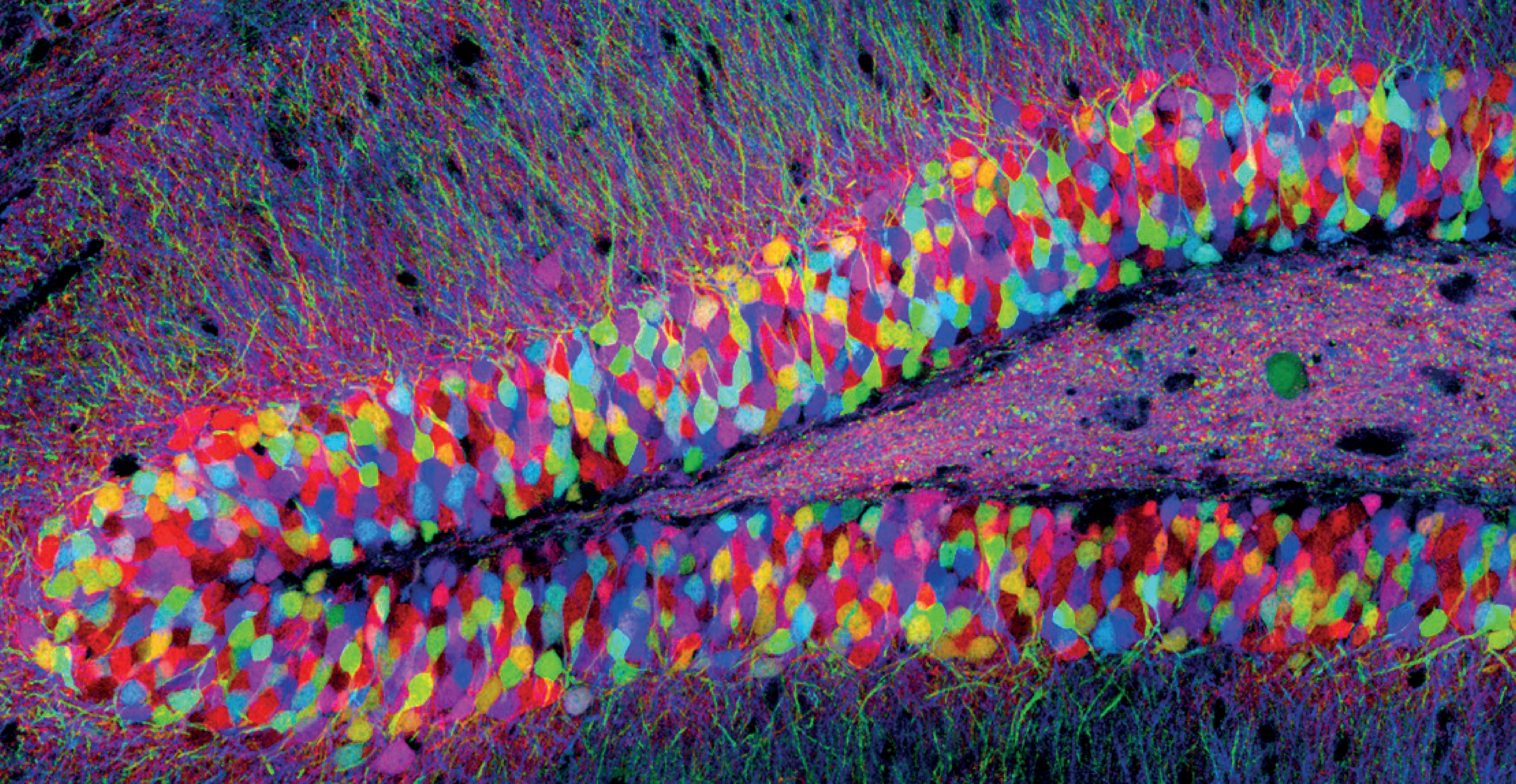

The Brainbow

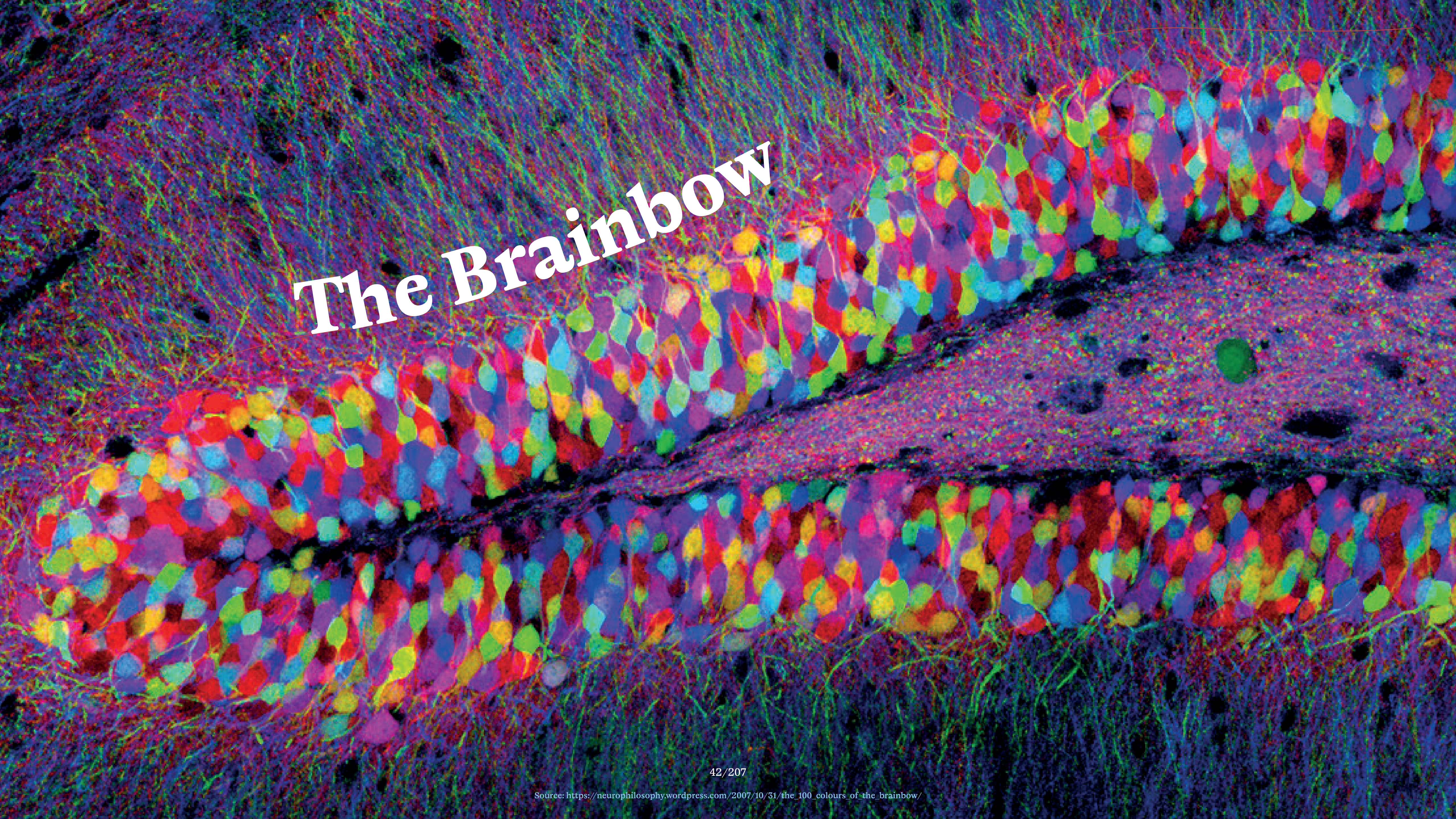

<<It is no exaggeration to say that we have learned more about our biological selves in the past half-century than in all of human history, and as a result of these developments, the humanities—sociology, philosophy, psychology, and human palaeontology in particular—have been forced to restructure their premises and research agendas radically. Yet architects have remained surprisingly incurious or seem little moved by these events.>>

Harry Mallgrave
Mind in Architecture, 2015, p. 18

References

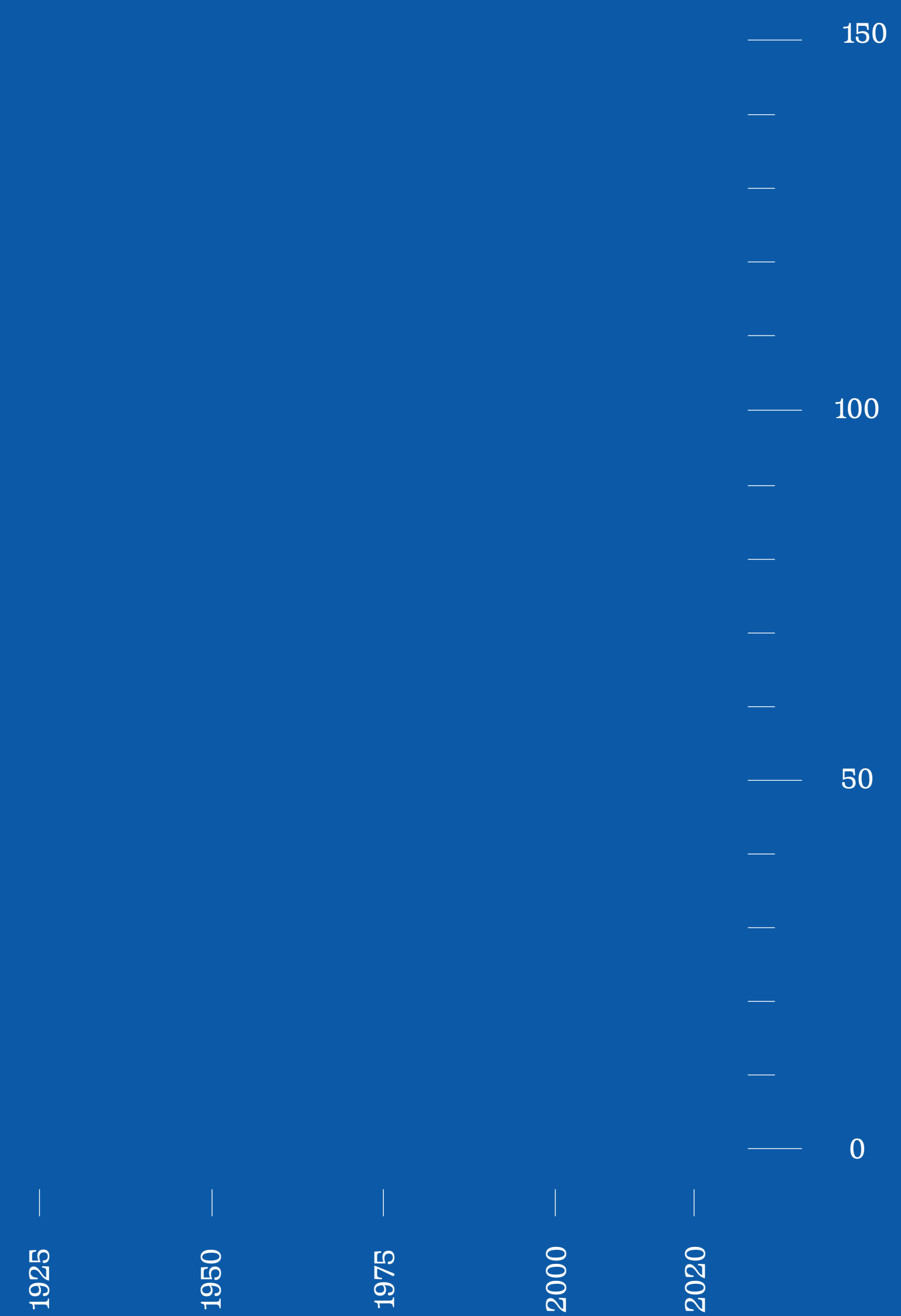

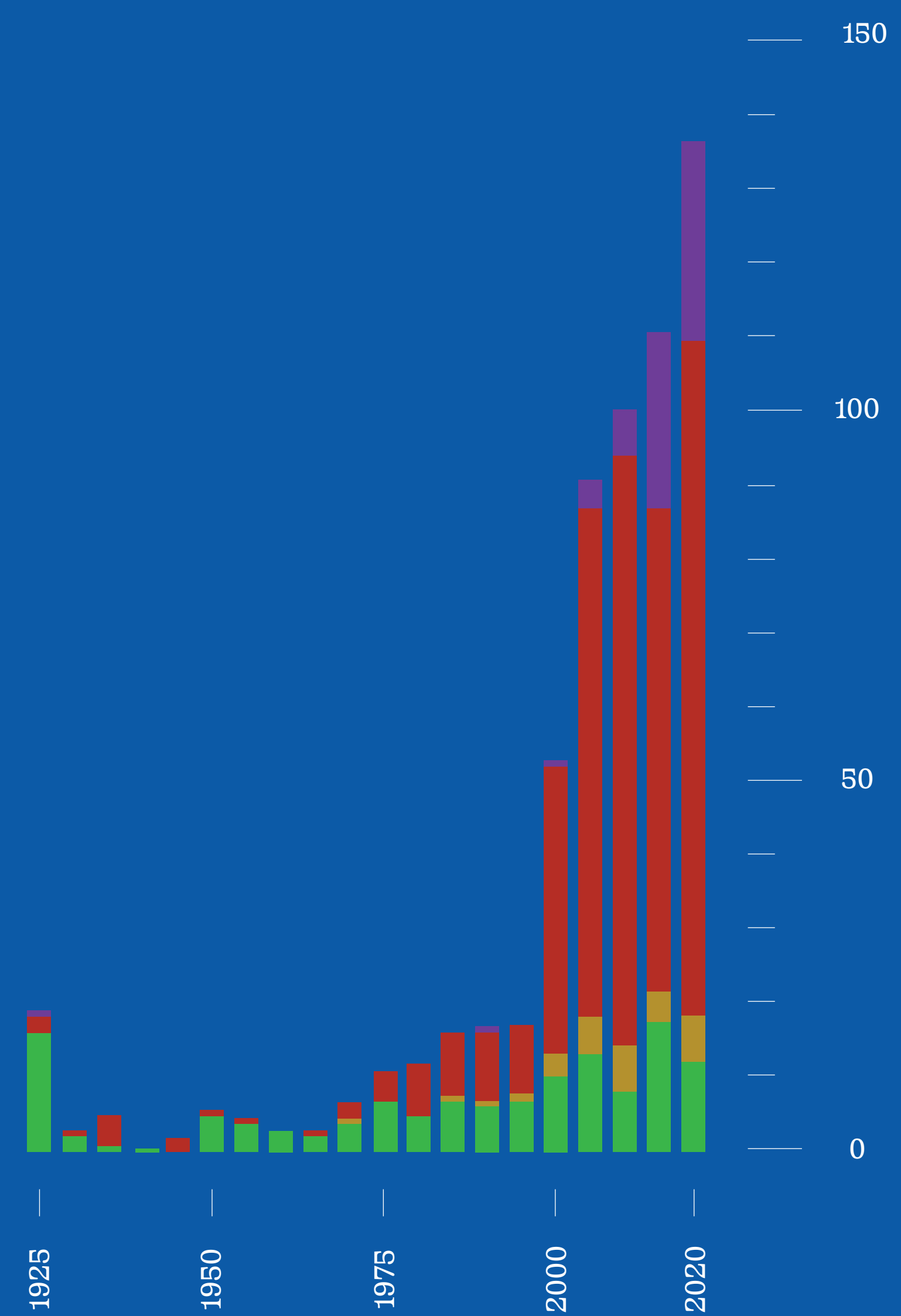

141 of the 612 published sources over the last 100 years explicitly examine the application of neuroscience to architecture.

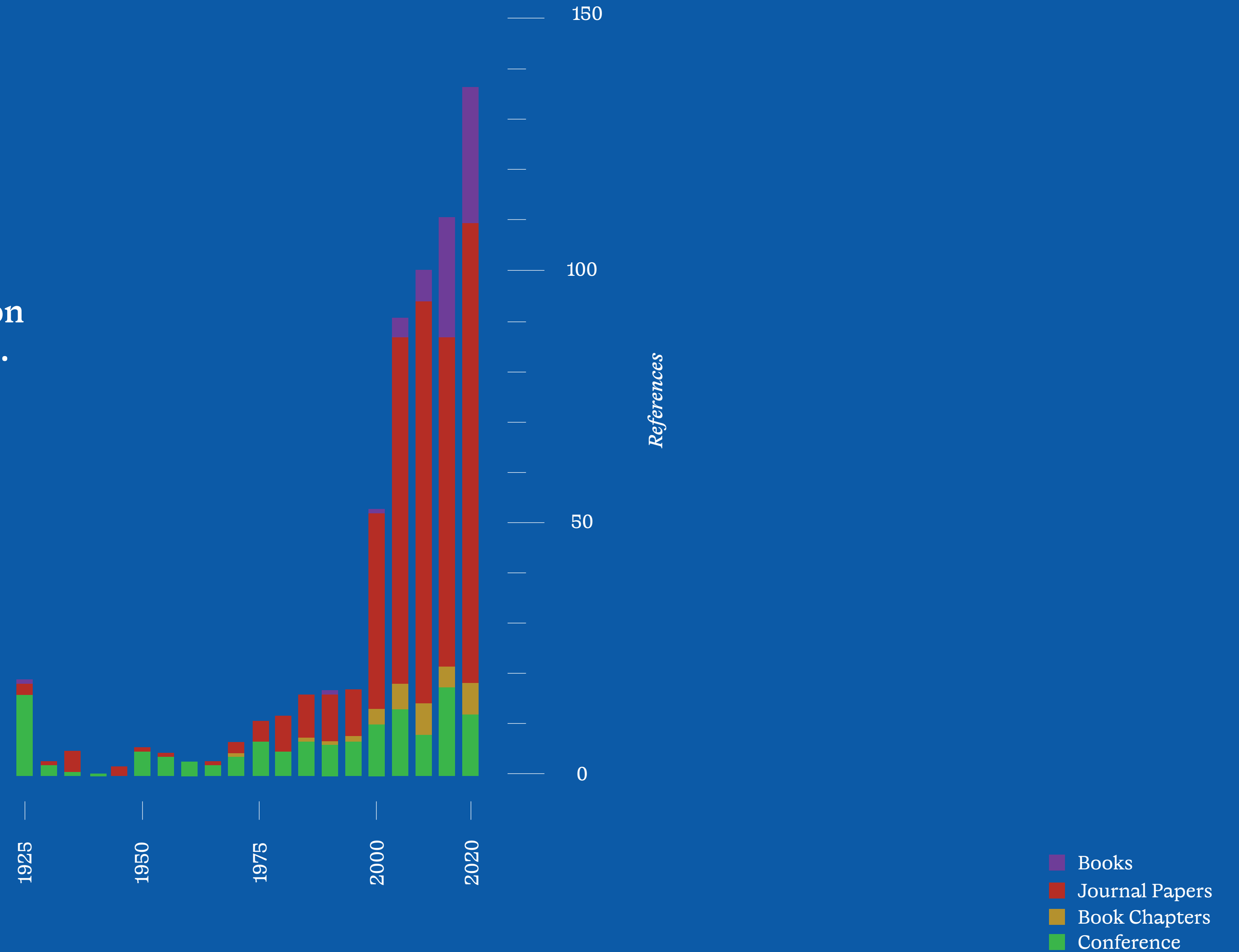

Mapping of Neuroarchitecture



Steve Waterman
Waterman butterfly projection, 1996

Mapping of Neuroarchitecture



Steve Waterman
Waterman butterfly projection, 1996

Mapping of Neuroarchitecture



Steve Waterman
Waterman butterfly projection, 1996

Mapping of Neuroarchitecture



Steve Waterman
Waterman butterfly projection, 1996

Mapping of Neuroarchitecture



Steve Waterman
Waterman butterfly projection, 1996

Mapping of Neuroarchitecture



Steve Waterman
Waterman butterfly projection, 1996

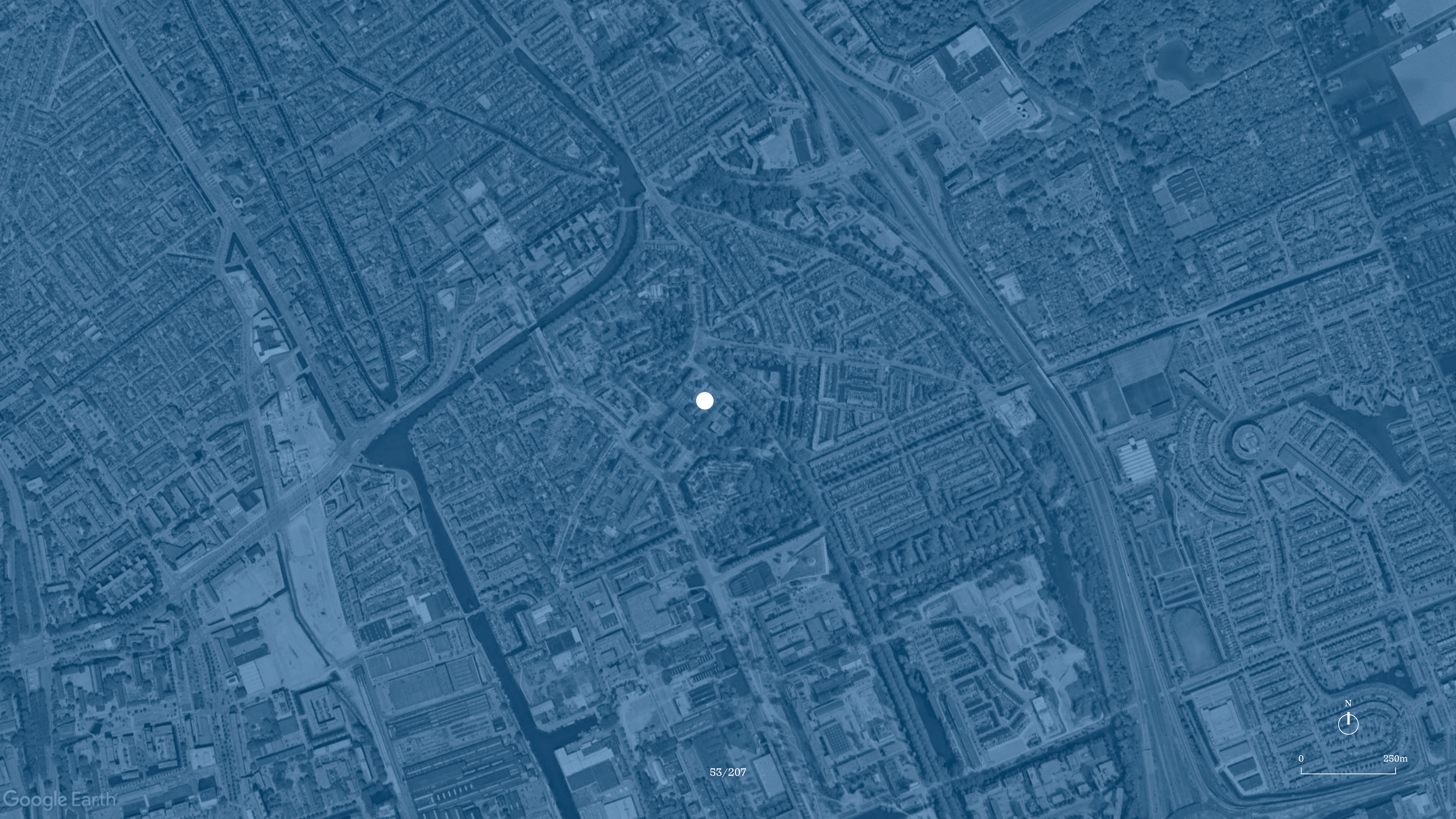



Rode Scheikunde

Zuidplantsoen

Gele Scheikunde





5253 m²

55/207





New parking lot

56/207



0 50m

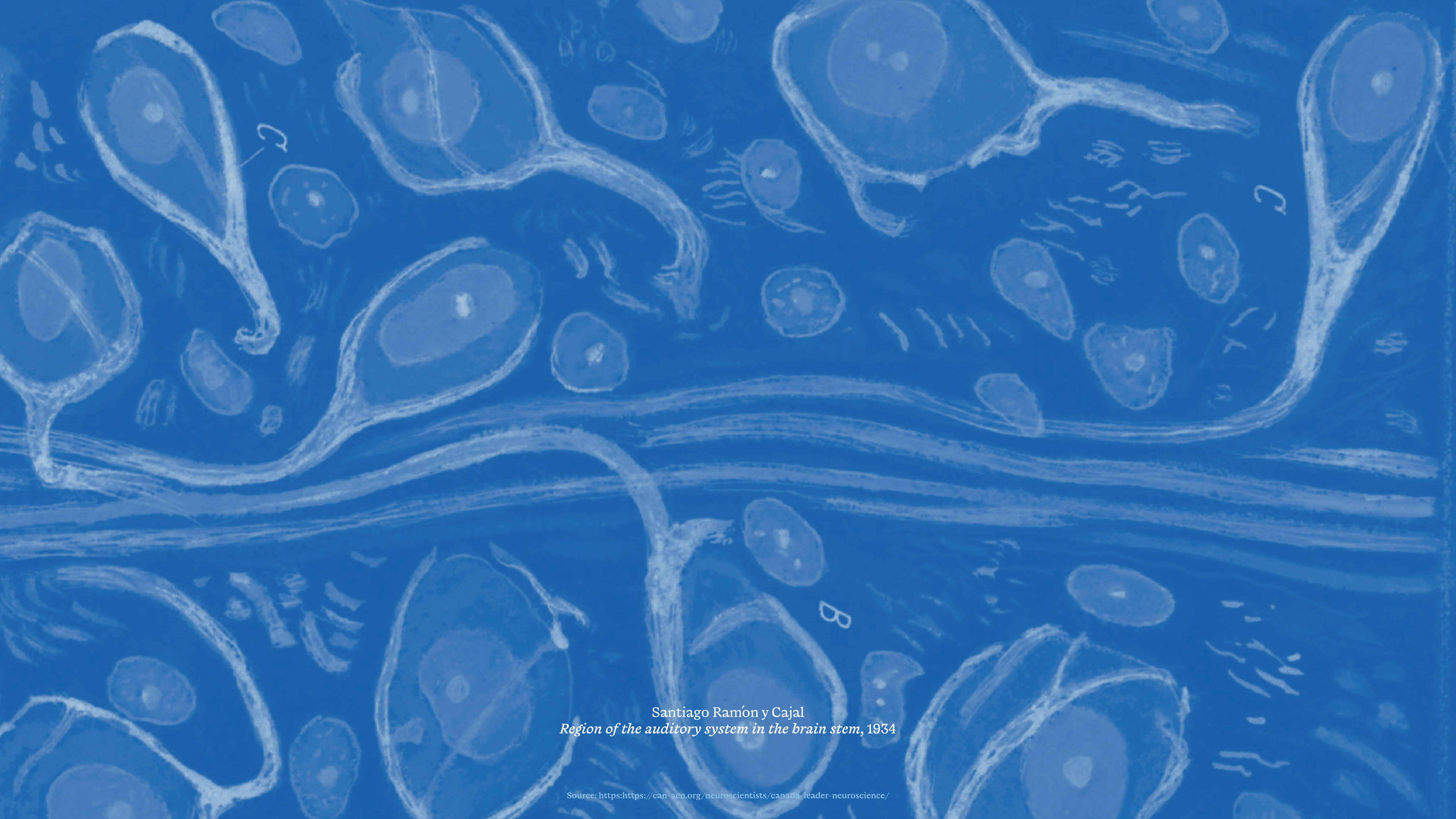

Santiago Ramón y Cajal
Region of the auditory system in the brain stem, 1934

3.

A Living Lab for Flow

Part 3 illustrates the concept and program of the neuroscience research centre.

Santiago Ramón y Cajal
Region of the auditory system in the brain stem, 1934

Concept

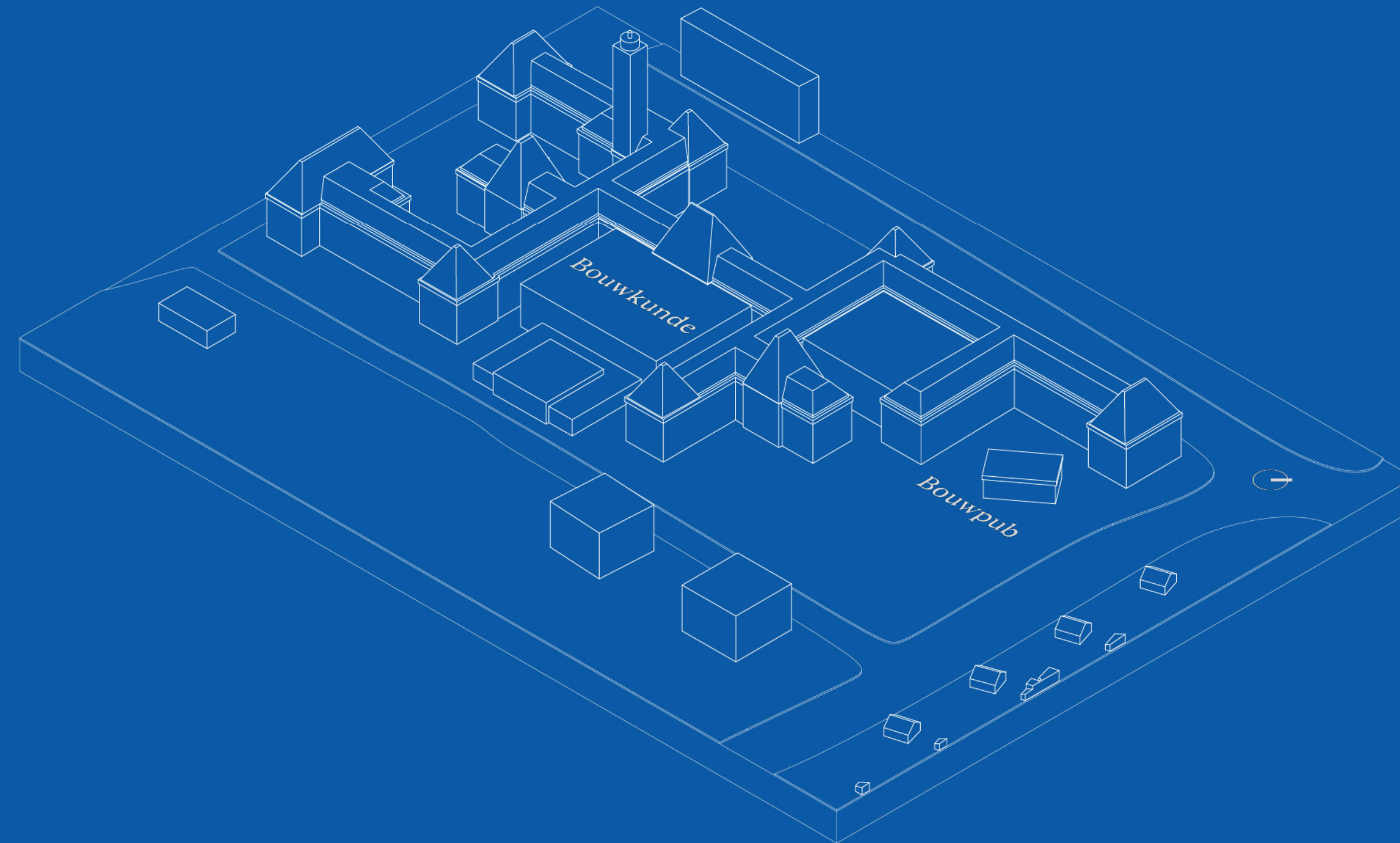

Concept

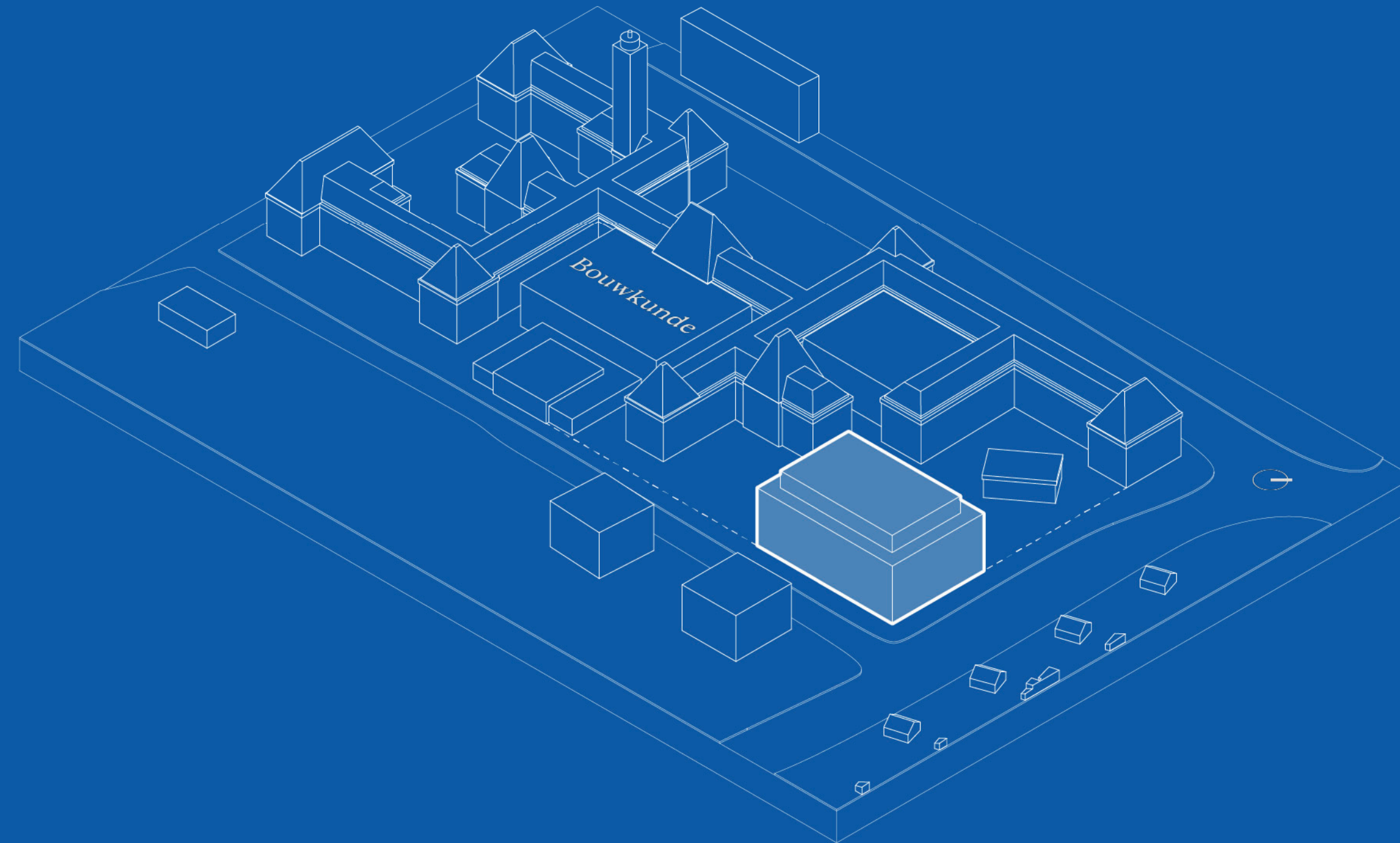

Concept

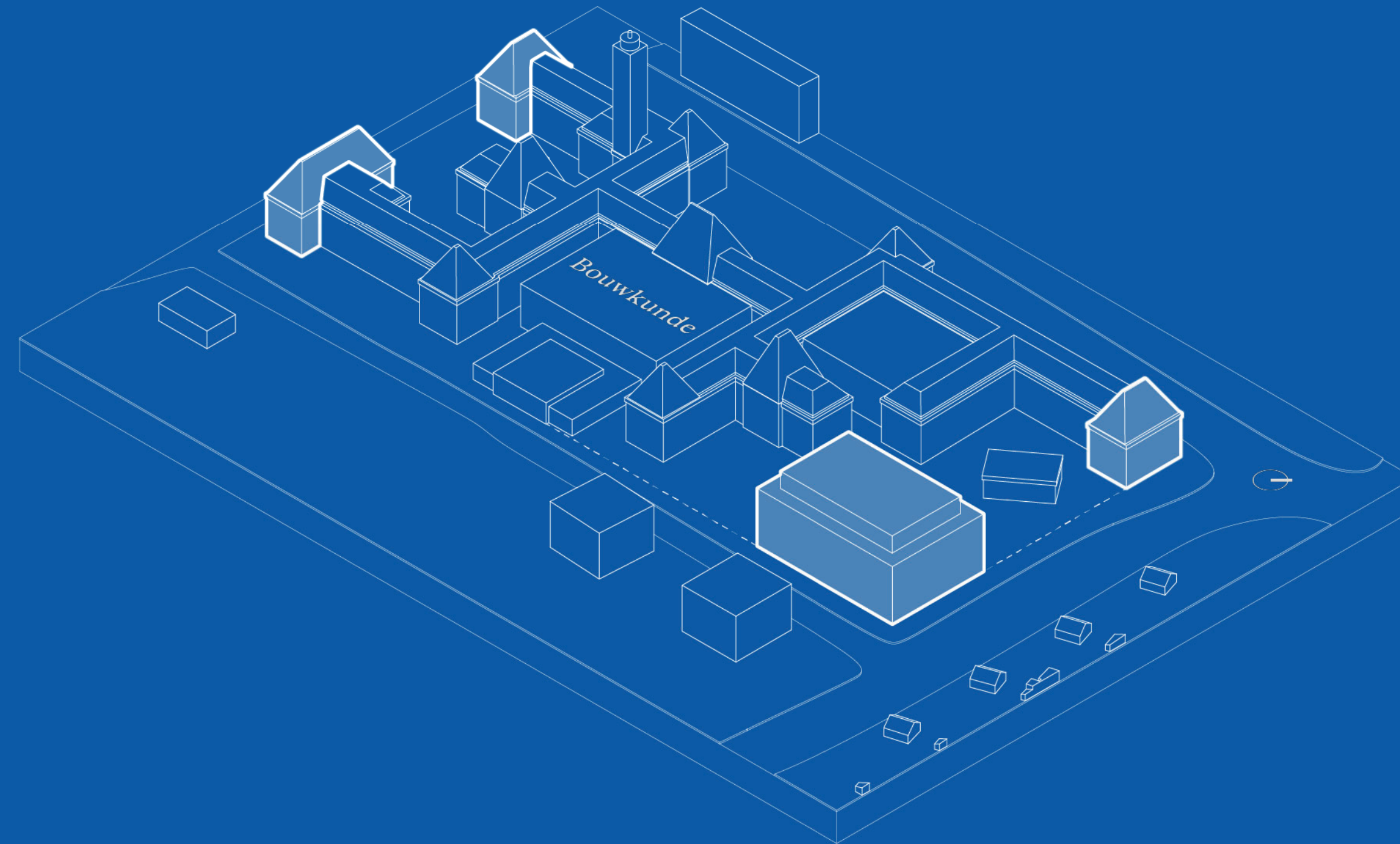

Keywords

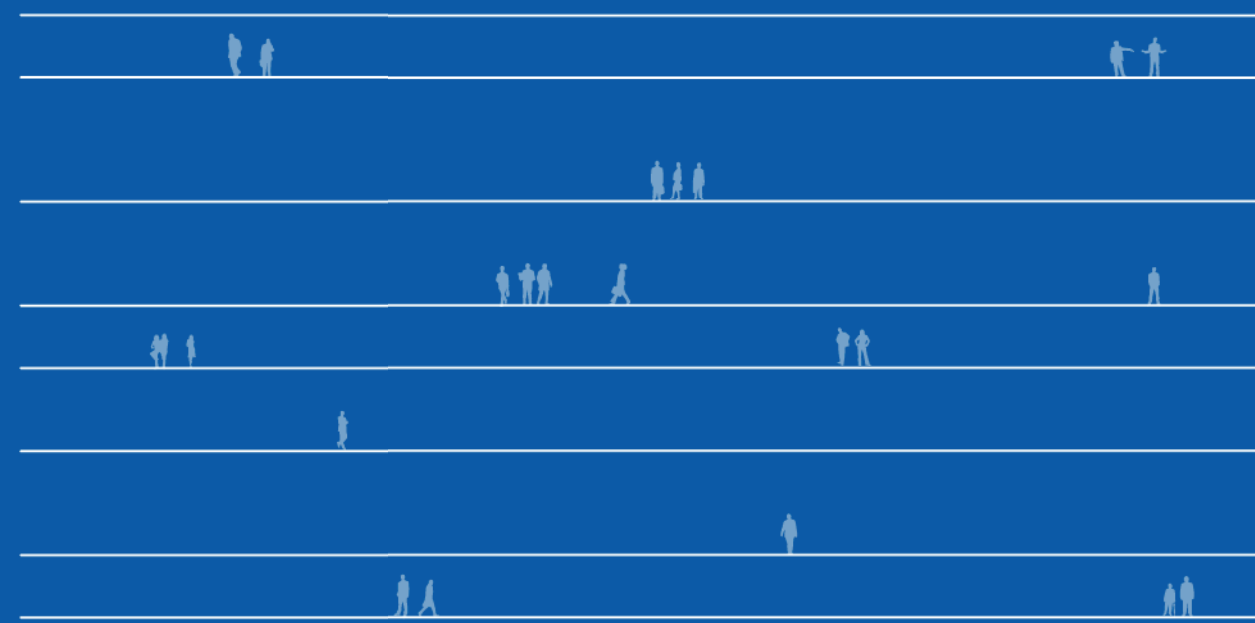

Simple stacked

Keywords

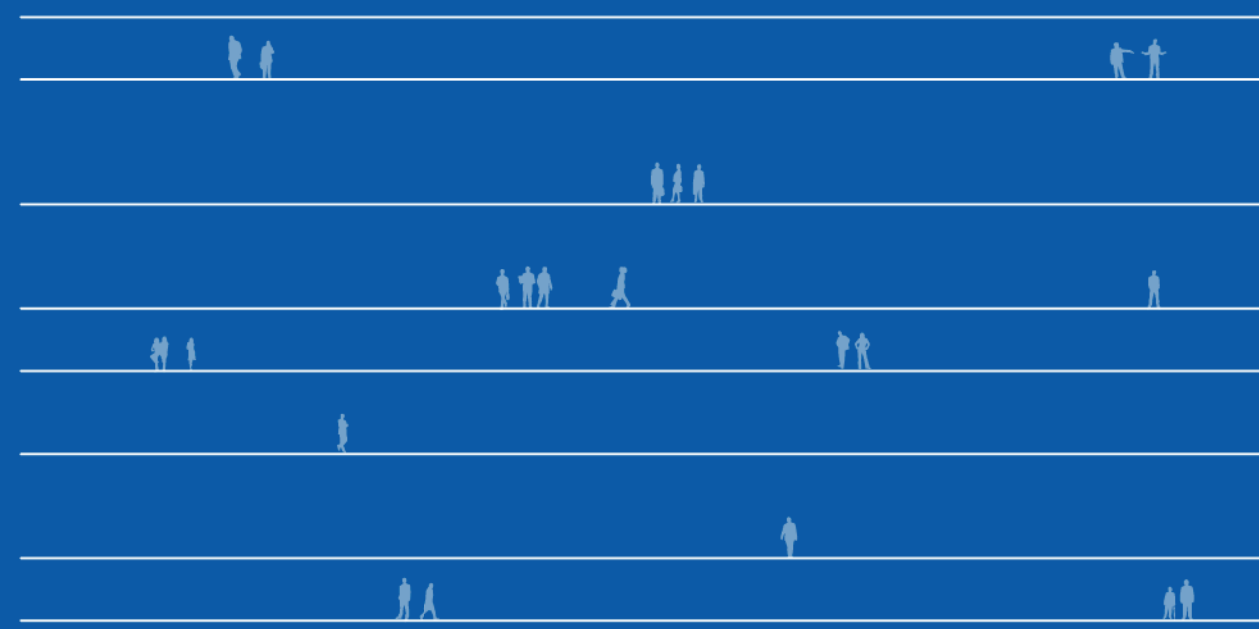

Simple stacked

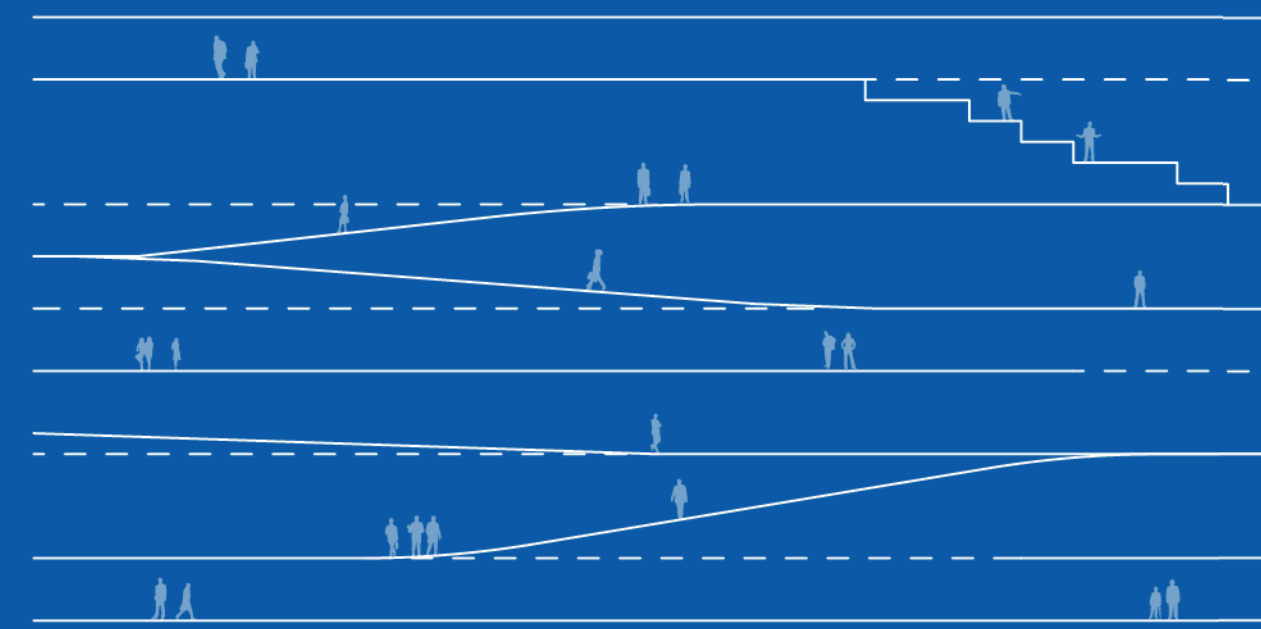

Promenade

Keywords



Simple stacked

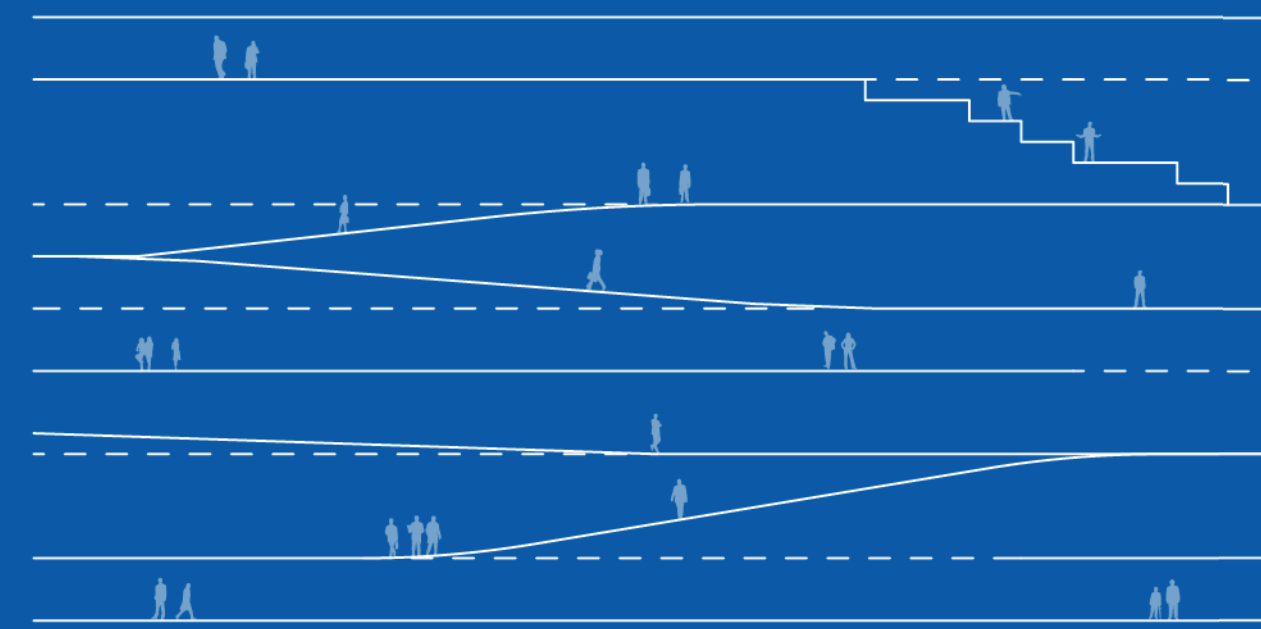

Promenade + Connexity

Perceptual Sketching

Perceptual Sketching



Childs drawing of a house

Perceptual Sketching

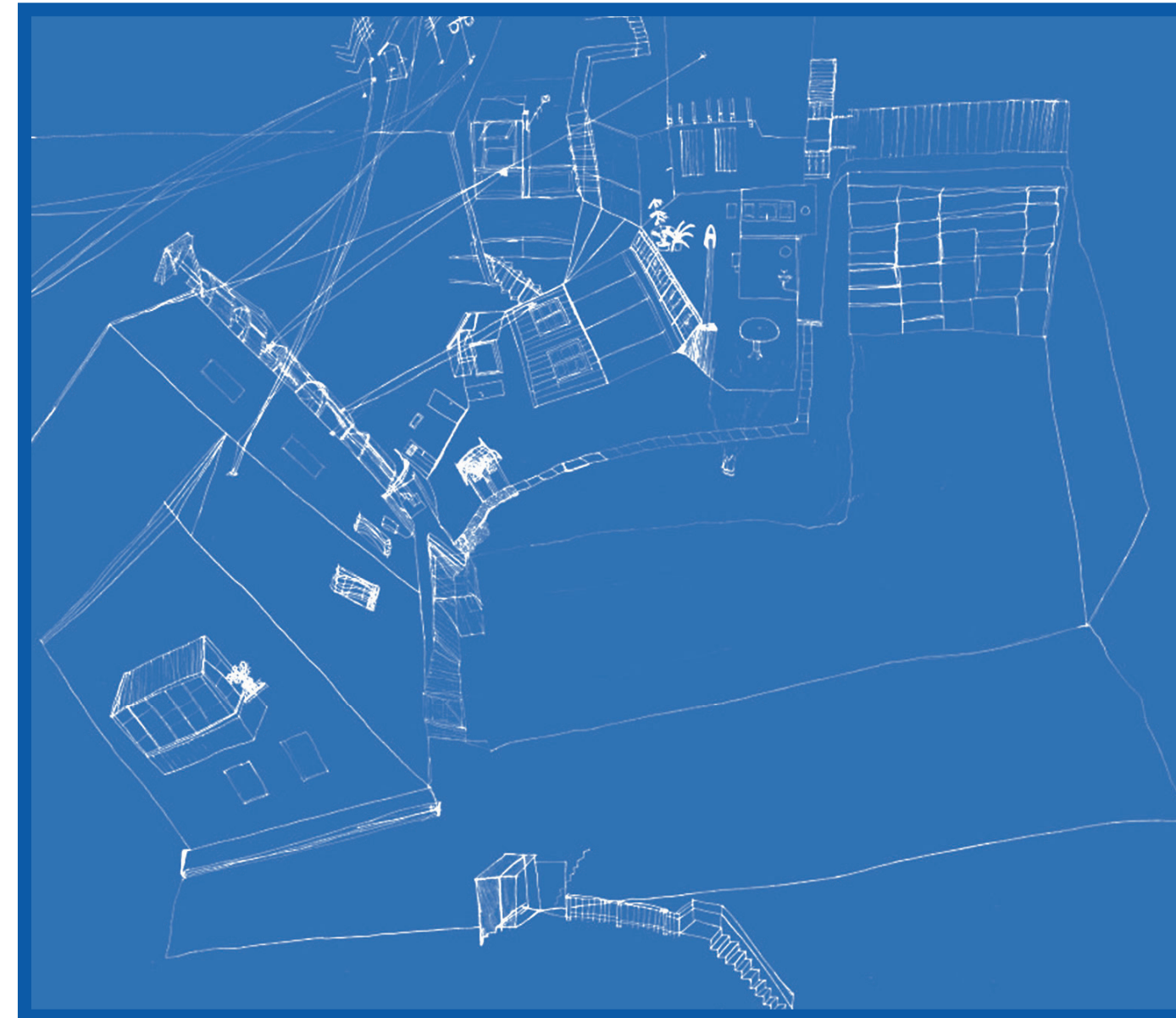

Childs drawing of their house

Perceptual Sketching



Rohan Shenoy
A case study of ECHO by UN Studio, 2022

Perceptual Sketching



Rohan Shenoy
Concept Sketch of Living Lab, 2022

Paper Models



Rohan Shenoy
Paper model iteration of Living Lab, 2022

Result of Design Studies

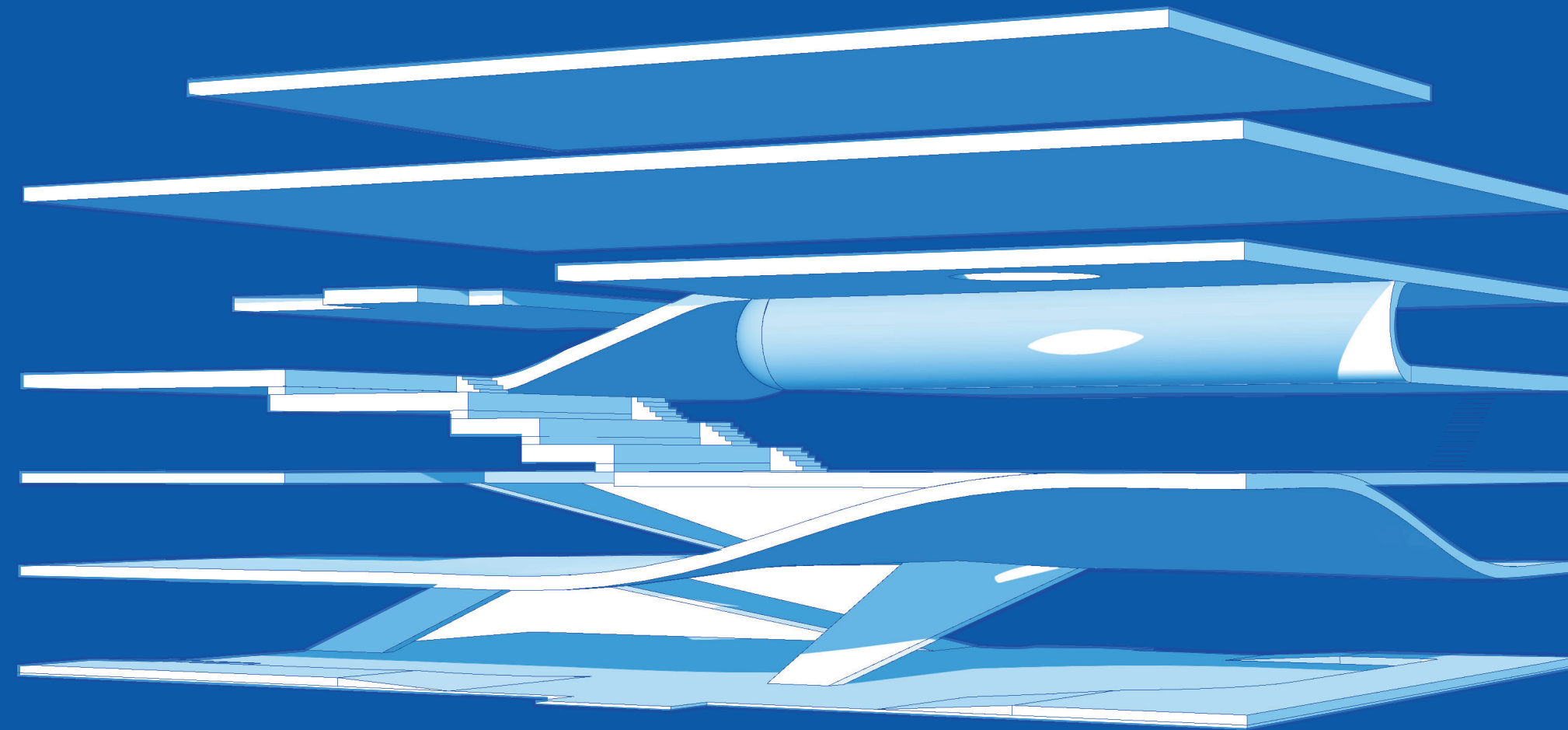

Horizontal disturbances in the stacked layers of the research centre

Eudaemonia



Raphael
The School of Athens, 1511

The Eudaemonic Machine

The Eudaemonic Machine

1.

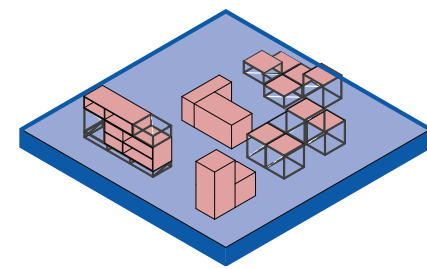

The Gallery

Inspiration
Motivation

The Eudaemonic Machine

2.

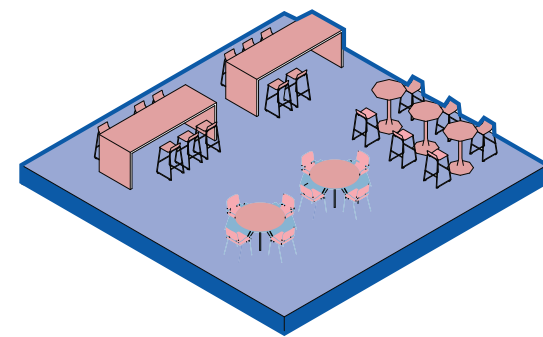

The Lounge

Social *flow*
Cooperation
Discussions
Curiosity

1.

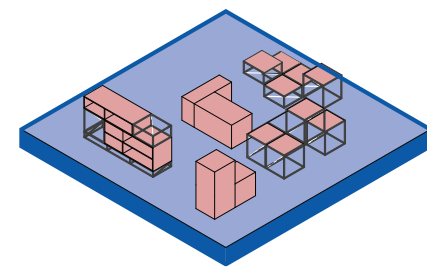

The Gallery

Inspiration
Motivation

The Eudaemonic Machine

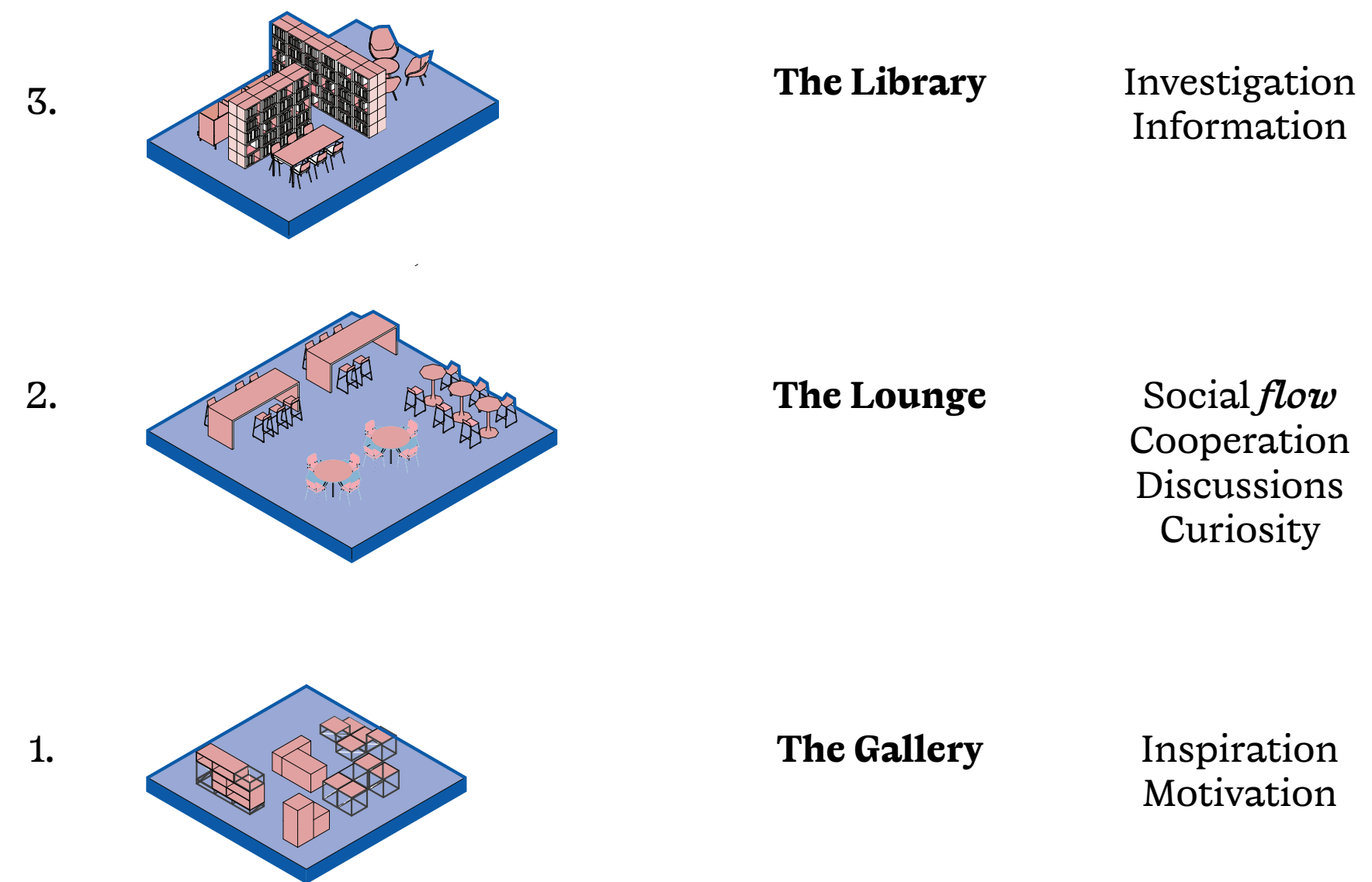

The Eudaemonic Machine

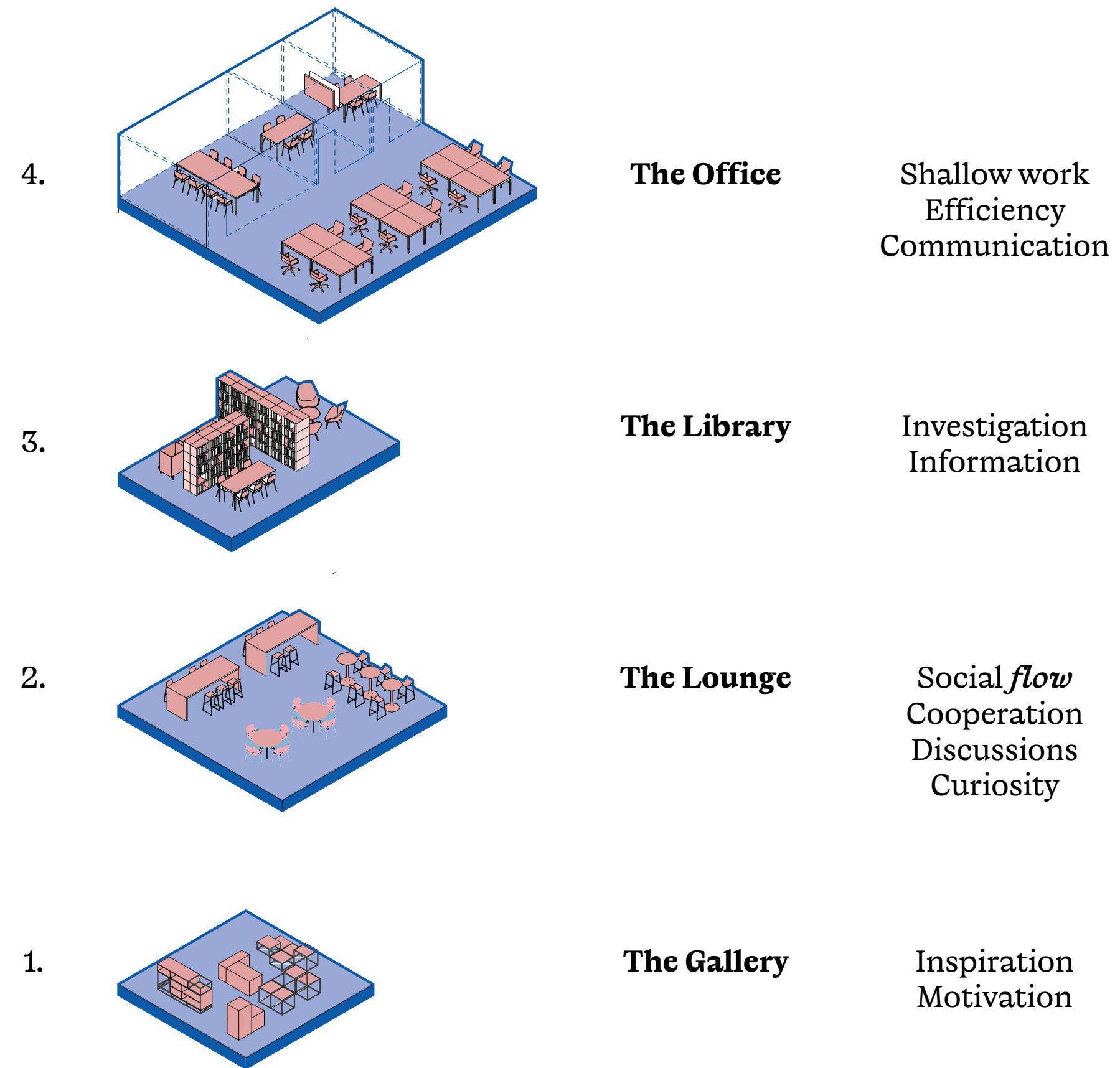

The Eudaemonic Machine

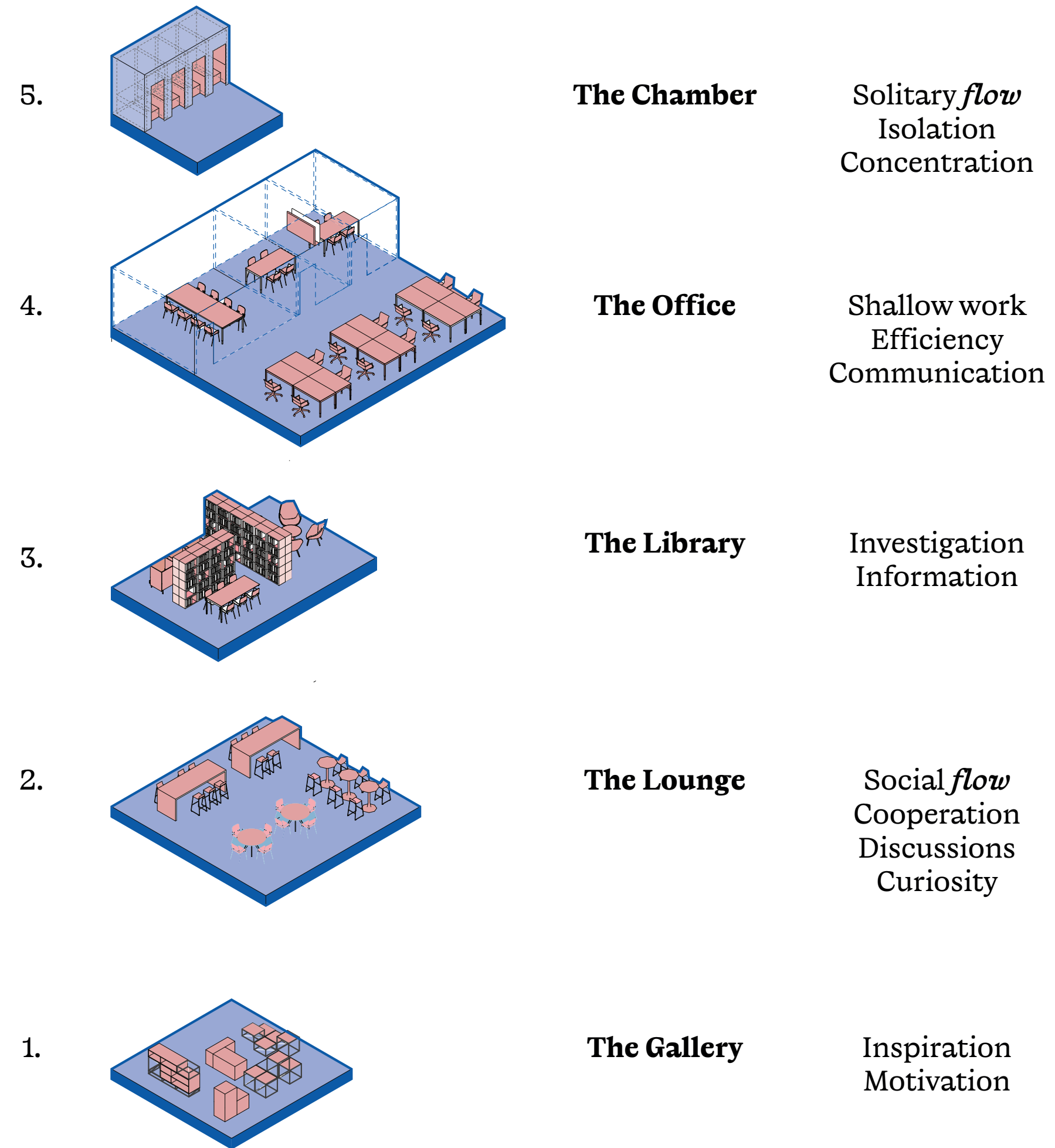

Bouwkunde

Bouwpub

Entrance



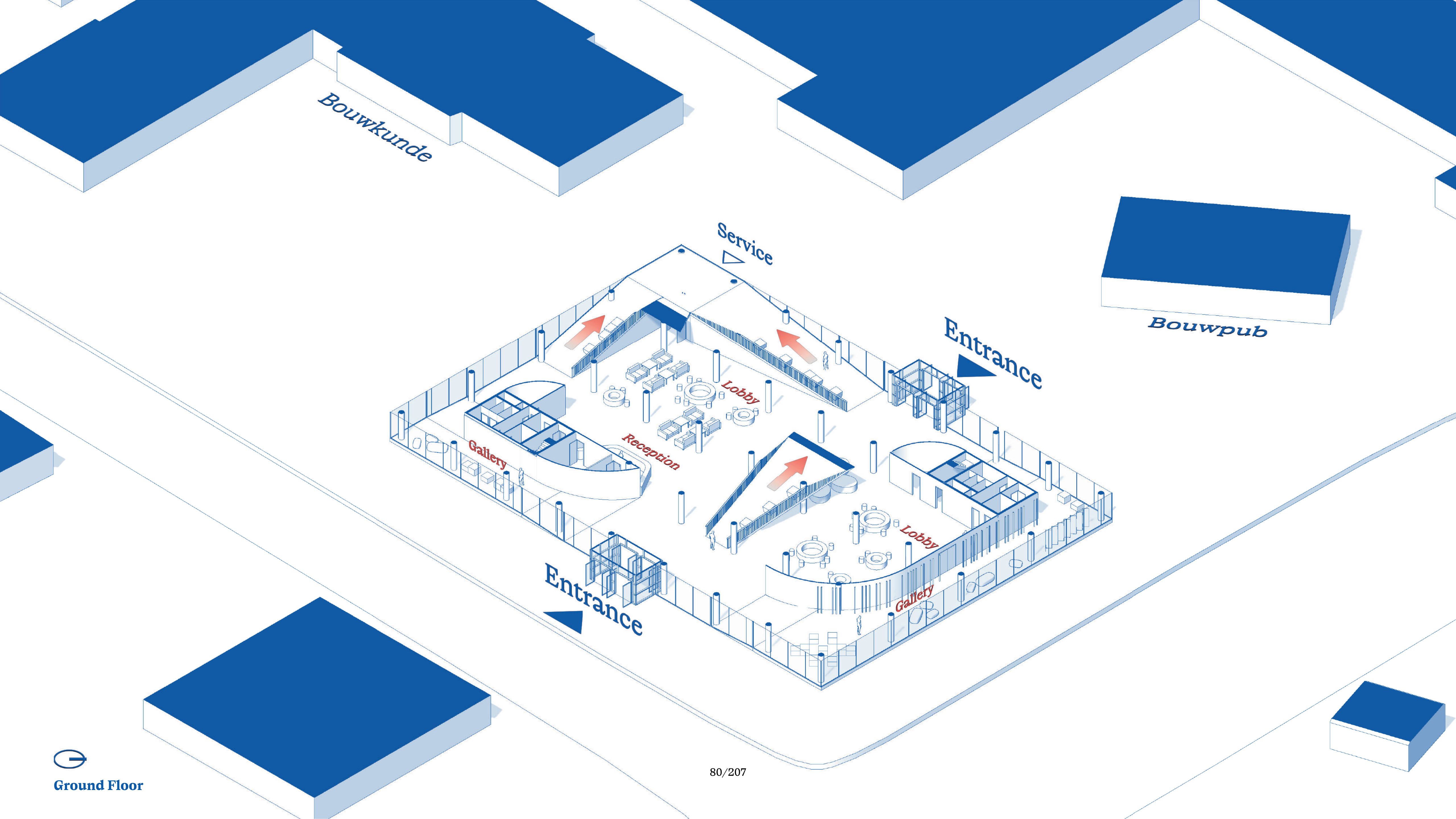

Bouwkunde

Bouwpub

Service

Entrance

Lobby

Reception

Gallery

Lobby

Entrance

Gallery



Ground Floor

The Gallery



Bouwkunde

Bouwpub

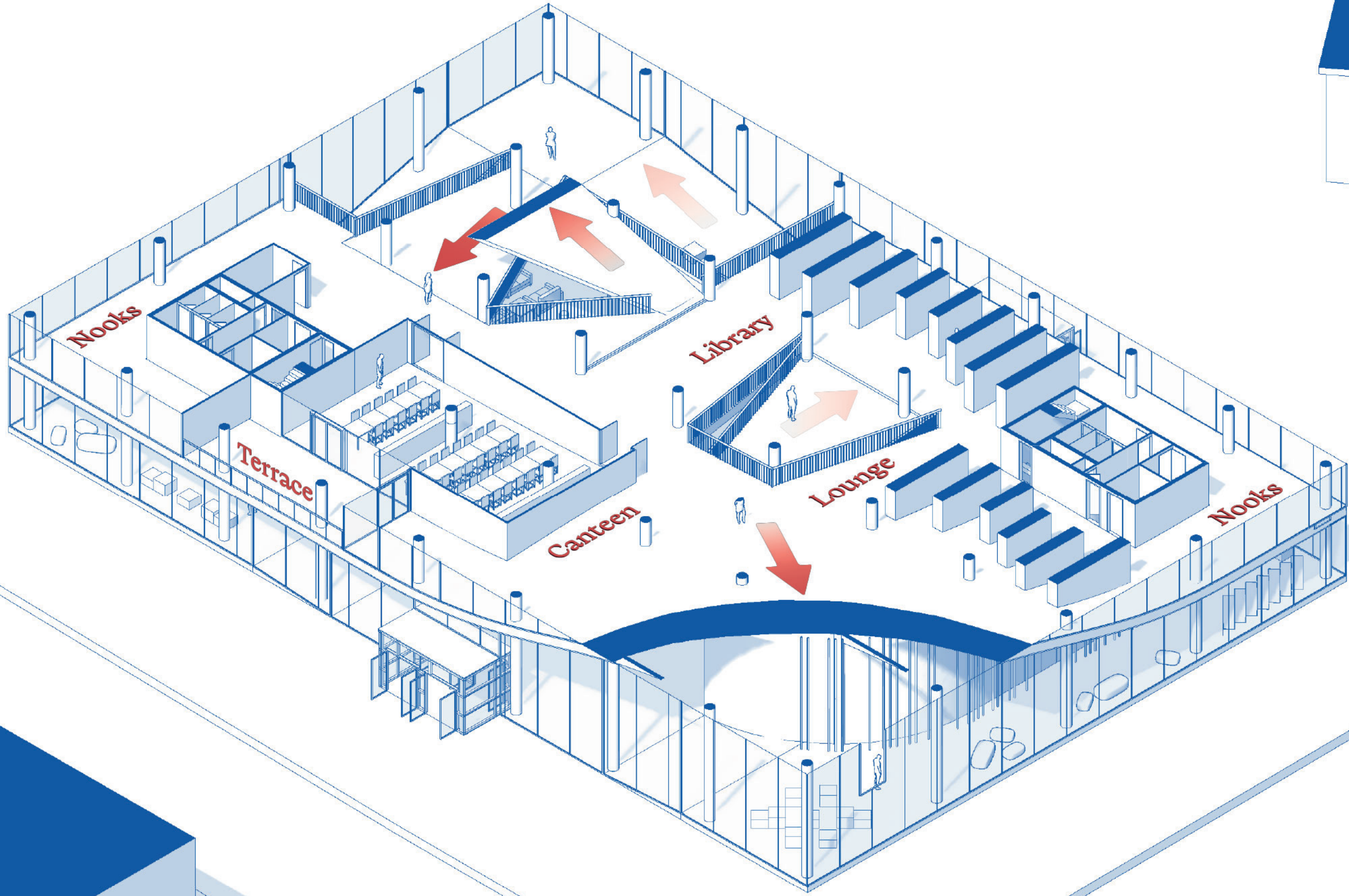

Level 1



Library at the Bouwkunde

Bouwkunde

Bouwpub

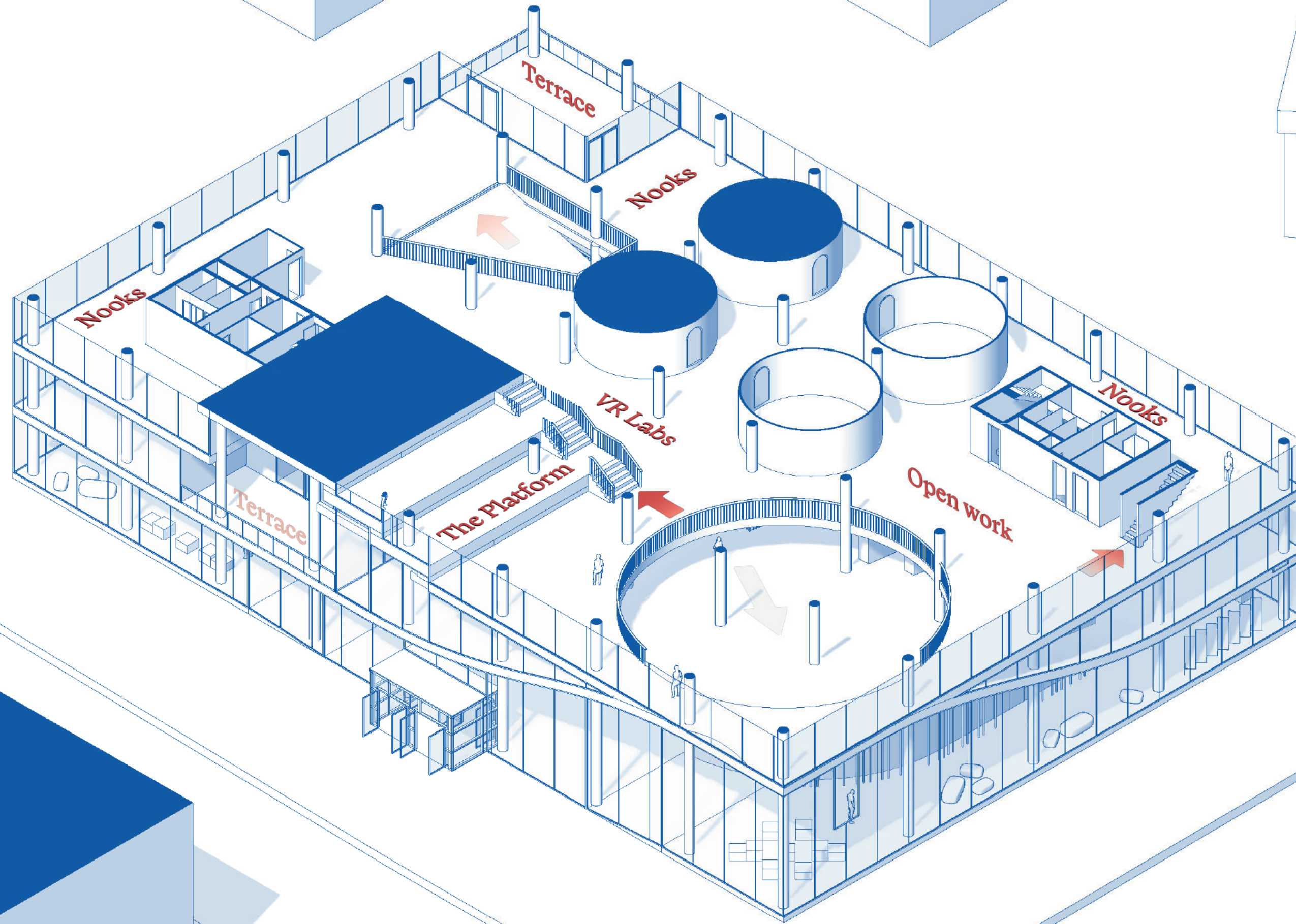

Level 2

Open Work Space



The Platform



Bouwkunde

Bouwpub

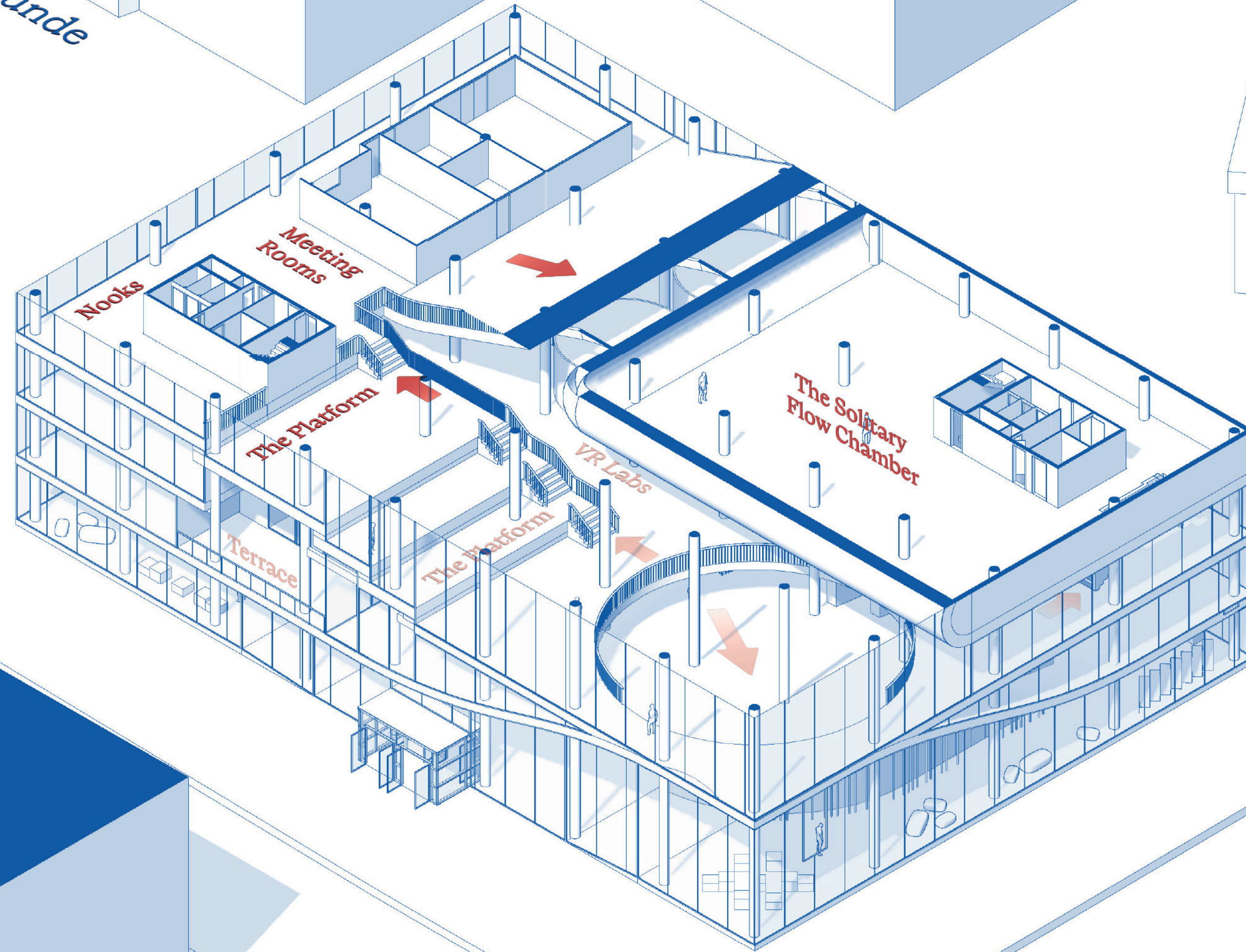

Level 3

Solitary Flow Chamber



Solitary Flow Cave



Bouwkunde

The Command Centre

Hostia

Bouwpub

Faculty Office

Terrace

Terrace



Level 4

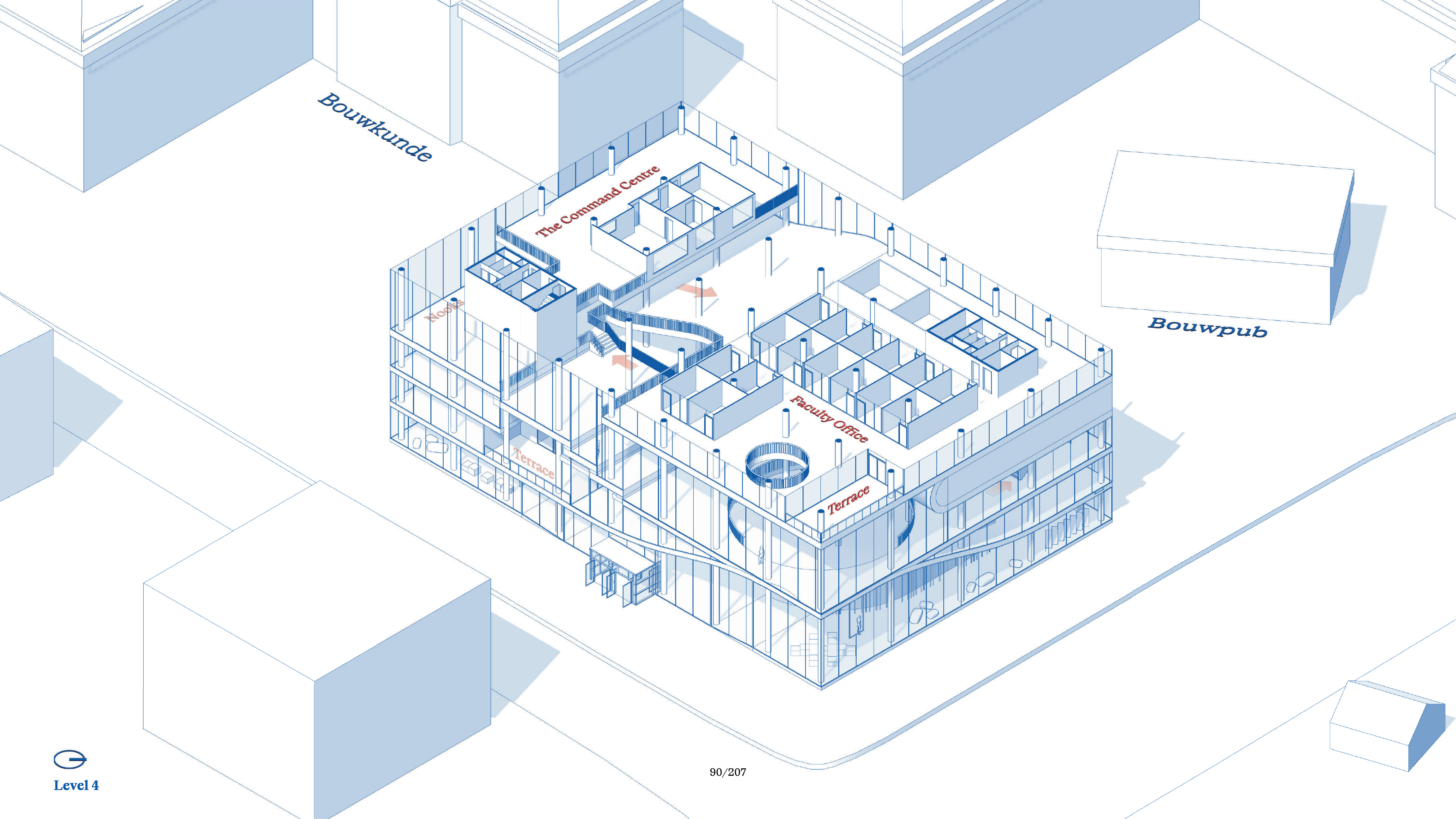

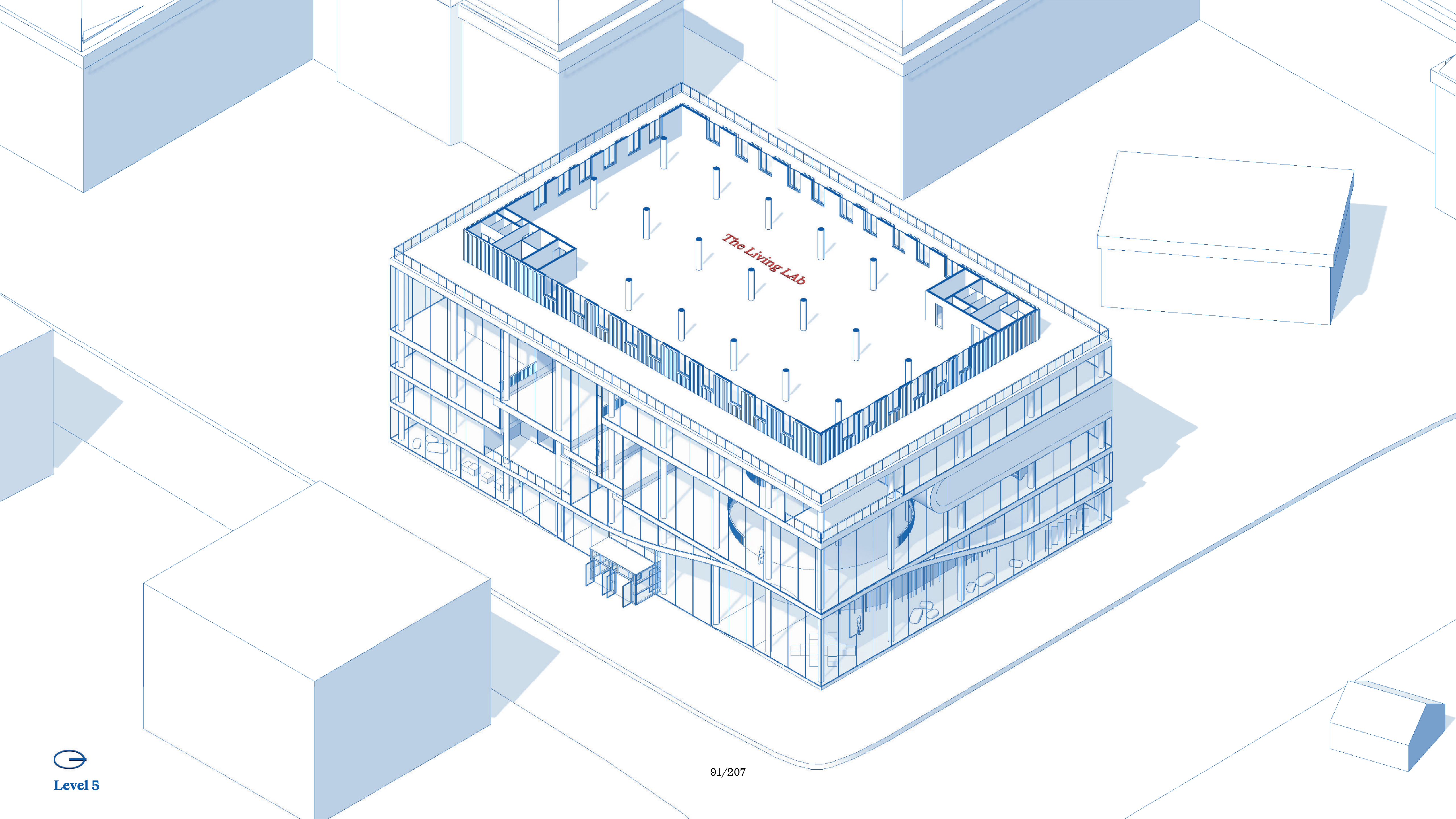

The Living Lab



Level 5

The Living Lab



Timber



Timber



Timber

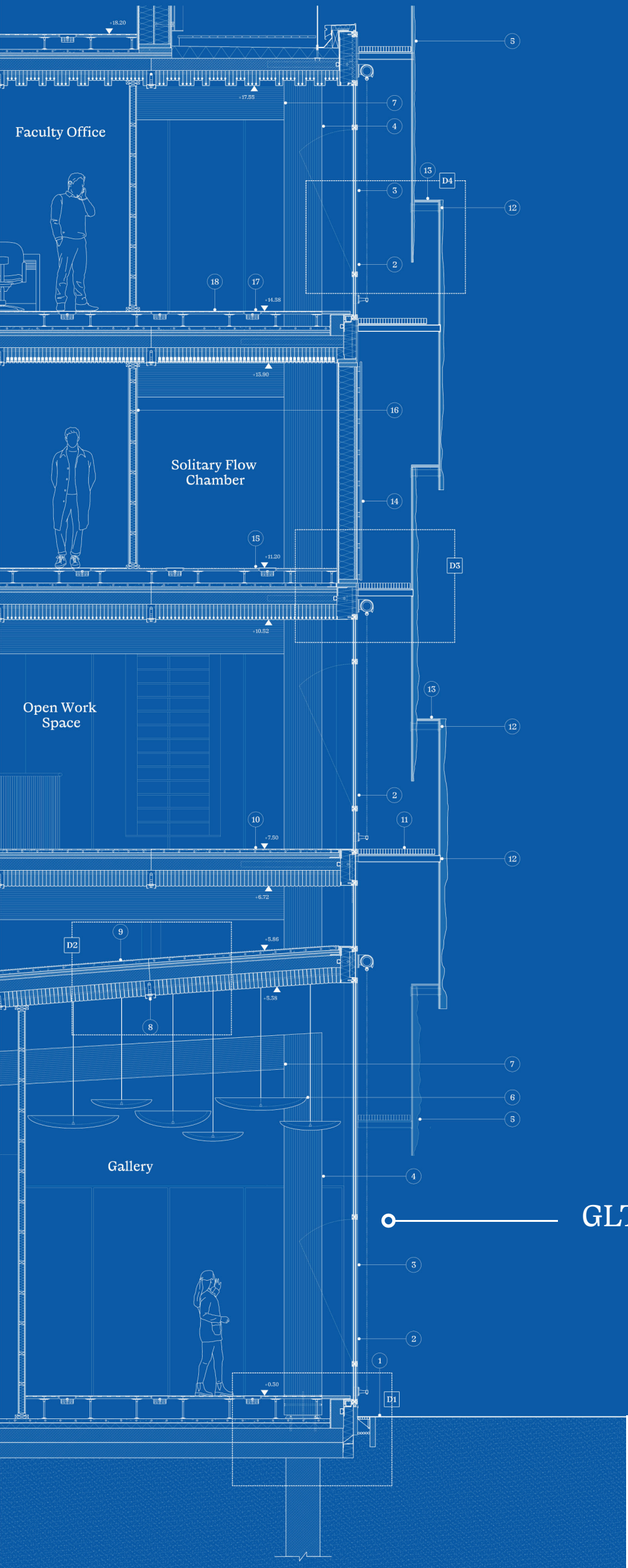
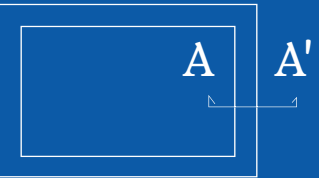

GLT post and beam system

Timber

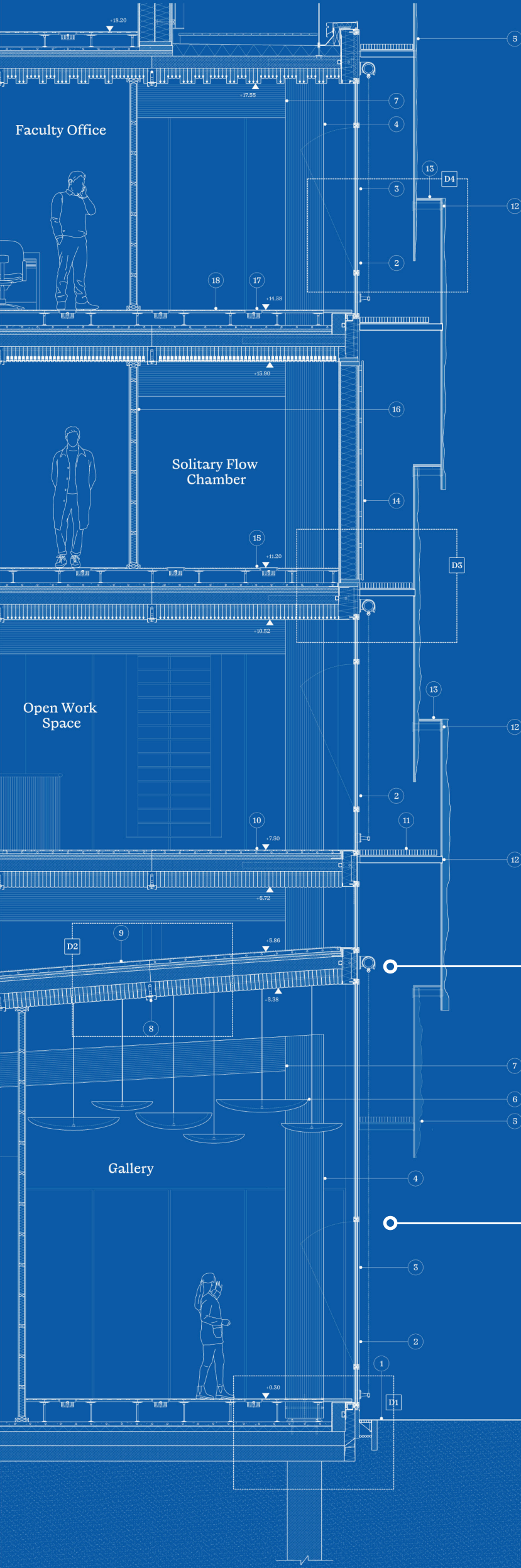
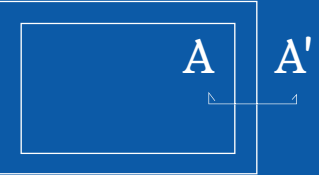

DLT ceiling in a TCC slab system

GLT post and beam system

Dowel Laminated Timber

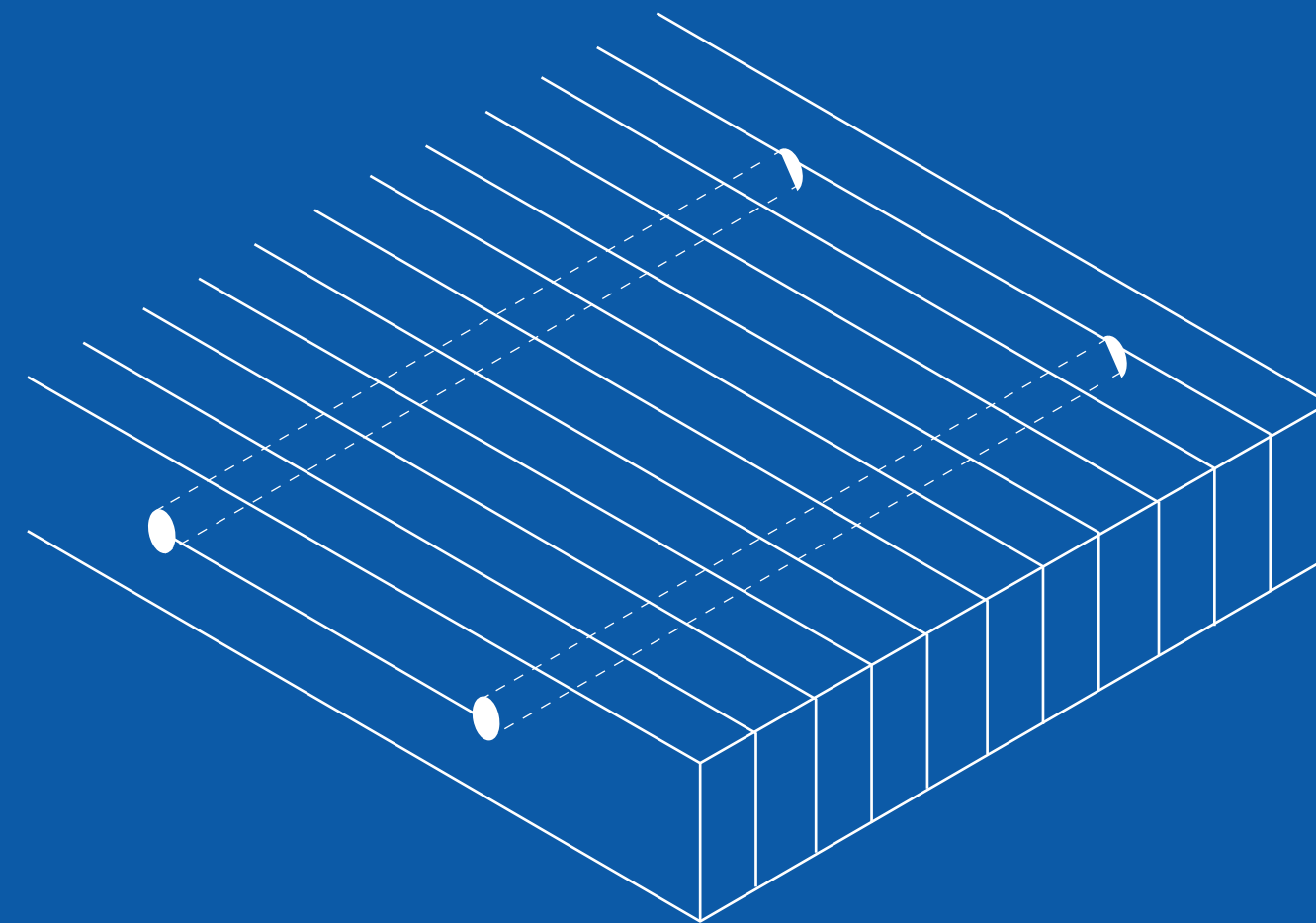

The use of wooden dowels rather than nails or glue

Dowel Laminated Timber

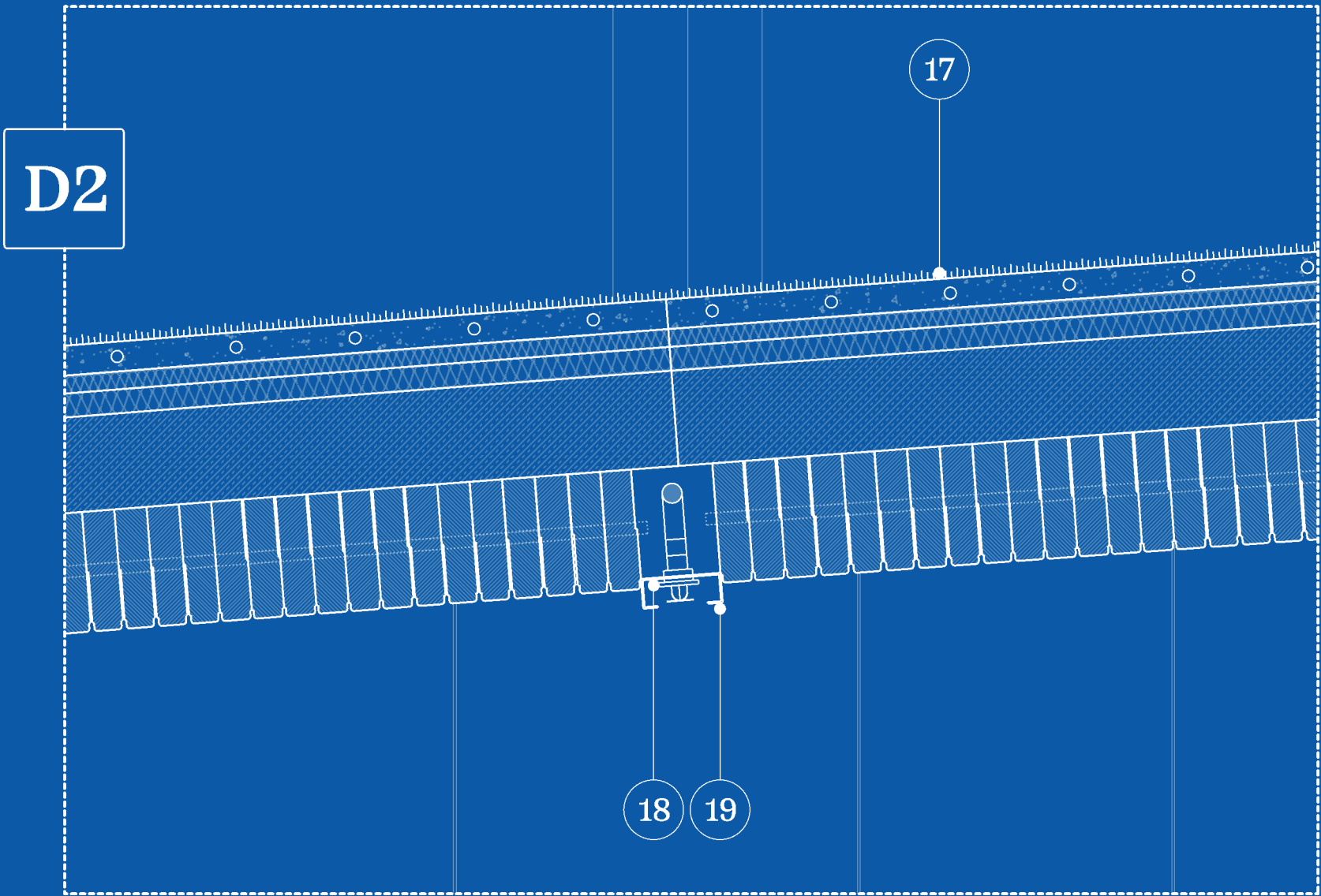
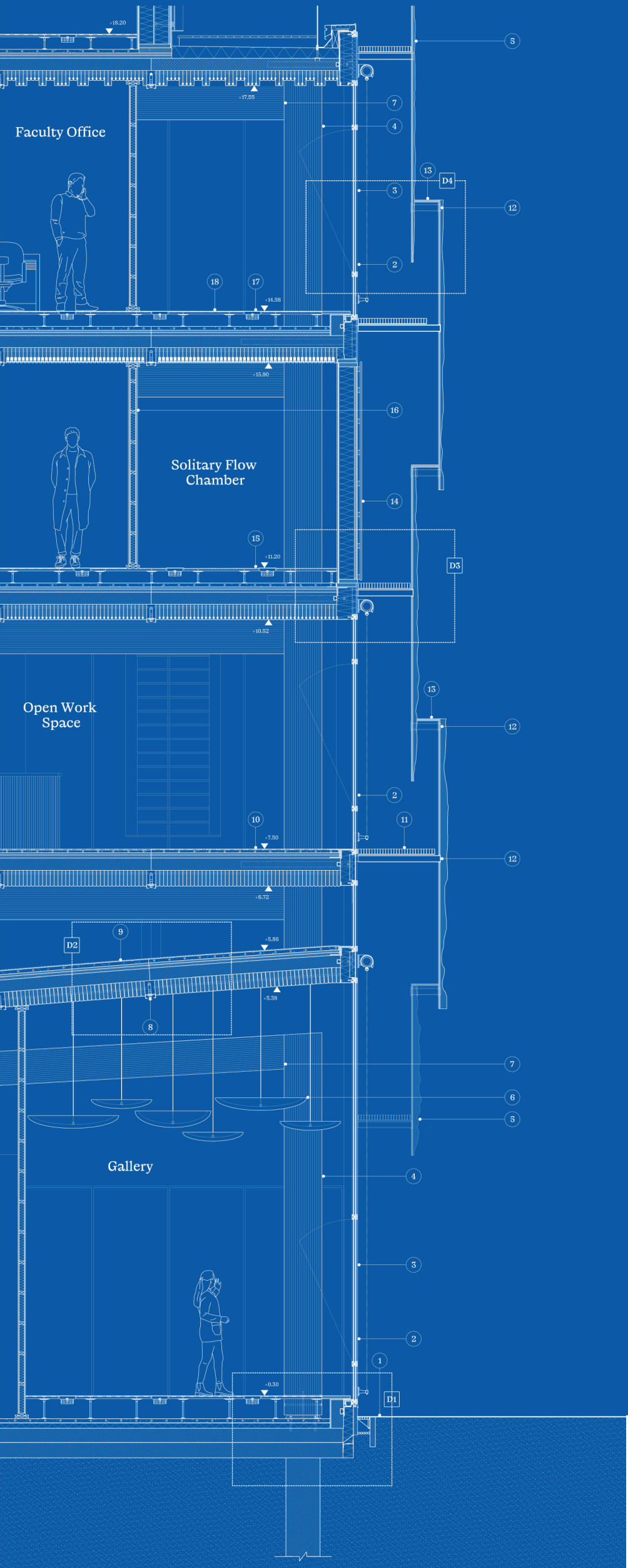
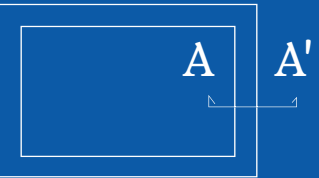

17. Curved DLT profile



Dowel Laminated Timber

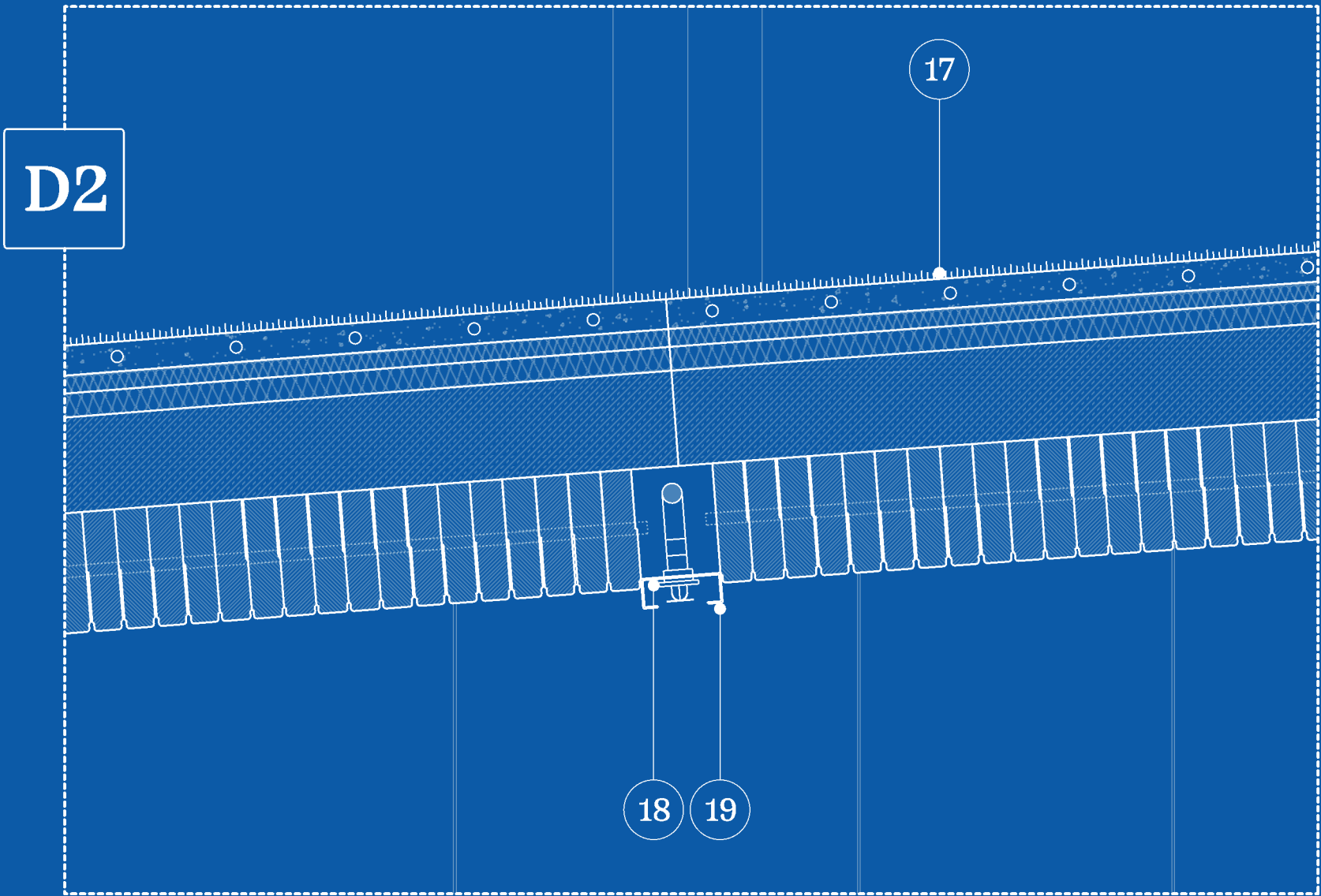
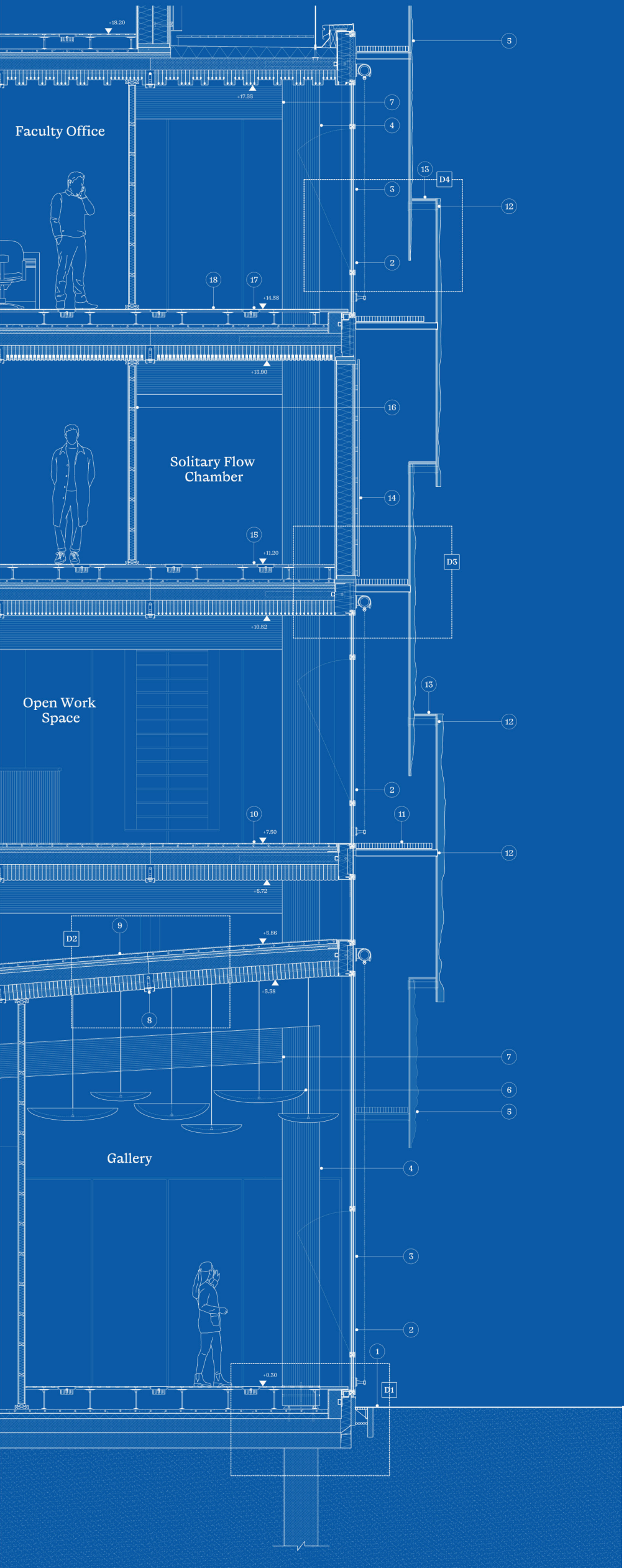
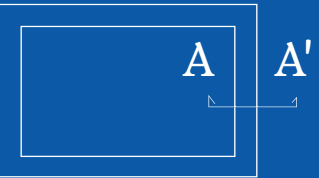

17. Curved DLT profile

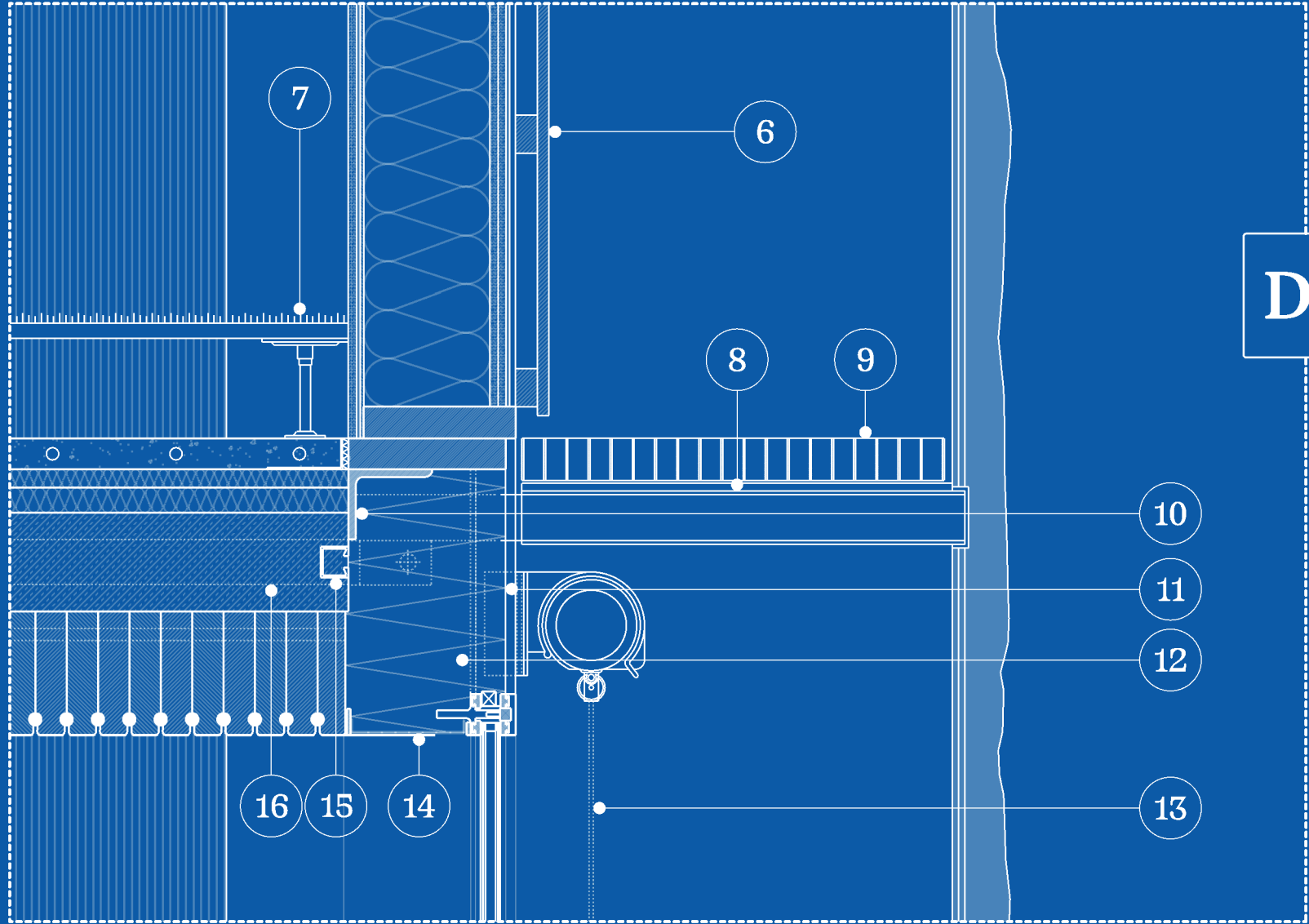

7. Acoustic fileted square profile w/ NRC = 0.5

0 0.5 m

Dowel Laminated Timber

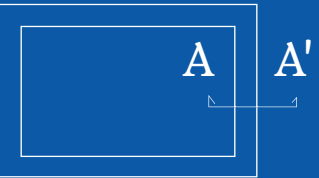

Softer profiles
and more grooved



Soft profile
and less grooved

D2

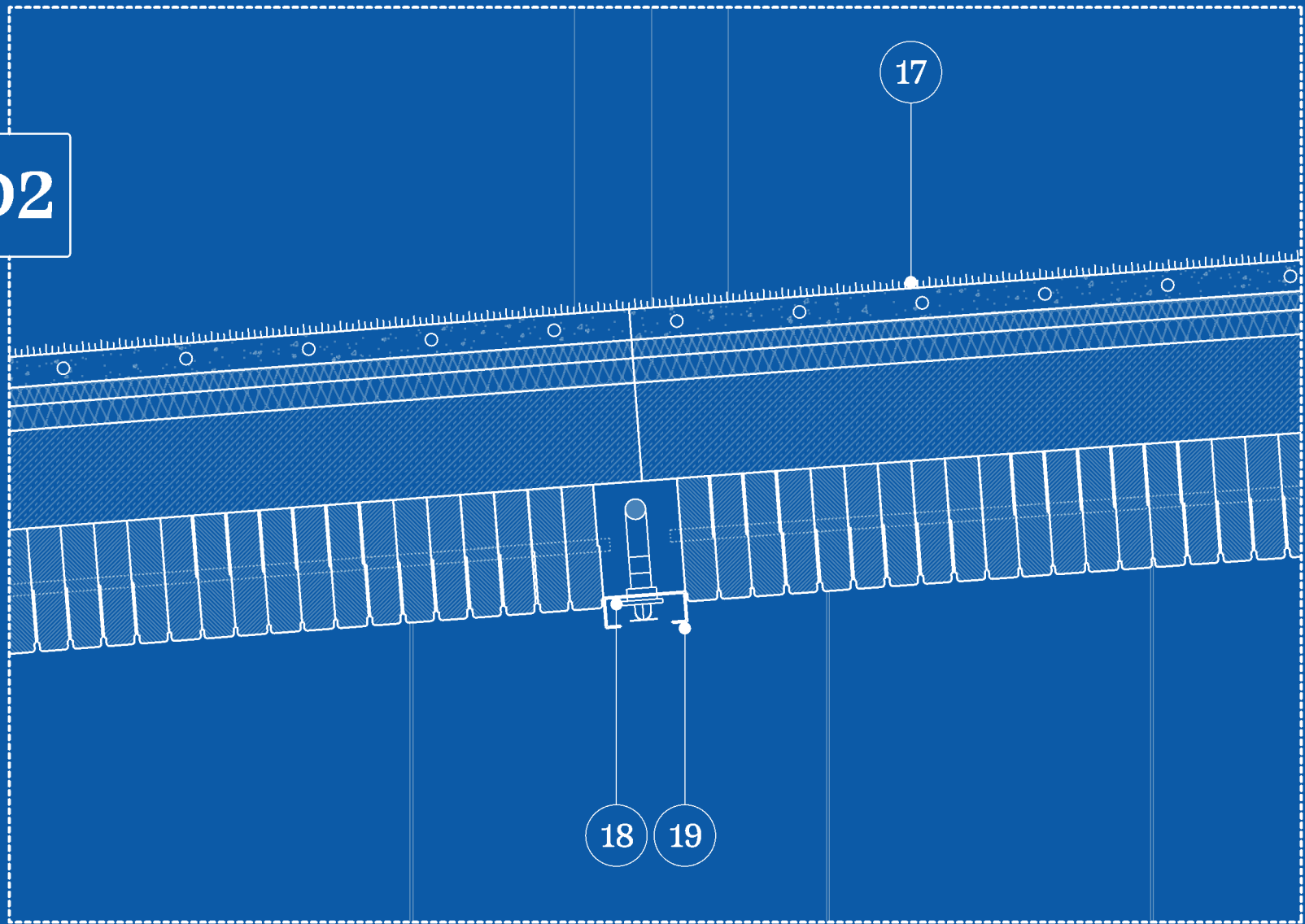

17. Curved DLT profile

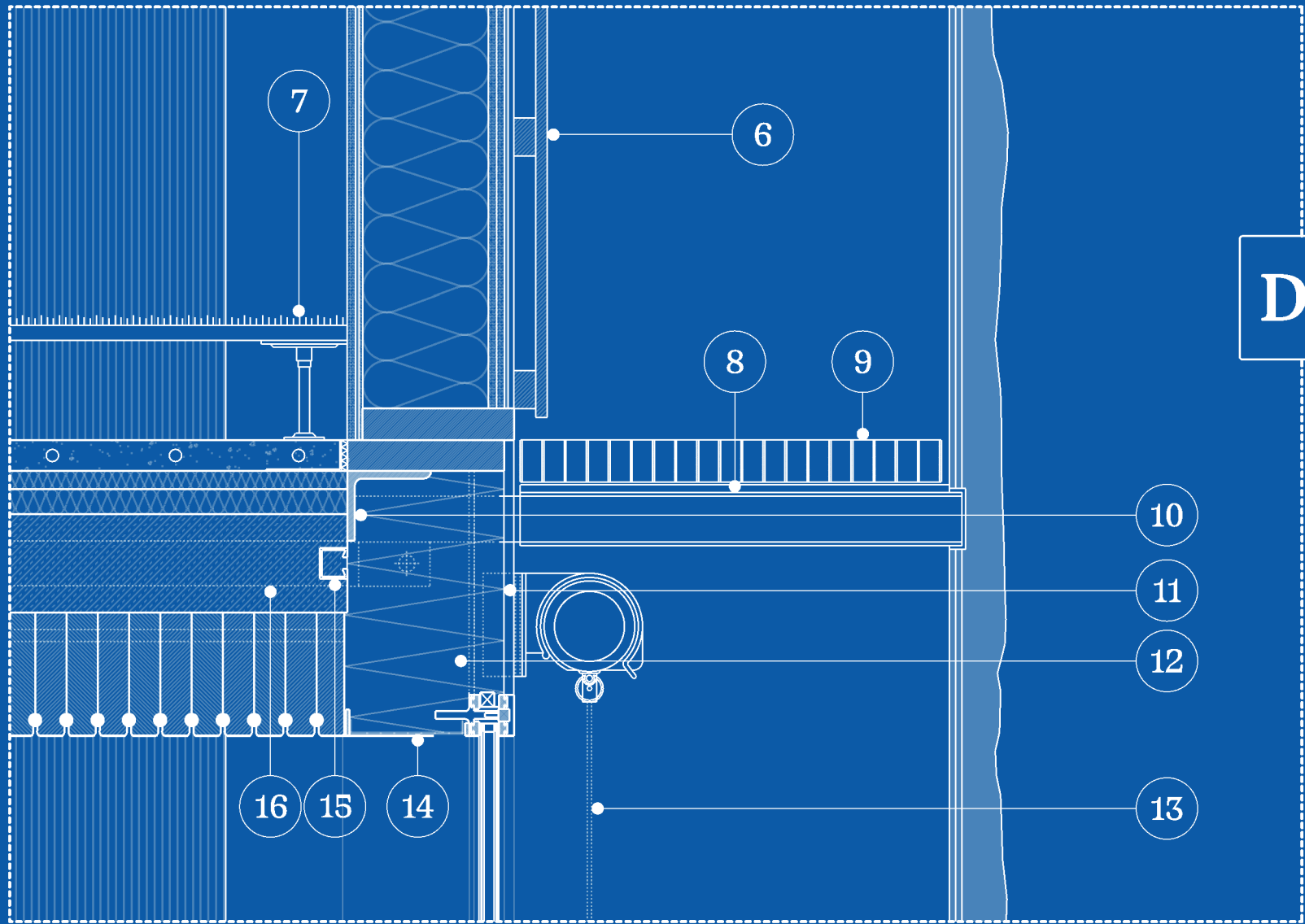

7. Acoustic fileted square profile w/ NRC = 0.5

D3

0 0.5 m



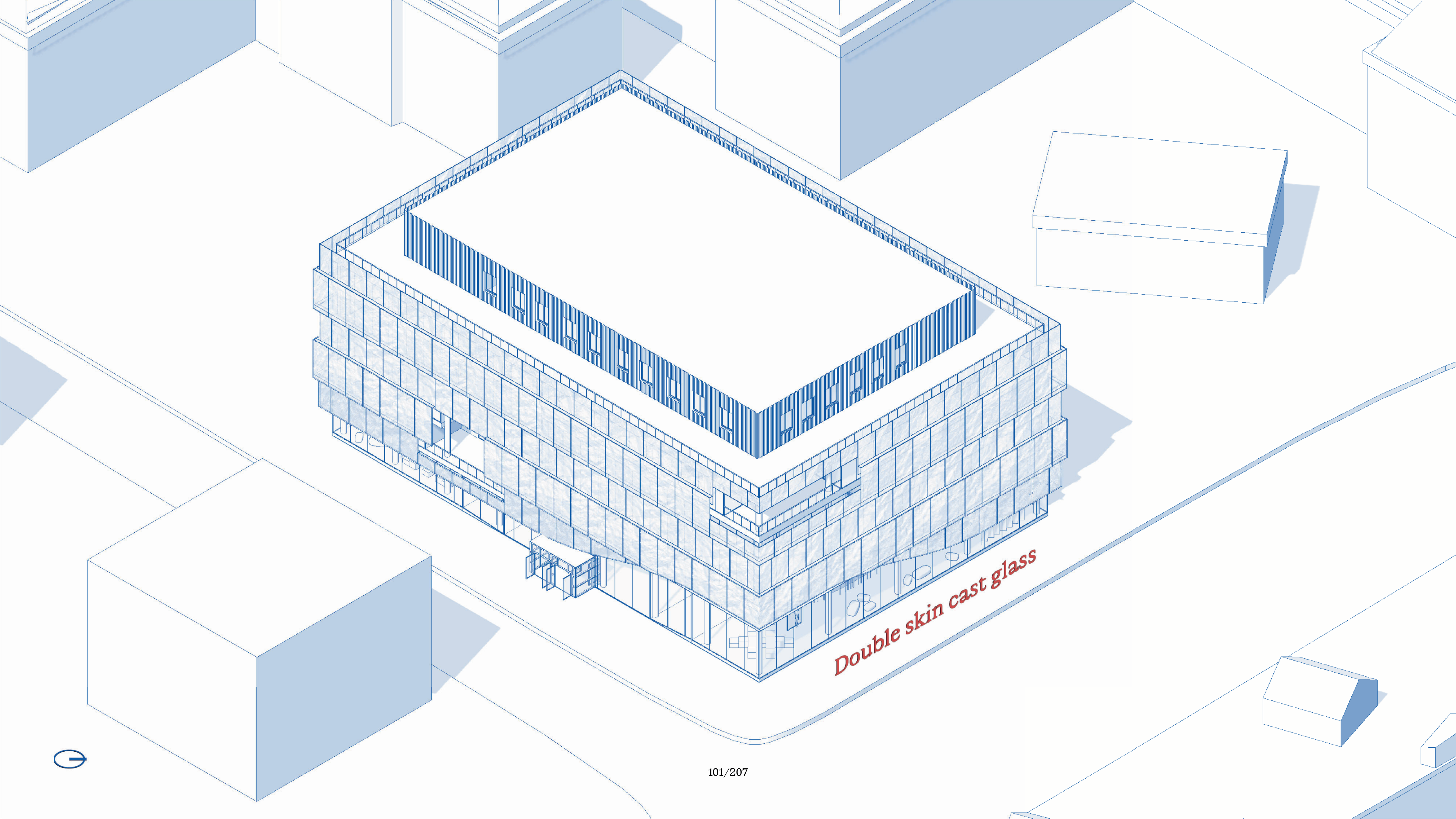

Double skin cast glass



Cast glass Double Skin Facade

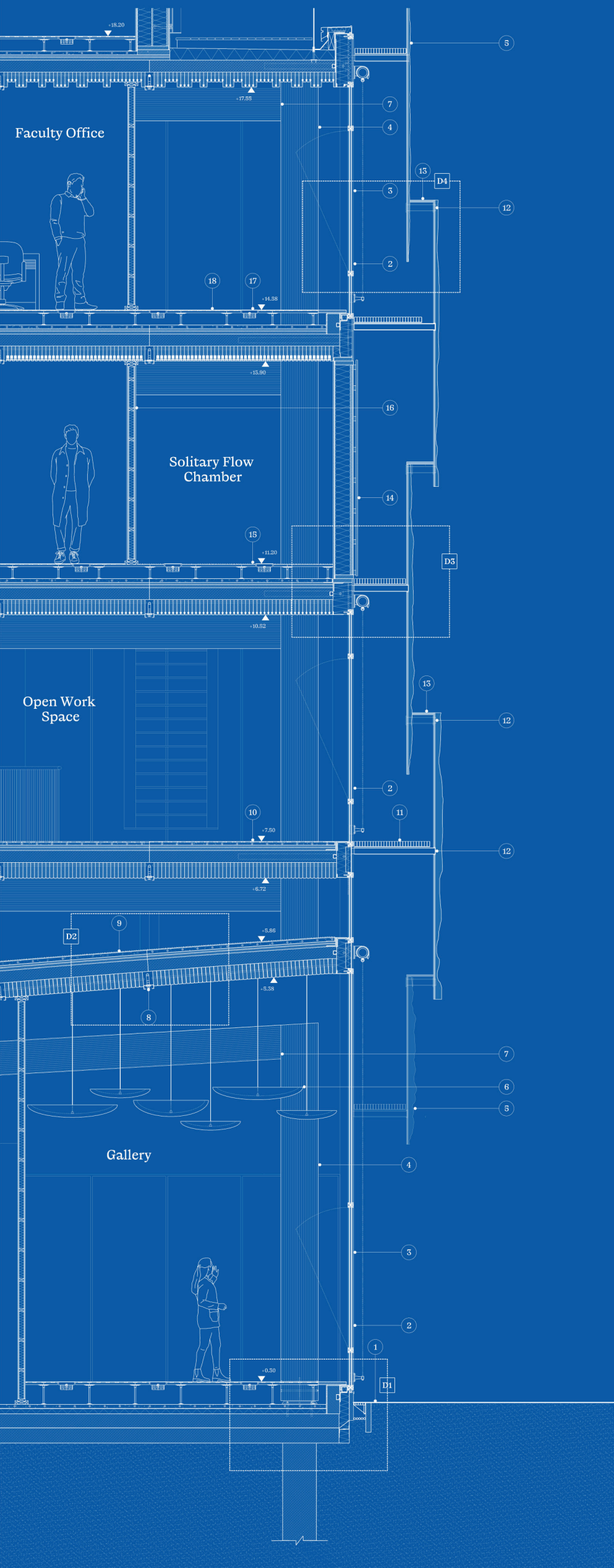

Cast glass Double Skin Facade

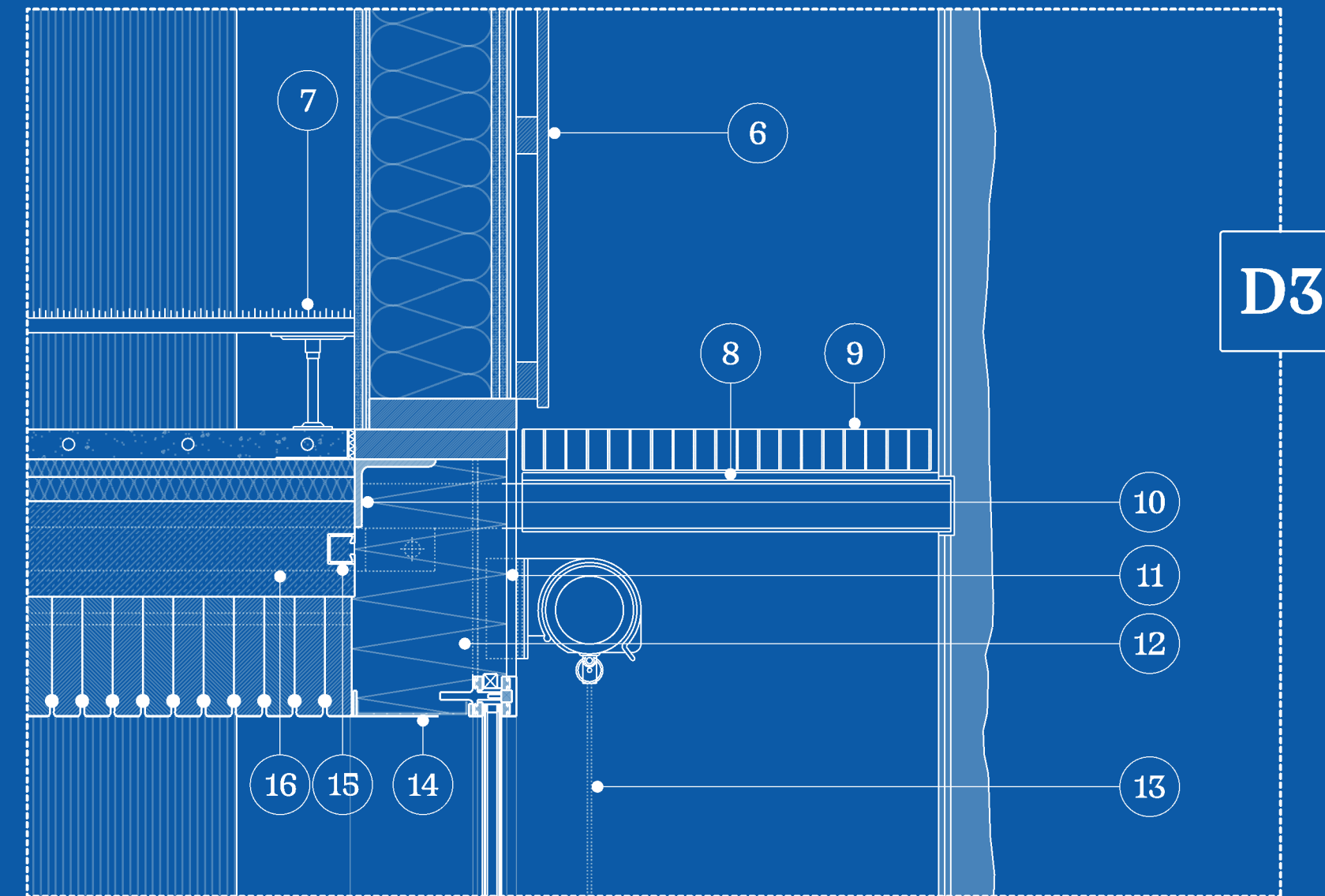
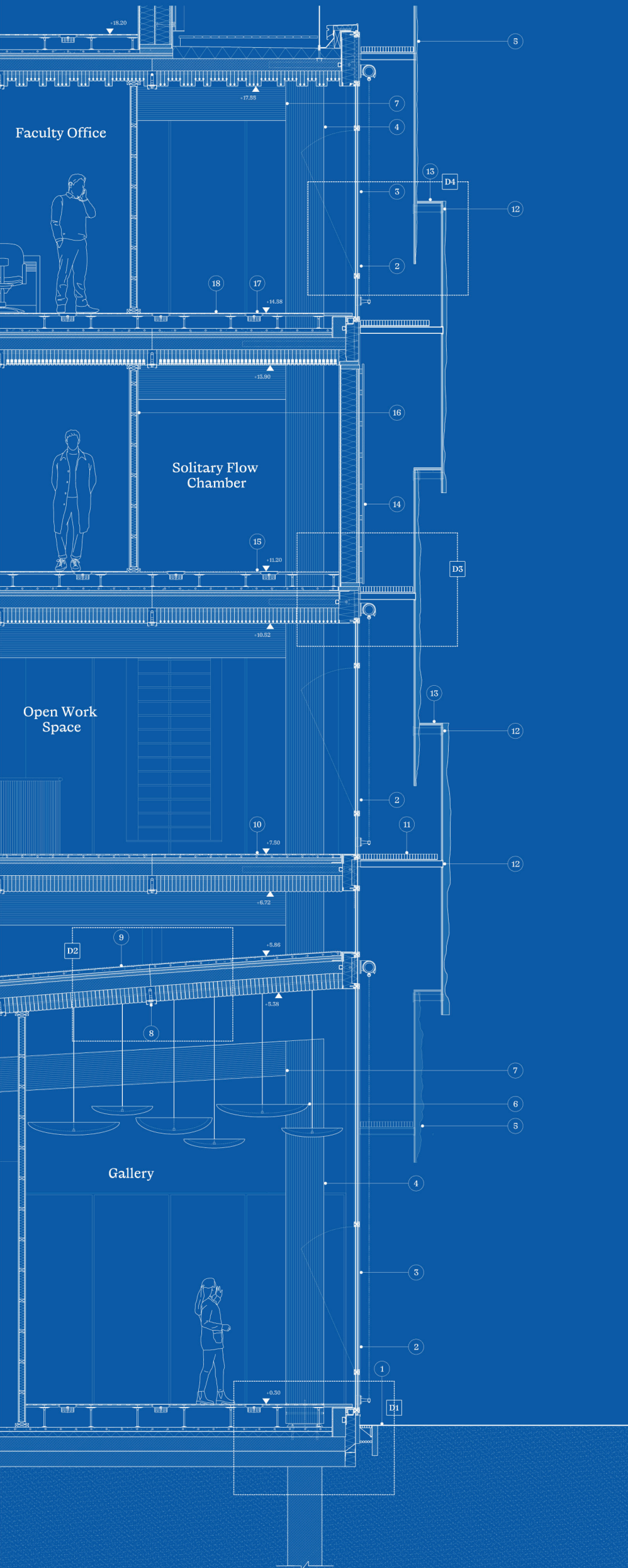
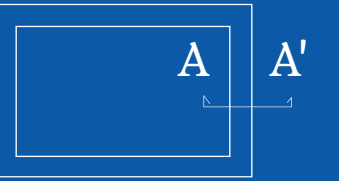

16. Casted glass to concrete slab connection



Cast glass Double Skin Facade

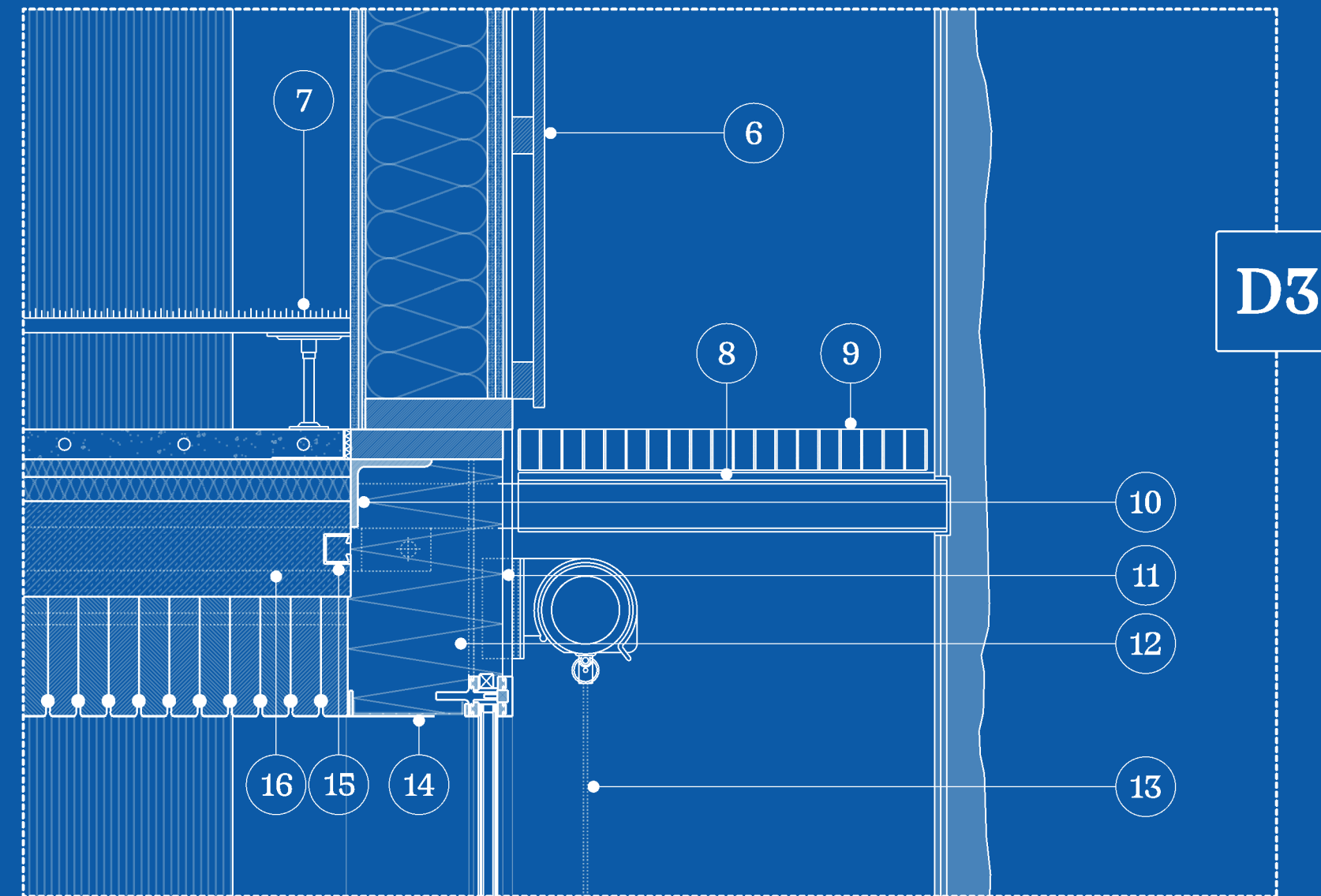
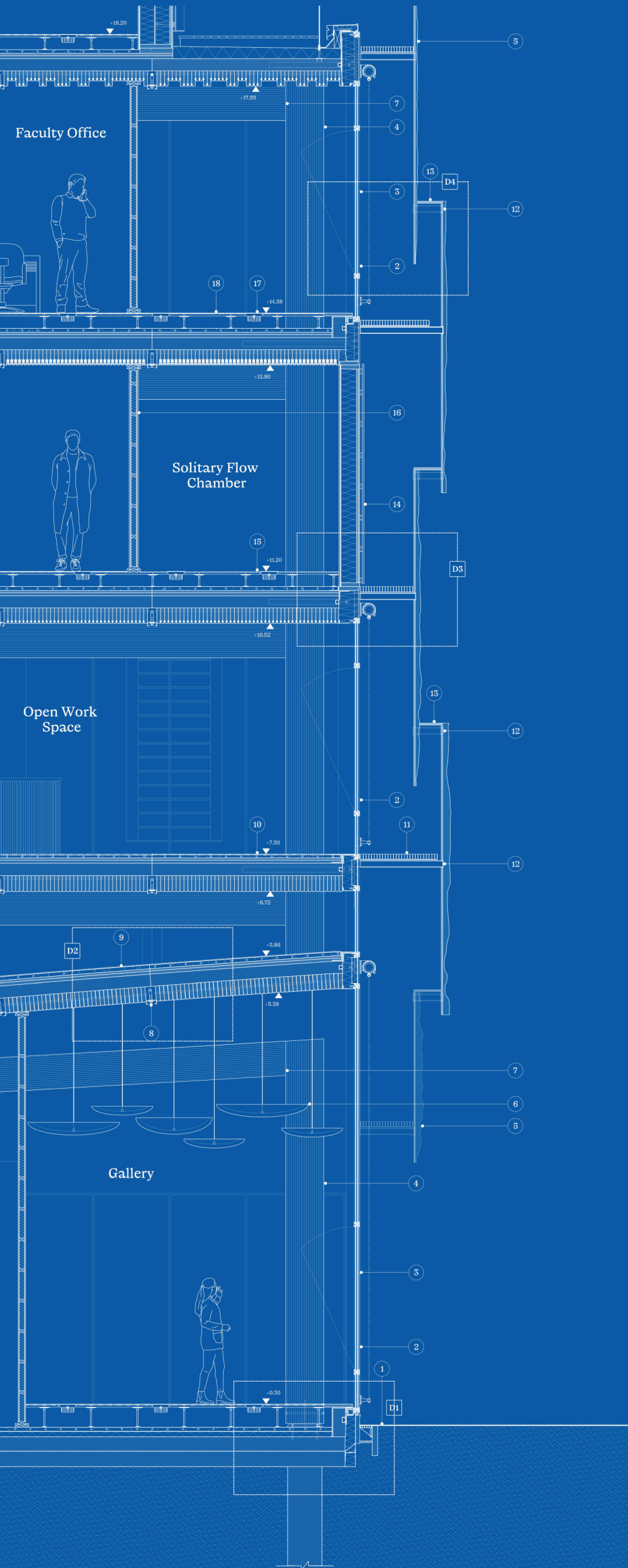
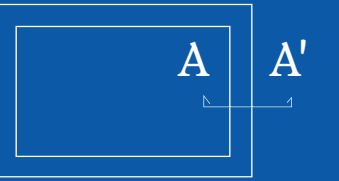

16. Casted glass to concrete slab connection

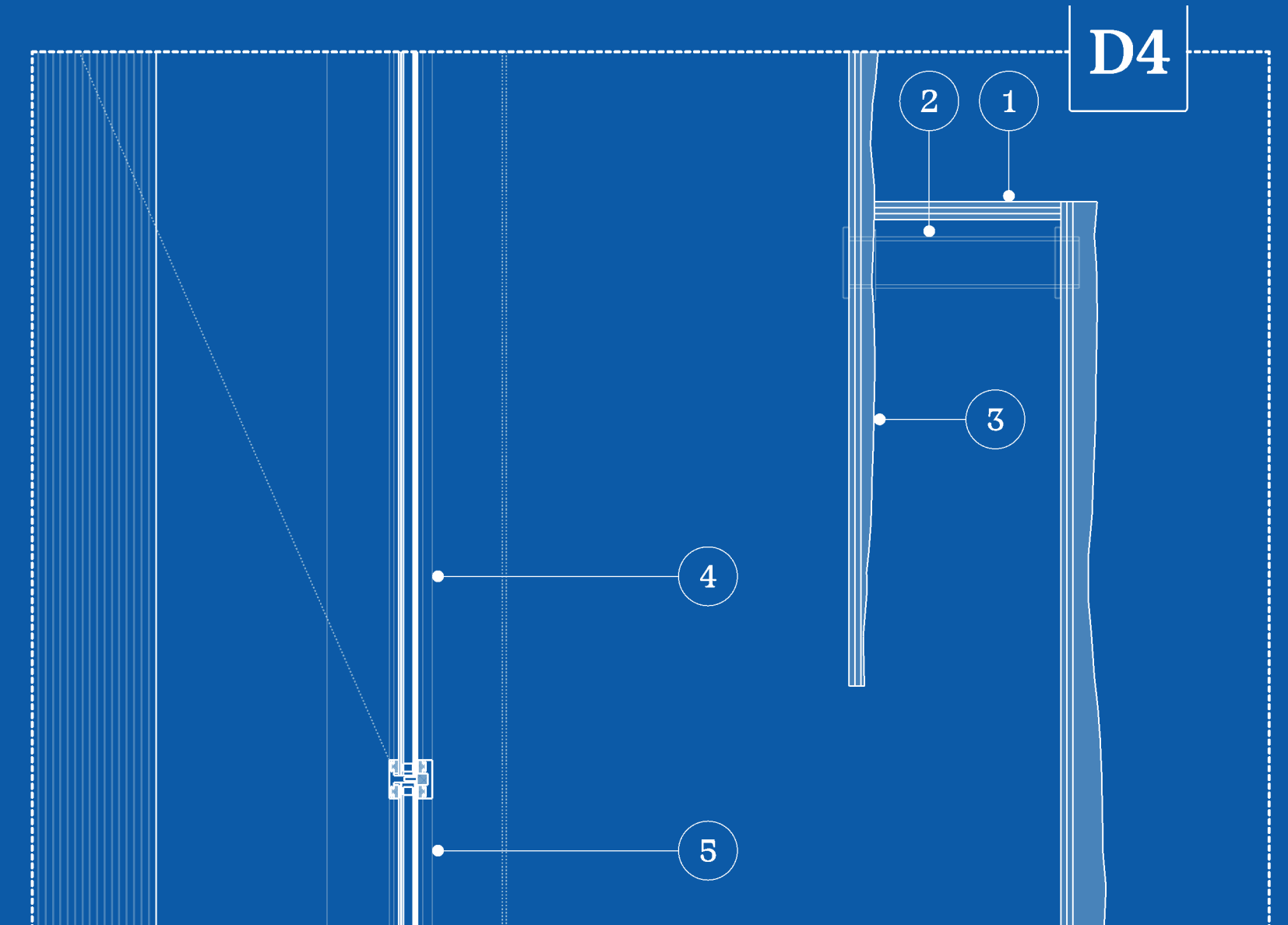

1. Horizontal glass element to close off facade for climate control

2. Mechanical connections panel to panel solid steel tube

3. Casted glass exterior facade
Casted glass size 3800x2000mm(t):20-65mm,
laminated glass size: 3800x2000mm (t)10x2mm



Cast glass Double Skin Facade

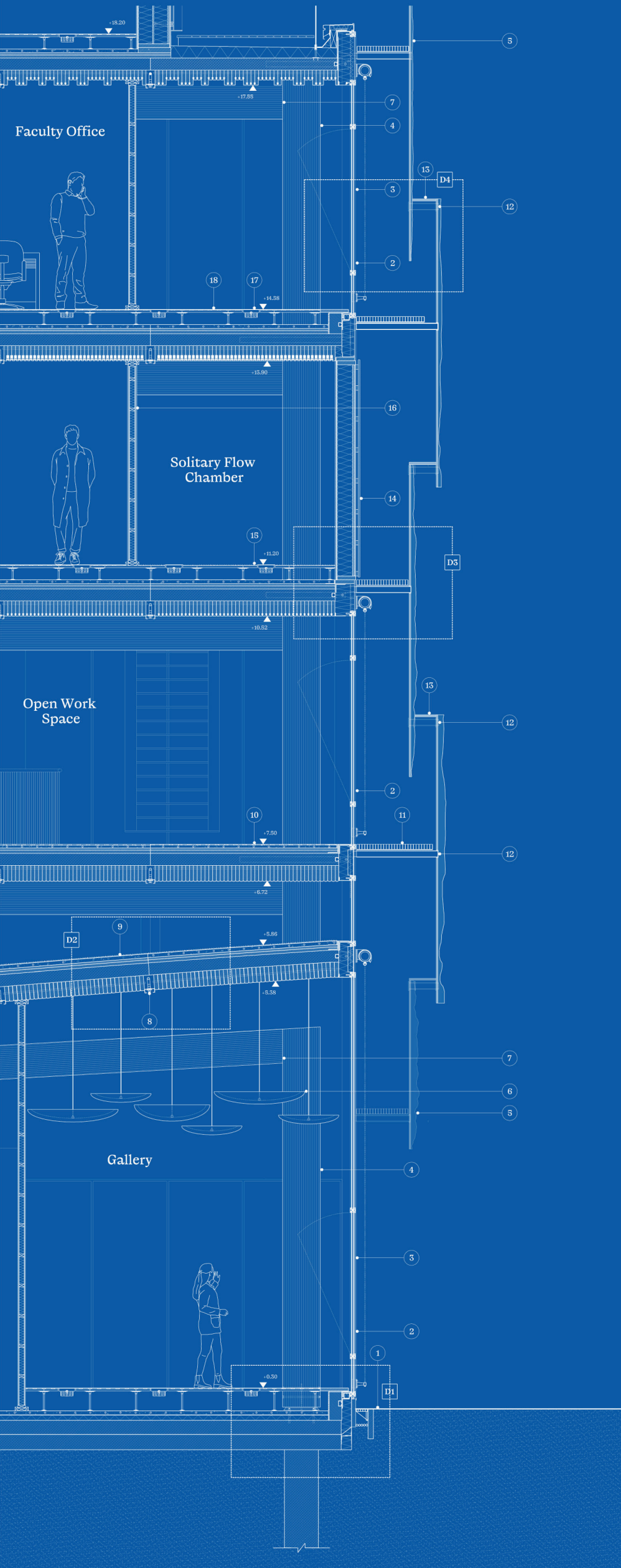
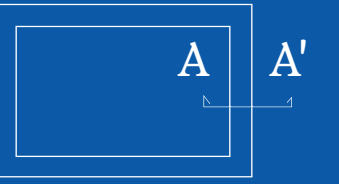

16. Casted glass to concrete slab connection



1. Horizontal glass element to close off facade for climate control

2. Mechanical connections panel to panel solid steel tube

3. Casted glass exterior facade
Casted glass size 3800x2000mm(t):20-65mm,
laminated glass size: 3800x2000mm (t)10x2mm



Cast glass Double Skin Facade

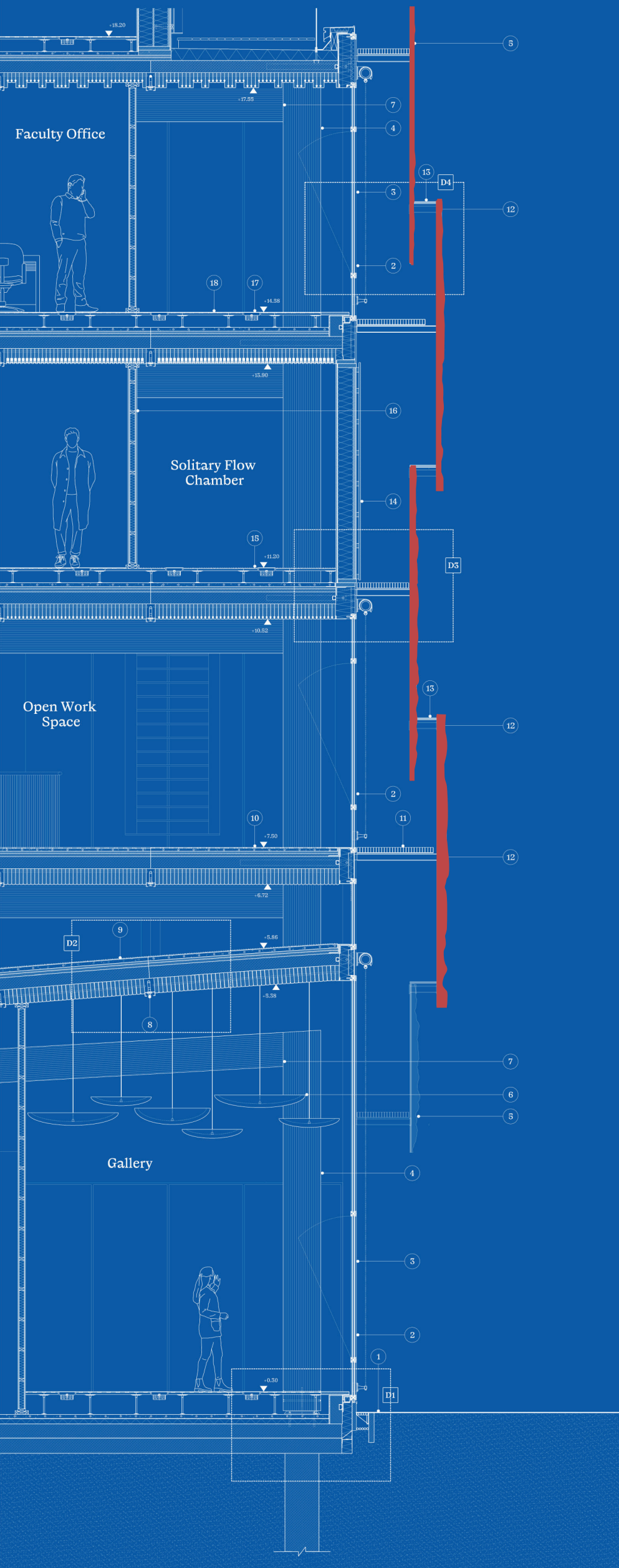
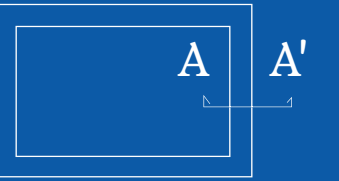

16. Casted glass to concrete slab connection



1. Horizontal glass element to close off facade for climate control

2. Mechanical connections panel to panel solid steel tube

3. Casted glass exterior facade
Casted glass size 3800x2000mm(t):20-65mm,
laminated glass size: 3800x2000mm (t)10x2mm

Cast glass Double Skin Facade

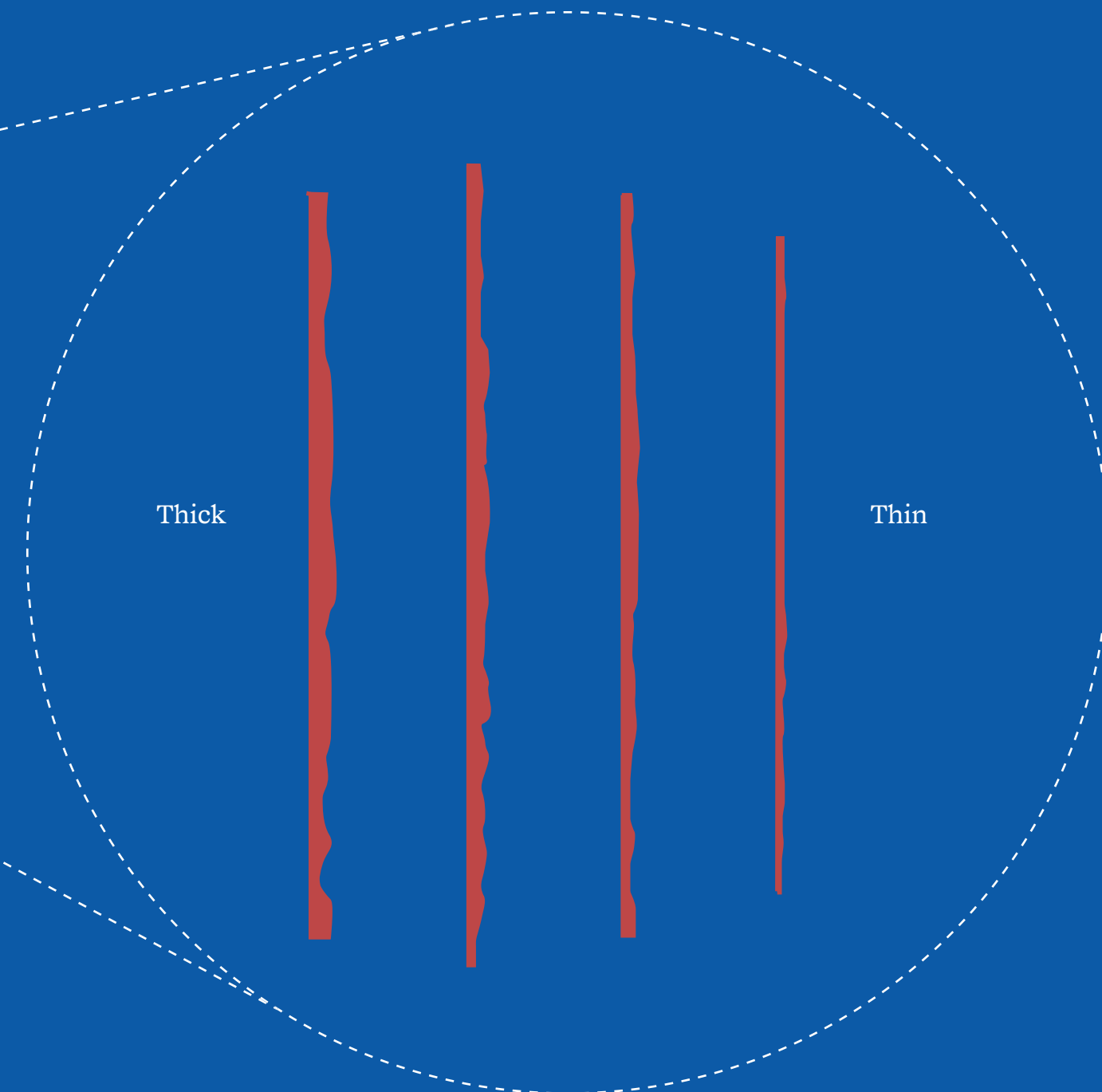
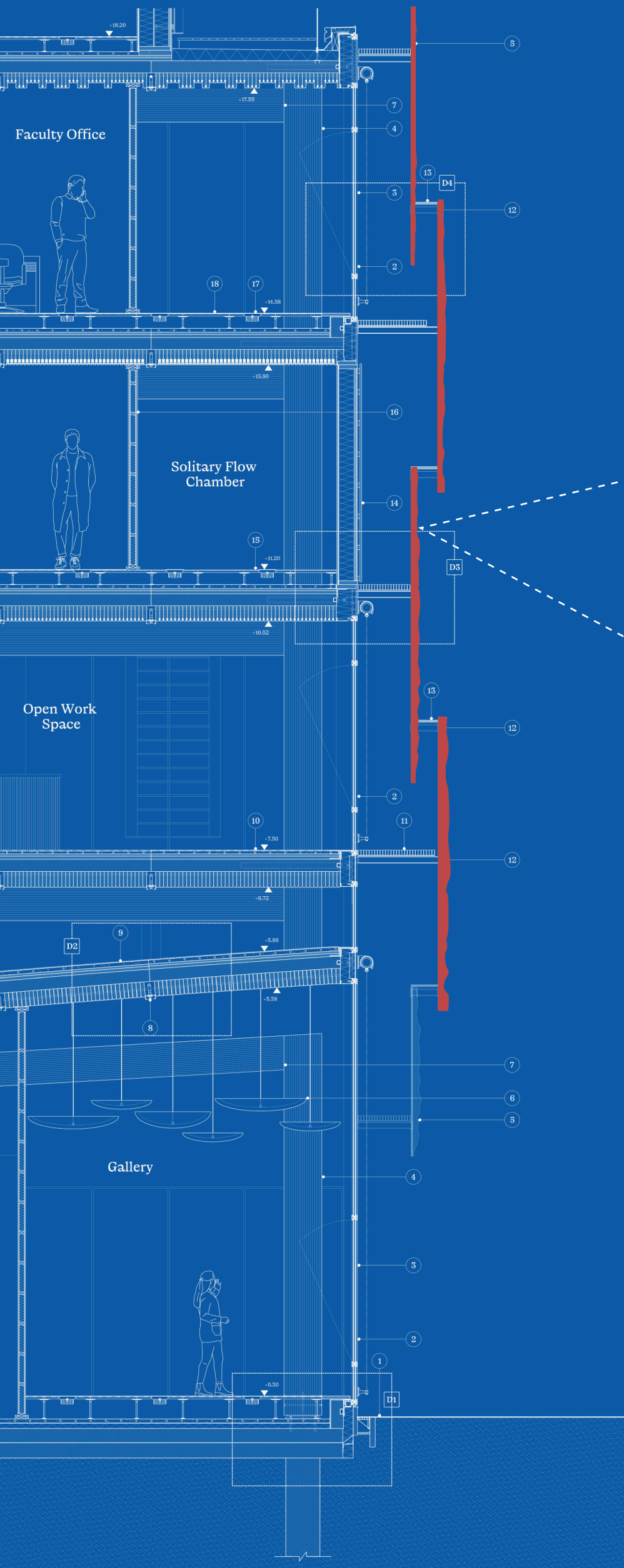
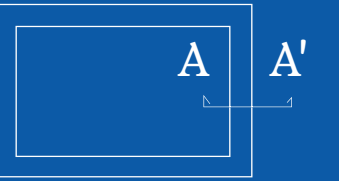

Cast glass Double Skin Facade

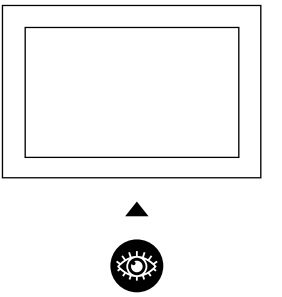

Translucent
↑
Semi-opaque

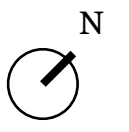
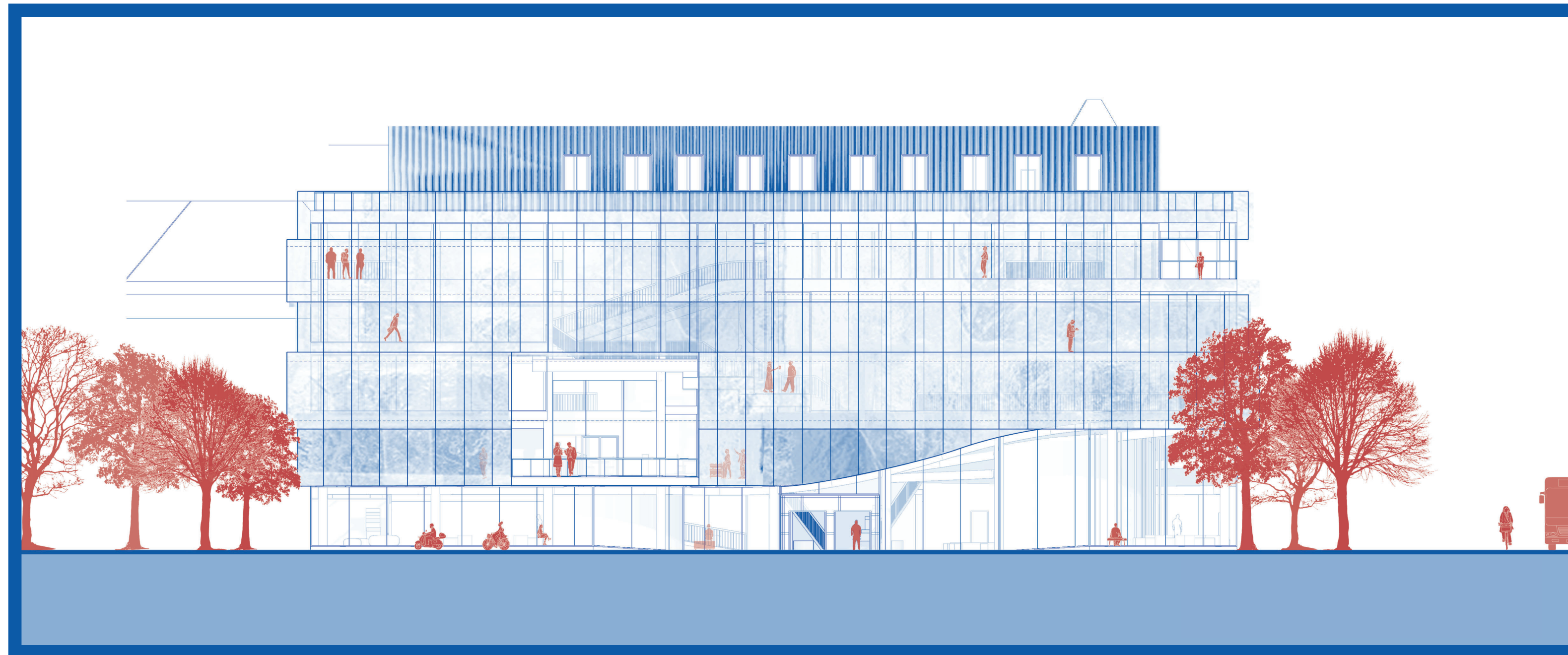

0 10 m

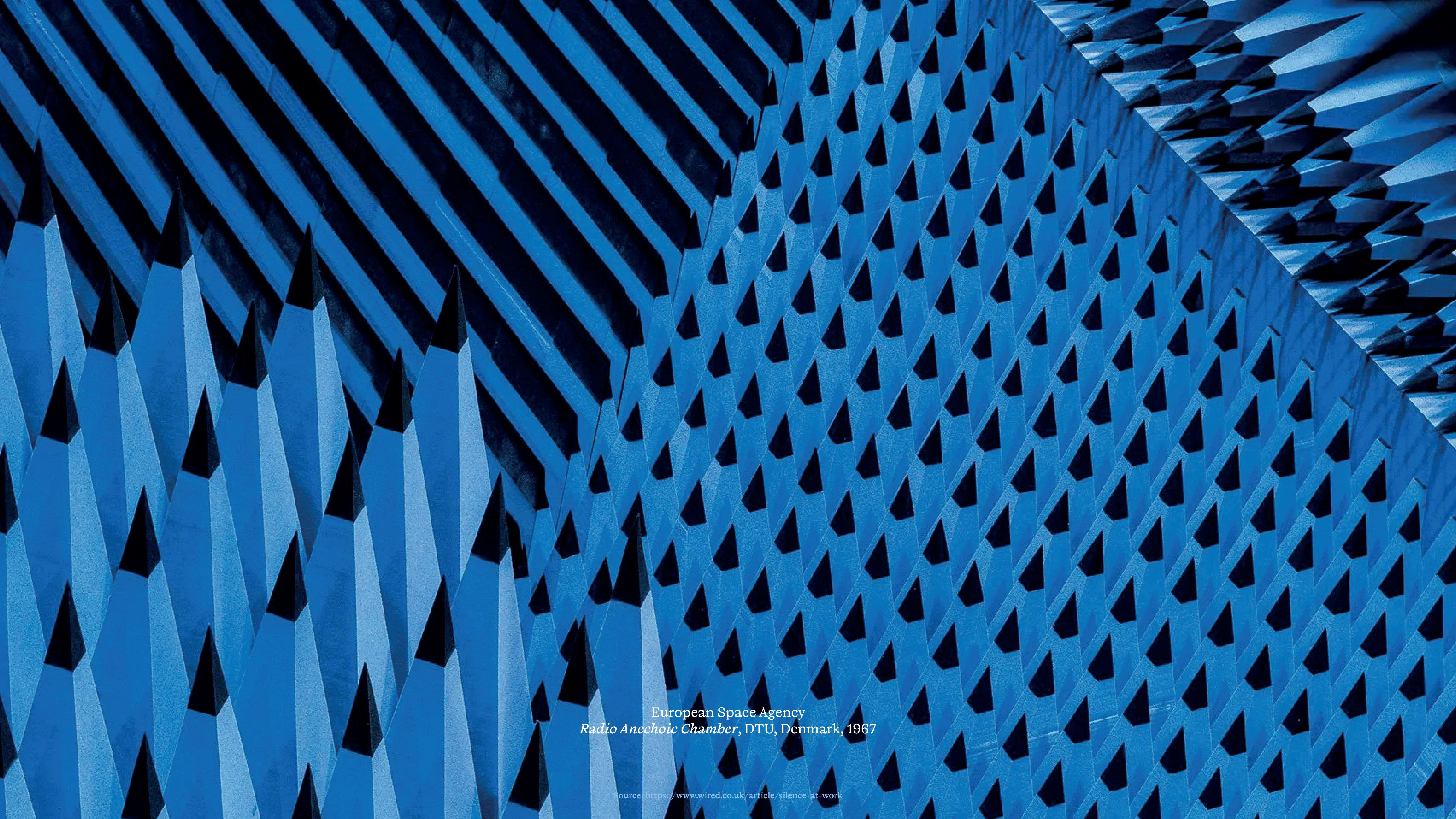

European Space Agency
Radio Anechoic Chamber, DTU, Denmark, 1967

4.

Spaces for Flow

4.

Spaces for Flow

During *flow*, the brain is functioning at its fullest capacity and is wholeheartedly dedicated to the task at hand. In this space, the mind is acute. It's not daydreaming or loitering around in its shallower registers, accessing superficial thoughts, gossipy insights, and banal fantasies. No, here, in this space, the brain is "total" and "perfect."

The Faraday Cage



Lawrence Bragg
Faraday Cage, The Royal Institution, London, 1960

<<The ability to perform deep work is becoming increasingly rare at exactly the same time it is becoming increasingly valuable in our economy. As a consequence, the few who cultivate this skill, and then make it the core of their working life, will thrive.>>

Cal Newport
Deep Work, 2015

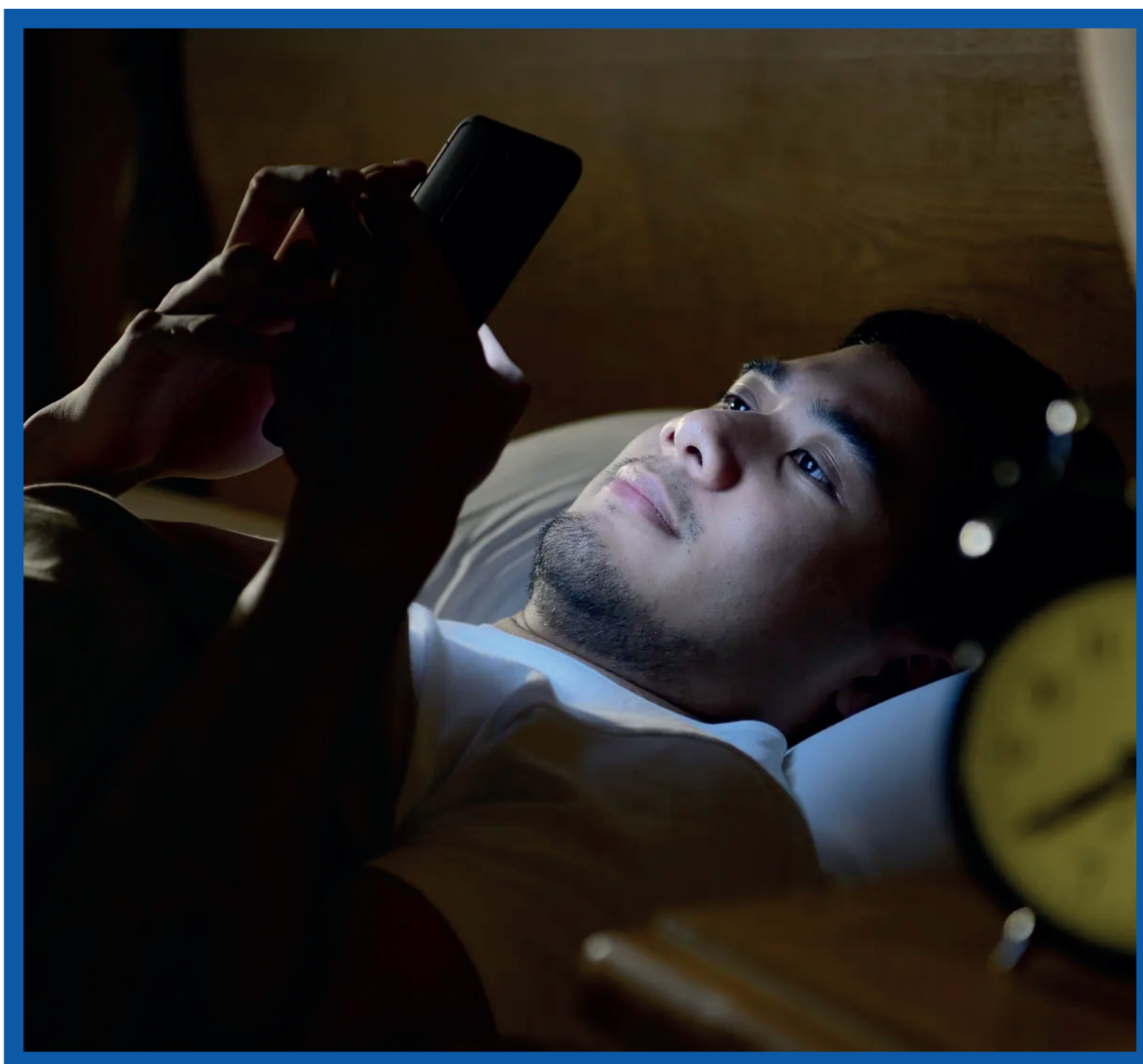



«Within the first 15 minutes of waking up, 4 out of 5 smartphone owners are checking their phones.»



Distractions

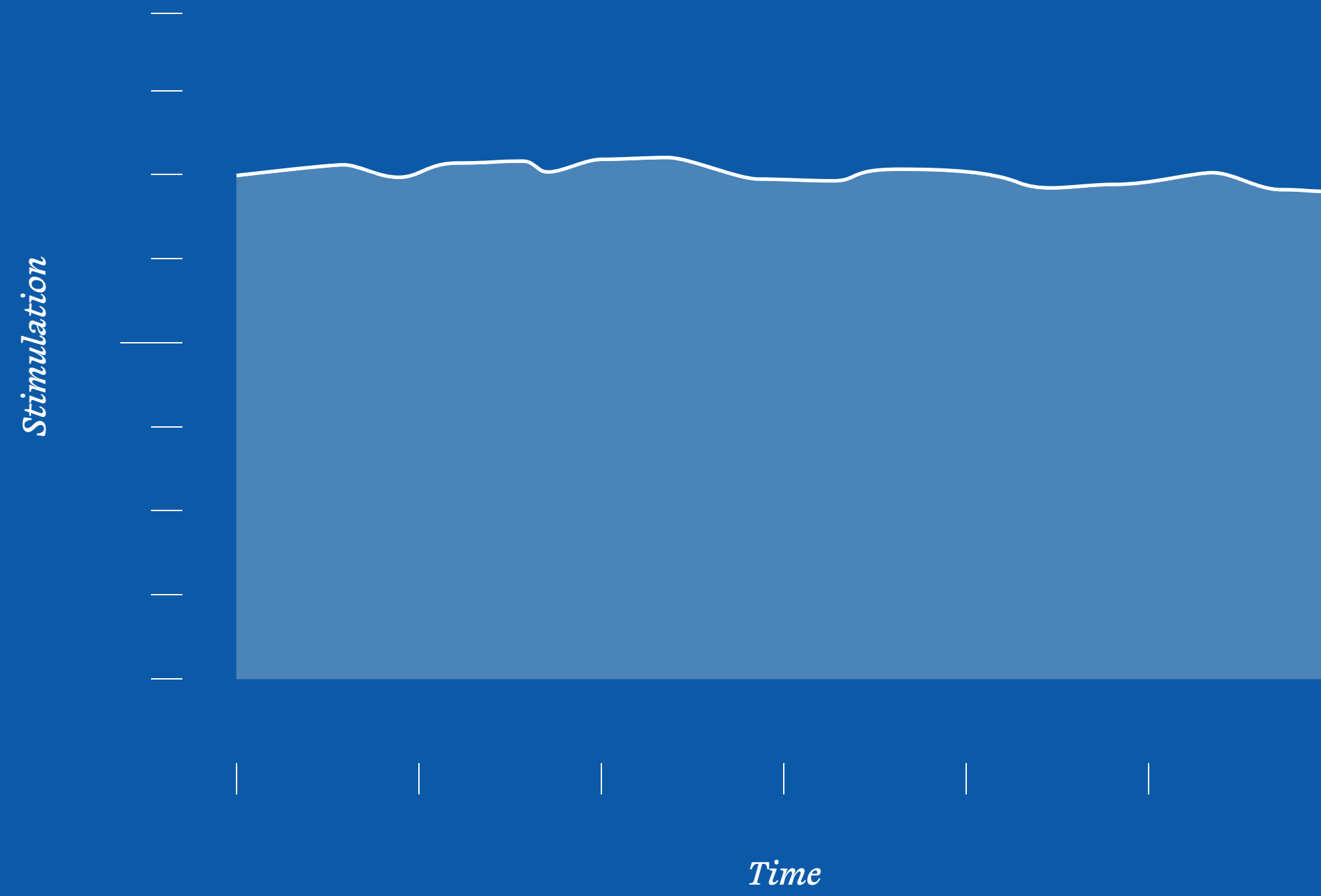

Distractions

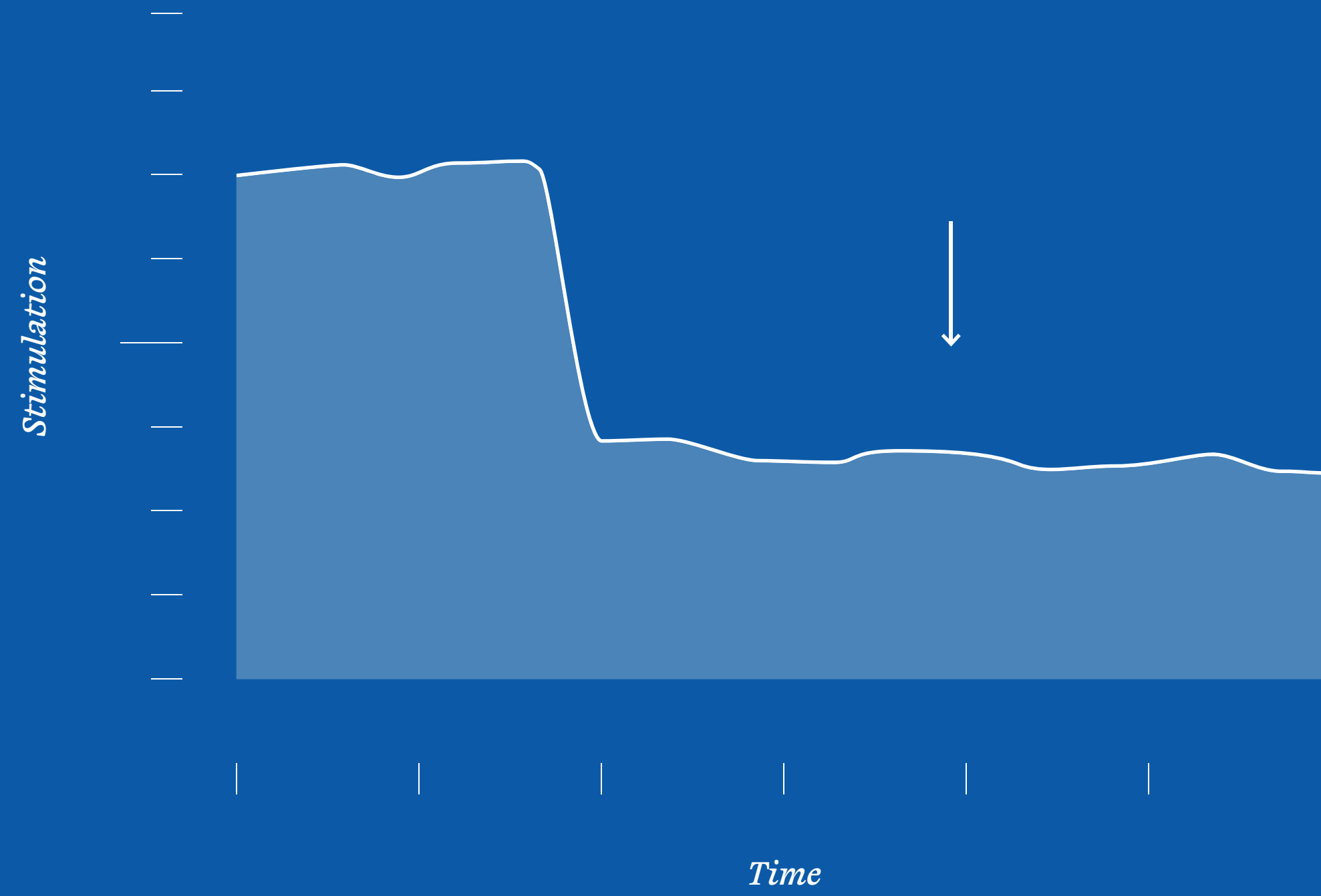

Solitary Flow Chamber

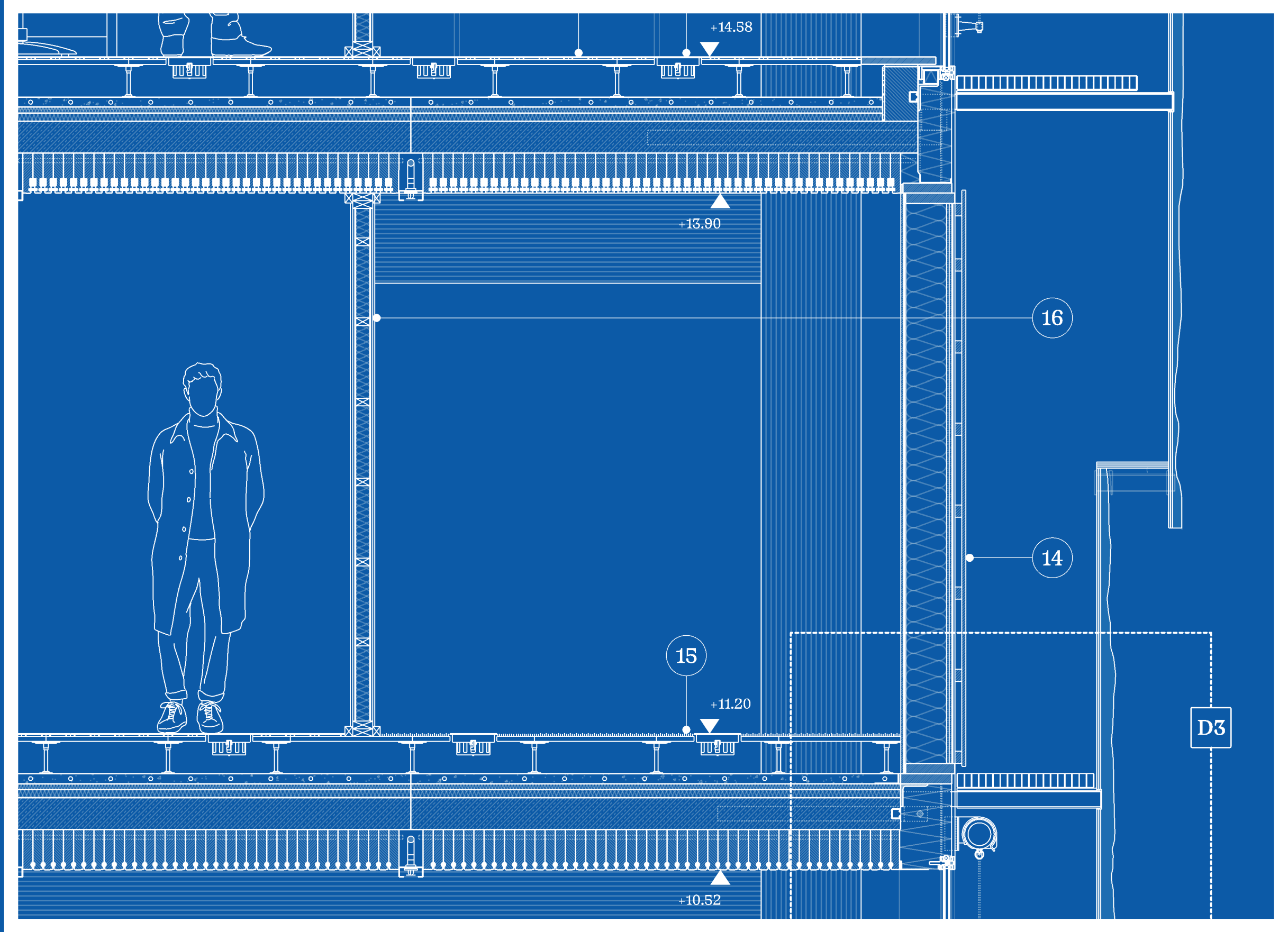
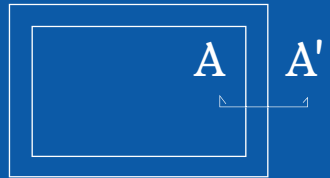

Solitary Flow Chamber

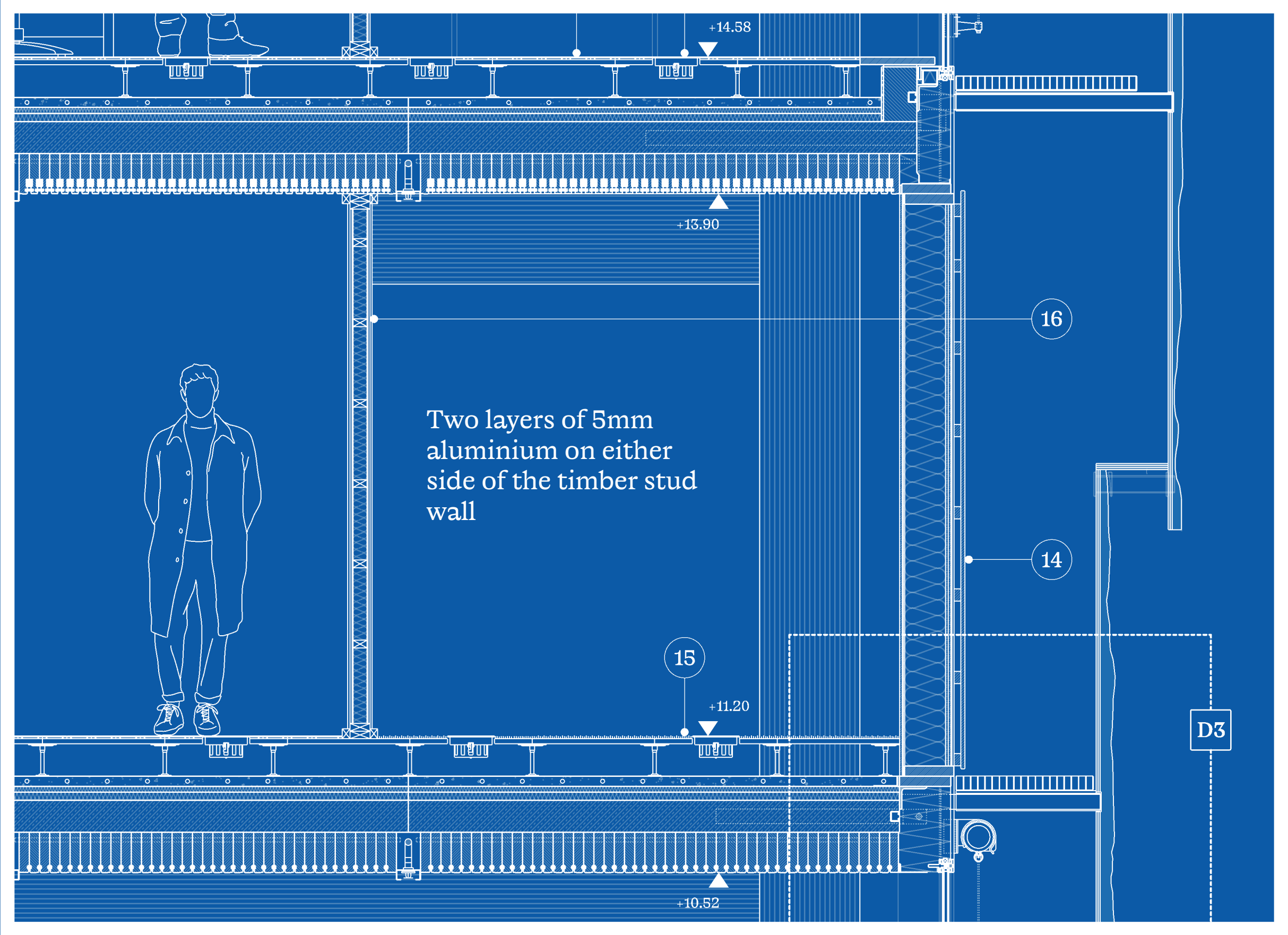
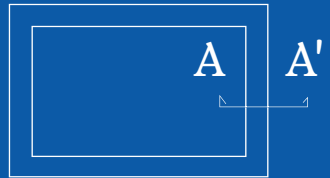

Solitary Flow Chamber



The Living Lab

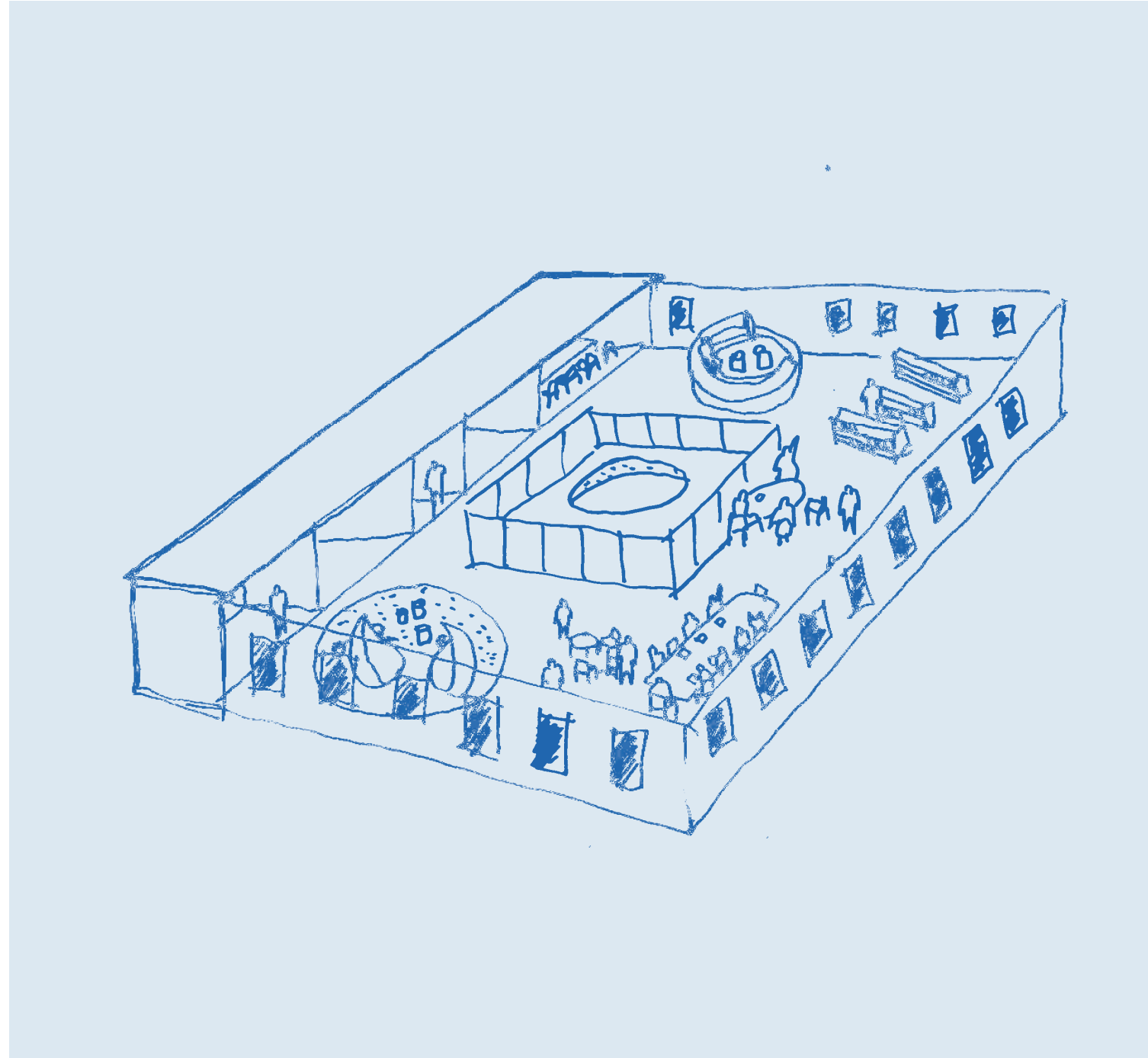

The Living Lab



The Living Lab



Microphones

The Living Lab



Microphones

Occupancy sensors

The Living Lab



Microphones

Occupancy sensors

Embedded audio systems

The Living Lab



Smart thermal system

The Living Lab



Pride

Smart thermal system

The Living Lab

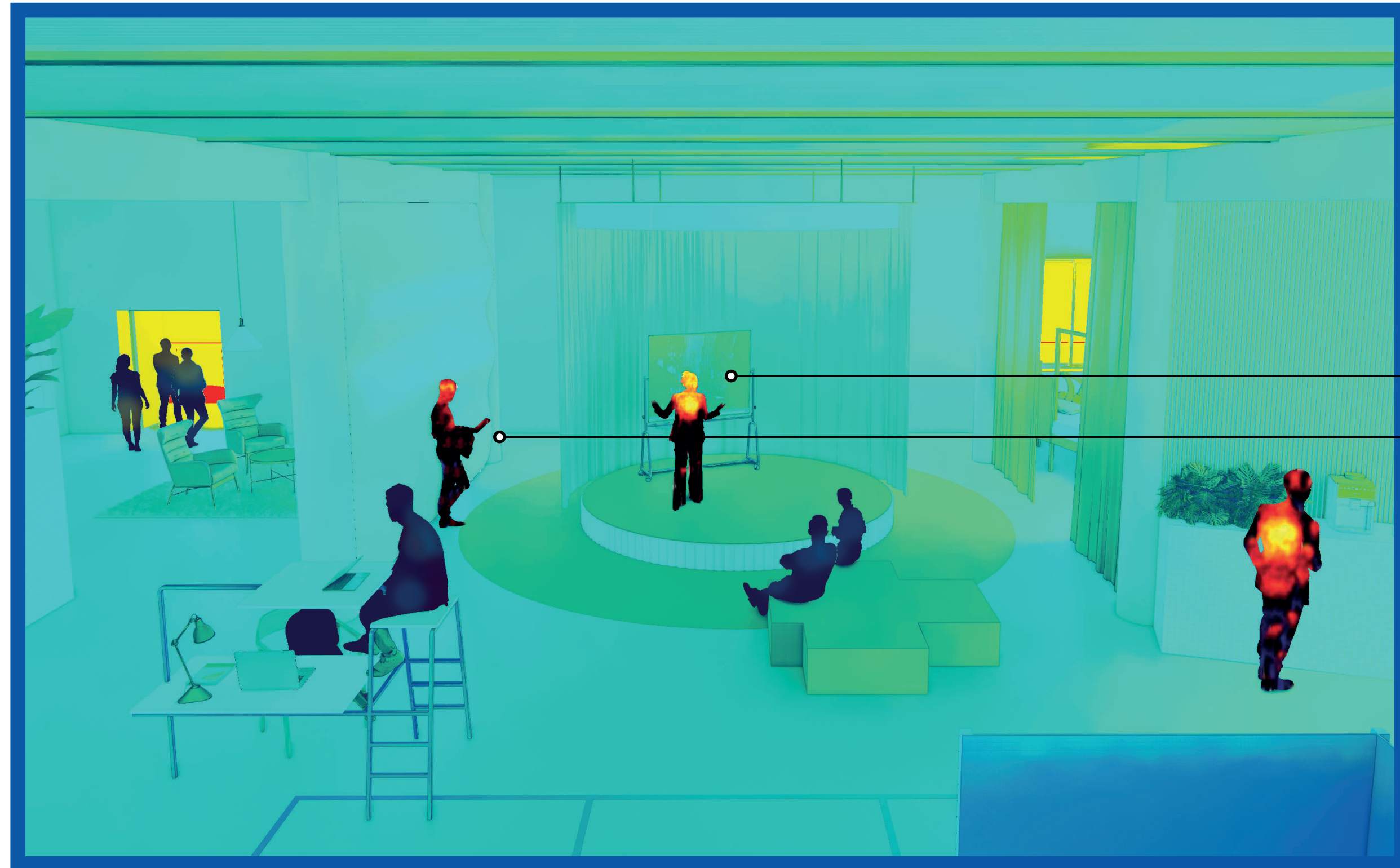

Pride

Surprise

Smart thermal system

The Living Lab



Pride

Surprise

Anxiety

Smart thermal system

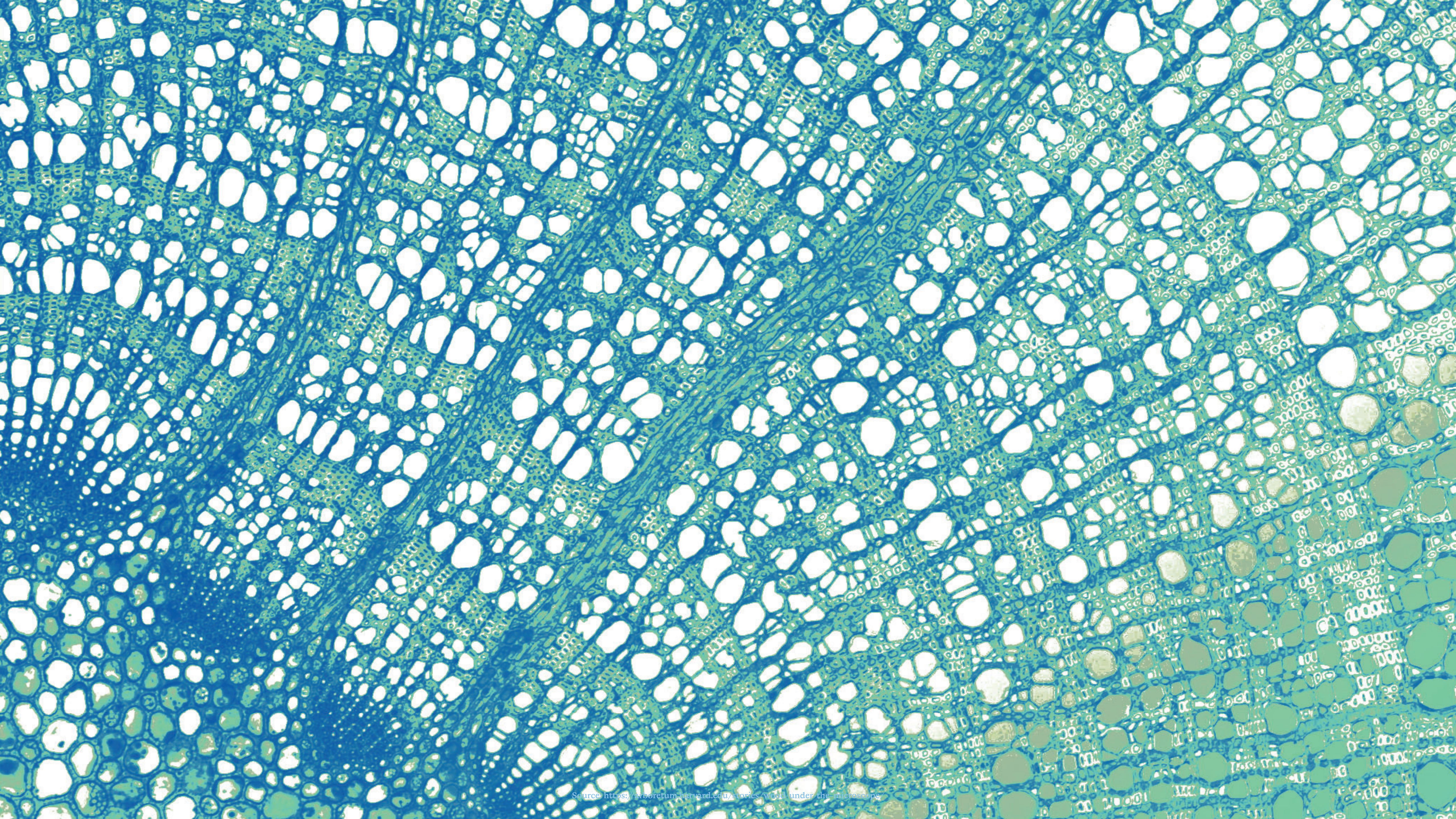

5.

Evidence Based Design

Part 5 discusses why and how robust evidence was judiciously utilised in making critical design decisions in the project.

Quiz!



***A bat and ball cost \$1.10
The bat costs one dollar more than the ball.
How much does the ball cost?***

***A bat and ball cost \$1.10
The bat costs one dollar more than the ball.
How much does the ball cost?***

A. 20¢

B. 10¢

C. 1¢

D. None of them

*A bat and ball cost \$1.10
The bat costs one dollar more than the ball.
How much does the ball cost?*

A. 20¢

B. 10¢

C. 1¢

D. None of them

***A bat and ball cost \$1.10
The bat costs one dollar more than the ball.
How much does the ball cost?***



$$x + 1 + x = 1.10$$

$$2x + 1 = 1.10$$

$$2x = 1.10 - 1$$

$$2x = 0.1$$

$$x = 0.05$$

***A bat and ball cost \$1.10
The bat costs one dollar more than the ball.
How much does the ball cost?***

$$\begin{aligned}x + 1 + x &= 1.10 \\2x + 1 &= 1.10 \\2x &= 1.10 - 1 \\2x &= 0.1 \\x &= 0.05\end{aligned}$$

The ball costs ¢5.

<<Indeed 95% of our decisions origin from the unconscious mind and only 5% is from a conscious one.>>

Gerard Zaltman

How customers think: essential insights into the minds of the market, 2003

Designing for Flow

Designing for Flow

Social Flow

Solitary Flow

Flow Type

Designing for Flow



Designing for Flow

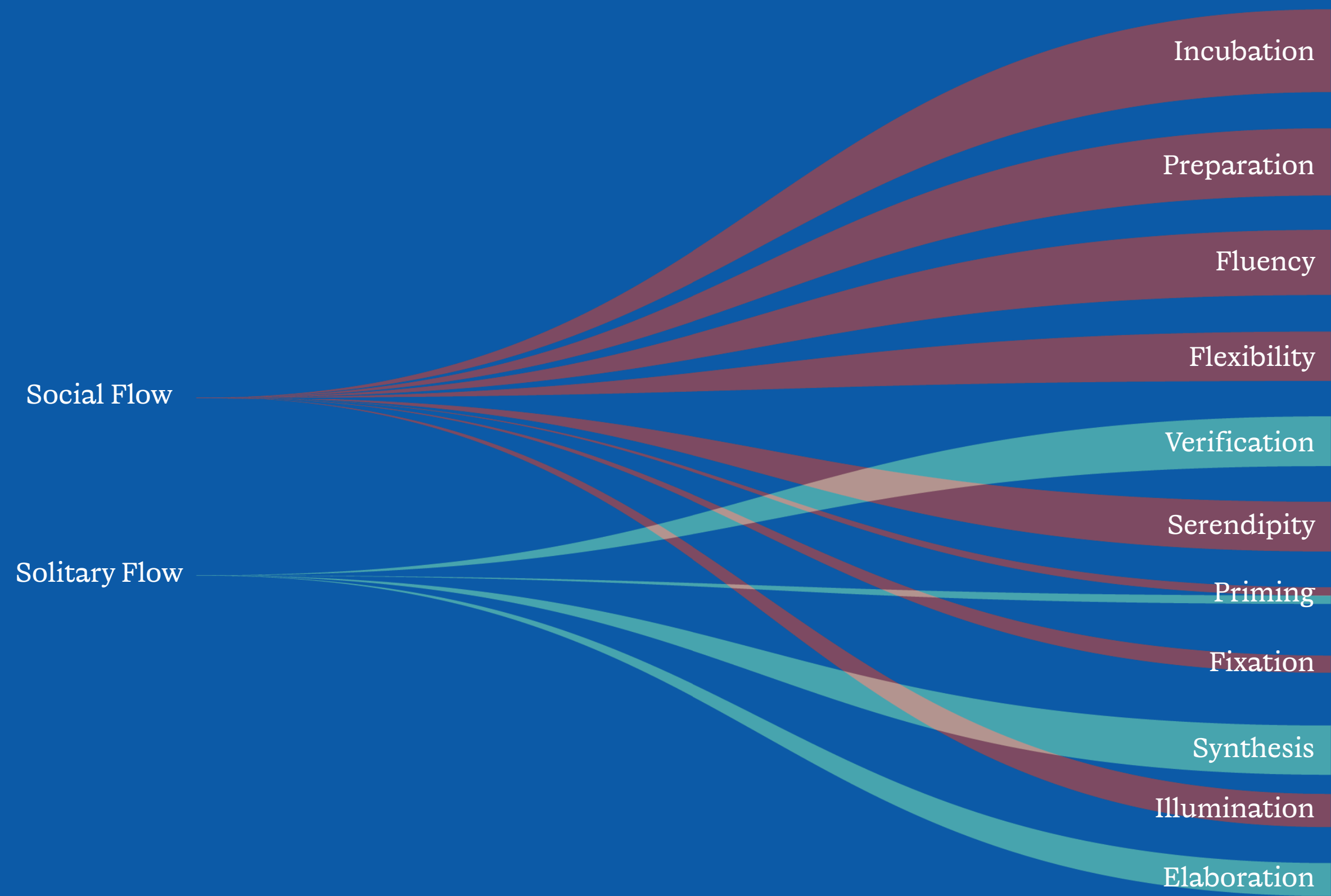

Flow Type

Stages

Designing for Flow

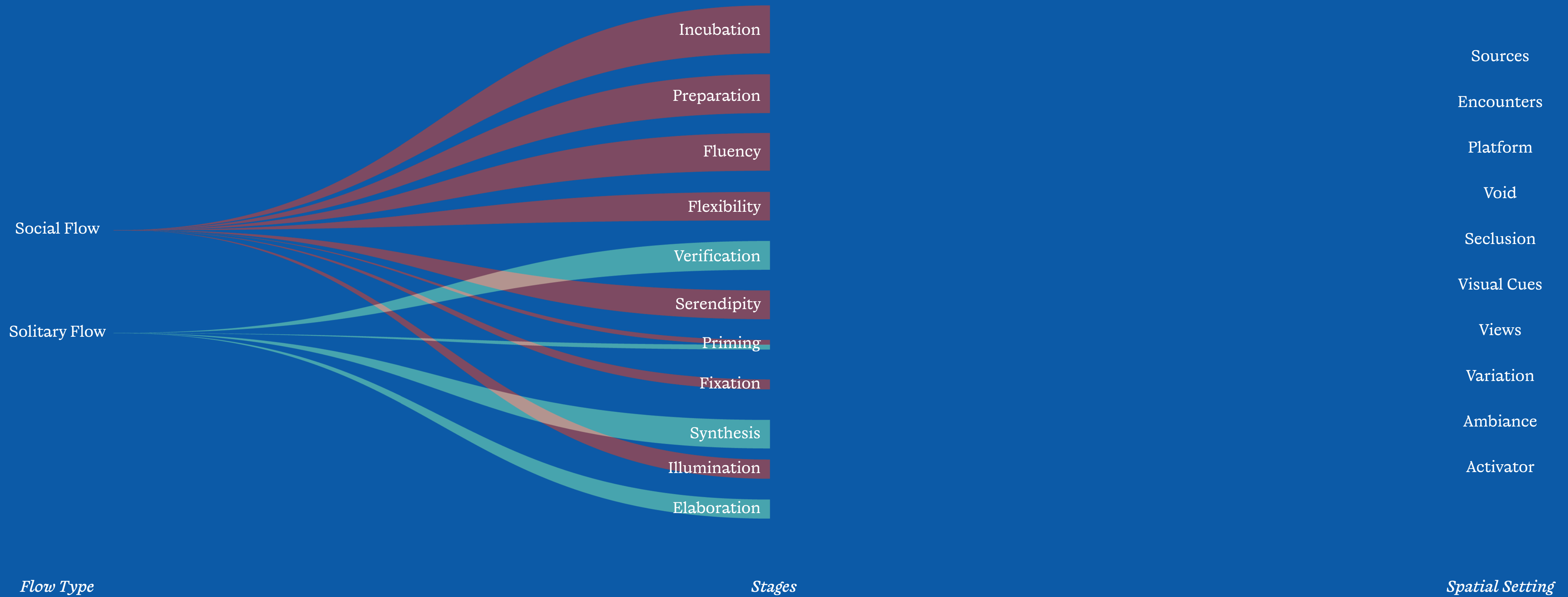

Designing for Flow

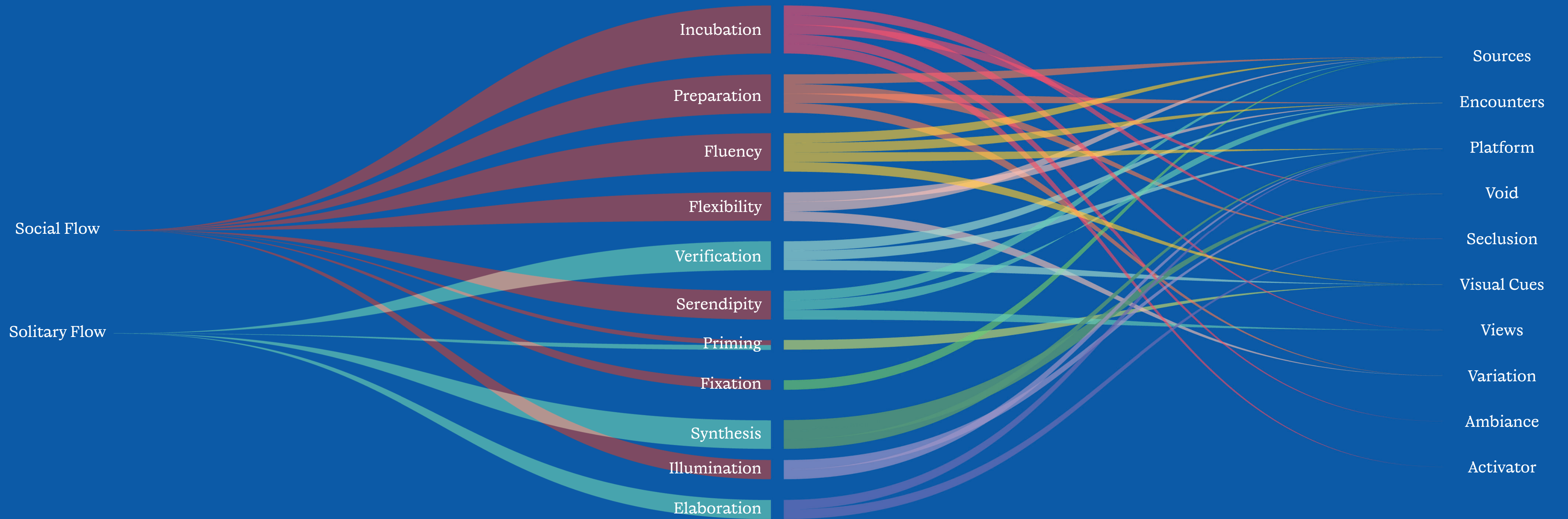

Flow Type

Stages

Spatial Setting

Designing for Flow

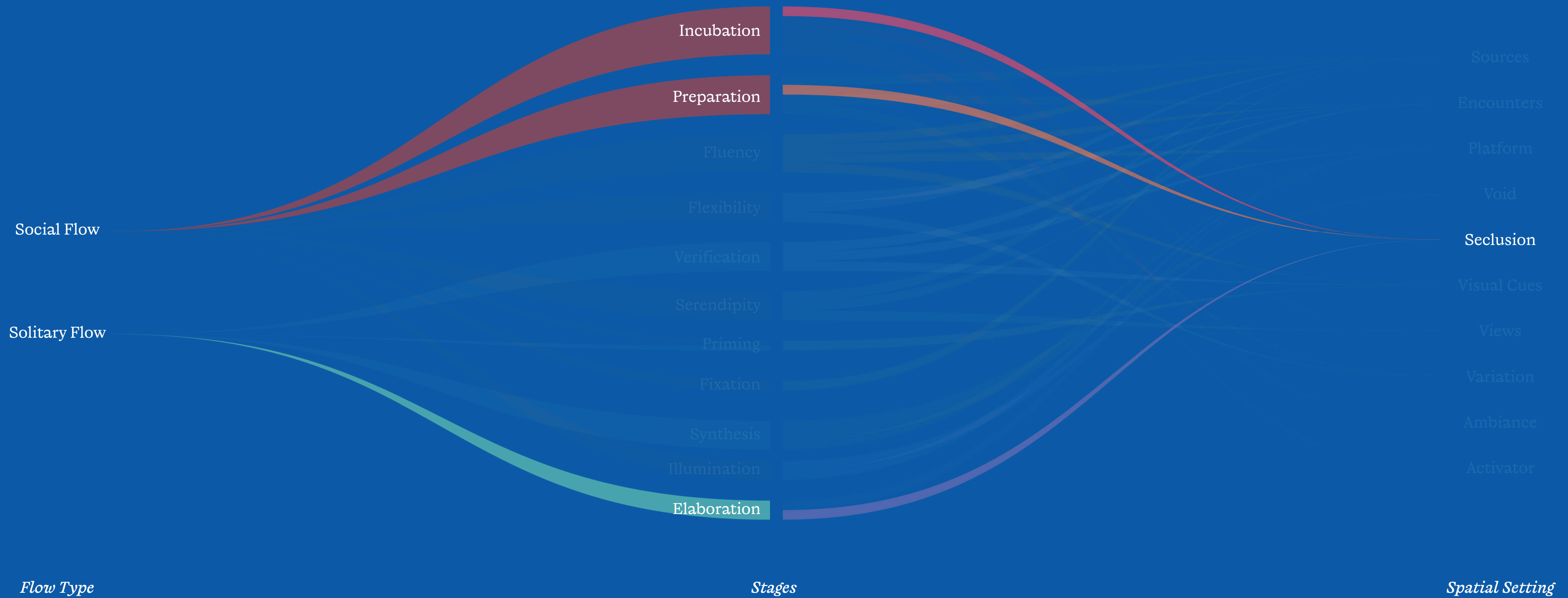

Designing for Flow

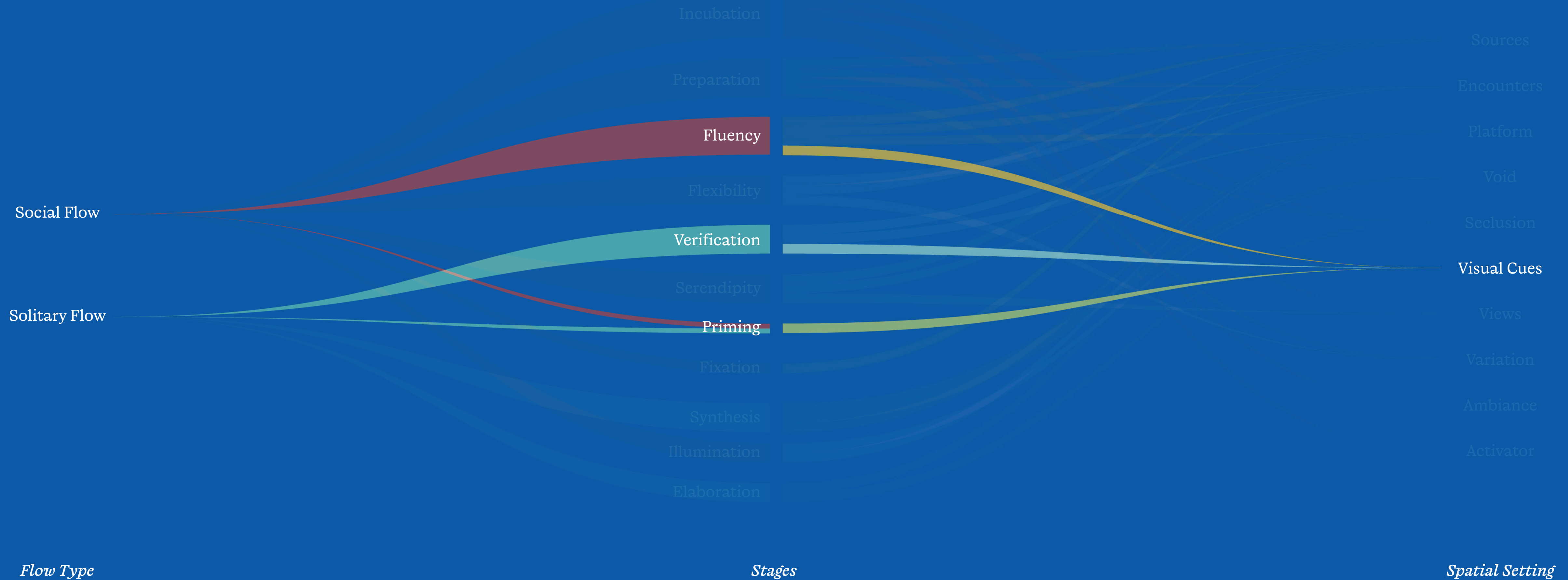

Solitary Flow Chamber



Solitary Flow Chamber



Blue light (6000k)

Solitary Flow Chamber



Blue light (6000k)

Cobalt blue (480nm) colour accent

Solitary Flow Chamber



Blue light (6000k)

Cobalt blue (480nm) colour accent

Aluminium foil layers in stud wall for Faraday cage effect

Solitary Flow Chamber



Blue light (6000k)

Cobalt blue (480nm) colour accent

Aluminium foil layers in stud wall for Faraday cage effect

Curvilinear forms

Solitary Flow Chamber



Blue light (6000k)

Cobalt blue (480nm) colour accent

Aluminium foil layers in stud wall for Faraday cage effect

Curvilinear forms

Cork accent walls

Solitary Flow Chamber



Blue light (6000k)

Cobalt blue (480nm) colour accent

Aluminium foil layers in stud wall for Faraday cage effect

Curvilinear forms

Cork accent walls

Exposed DLT ceiling w/ wool fibre + felt profile

<<Today design may exert a far-reaching influence on the nervous-make-up of generations.>>

Richard Neutra
Survival through design, 1954

Acknowledgements

With the support of
Prakash Konchady Shenoy
Vijaya Shenoy
Anne Louise Fanger
Inge Fanger Dürr

Construction of the project
Ir. Roel van de Pas
Ir. HL van der Meel
Dr. Ir. Elise van Dooren
Dr. Ir. Sabina Tanović

Special thanks to
Participants of the workshop
Anton Dobrevski
(for recommending Deep Work - Cal Newport)

Thank you

7.

Appendix



Results

Results // Ragnar

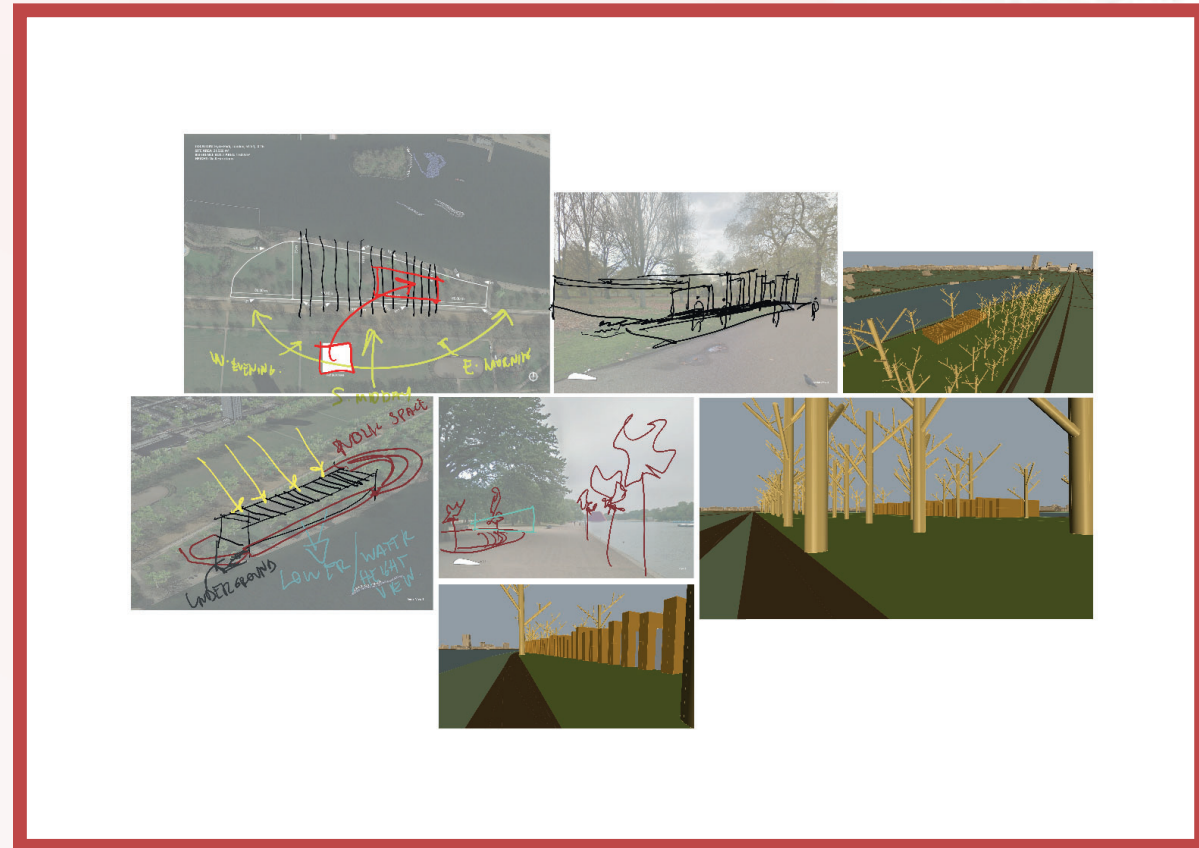

Digital Sketch

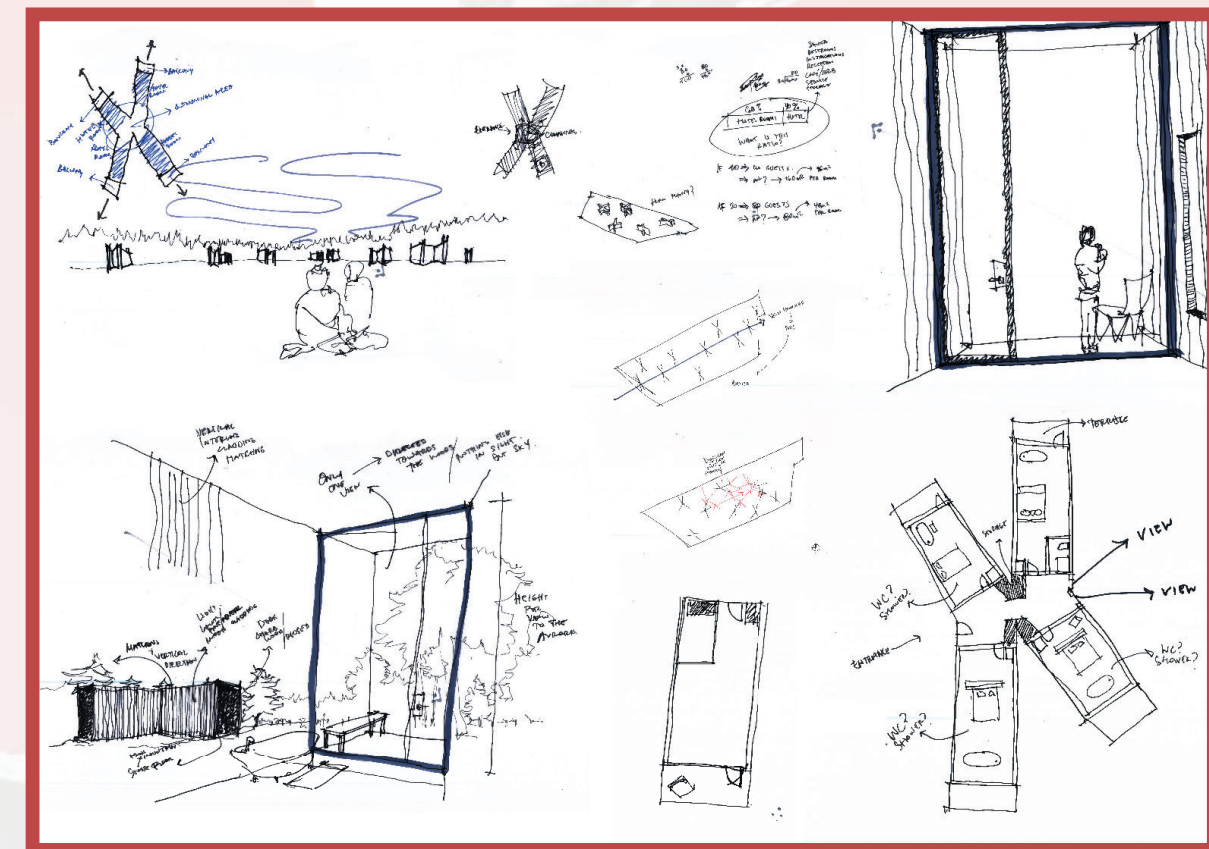

Analogue Sketch

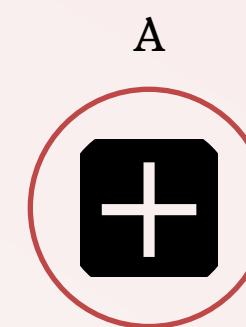

Quality

Results // Rhetta

Analogue Sketch

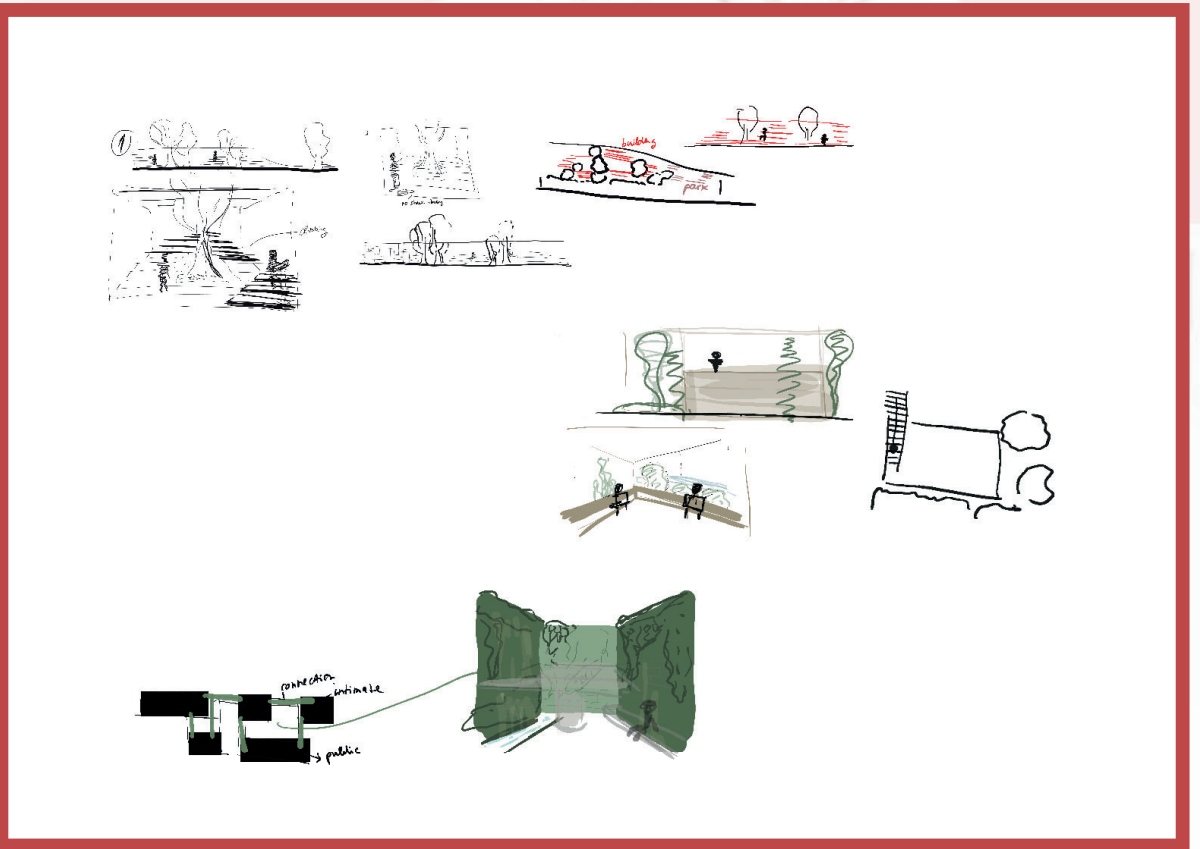

Digital Sketch

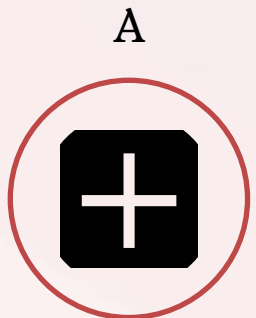

Quality

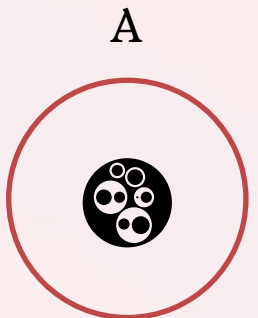

Quantity

Results // Marius

Analogue Sketch

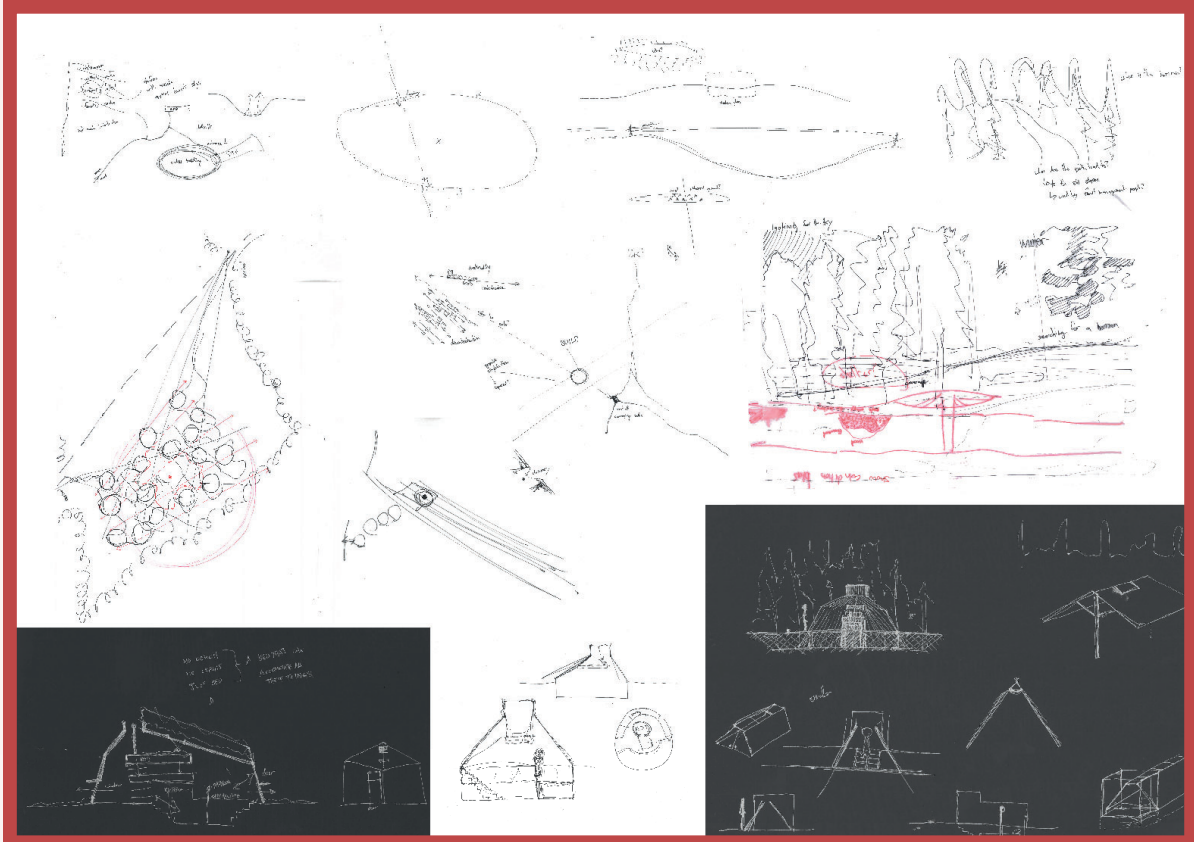

Digital Sketch

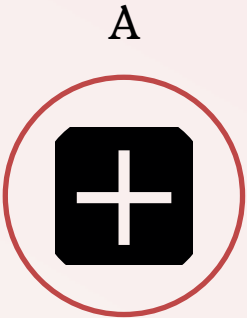
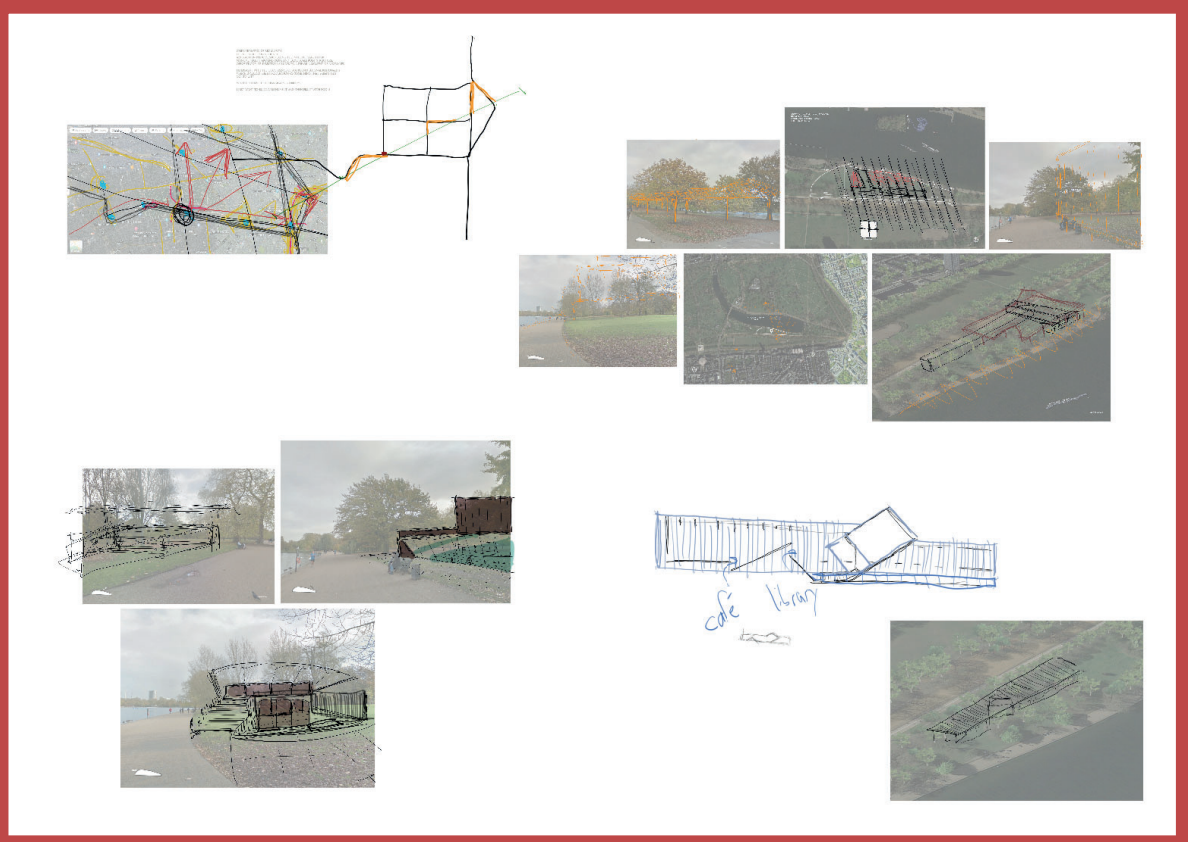

Quality

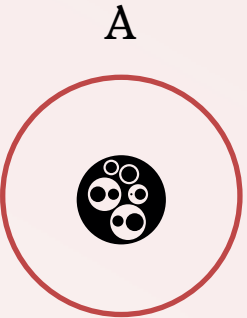

Quantity

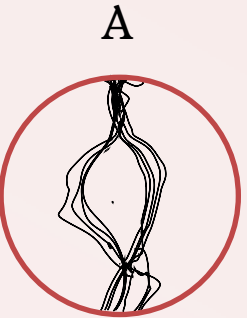

Flow

Results // Isaak

Digital Sketch

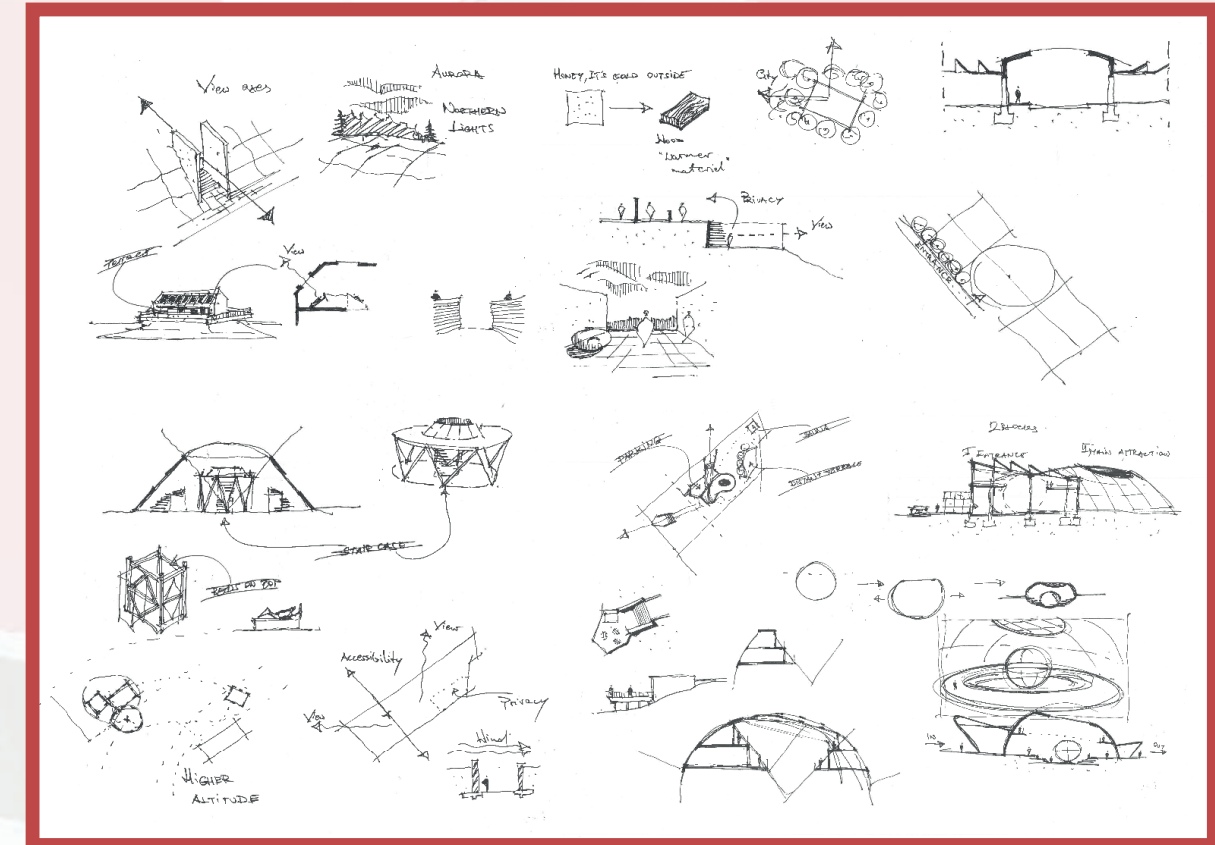
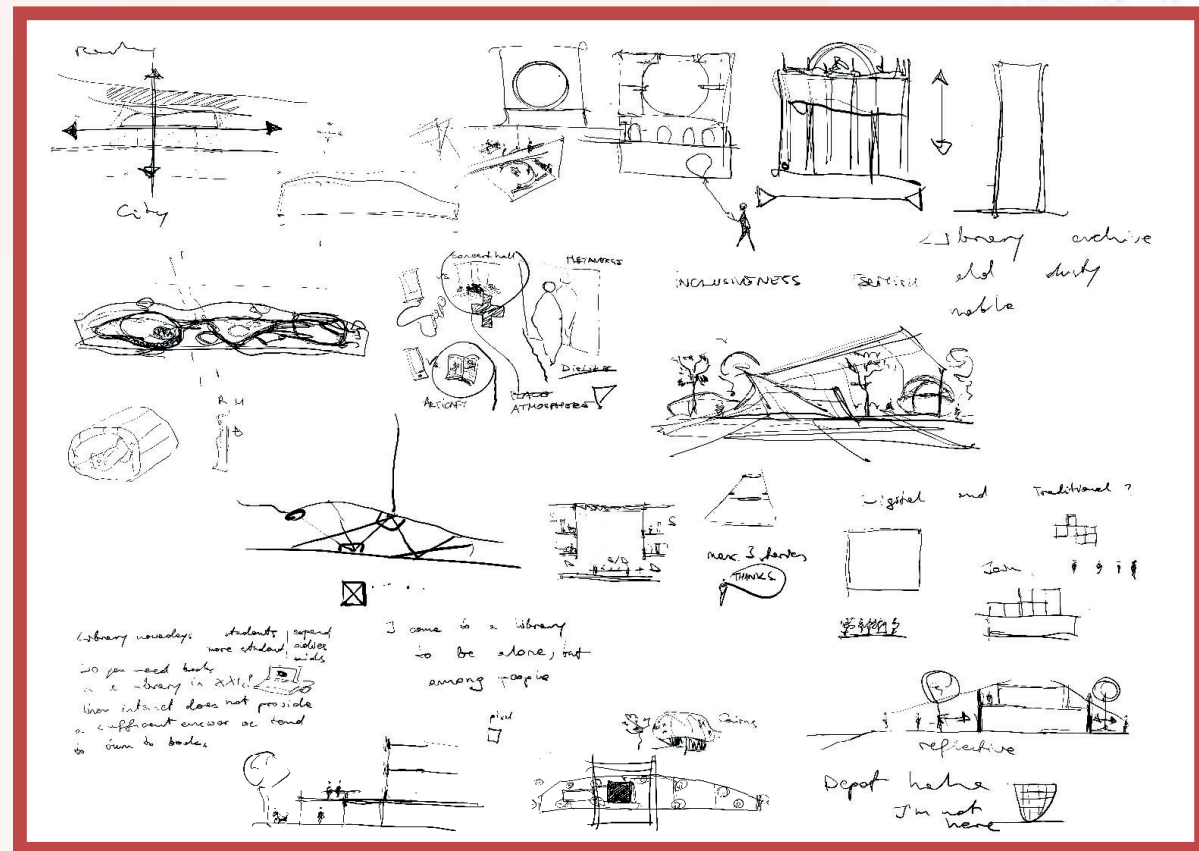

Analogue Sketch



Mastery
of the tool

Level 0

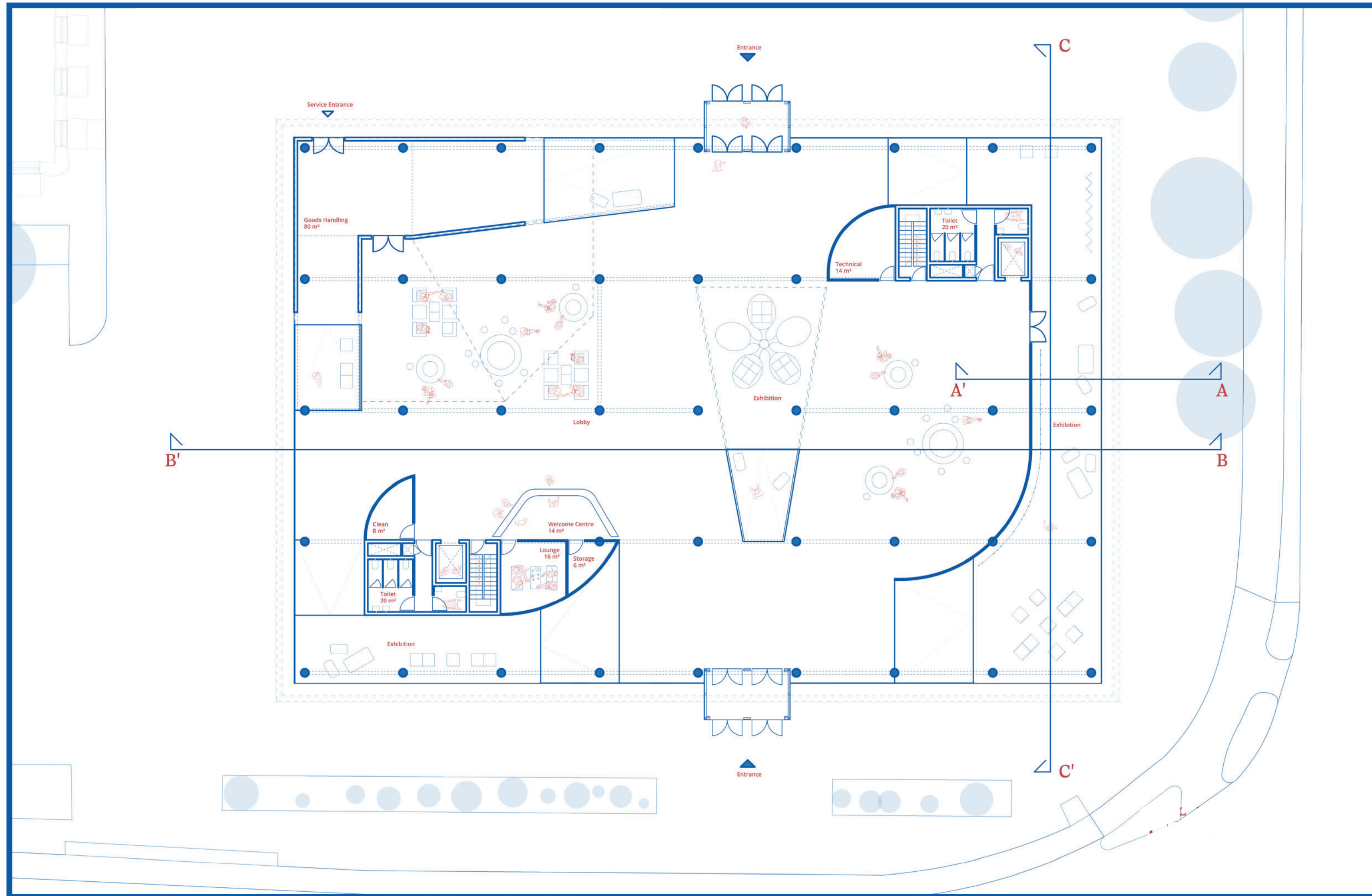

Level 1

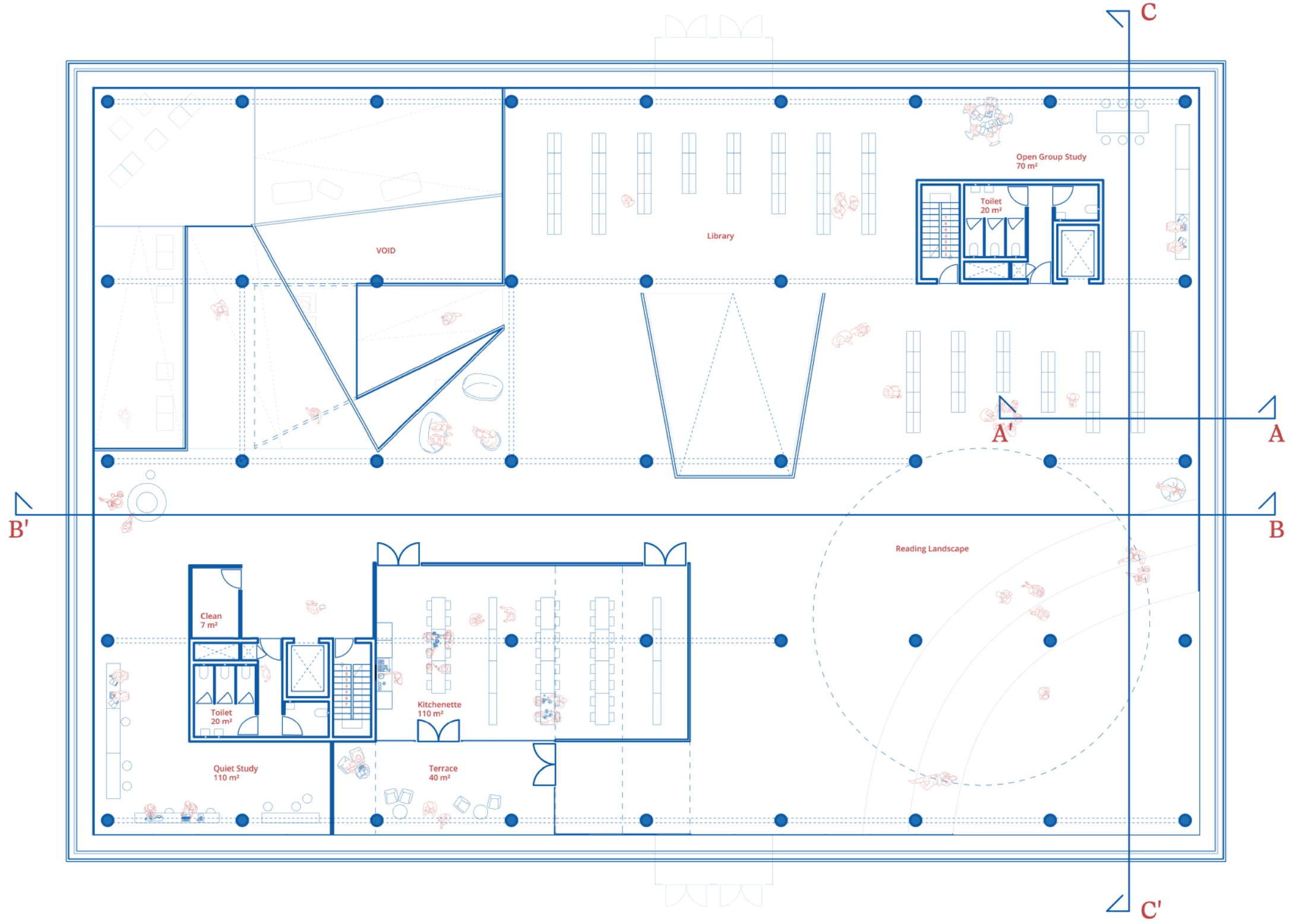

Level 3

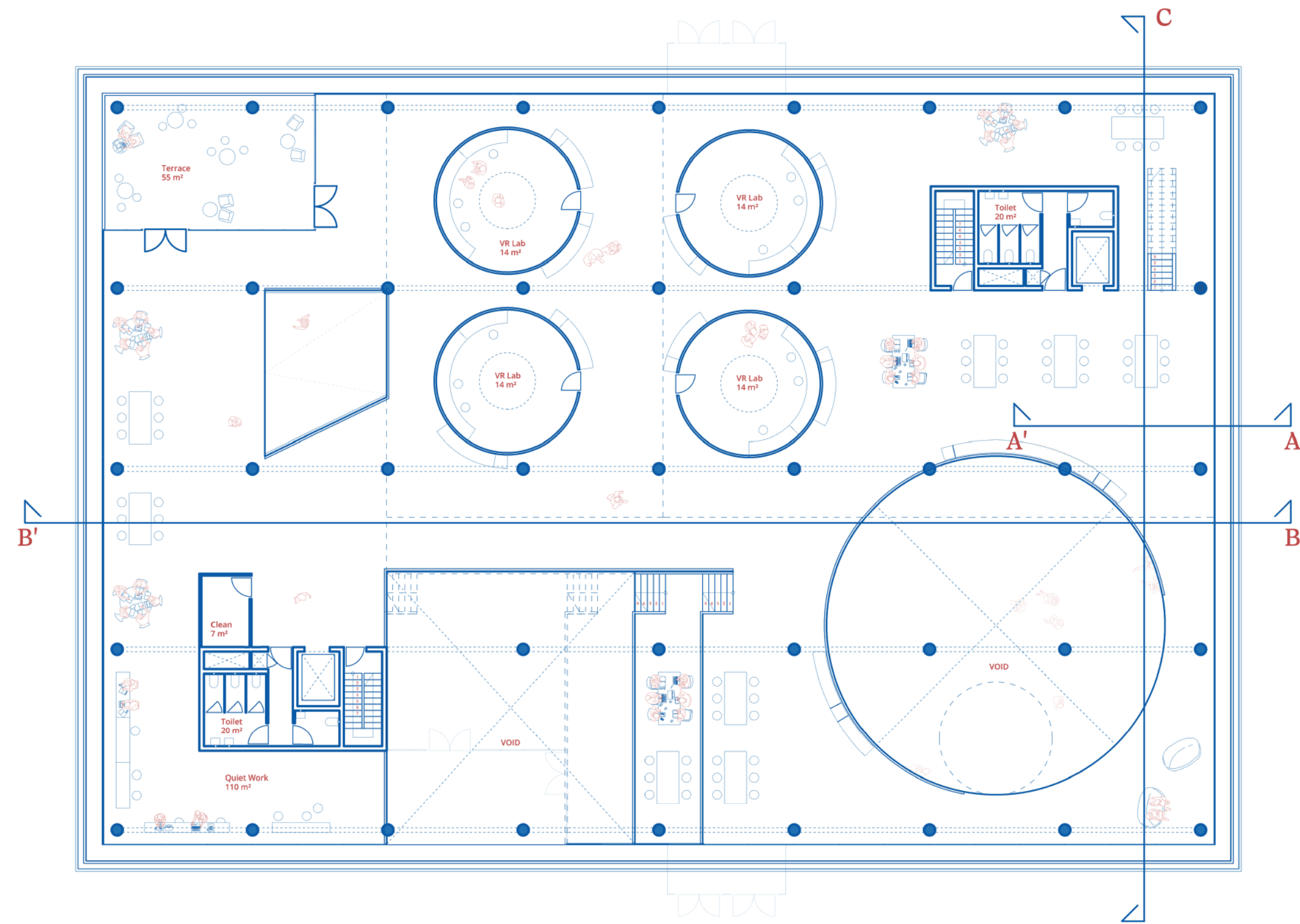

Level 4

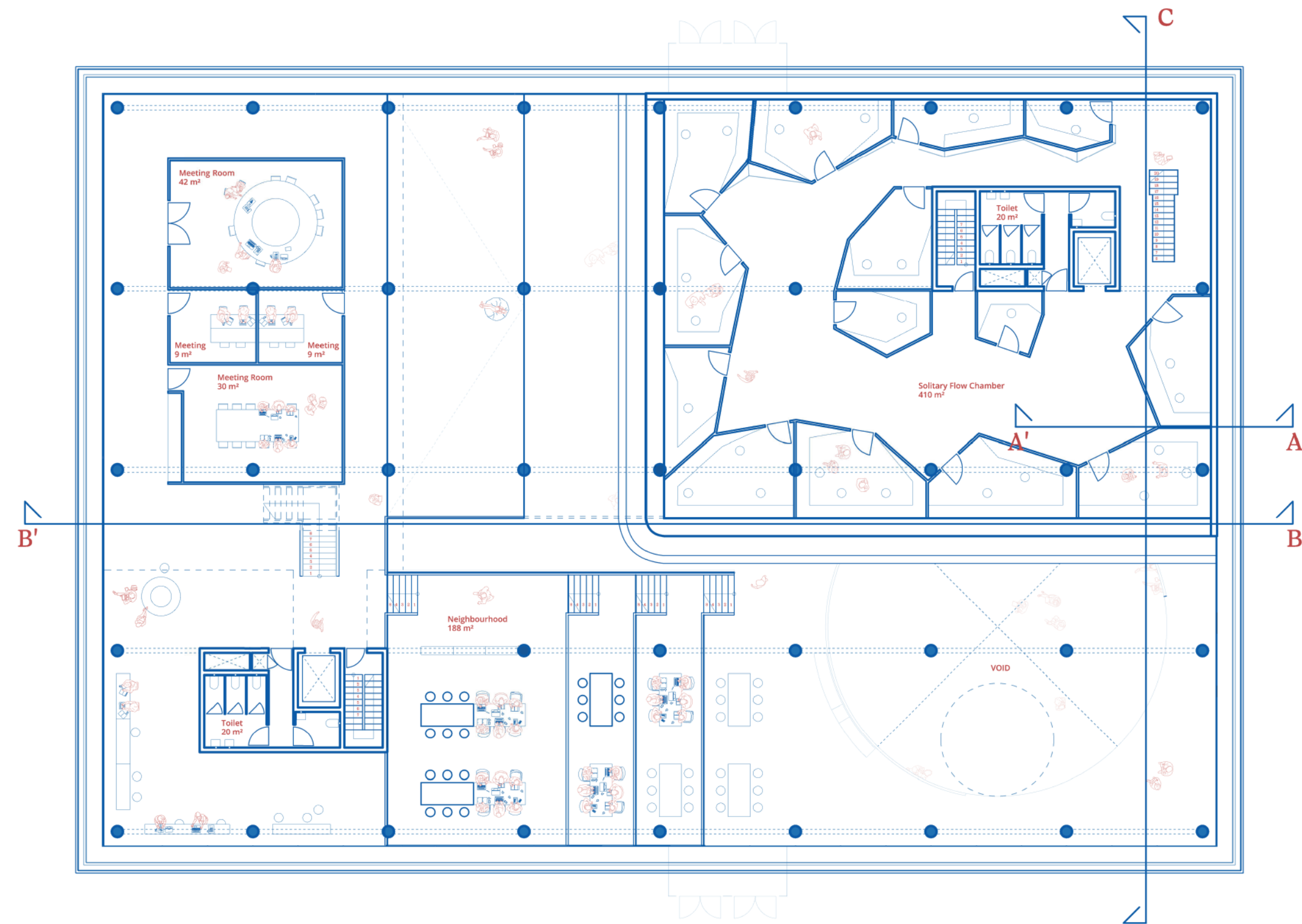

Level 5

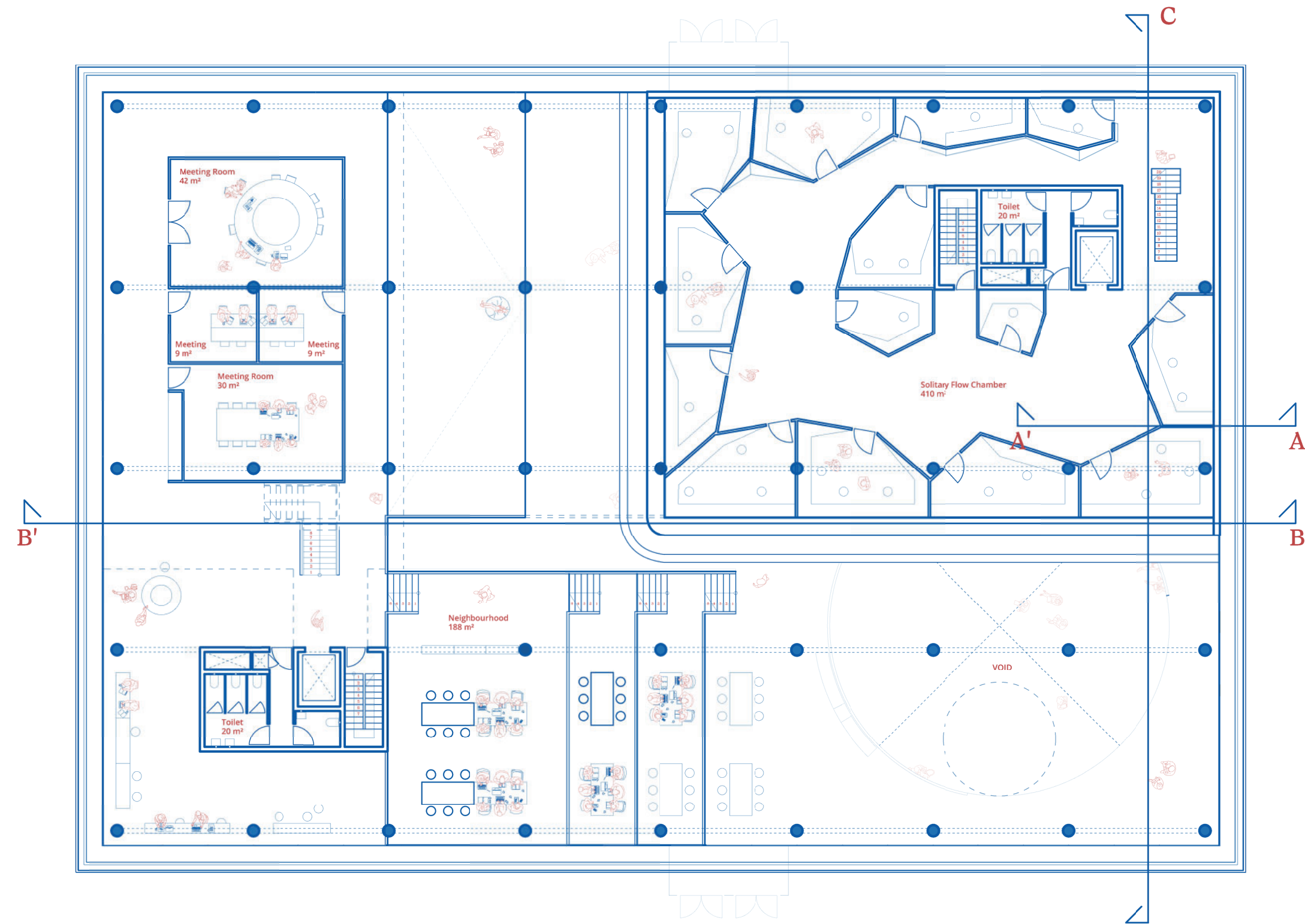

Level 4

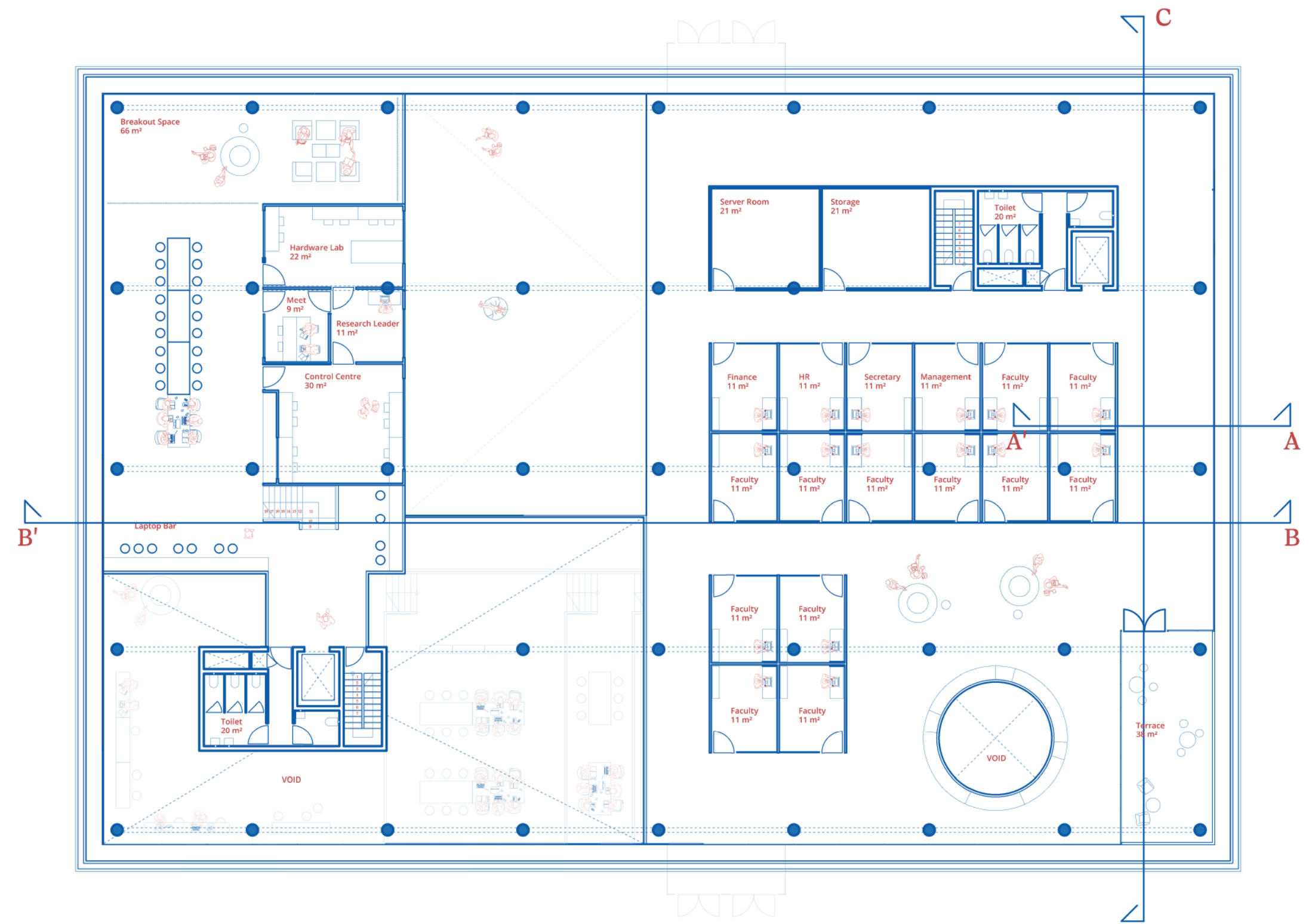

Level 5

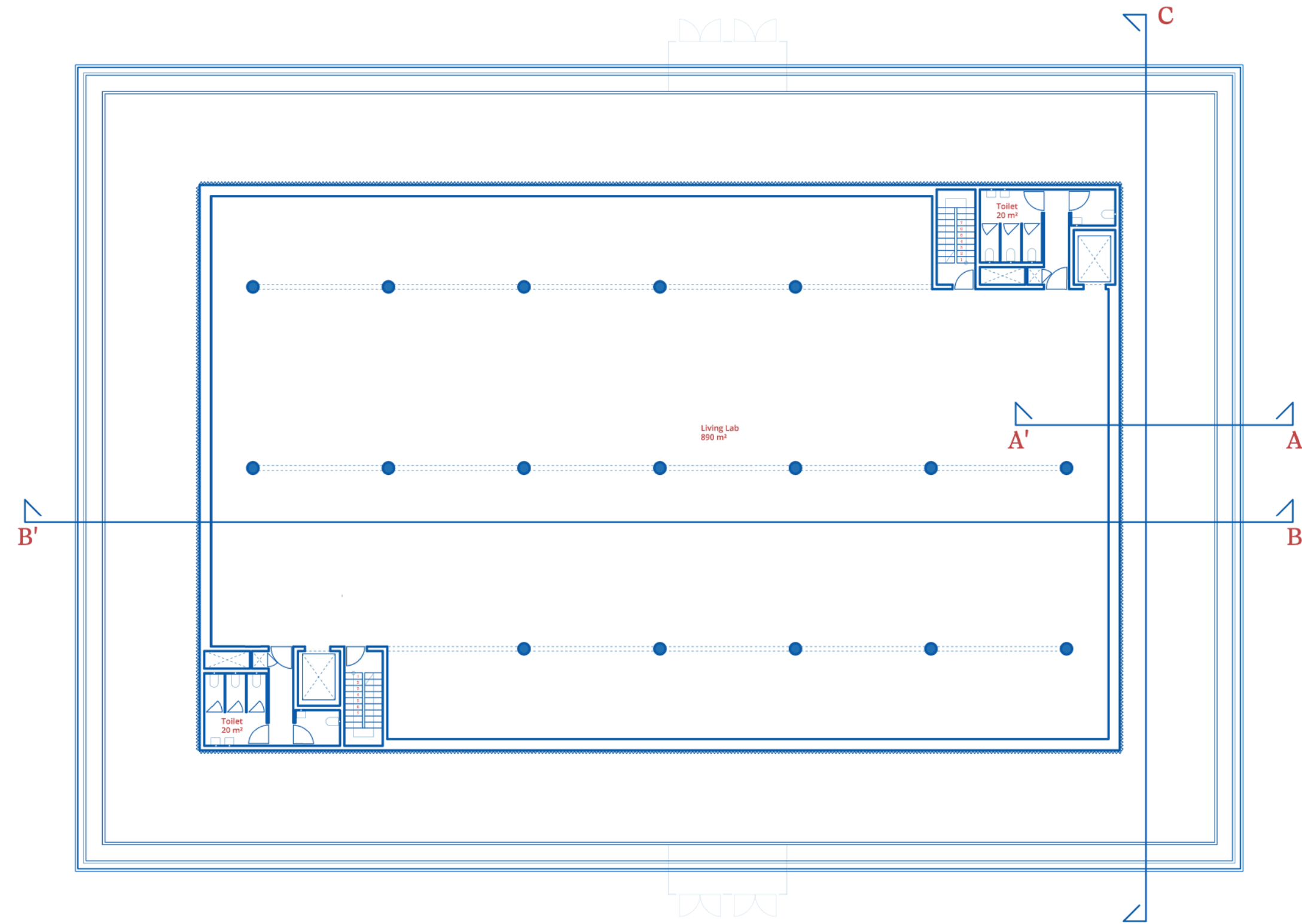

Master Plan

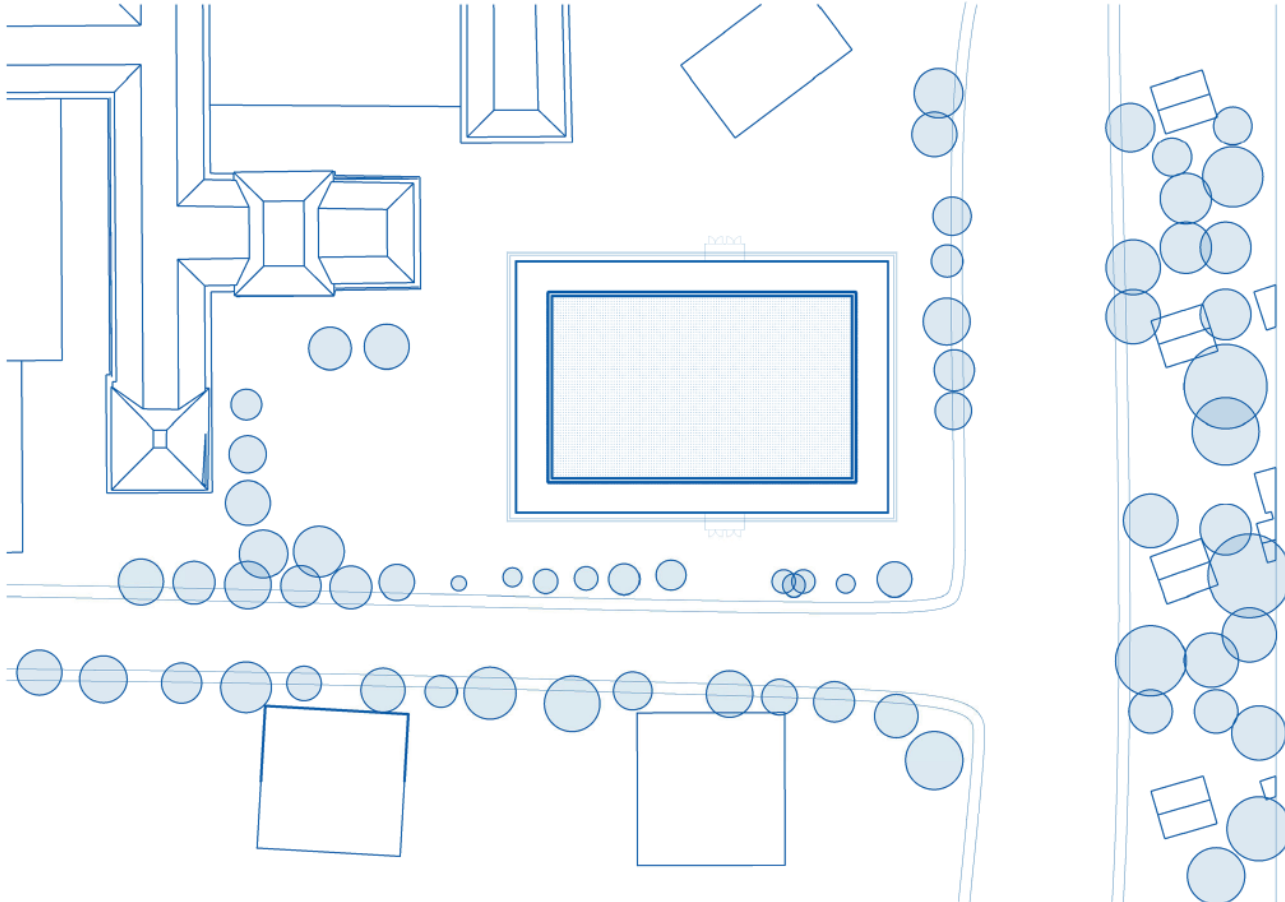

Structural Grid

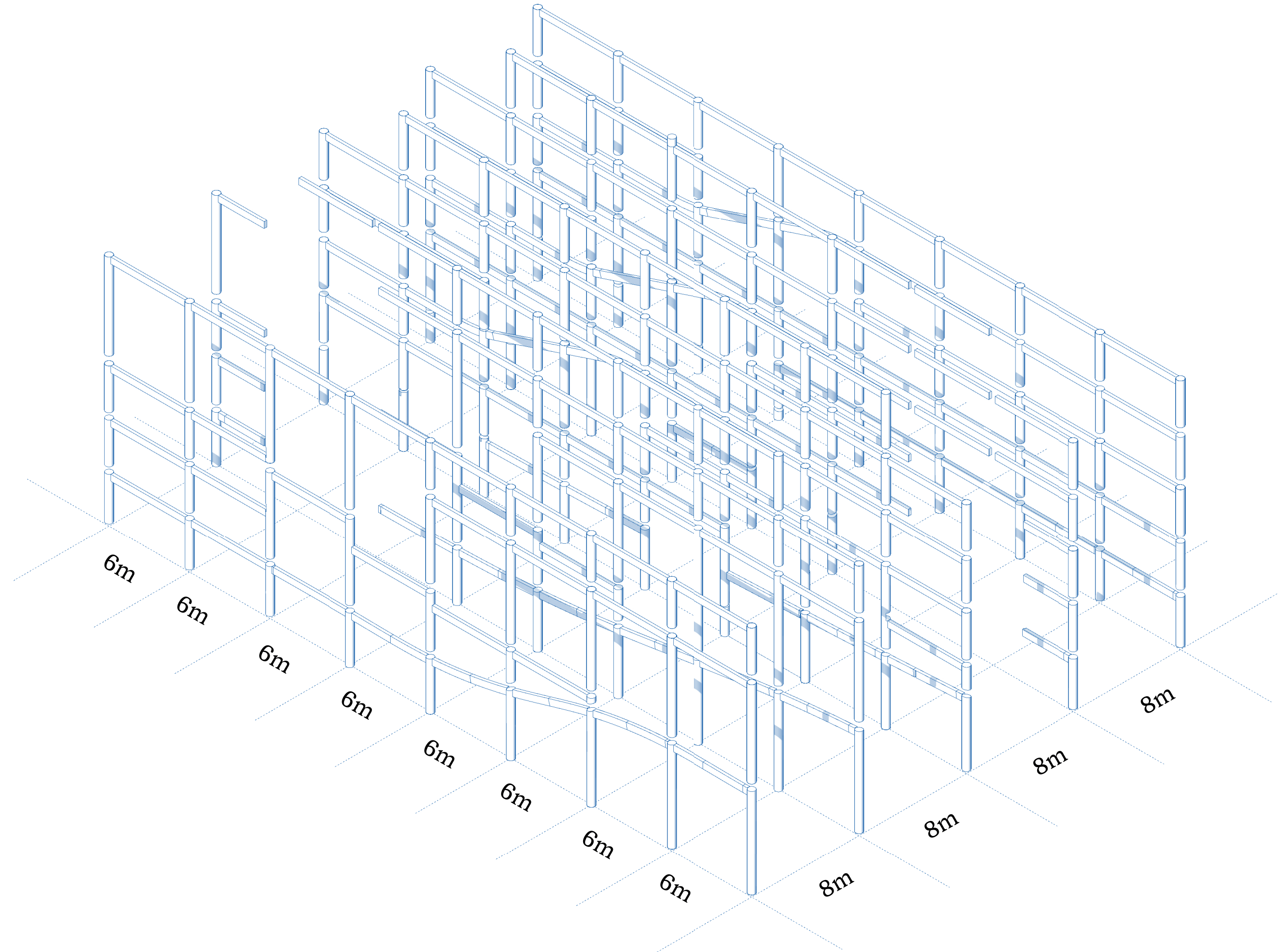

Reinforcement beams

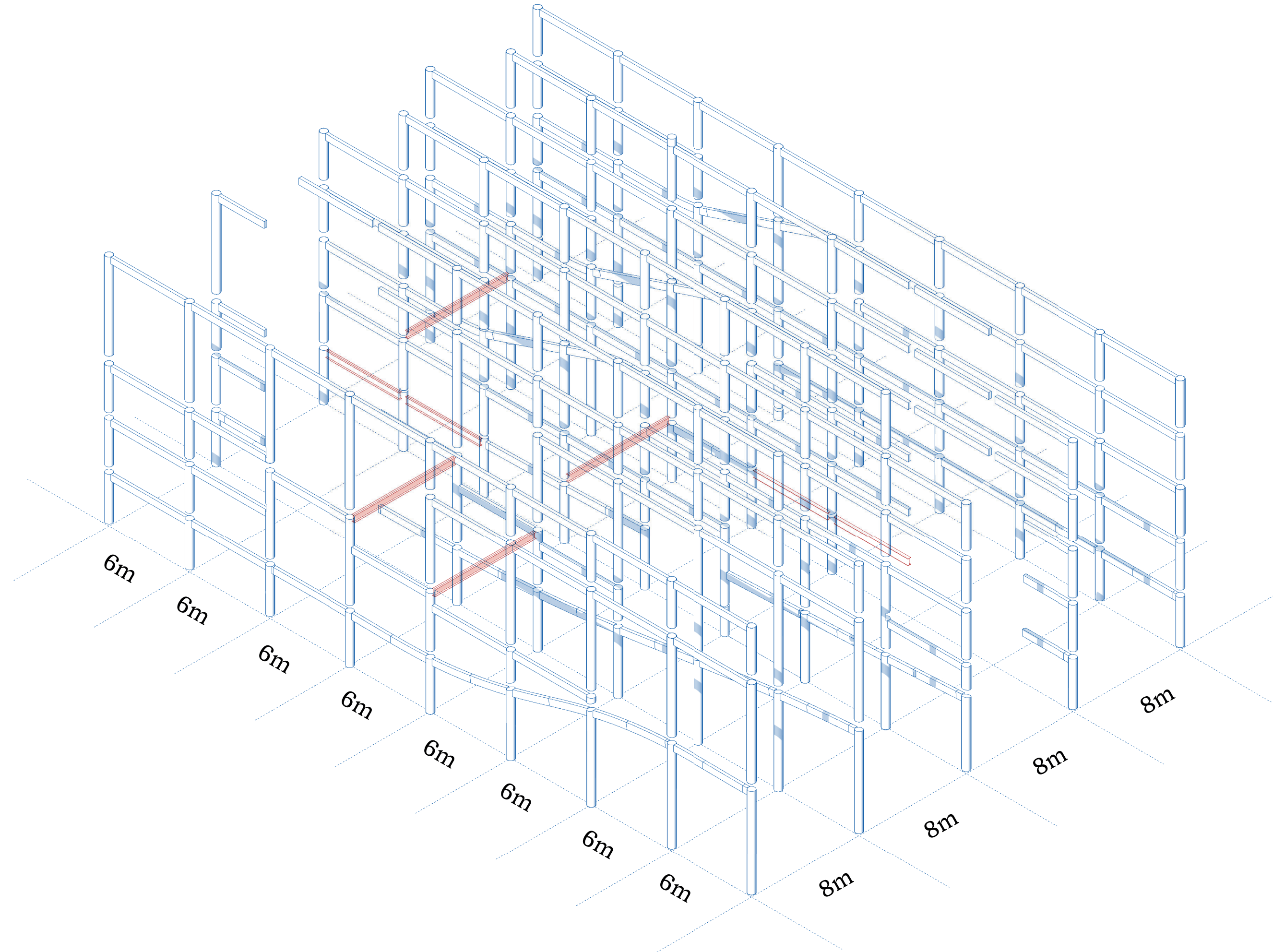

Assembly

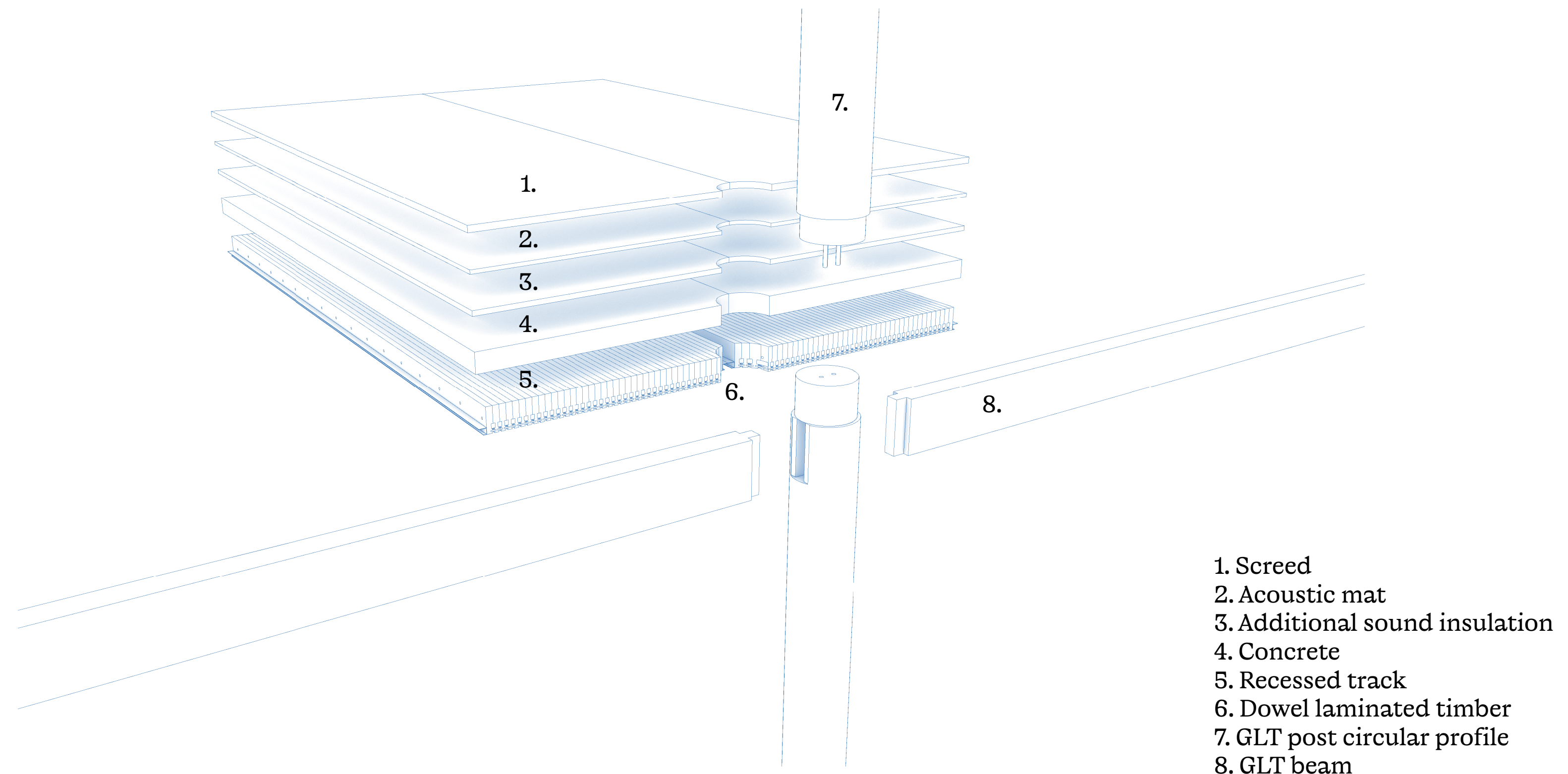

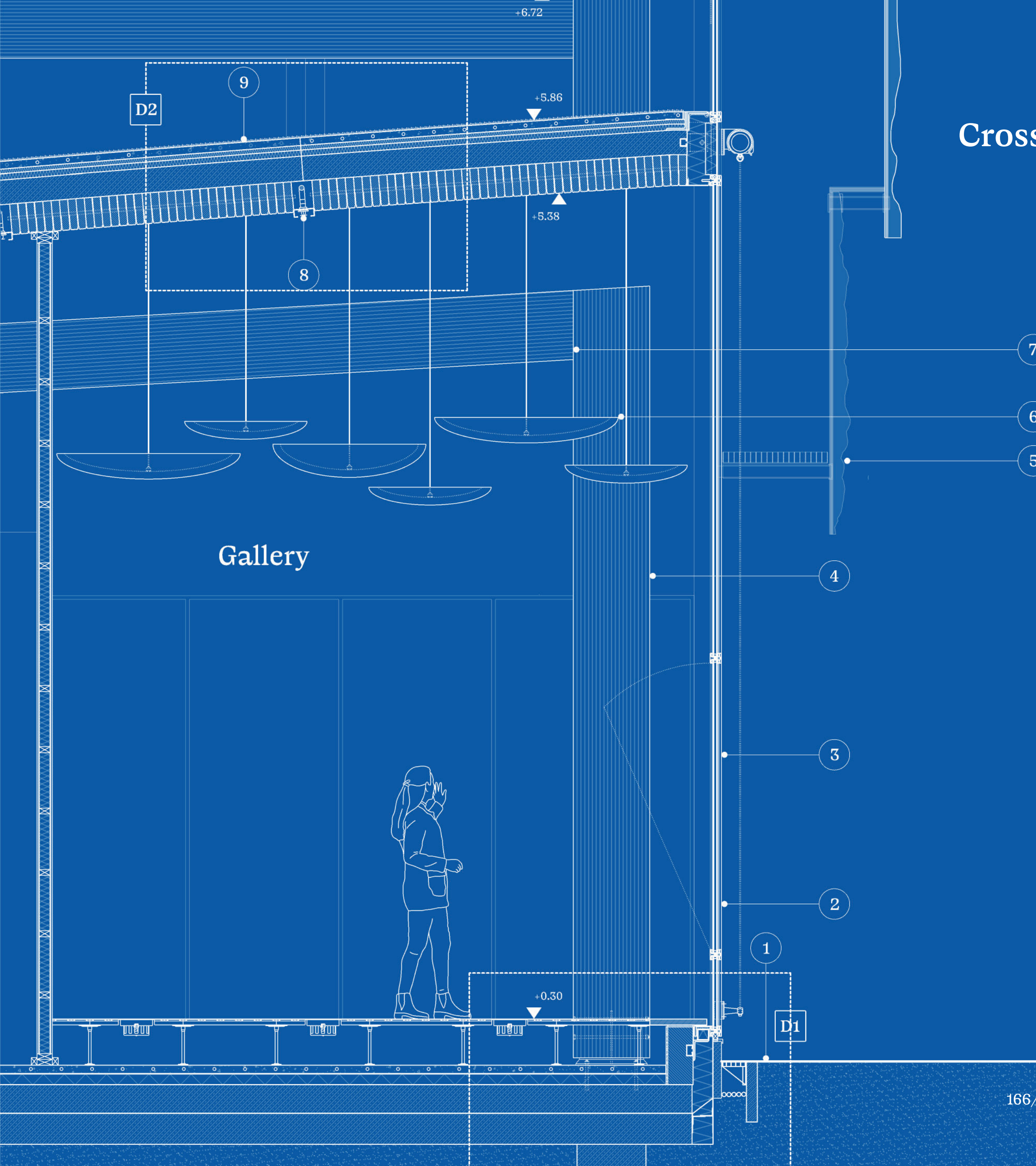

Cross Section A-A'

1. Connection detail to ground
2. Hopper window
3. Double glazing
4. Glulam column Ø 500mm circular profile
5. Cast glass facade
6. Acoustic rock wool baffle system without frame, Ø 1200 – 800 mm (t): 50mm
7. Glulam beam 450 x 200 mm
8. Recessed track lighting
9. Carpet floor covering 13mm, screed with underfloor heating 50mm, mineral fibre sound insulation 30mm, additional mineral fibre sound insulation 40mm, concrete 100mm, Dowel laminated timber (curved custom profile) 160mm
10. Floor covering 13mm, screed with underfloor heating 37mm, mineral fibre sound insulation 30mm, additional mineral fibre sound insulation 40mm, concrete 100mm, dowel laminated timber (bullnose custom profile) 160mm
11. Steel grill walkway for maintenance
12. Casted glass to concrete slab connection
13. Horizontal glass elements to close facade for climate control
14. Larch facade cladding 19mm, horizontal battens 35mm, vertical battens 15mm, facade membrane and gypsum fibreboard 2 x 13mm, timber studs, thermal insulation 200mm, gypsum fibreboard and aluminium foil 13mm, gypsum fibreboard 13mm, floor covering 13mm
15. Carpet floor covering 13mm, raised flooring 150mm, screed with underfloor heating 50mm, mineral fibre sound insulation 30mm, additional mineral fibre sound insulation 40mm, concrete 100mm, Dowel laminated timber (acoustic square w/ wood fibre) 160mm
16. Acoustic slat wood panel 11m, timber stud walls with two layers of 5mm aluminum foil on either side, acoustic slat wood panels 11m
17. AirFuse swirl diffuser (UFAD ventilation system)
18. Floor covering 13mm, raised flooring 150mm, screed with underfloor heating 50mm, mineral fibre sound insulation 30mm, additional mineral fibre sound insulation 40mm, concrete 100mm, dowel laminated timber (acoustic square w/ wood fibre + felt profile) 160mm

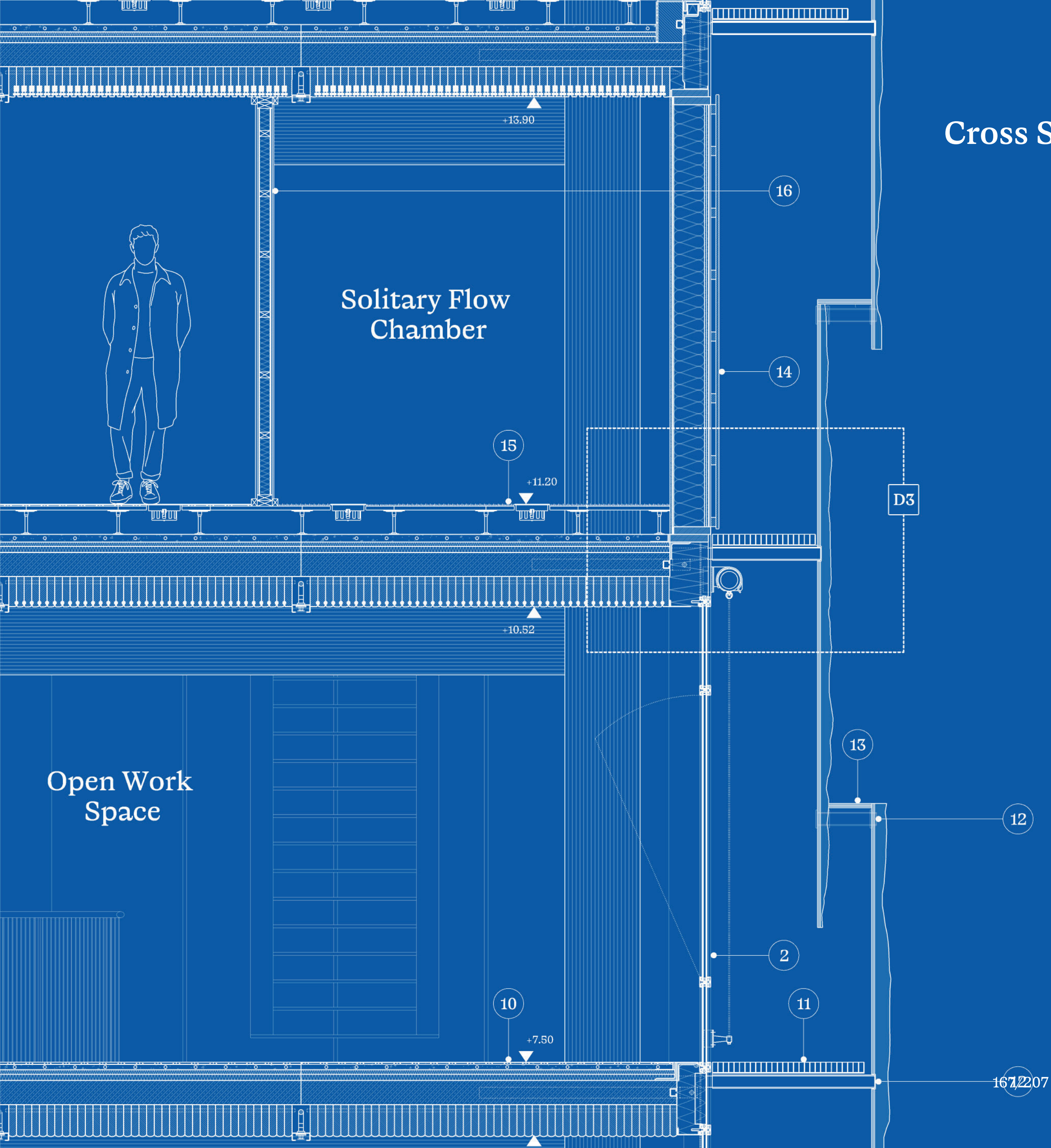

1. Connection detail to ground
2. Hopper window
3. Double glazing
4. Glulam column Ø 500mm circular profile
5. Cast glass facade
6. Acoustic rock wool baffle system without frame, Ø 1200 – 800 mm (t): 50mm
7. Glulam beam 450 x 200 mm
8. Recessed track lighting
9. Carpet floor covering 13mm, screed with underfloor heating 50mm, mineral fibre sound insulation 30mm, additional mineral fibre sound insulation 40mm, concrete 100mm, Dowel laminated timber (curved custom profile) 160mm
10. Floor covering 13mm, screed with underfloor heating 37mm, mineral fibre sound insulation 30mm, additional mineral fibre sound insulation 40mm, concrete 100mm, dowel laminated timber (bullnose custom profile) 160mm
11. Steel grill walkway for maintenance
12. Casted glass to concrete slab connection
13. Horizontal glass elements to close facade for climate control
14. Larch facade cladding 19mm, horizontal battens 35mm, vertical battens 15mm, facade membrane and gypsum fibreboard 2 x 13mm, timber studs, thermal insulation 200mm, gypsum fibreboard and aluminium foil 13mm, gypsum fibreboard 13mm, floor covering 13mm
15. Carpet floor covering 13mm, raised flooring 150mm, screed with underfloor heating 50mm, mineral fibre sound insulation 30mm, additional mineral fibre sound insulation 40mm, concrete 100mm, Dowel laminated timber (acoustic square w/ wood fibre) 160mm
16. Acoustic slat wood panel 11m, timber stud walls with two layers of 5mm aluminum foil on either side, acoustic slat wood panels 11m
17. AirFuse swirl diffuser (UFAD ventilation system)
18. Floor covering 13mm, raised flooring 150mm, screed with underfloor heating 50mm, mineral fibre sound insulation 30mm, additional mineral fibre sound insulation 40mm, concrete 100mm, dowel laminated timber (acoustic square w/ wood fibre + felt profile) 160mm

Cross Section A-A'

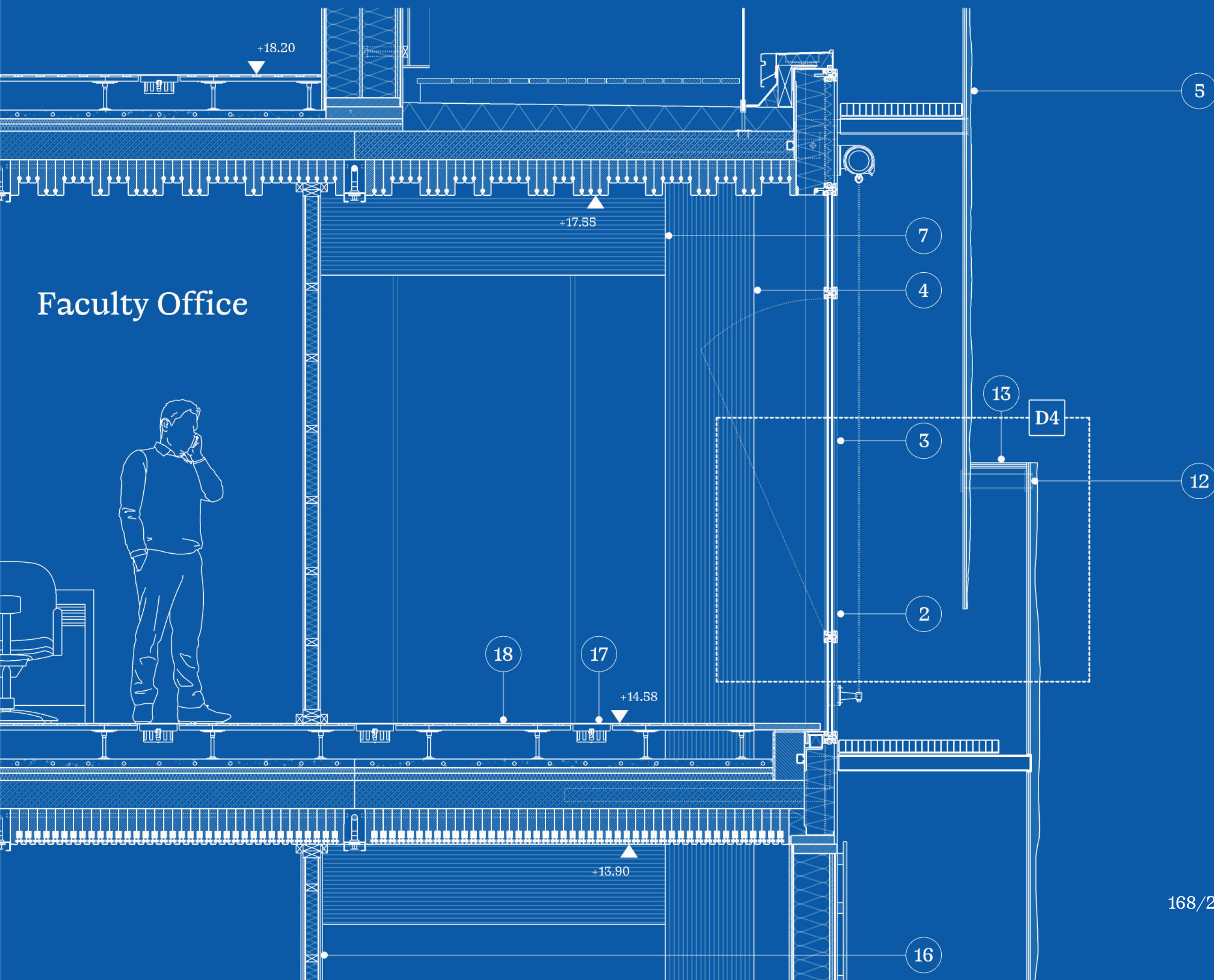

1. Connection detail to ground

2. Hopper window

3. Double glazing

4. Glulam column Ø 500mm circular profile

5. Cast glass facade

6. Acoustic rock wool baffle system without frame, Ø 1200 – 800 mm (t): 50mm

7. Glulam beam 450 x 200 mm

8. Recessed track lighting

9. Carpet floor covering 13mm, screed with underfloor heating 50mm, mineral fibre sound insulation 30mm, additional mineral fibre sound insulation 40mm, concrete 100mm, Dowel laminated timber (curved custom profile) 160mm

10. Floor covering 13mm, screed with underfloor heating 37mm, mineral fibre sound insulation 30mm, additional mineral fibre sound insulation 40mm, concrete 100mm, dowel laminated timber (bullnose custom profile) 160mm

11. Steel grill walkway for maintenance

12. Casted glass to concrete slab connection

13. Horizontal glass elements to close facade for climate control

14. Larch facade cladding 19mm, horizontal battens 35mm, vertical battens 15mm, facade membrane and gypsum fibreboard 2 x 13mm, timber studs, thermal insulation 200mm, gypsum fibreboard and aluminium foil 13mm, gypsum fibreboard 13mm, floor covering 13mm

15. Carpet floor covering 13mm, raised flooring 150mm, screed with underfloor heating 50mm, mineral fibre sound insulation 30mm, additional mineral fibre sound insulation 40mm, concrete 100mm, Dowel laminated timber (acoustic square w/ wood fibre) 160mm

16. Acoustic slat wood panel 11m, timber stud walls with two layers of 5mm aluminum foil on either side, acoustic slat wood panels 11m

17. AirFuse swirl diffuser (UFAD ventilation system)

18. Floor covering 13mm, raised flooring 150mm, screed with underfloor heating 50mm, mineral fibre sound insulation 30mm, additional mineral fibre sound insulation 40mm, concrete 100mm, dowel laminated timber (acoustic square w/ wood fibre + felt profile) 160mm

Cross Section A-A'

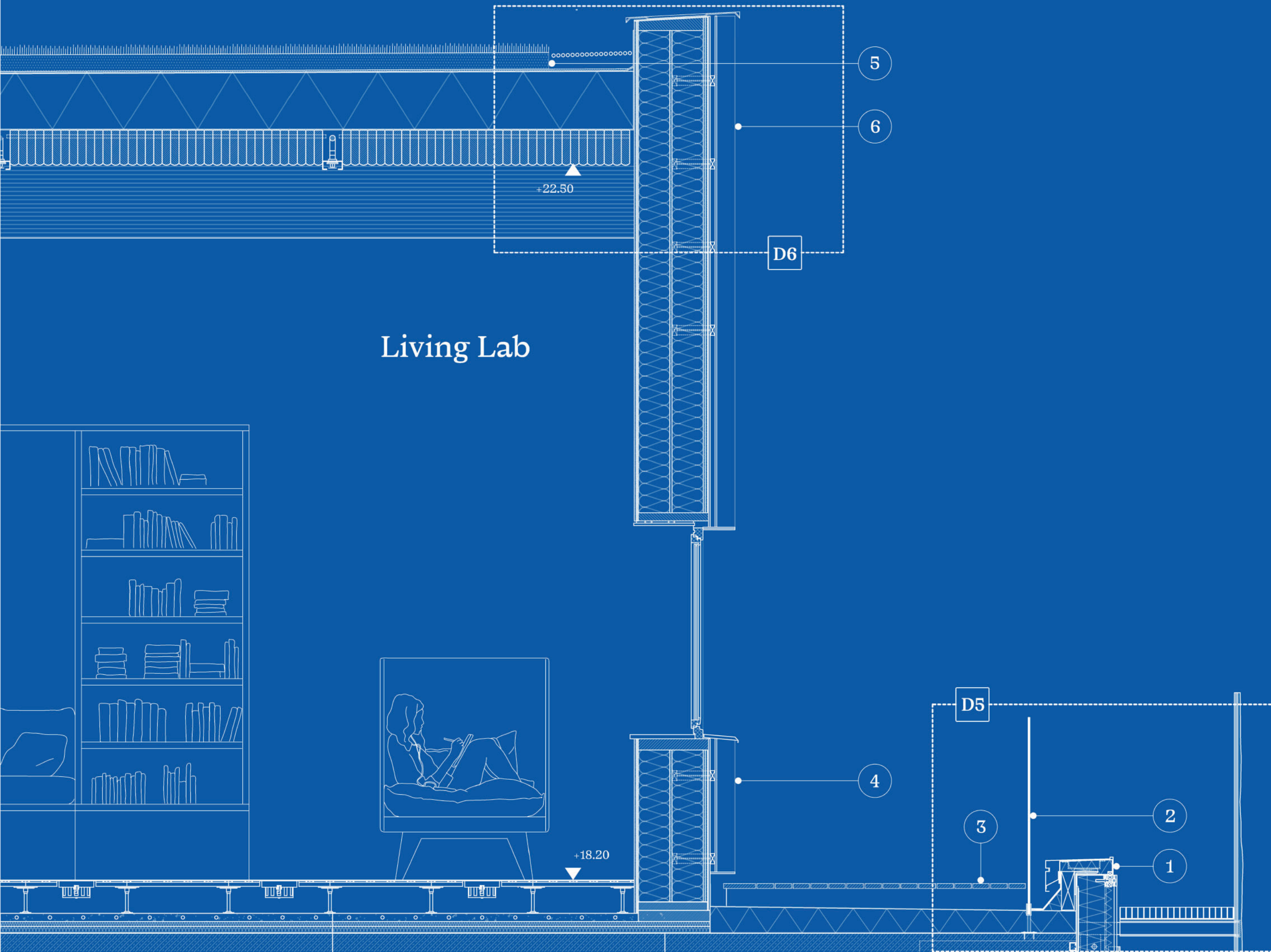

1. Typical flat roof junction

2. Laminated safety glass railing

3. Larch untreated 30mm, solid structural timber conical 100-120mm, protective mat, sealing membrane, sound insulation 50 - 20mm, concrete 160mm, dowel laminated timber (random fluted w/ mineral wool) 160mm

4. Facade cladding, aluminium pyramid-profiled cladding with dichroic powdered finish

5. Extensive vegetation 100mm, drainage 10mm, waterproofing membrane 2 x 5mm, waterproofing self adhesive membrane with heat shield 3mm, thermal insulation 350mm, vapour barrier 3.8mm, dowel laminated timber (bullnose custom profile) 160mm

Designing for Flow

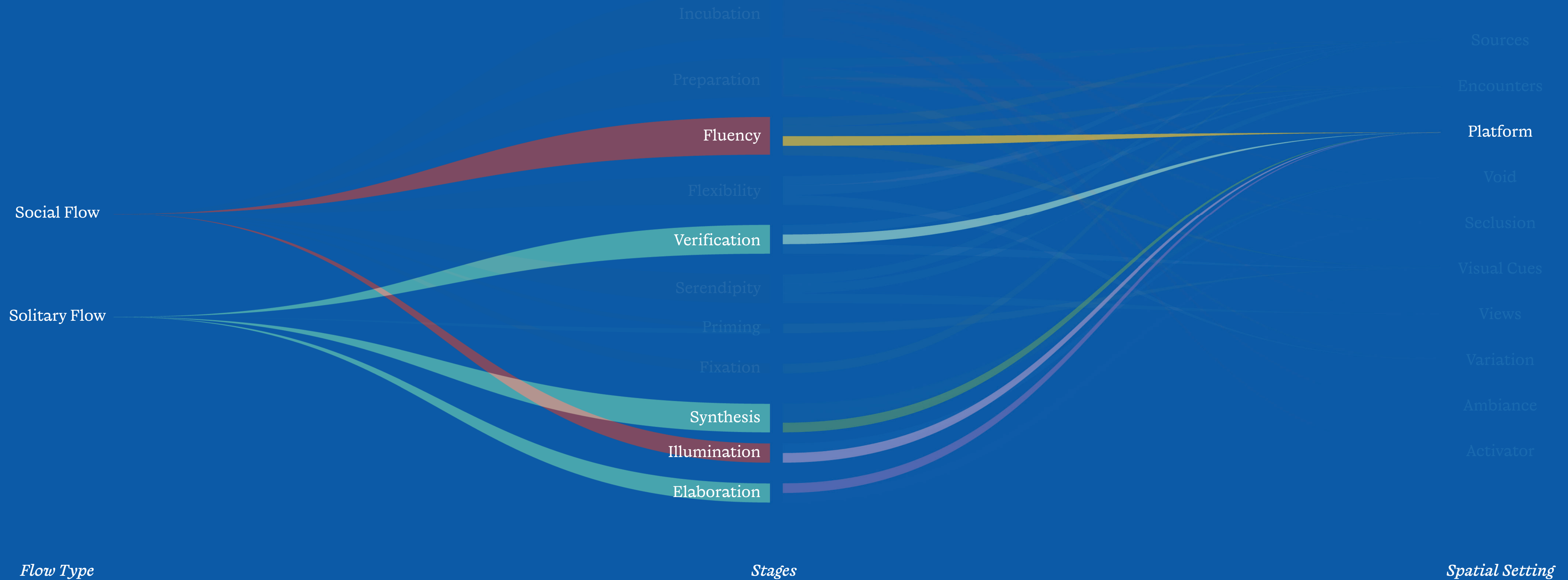

The Neighbourhood



Natural materials: timber

Varied ceiling height (3 - 7.2 m)

Serendipity

Writeable glass surface

Connexity

Bodily Awareness

Rat brain cells

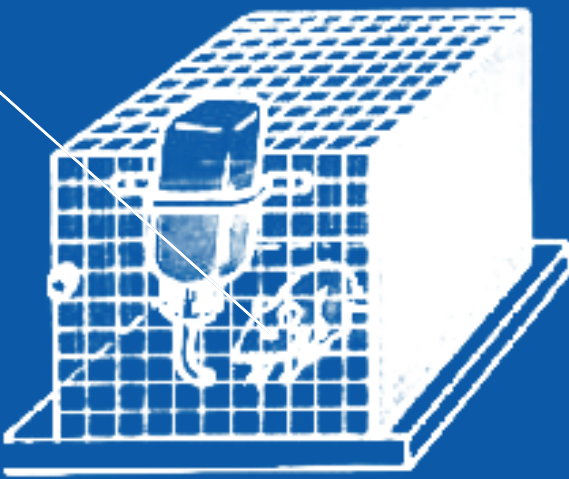

Impoverished

Rat brain cells

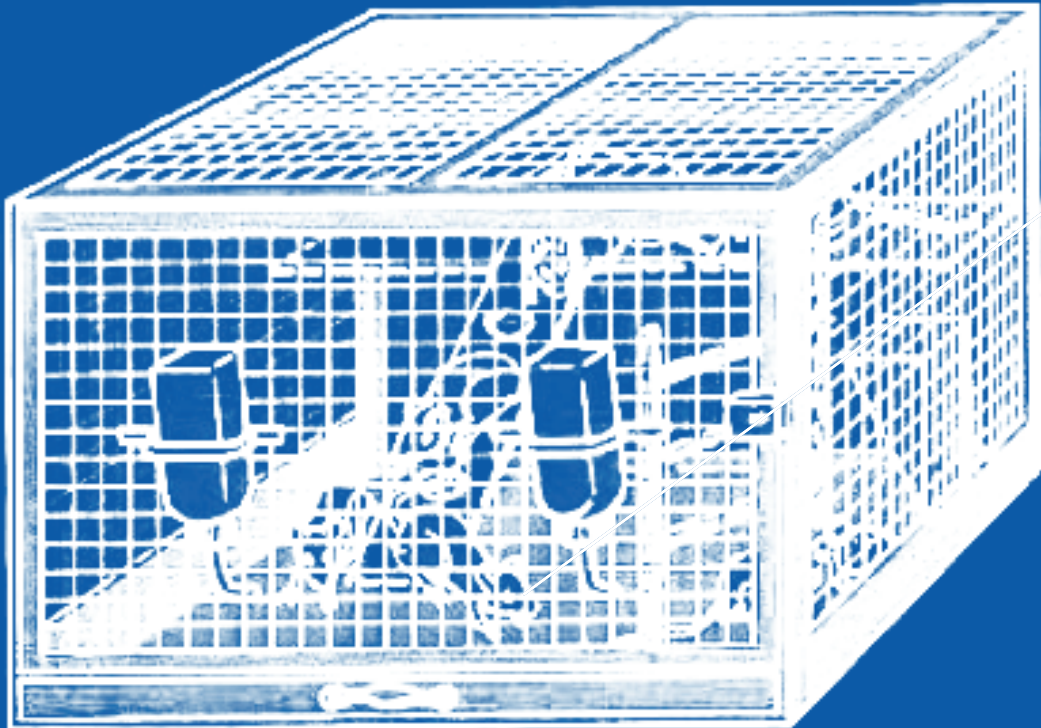

Enriched

Rozenweig and Bennett
Effects of different environments on the brain, 1972



Aad Kieboom
The Urinal Fly, 1990



Nudging

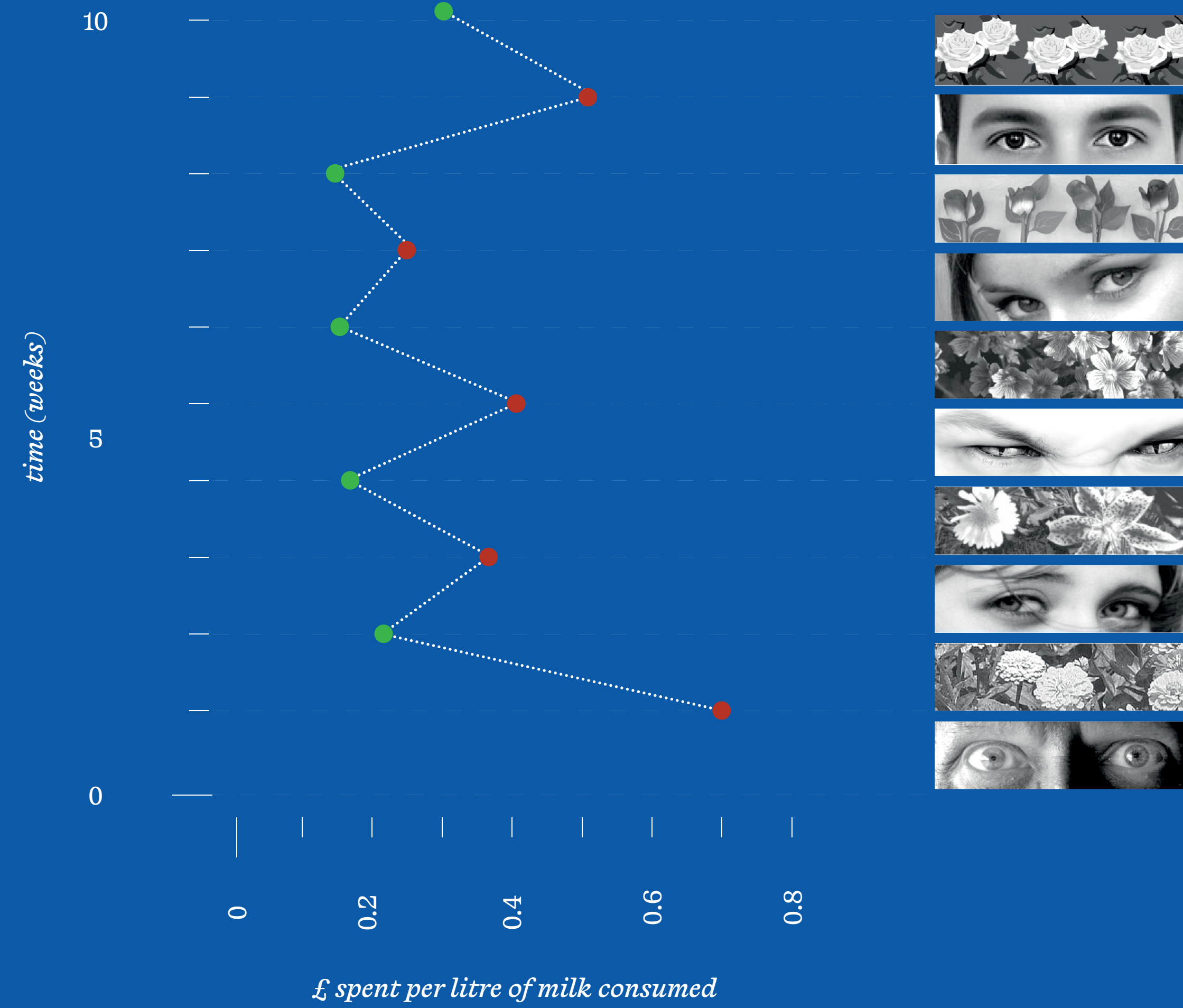

Tools in Neuroarchitecture

Central Nervous System

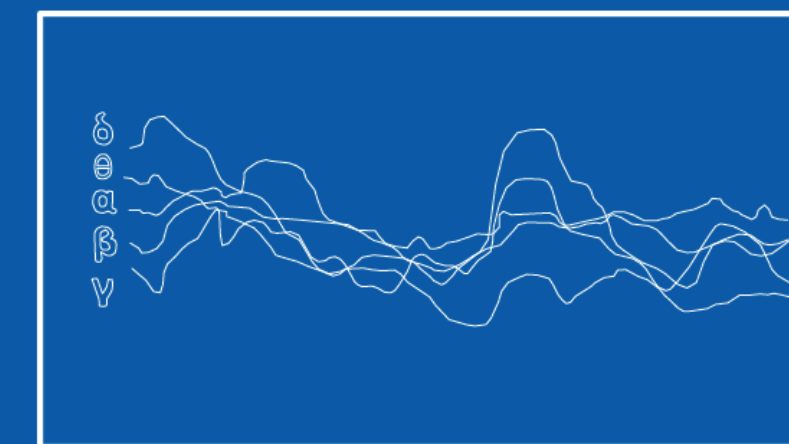
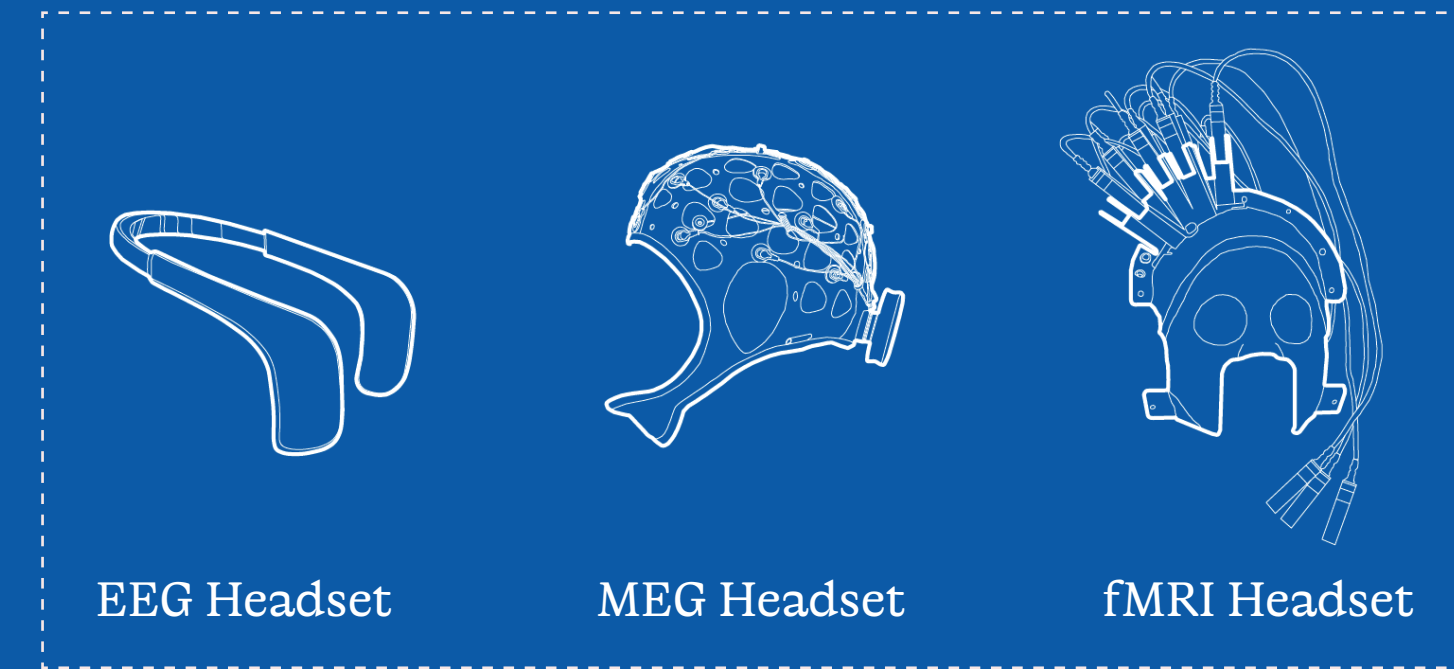
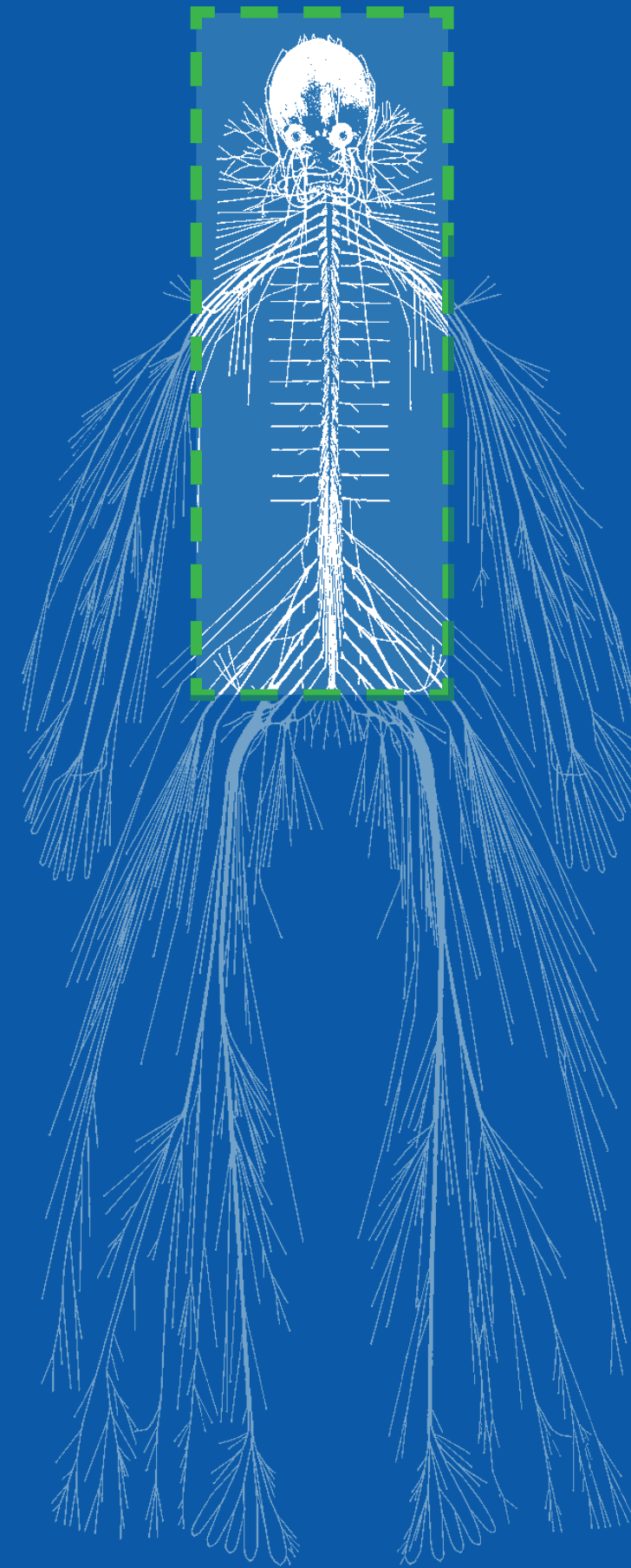

Brain Activity

Dr. Rufus B. Weaver
Nervous system Harriet Cole, 1880

Tools in Neuroarchitecture

Peripheral Nervous System

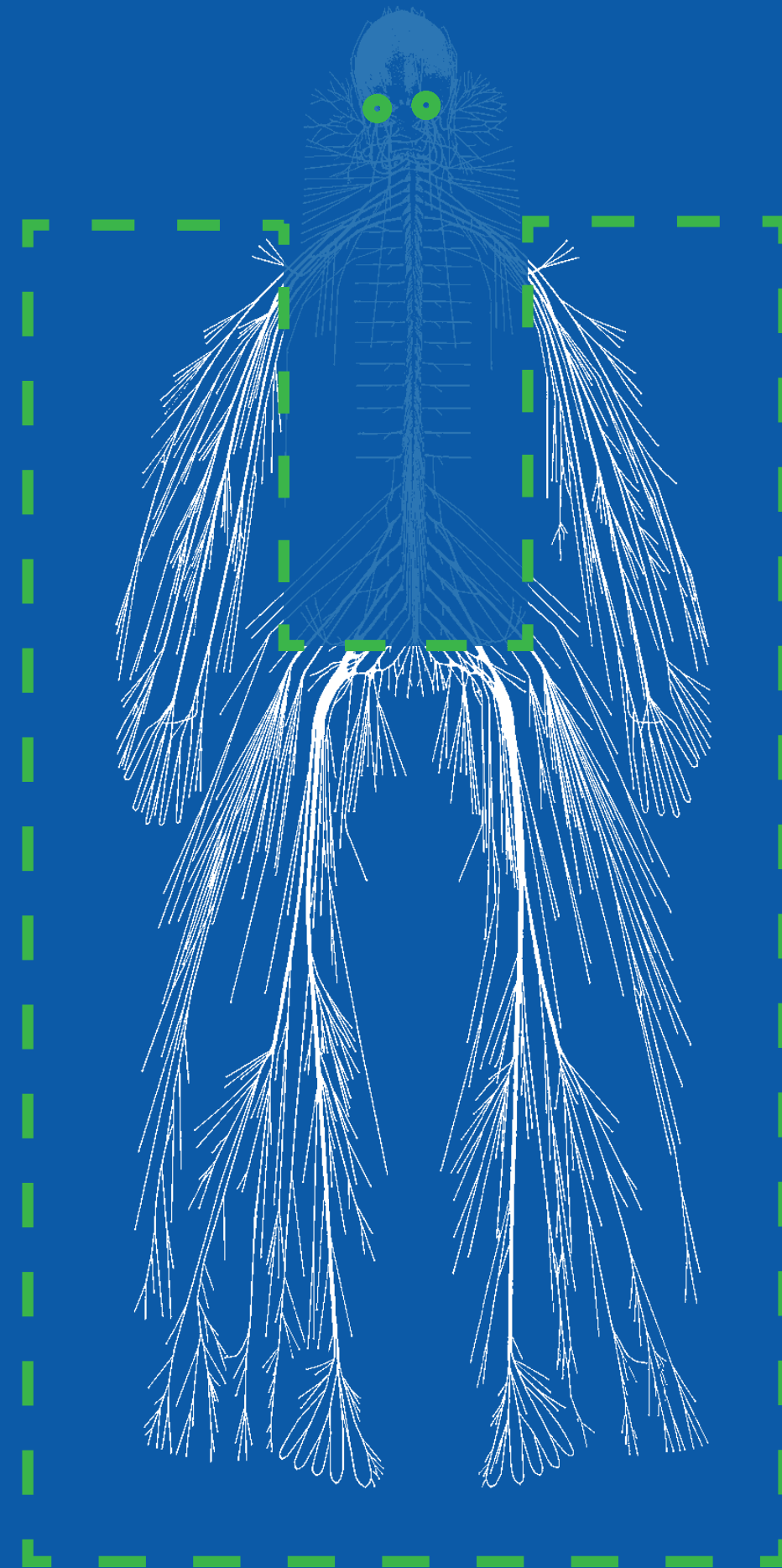

Dr. Rufus B. Weaver
Nervous system Harriet Cole, 1880

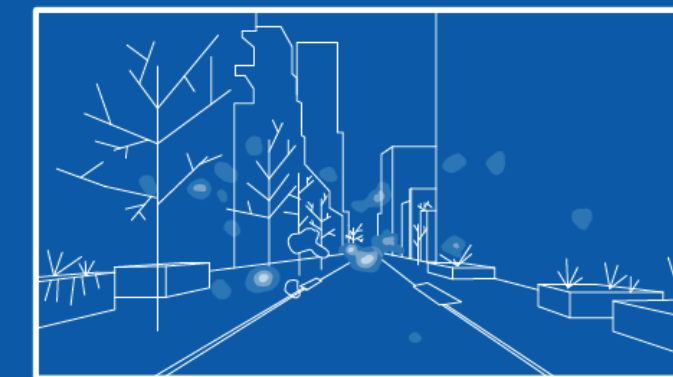
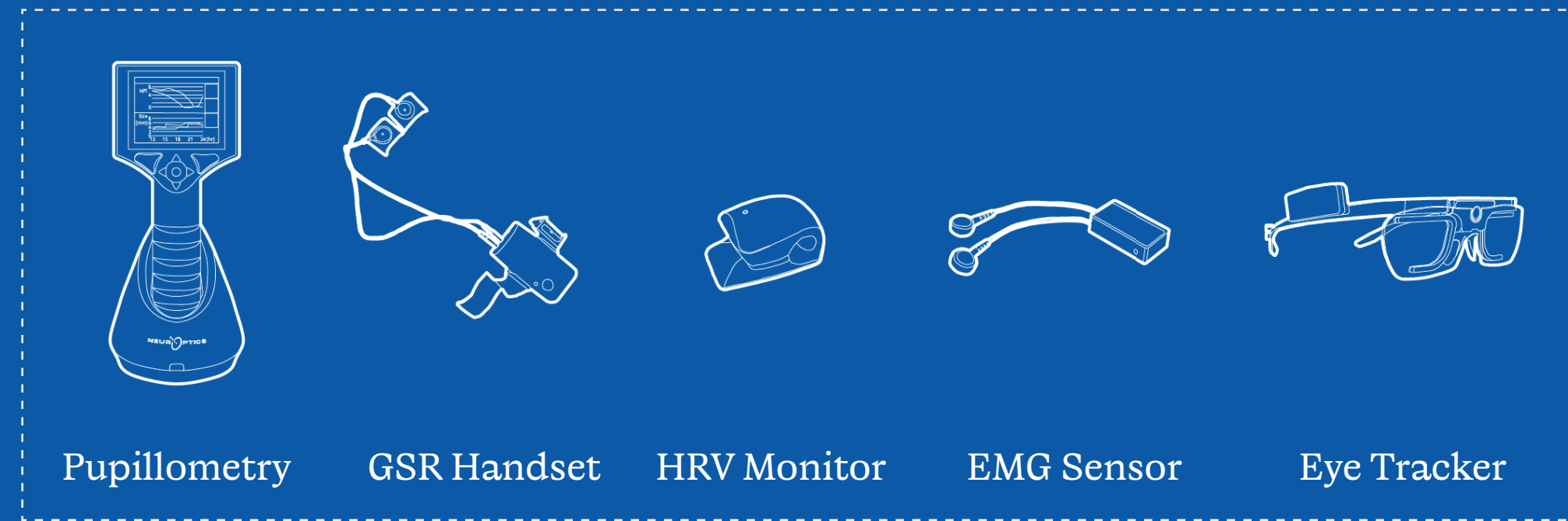

Eye Tracking Results

Tools in Neuroarchitecture

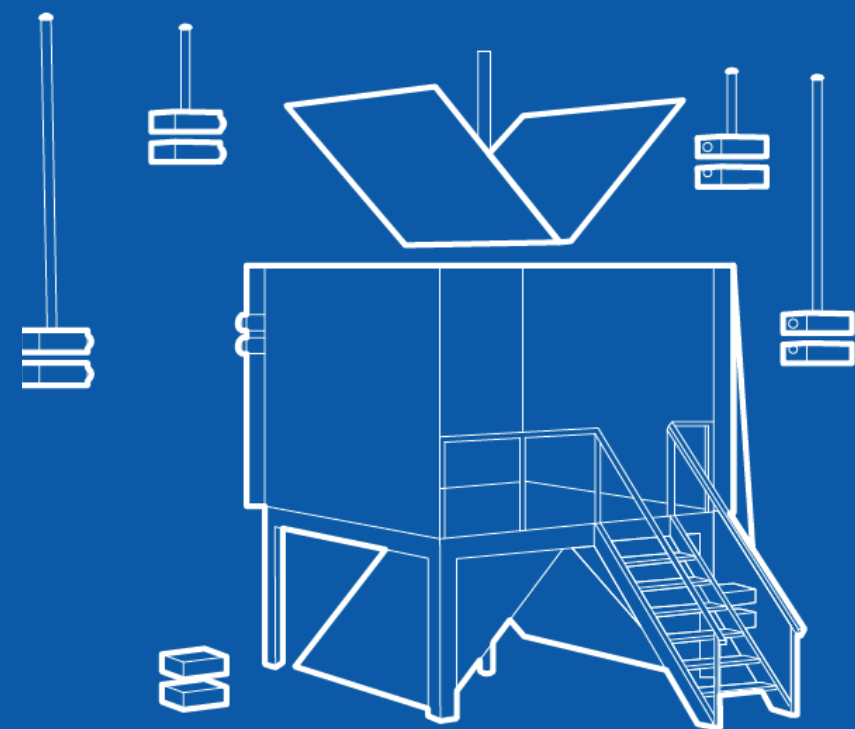

CAVE



VR Device



AR Device



Computer

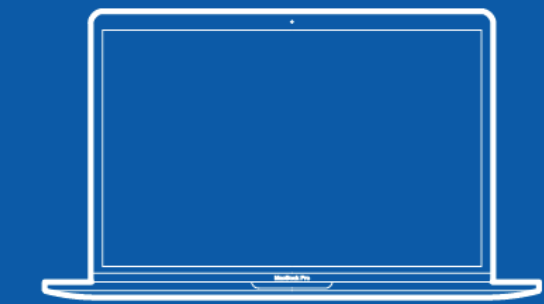

Laptop